

JACK

快速服务 100%

C7 电动超高速包缝机

Super high speed overlock sewing machine

零件手册

Parts Manual

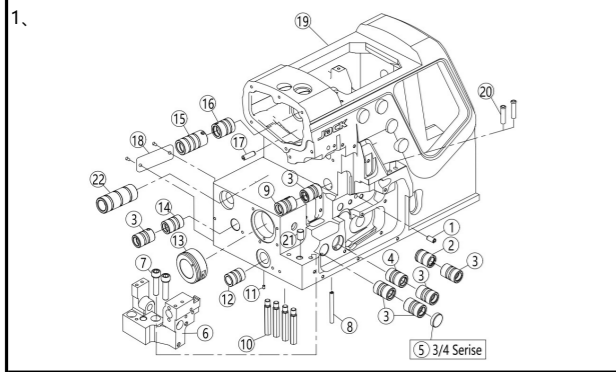

一、机壳部件/Machine Bed Frame

Table with 5 columns: Part No., Part Name, Description, and Quantity (Three, Four, Five thread). Lists parts like pins, sleeves, screws, and the machine bed complete.

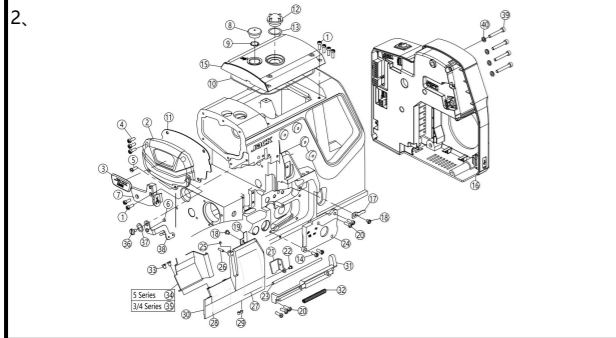

二、机壳罩部件(1)/Cover(1)

Table with 5 columns: Part No., Part Name, Description, and Quantity (Three, Four, Five thread). Lists parts like screws, side covers, machine model plates, and trimmer switch sensors.

Table with 5 columns: Part No., Part Name, Description, and Quantity (Three, Four, Five thread). Lists parts like pins, side covers, screws, and various washers.

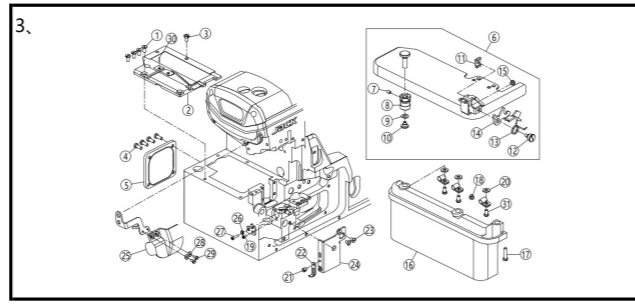

三、机壳罩部件(2)/Cover(2)

Table with 5 columns: Part No., Part Name, Description, and Quantity (Three, Four, Five thread). Lists parts like screws, cover plate assemblies, cloth plates, and various washers.

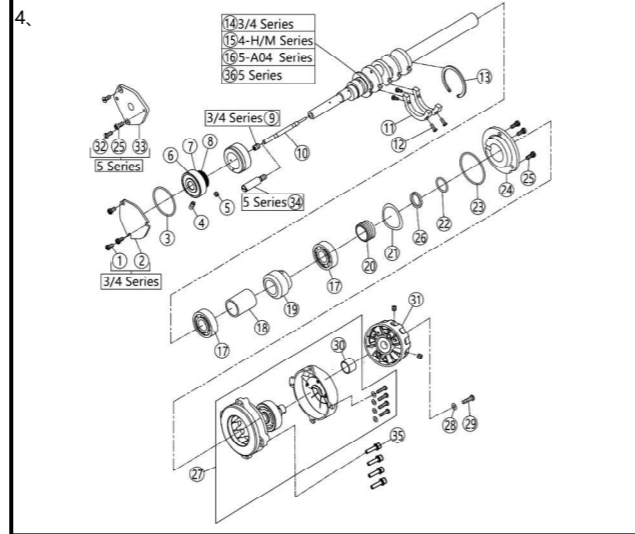

四、主轴部件/Crankshaft Drive Mechanism

Table with 5 columns: Part No., Part Name, Description, and Quantity (Three, Four, Five thread). Lists parts like screws, covers, O-rings, ball bearings, and the crankshaft.

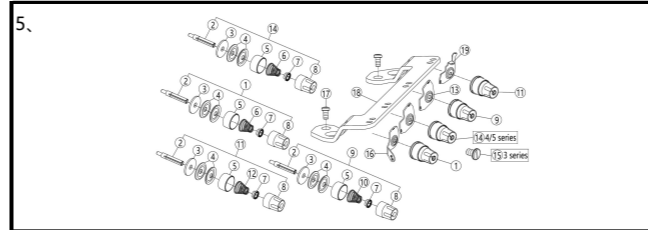

五、夹线部件/Thread Tension Mechanism

Table with 5 columns: Part No., Part Name, Description, and Quantity (Three, Four, Five thread). Lists parts like tension spring assemblies, felt, tension discs, and various fasteners.

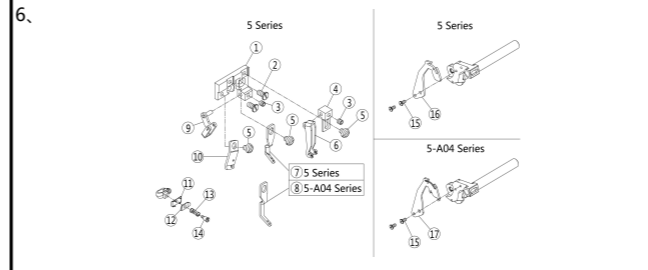

六、过线机构(1)/Thread Guide and Thread Takeup(1)

Table with 5 columns: Part No., Part Name, Description, and Quantity (Three, Four, Five thread). Lists parts like brackets and thread guides.

Table with 5 columns: Part No., Part Name, Description, and Quantity (Three, Four, Five thread). Lists parts like screws, brackets, thread guides, and thread takeups.

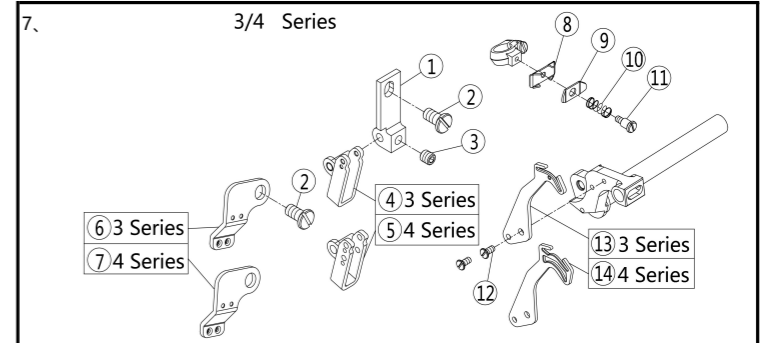

七、过线机构(2)/Thread Guide and Thread Takeup(2)

Table with 5 columns: Part No., Part Name, Description, and Quantity (Three, Four, Five thread). Lists parts like brackets, screws, thread guides, and thread takeups.

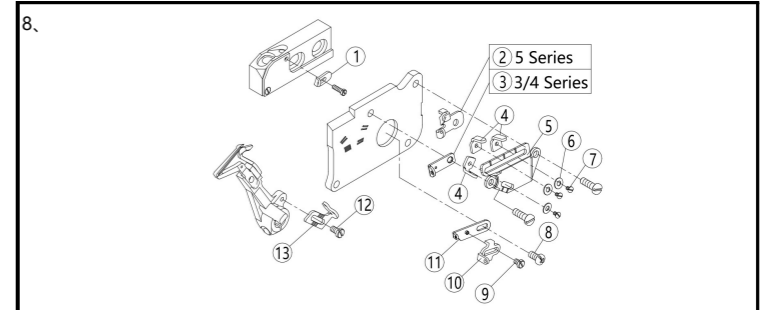

八、过线机构(3)/Thread Guide and Thread Takeup(3)

Table with 5 columns: Part No., Part Name, Description, and Quantity (Three, Four, Five thread). Lists parts like thread guides, thread takeups, and various fasteners.





