

INSTRUCTIONS

INDUSTRIAL LITHIUM ROUNDKNIFE CUTTING MACHINE

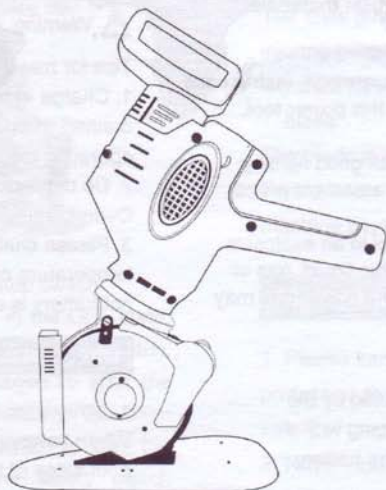

CB-100

Technical data

Model	CB-100
No-load speed	800r/min
Blade diameter	100mm
Cutting thickness	≤35mm
Rated voltage	DC 10. 8V
Charger input voltage	AC 110-240v 50-60Hz
Standard battery pack(capacity)	5000 mAh
Net weight	1750g

The manufacturer reserves the right to change the specifications without prior notice.

Specifications and battery packs may vary by country.

Weight varies depending on accessories (including battery pack).

Main Application

The cutting machine is suitable for cutting flexible soft materials up to 35mm thick, such as leather, carpet, cloth, cardboard and similar materials.

Safety Warning

Please read through all safety warnings, instructions and Specifications attached to this power tool.

Work area safety matters:

1. Keep the work area clean with good lighting condition. Chaotic or dark work areas are prone to unexpected situations.
2. Do not operate the power tool in an explosive environment such as a flammable liquid, gas or dust. The spark generated by the power tool may ignite dust or gas.

Use and maintenance

1. Please use the charger specified by the Manufacturer for charging. Charging with a charger that is not suitable for the battery may cause a fire.
2. Only special batteries can be used for power tools. Using other types of batteries may result in personal injury or fire.
3. Keep it away from small metal objects when not using the battery. These objects may short out the battery terminals and cause a fire.
4. Do not use damaged or modified batteries or tools.
5. Damaged or modified batteries can present unpredictable results, such as fire and explosion.
6. Please follow all charging instructions.

Battery Precautions

1. Please read through all instructions carefully before using the battery.
 2. Do not disassemble the battery.
 3. If the electrolyte gets into your eyes, rinse with clean water and seek medical attention immediately, otherwise your vision may be impaired.
 4. Do not short the battery: Do not allow any conductive material to touch the terminals; Do not place the battery in the same container as other metal objects; Do not place the battery in water or rain.
 5. Do not place tools and batteries in high temperature places.
 6. Do not incinerate or hit the battery.
 7. Do not use a damaged battery.
 8. The lithium ion battery included with this tool meets the requirements of dangerous goods.
 9. Please follow local regulations on how to dispose of used batteries. Dispose of used batteries.
- ⚠ Warning:** Please use original battery.

Tips for maintaining maximum battery life

1. Charge in time before the battery is completely drained. When the tool is in low power, stop operating the tool and charge the battery.
2. Do not recharge a fully charged battery. Overcharging will shorten the battery life.
3. Please charge the battery under normal temperature conditions. Please charge after the hot battery is cooled.

Direction for use

1. Lithium ion battery

When removing the battery, press the buttons on both sides of the battery while pulling the battery out of the tool.

Always turn off the power and remove the battery before adjusting or checking the machine functions. When installing the battery, align the battery in the front-rear direction with the groove on the cover, then push it into place until the battery is locked and clicks.

This unit is equipped with a battery protection system. The system automatically cuts off power to extend battery life.

During operation, the tool may stop running when the battery is overheated or the battery power is too low. In this case, the battery should be cooled and charged in time.

2. sharpen

When using the new machine, first start the machine, and when the blade rotates, press the sharpening button down to sharpen the knife for 10 seconds to make the blade sharper!



3. Fuel filler (oil cup)

Regularly add grease to the turbine from the Fuel filler to increase the service life!



4. Safety switch and start-stop switch

When the safety switch is in the OFF state, do not trigger the start/stop switch, otherwise it may be damaged. To start the unit, first turn the safety switch to ON, then press the start and stop switch to start the machine. Always stop the safety switch when you stop working!

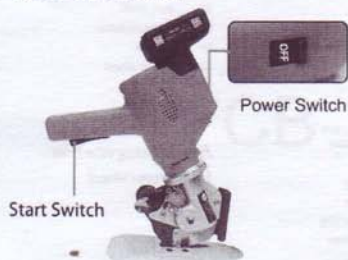

5. Replace the blade

Remove the blade cap and blade with the original special wrench. Tighten the blade cap to secure the blade with a wrench, make sure the surface with words upside to make the blade flat.

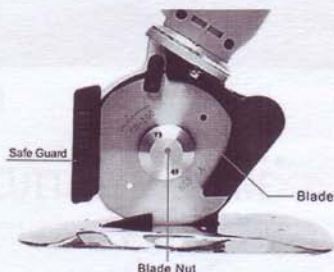

6. blade safe guard

The knife guard prevents the blade from injuring people and the height can be adjusted freely.

7. blade

The blade is sharp, and it is strictly forbidden to touch the blade during machine work!

Maintenance service

1. Please hand over the power tool to a professional service person to ensure the safety of the tool.
2. Never repair a damaged battery pack.
3. Lubricate and replace accessories as instructed.
4. Keep the handle dry, clean, free of oil.
5. Wear gloves when replacing the blade.
6. Always turn off the power or remove the battery before making any adjustments, replacing accessories, or storing power tools.

BREAKDOWN DRAWING

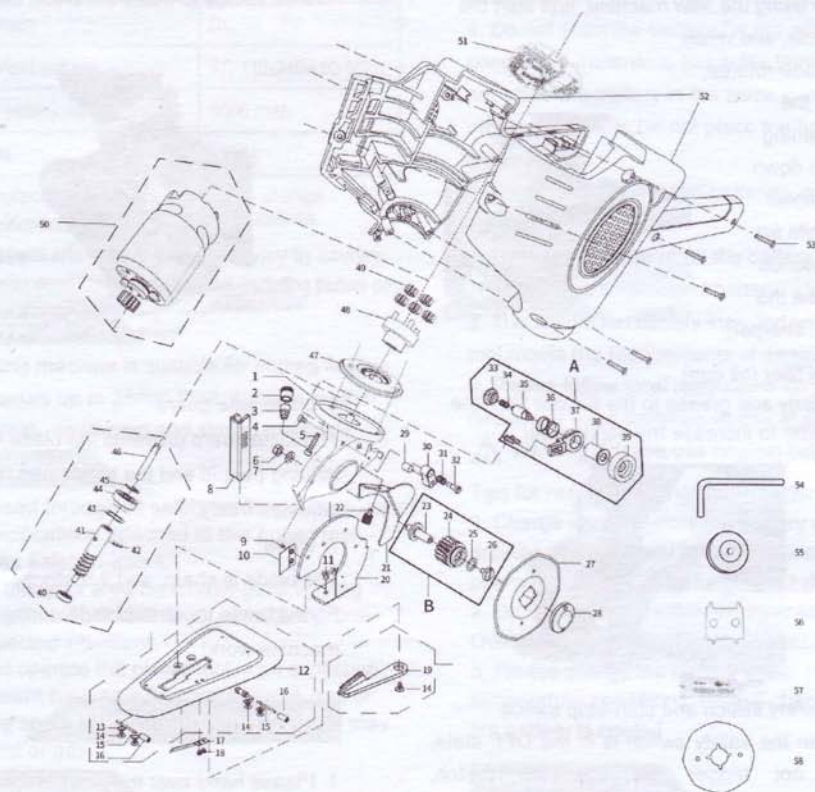

Ref.no.	Description	Ref.no.	Description	Ref.no.	Description	Ref.no.	Description
1	Gear Housing	17	Pressure Spring ROR Lower Blade	33	Grinder Button	49	Planetary Tooth
2	Cap For Guard	18	Standard Screw	34	Spring	50	Motor
3	Grease Cup	19	Lower Knife	35	Grinder Shaft	51	Line Protection Board
4	Standard Screw	20	Standard Screw	36	Spring	52	Body Shell
5	Standard Screw	21	Safety Plate	37	Grinder Wheel Shaft	53	Standard Screw
6	Nut	22	Safety For Plate	38	Grinder Wheel Shaft	54	Spanner
7	Washer	23	Worm Wheel Shaft	39	Grinder Wheel	55	Grinder Wheel
8	Safe Gu	24	Worm Wheel	40	Bearing	56	Spanner
9	Standard Screw	25	Washer	41	Drive Gear	57	Grease Oil
10	Guide Plate	26	Screw	42	Roll Pin	58	Blade
11	Standard Screw	27	Blade	43	Wave Washer		
12	Base plate	28	Blade Nut	44	Bearing	A	Grinding Wheel set
13	Washer	29	Oil Felt	45	Shaft Ring	B	Worm Wheel
14	Standard Screw	30	Knife Oiler	46	Drive Gear		
15	Roller Shaft (Front)	31	Spring For Olier	47	Outer Gear ring		
16	Front Roller	32	Screw For Olier	48	Planet Carrier		