

Yamato[®]

Parts List

HIGH SPEED TOP FEEDING
CYLINDER BED INTERLOCK STITCH MACHINE

VES2700-8

MODELS

VES2713-2-8F
VES2711-1-8

VES2711-1-8F



YAMATO SEWING MACHINE MFG. CO., LTD.

パーツリストの見方

このパーツリストはVES2713-156S-2-K4N-8Fを基本モデルにしてイラストを作成しています。

パーツリストに記載されているカラーの寸法は内径×外径×幅を表わしています。

記号の説明 (Parts No. の隣に記載されています。)

[] 前回のパーツリストに対して、今回変更された部品を表わしています。

[] 内は旧Parts No. 及びネジ類の形状

◆ 前回のパーツリストに対して、今回追加された部品及びモデルを表わしています。

部品注文の際のご注意

☆ このパーツリストに記載されている部品をご注文の際は、Parts No.(例えば、3500201)でお願いします。

☆ 0068011の場合は、0068011又は68011でご注文下さい。

☆ エアチューブ御注文の際は品番と長さをお知らせ下さい。

なお、このパーツリストの記載事項は、改良により変更される場合がありますのでご了承下さい。

How to use this Parts List

The illustrations on this Parts List are drawn on the basis of VES2713-156S-2-K4N-8F.

The dimension of Collar on this Parts List shows Inside diameter X Outside diameter X Width.

Explanation of Marks (marked at the Side of Part No.)

[] means this part is changed from the previous Parts List.

Inside of [] shows the previous Part No. and the shape of screw or the like.

◆ means this part and model is added to the previous Parts List.

How to place an order for the parts

☆ When placing an order for the parts from this Parts List, please clearly state the Parts No. (e.g.3500201) which you require so that we can deliver the correct Parts to you.

☆ When the Part No. is "0068011", please place an order for the part by showing "0068011" or "68011".

☆ When ordering Air Tube, please inform us of the Part No. and the length.

This Parts List is subject to change without notice.

Contents

目次

MISCELLANEOUS COVERS(1)	カバー関係 (1)	1
MISCELLANEOUS COVERS(2)	カバー関係 (2)	2
MISCELLANEOUS COVERS(3)	カバー関係 (3)	3
MISCELLANEOUS THREAD EYELETS	糸道関係	4
MISCELLANEOUS BUSHINGS	ブッシュ関係	5
NEEDLE GUARD & MAIN SHAFT DRIVING MECHANISM	針受ケ及び下軸機構	6
MISCELLANEOUS LOOPER THREAD TAKE-UP	下糸調子カム関係	7
UPPER SHAFT & NEEDLE THREAD TAKE-UP MECHANISM	上軸及び針糸繰り機構	8
NEEDLE BAR MECHANISM	針棒機構	9
PRESSER FOOT MECHANISM	押エ機構	10
TOP FEED VERTICAL MECHANISM	上送り上下機構	11
TOP FEED ROCKER MECHANISM	上送り前後機構	12
TOP FEED DIFFERENTIAL MECHANISM	上送り差動機構	13
SPREADER MECHANISM	飾り糸ルーパ機構	14
LOOPER DRIVING MECHANISM	ルーパ機構	15
FEED DRIVING CONTROL MECHANISM	送り調節機構	16
FEED DRIVING MECHANISM(1)	送り機構(1)	17
FEED DRIVING MECHANISM(2)	送り機構(2)	18
LUBRICATING MECHANISM(1)	給油機構(1)	19
LUBRICATING MECHANISM(2)	給油機構(2)	20
VES2711-156S-1-8F EXCLUSIVE PARTS	サブモデル専用部品	21
VES2711-156S8-1-8 EXCLUSIVE PARTS	サブモデル専用部品	22
VES2713-156L-2-T1N-8F EXCLUSIVE PARTS	サブモデル専用部品	23
THREAD STAND	糸立台	24
WARNING LABEL	警告ラベル	25
INDEX	索引	26

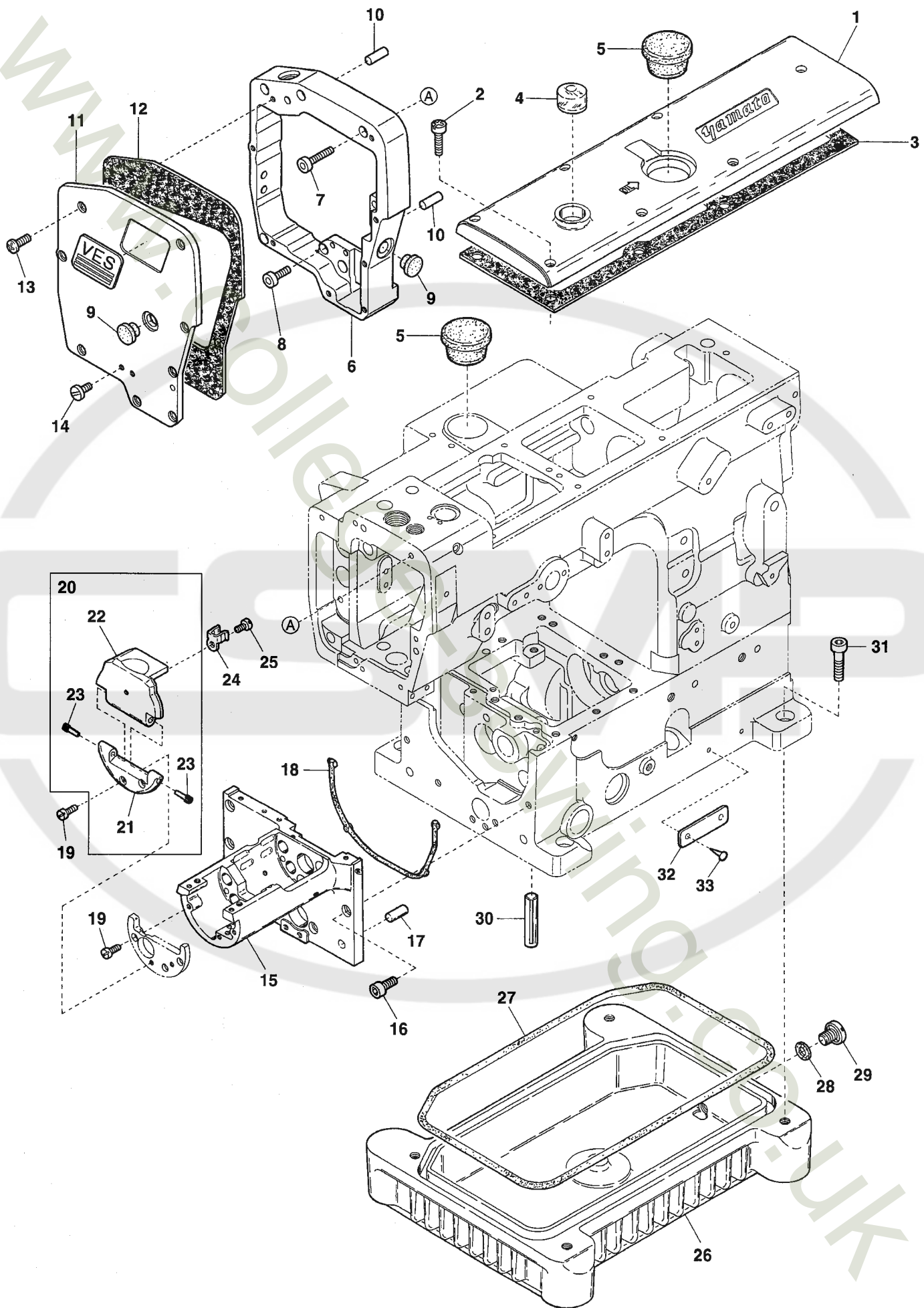

Ref.No	Parts No.	Description	品名	Amt. Req
1	3500201	Top Cover	上カバー	1
2	110045	Screw(M4-0.7 × 12)	止ネジ	7
3	3500430	Top Cover Gasket	上カバーパッキン	1
4	0068011	Oil Sight Window	オイル確認窓	1
5	0020759	Top Cover Seal Plug	上カバー詰栓	2
6	3510008	Top Feed Dog Bracket	上送り台ブラケット	1
7	120027	Screw(M4-0.7 × 25)	止ネジ	4
8	009748	Screw(M4-0.7 × 12)	止ネジ	2
9	0093864	Seal Plug	詰栓	2
10	3100207	Pin(5 × 12mm)	ピン	2
11	3510011	Head Cover	ヘッドカバー	1
12	3510012	Head Cover Gasket	ヘッドカバーパッキン	1
13	110048	Screw(M4-0.7 × 10)	止ネジ	8
14	110060	Screw(M4-0.7 × 4.8)	止ネジ	2
15	3150004	Cylinder	シリンダ	1
16	009752	Screw(M5-0.8 × 15)	止ネジ	5
17	3150163	Knock Pin	ノックピン	2
18	3150141	Cylinder Gasket	シリンダパッキン	1
19	110036	Screw(M3-0.5 × 6.5)	止ネジ	5
20	3150099	Side Cover, Complete Set	横開キカバー(組)	1
21	3150100	Side Cover Hinge	横開キカバーヒンジ	1
22	3150101	Side Cover	横開キカバー	1
23	340034	Side Cover Hinge Pin	横開キカバーヒンジピン	2
24	3150119	Cover Latch Spring	カバーラッチバネ	1
25	009995	Screw(M3-0.5 × 5)	止ネジ	1
26	3100004	Oil Reservoir	油受ケ	1
27	3100005	Oil Reservoir Gasket	油受ケパッキン	1
28	0020137	Drain Hole Seal	油抜キネジパッキン	1
29	005075	Screw(3/8-24 × 8)	油抜キネジ	1
30	340000	Machine Frame Supporting Bar	ベッド支工棒	4
31	120016	Screw(M8-1.25 × 20)	止ネジ	4
32	2049401	Serial Number Plate	機番プレート	1
33	000726	Rivet	止メ鋸	2

Ref.No	Parts No.	Description	品名	Amt. Req
1	3150103	Cloth Plate(Large)	クロスプレート(大)	1
2	009748	Screw(M4-0.7 × 12)	止ネジ	3
3	3100020	Crank Chamber Cover	ナカカバー	1
4	3180035	Crank Chamber Cover Gasket	ナカカバーパッキン	1
5	130003	Screw(M4-0.7 × 7.3)	止ネジ	10
6	3150105	Machine Frame Upper Cover(Left)	ベッド上カバー(左)	1
7	009779	Screw(M3-0.5 × 6)	止ネジ	7
8	3150102	Cylinder Cover(Rear)	シリンダカバー(後)	1
9	009744	Screw(M3-0.5 × 10)	止ネジ	2
10	0093864	Seal Plug	詰栓	3
11	3150129	Rubber Plate	ゴムプレート	1
12	3150106	Upper Cover Support	ベッド上カバー取付板	1
13	3160008	Bracket Cover	ブラケットカバー	1
14	3160009	Bracket Cover Gasket	ブラケットカバーパッキン	1
15	110045	Screw(M4-0.7 × 12)	止ネジ	4
16	3500012	Seal Plug	詰栓	1
17				
18	0065275	Seal Plug	詰栓	1
19	0020052	Seal Plug	詰栓	1
20	3100113	Needle Bar Guard	針棒ガード	1
21	110079	Screw(M4-0.7 × 8)	止ネジ	2
22	3150095	Cylinder Upper Cover	シリンダ上カバー	1
23	3150097	Cylinder Upper Cover Spring(Rear)	シリンダ上カバーバネ(後)	1
24	110091	Screw(M3-0.5 × 3)	止ネジ	4
25	3150096	Cylinder Upper Cover Spring(Front)	シリンダ上カバーバネ(前)	1
26	3150181	Stitch Plate Support	針板取付板	1
27	110041	Screw(M4-0.7 × 8)	止ネジ	2
28	340036	Knock Pin	ノックピン	2
29	340035	Knock Pin	ノックピン	1
30	110032	Screw(M3-0.5 × 6.5)	止ネジ	2
31	3150123	Positioning Bushing	位置決メブッシュ	2

3

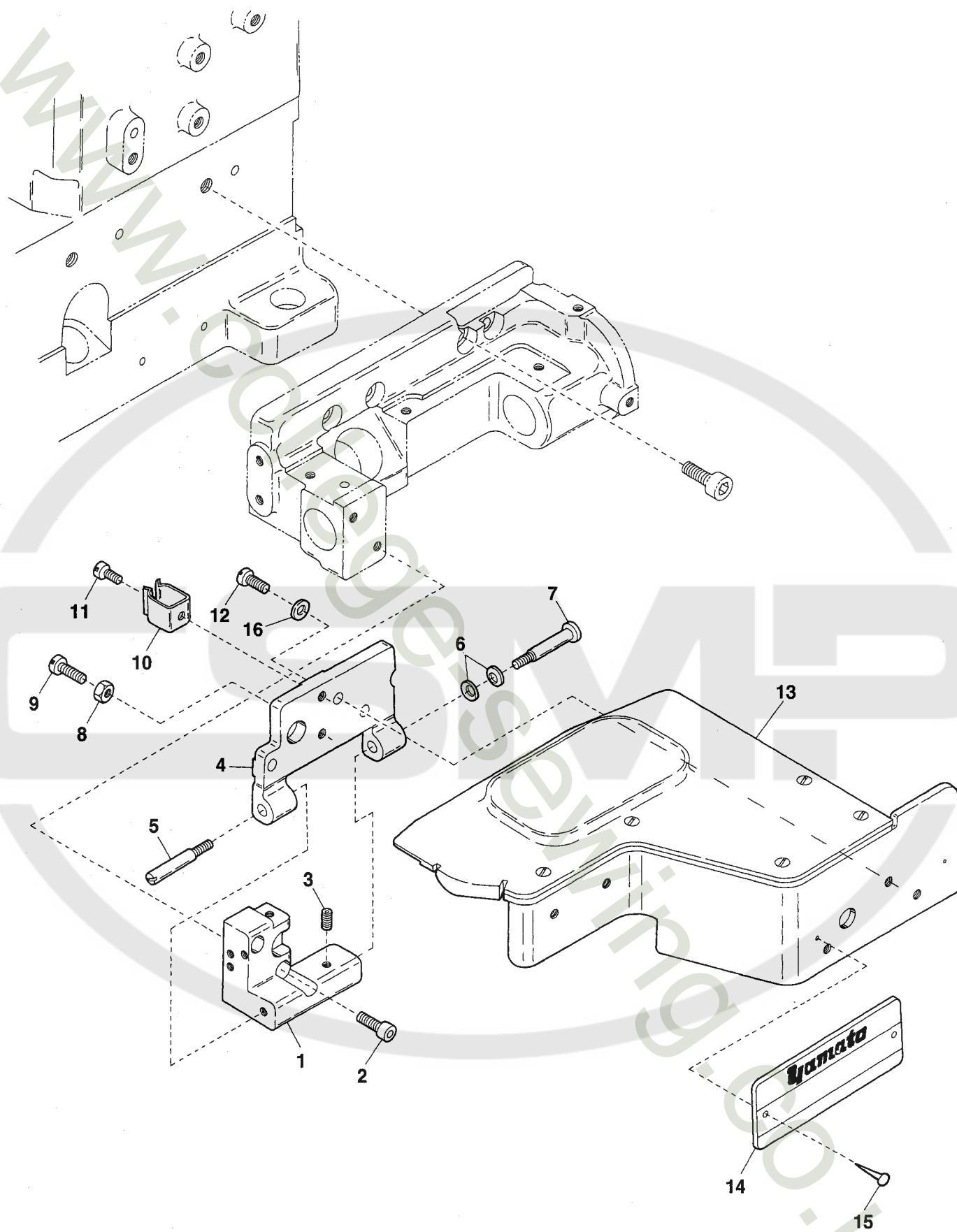

Ref.No	Parts No.	Description	品名	Amt. Req
1	3150116	Front Cover Hinge Bracket	前開キカバーヒンジ取付台	1
2	120001	Screw(M4-0.7 × 94)	止ネジ	2
3	160001	Screw(M4-0.7 × 4)	止ネジ	1
4	3150114	Front Cover Support	前開キカバー取付板	1
5	180005	Screw(M5-0.8 × 6)	止ネジ	1
6	300100	Conical Spring Washer	皿バネワッシャ	2
7	170001	Screw(M4-0.7 × 8)	止ネジ	1
8	000022	Nut	ナット	1
9	110035	Screw(M4-0.8 × 10)	止ネジ	1
10	0094201	Cover Latch Spring	カバーラッチバネ	1
11	110012	Screw(M4-0.7 × 5)	止ネジ	1
12	110048	Screw(M4-0.7 × 10)	止ネジ	3
13	3150111	Front Cover Unit	前開キカバー(組)	1
14	4109403	Model Plate(See the below)	型式板(下記参照)	1
15	000726	Rivet	止メ鋸	2
16	000538	Washer	ワッシャ	3

Note : Order for Model Plate must be accompanied by model designation(including symbols of gauge and devices).

(注) 型式板を御注文の際は機種名(ゲージ記号、附帯装置含む)をお知らせください。

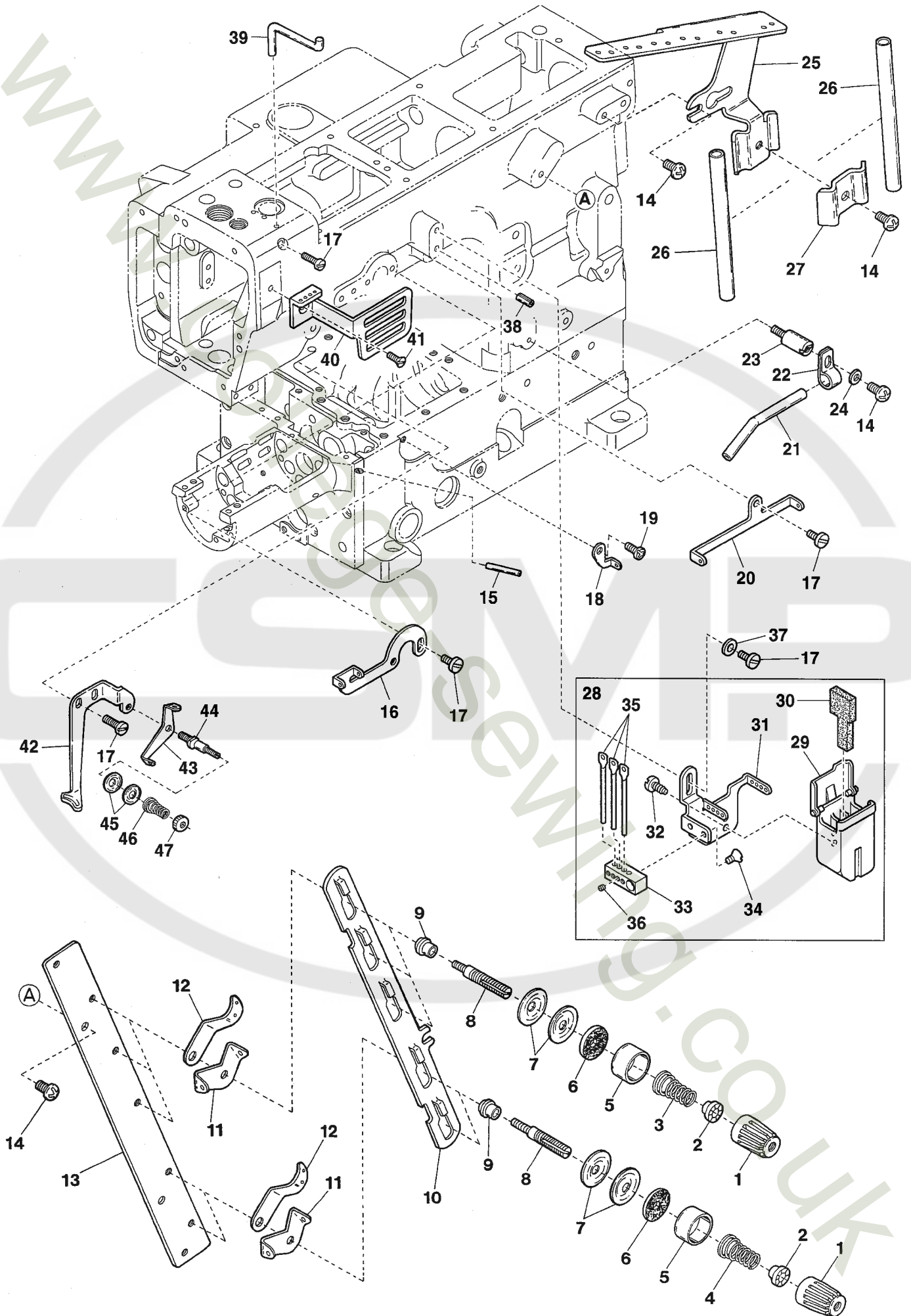

Ref.No	Parts No.	Description	品名	Amt. Req
1	0024084	Thread Tension Spring Cap	糸調子バネキャップ(上)	5
2	0024083	Tension Spring Bushing	糸調子ナット回り止メ	5
3	0030255	Tension Spring(Needle)	糸調子バネ(針糸)	3
4	0032952	Tension Spring(Looper, Top Cover)	糸調子バネ(ルーバ、飾り)	2
5	0090071	Thread Tension Spring Retainer	糸調子バネキャップ(下)	5
6	000177	Felt	フェルト	5
7	0031111	Tension Disc	糸調子皿	10
8	290029	Tension Post	糸調子棒	5
9	0090812	Tension Post Ferrule	糸調子棒糸摺レ	5
10	3500287	Tension Disc Separator	糸緩メ板	1
11	0090856	Tension Disc Eyelet	糸調子皿糸道	5
12	0090807	Thread Lead-in Guide	糸調子台糸道	5
13	3500286	Tension Post Support	糸調子台	1
14	110013	Screw(M4-0.7 × 8)	止ネジ	6
15	3150109	Thread Eyelet Pipe	糸道パイプ	1
16	3180076	Top Cover Thread Eyelet(Left)	飾り糸道(左)	1
17	110009	Screw(M4-0.7 × 8)	止ネジ	7
18	0080393	Thread Eyelet(Front)	前糸道	1
19	110012	Screw(M4-0.7 × 5)	止ネジ	1
20	3500489	Top Cover Thread Eyelet(Right)	飾り糸道(右)	1
21	0021735	Thread Eyelet Pipe(Long)	糸道パイプ(長)	1
22	0093528	Thread Eyelet Pipe Stay	糸道パイプ支エ	3
23	190102	Screw(M4-0.7 × 8)	止ネジ	1
24	000538	Washer	ワッシャ	3
25	3500284	Thread Guide Plate	糸案内板	1
26	0020119	Thread Eyelet Pipe(Short)	糸道パイプ(短)	2
27	3500285	Thread Eyelet Pipe Holder	糸道パイプ押エ	1
28	3180071	SP Device, Complete Set	SP装置(組)	1
29	3100384	SP Container	SPタンク	1
30	3100386	Felt	SPフェルト	1
31	3180072	Needle Thread Eyelet	針糸道	1
32	350009	Tapping Screw(3 × 6mm)	タッピンネジ	2
33	0068247	Needle Thread Eyelet Holder	針糸道台	1
34	005431	Screw(1/8-44 × 4.4)	止ネジ	2
35	0068249	Needle Thread Eyelet	針糸道	3
36	003312	Screw(1/8-44 × 3.4)	止ネジ	3
37	000538	Washer	ワッシャ	1
38	000651	Guide Pin	ガイドピン	1
39	0090068	Needle Thread Guide	針糸受ケ	1
40	3180073	Needle Thread Eyelet	針糸道	1
41	130003	Screw(M4-0.7 × 4.5)	止ネジ	1
42	3100081	Top Cover Thread Guide	飾り糸案内	1
43	0063074	Supplementary Thread Guide	小調子台糸道	1
44	001818	Tension Post	糸調子棒	1
45	0037108	Supplementary Tension Disc	小調子皿	2
46	0035813	Supplementary Tension Spring	飾り糸調子バネ	1
47	000360	Nut	ナット	1

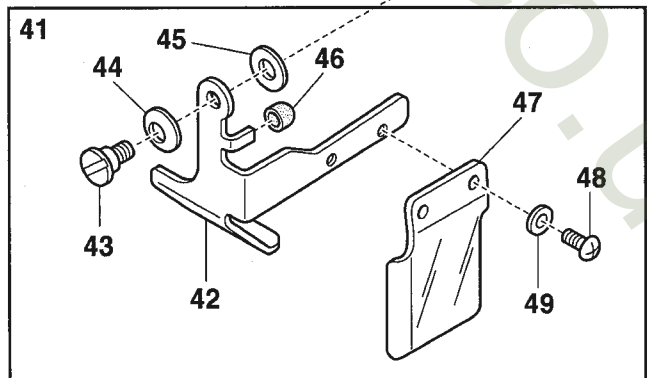
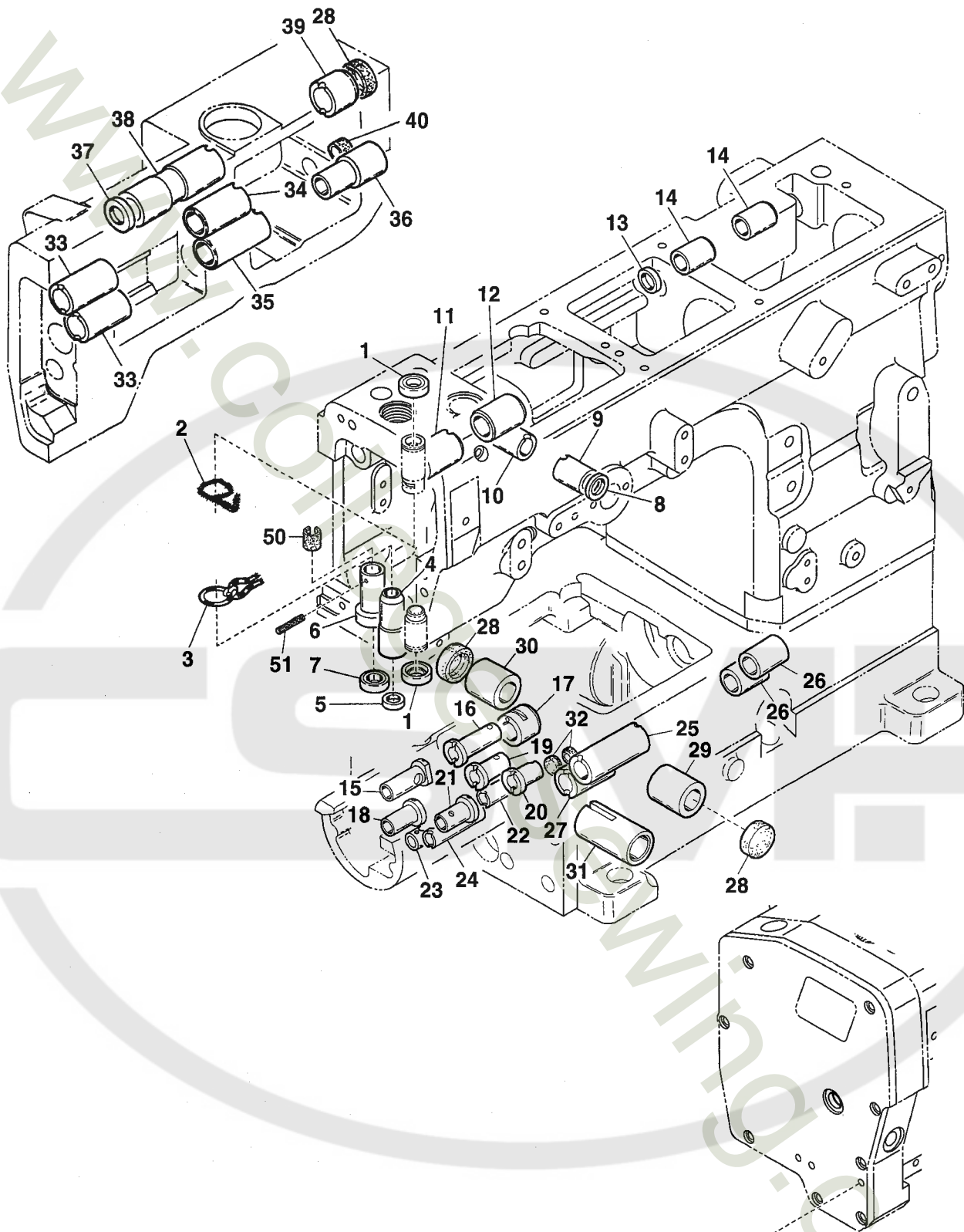

Ref.No	Parts No.	Description	品名	Amt. Req
1	3500309	Oil Seal	オイルシール	2
2	310106	Laced Wire(Φ 3 × 130mm)	モール	1
3	000195	Oil Wick(No. 4-175mm)	油芯	1
4	3160158	Presser Bar Bushing	押工棒ブッシュ	1
5	3204021	Oil Seal	オイルシール	1
6	3100100	Spreader Driving Bar Bushing	飾り糸ルーパ棒ブッシュ	1
7	0063055	Oil Seal	オイルシール	1
8	3500050	Oil Seal	オイルシール	1
9	3500044	Needle Thread Take-up Bushing(Front)	針糸繰り軸ブッシュ(前)	1
10	3500045	Needle Thread Take-up Bushing(Rear)	針糸繰り軸ブッシュ(後)	1
11	3500047	Spreader Driving Shaft Bushing(Left)	飾り糸ルーパ棒ブッシュ(左)	1
12	3500048	Spreader Driving Shaft Bushing(Right)	飾り糸ルーパ棒ブッシュ(右)	1
13	3500041	Oil Seal	オイルシール	1
14	3500046	Foot Lifter Lever Bushing	押工揚ゲ軸ブッシュ	2
15	3150007	Feed Bar Lift Bushing(Rear/Left)	送り上下軸ブッシュ(後)(左)	1
16	3150008	Feed Bar Lift Bushing(Rear/Right)	送り上下軸ブッシュ(後)(右)	1
17	3150019	Lower Shaft Bushing	下軸ブッシュ	1
18	3150013	Feed Rocker Bushing(Left)	送り前後軸ブッシュ(左)	1
19	3150012	Feed Rocker Bushing(Right)	送り前後軸ブッシュ(右)	1
20	3150009	Feed Bar Lift Bushing(Front/Right)	送り上下軸ブッシュ(前)(右)	1
21	3150010	Feed Bar Lift Bushing(Front/Left)	送り上下軸ブッシュ(前)(左)	1
22	3150016	Needle Guard Bushing(Right)	針受ケ軸ブッシュ(右)	1
23	3150014	Needle Guard Bushing(Left)	針受ケ軸ブッシュ(左)	1
24	3150015	Needle Guard(Front) Bushing	針受ケ(前)軸ブッシュ	1
25	3150011	Feed Bar Lift Bushing(Large/Left)	送り上下軸ブッシュ(大)(左)	1
26	3150018	Feed Bar Bushing(Large/Right)	送り軸ブッシュ(大)(右)	2
27	3150017	Feed Rocker Bushing(Large/Left)	前後軸ブッシュ(大)(左)	1
28	3100006	Seal Plug	詰栓	3
29	3100092	Looper Driving Shaft Bushing(Front)	ルーパ軸ブッシュ(前)	1
30	3100093	Looper Driving Shaft Bushing(Rear)	ルーパ軸ブッシュ(後)	1
31	3150020	Adjusting Screw Bushing	送り調節ネジブッシュ	1
32	2100034	Seal Plug	詰栓	2
33	3160022	Top Feed Shaft Bushing	上送り軸ブッシュ	2
34	3160023	Vertical Motion Shaft Bushing(Right)	上送り上下軸ブッシュ(右)	1
35	3160024	Top Feed Rocker Shaft Bushing(Right)	上送り前後軸ブッシュ(右)	1
36	3160027	Adjusting Shaft Bushing	前後調節軸ブッシュ	1
37	0032684	Oil Seal	オイルシール	1
38	3160025	Rocker Drive Shaft Bushing(Left)	前後駆動軸ブッシュ(左)	1
39	3160026	Rocker Drive Shaft Bushing(Right)	前後駆動軸ブッシュ(右)	1
40	0020051	Seal Plug	詰栓	1
41	3510050	Eye Guard, C. Set	アイガード(組)	1
42	3510051	Finger Guard	フィンガガード	1
43	170010	Screw(M4-0.7 × 4)	止ネジ	1
44	300100	Conical Spring Washer	皿バネワッシャ	1
45	000669	Washer	ワッシャ	1
46	3100272	Cushion	クッション	1
47	3510052	Eye Guard	アイガード	1
48	110076	Screw(M3-0.5 × 6)	止ネジ	2
49	000014	Washer	ワッシャ	2
50	3500096	Sponge	給油スポンジ	1
51	000397	Oil Wick (Φ 2 × 11mm)	油芯	1

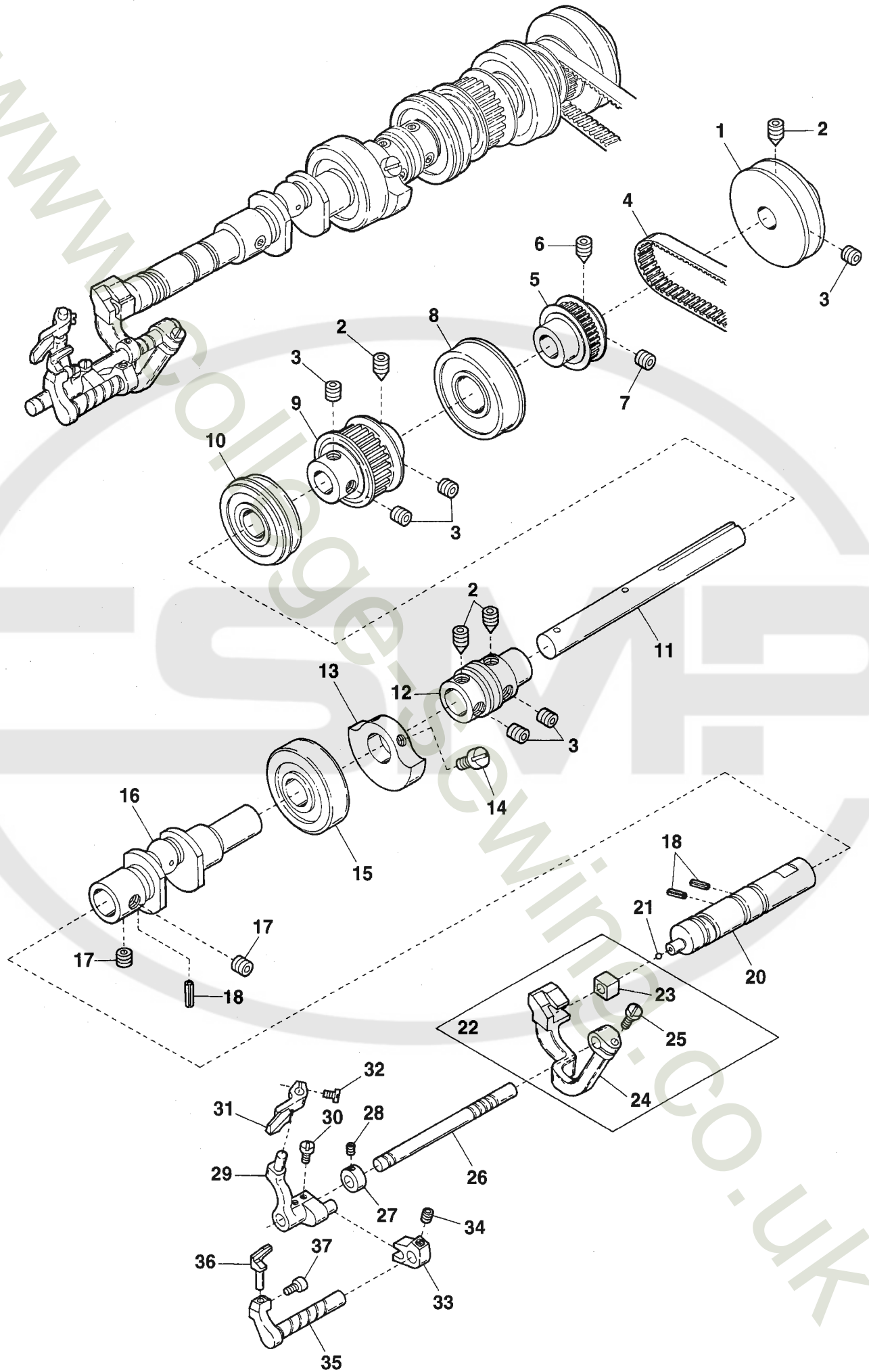

Ref.No	Parts No.	Description	品名	Amt. Req
1	3150074	Pulley	プーリ	1
2	160005	Screw(M6-1 × 8)	止ネジ	4
3	160007	Screw(M6-1 × 6)	止ネジ	6
4	3120070	Timing Belt	タイミングベルト	1
5	3150073	Belt Pulley(Rear)	ベルトプーリ(後)	1
6	160021	Screw(M5-0.8 × 6)	止ネジ	1
7	160009	Screw(M5-0.8 × 5)	止ネジ	1
8	0093089	Ball Bearing(Right)	ボールベアリング(右)	1
9	3260010	Main Shaft Sprocket(Lower)	ベルトプーリ(下)	1
10	3100131	Ball Bearing(Middle)	ボールベアリング(中)	1
11	3150069	Lower Shaft(Right)	下軸(右)	1
12	3100122	Oil Pump Driving Worm	ウオーム	1
13	3100127	Counterweight(Small)	バランスウエイト(小)	1
14	110009	Screw(M4-0.7 × 8)	止ネジ	2
15	3100123	Ball Bearing(Left)	ボールベアリング(左)	1
16	3100121	Lower Crankshaft	下軸クランク	1
17	160004	Screw(M6-1 × 4.8)	止ネジ	2
18	001107	Roll Pin	ロールピン	3
19				
20	3150183	Lower Shaft(Left)	下軸(左)	1
21	000636	Seal Plug	詰栓	1
22	3150080	Needle Guard Arm Block, C. Set	針受ケ腕角駒(組)	1
23	3150072	Needle Guard Arm Block	針受ケ腕角駒	1
24	3150081	Needle Guard Arm	針受ケ腕	1
25	110035	Screw(M4-0.7 × 10)	止ネジ	1
26	3150082	Needle Guard Driving Shaft	針受ケ軸	1
27	3150083	Collar(6 × 11 × 5mm)	カラー	1
28	160000	Screw(M3-0.5 × 3)	止ネジ	1
29	3150089	Needle Guard(Rear) Holder	針受ケ(後)台	1
30	110060	Screw(M4-0.7 × 5)	止ネジ	2
31	3159201	Needle Guard(Rear)	針受ケ(後)	1
32	110036	Screw(M3-0.5 × 6.5)	止ネジ	1
33	3150086	Needle Guard(Front) Arm	針受ケ(前)腕	1
34	160001	Screw(M4-0.7 × 4)	止ネジ	1
35	3150088	Needle Guard(Front) Holder	針受ケ(前)台	1
36	3159200	Needle Guard(Front)	針受ケ(前)	1
37	120048	Screw(M3-0.5 × 3.5)	止ネジ	1

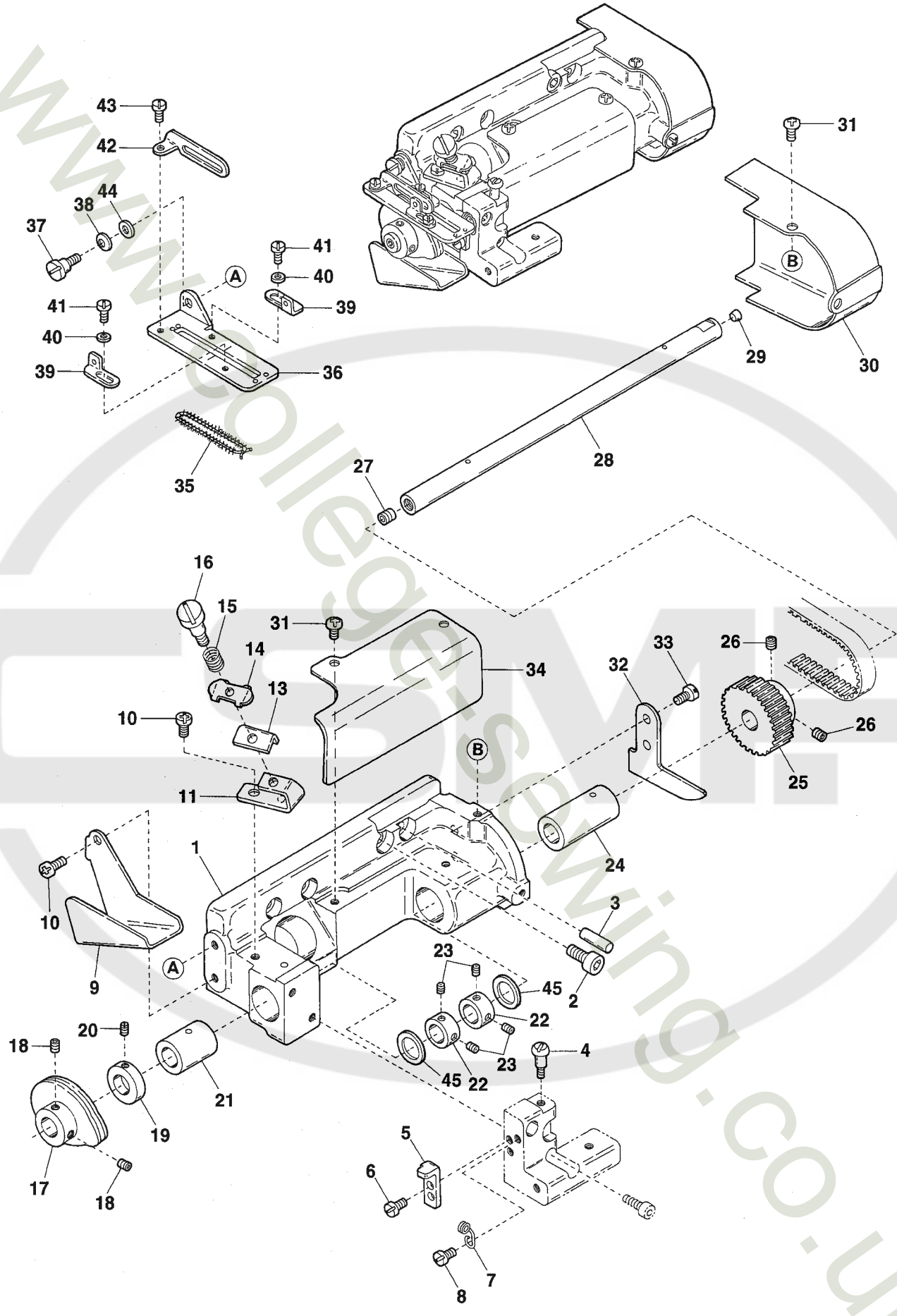

Ref.No	Parts No.	Description	品名	Amt. Req
1	3150005	Take-up Shaft Bracket	カム軸ブラケット	1
2	120013	Screw(M4-0.7 × 8)	止ネジ	2
3	000779	Knock Pin	ノックピン	2
4	190005	Screw(M4-0.7 × 5)	バネ掛ケネジ	1
5	3120073	Take-up Eyelet Support Stop	カム糸道取付板ストッパ	1
6	110041	Screw(M4-0.7 × 8)	止ネジ	2
7	3120074	Stop Spring	ストップバネ	1
8	110008	Screw(M4-0.7 × 5)	止ネジ	1
9	3150122	Looper Thread Take-up Cover	カムカバー	1
10	110013	Screw(M4-0.7 × 8)	止ネジ	2
11	3100087	Thread Retainer Support	小調子台	1
12				
13	0036175	Thread Retainer Disc Support	小調子板	1
14	0032425	Thread Retainer Disc	小調子皿	1
15	0032426	Thread Retainer Spring	小調子バネ	1
16	001093	Screw(1/8-44 × 2.2)	止ネジ	1
17	3120072	Looper Thread Take-up	下糸調子カム	1
18	006212	Screw(M5-0.8 × 6)	止ネジ	2
19	0032719	Collar(10 × 16 × 6mm)	カラー	1
20	001459	Screw(9/64-40 × 3)	止ネジ	1
21	3120060	Take-up Shaft Bushing(Left)	カム軸ブッシュ(左)	1
22	2100161	Collar(10 × 19 × 9mm)	カラー	2
23	160003	Screw(M5-0.8 × 5)	止ネジ	4
24	3120061	Take-up Shaft Bushing(Right)	カム軸ブッシュ(右)	1
25	3120068	Belt Pulley(Front)	ベルトプーリ(前)	1
26	160007	Screw(M6-1 × 6)	止ネジ	2
27	160015	Screw(M6-1 × 6)	止ネジ	1
28	3150153	Looper Thread Take-up Shaft	下糸調子カム軸	1
29	330007	Seal Plug	詰栓	1
30	3150134	Belt Cover(Small)	ベルトカバー(小)	1
31	004127	Screw(M4-0.7 × 6)	止ネジ	4
32	3150120	Belt Cover(Small/Left)	ベルトカバー(小)(左)	1
33	004127	Screw(M4-0.7 × 6)	止ネジ	2
34	3150135	Take-up Shaft Cover	カム軸カバー	1
35	000463	Laced Wire	モール	1
36	3150136	Looper Thread Take-up Eyelet Support	カム糸道取付板	1
37	170010	Screw(M4-0.7 × 4)	止ネジ	1
38	300100	Conical Spring Washer	皿バネワッシャ	1
39	0093515	Thread Eyelet	ルーバ糸道	2
40	000535	Washer	ワッシャ	2
41	110002	Screw(M3-0.5 × 5)	止ネジ	2
42	3120143	Cast-off Plate	ルーバ糸案内	1
43	110054	Screw(M3-0.5 × 3.5)	止ネジ	1
44	000669	Washer	ワッシャ	1
45	3160077	Thrust Plate	スラストプレート	2

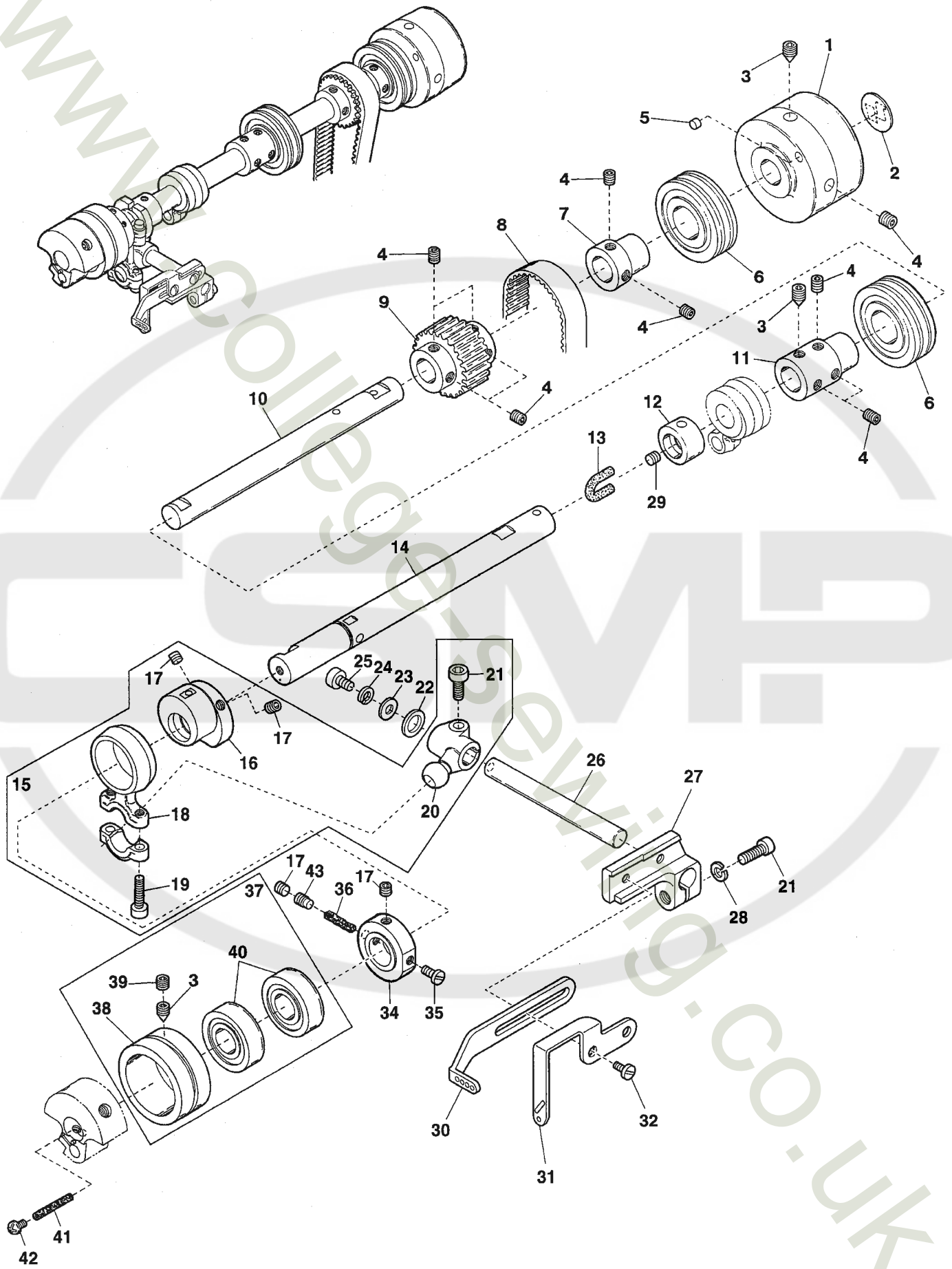

Ref.No	Parts No.	Description	品名	Amt. Req
1	3500051	Handwheel	ハンドホイール	1
2	000989	Handwheel Mark	ハンドホイールマーク	1
3	160005	Screw(M6-1 × 8)	止ネジ	3
4	160007	Screw(M6-1 × 6)	止ネジ	10
5	0092305	Magnet	マグネット	1
6	3500054	Ball Bearing	ボールベアリング	2
7	3100129	Handwheel Adapter	アダプタ	1
8	3510045	Timing Belt(550-5GT-12)	タイミングベルト	1
9	3260011	Upper Shaft Sprocket(Upper)	ベルトプーリ(上)	1
10	3100275	Upper Shaft(Right)	上軸(右)	1
11	3100283	Upper Shaft Joint	上軸継手	1
12	3500448	Oil Sleeve	オイルスリーブ	1
13	310040	Oil Wick	油芯	1
14	3510025	Upper Shaft(Left)	上軸(左)	1
15	3500444	Connecting Rod, C. Set	針糸繰りロッド(組)	1
16	3500445	Needle Thread Take-up Eccentric	針糸リエキセン	1
17	160003	Screw(M5-0.8 × 5)	止ネジ	4
18	3500446	Connecting Rod	針糸繰りロッド	1
19	120001	Screw(M4-0.7 × 14)	止ネジ	2
20	3500066	Driving Lever	針糸繰り軸腕	1
21	120013	Screw(M6-1 × 15)	止ネジ	2
22	2100218	Driving Shaft Thrust Ring	スラストリング	1
23	000555	Washer	ワッシャ	1
24	000600	Spring Washer	スプリングワッシャ	1
25	120015	Screw(M5-0.8 × 10)	止ネジ	1
26	3500065	Driving Shaft	針糸繰り軸	1
27	3500492	Bracket	針糸繰り台	1
28	000667	Spring Washer	スプリングワッシャ	1
29	160023	Screw(M4-0.7 × 4)	止ネジ	1
30	3180070	Needle Thread Take-up	針糸繰り糸道	1
31	3180075	Top Cover Thread Take-up	飾り糸繰り	1
32	110009	Screw(M4-0.7 × 8)	止ネジ	2
33				
34	3500442	Collar	カラー	1
35	110135	Screw(M5-0.8 × 7)	止ネジ	1
36	310132	Oil Wick(Φ 4.2 × 20mm)	油芯	1
37	3500062	Upper Shaft Sleeve, C. Set	上軸スリーブ(組)	1
38	3500064	Upper Shaft Sleeve	上軸スリーブ	1
39	160004	Screw(M6-1 × 4.8)	止ネジ	1
40	0093154	Ball Bearing	ボールベアリング	2
41	310099	Oil Wick(Φ 3.3 × 30mm)	油芯	1
42	110067	Screw(M5-0.8 × 5)	止ネジ	1
43	160041	Screw(M5-0.8 × 8)	止ネジ	1

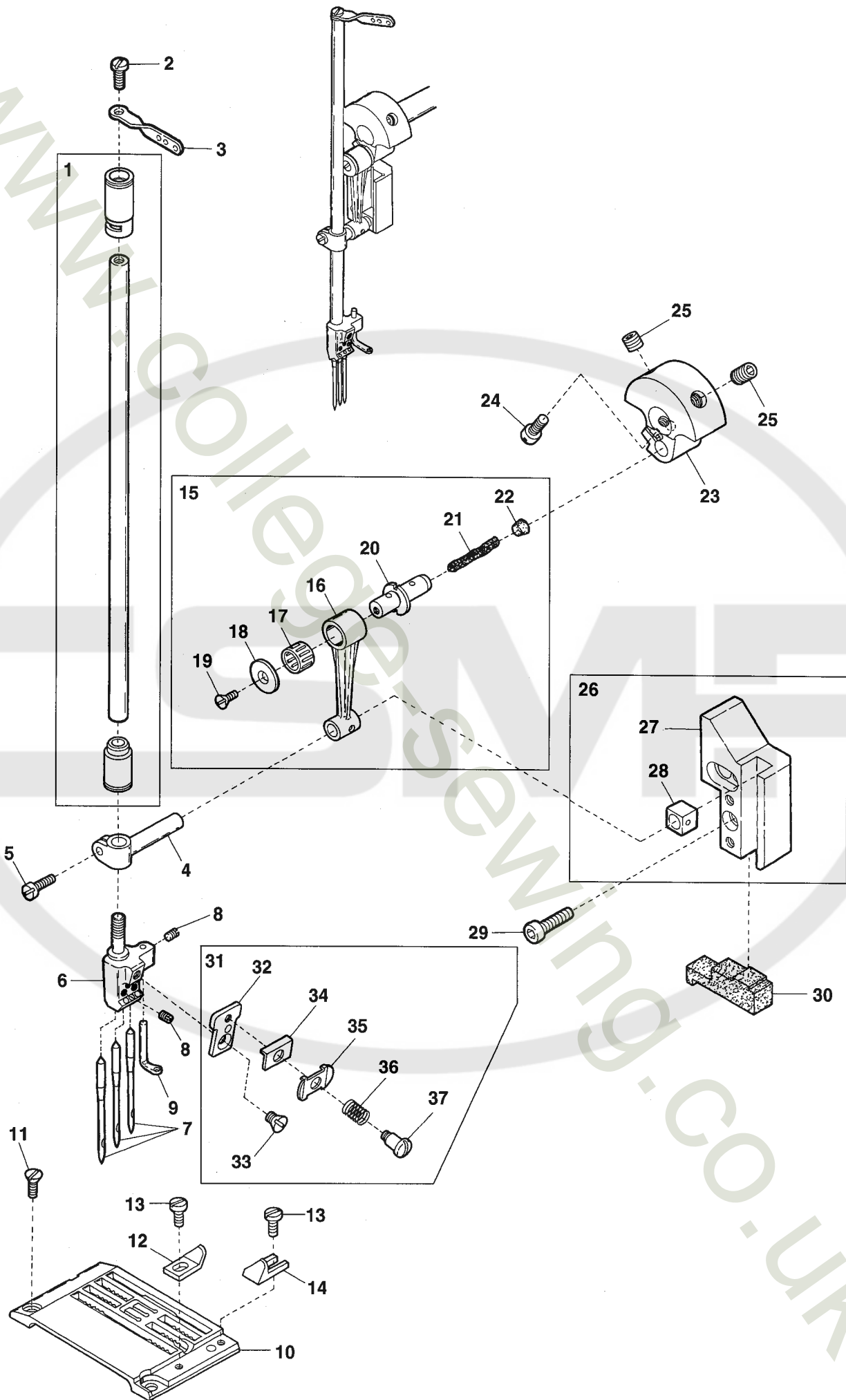

Ref.No	Parts No.	Description	品名	Amt. Req
1	3270015	Needle Bar & Needle Bar Bushing, C. Set	針棒・針棒ブッシュ(組)	1
2	004358	Screw(9/64-40 × 5.6)	止ネジ	1
3	0063044	Needle Bar Thread Eyelet	針棒糸道	1
4	3500100	Needle Bar Bracket	針棒抱キ	1
5	110035	Screw(M4-0.7 × 10)	止ネジ	1
6	0093357	Needle Clamp(56)	針止メ	1
7	-----	Needle(UY128 GAS)	針	3
8	001900	Screw(1/8-44 × 2.4)	止ネジ	4
9	0093365	Top Cover Thread Eyelet	飾り糸道	1
10	3158094	Stitch Plate(56S-2)	針板	1
11	110112	Screw(M3-0.5 × 5)	止ネジ	2
12	3520012	Fabric Guide(Left)	布ガイド(左)	1
13	001228	Screw(3/32-56 × 3.2)	止ネジ	2
14	3520013	Fabric Guide(Right)	布ガイド(右)	1
15	3500091	Connecting Rod, C. Set	針棒ロッド(組)	1
16	3200112	Connecting Rod	針棒ロッド	1
17	0093212	Roller Bearing	ニードルベアリング	1
18	3500617	Eccentric Pin Plate	エキセンピンプレート	1
19	130002	Screw(M3-0.5 × 6)	止ネジ	1
20	3500616	Eccentric Pin	針棒エキセンピン	1
21	000309	Felt(2.5 × 3 × 30mm)	フェルト	1
22	330000	Seal Plug	詰栓	1
23	3500615	Counterweight	バランスウエイト	1
24	110011	Screw(M5-0.8 × 10)	止ネジ	1
25	160029	Screw(M8-1.25 × 8)	止ネジ	2
26	3240015	Needle Bar Guide, C. Set	針棒案内(組)	1
27	3240016	Needle Bar Guide	針棒案内	1
28	0093186	Slide Block	針棒案内駒	1
29	009750	Screw(M4-0.7 × 20)	止ネジ	2
30	3100338	Sponge	給油スポンジ	1
31	3160190	Needle Thread Retainer Support, C. Set	小調子台(組)	1
32	3160191	Needle Thread Retainer Support	小調子台	1
33	005341	Screw(1/8-44 × 4.4)	止ネジ	1
34	0036175	Thread Retainer Disc Support	小調子板	1
35	0032425	Needle Thread Retainer Disc	小調子皿	1
36	0032426	Needle Thread Retainer Spring	小調子バネ	1
37	001093	Screw(1/8-44 × 22)	止ネジ	1

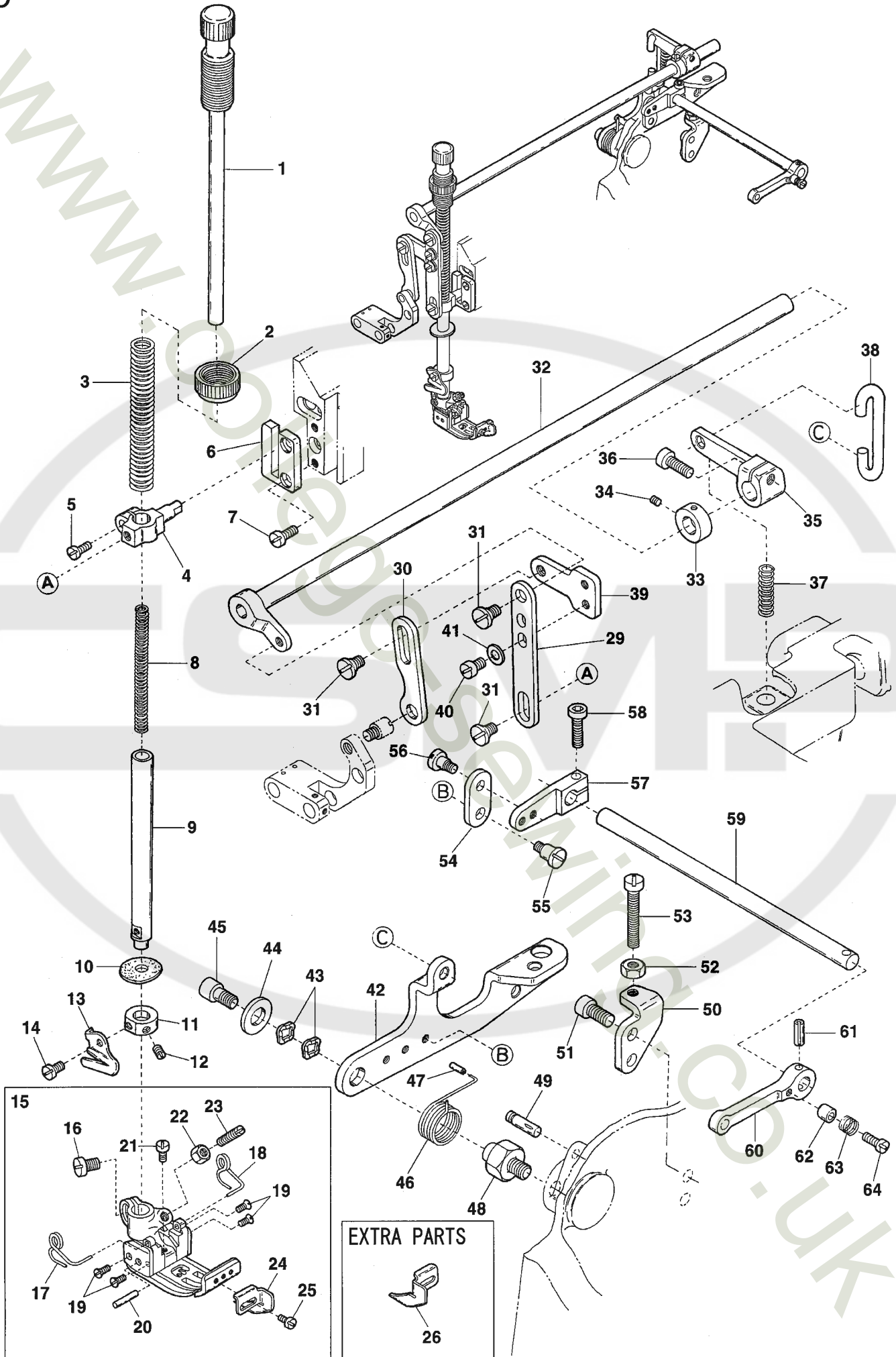

Ref.No	Parts No.	Description	品名	Amt. Req
1	0077270	Presser Spring Regulator	押工調節ネジ	1
2	000445	Lock Nut	ロックナット	1
3	0065372	Presser Bar Spring(Outer)	押工棒バネ(太)	1
4	3160163	Presser Bar Connecting Bracket	押工棒抱キ	1
5	110035	Screw(M4-0.7 × 10)	止ネジ	1
6	3240026	Presser Bar Guide	押工棒案内	1
7	110001	Screw(M4-0.7 × 5.4)	止ネジ	2
8	0060142	Presser Bar Spring(Inner)	押工棒バネ(細)	1
9	3100110	Presser Bar	押工棒	1
10	0093611	Oil Protector Ring	油切りリング	1
11	3100310	Collar(9 × 17 × 7mm)	カラー	1
12	150001	Screw(M4-0.7 × 4)	止ネジ	1
13	0020271	Thread Chain Cutting Knife	チェーンカッタ	1
14	110054	Screw(M3-0.5 × 3.5)	止ネジ	1
15	3167054	Presser Foot, C. Set (56)	押工(組)	1
16	110004	Screw(M3.5-0.6 × 8)	止ネジ	1
17	3107303	Presser Foot Spring(Left)	小押エバネ(左)	1
18	3107304	Presser Foot Spring(Right)	小押エバネ(右)	1
19	130016	Screw(M2.5-0.45 × 6)	止ネジ	4
20	3107306	Presser Foot Hinge Pin	押エヒンジピン	1
21	110084	Screw(M3.5-0.6 × 4.2)	止ネジ	1
22	000327	Lock Nut	ロックナット	1
23	260006	Adjusting Screw(1/8-44 × 9.5)	調節ネジ	1
24	3167057	Fabric Guide	布ガイド	1
25	008051	Screw(3/32-56 × 2.8)	止ネジ	1
26	3167058	Fabric Guide(Extra)	布ガイド(特注品)	1
27				
28				
29	3160090	Presser Bar Lifter Link	押工釣り	1
30	3510063	Guide Lifter Link	上送り台ガイド釣り	1
31	170041	Screw(M5-0.8 × 3.5)	止ネジ	3
32	3500300	Lifter Shaft	押工揚ゲ軸	1
33	2100267	Collar(10 × 17 × 8mm)	カラー	1
34	160001	Screw(M4-0.7 × 4)	止ネジ	2
35	3500293	Lifter Shaft Lever	押工揚ゲ軸レバー	1
36	005650	Screw(M5-0.8 × 14)	止ネジ	1
37	0068181	Spring	バネ	1
38	3500294	Lever Link	レバーリンク	1
39	3160091	Guide Lifter Link(Upper)	上送り台ガイド吊り(上)	1
40	110009	Screw(M4-0.7 × 8)	止ネジ	2

Ref. No. 41 to 64 See the following page.

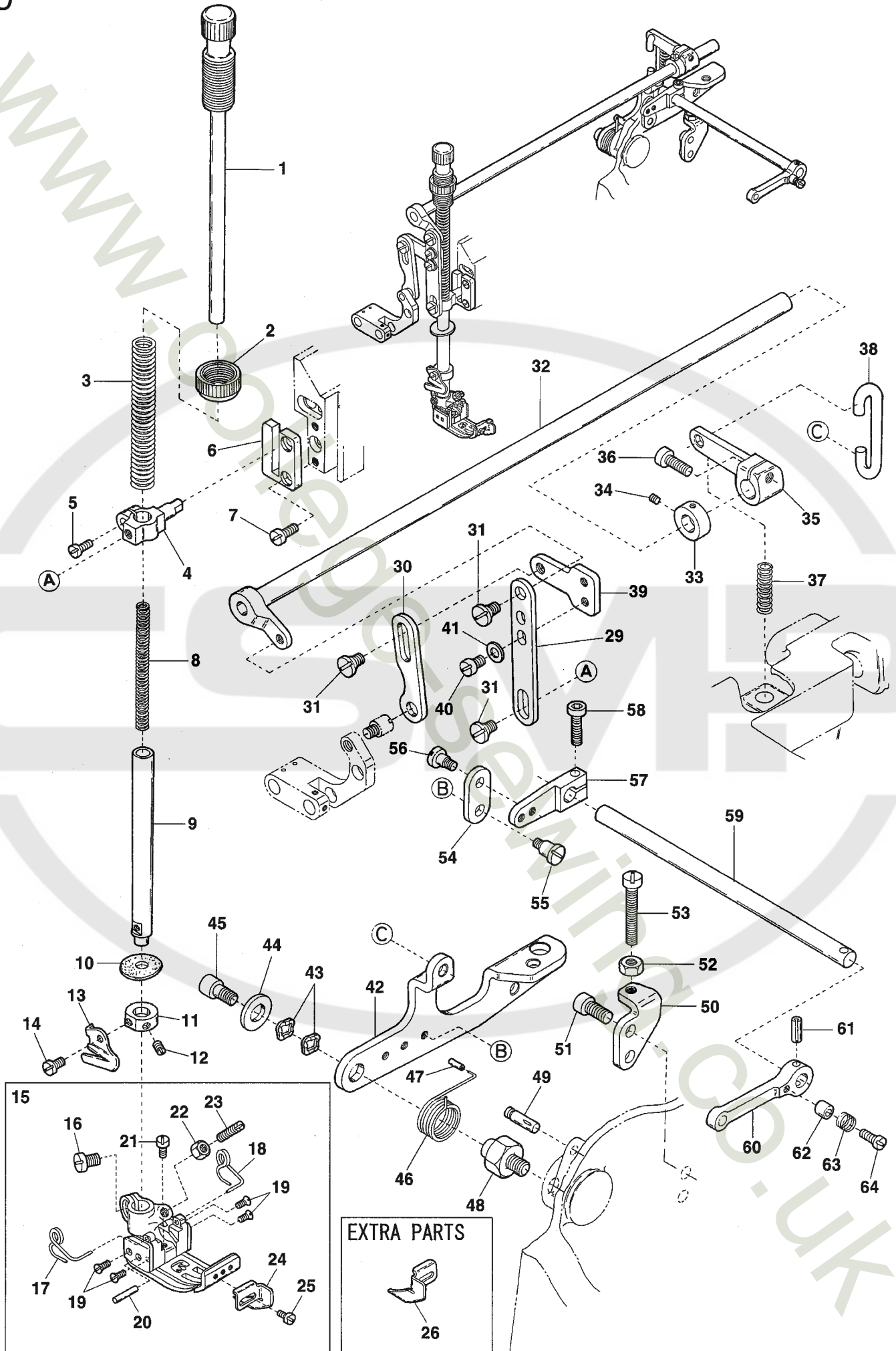

Ref.No	Parts No.	Description	品名	Amt. Req
41	000538	Washer	ワッシャ	2
42	3500291	Lifter Lever	押工揚グレバー	1
43	000487	Wave Washer	波形ワッシャ	2
44	300005	Washer	ワッシャ	1
45	120010	Screw(M6-1 × 10)	止ネジ	1
46	2110361	Spring	バネ	1
47	3500305	Cap	キャップ	1
48	2100194	Lifter Lever Holder	押工揚グレバー台	1
49	340003	Knock Pin(Φ5 × 20mm)	ノックピン	1
50	3500295	Lifter Lever Stopper	押工揚グレバーストッパ	1
51	120006	Screw(M6-1 × 12)	止ネジ	2
52	000206	Lock Nut	ロックナット	1
53	110021	Screw(M5-0.8 × 18)	止ネジ	1
54	3500299	Tension Release Lever Connector	糸緩メ腕連結板	1
55	170038	Screw(M4-0.7 × 5)	止ネジ	1
56	170009	Screw(M4-0.7 × 4)	止ネジ	1
57	3100533	Tension Release Lever	糸緩メ腕	1
58	120001	Screw(M4-0.7 × 14)	止ネジ	1
59	3500292	Tension Release Shaft	糸緩メ軸	1
60	0063515	Thread Pull-off Lever	糸緩メレバー	1
61	000690	Spring Pin(4 × 16mm)	スプリングピン	1
62	0094390	Tension Release Adjusting Eccentric	糸緩メ板調節コロ	1
63	0095334	Swing-proof Spring	防振バネ	1
64	001170	Screw(9/64-40 × 12)	止ネジ	1

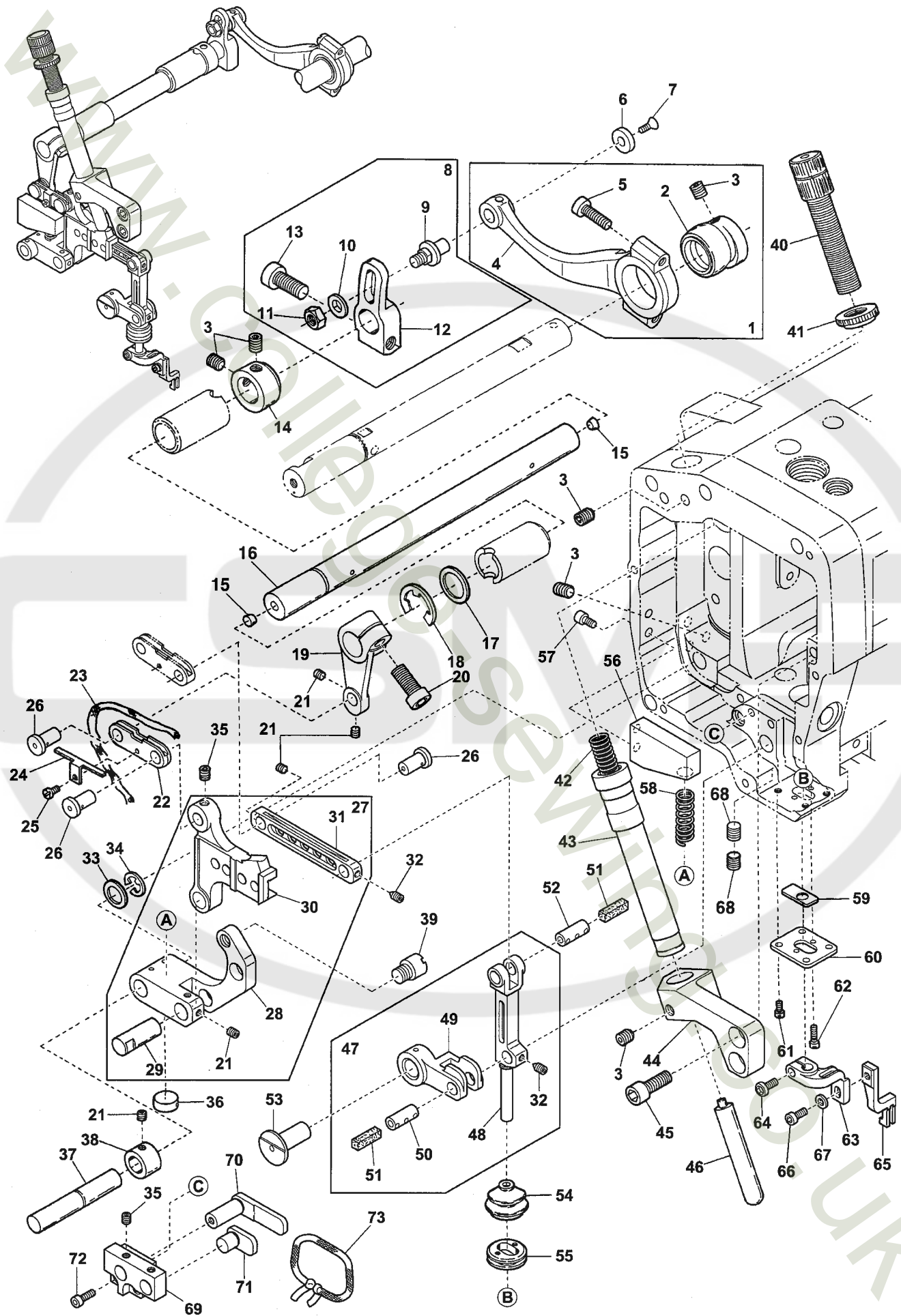

Ref.No	Parts No.	Description	品名	Amt. Req
1	3510017	Vertical Motion Connecting Rod, C. Set	上下ロッド(組)	1
2	3160034	Vertical Motion Eccentric	上下エキセン	1
3	160003	Screw(M5-0.8 × 5)	止ネジ	6
4	3510018	Vertical Motion Connecting Rod	上下ロッド	1
5	120049	Screw(M4-0.7 × 16)	止ネジ	2
6	3510029	Connecting Rod Pin Plate	ロッドピンプレート	1
7	130002	Screw(M3-0.5 × 6)	止ネジ	1
8	3510027	Vertical Motion Adjusting Arm, C. Set	上下調節腕(組)	1
9	3510028	Connecting Rod Pin	上下ロッドピン	1
10	300000	Washer	ワッシャ	1
11	000206	Nut	ナット	1
12	3160036	Vertical Motion Adjusting Arm	上下調節腕	1
13	120013	Screw(M6-1 × 15)	止ネジ	1
14	2100137	Collar(12 × 20 × 10mm)	カラー	1
15	000740	Seal Plug	詰栓	2
16	3160037	Vertical Motion Shaft	上送り上下軸	1
17	3160039	Thrust Plate	スラストプレート	1
18	3160038	Retaining Ring	ストップリング	1
19	3510038	Vertical Motion Rocking Arm	上送り上下振り腕	1
20	140004	Screw(M6-1 × 16)	止ネジ	1
21	160000	Screw(M3-0.5 × 3)	止ネジ	6
22	3510039	Rocking Arm Link	振り腕リンク	1
23	310068	Oil Wick(No.2-120mm)	油芯	1
24	3160098	Oil Wick Presser	油芯押エ	1
25	110023	Screw(M2-0.4 × 3.5)	止ネジ	1
26	3510037	Link Pin	リンクピン	3
27	3510020	Top Feed Dog Bar Guide, C. Set	上送り台ガイド(組)	1
28	3510021	Top Feed Dog Bar Guide Arm	上送り台ガイド腕	1
29	2100288	Guide Arm Pin	ガイド腕ピン	1
30	3510022	Top Feed Dog Bar Guide	上送り台ガイド	1
31	3510024	Top Feed Dog Bar	上送り台	1
32	160006	Screw(M3-0.5 × 6)	止ネジ	2
33	3160104	Thrust Plate	スラストプレート	1
34	0068202	Retaining Ring	ストップリング	1
35	160001	Screw(M4-0.7 × 4)	止ネジ	3
36	3160092	Guide Stop	上送り台ガイドストップ	1
37	3160103	Guide Arm Shaft	ガイド腕軸	1
38	3200086	Collar(8 × 13 × 6mm)	カラー	1
39	180033	Screw(M6-1 × 5)	止ネジ	1
40	004272	Adjusting Screw(M10-0.75 × 44)	調節ネジ	1

Ref. No. 41 to 73 See the following page.

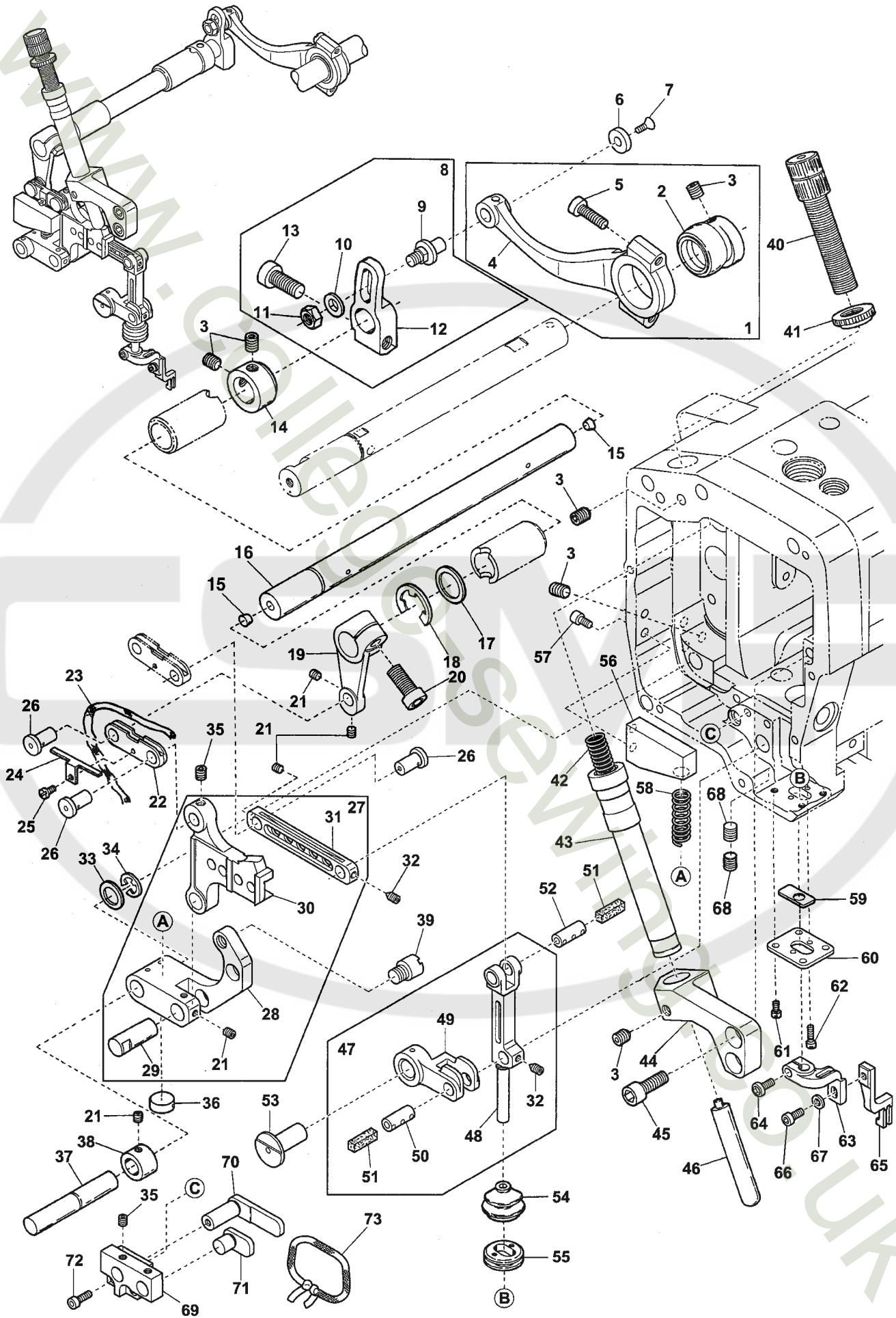

Ref.No	Parts No.	Description	品名	Amt. Req
41	100007	Lock Nut	ロックナット	2
42	3510062	Top Feed Dog Press Spring	上送り押エバネ	1
43	3510059	Top Feed Dog Bar Bushing	上送り棒ブッシュ	1
44	3510060	Top Feed Dog Bar Bushing Holder	上送り棒ブッシュ台	1
45	005650	Screw(M5-0.8 × 14)	止ネジ	2
46	3160124	Top Feed Dog Presser Bar	上送り台押エ棒	1
47	3510030	Top Feed Dog Bar, C. Set	上送り棒(組)	1
48	3510031	Top Feed Dog Bar	上送り棒	1
49	3510032	Top Feed Dog Bar Link	上送り棒リンク	1
50	3510034	Top Feed Dog Bar Link Pin	上送り棒リンクピン	1
51	000278	Oil Wick(2.5 × 2.5 × 18mm)	油芯	2
52	2100176	Top Feed Dog Bar Pin	上送り棒ピン	1
53	3510033	Top Feed Dog Link Pin	上送りリンクピン	1
54	3160120	Oil Leakage Proof Cover	防油カバー	1
55	3160114	Cover Support	防油カバーサポート	1
56	3510040	Spring Holder	バネ受け台	1
57	009747	Screw(M4-0.7 × 10)	止ネジ	2
58	3510041	Auxiliary Top Feed Dog Spring	上送り補助バネ	1
59	3160116	Top Feed Dog Bar Seal	上送り棒シール	1
60	3510057	Seal Support	シールサポート	1
61	110002	Screw(M2-0.4 × 5)	止ネジ	4
62	110115	Screw(M2-0.4 × 8.5)	止ネジ	2
63	3510035	Top Feed Dog Holder	上送り取付台	1
64	190077	Screw(M4-0.7 × 10)	止ネジ	1
65	3519012	Top Feed Dog	上送り	1
66	009779	Screw(M3-0.5 × 6)	止ネジ	1
67	000014	Washer	ワッシャ	1
68	160007	Screw(M5-0.8 × 6)	止ネジ	2
69	3510043	Guid Bracket	ガイドブラケット	1
70	3510044	Top Feed Dog Bar Guid(Right)	上送り棒ガイド(右)	1
71	3160109	Top Feed Dog Bar Guid(Left)	上送り棒ガイド(左)	1
72	120001	Screw(M4-0.7 × 14)	止ネジ	2
73	310035	Oil Wick	油芯	1

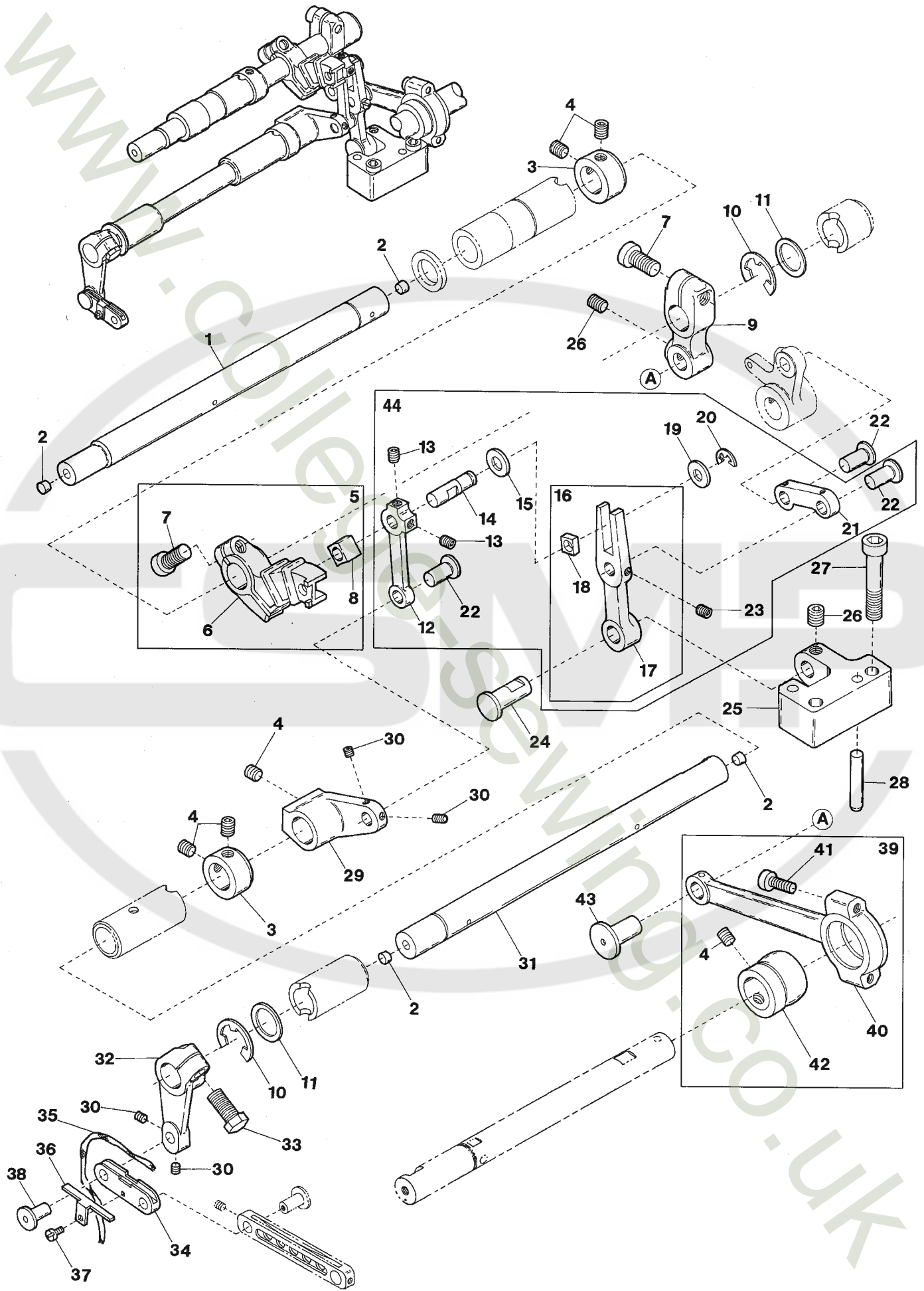

Ref.No	Parts No.	Description	品名	Amt. Req
1	3160173	Top Feed Rocker Drive Shaft	上送り前後駆動軸	1
2	000740	Seal Plug	詰栓	4
3	2100137	Collar(12 × 20 × 10mm)	カラー	2
4	160003	Screw(M5-0.8 × 5)	止ネジ	8
5	3160056	Top Feed Arm, Complete Set	上送り調節腕(組)	1
6	3160057	Top Feed Regulator Arm	上送り調節腕	1
7	120013	Screw(M6-1 × 15)	止ネジ	2
8	3160058	Slider	スライダ	1
9	3160051	Rocker Shaft Lever	上送り前後軸腕	1
10	3160038	Retaining Ring	ストップリング	2
11	3160039	Thrust Plate	スラストプレート	2
12	3160064	Top Feed Rocker Arm Link	前後送り腕リンク	1
13	160001	Screw(M4-0.7 × 4)	止ネジ	2
14	2120082	Slider Pin	スライダピン	1
15	0026413	Spacer	スペーサ	1
16	3160061	Slider Lever, C. Set	スライダレバー(組)	1
17	3160062	Slider Lever	スライダレバー	1
18	0026099	Slider Lever Block	角駒	1
19	2120083	Spacer	スペーサ	1
20	0033024	Retaining Ring	ストップリング	1
21	3160063	Slider Link	スライダリンク	1
22	0026081	Link Pin	リンクピン	3
23	160030	Screw(M3.5-0.6 × 3)	止ネジ	1
24	3160071	Slider Lever Pin	スライダレバーピン	1
25	3160070	Slider Lever Holder	スライダレバー台	1
26	160007	Screw(M6-1 × 6)	止ネジ	2
27	009977	Screw(M6-1 × 30)	止ネジ	2
28	3100207	Pin(5 × 12mm)	ピン	2
29	3160065	Top Feed Rocker Arm(Right)	上送り前後腕(右)	1
30	160000	Screw(M3-0.5 × 3)	止ネジ	4
31	3160066	Top Feed Rocker Shaft	上送り前後軸	1
32	3510023	Top Feed Rocking Arm	上送り前後振り腕	1
33	140004	Screw(M6-1 × 16)	止ネジ	1
34	3510039	Rocking Arm Link	振り腕リンク	1
35	310068	Oil Wick(No.2-120mm)	油芯	1
36	3160098	Oil Wick Presser	油芯押エ	1
37	110023	Screw(M2-0.4 × 3.5)	止ネジ	1
38	3510037	Link Pin	リンクピン	1
39	3160049	Driving Connecting Rod, C. Set	上送り前後ロッド(組)	1
40	3160050	Driving Connecting Rod	上送り前後ロッド	1
41	120049	Screw(M4-0.7 × 16)	止ネジ	2
42	3160054	Top Feed Eccentric	送りエキセン	1
43	3160052	Top Feed Dog Link Pin	上送りリンクピン	1
44	3160060	Slider Lever, C. Set 2	スライダレバー(組2)	1

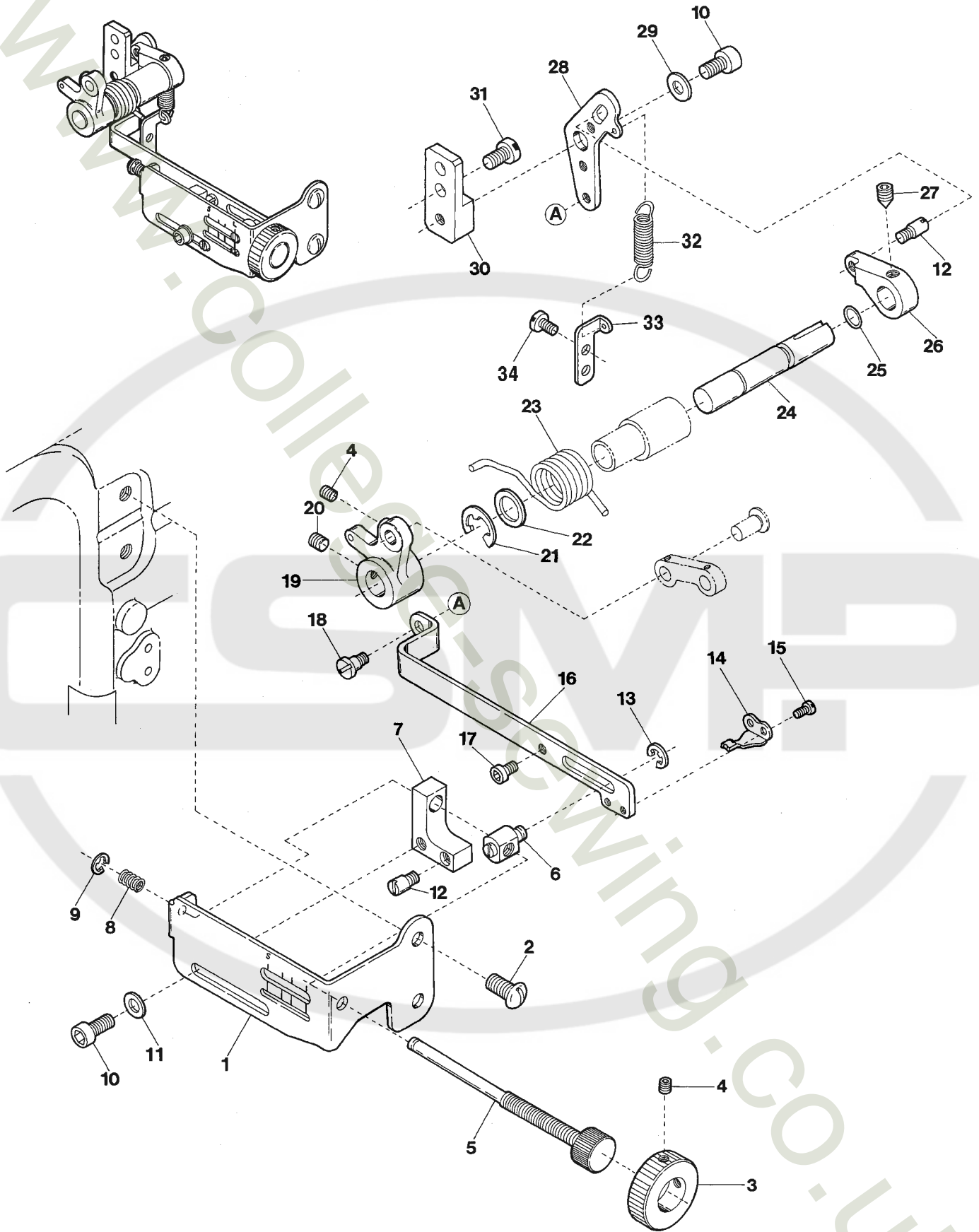

Ref.No	Parts No.	Description	品名	Amt. Req
1	3160085	Differential Feed Graduations	上送り目盛板	1
2	009784	Screw(M6-1 × 10)	止ネジ	2
3	3160086	Adjusting Knob	調節ツマミ	1
4	160001	Screw(M4-0.7 × 4)	止ネジ	3
5	3240091	Adjusting Screw	調節ネジ	1
6	3240087	Adjusting Pin	調節ピン	1
7	3160088	Stop Block	ストップブロック	1
8	2100259	Adjusting Spring	調節バネ	1
9	0034293	Retaining Ring	ストップリング	1
10	009751	Screw(M5-0.8 × 10)	止ネジ	2
11	000669	Washer	ワッシャ	1
12	180012	Screwed Pin(M4-0.7 × 3)	ピンネジ	2
13	0077179	Retaining Ring	ストップリング	1
14	3240086	Differential Feed Pointer	上送り量指針	1
15	110054	Screw(M3-0.5 × 3.5)	止ネジ	2
16	3160084	Adjusting Outer Link	上送り前後外リンク	1
17	006202	Screw(M4-0.7 × 6)	止ネジ	1
18	170010	Screw(M4-0.7 × 4)	止ネジ	1
19	3160073	Slider Link Lever	スライダリンクレバー	1
20	160003	Screw(M5-0.8 × 5)	止ネジ	2
21	0095027	Retaining Ring	ストップリング	1
22	3160077	Thrust Plate	スラストプレート	1
23	3160074	Adjusting Lever Spring	レバーバネ	1
24	3160076	Adjusting Shaft	前後調節軸	1
25	0020538	O-ring(P7)	Oリング	1
26	3160080	Top Feed Dog Adjusting Lever	上送り前後レバー	1
27	160021	Screw(M5-0.8 × 6)	止ネジ	1
28	3160082	Adjusting Lever Hinge	上送り前後レバーヒンジ	1
29	000426	Washer	ワッシャ	1
30	3160081	Hinge Holder	ヒンジ台	1
31	110011	Screw(M5-0.8 × 10)	止ネジ	2
32	0085710	Spring	バネ	1
33	3510055	Spring Latch	バネ掛ケ	1
34	110094	Screw(M4-0.7 × 6)	止ネジ	2

Ref.No	Parts No.	Description	品名	Amt. Req
1	3500081	Spreader Eccentric, C. Set	飾リエキセン(組)	1
2	3500082	Spreader Eccentric	飾リエキセン	1
3	160003	Screw(M5-0.8 × 5)	止ネジ	2
4	3500084	Spreader Connecting Rod	飾リロッド	1
5	110009	Screw(M4-0.7 × 8)	止ネジ	1
6	300006	Washer	ワッシャ	1
7	3100309	Adjusting Lever Pin	調節レバーピン	1
8	000528	Washer	ワッシャ	1
9	100003	Nut(M6-1.0)	ナット	1
10	3500086	Spreader Adjusting Lever	飾リ調節レバー	1
11	120013	Screw(M6-1 × 15)	止ネジ	1
12	3160138	Driving Shaft	ルーパ軸	1
13	0032646	Collar(12 × 20 × 8mm)	カラー	1
14	009604	Screw(11/64-40 × 5.5)	止ネジ	2
15				
16	3100305	Rocking Arm	ルーパ振り腕	1
17	160007	Screw(M6-1 × 6)	止ネジ	2
18	0063051	Rocking Pin	ルーパ振りピン	1
19	310094	Oil Wick(φ 3.3 × 15mm)	油芯	1
20	0063053	Spreader Bar	ルーパ棒	1
21	0063056	Bushing Ring	ブッシュリング	1
22	0063057	Collar(10 × 18 × 7mm)	カラー	1
23	009526	Screw(9/64-40 × 4.4)	止ネジ	2
24	3100307	Spreader Holder	飾り糸ルーパ台	1
25	3509320	Spreader	飾り糸ルーパ	1
26	110031	Screw(M4-0.7 × 12)	止ネジ	2
27	2100218	Thrust Ring	スラストリング	1
28	3500097	Thrust Sheet(Small)	スラストシート(小)	1

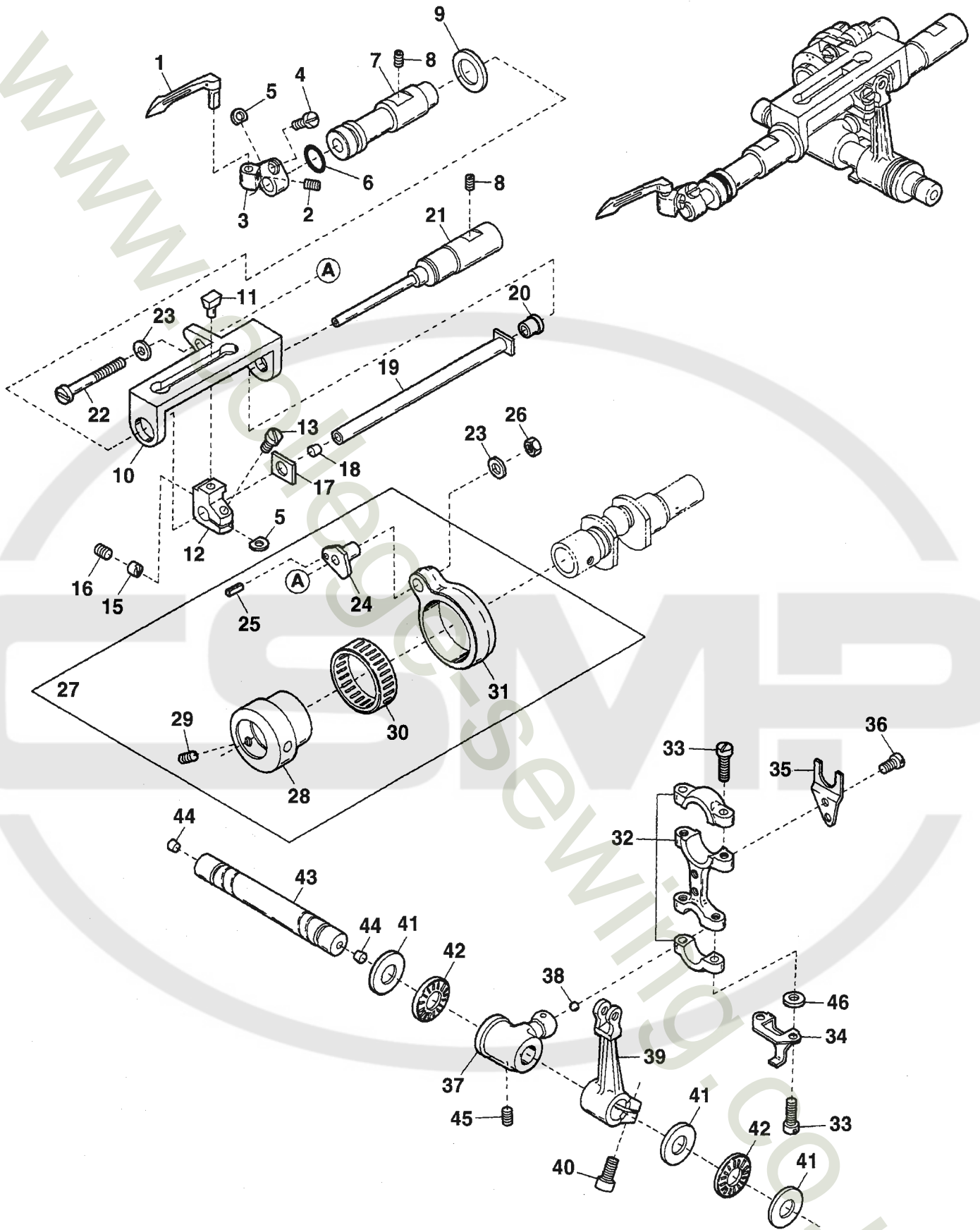

Ref.No	Parts No.	Description	品名	Amt. Req
1	3109300	Looper	ルーパ	1
2	160040	Screw(M4-0.7 × 5)	止ネジ	1
3	3150170	Looper Holder	ルーパ台	1
4	110039	Screw(M3.5-0.6 × 10)	止ネジ	1
5	300500	Spacer(Fiber)	スペーサ(ファイバ)	2
6	3100205	O-ring(P12)	Oリング	1
7	3150060	Looper Bar Bushing	ルーパ棒ブッシュ	1
8	160024	Screw(M6-1 × 8)	止ネジ	2
9	3100156	Bushing Spacer	ブッシュスペーサ	1
10	3100152	Looper Bar Guide	ルーパ棒ガイド	1
11	3100157	Slider	スライダ	1
12	3100158	Slider Holder	スライダ取付台	1
13	110005	Screw(M3.5-0.6 × 12)	止ネジ	1
14				
15	3100159	Slider Presser	スライダ押し	1
16	160001	Screw(M4-0.7 × 4)	止ネジ	1
17	3100160	Thrust Washer	スラストワッシャ	1
18	330002	Seal Plug(Cork)	詰栓(コルク)	1
19	3100161	Looper Bar	ルーパ棒	1
20	3100153	Guide Shaft Bushing	ガイド軸ブッシュ	1
21	3100155	Looper Bar Guide Shaft	ガイド軸	1
22	110019	Screw(M5-0.8 × 35)	止ネジ	1
23	300000	Washer	ワッシャ	2
24	3100151	Looper Rocker Adjusting Pin	ルーパ前後調節ピン	1
25	340001	Roll Pin	ロールピン	1
26	100002	Nut	ナット	1
27	3100150	Looper Rocker Connecting Rod, C. Set	ルーパ前後ロッド(組)	1
28	3100147	Looper Rocker Regulating Eccentric	ルーパ前後エキセン	1
29	160003	Screw(M5-0.8 × 5)	止ネジ	1
30	0065389	Roller Bearing	ニードルベアリング	1
31	3100149	Looper Rocker Connecting Rod	ルーパ前後ロッド	1
32	3100140	Looper Connecting Rod	ルーパロッド	1
33	005071	Screw(11/64-32 × 14)	止ネジ	4
34	3100355	Oil Splasher	オイルスプラッシャ	1
35	3100141	Guide Fork	振れ止め	1
36	004440	Screw(11/64-40 × 8.3)	止ネジ	2
37	3100142	Looper Driving Lever	ルーパ軸腕	1
38	000637	Seal Plug	詰栓	1
39	3100143	Looper Rocker Arm	ルーパ振り腕	1
40	120011	Screw(M6-1 × 18)	止ネジ	1
41	3100146	Thrust Plate	スラストプレート	3
42	3100145	Thrust Roller Bearing	スラストベアリング	2
43	3100144	Looper Shaft	ルーパ軸	1
44	000740	Seal Plug	詰栓	2
45	160029	Screw(M8-1.25 × 8)	止ネジ	2
46	001123	Washer	ワッシャ	2

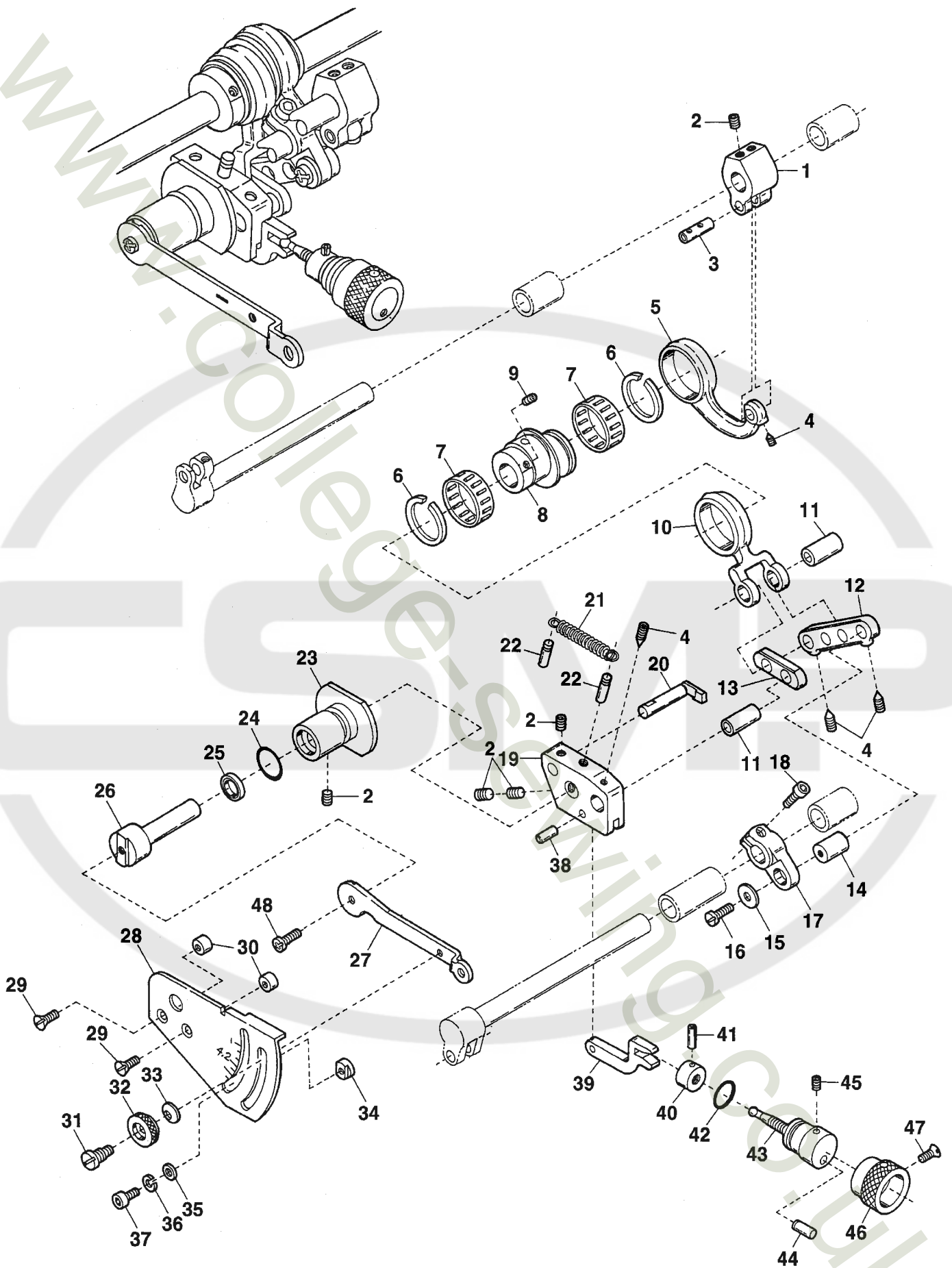

Ref.No	Parts No.	Description	品名	Amt. Req
1	3100217	Feed Lift Lever	送り上下軸腕	1
2	160007	Screw(M6-1 × 6)	止ネジ	6
3	0032799	Connecting Rod Pin	ロッドピン	1
4	160002	Screw(M4-0.7 × 2)	止ネジ	4
5	3150040	Feed Lift Connecting Rod	送り上下ロッド	1
6	3100192	Retaining Ring	止メ輪	2
7	3100190	Roller Bearing	ニードルベアリング	2
8	3100189	Feed Eccentric	送りエキセン	1
9	006212	Screw(M5-0.8 × 6)	止ネジ	2
10	3100191	Feed Connecting Rod	送りロッド	1
11	3100193	Connecting Rod Pin	ロッドピン	2
12	3100194	Lever Link(Long)	送りレバーリンク(長)	1
13	3100195	Lever Link(Short)	送りレバーリンク(短)	1
14	3100196	Lever Link Pin	送りレバーリンクピン	1
15	300006	Washer	ワッシャ	1
16	110009	Screw(M4-0.7 × 8)	止ネジ	1
17	3100197	Feed Shaft Lever	送り軸レバー	1
18	120009	Screw(M4-0.7 × 12)	止ネジ	1
19	3100199	Control Bracket	送り調節ブラケット	1
20	3100202	Connecting Rod Guide	送りロッドガイド	1
21	3100200	Control Bracket Spring	ブラケットバネ	1
22	340003	Pin	ピン	2
23	3100103	Control Lever Shaft Bushing	調節レバー軸ブッシュ	1
24	3100104	O-ring(P16)	Oリング	1
25	0093303	Oil Seal	オイルシール	1
26	3150068	Control Lever Shaft	送り調節レバー軸	1
27	3100210	Feed Control Lever	送り調節レバー	1
28	3150157	Feed Graduations	送り目盛板	1
29	130004	Screw(M4-0.7 × 11)	止ネジ	2
30	000505	Spacer	スペーサ	2
31	190004	Screw(M6-1 × 7.5, M4.5-0.5 × 3)	止ネジ	1
32	100005	Nut	ナット	1
33	000561	Conical Spring Washer	皿バネワッシャ	1
34	0020350	Control Lever Stop	送り調節レバーストップ	1
35	000669	Washer	ワッシャ	1
36	000600	Spring Washer	スプリングワッシャ	1
37	005049	Screw(M5-0.8 × 8)	止ネジ	1
38	3100211	Control Link Pin	送り調節リンクピン	1
39	3100203	Control Link	送り調節リンク	1
40	3100208	Control Nut	送り調節ナット	1
41	001107	Roll Pin	ロールピン	1
42	3100205	O-ring(P12)	Oリング	1
43	3100204	Adjusting Screw	調節ネジ	1
44	3100207	Adjusting Stop Pin	ストップピン	1
45	160001	Screw(M4-0.7 × 4)	止ネジ	1
46	3100206	Adjusting Knob	調節ツマミ	1
47	130011	Screw(M3-0.5 × 4)	止ネジ	1
48	110013	Screw(M4-0.7 × 8)	止ネジ	1

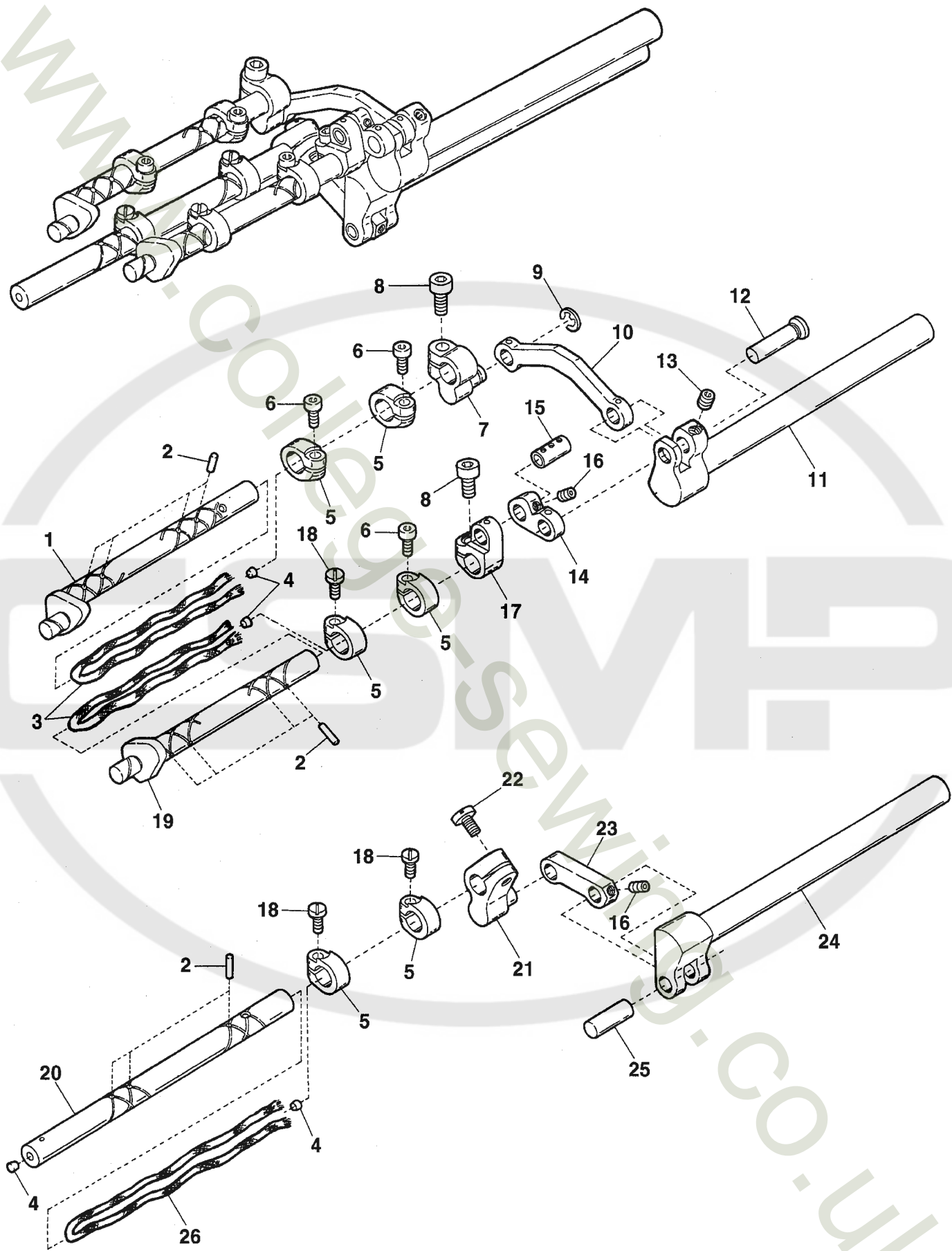

Ref.No	Parts No.	Description	品名	Amt. Req
1	3150034	Feed Lift Shaft(Rear)	送り上下軸(後)	1
2	000397	Oil Wick	油芯	11
3	310035	Oil Wick(2-165mm)	油芯	2
4	330009	Seal Plug	詰栓	4
5	3150030	Collar(8 × 12 × 6mm)	カラー	6
6	120047	Screw(M3-0.5 × 8)	止ネジ	3
7	3150032	Feed Lift Lever(Rear)	送り上下軸腕(後)	1
8	120018	Screw(M4-0.7 × 10)	止ネジ	1
9	0033024	Retaining Ring	ストップリング	1
10	3150031	Feed Lift Connecting Link(Right)	送り上下リンク(右)	1
11	3150022	Feed Lift Shaft	送り上下軸	1
12	3150024	Feed Lift Connecting Link Pin(Front)	送り上下リンクピン(前)	1
13	003657	Screw(M4-0.7 × 3)	止ネジ	1
14	3150025	Feed Lift Connecting Link(Left)	送り上下リンク(左)	1
15	2100620	Feed Lift Connecting Link Pin(Left)	送り上下リンクピン(左)	1
16	160000	Screw(M4-0.5 × 3)	止ネジ	2
17	3150027	Feed Lift Lever(Left)	送り上下軸腕(左)	1
18	110022	Screw(M3-0.5 × 10)	止ネジ	3
19	3150028	Feed Lift Shaft(Front)	送り上下軸(前)	1
20	3150048	Feed Rocker Shaft(Left)	送り前後軸(左)	1
21	3150047	Feed Rocker Lever(Rear)	送り前後腕(後)	1
22	120008	Screw(M4-0.7 × 8)	止ネジ	1
23	3150045	Feed Rocker Connecting Link	送リ前後リンク	1
24	3150041	Feed Rocker Shaft(Right)	送り前後軸(右)	1
25	3150043	Feed Rocker Connecting Link Pin(Front)	送リ前後リンクピン(前)	1
26	310078	Oil Wick(2-260mm)	油芯	1

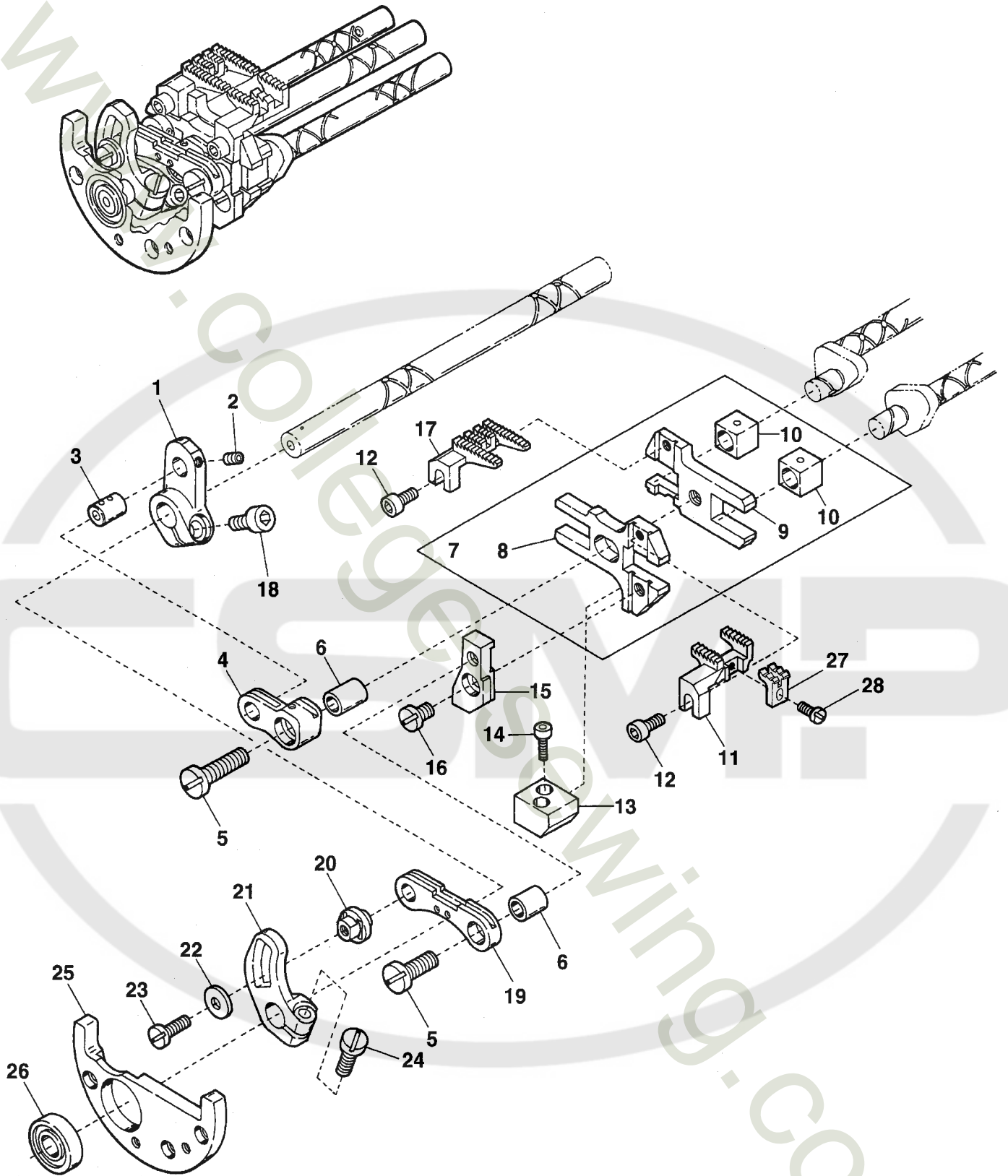

Ref.No	Parts No.	Description	品名	Amt. Req
1	3150051	Main Feed Rocker Lever	後送り前後腕	1
2	160000	Screw(M4-0.5 × 3)	止ネジ	1
3	3150052	Driving Connection Pin	送りリンクピン	1
4	3150053	Main Feed Bar Driving Connection	後送り前後リンク	1
5	110092	Screw(M5-0.8 × 14.5)	止ネジ	2
6	3150054	Driving Connection Bushing	送りリンクブッシュ	2
7	3150184	Feed Bar/Lift Block, C. Set	送り台角駒(組)	1
8	3150187	Differential Feed Bar	前送り台	1
9	3150186	Main Feed Bar	後送り台	1
10	3150062	Feed Lift Block	角駒	2
11	3159043	Differential Feed Dog(56S)	前送り	1
12	120047	Screw(M3-0.5 × 8)	止ネジ	2
13	3150067	Feed Bar Guide	送り台ガイド	1
14	120007	Screw(M3-0.5 × 10)	止ネジ	2
15	3150066	Feed Bar Plate	送り台補助板	1
16	007627	Screw(M4-0.7 × 6)	止ネジ	1
17	3159037	Main Feed Dog(56S)	後送り	1
18	120018	Screw(M4-0.7 × 10)	止ネジ	1
19	3150057	Differential Feed Bar Driving Connection	前送り前後リンク	1
20	3150056	Differential Feed Adjusting Pin	前送り前後調節ピン	1
21	3150055	Differential Feed Rocker Lever	前送り前後腕	1
22	300048	Washer	ワッシャ	1
23	110004	Screw(M3.5-0.6 × 8)	止ネジ	1
24	110035	Screw(M4-0.7 × 10)	止ネジ	1
25	3150098	Bearing Housing	ベアリングハウジング	1
26	3150059	Ball Bearing	ボールベアリング	1
27	3159019	Differential Feed Dog(Middle)(56S)	中送り	1
28	110038	Screw(M2.5-0.45 × 4.5)	止ネジ	1

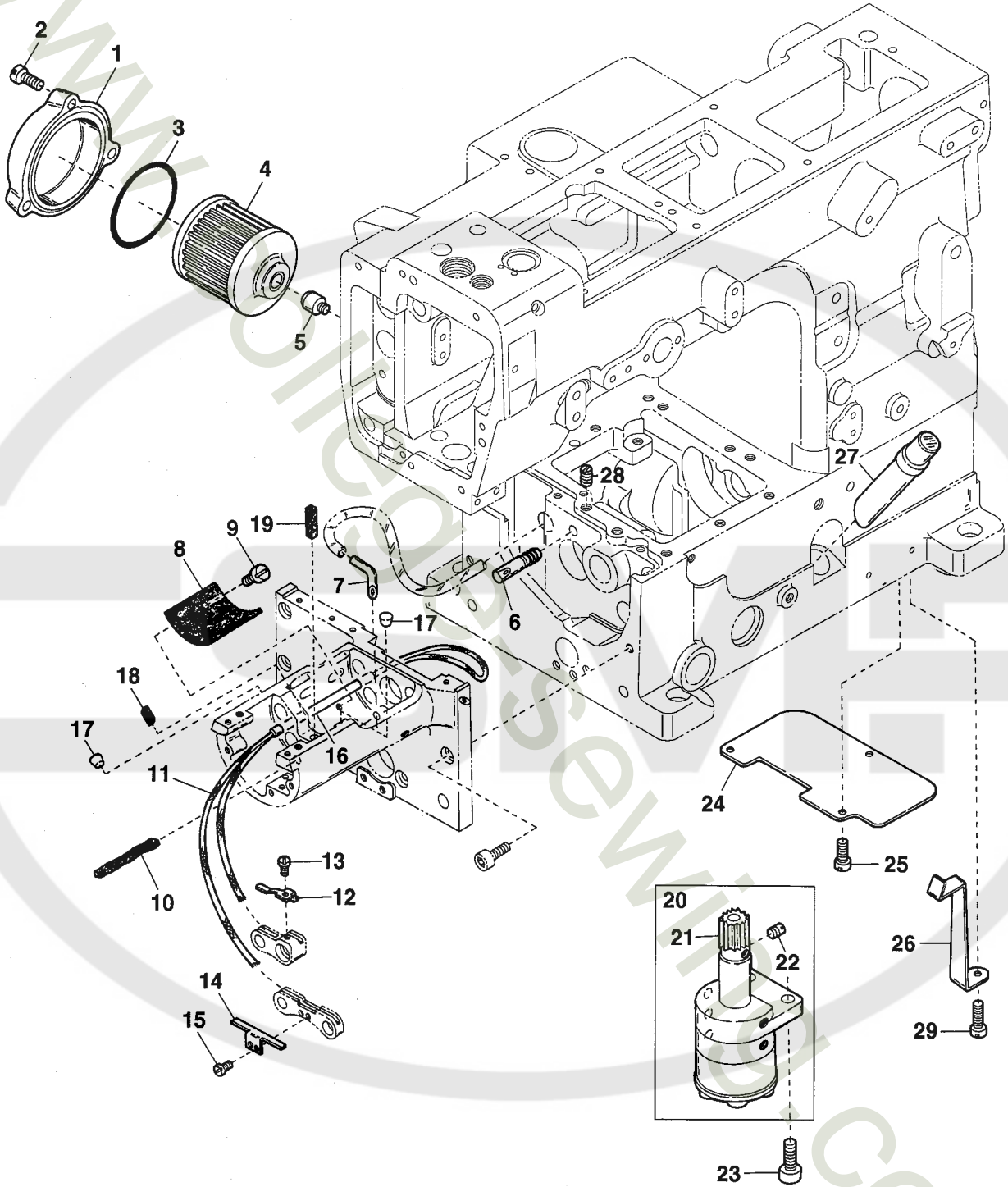

Ref.No	Parts No.	Description	品名	Amt. Req
1	3100060	Oil Filter Cap	オイルフィルタキャップ	1
2	110045	Screw(M4-0.7 × 12)	止ネジ	3
3	3100061	O-ring(P42)	Oリング	1
4	3100345	Oil Filter	オイルフィルタ	1
5	3100329	Oil Filter Connector	オイルフィルタ継手	1
6	3150138	Lower Shaft Oiling Outlet	下軸給油管	1
7	3150156	Suction Pipe	吸入パイプ	1
8	3150142	Cylinder Felt	シリンダフェルト	1
9	110054	Screw(M3-0.5 × 3.5)	止ネジ	2
10	000304	Felt(2.5 × 3 × 60)	フェルト	1
11	310077	Oil Wick	油芯(2号500mm)	1
12	3150077	Oil Wick Clamp(Short)	油芯押エ(短)	1
13	110027	Screw(M2.5-0.45 × 3.5)	止ネジ	1
14	3150078	Oil Wick Presser(Long)	油芯押エ(長)	1
15	110023	Screw(M2-0.4 × 3.5)	止ネジ	2
16	3150154	Pipe	油芯パイプ	1
17	330009	Seal Plug	詰栓	2
18	310054	Felt(2.3 × 2.3 × 6)	フェルト	1
19	310047	Felt(2.3 × 2.3 × 11.5)	フェルト	1
20	3150143	Oil Pump, Complete Set	ポンプ(組)	1
21	0030711	Oil Pump Driving Worm Gear	ウォームギア	1
22	160001	Screw(M4-0.7 × 4)	止ネジ	3
23	120011	Screw(M6-1 × 15)	止ネジ	2
24	3150155	Dust Proof Plate	防塵板	1
25	110012	Screw(M4-0.7 × 5)	止ネジ	3
26	3100330	Oil Tube Stay	オイルパイプ支エ	1
27	3150189	Oil Sight Gauge	オイルゲージ	1
28	009736	Screw(M4-0.7 × 6)	止ネジ	1
29	110013	Screw(M4-0.7 × 8)	止ネジ	1

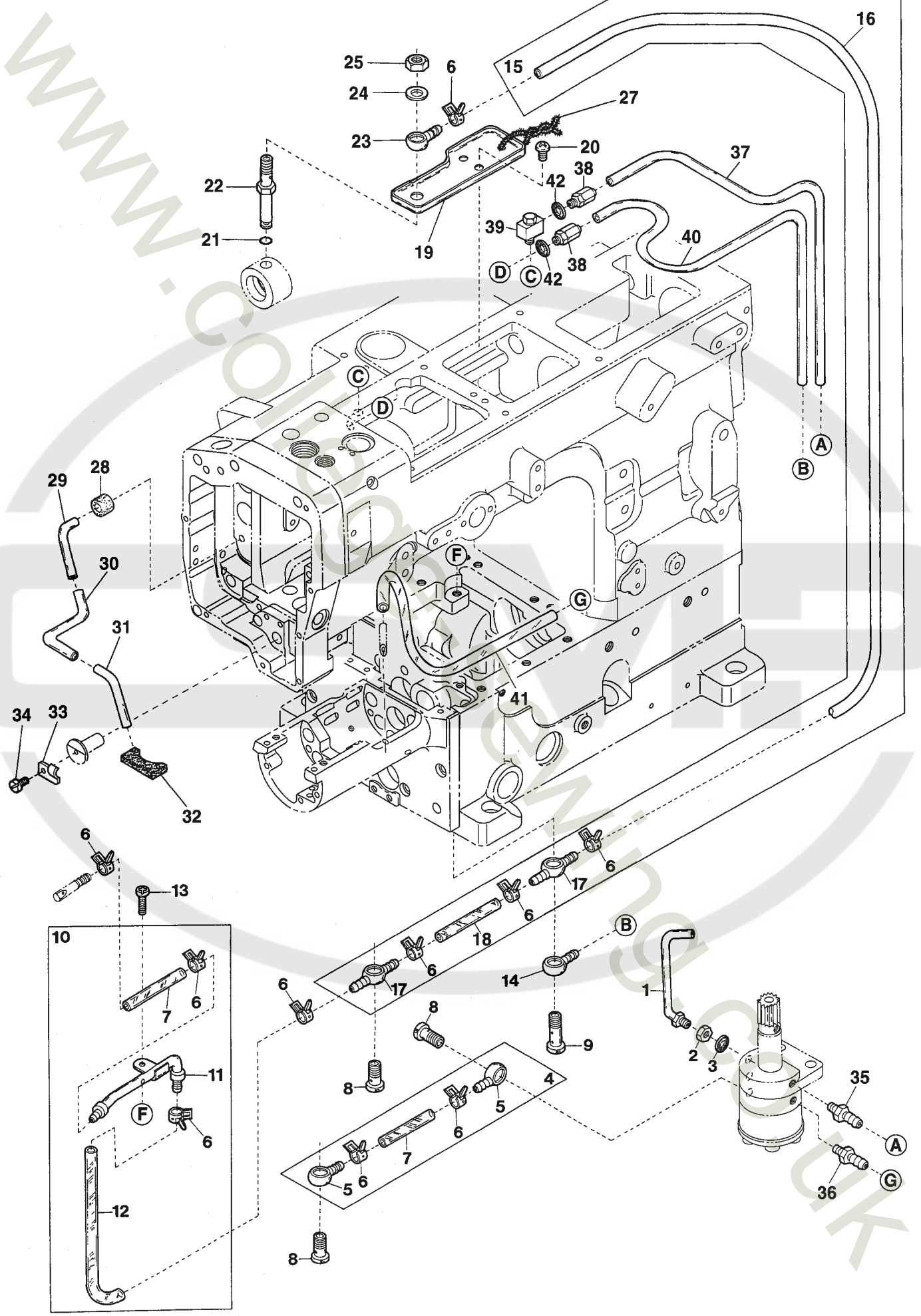

Ref.No	Parts No.	Description	品名	Amt. Req
1	3100349	Oil Nozzle for Worm Gear	給油パイプ	1
2	000419	Nut	ナット	1
3	000567	Seal	パッキン	1
4	3100356	Oil Tube(Short), Complete Set	給油パイプ(短)(組)	1
5	3100370	Oil Tube Joint, One Way	片口管継手	3
6	0031831	Oil Tube Clamp	緊束環	10
7	3100331	Oil Tube(4 × 6 × 31mm)	オイルパイプ	2
8	320008	Fitting Stud(Short)	環継手ボルト(短)	3
9	320009	Fitting Stud(Long)	環継手ボルト(長)	1
10	3100390	Oil Tube(Middle), Complete Set	給油パイプ(中)(組)	1
11	3100343	Lower Shaft Oiling Shower	下軸給油シャワ	1
12	3100334	Oil Tube(4 × 6 × 110mm)	オイルパイプ	1
13	110013	Screw(M4-0.7 × 8)	止ネジ	1
14	320001	Oil Tube Joint, One Way	片口管継手	1
15	3520011	Oil Tube(Long), Complete Set	給油パイプ(長)(組)	1
16	3270023	Oil Tube(4 × 6 × 530mm)	オイルパイプ	1
17	3100371	Oil Tube Joint, Two Way	両口管継手	2
18	3100332	Oil Tube(4 × 6 × 37mm)	オイルパイプ	1
19	3500412	Oil Receiver	油受ケ皿	1
20	110012	Screw(M4-0.7 × 5)	止ネジ	2
21	0032518	O-ring(P3)	Oリング	1
22	3500402	Oil Sight Top Nozzle	ノズル	1
23				
24	000425	Washer	ワッシャ	1
25	000234	Nut	ナット	2
26				
27	000463	Laced Wire(φ 3 × 260mm)	モール	1
28	0093617	Suction Pipe Bushing	吸入パイプブッシュ	1
29	3160152	Suction Pipe	吸入パイプ	1
30	3510067	Oil Tube(3 × 5 × 60mm)	オイルパイプ	1
31	3510065	Suction Pipe(Lower)	吸入パイプ(下)	1
32	3510068	Felt	フェルト	1
33	3160153	Suction Pipe Stay	吸入パイプ支エ	1
34	110038	Screw(M2.5-0.45 × 4.5)	止ネジ	1
35	0010018	Bamboo Joint(Φ 3.3-M5)	バンブ継手	1
36	0010017	Bamboo Joint(Φ 4.4-M5)	バンブ継手	1
37	3160151	Oil Tube(2.5 × 4 × 420mm)	オイルパイプ	1
38	0010258	Connector(Φ 2.5-M5)	コネクタ	2
39	0010019	Universal Elbow(M5)	ユニバーサルエルボ	1
40	3520010	Oil Tube(2.5 × 4 × 470mm)	オイルパイプ	1
41	3150159	Oil Tube(3 × 5 × 450mm)	オイルパイプ	1
42	000623	Seal	パッキン	1

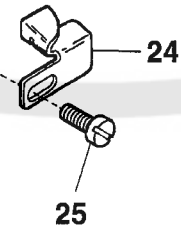
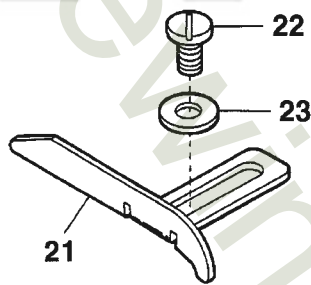
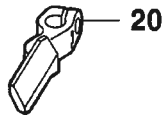
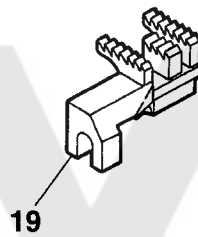
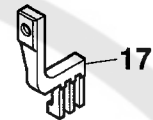
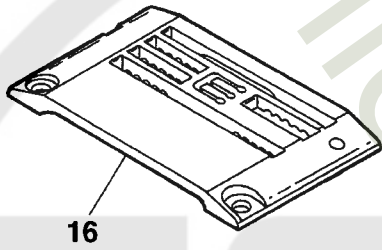
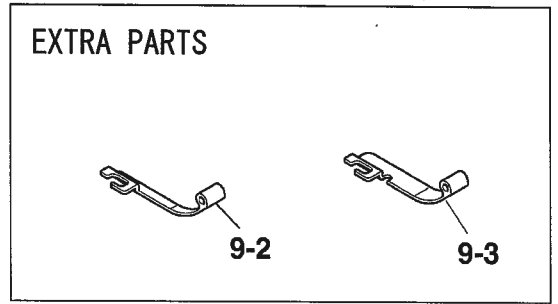
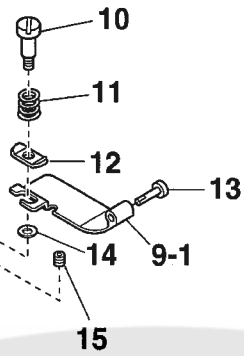
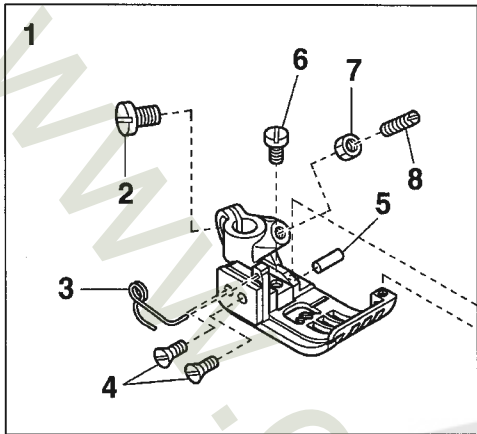

Ref.No	Parts No.	Description	品名	Amt. Req
1	3517003	Presser Foot, C. Set(56)	押エ(組)	1
2	110004	Screw(M3.5-0.6 × 8)	止ネジ	1
3	3107303	Presser Foot Spring(Left)	小押エバネ(左)	1
4	130016	Screw(M2.5-0.45 × 6)	止ネジ	2
5	3247022	Presser Foot Hinge Pin(56)	押エヒンジピン	1
6	110084	Screw(M3.5-0.5 × 4.2)	止ネジ	1
7	000327	Lock Nut	ロックナット	1
8	003302	Adjusting Screw(1/8-44 × 11)	止ネジ	1
9-1	3517039	Fabric Presser(Width 25.4mm)	布押エ	1
9-2	3517037	Fabric Presser(width 15.9mm)(Extra)	布押エ(特注品)	1
9-3	3517038	Fabric Presser(width 19mm)(Extra)	布押エ(特注品)	1
10	170058	Screw(M2-0.4 × 2.5)	止ネジ	1
11	3517031	Fabric Presser Spring	布押エバネ	1
12	2150112	Spring Holder	バネ受ケ	1
13	3517032	Fabric Presser Shaft	布押エ軸	1
14	300068	Washer	ワッシャ	1
15	160033	Screw(M2.5-0.45 × 3)	止ネジ	1
16	3158060	Stitch Plate(56S-1)	針板	1
17	3519010	Top Feed Dog	上送り	1
18				
19	3159040	Differential Feed Dog(56)	前送り	1
20	3159205	Needle Guard(Rear)	針受ケ(後)	1
21	3150165	Fabric Edge Guide(Right)	裾引キガイド(右)	1
22	007627	Screw(M4-0.7 × 6)	止ネジ	2
23	000533	Washer	ワッシャ	2
24	3155010	Fabric Edge Guide(Left)	裾引キガイド(左)	1
25	110007	Screw(M2.5-0.45 × 6)	止ネジ	1

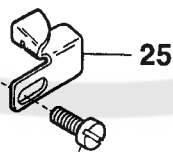
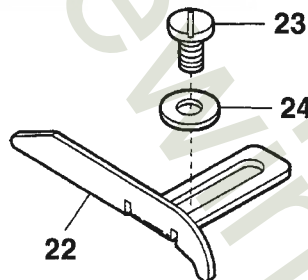
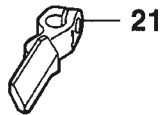
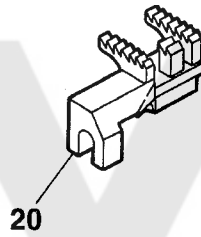
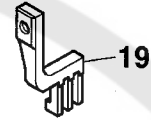
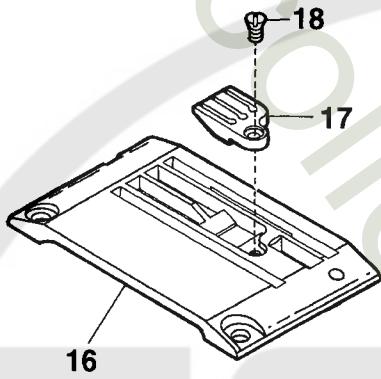
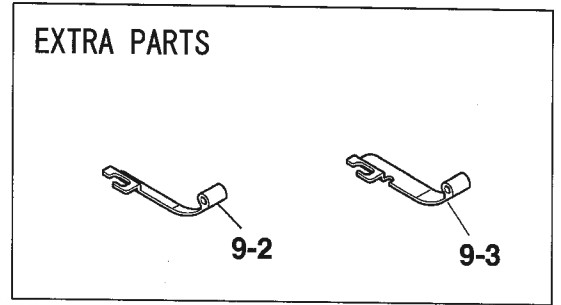
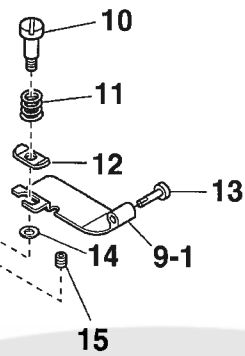
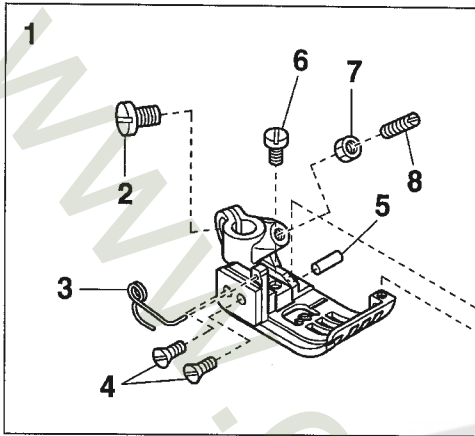

Ref.No	Parts No.	Description	品名	Amt. Req
1	3517003	Presser Foot, C. Set(56)	押工(組)	1
2	110004	Screw(M3.5-0.6 × 8)	止ネジ	1
3	3107303	Presser Foot Spring(Left)	小押エバネ(左)	1
4	130016	Screw(M2.5-0.45 × 6)	止ネジ	2
5	3247022	Presser Foot Hinge Pin(56)	押エヒンジピン	1
6	110084	Screw(M3.5-0.5 × 4.2)	止ネジ	1
7	000327	Lock Nut	ロックナット	1
8	003302	Adjusting Screw(1/8-44 × 11)	止ネジ	1
9-1	3517039	Fabric Presser(Width 25.4mm)	布押工	1
9-2	3517037	Fabric Presser(width 15.9mm)(Extra)	布押工(特注品)	1
9-3	3517038	Fabric Presser(width 19mm)(Extra)	布押工(特注品)	1
10	170058	Screw(M2-0.4 × 2.5)	止ネジ	1
11	3517031	Fabric Presser Spring	布押エバネ	1
12	2150112	Spring Holder	バネ受け	1
13	3517032	Fabric Presser Shaft	布押工軸	1
14	300068	Washer	ワッシャ	1
15	160033	Screw(M2.5-0.45 × 3)	止ネジ	1
16	3158150	Stitch Plate(56S8-1)	針板	1
17	3508155	Stitch Plate Tongue(56S8)	針板爪	1
18	004182	Screw(3/32-56 × 2.5)	止ネジ	1
19	3519010	Top Feed Dog	上送り	1
20	3159061	Differential Feed Dog(56)	前送り	1
21	3159205	Needle Guard(Rear)	針受け(後)	1
22	3150165	Fabric Edge Guide(Right)	裾引きガイド(右)	1
23	007627	Screw(M4-0.7 × 6)	止ネジ	2
24	000533	Washer	ワッシャ	2
25	3155010	Fabric Edge Guide(Left)	裾引きガイド(左)	1
26	110007	Screw(M2.5-0.45 × 6)	止ネジ	1

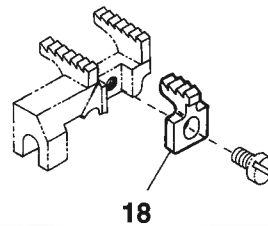
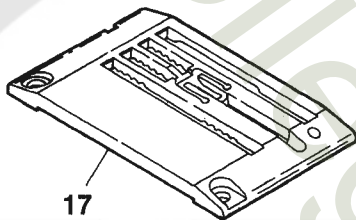
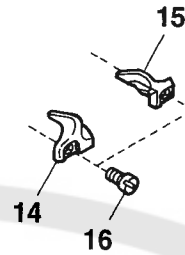
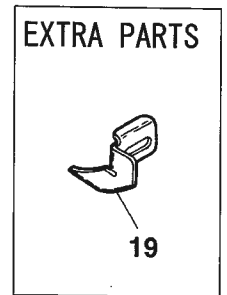
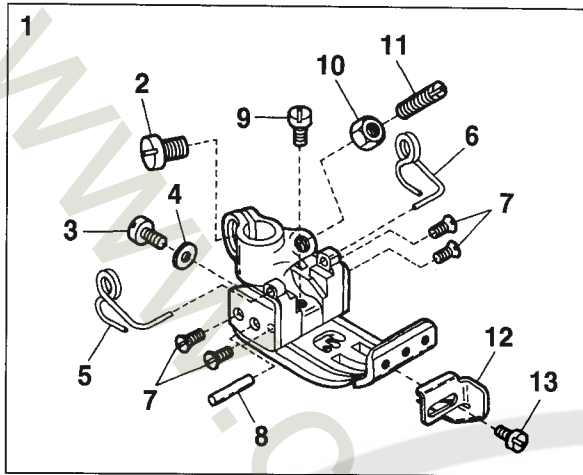

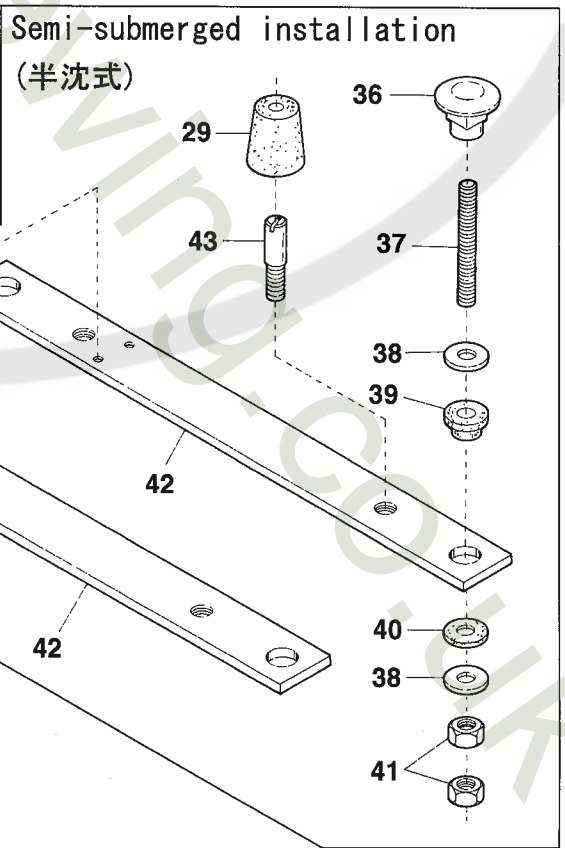
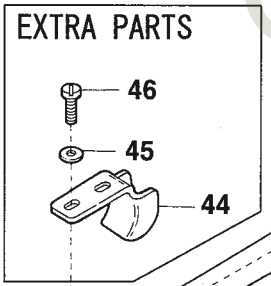
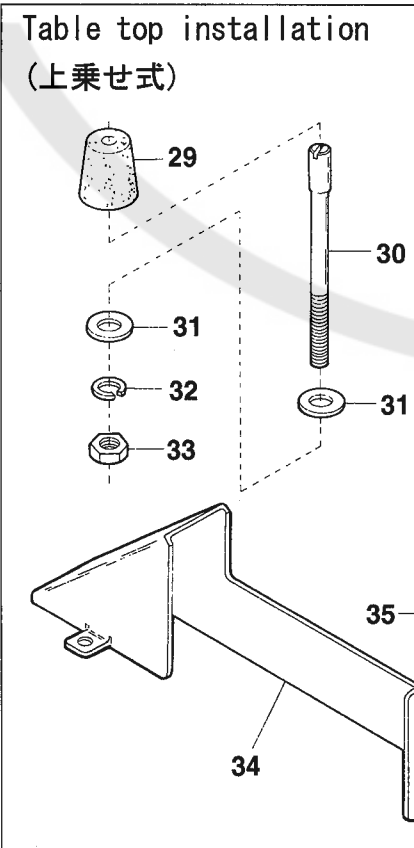
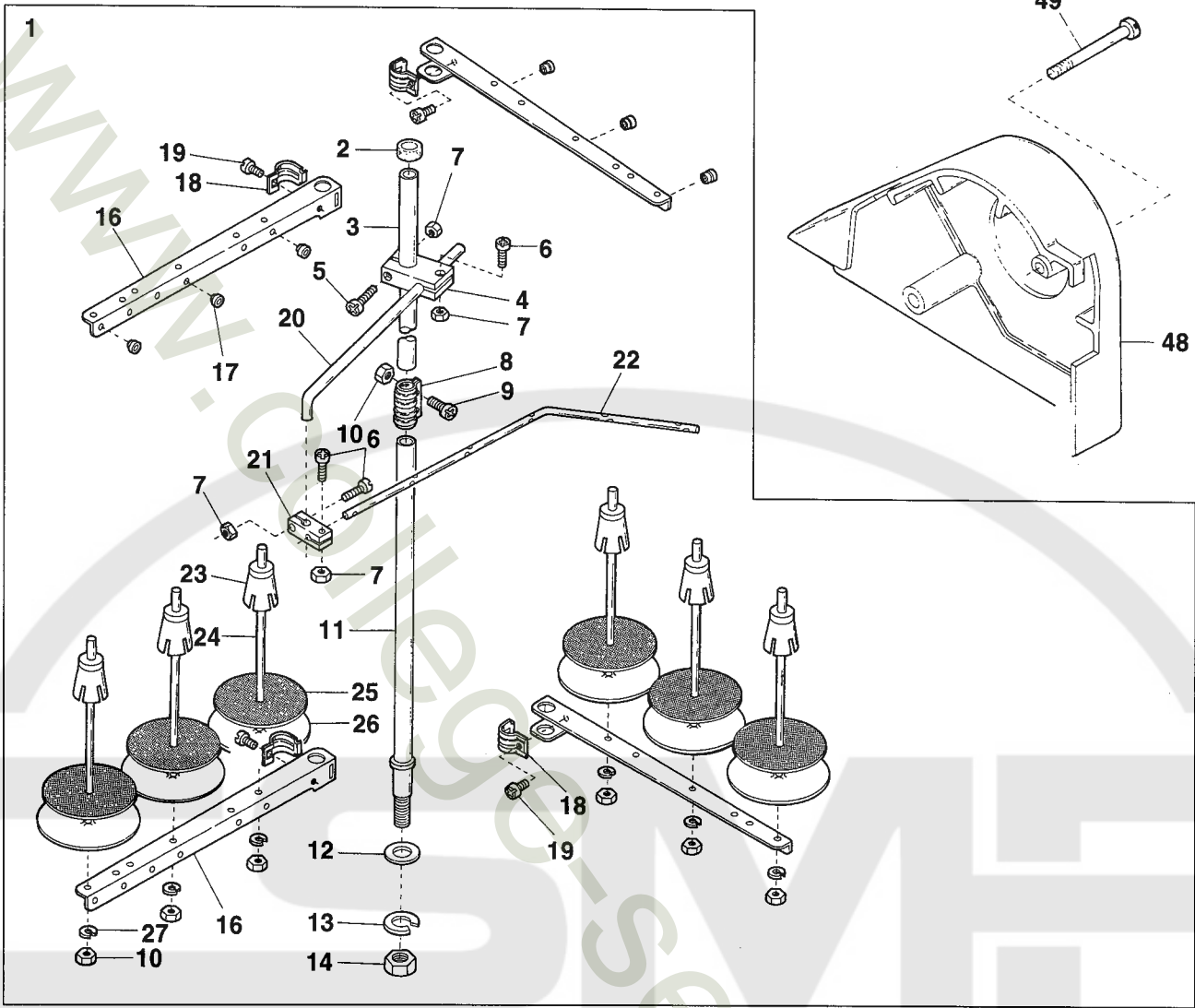

Ref.No	Parts No.	Description	品名	Amt. Req
1	3167029	Presser Foot, C. Set(56)	押エ(組)	1
2	110004	Screw(M3.5-0.6 × 8)	止ネジ	1
3	110054	Screw(M3-0.5 × 3.5)	止ネジ	1
4	000531	Washer	ワッシャ	1
5	3107303	Presser Foot Spring(Left)	小押エバネ(左)	1
6	3107304	Presser Foot Spring(Right)	押エバネ(右)	1
7	130016	Screw(M2.5-0.45 × 6)	止ネジ	4
8	3107306	Presser Foot Hinge Pin	押エヒンジピン	1
9	110084	Screw(M3.5-0.6 × 4.2)	止ネジ	1
10	000327	Lock Nut	ロックナット	1
11	260006	Adjusting Screw(1/8-44 × 9.5)	調節ネジ	1
12	3167040	Fabric Guide	布ガイド	1
13	110027	Screw(M2.5-0.45 × 3.5)	止ネジ	1
14	3520021	Fabric Guide(Left)	布ガイド(左)	1
15	3520020	Fabric Guide(Right)	布ガイド(右)	1
16	110007	Screw(M2.5-0.45 × 6)	止ネジ	2
17	3158082	Stitch Plate(56L-2)	針板	1
18	3159012	Differential Feed Dog(Middle)	中送り	1
19	3167041	Fabric Guide(Extra)	布ガイド(特注品)	1



Ref.No	Parts No.	Description	品名	Amt. Req
1	9620696	Thread Stand, C. Set(6 Spools Type)	糸立台(組)(6本糸用)	1
2	9620631	Column Cap	コラムキャップ	1
3	9620670	Column Pipe(Upper)	コラムパイプ(上)	1
4	9620689	Thread Guide Holder(Large)	ガイドホルダ(大)	1
5	911002	Screw(M4-0.7 × 20)	止ネジ	1
6	911001	Screw(M4-0.7 × 12)	止ネジ	3
7	910001	Nut	ナット	4
8	9620673	Column Pipe Connector	コラムパイプ継手	1
9	911006	Screw(M5-0.8 × 13)	止ネジ	2
10	910000	Nut	ナット	8
11	9620675	Column Pipe(Lower)	コラムパイプ(下)	1
12	930052	Washer	ワッシャ	1
13	930053	Spring Washer	スプリングワッシャ	1
14	910003	Nut	ナット	1
15				
16	9620703	Thread Hanger(3 Spool Type)	スレッドハンガ(3本糸用)	4
17	9620700	Thread Eyelet	アイレット	6
18	9620688	Thread Hanger Holder	スレッドハンガ抱キ	4
19	911060	Screw(M6-1 × 15)	止ネジ	4
20	9620691	Thread Guide Arm	ガイドアーム	1
21	9620690	Thread Guide Holder(Small)	ガイドホルダ(小)	1
22	9620666	Thread Guide(6 Spools Type)	スレッドガイド(6本糸用)	1
23	9620678	Spool Cushion	スプールクッション	6
24	9620679	Spool Pin	スプール軸	6
25	9620680	Spool Mat	スプールマット	6
26	9620681	Spool Seat Disc	受ケ皿	6
27	930055	Spring Washer	スプリングワッシャ	6
28				
29	0063009	Oil Reservoir Rubber Cushion	ゴム座	4
30	180008	Setting Screw(M6-1 × 63)	取付ケネジ	4
31	000528	Washer	ワッシャ	8
32	000667	Spring Washer	スプリングワッシャ	4
33	000011	Nut	ナット	4
34	3100036	Belt Cover(Lower)	ベルトカバー(下)	1
35	006905	Wood Screw(Φ 5.1 × 20)	木ネジ	3
36	000070	Hanging Nut	吊リナット	4
37	009858	Hanging Bolt(M8-1.25 × 75)	吊リボルト	4
38	000162	Washer	ワッシャ	8
39	0020064	Supporting Board Rubber Cushion	受ケ板ゴム座	4
40	0063010	SupportingBoardRubberCushion(Lower)	受ケ板ゴム座(下)	4
41	000016	Nut	ナット	8
42	3100008	Supporting Board	油受ケ板	2
43	180009	Setting Screw(M6-1 × 16)	取付ケネジ	4
44	3200242	Chain Guide	鎖ガイド	1
45	000541	Washer	ワッシャ	2
46	110009	Screw(M4-0.7 × 8)	止ネジ	2
47				
48	3150139 [3150133]	Belt Cover	ベルトカバー	1
49	110028	Screw(M6-1 × 46)	止ネジ	2

WARNING LABEL 警告ラベル

LABEL ラベル	Parts No. 品番	Description 品名
 <p>CAUTION</p> <p>Do not operate without eye guard and safety devices. Before threading, changing needle, cleaning etc. switch off main switch.</p>	390140	CAUTION IN OPERATION
 <p>注意</p> <p>動く部分でけがをする。 安全保護装置をつけて縫製作業をすること。 電源を切ってから、糸通し、ポビンや針の交換、掃除や調整をすること。</p>	390143	操作注意ラベル
 <p>高電圧警告 DANGER</p> <p>このカバーを開けるときは、電源スイッチを切った後、5分たってから開けること。</p> <p>To open this cover, turn off power supply and wait more than 5 minutes before opening.</p>	390144	DANGER : WARNING OF ELECTRIC SHOCK BY HIGH-VOLTAGE 感電注意ラベル
	390145	"Be sure to connect earth line". アースラベル
	390146	ROTATING-DIRECTION SYMBOL : CHECK CORRECT ROTATING DIRECTION 回転方向表示ラベル
 <p>ケガ注意 CAUTION</p>	390147	EYE GUARD : TAKE CARE NOT CAUSE INJURY TO EYES BELT COVER : DO NOT INSERT FINGERS ケガ注意ラベル
 <p>高温注意 CAUTION</p>	390148	CAUTION FOR HIGH TEMPERATURE : DO NOT TOUCH STEPPING MOTOR AND SOLENOID 高温注意ラベル

INDEX

VES2700-8

Page = 2

Parts No.	Page No.	Ref. No.	Weight(g)	Parts No.	Page No.	Ref. No.	Weight(g)	Parts No.	Page No.	Ref. No.	Weight(g)
0026099	12	18						110002	7	41	
0026413	12	15		0068011	1	4		110002	11	61	
				0068181	10	37		110004	10	16	
0030255	4	3		0068202	11	34		110004	18	23	
0030711	19	21		0068247	4	33		110004	21	2	
				0068249	4	35		110004	22	2	
0031111	4	7						110004	23	2	
0031831	20	6		0077179	13	13		110005	15	13	
				0077270	10	1		110007	21	25	
0032425	7	14						110007	22	26	
0032425	9	35		0080393	4	18		110007	23	16	
0032426	7	15						110008	7	8	
0032426	9	36		0085710	13	32		110009	4	17	
0032518	20	21						110009	6	14	
0032646	14	13		0090068	4	39		110009	8	32	
0032684	5	37		0090071	4	5		110009	10	40	
0032719	7	19		0090807	4	12		110009	14	5	
0032799	16	3		0090812	4	9		110009	16	16	
0032952	4	4		0090856	4	11		110009	24	46	
								110011	9	24	
0033024	12	20		0092305	8	5		110011	13	31	
0033024	17	9						110012	3	11	
				0093089	6	8		110012	4	19	
0034293	13	9		0093154	8	40		110012	19	25	
				0093186	9	28		110012	20	20	
0035813	4	46		0093212	9	17		110013	4	14	
				0093303	16	25		110013	7	10	
0036175	7	13		0093357	9	6		110013	16	48	
0036175	9	34		0093365	9	9		110013	19	29	
				0093515	7	39		110013	20	13	
0037108	4	45		0093528	4	22		110019	15	22	
				0093611	10	10		110021	10	53	
0060142	10	8		0093617	20	28		110022	17	18	
				0093864	1	9		110023	11	25	
0063009	24	29		0093864	2	10		110023	12	37	
0063010	24	40						110023	19	15	
0063044	9	3		0094201	3	10		110027	19	13	
0063051	14	18		0094390	10	62		110027	23	13	
0063053	14	20						110028	24	49	
0063055	5	7		0095027	13	21		110031	14	26	
0063056	14	21		0095334	10	63		110032	2	30	
0063057	14	22						110035	3	9	
0063074	4	43		100002	15	26		110035	6	25	
0063515	10	60		100003	14	9		110035	9	5	
				100005	16	32		110035	10	5	
0065275	2	18		100007	11	41		110035	18	24	
0065372	10	3						110036	1	19	
0065389	15	30		110001	10	7		110036	6	32	

INDEX

VES2700-8

Page = 3

Parts No.	Page No.	Ref. No.	Weight(g)	Parts No.	Page No.	Ref. No.	Weight(g)	Parts No.	Page No.	Ref. No.	Weight(g)
110038	18	28		120016	1	31		160004	6	17	
110038	20	34		120018	17	8		160004	8	39	
110039	15	4		120018	18	18		160005	6	2	
110041	2	27		120027	1	7		160005	8	3	
110041	7	6		120047	17	6		160006	11	32	
110045	1	2		120047	18	12		160007	6	3	
110045	2	15		120048	6	37		160007	7	26	
110045	19	2		120049	11	5		160007	8	4	
110048	1	13		120049	12	41		160007	11	68	
110048	3	12						160007	12	26	
110054	7	43		130002	9	19		160007	14	17	
110054	10	14		130002	11	7		160007	16	2	
110054	13	15		130003	2	5		160009	6	7	
110054	19	9		130003	4	41		160015	7	27	
110054	23	3		130004	16	29		160021	6	6	
110060	1	14		130011	16	47		160021	13	27	
110060	6	30		130016	10	19		160023	8	29	
110067	8	42		130016	21	4		160024	15	8	
110076	5	48		130016	22	4		160029	9	25	
110079	2	21		130016	23	7		160029	15	45	
110084	10	21						160030	12	23	
110084	21	6		140004	11	20		160033	21	15	
110084	22	6		140004	12	33		160033	22	15	
110084	23	9						160040	15	2	
110091	2	24		150001	10	12		160041	8	43	
110092	18	5									
110094	13	34		160000	6	28		170001	3	7	
110112	9	11		160000	11	21		170009	10	56	
110115	11	62		160000	12	30		170010	5	43	
110135	8	35		160000	17	16		170010	7	37	
				160000	18	2		170010	13	18	
120001	3	2		160001	3	3		170038	10	55	
120001	8	19		160001	6	34		170041	10	31	
120001	10	58		160001	10	34		170058	21	10	
120001	11	72		160001	11	35		170058	22	10	
120006	10	51		160001	12	13					
120007	18	14		160001	13	4		180005	3	5	
120008	17	22		160001	15	16		180008	24	30	
120009	16	18		160001	16	45		180009	24	43	
120010	10	45		160001	19	22		180012	13	12	
120011	15	40		160002	16	4		180033	11	39	
120011	19	23		160003	7	23					
120013	7	2		160003	8	17		190004	16	31	
120013	8	21		160003	11	3		190005	7	4	
120013	11	13		160003	12	4		190077	11	64	
120013	12	7		160003	13	20		190102	4	23	
120013	14	11		160003	14	3					
120015	8	25		160003	15	29		260006	10	23	

INDEX

VES2700-8

Page = 4

Parts No.	Page No.	Ref. No.	Weight(g)	Parts No.	Page No.	Ref. No.	Weight(g)	Parts No.	Page No.	Ref. No.	Weight(g)
260006	23	11						3100087	7	11	
				350009	4	32		3100092	5	29	
290029	4	8						3100093	5	30	
				910000	24	10		3100100	5	6	
300000	11	10		910001	24	7		3100103	16	23	
300000	15	23		910003	24	14		3100104	16	24	
300005	10	44						3100110	10	9	
300006	14	6		911001	24	6		3100113	2	20	
300006	16	15		911002	24	5		3100121	6	16	
300048	18	22		911006	24	9		3100122	6	12	
300068	21	14		911060	24	19		3100123	6	15	
300068	22	14						3100127	6	13	
300100	3	6		930052	24	12		3100129	8	7	
300100	5	44		930053	24	13		3100131	6	10	
300100	7	38		930055	24	27		3100140	15	32	
300500	15	5						3100141	15	35	
				2049401	1	32		3100142	15	37	
310035	11	73						3100143	15	39	
310035	17	3		2100034	5	32		3100144	15	43	
310040	8	13		2100137	11	14		3100145	15	42	
310047	19	19		2100137	12	3		3100146	15	41	
310054	19	18		2100161	7	22		3100147	15	28	
310068	11	23		2100176	11	52		3100149	15	31	
310068	12	35		2100194	10	48		3100150	15	27	
310077	19	11		2100218	8	22		3100151	15	24	
310078	17	26		2100218	14	27		3100152	15	10	
310094	14	19		2100259	13	8		3100153	15	20	
310099	8	41		2100267	10	33		3100155	15	21	
310106	5	2		2100288	11	29		3100156	15	9	
310132	8	36		2100620	17	15		3100157	15	11	
								3100158	15	12	
320001	20	14		2110361	10	46		3100159	15	15	
320008	20	8						3100160	15	17	
320009	20	9		2120082	12	14		3100161	15	19	
				2120083	12	19		3100189	16	8	
330000	9	22						3100190	16	7	
330002	15	18		2150112	21	12		3100191	16	10	
330007	7	29		2150112	22	12		3100192	16	6	
330009	17	4						3100193	16	11	
330009	19	17		3100004	1	26		3100194	16	12	
				3100005	1	27		3100195	16	13	
340000	1	30		3100006	5	28		3100196	16	14	
340001	15	25		3100008	24	42		3100197	16	17	
340003	10	49		3100020	2	3		3100199	16	19	
340003	16	22		3100036	24	34		3100200	16	21	
340034	1	23		3100060	19	1		3100202	16	20	
340035	2	29		3100061	19	3		3100203	16	39	
340036	2	28		3100081	4	42		3100204	16	43	

INDEX

VES2700-8

Page = 5

Parts No.	Page No.	Ref. No.	Weight(g)	Parts No.	Page No.	Ref. No.	Weight(g)	Parts No.	Page No.	Ref. No.	Weight(g)
3100205	15	6		3120068	7	25		3150066	18	15	
3100205	16	42		3120070	6	4		3150067	18	13	
3100206	16	46		3120072	7	17		3150068	16	26	
3100207	1	10		3120073	7	5		3150069	6	11	
3100207	12	28		3120074	7	7		3150072	6	23	
3100207	16	44		3120143	7	42		3150073	6	5	
3100208	16	40						3150074	6	1	
3100210	16	27		3150004	1	15		3150077	19	12	
3100211	16	38		3150005	7	1		3150078	19	14	
3100217	16	1		3150007	5	15		3150080	6	22	
3100272	5	46		3150008	5	16		3150081	6	24	
3100275	8	10		3150009	5	20		3150082	6	26	
3100283	8	11		3150010	5	21		3150083	6	27	
3100305	14	16		3150011	5	25		3150086	6	33	
3100307	14	24		3150012	5	19		3150088	6	35	
3100309	14	7		3150013	5	18		3150089	6	29	
3100310	10	11		3150014	5	23		3150095	2	22	
3100329	19	5		3150015	5	24		3150096	2	25	
3100330	19	26		3150016	5	22		3150097	2	23	
3100331	20	7		3150017	5	27		3150098	18	25	
3100332	20	18		3150018	5	26		3150099	1	20	
3100334	20	12		3150019	5	17		3150100	1	21	
3100338	9	30		3150020	5	31		3150101	1	22	
3100343	20	11		3150022	17	11		3150102	2	8	
3100345	19	4		3150024	17	12		3150103	2	1	
3100349	20	1		3150025	17	14		3150105	2	6	
3100355	15	34		3150027	17	17		3150106	2	12	
3100356	20	4		3150028	17	19		3150109	4	15	
3100370	20	5		3150030	17	5		3150111	3	13	
3100371	20	17		3150031	17	10		3150114	3	4	
3100384	4	29		3150032	17	7		3150116	3	1	
3100386	4	30		3150034	17	1		3150119	1	24	
3100390	20	10		3150040	16	5		3150120	7	32	
3100533	10	57		3150041	17	24		3150122	7	9	
				3150043	17	25		3150123	2	31	
3107303	10	17		3150045	17	23		3150129	2	11	
3107303	21	3		3150047	17	21		3150134	7	30	
3107303	22	3		3150048	17	20		3150135	7	34	
3107303	23	5		3150051	18	1		3150136	7	36	
3107304	10	18		3150052	18	3		3150138	19	6	
3107304	23	6		3150053	18	4		3150139	24	48	
3107306	10	20		3150054	18	6		3150141	1	18	
3107306	23	8		3150055	18	21		3150142	19	8	
				3150056	18	20		3150143	19	20	
3109300	15	1		3150057	18	19		3150153	7	28	
				3150059	18	26		3150154	19	16	
3120060	7	21		3150060	15	7		3150155	19	24	
3120061	7	24		3150062	18	10		3150156	19	7	

INDEX

VES2700-8

Page = 6

Parts No.	Page No.	Ref. No.	Weight(g)	Parts No.	Page No.	Ref. No.	Weight(g)	Parts No.	Page No.	Ref. No.	Weight(g)
3150157	16	28		3160050	12	40		3160191	9	32	
3150159	20	41		3160051	12	9					
3150163	1	17		3160052	12	43		3167029	23	1	
3150165	21	21		3160054	12	42		3167040	23	12	
3150165	22	22		3160056	12	5		3167041	23	19	
3150170	15	3		3160057	12	6		3167054	10	15	
3150181	2	26		3160058	12	8		3167057	10	24	
3150183	6	20		3160060	12	44		3167058	10	26	
3150184	18	7		3160061	12	16					
3150186	18	9		3160062	12	17		3180035	2	4	
3150187	18	8		3160063	12	21		3180070	8	30	
3150189	19	27		3160064	12	12		3180071	4	28	
				3160065	12	29		3180072	4	31	
3155010	21	24		3160066	12	31		3180073	4	40	
3155010	22	25		3160070	12	25		3180075	8	31	
				3160071	12	24		3180076	4	16	
3158060	21	16		3160073	13	19					
3158082	23	17		3160074	13	23		3200086	11	38	
3158094	9	10		3160076	13	24		3200112	9	16	
3158150	22	16		3160077	7	45		3200242	24	44	
				3160077	13	22		3204021	5	5	
3159012	23	18		3160080	13	26					
3159019	18	27		3160081	13	30		3240015	9	26	
3159037	18	17		3160082	13	28		3240016	9	27	
3159040	21	19		3160084	13	16		3240026	10	6	
3159043	18	11		3160085	13	1		3240086	13	14	
3159061	22	20		3160086	13	3		3240087	13	6	
3159200	6	36		3160088	13	7		3240091	13	5	
3159201	6	31		3160090	10	29					
3159205	21	20		3160091	10	39		3247022	21	5	
3159205	22	21		3160092	11	36		3247022	22	5	
				3160098	11	24					
3160008	2	13		3160098	12	36		3260010	6	9	
3160009	2	14		3160103	11	37		3260011	8	9	
3160022	5	33		3160104	11	33					
3160023	5	34		3160109	11	71		3270015	9	1	
3160024	5	35		3160114	11	55		3270023	20	16	
3160025	5	38		3160116	11	59					
3160026	5	39		3160120	11	54		3500012	2	16	
3160027	5	36		3160124	11	46		3500041	5	13	
3160034	11	2		3160138	14	12		3500044	5	9	
3160036	11	12		3160151	20	37		3500045	5	10	
3160037	11	16		3160152	20	29		3500046	5	14	
3160038	11	18		3160153	20	33		3500047	5	11	
3160038	12	10		3160158	5	4		3500048	5	12	
3160039	11	17		3160163	10	4		3500050	5	8	
3160039	12	11		3160173	12	1		3500051	8	1	
3160049	12	39		3160190	9	31		3500054	8	6	

INDEX

VES2700-8

Page = 7

Parts No.	Page No.	Ref. No.	Weight(g)	Parts No.	Page No.	Ref. No.	Weight(g)	Parts No.	Page No.	Ref. No.	Weight(g)
3500062	8	37		3510018	11	4		3517038	22	9-3	
3500064	8	38		3510020	11	27		3517039	21	9-1	
3500065	8	26		3510021	11	28		3517039	22	9-1	
3500066	8	20		3510022	11	30					
3500081	14	1		3510023	12	32		3519010	21	17	
3500082	14	2		3510024	11	31		3519010	22	19	
3500084	14	4		3510025	8	14		3519012	11	65	
3500086	14	10		3510027	11	8					
3500091	9	15		3510028	11	9		3520010	20	40	
3500096	5	50		3510029	11	6		3520011	20	15	
3500097	14	28		3510030	11	47		3520012	9	12	
3500100	9	4		3510031	11	48		3520013	9	14	
3500201	1	1		3510032	11	49		3520020	23	15	
3500284	4	25		3510033	11	53		3520021	23	14	
3500285	4	27		3510034	11	50					
3500286	4	13		3510035	11	63		4109403	3	14	
3500287	4	10		3510037	11	26					
3500291	10	42		3510037	12	38		9620631	24	2	
3500292	10	59		3510038	11	19		9620666	24	22	
3500293	10	35		3510039	11	22		9620670	24	3	
3500294	10	38		3510039	12	34		9620673	24	8	
3500295	10	50		3510040	11	56		9620675	24	11	
3500299	10	54		3510041	11	58		9620678	24	23	
3500300	10	32		3510043	11	69		9620679	24	24	
3500305	10	47		3510044	11	70		9620680	24	25	
3500309	5	1		3510045	8	8		9620681	24	26	
3500402	20	22		3510050	5	41		9620688	24	18	
3500412	20	19		3510051	5	42		9620689	24	4	
3500430	1	3		3510052	5	47		9620690	24	21	
3500442	8	34		3510055	13	33		9620691	24	20	
3500444	8	15		3510057	11	60		9620696	24	1	
3500445	8	16		3510059	11	43		9620700	24	17	
3500446	8	18		3510060	11	44		9620703	24	16	
3500448	8	12		3510062	11	42					
3500489	4	20		3510063	10	30					
3500492	8	27		3510065	20	31					
3500615	9	23		3510067	20	30					
3500616	9	20		3510068	20	32					
3500617	9	18									
				3517003	21	1					
3508155	22	17		3517003	22	1					
				3517031	21	11					
3509320	14	25		3517031	22	11					
				3517032	21	13					
3510008	1	6		3517032	22	13					
3510011	1	11		3517037	21	9-2					
3510012	1	12		3517037	22	9-2					
3510017	11	1		3517038	21	9-3					

