

# **WOLF**® PARTS AND SERVICE MANUAL **HOT KNIFE II**



- Temperature ranges – 650° to 750° F.
- Overall length only 10" (254 mm).
- Net weight only 1lb 2ozs (.511kgs).
- Blade diameter 3" (76.20mm).
- Comes standard with automatic timer and safety stand (not shown).
- Available in 110V or 220V, one phase, 50 or 60 cycles.

## **WARNING**

This machine uses extremely high heat (650° to 750°F) for proper operation, always exercise care when handling or using it. Disconnect electrical connector when machine is unattended, when NOT in use, performing repairs, maintenance or cleaning. Remove all flammable materials and liquids from the work area. For operator safety the use of heat resistant gloves are recommended.

## **SERVICE INSTRUCTIONS**

1. Allow unit to heat 10 minutes before using.
2. Never cut on an abrasive surface. A heat resistant material such as Silicon covered fiberglass cloth is the optimal cutting surface.
3. Do not use abrasives to clean wheel. Clean wheel when hot by rubbing on cotton cloth.
4. Order all parts by Part Number shown and provide voltage.

**WOLF**®  
*1st/Since 1888*

### **THE WOLF MACHINE COMPANY**

5570 Creek Road • Cincinnati, OH 45242 • USA

Phone: 513-791-5194 • FAX 513-791-0925

TOLL FREE 1-800-543-WOLF

e-mail: info@wolfmachine.com • Web Site: www.wolfmachine.com

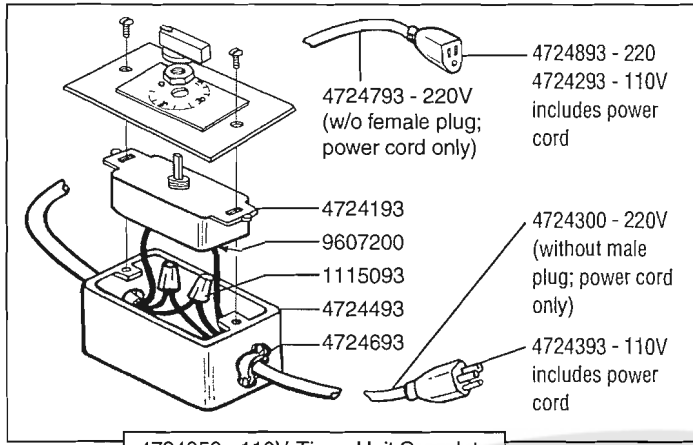

4724050 - 110V, Timer Unit Complete  
4724550 - 220V, Timer Unit Complete

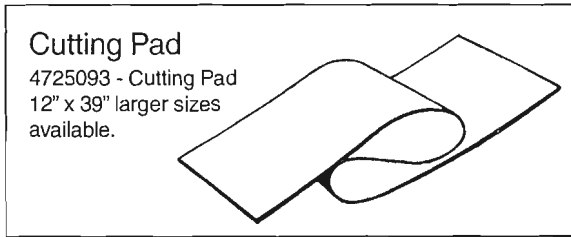

### Cutting Pad

4725093 - Cutting Pad  
12" x 39" larger sizes available.

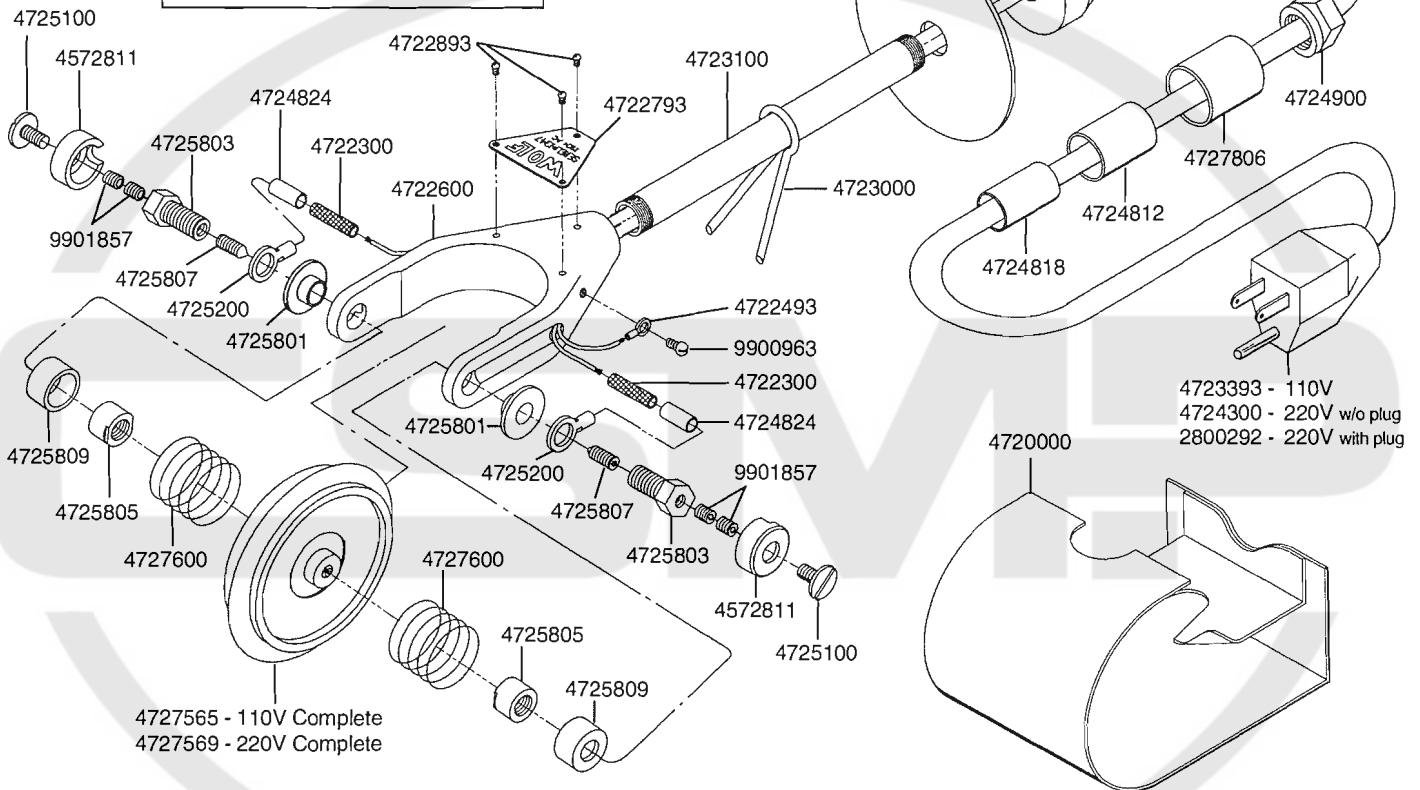

4727565 - 110V Complete  
4727569 - 220V Complete

4723393 - 110V  
4724300 - 220V w/o plug  
2800292 - 220V with plug

Part No.	Description	Quantity used if more than 1
1115093	Wire Connector	
4572811	Button Cover	2
4720000	Stand	
4722300	Insulator Sleeve	2
4722493	Terminal #2	
4722600	Yoke, Hot Knife	
4722793	Label	
4722893	Drive Screw #2	3
4723000	Rest	
4723100	Handle Tube	
4723200	Wood Handle	
4723393	Power Cord - 110V	
4724050	Timer Unit Complete - 110V	
4724193	Timer	
4724293	Power Cord with Female Plug - 110V	
4724300	Power Cord without Male Plug - 220V	
4724393	Power Cord with Male Plug - 110V	
4724493	Timer Box	
4724550	Timer unit Complete - 220V	
4724693	3/4" Connector	
4724793	Power Cord without Female Plug - 220V	

Part No.	Description	Quantity used if more than 1
4724812	1/2" Shrinkable Tube	
4724818	7/16" Shrinkable Tube	
4724824	1/4" Shrinkable Tube	2
4724893	Female Plug - 220V	
4724900	7/16-20 Nyloc Nut	
4725093	Cutting Pad 12" x 39" (larger sizes available)	
4725100	Nylon Screw	2
4725200	Terminal #1	2
4725801	Yoke Bushing	2
4725803	Wheel Adjust Bolt	2
4725805	Wheel Adjust Bolt	2
4725807	Wheel Adjust Pivot	2
4725809	Wheel Adjust Cover	2
4727565	110V - Wheel Assembly	
4727569	220V - Wheel Assembly	
4727600	Grounding Spring	2
4727700	Finger Guard	
4727806	3/4" Shrinkable Tube	
9607200	Spade Fork Terminal	2
9900963	Binder head Screw	
9901857	Set Screw	4