



# Union Special

INDUSTRIAL SEWING EQUIPMENT

CATALOG NO. T129R  
SUPPLEMENT TO CATALOG NO. 129M  
STYLE OF MACHINE

Advanced High Speed Two Needle Flat Bed Machines, Independent Row, High Throw, Needle Bearing Needle Bar Drive, Light Weight Presser Bar and Needle Bar Driving Mechanism, Single Reservoir Enclosed Positive Automatic Lubricating System. Filtered Oil Return Pumps for Head and Base, Needle Bearings and Bronze Bearings for Feed Bar and Feed Rocker Shafts Greased and Sealed, Lateral Looper Travel, Large Handwheel and Improved Belt Guard, Prepared for Use with Knee Press for Foot Lifter, Equipped with Rotary Thread Tensions, Work Space to Right of Needle Bar 8 1/4 Inches.

56500 R For attaching risers to dungarees, piecing sleeves on denim jackets, and for attaching overall bibs and for similar operations on medium heavy to heavy weight materials. Left needle in front. Seam Spec. 401-LSc-2. Type 128 GS needle. Standard gauge No. 18. Maximum recommended speed 6000 R.P.M., depending on material and operation.

## APPLICATION OF CATALOG

This catalog is a supplement to Catalog No. 129 M and should be used in conjunction therewith. Only the parts found on Style 56500 R, but not on Style 56500 J are illustrated. On the back is an illustration identifying the parts by reference number and on the bottom of the page, the part numbers and descriptions identifies the part. Any part that is a component of another part is indicated by indenting its description under the description of the assembly or base part. Always use the part number in the second column, never use the reference number in the first column when ordering repair parts.

## IDENTIFYING PARTS

Where construction permits, each Union Special part is stamped with its catalog part number. A part too small for its complete catalog stamping is identified by a letter symbol which distinguishes it from another part similar in appearance.

Each part number represents the same part, regardless of the catalog in which it appears.

**IMPORTANT!** ON ALL ORDERS, PLEASE INCLUDE PART NUMBER AND STYLE OF MACHINE FOR WHICH PART IS ORDERED.

## TERMS

Prices are strictly net cash and are subject to change without notice. All shipments are forwarded f.o.b. shipping point. Parcel Post shipments are insured unless otherwise directed. A charge is made to cover the postage and insurance.

## NEEDLES

Needle Type 128 GS is recommended for Style 56500 R. The description and sizes available are as follows:

128 GS Round shank, round point, short, double groove, struck groove, ball eye, spotted, undersize eye and grooves 27% of size of needle, chromium plated, and is available in sizes 036, 040, 044, 049, 054.

## ASSEMBLING AND ADJUSTING SEWING PARTS

All of the adjusting instructions for Style 56500 J are applicable for Style 56500 R except as follows:

Set the needle thread frame eyelet 3/4 inch above the mounting screw, and the needle thread tension at 3 ounces. Set the folder so that the stitches are in the center of the seam. The material must be free through the folder to prevent scuffing by the feed dog.

The parts illustrated and described below, represent the parts that are used on Style 56500 R, but not used on Style 56500 J.

Use Catalog No. 129 M (Style 56500 J) for all parts not illustrated or described in this catalog.

Reference numbers that are inside a bracket or box on the pictureplate and have indented descriptions, indicate they are component parts of a complete part or assembly.

<u>Ref. No.</u>	<u>Part No.</u>	<u>Description</u>	<u>Amt. Req.</u>
1	51505 BR-18	Feed Dog, 12 teeth per inch -----	1
2	51524 BR-18	Throat Plate -----	1
3	51520 BR-18	Presser Foot -----	1
4	51530 BR-18	Bottom, front section -----	1
5	22799 C	Hinge Screw, for bottom, front section-----	1
6	35730 AC	Hinge Section -----	1
7	22799 G	Hinge Screw, for bottom, rear section-----	1
8	51530 J	Bottom, rear section -----	1
9	35730 AD	Shank -----	1
10	91	Screw -----	1
11	73 A	Screw, for spring-----	1
12	35730 AE	Spring -----	1
13	29476 LK-096	Feed Lift Eccentric Assembly -----	1
	29476 LK-072	Looper Avoid Eccentric Assembly -----	1
14	56306-096	Feed Lift Eccentric, .096 inch throw -----	1
	56306-072	Looper Avoid Eccentric, .072 inch throw---	1
15	22894 AA	Spot Screw -----	1
16	77	Screw, for link pin-----	1

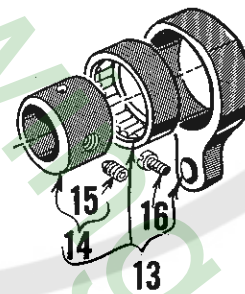
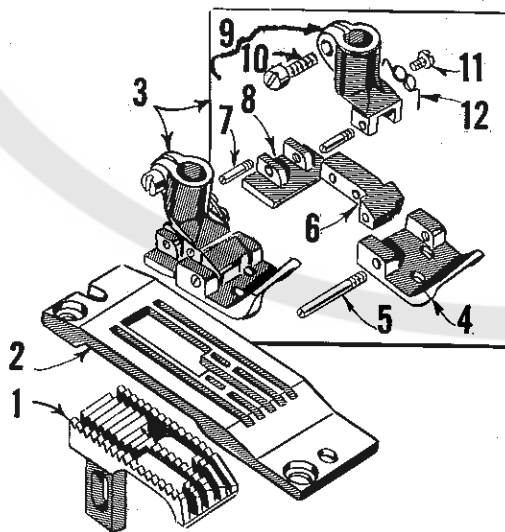

PRINTED 1996 IN USA

INFORMATION SUBJECT TO CHANGE WITHOUT NOTICE

© UNION SPECIAL CORPORATION ALL RIGHTS RESERVED IN ALL COUNTRIES.