

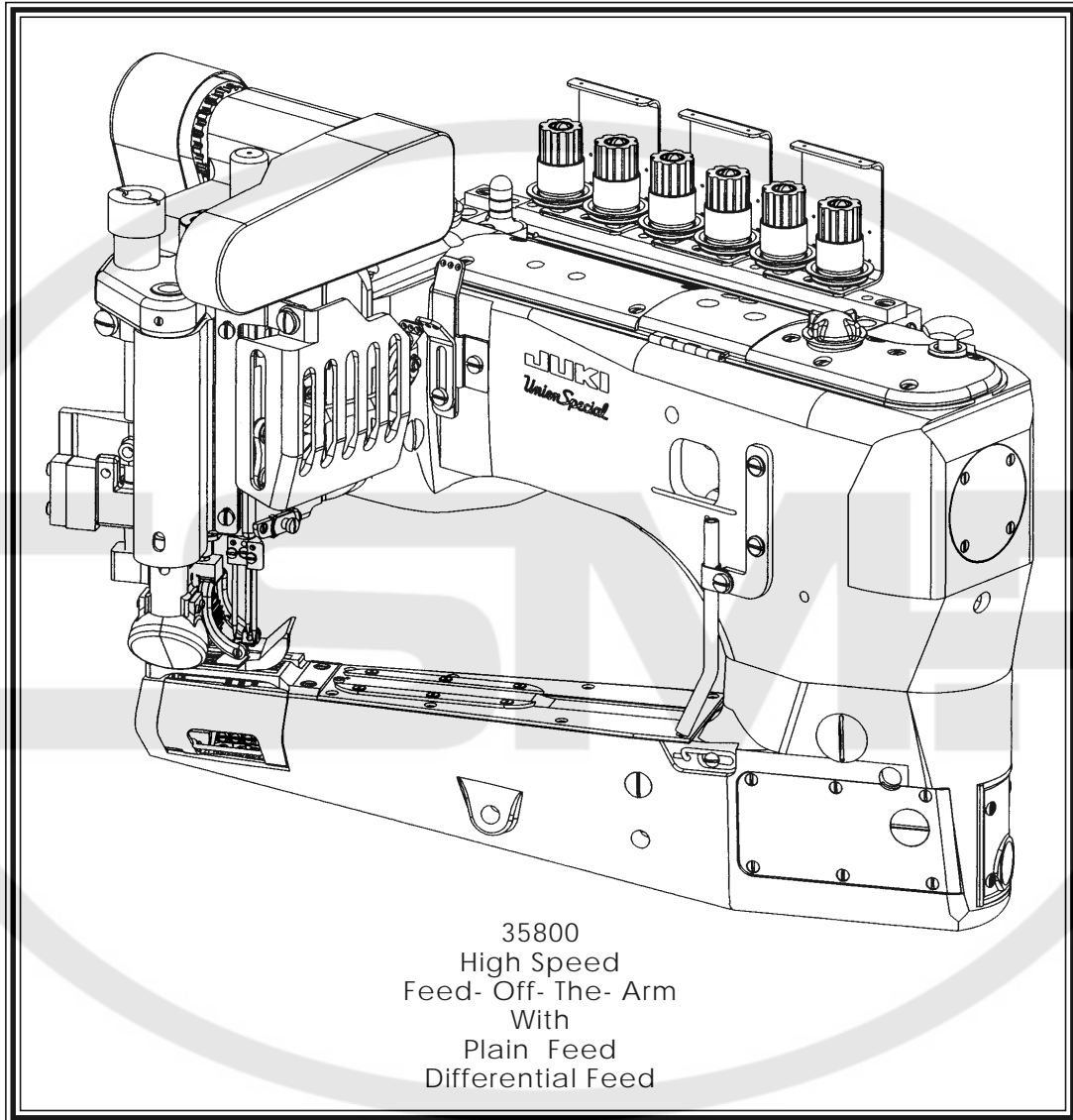

JUKI

Union Special

ADJUSTING INSTRUCTIONS / ILLUSTRATED PARTS LIST



MANUAL NO. PT9640

STYLES

3580BLW
3580BLWP
3580BQW
3580BQWP
3580BRW
3580BRWH
3580BRWP

3580BRWL
3580BRWPL
3580BWDN
3580BWDR
3580BWW
3580BWWP
3580BWWL
3580BWWPL

Manual No. PT9640 Adjusting Instructions & Illustrated Parts List for 35800 Series Machines

Forth Edition Copyright 2002
By
Union Special Corporation Rights Reserved In All Countries
Printed in U.S.A. October 2002

PREFACE

This parts manual has been prepared to assist you in locating individual parts or assemblies on 35800 Series machines.

It is the desire of Union Special that each machine run at its optimum performance. Parts listed in this manual are designed specifically for your machine and are manufactured with utmost precision to assure long lasting service.

This manual has been comprised on the basis of available information. Changes in design and/or improvements may incorporate a slight modification of configuration in illustrations or part numbers.

On the following pages are illustrations and terminology used in describing the parts used on 35800 Series machines.



CONTENTS

SAFETY RULES	4
IDENTIFICATION OF MACHINES	5
CLASS DESCRIPTION	5
STYLE OF MACHINES	5
STYLE OF MACHINES (CONT.)	6
ILLUSTRATIONS	6
IDENTIFYING PARTS	6
TERMS	6
THREADING & OILING FOR PLAIN FEED	7
THREADING & OILING FOR DIFFERENTIAL FEED	8
NEEDLES	9
LUBRICATION	9
THREADING	9
ADJUSTING INSTRUCTIONS	9
TORQUE REQUIREMENTS	9
SYNCHRONIZING NEEDLE AND LOOPER MOTIONS	10
TIGHTENING NEEDLE HEAD	11
ALIGNING NEEDLES IN THROAT PLATE SLOTS	11
CENTERING THE CYLINDER	11
SETTING THE LOOPER	11
SETTING THE LOOPER AVOID PLAIN FEED	12
SETTING HEIGHT OF NEEDLE BAR	12
SETTING THE FEED DOGS FOR PLAIN FEED	12
SETTING THE FEED DOGS FOR DIFFERENTIAL FEED	12
SETTING THE FEED DOGS FOR DIFFERENTIAL FEED (CONT.)	13
CHANGING STITCH LENGTH	13
SETTING REAR NEEDLE GUARD	13
PRESSER FOOT AND PRESSER BAR ADJUSTMENT	14
UPPER FEED ROLLER ADJUSTMENT	14
UPPER FEED ROLLER ADJUSTMENT (CONT.)	15
THREAD TENSION AND RELEASE	15
DIFFERENTIAL CONTROL	15
SETTING NEEDLE THREAD TAKE-UP AND FRAME EYELET	16
LOOPER THREAD TAKE-UP ADJUSTMENT	16
FOLDER ADJUSTMENT	17
AIR BLOWER TUBE ADJUSTMENT	17
PULLER ADJUSTMENTS	17
PNEUMATIC ADJUSTMENTS	18
ADJUSTING STOP COLLAR ON FEED ROLLER FOR PNEUMATIC MACHINES	19
MAIN FRAME, CAST-OFF PLATE, EYELETS, MISCELLANEOUS COVERS AND BUSHINGS	21
MAIN FRAME, CAST-OFF PLATE, EYELETS, MISCELLANEOUS COVERS AND BUSHINGS (CONT.)	23
CYLINDER COVERS AND BUSHINGS FOR PLAIN FEED	25
CYLINDER COVERS AND BUSHINGS FOR PLAIN FEED (CONT.)	27
CYLINDER COVERS AND BUSHINGS FOR DIFFERENTIAL FEED	29
CYLINDER COVERS AND BUSHINGS FOR DIFFERENTIAL FEED (CONT.)	31
DETACHABLE HEAD ASSEMBLY	33
OILING, NEEDLE LEVER, CRANKSHAFT AND MAIN SHAFT PARTS FOR PLAIN FEED	35
OILING, NEEDLE LEVER, CRANKSHAFT AND MAIN SHAFT PARTS FOR DIFFERENTIAL FEED	37
PLAIN FEED BAR, FEED LIFT & FEED DRIVE COMPONENTS FOR PLAIN FEED	39
DIFFERENTIAL FEED BAR, MAIN FEED BAR, FEED LIFT ECCENTRIC ASSEMBLY FOR DIFFERENTIAL FEED	41
FEED DRIVE COMPONENTS, LOOPER DRIVE COMPONENTS AND LOOPERS FOR PLAIN FEED	43
LOOPERS, LOOPER HOLDERS, FEED DRIVE COMPONENTS AND LOOPER AVOID COMPONENTS FOR DIFFERENTIAL FEED	45
UPPER ROLLER FEED, FOOT LIFTER AND THREAD TENSION PARTS	47
UPPER ROLLER FEED, FOOT LIFTER AND THREAD TENSION PARTS (CONT.)	49
REAR ROLLER & PRESSER FOOT PNEUMATIC COMPONENTS & TREADLE SWITCH	51
PULLER DRIVE ASSEMBLY	53
PULLER BRAKE ASSEMBLY	55
SEWING PARTS FOR PLAIN FEED	57
SEWING PARTS FOR DIFFERENTIAL FEED	59
THREAD STAND	61
ACCESSORIES	62
NUMERICAL INDEX OF PARTS	63
NUMERICAL INDEX OF PARTS	64
NUMERICAL INDEX OF PARTS	65
NOTES	66
NOTES	67



SAFETY RULES

1. Before putting the machines described in this manual into service, carefully read the instructions. The starting of each machine is only permitted after taking notice of the instructions and by qualified operators.

IMPORTANT! Before putting the machine into service, also read the safety rules and instructions from the motor supplier.

2. Observe the national safety rules valid for your country.
3. The sewing machines described in this instruction manual are prohibited from being put into service until it has been ascertained that the sewing units which these sewing machines will be built into, have conformed with the EC Council Directives (89/392/EEC, Annex II B).

Each machine is only allowed to be used as foreseen. The foreseen use of the particular machine is described in paragraph "STYLES OF MACHINES" of this instruction manual. Another use, going beyond the description, is not as foreseen.

4. All safety devices must be in position when the machine is ready for work or in operation. Operation of the machine without the appertaining safety devices is prohibited.
5. Wear safety glasses.
6. In case of machine conversions and changes all valid safety rules must be considered. Conversions and changes are made at your own risk.
7. The warning hints in the instructions are marked with one of these two symbols:



8. When doing the following the machine has to be disconnected from the power supply by turning off the main switch or by pulling out the main plug:
 - 8.1 When threading needle(s), looper, spreader etc.
 - 8.2 When replacing any parts such as needle(s), presser foot, throat plate, looper, spreader, feed dog, needle guard, folder, fabric guide etc.
 - 8.3 When leaving the workplace and when the workplace is unattended.
 - 8.4 When doing maintenance work.
 - 8.5 When using clutch motors without actuation lock, wait until the motor is stopped totally.
9. Maintenance, repair and conversion work (see item 8) must be done only by trained technicians or special skilled personnel under consideration of the instructions.
10. Any work on the electrical equipment must be done by an electrician or under direction and supervision of special skilled personnel.
11. Work on parts and equipment under electrical power is not permitted. Permissible exceptions are described in the applicable sections of standard sheet DIN VDE 0105.
12. Before doing maintenance and repair work on the pneumatic equipment, the machine has to be disconnected from the compressed air supply. In case of existing residual air pressure, after disconnecting from compressed air supply (i.e. pneumatic equipment with air tank), the pressure has to be removed by bleeding.

IDENTIFICATION OF MACHINES

Each UNION SPECIAL machine is identified by a style number, which is stamped into the style plate affixed to the middle of the machine under the tension assembly.

The serial number is stamped in the casting at the right rear base of the machine.

CLASS DESCRIPTION

High Speed, Feed-Off-The-Arm High Throw Machines, Two and Three Needle, Left Needle In Front. Light Weight Presser Bar Mechanism, Adjustable Looper Avoid, Space in Front of Needles 8" (203.2 mm), Single Disc Looper Thread Take-Up, Automatic Enclosed Type Oiling System and Filter Type Oil Pump, Visual Sight Oil Action and Supply Gauges, .588" [19/32", 15.1mm] wide roller.

STYLE OF MACHINES

35800BLW	DOUBLE LAP SEAM. Three needle, high capacity, differential feed with low lift feed eccentric and upper driven roller feed. -Typical Application- For in seams on medium weight denim garments. Seam Specification 401 LSc-3. Standard gauge Number 9 [9/64", 3.6mm]. Recommended needle 130GS, size 125/049. Maximum recommended speed 4500 R.P.M.. .040 step sewing parts.
35800BLWP	Same as 35800BLW except presser and roller bars are equipped with double acting air cylinders. Air is used to supply down pressure and lift for presser foot and roller assembly.
35800BQW	DOUBLE LAP SEAM. Three needle high capacity, plain feed, upper driven, roller feed. - Typical Application- For in and out seams on medium weight denim garments. Seam Specification 401 LSc-3. Standard gauge Numbers 8 [1/8", 3.2mm] and 9 [9/64", 3.6mm]. Recommended needle 130GS, size 125/049. Maximum recommended speed 4500 R.P.M.. .040 step sewing parts.
35800BQWP	Same as 35800BQW except presser and roller bars are equipped with double acting air cylinders. Air is used to supply down pressure and lift for presser foot and roller assembly.
35800BRW	DOUBLE LAP SEAM. Three needle, high capacity, plain feed, upper driven, roller feed. Feed Dogs have higher teeth on front. - Typical Application- For seat seaming, in and out seams on medium to heavy weight denim garments. Seam Specifications 401LSc-3. Standard gauge Numbers 8 [1/8", 3.2mm] and 9 [9/64", 3.6mm]. Recommended needle 130GS, size 140/054. Maximum recommended speed 4500 R.P.M.. .094 step sewing parts.
35800BRWP	Same as 35800BRW except presser and roller bars are equipped with double acting air cylinders. Air is used to supply down pressure and lift for presser foot and roller assembly.
35800BRWL	DOUBLE LAP SEAM. <i>Same as 35800BRW without the folder.</i>
35800BRWPL	Same as 35800BRWL except presser and roller bars are equipped with double acting air cylinders. Air is used to supply down pressure and lift for presser foot and roller assembly.
35800BWW	DOUBLE LAP SEAM. Two and three needle, high capacity, differential feed, high lift feed eccentric, with upper driven, roller feed. Feed Dogs have higher teeth on front. - Typical Application- For in and out seaming on heavy weight denim garments. Seam Specifications 401 LSc-2 or 401 LSc-3. Standard gauge Numbers 8 [1/8", 3.2mm], 9 [9/64", 3.6mm], 18 [9/32", 7.2mm]. Recommended needle 130GS, size 140/054. Maximum recommended speed 4500 R.P.M.. .094 step sewing parts. NOTE: 18 gauge available with two needles only.



STYLE OF MACHINES (CONT.)

35800BWWP	Same as 35800BWW except presser and roller bars are equipped with double acting air cylinders. Air is used to supply down pressure and lift for presser foot and roller assembly.
35800BWWL	DOUBLE LAP SEAM. <i>Same as 35800BWW without the folder.</i>
35800BWWPL	Same as 35800BWWL except presser and roller bars are equipped with double acting air cylinders. Air is used to supply down pressure and lift for presser foot and roller assembly.
35800BWDN	Lower differential feed high step throat plate, wide presser foot with seam groove feed dogs flat front to back belt-driven, wide steel teeth feed roller.
35800BWDR	Plain feed high step throat plate wide presser foot with seam groove raised front teeth on feed dogs belt-driven, wide steel teeth feed roller.
35800BRWH	Same as BWDR above, except with feed dogs flat front to back and smooth rubber feed roller

ILLUSTRATIONS

This manual has been arranged to simplify ordering repair parts. Exploded views of various sections of the mechanism are shown so that the parts may be seen in their actual position in the machine. On the page opposite the illustration will be found a listing of the parts with their part numbers, description and the number of pieces required in the particular view being shown.

Numbers in the first column are reference numbers only, and merely indicate the position of the part in the illustration. The reference number should never be used in ordering parts. Always use the part number listed in the second column.

Component parts of sub-assemblies which can be furnished for repairs are indicated by indenting their descriptions under the description of the main sub-assembly. As an example refer to the following text.

9.	29126 EC	Upper Looper Drive Shaft Assembly	1
10.	22503 F	Screw	1
11.	39543 E	Cam Follower Locking Clamp	1

It will be noted in the previous example that the cam follower, bushing and cam guide and the upper looper drive shaft are not listed. The reason is that replacement of these parts individually is not recommended, so the complete upper looper drive shaft assembly should be ordered.

When a part is common to all machines covered in this manual, no specific usage will be mentioned in the description. However, when the parts for the various machines are not the same, the specific usage will be mentioned in the description and, if necessary, the difference will be shown in the illustration.

A numerical index of all the parts shown in this manual is located at the back. This will facilitate locating the illustration and description when only a part number is known.

IDENTIFYING PARTS

Where the construction permits, each part is marked with its part number. On some of the smaller parts and on those where construction does not permit, an identification letter is marked in to distinguish the part from similar ones.

PLEASE NOTE: Part numbers represent the same part, regardless of which manual they appear. On all orders please include part number, name and style of machine for which the part was ordered.

TERMS

Prices are net cash and subject to change without notice. All shipments are forwarded F.O.B. shipping point. A charge is made to cover postage and insurance.



THREADING & OILING FOR PLAIN FEED

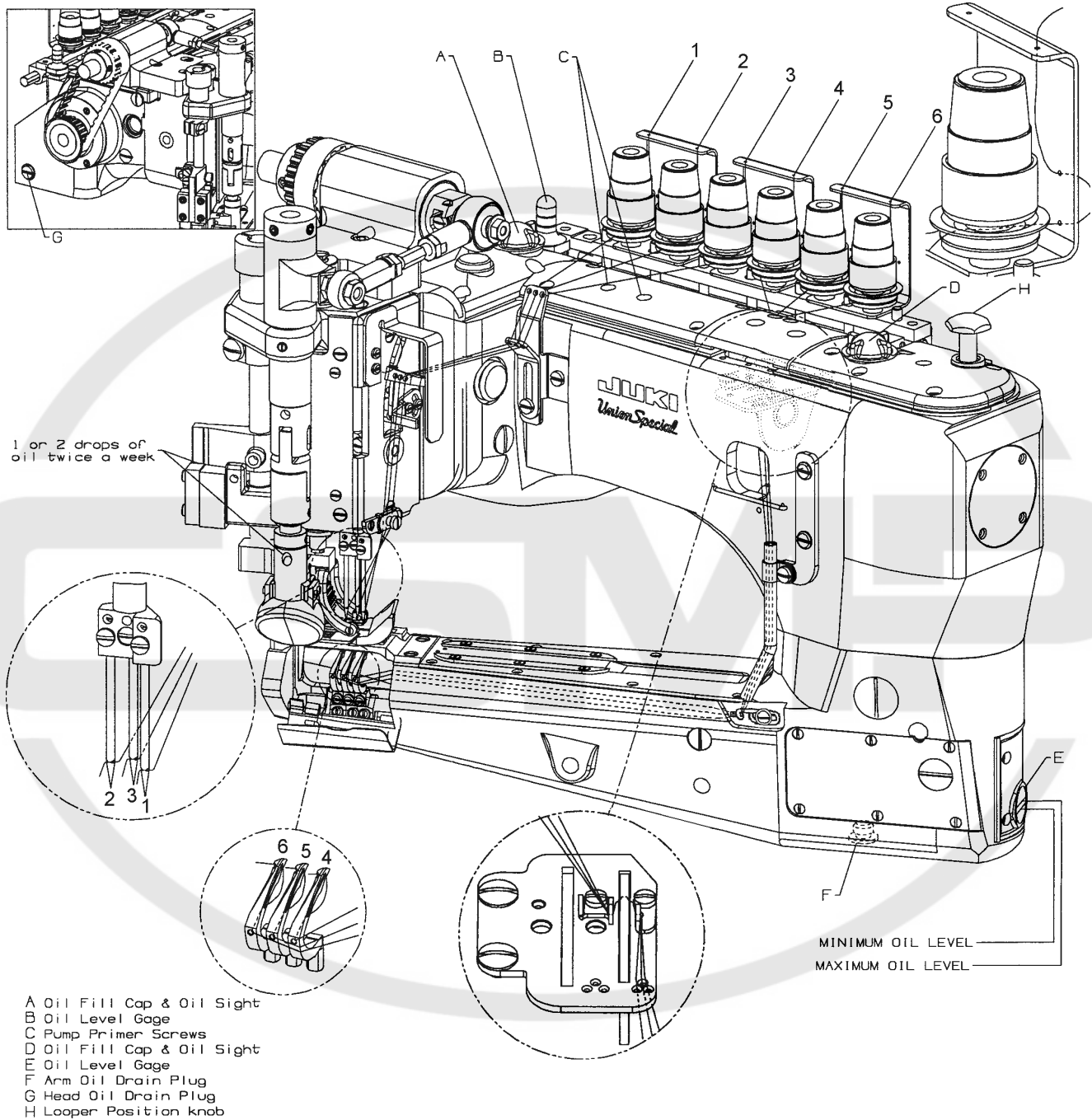

FIG. 1

THREADING & OILING FOR DIFFERENTIAL FEED

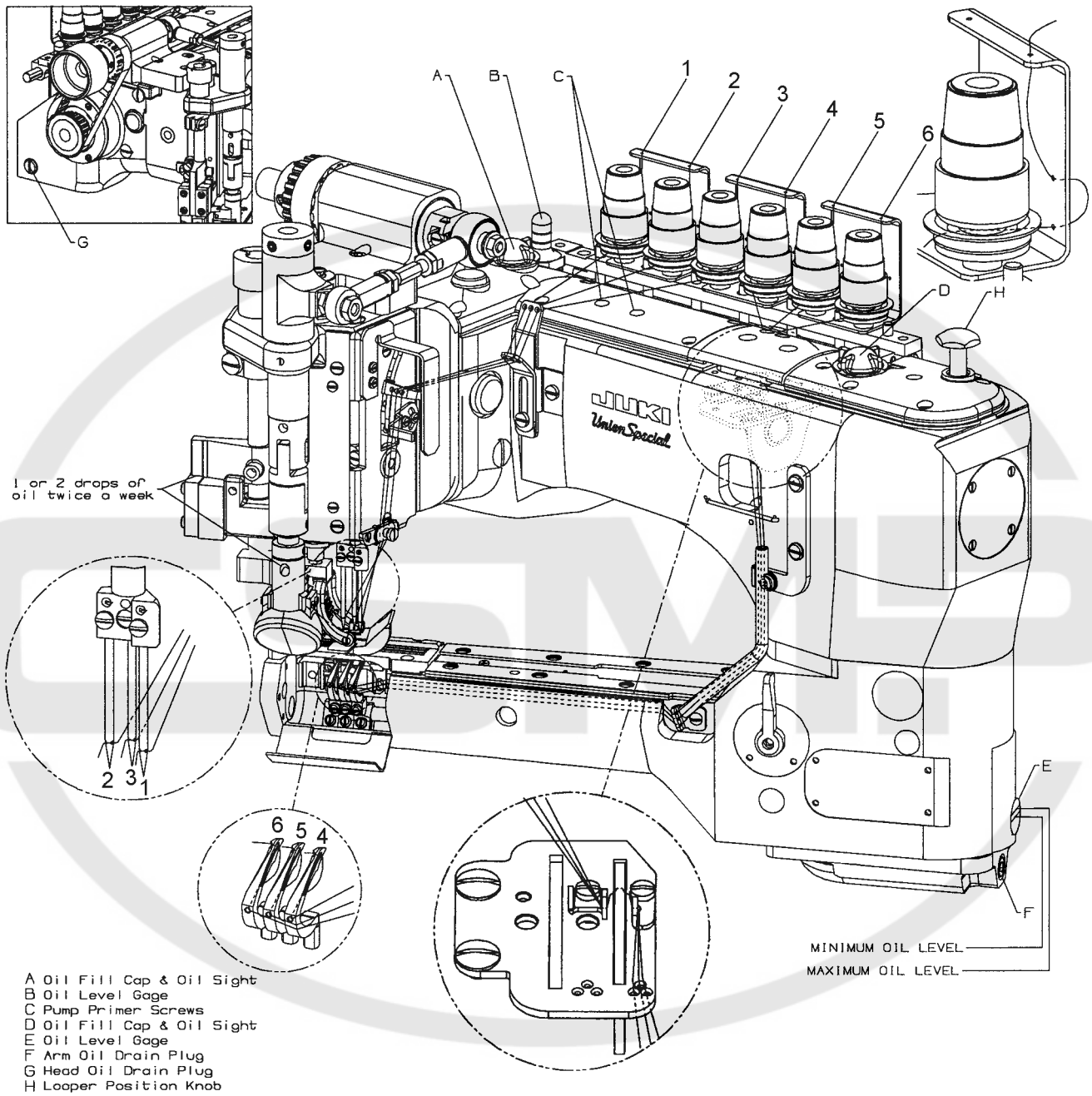

FIG. 1

Needle Type	Description	Sizes Available
130GS	Short double groove, struck groove, ball eye, spotted, government point, chromium plated.	080/032, 090/036, 100/040, 110/044, 125/049, 140/054, 150/060

Table I
NEEDLES

Selection of proper needle size is determined by size of thread used. Thread should pass freely through the needle eye in order to produce a good stitch formation.

Each needle has both a type and size number. The type number denotes the kind of shank, point, length, groove, finish and other details. The size number, stamped on the needle shank, denotes largest diameter of blade, measured midway between shank and eye. Collectively, type and size number represent the complete symbol which is given on the label of all needles packaged and sold by UNION SPECIAL. See "STYLE OF MACHINES" for the standard recommended needle type & size for your machine.

To have needle orders promptly and accurately filled, an empty package, a sample needle, or the type and size number should be forwarded. Use the description on the label. A complete order would read: "1000 Needles, Type 130GS, Size 140/054".

LUBRICATION

The oil has been drained from the machine before shipping and the reservoirs must be filled before beginning to operate. Use a straight mineral oil with a Saybolt viscosity of 90 to 125 seconds at 100° Fahrenheit. Union Special Part No. 28604R.

Oil is filled at oil caps (A & D, Fig. 1). The level is checked at sight gauges (B) and (E). Maintain the oil level between the red lines of the gauges.

The machine is equipped with a continuous running rotary driven oil pump. The action of the oil can be observed through oil sight (A) and (D) in the front and back top covers.

When starting a new machine, filling the reservoirs or when beginning to operate a machine that has been idle for some time, it may be necessary to prime the pump. To do this, remove the two plug screws (C). Apply oil to these holes and operate machine until bubbling can be observed at the windows. Replace screws (C).

CAUTION: If oil does not bubble when machine is running, the circulating pump is inoperative.

Oil may be drained from the machine at two places, plug screw (F) located in the bottom of the cylinder and plug screw (G) at the back of the main frame below the handwheel.

THREADING

A convenient means for threading the looper has been provided. When loopers are at the left end of their travel, press the knob (H, Fig. 1) and loopers will back out of position, leaving them easily accessible. Thread the machine as illustrated in (Fig. 1). After threading, push loopers back into position.

ADJUSTING INSTRUCTIONS

NOTE: Instructions stating direction of location, such as right, left, front or rear of machine, are given relative to operator's position at the machine. The handwheel rotates counterclockwise, in operating direction; when viewed from the right end of machine.

TORQUE REQUIREMENTS

Torque specifications given in this catalog are measured in inch-pounds or Newton-meters. All straps and eccentrics must be tightened to 19-21 in. lbs. (2.1-2.3Nm) unless otherwise noted. All nuts, bolts, screws, etc., without torque specifications must be secured as tightly as possible, unless otherwise noted. Special torque specifications for connecting rods, links, screws etc., are shown on the parts illustrations.

SYNCHRONIZING NEEDLE AND LOOPER MOTIONS

NOTE: Needle and looper mechanisms are carefully synchronized with precision gauges before leaving the factory to insure the best possible sewing conditions.

Should it become necessary to disassemble the main shaft or replace components of the needle or looper drive mechanisms, re-synchronization of the machine will be required to facilitate proper sewing adjustments. This is accomplished by means of an adjustable split coupling located beneath the rear top cover, connecting the crankshaft to the main shaft, which in turn drives the looper mechanism.

To synchronize the machine, remove the needles, presser foot, throat plate, feed dogs and upper feed roller mechanism. Rotate handwheel in the operating direction until the needle bar is at the bottom of its stroke and just begins its upward travel. Loosen screw (A, Fig. 2) and remove the looper for the left hand needle from the looper holder. Insert a straight steel rod (B) $5/32"$ (3.9mm) or $11/64"$ (4.3mm) diameter by $2-1/2"$ (63.5mm) long into looper holder and retighten screw (A). It may be necessary to reposition the looper holder so that the rod (B) will be in a vertical position when at its farthest travel to the right. Rotate the handwheel until the rod is at extreme left, reinstall the throat plate. Turn the handwheel in the operating direction, with needle bar rising until rod (B) comes in contact with the edge of the throat plate. At this point, clamp Union Special timing gauge TT147 (C) around the needle bar (D), flush against the underside of the machine casting (E). Rotate handwheel in the opposite direction until either the gauge contacts the machine casting on the up stroke of the needle bar or the rod contacts the edge of the throat plate. Maximum allowable clearance between gauge and casting or rod and throat plate is $.005"$ (0.1mm)

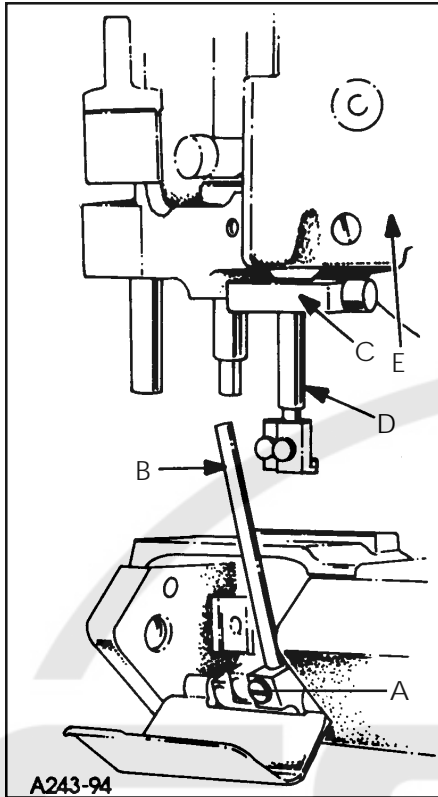

FIG. 2

If machine is not synchronized the following applies:

Both ends of the adjustable split coupling are secured to the crankshaft and main shaft by spot screws and set screws. On the main shaft end of the coupling (A, Fig. 3) three screws (B) thread horizontally through the coupling. The holes in the main shaft end of the coupling are larger than the diameter of the screws, permitting several degrees of rotation in either direction to properly synchronize the needle and looper. Loosen the three horizontal clamp screws (B, Fig. 3). With rod (B, Fig. 2) at its farthest position to the left, snug the uppermost horizontal clamp screw enough to hold coupling (A, Fig. 3) in position. If the handwheel is turned in reverse of operating direction and gauge (C, Fig. 2) on needle bar (D) contacts the machine casting (E) before rod (B) contacts the edge of the throat plate, loosen horizontal clamp screw (B, Fig. 3) which was snug, while holding the coupling in place with an Allen wrench in set screw (C). Rotate the handwheel slightly in reverse of operating direction, snug the uppermost horizontal clamp screw (B), recheck synchronization. If the handwheel is turned in reverse of operating direction and the rod contacts the edge of the throat plate before the clamp gauge contacts the machine casting, adjust as before, except turn the handwheel slightly in the

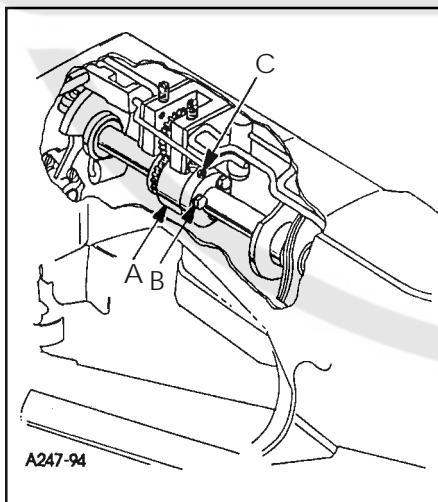

FIG. 3

operating direction. Use shim stock to insure no more than $.005"$ (0.1mm) exists between gauge and casting or between rod and throat plate, in both the operating and reverse directions of the handwheel. When this setting has been made, tighten the three horizontal clamp screws (B, Fig. 3) securely, and recheck both clearance points with $.005"$ (0.1mm) shim gauge to assure no slippage occurred while tightening the screws.

TIGHTENING NEEDLE HEAD

When replacement of the needle bar, and or needle head is necessary, torque the needle head to needle bar 14-16 in. lbs. (1.6-1.8Nm) or use torque rod No. 21227AR that has been supplied with the machine, for the purpose of eliminating the possibility of distorting the needle bar due to overtightening. Insert the torque rod in the hole at the upper end of the needle bar, while holding the needle bar head with a suitable tool, turn the needle bar with the torque rod onto the needle bar head. When the rod starts to bend, the needle bar head has been threaded into the needle bar properly.

ALIGNING NEEDLES IN THROAT PLATE SLOTS

Insert a new set of needles, type and size specified, with screw (B, Fig. 4) slightly loosened, lower needle bar (A) and turn needle head as required until the needles are centered in the throat plate needle hole slots. Tighten screw (B) torque to 19-21in.lbs. (2.1-2.4Nm).

NOTE: If the needles can not be aligned in the throat plate slots, the lower cylinder must be moved as stated below.

CENTERING THE CYLINDER

Remove the top front cover and gasket from the main frame. Loosen cylinder holding screw (A, Fig. 5). Turn eccentric screw (B) clockwise or counterclockwise to move the cylinder so the needles are centered in the needle holes. Tighten screw (A) and recheck settings.

NOTE: The cylinder may not move freely when the eccentric is turned because the joint sealant compound has set.

SETTING THE LOOPER

Insert a new set of needles, type and size specified. Always adjust the looper (A, Fig. 6) for the left needle first. Set the looper so that the distance from the center of the needle (B) to the point of the looper (A) is $9/64$ " (3.6mm) when the looper is at its farthest position to the left. Looper gauge (C) No. 21225-9/64 can be used advantageously in making this adjustment. If adjustment is required, loosen screw (A, Fig. 7) in looper holder, permitting movement in either direction to attain the $9/64$ " (3.6mm) dimension as shown in Fig. 6. Retighten screw (A, Fig. 7). Repeat for other needles and loopers.

Rotate handwheel in operating direction to assure that the looper point passes to the rear of the needle to touch but not to deflect the needle. This adjustment can be made by loosening screw (A, Fig. 7) in looper holder. Looper holder can be moved front to back to attain looper to needle setting. Always check the $9/64$ " (3.6mm) looper gauge setting after setting the looper to the back of the needle, and conversely, always check the setting of the looper to the back of the needle after setting the $9/64$ " (3.6mm) looper gauge.

The amount of looper avoid has been set at the factory to .110" (2.8mm). If it becomes necessary to adjust the amount of avoid it is recommended as a starting point, to have the points of the descending needles contact the back of the lower 1/3 of the back of the looper blade. (See Fig. 7).

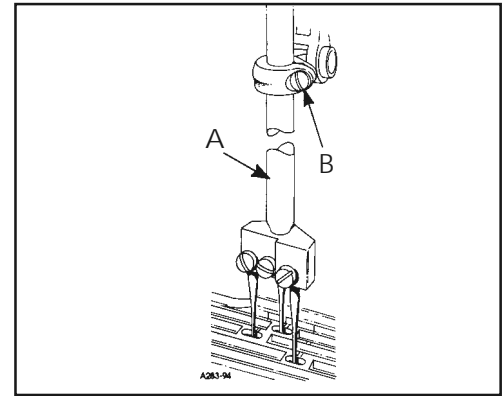

FIG. 4

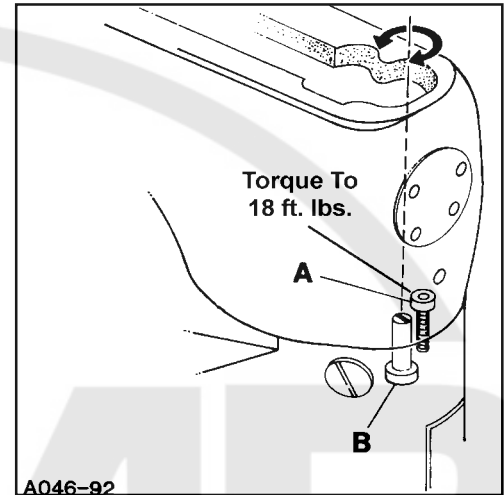

FIG. 5

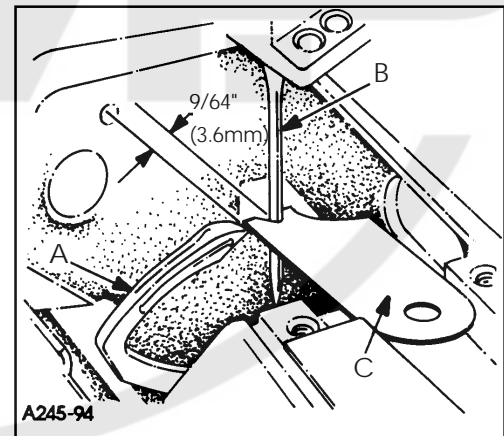

FIG. 6

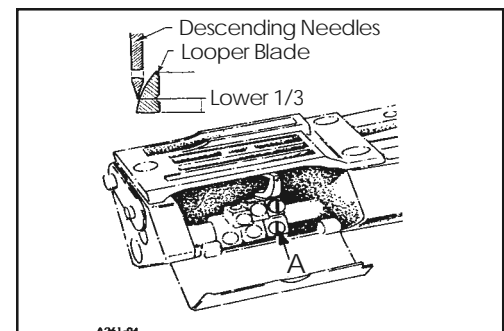

FIG. 7

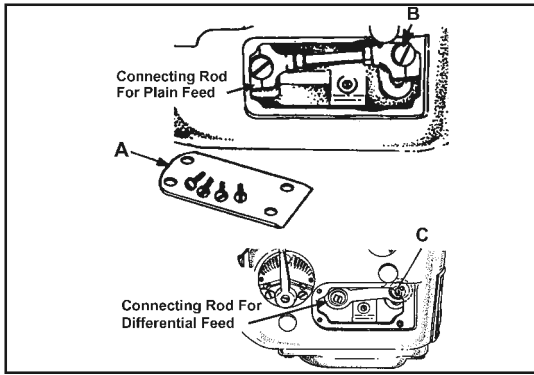

FIG. 8

SETTING THE LOOPER AVOID PLAIN FEED

If more or less looper avoid motion is required, remove cylinder side cover (A, fig 8) located at the lower front left side. For Plain feed use a screwdriver to loosen looper avoid link ball joint (B, fig 8) (for differential feed use TT-5 wrench to loosen looper avoid link screw C, fig 8). Moving ball joint down in the lever slot increases the amount of looper avoid motion, moving it up acts the reverse. Retighten ball joint B, Plain feed (screw C, differential feed) securely.

NOTE: Whenever looper avoid is changed looper clearance to needle must also be reset.

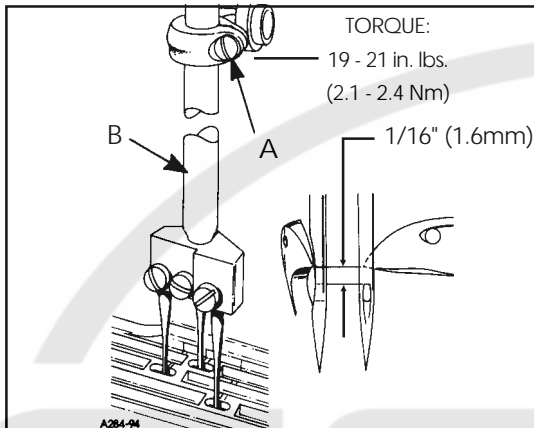

FIG. 9

SETTING HEIGHT OF NEEDLE BAR

The height of the needle bar is correct when the top of the needle eye is 1/16" (1.6mm) below the underside of the looper, with the looper point even with the right side of the needle. To make adjustment loosen screw (A, Fig. 9) and move needle bar (B) as required to attain dimension.

NOTE: Care must be taken not to disturb the alignment of the needles when moving the needle bar either up or down.

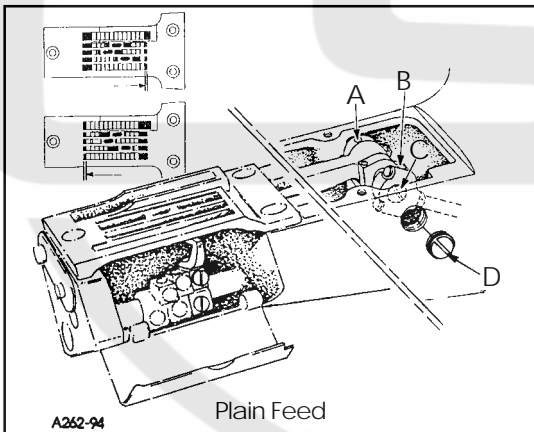

FIG. 10

SETTING THE FEED DOGS FOR PLAIN FEED

Assemble the main feed dog and throat plate. Main feed dog (A, Fig. 11) at its highest position, should be set to project above the throat plate, slightly more than the depth of its teeth for Style 35800BQW and slightly more than the depth of its lower teeth for Styles 35800BRW, BRWL. The feed dog mounting screw (B) and front support screw (C) should be set to maintain this setting.

The feed should be set so there is equal clearance between the front of the feed dog and the front of the feed slot in the throat plate when the feed dog is at its most forward travel. The same amount of clearance should be between the back of the feed dog and the back of the feed slot in the throat plate when the feed dog is at its most rearward travel. To attain this setting loosen screws (A and B, Fig. 10) and remove plug screw (D). Using a screw driver turn eccentric pin (C) clockwise or counterclockwise to obtain proper setting. Tighten screws (A and B), reinstall plug screw (D).

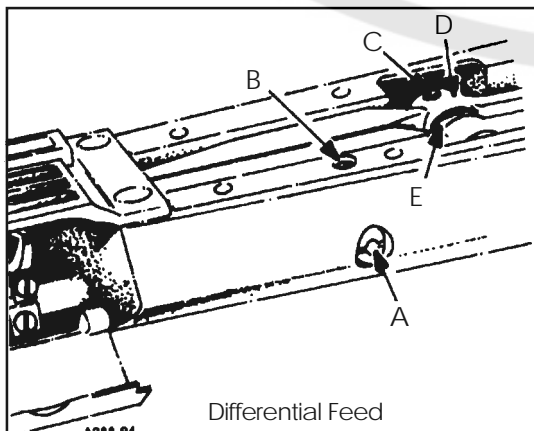

FIG. 10A

SETTING THE FEED DOGS FOR DIFFERENTIAL FEED

Before assembling the main and differential feed dogs, set the feed bar eccentric pin (A, Fig. 10A) located in the left side near center of cylinder, so that the slot in the head is in a horizontal position for the 35800BWDN, BLW style machines and turned counter clockwise to an approximate 45° for the 35800BWW style of machine. The pin can be used to slightly tilt both feed dogs if necessary. The feed bar pin is retained in position by set screw (B). Assemble differential feed dog (A, Fig. 11A), main feed dog (B) and throat plate. Both the main and differential feed dogs can be individually adjusted to height. Main feed dog (B) at its highest position, should be set to project above the throat plate, the depth of its teeth. If adjustment is necessary loosen screw (D) and move feed dog (B) up or down to attain correct setting. Feed dog support (C) should support front of feed dog.

NOTE: If eccentric pin (A, Fig. 10A) is used to tilt the feed dogs, make sure that the looper does not interfere with the rear needle guard and that the needle guard does not pinch the needle loops on the back side of the needles.



SETTING THE FEED DOGS FOR DIFFERENTIAL FEED (CONT.)

If adjustment is necessary loosen screw (E, Fig. 11A) in feed dog support (C) and move as required. Retighten screw (E). The differential feed dog (A) may then be leveled with main feed dog (B). If adjustment is necessary loosen screw (F) and move feed dog up or down as required. Retighten screw (F).

NOTE: Should the main feed dog require repositioning due to contact with the throat plate in its forward or rearward travel, loosen set screw (C, Fig. 10A) in main feed bar driving link (D), rotate main feed bar eccentric driving stud (E) as required. Driving stud (E) has a thin hexagon head with cutouts on two of the flats allowing movement by tapping with a sharp pointed tool, when wrench 21388AZ is not available. Whenever the main feed bar eccentric driving stud position has been changed, recheck rear needle guard setting, adjustment may be required. Retighten set screw (C). Position main feed dog support (C, Fig. 11A) flush against bottom of main feed dog (B), tighten support screw (E) securely.

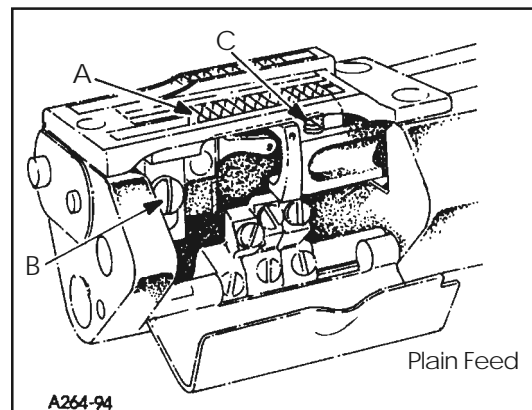

FIG. 11

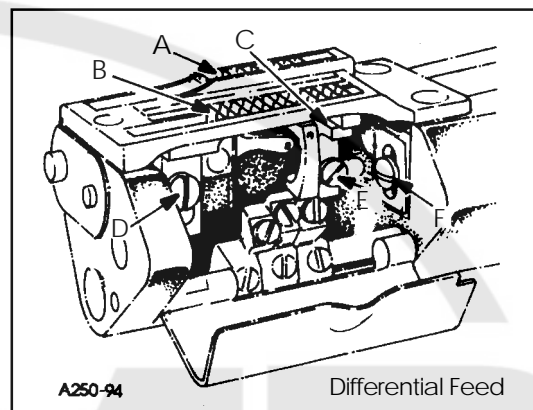

FIG. 11A

CHANGING STITCH LENGTH

When change in stitch length is required, remove large plug screw (A, Fig. 12). Loosen feed rocker driving link screw (B) in lever (C). Moving the feed rocker driving link up in the lever slot lengthens the stitch, moving it down, shortens the stitch. Retighten link screw (B) securely and replace plug screw (A).

NOTE: If plug screw (A) is replaced with a new plug screw, it should be sealed with a silicone seal.

Any stitch length change, requires resetting the needle guard.

CAUTION: When making stitch length adjustment do not exceed maximum recommended stitch length due to possible part damage.

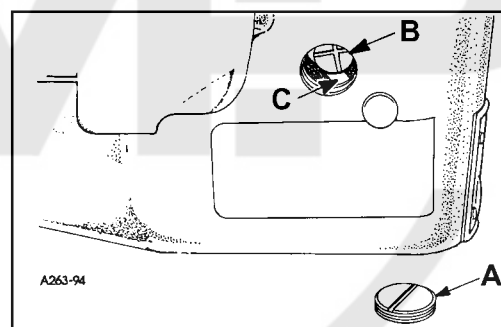

FIG. 12

SETTING REAR NEEDLE GUARD

Set the rear needle guard (A, Fig. 13) horizontally so that it barely contacts needles (B) when at its extreme forward position. If adjustment is necessary loosen screw (E) and move guard front to back as required. It should be set vertically as low as possible, yet have its guarding surface in contact with the needles until the points of the loopers (C), moving to the right, are even with the right side of the needles. If adjustment is necessary loosen screw (F) and move guard and holder up or down as required.

CAUTION: If stitch length is changed, needle guard must be reset.

NOTE: When installing the needle it should be parallel with the eye in line of feed. If adjustment is necessary, loosen screw (N, Fig. 15) in needle head and rotate needle to attain adjustment (D, Fig. 13).

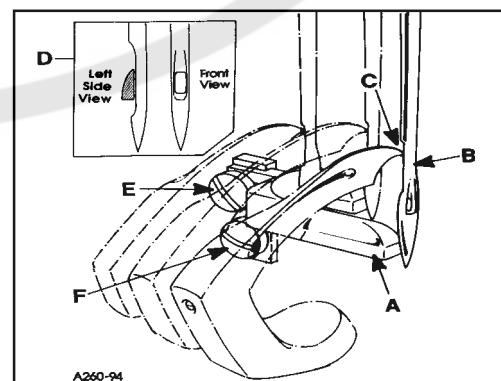

FIG. 13

PRESSER FOOT AND PRESSER BAR ADJUSTMENT

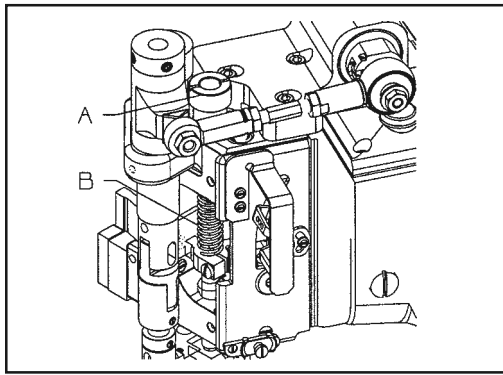

FIG. 14

Adjusting or Replacing Presser Foot:

Remove presser bar knob (A, Fig. 14) and spring (B). Loosen screw (A, Fig. 15) on presser bar guide (B). (Loosen screws (C) in upper stop collar for pneumatic machines only). Slide presser bar upward high enough to slip on presser foot yoke (E) with foot attached and tighten screw (F) on flat of presser bar. Position foot so that the needle holes in the foot line up with the holes in the throat plate. Tighten screw (A)

Presser foot guide plates (G, Fig. 15) should be set so that entire presser foot and bar assembly has free movement up and down with no left to right movement.

With foot properly aligned on throat plate and presser bar guide (B) securely fastened to presser bar, adjust both guide plates (G) to obtain above setting. Tighten four screws (H).

Reinstall presser bar spring (B, Fig. 14) and knob (A), with presser foot resting on throat plate.

For pneumatic machines:

Set upper stop collar (K) to contact casting, so the bottom of the needle head and the top of the presser foot do not touch, at the bottom of the needle stroke when lifting foot. Tighten screw (C).

The presser foot should be adjusted to be 1/8" (3.17mm) above the throat plate before the feed roller mechanism begins to rise. Loosen screw (A, Fig. 15) in presser bar lifter and guide (B, Fig. 15), raise or lower guide as required to attain the specified point at which the feed roller begins to rise. Retighten screw (A) and maintain needle settings.

NOTE: There should be a minimum 1/32" (0.8mm) clearance between screw (M, Fig. 15) and the bottom of the slot in link (J).

Regulate the pressure on the presser foot by turning the presser spring regulating knob (A, Fig. 14) located on top of pressure foot spring (B).

To remove just the presser foot, remove screws (L, Fig. 15) and replace foot, retighten screws (L).

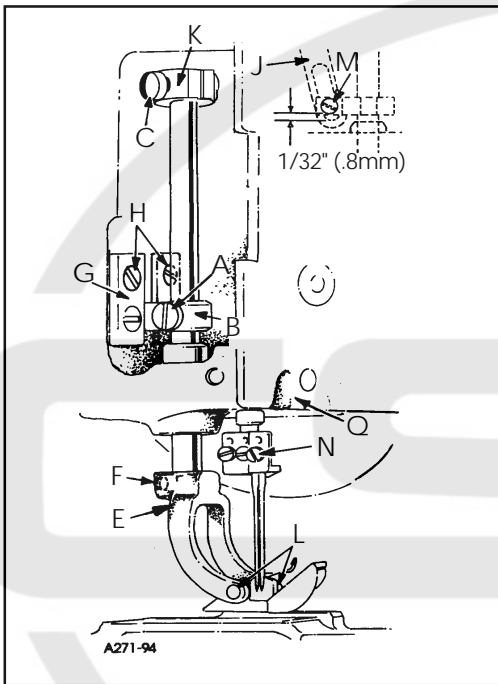

FIG. 15

UPPER FEED ROLLER ADJUSTMENT

Assembly of Roller to Roller Yoke:

Assemble driven gear (A, Fig. 16) through feed roller frame (B). Place woodruff key (C) into slot of feed roller shaft (D). Slide driven gear (E) on to shaft (D), make sure key (C) goes into slot in gear (E). While holding feed roller frame (B) with steel roller (F) between the two frame lobes, slide feed roller shaft (D) and assembled components through frame. Make sure that shoulder of roller (F) is to the right. Align screw (G) (first in operating direction on roller) on the flat of shaft (E). At the same time thrust shoulder of shaft (D) against face of gear (E), make sure left edge of roller is against right (inside) face of left lobe. Secure screw (G) on flat of shaft (D) and tighten screw (H).

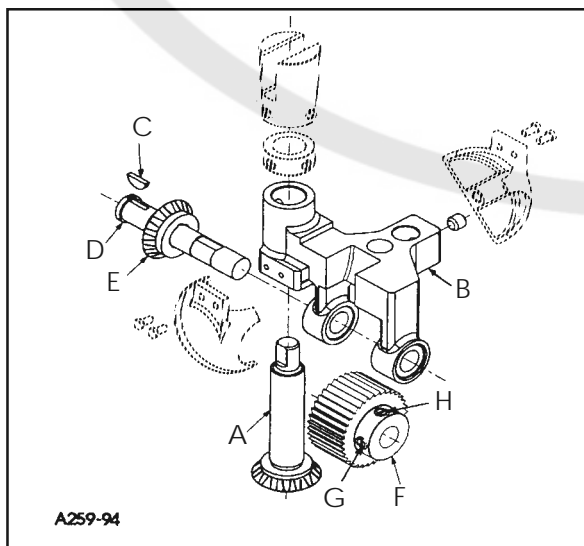

FIG. 16

UPPER FEED ROLLER ADJUSTMENT (CONT.)

When feed roller mechanism (C, Fig. 17) has been removed or replaced, .003" (0.08mm) minimum to .005" (0.13mm) maximum clearance should be maintained between roller and throat plate.

To Adjust Guiding System for Roller:

Loosen two screws (A). Using shim(s) adjust feed roller mechanism (C) so that the roller is .003" (0.08mm) to .005" (0.13mm) above throat plate. Slide rear guide finger (B) down so that it sits on top of rear guide support block (D). Check to make sure roller is parallel to throat plate slots. Tighten two screws (A) to secure feed roller mechanism in place.

Setting Pressure for Feed Roller:

Regulate the pressure on the feed roller so that it exerts only enough pressure on the fabric to feed the work uniformly. Turning roller presser spring regulator (H, Fig. 17) clockwise to increase or counterclockwise to decrease the pressure.

Setting of Feed Roller:

Guide finger for roller should be set so that entire roller mechanism has free movement up and down with no left to right movement. With roller properly aligned, the edge of roller should be parallel with feed slots in throat plate.

Guide plates (F) must be thrust against guide finger (B) to secure feed roller mechanism (C). Thrust guide plates (F) against guide finger (B) with equal pressure. Tighten four screws (E) to hold plates in place.

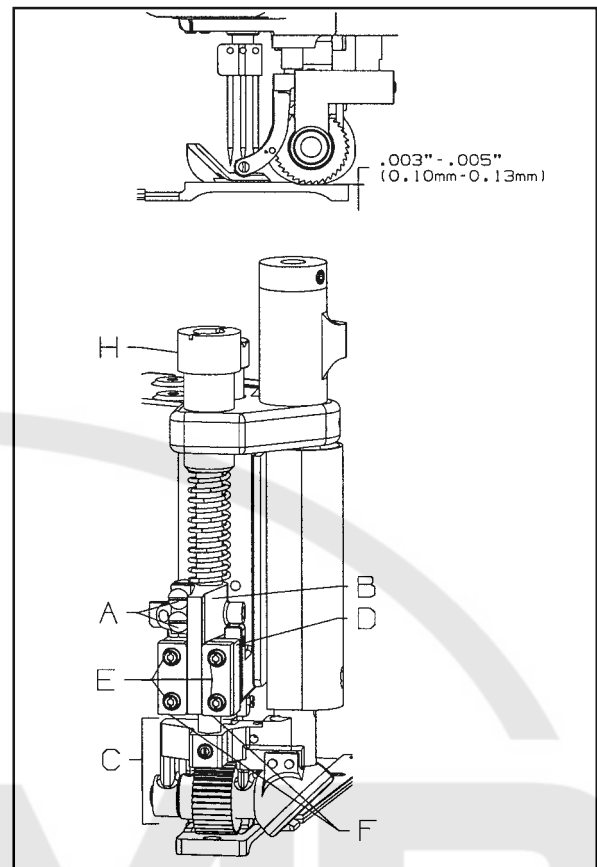

FIG. 17

THREAD TENSION AND RELEASE

The thread tension release is set correctly when it begins to function at the point when the upper feed roller begins to rise. When adjustment is necessary, loosen screw (B, Fig. 18) in lifter lever (C). Facing the tension release shaft (A) from the right end of the machine, insert screwdriver in slot in shaft (A). Turn the screwdriver clockwise to raise pins (D) or counterclockwise to lower pins. Retighten screw (B).

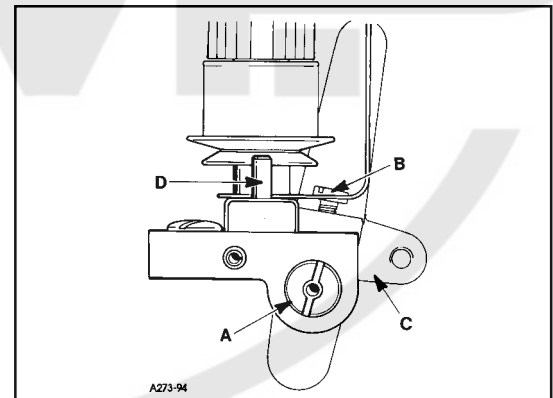

FIG. 18

DIFFERENTIAL CONTROL

The amount of differential is controlled by lever (A, Fig. 19). The adjusting plate is numbered from 1 to 9. When the lever is set from numbers 1 to 4 reverse differential or stretching occurs. The numbers from 4 to 5 produce equal feed stitching while numbers 5 to 9 produce a gathering stitch. Screws (B) can be set to limit the movement of lever (A) or lock lever in one position. If top ply of material is coming out long, move lever toward operator, if top ply is short, move lever away from operator, as required.

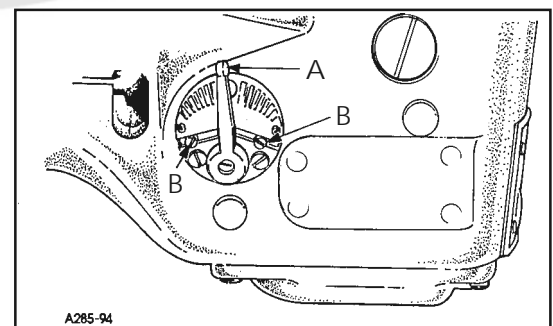

FIG. 19

SETTING NEEDLE THREAD TAKE-UP AND FRAME EYELET

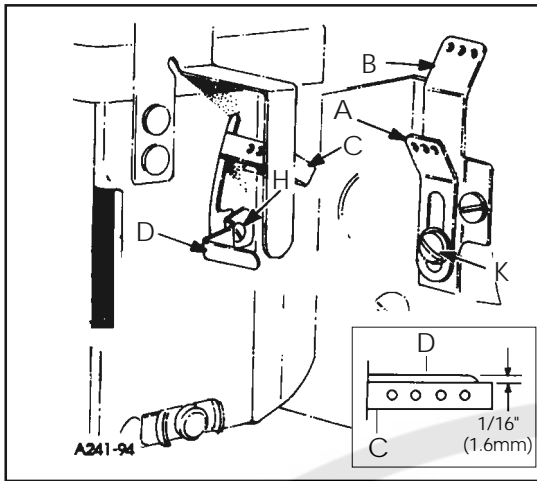

FIG. 20

With the needle bar at the top of its stroke set the adjustable frame needle thread eyelet (A, Fig. 20) in the lower mounting hole of eyelet (B) so the needle thread from eyelet (A) to the needle lever thread eyelet (C) will be in a straight line. If adjustment of eyelet (A) is necessary loosen screw (K) and move eyelet up or down as required. Retighten screw (K).

With the needle bar at the bottom of its stroke, the needle thread take-up (D) should be set so that it is 1/16" (1.6mm) above the edge of the needle lever thread eyelet (C) (See Inset). If adjustment is necessary loosen screw (H) and adjust lever (D) as required to attain 1/16". Tighten screw (H).

LOOPER THREAD TAKE-UP ADJUSTMENT

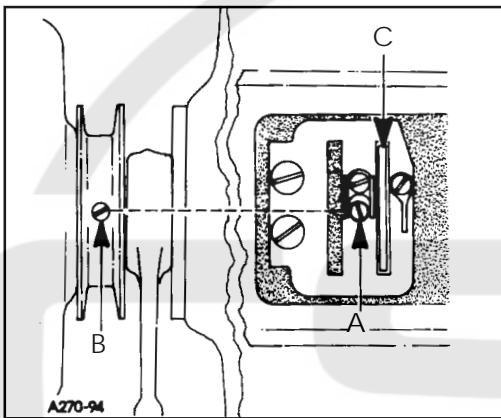

FIG. 21

With the machine rotating in operating direction the looper thread take-up is in time when the first screw coming into view (A, Fig. 21) is in line with the spot screw (B) on the main shaft in the pulley. NOTE: screw (A) is accessible through the hole in the take-up. With this setting correct, the looper thread should cast-off of the take-up (C) when the needles are safely in the triangle. If adjustment is necessary loosen two screws (A) in take-up (C) position screws in line with spot screw (B). Tighten screws (A).

NOTE: Make sure take-up cam is centered left to right in cast-off slot.

FOLDER ADJUSTMENT

Slide folder (A, Fig. 22) on arm. The folder should be as close to the front of presser foot (B) as possible, making sure to avoid the presser foot contacting the folder when sewing across seams. If adjustment is necessary loosen screws (C) to move entire folder left to right or front to back as required. If just adjustment of upper scroll (D) is needed loosen screw (E) and position scroll to obtain proper seam margin.

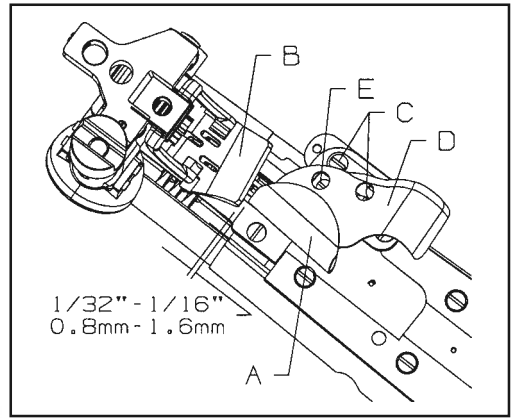

FIG. 22

AIR BLOWER TUBE ADJUSTMENT

The air blower tube should be set left to right so it is parallel with the throat plate. It should be set front to back so when feeding over a cross seam the presser foot does not contact the tube. If adjustment is necessary, loosen screw (A, Fig. 23) and position air blower tube (B) as required. Retighten screw (A).

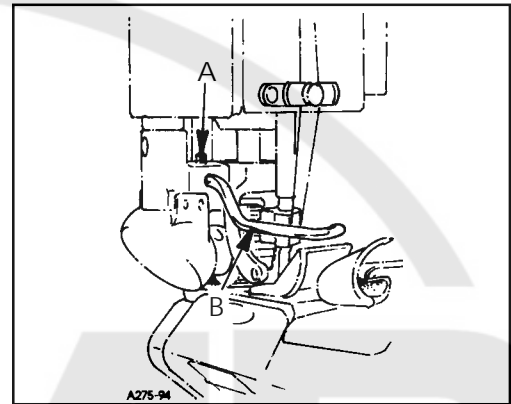

FIG. 23

PULLER ADJUSTMENTS

Timing of the Puller Mechanism:

Loosen two screws (A, Fig. 24) in upper sprocket, rotate machine in operating direction, with needle moving up until needle points are flush with top of throat plate (B). At this point, feed dogs are above throat plate but have not made any movement towards the rear. Rotate puller shaft (C) in operating direction until puller (D) shows some movement clockwise. At this time tighten two screws (A) in upper sprocket.

Setting Travel of Puller (stitch length):

Loosen nut (E, Fig. 24) and turn screw (F) clockwise to shorten puller travel or counterclockwise to lengthen puller travel. Tighten nut (E). Sewing sample should be checked to assure that proper stitch length is obtained.

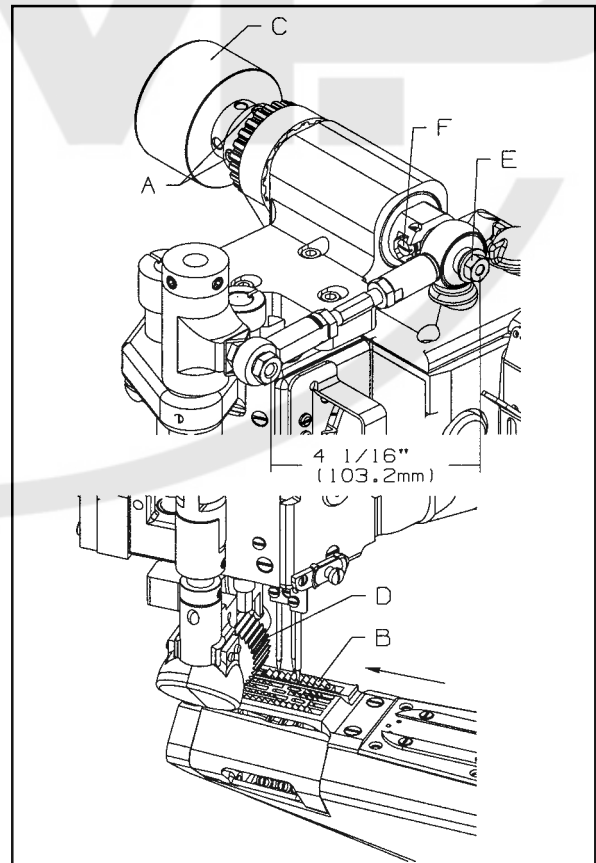

FIG. 24

PNEUMATIC ADJUSTMENTS

Pneumatic settings can vary between different sewing applications. For best results set all air lines and air pressure settings as in (Fig. 25).

If air lines are disconnected follow connection as in (Fig. 25).

Air pressure settings should be set with air regulators as shown in (Fig. 26).

Air lines should be attached with each end of line to corresponding letter (Fig. 25).

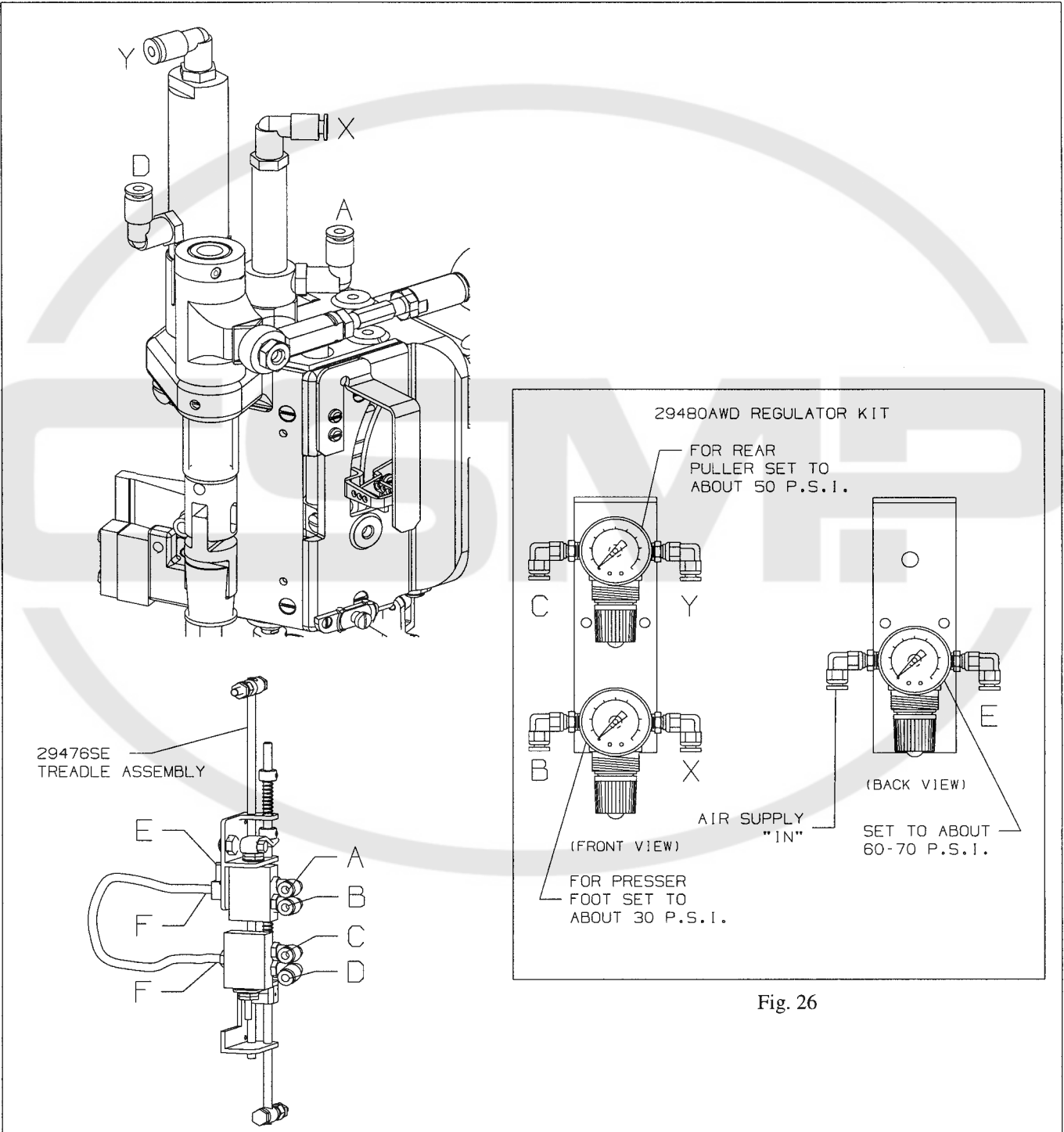

Fig. 25

Fig. 26



ADJUSTING STOP COLLAR ON FEED ROLLER FOR PNEUMATIC MACHINES

When feed roller mechanism (A, Fig. 27) and/or puller shaft cylinder assembly (B, Fig. 27) has been removed or replaced, 1/64" (0.4mm) clearance should be maintained between upper connection (C, Fig. 27) and floating feed roller connection (D, Fig. 27) when feed roller mechanism is in up position.

Turn off air supply to puller shaft air cylinder assembly (B, Fig. 27). Loosen screw (E, Fig. 27). Lift feed roller mechanism (A, Fig. 27) until there is 1/64" (0.4mm) clearance between upper connection (C, Fig. 27) and floating feed roller connection (D, Fig. 27). Slide roller stop collar (F, Fig. 27) and rubber washer (H, Fig. 27) up until they contact the underside of head assembly (G, Fig. 27). Retighten screw (E, Fig. 27).

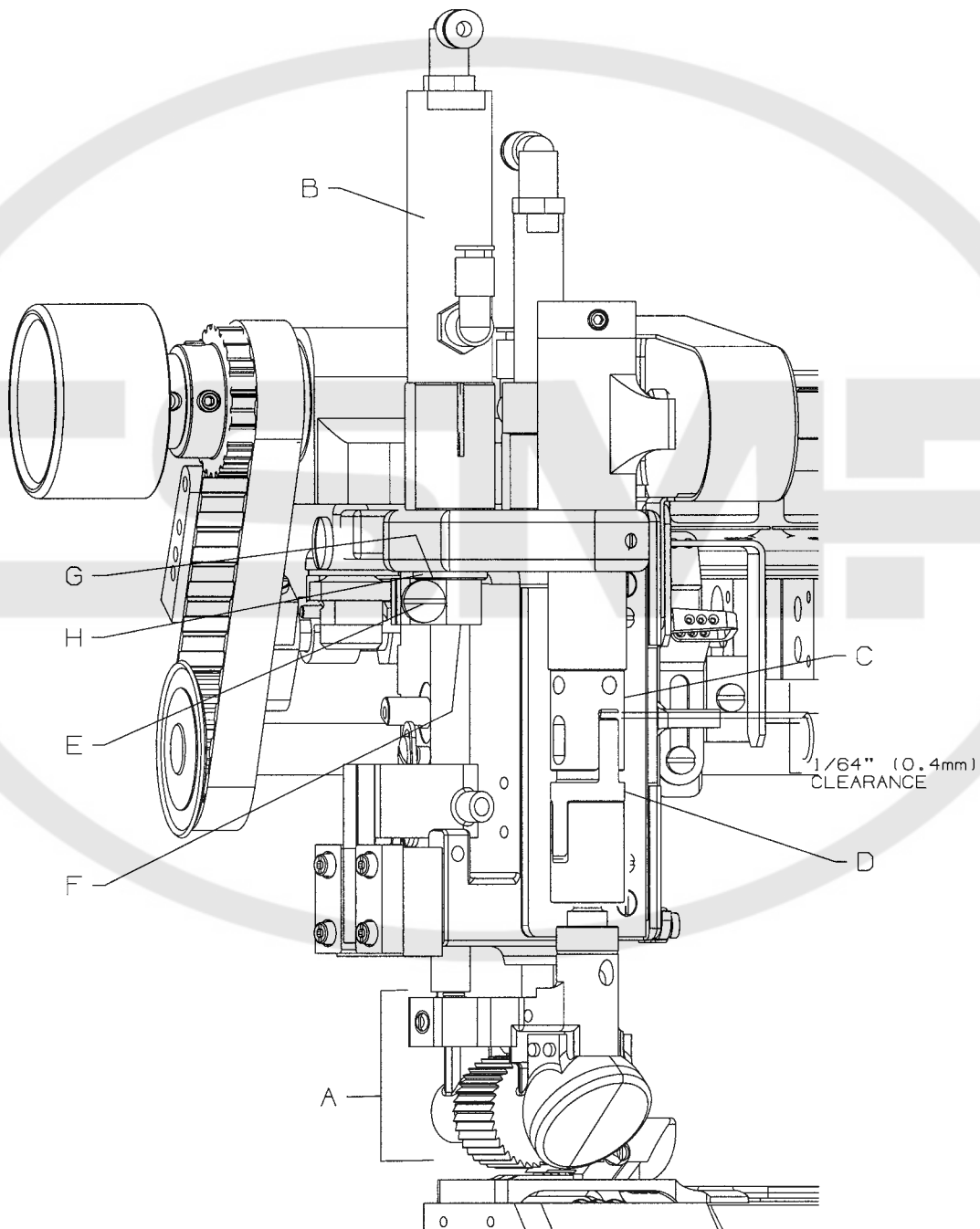
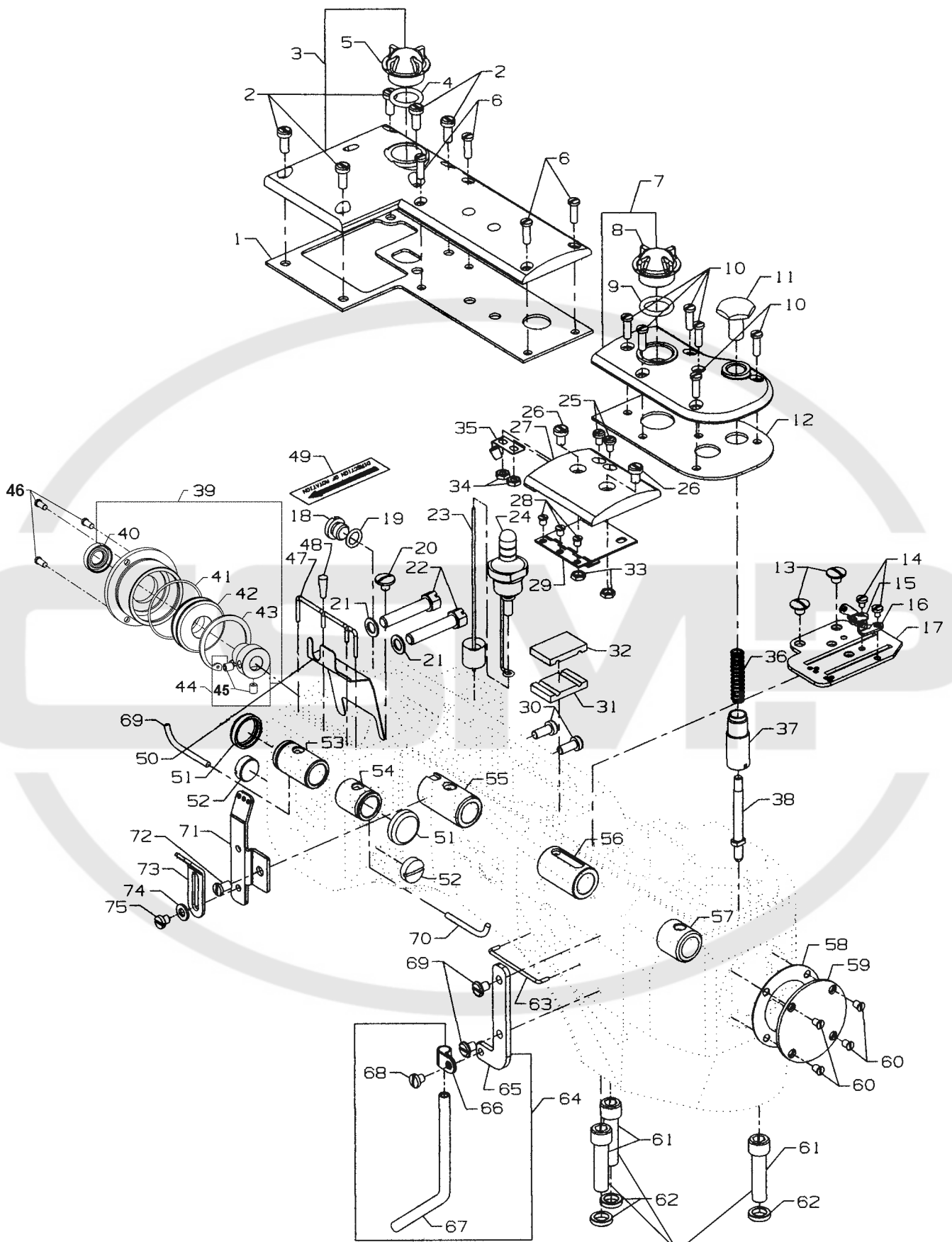

Fig. 27



**Torque to
18 ft. lbs.**



MAIN FRAME, CAST-OFF PLATE, EYELETS, MISCELLANEOUS COVERS AND BUSHINGS

Ref. No.	Part No.	Description	Amt. Req.
1.	35888T	Gasket	1
2.	93	Screw	5
3.	35888N	Crank Chamber Cover	1
4.	660-212	"O" Ring	1
5.	B3530555000	Oil Sight Gauge	1
6.	22516A	Screw	4
7.	35887AE	Top Cover, front	1
8.	B3530555000	Oil Sight Gauge	1
9.	660-212	"O" Ring	1
10.	22516A	Screw	6
11.	35853Z	Looper Throw-Out Plunger Knob	1
12.	35887AG	Gasket	1
13.	22730	Screw	2
14.	73A	Screw	2
15.	35772S	Cast-Off Plate Eyelet, rear	1
16.	35772T	Cast-Off Plate Eyelet, front	1
17.	36204B	Cast-Off Plate	1
18.	22733B	Oil Drain Screw	1
19.	660-206	"O" Ring	1
20.	22711	Screw, for oil wick	1
21.	6042A	Washer	2
22.	22759A	Screw	2
23.	36293F	Oil Sight Gauge Indicator Assembly	1
24.	36293B	Oil Sight Gauge	1
25.	90	Screw	2
26.	93A	Screw	2
27.	35887X	Top Cover, middle	1
28.	22564B	Screw	3
29.	35887R	Middle Top Cover Hinge	1
30.	93	Screw, for rotary pump housing	2
31.	35893H	Seal, Lower	1
32.	35893G	Seal, Upper	1
33.	12934A	Nut	2
34.	41071G	Nut	2
35.	35887M	Spring, top cover	1
36.	35853Y	Looper Throw-Out Plunger Spring	1
37.	35853AA	Looper Throw-Out Bushing	1
38.	35853W	Looper Throw-Out Plunger	1

39. thru 75. See following page.



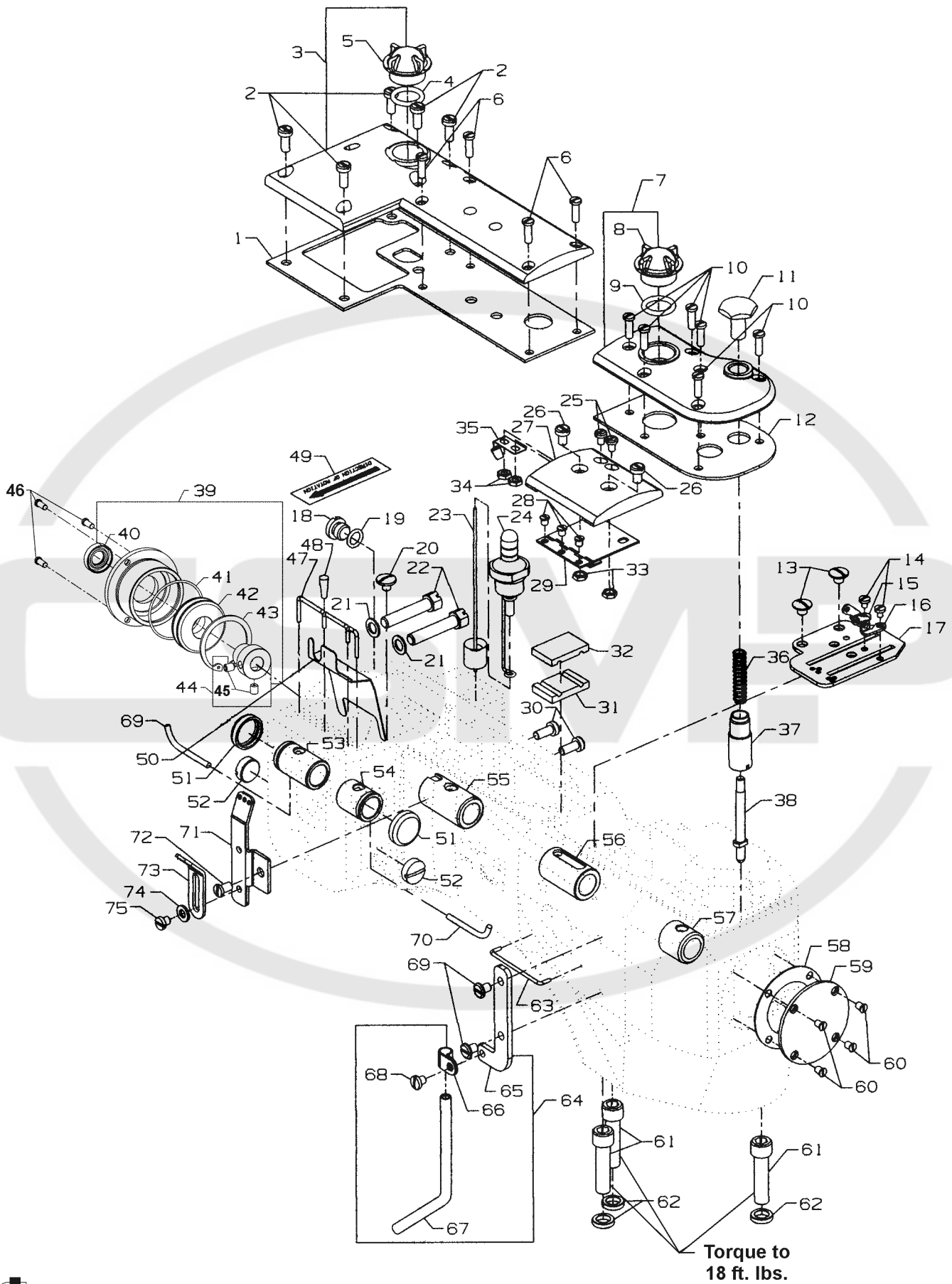

MAIN FRAME, CAST-OFF PLATE, EYELETS, MISCELLANEOUS COVERS AND BUSHINGS (CONT.)

Ref. No.	Part No.	Description	Amt. Req.
1. thru 38. See preceding page.			
39.	35890R	Bearing Housing Assembly	1
40.	660-764	Lip Seal	1
41.	660-935	"O"Ring	1
42.	50311C	Bearing	1
43.	661-348	Retaining Ring	1
44.	36244D	Adaptor Bearing	1
45.	22894F	Screw	2
46.	22569B	Screw	3
47.	CL21	Oil Wick	1
48.	C067E	Cork	1
49.	LA527	Directional Label	1
50.	35889H	Oil Shield	1
51.	35761D	Bushing Cap, plastic	2
52.	22539T	Plug Screw	2
53.	35860E	Needle Lever Shaft Bushing, rear	1
54.	35860D	Needle Lever Shaft Bushing, front	1
55.	35890E	Crankshaft Bushing, front	1
56.	35890Q	Mainshaft Bushing, rear	1
57.	36290B	Mainshaft Bushing, front	1
58.	35887AF	Gasket	1
59.	35887Z	Mainframe End Cover	1
60.	22766	Screw	4
61.	22653E-24	Screw	3
62.	35876U	Washer	3
63.	35781D	Looper Thread Guide Wire	1
64.	29105BH	Looper Thread Tube Assembly, for differential feed	1
-	29105BL	Looper Thread Tube Assembly, for plain feed (not shown)	1
65.	35883AL	Support	1
66.	35866B	Clamp, tube	1
67.	35866A	Tube, for differential feed	1
-	35866C	Tube, for plain feed (not shown)	1
68.	SS7110510SP	Screw	1
69.	22829	Screw	2
70.	CL21	Oil Wick	1
71.	35871B	Needle Thread Eyelet, three holes	1
72.	22570A	Screw	1
73.	35871A	Needle Thread Eyelet, three holes	1
74.	8372A	Washer	1
75.	22570	Screw	1



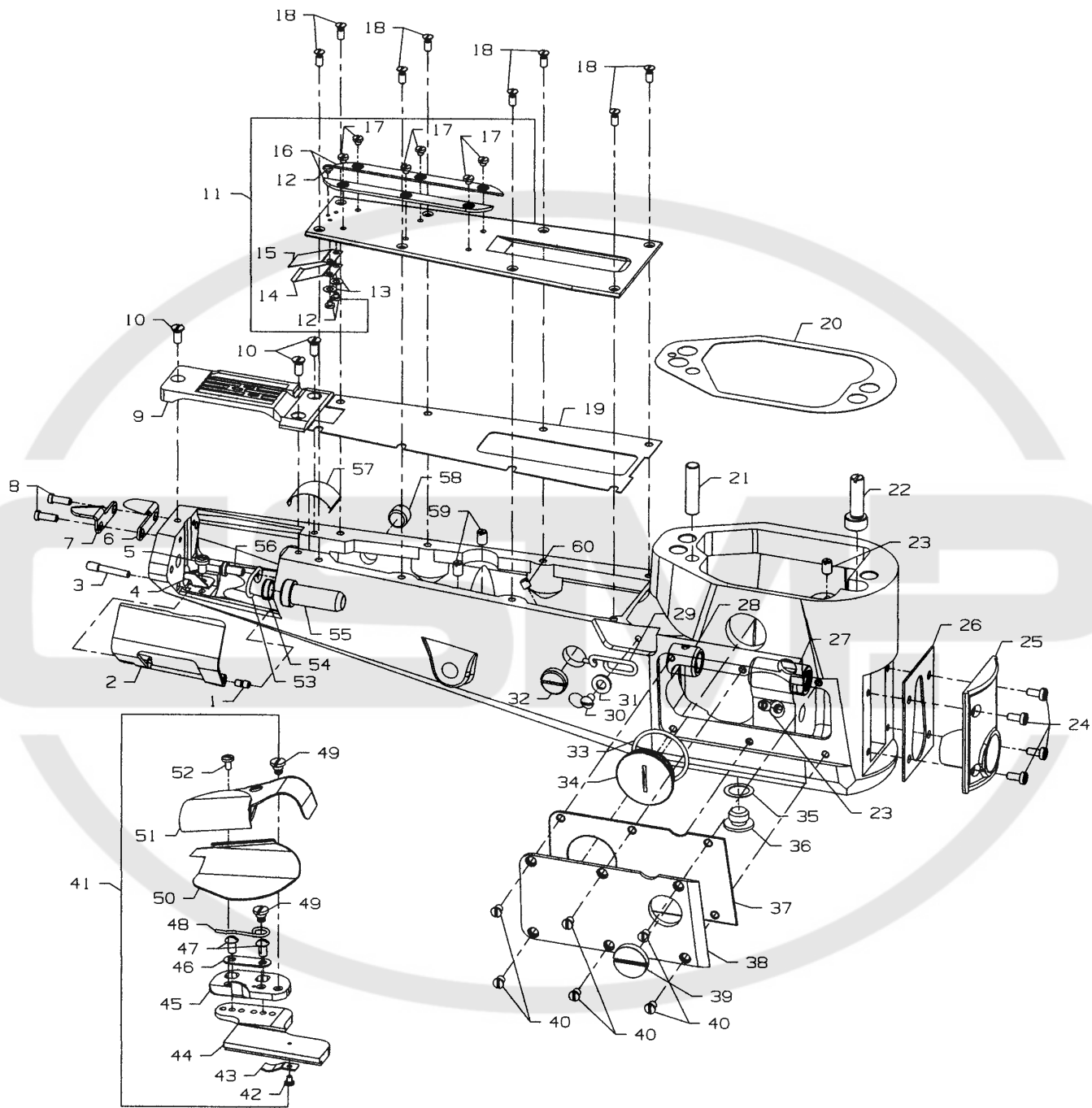

CYLINDER COVERS AND BUSHINGS FOR PLAIN FEED

Ref. No.	Part No.	Description	Amt. Req.
1.	35883G	Pin	1
2.	35883H	Cylinder Hinged Cover	1
3.	22791E	Screw Pin	1
4.	35883E	Spring	1
5.	90	Screw	1
6.	35796C	Chain Cutter Blade, lower	1
7.	35796B	Chain Cutter Blade, upper	1
8.	22747	Screw	2
9.	-----	Throat Plate (see to page 57)	1
10.	22524	Screw, for all throat plates	3
11.	35883A	Cylinder Cover	1
12.	22798	Screw	3
13.	27-435BLK	Washer	2
14.	35884E	Cylinder Lint Shield, upper	1
15.	35884F	Cylinder Lint Shield Spring	1
16.	35883J	Cylinder Cover Adjustable Gib	2
17.	22561A	Screw	6
18.	22526B	Screw	8
19.	36284	Gasket	1
20.	35883M	Gasket	1
21.	667D-16	Dowel Pin, straight	1
22.	36229A1	Eccentric Pin	1
23.	531	Screw	2
24.	J87J	Screw	4
25.	35884H	Cylinder Cover and Oil Gauge	1
26.	35884R	Gasket	1
27.	35850C	Looper Shaft Bushing, front	1
28.	35850B	Looper Shaft Bushing, Middle	1
29.	51758	Looper Thread Eyelet	1
30.	22849A	Screw	1

31. thru 60. See following page.



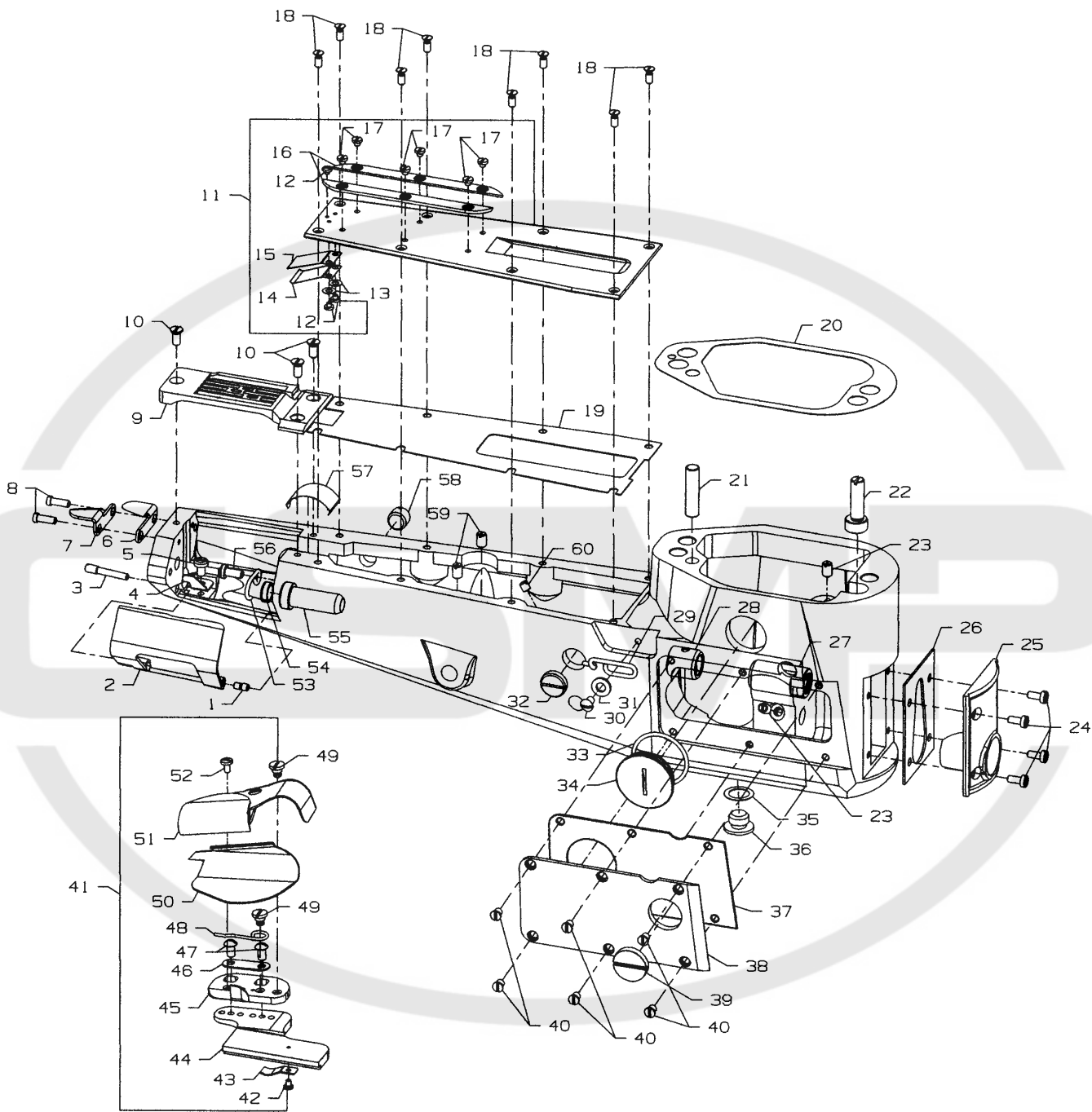

CYLINDER COVERS AND BUSHINGS FOR PLAIN FEED (CONT.)

Ref. No.	Part No.	Description	Amt. Req.
1. thru 30. See preceding page.			
31.	8372A	Washer	1
32.	22539H	Plug Screw	1
33.	660-1115	"O"Ring	1
34.	22539AL	Plug Screw	1
35.	35897AX	Gasket	1
36.	22733A	Oil Drain Plug Screw	1
37.	35886B	Gasket	1
38.	35886C	Cylinder Side Cover	1
39.	22539C	Plug Screw	1
40.	22564B	Screw	6
41.	23420AY18-1/8	Folder Assembly, for all Styles except for machines ending in "L"	1
42.	73A	Screw	1
43.	23424F	Folder Support Spring	1
44.	23424AA	Folder Support Slide	1
45.	23424T	Base	1
46.	23425T	Clamp, for sliding base	1
47.	22849A	Screw	2
48.	23424S	Spring	1
49.	22760A	Screw	2
50.	23422AY18-1/8	Lower Scroll	1
51.	23421Y9-1/8	Upper Scroll	1
52.	87U	Screw	1
53.	36256B	Looper Thread Guide Wire	1
54.	660-1117	Oil Seal for 35850G	1
55.	35850G	Looper Shaft Bushing, rear	1
56.	22849	Screw	1
57.	35884L	Lower Lint Shield	1
58.	22571A	Plug Screw	1
59.	531	Screw, for feed lifter lever shaft	2
60.	88	Screw, for feed rocker shaft	1



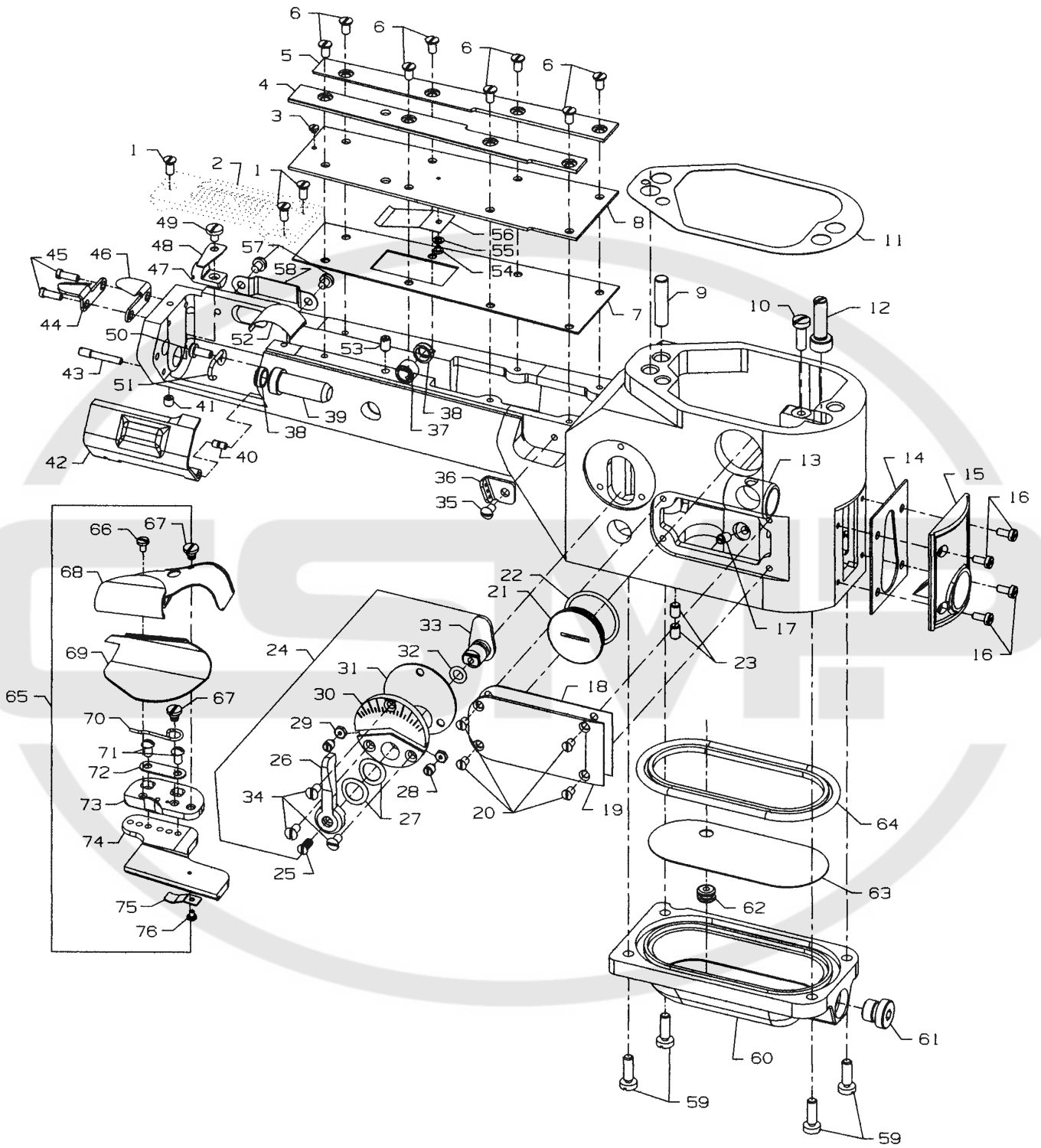

CYLINDER COVERS AND BUSHINGS FOR DIFFERENTIAL FEED

Ref. No.	Part No.	Description	Amt. Req.
1.	22524	Screw	3
2.	-----	Throat Plate (see page 59)	1
3.	22798	Screw	1
4.	35883N	Folder Gib, left	1
5.	35883P	Folder Gib, right	1
6.	22564J	Screw	8
7.	35883AA	Gasket	1
8.	35883T	Cylinder Cover	1
9.	667D-16	Dowel Pin, straight	1
10.	22596	Screw	1
11.	36284	Gasket	1
12.	36229A-1	Eccentric Stud, for Styles 35800BWW, 35800BWWL	1
13.	36249A	Looper Shaft Bushing, front	1
14.	35884R	Gasket	1
15.	36284C	Cylinder Cover and Oil Gauge, front	1
16.	J87J	Screw	4
17.	22560A	Screw	1
18.	36286B	Gasket	1
19.	36286	Cylinder Side Cover	1
20.	22766	Screw	4
21.	22539AL	Plug Screw	1
22.	660-1115	"O" Ring	1
23.	531	Screw	2
24.	29478CZ	Differential Feed Control Assembly	1
25.	538	Screw	1
26.	36237K	Operating Lever	1
27.	36237J	Spring Washer	2
28.	36237H	Stop Screw Pin	2
29.	60078Z	Nut	2
30.	36238	Adjusting Plate	1
31.	36238E	Gasket	1
32.	660-220	Oil Seal Ring	1
33.	36237E	Adjusting Lever	1
34.	87A	Screw	3
35.	22849A	Screw	1
36.	35856Y	Looper Thread Eyelet	1
37.	36237L	Bushing, for feed bar eccentric stud	1

38. thru 76. See following page.



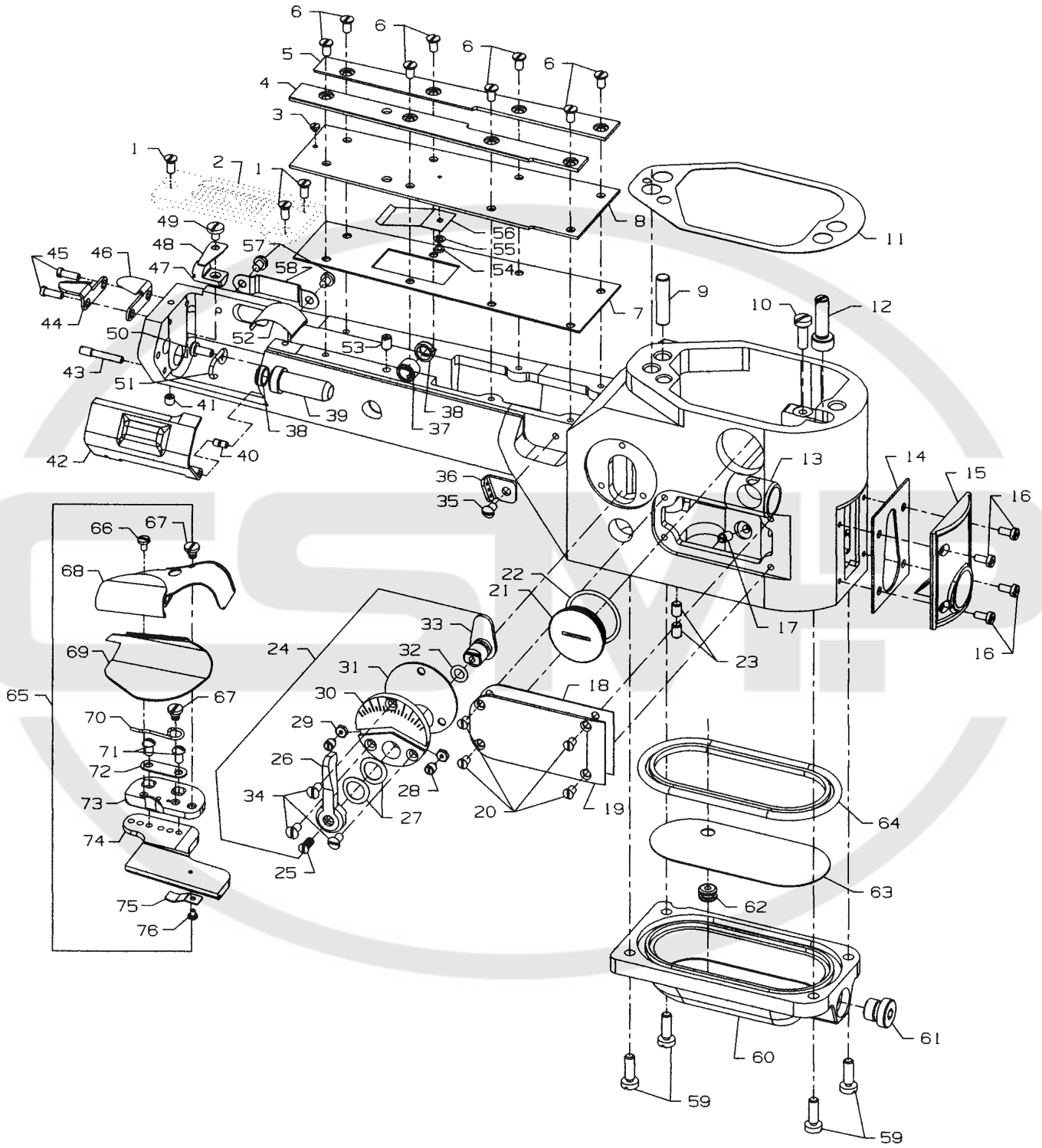

CYLINDER COVERS AND BUSHINGS FOR DIFFERENTIAL FEED (CONT.)

Ref. No.	Part No.	Description	Amt. Req.
1. thru 37. See preceding page.			
38.	660-1117	Oil Seal	2
39.	35850G	Looper Shaft Bushing, rear	1
40.	35883G	Pin	1
41.	22894W	Screw, for cylinder hinge cover spring support stud	1
42.	35883R	Cylinder Hinged Cover	1
43.	22791E	Screw Pin	1
44.	35796B	Chain Cutter Blade, upper	1
45.	22747	Screw	2
46.	35796C	Chain Cutter Blade, lower	1
47.	36283C	Cylinder Hinged Cover Spring Support Stud	1
48.	35883U	Cylinder Cover Spring	1
49.	22585C	Screw	1
50.	22849	Screw	1
51.	36256B	Cylinder Looper Thread Guide Wire	1
52.	35884K	Lower Lint Shield	1
53.	531	Screw	1
54.	22798	Screw	1
55.	27-435BLK	Washer	1
56.	36284E	Upper Lint Shield	1
57.	22513D	Screw	2
58.	35896B	Cylinder Guard, for Looper	1
59.	22596	Screw	4
60.	36282	Bottom Cover	1
61.	999-196	Screw	1
62.	661-150	"O" Ring	1
63.	36293G	Screen	1
64.	36284F	Gasket	1
65.	23420AY18-1/8	Folder Assembly, for all Styles except machines ending in "L"	1
66.	87U	Screw	1
67.	22760A	Screw	2
68.	23421Y9-1/8	Upper Scroll and Base.....	1
69.	23422AY18-1/8	Lower Scroll	1
70.	23424S	Lower Scroll Spring	1
71.	22849A	Screw	2
72.	23425T	Clamp Plate	1
73.	23424T	Base	1
74.	23424AA	Folder Support Slide	1
75.	23424F	Folder Support Spring	1
76.	73A	Screw	1



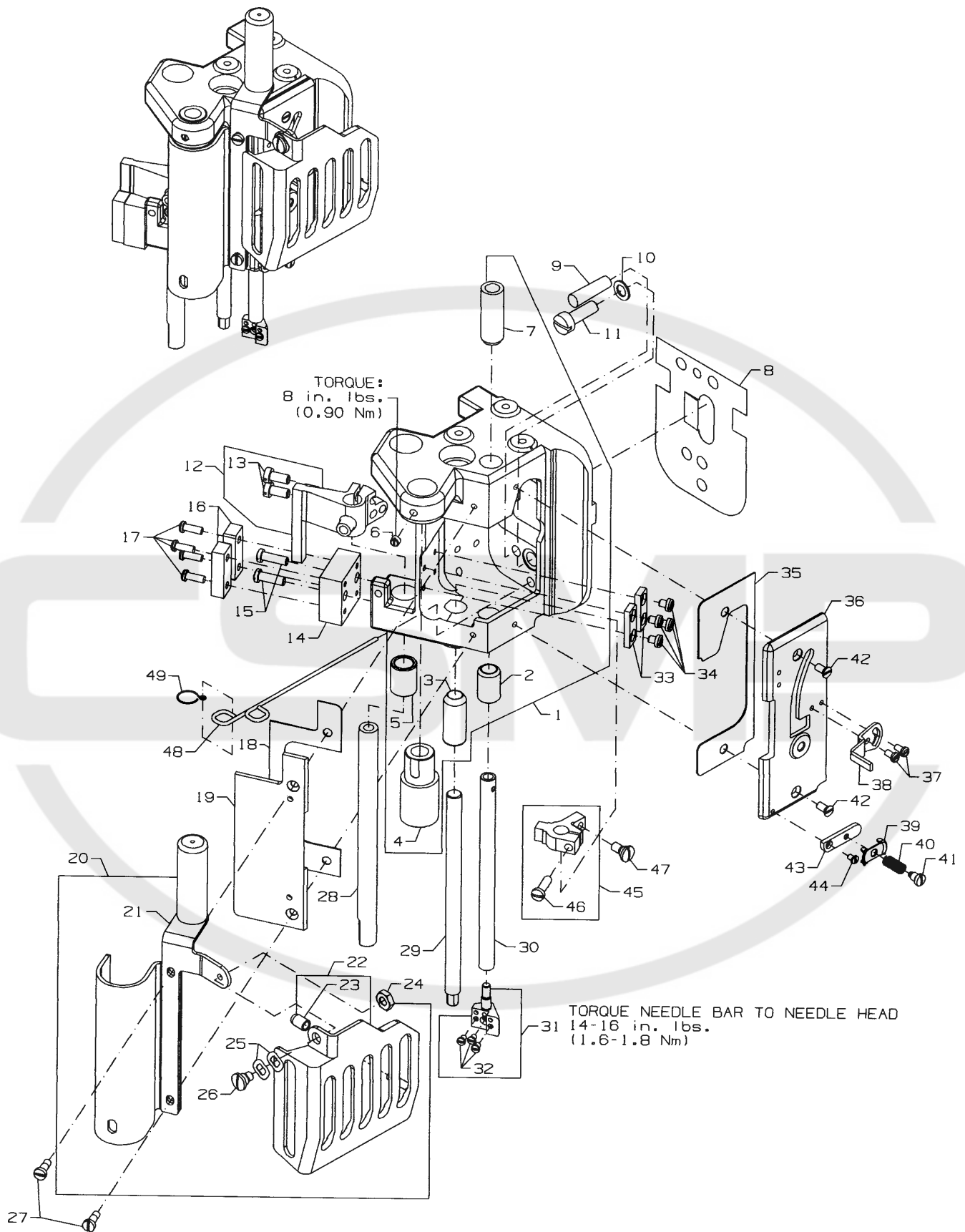

DETACHABLE HEAD ASSEMBLY

Ref. No.	Part No.	Description	Amt. Req.
1.	35829AJ	Detachable Head Assembly	1
2.	35854B	Bushing	1
3.	35844N	Bushing	1
4.	35877AD	Bearing Sleeve Assembly	1
5.	35844T	Bushing	1
6.	SS8120410SP	Set Screw	1
7.	35854A	Bushing	1
8.	35889G	Plate, baffle	1
9.	664F-16	Pin, taper	1
10.	6042A	Washer	1
11.	318	Screw	1
12.	35837P	Guide Finger, rear	1
13.	SS6121010SP	Screw	2
14.	35838B	Block, support, rear guide	1
15.	SS7121410TP	Screw	2
16.	35838A	Plate, guide, roller bar	2
17.	SS4091015SP	Screw	4
18.	35884S	Gasket	1
19.	35882J	Cover, head, left	1
20.	29476YR	Sewing Guard Assembly	1
21.	35882T	Puller Drive Cover Assembly	1
22.	35896D	Sewing Guard	1
23.	666-340A	Bumper Plug	1
24.	9937	Nut	1
25.	WZ0641510KP	Spring Washer	2
26.	22758E	Screw	1
27.	22594	Screw	2
28.	35877AM	Roller Presser Bar	1
29.	35822AE	Presser Bar Air Shaft	1
30.	35817S	Needle Bar	1
31.	35818CB-8	Needle Head for 8 gauge styles	1
-	35818CB-9	Needle Head for 9 gauge styles	1
32.	605	Screw	3
33.	35731A	Plate, guide, presser bar	2
34.	22513D	Screw	4
35.	35884T	Gasket	1
36.	35882K	Cover, head, front	1
37.	22768	Screw	2
38.	35870	Take-Up, needle thread	1
39.	57WB	Nipper Plate, needle thread	1
40.	15438C	Spring	1
41.	57WD	Screw	1
42.	22524	Screw	2
43.	43296	Needle Thread Nipper Base	1
44.	605	Screw	1
45.	35843D	Presser Bar Lift Clamp	1
46.	SS7111410TP	Screw	1
47.	SD0640241SP	Screw	1
48.	WO3	Yarn	1
49.	35897CK	Oil Wick Hook	1



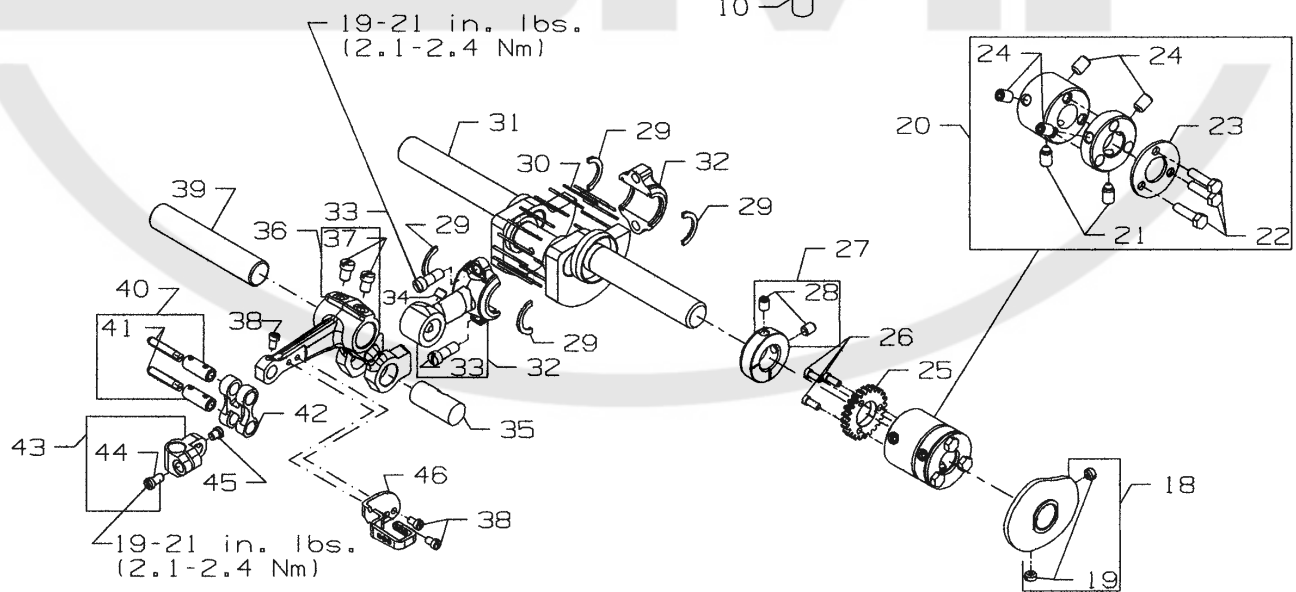
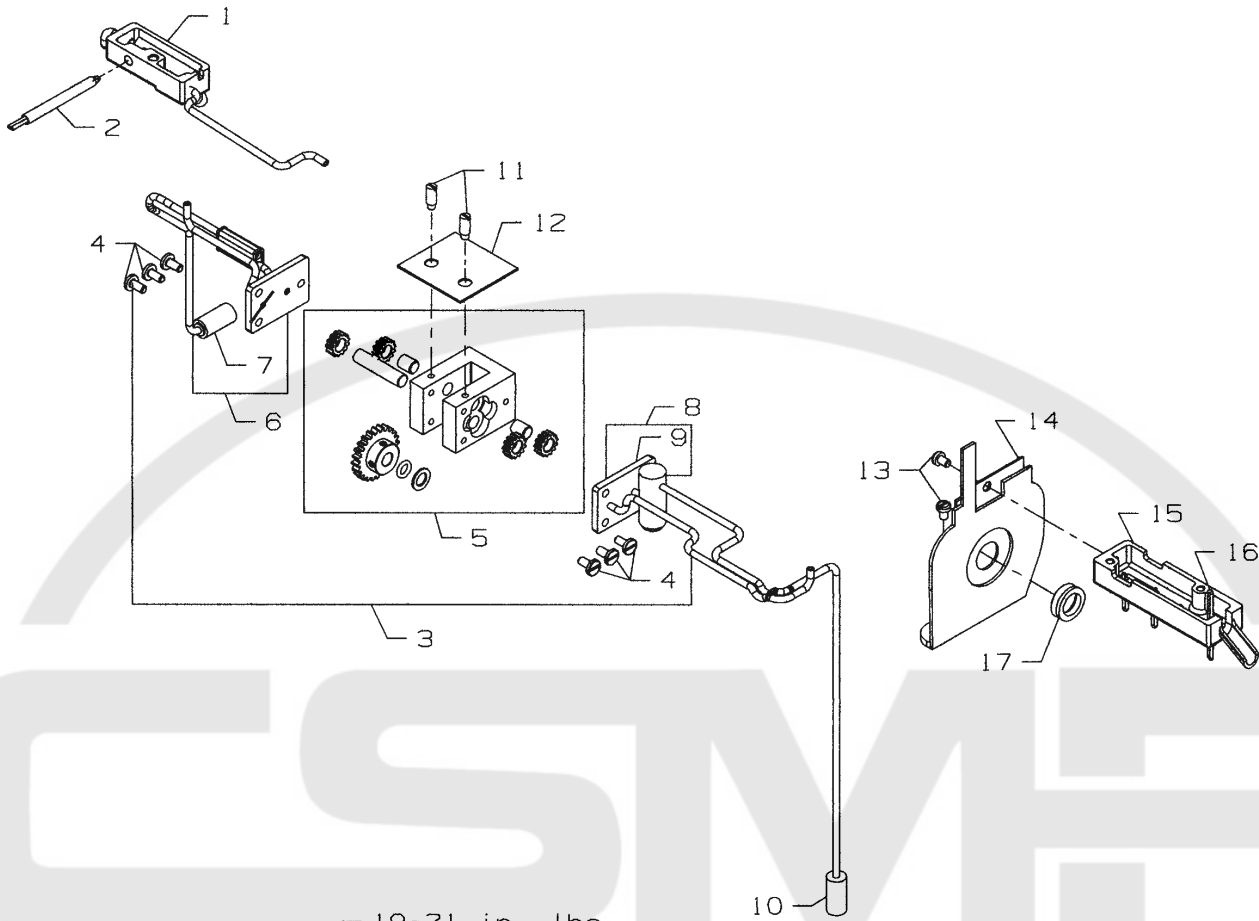

OILING, NEEDLE LEVER, CRANKSHAFT AND MAIN SHAFT PARTS
FOR PLAIN FEED

Ref. No.	Part No.	Description	Amt. Req.
1.	35894V	Oil Reservoir Cover, back	1
2.	35897BU	Oil Reservoir Outlet Tube	1
3.	29472AA	Oil Pump Assembly	1
4.	22585A	Screw	6
5.	29472AC	Oil Pump Assembly	1
6.	35897CC	Oil Pump Assembly Cover, rear	1
7.	35897BV	Intake Filter	1
8.	35897BM	Oil Pump Housing Cover, front	1
9.	22571B	Plug Screw	1
10.	35897BV	Intake Filter	1
11.	21756G	Vent Screw, for oil pump	2
12.	35897BW	Gasket	1
13.	90	Screw	2
14.	36261A	Take-Up Shield	1
15.	35894K	Oil Reservoir, front	1
16.	WO3	Oil Wick	1
17.	666-338	Oil Seal	1
18.	35723C	Looper Thread Take-Up	1
19.	22580D	Screw	2
20.	35895W	Mainshaft and Crankshaft Coupling	1
21.	22894K	Spot Screw	2
22.	22519F	Screw	3
23.	35895Z	Washer Plate	1
24.	22894J	Set Screw	4
25.	35897BY	Oil Pump Driving Gear	1
26.	22797	Screw	3
27.	35895Y	Collar	1
28.	22894AM	Screw	2
29.	35763G	Needle Bearing Retainer	4
30.	35763F	Needle Bearing	28
31.	35822W	Crankshaft	1
32.	35862A	Needle Lever Connecting Rod	1
33.	22587B	Screw	2
34.	22894AM	Screw	1
35.	35847X	Needle Lever Connecting Rod Pin	1
36.	35815C	Needle Lever	1
37.	22596B	Screw	2
38.	77	Screw	1
39.	35761	Needle Lever Shaft	1
40.	51054A	Link Pin	2
41.	666-149	Oil Wick	2
42.	56354D	Needle Lever Link	1
43.	35816	Needle Bar Connection	1
44.	SS7111120TP	Screw	1
45.	22564	Screw	1
46.	35864F	Needle Lever Thread Eyelet	1



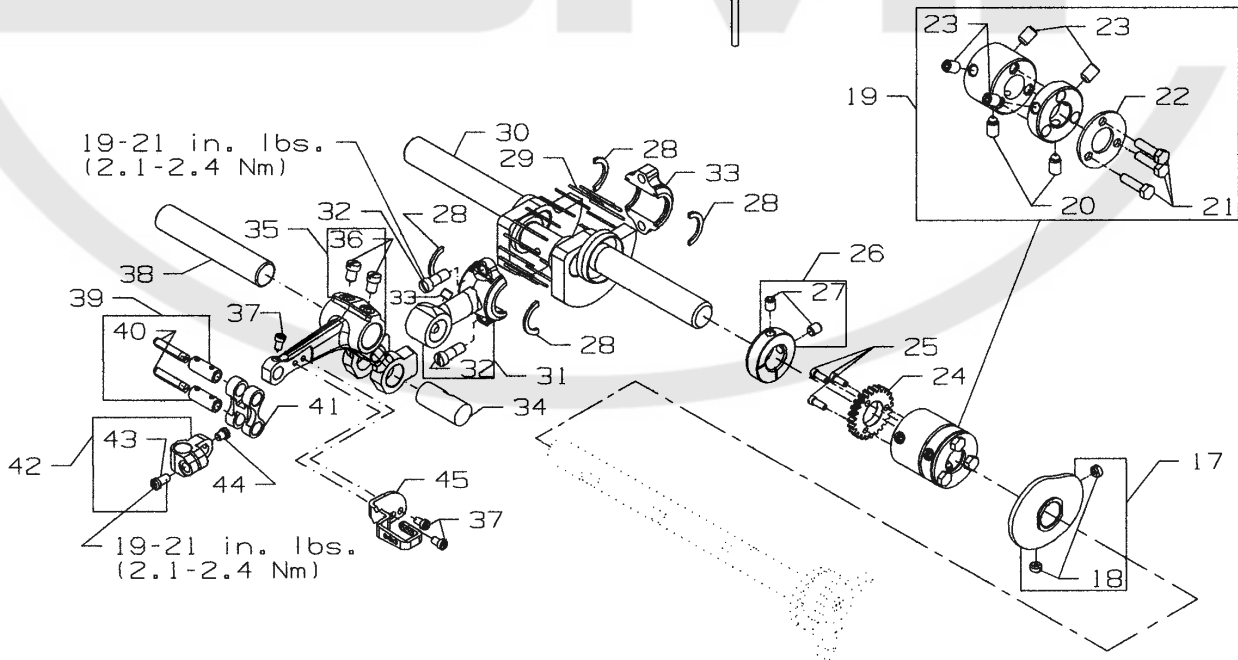
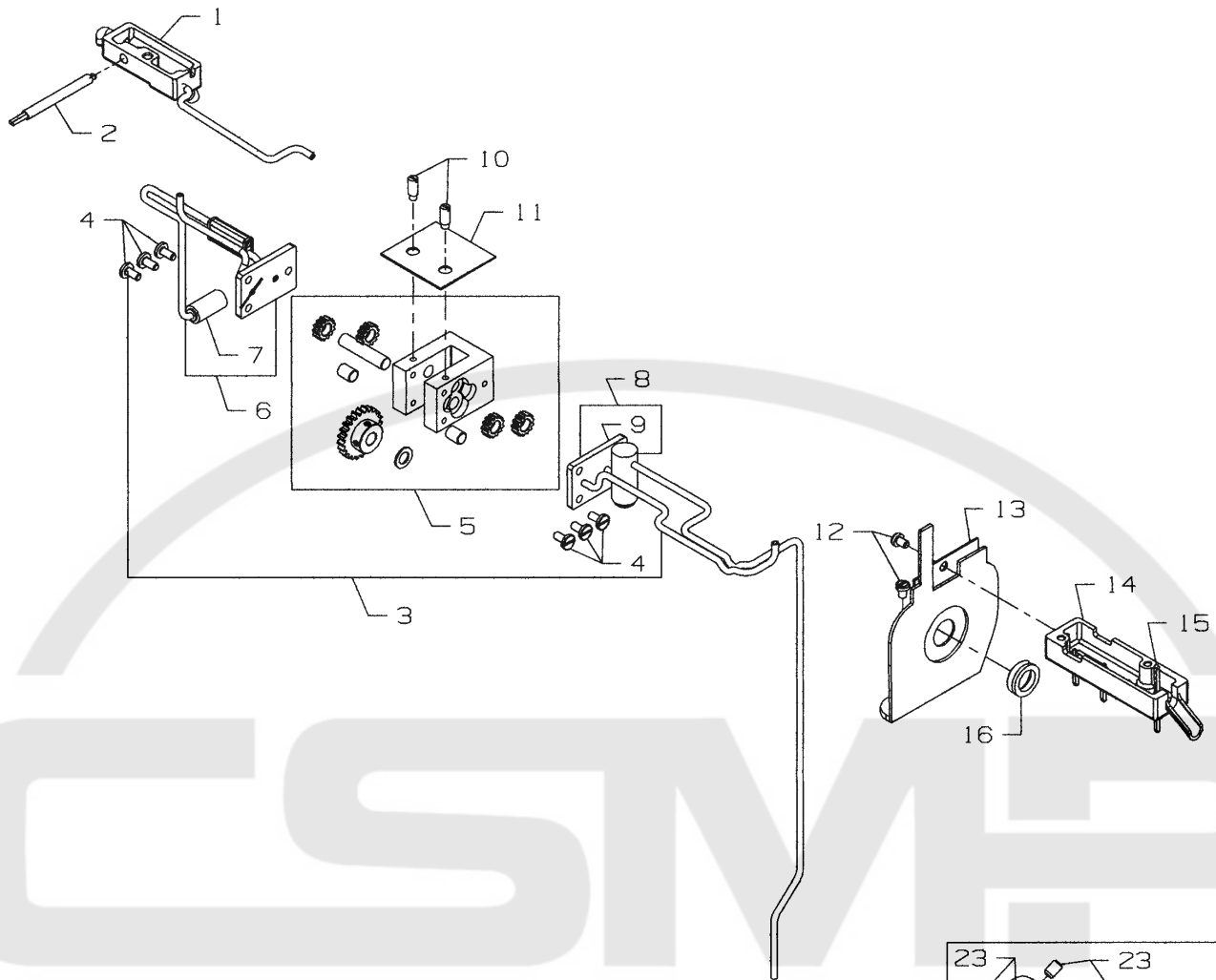

OILING, NEEDLE LEVER, CRANKSHAFT AND MAIN SHAFT PARTS
FOR DIFFERENTIAL FEED

Ref. No.	Part No.	Description	Amt. Req.
1.	35894V	Oil Reservoir Cover, back	1
2.	35897BU	Oil Reservoir Outlet Tube	1
3.	29472AD	Oil Pump Assembly	1
4.	22585A	Screw	6
5.	29472AC	Oil Pump Assembly	1
6.	35897CC	Oil Pump Assembly Cover, rear	1
7.	35897BV	Intake Filter	1
8.	35897CH	Oil Pump Housing Cover, front	1
9.	22571B	Plug Screw	1
10.	21756G	Vent Screw, for oil pump	2
11.	35897BW	Gasket	1
12.	90	Screw	2
13.	36261A	Take-Up Shield	1
14.	35894K	Oil Reservoir, front	1
15.	WO3	Oil Wick	1
16.	666-338	Oil Seal	1
17.	35723C	Looper Thread Take-Up	1
18.	22580D	Screw	2
19.	35895W	Mainshaft and Crankshaft Coupling	1
20.	22894K	Spot Screw	2
21.	22519F	Screw	3
22.	35895Z	Washer Plate	1
23.	22894J	Set Screw	4
24.	35897BY	Oil Pump Driving Gear	1
25.	22797	Screw	3
26.	35895Y	Collar	1
27.	22894AM	Screw	2
28.	35763G	Needle Bearing Retainer	4
29.	35763F	Needle Bearing	28
30.	35822W	Crankshaft	1
31.	35862A	Needle Lever Connecting Rod	1
32.	22587B	Screw	2
33.	22894W	Screw	1
34.	35847X	Needle Lever Connecting Rod Pin	1
35.	35815C	Needle Lever	1
36.	22596B	Screw	2
37.	77	Screw	1
38.	35761	Needle Lever Shaft	1
39.	51054A	Link Pin	2
40.	666-149	Oil Wick	2
41.	56354D	Needle Lever Link	1
42.	35816	Needle Bar Connection	1
43.	SS7110910TP	Screw	1
44.	22564	Screw	1
45.	35864F	Needle Lever Thread Eyelet	1



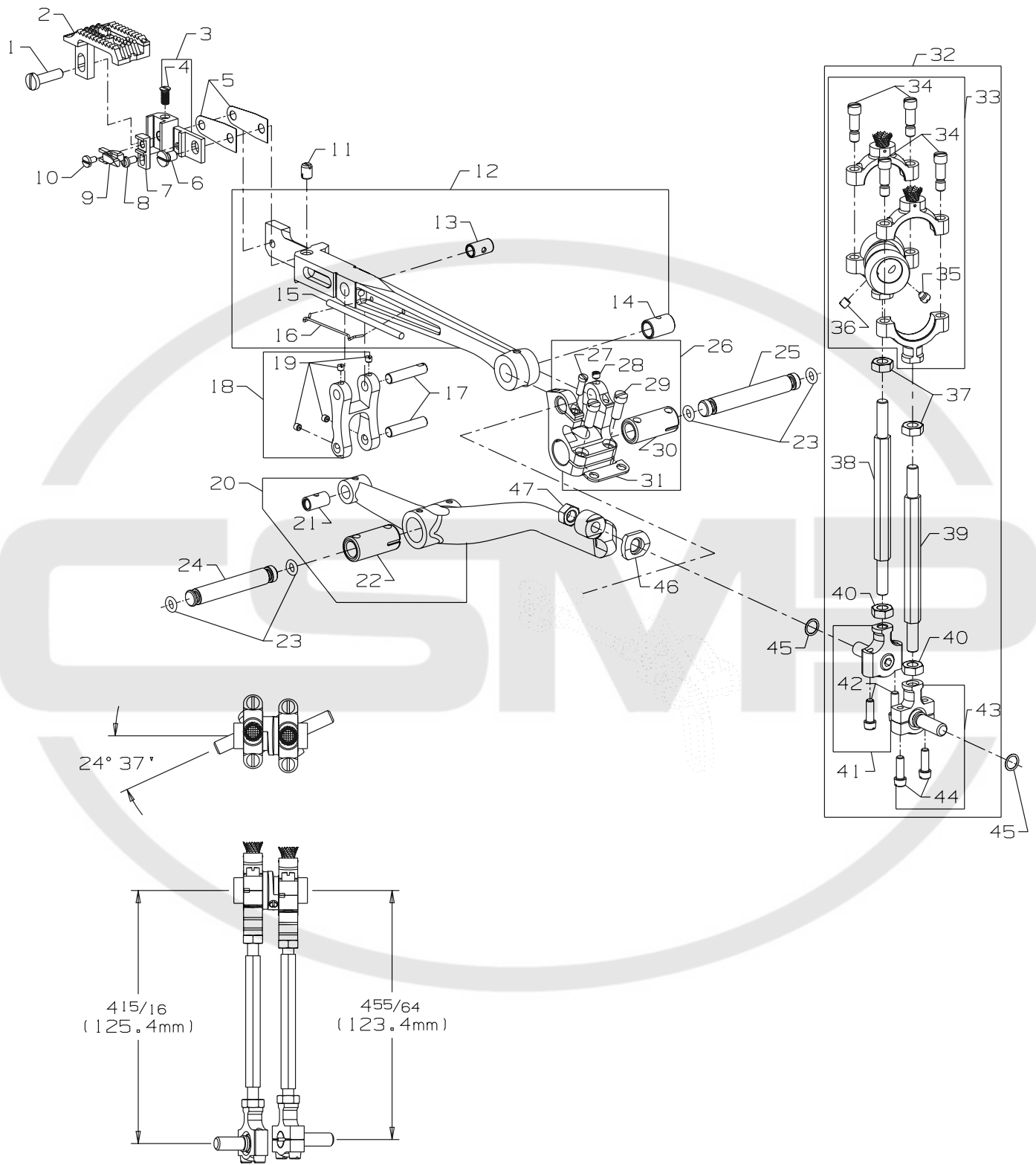

PLAIN FEED BAR, FEED LIFT & FEED DRIVE COMPONENTS
FOR PLAIN FEED

Ref. No.	Part No.	Description	Amt. Req.
1.	22874C	Screw	1
2.	-----	Feed Dog (see page 57)	1
3.	35834U	Feed Dog Holder	1
4.	538	Screw, for adjusting feed dog height	1
5.	35834V3	Feed Dog Holder Shim	2
6.	376	Screw	1
7.	35835B	Needle Guard Holder	1
8.	22768	Screw	1
9.	35825AC	Needle Guard	1
10.	87U	Screw, for needle guard	1
11.	22580A	Feed Dog Support Screw	1
12.	35834R	Feed Bar	1
13.	35834N	Bushing	1
14.	35834G	Bushing	1
15.	666-47	Oil Wicking	1
16.	660-548	Wire Spring Clip	1
17.	35844Z	Link Pin	2
18.	35844Y	Link	1
19.	SS8080310TP	Screw	4
20.	35844	Feed Lifter Lever	1
21.	35844C	Bushing	1
22.	35736A	Bushing	1
23.	660-221	"O" Ring	4
24.	35845D	Feed Lift Lever Shaft	1
25.	35843B	Feed Rocker Shaft	1
26.	35836	Feed Rocker	1
27.	22747	Screw	1
28.	22743	Screw	1
29.	22572	Screw	2
30.	35736A	Feed Rocker Bushing	1
31.	35736B	Feed Rocker Bushing Key	1
32.	29478BD	Connecting Rod Assembly	1
33.	22587E	Screw	4
34.	29101G	Avoid Eccentric	1
35.	22764	Spot Screw	1
36.	88	Screw	1
37.	269	Nut, left thread	2
38.	35847E	Feed Lift Eccentric Connecting Rod	1
39.	43246	Feed Rocker and Loper Avoid Eccentric Connecting Rod	1
40.	18	Nut, right thread	2
41.	35846	Ball Joint	1
42.	22729C	Screw	2
43.	35841B	Ball Joint	1
44.	22729C	Screw	2
45.	41355U	Shim	as required
46.	35846B	Washer	1
47.	258	Nut	1



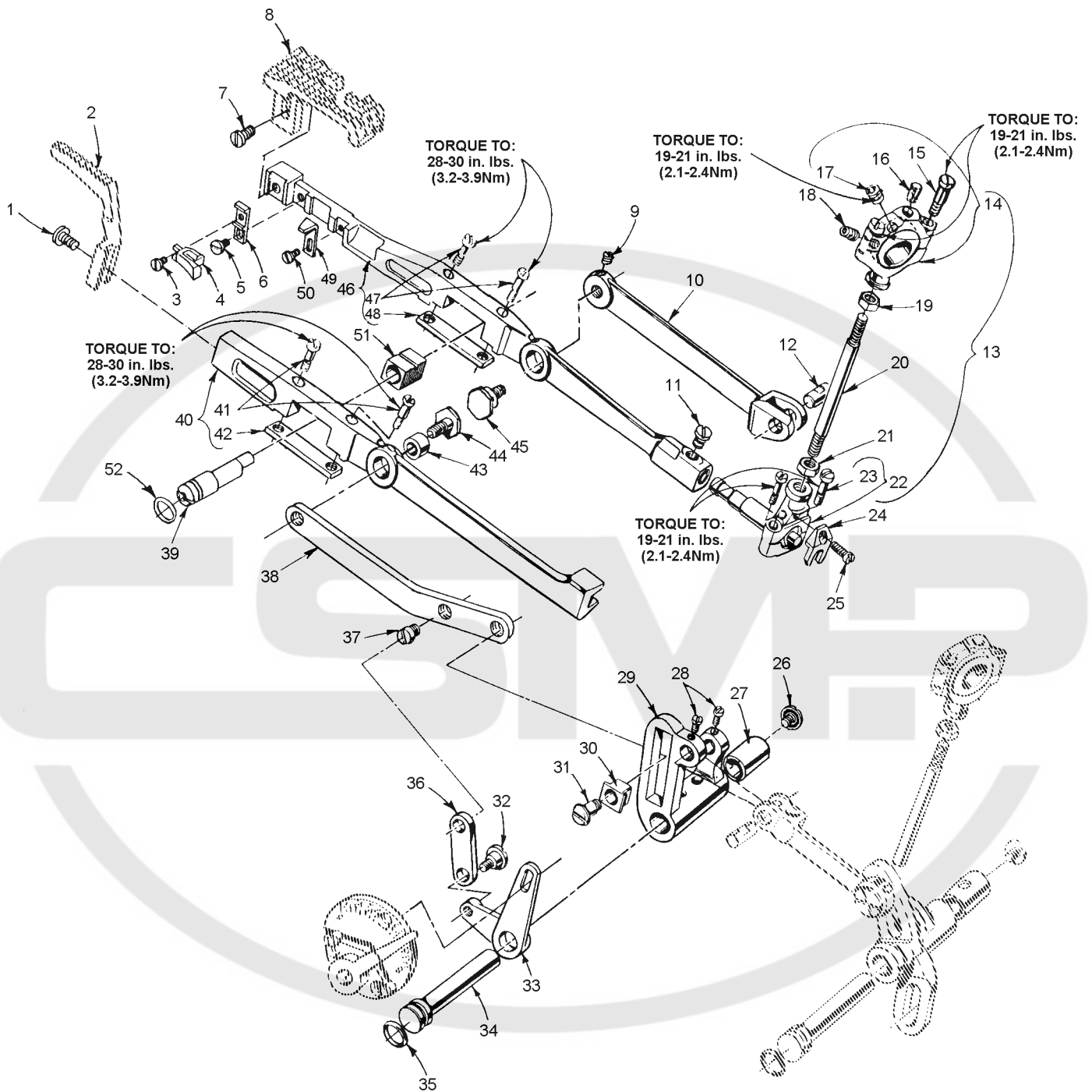

P181-94



DIFFERENTIAL FEED BAR, MAIN FEED BAR, FEED LIFT ECCENTRIC ASSEMBLY
FOR DIFFERENTIAL FEED

Ref. No.	Part No.	Description	Amt. Req.
1.	22528	Screw	1
2.	-----	Differential Feed Dog (see page 59)	1
3.	87U	Screw	1
4.	35825AC	Needle Guard	1
5.	22768	Screw	1
6.	35835B	Needle Guard Holder	1
7.	22528	Screw	1
8.	-----	Main Feed Dog (see page 59)	1
9.	22894P	Screw	1
10.	35834W	Main Feed Bar Driving Link	1
11.	33174B	Screw	1
12.	62238A	Link Pin	1
13.	29478EB	Feed Lift Eccentric Assembly, for Styles 35800BWW, 35800BWWL	1
-	29478DV	Feed Lift Eccentric Assembly, for Style 35800BLW, 35800BWDN	1
14.	29103U	Feed Lift Eccentric Assembly Ball Joint, for Styles 35800BWW, 35800BWWL	1
-	29103T	Feed Lift Eccentric Assembly Ball Joint, for Style 35800BLW 35800BWDN	1
15.	22587E	Screw	2
16.	WO3	Oil Wick	1
17.	22894W	Set Screw	2
18.	22894AA	Spot Screw	1
19.	269	Nut, left thread	1
20.	36244	Connecting Rod	1
21.	18	Nut, right thread	1
22.	36244A	Ball Joint, complete	1
23.	22729C	Screw	2
24.	41255B	Ball Fork	1
25.	22747	Screw	1
26.	22733G	Screw	1
27.	36236L	Bushing, for feed rocker shaft	1
28.	77	Screw	2
29.	35836A	Feed Rocker	1
30.	36236K	Differential Feed Driving Link Slide Block	1
31.	36236J	Differential Feed Bar Driving Link Stud	1
32.	22504C	Screw	1
33.	36237	Differential Feed Adjusting Lever	1
34.	36236A	Feed Rocker Shaft	1
35.	660-207	Oil Seal Ring	1
36.	36237A	Differential Feed Adjusting Lever Link	1
37.	22845M	Screw	1
38.	35836B	Differential Feed Bar Driving Link	1
39.	36234M	Feed Bar Eccentric Stud	1
40.	36234F	Differential Feed Bar	1
41.	22587H	Screw	2
42.	36234G	Feed Bar Plate	1
43.	36236H	Bushing	1
44.	36236G	Differential Feed Bar Driving Link Stud	1
45.	35834X	Main Feed Bar Eccentric Driving Stud	1
46.	35834AB	Main Feed Bar	1
47.	22587H	Screw	2
48.	36234G	Feed Bar Plate	1
49.	35834AC	Main Feed Dog Support	1
50.	22804	Screw	1
51.	36234C	Feed Bar Slide Block	1
52.	660-220	"O" Ring	1



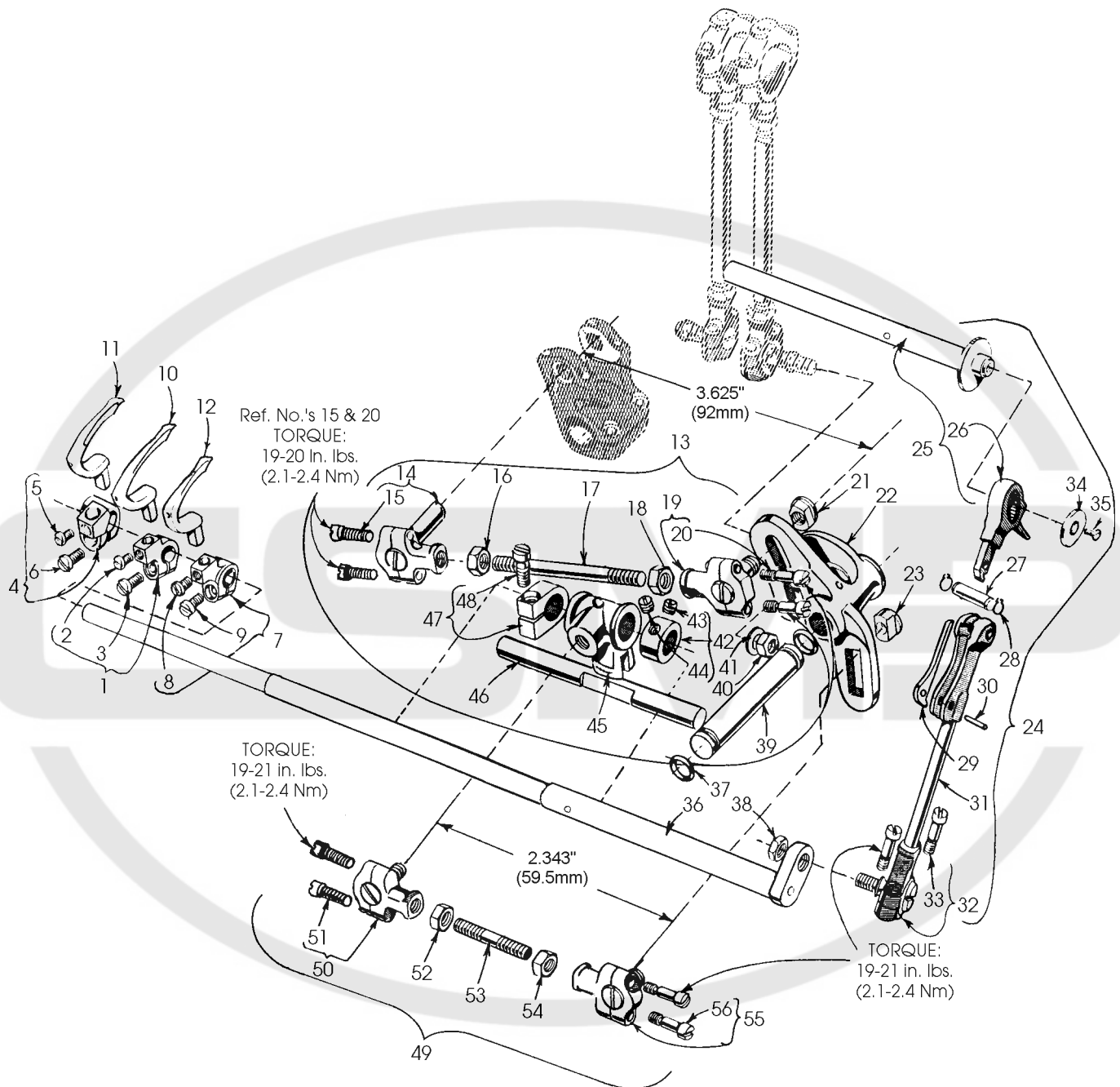

P190-94



FEED DRIVE COMPONENTS, LOOPER DRIVE COMPONENTS AND LOOPERS
FOR PLAIN FEED

Ref. No.	Part No.	Description	Amt. Req.
1.	35848E	Looper Holder, marked "D", for middle looper	1
2.	22564	Screw	1
3.	22562A	Screw	1
4.	35848D	Looper Holder, marked "C", for left looper	1
5.	22564	Screw	1
6.	22562A	Screw	1
7.	35848B	Looper Holder, marked "A", for right looper	1
8.	22564	Screw	1
9.	22562A	Screw	1
10.	35809AY	Looper, marked "AV", for right needle	1
11.	35809BY	Looper, marked "AY", for middle needle	1
12.	35808AY	Looper, marked "AU", for left needle	1
13.	29478AH	Feed Rocker Connecting Rod Assembly	1
14.	35837A	Ball Joint	1
15.	22729C	Screw	2
16.	18	Nut, right thread	1
17.	39141	Connecting Rod	1
18.	269	Nut, left thread	1
19.	35837N	Ball Joint	1
20.	22729C	Screw	2
21.	35866	Nut	1
22.	35842	Feed Rocker and Looper Avoid Lever	1
23.	35766A	Nut	1
24.	29478DZ	Looper Drive Connecting Rod Assembly	1
25.	35722AF	Main Shaft Assembly	1
26.	35853AJ	Looper Drive Connection	1
27.	35853V156	Hinge Pin	1
28.	660-310	Tru-Arc Ring	2
29.	56341G	Locking Spring	1
30.	50-458BLK	Pin	1
31.	35853AK	Looper Drive Connecting Rod	1
32.	35853AD	Ball Joint, looper shaft	1
33.	22729D	Screw	2
34.	35895V	Washer	1
35.	22526	Screw	1
36.	35849B	Looper Rocker Shaft	1
37.	660-220	Oil Seal Ring	2
38.	258A	Nut	1
39.	35842H	Feed Rocker and Looper Lever Shaft	1
40.	258A	Nut	1
41.	6042A	Washer	1
42.	35751F	Looper Shaft Collar	1
43.	88	Screw	1
44.	89	Screw	1
45.	35751	Looper Rocker Shaft Cross Head	1
46.	35751B	Cross Head Guide Shaft	1
47.	35751G	Thrust Collar	1
48.	22752B	Screw	1
49.	29478AJ	Connecting Rod Assembly	1
50.	35851A	Ball Joint	1
51.	22729C	Screw	2
52.	18	Nut, right thread	1
53.	35851G	Connecting Rod	1
54.	269	Nut, left thread	1
55.	35851	Ball Joint	1
56.	22729C	Screw	2



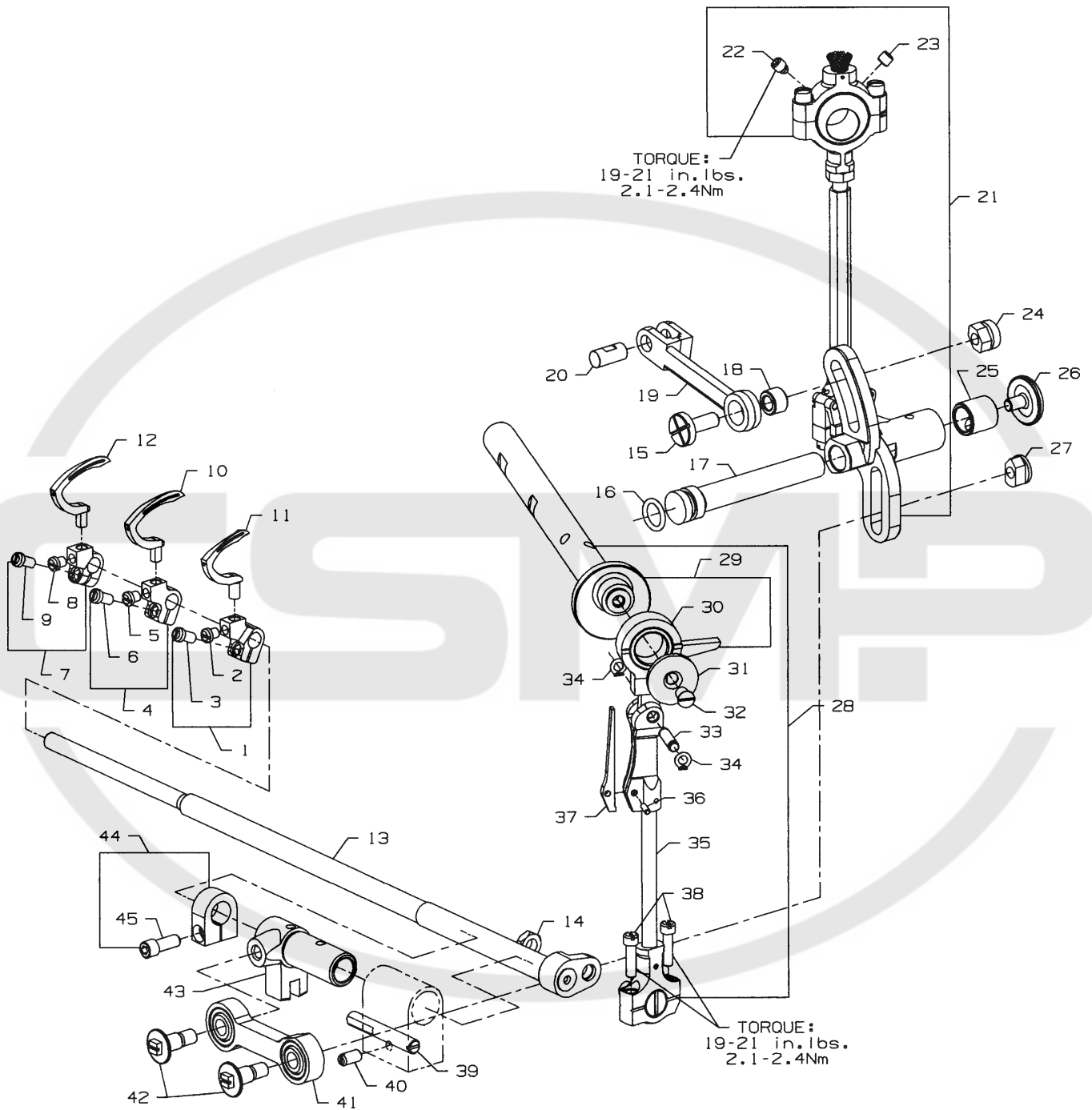

LOOPERS, LOOPER HOLDERS, FEED DRIVE COMPONENTS AND LOOPER AVOID
COMPONENTS FOR DIFFERENTIAL FEED

Ref. No.	Part No.	Description	Amt. Req.
1.	35848B	Looper Holder, marked "A", for right looper	1
2.	22562A	Screw	1
3.	22564	Screw	1
4.	35848E	Looper Holder, marked "D", for middle looper	1
5.	22562A	Screw	1
6.	22564	Screw	1
7.	35848D	Looper Holder, marked "C", for left looper	1
8.	22562A	Screw	1
9.	22564	Screw	1
10.	35809AY	Looper, marked "AV", for right needle	1
11.	35808AY	Looper, marked "AU", for left needle	1
12.	35809BY	Looper, marked "AY", for middle needle	1
13.	35849C	Looper Rocker Shaft	1
14.	258A	Nut	1
15.	35836C	Feed Rocker Driving Link Screw	1
16.	660-207	Oil Seal Ring	1
17.	36236A	Feed Drive Shaft	1
18.	36236H	Bushing, for feed rocker driving link	1
19.	36236C	Feed Rocker Driving Link	1
20.	62238A	Link Pin	1
21.	29478EC	Feed Drive Assembly	1
22.	22894W	Screw	1
23.	22894U	Screw	1
24.	35866	Nut	1
25.	36236B	Bushing	1
26.	22733G	Screw	1
27.	35766B	Nut	1
28.	29478DZ	Looper Drive Connecting Rod Assembly	1
29.	35722AF	Main Shaft Complete	1
30.	35853AJ	Looper Drive Connection	1
31.	35895V	Shaft Stop Washer	1
32.	22526	Screw	1
33.	35853V156	Hinge Pin	1
34.	660-310	Truarc Ring	2
35.	35853AK	Looper Drive Connecting Rod	1
36.	50-458BLK	Pin	1
37.	56341G	Locking Spring	1
38.	22729C	Screw	2
39.	36278C	Stud, for looper shaft sleeve	1
40.	22560A	Screw	1
*41.	35851S	Connecting Rod Bearing Shell	1
*42.	35851P	Screw	2
43.	36249B	Looper Shaft Sleeve	1
44.	35751G	Looper Shaft Collar	1
45.	22572B	Screw	1

*For older style machines these parts
must be purchased as assembly 29478FH



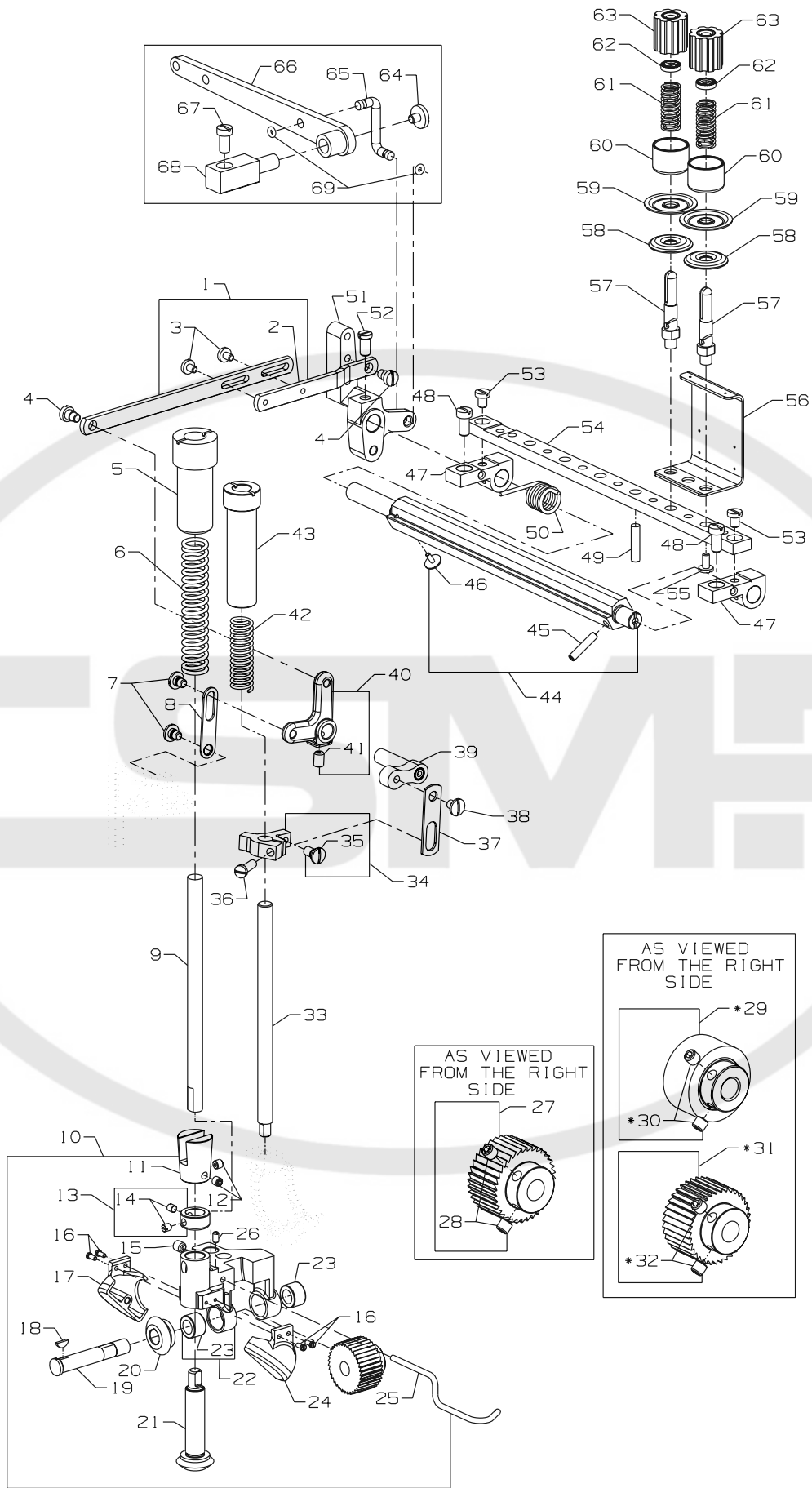

UPPER ROLLER FEED, FOOT LIFTER AND THREAD TENSION PARTS

Ref. No.	Part No.	Description	Amt. Req.
1.	36280V	Lifter Lever Link Assembly	1
2.	36280U	Lifter Lever Link	1
3.	22585C	Screw	2
4.	86	Screw	2
5.	35892A	Puller Bar Knob, rear	1
6.	50377L	Spring, puller bar	1
7.	22758C	Screw	2
8.	35835F	Lifter Lever Bell Crank Link	1
9.	35877AM	Roller Presser Bar	1
10.	29478ED	Puller Assembly for, 35800BLW, 35800BQW, 35800BWW, 35800BWDN, 35800BWDR	1
-	29478EL	Puller Assembly for, 35800BRWH	1
11.	54274C	Feed Roller Lower Connection	1
12.	22894P	Screw	2
13.	14649	Drive Gear Collar	1
14.	88	Screw	2
15.	22894C	Screw	1
16.	22738	Screw	4
17.	35875Z	Gear guard, rear	1
18.	35877AA	Woodruff Key	1
19.	35873AK	Feed Roller Shaft	1
20.	35875X	Driven Miter Gear	1
21.	35875Y	Drive Miter Gear	1
22.	35873AJ	Feed Roller Frame	1
23.	660-303	Needle Bearing	2
24.	35875AA	Gear Guard, front	1
25.	21237ES	Air Blower Tube	1
26.	73C	Screw	1
27.	35826X	Feed Roller	1
28.	22894W	Screw	2
*29.	35826DZ	Wide Rubber Roller For 35800BRWH	1
*30.	22894W	Screw	2
*31.	35826CB	Feed Roller, Same as 35826X but reverse teeth	1
*32.	22894W	Screw	2

33. thru 69. See following page.

*Items can be purchased as an extra send charge.



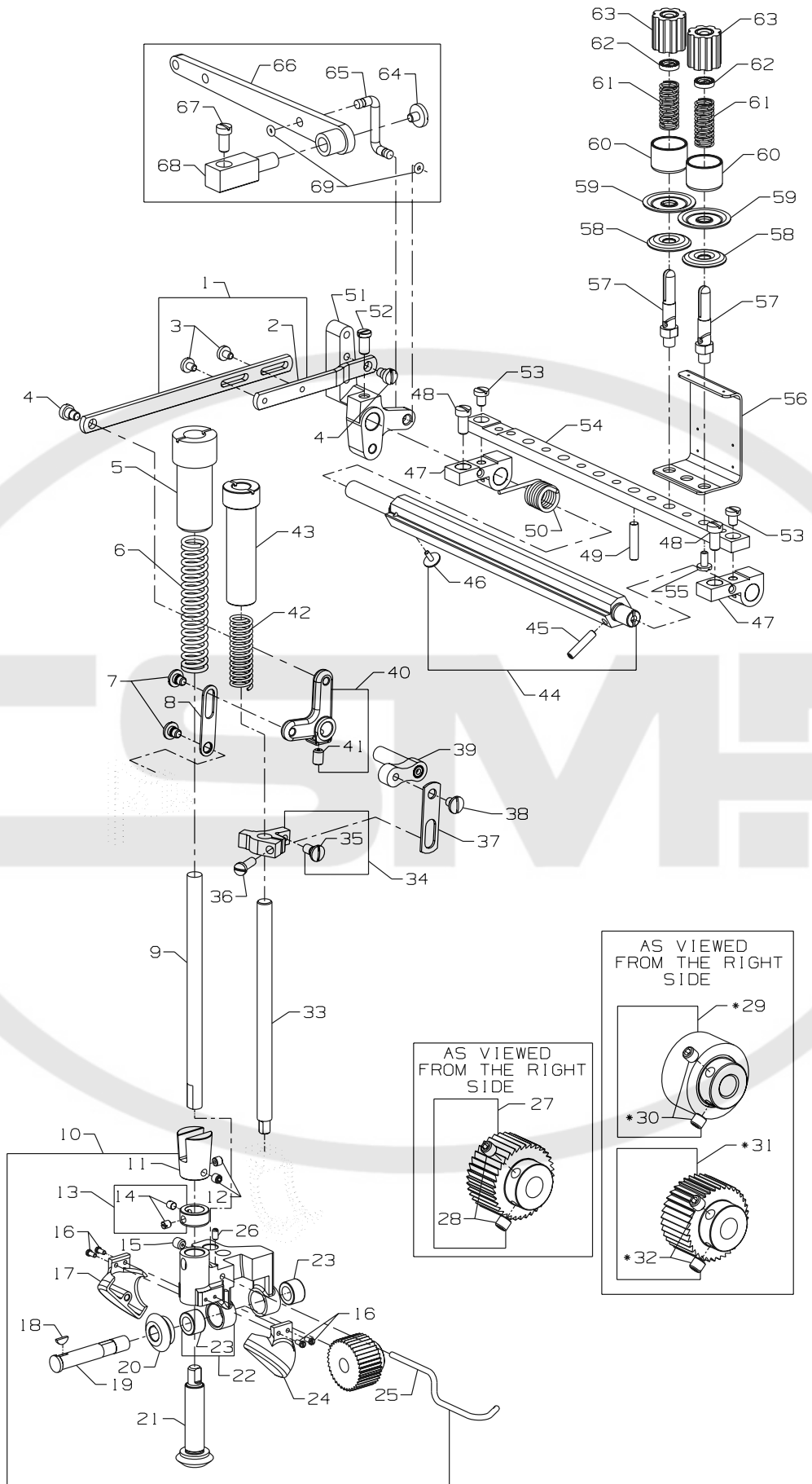

UPPER ROLLER FEED, FOOT LIFTER AND THREAD TENSION PARTS (CONT.)

Ref. No.	Part No.	Description	Amt. Req.
1. thru 32. See preceding page.			
33.	35822AE	Presser Bar	1
34.	35843D	Presser Bar Lifter and Guide	1
35.	SD0640241SP	Screw	1
36.	SS7111410TP	Screw	1
37.	35880L	Lifter Lever Connecting Link	1
38.	22758C	Screw	1
39.	35880N	Presser Bar Lifter Lever	1
40.	35880P	Lifter Lever Bell Crank	1
41.	22894J	Screw	1
42.	35832A	Spring, presser bar	1
43.	35843C	Presser Bar Knob	1
44.	36292N	Tension Release Shaft	1
45.	660-219S	Pin	1
46.	22784F	Screw	1
47.	36292M	Tension Plate Bracket	2
48.	22517	Screw	2
49.	35792T	Tension Disc Release Pin	7
50.	36292K	Tension Release Shaft Spring	1
51.	36280W	Lifter Lever	1
52.	22839D	Screw	1
53.	94	Screw	2
54.	36298H	Tension Support	1
55.	22585A	Screw	6
56.	36298G	Tension Thread Eyelet	3
57.	36292Q	Tension Post	6
58.	109	Tension Disc, small	6
59.	35792	Tension Disc, large	6
60.	W56392F	Shield, tension spring	6
61.	51292F4	Looper Thread Tension Spring, for looper	3
-	51292F14	Needle Thread Tension Spring, for needle	3
62.	39592AK	Tension Post Ferrule	6
63.	WC50092S	Tension Nut	6
64.	255	Screw	1
65.	36280T	Lifter Lever Connecting Link	1
66.	36280S	Presser Foot Connection Lifter Lever	1
67.	22517	Screw, for presser foot lifter bearing bracket	1
68.	36280N	Presser Foot Lifter Bearing Bracket	1
69.	660-254C	Retainer Ring	2



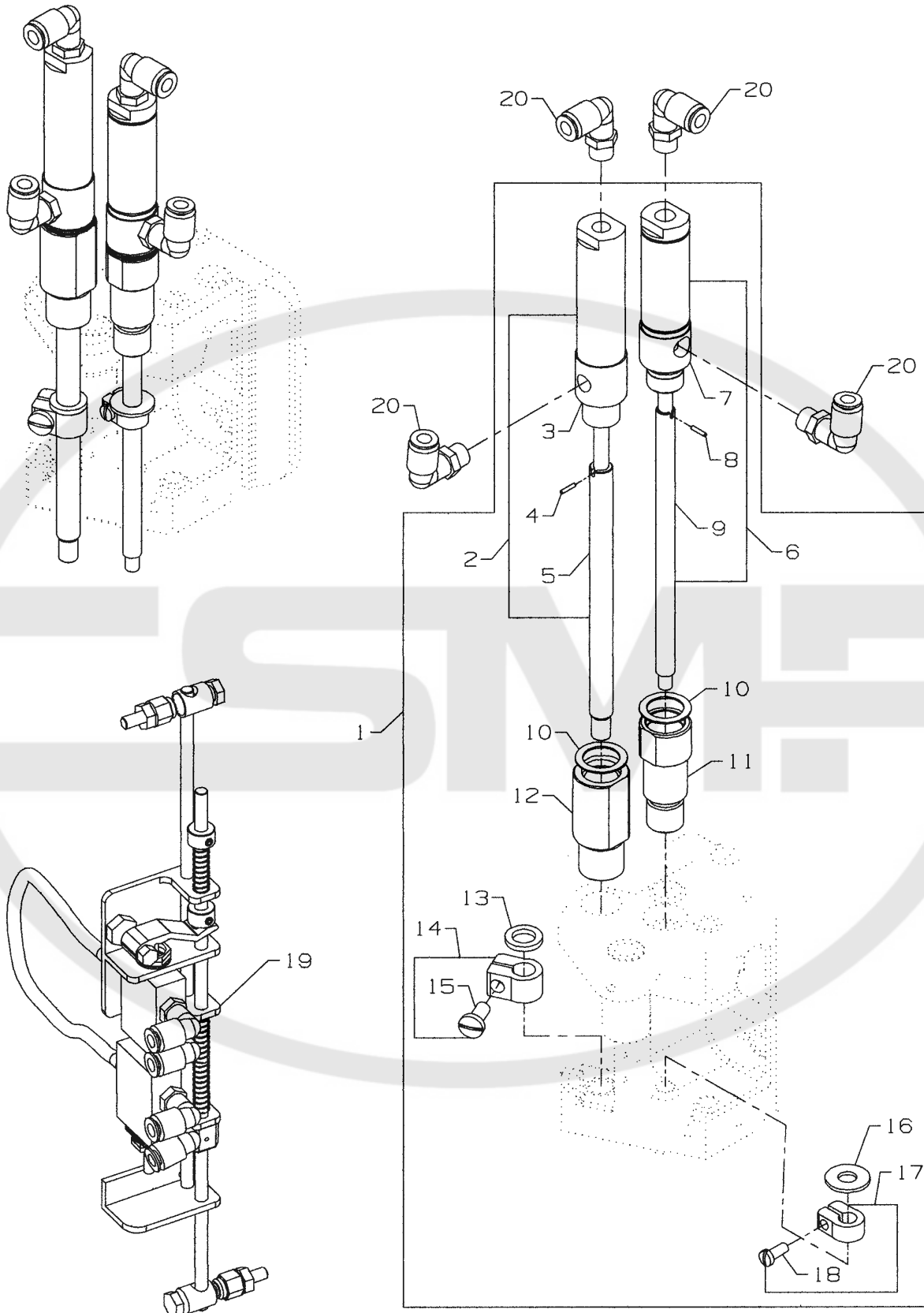

REAR ROLLER & PRESSER FOOT PNEUMATIC COMPONENTS & TREADLE SWITCH

Ref. No.	Part No.	Description	Amt. Req.
1.	29476UE	Pneumatic Assembly Kit	1
2.	29476UD	Puller Shaft Air Cylinder Assembly	1
3.	671A35	Air Cylinder	1
4.	660-219AT	Roll Pin	1
5.	35877AN	Puller Shaft	1
6.	29476TE	Presser Bar Air Assembly	1
7.	671A146-1	Air Cylinder	1
8.	660-219AT	Roll Pin	1
9.	35822AH	Presser Bar Shaft	1
*10.	35886M	Washer, Fiber	1/3
11.	671A256A	Adapter, air cylinder	1
12.	671A254	Adapter, air cylinder	1
13.	35886H	Washer, neoprene	1
14.	35833R	Collar, clamp	1
15.	SS7151310TP	Screw	1
16.	35886J	Washer, neoprene	1
17.	35833S	Collar, clamp	1
18.	SS7111120TP	Screw	1
19.	29476SE	Treadle Switch	1
20.	671F81C	Elbow Fitting	4

*Add washer(s) (Use 0-3 washers Max.) as necessary to position air cylinder properly to avoid air line fitting interference



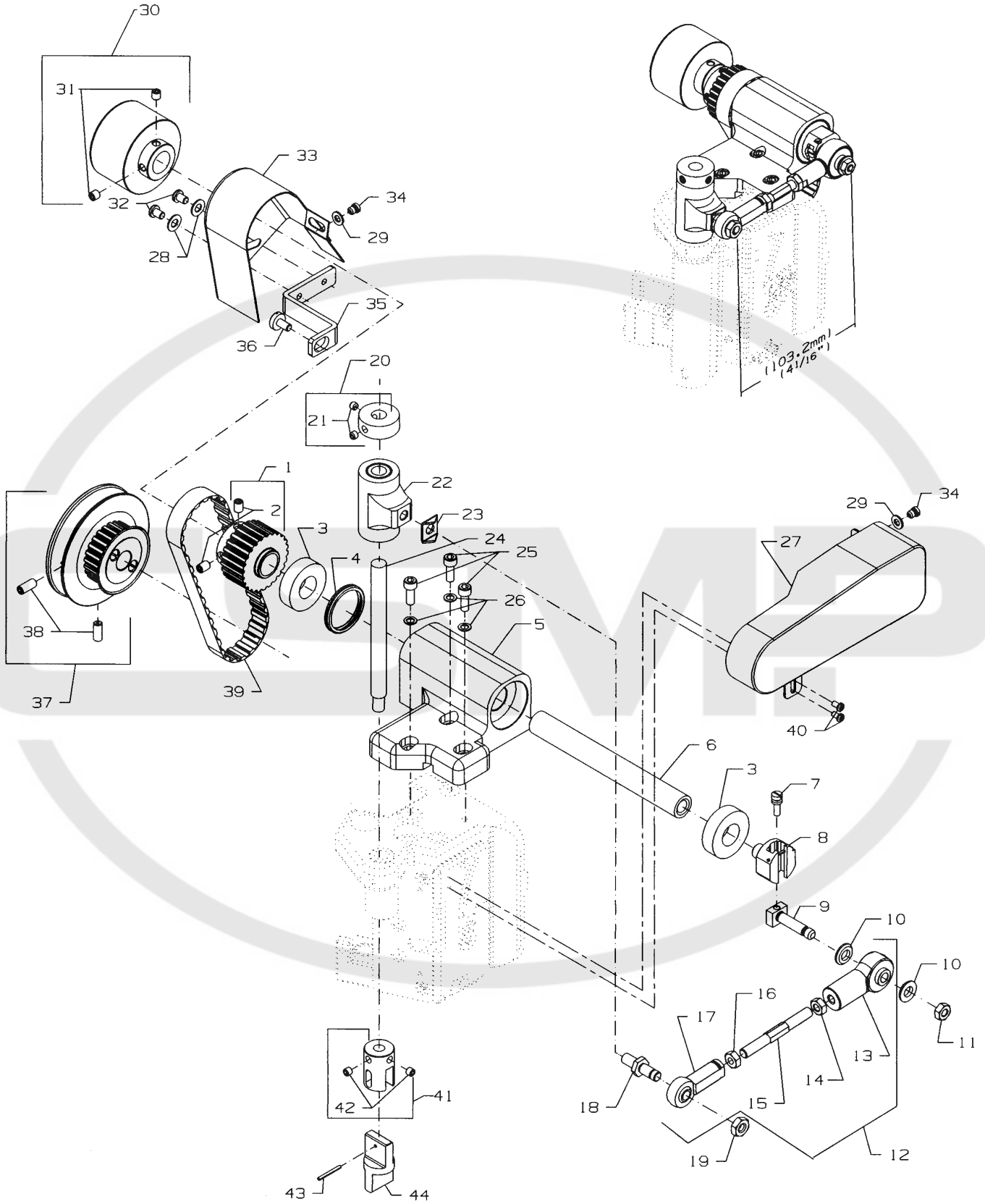

PULLER DRIVE ASSEMBLY

Ref. No.	Part No.	Description	Amt. Req.
1.	35877AB	Upper Sprocket	1
2.	22894J	Set Screw	2
3.	660-974	Bearing	2
4.	660-675	Load Ring	1
5.	35844F	Upper Shaft Housing	1
6.	35874V	Upper Shaft	1
7.	22795	Adjusting Screw	1
8.	34776L	Shaft Head	1
9.	34736L	Crank Stud	1
10.	99622A	Washer	2
11.	18	Nut	1
12.	29476VE	Connecting Rod Assembly	1
13.	35844X	Rod End Bearing	1
14.	35887AK	Nut	1
15.	35845E	Connecting Rod	1
16.	35887AJ	Nut, left handed	1
17.	35844W	Rod End Bearing	1
18.	35837X	Stud	1
19.	35887AK	Nut	1
20.	35877AG	Collar, clutch shaft	1
21.	22894W	Set Screw	2
22.	35877AH	Clutch Shaft Housing	1
23.	35837W	Bearing Guide	1
24.	35877AF	Shaft, clutch	1
25.	22653B12	Screw, upper shaft housing	3
26.	53634C	Washer	3
27.	35882S	Cover, connecting rod	1
28.	20	Washer	2
29.	80040-1	Washer	2
30.	35821T	Handwheel	1
31.	22894C	Screw	2
32.	22569D	Screw, mounting	2
33.	35882F	Cover, puller belt	1
34.	73X	Screw, belt cover	1
35.	35883AX	Bracket	1
36.	SS6120930TP	Screw	1
37.	35821W	Main Shaft Pulley Assembly	1
38.	22894E	Set Screw	2
39.	C50042AG	Timing Belt	1
40.	22768	Screw	2
41.	35876AH	Feed Roller Connection, rear	1
42.	22894P	Screw	2
43.	660-219	Roll Pin	1
44.	54279	Feed Roller Drive Floating Connection	1



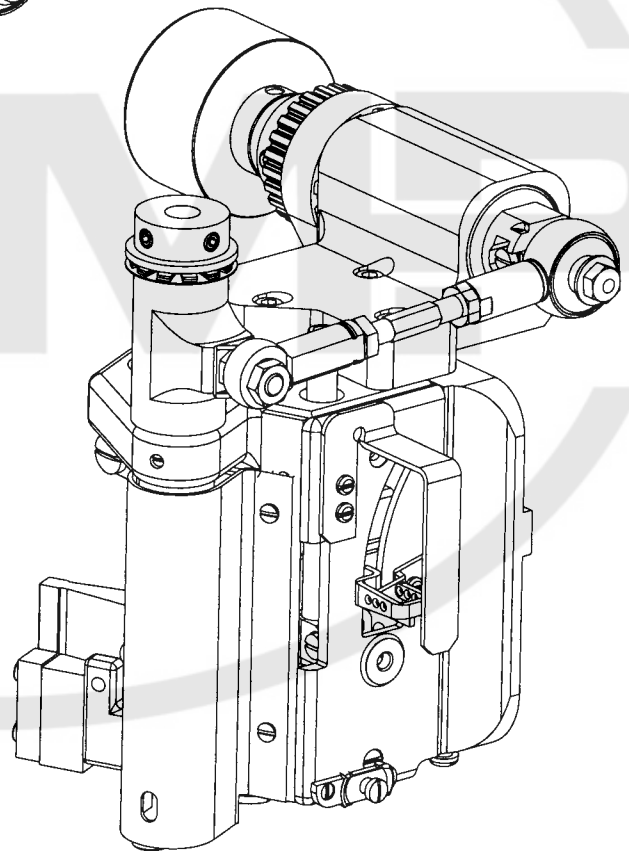
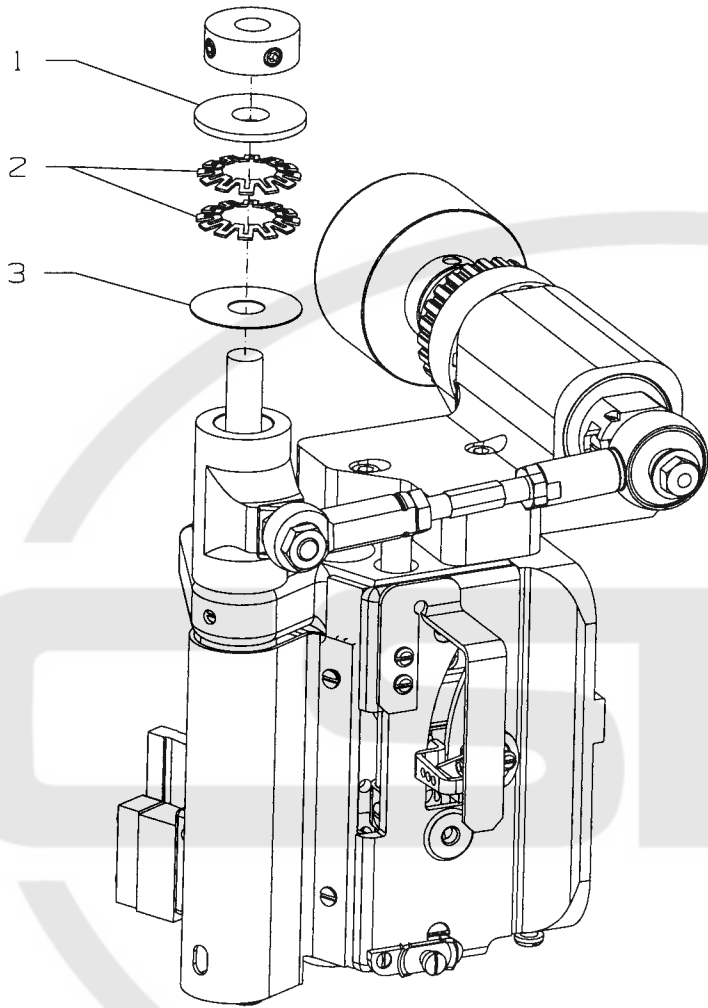

PULLER BRAKE ASSEMBLY

Ref. No.	Part No.	Description	Amt. Req.
1.	50377AE	Disc	1
2.	661-261	Cup Spring	2
3.	35886K	Washer	1



TORQUE:
15-18in. lbs. Max.
1.7-2.0Nm Max.

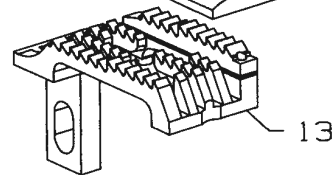
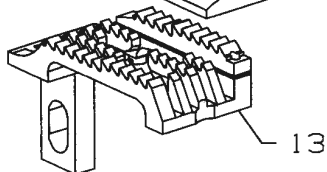
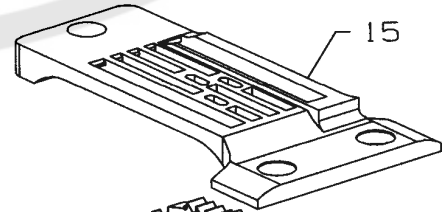
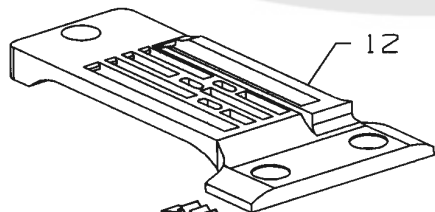
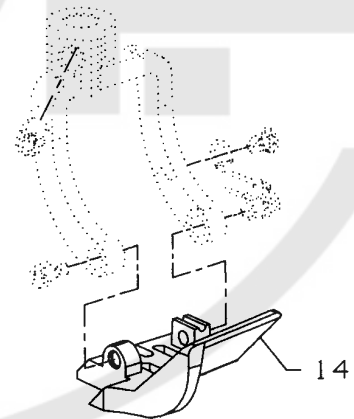
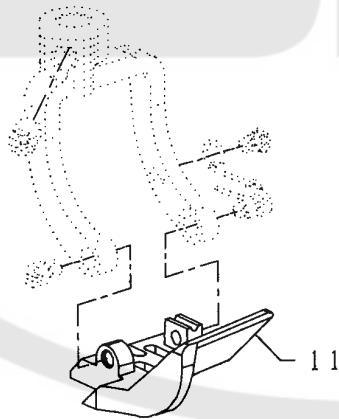
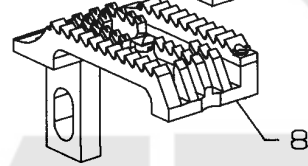
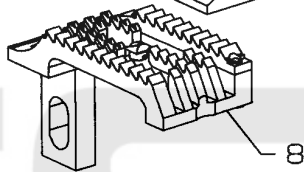
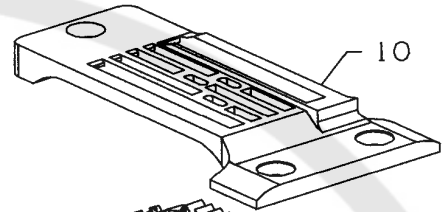
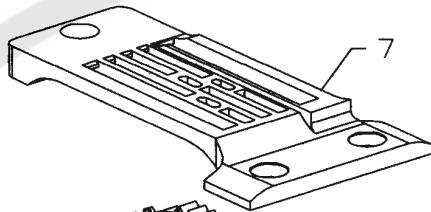
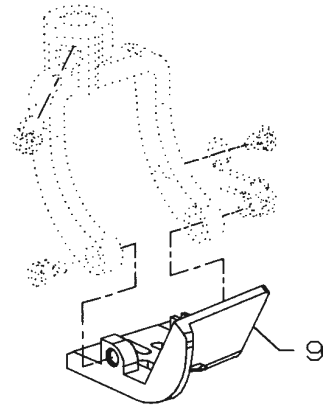
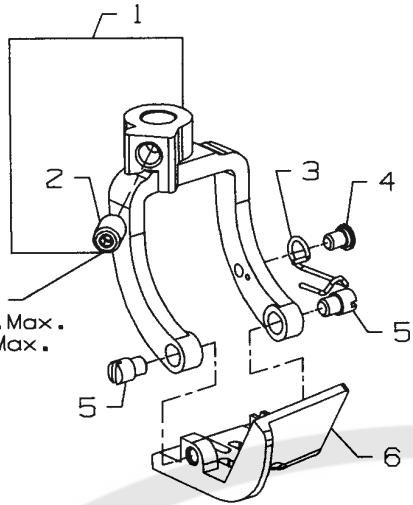

SEWING PARTS FOR PLAIN FEED

Ref. No.	Part No.	Description	Amt. Req.
1.	35830DY	Presser Foot Fork	1
2.	22894BJ	Screw	1
3.	35830K	Spring	1
4.	22599	Screw	1
5.	22845A	Screw	2
6.	35820BQW8	Presser Foot, for Style 35800BQW8	1
7.	35824BQW8	Throat Plate, for Style 35800BQW8	1
8.	35805BQW9	Main Feed Dog, for Styles 35800BQW8, 9	1
9.	35820BQW9	Presser Foot, for Style 35800BQW9	1
10.	35824BQW9	Throat Plate, for Style 35800BQW9	1
11.	35830BXW8	Presser Foot, for Styles 35800BRW8, BRWL8	1
12.	35824DQW8	Throat Plate, for Styles 35800BRW8, BRWL8	1
13.	35805BRW8	Main Feed Dog, for Styles 35800BRW8, 9 BRWL8, 9 BWDR8, 9	1
14.	35830BXW8	Presser Foot, for Styles 35800BWDR8	1
-	35830BXW9	Presser Foot, for Styles 35800BRW9, BRWL9, BRWH9, BWDR9	1
15.	35824DQW8	Throat Plate, for Styles 35800BWDR8	1
-	35824DQW9	Throat Plate, for Styles 35800BRW9, BRWL9, BRWH9, BWDR9	1
16.	35805BRWH9	Main Feed Dog, for Styles 35800BRWH9	1

CSMP



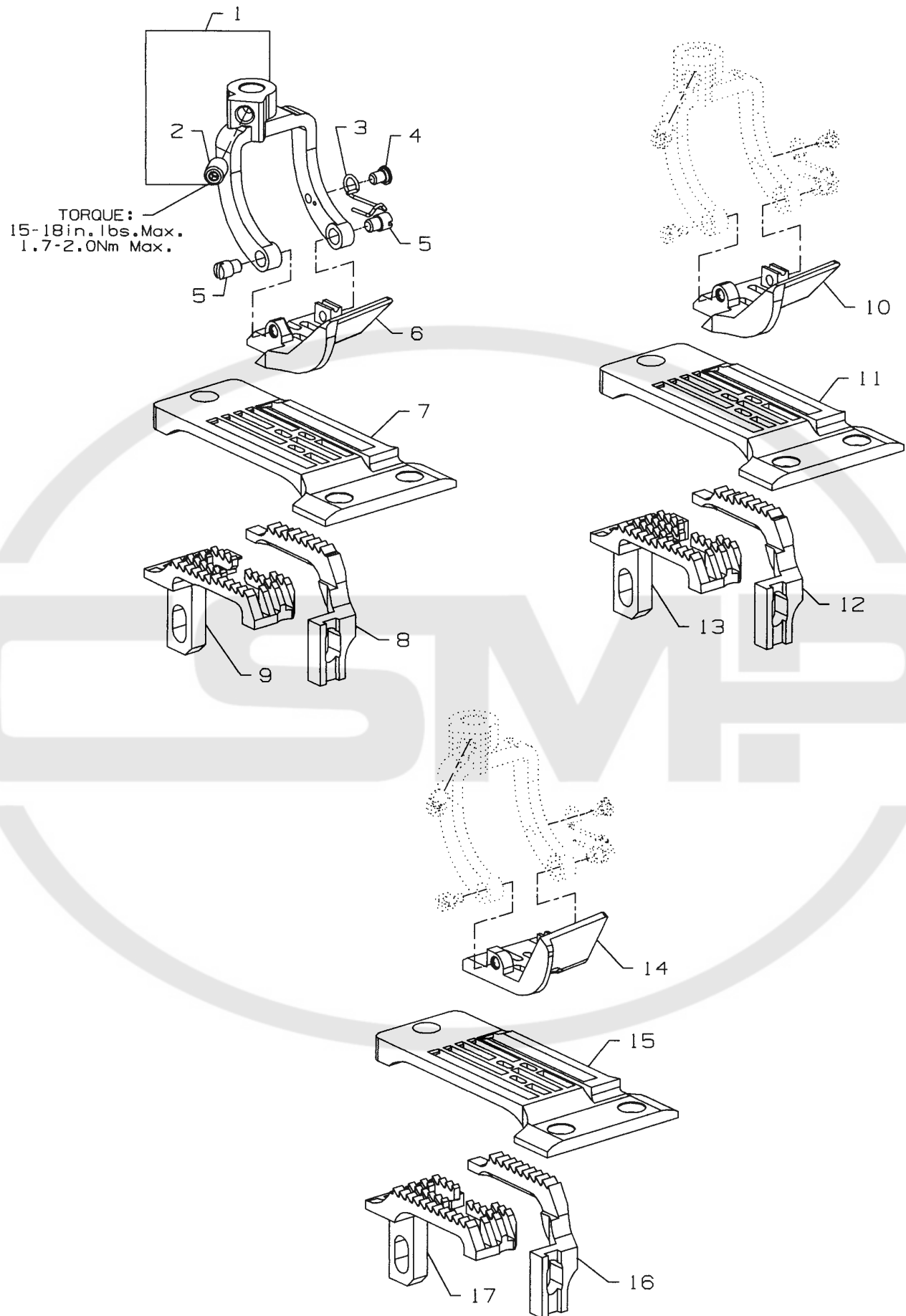

SEWING PARTS FOR DIFFERENTIAL FEED

Ref. No.	Part No.	Description	Amt. Req.
1.	35830DY	Presser Foot Fork	1
2.	22894BJ	Screw	1
3.	35830K	Spring	1
4.	22599	Screw	1
5.	22845A	Screw	2
6.	35830DWW8	Presser Foot, for Styles 35800BWW8, BWWL8	1
-	35830DWW9	Presser Foot, for Styles 35800BWW9, BWWL9	1
7.	35824DX8	Throat Plate, for Styles 35800BWW8, BWWL8, BWDN8	1
-	35824DX9	Throat Plate, for Styles 35800BWW9, BWWL9, BWDN9	1
-	35830DN8	Presser Foot, for Style 35800 BWDN8	1
-	35830DN9	Presser Foot, for Style 35800 BWDN9	1
8.	35826DX	Differential Feed Dog, for Styles 35800 BWW8, 9, BWWL 8, 9	1
-	35826ED	Differential Feed Dog, for Styles 35800 BWDN8, 9	1
9.	35805DX	Main Feed Dog, for Styles 35800 BWW8, 9, BWWL8, 9	1
-	35805EB8	Main Feed Dog, for Styles 35800 BWDN8, 9	1
10.	35830DWW18	Presser Foot, for Styles 35800 BWW18, BWWL18	1
11.	35824DW18	Throat Plate, for Styles 35800 BWW18, BWWL18	1
12.	35826DX	Differential Feed Dog, for Styles 35800BWW18, BWWL18	1
13.	35805DW18	Main Feed Dog, for Styles 35800 BWW18, BWWL18	1
14.	35820BQW9	Presser Foot, for Style 35800 BLW9	1
15.	35824BQW9	Throat Plate, for Style 35800 BLW9	1
16.	35826DLW9	Differential Feed Dog, for Style 35800 BLW9	1
17.	35805DLW	Main Feed Dog, for Style 35800 BLW9	1



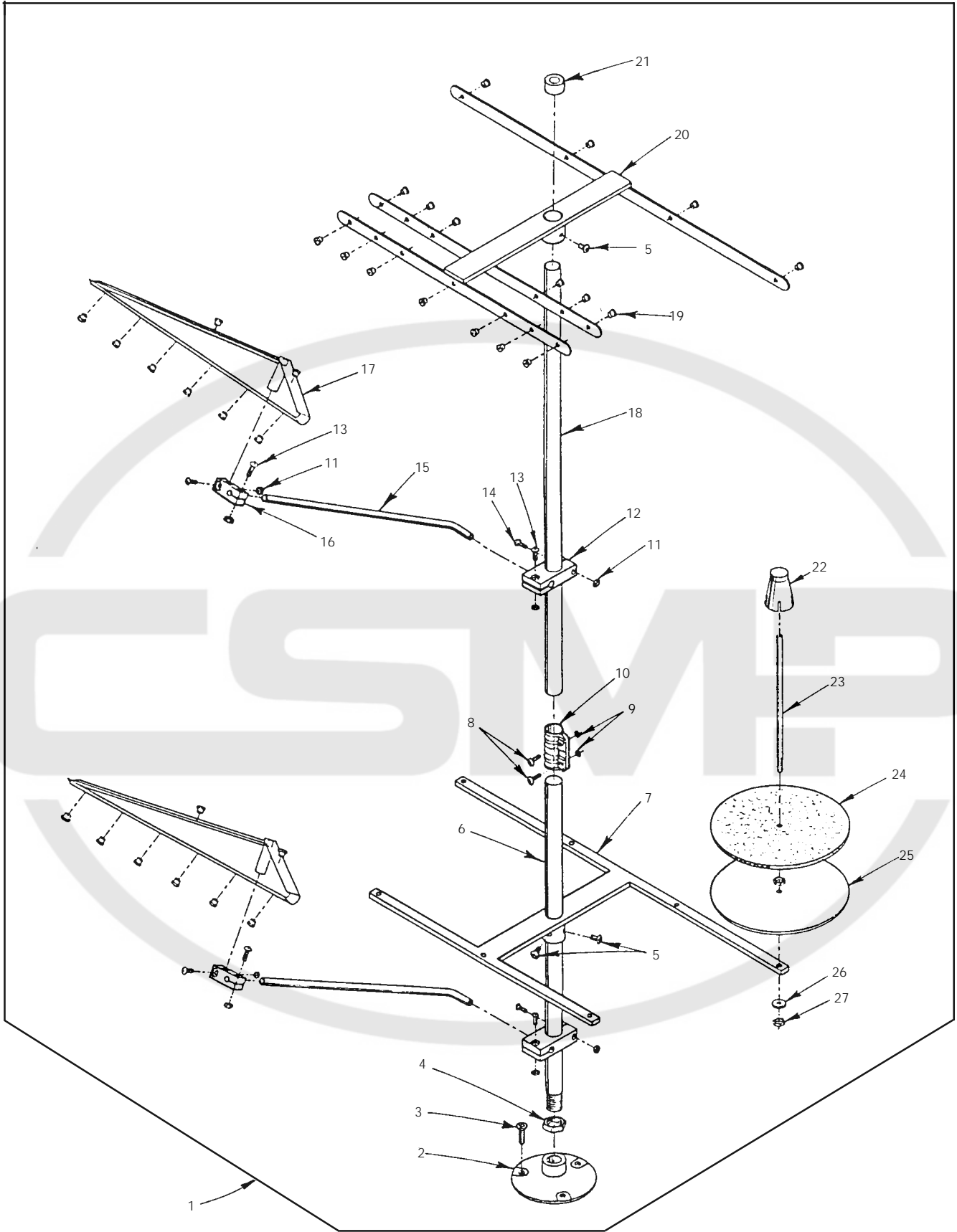

P191-94



THREAD STAND

Ref. No.	Part No.	Description	Amt. Req.
1.	21101S7	Thread Stand, complete	1
2.		Thread Stand Base	1
3.		Screw	3
4.		Nut	1
5.		Screw	4
6.		Thread Stand Rod, short	1
7.		Base Bracket	1
8.		Screw	2
9.		Nut	2
10.		Joint	1
11.		Nut	8
12.		Holder, large	2
13.		Screw	6
14.		Screw, long	2
15.		Thread Guide Rod	2
16.		Holder, thread guide	2
17.		Thread Guide	2
18.		Thread Stand Rod, long	1
19.		Thread Eyelet	34
20.		Thread Guide	1
21.		Cap	1
22.		Spool Retainer	7
23.		Spool Pin	7
24.		Felt Disc	7
25.		Support Disc	7
26.		Spring Washer	7
27.		Nut	14



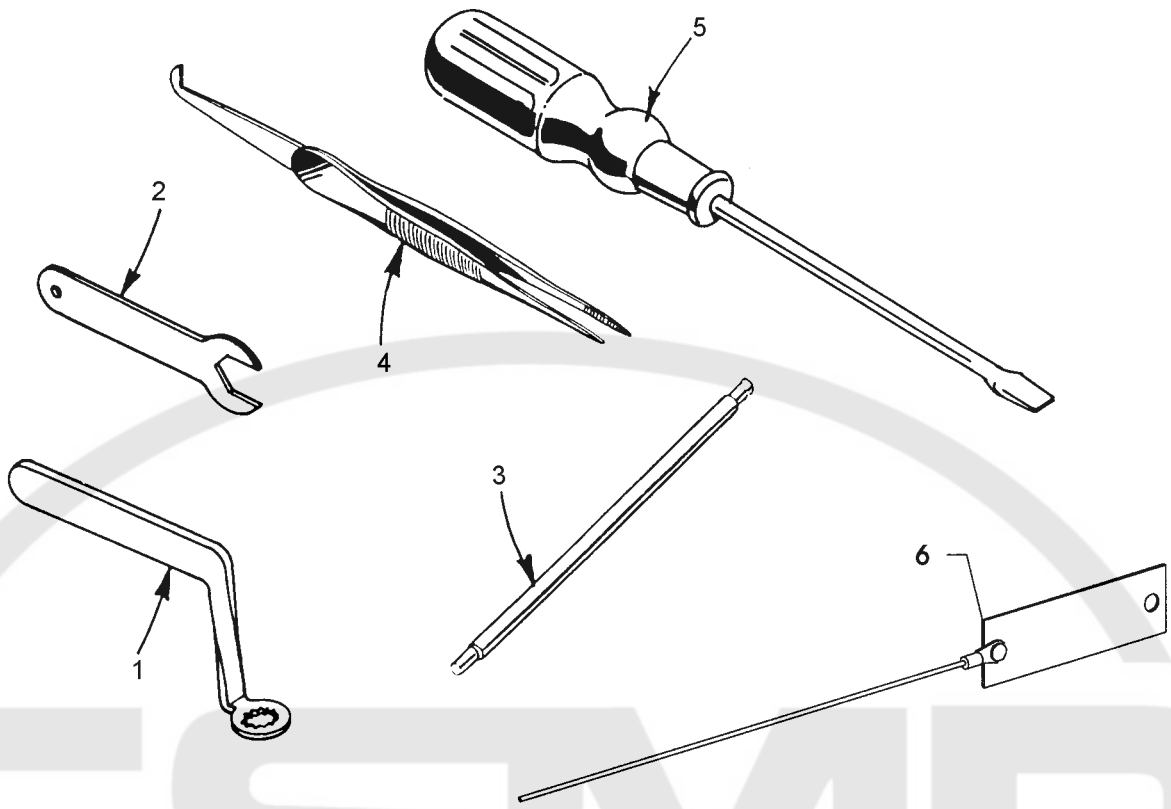

P186-94

ACCESSORIES

Ref. No.	Part No.	Description	Amt. Req.
1.	TT85	Wrench, for looper avoid	1
2.	21388AZ	Wrench, for feed bar	1
3.	21227AR	Needle Head Torque Rod	1
4.	660-240	Thread Tweezers	1
5.	21201	Screwdriver	1
-	28604R	Oil Can (not shown)	1
-	660-1012	Oil Nozzle (not shown)	1
-	660-457	Plastic Cover (not shown)	1
-	WR56	Allen Wrench, size 1/4" (not shown)	1
-	WR58	Allen Wrench, size 3/8" (not shown)	1
-	WR60	Allen Wrench, size 1/2" (not shown)	1
6.	39899A	Threading Wire	1

NUMERICAL INDEX OF PARTS

<u>Part No.</u>	<u>Page No.</u>	<u>Part No.</u>	<u>Page No.</u>	<u>Part No.</u>	<u>Page No.</u>	<u>Part No.</u>	<u>Page No.</u>
109	49	22711	21	23424S	27, 31	35781D	23
12934A	21	22729C	39, 41	23424T	27, 31	35792	49
14649	47	22729C	43, 45	23425T	27, 31	35792T	49
15438C	33	22729D	43	255	49	35796B	25, 31
18	39, 41, 43, 53	22730	21	258	39	35796C	25, 31
20	53	22733A	27	258A	43, 45	35805BQW9	57
21101S7	61	22733B	21	269	39, 41, 43	35805BRW8	57
21201	62	22733G	41, 45	27-435BLK	25, 31	35805BRWH9	57
21227AR	62	22738	47	28604R	62	35805DLW	59
21237ES	47	22743	39	29101G	39	35805DW18	59
21388AZ	62	22747	25, 31	29103T	41	35805DX	59
21756G	35, 37	22747	39, 41	29103U	41	35805EB8	59
22504C	41	22752B	43	29105BH	23	35808AY	43, 45
22513D	31, 33	22758C	47, 49	29105BL	23	35809AY	43, 45
22516A	21	22758E	33	29472AA	35	35809BY	43, 45
22517	49	22759A	21	29472AC	35, 37	35815C	35, 37
22519F	35, 37	22760A	27, 31	29472AD	37	35816	35, 37
22524	25, 29, 33	22764	39	29476SE	51	35817S	33
22526	43, 45	22766	23, 29	29476TE	51	35818CB-8	33
22526B	25	22768	33, 39	29476UD	51	35818CB-9	33
22528	41	22768	41, 53	29476UE	51	35820BQW8	57
22539AL	27, 29	22784F	49	29476VE	53	35820BQW9	57
22539C	27	22791E	25, 31	29476YR	33	35820BQW9	59
22539H	27	22795	53	29478AH	43	35821T	53
22539T	23	22797	35, 37	29478AJ	43	35821W	53
22560A	29, 45	22798	25, 29, 31	29478BD	39	35822AE	33, 49
22561A	25	22804	41	29478CZ	29	35822AH	51
22562A	43, 45	22829	23	29478DV	41	35822W	35, 37
22564	35, 37	22839D	49	29478DZ	43, 45	35824BQW8	57
22564	43, 45	22845A	57, 59	29478EB	41	35824BQW9	57
22564B	21, 27	22845M	41	29478EC	45	35824BQW9	59
22564J	29	22849	27, 31	29478ED	47	35824DQW8	57
22569B	23	22849A	25, 27	29478EL	47	35824DQW9	57
22569D	53	22849A	29, 31	318	33	35824DW18	59
22570	23	22874C	39	33174B	41	35824DX8	59
22570A	23	22894AA	41	34736L	53	35824DX9	59
22571A	27	22894AM	35, 37	34776L	53	35825AC	39, 41
22571B	35, 37	22894BJ	57, 59	35722AF	43, 45	35826CB	47
22572	39	22894C	47, 53	35723C	35, 37	35826DLW9	59
22572B	45	22894E	53	35731A	33	35826DX	59
22580A	39	22894F	23	35736A	39	35826DZ	47
22580D	35, 37	22894J	35, 37	35736B	39	35826ED	59
22585A	35, 37	22894J	49, 53	35751	43	35826X	47
22585A	49	22894K	35, 37	35751B	43	35829AJ	33
22585C	31, 47	22894P	41, 47, 53	35751F	43	35830BXW8	57
22587B	35, 37	22894U	45	35751G	43, 45	35830BXW9	57
22587E	39, 41	22894W	31, 37	35761	35, 37	35830DN8	59
22587H	41	22894W	41, 45	35761D	23	35830DN9	59
22594	33	22894W	47, 53	35763F	35, 37	35830DWW18	59
22596	29, 31	23420AY18-1/8	27, 31	35763G	35, 37	35830DWW8	59
22596B	35, 37	23421Y9-1/8	27, 31	35766A	43	35830DWW9	59
22599	57, 59	23422AY18-1/8	27, 31	35766B	45	35830DY	57, 59
22653B12	53	23424AA	27, 31	35772S	21	35830K	57, 59
22653E-24	23	23424F	27, 31	35772T	21	35832A	49

NUMERICAL INDEX OF PARTS

<u>Part No.</u>	<u>Page No.</u>	<u>Part No.</u>	<u>Page No.</u>	<u>Part No.</u>	<u>Page No.</u>	<u>Part No.</u>	<u>Page No.</u>
35833R	51	35851A	43	35883AX	53	35897BU	35, 37
35833S	51	35851G	43	35883E	25	35897BV	35, 37
35834AB	41	35851P	45	35883G	25, 31	35897BW	35, 37
35834AC	41	35851S	45	35883H	25	35897BY	35, 37
35834G	39	35853AA	21	35883J	25	35897CC	35, 37
35834N	39	35853AD	43	35883M	25	35897CH	37
35834R	39	35853AJ	43, 45	35883N	29	35897CK	33
35834U	39	35853AK	43, 45	35883P	29	36204B	21
35834V3	39	35853V156	43, 45	35883R	31	36229A-1	29
35834W	41	35853W	21	35883T	29	36229A1	25
35834X	41	35853Y	21	35883U	31	36234C	41
35835B	39, 41	35853Z	21	35884E	25	36234F	41
35835F	47	35854A	33	35884F	25	36234G	41
35836	39	35854B	33	35884H	25	36234M	41
35836A	41	35856Y	29	35884K	31	36236A	41, 45
35836B	41	35860D	23	35884L	27	36236B	45
35836C	45	35860E	23	35884R	25, 29	36236C	45
35837A	43	35862A	35, 37	35884S	33	36236G	41
35837N	43	35864F	35, 37	35884T	33	36236H	41, 45
35837P	33	35866	43, 45	35886B	27	36236J	41
35837W	53	35866A	23	35886C	27	36236K	41
35837X	53	35866B	23	35886H	51	36236L	41
35838A	33	35866C	23	35886J	51	36237	41
35838B	33	35870	33	35886K	55	36237A	41
35841B	39	35871A	23	35886M	51	36237E	29
35842	43	35871B	23	35887AE	21	36237H	29
35842H	43	35873AJ	47	35887AF	23	36237J	29
35843B	39	35873AK	47	35887AG	21	36237K	29
35843C	49	35874V	53	35887AJ	53	36237L	29
35843D	33, 49	35875AA	47	35887AK	53	36238	29
35844	39	35875X	47	35887M	21	36238E	29
35844C	39	35875Y	47	35887R	21	36244	41
35844F	53	35875Z	47	35887X	21	36244A	41
35844N	33	35876AH	53	35887Z	23	36244D	23
35844T	33	35876U	23	35888N	21	36249A	29
35844W	53	35877AA	47	35888T	21	36249B	45
35844X	53	35877AB	53	35889G	33	36256B	27, 31
35844Y	39	35877AD	33	35889H	23	36261A	35, 37
35844Z	39	35877AF	53	35890E	23	36278C	45
35845D	39	35877AG	53	35890Q	23	36280N	49
35845E	53	35877AH	53	35890R	23	36280S	49
35846	39	35877AM	33, 47	35892A	47	36280T	49
35846B	39	35877AN	51	35893G	21	36280U	47
35847E	39	35880L	49	35893H	21	36280V	47
35847X	35, 37	35880N	49	35894K	35, 37	36280W	49
35848B	43, 45	35880P	49	35894V	35, 37	36282	31
35848D	43, 45	35882F	53	35895V	43, 45	36283C	31
35848E	43, 45	35882J	33	35895W	35, 37	36284	25, 29
35849B	43	35882K	33	35895Y	35, 37	36284C	29
35849C	45	35882S	53	35895Z	35, 37	36284E	31
35850B	25	35882T	33	35896B	31	36284F	31
35850C	25	35883A	25	35896D	33	36286	29
35850G	27, 31	35883AA	29	35897AX	27	36286B	29
35851	43	35883AL	23	35897BM	35	36290B	23



NUMERICAL INDEX OF PARTS

<u>Part No.</u>	<u>Page No.</u>	<u>Part No.</u>	<u>Page No.</u>	<u>Part No.</u>	<u>Page No.</u>
36292K	49	660-303	47	SS7111120TP	51
36292M	49	660-310	43, 45	SS7111410TP	33
36292N	49	660-457	62	SS7111410TP	49
36292Q	49	660-548	39	SS7121410TP	33
36293B	21	660-675	53	SS7151310TP	51
36293F	21	660-764	23	SS8080310TP	39
36293G	31	660-935	23	SS8120410SP	33
36298G	49	660-974	53	TT85	62
36298H	49	661-150	31	W56392F	49
376	39	661-261	55	WC50092S	49
39141	43	661-348	23	WO3	33, 35, 37, 41
39592AK	49	664F-16	33	WR56	62
39899A	62	666-149	35, 37	WR58	62
41071G	21	666-338	35, 37	WR60	62
41255B	41	666-340A	33	WZ0641510KP	33
41355U	39	666-47	39		
43246	39	667D-16	25, 29		
43296	33	671A146-1	51		
50-458BLK	43, 45	671A254	51		
50311C	23	671A256A	51		
50377AE	55	671A35	51		
50377L	47	671F81C	51		
51054A	35, 37	73A	21, 27, 31		
51292F14	49	73C	47		
51292F4	49	73X	53		
51758	25	77	35, 37, 41		
531	25, 27, 29, 31	80040-1	53		
53634C	53	8372A	23, 27		
538	29, 39	86	47		
54274C	47	87A	29		
54279	53	87U	27, 31, 39, 41		
56341G	43, 45	88	27, 39, 43, 47		
56354D	35, 37	89	43		
57WB	33	90	21, 25, 35, 37		
57WD	33	93	21		
60078Z	29	93A	21		
6042A	21, 33, 43	94	49		
605	33	9937	33		
62238A	41, 45	99622A	53		
660-1012	62	999-196	31		
660-1115	27, 29	B3530555000	21		
660-1117	27, 31	C067E	23		
660-1132	23	C50042AG	53		
660-206	21	CL21	23		
660-207	41, 45	J87J	25, 29		
660-212	21	LA527	23		
660-219	53	SD0640241SP	33		
660-219AT	51	SD0640241SP	49		
660-219S	49	SS4091015SP	33		
660-220	29, 41	SS6120930TP	53		
660-220	43	SS6121010SP	33		
660-221	39	SS7110510SP	23		
660-240	62	SS7110910TP	37		
660-254C	49	SS7111120TP	35		





JUKI
Union Special