

MANUAL NO.

INS9202

2ND Edition

Adjusting Instructions

STYLES

36200AK
36200PA
36200PH
36200PJ
36200PM
36200PX
36200TA
36200TH
36200TJ
36200TM
36200TX

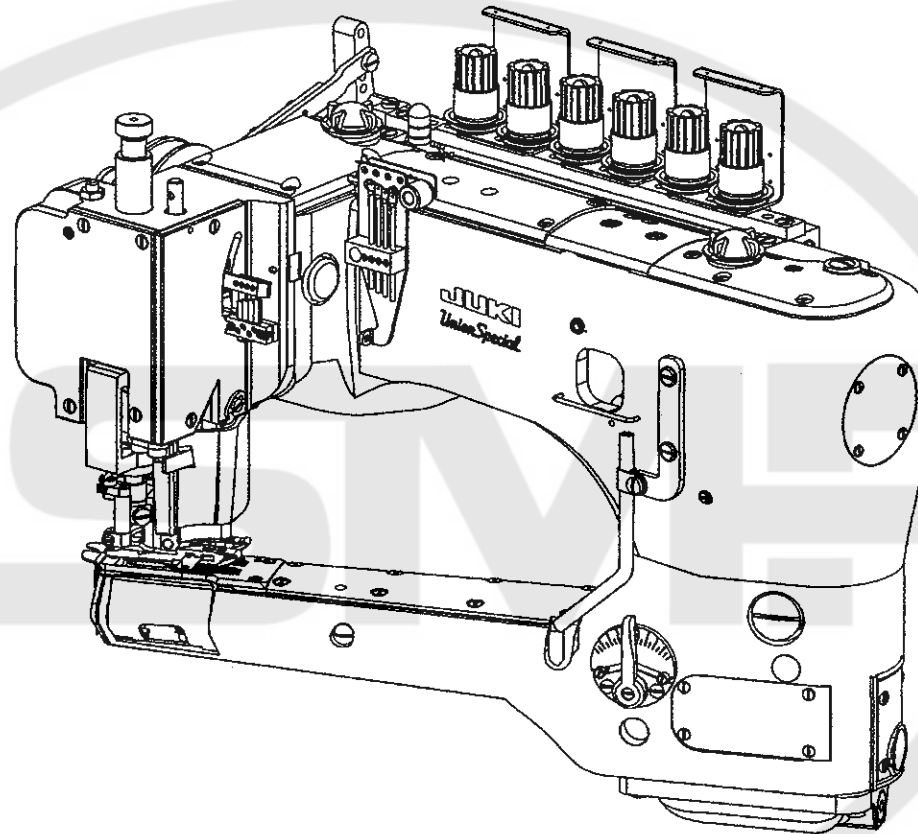

36200 CLASS



Finest Quality

Union Special
INDUSTRIAL SEWING EQUIPMENT

Manual No. Ins9202 Adjusting instructions for 36200 Series Styles

36200AK
36200PA
36200PH
36200PJ
36200PM
36200PX

36200TA
36200TH
36200TJ
36200TM
36200TX

Second Edition Copyright 2000
By
Union Special Corporation Rights Reserved In All Countries
Printed in U.S.A. Dec 2000



PREFACE

This technical manual has been prepared to guide you while adjusting the 36200 Series machines. It can be used in conjunction with Union Special Parts Manual PRT9201.

This manual explains in detail the proper setting for each of the components to forming the stitch and completing the functions of the machine. Illustrations are used to show the adjustments and reference letters are used to point out specific items discussed.

Careful attention to the instructions for operating and adjusting these machines will enable you to maintain the superior performance and reliability designed and built into every Union Special machine.

Adjustments are presented in sequence so that a logical progression is accomplished. Some adjustments performed out of sequence may have an adverse effect on the function of other related parts.

This manual has been comprised on the basis of available information. Changes in design and /or improvements may incorporate a slight modification or configuration in illustrations.

Este manual se ha hecho con la información disponible.

Cambios en diseño y la mejoras puede incorporar una pequeña modificación, de la configuración en las ilustraciones o número de partes.

Dieses Handbuch wurde auf Basis vorhandener Information erstellt. Konstruktionsänderungen und / oder Weiterentwicklungen können eine geringfügige Veränderung der Abbildungen oder der Teilenummern bedingen.

SAFETY RULES:

1. Before putting the machines described in this manual into service, carefully read the instructions. The starting of each machine is only permitted after taking notice of the instructions and by qualified operators.

IMPORTANT! Before putting the machine into service, also read the safety rules and instructions from the motor supplier.

2. Observe the national safety rules valid for your country.
3. The sewing machines described in this instruction manual are prohibited from being put into service until it has been ascertained that the sewing units which these sewing machines will be built into, have conformed with the EC Council Directives (89/392/EEC, Annex II B).

Each machine is only allowed to be used as foreseen. The foreseen use of the particular machine is described in paragraph "STYLES OF MACHINES" of this instruction manual. Another use, going beyond the description, is not as foreseen.

4. All safety devices must be in position when the machine is ready for work or in operation. Operation of the machine without the appertaining safety devices is prohibited.
5. Wear safety glasses.
6. In case of machine conversions and changes all valid safety rules must be considered. Conversions and changes are made at your own risk.
7. The warning hints in the instructions are marked with one of these two symbols:



8. When doing the following the machine has to be disconnected from the power supply by turning off the main switch or by pulling out the main plug:
 - 8.1 When threading needle(s), looper, spreader etc.
 - 8.2 When replacing any parts such as needle(s), presser foot, throat plate, looper, spreader, feed dog, needle guard, folder, fabric guide etc.
 - 8.3 When leaving the workplace and when the workplace is unattended.
 - 8.4 When doing maintenance work.
 - 8.5 When using clutch motors without actuation lock, wait until the motor is stopped totally.
9. Maintenance, repair and conversion work (see item 8) must be done only by trained technicians or special skilled personnel under consideration of the instructions.
10. Any work on the electrical equipment must be done by an electrician or under direction and supervision of special skilled personnel.
11. Work on parts and equipment under electrical power is not permitted. Permissible exceptions are described in the applicable sections of standard sheet DIN VDE 0105.
12. Before doing maintenance and repair work on the pneumatic equipment, the machine has to be disconnected from the compressed air supply. In case of existing residual air pressure, after disconnecting from compressed air supply (i.e. pneumatic equipment with air tank), the pressure has to be removed by bleeding.



CONTENTS

| | |
|--|----|
| PREFACE..... | 3 |
| SAFETY RULES: | 4 |
| IDENTIFICATION OF MACHINES:..... | 6 |
| TORQUE REQUIREMENTS: | 6 |
| DESCRIPTION OF MACHINES: | 6 |
| MACHINE STYLES: | 6 |
| MACHINE STYLES: | 7 |
| THREADING | 8 |
| OILING | 9 |
| ADJUSTING INSTRUCTIONS | 10 |
| SETTING THE NEEDLE BAR HEIGHT | 10 |
| SETTING THE NEEDLE BAR HEIGHT (CONT.) | 11 |
| CENTERING THE CYLINDER | 11 |
| INSTRUCTIONS FOR USING SYNCHRONIZING GAUGE 21277CG | 12 |
| SETTING THE LOOPER TRAVEL | 12 |
| TIMING THE NEEDLES TO THE LOOPER | 12 |
| TIMING THE NEEDLES TO THE LOOPER (CONT.)..... | 13 |
| LOOPER ADJUSTMENTS | 14 |
| SETTING THE FRONT NEEDLE GUARD | 15 |
| SETTING THE FEED DOGS | 15 |
| SETTING THE REAR NEEDLE GUARD | 16 |
| SETTING THE STITCH LENGTH | 16 |
| DIFFERENTIAL FEED CONTROL..... | 16 |
| SETTING THE PRESSER FOOT | 16 |
| SETTING THE PRESSER FOOT (CONT.) | 17 |
| SETTING THE PRESSER FOOT (CONT.) | 18 |
| SETTING THE KNIFE DRIVE LEVER | 18 |
| SETTING THE KNIFE DRIVE LEVER (CONT.) | 19 |
| SETTING THE TRIMMING KNIVES (STYLES 36200 AK, PA, PJ, PX, TA, TJ, TX)..... | 19 |
| SETTING THE TRIMMING KNIVES (STYLES 36200 PH, PM, TH, TM) | 19 |
| SETTING THE TRIMMING KNIVES (ALL STYLES) | 19 |
| SETTING THE TRIMMING KNIVES (ALL STYLES) (CONT.) | 20 |
| NEEDLE THREAD ADJUSTMENTS | 20 |
| NEEDLE THREAD ADJUSTMENT (CONT.)..... | 21 |
| LOOPER THREAD ADJUSTMENT | 21 |
| COVER THREAD ADJUSTMENT | 21 |
| TENSION RELEASE | 21 |
| HUNG FOOT ADJUSTMENT | 22 |
| SETTING THE LAP FORMER (STYLES 36200 PH, PM, TH, TM ONLY) | 22 |
| NOTES | 23 |



IDENTIFICATION OF MACHINES:

Each UNION SPECIAL machine is identified by a style number, which on this machine class is stamped into the style plate affixed to the right side of the top front cover. The serial number is stamped into the casting to the right of the style plate.

TORQUE REQUIREMENTS:

Torque (measured in inch-pounds) is a rotating force (in pounds applied through a distance by a lever (in inches or feet). This is accomplished by a wrench, screwdriver, etc. Many of these devices are available, which when set at the proper amount of torque will tighten the part to the correct amount and no tighter.

All straps and eccentrics should be tightened to 19-21 inch-pounds (22-24cm/kg) unless otherwise noted. All other nuts, bolts, screws, etc. should be tightened by hand as tightly as possible, unless otherwise noted.

Screws requiring a specific torque will be indicated on the illustrations in 36200 Parts Manual PRT9201.

DESCRIPTION OF MACHINES:

Feed-off-the-arm, high speed, medium throw, five or six thread machine. There are four needles and one retainer abreast, one looper and a manually adjusted differential feed control. There is an enclosed automatic lubricating system, filter type oil return pump, visual sight oil action and supply gauges. The maximum work space in front of the needles is 8 inches (203.2mm). Recommended speed - 4200 R. P. M. for all styles. Styles starting with a "T" are prepared for table installation and styles starting with a "P" are prepared for a pedestal installation.

MACHINE STYLES:

- 36200AK** FLATSEAMER six thread dial adjusted differential feed. for simultaneously trimming and flatseaming knit undergarments, infants clothing and similar light to medium weight materials where closing elastic is required. Seam specifications 607-FSa-1. Components produce a .205" (5.2mm) wide seam.
- 36200TA** FLATSEAMER six thread dial adjusted differential feed. for simultaneously trimming and flatseaming knit undergarments, infants clothing and similar light to medium weight materials where closing elastic is required. Seam specifications 607-FSa-1. Components produce a .205" (5.2mm) wide seam.
- 36200TH** LAP FLATSEAMER six thread dial adjusted differential feed. for simultaneously trimming and closing the crotch seam on men's knit briefs when the added strength of a reinforced seam is required. Also used where crossing elastic and heavy seams, such as leg bindings is necessary. The right section of the sewing parts are raised .050" (1.27mm) to assure a better lap seam. Seam specifications 607-LSa-1. Components produce a .205" (5.2mm) wide seam.
- 36200TJ** FLATSEAMER same as Style 36200TA except fitted with components that produce a .236" (6mm) wide seam.
- 36200TM** FLATSEAMER same as Style 36200TH except fitted with components that produce a .236" (6mm) wide seam.
- 36200TX** TAPE SEAMER five thread dial adjusted differential feed. Simultaneously trims, joins and tapes the front of knit briefs in one operation. Fitted with a taping foot that has the tape slot in front of the needle hole and folder that takes a 3/4" (19.0mm) knitted strip, cut with the wale, to produce a 7/16" (11.1mm) wide finished tape. Seam specifications 607-FSp-4 modified. Seam width is .205" (5.2mm).



MACHINE STYLES:

| | |
|---------|--|
| 36200PA | Same as Style 36200TA except prepared for pedestal installation. |
| 36200PH | Same as Style 36200TH except prepared for pedestal installation. |
| 36200PJ | Same as Style 36200TJ except prepared for pedestal installation. |
| 36200PM | Same as Style 36200TM except prepared for pedestal installation. |
| 36200PX | Same as Style 36200TX except prepared for pedestal installation. |

NEEDLES:

Each needle has both a type and size number. The type number denotes the kind of shank, point, length, groove, finish and other details. The size number, stamped on the needle shank, denotes the largest diameter of the blade measured between the shank and the eye. Collectively, the type and size number represent the complete symbol which is given on the label of all needles packed and sold by Union Special.

| <u>TYPE</u> | <u>DESCRIPTION</u> |
|-------------|---|
| 118 GAS | Extra short, double groove, struck groove, .060" diameter shank, chromium plated needle. Sizes available 065/025, 070/027, 075/029, 080/032, 090/036. |
| 118 GBS | Extra short, single groove, struck groove, spotted, .060" diameter shank, chromium plated needle. Sizes available 075/029, 080/032. |
| 118 GHS | Same as type 118GBS, except with ball point. Sizes available 070/027, 075/029, 080/032. |
| 118 GJS | Same as type 118GHS, except with tapered blade and ball point. Sizes available 065/025, 070/ 027, 075/029. |
| 118GKS | Round shank, round point, extra short, double groove, struck groove, spotted, chromium plated needle. Sizes available 070/027, 075/029, 080/032. |
| 36211 | Retainer needle, no scarf. Sizes available 065/025, 070/027, 075/029. |

APPLICATION:

| | | |
|--------|---------|--|
| 118GKS | 075/029 | Recommended for Styles: 36200AK, PA, PH, PJ, PM, TA, TH, TJ, TM |
| 118GKS | 080/032 | Recommended for Styles: 36200PX, TX |

When changing the needle, make sure it is fully inserted in the needle head before the clamp screw is tightened.

To have needles promptly and accurately filled, an empty package, a needle sample, or the Type and Size number should be forwarded. Use the description on the label. A complete order should read as follows: "100 needles, Type 118GKS, Size 075/029".



THREADING

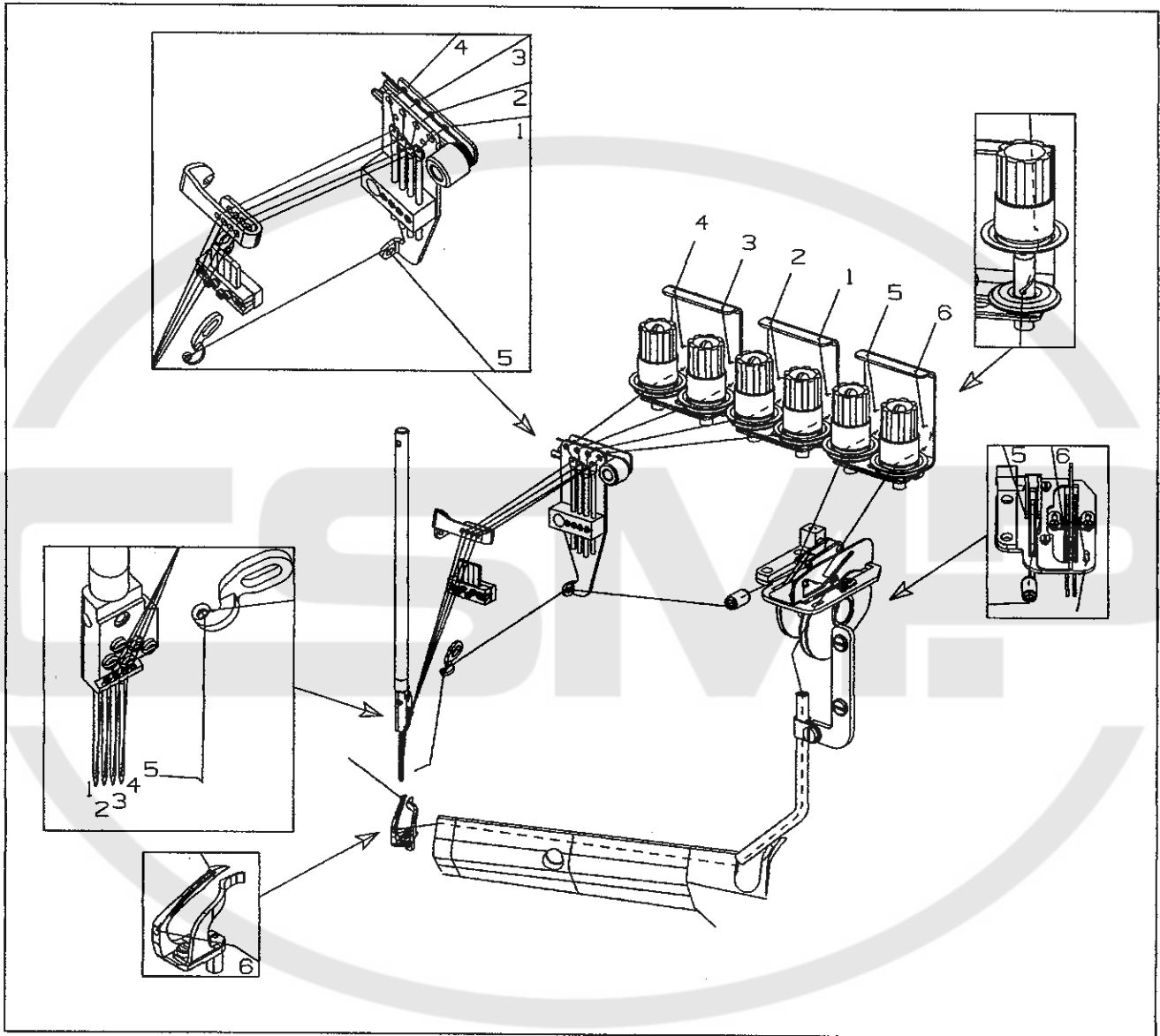

OILING

Referring to Fig. 1, fill the machine at (A) and (B). Oil capacity of class 36200 is 2.5 ounces in the bottom reservoir and 2.5 ounces in the top reservoir. Use a straight mineral oil, Saybolt viscosity of 90 to 125 seconds at 100° Fahrenheit. The oil level is checked at gauges (C) and (D). Maintain oil level between the red lines of these gauges.

This machine is automatically lubricated by a continuously driven rotary pump. Oil flow can be observed through windows (A) and (B). When installing a new machine or starting a machine that has been idle for some time, priming may be necessary. Remove plug screws (E), fill holes with recommended oil and replace screws **BEFORE** operating. If oil does not flow while machine is running, pump is inoperative.

Remove screw 22733B (F, Fig. 1 inset) to drain oil from the top reservoir. To drain oil from bottom reservoir remove magnetic screw 22571E (G).

Occasionally, it is necessary to oil the linkage of the presser foot, the knife holder shank (36273A), guide collar (36273K) and the various links and bearings of the presser foot lifting mechanism and thread tension release.

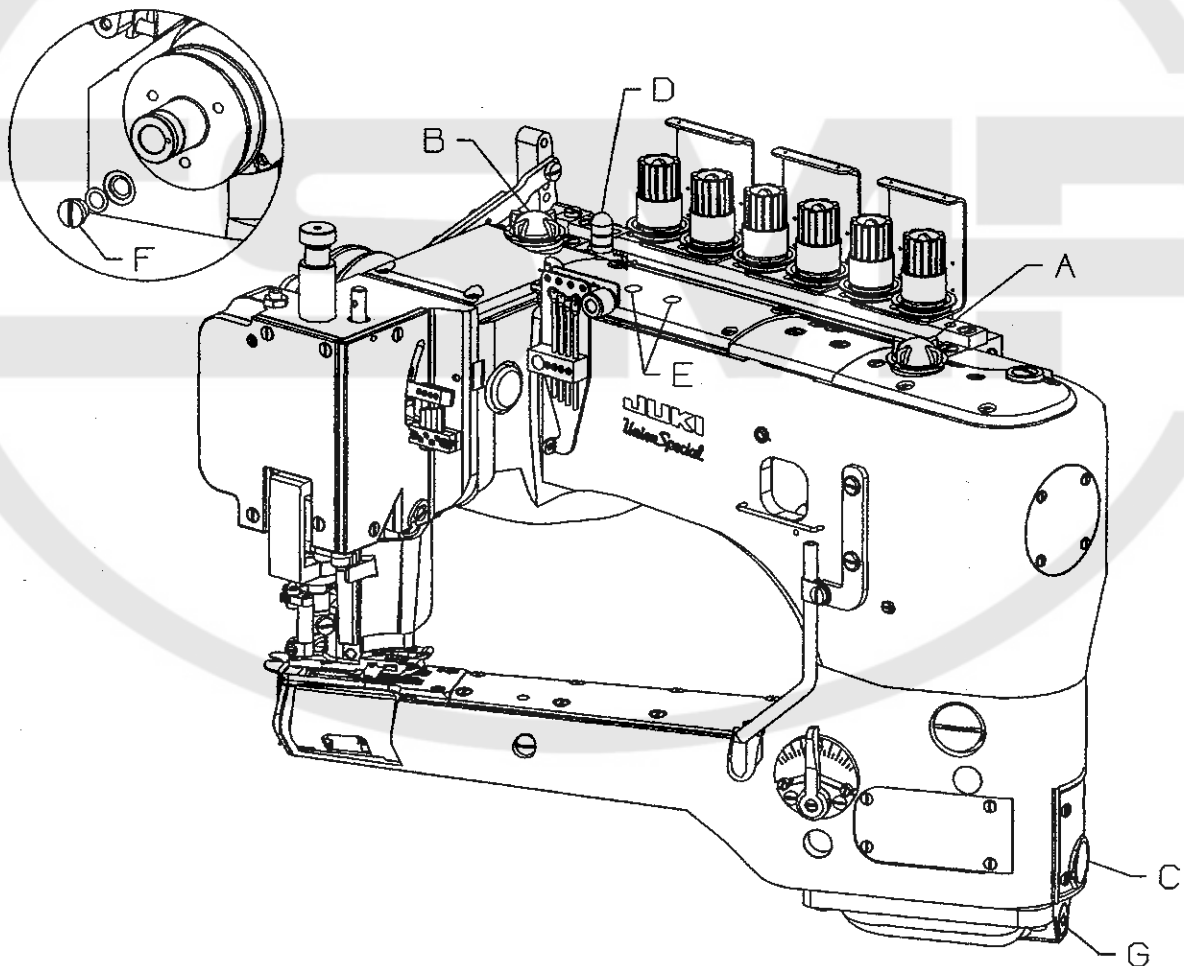

FIG. 1

ADJUSTING INSTRUCTIONS

Instructions stating direction or location, such as right, left, front or rear of the machine are given relative to the operator's position at the machine unless otherwise noted. The handwheel rotates clockwise in operating direction.

SETTING THE NEEDLE BAR HEIGHT

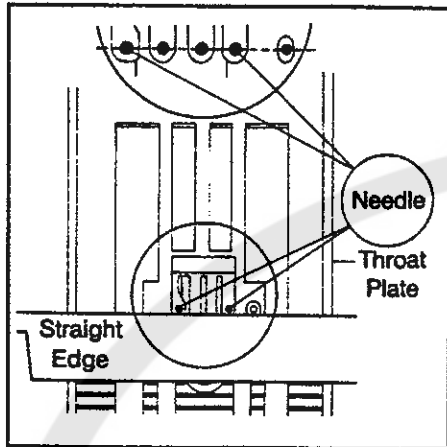

FIG. 2

Insert the first (left) and fourth needles into the needle head. The needles for this Class of machine are made with two flats on the front of the shank. This will enable you to correctly position the needles in the needle head. Make certain the needle shank is fully inserted and that the screw is seated firmly on the flat.

To position the needle head square with the throat plate, use the upper knife or a straight edge to align the needles with the cross grooves in the throat plate. (See Fig. 2)

Refer to table 1 for the dimension from the fourth (lowest) needle to the surface of the throat plate and for the number of the needle bar height gauge.

| STYLE | DIMENSION from 4th (LOWEST) NEEDLE to THROAT PLATE SURFACE | NEEDLE BAR HEIGHT GAUGE NUMBER | NEEDLE HEIGHT GAUGE STEP MARKED |
|----------------------------|--|--------------------------------|---------------------------------|
| AK, PA, PH, PX, TA, TH, TX | 17/32" (13.5mm) | 21227 BU | .531 |
| PJ, PM, TJ, TM | 1/2" (12.7mm) | 21227 DS | .500 |

TABLE 1

Position the needle bar at its highest point of travel. Loosen needle bar clamp screw (A, FIG.3) & use the specified needle bar height gauge (B) to achieve the desired height dimension from the fourth (lowest)

needle (C) to the throat plate surface (D). Tighten clamp screw (A) and recheck setting. Care must be taken not to disturb the needle head alignment while making the adjustment. Add the two middle needles and the retainer.

NOTE: Styles 36200 PH, PM, TH, and TM have a .050" (1.3mm) step on the right side of the throat plate. When setting the needle height measure from the left side or lowest part of the stepped plate.

CAUTION: If the needle head has been replaced it must be torqued to 17 in. lbs. (20cm/kg). Or until torque bar (21227AR), inserted into cross hole in the needle bar, bends. It will not seat against the bottom of the needle bar. After tightening, check for expansion of the needle bar by positioning it up into the lower bushing hole. If the bar has expanded it will bind in the bushing. The bar must be replaced or lapped to reduce the bell shape. Align and set needle bar height as described above.



SETTING THE NEEDLE BAR HEIGHT

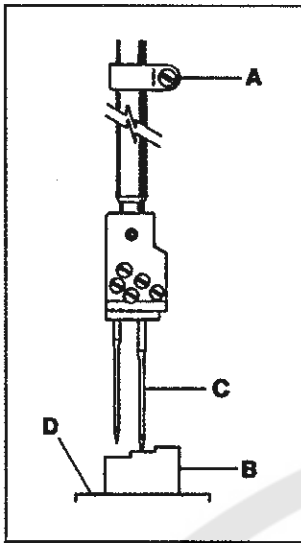

FIG. 3

Correct spacing of the needles in the throat plate stitch tongue is imperative to proper sewing conditions. Improper relationship of the needles to the stitch tongue often results in malformed stitches. When replacing the stitch tongue make sure needles are aligned properly (see Fig. 4).

If the stitch tongue and throat plate are properly seated and the needle position is not correct, the cylinder has probably been forced out of position. If realignment is necessary, refer to the section "Centering the Cylinder".

When the needles are correctly positioned in the throat plate the space to the left of the needles in the stitch tongue slot is .006" (0.15mm) more than the space to the right (see Fig. 4). Actually, the needle bar is centered to the throat plate and cylinder, however, to provide clearance on the left side of the needle for the needle loops passing around the looper during the down stroke of the needles, the slots in the stitch tongue are made off-center to the left. Accurate positioning of the needles may be obtained by repositioning the cylinder.

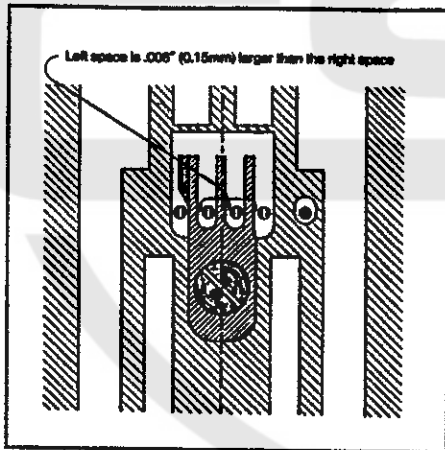

FIG. 4

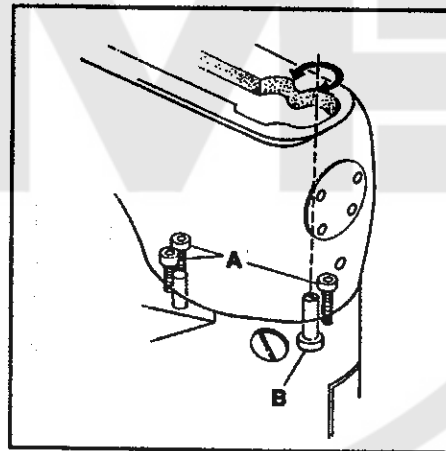

FIG. 5

CENTERING THE CYLINDER

Remove the top front cover and gasket from the main frame. Loosen cylinder holding screws (A, Fig. 5). Turn eccentric screw (B) clockwise to move the cylinder so the needles are closer to the right side of the stitch tongue. Turn the stud counterclockwise to locate the needles closer to the left. Tighten screws (A) and recheck settings. Various components may have to be removed from the machine so cylinder holding screws (A) can be accessed.

NOTE: The cylinder may not move freely when the eccentric is turned because the joint sealant compound has set. Light tapping with a wooden block at the joint or midpoint of the arm may be necessary.

SETTING THE LOOPER TRAVEL

Attach looper travel gauge plate (A, Fig. 6) to the rear of the cylinder arm. Set the bottom of the gauge so it is approximately horizontal and lock lightly in place with screw (B) directly underneath. Attach looper travel gauge pointer (C) to the looper using the left needle guard screw hole. Turn the handwheel in operating direction until the looper is positioned to the far right. Set pointer (C) at zero degrees by rotating gauge plate (A) and lock in place. Continue turning the handwheel until the pointer stops. If the looper travel is correct the pointer should indicate $55^{\circ}40'$ or within one graduation mark on either side.

To adjust the looper travel remove the top front cover and the end cover. Loosen left-handed locknut (A, Fig. 7) and turn screw (B) clockwise to decrease the looper travel or counterclockwise to increase the looper travel. Tighten locknut (A) and recheck setting.

NOTE: After setting the looper travel the machine must be checked for synchronization.

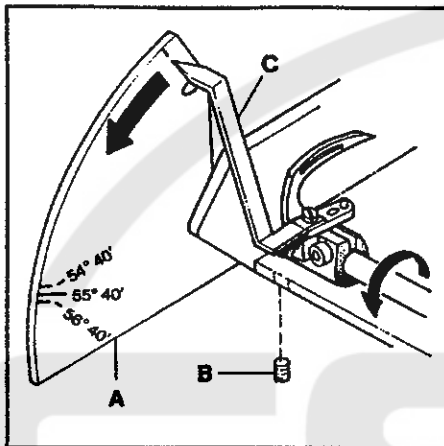

FIG. 6

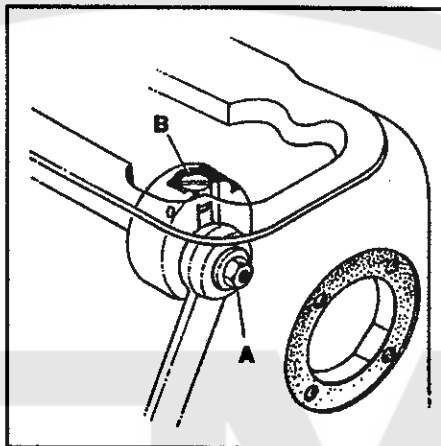

FIG. 7

TIMING THE NEEDLES TO THE LOOPER

To visually check the timing of the needles to the looper, turn the handwheel in operating direction until the needle bar has reached its lowest position and has risen $5/32''$ (4.0mm). At this time the looper point should appear at the same relative position to the needles whether rotation of handwheel is clockwise or counterclockwise.

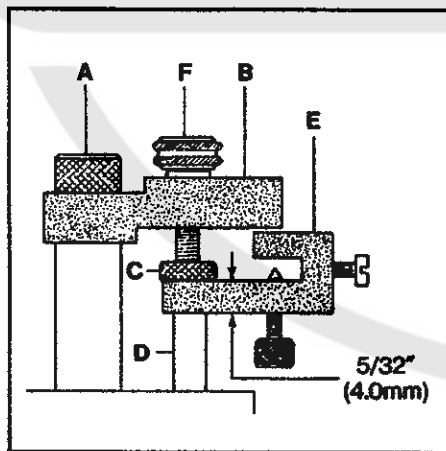

FIG. 8

INSTRUCTIONS FOR USING SYNCHRONIZING GAUGE 21277CG

Turn the handwheel until the needle bar is at its lowest point. Loosen presser bar regulating screw (A, Fig. 8) and insert needle bar setting block (B) under the head of the screw (A) with stop screw (C) above needle bar (D). Tighten screw (A).

The long portion of the looper clamp and height gauge (E, Fig. 8) laid on its side is the $5/32''$ (4.0mm) gauge used to set the distance between stop screw (C) and the top of the needle bar (D) at its lowest position. Tighten nut (F) to clamp stop screw (C) into place.



TIMING THE NEEDLES TO THE LOOPER (CONT.)

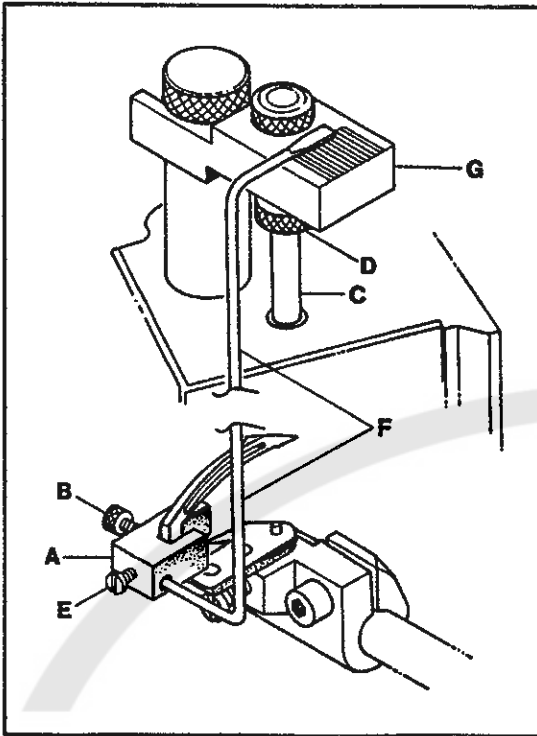

FIG. 9

Attach the looper clamp and height gauge (A, Fig. 9) to the heel of the looper by tightening screw (B). Turn the handwheel slowly in a clockwise direction until needle bar (C) touches stop screw (D). Loosen screw (E) and set synchronizing gauge rod (F) so the flat end is on one of the lines in the center of the block (G). Tighten screw (E).

Turn the handwheel in the opposite direction until the needle bar touches stop screw (D, Fig. 9). Synchronizing rod (F) should come to the same line on block (G). The difference must not exceed one line.

If the setting cannot be achieved, main shaft coupling (A, Fig. 10) must be repositioned. Remove the crank chamber cover and gasket. Loosen the three coupling screws (B). If synchronizing rod (F, Fig. 9) moves more to the right while the handwheel is rotated in a clockwise direction, the looper is too fast and the main shaft should be retarded. If the rod moves more to the right when the handwheel is rotated in a counterclockwise direction the looper is too slow and the mainshaft should be advanced. Tighten screws (B, Fig. 10).

NOTE: If the stationary Knife interferes with the synchronizing rod (F) remove the knife to make the adjustment.

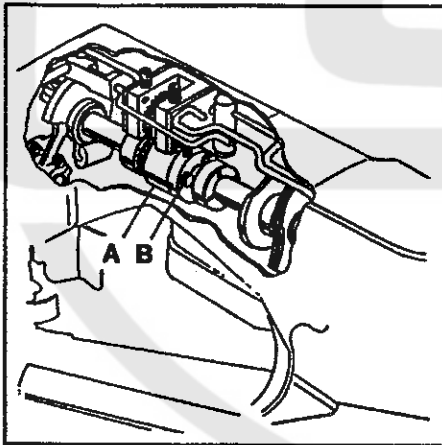

FIG. 10

If the looper and needle synchronizing gauge (21227CG) is not available, synchronization may be checked as follows. Check the needle bar height and looper gauge for accuracy. Insert the second and third needles. Clamp a collar on the upper portion of the needle bar to limit the downward stroke of the needle bar to stop within $5/32$ " (4.0mm) of its bottom stroke. If the machine is synchronized the looper point will be exactly the same with regard to the needles whether the handwheel is turned clockwise or counterclockwise.

LOOPER ADJUSTMENTS

Looper Alignment

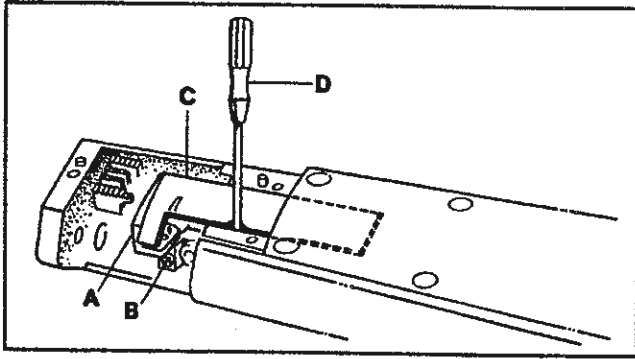

FIG. 11

The looper blade must be set at a 90° angle to the looper shaft. Insert looper (A, Fig. 11) into the looper holder and tighten screw (B). Place the narrow end of looper alignment gauge (C), no. 21227CU, in the feed bar slot. Insert a 1/8" diameter screwdriver (D) in the half circle cutout of the aligning gauge and press the right side of the feed bar slot and also against the looper blade. If the looper blade does not align with the end of the gauge, loosen screw (B) and reposition looper (A). Tighten screw (B).

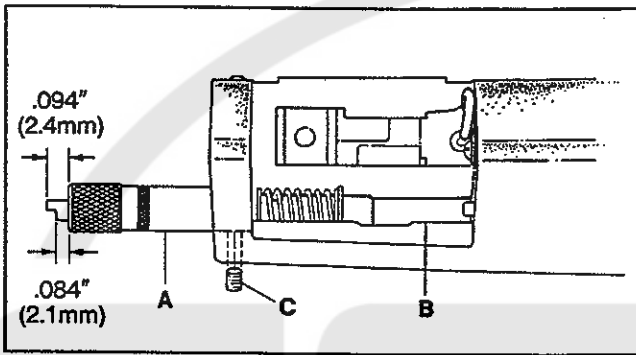

FIG. 12

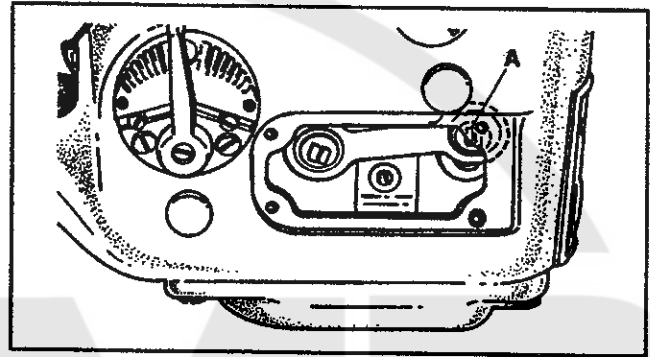

FIG. 13

Looper Avoid

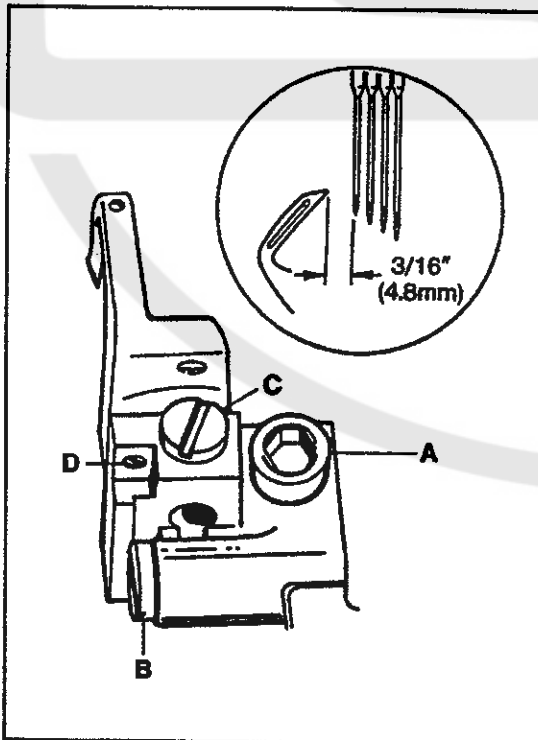

FIG. 14

The looper avoid is set at .094" (2.4mm). Using gauge no. 21227BV (A, Fig. 12), position looper shaft (B) fully to the rear (away from operator) and insert the gauge through the looper shaft hole in the end of the cylinder until the plunger is fully extended from the gauge. Tighten clamp screw (C). When the looper is positioned fully to the front, the end of the plunger should be flush with the end of the gauge. The motion of the plunger from the extended position to flush represents .094" (2.4mm) travel. If less looper avoid is required, use the other step on the gauge which is .084" (2.1mm). To adjust the looper avoid remove the cylinder cover and loosen screw (A, Fig. 13) with TI-85 wrench. Raise the ball joint to shorten the avoid motion or lower it to lengthen the avoid motion. Tighten screw (A). Reposition gauge (A, Fig. 12) and recheck the setting.

Looper Gauge

Turn the handwheel in operating direction until the looper has traveled fully to the left. Loosen screw (A, Fig. 14) and move the looper holder to the right or left until the distance from the point of the looper to the center of the first (left) needle is $3/16"$ (4.8mm). Clearance between the looper point and the scarf of the needle must not exceed $.002"$ (0.05mm). Turn screw (B) until the $.002"$ (0.05mm) dimension is achieved. Tighten screw (A).

Vertical Adjustment of Looper

A clearance of $.018"$ to $.025"$ (0.46mm to 0.64mm) should be maintained between the top of the looper and the bottom of the stitch tongue. Loosen screw (C, Fig. 14) and turn screw (D), directly under the looper, up or down as required. Make sure the looper is seated and tighten screw (C). Check for clearance.

SETTING THE FRONT NEEDLE GUARD

Install needle guard (A, Fig. 15) and position it to touch but not deflect the first needle. Slowly turn the handwheel in operating direction and check the needles to make sure they are not pinched between the looper and the needle guard.

SETTING THE FEED DOGS

Preliminary Setting:

Install the differential feed dog (A, Fig. 16) with screw (B). Attach rear needle guard (C) to main feed dog (D), pushing in fully to the rear and tighten screw (E). Install main feed dog with screw (F).

Loosen screw (G) and set the slot in feed bar eccentric stud (H) in a horizontal position. Tighten screw (G). At the highest point of travel feed dogs (A and D) should be the depth of one full tooth above throat plate (J). Loosen screws (B and F) and adjust the height of each feed dog by moving them up or down in the elongated slot of the shank. Tighten screws (B and F). Loosen screw (G) and turn stud (H) until the top of the feed dogs are parallel to the throat plate. Rotating stud (H) will simultaneously level both feed dogs.

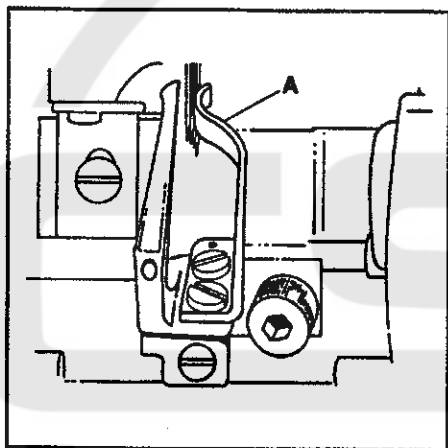

FIG. 15

Final Setting:

Both the main and differential feed dogs may be individually adjusted to height. Main feed dog (D) at its highest position should rise above the top of the throat plate the depth of one full tooth when the normal presser spring pressure is applied. The differential feed (A) may then be raised to it.

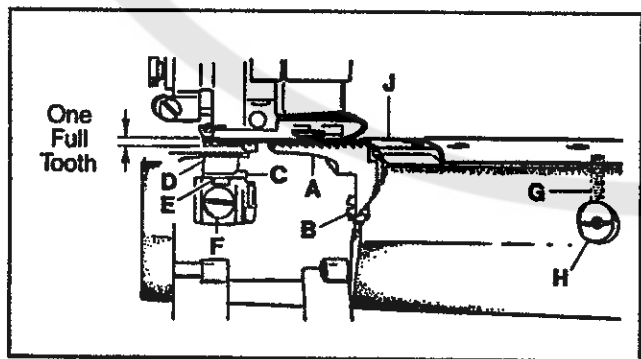

FIG. 16

SETTING THE REAR NEEDLE GUARD

Set rear needle guard (A, Fig. 17) so it clears the first (left) needle (B) by .002" to .003" (0.05mm to 0.07mm). Check the guard position to the other needles to avoid pinching. Loosen screw (C) and reposition guard (A) as necessary. Tighten screw (C).

SETTING THE STITCH LENGTH

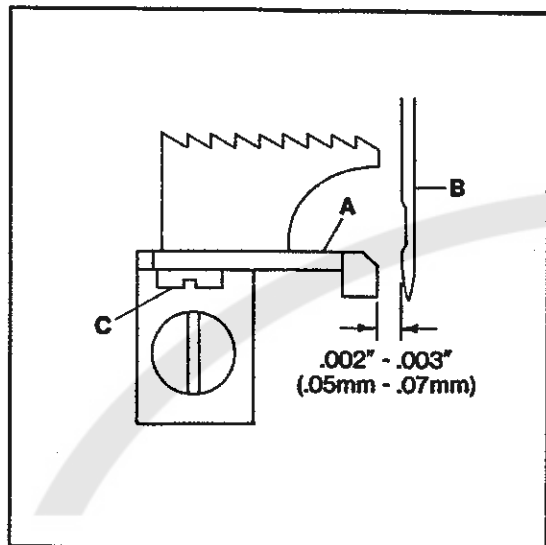

FIG. 17

This machine is designed to sew 10 to 16 stitches per inch. The normal factory setting is 12 stitches per inch. To change the stitch length remove the plug screw located directly above the cylinder side cover. Loosen screw (A, Fig. 18) in lever (B) and move up to increase the stitch length or down to decrease the stitch length. Tighten screw (A) and replace the plug screw.

CAUTION: If the stitch length is changed the rear needle guard setting must be checked and readjusted if necessary. Failure to do so may result in needle and/or parts breakage.

DIFFERENTIAL FEED CONTROL

The amount of differential feed is controlled by lever (C, Fig. 18). The adjusting plate is numbered from 1 to 9. When the lever is set from numbers 1 to 4 reverse differential or stretching occurs. The numbers from 4 to 5 produce equal feed stitching while numbers 5 to 9 produce a gathering stitch. The two stop screws (D) can be set to limit the movement of lever (C) or lock the lever in one position.

SETTING THE PRESSER FOOT

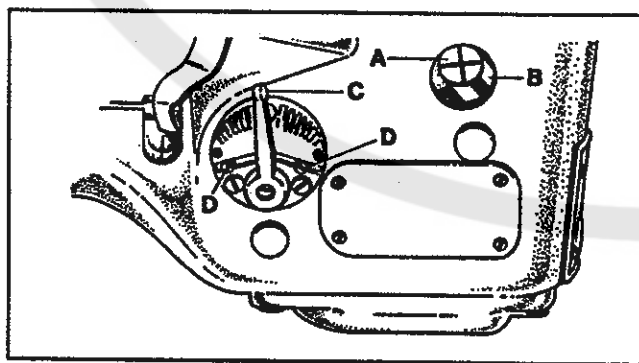

FIG. 18

Remove the presser bar regulating screw and the presser spring. Raise the needle bar to its highest position and remove the retainer. As the foot is slipped under the needles, swing the upper knife into the opening on the right side of the foot and slide the linkage onto the hook driving sleeve. Insert the presser bar through the linkage and into the presser foot shank. Tighten presser foot screw. With the presser bar inserted properly into the presser foot, position the foot left to right so the finger of cover thread carrier (A, Fig. 19) is between the first and second needles. Set presser bar guide (B, Fig. 19 Inset) so foot will not move. Set right presser foot guide (C) and left presser foot guide (D) to maintain

setting. Loosen presser bar guide screw (E Fig. 19 Inset) and check to see that foot has vertical freedom with no right to left play and no bind. Tighten presser bar guide screw (E).



SETTING THE PRESSER FOOT (CONT.)

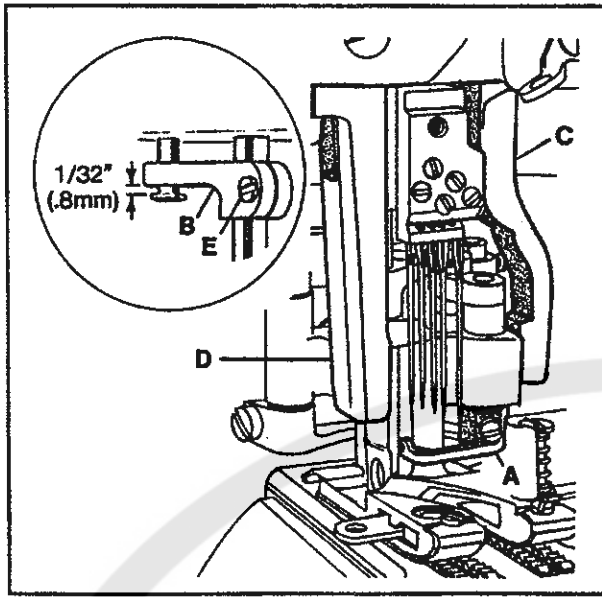

FIG. 19

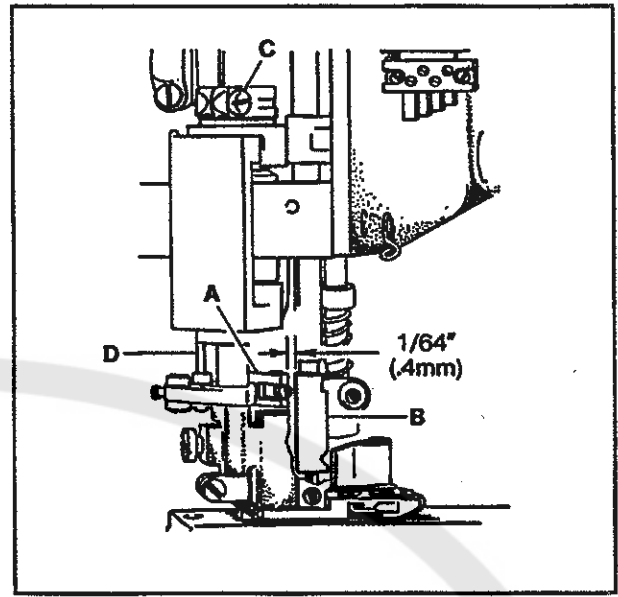

FIG. 20

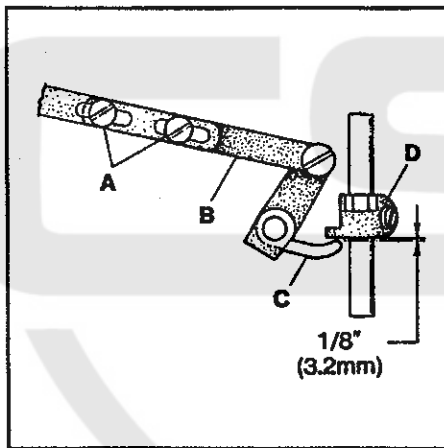

FIG. 21

Turn the handwheel in operating direction until link (A, Fig. 20) has traveled fully to the front. There must be a $1/64"$ (0.4mm) clearance between link (A) and the back of needle head (B) when link (A) starts to jackknife. Loosen screw (C) and rotate driving sleeve (D) to position link (A). Tighten screw (C).

Replace the presser spring and the presser bar regulating screw. Loosen screws (A, Fig. 21) in lifter lever link assembly (B) and position lever (C) so there is $1/32"$ (0.8mm) clearance between it and presser bar guide (D) when the feed dogs are below the throat plate.

Add the cover thread hook and cover thread carrier if they are not in place. Position carrier so the thread loop will be carried behind the first two needles. There should be a $1/64"$ to $1/32"$ (0.4mm to 0.8mm) clearance between the hook and the carrier at their closest position.

When the hook swings to the left it will pass over the cover thread. On its return travel, the thread will "pop" into the slot on the underside of the hook and is carried to the right. This thread forms a triangle for the third and fourth needle threads to pass through. As the cover thread "pops" into the slot it must cast-off the high point of take-up (A, Fig. 22) at the same time. Loosen the two screws in the cover thread take-up and reposition if necessary. If there is difficulty in making this adjustment, check the thread tension and make sure the hook point has an extremely high polish and the angle is correct. Due to clearance requirements bending the hook is not recommended.

SETTING THE PRESSER FOOT (CONT.)

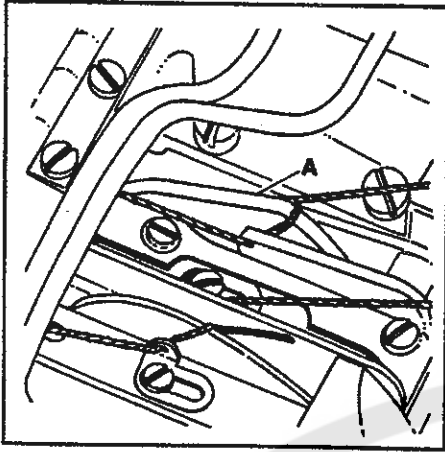

FIG. 22

Turn the handwheel in operating direction. As the third and fourth needles and retainer descend make sure they do not pierce or pick the loop on the hook because a malformed stitch will result. If the hook and carrier are too close together the thread may roll off the hook. Too much motion to the right will cause the retainer to deflect from the hook and strike the throat plate.

The presser foot lifter stop plunger must be set so the hook will not hit the bottom of the needle head as the presser foot is being lifted. Position the needle bar to its lowest point of travel. Loosen nut (A, Fig. 23) and turn plunger (B) clockwise until it strikes the crankshaft counterweight. While applying pressure to lifter (C) to lift the foot, back out of the plunger until the distance between the hook and the underside of the needle head is $1/64$ " (0.4mm) (see Fig. 24). Tighten nut (A, Fig. 23).

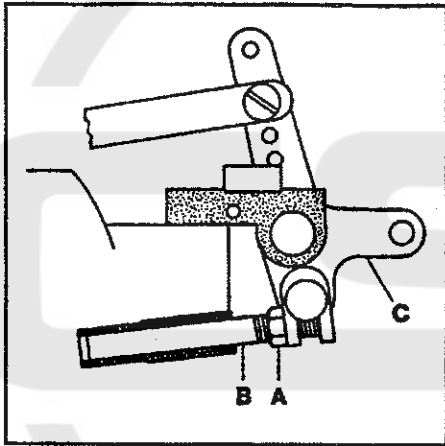

FIG. 23

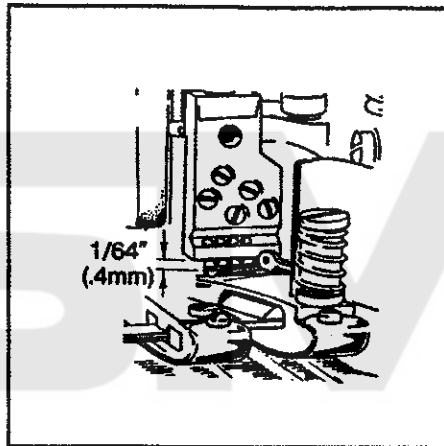

FIG. 24

To adjust the position and tension of frame chip guard (A, Fig. 25), slightly loosen screw (B) and turn washer (C) with 21388Y spanner wrench until spring (D) snaps the guard into the closed position. Tighten screw (B). A light resistance should be felt when opening the guard.

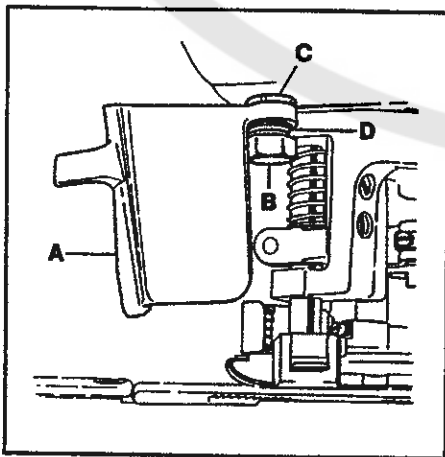

FIG. 25

Position the needle bar at the bottom of its stroke. Measure from the top of the needle bar to the top of the casting to obtain dimension "A" (see Fig. 26).

Position the needle bar at the top of its stroke. Measure from the top of the needle bar to the top of the casting to obtain dimension "B".

SETTING THE KNIFE DRIVE LEVER



SETTING THE KNIFE DRIVE LEVER (CONT.)

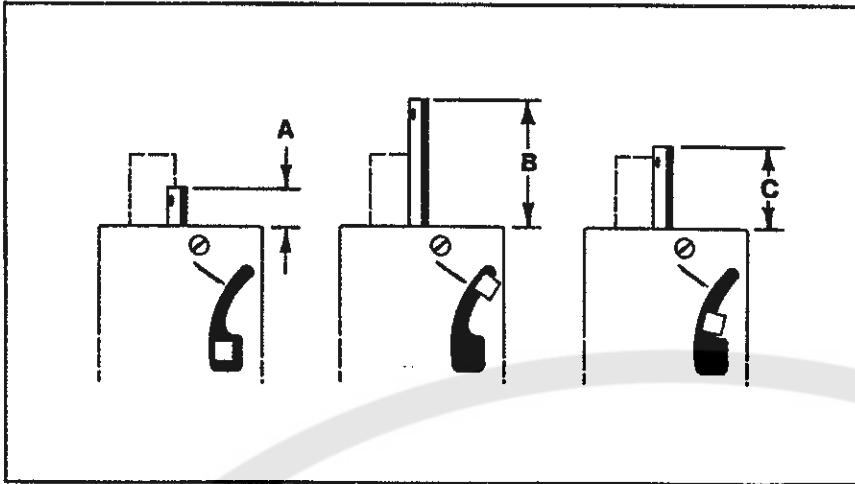

FIG. 26

Subtract dimension "A" from dimension "B" and divide by two. Add this number to dimension "A" to obtain "C". Set a caliper to the "C" dimension and turn the handwheel in operating direction until the height of the needle bar is at the "C" dimension. At this time the knife drive lever should be in the 6 o'clock position. If adjustment is necessary, loosen screws (A, Fig. 27) in the needle lever and reposition knife drive lever (B) to the 6 o'clock position. Tighten screws (A). The dimension between the centerline of right and left knife drive connection ball joints (C and D) must be $2 \frac{27}{32}$ " (72.2mm). Loosen left hand thread nut (E), right hand

thread nut (F) and turn connecting rod (G) until dimension is achieved. Tighten nuts (E and F).

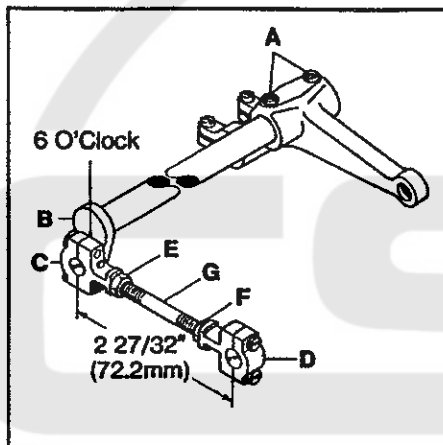

FIG. 27

SETTING THE TRIMMING KNIVES (STYLES 36200 AK, PA, PJ, PX, TA, TJ, TX)

To make the adjustments for a flat, butt seam, position lower knife (A, Fig. 28) in the foot so it extends $\frac{1}{32}$ " to $\frac{1}{16}$ " (0.8mm to 1.6mm) past the right side of the left toe (B) (approximately between the second and third needles). Loosen screw (C) and move knife in or out as required. Tighten screw (C) securely.

(STYLES 36200 PH, PM, TH, TM)

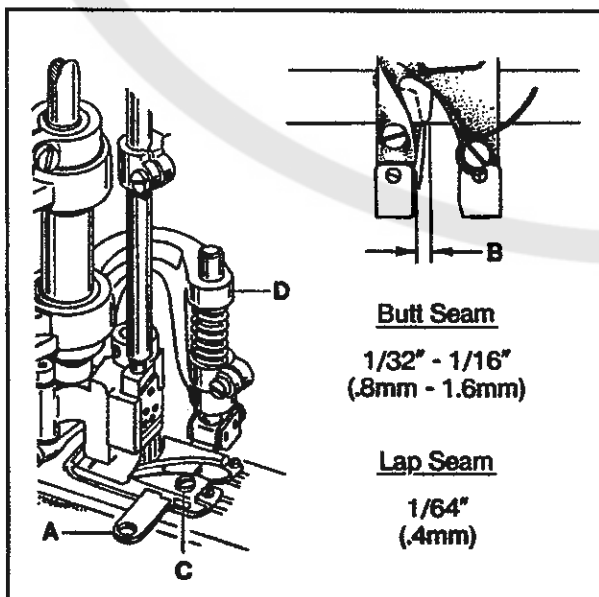

FIG. 28

To make the adjustments for a lap seam, position lower knife (A, Fig. 28) in the foot so it extends $\frac{1}{64}$ " (0.4mm) past the right side of the left toe (B) (approximately even with the first needle). Loosen screw (C) and move knife in or out as required. Tighten screw (C) securely.

(ALL STYLES)

Turn handwheel in operating direction until knife driving bracket (D) is positioned to the extreme left. At this time the front edge of both knives should be parallel with each other and the upper knife cutting edge should overlap lower knife cutting edge by $\frac{1}{64}$ " (0.4mm)

SETTING THE TRIMMING KNIVES (ALL STYLES) (CONT.)

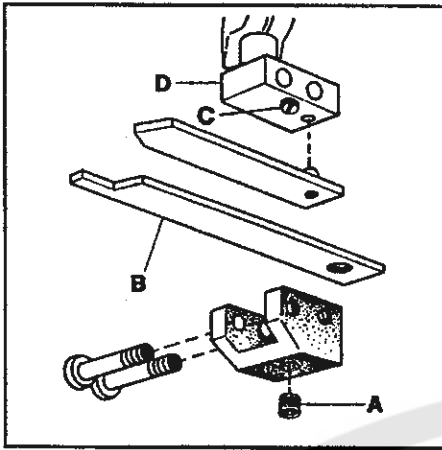

FIG. 29

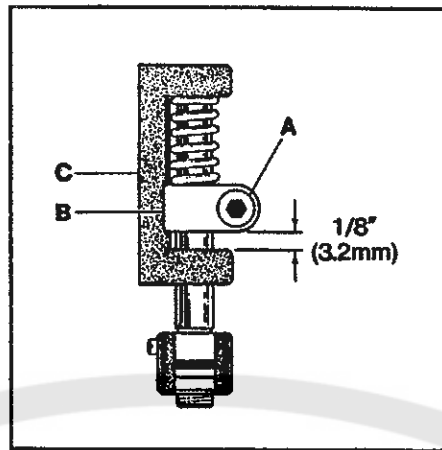

FIG. 30

If necessary loosen screw (A, Fig. 29) and move knife (B) to the right or left as required. Tighten screw (A).

If the shear angle between the knives has to be changed, raise or lower screw (C, Fig. 29) in knife holder shank (D).

To set spring pressure between the knives loosen screw (A, Fig. 30) and raise knife holder guide collar (B) 1/8" (3.2mm) from knife driving bracket (C). Tighten screw (A).

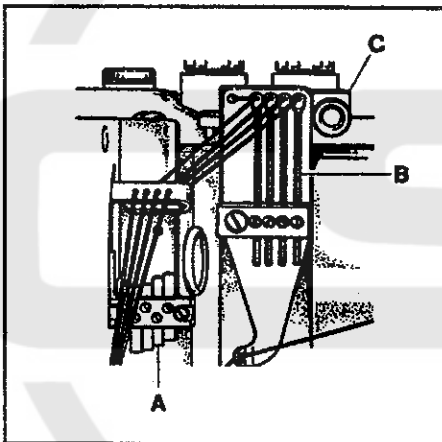

FIG. 31

NOTE:

More or less spring pressure may be required depending on the type of material being sewn. Also, both knives may have to be repositioned after a trial seam is made so there is an equal margin from the edges of the two plies to the center rows of stitching.

NEEDLE THREAD ADJUSTMENTS

Four needle thread strike-off pins (A, Fig. 31) are provided for independent needle thread control. Level the take-ups to the height of the thread in the needle lever eyelet at its lowest position. Raise the first take-up (nearest the operator) 1/8" (3.2mm) and the second take-up 1/16" (1.6mm). Further adjustment may be necessary to obtain proper needle loop size so skipped stitches may be avoided.

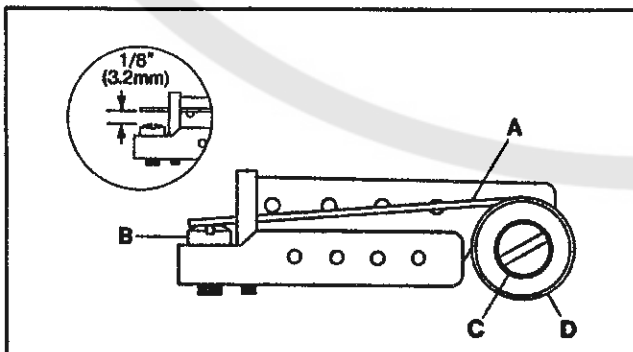

FIG. 32

Set the four frame needle thread eyelets (B, Fig. 31) eye with the eyelets in holder (C). Adjust as necessary so the needle thread loops around the looper will remain firm and not seek random positions when the needle bar descends.

Unlocking spring (A, Fig. 32) provides a proportional amount of pull-up of the needle threads when the machine is reversed for unlocking the stitch so the loops will not form on the front of the needles and become caught by the looper.

NEEDLE THREAD ADJUSTMENT (CONT.)

Turn screw (B) up or down so unlocking spring (A) will have $1/8"$ (3.2mm) drop from the bottom of the thread holes to the top of screw (B). Loosen screw (C) and turn knurled knob (D) to adjust the spring tension. Tighten screw (C).

Tension of the six threads is individually controlled. The needle tension is seldom uniform; the first needle thread having more tension than the other three. Use only enough tension to pull up the stitch. A well-balanced stitch will have the first and fourth needle loops pulled up and the second and third needle loops small and even.

LOOPER THREAD ADJUSTMENT

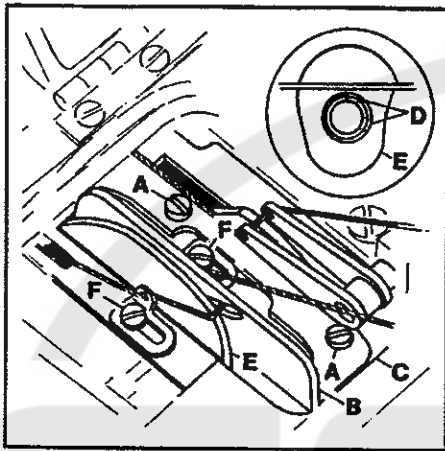

FIG. 33

Loosen screws (A, Fig. 33) and position looper thread cast-off (B) flush with the right end of cast-off support plate (C). Tighten screws (A). Loosen screws (D, Fig. 33 inset) and time take-up (E) so the thread will cast-off when the needle bar has descended $7/64"$ (2.8mm) from its highest position. When thread eyelets (F) are moved further to the left the amount of thread pull-off will increase.

COVER THREAD ADJUSTMENT

Loosen screw (A, Fig. 34) and set the lower edge of cover thread take-up eyelet (B) so it's $3/32"$ (2.4mm) above the surface of cast-off plate (C). Tighten screw (A). As the cover thread hook moves to the left over the cover thread and the needle bar starts to rise, the cover thread must "cast-off" from the high point of take-up (D). Loosen screws (E) and adjust take-up (F) accordingly. Make sure that take-up (F) is centered in cast-off plate slot (C) and take-up eyelet (B) is centered to take-up (F). Tighten screws (E).

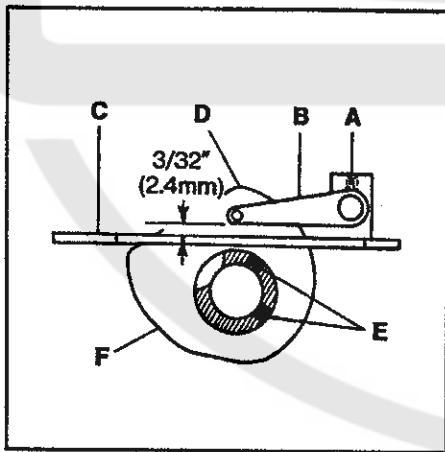

FIG. 34

TENSION RELEASE

The tension release should start to function when the presser foot has raised approximately $1/32"$ (0.8mm) above the surface of the throat plate and be entirely released when the presser foot has reached its highest position. Insert a large screwdriver into slot on the right end of shaft (A, Fig. 35), loosen screw (B) in lifter lever (C) and turn the screwdriver to raise or lower pins (D). Tighten screw (B).

NOTE:

Make sure the $1/32"$ (0.8mm) clearance between the presser bar lifter lever and presser bar guide has been maintained. Refer to Fig. 21 if readjustment is necessary.

HUNG FOOT ADJUSTMENT

Turn handwheel in operating direction until the feed dogs are below the throat plate surface. At this time there should be a $1/32"$ (0.8mm) clearance between the bottom of presser bar guide (A, Fig. 36) and presser bar guide stud (B). Loosen screw (C) and turn nut (D) as required. Tighten screw (C). When sewing on extremely lightweight material and/or feed cutting is a problem, the presser foot may be "hung" by raising stud (B) until guide (A) rests on the shoulder of stud (B). This adjustment will raise the presser foot slightly, so only the pressure of the presser foot shoes contact the material.

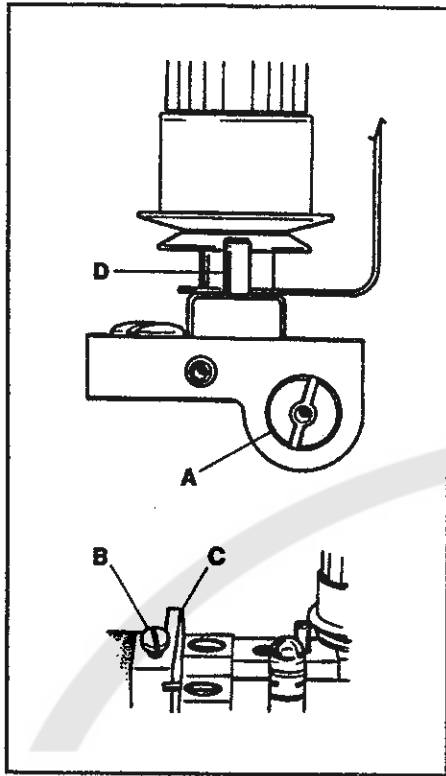

FIG. 35

SETTING THE LAP FORMER (STYLES 36200 PH, PM, TH, TM ONLY)

Attach gibs (A, Fig. 37) to the cylinder cover but do not tighten screws (B); leave them snug for further adjustment. Fasten spring (C, Fig. 37 inset) to the bottom of slide block (D) and insert between gibs (A). Attach lap former (E) to slide block (D) with screws (F) and position it in the center of the presser foot. Position the slide block so it has a snug (but not tight) fit the entire length of the gibs. Tighten screws (B).

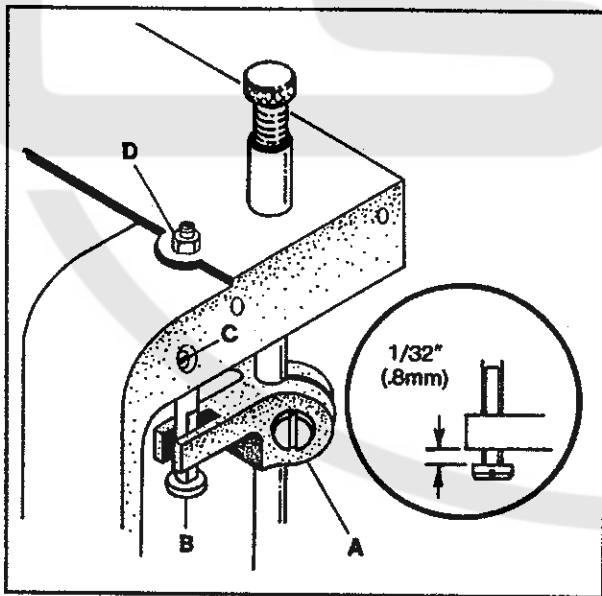

FIG. 36

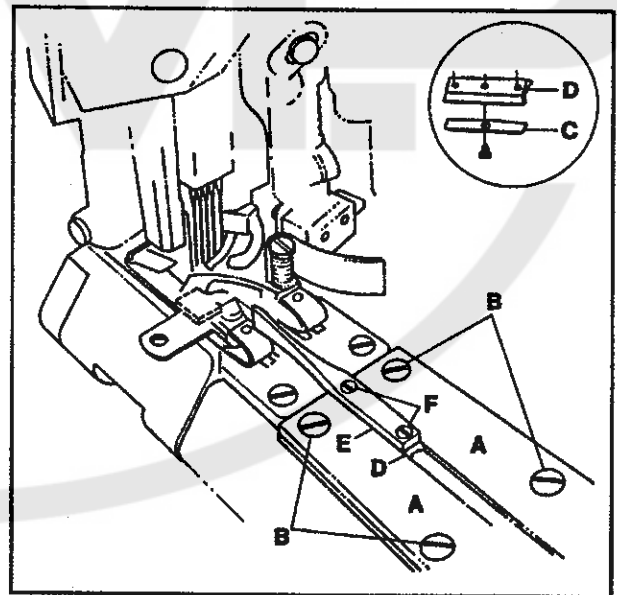
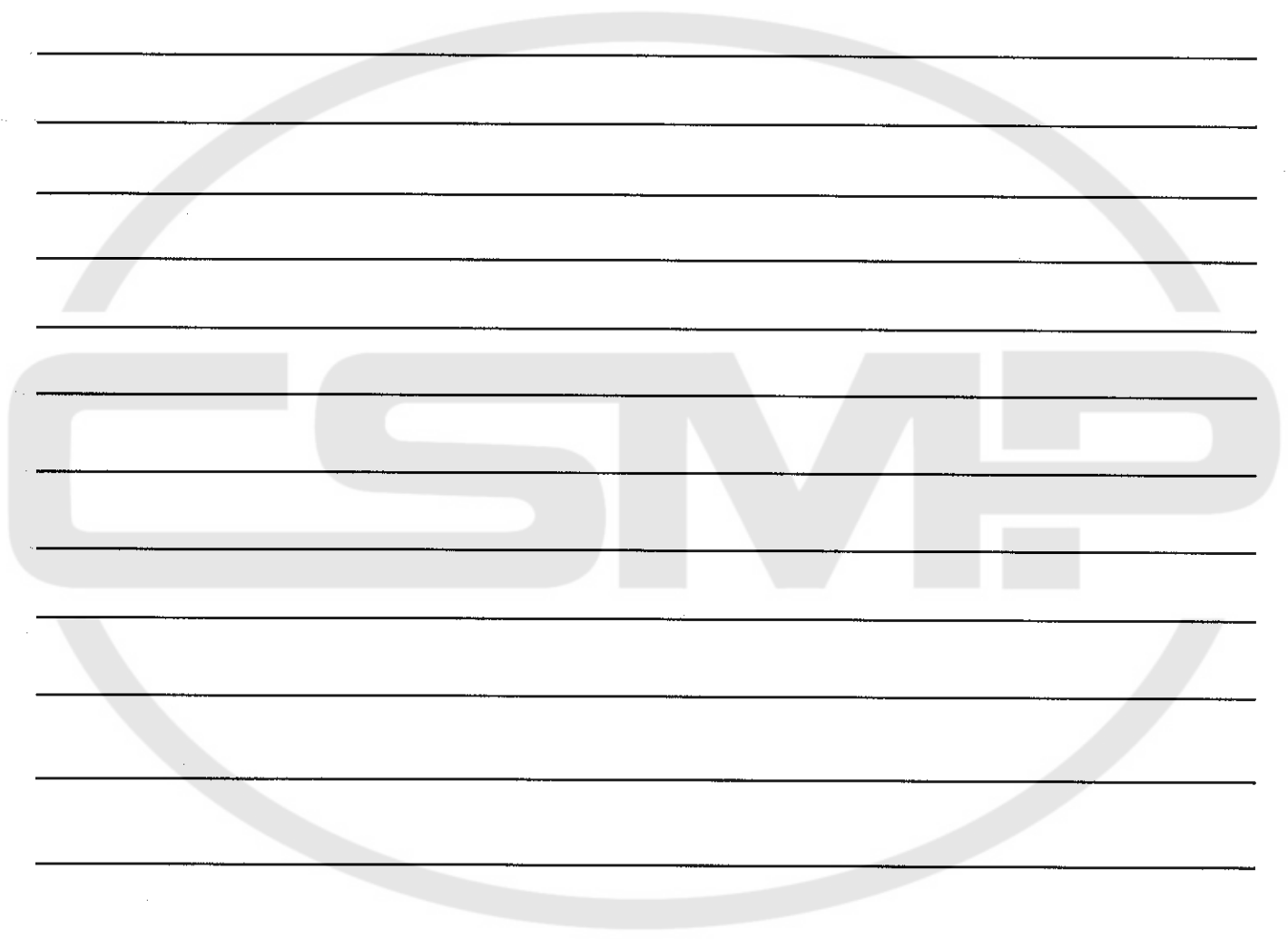

FIG. 37

NOTES





JUKI
Union Special