



Union Special[®]
INDUSTRIAL SEWING EQUIPMENT

STYLES

ADJUSTING INSTRUCTIONS AND
ILLUSTRATED PARTS LIST

39600CA

39600CB

39600CP

39600CQ

39600CR

39600CS

CLASS 39600
HIGH-STYLED HIGH SPEED
FOUR AND FIVE THREAD
SAFETY STITCH MACHINES

CATALOG

NO.

127N

SECOND

EDITION

CATALOG NO. 127N
INSTRUCTIONS
FOR
ADJUSTING AND OPERATING
LIST OF PARTS
CLASS 39600
FOUR AND FIVE THREAD SAFETY-STITCH MACHINES
STYLES

39600CA
39600CB
39600CP
39600CQ
39600CR
39600CS

SECOND EDITION

COPYRIGHT 1966

BY

UNION SPECIAL CORPORATION
RIGHTS RESERVED IN ALL COUNTRIES

PRINTED IN U.S.A.

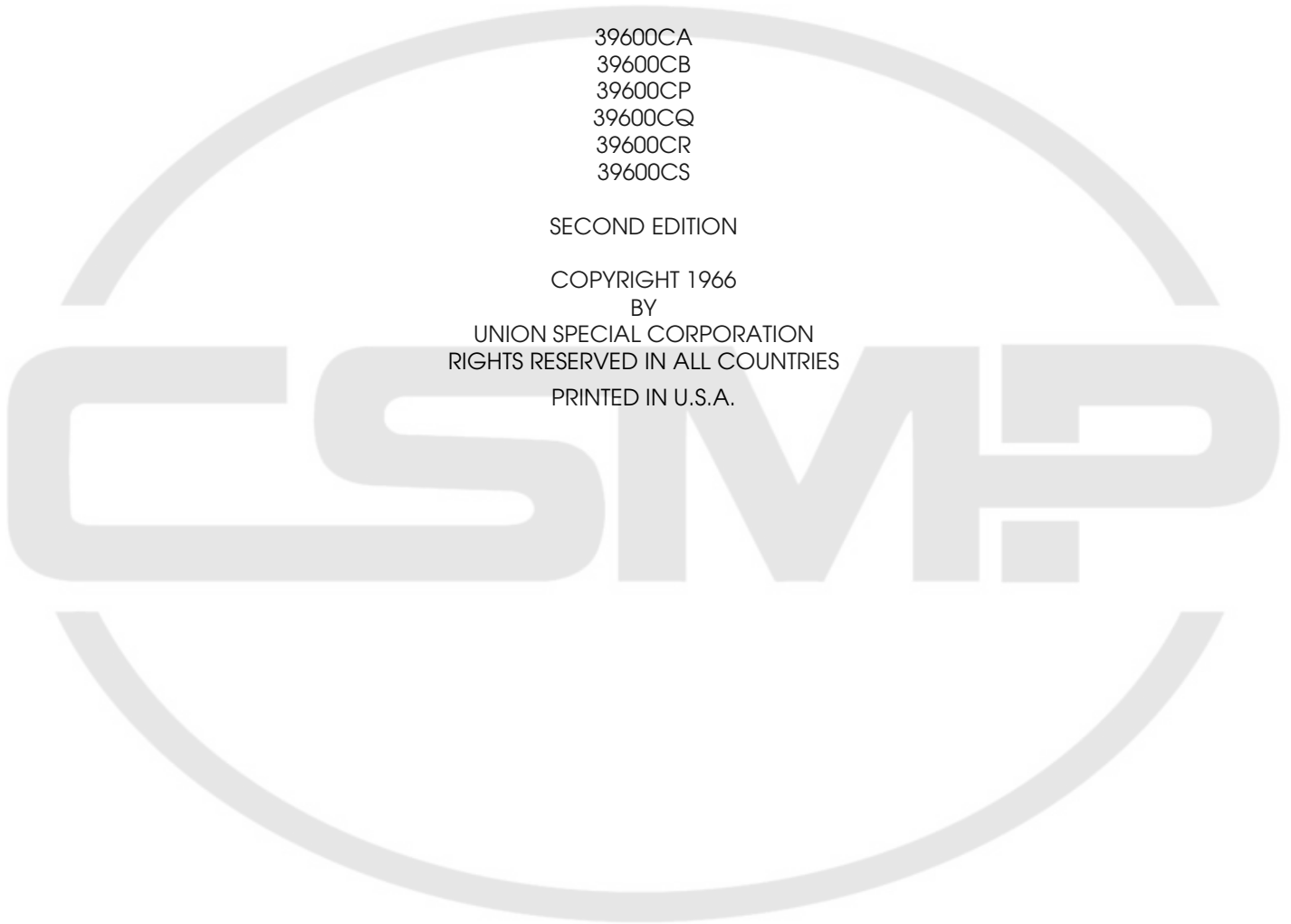

IDENTIFICATION OF MACHINES

Each UNION SPECIAL machine is identified by a Style number which is stamped into the name plate on the machine. Style numbers are classified as Standard and Special. Standard Style numbers have one or more letters suffixed but never contain the letter "Z". Example: "Style 39600 CA" Special Style numbers contain the letter "Z". When only minor changes are made in a standard machine, a "Z" is suffixed to the Standard Style numbers. Example: "Style 39600 CAZ".

Styles of machines similar in construction are grouped under a class number which differs from the style number in that it contains no letters. Example: "39600".

The distance between the rows of stitches or between the needles is represented by a gauge number measured in 1/64ths of an inch, going from left to right. The width of overedge is represented by a fraction. Collectively, the gauge number and the width of overedge represent the machine gauge. Example: 5-1/8". Thus, 5-1/8 gauge represents a distance of 5/64 inch between the left needle (401 stitch) and the right needle (503 or 504 stitch) and the 1/8 represents the width of overedge to the right of the right hand needle.

APPLICATION OF CATALOG

This catalog applies specifically to the Standard Styles of machines as listed herein. It can also be applied with discretion to some Special Styles of machines in this class. Reference to direction, such as right, left, front, back, etc., are given from the operator's position while seated at the machine. Operating direction of handwheel is away from operator.

STYLES OF MACHINES

Two Curved Needles, Left Needle in Front, Differential Feed, Light to Medium and Heavy Duty machines, Trimming Mechanism with spring pressed Lower Knife, Automatic Lubricating System.

39600 CA Two loopers, one spreader, four thread dual stitch; 401 double locked stitch on left needle and 503 two thread overedge stitch on right rear needle. Straight upper knife parts. Light to medium duty machine for simultaneously seaming and overedging on sport and dress shirts, ladies' blouses, street and house dresses, coat and jacket linings, pillow cases and similar operations on light to medium weight Durable Press or conventional materials. Seam specification, (401-503) 515-SSa-2; standard gauge and seam widths are 5-1/8 and 12-3/16; stitch range, 8 to 16 per inch; cam adjusted main and differential feeds. Maximum recommended speed 6500 R. P. M.

39600 CB Same as Style 39600 CA except three loopers, five thread dual stitch; 401 double locked stitch on left needle and 504 three thread overedge stitch on right rear needle. Seam specification (401-504) 516-SSa-2.

39600 CP Same as Style 39600 CA except medium to heavy duty, for operations on sport shirts, coat and jacket linings, slacks, jackets, shoulder pads and similar operations on medium to medium heavy weight Durable Press or conventional materials. Maximum recommended speed 6000 R. P. M.

39600 CQ Same as Style 39600 CP except three loopers, five thread dual stitch; 401 double locked stitch on left needle and 504 three thread overedge stitch on right rear needle. Seam specification (401-504) 516-SSa-2.

39600 CR Same as Style 39600 CA except medium to heavy duty and angular upper knife parts, for operations on slacks, jackets, sport shirts, jacket and coat linings, shoulder pads and similar medium to medium heavy weight materials. Maximum recommended speed 6000 R. P. M.

39600 CS Same as Style 39600 CR except three loopers, five thread dual stitch; 401 double locked stitch on left needle and 504 three thread overedge stitch on right rear needle. Seam specification (401-504) 516-SSa-2.

OILING

CAUTION! Oil was drained from machine when shipped, so reservoir must be filled before beginning to operate. Oil capacity of Class 39600 is seven ounces. A straight mineral oil of a Saybolt viscosity of 90 to 125 seconds at 100° Fahrenheit should be used.

Machine is filled with oil at spring cap in top cover. Oil level is checked at the sight gauge on front of the machine. Red bulb on oil level indicator should show between gauge lines when machine is stationary.

Machine is automatically lubricated. No oiling is necessary, other than keeping main reservoir filled. Check oil daily before the morning start; add oil as required.

The oil drain plug screw is located at the back of machine near bottom edge of base. It is a magnetic screw designed to accumulate possible foreign materials which may have entered the crank case. It should be removed and cleaned periodically.

NEEDLES

Each UNION SPECIAL needle has both a type and size number. The type number denotes the kind of shank, point, length, groove, finish and other details. The size number, stamped on the needle shank, denotes largest diameter of blade, measured in thousandths of an inch, midway between shank and eye. Collectively, type and size number represent the complete symbol which is given on the label of all needles packaged and sold by Union Special.

Two needles having different lengths are used in this machine. The shorter needle for the overedge stitch, located at the right, is Type 154 GAS. It is a round shank, round point, curved blade, standard length, single groove, struck groove, spotted, chromium plated needle and is available in sizes 055/022, 065/025, 070/027, 075/029, 080/032, 090/036, 100/040, 110/044, 125/049, 140/054, 150/060.

The longer needle for the 401 stitch, located at the left, is Type 158 GJS. It is a round shank, round point, curved blade, flat tapered blade, Class "B" length, double groove, struck groove, long spot, government point, chromium plated needle and is available in sizes 070/027, 075/029, 080/032, 090/036, 100/040, 110/044, 125/049.

To have needle orders promptly and accurately filled, an empty package, a sample needle, or the type and size number should be forwarded. Use description on label. A complete order would read: "1000 Needles, Type 154 GAS, Size 080/032".

Selection of proper needle size is determined by size of thread used. Thread should pass freely through needle eye in order to produce a good stitch formation.

Success in the operation of UNION SPECIAL machines can be secured only by use of needles packaged under our brand name, *Union Special*®, which is backed by a reputation for producing highest quality needles in materials and workmanship for more than three-quarters of a century.

CHANGING NEEDLES

Release pressure on presser foot by turning the presser foot release bushing (A, Fig. 1) and swinging presser arm (B) out of position. Turn handwheel in operating direction (away from operator) until needle holding screws (A, Fig. 2) are just exposed from behind presser spring plunger (B) and accessible to screwdriver. Loosen screw and withdraw needle. When replacing needles observe the position of the flat which is at the left of the shank and be sure the needle is inserted the full depth to the combination eyelet and stop plate (C).

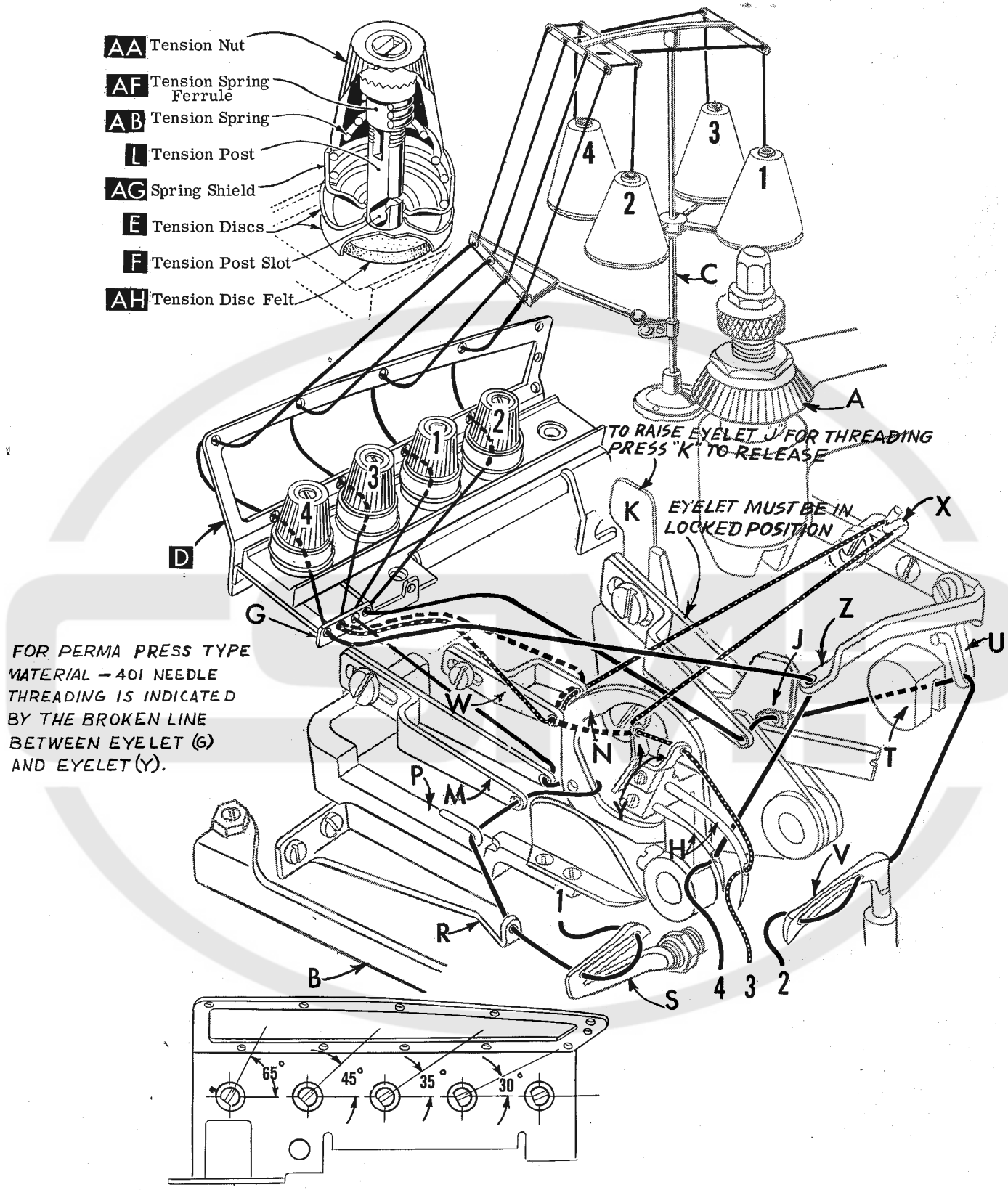

Fig. 1

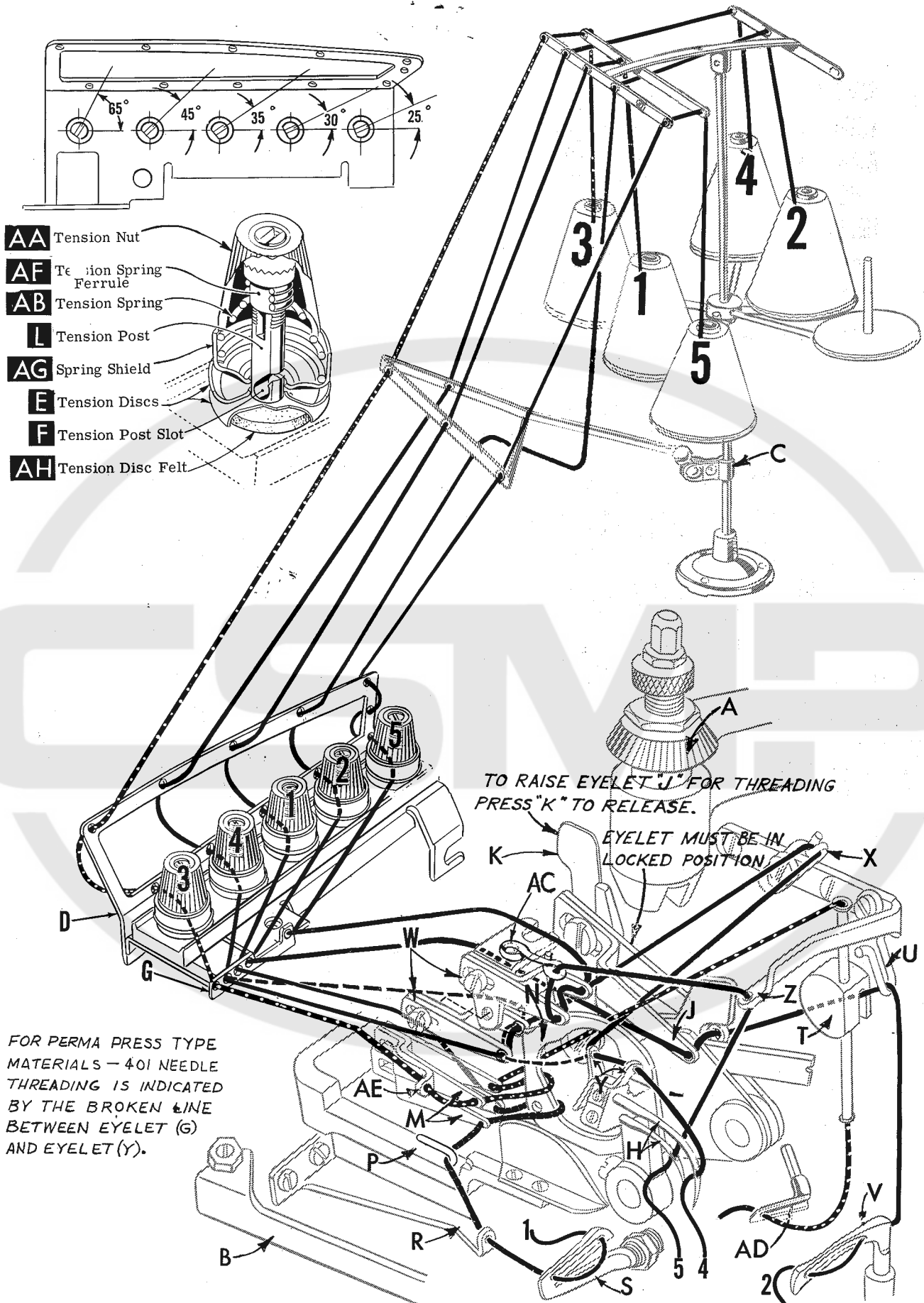

Fig. 1A

THREADING

Only parts involved in threading are shown in threading diagrams (Fig. 1 and 1A). Parts are placed in their relative positions for clarity.

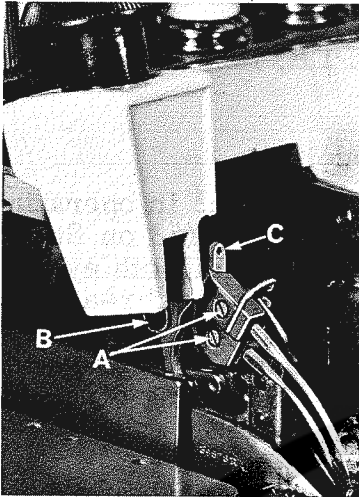

Fig. 2

Thread from thread stand (C) is threaded through the upper holes of tension thread guide (D) from front to back and then through the lower holes from back to front. It should be noted on Styles 39600 CB, CQ and CS that thread #5 (overedge needle-green color code) is threaded through the tension thread guide (D), first through the upper hole back to front, second through the middle hole front to back and third through the lower hole back to front. All threads then continue between the tension discs (E), through tension post slot (F) in tension post (L) and on through its proper hole in front thread guide (G).

It will simplify the threading of machine to follow the recommended sequence as designated by the numbers assigned to each thread, starting with thread No. 1, then No. 2, etc. The various eyelets and guides on the machine for each thread have been color coded to further aid the threading process.

Thus the sequence for Styles 39600 CA, CP and CR (503 stitch) is as follows: Thread No. 1, lower looper thread, yellow color code; thread No. 2, 401 looper thread, blue color code; thread No. 3, 401 needle thread, red color code, thread No. 4, overedge needle thread, green color code.

The sequence for Styles 39600 CB, CQ and CS (504 stitch) is as follows: Thread No. 1, lower looper thread, yellow color code; thread No. 2, 401 looper thread, blue color code; thread No. 3, upper looper thread, black color code; thread No. 4, 401 needle thread, red color code; thread No. 5, overedge needle thread, green color code.

Before beginning to thread, swing cloth plate open, turn handwheel in operating direction until the needles (H) are at their highest position, release pressure on presser foot by turning presser foot release bushing (A), and swing presser arm (B) out of position.

RAISE 401 LOOPER THREAD TAKE-UP EYELET (J) BY RELEASING EYELET LATCH (K) AND RAISING EYELET

THREADING LOWER LOOPER (Thread No. 1-Yellow Color Code)

Double end of lower looper thread (#1) and lead it through both eyes of lower looper thread eyelet (M) from right to left. NOTE: Thread must pass through the inside of needle thread cam pull-off (N). Lead thread back under hook of fabric guard bracket (P) and through eye of frame looper thread guide (R). Turn handwheel in operating direction until heel of lower looper (S) is all the way to the left; then thread through left eye, entering from the rear, and then through the right eye entering from the front. Left eye of lower looper can be threaded easily if tweezers are held with the left hand.

THREADING 401 LOOPER (Thread No. 2-Blue Color Code)

Double end of 401 looper thread (#2) and lead it through both eyes of looper thread take-up eyelet (J) from left to right, when the eyelet is in raised position. Return eyelet to its lower position by pressing it down. When eyelet is in correct position, latch will snap into place. Pass thread under knife arm, into groove of the upper knife support block (T), and over hook (U). Bring needle arm to bottom of its

THREADING 401 LOOPER (Thread No. 2-Blue Color Code) (Continued)

stroke. Insert double end of thread in right eye of 401 looper (V) and push through an inch or so of thread. Holding tweezers in left hand insert doubled end of thread into left eye, using about 3/16 inch projection of thread from point of tweezers. DO NOT THREAD LOOPER WITH NEEDLE LOOP AROUND LOOPER. REMOVE LOOP, OTHERWISE MACHINE WILL NOT SEW.

THREADING 401 NEEDLE (Red Color Code)

Lower needle arm to bottom of its stroke, by turning handwheel in operating direction. Threading from left to right, pass the 401 needle thread (#3 on Styles 39600 CA, CP and CR; #4 on Styles 39600 CB, CQ and CS) through both eyes of needle thread pull-off eyelet (W), passing over the outside of the needle thread cam pull-off (N). Then thread through eyelet (X) from back to front, through the top eye of needle driving arm thread eyelet (Y), through lower eye and finally through the eye of the left needle (H). Raise needle by rotating handwheel in operating direction and thread needle from front to back.

NOTE: When sewing light weight perma press type material, thread should pass through both eyes of needle thread pull-off eyelet (W) from right to left, then through both eyes of eyelet (Y) and finally through the needle.

THREADING OVEREDGE NEEDLE (Green Color Code)

Turn handwheel in operating direction until the needle is at its highest position. Pass overedge needle thread (#4 on Styles 39600 CA, CP and CR) under overhanging arm of top cover and down through hole in top cover needle thread eyelet (Z). Thread needle (H) from front to back.

On Style 39600 CB pass overedge needle thread (#5) under overhanging arm of top cover, through both eyes of the upper needle thread pull-off eyelet (W), from right to left, passing over the outside of the needle thread cam pull-off (N), then down through hole in top cover needle thread eyelet (Z). Thread needle (H) from front to back.

On Styles 39600 CQ and CS, pass overedge needle thread (#5) under overhanging arm of top cover, through both eyes of the upper needle thread pull-off eyelet (W), from right to left, passing over the outside of the needle thread cam pull-off (N), then thread through eyelet (AC) from right to left and then down through hole in top cover needle thread eyelet (Z). Thread needle (H) from front to back.

THREADING UPPER LOOPER (Black Color Code)

Turn handwheel until point of upper looper (A) is all the way left. Double end of upper looper thread (#3 on Styles 39600 CB, CQ and CS) and lead the thread through the auxiliary looper thread eyelet (AE) from back to front, then through both eyes of upper looper thread eyelet (M) from left to right. NOTE: Thread must pass through the inside of needle thread cam pull-off (N). After pulling up upper looper thread tube assembly (T), lead thread under overhanging arm of top cover and down through thread tube assembly (T). Pull thread out bottom of tube; push tube down and then insert thread through upper looper eye from front to back.

THREAD TENSION

The amount of tension on the needle and looper threads is regulated by the knurled tension nuts (AA, Fig. 1). Tension on the threads should be only enough to secure proper stitch formation. Using a postal scale, the measurements are taken with the needles at the top of their stroke and pulled in the direction as indicated. As a start the tensions may be as follows:

THREAD TENSION (Continued)

401 needle thread; 1 oz. straight out of lower eye of needle arm eyelet (Y).

Overedge needle thread; 1 to 1 1/2 oz. straight out of thread guide (G).

401 looper thread; 1 1/2 to 2 oz. straight out of looper thread eyelet (U).

Lower looper thread; 4 to 4 1/2 oz. straight out of frame looper thread guide (R).

Further refinement in tension adjustment is discussed at the conclusion of the adjusting instructions.

PRESSER FOOT PRESSURE

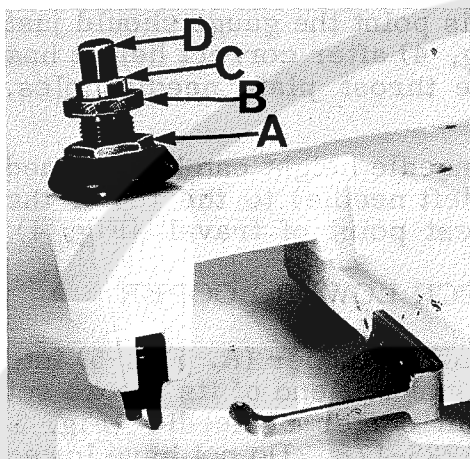

Fig. 3

Sufficient pressure to feed work uniformly should be maintained. Should it be necessary to increase or decrease amount of pressure on presser foot loosen lock nut (A, Fig. 3) and turn the adjusting screw (B). Adjusting screw has a right hand thread so tightening increases the pressure, loosening decreases pressure. When pressure adjusting screw (B) has been properly set, tighten lock nut (A). With presser foot resting on the throat plate, position locking nut (C) so that its under surface is approximately 1/32 inch to 1/16 inch from the top surface of adjusting screw (B). Set the cap (D) against the locking nut (C).

FEED ECCENTRICS

Feed eccentrics used in these machines have been selected to produce approximately 11 stitches per inch on Styles 39600 CA and CB and 10 stitches per inch on Styles 39600 CP, CQ, CR and CS. It will be noted that part numbers 39540 B-10 and 39540 B-11 for Styles 39600 CA and CB, and 39540 B-9 and 39540 B-10 for Styles 39600 CP, CQ, CR and CS are the main feed and differential feed eccentrics respectively. Minor numbers of the part symbol indicate approximately the number of stitches obtainable when using that eccentric. Unless otherwise specified, machine will be shipped with above eccentrics.

Generally speaking, differential (right hand) feed eccentric determine the number of stitches produced; the main (left hand) feed eccentric is selected in relation to the degree and direction of stretch of material being sewn, or the type of operation.

The following stitch number feed eccentrics are available under No. 39540 B; 4, 5, 6, 7, 8, 9, 10, 11, 12, 13, 14, 15, 16, 18, 20, 22, 24, 26, 28, 30, 32, 34, 36, 40. Only two eccentrics are supplied with each machine. Additional eccentrics may be ordered separately. To order an eccentric, use No. 39540 B with a minor number suffixed to indicate number of stitches desired. Example: "39540 B-10".

ASSEMBLING AND ADJUSTING SEWING PARTS

It is suggested that the following sequence be followed: Before assembling the sewing parts, remove cloth plate, fabric guard, chip guard, upper knife assembly and lower knife holder assembly.

SETTING THE NEEDLES

Release the pressure on presser arm and swing arm out of position. Insert both needles (Type 158 GJ for the 401 stitch and Type 154 GAS for the overedge stitch) into the left and right holes, respectively, of the needle driving arm (A, Fig. 4), so that the butt ends contact the stop plate. Secure needles in this position with clamp screws (A, Fig. 2).

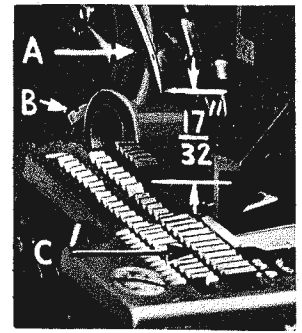

Fig. 4

With throat plate assembled in position, the needles should center in the throat plate needle holes. To align the needles, loosen clamp screw (B, Fig. 4) and move needle driving arm to the left or right as required. Gauge No. 21227 CR should be used to set the needle driving arm at the correct height. To use this gauge remove the left needle (401 stitch) and insert the gauge in its place. Be sure gauge seats against the stop plate. Turn the handwheel until needle driving arm is at its lowest position, at this point the gauge should just contact the throat plate. Tighten clamp screw (B, Fig. 4) after correct height has been obtained and needles have been centered in the throat plate needle holes. Remove throat plate.

If gauge No. 21227 CR is not available the correct needle height can be obtained by measuring $17/32$ inch from the 401 needle point (left needle) to the top of the throat plate, when needle driving arm is at its highest point of travel (Fig. 4).

SETTING 503 STITCH LOWER LOOPER

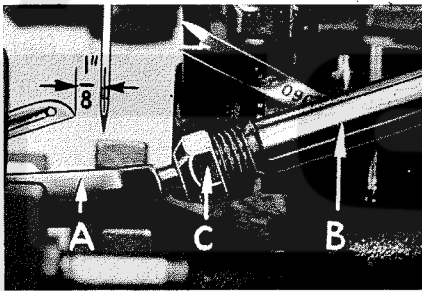

Fig. 5

Insert the 503 stitch lower looper (A, Fig. 5) into bar (B). With lower looper at left end of its stroke set looper point $1/8$ inch from center of needle (Fig. 5) using looper gauge No. 21225- $1/8$. Do not have lower looper deflecting needle. Do not lock looper nut (C) because the looper point will have to be set to the needle scarf after the rear needle guard has been assembled and positioned. (See paragraph under "Final Setting of Lower Looper.")

SETTING 503 STITCH REAR NEEDLE GUARD

Set the rear needle guard (A, Fig. 6) as high as possible without interfering with either the lower looper or movement of the lower knife holder, but still in position to deflect the needle forward $.002$ to $.004$ inch. Screw (B) is used to set rear needle guard. Make sure there is no interference between rear needle guard and lower looper.

FINAL SETTING OF 503 STITCH LOWER LOOPER

Now finish lower looper adjustment. As lower looper moves to the right its point should be set into the needle scarf (A, Fig. 7) until the needle springs forward from the rear needle guard surface another $.002$ to $.004$ inch. This setting is obtained by rocking the looper forward or backward around its shank. Recheck the $1/8$ inch looper gauge setting and tighten nut (C, Fig. 5).

SETTING 503 STITCH FRONT NEEDLE GUARD

Assemble front needle guard (C, Fig. 6). When lower looper is springing needle off back guard, set front needle guard as close as possible to needle without touching. Screw (D) is used to adjust and set front needle guard. After this setting make sure there is no interference between needle guards and differential feed dog.

SETTING 503 STITCH SPREADER

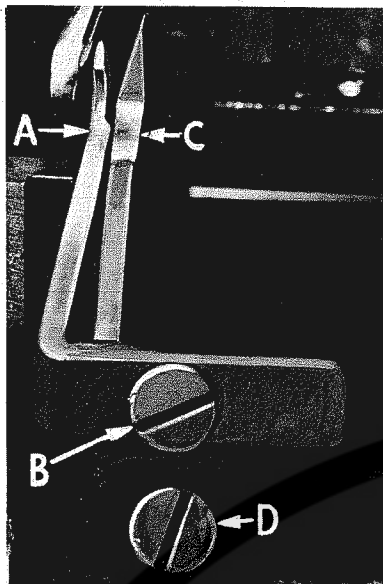

Fig. 6

Insert spreader (A, Fig. 8) in its holder. Screw (B) holds the spreader in its holder and permits spreader to be pushed in or out, or turned around its shank. Screw (C) on the collar holds spreader holder in the shaft, and allows the holder to be rotated or adjusted laterally.

Preliminary Setting: When spreader is at the right end of its stroke, spreader holder should be set to position the spreader shank about vertical (Fig. 8). The top end of the spreader shank should extend approximately $5/64$ inch above holder (Fig. 8).

Set spreader to pass just behind eye of lower looper, with approximately $.002$ inch clearance between spreader and lower looper (Fig. 9).

Next, turn handwheel until spreader is at left end of its travel: check the setting so lower point of spreader extends about $5/32$ inch to the left of needle (Fig. 10).

Now check setting between spreader and needle. If needle rubs the back of spreader, pull spreader out of its holder slightly and rotate the spreader holder forward a short distance. These same adjustments, in opposite movement, will reduce the clearance between spreader and needle. Reset to lower looper (Fig. 9).

SETTING 401 STITCH REAR NEEDLE GUARD

Insert rear needle guard into the hole in the throat plate support bracket. Set height of guard (A, Fig. 11) approximately $1/4$ inch below the throat plate seat. Bring the 401 needle down until its point is $1/64$ inch below the widest portion of the guarding surface. Then bring the guard forward to deflect the needle forward from $.003$ to $.005$ inch. Then lock the guard in place with set screw (B, Fig. 11).



Fig. 7

SETTING 401 STITCH LOOPER

Insert 401 stitch looper into looper holder and press down until the butt end of the shank strikes the looper shaft. Looper will be at correct height. Tighten the looper clamp screw while working looper point to and fro to secure accurate seating of clamp screw against flat on shank.

With looper at right end of its stroke, set looper $3/64$ inch from center of needle (Fig. 12) using looper gauge No. 21225-3/64. Loosen looper holder binder screw with a $7/64$ inch hexagonal allen key to position the looper.

Looking at left end of machine, set the looper point to lie in the scarf of the needle within $.002$ inch clearance (Fig. 13).

While hand turning machine through cycle observe the action of the needle with relation to the looper. As needle rises from bottom of its stroke the looper will approach the needle from right side and pass behind at top of needle

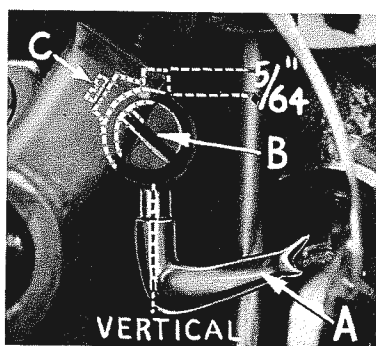

Fig. 8

SETTING 401 STITCH LOOPER (Continued)

scarf without striking. Further rising of the needle will result in the looper point entering the scarf. Furthermore, since the needle point is coming off the rear guard the needle will resume its normal position by moving to the rear, resulting in a close relation of the needle and looper, or actual contact, until scarf passes looper. On the down stroke the needle should pass behind the looper without the point glancing off the guarding surface of the looper.

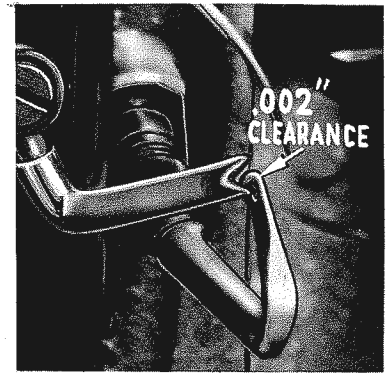

Fig. 9

Set front needle guard as close as possible to the needle when looper point is behind the needle and flush with the left side of needle. Also, front needle guard should be set so there is from $1/64$ to $1/32$ inch clearance between it and bottom of looper blade. Turn handwheel in operating direction, making complete revolutions to check whether needle is disturbed or pinched.

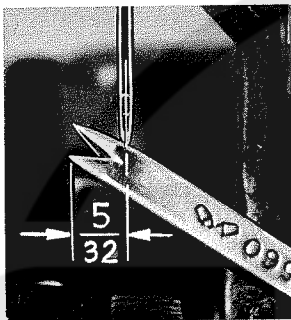

Fig. 10

For convenience the looper may now be threaded as shown in Fig. 1 and as described under paragraph "To Thread 401 Looper". Replace differential feed dog, throat plate, lower knife holder and reset upper knife. Check cutting action with thread.

SETTING THE FEED DOGS

Assemble main and differential feed dogs (A, B, Fig. 14).

Feed dogs should be leveled with the throat plate surface by rotating feed tilting adjusting pin (D). This pin raises or lowers the back end of feed bar. Feed dogs should be set level at the time teeth first appear above the throat plate. Screw (E) locks the feed tilting adjusting pin in place. Now set feed dogs at highest point of travel. Main and differential feed dog teeth should be set $3/64$ inch above the throat plate.

SETTING THE LOWER KNIFE

Replace lower knife holder assembly. In replacing lower knife holder assembly, tighten screw (A, Fig. 15) so that when the face of the flange on sleeve (B) seats against throat plate mounting bracket (C) a free lateral motion of the lower knife and holder assembly is obtained when the knife is manually pressed at its upper corner. Lower knife (D) should be set with cutting edge flush with throat plate surface. Adjustments are made with hexagonal head screw (E) which holds the lower knife. Lower knife is spring pressed against the upper knife, so no lateral adjustment is necessary when the width of trim is changed.

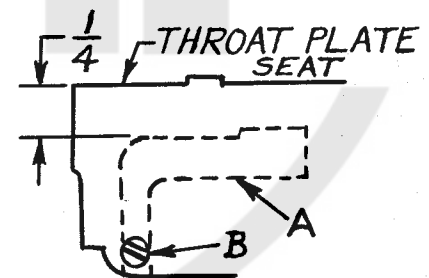

Fig. 11

Lower knife may be secured in any position by tightening screw (F) against the knife holder shaft. Set the desired width of trim by measuring from the right edge of lower knife to needle. Lock lower knife holder shaft with screw (F).

SETTING THE UPPER KNIFE (Styles 39600 CA, CB, CP and CQ)

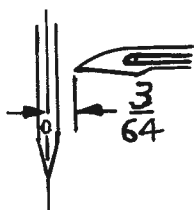

Fig. 12

Replace upper knife assembly. Clamp upper knife (G, Fig. 15) in position, setting allen screw (H) to hold clamp (J) against the upper knife. At bottom of its stroke, front cutting edge of upper knife should extend not less than $1/64$ inch below cutting edge of the lower knife.

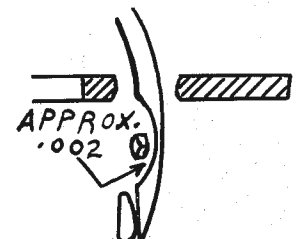

Fig. 13

SETTING THE UPPER KNIFE (Continued)

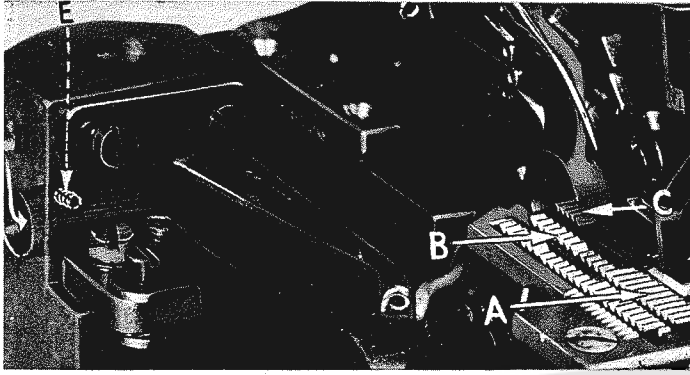

Fig. 14

knife should extend not less than 1/64 inch below cutting edge of lower knife. The chain guard (K) should be set down against the upper knife and slightly back from the cutting edge.

After upper knife has been set for proper width of trim, screw (L) should be tightened to lock upper knife holding block (M) in place. This will simplify resetting when upper knife is replaced.

After upper knife has been set for proper width of trim, screw (K) should be tightened to lock upper knife holding block (L) in place.

SETTING THE UPPER KNIFE (Styles 39600 CR and CS)

Replace upper knife assembly. Clamp upper knife (G, Fig. 15 A) in position, setting nut (H) to hold clamp (J) in its most clockwise position against upper knife. At bottom of its stroke, front cutting edge of upper

SETTING THE STITCH LENGTH

Length of stitch is determined by the combination of feed eccentrics used. The outer (left) eccentric (A, Fig. 16) actuates the main (rear) feed dog, while the inner (right) eccentric (B) actuates the differential (front) feed dog.

In assembling feed eccentrics, be sure hubs are facing each other. Be careful not to damage shaft or key. Tighten nut (C) securely. Be sure wool yarn in oil tube (F) touches feed eccentric connections.

To change feed eccentrics, remove nut and washer (C) from end of shaft (D). Turn handwheel in operating direction until key slot in eccentric is toward front. Using hooked eccentric extractor (E), supplied with machine, reach behind eccentric as shown and withdraw eccentrics. It may be necessary to move handwheel back and forth slightly during extraction.

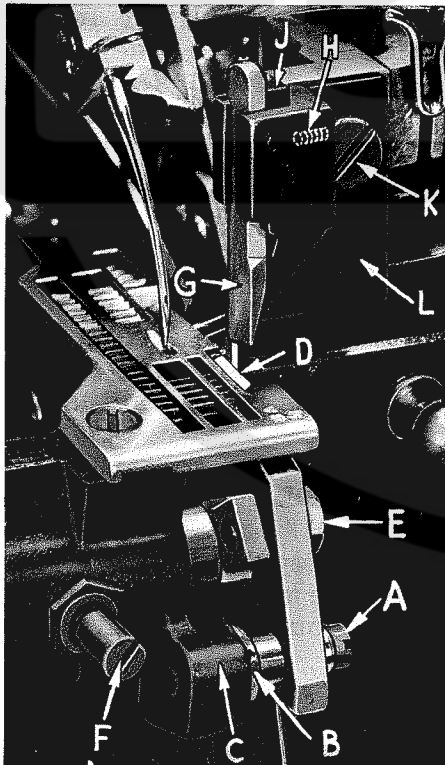

Fig. 15

If eccentrics are unusually tight fitting, in addition to removing nut (C, Fig. 17) from shaft (D) it may be helpful to remove nut (G) and feed driving connection (H). Then continue as originally suggested.

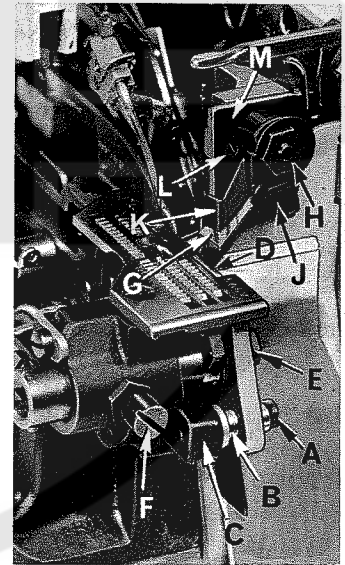

Fig. 15A

SETTING THE PRESSER FOOT

Assemble the presser foot to presser arm. With needle in high position, swing presser arm into sewing position and set the presser foot to align needle holes (front and back) and flat on throat plate. The front edge of needle hole in presser foot must be aligned with front edge of needle hole in throat plate. It is also important that the bottom of the presser foot be flat on the throat plate. To change presser foot setting loosen screw (A, Fig. 18) and move foot forward or backward on presser arm as required to align needle holes, or move foot left or right around presser arm until foot is flat on throat plate. Retighten screw. If necessary, presser foot can be realigned with throat plate slots by shifting the foot lifter lever shaft (H, Fig. 19). To move the shaft, loosen collar screws (B, Fig. 19) and clamp screw (G) and then shift the foot lifter lever shaft to the left or right as required. Retighten collar screws and clamp screw.

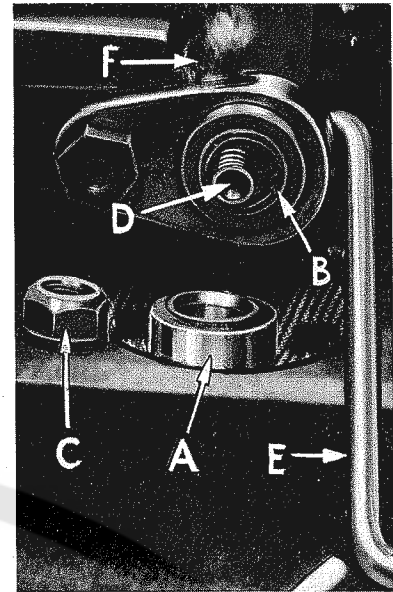

Fig. 16

The foot lifter lever arm (A, Fig. 19) and the collar (B) secure the shaft. Be sure the presser arm does not bind and rise when presser foot release bushing is unlocked.

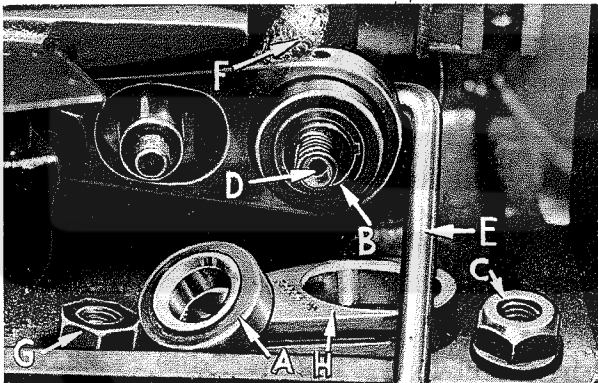

Fig. 17

the top of needle stroke, thread should be just tight enough to feed chain off stitch tongue. The stitch tends to pull down slightly if excessive thread is pulled on the up stroke.

Adjust lifter lever stop screw (C) so that presser foot can be raised no higher than upper spreader will permit: then lock the nut (D). There should be from 1/16 to 1/8 inch free motion of foot lifter lever before the presser foot begins to rise. This adjustment should be made with screw (E) and locked with nut (F). Reassemble the chip guard, fabric guard and cloth plate.

503 STITCH NEEDLE THREAD CONTROL

While sewing on material, check needle thread control as follows: Usually all needle thread is drawn on needle down stroke. At

503 STITCH LOWER LOOPER THREAD CONTROL

With material under presser foot, set lower looper thread eyelet (M, Fig. 1) back and down far enough so the thread is a little slack when the spreader reaches its extreme left position. Looper thread eyelet (M) should be about horizontal.

Frame looper thread guide (R) should be set with its eyelet approximately 1/8 inch to the right of the heel eyelet of looper (S) at the time the lower looper is at extreme left end of its travel.

THREAD TENSIONS

Before proceeding, balance both tensions to give a normal appearing stitch. Moderate change in these tensions will not markedly affect the purl.

SPECIAL ADJUSTMENTS

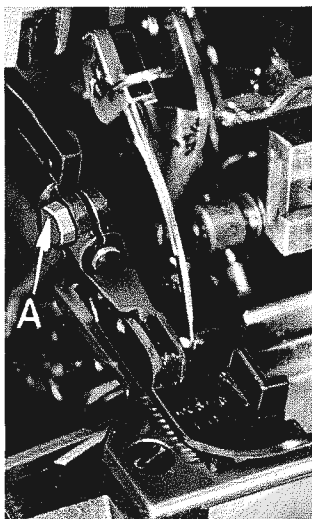

Fig. 18
ing the stitch.

SKIPPING: For occasional skipping, check and/or adjust as outlined below:

1. Recheck lower looper - needle setting. See "Setting the Needle", page 10.
2. Recheck spreader - lower looper crossing. See "Setting The Spreader", page 11.
3. Check clearance between needle and spreader. See that spreader moves far enough left past the needle.

Settings 1 and 2 should be made quite carefully. If it can be determined by appearance that skip is definitely not a needle loop skip, reposition looper thread eyelet (M, Fig. 1) by lowering it slightly and bringing eyelet holes in close to bend in looper thread pull-off (N). After this change, increase the looper thread tension as much as possible without distort-

CAUTION! As stated before, the looper thread must be slightly slack as spreader reaches its extreme left position or stitch will appear tight on the top side.

STARTING TO OPERATE

Be sure the machine is threaded according to threading diagram (Fig. 1, page 5 or Fig. 1A, page 6).

With thread tensions light, set looper thread eyelet (M) about horizontal and in the middle of its front to back location.

Operate machine slowly, with presser foot in place. Make sure chain forms and moves off the tongue freely.

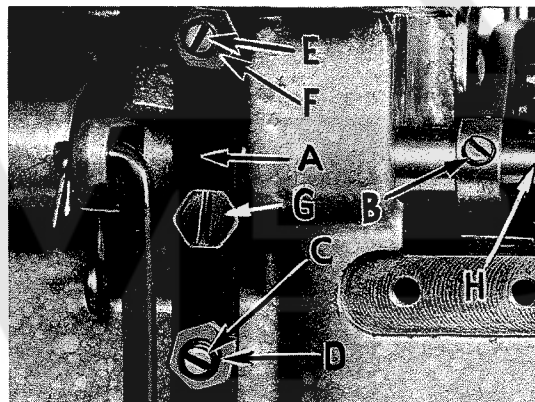

Fig. 19

SETTING 401 NEEDLE THREAD EYELETS

Bring needle thread through its respective eyelets as shown in Fig. 1 or 1A, and as described in paragraph "To Thread 401 Needle". Do not thread the needle. Lower needle to bottom of its stroke. Position needle thread pull-off eyelet (W, Fig. 1) so that the thread is far enough forward to bow the needle thread slightly. When the needle arm is at the top of its stroke, the needle thread will clear the pull-off cam by about 1/32 inch. Thread needle from front to back.

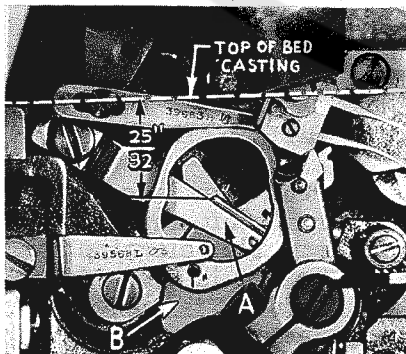

Fig. 20

SETTING 401 LOOPER THREAD EYELETS

If looper thread casting-off point has not been timed refer to the paragraph "Timing 401 Stitch Looper Thread Cast-off". Set the looper thread cast-off eyelet (A, Fig. 20) so that its top surface is flush with the pull-off

SETTING 401 LOOPER THREAD EYELETS (Continued)

surface of the looper thread take-up cam (B) when the needle is at the top of its stroke. Maintain this flush condition and set eyelet as far back as possible (Fig. 21). Pull several feet of thread through the looper to provide slack while checking the tension. Turn handwheel in operating direction until the needle is totally raised. Pulling the thread straight toward the operator, over the looper thread eyelet, adjust tension with the knurled nut (AA, Fig. 1) to 1 1/2 to 2 ounces.

SEWING OFF 401 STITCH

Final adjustments to the 401 stitch are made while hand turning the machine and observing the stitch formation. Insert two narrow plies of material under presser foot and observe formation of the needle loop upon the rising of the needle. Adjust the needle thread take-up eyelet (W, Fig. 1) by raising or lowering it until the loop formation is as shown in Fig. 22. The loop should not touch the front guard of the overedge needle, yet be round and full. At full speed the loop will tend to become less. To lower the eyelet tap left side; to raise eyelet bring needle arm to top position and insert wide blade screwdriver under eyelet and, using needle arm as support, twist screwdriver to the left. A slight movement, of 1/64 inch or less, will usually produce the desired result. Then retighten the eyelet holding screw.

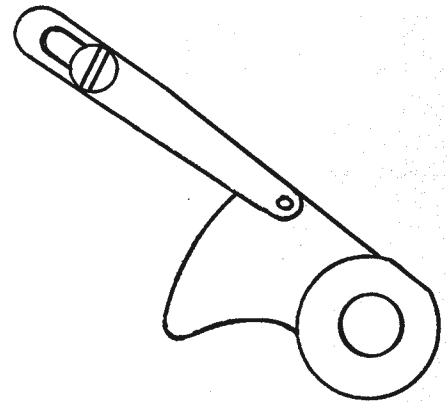

Fig. 21

Needle thread is drawn from the cone on the down stroke only and at two separate times. Thread is first drawn at the high point of the cam as shown between the marks (A, Fig. 23). The second time, needle thread is drawn just before the needle reaches the bottom of its stroke.

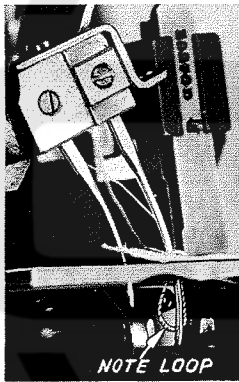

Fig. 22

Observe the action of the looper thread take-up at the bottom of the needle stroke. The looper thread is lying

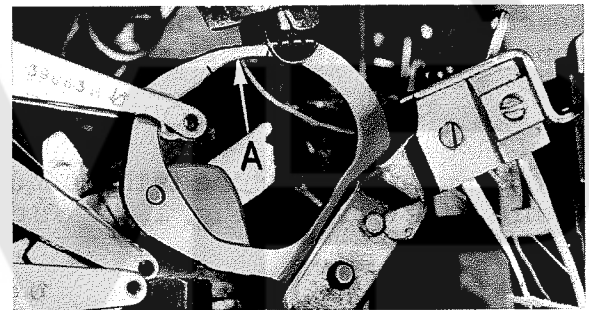

Fig. 23

across the cam lobes, slack from the previous casting-off. As the needle arm rises to the top, the looper thread will begin to tighten across the cam

until at the end of the rise, casting-off will again occur and the looper thread will lie in the crotch of the cast-off blade.

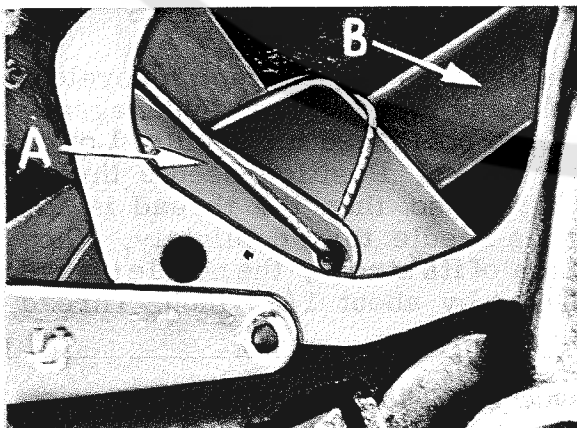

Fig. 24

Only enough tension should be carried in the looper thread to resist friction of looper and eyelet system. Thread should be pulled off only during the return travel of the looper from left to right and cease at casting-off.

TIMING 401 STITCH LOOPER THREAD CAST-OFF

When the 401 looper thread cam is correctly positioned on the needle arm shaft the cast-off corner will be 25/32 inch vertically below top surface of the bed when the needle arm is in its highest position (Fig. 20). This adjustment is made at the factory, but if checked and moved, it must be observed that the cam functions as a thrust collar for the needle arm shaft and correct thrust must be maintained. If this setting is correct the casting-

off may be timed. On the down stroke of the needle looper thread should be cast-off when the point of the needle is at the surface of the throat plate. To change the time of casting-off, move the cast-off blade (B, Fig. 24) up or down, rotating it about its holding screw.

Below is a list of the additional parts necessary to convert Style 39600 CA (503 stitch) to Style 39600 CB (504 stitch), Style 39600 CP (503 stitch) to Style 39600 CQ (504 stitch), or Style 39600 CR (503 stitch) to Style 39600 CS (504 stitch).

*NOTE: On five thread machine styles such as 39600 CQ or CS, when the 401 needle thread passes through eyelet (X) it is necessary to pass the 504 needle thread through eyelet (AC) to separate the 401 and 504 needle threads.

<u>Part No.</u>	<u>Description</u>	<u>Amt. Req.</u>
87 U	Screw, for needle thread pull-off eyelet, No. 39663 H-----	1
376 A	Screw, for upper looper thread eyelet, No. 39568 L-----	1
8372 A	Washer, for thread tension post-----	1
21101 H-6	Thread Stand, complete-----	1
29477 HU	Upper Knife Driving Arm Thrust Block and 504 Upper Looper Thread Tube, for Style 39600 CB-----	1
29477 JZ	Upper Knife Driving Arm Thrust Block and 504 Upper Looper Thread Tube, for Style 39600 CQ-----	1
39508 A	Upper Looper-----	1
39568 E	Auxiliary Eyelet, for 504 upper looper-----	1
39568 L	Upper Looper Thread Eyelet-----	1
39592 Y	Upper Looper Tension Nut, black-----	1
39592 AD	Thread Tension Disc-----	2
39592 AR-4	Tension Spring, for upper looper-----	1
39592 AF	Tension Disc Felt-----	1
39592 AH	Nut, for thread tension post-----	1
39592 AJ	Spring Shield-----	1
39592 AK	Tension Spring Ferrule-----	1
39592 AL	Thread Tension Post-----	1
39663 H	Needle Thread Pull-off Eyelet, for 504 needle thread-----	1
43139 A	Nut, for screw No. 376 A-----	1
*22849 A	Screw, for overedge needle thread eyelet, No. 52958-----	1
*52958	Overedge Needle Thread Eyelet-----	1

ASSEMBLING AND ADJUSTING SEWING PARTS FOR 504 STITCH

The setting and adjustment of the needles, lower looper, front and rear needle guards as described earlier for the 503 stitch are applicable when making similar adjustments for the 504 stitch. Also, the adjusting and setting of the upper looper used in the 504 stitch formation is similar to the setting of the spreader used in the 503 stitch formation. The exception or difference being the measurement of the 5/32 inch dimension from the center line of the needle to the lower point of the 503 stitch spreader (Fig. 10). The 504 stitch measurement is taken from the center of needle to the point of the upper looper (Fig. 10A). The measurement for either the spreader or the upper looper to be taken when they are at the left end of travel.

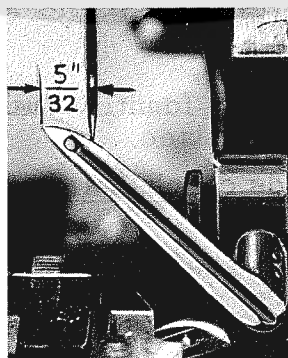

Fig. 10A

TO REMOVE CRANKSHAFT

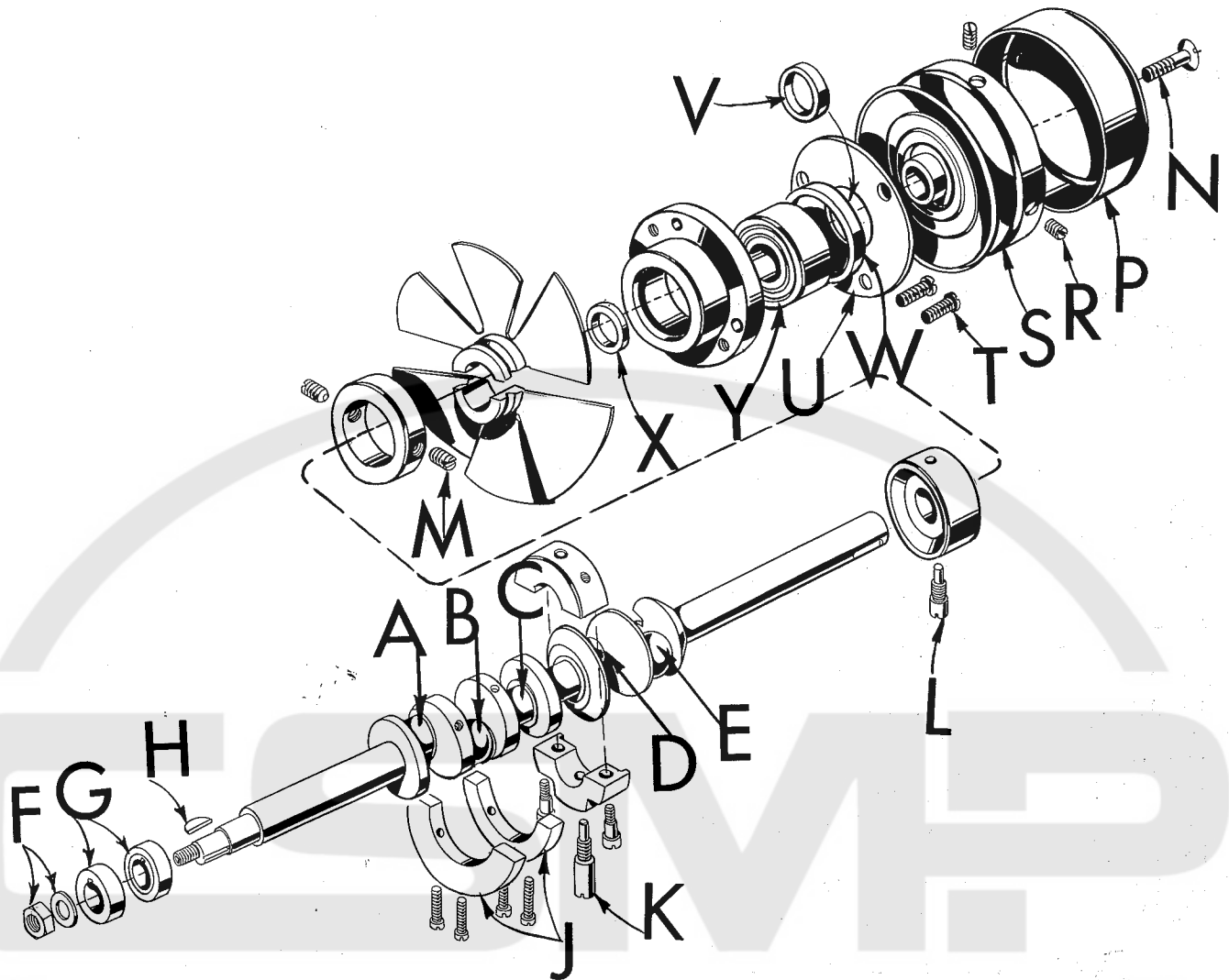

Fig. 25

Crankshaft can be withdrawn more easily if these steps are followed:

1. Drain oil by removing plug screw located on back of machine near bottom edge of base.
2. Remove top and bottom covers of machine.
3. Remove the feed eccentric nut and washer (F, Fig. 25) and, with the aid of the eccentric extractor, slip off the eccentrics (G).
4. Remove key (H).
5. Remove two counterweights (J). Identify these counterweights so that they will be reassembled in the proper place.
6. Remove screw (K) which holds crankshaft split bearing. This screw is reached through bottom of bed casting.
7. Remove caps of bearings on crankshaft at points A, B, D and E. When re-assembling bearing caps make sure they are in their original position. Trade-marks are stamped on both halves of the caps and both trademarks should be on the same side of the bearings. Also, screws should be reassembled in the same holes from which they were removed.

TO REMOVE CRANKSHAFT (Continued)

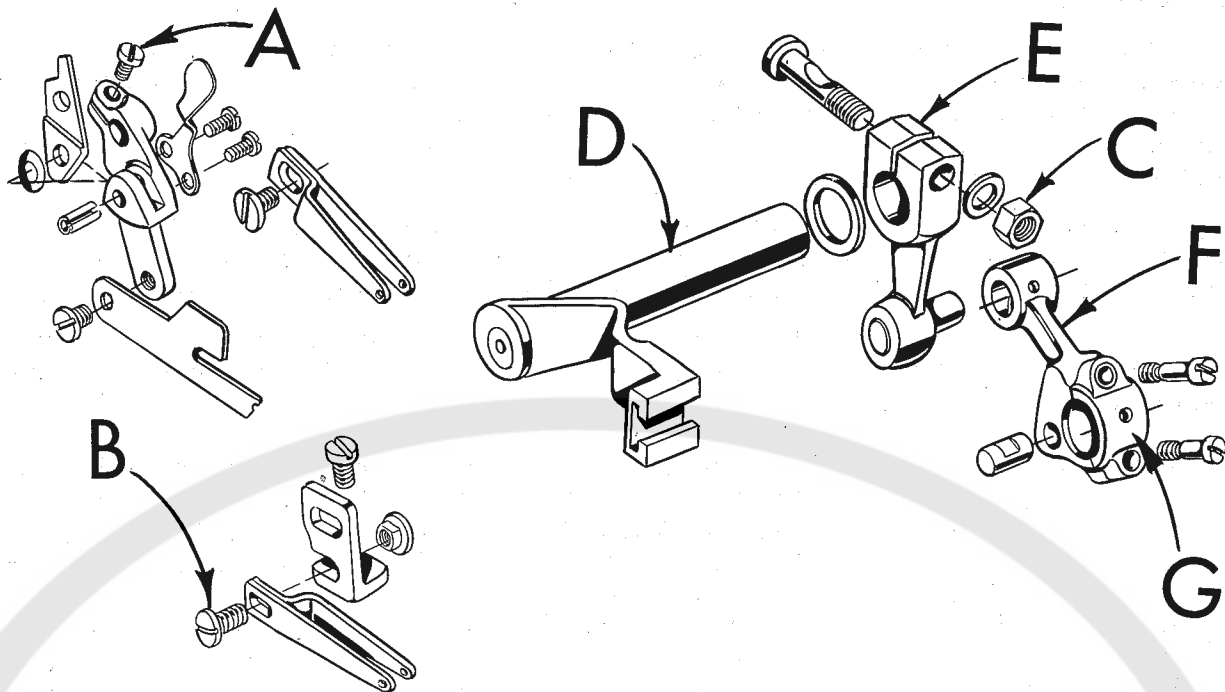

Fig. 26

8. Loosen clamp screw (A, Fig. 26) which holds eyelet bracket and swing bracket up. Loosen screw (B); swing eyelet up. Loosen clamp nut (C) which holds the upper knife driving arm (D). Access to clamp nut is through top cover. Draw driving arm to the left until upper knife driving lever (E) and connecting rod (F) drop, allowing removal of bearing cap (G). This is at bearing point (C, Fig. 25) on crankshaft. Observe same precautions when reassembling cap as described in paragraph 7.
9. Remove screw (L, Fig. 25) which holds inner right crankshaft bearing. This screw is reached through bottom of bed casting.
10. Loosen two screws (M) in fan collar; remove both halves of cooling fan.
11. Remove screw (N); take off pulley cap (P).
12. Loosen two screws (R); remove pulley (S).
13. Remove three screws (T); take off bearing retaining plate (U); also, spacer collars (V) and (W) may be removed at this time.
14. Crankshaft may now be removed.
15. If necessary to replace ball bearing (Y), it can be pressed off shaft on an arbor press. In replacing the bearing it must be pressed on carefully until it seats against ground thrust washer (X).
16. Carefully observing reverse of the foregoing operations should simplify reassembly of crankshaft. Checking exploded view drawings for location of various parts and constant testing for binds during reassembly will also prove helpful.
17. Before reassembling, thoroughly clean and dry the top and bottom covers and gaskets. Before reassembling bottom cover make sure that spring pressed oil wick which lubricates left crankshaft bearing is inserted in hole in casting and that it contacts shaft. The wick stands vertically on its spring against bottom cover. Coat the oil drain plug with a sealing compound before reassembling to prevent oil leakage. No. 1 Crane Lead Seal is recommended.

ORDERING REPAIR PARTS

ILLUSTRATIONS

This catalog has been arranged to simplify ordering repair parts. Exploded views of various sections of the mechanism are shown so that the parts may be seen in their actual position in the machine. On the page opposite the illustration will be found a listing of the parts with their part numbers, description and the number of pieces required in the particular view being shown.

Numbers in the first column are reference numbers only, and merely indicate the position of that part in the illustration. Reference numbers should never be used in ordering parts. Always use the part number listed in the second column.

Component parts of sub-assemblies which can be furnished for repairs are indicated by indenting their descriptions under the description of the main sub-assembly. Example:

37	29477 JU	Crankshaft and Needle Driving Crank Assembly, for Styles 39600 CA and CB, all gauges -----	1
	29477 JV	Crankshaft and Needle Driving Crank Assembly, for Styles 39600 CP, CQ, CR and CS, all gauges -----	1
38	51-228 Blk.	Vent Plug -----	1
39	WO-3	Wool Yarn, for crankshaft -----	as required
40	258	Nut -----	1
41	40-46	Washer -----	1
42	CO67 E	Cork Plug -----	1
43	39541 A	Feed Drive Eccentric Key -----	1
44	39516-625	Needle Bearing, .0625 inch diameter -----	28
	39516-626	Needle Bearing, .0626 inch diameter -----	28
	39516-627	Needle Bearing, .0627 inch diameter -----	28
45	29477 JN	Needle Driving Arm Crank and Connecting Rod Assembly -----	1
46	22596 G	Screw, for needle driving arm crank -----	1
47	22587 M	Screw, for needle driving arm connecting rod -----	2

It will be noted in the above example that the connecting rod and needle bearing are not listed. The reason is that replacement of these parts individually is not recommended, so the complete sub-assembly should be ordered.

Where parts for Styles 39600 CA, CB, CP, CQ, CR and CS are not the same, the difference will be shown in the illustrations or mentioned in the descriptions. When a part is used in all the machines covered by this catalog no machine style will be mentioned.

At the back of the book will be found a numerical index of all the parts shown in this book. This will facilitate locating the illustration and description when only the part number is known.

IDENTIFYING PARTS

When the construction permits, each part is stamped with its part number. Parts too small for a complete catalog stamping are identified by letter symbols which distinguish one part from another that is similar in appearance.

Part numbers represent the same part, regardless of catalog in which they appear.

IMPORTANT! ON ALL ORDERS, PLEASE INCLUDE PART NAME AND STYLE OF MACHINE FOR WHICH PART IS ORDERED.

USE GENUINE NEEDLES AND REPAIR PARTS

Success in the operation of these machines can be secured only with genuine UNION SPECIAL Needles and Repair Parts as furnished by the Union Special Corporation, its subsidiaries and authorized distributors. They are designed according to the most approved scientific principles, and are made with utmost precision. Maximum efficiency and durability are assured.

Genuine needle are packaged with labels marked *Union Special*[®]. Genuine repair parts are stamped with the Union Special trademark, US Emblem. Each trademark is your guarantee of the highest quality in materials and workmanship.

TERMS

Prices are strictly net cash and subject to change without notice. All shipments are forwarded f.o.b. shipping point. Parcel Post shipments are insured unless otherwise directed. A charge is made to cover postage and insurance.

TORQUE REQUIREMENTS

Torque (measured in inch-pounds) is a rotating force (in pounds) applied through a distance by a lever (in inches or feet). This is accomplished by a wrench, screw driver, etc. Many of these devices are available which when set at the proper amount of torque will tighten the part to the correct amount and no tighter.

All straps and eccentrics should be tightened to 19-21 inch-pounds, unless otherwise noted. All other nuts, bolts, screws, etc., should be tightened by hand as tightly as possible, unless otherwise noted.

The screws requiring a specific torque, will be indicated on the picture plates.

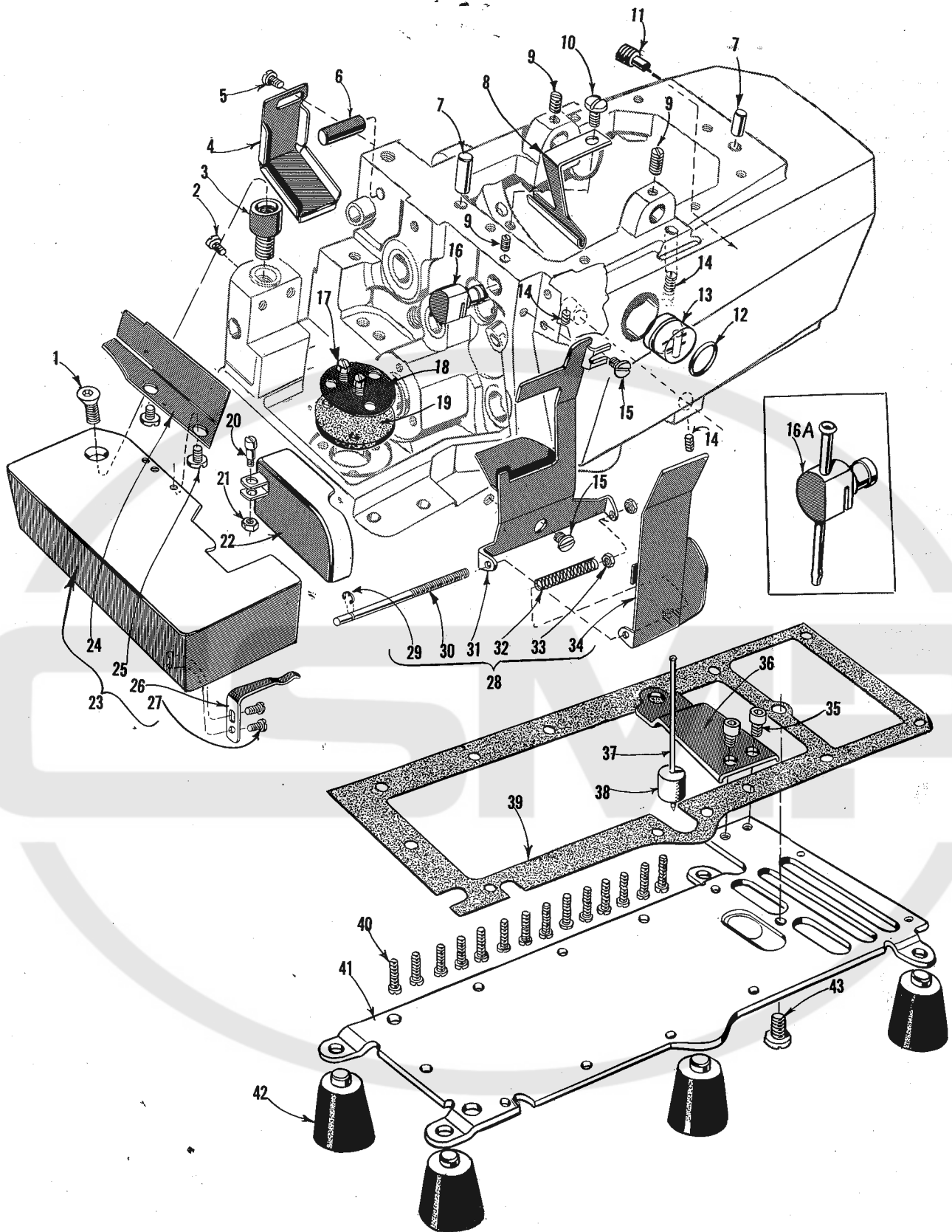

MAIN FRAME, MISCELLANEOUS COVERS AND PLATES

<u>Ref. No.</u>	<u>Part No.</u>	<u>Description</u>	<u>Amt. Req.</u>
1	22657 D-12	Screw, for cloth plate -----	1
2	22569	Screw, for cloth plate stud -----	1
3	39501 K	Cloth Plate Stud -----	1
4	39534 R	Feed Bar Oil Shield -----	1
5	90	Screw, for feed bar oil shield -----	1
6	667 H-16	Dowel Pin, for eyelet bracket -----	1
7	667 D-8	Dowel Pin, for top cover -----	2
8	39594 R	Oil Collector Plate -----	1
9	22565	Screw, for upper knife thrust block -----	1
-	22565	Screw, for upper looper rocker shaft -----	2
10	22569 D	Screw, for oil collector plate -----	1
11	22571 E	Magnetic Oil Drain Plug -----	1
12	660-243	Oil Gauge Seal Ring -----	1
13	39593 H	Oil Sight Gauge -----	1
14	22894 AD	Screw, for lower looper drive lever shaft -----	2
-	22894 AD	Screw, for lower looper bar driving lever shaft -----	2
15	22569 D	Screw, for chip guard -----	2
16	39673 C	Upper Knife Driving Arm Thrust Block, for Styles 39600 CA, CP and CR -----	1
16A	29477 HU	Upper Looper Thread Tube Assembly, for Style 39600 CB -----	1
-	29477 JZ	Upper Looper Thread Tube Assembly, for Styles 39600 CQ and CS -----	1
17	22824	Screw, for oil filter screen -----	2
18	39594 G	Oil Filter Screen -----	1
19	39594 H	Oil Strainer -----	1
20	86 X	Screw, for feed mechanism cover -----	1
21	41071 G	Nut, for feed mechanism cover screw -----	1
22	39582 DA	Feed Mechanism Cover -----	1
23	39501 DF	Cloth Plate, for semi or fully-submerged installation -	1
24	39578 F	Cloth Plate Fabric Guard -----	1
25	138	Screw, for cloth plate fabric guard -----	2
26	39532 A	Cloth Plate Latch Spring -----	1
27	90	Screw, for cloth plate latch spring -----	2
28	39678 AB	Chip Guard Assembly -----	1
29	660-210	Retaining Ring -----	1
30	39878 C	Hinge Pin -----	1
31	39678 U	Chip Guard Base -----	1
32	39158 U	Spring -----	1
33	43443 Q	Nut, for hinge pin -----	2
34	39678 AC	Chip Guard Cover -----	1
35	22653 D-4	Screw, for bottom cover and base plate extension ----	1
36	39582 F	Bottom Cover and Base Plate Extension -----	1
37	39593 D.	Oil Gauge Indicator -----	1
38	39593 C	Oil Gauge Float -----	1
39	39582 Y	Bottom Cover Gasket -----	1
40	22569	Screw, for bottom cover -----	14
41	39582 XD	Bottom Cover -----	1
42	39595	Mounting Isolator, rubber -----	4
43	22586 R	Screw, for bottom cover -----	1

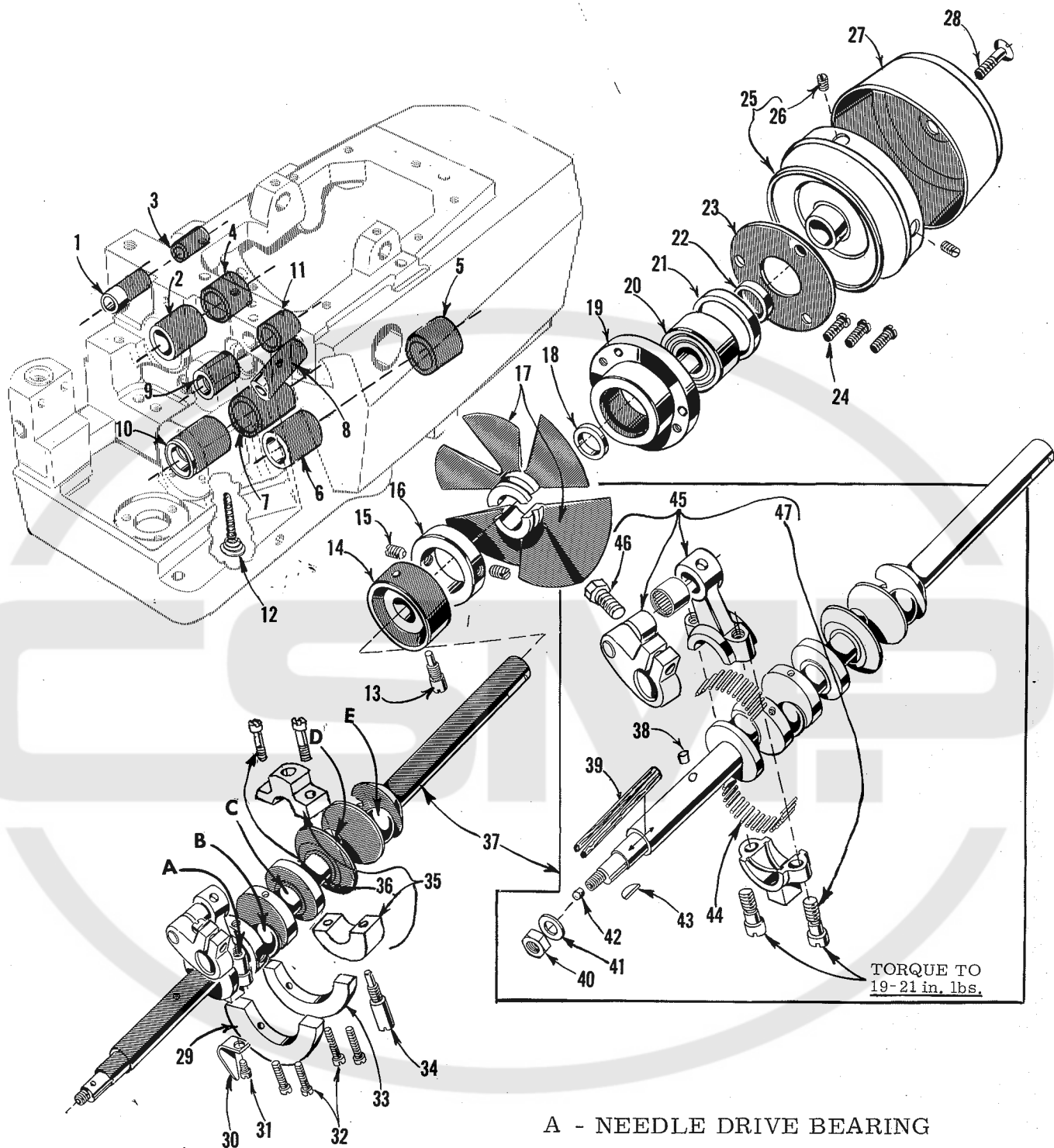

- A - NEEDLE DRIVE BEARING
- B - UPPER LOOPER DRIVE BEARING
- C - UPPER KNIFE DRIVE BEARING
- D - LOWER LOOPER DRIVE BEARING
- E - AUX. LOOPER DRIVE BEARING

CRANKSHAFT MECHANISM AND BUSHINGS

<u>Ref. No.</u>	<u>Part No.</u>	<u>Description</u>	<u>Amt. Req.</u>
1	39555 E	Foot Lifter Shaft Bushing, left -----	1
2	39573 K	Upper Knife Driving Arm Bushing, left -----	1
3	39555 N	Foot Lifter Shaft Bushing, right -----	1
4	39573 AA	Upper Knife Driving Arm Bushing, right -----	1
5	39644 C	401 Looper Drive Shaft Bushing, right -----	1
6	39644 S	401 Looper Drive Shaft Bushing, left -----	1
7	39590 T	Crankshaft Bushing, inner left -----	1
8	39544 L	Lower Looper Bar Bushing -----	1
9	39552 U	Needle Driving Arm Crank Bushing, left -----	1
10	39590	Crankshaft Bushing, left -----	1
11	39552 P	Needle Driving Arm Crank Bushing, right -----	1
12	666-94	Oil Wick and Spring -----	1
13	39690 A	Stud, for crankshaft bearing -----	1
14	39690	Crankshaft Bearing, inner right -----	1
15	22894 D	Screw, for fan collar -----	2
16	39591 H	Chamber Cooling Fan Collar -----	1
17	39591 L	Chamber Cooling Fan -----	1
18	39590 J	Thrust Washer -----	1
19	39590 G	Crankshaft Ball Bearing Housing -----	1
20	660-268	Crankshaft Ball Bearing -----	1
21	39590 R	Ball Bearing Stop Collar -----	1
22	39590 S	Spacer Collar -----	1
23	39590 H	Crankshaft Ball Bearing Retaining Plate -----	1
24	22569 B	Screw, for ball bearing housing -----	3
25	39521 C	Pulley -----	1
26	95	Screw, for pulley -----	2
27	39521 D	Pulley Cap -----	1
28	22769 B	Screw, for pulley cap -----	1
29	39591 K	Crankshaft Counterweight, left -----	1
30	39594 N	Oil Splasher -----	1
31	87 U	Screw, for oil splasher -----	1
32	22747 B	Screw, for counterweights -----	4
33	39691	Crankshaft Counterweight, right -----	1
34	39590 N	Stud, for split bearing -----	1
35	39690 B	Crankshaft Split Bearing -----	1
36	97 A	Screw, for split bearing -----	2
37	29477 JU	Crankshaft and Needle Driving Crank Assembly, for Styles 39600 CA and CB, all gauges -----	1
	29477 JV	Crankshaft and Needle Driving Crank Assembly, for Styles 39600 CP, CQ, CR and CS, all gauges -----	1
38	51-228 Blk.	Vent Plug -----	1
39	WO-3	Wool Yarn, for crankshaft -----as required	
40	258	Nut -----	1
41	40-46	Washer -----	1
42	CO67 E	Cork Plug -----	1
43	39541 A	Feed Drive Eccentric Key -----	1
44	39516-625	Needle Bearing, .0625 inch diameter -----	28
	39516-626	Needle Bearing, .0626 inch diameter -----	28
	39516-627	Needle Bearing, .0627 inch diameter -----	28
*45	29477 JN	Needle Driving Arm Crank and Connecting Rod Assembly -----	1
46	22596 G	Screw, for needle driving arm crank -----	1
47	22587 M	Screw, for needle driving arm connecting rod -----	2

* NOTE: No. 29477 JN has been replaced by No. 29480 LS.

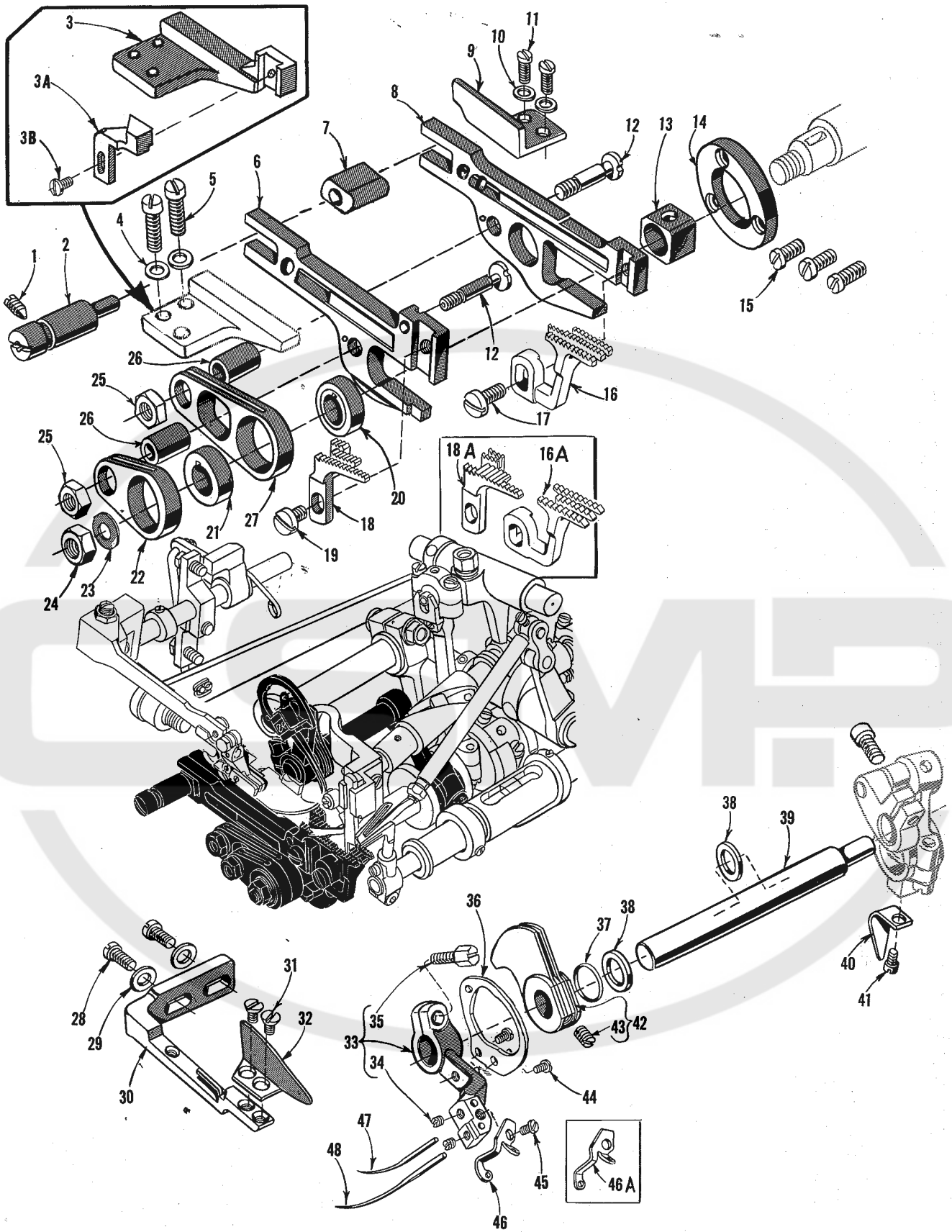

NEEDLE DRIVE, FEED MECHANISM AND FEED DOGS

<u>Ref. No.</u>	<u>Part No.</u>	<u>Description</u>	<u>Amt. Req.</u>
1	22565 F	Screw, for feed adjusting pin -----	1
2	39535 C	Feed Adjusting Pin -----	1
3	39635	Main Feed Bar Guide, left -----	1
3A	39680	Throat Plate Support Stop -----	1
3B	93 A	Screw, for throat plate support stop-----	1
4	53634 C	Washer, for feed bar guide screw-----	2
5	22569 B	Screw, for main feed bar guide -----	2
6	39534	Main Feed Bar-----	1
7	39535 J	Feed Bar Guide Block -----	1
8	39534 GA	Differential Feed Bar-----	1
9	39535 D	Differential Feed Bar Guide, right -----	1
10	53634 C	Washer, for feed bar guide screw-----	2
11	22569 B	Screw, for feed bar guide -----	2
12	39536 B	Feed Bar Driving Stud -----	2
13	39538	Feed Lift Block -----	1
14	39534 H	Differential Feed Bar Thrust Washer-----	1
15	22569 G	Screw, for thrust washer -----	3
16	39626 D	Differential Feed Dog, 16 teeth per inch, marked "BR"; for No. 5 1/8 gauge, all Styles -----	1
	*39626 C	Differential Feed Dog, 14 teeth per inch, marked "BP"; for No. 5 1/8 gauge, all Styles -----	1
	*39626 E	Differential Feed Dog, 22 teeth per inch, marked "BS"; for No. 5 1/8 gauge, all Styles -----	1
16A	39626 F	Differential Feed Dog, 14 teeth per inch, marked "BT"; for No. 12 3/16 gauge, Styles 39600 CP, CQ, CR and CS -----	1
	39626 G	Differential Feed Dog, 16 teeth per inch, marked "BU"; for No. 12 3/16 gauge, Styles 39600 CA and CB -----	1
	*39626 H	Differential Feed Dog, 22 teeth per inch, marked "BV"; for No. 12 3/16 gauge, all Styles -----	1
17	93	Screw, for differential feed dog-----	1
18	39605 F-5 1/8	Main Feed Dog, 16 teeth per inch, marked "DG"; for No. 5 1/8 gauge, all Styles (throat plate No. 39624 F-5 1/8) -----	1
	*39605 H-5 1/8	Main Feed Dog, 22 teeth per inch, marked "DZ-5 1/8"; for No. 5 1/8 gauge, all Styles (throat plate No. 39624 F-5 1/8) -----	1
	*39605 G-5 1/8	Main Feed Dog, 14 teeth per inch, marked "DY-5 1/8"; for No. 5 1/8 gauge, all Styles (throat plate No. 39624 F-5 1/8) -----	1
18A	39605 G-12 3/16	Main Feed Dog, 16 teeth per inch, marked "DY-12 3/16"; for No. 12-3/16 gauge, Styles 39600 CA and CB (throat plate No. 39624 F-12 3/16)-----	1
	39605 F-12 3/16	Main Feed Dog, 14 teeth per inch, marked "DH"; for No. 12 3/16 gauge, Styles 39600 CP, CQ, CR and CS (throat plate No. 39624 F-12 3/16) ----	1
	*39605 H-12 3/16	Main Feed Dog, 22 teeth per inch, marked "DZ-12 3/16"; for No. 12 3/16 gauge, all Styles (throat plate No. 39624 F-12 3/16)-----	1
19 to 48		See following page	

* Available as extra send and charge item.

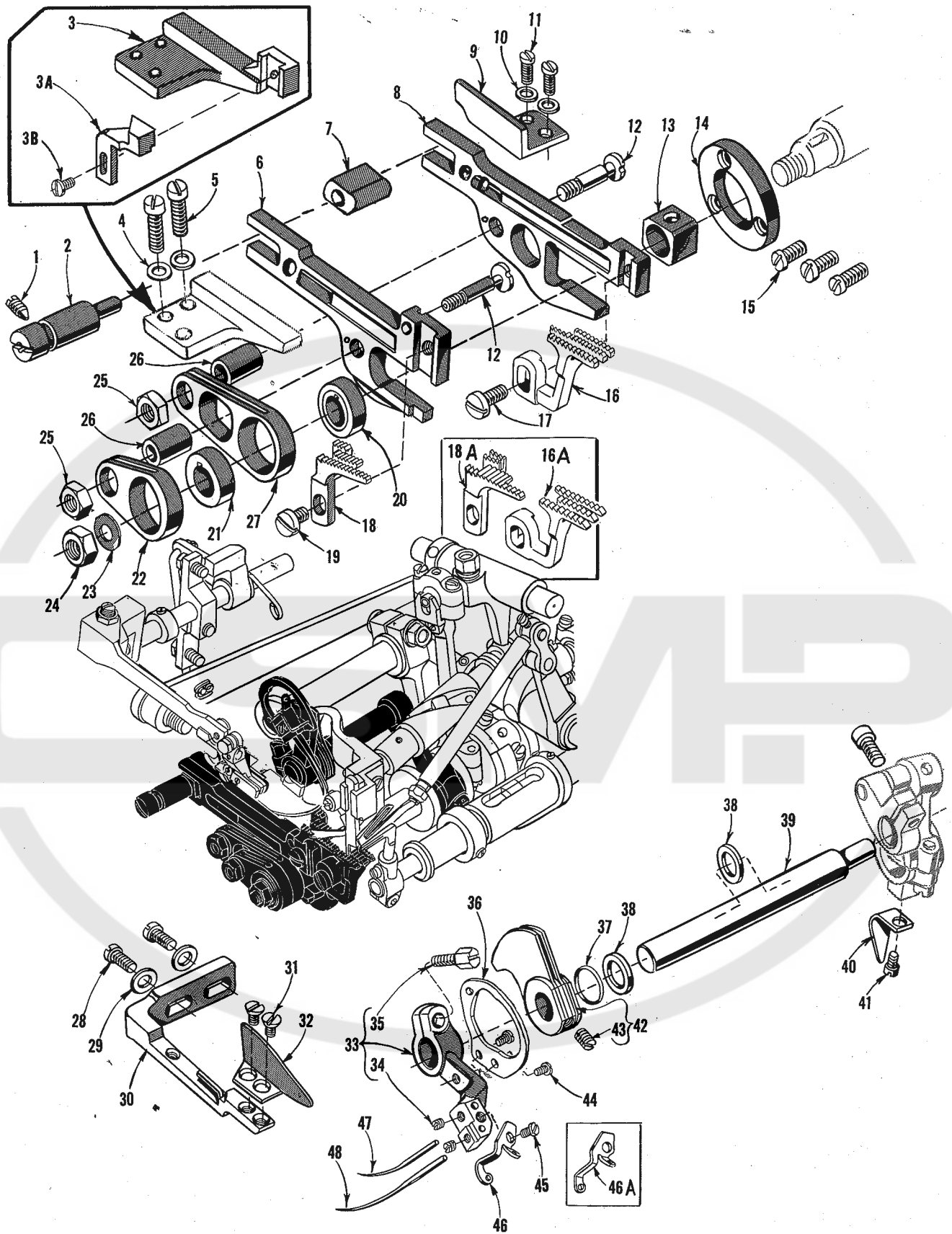

NEEDLE DRIVE, FEED MECHANISM AND FEED DOGS

<u>Ref. No.</u>	<u>Part No.</u>	<u>Description</u>	<u>Amt. Req.</u>
1 to 18A		See preceding page	
19	93 A	Screw, for main feed dog -----	1
20	39540 B-11	Differential Feed Driving Eccentric, for Styles 39600 CA and CB -----	1
	39540 B-10	Differential Feed Driving Eccentric, for Styles 39600 CP, CQ, CR and CS -----	1
21	39540 B-10	Main Feed Driving Eccentric, for Styles 39600 CA and CB -----	1
	39540 B-9	Main Feed Driving Eccentric, for Styles 39600 CP, CQ, CR and CS -----	1
22	39536 AF	Main Feed Bar Driving Connection -----	1
23	40-46	Washer, for feed driving eccentric -----	1
24	258	Nut, for feed driving eccentric -----	1
25	39536 E	Nut, for feed bar driving stud -----	2
26	39536 C	Feed Bar Driving Connection Bushing -----	2
27	39536 AE	Differential Feed Bar Driving Connection -----	1
28	22569 B	Screw, for fabric guard mounting bracket -----	2
29	8372 A	Washer, for fabric guard mounting bracket -----	2
30	39578 P	Fabric Guard Mounting Bracket -----	1
31	87	Screw, for fabric guard -----	2
32	39578 M	Fabric Guard -----	1
33	39652-5	Needle Driving Arm, marked "E-5"; for No. 5 1/8 gauge, all Styles -----	1
	39652-12	Needle Driving Arm, marked "E-12"; for No. 12 3/16 gauge, all Styles -----	1
34	28 B	Screw, for needles -----	2
35	22519 H	Screw, for needle driving arm -----	1
36	39663 L	Needle Thread Cam Pull-off -----	1
37	660-207	"O" Ring, for take-up cam -----	1
38	39552 C	Needle Driving Arm Crank Thrust Washer -----	2
39	39552 R	Needle Lever Drive Shaft -----	1
40	39594 N	Oil Splasher -----	1
41	87 U	Screw, for oil splasher -----	1
42	39668 J	Looper Thread Take-up Cam -----	1
43	531	Screw, for looper thread take-up cam -----	1
44	22768	Screw, for needle thread cam pull-off -----	1
45	22784 E	Screw, for needle driving arm thread eyelet -----	1
46	39652 B	Needle Driving Arm Thread Eyelet, for No. 5 1/8 gauge, all Styles -----	1
46A	39652 C	Needle Driving Arm Thread Eyelet, for No. 12 3/16 gauge, all Styles -----	1
47	154 GAS	Needle, for 503 or 504 stitch -----	1
48	158 GJS	Needle, for 401 stitch -----	1

* Available as extra send and charge item.

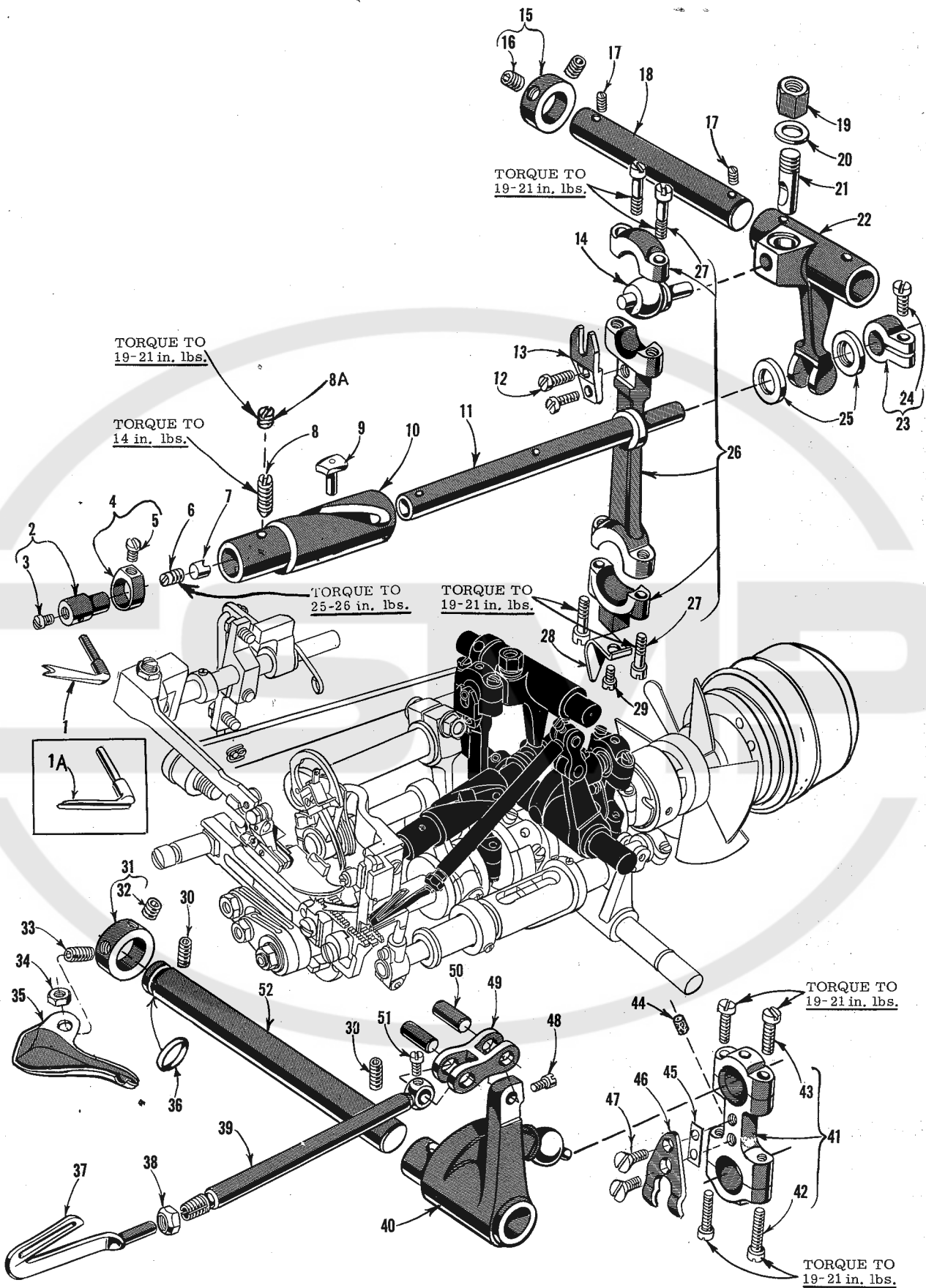

UPPER LOOPER, SPREADER AND LOWER LOOPER DRIVING PARTS

<u>Ref. No.</u>	<u>Part No.</u>	<u>Description</u>	<u>Amt. Req.</u>
1	39560 A	Spreader, marked "E", for Styles 39600 CA, CP and CR	1
1A	39508 A	Upper Looper, marked "CC", for Styles 39600 CB, CQ and CS	1
2	39543	Spreader or Upper Looper Holder, marked "J"	1
3	22564 G	Screw, for spreader or upper looper	1
4	39543 A	Spreader Holder Collar	1
5	22 KH	Screw, for spreader holder collar	1
6	22503 F	Screw, for cam follower locking clamp	1
7	39543 E	Cam Follower Locking Clamp	1
8	22565 H	Screw, for bushing and cam guide	1
8A	1025 L	Lock Screw, for screw No. 22565 H	1
9	39543 T	Cam Follower	1
10	39543 S	Spreader or Upper Looper Drive Shaft Bushing and Cam Guide	1
11	39543 K	Spreader or Upper Looper Drive Shaft	1
12	97	Screw, for guide fork	2
13	39544 J	Guide Fork	1
14	39543 V	Ball Stud	1
15	482 C	Spreader Drive Lever Shaft Collar	1
16	22894 C	Screw, for collar	2
17	22565	Screw, for spreader drive lever shaft	2
18	39543 X	Spreader or Upper Looper Drive Lever Shaft	1
19	1280	Nut, for locking stud	1
20	39543 R	Washer, for locking stud	1
21	43143 N	Locking Stud, for spreader drive lever shaft	1
22	39543 H	Spreader or Upper Looper Drive Lever	1
23	39543 M	Clamp Collar	1
24	22562 A	Screw, for clamp collar	1
25	39543 P	Thrust Washer, for spreader drive shaft	2
26	39543 U	Spreader or Upper Looper Drive Lever Connecting Rod	1
27	22729 D	Screw, for connecting rod assembly	4
28	39594 N	Oil Splasher	1
29	87 U	Screw, for oil splasher	1
30	22894 AD	Screw, for lower looper bar driving lever shaft	2
31	482 C	Lower Looper Shaft Collar	1
32	22894 C	Screw, for collar	1
33	22894 J	Screw, for knife drive oil drip plate	1
34	12982	Nut, for knife drive oil drip plate screw	1
35	39694	Knife Drive Connecting Rod Oil Drip Plate	1
36	660-206	"O" Ring, for lower looper bar driving lever shaft	1
37	39508 B	Lower Looper	1
38	39151	Nut, for lower looper bar	1
39	39544	Lower Looper Bar	1
40	39544 U	Lower Looper Bar Driving Lever	1
41	39644 F	Lower Looper Drive Lever Connecting Rod	1
42	22729 E	Screw, for connecting rod	2
43	22729 D	Screw, for connecting rod	2
44	666-255	Felt Plug, for No. 39543 U and 39644 F	2
45	39644 R-2	Shim, for ball joint guide fork, .002 inch thick	as required
	39644 R-5	Shim, for ball joint guide fork, .005 inch thick	as required
46	39644 X	Ball Joint Guide Fork	1
47	538	Screw, for ball joint guide fork	2
48	77	Screw, for connecting link pin	1
49	39544 B	Lower Looper Bar Connecting Link	1
50	39544 D	Lower Looper Bar Connecting Link	2
51	77	Screw, for connecting link pin	1
52	39544 V	Lower Looper Bar Driving Lever Shaft	1

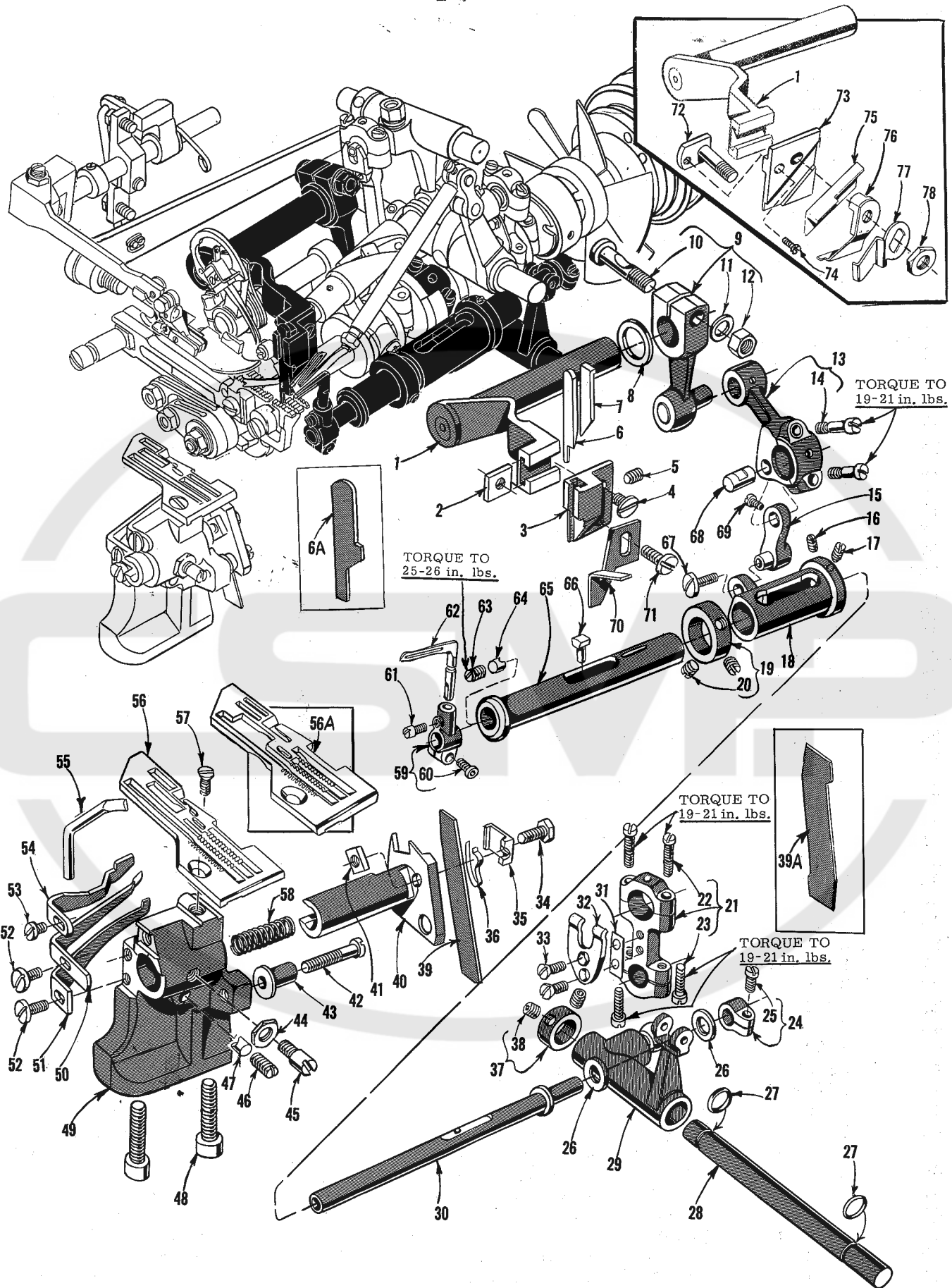

THROAT PLATES, NEEDLE GUARDS, 401 STITCH LOOPER PARTS,
UPPER AND LOWER KNIFE MECHANISM

Ref. No.	Part No.	Description	Amt. Req.
1	39673 A	Upper Knife Driving Arm -----	1
2	39571 A	Upper Knife Clamp Nut, for Styles 39600 CA, CB, CP and CQ -----	1
3	39572 B	Upper Knife Holder, for Styles 39600 CA, CB, CP and CQ -----	1
4	22829	Screw, for upper knife holder, for Styles 39600 CA, CB, CP and CQ -----	1
5	22650 CB-4	Set Screw, for upper knife, for Styles 39600 CA, CB, CP and CQ -----	1
6	39270 D	Upper Knife, narrow, for Styles 39600 CA and CB ----	1
6A	39270 E	Upper Knife, wide, for Styles 39600 CP and CQ -----	1
7	39571 E	Upper Knife Clamp, for Styles 39600 CA, CB, CP and CQ -----	1
8	39573 A	Upper Knife Driving Arm Washer -----	1
9	39573 E	Upper Knife Driving Lever -----	1
10	55235 D	Locking Stud, for driving lever -----	1
11	6042 A	Washer, for driving lever -----	1
12	55235 E	Nut, for driving lever -----	1
13	39673	Upper Knife Driving Lever Connecting Rod -----	1
14	22587 E	Screw, for connecting rod -----	2
15	39644 M	Looper Avoid Link -----	1
16	22565 C	Set Screw, for bushing and cam guide -----	1
17	22565 L	Spot Screw, for bushing and cam guide -----	1
18	39644 K	Bushing and Cam Guide -----	1
19	39644 P	Thrust Collar -----	1
20	98	Screw, for thrust collar -----	2
21	39644 U	Looper Drive Lever Auxiliary Connecting Rod -----	1
22	22729 E	Screw, for connecting rod -----	2
23	22729 D	Screw, for connecting rod -----	2
24	39543 M	Clamp Collar -----	1
25	22562 A	Screw, for clamp collar -----	1
26	39543 P	Thrust Washer, for lower looper bar -----	2
27	660-206	"O" Ring, for lower looper drive lever shaft -----	2
28	39644 N	Lower Looper Drive Lever Shaft -----	1
29	39644	Lower Looper Drive Lever -----	1
*30	39644 A	Lower Looper Bar (401 stitch) -----	1
31	39644 R-2	Shim, for ball joint guide fork, .002 inch thick -----	as required
-	39644 R-5	Shim, for ball joint guide fork, .005 inch thick -----	as required
32	39644 X	Ball Joint Guide Fork -----	1
33	538	Screw, for ball joint guide fork -----	2
34	22588 J	Screw, for lower knife clamp -----	1
35	39550 Z	Lower Knife Clamp -----	1
36	39550 M	Lower Knife Clamp Spring -----	1
37	482 C	Lower Looper Drive Lever Shaft Collar -----	1
38	22894 C	Screw, for collar -----	2
39	39549	Lower Knife, narrow, for Styles 39600 CA and CB ----	1
39A	39549 J	Lower Knife, wide, for Styles 39600 CP, CQ, CR and CS -----	1

40 to 78

See following page

* Includes Det. 63 and 64, part Nos. 22503 F and 39543 E respectively.

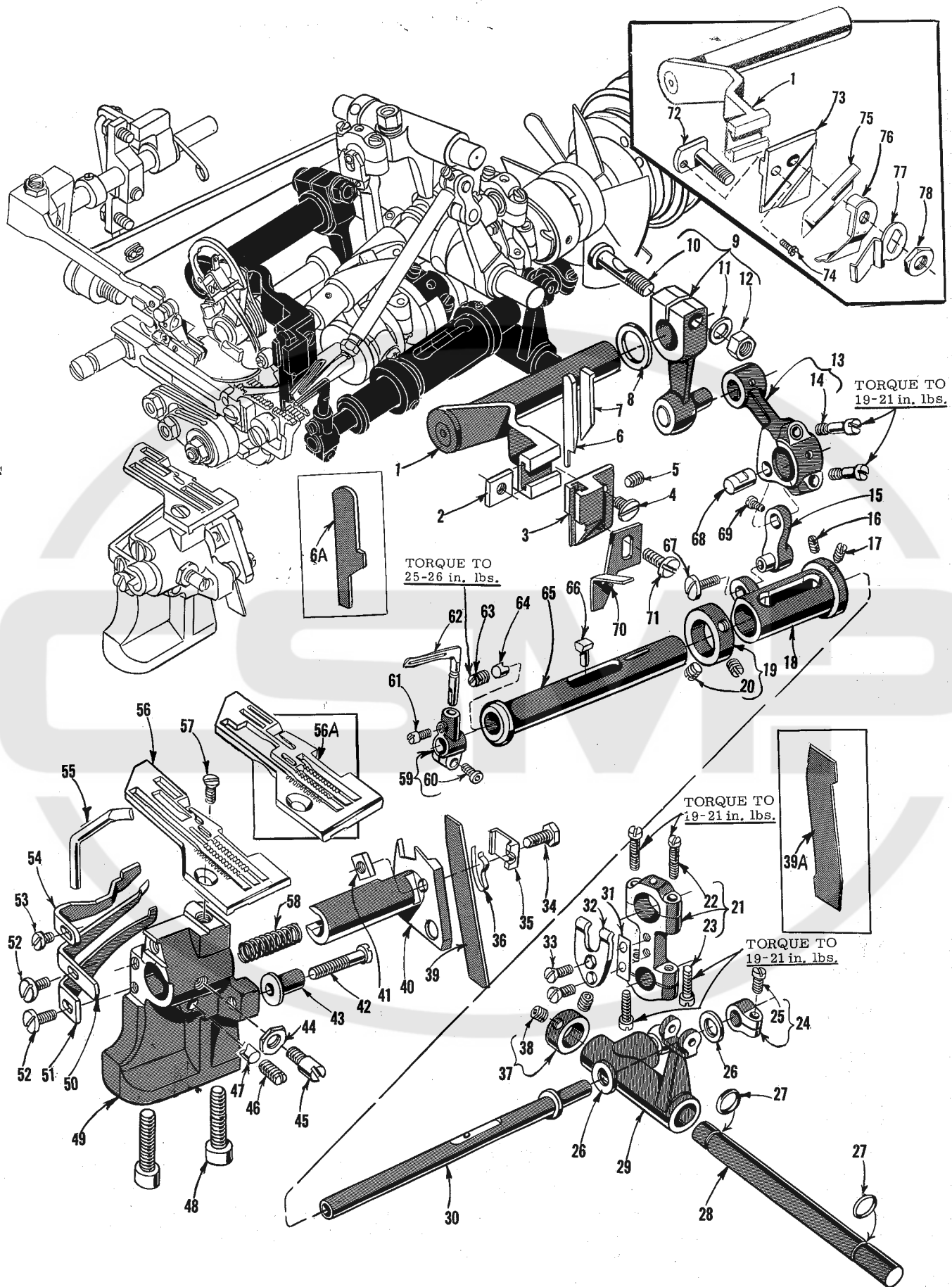

THROAT PLATES, NEEDLE GUARDS, 401 STITCH LOOPER PARTS,
UPPER AND LOWER KNIFE MECHANISM

Ref. No.	Part No.	Description	Amt. Req.
1 to 39A		See preceding page	
40	39650	Lower Knife Holder -----	1
41	39650 A	Lower Knife Clamp Screw Nut -----	1
42	22729 B	Screw, for lower knife holder locating stud -----	1
43	39550 C	Lower Knife Holder Locating Stud -----	1
44	14077	Nut, for locking screw -----	1
45	22892 B	Locking Screw, for lower knife holder -----	1
46	88 F	Screw, for needle guard -----	1
47	39543 E	Needle Guard Locking Clamp -----	1
48	22653 B-12	Screw, for throat plate support bracket -----	2
49	39580 AC	Throat Plate and Lower Knife Support Bracket ----	1
50	39525 A	Needle Guard, rear, for 503 or 504 stitch needle -----	1
51	39625 B	Needle Guard, front, for 503 or 504 stitch needle -----	1
52	22585 A	Screw, for 503 or 504 stitch needle guards -----	2
53	90	Screw, for 401 stitch front needle guard -----	1
54	39825 C	Needle Guard, front, for 401 stitch needle -----	1
55	39625	Needle Guard, rear, for 401 stitch needle -----	1
56	39624 F-5-1/8	Throat Plate, marked "CB", for No. 5-1/8 gauge, all Styles -----	1
56A	39624 F-12-3/16	Throat Plate, marked "CA", for No. 12-3/16 gauge, all Styles -----	1
57	22524	Screw, for throat plate -----	1
58	39550 E	Knife Holder Spring -----	1
59	39644 E	Looper Holder, for 401 stitch looper -----	1
60	22653 J-4	Screw, for looper holder -----	1
61	22564 D	Screw, for 401 stitch looper -----	1
62	39608 C	Looper, marked "CR", for 401 stitch -----	1
63	22503 F	Screw, for cam follower locking clamp -----	1
64	39543 E	Cam Follower Locking Clamp -----	1
65	39644 W	Lower Looper Bar Sleeve -----	1
66	39644 L	Cam Follower -----	1
67	22775	Screw, for looper avoid link -----	1
68	41336 C	Looper Avoid Link Pin -----	1
69	22781	Screw, for looper avoid link pin -----	1
70	39678 P	Chip Deflector, for Styles 39600 CA and CB -----	1
71	187 A	Screw, for chip deflector -----	1
72	39571 C	Upper Knife Clamp Stud, for Styles 39600 CR and CS -----	1
73	39572 A	Upper Knife Holder Block, for Styles 39600 CR and CS -----	1
74	22738	Screw, for upper knife clamp stud -----	1
75	39570 K	Upper Knife, for Styles 39600 CR and CS -----	1
76	39571 F	Upper Knife Clamp, for Styles 39600 CR and CS ---	1
77	39571 B	Upper Knife Chain Guard, for Styles 39600 CR and CS -----	1
78	14077	Nut, for upper knife clamp stud -----	1

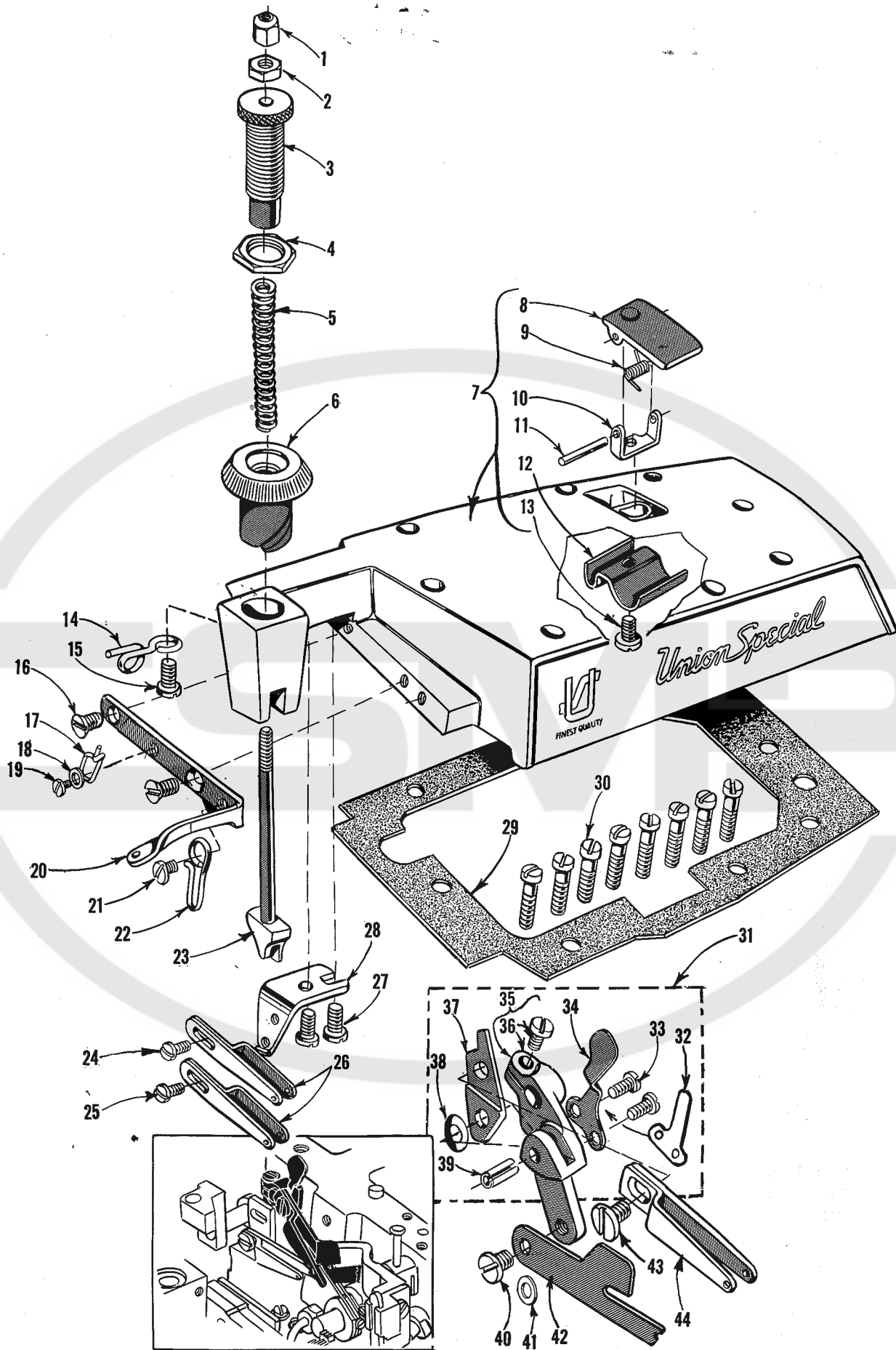

TOP COVER, EYELETS AND PRESSER SPRING PARTS

<u>Ref. No.</u>	<u>Part No.</u>	<u>Description</u>	<u>Amt. Req.</u>
1	39557 B	Presser Spring Plunger Cap Nut -----	1
2	39557 E	Presser Spring Plunger Lock Nut -----	1
3	39557 C	Presser Spring Plunger Adjusting Screw -----	1
4	39557 F	Lock Nut, for plunger adjusting screw -----	1
5	39557	Presser Spring -----	1
6	39556 A	Presser Foot Release Bushing -----	1
7	39582 AJ	Top Cover -----	1
8	39582 AF	Oil Filler Cover -----	1
9	39582 V	Spring, for oil filler cover -----	1
10	39582 AG	Hinge Bracket -----	1
11	51-103 Blk.	Hinge Pin -----	1
12	39582 W	Oil Guard -----	1
13	22562 A	Screw, for hinge bracket -----	1
14	52958	Needle Thread Eyelet, for Styles 39600 CB, CQ and CS -----	1
15	22849 A	Screw, for needle thread eyelet -----	1
16	22757 E	Screw, for top cover needle thread eyelet -----	2
17	51758	Needle Thread Eyelet -----	1
18	53678 N	Washer, for needle thread eyelet screw -----	1
19	90	Screw, for needle thread eyelet -----	1
20	39663 J	Top Cover Needle Thread Eyelet -----	1
21	22825	Screw, for looper thread eyelet -----	1
22	39668 D	Looper Thread Eyelet -----	1
23	39557 A	Presser Spring Plunger -----	1
24	87 U	Screw, for needle thread pull-off eyelet, for Styles 39600 CB, CQ and CS -----	1
25	87 U	Screw, for needle thread pull-off eyelet, for all Styles -----	1
26	39663 H	Needle Thread Pull-off Eyelet, for Styles 39600 CA, CP and CR -----	1
	39663 H	Needle Thread Pull-off Eyelet, for Styles 39600 CB, CQ and CS -----	2
27	22569 C	Screw, for top cover eyelet bracket -----	2
28	39663 K	Top Cover Eyelet Bracket -----	1
29	39582 AE	Top Cover Gasket -----	1
30	22541	Screw, for top cover -----	8
31	39668 C	Eyelet Bracket Assembly -----	1
32	39668 K	Latch Spring Stop Plate -----	1
33	605	Screw, for latch spring -----	2
34	39668 G	Latch Spring -----	1
35	39668 L	Eyelet Bracket -----	1
36	22570 A	Screw, for eyelet bracket -----	1
37	39668 F	Arm -----	1
38	39668 H	Spring Washer, for arm -----	1
39	660-219 N	Roll Pin, for arm -----	1
40	22570 B	Screw, for cast-off blade -----	1
41	53634 C	Washer, for cast-off blade screw -----	1
42	39668 BA	Cast-off Blade -----	1
43	22829	Screw, for take-up eyelet -----	1
44	39668 E	Take-up Eyelet -----	1

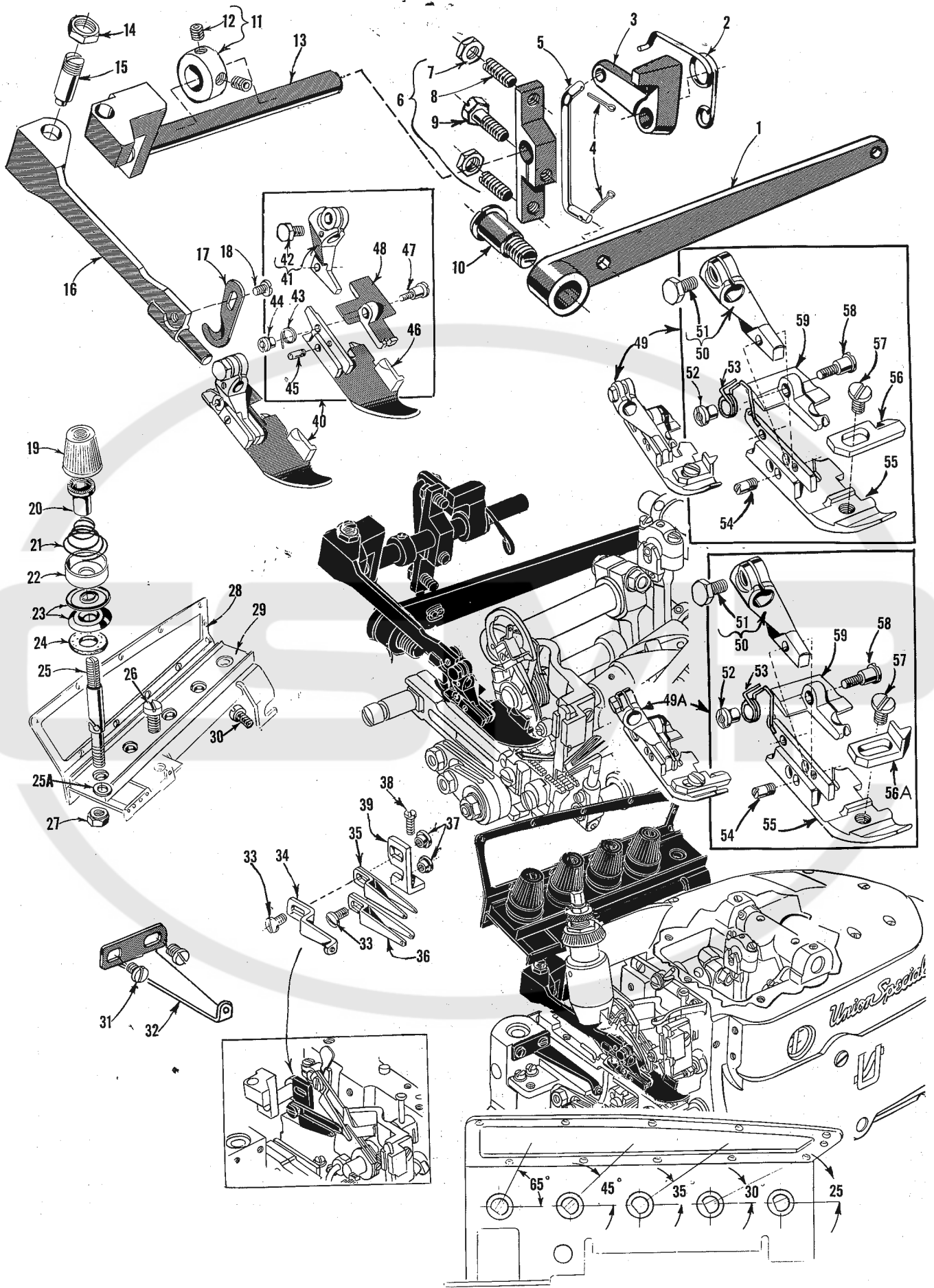

PRESSER FEET, FOOT LIFTER PARTS, THREAD TENSION AND MISCELLANEOUS EYELETS

<u>Ref. No.</u>	<u>Part No.</u>	<u>Description</u>	<u>Amt. Req.</u>
1	39855	Foot Lifter Lever -----	1
2	39555 B	Foot Lifter Lever Spring -----	1
3	39555 D	Foot Lifter Intermediate Lever -----	1
4	660-142	Cotter Pin, for connecting link -----	2
5	39555 F	Foot Lifter Lever Connecting Link -----	1
6	39555 C	Foot Lifter Lever Arm -----	1
7	12538	Lock Nut, for lever arm -----	2
8	22597 E	Screw, for lever arm -----	2
9	627	Screw, for lever arm -----	1
10	22566 B	Screw, for foot lifter lever -----	1
11	12865	Thrust Collar, for foot lifter lever shaft -----	1
12	88	Screw, for thrust collar -----	2
13	39655	Foot Lifter Lever Shaft -----	1
14	258 A	Nut, for presser arm screw -----	1
15	22791 H	Screw, for presser arm -----	1
16	39656 B	Presser Arm -----	1
17	39656 A	Chain Cutting Knife, marked "AC" -----	1
18	605	Screw, for chain cutting knife -----	1
19	39592 Y	Upper Looper Tension Nut, black, for Styles 39600 CB, CQ and CS -----	1
	39592 Z	Lower Looper Tension Nut, yellow -----	1
	39592 AA	Overedge Needle Tension Nut, green -----	1
	39592 AB	401 Stitch Looper Tension Nut, blue -----	1
	39592 AC	401 Stitch Needle Tension Nut, red -----	1
20	39592 AK	Tension Spring Ferrule -----	4 or 5
21	39592 AR-2	Tension Spring, for 401 stitch looper, all Styles except 39600 CA-5-1/8 -----	1
-	39592 AR-4	Tension Spring, for 401 stitch looper, for Style 39600 CA-5-1/8 -----	1
	39592 AR-4	Tension Spring, for needles and 503 stitch looper on Styles 39600 CA, CP and CR, except Style 39600 CA-5-1/8 -----	3
-	39592 AR-5	Tension Spring, for needles and 503 looper on Style 39600 CA-5-1/8 -----	3
	39592 AR-4	Tension Spring, for needles and 504 stitch loopers on Styles 39600 CB, CQ and CS -----	4
22	39592 AJ	Spring Shield -----	4 or 5
23	39592 AD	Thread Tension Disc -----	8 or 10
24	39592 AF	Tension Disc Felt -----	4 or 5
25	39592 AL	Thread Tension Post -----	4 or 5
25A	8372 A	Washer, for thread tension post -----	4 or 5
26	22806 A	Screw, for tension post mounting bracket -----	1
27	39592 AH	Nut, for thread tension post -----	4 or 5
28	39592 AG-5	Tension Post Mounting Bracket -----	1
29	39592 AN	Tension Post Bar -----	1
30	22847 B	Screw, for tension post mounting bracket -----	1
31	73 X	Screw, for frame thread guide -----	2
32	39668 W	Frame Thread Guide, for lower looper thread, for all Styles -----	1
33 to 59		See following page	

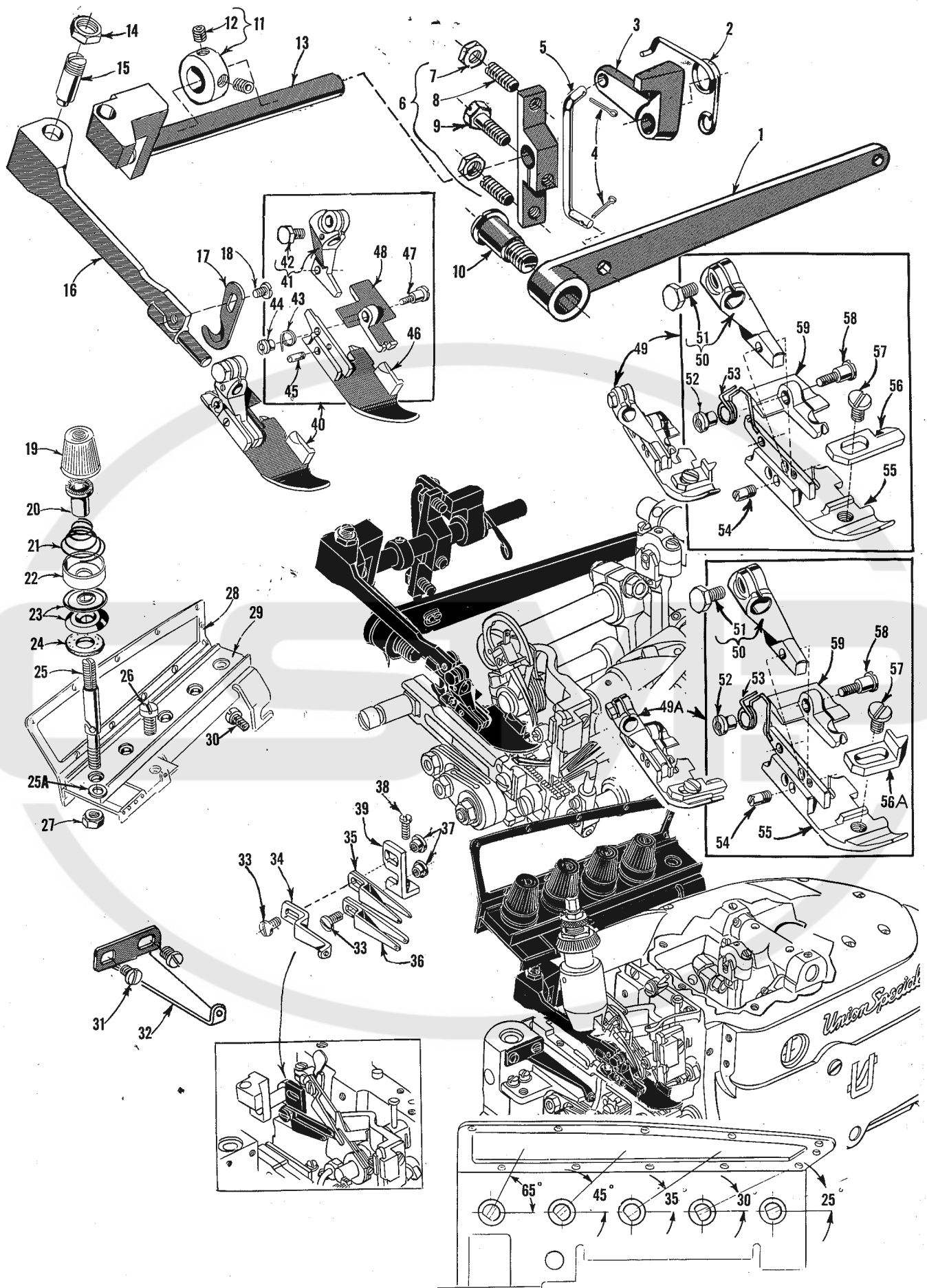

PRESSER FEET, FOOT LIFTER PARTS, THREAD TENSION AND
MISCELLANEOUS EYELETS

<u>Ref. No.</u>	<u>Part No.</u>	<u>Description</u>	<u>Amt. Req.</u>
1 to 32		See preceding page	
33	376 A	Screw, for looper thread eyelet, Styles 39600 CA, CP and CR----	1
	376 A	Screw, for looper thread eyelet, Styles 39600 CB, CQ and CS ----	2
34	39568 E	Auxiliary Upper Looper Thread Eyelet, for Styles 39600 CB, CQ and CS -----	1
35	39568 L	Upper Looper Thread Eyelet, for Styles 39600 CB, CQ and CS ---	1
36	39568 B	Lower Looper Thread Eyelet, for No. 5-1/8 gauge all Styles and No. 12-3/16 gauge Styles 39600 CB, CQ and CS -----	1
	39568 L	Lower Looper Thread Eyelet, for No. 12-3/16 gauge Styles 39600 CA, CP and CR -----	1
37	43139 A	Nut, for looper thread eyelet screw, for Styles 39600 CA, CP and CR-----	1
	43139 A	Nut, for looper thread eyelet screw, for Styles 39600 CB, CQ and CS -	2
38	22569 B	Screw, for eyelet mounting bracket-----	1
39	39568 D	Looper Thread Eyelet Mounting Bracket -----	1
40	39620 C-5-1/8	Presser Foot, for No. 5-1/8 gauge, Styles 39600 CA and CB----	1
-	39620 C-12-3/16	Presser Foot, for No. 12-3/16 gauge, Styles 39600 CA and CB---	1
41	39630 G	Presser Foot Shank, marked "D", for No. 5-1/8 gauge-----	1
-	39630 J	Presser Foot Shank, marked "E", for No. 12-3/16 gauge---	1
42	22781	Clamp Screw -----	1
43	39630 AC	Spring -----	1
44	39630 L	Lock Nut -----	1
45	22799 U	Hinge Screw, for presser foot bottom -----	1
46	39630 F-5-1/8	Presser Foot Bottom, marked "AK-5 1/8", for No. 5-1/8 gauge-----	1
-	39630 F-12-3/16	Presser Foot Bottom, marked "AK-12 3/16", for No. 12-3/16 gauge -----	1
47	39630 M	Hinge Screw, for needle hole section -----	1
48	39630 H	Needle Hole Section, marked "AT", for No. 5-1/8 gauge ----	1
-	39630 K	Needle Hole Section, marked "AR", for No. 12-3/16 gauge --	1
49	39620 F-5-1/8	Presser Foot, for No. 5-1/8 gauge, Styles 39600 CP and CQ-----	1
-	39620 F-12-3/16	Presser Foot, for No. 12-3/16 gauge, Styles 39600 CP and CQ---	1
49A	39620 G-5-1/8	Presser Foot, bottom marked "BL", for No. 5-1/8 gauge, Styles 39600 CR and CS-----	1
-	39620 G-12-3/16	Presser Foot, bottom marked "BK", for No. 12-3/16 gauge, Styles 39600 CR and CS-----	1
50	39630 W	Presser Foot Shank, marked "G", for No. 5-1/8 gauge-----	1
-	39630 X	Presser Foot Shank, marked "F", for No. 12-3/16 gauge---	1
51	22781	Clamp Screw-----	1
52	39630 L	Lock Nut -----	1
53	39630 AB	Spring-----	1
54	22799 Y	Hinge Screw, for presser foot bottom-----	1
55	39630 T-5-1/8	Presser Foot Bottom, marked "BL", for No. 5-1/8 gauge---	1
	39630 T-12-3/16	Presser Foot Bottom, marked "BK", for No. 12-3/16 gauge-----	1
56	39678 X	Chip Deflector, marked "A", for No. 5-1/8 gauge, Styles 39600 CP and CQ-----	1
-	39678 Y	Chip Deflector, marked "B", for No. 12-3/16 gauge, Styles 39600 CP and CQ -----	1
56A	39678 Z	Finger Guard, marked "C", for Styles 39600 CR and CS-----	1
57	22768 B	Screw, for chip deflector or finger guard -----	1
58	39630 M	Hinge Screw, for needle hole section -----	1
59	39630 U	Needle Hole Section, marked "AV", for No. 5-1/8 gauge ----	1
	39630 V	Needle Hole Section, marked "AU", for No. 12-3/16 gauge --	1

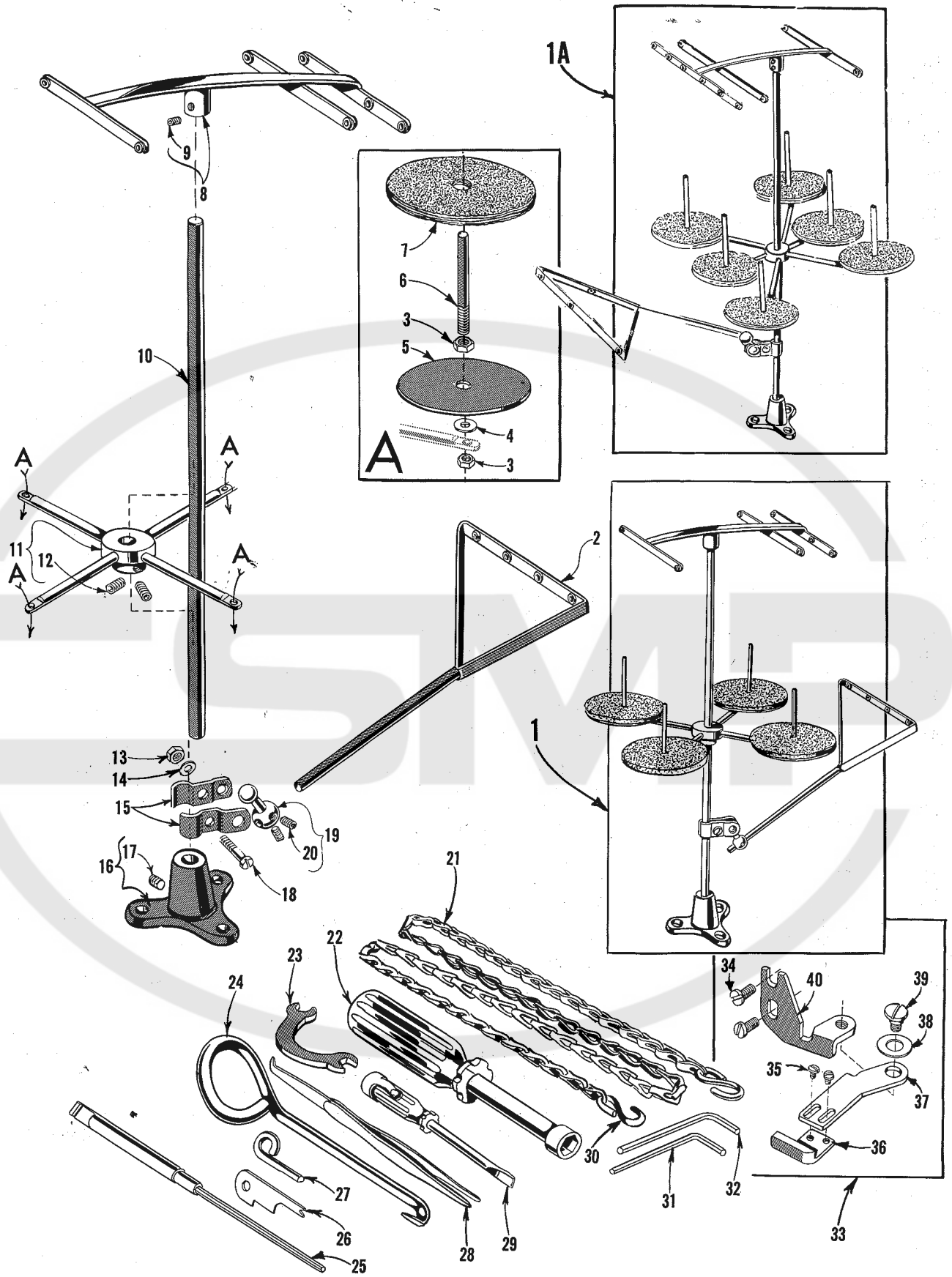

THREAD STAND AND ACCESSORIES

<u>Ref. No.</u>	<u>Part No.</u>	<u>Description</u>	<u>Amt. Req.</u>
1	21101 H-4	Thread Stand, complete, for 4 cones, for Styles 39600 CA, CP and CR -----	1
†1A		Thread Stand, complete, for 6 cones, for Styles 39600 CB, CQ and CS -----	1
2	21114 S-4	Lead Eyelet, for No. 21101 H-4 -----	1
-	21114 AL-5	Lead Eyelet, for 5 threads -----	1
3	258 A	Nut -----	8 or 10
4	652-16	Washer -----	4 or 5
5	21114	Spool Seat Disc -----	4 or 5
6	21114 W	Spool Pin -----	4 or 5
7	21104 V	Pad, for thread cone -----	4 or 5
8	21114 H-4	Eyelet Support, for No. 21101 H-4 -----	1
-	21114 H-6	Eyelet Support, for 6 threads -----	1
9	22651 CD-4	Screw -----	1
10	21104 B-24	Thread Stand Rod -----	1
11	21114 D-4	Spool Seat Support, for No. 21101 H-4 -----	1
-	21114 D-6	Spool Seat Support, for 6 threads -----	1
12	22651 CD-5	Screw -----	2
13	21104 H	Nut -----	1
14	652-16	Washer -----	1
15	21114 U	Lead Eyelet Ball Split Socket -----	2
16	21114 A	Thread Stand Base -----	1
17	22651 CD-4	Screw -----	1
18	22810	Clamp Screw -----	1
19	21114 T	Lead Eyelet Socket Ball -----	1
20	22651 CD-4	Screw -----	2
21	421 D-34	Foot Lifter Treadle Chain, 34 inches long -----	1
22	21388 AU	Socket Wrench, for 3/8 inch hexagonal nut holding feed eccentric -----	1
23	21388 W	Wrench, curved double end, 9/32 inch opening -----	1
24	21227 BF	Feed Eccentric Extract or Hook -----	1
*25	21209 K	Hexagon Socket Bit, 7/64 inch hexagonal (for use with handle No. 21209 G) -----	1
*26	21225-3/64	Looper Gauge, 3/64 inch, for 401 stitch -----	1
* -	21225-1/8	Looper Gauge, 1/8 inch, for 503 or 504 stitch -----	1
*27	21227 CR	Needle Height Setting Gauge, for 401 stitch -----	1
28	660-272	Thread Tweezers -----	1
29	21207 B	Screwdriver, 1/8 inch diameter -----	1
30	660-264	"S" Hook, for treadle chain -----	2
31	WR 64	Wrench, 3/32 inch hexagonal -----	1
32	WR 70	Wrench, 7/64 inch hexagonal -----	1
*33	29481 J	Edge Guide Assembly -----	1
34	22569 C	Screw, for edge guide mounting bracket -----	2
35	604	Screw, for edge guide -----	2
36	39503 A	Edge Guide -----	1
37	39603 A	Edge Guide Swinging Arm -----	1
38	12957 E	Spring Washer -----	1
39	22758 E	Screw, for edge guide swinging arm -----	1
40	39603	Edge Guide Mounting Bracket -----	1

* Available as extra send and charge item.

† Number for complete thread stand not available, order component parts.

NUMERICAL INDEX OF PARTS

<u>Part No.</u>	<u>Page No.</u>	<u>Part No.</u>	<u>Page No.</u>	<u>Part No.</u>	<u>Page No.</u>
WO-3	25	21114 D-6	43	22824	23
22 KH	31	21114 H-4	43	22825	37
28 B	29	21114 H-6	43	22829	33, 37
40-46	25, 29	21114 S-4	43	22847 B	39
51-103 Blk	37	21114 T	43	22849 A	37
51-228 Blk	25	21114 U	43	22892 B	35
WR64	43	21114 W	43	22894 C	31, 33
CO67 E	25	21114 AL-5	43	22894 D	25
WR70	43	21207 B	43	22894 J	31
73 X	39	21209 K	43	22894 AD	23, 31
77	31	21225-3/64	43	29477 HU	23
86 X	23	21225-1/8	43	29477 JN	25
87	29	21227 BF	43	29477 JU	25
87 U	25, 29, 31, 37	21227 CR	43	29477 JV	25
88	39	21388 W	43	29477 JZ	23
88 F	35	21388 AU	43	29480 LS	25
90	23, 35, 37	22503 F	31, 35	29481 J	43
93	27	22519 H	29	39151	31
93 A	27, 29	22524	35	39158 U	23
95	25	22541	37	39270 D	33
97	31	22562 A	31, 33, 37	39270 E	33
97 A	25	22564 D	35	39501 K	23
98	33	22564 G	31	39501 DF	23
138	23	22565	23, 31	39503 A	43
154 GAS	29	22565 C	33	39508 A	31
158 GJS	29	22565 F	27	39508 B	31
187 A	35	22565 H	31	39516-625	25
258	25, 29	22565 L	31	39516-626	25
258 A	39, 43	22566 B	39	39516-627	25
376 A	41	22569	23	39521 C	25
421 D-34	43	22569 B	25, 27, 29,	39521 D	25
482 C	31, 33		41	39525 A	35
531	29	22569 C	37, 43	39532 A	23
538	31, 33	22569 D	23	39534	27
604	43	22569 G	27	39534 H	27
605	37, 39	22570 A	37	39534 R	23
627	39	22570 B	37	39534 GA	27
652-16	43	22571 E	23	39535 C	27
660-142	39	22585 A	35	39535 D	27
660-206	31, 33	22586 R	23	39535 J	27
660-207	29	22587 E	33	39536 B	27
660-210	23	22587 M	25	39536 C	29
660-219 N	37	22588 J	33	39536 E	29
660-243	23	22596 G	25	39536 AE	29
660-264	43	22597 E	39	39536 AF	29
660-268	25	22650 CB-4	33	39538	27
660-272	43	22651 CD-4	43	39540 B-9	29
666-94	25	22651 CD-5	43	39540 B-10	29
666-255	31	22653 B-12	35	39540 B-11	29
667 D-8	23	22653 D-4	23	39541 A	25
667 H-16	23	22653 J-4	35	39543	31
1025 L	31	22657 D-12	23	39543 A	31
1280	31	22729 B	35	39543 E	31, 35
6042 A	33	22729 D	31, 33	39543 H	31
		22729 E	31, 33	39543 K	31
8372 A	29, 39	22738	35	39543 M	31, 33
12538	39	22747 B	25	39543 P	31, 33
12865	39	22757 E	37	39543 R	31
12957 E	43	22758 E	43	39543 S	31
12982	31	22768	29	39543 T	31
14077	35	22768 B	41	39543 U	31
21101 H-4	43	22769 B	25	39543 V	31
21104 B-24	43	22775	35	39543 X	31
21104 H	43	22781	35, 41	39544	31
21104 V	43	22784 E	29	39544 B	31
21114	43	22791 H	39	39544 D	31
21114 A	43	22799 U	41	39544 J	31
21114 D-4	43	22799 Y	41	39544 L	25
		22806 A	39	39544 U	31
		22810	43		

NUMERICAL INDEX OF PARTS

<u>Part No.</u>	<u>Page No.</u>	<u>Part No.</u>	<u>Page No.</u>	<u>Part No.</u>	<u>Page No.</u>
39544 V	31	39592 AA	39	39644 E	35
39549	33	39592 AB	39	39644 F	31
39549 J	33	39592 AC	39	39644 K	33
39550 C	35	39592 AD	39	39644 L	35
39550 E	35	39592 AF	39	39644 M	33
39550 M	33	39592 AG-5	39	39644 N	33
39550 Z	33	39592 AH	39	39644 P	33
39552 C	29	39592 AJ	39	39644 R-2	31, 33
39552 P	25	39592 AK	39	39644 R-5	31, 33
39552 R	29	39592 AL	39	39644 S	25
39552 U	25	39592 AN	39	39644 U	33
		39592 AR-2	39	39644 W	35
39555 B	39	39592 AR-4	39	39644 X	31, 33
39555 C	39	39592 AR-5	39	39650	35
39555 D	39	39593 C	23	39650 A	35
39555 E	25	39593 D	23	39652-5	29
39555 F	39	39593 H	23	39652-12	29
39555 N	25	39594 G	23	39652 B	29
39556 A	37	39594 H	23	39652 C	29
39557	37	39594 N	25, 29, 31	39655	39
39557 A	37	39594 R	23	39656 A	39
39557 B	37	39595	23	39656 B	39
39557 C	37	39603	43	39663 H	37
39557 E	37	39603 A	43	39663 J	37
39557 F	37	39605 F-5-1/8	27	39663 K	37
39560 A	31	39605 F-12-3/16	27	39663 L	29
39568 B	41	39605 G-5-1/8	27	39668 C	37
39568 D	41	39605 G-12-3/16	27	39668 D	37
39568 E	41	39605 H-5-1/8	27	39668 E	37
39568 L	41	39605 H-12-3/16	27	39668 F	37
39570 K	35	39608 C	35	39668 G	37
39571 A	33	39620 C-5-1/8	41	39668 H	37
39571 B	35	39620 C-12-3/16	41	39668 J	29
39571 C	35	39620 F-5-1/8	41	39668 K	37
39571 E	33	39620 F-12-3/16	41	39668 L	37
39571 F	35	39620 G-5-1/8	41	39668 W	39
39572 A	35	39620 G-12-3/16	41	39668 BA	37
39572 B	33	39624 F-5-1/8	35	39673	33
39573 A	33	39624 F-12-3/16	35	39673 A	33
39573 E	33			39673 C	23
39573 K	25	39625 B	35	39678 P	35
39573 AA	25	39625 C	35	39678 U	23
39578 F	23	39626 C	27	39678 X	41
39578 M	29	39626 D	27	39678 Y	41
39578 P	29	39626 E	27	39678 Z	41
39580 AC	35	39626 F	27	39678 AB	23
39582 F	23	39626 G	27	39678 AC	23
39582 V	37	39626 H	27	39680	27
39582 W	37	39630 F-5-1/8	41	39690	25
39582 Y	23	39630 F-12-3/16	41	39690 A	25
39582 AE	37	39630 G	41	39690 B	25
39582 AF	37	39630 H	41	39691	25
39582 AG	37	39630 J	41	39694	31
39582 AJ	37	39630 K	41	39825 C	35
39582 DA	23	39630 L	41	39855	39
39582 XD	23	39630 M	41	39878 C	23
39590	25	39630 T-5-1/8	41	41071 G	23
39590 G	25	39630 T-12-3/16	41	41336 C	35
39590 H	25	39630 U	41	43139 A	41
39590 J	25	39630 V	41	43143 N	31
39590 N	25	39630 W	41	43443 Q	23
39590 R	25	39630 X	41	51758	37
39590 S	25	39630 AB	41	52958	37
39590 T	25	39630 AC	41	53634 C	27, 37
39591 H	25	39635	27	53678 N	37
39591 K	25	39644	33	55235 D	33
39591 L	25	39644 A	33	55235 E	33
39592 Y	39	39644 C	25		
39592 Z	39				







Union Special
INDUSTRIAL SEWING EQUIPMENT