

CATALOG NO.

395M

First Edition

**STYLES**

395-20

395-21

395-22

395-23

395-26

395-26V

395-28

395-28V

395-40

395-40V

395-42

395-42V

# Adjusting instructions and illustrated parts list



**6M Classic Series**  
**-Differential feed overseamers**

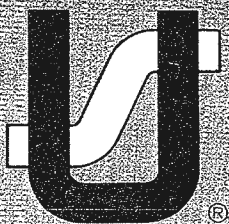

Finest Quality

*Union Special*<sup>®</sup>  
Industrial Sewing Equipment

ADJUSTING INSTRUCTIONS AND  
ILLUSTRATED PARTS LIST ON  
6M CLASSIC SERIES - DIFFERENTIAL  
FEED OVER SEAMING MACHINES

Catalog No. 395 M

For Styles

395-20	395-28
395-21	395-28V
395-22	395-40
395-23	395-40V
395-26	395-42
395-26V	395-42V

First Edition

Copyright 1981

By

Union Special Corporation

Rights Reserved In All Countries

Printed In U.S.A.

September, 1981

## FOREWORD

This technical manual has been prepared to guide you in the maintenance of your new UNION SPECIAL machine. Careful attention to the instructions for operating and adjusting these machines will enable you to maintain the superior performance and reliability designed and built into every UNION SPECIAL machine.

The Adjusting Instructions portion of this manual explains in detail the proper setting for each of the components related to forming the stitch and completing the functions of the machine. The text of the Adjustments is divided into two sections - Check and Procedure. The Check depicts conditions when the parts are adjusted correctly. The Procedure is given to explain the proper steps to be taken in the event adjustments are required. Figures are used to illustrate the adjustments using reference letters to point out specific items discussed.

Adjustments are presented in sequence so that a logical progression is accomplished. Some adjustments performed out of sequence may have an adverse effect on the function of other related parts.

Implementation of preventative maintenance procedures can bring about significant improvements in operator productivity by avoiding costly equipment breakdowns. Whenever it becomes necessary to make repairs or replace parts on your machine, be sure to insist on genuine UNION SPECIAL Repair Parts. These parts are designed specifically for your machine and manufactured with utmost precision to assure long lasting service.

To simplify identification of repair parts, the mechanisms are illustrated by exploded views. These illustrations will usually be shown in conjunction with a KEY VIEW which presents the mechanisms of the machine assembled. The specific parts illustrated on this page will appear shaded in the KEY VIEW.

## CLASS DESCRIPTION

High Speed, one and two curved needles, two, three and four thread, differential feed overseaming machines. Fabric trimmer with spring pressed lower knife. Independent cam driven main and differential feeds. Enclosed automatic lubrication system.

### TECHNICAL DATA

STITCH AND SEAM TYPE.....	503 EFc-1, Styles 395-20, 21. 504 SSa-1, Styles 395-26, 26V, 28, 28V, 40, 40V, 42, 42V. 512 SSa-1, Styles 395-22, 23.
FEED SYSTEM.....	Independent, Cam Driven Main and Differential Feeds.
MAXIMUM SPEED..... (Depending on operation)	6000 RPM, All Styles.
LUBRICATION.....	Enclosed Automatic Splash System, Single Reservoir.

### MACHINE STYLES

- 395-20 - One needle, two thread machine produces break open seam. Fitted with compact hemmer assembly with overhanging hem guides. Typical Application - Flat or circular blind hemming/welting operations on "T" shirts. Available seam width: 1/8 inch (3.2mm).
- 395-21 - Same as Style 395-20 except extra stitch cams and needles are furnished.
- 395-22 - Two needle, four thread machine prepared with high throw crankshaft. Produces simulated "Safety Stitch". Typical Application - Seaming bathing suits, dresses and draperies. Available seam width: 17/64 inch (6.7mm)
- 395-23 - Same as Style 395-22 except extra stitch cams and needles are furnished.
- 395-26 - One needle, three thread machine prepared with high throw crankshaft. Typical Application - For curved seams on knit undergarments. Available seam widths: 3/32 inch (2.4mm), 1/8 inch (3.2mm), 5/32 inch (3.9mm).
- 395-26V - Same as Style 395-26 except fitted with "AIR-KLIPP"® chain cutter.
- 395-28 - Same as Style 395-26 except extra stitch cams and needles are furnished.
- 395-28V - Same as Style 395-28 except fitted with "AIR-KLIPP" chain cutter.
- 395-40 - One needle, three thread machine prepared with low throw crankshaft. Typical Application - For curved seams on knit undergarments. Available seam widths: 3/32 inch (2.4mm), 1/8 inch (3.2mm), 5/32 inch (3.9mm).
- 395-40V - Same as Style 395-40 except fitted with "AIR-KLIPP" chain cutter.
- 395-42 - Same as Style 395-40 except extra stitch cams and needles are furnished.
- 395-42V - Same as Style 395-42 except fitted with "AIR-KLIPP" chain cutter.

## IDENTIFICATION OF MACHINES

Each UNION SPECIAL machine carries a style number, which on this class machine is stamped in the style plate located to the right rear of the machine.

The serial number is stamped in the extension of casting at the right rear base of machine.

### SAFETY RULES



CAUTION!

THIS SAFETY SYMBOL INDICATES YOUR PERSONAL SAFETY IS INVOLVED.

TO PREVENT PERSONAL INJURY:

- All power sources to the machine MUST be TURNED OFF before threading, oiling, adjusting or replacing parts.
- Wear safety glasses.
- All shields and guards MUST be in position before operating machine.
- DO NOT tamper with safety shields, guards, etc., while machine is in operation.

### LUBRICATION

Oil capacity of Class 395 is eight ounces (227 milliliters). Use a straight mineral oil with a Saybolt viscosity of 90 to 125 seconds at 100 degrees F. This is equivalent to UNION SPECIAL specification No. 175.

Machine is filled with oil at spring cap in top cover. Before operating, check oil level at sight gauge on front of machine. When proper oil level is reached, red bulb on oil level indicator will register between red gauge lines.

To drain oil remove magnetic plug from back of machine near bottom edge of base. Clean magnetic plug of any metallic material that may have accumulated in crankcase. Oil MUST be changed periodically to minimize wear.

### THREADING

Before threading machine; unlock presser foot release bushing, swing presser arm and cloth plate out of position and pull upper looper thread tube up. Turn handwheel in operating direction until needle is at highest position. Thread tweezers No. 660-240 are furnished with machine to aid in threading.

Be sure machine is threaded properly according to the threading diagrams shown on the following pages. Use Figure 1 for Styles using two threads, Figure 1A for Styles using three threads and Figure 1B for two needle Styles using four threads.

Thread machine in the following sequences: (1) lower looper thread (2) upper looper thread, two thread styles DO NOT require this step. (3) needle(s).

**THREADING DIAGRAM FOR TWO THREAD  
STYLES 395-20 AND 21**

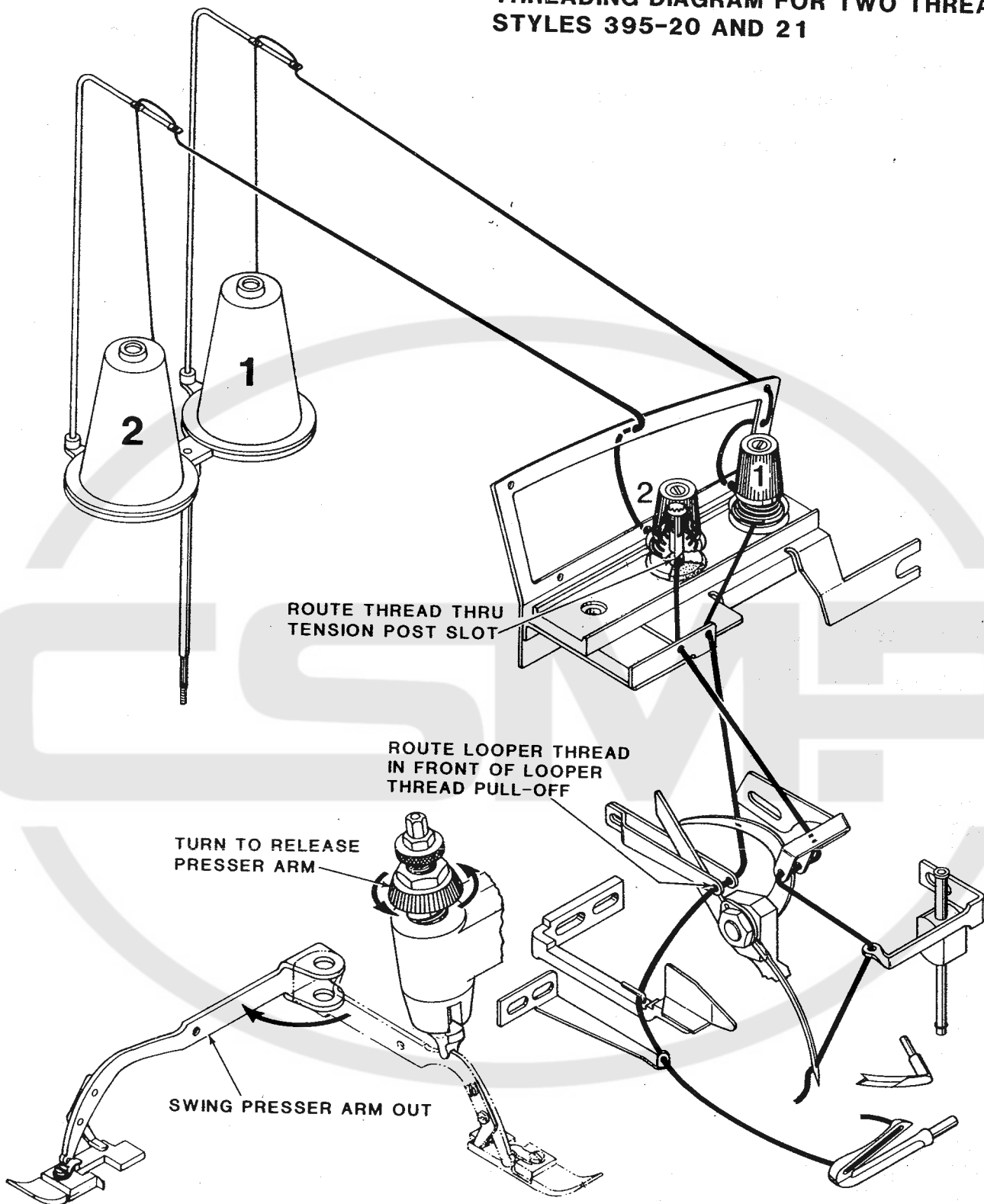

Fig. 1

**THREADING DIAGRAM FOR THREE THREAD  
STYLES 395-26, 26V, 28, 28V, 40, 40V, 42 AND 42V**

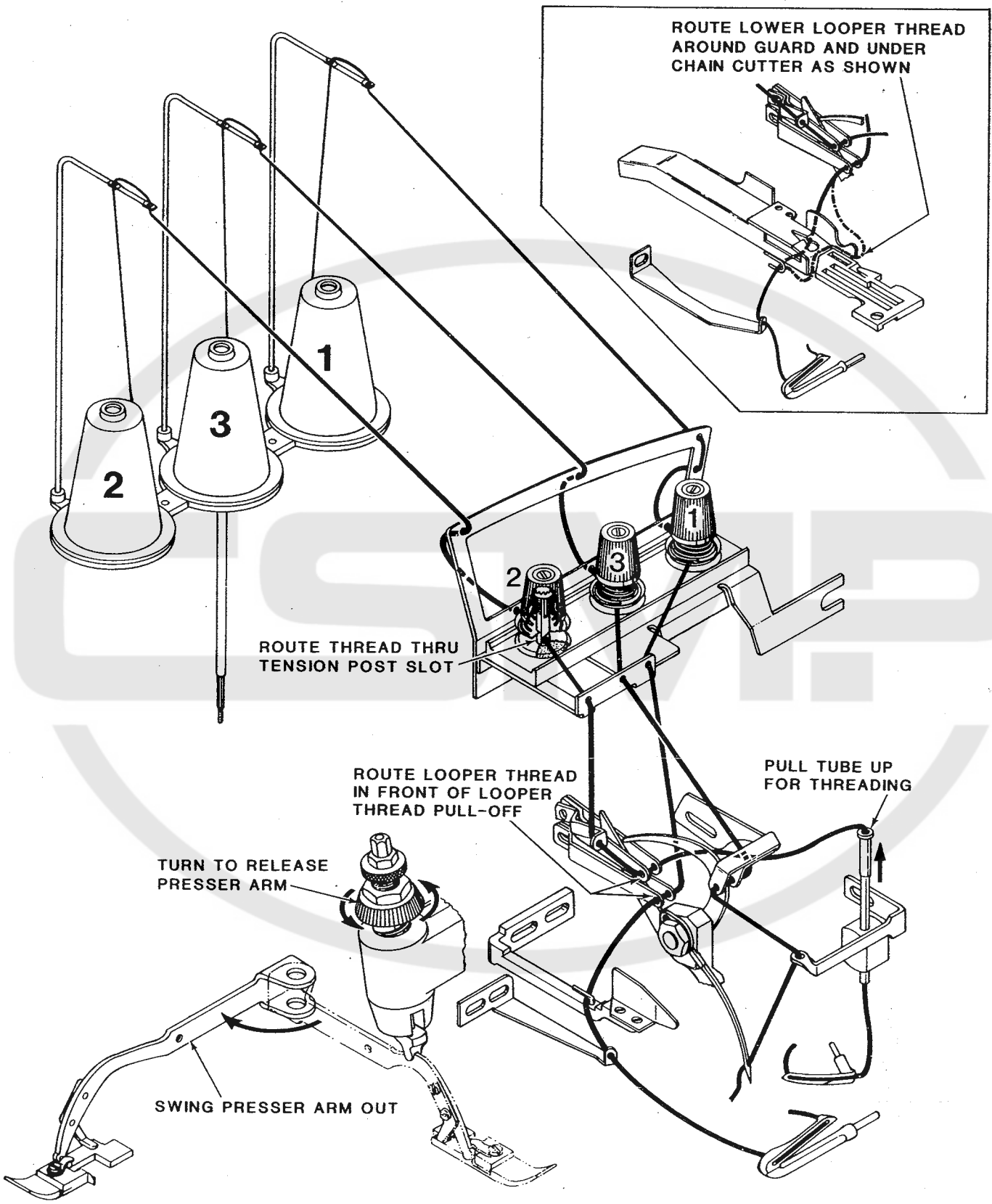

Fig. 1A

**THREADING DIAGRAM FOR FOUR THREAD  
STYLES 395-22 AND 23**

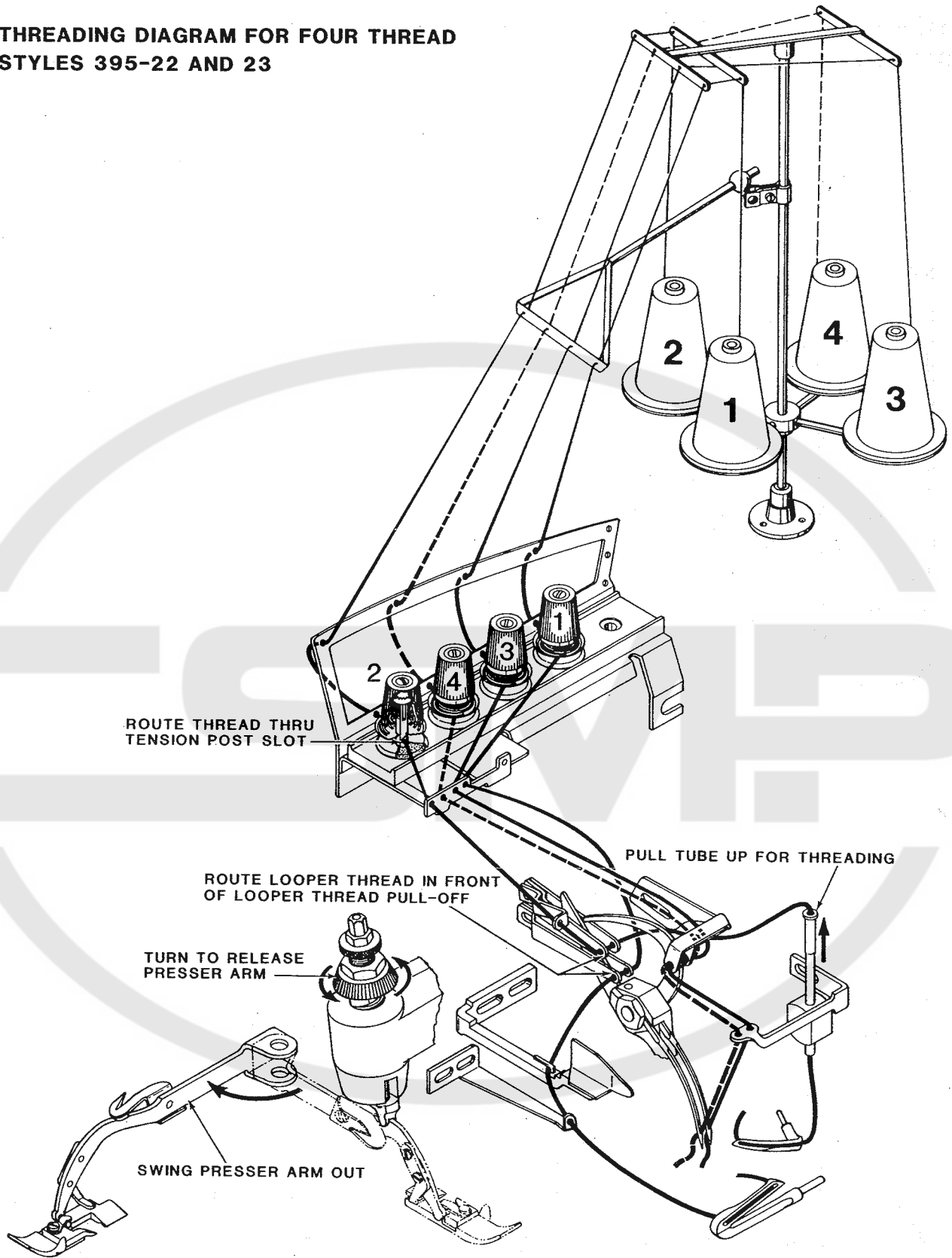

Fig. 1B



## ADJUSTING INSTRUCTIONS CLASS 395 MACHINES

**NOTE:** Instructions stating direction or location, such as right, left, front or rear of machine, are given relative to operator's position at the machine. During operation, the handwheel must rotate in a clockwise direction - viewed from the right end of machine.

### NEEDLES

EXAMINE NEEDLE(S) TO ASSURE PROPER TYPE AND SIZE IS BEING USED. THE FOLLOWING CHECKS RELATED TO NEEDLE(S) MUST BE MADE BEFORE ADJUSTING THE NEEDLE(S), LOOPERS OR NEEDLE GUARDS. DISCARD AND REPLACE ANY DEFECTIVE NEEDLE(S).

- Place a new needle of the same type and size alongside the existing needle to check curvature of needle blade as shown (A, Fig. 2).
- Apply the thumbnail test to check for bluntness and/or hooks on the tip of needle(s) as shown (B, Fig. 2).
- Check for any sharpness around eye and/or grooves of needle(s). For a quick check, pull the thread up and down back and forth through the needle eye as shown (C, Fig. 2). If any sharpness exists, it will shred and sever the thread.
- Be sure needle(s) is all the way up in needle holder and positioned correctly with the spot or scarf to the rear as shown (D, Fig. 2).

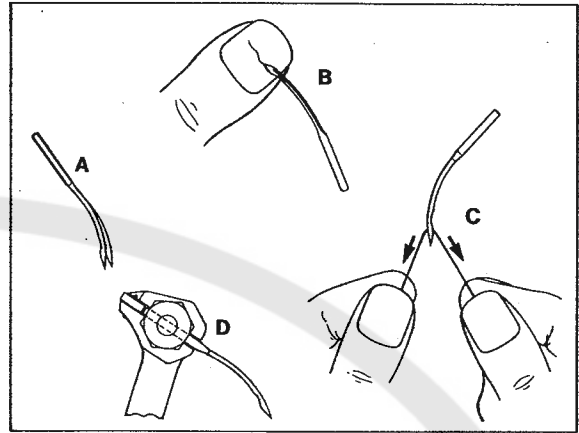

Fig. 2

Machines are sewn off and shipped from the factory with needle(s) listed in chart per machine style:

<u>Machine Style</u>	<u>Type and Size</u>
395-20, 21, 26, 26-V, 28, 28-V, 40, 40-V, 42, 42 V.	154 GAS-070/027
395-22, 23	154 GAS-090/036

The following chart lists additional needle types and sizes available for Class 395 machines.

<u>NEEDLE TYPE</u>	<u>DESCRIPTION</u>	<u>SIZES AVAILABLE</u>
154 GAS	Round shank, round point, curved blade, standard length, single groove, struck groove, spotted, chromium plated.	055/022, 065/025, 070/027, 075/029, 080/032, 090/036, 100/040, 110/044, 125/049, 140/054, 150/060.
154 GBS	Same as 154 GAS except it has a double groove.	070/027, 075/029, 080/032.

<u>NEEDLE TYPE</u>	<u>DESCRIPTION</u>	<u>SIZES AVAILABLE</u>
154 GES	Same as 154 GAS except it has a shorter blunt point.	055/022, 065/025, 070/027, 075/029, 080/032, 090/036, 100/040, 110/044, 125/049, 140/054, 150/060
154 GHS	Same as 154 GAS except it has a ball point.	065/025, 070/027, 075/029, 080/032, 090/036
154 GJS	Same as 154 GAS except it has a tapered blade.	055/022, 065/025, 070/027, 075/029, 080/032, 090/036, 100/040
154 GLS	Same as 154 GAS except it has a ball eye.	070/027, 075/029, 080/032, 090/036, 100/040

To have needle orders promptly and accurately filled, an empty package, a sample needle or type and size number should be forwarded. Use description on label. A complete order would read "1000 needles, Type 154 GAS, Size 075/029".

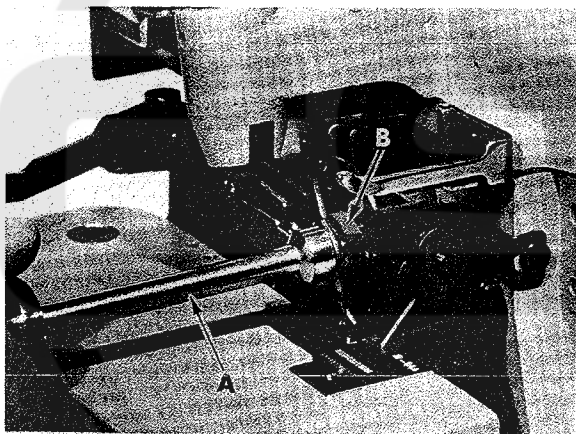

Fig. 3

#### NEEDLE REPLACEMENT

Rotate presser foot release bushing counterclockwise and swing presser foot to the left. Turn handwheel in operating direction until needle(s) is at lowest position. Loosen clamp nut using socket wrench No. 21388 A (A, Fig. 3), then remove needle(s).

Turn handwheel until needle holder (B) is at highest position. Insert new needle(s) all the way up in needle holder with spot or scarf to the rear. Tighten clamp nut, swing presser foot to the right and lock foot into sewing position with presser foot release bushing.

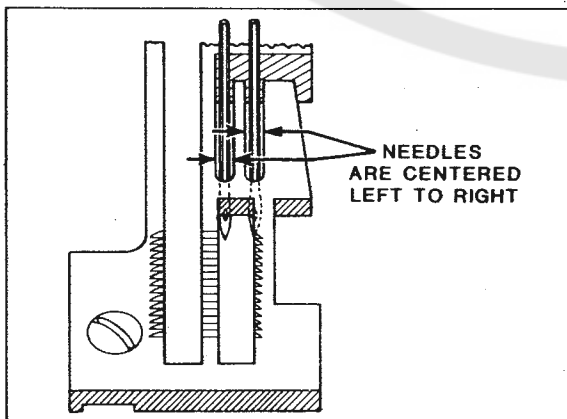

Fig. 4

#### NEEDLE ALIGNMENT

Check:

Needle(s) must enter the center of needle slot(s) (left to right) in throat plate as shown in Fig. 4. If adjustment is necessary, remove fabric guard and looper thread pull-off.

### Procedure:

Loosen needle driving arm clamp screw (A, Fig. 5) and center needle(s) in needle slot(s) of throat plate by adjusting needle driving arm (B) left to right as required. Temporarily tighten clamp screw (A), then proceed to needle height adjustment.

### NEEDLE HEIGHT

### Check:

Rotate handwheel in operating direction until needle(s) is at highest position. The needle height measurement from point of needle(s) to top of throat plate must be 1/2 inch (12.7mm) as shown in Fig. 5.

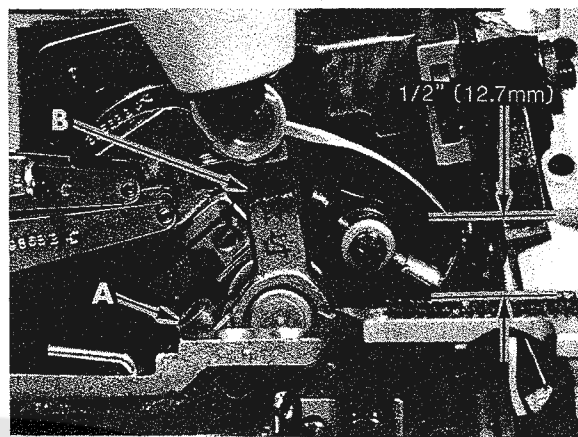

Fig. 5

### Procedure:

Loosen clamp screw (A) and adjust needle driving arm (B) front to back as required to obtain needle height shown in Fig. 5, then tighten clamp screw (A) and replace looper thread pull-off.

PRIOR TO MAKING THE FOLLOWING ADJUSTMENT; REMOVE CLOTH PLATE, CHIP GUARD, UPPER KNIFE, MAIN, DIFFERENTIAL AND CHAINING FEEDS. REMOVE HEMMER ASSEMBLY ON STYLES 395-20 and 21.

### CLOTH PLATE

Remove cloth plate (A, Fig. 6) by loosening screw (B) and lifting upward with stud (C) and screw (D) still assembled to plate.

Before replacing cloth plate, hold stud (C) and tighten screw (D) only enough to remove end play, yet allowing cloth plate to swing open when assembled. Assemble cloth plate to machine by inserting stud (C) with flat and "V" notch to the rear into hole of machine bed. Tighten screw (B) to press "V" notch of stud (C) against screw (D).

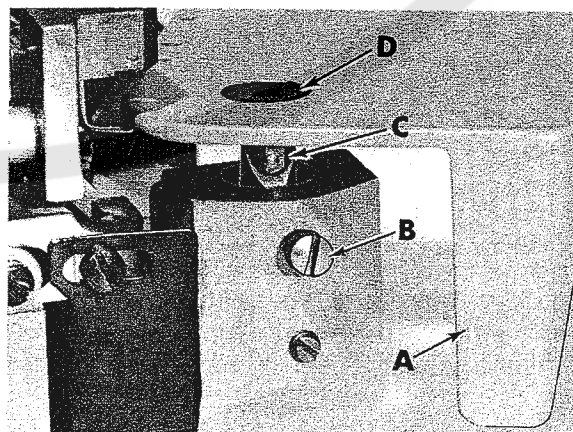

Fig. 6

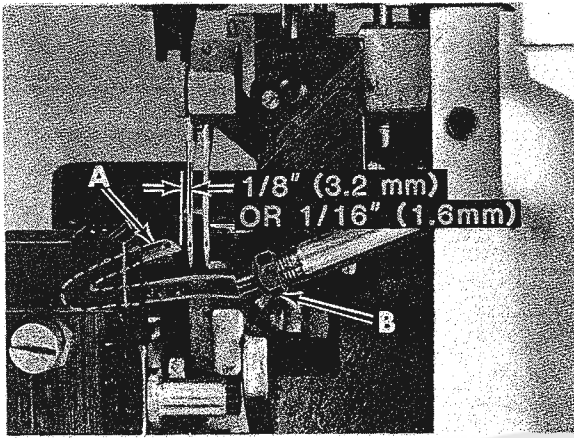

Fig. 7

Left needle on Styles 395-22 and 23. needle(s):

Procedure:

PRIOR TO ADJUSTING LOOPER, POSITION UPPER LOOPER UP AND AWAY FROM LOWER LOOPER.

Gauge No. 21225-1/8 or 21225-1/16 should be used to properly set looper gauge.

Position lower looper (A) to extreme right and loosen clamp nut (B). Then position looper to extreme left and set looper gauge by adjusting looper in or out of the looper shaft to obtain 1/8 inch (3.2mm) or 1/16 inch (1.6mm) for Style 395-22 and 23. Rotate handwheel to position looper into scarf of needle or left needle on Style 395-22 and 23. Set looper point to touch but NOT deflect needle(s), then position looper to extreme right and tighten clamp nut (C).

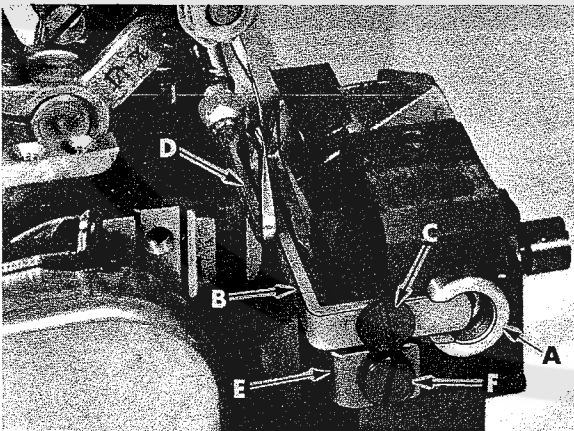

Fig. 8

needle(s) while also setting guard as low as possible to prevent it from interfering with needle thread as loop is being formed to rear of needle(s), then tighten screw (C) securely.

Guard must NOT interfere with lower knife holder movement or contact lower looper at any point of travel.

## LOWER LOOPER

Check:

PRIOR TO CHECKING LOOPER ADJUSTMENT; REMOVE FRONT AND REAR NEEDLE GUARDS.

LOOPER GAUGE - With looper at extreme left position, 1/8 inch (3.2mm) is the distance between looper point and centerline of needle; 1/16 inch (1.6mm) to left needle on Styles 395-22 and 23, as shown in Fig. 7.

LOOPER CLEARANCE TO NEEDLE(S) - Turn handwheel in operating direction so that looper travels from the extreme left into scarf of needle or Point of looper should touch but NOT deflect

## REAR NEEDLE GUARD

Remove spring from inside of lower knife holder (A, Fig. 8), then assemble knife holder into throat plate support block.

Replace rear needle guard (B) using screw (C) with front edge of guard centered in slot of knife holder as shown. Temporarily tighten screw (C) to hold guard in position, yet allowing guard to be adjusted.

Rotate handwheel in operating direction so lower looper (D) travels from the extreme left into scarf of needle(s). Set guarding surface of guard (B) to touch but NOT deflect

## FRONT NEEDLE GUARD

Replace front needle guard (E, Fig. 8) using screw (F). Temporarily tighten screw (F) to hold guard in position, yet allowing guard to be adjusted.

Rotate handwheel in operating direction until needle(s) is at lowest position, then set guarding surface of guard (E) to needle(s) with minimum clearance - approximately .004 inch (.10mm) and tighten screw (F) securely. Check adjustment to ensure needle(s) is NOT being pinched between front and rear needle guards.

### UPPER LOOPER/SPREADER

PROPER ADJUSTMENT OF THE UPPER LOOPER/SPREADER IS ESSENTIAL FOR SUCCESSFUL MACHINE OPERATION. THE PATH TRAVELED BY THE UPPER LOOPER/SPREADER EFFECTS THE MAXIMUM SEAM THICKNESS SEWN.

Rotate handwheel in operating direction and closely observe the path of upper looper/spreader as it travels from the extreme right and approaches the lower looper as shown in Fig. 9. The point of upper looper/spreader MUST pass the notch in head of lower looper with minimum clearance and pass under lower looper thread.

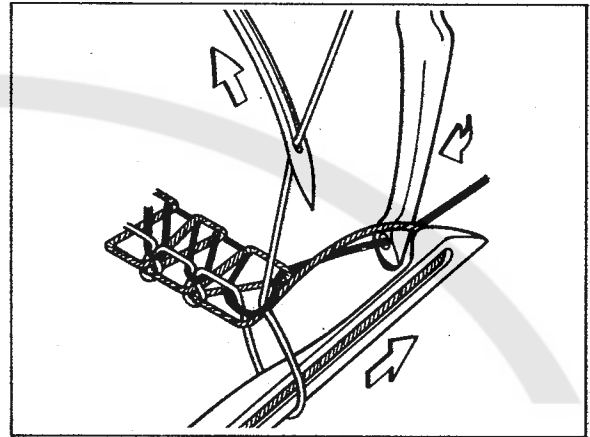

Fig. 9

Again rotate the handwheel until the upper looper/spreader is positioned to extreme left as shown in Fig. 10. At this time, point of upper looper/spreader MUST be in position so the descending needle or right needle will pass to the right of the upper looper/spreader thread, which extends from the eye of the looper to the previously formed stitch. The upper looper/spreader must NOT contact the lower looper or needle(s) at any point of travel.

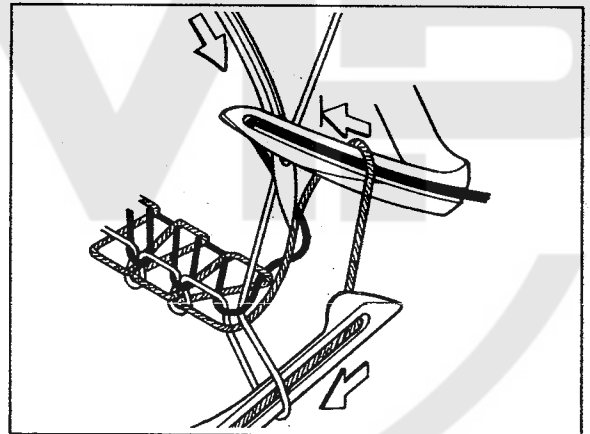

Fig. 10

Figures 11, 12, 13 and the following chart relate approximate dimensions for adjusting the upper looper/spreader at extreme right and left positions of travel.

MACHINE STYLE	SHANK EXTENDED DIM. "D" FIG. 11	HEIGHT ABOVE DIM. "E" FIG. 13	POINT OF LOOPERS/SPREADER TO DIM. "F" FIG. 13
395 All Styles except 395-22, 395-23	1/32 inch (.8mm)	31/64 inch (12.3mm)	5/32 inch (4mm)
395-22, 395-23	3/32 inch (2.4mm)	35/64 inch (13.9mm)	9/64 inch (3.6mm) (Right Needle)

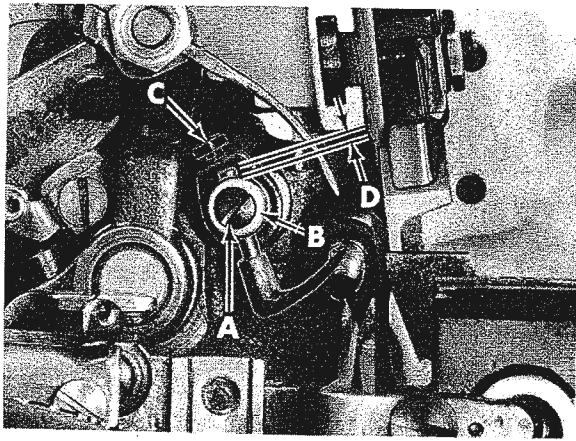

Fig. 11

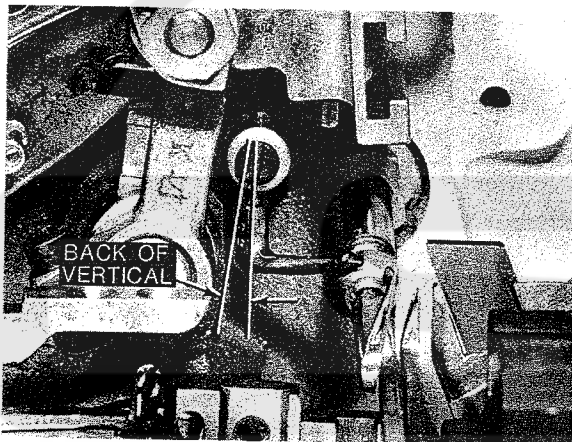

Fig. 12

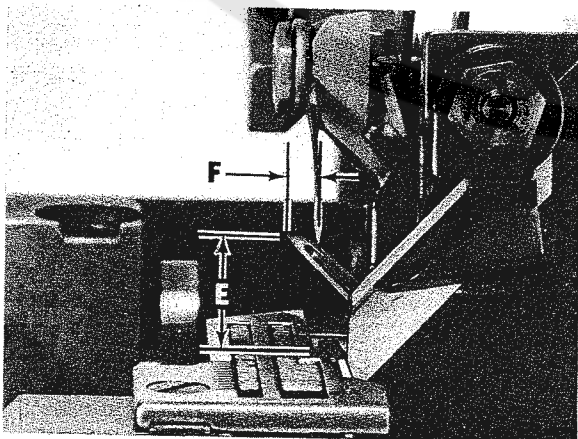

Fig. 13

To adjust upper looper/spreader, follow instructions listed in sequence as follows:

1. Position upper looper/spreader at the left end of travel, loosen clamp screw (A, Fig. 11) and set shank to dimension "D" Fig. 11 above holder (B), then temporarily tighten screw (A).
2. With upper looper/spreader positioned at the right end of travel, loosen screw (C) and rotate holder (B) as required to set shank slightly back of vertical as shown in Fig. 12, then temporarily tighten screw (C, Fig. 11).
3. Rotate handwheel in operating direction bringing the upper looper/spreader into the lower looper, See Fig. 9. Loosen screw (A, Fig. 11) and set the point of upper looper/spreader to enter the notched area behind head of lower looper with minimum clearance.
4. Again rotate handwheel in operating direction until the upper looper/spreader is at the extreme left end of travel. Loosen screw (C, Fig. 11) and rotate holder as required to set point of looper/spreader to dimension "E" Fig. 13 from top of throat plate.
5. With upper looper/spreader still positioned at the left end of travel, it may be necessary to adjust the holder in or out of its shaft to set point of looper/spreader to dimension "F" Fig. 13 to the left of needle and/or right needle centerline. Rotate handwheel to position upper looper/spreader to the right end of travel, then tighten screw (C, Fig. 11) and screw (A) securely.
6. If the needle(s) is being deflected by the upper looper/spreader, clearance to the needle(s) can be increased by reducing the length of shank above holder, See Step 1. It will then be necessary to slightly reduce the angle back of vertical, See Step 2. Also reset upper looper/spreader to lower looper, See Step 3. Reversing this procedure will position the upper looper/spreader closer to the needle(s).

## MAIN AND DIFFERENTIAL FEEDS

### ASSEMBLE MAIN, DIFFERENTIAL, CHAINING FEEDS AND THROAT PLATE TO MACHINE:

#### Check:

Rotate handwheel in operating direction until teeth of rising feeds are above the top surface of throat plate. The feeds should be level with the throat plate at this time. With feeds at highest position of travel, their teeth should extend approximately 3/64 inch (1.2mm) above throat plate as shown in Fig. 14.

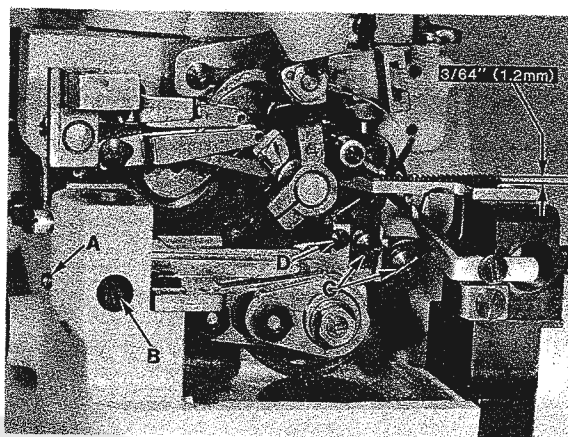

Fig. 14

#### Procedure:

Loosen lock screw (A, Fig. 14) and rotate tilt adjusting pin (B) as required to level feeds, then tighten lock screw (A).

Loosen feed attaching screws (C) and adjust feeds up or down to obtain proper height above throat plate as shown in Fig. 14, then tighten screws (C).

On all Styles fitted with separate chaining feeds, with feeds at highest position, loosen screw (D) and set height of chaining feed even with the stitch tongue of throat plate, then tighten screw (D).

## LOWER KNIFE

### INSERT SPRING BACK INTO LOWER KNIFE HOLDER AND ASSEMBLE HOLDER TO THROAT PLATE SUPPORT.

#### Check:

Cutting edge of knife (A, Fig. 15) must be even and parallel with top surface of throat plate. Examine sewn sample for specified seam width and appearance.

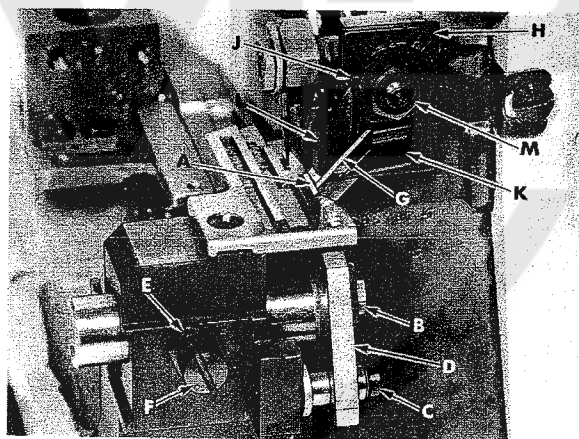

Fig. 15

#### Procedure:

Loosen screw (B) and adjust knife (A) up or down until its cutting edge is flush with top of throat plate, then tighten screw (B).

If cutting edge of knife is tilted, loosen screw (C) and rotate holder (D) front to rear as required, then tighten screw (C). Holder MUST move freely, left to right, and NOT bind with needle guard centered in slot of knife holder.

Adjust knife (A), left to right, by loosening locknut (E), screw (F) and set knife to specified seam width by measuring from center of needle to cutting edge of knife. Hold knife in this position and tighten screw (F). Adjust UPPER KNIFE; then sew-off on a piece of selected material to further check adjustment, by measuring the distance from needle penetration to edge of material. Readjust if necessary, to obtain specified seam width or appearance.

## UPPER KNIFE

REMOVE NEEDLE(S) AND RE-ASSEMBLE UPPER KNIFE HOLDER INTO SLOT OF UPPER KNIFE DRIVING ARM. ALSO RE-ASSEMBLE UPPER KNIFE IN HOLDER AND HOLD KNIFE FIRMLY IN POSITION.

### Check:

At lowest position the front tip of upper knife cutting edge must extend 1/64 - 1/32 inch (.4 - .8mm) below cutting edge of lower knife.

### Procedure:

With upper knife (G, Fig. 15) at lowest position of travel and while holding upper knife firmly against lower knife, adjust knife holder (H) left to right, to position front tip of upper knife cutting edge 1/64 - 1/32 inch (.4 - .8mm) below cutting edge of lower knife, then tighten screw (J).

Assemble knife clamp (K) and chain guard (L) in position using nut (M). Set chain guard (L) against top surface of upper knife and slightly back of its cutting edge, then tighten nut (M).

Loosen screw (F) to enable spring pressed lower knife to move freely left to right. If desired, the lower knife can be locked in position by tightening screw (F) against knife holder.

NOTE: Locking nut (E) must be tightened to hold screw (F) in position; screw (F) also serves as a latch pin for cloth plate.

## PRESSER FOOT ALIGNMENT

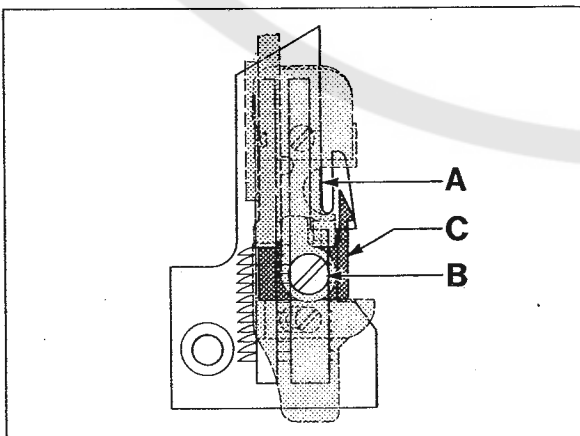

Fig. 16

LOCK THE PRESSER FOOT IN SEWING POSITION AND ROTATE HANDWHEEL UNTIL NEEDLE(S) IS AT LOWEST POSITION.

### Check:

Right edge of presser foot must align with left edge of needle slot in throat plate as shown Ref. Point A, Fig. 16.

Presser foot must lie flat on throat plate. The adjustable stitch tongue on presser foot must center over stitch tongue of throat plate as shown in Fig. 16.



## Procedure:

With presser foot locked in sewing position by release bushing (A, Fig. 17), loosen collar screws (B) and clamp screw (C), then adjust lifter lever shaft (D) left to right until the right edge of presser foot aligns with the left edge of needle slot in throat plate as shown Ref. point A, Fig. 16. Tighten collar screws (B, Fig. 17) and while holding lifter lever arm (E) so its stop screw (F) is against intermediate lever (G), tighten clamp screw (C).

Completely unlock release bushing (A, Fig. 17). Plunger should clear presser arm without binding.

Loosen screw (B, Fig. 16) and adjust stitch tongue (C) left to right, to center over stitch tongue of throat plate as shown in Fig. 16, then tighten screw (B).

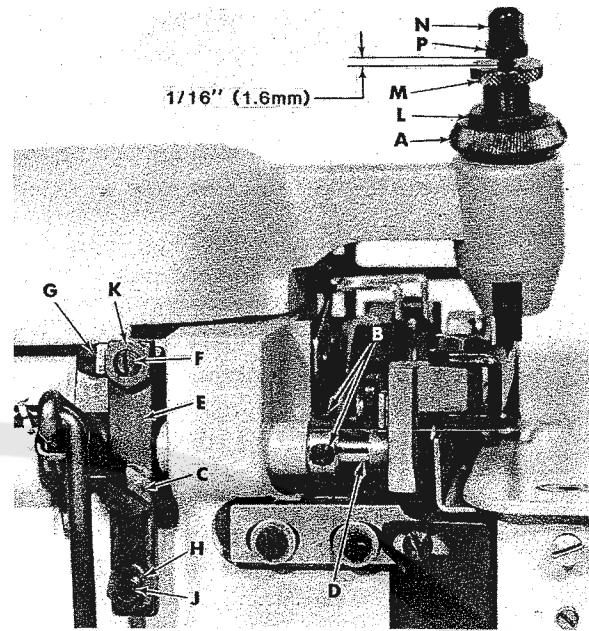

Fig. 17

## PRESSER FOOT LIFT

### Check:

Lift presser foot to highest position and rotate handwheel in operating direction. Upper looper must not contact presser foot at any point of travel.

### Procedure:

Loosen locknut (H, Fig. 17) and adjust stop screw (J) so presser foot will not interfere with upper looper, then tighten locknut (H).

Loosen locknut (K) and set stop screw (F) on upper end of lifter lever arm so there is approximately 1/16 inch (1.6mm) free motion in lifter lever before presser foot starts to rise, then tighten locknut (K).

## PRESSER FOOT PRESSURE

### Check:

Sufficient pressure must be maintained to feed work uniformly. Excessive spring pressure will cause feeds and presser foot to wear prematurely when chaining.

### Procedure:

Rotate handwheel in operating direction until both main and differential feeds are positioned below throat plate. Loosen locknut (L, Fig. 17) and turn adjusting screw (M) clockwise for more pressure or counterclockwise for less pressure, then tighten locknut (L).

NOTE: Adjusting screw (M) will effect the function of pressure release bushing (A). Plunger must clear presser arm when pressure release bushing is unlocked. When release bushing is locked in position, presser foot must be held firmly against throat plate. If these conditions do not exist the following adjustment must be made.

Lock presser foot in position with pressure release bushing (A); loosen capnut (N) and adjust nut (P) up or down so its under surface is 1/16 inch (1.6mm) above screw (M) as shown in Fig. 17. Hold nut (P) in position and tighten capnut (N).

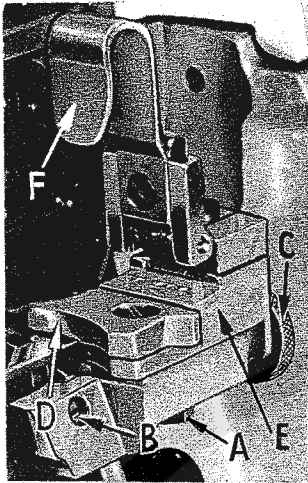

Fig. 18

#### SETTING THE HEMMING GUIDE SUPPORT BRACKET (STYLES 395-20 and -21)

Loosen lock screw (A, Fig. 18), then proceed as follows:

Assemble the hemming guide support bracket onto the lower knife support bracket by means of screw (B, Fig. 18). With the knurled adjusting screw (C), set the edge guide (D) so that the left side of its tip is even with and parallel to the right side of the right feed slot in the throat plate.

When the edge guide tip is in this position, the front or leading edge should be slightly to the right of parallel. This adjustment can be made by positioning the stop screw (A, Fig. 19) located towards the front of the hinge block and edge guide support bracket (E, Fig. 18).

Under normal conditions, the edge guide is spring loaded to compensate for the differences in the material thickness. The amount of movement and the pressure applied to the edge guide tip can be set by removing lock screw (B, Fig. 19) and adjusting the screw which presses against the spring and pin, located in the hinge block and edge guide support bracket (E, Fig. 18). Replace lock screw and tighten securely.

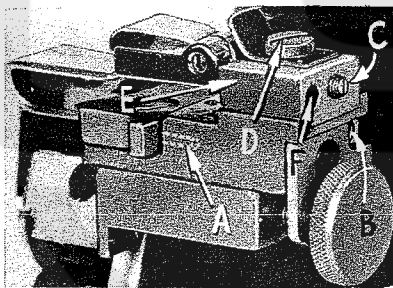

Fig. 19

If movement of the edge guide is not required, then remove lock screw (B, Fig. 19), set screw and spring; then replace set screw and lock screw. Be sure set screw is tightened against pin and lock screw is tightened against set screw.

#### FINAL ADJUSTMENT OF HEMMING GUIDE (STYLES 395-20 and -21)

Adjust the edge guide (D, Fig. 18) by turning the knurled adjusting screw (C) so that the stitches are located in the folded edge, yet do not show on the face of the fabric. At this point re-tighten screw (A, Fig. 18) securely.

Adjust the overhanging guide (F, Fig. 18) so that the space between its guiding edge and the edge guide (D) corresponds with the thickness of the material to be hemmed. Loosen set screw (C, Fig. 19) and holding screw (D), now move the hinge block (E) to obtain the proper distance between the edge guide and the overhanging guide. Re-tighten screws (C) and (D). Remove lock screw (F) and adjust stop screw that is in front of lock screw, so that the tip of the overhanging guide is located at the center of the edge guide vertically. Replace lock screw (F) and tighten against stop screw.

#### SETTING STITCH LENGTH

The actual stitch length produced is usually measured as the number of stitches sewn per inch of seam. This is determined by the distance feeds travel with their teeth protruding above the throat plate.

## SETTING STITCH LENGTH (Continued)

Class 395 machines are fitted with a feed system having two separate feed dogs - MAIN (rear) and DIFFERENTIAL (front).

The resulting stitch length is determined to a great extent by travel of the main feed. The differential feed travel can be used to gather or stretch the fabric prior to being stitched.

Length of stitch is determined by the combination of feed eccentrics used. Outer (left) eccentric (A, Fig. 20) actuates main (rear) feed dog; while the inner (right) eccentric (B) actuates the differential (front) feed dog.

In assembling feed eccentrics, be sure hubs are facing each other. Be careful not to damage shaft or key. Tighten nut (C) securely.

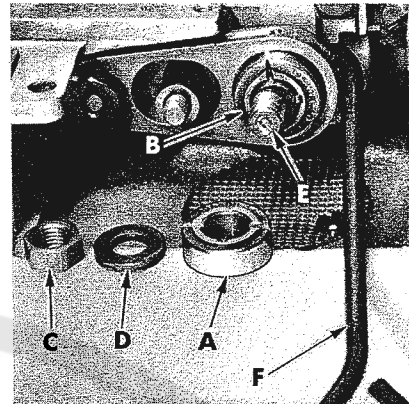

Fig. 20

To change feed eccentrics, remove nut (C) and washer (D) from end of shaft (E). Turn handwheel in operating direction until key slot in eccentric is toward front. Using hooked eccentric extractor (F), supplied with machine, reach behind eccentrics as shown and withdraw eccentrics. It may be necessary to move handwheel back and forth slightly during extraction.

## NEEDLE THREAD CONTROL

Check:

The needle thread is controlled by the needle thread eyelet (A, Fig. 21) and the needle thread cam pull-off (B). The needle thread eyelet is set so the securing screw is centered in the screw slot front to back. Raise or lower the eyelet to have the needle thread barely touch the needle thread cam pull-off when the needle carrier is in its lowest position. Moving the eyelet up and back increases the needle thread in the stitch, moving the eyelet down and forward acts in the reverse.

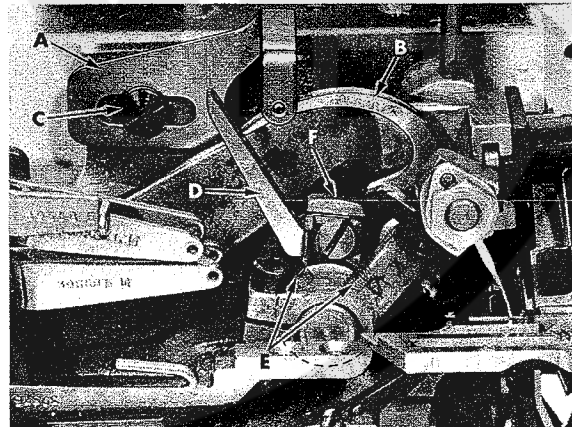

Fig. 21

Procedure:

To adjust needle thread control, loosen screw (C) and position thread eyelet (A) as described in check. Hold eyelet in position and tighten screw (C).

## LOOPER THREAD PULL-OFF

Check:

Clearance between looper thread pull-off (D, Fig. 21) and needle thread cam pull-off (B) should be only enough to ensure proper take-up of looper thread as shown in Fig. 21.

## LOOPER THREAD PULL-OFF (Continued)

### Procedure:

Loosen screws (E) and rotate looper thread pull-off lever (F) front to back on needle driving shaft until proper clearance is obtained. Before tightening screws (E) be sure to take up all end play in needle drive shaft.

## LOOPER THREAD CONTROL

### Check:

When a normal amount of looper thread is drawn, upper and lower looper threads will be a little slack when needle(s) is at highest position (lower looper thread only for Styles 395-20 and -21).

The auxiliary upper looper thread guide (E, Fig. 22) should be centered in its adjusting slot and set slightly above a horizontal position.

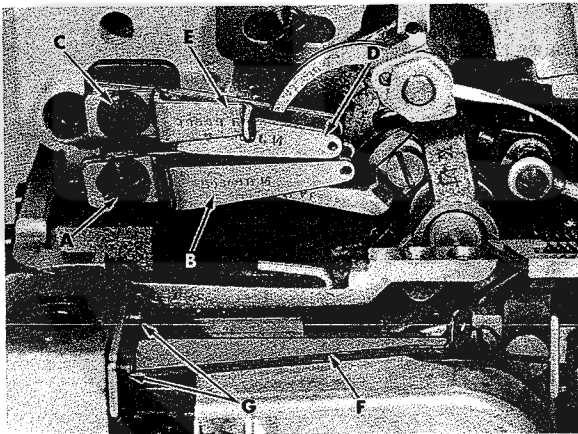

Fig. 22

### Procedure:

Loosen screw (A, Fig. 22). Center lower looper thread eyelet (B) in its adjusting slot and set eyelet in a horizontal position. Hold eyelet (B) in position and tighten screw (A).

On all Styles except 395-20 and -21; loosen screw (C). Center upper looper thread eyelet (D) in its adjusting slot and set eyelet so it rests on the top surface of lower looper thread eyelet and back of lower looper thread eyelet.

Center auxiliary upper looper thread guide (E) in its adjusting slot and set guide so it is slightly above a horizontal position. Hold

lower looper thread eyelet (D) and auxiliary upper looper thread guide (E) in position and tighten screw (C).

To set frame lower looper thread guide (F) loosen screw (G) and move lower looper to its extreme left end of travel and position the guide so the looper thread is held in a straight line to the lower looper. Tighten screw (G).

**NOTE:** Moving eyelets (B and D) to the rear increases the amount of looper thread in the system and moving them forward reduces the amount of thread in the system.

## POSITIONING THE PURL

The following instructions are for machines producing three thread stitch type 504.

If the needle thread loop is NOT being set properly as shown in Fig. 23, excessive seam grinning would result. Thread control adjustments which should be checked to correct this condition include:

- Lower looper thread tension too tight.
- Needle thread eyelet too high.
- Lower looper thread eyelet too far forward.
- Needle thread tension too loose.

If the purl is NOT being formed on the edge of the fabric as shown in Fig. 24, an unbalance between the looper threads is indicated, and improper coverage of the seamed edge would occur. If the purl is being pulled under the edge, check the following thread control adjustments:

- Lower looper thread too tight.
- Lower looper thread eyelet too far forward.
- Upper looper thread eyelet too far to the rear.
- Upper looper thread tension too loose.

If the purl is being pulled over the edge as shown in Fig. 25, check the following thread control adjustments:

- Upper looper thread tension too tight.
- Upper looper thread eyelet too far forward.
- Lower looper thread eyelet too far to the rear.
- Lower looper thread tension too loose.

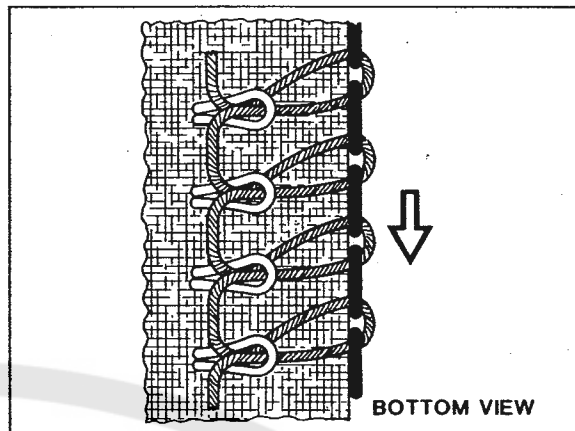

Fig. 23

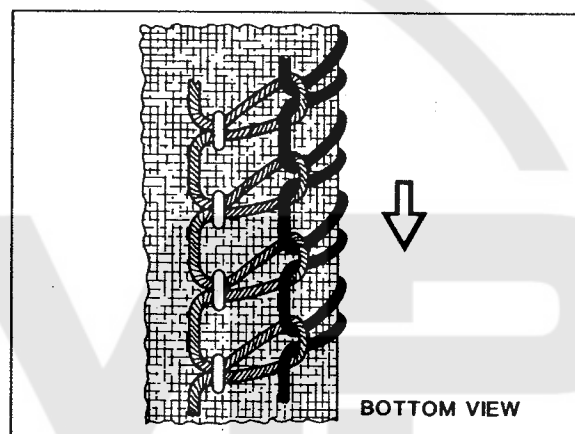

Fig. 24

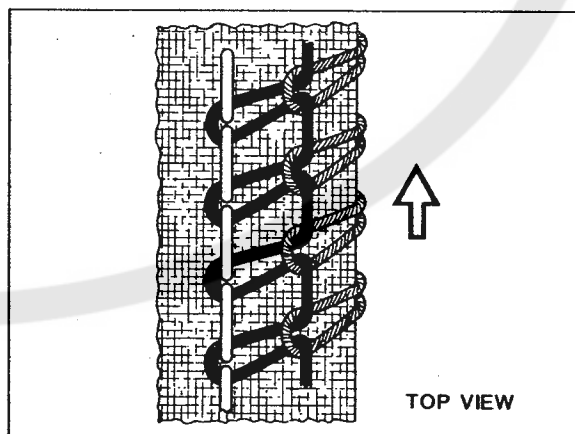

Fig. 25

## THREAD TENSIONS

Thread tension is regulated by the tension assemblies. Turning tension nuts clockwise increases tension applied to thread, counterclockwise reduces tension. Normally, tension on the threads should be only enough to produce a balanced stitch.

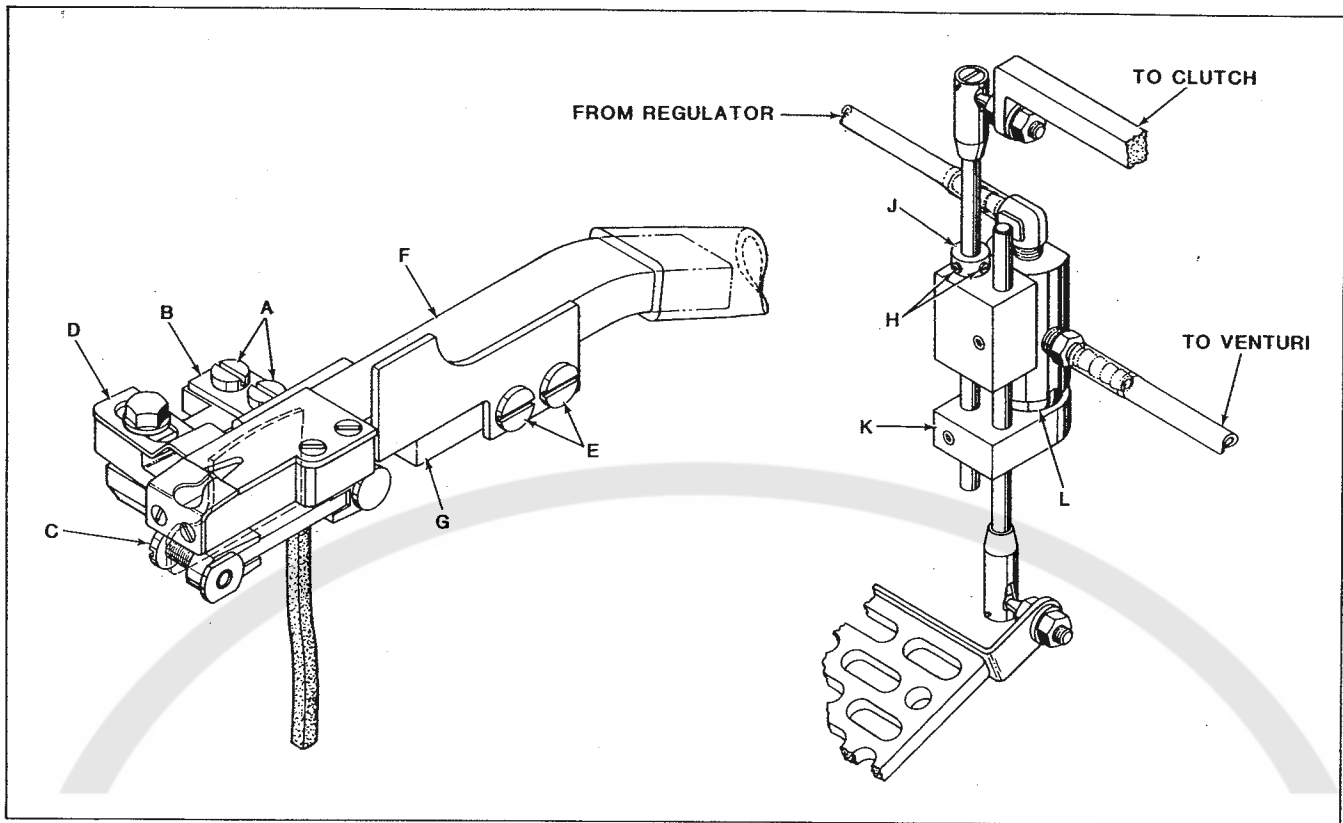

Fig. 26

"AIR-KLIPP" VACUUM CHAIN CUTTER

1. If adjustment to the "AIR-KLIPP" is necessary; remove cloth plate and throat plate.
2. Remove "AIR-KLIPP" assembly from the machine by removing screws (A, Fig. 26), washer plate (B) and screw (C).

With "AIR-KLIPP" assembly out of machine; position movable knife (D) to its extreme right. Loosen screws (E) and press air tube (F) and base (G) together applying only enough pressure on movable knife to ensure proper cutting maintaining a slight shear angle, then tighten screws (E).

When the movable knife (A, Fig. 26A) travels from extreme left to the right; its cutting edge must be even with the cutting edge of stationary knife-Ref. Point B.

To adjust movable knife (A), loosen screw (C) and position knife front to back as required. Hold knife in position and tighten screw (C). Check, if movable knife (A) is adjusted properly it will cut a single strand of thread when manually moving knife left to right.

3. Re-assemble "AIR-KLIPP" assembly to the machine, securing knife driving link with screw (C, Fig. 26) and base with washer plate (B) and screws (A).

With "AIR-KLIPP" assembly in position, temporarily replace throat plate and check for a 1/64 inch (.4mm) clearance between front edge of air tube (D, Fig. 26A) and rear edge of throat plate (E), as shown. If a clearance adjustment is necessary, loosen screws (E, Fig. 26) and adjust the air tube (F) front to back on "AIR-KLIPP" base as required. Re-adjust movable knife pressure as outlined in STEP 2, then tighten screws (E).

Before tightening mounting screws be sure the right side of "AIR-KLIPP"® base is set flush against the main feed bar. Tighten screws (A and C).

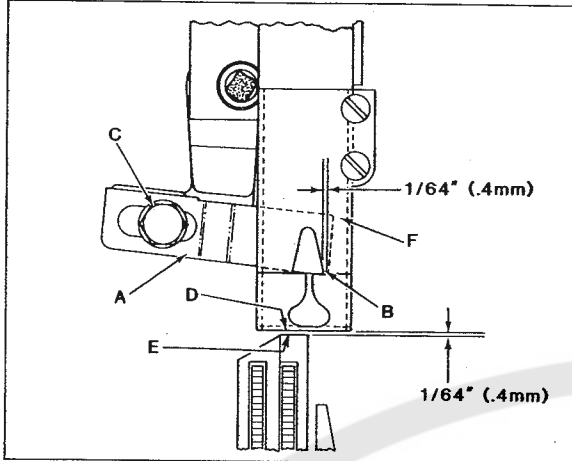

Fig. 26A

NOTE: Main stitch length determines movable knife travel and must be set before making the following adjustment.

With main stitch length set and movable knife (A, Fig. 26A) positioned to its extreme right; loosen screw (C) and adjust movable knife left to right as required to extend no less than 1/64 inch, (.4mm) beyond the cutting edge of stationary knife as in Fig. 26A. Clearance must be maintained between the moving knife and the inner wall of air tube - Ref. Point F. Hold knife in position and tighten screw (C).

- To adjust the air valve system, loosen screws (H, Fig. 26) and set collar (J) to permit actuator block (K) to just contact button of air valve - Ref. Point L, when button is fully extended, then tighten screws (H). When treadle is pressed to start sewing, the air valve must open before the clutch is engaged.

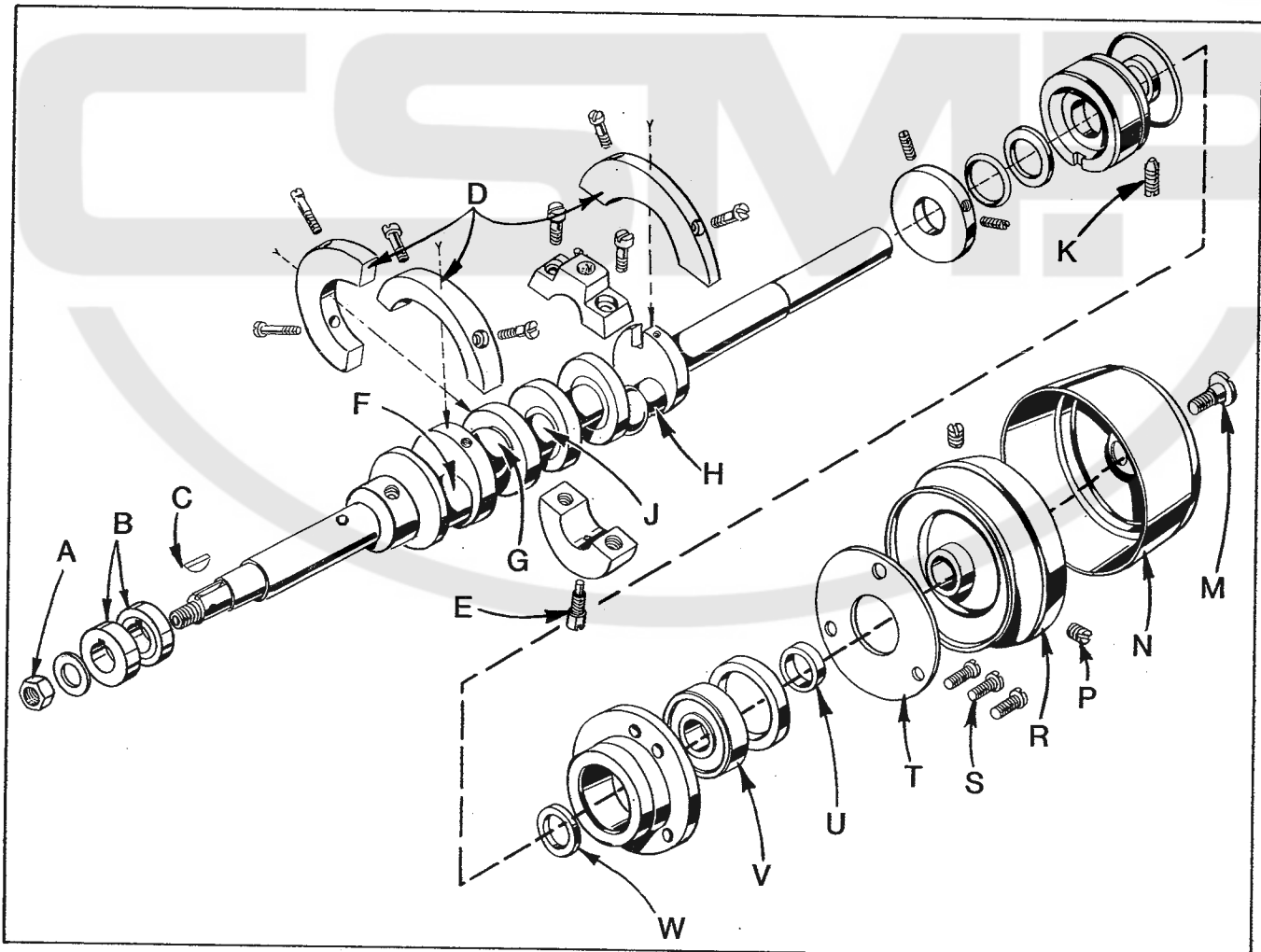

Fig. 27

## TO REMOVE CRANKSHAFT

Crankshaft can be withdrawn easier if these steps are followed:

1. Drain oil by removing plug screw located on back of machine near bottom edge of base.
2. Remove top and bottom covers of machine.
3. Remove feed eccentric nut (A, Fig. 27) and remove eccentrics (B).
4. Remove key (C).
5. Remove three counterweights (D). Identify these counterweights so that they will be re-assembled in the proper places.
6. Remove screw (E) which holds crankshaft split bearing. This screw is reached through bottom of bed casting.
7. Remove caps of bearings on crankshaft at points F, G and H. When re-assembling bearing caps make sure they are in their original position. Trademarks are stamped on both halves of the caps and both trademarks should be on the same side of the bearings. Also, screws should be re-assembled in the same holes from which they were removed.
8. Loosen clamp nut (A, Fig. 28) which holds upper knife driving arm (B). Access to clamp nut is through top cover. Draw driving arm to the left until upper knife driving lever (C) and connecting rod (D) drop, allowing removal of bearing cap (E). This is located at bearing point (J, Fig. 27) on crankshaft. Observe same precautions while re-assembling cap as described in Step 7 above.
9. Remove screw (K, Fig. 27) which holds inner right crankshaft bearing. This screw is reached through bottom of bed casting.
10. Remove screw (M); take off pulley cap (N).
11. Loosen two screws (P); remove pulley (R).
12. Remove three screws (S); take off bearing retaining plate (T); also, spacer collar (U) may be removed at this time.
13. Crankshaft may now be removed.
14. If necessary to replace ball bearing (V), it should be pressed off shaft on an arbor press. In replacing bearing it must be pressed on carefully until it seats against ground thrust washer (W).
15. Carefully observing reverse of the foregoing operations should simplify re-assembly of crankshaft. Checking exploded view drawings for location of various parts and constant testing for binds during re-assembly will also prove helpful.

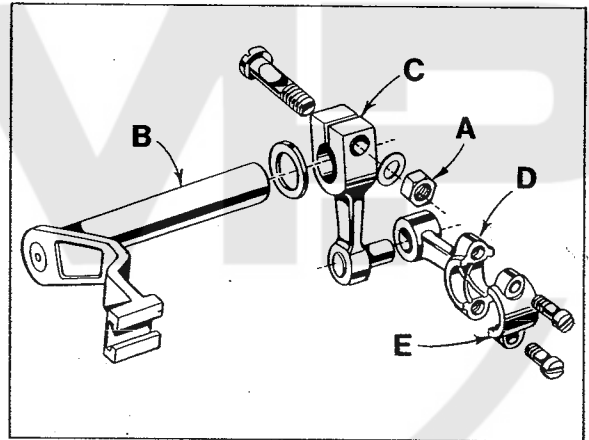

Fig. 28



## TO REMOVE CRANKSHAFT (Continued)

16. Before re-assembling, thoroughly clean and dry top and bottom covers and gaskets. Before re-assembling bottom cover make sure that spring pressed oil wick which lubricates left crankshaft bearing is inserted in hole in casting and that it contacts shaft. The wick stands vertically on its spring against bottom cover. Coat oil drain plug with a sealing compound before re-assembling to prevent oil leakage.

### ORDERING REPAIR PARTS

#### ILLUSTRATIONS

This catalog has been arranged to simplify ordering repair parts. Exploded views of various sections of the mechanism are shown so that the parts may be seen in their actual position in the machine. On the page opposite the illustration is a listing of the parts with their part number, description and number of pieces required in the particular view being shown.

Numbers in the first column are reference numbers only, and merely indicate the position of that part in the illustration. Reference numbers should never be used in ordering parts. Always use the part number which is listed in the second column.

Component parts of sub-assemblies which can be furnished for repairs are indicated by indenting the descriptions under the description of the main sub-assembly.

Example:

43	29126 DF	Looper Bar Driving Lever and Connecting Rod Assembly, lower ---	1
44	39544 N	Connecting Rod -----	1
45	22729 E	Screw -----	2
46	22729 D	Screw -----	2
47	97	Screw -----	2
48	39544 S	Fork, guide -----	1
49	39544 U	Lever -----	1

At the back of the book is a numerical index of all the parts shown in this book. This will facilitate locating the illustration and description when only the part number is known.

#### IDENTIFYING PARTS

Where the construction permits, each part is stamped with the part number. Part numbers represent the same part, regardless of catalog in which they appear.

#### TERMS

Prices are net cash and subject to change without notice. All shipments are forwarded f.o.b. shipping point. Parcel Post shipments are insured unless otherwise directed. A charge is made to cover postage and insurance.

#### TORQUE REQUIREMENT

Torque specifications given in this catalog are measured in inch-pounds or centimeter/kilograms. All straps and eccentrics must be tightened to 19-21 in. lbs. (22-24 cm/kg) unless otherwise noted. All nuts, bolts, screws, etc., without torque specifications must be secured as tightly as possible, unless otherwise noted. Special torque specifications for connecting rods, links, screws, etc., are shown on parts illustrations.

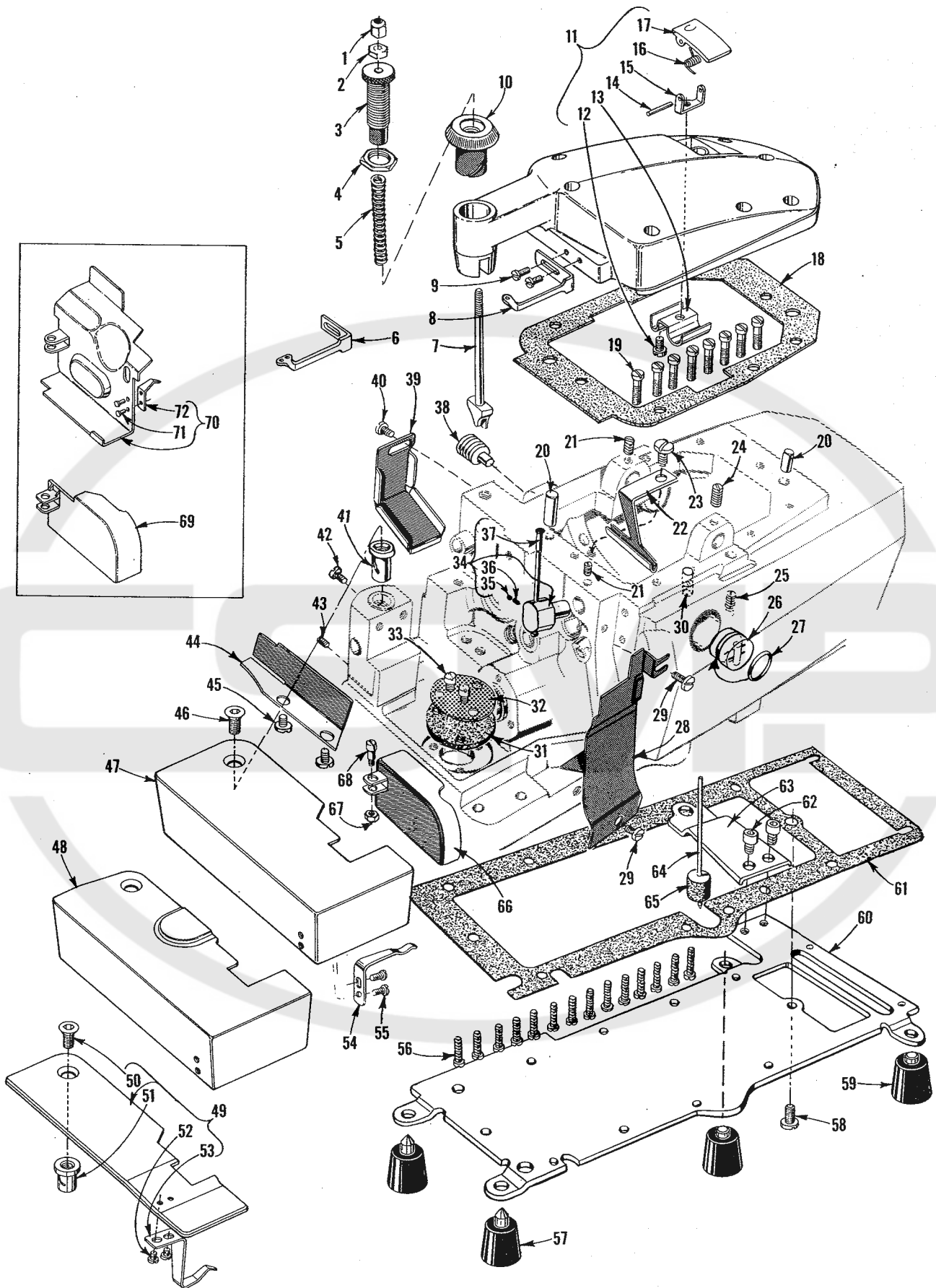

MAIN FRAME, MISCELLANEOUS COVERS AND PLATES

<u>Ref. No.</u>	<u>Part No.</u>	<u>Description</u>	<u>Amt. Req.</u>
1	39557 B	Nut, cap, presser spring plunger -----	1
2	39557 E	Nut, locking -----	1
3	39557 C	Screw, adjusting -----	1
4	39557 F	Nut, lock, adjusting screw -----	1
5	39557	Spring, presser -----	1
6	39563 W	Eyelet, top cover needle thread, Styles -22, -23 -----	1
7	39557 A	Plunger, presser spring -----	1
8	39563 F	Eyelet, top cover needle thread, all Styles except -22, -23 -----	1
9	22569 B	Screw -----	2
10	39556 A	Bushing, presser foot release -----	1
11	39582 EJ	Cover, top, all Styles except -22, -23 -----	1
-	39582 EK	Cover, top, Styles -22, -23 -----	1
12	22562 A	Screw -----	1
13	39582 W	Guard, oil -----	1
14	51-103 Blk.	Pin, hinge -----	1
15	39582 AG	Bracket, hinge -----	1
16	39582 V	Spring -----	1
17	39582 L	Cover, oil filler -----	1
18	39582 EL	Gasket, top cover -----	1
19	22541	Screw -----	8
20	667 D-8	Pin, dowel -----	2
21	22565	Screw, set, upper thread tube assembly and upper looper drive lever shaft -----	2
22	39594 R	Plate, oil collector -----	1
23	22569 D	Screw -----	1
24	22565 S	Screw, spot, upper looper drive lever shaft -----	1
25	22894 AE	Screw, lower looper bar driving lever shaft -----	2
26	39593 H	Gauge, oil -----	1
27	660-243	Ring, oil seal -----	1
28	39578 T	Guard, chip, all Styles except -22, -23 -----	1
-	39578 U	Guard, chip, Styles -22, -23 -----	1
29	22569 D	Screw -----	2
30	22569 K	Screw, oil gauge -----	1
31	39594 H	Strainer, oil -----	1
32	39594 G	Screen, oil filter -----	1
33	22569 B	Screw -----	2
34	29477 GW	Thread Tube Assembly, upper looper -----	1
35	22743	Screw, set -----	1
36	39568 J	Spring, tension -----	1
37	39568 G	Tube, thread -----	1
38	22571 E	Screw, oil drain plug -----	1
39	39534 R	Shield, oil, feed bar -----	1
40	90	Screw -----	1
41	39501 K	Stud, cloth plate, all Styles except -20, -21 -----	1
42	22569	Screw, locking, cloth plate stud -----	1
43	22565 F	Screw, locking, feed adjusting pin -----	1
44	39578 F	Guard, cloth plate fabric, Styles -26, -28, -40, -42--	1
45	138	Screw -----	2
46	22657 D-12	Screw, cloth plate, all Styles except -20, -21 -----	1
47 thru 72		See following page	

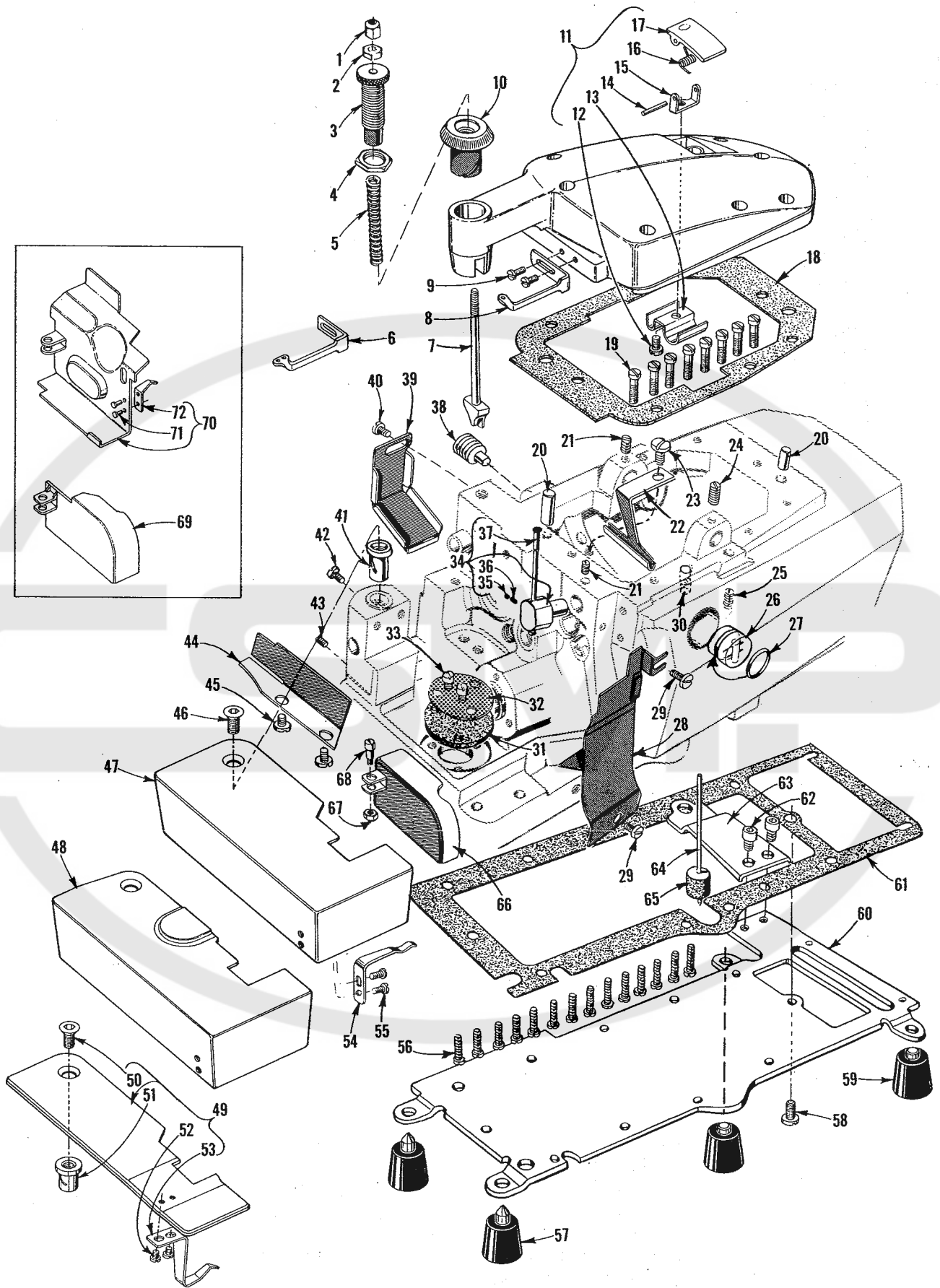

MAIN FRAME, MISCELLANEOUS COVERS AND PLATES

<u>Ref. No.</u>	<u>Part No.</u>	<u>Description</u>	<u>Amt. Req.</u>
1 thru 46		See preceding page	
47	39501 DAG	Cloth Plate, Styles -26, -28, -40, -42 -----	1
-	39501 DC	Cloth Plate, Styles -22, -23 -----	1
48	39501 DAF	Cloth Plate, Styles -26V, -28V, -40V, -42V -----	1
49	39501 AP	Cloth Plate, Styles -20, -21 -----	1
50	22567 D-12	Screw -----	1
51	39501 K	Stud -----	1
52	22513	Screw -----	2
53	39532 D	Spring, latch -----	1
54	39532 A	Spring, cloth plate latch, all Styles except -20, -21-	1
55	90	Screw, latch spring, all Styles except -20, -21 -----	2
56	22541 B	Screw -----	14
57	51295 B	Isolator, all Styles except -22, -23 -----	2
58	22586 T	Screw -----	1
59	39595	Isolator, all Styles except -22, -23 -----	2
-	39595	Isolator, Styles -22, -23 -----	4
60	39582 X	Cover, bottom -----	1
61	39582 Y	Gasket, bottom cover -----	1
62	22653 D-4	Screw -----	2
63	39582 F	Extension, bottom cover -----	1
64	39593 D	Indicator, oil gauge -----	1
65	39593 C	Float, oil gauge -----	1
66	39582 D	Cover, feed mechanism, Styles -26, -28, -40, -42 -----	1
67	41071 G	Nut -----	1
68	86 X	Screw -----	1
69	99679	Cover, feed mechanism, Styles -26V, -28V, -40V, -42V--	1
70	39582 BR	Cover, side, Styles -20, -21 -----	1
-	39582 GG	Cover, side, Styles -22, -23 -----	1
71	39582 J	Rivet -----	2
72	39582 H	Spring -----	1

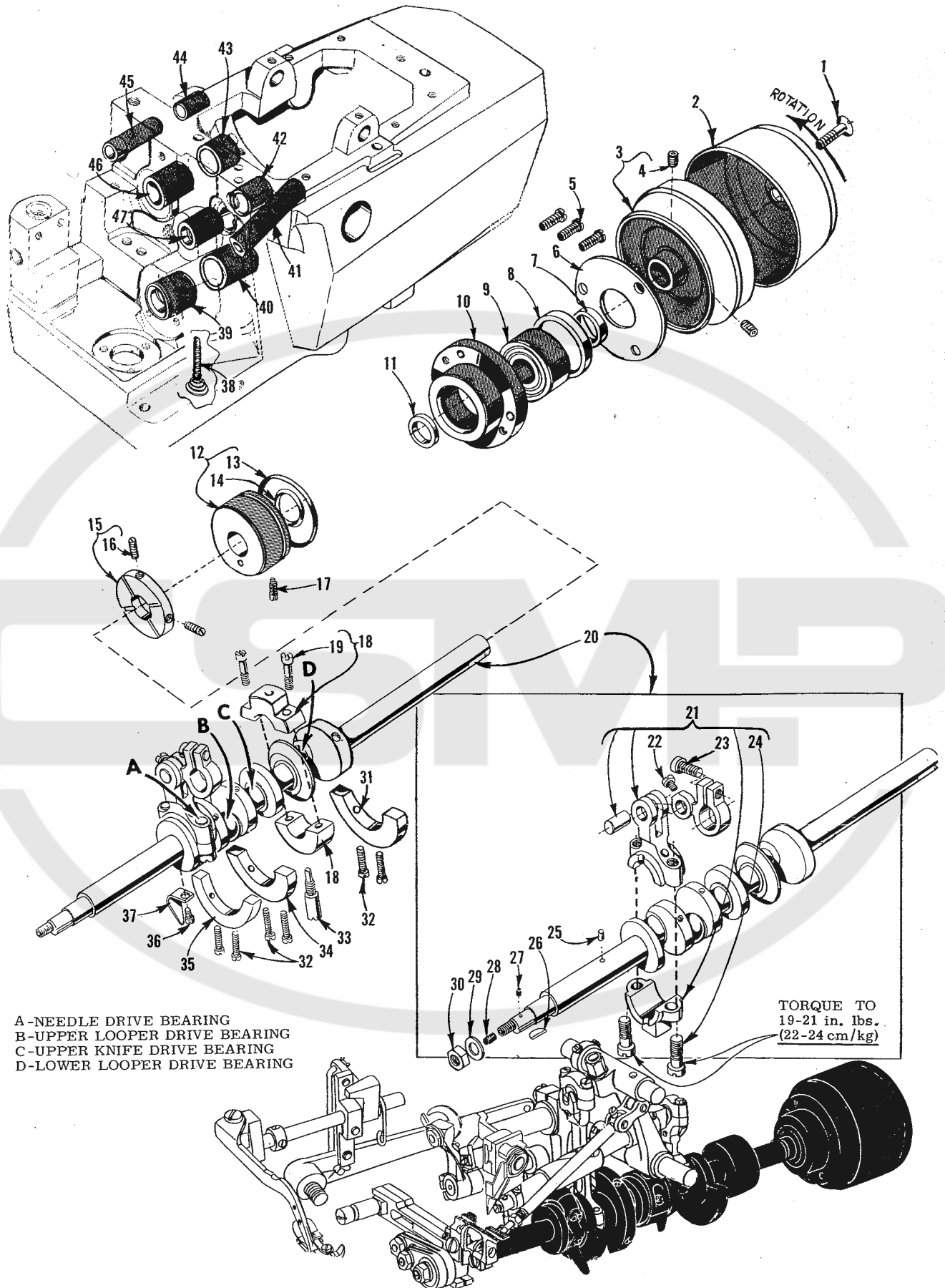

CRANKSHAFT MECHANISM AND BUSHINGS

<u>Ref. No.</u>	<u>Part No.</u>	<u>Description</u>	<u>Amt. Req.</u>
1	22769 B	Screw -----	1
2	39521 DA	Cap, pulley -----	1
3	39521 G	Pulley -----	1
4	22894 C	Screw -----	2
5	22569 B	Screw -----	3
6	39590 H	Plate, retaining, crankshaft ball bearing -----	1
7	39590 S	Collar, spacing -----	1
8	39590 R	Collar, stop, ball bearing -----	1
9	660-268	Bearing, ball -----	1
10	39590 G	Housing, bearing -----	1
11	39590 J	Washer, thrust -----	1
12	39590 X	Bearing, crankshaft (intermediate) -----	1
13	660-443	"0" Ring -----	1
14	660-204	"0" Ring -----	1
15	39590 P	Collar, oil slinger -----	1
16	77 Q	Screw, set -----	2
17	22565 F	Screw -----	1
18	39590 D	Bearing, split -----	1
19	97 A	Screw -----	2
20	29477 JM	Crankshaft and Needle Driving Arm Crank Assembly, Styles -20, -21, -40, -40V, -42, -42 V -----	1
-	29477 KE	Crankshaft and Needle Driving Arm Crank Assembly, Styles -22, -23, -26, -26V, -28, -28V -----	1
21	29477 MC	Needle Driving Arm Crank and Connecting Rod Assembly -----	1
22	22768 C	Screw, connecting rod pin -----	1
23	22596 H	Screw, driving arm crank -----	1
24	22587 M	Screw, connecting rod -----	2
25	51-228 Btk.	Plug, vent -----	1
26	39541 A	Key, feed driving eccentric -----	1
27	30-106 Btk.	Plug, wood -----	1
28	CO-67 E	Plug, cork -----	1
29	40-46	Washer -----	1
30	258	Nut -----	1
31	39591 B	Counterweight, crankshaft (right) -----	1
32	22747 B	Screw -----	6
33	39590 N	Stud, split bearing -----	1
34	39591 A	Counterweight, crankshaft (intermediate) -----	1
35	39591 K	Counterweight, crankshaft (left) -----	1
36	87 U	Screw -----	1
37	39594 N	Splasher, oil -----	1
38	666-94	Wick and Spring, oil -----	1
39	39590	Bushing, crankshaft (left) -----	1
40	39590 T	Bushing, crankshaft (intermediate) -----	1
41	39544 X	Bushing, lower looper bar -----	1
42	39552 P	Bushing, needle driving arm crank (right) -----	1
43	39573 AA	Bushing, upper knife driving arm (right) -----	1
44	39555 R	Bushing, foot lifter shaft (right) -----	1
45	39555 P	Bushing, foot lifter shaft (left) -----	1
46	39573 K	Bushing, upper knife driving arm (left) -----	1
47	39552 U	Bushing, needle driving arm crank (left) -----	1

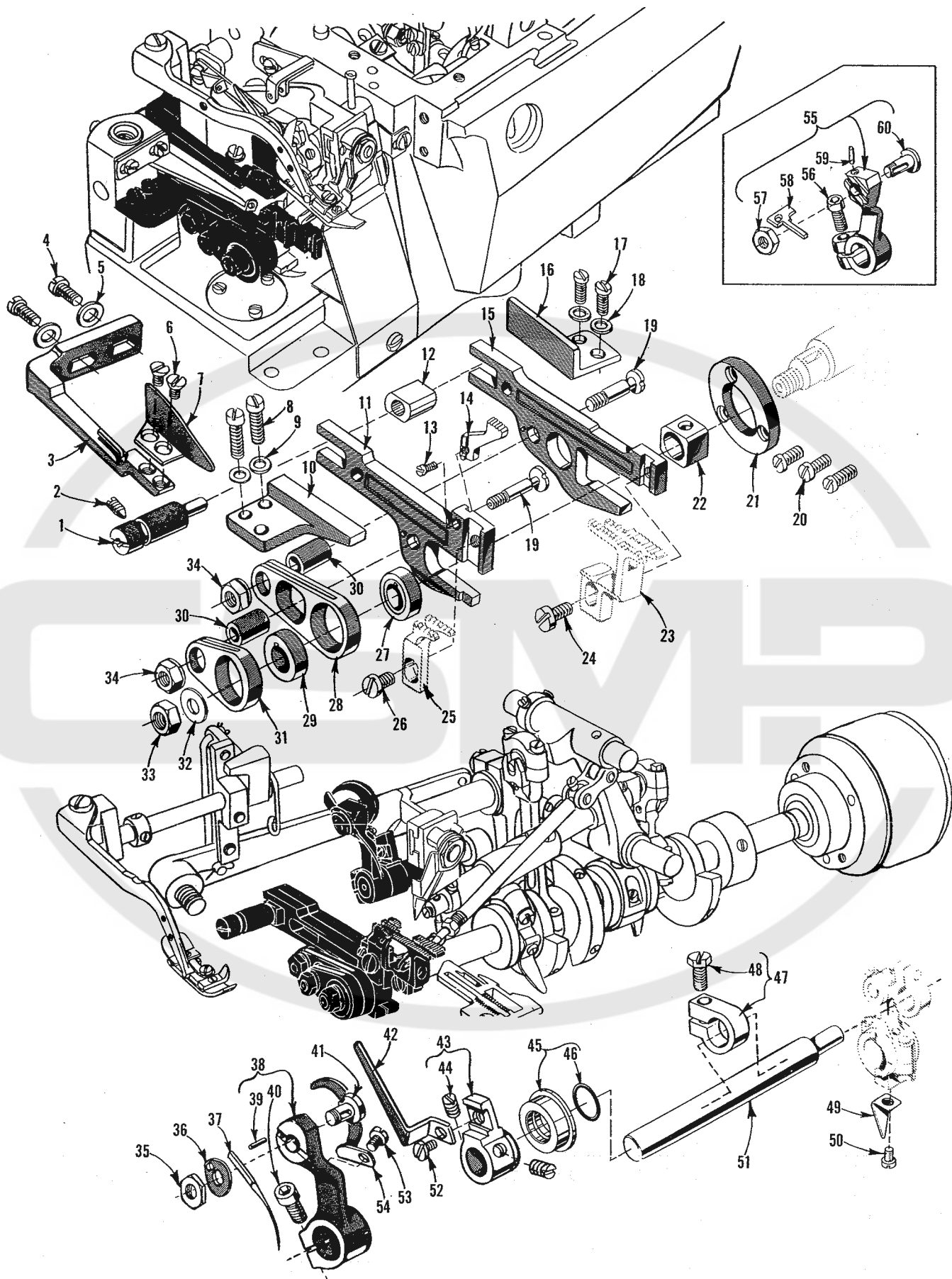



NEEDLE DRIVE AND FEED MECHANISM

<u>Ref.</u> <u>No.</u>	<u>Part</u> <u>No.</u>	<u>Description</u>	<u>Amt.</u> <u>Req.</u>
1	39535 C	Pin, feed adjusting -----	1
2	22565 F	Screw, locking -----	1
3	39578 P	Bracket, fabric guard mounting, all Styles except -26V, -28V, -40V, -42V -----	1
4	22569 B	Screw, all Styles except -26V, -28V, -40V, -42V -----	2
5	8372 A	Washer, all Styles except -26V, -28V, -40V, -42V -----	2
6	87	Screw, all Styles except -26V, -28V, -40V, -42V -----	2
7	39578 R	Guard, fabric, all Styles except -26V, -28V, -40V, -42V -----	1
8	22541 B	Screw -----	2
9	39835 G	Washer -----	2
10	39535	Guide, main feed bar (left) all Styles except -26V, -28V, -40V, -42V ---	1
11	39534	Feed Bar, main -----	1
12	39535 J	Block, feed bar guide -----	1
13	22797 A	Screw, chaining feed dog, Styles -26, -28, -40, -42 -----	1
14		Feed Dog, chaining (See Page 41) -----	1
15	39534 G	Feed Bar, differential -----	1
16	39535 D	Guide, differential feed bar (right) -----	1
17	22569 B	Screw -----	2
18	53634 C	Washer -----	2
19	39536 B	Stud, feed bar driving -----	2
20	22569 G	Screw -----	3
21	39534 H	Washer, thrust, differential feed bar -----	1
22	39538	Block, feed lift -----	1
23		Feed Dog, differential (See Page 41) -----	1
24	22528	Screw, differential feed dog -----	1
25		Feed Dog, main (See Page 41) -----	1
26	93 A	Screw, main feed dog -----	1
27	39540 B-10	Eccentric, differential feed driving, all Styles except -20, -21 -----	1
-	39540 B-8	Eccentric, differential feed driving, Styles -20, -21 -----	1
28	39536 AE	Connection, differential feed bar driving -----	1
29	39540 B-12	Eccentric, main feed driving, all Styles except -20, -21 -----	1
-	39540 B-14	Eccentric, main feed driving, Styles -20, -21 -----	1
30	39536 C	Bushing, feed bar driving stud -----	2
31	39536 AF	Connection, main feed bar driving -----	1
32	40-46	Washer, crankshaft -----	1
33	258	Nut, crankshaft -----	1
34	39536 E	Nut, feed bar driving stud -----	2
35	14077 A	Nut, needle clamp stud, all Styles except -22, -23 -----	1
36	39551 H	Washer, needle clamp, all Styles except -22, -23 -----	1
37	154 GAS	Needle, all Styles except -22, -23 -----	1
-	154 GAS	Needle, Styles -22, -23 -----	2
38	39552 Z	Arm, needle driving, marked "K", all Styles except -22, -23 -----	1
39	39552 AD	Pin, stop -----	1
40	22596 E	Screw -----	1
41	39551 J	Stud, needle clamp, all Styles except -22, -23 -----	1
42	39568 A	Pull-off, looper thread -----	1
43	39568 AC	Lever, looper thread pull-off -----	1
44	88 B	Screw -----	2
45	39552 AG	Seal, oil, needle driving shaft -----	1
46	660-207	Ring, oil seal -----	1
47	39543 Y	Collar, thrust, needle drive shaft -----	1
48	22782 A	Screw -----	1
49	39594 N	Splasher, oil -----	1
50	87 U	Screw -----	1
51	39552 R	Shaft, needle driving -----	1
52	22513	Screw -----	1
53	87 U	Screw -----	1
54	39563 G	Cam Pull-off, needle thread, all Styles except -20, -21 -----	1
-	39563 J	Cam Pull-off, needle thread, Styles -20, -21 -----	1
55	39552 AC	Arm, needle driving, marked "N", Styles -22, -23 -----	1
56	22596 E	Screw -----	1
57	14077 A	Nut, needle clamp stud -----	1
58	39551 G	Spacer, needle -----	1
59	61351 K-625	Pin, stop -----	1
60	39551 J	Stud, needle clamp -----	1

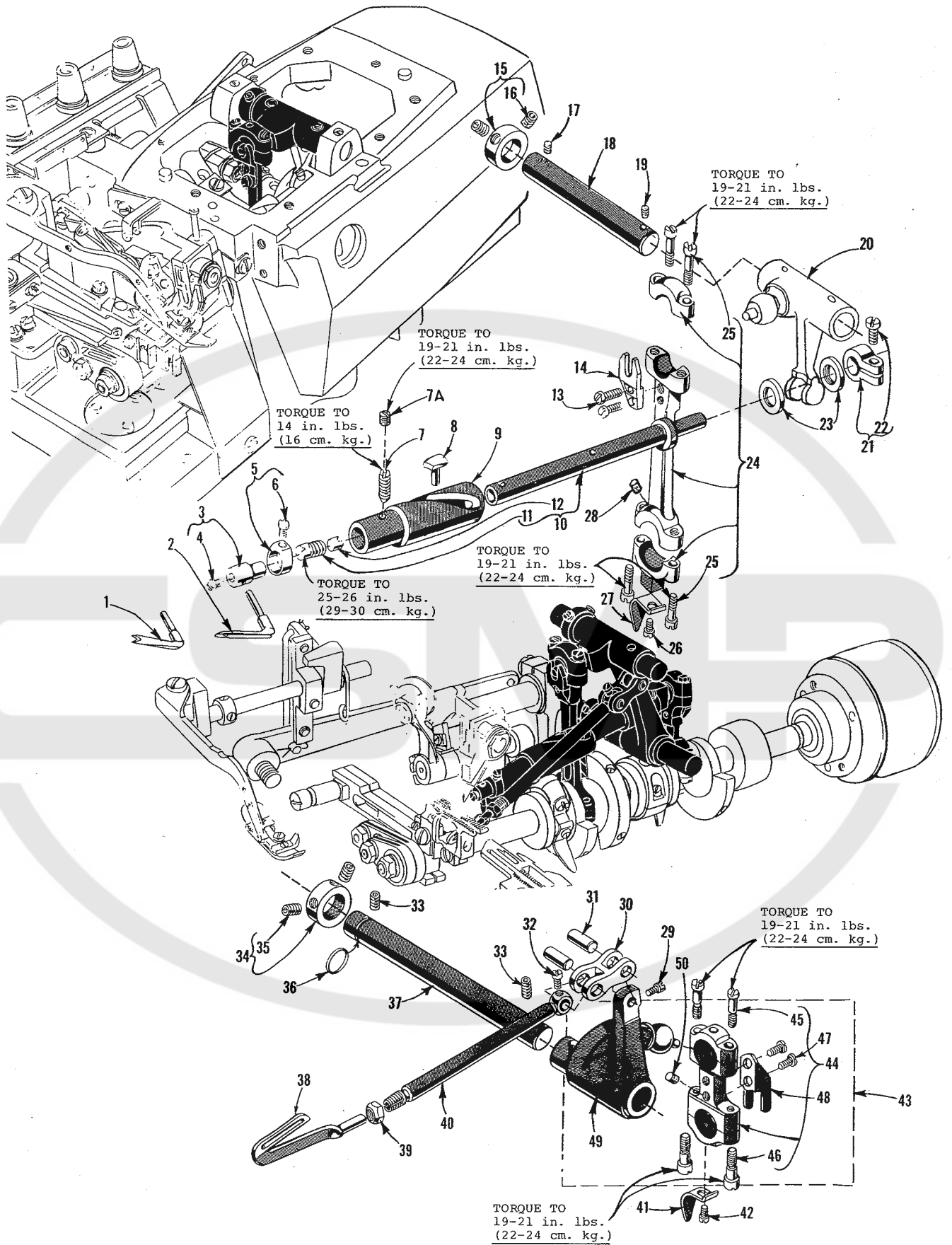

UPPER AND LOWER LOOPER/SPREADER DRIVING PARTS

Ref. No.	Part No.	Description	Amt. Req.
1	39560 A	Spreader, upper, Styles -20, -21 -----	1
2	39508 A	Looper, upper, marked "CC", all Styles except -20, -21 ----	1
3	39543	Holder, upper looper/spreader -----	1
4	22564 G	Screw -----	1
5	39543 A	Collar, upper looper/spreader holder -----	1
6	77	Screw -----	1
7	22565 H	Screw, spot, bushing and cam guide -----	1
7A	1025 L	Screw, locking -----	1
* 8	39543 T	Follower, cam -----	1
* 9	39543 S	Bushing and Cam Guide -----	1
*10	39543 K	Shaft, upper looper/spreader drive -----	1
11	22503 F	Screw, cam follower locking clamp -----	1
12	39543 E	Clamp, cam follower locking -----	1
13	97	Screw -----	2
14	39544 J	Fork, ball joint guide -----	1
15	482 C	Collar, upper looper/spreader shaft -----	1
16	22894 C	Screw, set -----	2
17	22565	Screw, set -----	1
18	39543 X	Shaft, upper looper/spreader drive lever -----	1
19	22565 S	Screw, spot -----	1
20	39543 W	Lever, upper looper/spreader drive -----	1
21	39543 M	Collar, clamp -----	1
22	22562 A	Screw -----	1
23	39543 P	Washer, thrust -----	2
24	39543 U	Connecting Rod -----	1
25	22729 D	Screw -----	4
26	87 U	Screw -----	1
27	39594 N	Splasher, oil -----	1
28	666-255	Felt, connecting rod -----	1
29	77	Screw -----	1
30	39544 B	Link, lower looper bar connecting -----	1
31	39544 D	Pin, connecting link -----	2
32	77	Screw -----	1
33	22894 AE	Screw, set -----	2
34	482 C	Collar, lower looper driving shaft -----	1
35	22894 C	Screw, set -----	2
36	660-206	"O" Ring -----	1
37	39544 V	Shaft, lower looper driving -----	1
38	39508 B	Looper, lower -----	1
39	39151	Nut -----	1
40	39544	Bar, lower looper -----	1
41	39594 N	Splasher, oil -----	1
42	87 U	Screw -----	1
43	29126 DF	Looper Bar Driving Lever and Connecting Rod Assembly, lower -----	1
44	39544 N	Connecting Rod -----	1
45	22729 E	Screw -----	2
46	22729 D	Screw -----	2
47	97	Screw -----	2
48	39544 S	Fork, guide -----	1
49	39544 U	Lever -----	1
50	666-255	Felt -----	1

\* Assembly No. 29126 EC is recommended for replacement instead of individual parts.

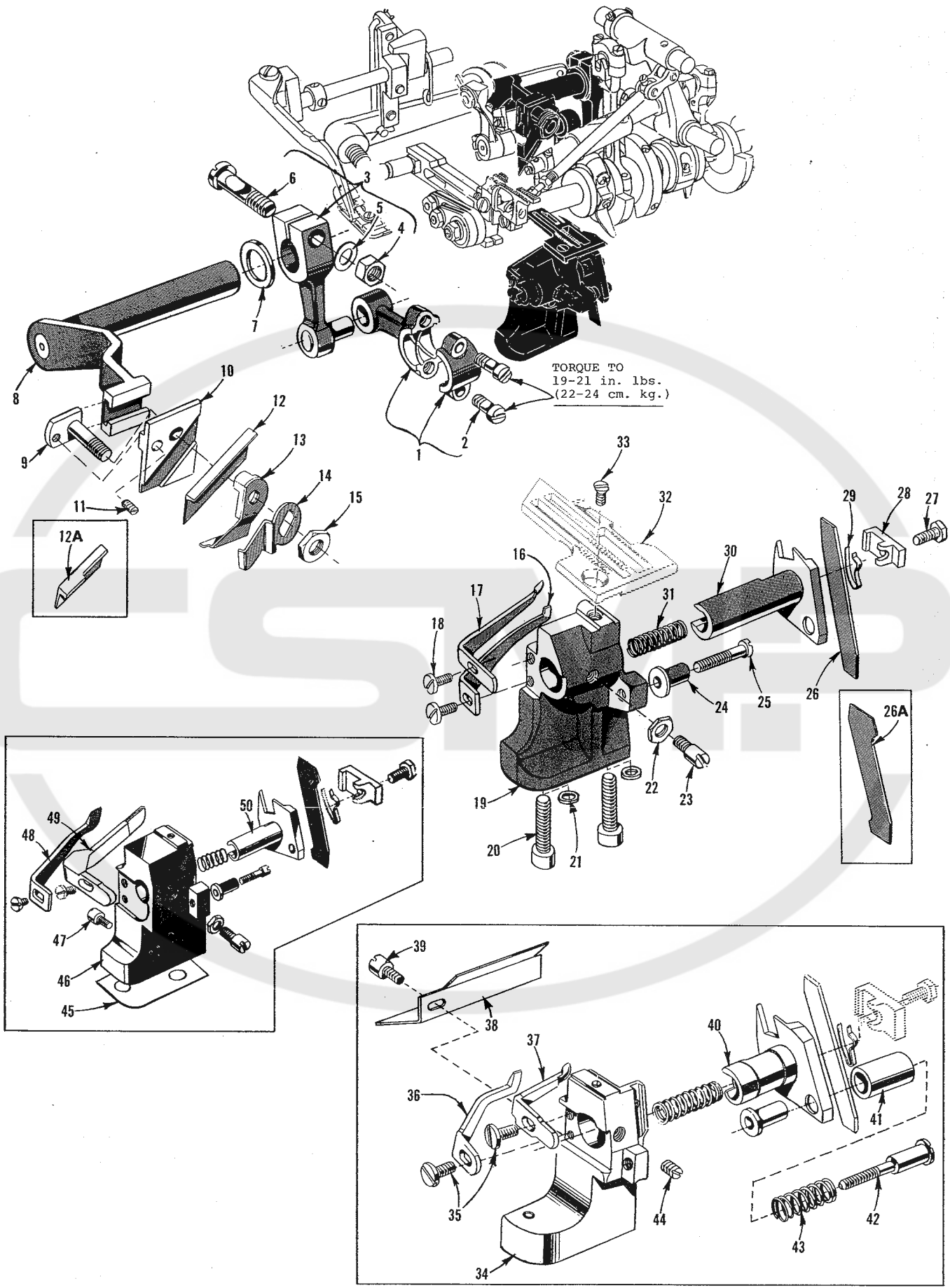

UPPER AND LOWER KNIFE MECHANISM

<u>Ref. No.</u>	<u>Part No.</u>	<u>Description</u>	<u>Amt. Req.</u>
1	39573 J	Connecting Rod, upper knife driving -----	1
2	22587 J	Screw -----	2
3	39573 E	Lever, upper knife driving -----	1
4	55235 E	Nut -----	1
5	6042 A	Washer -----	1
6	55235 D	Stud, locking -----	1
7	39573 A	Washer, upper knife driving arm -----	1
8	39573 H	Arm, upper knife driving -----	1
9	39571 D	Stud, clamp -----	1
10	39572	Block, upper knife holder -----	1
11	22738	Screw, clamp stud -----	1
12	39570	Knife, upper, all Styles except -22, -23 -----	1
12A	39570 J	Knife, upper, Styles -22, -23 -----	1
13	39571 F	Clamp, upper knife -----	1
14	39571 B	Guard, chain -----	1
15	14077	Nut, clamp stud -----	1
16	39525 R	Guard, needle, front, all Styles except -20, -21, -22, -23 ---	1
17	39525 A	Guard, needle, rear, all Styles except -20, -21, -22, -23 ----	1
18	22585 A	Screw, needle guard, all Styles except -20, -21 -----	2
19	39580 A	Bracket, throat plate and lower knife support, all Styles except -20, -21, -22, -23 -----	1
20	22653 B-12	Screw -----	2
21	39580 F	Washer -----	2
22	14077	Nut, locking screw, all Styles except -20, -21 -----	1
23	22892 B	Screw, locking, lower knife holder, all Styles except -20, -21 -----	1
24	39550 C	Stud, locating -----	1
25	22729 B	Screw, locating stud, all Syles except -20, -21 -----	1
26	39549	Knife, lower, all Styles except -22, -23 -----	1
26A	39549 J	Knife, lower, Styles -22, -23 -----	1
27	22588 J	Screw, lower knife clamp -----	1
28	39550 Z	Clamp, lower knife -----	1
29	39550 M	Spring, lower knife clamp -----	1
30	39550 S	Holder, lower knife, all Styles except -20, -21, -22, -23 ----	1
31	39550 E	Spring, lower knife holder -----	1
32		Throat Plate (See Page 41) -----	1
33	22524	Screw, throat plate -----	1
34	39580 BA	Bracket, throat plate and lower knife support, Styles -20, -21 -----	1
35	90	Screw, needle guard, Styles -20, -21 -----	2
36	39525 D	Guard, needle, front, Styles -20, -21 -----	1
37	39525 E	Guard, needle, rear, Styles -20, -21 -----	1
38	39582 BS	Shield, oil, Styles -20, -21 -----	1
39	22585 G	Screw, oil shield and side cover latch, Styles -20, -21 -----	1
40	39550 T	Holder, lower knife, Styles -20, -21 -----	1
41	39550 K	Cover, spring, Styles -20, -21 -----	1
42	22559 H	Screw, adjusting, Styles -20, -21 -----	1
43	39550 J	Spring, knife pressure equalizing, Styles -20, -21 -----	1
44	88 B	Screw, locking, lower knife holder, Styles -20, -21 -----	1
45	39580 E	Shim, .028 inch (.71mm) thick, Styles -22, -23 -----	1
46	39580 AE	Bracket, throat plate and lower knife support, Styles -22, -23 -----	1
47	22585 G	Screw, side cover latch, Styles -22, -23 -----	1
48	39525 M	Guard, needle, front, Styles -22, -23 -----	1
49	39525 P	Guard, needle, rear, Styles -22, -23 -----	1
50	39550 U	Holder, lower Knife, Styles -22, -23 -----	1

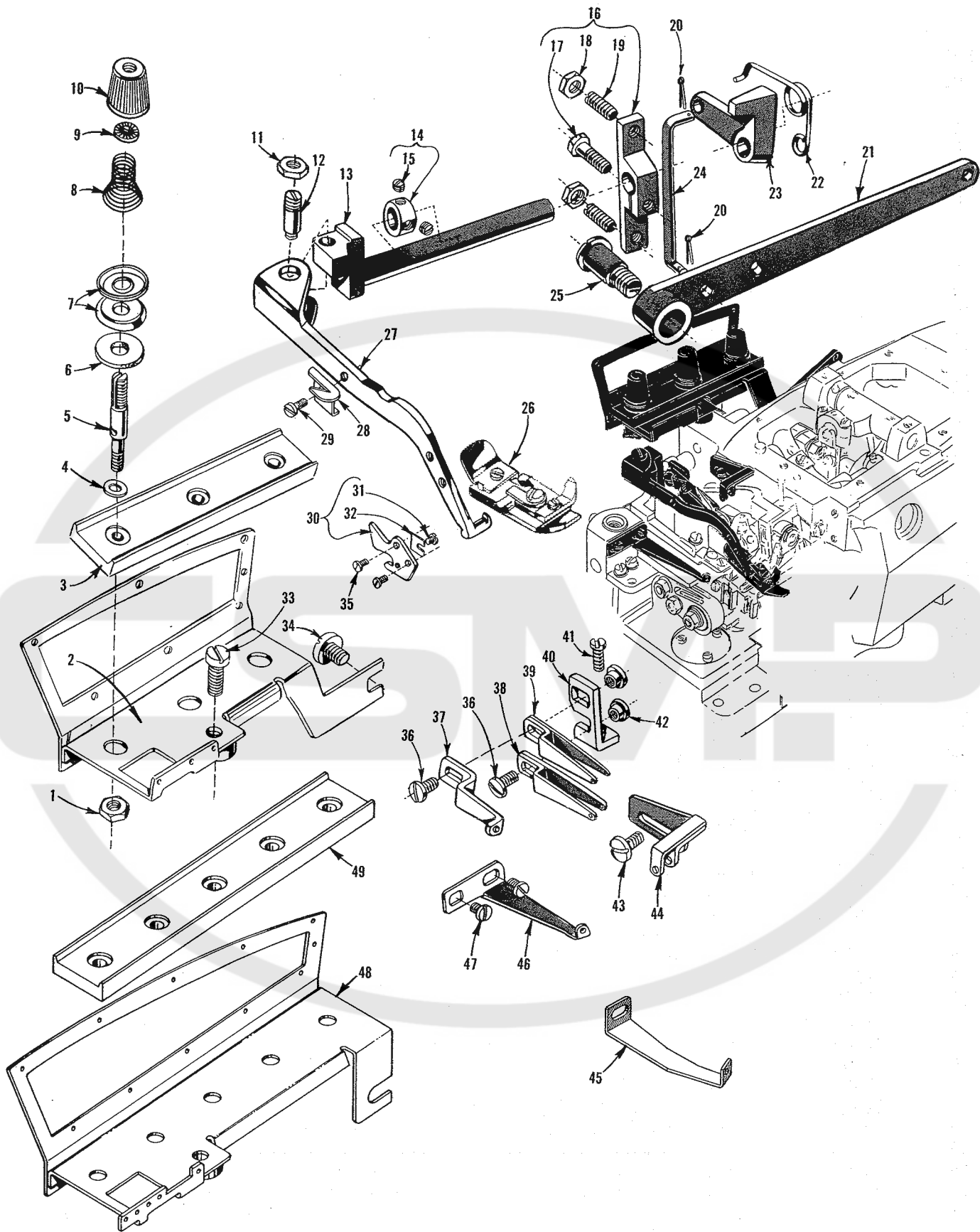

THREAD TENSIONS AND FOOT LIFTER PARTS, MISCELLANEOUS EYELETS

<u>Ref. No.</u>	<u>Part No.</u>	<u>Description</u>	<u>Amt. Req.</u>
1	39592 AH	Nut, tension post, Styles -20, -21 -----	2
-	39592 AH	Nut, tension post, Styles -22, -23 -----	4
-	39592 AH	Nut, tension post, all Styles except -20, -21, -22, -23 -----	3
2	39592 AG-3	Bracket, tension post mounting, all Styles except -22, -23 -----	1
3	39592 AM	Bar, tension post, all Styles except -22, -23 -----	1
4	8372 A	Washer, tension post, Styles -20, -21 -----	2
-	8372 A	Washer, tension post, Styles -22, -23 -----	4
-	8372 A	Washer, tension post, all Styles except -20, -21, -22, -23 -----	3
5	39592 AL	Post, tension, Styles -20, -21 -----	2
-	39592 AL	Post, tension, Styles -22, -23 -----	4
-	39592 AL	Post, tension, all Styles except -20, -21, -22, -23 -----	3
6	39592 AF	Felt, tension disc, Styles -20, -21 -----	2
-	39592 AF	Felt, tension disc, Styles -22, -23 -----	4
-	39592 AF	Felt, tension disc, all Styles except -20, -21, -22, -23 -----	3
7	39592 AD	Disc, tension, Styles -20, -21 -----	4
-	39592 AD	Disc, tension, Styles -22, -23 -----	8
-	39592 AD	Disc, tension, all Styles except -20, -21, -22, -23 -----	6
8	39592 AR-5	Spring, looper tension, Styles -20, -21 -----	1
-	39592 AR-4	Spring, needle tension, Styles -20, -21 -----	1
-	39592 AR-4	Spring, looper tension, Styles -22, -23 -----	2
-	39592 AR-8	Spring, needle tension, Styles -22, -23 -----	2
-	39592 AR-5	Spring, looper tension, all Styles except -20, -21, -22, -23 -----	2
-	39592 AR-8	Spring, needle tension, all Styles except -20, -21, -22, -23 -----	1
9	39592 AK	Ferrule, tension spring, Styles -20, -21 -----	2
-	39592 AK	Ferrule, tension spring, Styles -22, -23 -----	4
-	39592 AK	Ferrule, tension spring, all Styles except -20, -21, -22, -23 -----	3
10	39592 AA	Nut, tension, needle (green), all Styles except left needle on Styles -22, -23 ---	1
-	39592 AC	Nut, tension, lower looper (red) -----	1
-	39592 AB	Nut, tension, upper looper (blue), all Styles except -20, -21 -----	1
-	39592 Z	Nut, tension, (yellow), left needle, Styles -22, -23 -----	1
11	258 A	Nut -----	1
12	22791 H	Pin, screw -----	1
13	39555 A	Shaft, foot lifter lever -----	1
14	12865	Collar, thrust -----	1
15	88	Screw -----	1
16	39555 C	Arm, foot lifter lever -----	2
17	627	Screw -----	1
18	12538	Nut, lock -----	1
19	22597 E	Screw, set -----	2
20	660-142	Pin, cotter -----	2
21	39855	Lever, foot lifter -----	2
22	39555 B	Spring, lifter lever -----	1
23	39555 D	Lever, intermediate -----	1
24	39555 F	Link, lifter lever connecting -----	1
25	22566 B	Screw, lifter lever -----	1
26		Presser Foot (See page 41) -----	1
27	39556 F	Arm, presser -----	1
28	39556 K	Knife, chain cutting, marked "J", Styles -22, -23 -----	1
29	22704	Screw, Styles -22, -23 -----	1
30	39556 M	Knife, chain cutting, Styles -20, -21 -----	1
31	22738 G	Screw -----	1
32	39556 L	Blade -----	1
33	22806 A	Screw -----	1
34	22847 B	Screw -----	1
35	605	Screw, chain cutting knife, Styles -20, -21 -----	1
36	376 A	Screw, all Styles except -20, -21 -----	2
-	376 A	Screw, Styles -20, -21 -----	2
37	39568 E	Eyelet, auxiliary looper thread, all Styles except -20, -21 -----	1
38	39568 B	Eyelet, take-up -----	1
39	39568 L	Eyelet, take-up, all Styles except -20, -21 -----	1
40	39568 D	Bracket, take-up eyelet mounting -----	1
41	22569 B	Screw -----	1
42	43139 A	Nut, all Styles except -20, -21 -----	1
-	43139 A	Nut, Styles -20, -21 -----	2
43	22569 D	Screw -----	1
44	39563 H	Eyelet, needle thread pull-off -----	1
45	99664	Guide, thread, Styles -26V, -28V, -40V, -42V -----	1
46	39568 W	Guide, frame thread, all Styles except -26V, -28V, -40V, -42V -----	1
47	73 X	Screw, all Styles except -26V, -28V, -40V, -42V -----	1
-	73 X	Screw, Styles -26V, -28V, -40V, -42V -----	2
48	39592 AG-5	Bracket, tension post mounting, Styles -22, -23 -----	1
49	39592 AN	Bar, tension post, Styles -22, -23 -----	1

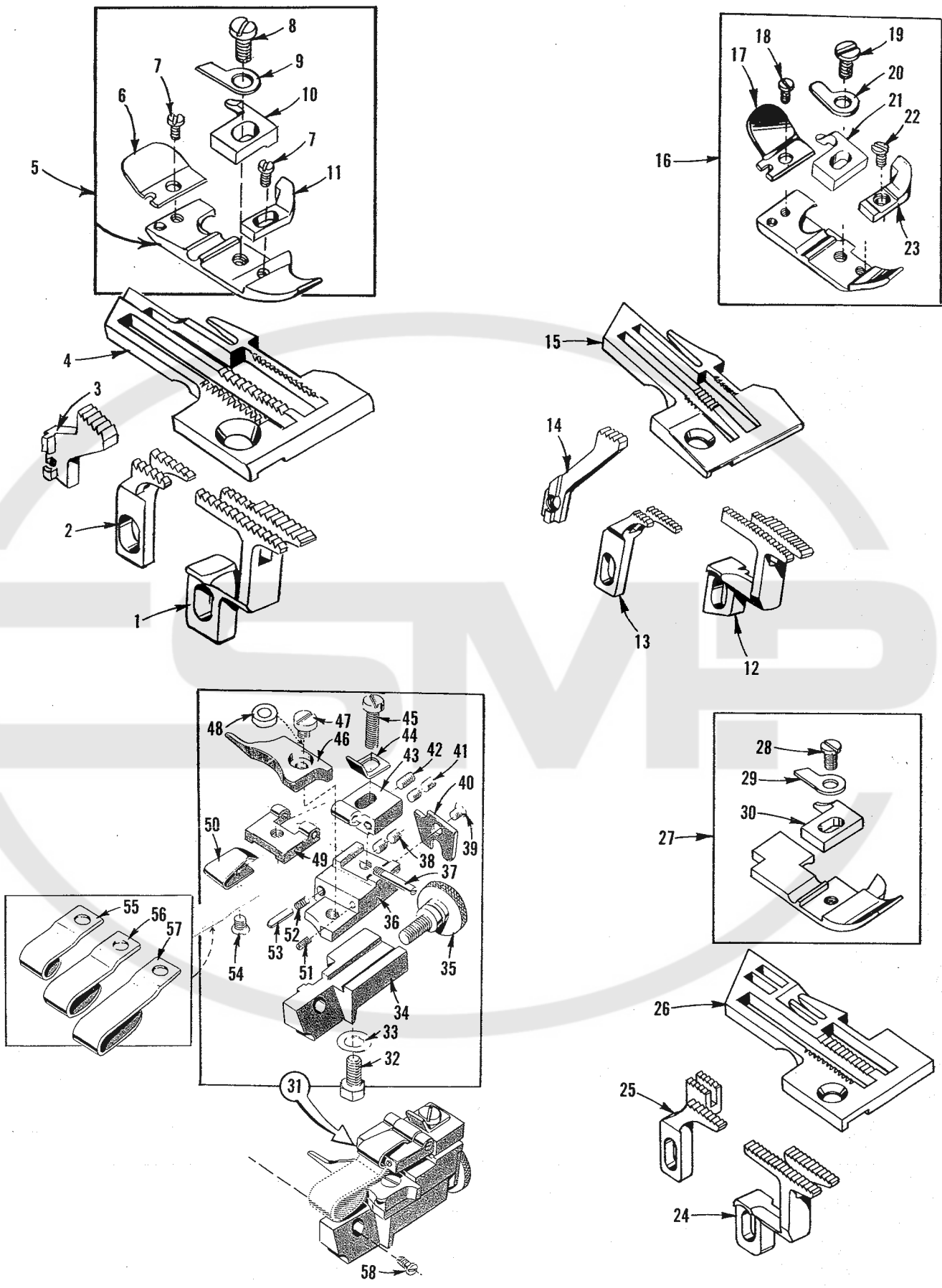



FEED DOGS, THROAT PLATES, PRESSER FEET,  
AND HEMMER GUIDE ASSEMBLY

Ref. No.	Part No.	Description	Amt. Req.
1	39526 B	Feed Dog, differential, 16 t.p.i., all Styles except -20, -21, -22 -23 -----	1
2	39505 B	Feed Dog, main, marked "B", 16 t.p.i., all Styles except -20, -21, -22, -23 -----	1
3	39505 E	Feed Dog, chaining, 20 t.p.i., Styles -26, -28, -40, -42 -----	1
4	39524 B-1/8	Throat Plate, marked "V-1/8", for 1/8 inch (3.8mm) wide seam, all Styles except -20, -21, -22, -23 -----	1
5	39520 A	Presser Foot, all Styles except -20, -21, -22, -23 -----	1
6	39530 C	Shield, chain -----	1
7	22738 B	Screw, chain shield and chip guard -----	2
8	22768 B	Screw, stitch tongue and hinge spring -----	1
9	39530	Spring, hinge -----	1
10	39597 A	Tongue, stitch, marked "DS" -----	1
11	39530 P	Guard, chip -----	1
12	39526 H	Feed Dog, differential, 20 t.p.i., Styles -20, -21 -----	1
13	39505 F	Feed Dog, main, marked "F", 20 t.p.i., Styles -20, -21 -----	1
14	39505 H	Feed Dog, chaining, marked "U", t.p.i., Styles -20, -21 -----	1
15	39524 D	Throat Plate, marked "AM", Styles -20, -21 -----	1
16	39520 H	Presser Foot, Styles -20, -21 -----	1
17	39530 E	Shield, chain -----	1
18	22738	Screw, chain shield -----	1
19	22768 B	Screw, stitch tongue and hinge spring -----	1
20	39530	Spring, hinge -----	1
21	39597 A	Tongue, stitch -----	1
22	22738	Screw, chip guard -----	1
23	39530 B	Guard, chip -----	1
24	39526 W	Feed Dog, differential, marked "AT", 12 t.p.i., Styles -22, -23 -----	1
25	39505 W	Feed Dog, main, marked "W", 12 t.p.i., Styles -22, -23 -----	1
26	39524 W	Throat Plate, marked "AN", Styles -22, -23 -----	1
27	39520 W	Presser Foot, Styles -22, -23 -----	1
28	22768 B	Screw, stitch tongue and hinge spring -----	1
29	39530	Spring, hinge -----	1
30	39597 W	Tongue, stitch, marked "EF" -----	1
31	29481 L	Hemmer Guide Assembly, Styles -20, -21 -----	1
32	303	Screw, edge guide support -----	1
33	61303 D	Washer, cup -----	1
34	39589 AC	Base -----	1
35	22873 C	Screw, adjusting -----	1
36	39589 AD	Support, edge guide -----	1
37	22799 B	Screw, hinge -----	1
38	22743	Screw, edge guide tension spring -----	2
39	222 D	Screw, hemmer guide end plate -----	1
40	39589 AF	Plate, end -----	1
41	HA73 B	Screw, stop -----	2
42	73 C	Screw, set -----	1
43	39589 AB	Block, hinge -----	1
44	39589 AJ	Stop, hemmer guide -----	1
45	22729 A	Screw -----	1
46	39503 L	Guide, edge -----	1
47	22513 C	Screw -----	1
48	39589 AG	Sleeve, edge guide -----	1
49	39589 AA	Block, hinge, overhanging guide -----	1
50	39589 AH	Spring, holding -----	1
51	79077	Screw, stop, edge guide -----	1
52	39568 J	Spring, edge guide tension -----	1
53	39589 AL	Pin, tension spring -----	1
54	222 D	Screw, overhanging guide -----	1
55	39589 AK-1/2	Guide, overhanging, for 1/2 inch (12.7mm) hem, Styles -20, -21 -----	1
56	39589 AK-3/4	Guide, overhanging, for 3/4 inch (19.0mm) hem, Styles -20, -21 -----	1
57	39589 AK-1	Guide, overhanging, for 1 inch (25.4mm) hem, Styles -20, -21 -----	1
58	22593	Screw, hemming guide assembly -----	1

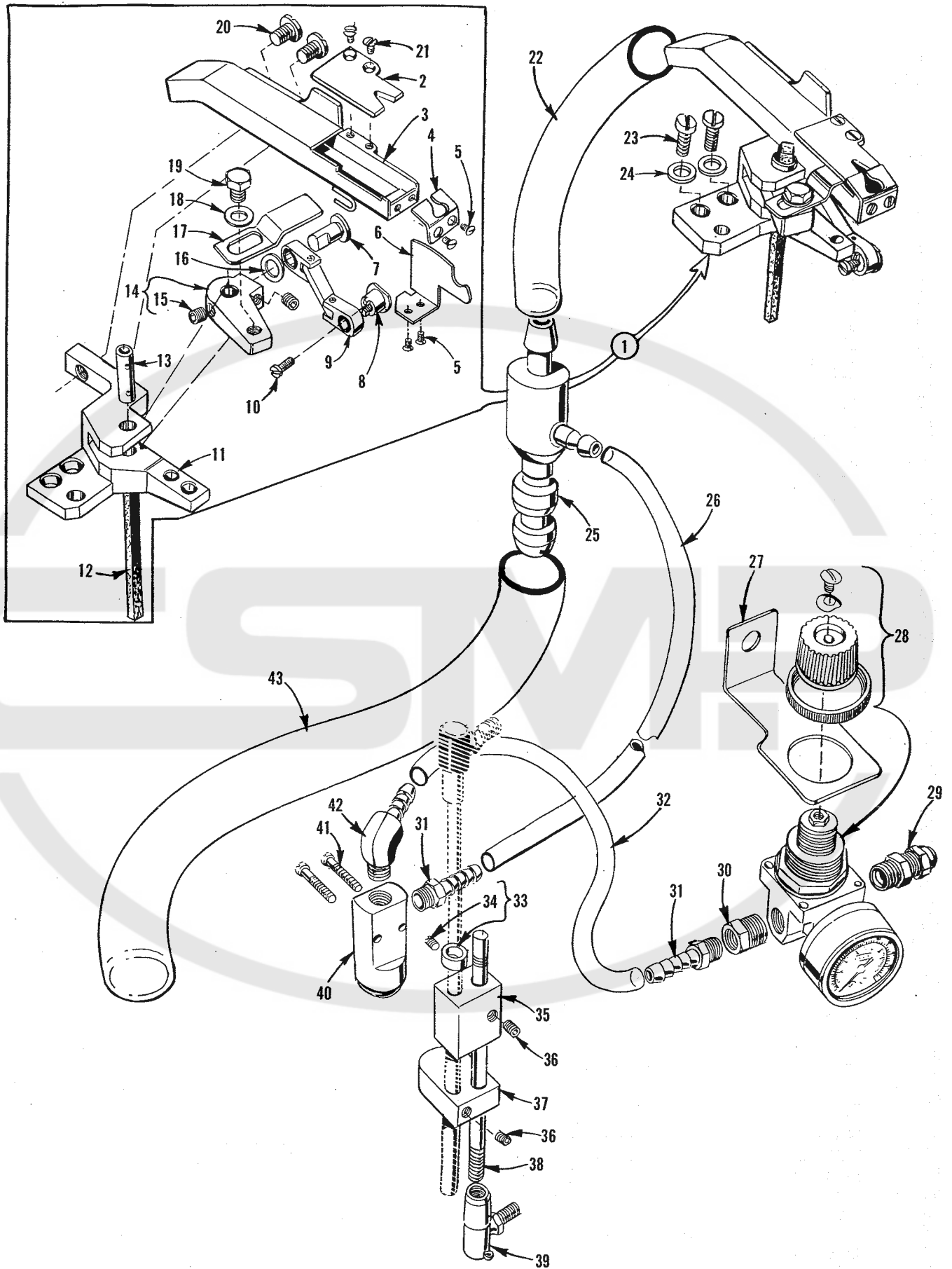

**"AIR-KLIPP" CHAIN CUTTER AND PNEUMATIC PARTS**  
 (For Styles 395-26V, -28V, -40V, -42V)

<u>Ref. No.</u>	<u>Part No.</u>	<u>Description</u>	<u>Amt. Req.</u>
1	G29911	"Air-Klipp" Chain Cutter Assembly -----	1
2	99670 C	Knife, upper -----	1
3	99676 E	"Air-Klipp" Chain Cutter Tube, complete -----	1
4	99677	Inlet Part, marked "GA", has a point .032 inch (.8mm) slot and .154 inch (3.9mm) opening. For threads 60/3 up to 40/4. -----	1
-	99677 C	Inlet Part, marked "GD", has a point .046 inch (1.2mm) slot and .212 inch (5.4mm) opening. For heavy threads such as 30/6. -----	1
5	22716 A	Screw -----	4
6	99665	Guard, fabric -----	1
7	99671	Stud -----	1
8	99673	Bushing, Link -----	1
9	99672	Link, knife driving -----	1
10	G22797 A	Screw -----	1
11	99663	Base -----	1
12	15430 L	Wick, oil -----	1
13	99674	Stud -----	1
14	99666	Lever, knife -----	1
15	22894 W	Screw, set -----	2
16	95910	Washer -----	1
17	99669	Knife, movable -----	1
18	53634 C	Washer -----	1
19	G22519	Screw -----	1
20	22829	Screw -----	2
21	22716	Screw -----	2
22	671 B-12	Tube, air, 12 inches (304.8mm) long -----	1
23	22541 B	Screw -----	2
24	39835 G	Washer -----	2
25	671 D-2	Jet, air -----	1
26	671 B-3	Tube, air, 45 inches (1143.0mm) long -----	1
27	39583 A	Bracket, mounting -----	1
28	671 D-7	Regulator and Gauge, pressure -----	1
29	671 F-8	Fitting, straight -----	1
30	671 F-6	Bushing, reducer -----	1
31	671 F-1	Fitting, male -----	2
32	671 B-1	Tube, air, 36 inches (914.4mm) long -----	1
33	61242	Collar, pitman rod -----	1
34	88	Screw -----	2
35	671-2	Block, air valve mounting -----	1
36	22651 CB-4	Screw, set -----	2
37	671-3	Block, air valve actuator -----	1
38	1453 A	Rod, pitman -----	1
39	21371 MZ	Connection -----	1
40	671-1	Valve, air -----	1
41	22729 B	Screw -----	2
42	671 F-2	Fitting, elbow -----	1
43	671 B-11	Tube, air, 30 inches (762.0mm) long -----	1
-	670 E-2	Tie, cable (not shown) -----	3

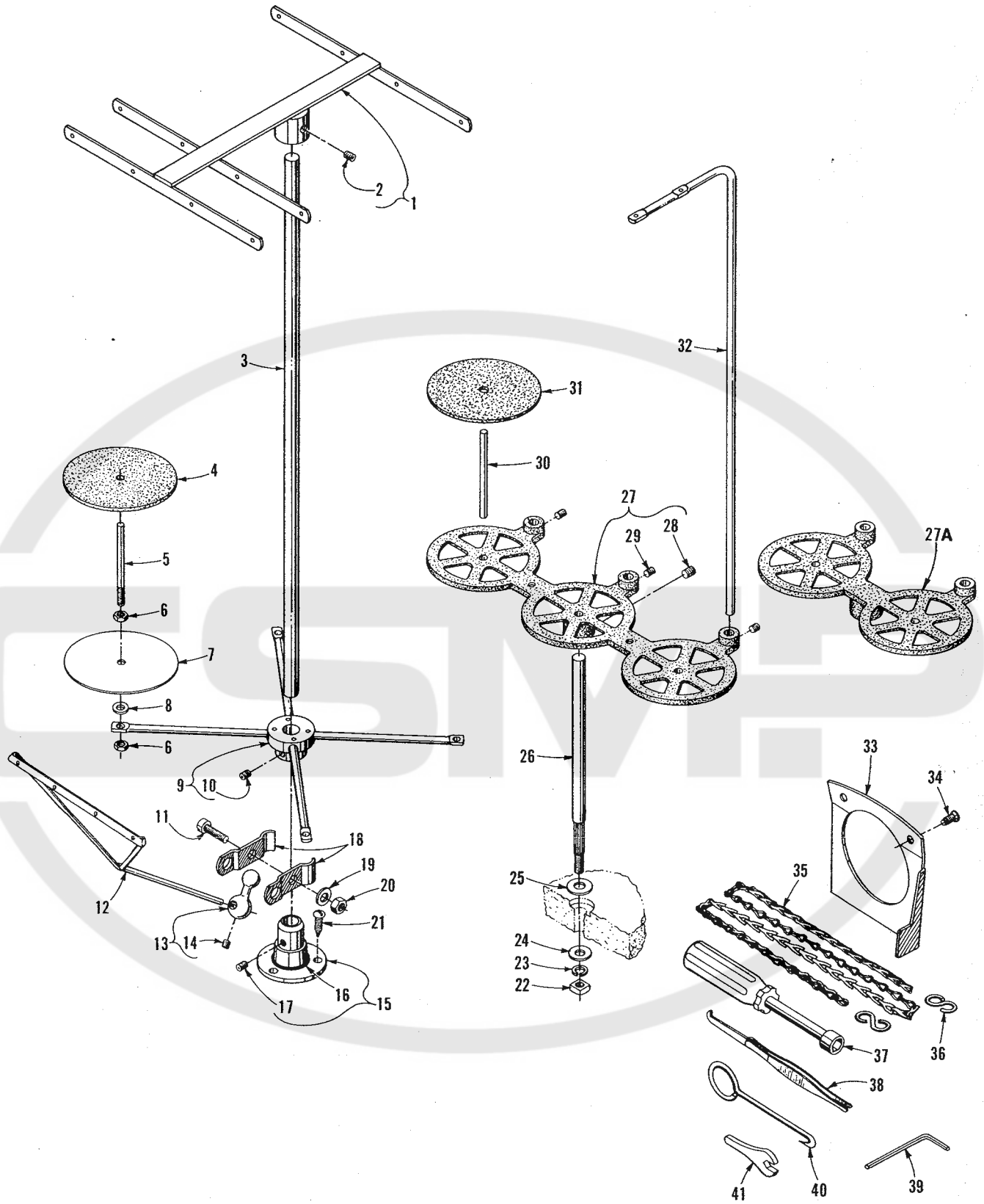

THREAD STANDS, ACCESSORIES AND MISCELLANEOUS TOOLS

<u>Ref. No.</u>	<u>Part No.</u>	<u>Description</u>	<u>Amt. Req.</u>
1	21114 AQ-4	Eyelet Support, Styles -22, -23 -----	1
2	22651 CD-4	Screw -----	1
3	21104 B-20	Rod, thread stand, Styles -22, -23 -----	1
4	21104 V	Pad, thread cone, Styles -22, -23 -----	4
5	21114 W	Pin, spool, Styles -22, -23 -----	4
6	258 A	Nut, Styles -22, -23 -----	8
7	21114	Disc, spool seat, Styles -22, -23 -----	4
8	652-16	Washer, Styles -22, -23 -----	4
9	21114 D-4	Support, spool, Styles -22, -23 -----	1
10	22651 CD-5	Screw -----	2
11	22810	Screw, Styles -22, -23 -----	1
12	21114 S-4	Eyelet, lead, Styles -22, -23 -----	1
13	21114 T	Ball, lead eyelet socket, Styles -22, -23 -----	1
14	22651 CD-4	Screw -----	1
15	21114 A	Base, thread stand, Styles -22, -23 -----	1
16	660-738	Cap -----	1
17	22651 CD-4	Screw -----	1
18	21114 U	Split Socket, ball, Styles -22, -23 -----	2
19	652-16	Washer, Styles -22, -23 -----	1
20	21104 H	Nut, Styles -22, -23 -----	1
21	SC-330	Screw, Styles -22, -23 -----	3
22	651 A-16	Nut, all Styles except -22, -23 -----	1
23	WA9 A	Washer, lock, all Styles except -22, -23 -----	1
24	652 J-16	Washer, all Styles except -22, -23 -----	1
25	652 J-24	Washer, all Styles except -22, -23 -----	1
26	21104 AA	Rod, thread stand, all Styles except -22, -23 -----	1
27	21130 W-3	Support, cone, all Styles except -20, -21, -22, -23 --	1
27A	21130 W-2	Support, cone, Styles -20, -21 -----	1
28	22650 CE-6	Screw -----	1
29	22650 CB-4	Screw, for support No. 21130 W-3 -----	3
-	22650 CB-4	Screw, for support No. 21130 W-2 -----	2
30	69 S	Pin, spool, all Styles except -20, -21, -22, -23 -----	3
-	69 S	Pin, spool, Styles -20, -21 -----	2
31	21104 V	Pad, all Styles except -20, -21, -22, -23 -----	3
-	21104 V	Pad, Styles -20, -21 -----	2
32	21113 F	Eyelet, thread stand, all Styles except -20, -21, -22, -23 -----	3
-	21113 F	Eyelet, thread stand, Styles -20, -21 -----	2
33	21375 BB	Guard, belt -----	1
34	80	Screw -----	2
35	421 D-34	Chain, presser foot lifter, 32 3/64 inch (812.8mm) long -----	1
36	660-264	"S" Hook -----	2
37	21388 AU	Wrench , socket, 3/8 inch (9.5mm) hexagon -----	1
38	660-240	Tweezers, thread -----	1
39	WR-56	Wrench, allen, 1/8 inch (3.2mm) hexagon, Styles -22, -23 -----	1
40	21227 BF	Extractor, cam -----	1
41	116	Wrench, open end, 9/32 inch (7.1mm) -----	1
	652-24	Washer, all Styles except -20, -21, -22, -23 (not shown) -----	8
	660-458	Cover, dust (not shown) -----	1
	28604 R	Container of Oil, 16 ounces (455ml.), Spec 175, (not shown) -----	1

NUMERICAL INDEX OF PARTS

Part No.	Page No.	Part No.	Page No.	Part No.	Page No.
WA9 A	45	6042 A	37	22729 A	41
30-106 Blk	31	8372 A	33,39	22729 B	37,43
40-46	31,33	12538	39	22729 D	35
51-103 Blk	27	12865	39	22729 E	35
51-228 Blk	31	14077	37	22738	37,41
WR-56	45	14077 A	33	22738 B	41
CO-67 E	31	15430 L	43	22738 G	39
69 S	45	21104 B-20	45	22743	27,41
73 C	41	21104 H	45	22747 B	31
73 X	39	21104 V	45	22768 B	41
HA73 B	41	21104 AA	45	22768 C	31
77	35	21113 F	45	22769 B	31
77 Q	31	21114	45	22782 A	33
80	45	21114 A	45	22791 H	39
86 X	29	21114 D-4	45	22797 A	33
87	33	21114 S-4	45	G22797 A	43
87 U	31,33,35	21114 T	45	22799 B	41
88	39,43	21114 U	45	22806 A	39
88 B	33,37	21114 W	45	22810	45
90	27,29,37	21114 AQ-4	45	22829	43
93 A	33	21130 W-2	45	22847 B	39
97	35	21130 W-3	45	22873 C	41
97 A	31	21227 BF	45	22892 B	37
116	45	21371 MZ	43	22894 C	31,35
138	27	21375 BB	45	22894 W	43
154 GAS	33	21388 AU	45	22894 AE	27,35
222 D	41	22503 F	35	28604 R	45
258	31,33	22513	29,33	29126 DF	35
258 A	39,45	22513 C	41	29477 GW	27
303	41	G22519	43	29477 JM	31
SC330	45	22524	37	29477 KE	31
376 A	39	22528	33	29477 MC	31
421 D-34	45	22541	27	29481 L	41
482 C	35	22541 B	29,33,43	G29911	43
605	39	22559 H	37	39151	35
627	39	22562 A	27,35	39501 K	27,29
651 A-16	45	22564 G	35	39501 AP	29
652-16	45	22565	27,35	39501 DC	29
652-24	45	22565 F	27,31,33	39501 DAF	29
652 J-16	45	22565 H	35	39501 DAG	29
652 J-24	45	22565 S	27,35	39503 L	41
660-142	39	22566 B	39	39505 B	41
660-204	31	22567 D-12	29	39505 E	41
660-206	35	22569	27	39505 F	41
660-207	33	22569 B	27,31,33,39	39505 H	41
660-240	45			39505 W	41
660-243	27	22569 D	27,39	39508 A	35
660-264	45	22569 G	33	39508 B	35
660-268	31	22569 K	27	39520 A	41
660-443	31	22571 E	27	39520 H	41
660-458	45	22585 A	37	39520 W	41
660-738	45	22585 G	37	39521 G	31
666-94	31	22586 T	29	39521 DA	31
666-255	35	22587 J	37	39524 B-1/8	41
667 D-8	27	22587 M	31	39524 D	41
670 E-2	43	22588 J	37	39524 W	41
671-1	43	22593	41	39525 A	37
671-2	43	22596 E	33	39525 D	37
671-3	43	22596 H	31	39525 E	37
671 B-1	43	22597 E	39	39525 M	37
671 B-3	43	22650 CB-4	45	39525 P	37
671 B-11	43	22650 CE-6	45	39525 R	37
671 B-12	43	22651 CB-4	43	39526 B	41
671 D-2	43	22651 CD-4	45	39526 H	41
671 D-7	43	22651 CD-5	45	39526 W	41
671 F-1	43	22653 B-12	37	39530	41
671 F-2	43	22653 D-4	29	39530 B	41
671 F-6	43	22657 D-12	27	39530 C	41
671 F-8	43	22704	39	39530 E	41
1025 L	35	22716	43	39530 P	41
1453 A	43	22716 A	43	39532 A	29

NUMERICAL INDEX OF PARTS

<u>Part No.</u>	<u>Page No.</u>	<u>Part No.</u>	<u>Page No.</u>	<u>Part No.</u>	<u>Page No.</u>
39532 D.....	29	39556 K.....	39	39589 AK-1/2.....	41
39534.....	33	39556 L.....	39	39589 AK-3/4.....	41
39534 G.....	33	39556 M.....	39	39589 AK-1.....	41
39534 H.....	33	39557.....	27	39589 AL.....	41
39534 R.....	27	39557 A.....	27	39590.....	31
39535.....	33	39557 B.....	27	39590 D.....	31
39535 C.....	33	39557 C.....	27	39590 G.....	31
39535 D.....	33	39557 E.....	27	39590 H.....	31
39535 J.....	33	39557 F.....	27	39590 J.....	31
39536 B.....	33	39560 A.....	35	39590 N.....	31
39536 C.....	33	39563 F.....	27	39590 P.....	31
39536 E.....	33	39563 G.....	33	39590 R.....	31
39536 AE.....	33	39563 H.....	39	39590 S.....	31
39536 AF.....	33	39563 J.....	33	39590 T.....	31
39538.....	33	39563 W.....	27	39590 X.....	31
39540 B-8.....	33	39568 A.....	33	39591 A.....	31
39540 B-10.....	33	39568 B.....	39	39591 B.....	31
39540 B-12.....	33	39568 D.....	39	39591 K.....	31
39540 B-14.....	33	39568 E.....	39	39592 Z.....	39
39541 A.....	31	39568 G.....	27	39592 AA.....	39
39543.....	35	39568 J.....	27,41	39592 AB.....	39
39543 A.....	35	39568 L.....	39	39592 AC.....	39
39543 E.....	35	39568 W.....	39	39592 AD.....	39
39543 K.....	35	39568 AC.....	33	39592 AF.....	39
39543 M.....	35	39570.....	37	39592 AG-3.....	39
39543 P.....	35	39570 J.....	37	39592 AG-5.....	39
39543 S.....	35	39571 B.....	37	39592 AH.....	39
39543 T.....	35	39571 D.....	37	39592 AK.....	39
39543 U.....	35	39571 F.....	37	39592 AL.....	39
39543 W.....	35	39572.....	37	39592 AM.....	39
39543 X.....	35	39573 A.....	37	39592 AN.....	39
39543 Y.....	33	39573 E.....	37	39592 AR-4.....	39
39544.....	35	39573 H.....	37	39592 AR-5.....	39
39544 B.....	35	39573 J.....	37	39592 AR-8.....	39
39544 D.....	35	39573 K.....	31	39593 C.....	29
39544 J.....	35	39573 AA.....	31	39593 D.....	29
39544 N.....	35	39578 F.....	27	39593 H.....	27
39544 S.....	35	39578 P.....	33	39594 G.....	27
39544 U.....	35	39578 R.....	33	39594 H.....	27
39544 V.....	35	39578 T.....	27	39594 N.....	31,33,35
39544 X.....	31	39578 U.....	27	39594 R.....	27
39549.....	37	39580 A.....	37	39595.....	29
39549 J.....	37	39580 E.....	37	39597 A.....	41
39550 C.....	37	39580 F.....	37	39597 W.....	41
39550 E.....	37	39580 AE.....	37	39835 G.....	33,43
39550 J.....	37	39580 BA.....	37	39855.....	39
39550 K.....	37	39582 D.....	29	41071 G.....	29
39550 M.....	37	39582 F.....	29	43139 A.....	39
39550 S.....	37	39582 H.....	29	51295 B.....	29
39550 T.....	37	39582 J.....	29	53634 C.....	33,43
39550 U.....	37	39582 L.....	27	55235 D.....	37
39550 Z.....	37	39582 V.....	27	55235 E.....	37
39551 G.....	33	39582 W.....	27	61242.....	43
39551 H.....	33	39582 X.....	29	61303 D.....	41
39551 J.....	33	39582 Y.....	29	61351 K-625.....	33
39552 P.....	31	39582 AG.....	27	79077.....	41
39552 R.....	33	39582 BR.....	29	95910.....	43
39552 U.....	31	39582 BS.....	37	99663.....	43
39552 Z.....	33	39582 GG.....	29	99664.....	39
39552 AC.....	33	39582 EJ.....	27	99665.....	43
39552 AD.....	33	39582 EK.....	27	99666.....	43
39552 AG.....	33	39582 EL.....	27	99669.....	43
39555 A.....	39	39582 A.....	43	99670 C.....	43
39555 B.....	39	39589 AA.....	41	99671.....	43
39555 C.....	39	39589 AB.....	41	99672.....	43
39555 D.....	39	39589 AC.....	41	99673.....	43
39555 F.....	39	39589 AD.....	41	99674.....	43
39555 P.....	31	39589 AF.....	41	99676 E.....	43
39555 R.....	31	39589 AG.....	41	99677.....	43
39556 A.....	27	39589 AH.....	41	99677 C.....	43
39556 F.....	39	39589 AJ.....	41	99679.....	29

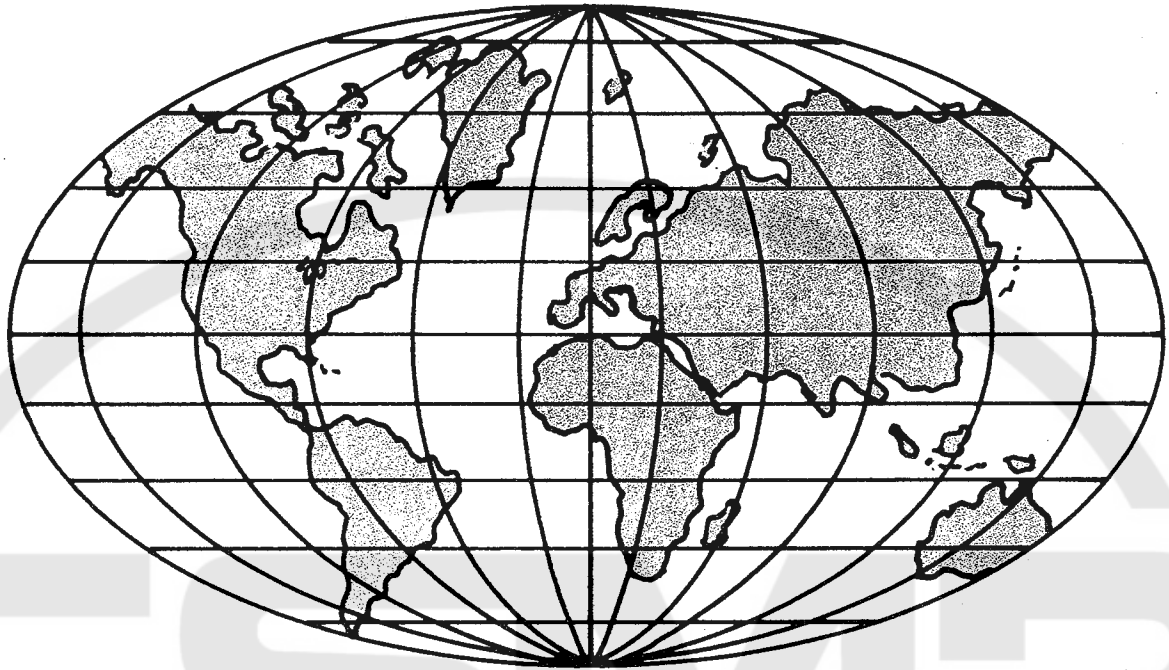

## WORLDWIDE SALES AND SERVICE

UNION SPECIAL maintains sales and service facilities throughout the world. These offices will aid you in the selection of the right sewing equipment for your particular operation. UNION SPECIAL representatives and servicemen are factory trained and are able to serve your needs promptly and efficiently. Whatever your location, there is a UNION SPECIAL representative to serve you. Check with him today.

It is important to remember that LEWIS AND COLUMBIA machines are also products of UNION SPECIAL, thus offering the industry the most complete line of the Finest Quality sewing machines.

Norcross, GA  
Chicago, IL  
Dallas, TX  
Commerce, CA  
New York, NY  
Philadelphia, PA  
Woburn, MA  
Opa-Locka, FL  
Montreal, Quebec  
Toronto, Ontario  
Catano, Puerto Rico  
Brussels, Belgium  
Leicester, England  
Paris, France  
Stuttgart, W. Germany  
Hong Kong

Other Representatives throughout  
all parts of the world

---

 **Union Special**<sup>®</sup>  
Finest Quality Industrial Sewing Equipment

---