

CATALOG NO.

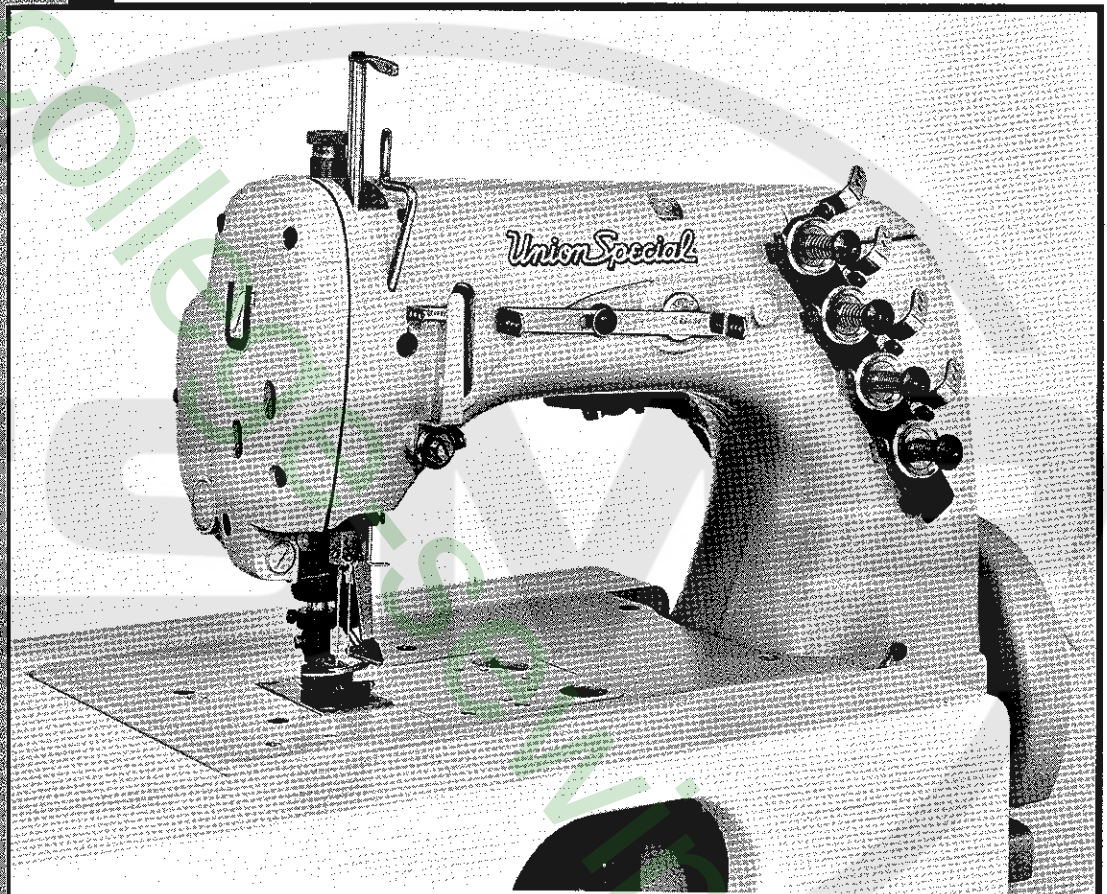
104 BV

First Edition

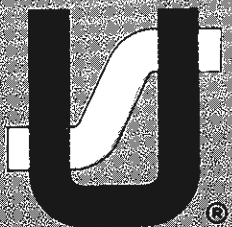
STYLE

51500 BV-16

# ADJUSTING INSTRUCTIONS AND LIST OF PARTS



**STREAMLINED FIFTY THOUSAND SERIES  
TWO NEEDLE "DOUBLE-LOCK" STITCH  
MACHINE WITH TOP COVER THREAD**



Finest Quality

*Union Special*<sup>®</sup>  
Industrial Sewing Equipment

Catalog No. 104 BV

**INSTRUCTIONS  
FOR  
ADJUSTING AND OPERATING  
AND  
LIST OF PARTS**

**CLASS 51500**

**Style**

**51500 BV-16**

First Edition

Copyright 1980

By

Union Special Corporation  
Rights Reserved in All Countries

Printed in U.S.A.    November, 1980

## INTRODUCTION

This technical manual has been prepared to guide you in the maintenance of your new UNION SPECIAL sewing machine. Careful attention to the instructions for operating and adjusting these machines will enable you to maintain the superior performance and reliability designed and built into every UNION SPECIAL machine.

The Adjusting Instructions portion of this manual explains in detail the proper setting for each of the components related to forming the stitch and completing the functions of the machine. Figures are used to illustrate the adjustments using reference letters to point out the specific items discussed.

The adjustments are presented in a sequence so that a logical progression is accomplished. Some adjustments performed out of sequence may have an adverse effect on the function of other related parts.

Implementation of preventative maintenance procedures can bring about significant improvements in operator productivity by avoiding costly equipment breakdowns. Whenever it becomes necessary to make repairs or replace parts on your machine, be sure to insist on genuine UNION SPECIAL Repair Parts. These parts are designed specifically for your machine and manufactured with utmost precision to assure long lasting service.

To simplify identification of repair parts, where the construction permits, each part is stamped with its part number. Part numbers represent the same part, regardless of catalog in which they appear.

### IDENTIFICATION OF MACHINE

Each UNION SPECIAL machine is identified by a Style number on a name plate on the machine. Style numbers are classified as standard and special. Standard Style numbers have one or more letters suffixed, but never contain the letter "Z". Example: "Style 51500 BV". Special Style numbers contain the letter "Z". When only minor changes are made in a standard machine, a "Z" is suffixed to the standard Style number. Example: "Style 51500 BVZ".

### STYLE OF MACHINE

Streamlined Flat Bed, Plain Feed Machine, Two Needles, Two Loopers, One Spreader and Single Disc Looper Thread Takeup, Lateral Looper Travel, Light Weight Presser Bar and Needle Bar Driving Mechanism, Single Reservoir Enclosed Automatic Lubricating System and Filter Type Oil Return Pump. Maximum Work Space to Right of Needle Bar 7 3/4 Inches (196.8 mm).

51500 BV-16 Medium throw high speed machine for attaching facing material to the pocket lining of trousers, jeans and similar operations on light to medium weight materials. Produces two rows of 401 stitches with cover thread interlocking on the top. Presser foot equipped with a guide. Seam specification 408-SSaa-1. Type 147 GS needle. Standard gauge No. 16 only. Maximum recommended speed 5000 R.P.M.

### NEEDLES

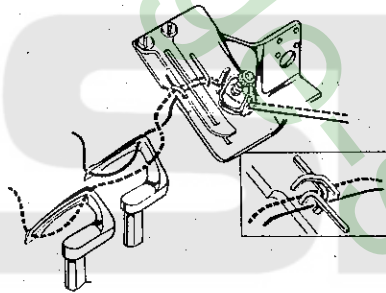
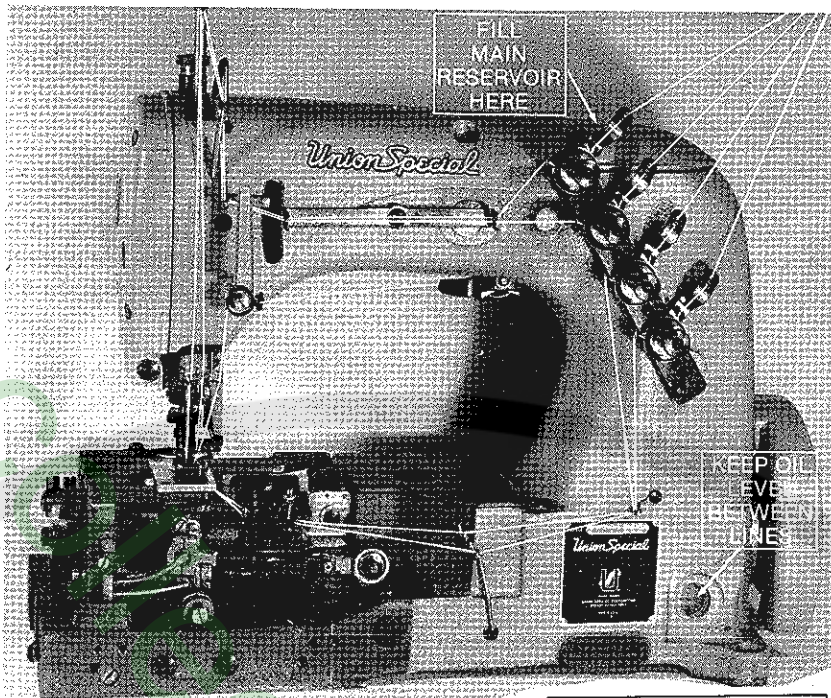
Each UNION SPECIAL needle has both a type and size number. The type number denotes the kind of shank, point, length, groove, finish and other details. The size number, stamped on the needle shank, denotes the largest diameter of blade, measured in thousandths of an inch, midway between shank and eye. Collectively, type and size number represent the complete symbol, which is given on the label of all needles packaged and sold by Union Special.

The standard recommended needle for Style 51500 BV-16 is Type 147 GS. It has a round shank, round point, long, double groove, struck groove, ball eye, spotted, short point, undersize eye and grooves, one step reduction, chromium plated and is available in sizes 080/032, 090/036, 100/040, 110/044, 125/049, 140/054, 150/060, 170/067.

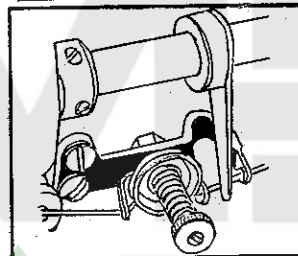
To have needle orders promptly and accurately filled, an empty package, a sample needle, or the type and size number should be forwarded. Use description on label. A complete order would read: "1000 needles, Type 147 GS, Size 100/040".

Selection of the proper needle size is determined by the size of thread used. Thread should pass freely through needle eye in order to produce a good stitch formation.

# INSTRUCTIONS FOR MECHANICS



**CAUTION!**  
FILL ALL OIL RESERVOIRS  
BEFORE STARTING.  
MACHINE HAS BEEN DRAINED  
BEFORE SHIPPING.



**FIGURE 1**  
**THREADING AND OILING DIAGRAM FOR STYLE**  
**51500 BV-16**

Thread machine as indicated (Fig. 1). The looper and spreader threading has been enlarged for clarity.

The oil has been drained from the machine before shipping and the reservoir must be filled before beginning to operate. Use a straight mineral oil having a Saybolt viscosity of 90 to 125 seconds at 100° Fahrenheit.

Oil is filled at the spring cap in the top cover and the level is checked at the sight gauge on the front of the machine. The oil level should be maintained between the red lines on the gauge. The capacity of the oil reservoir is approximately 12 ounces (354.88 ml.).

The machine is automatically lubricated and no oiling other than keeping the main reservoir filled is necessary.

A daily check before the morning start should be made and oil added if required. Oil which has gone

through the machine is filtered and pumped back into the main reservoir making too frequent oilings unnecessary. Excessive oil in the main reservoir may be drained at the plug screw in the main frame directly under the handwheel.

**CAUTION!** Oil has been drained from the main reservoir before shipment, so the reservoir must be filled to the proper level as indicated on oil gauge before beginning to operate. Run machine slowly for several minutes to distribute the oil to the various parts. Full speed operation can then be expected without damage.

## RECOMMENDED OIL

Use a straight mineral oil having a Saybolt viscosity of 90 to 125 seconds at 100° Fahrenheit in the main reservoir. This is equivalent to Union Special specification No. 175.

## ALIGNING THE NEEDLE BAR

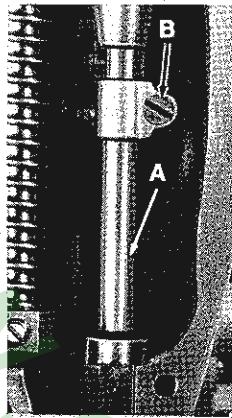


FIGURE 2

Insert a new set of needles (Type and Size as specified) and align the needle bar so that the needles correspond with the needle holes in the throat plate. To turn needle bar (A, Fig. 2), loosen needle bar clamp screw (B) and turn bar as required. Tighten clamp screw.

NOTE: Needle bar head is torqued to 17-19 in. lbs. (20-22 cm/kg).

## SYNCHRONIZING LOOPER AND NEEDLE MOTIONS

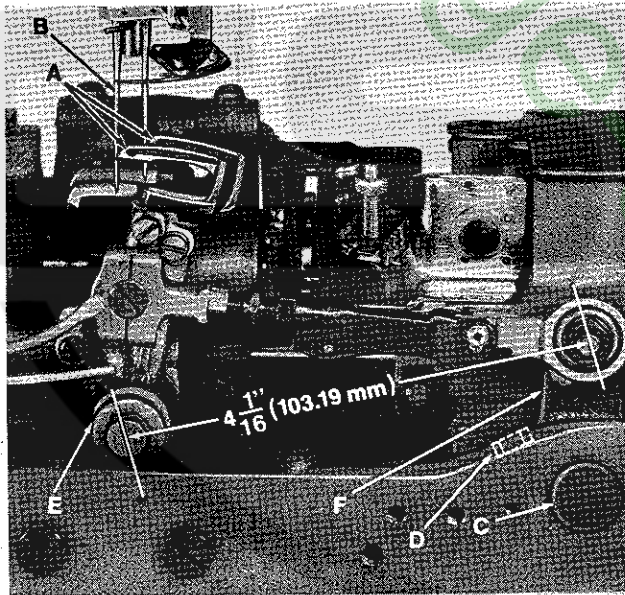


FIGURE 3

Insert the loopers (A, Fig. 3) in the looper rocker, pushing them all the way down and tighten screws against flat on shanks of loopers. Turn handwheel in operating direction until the point of the front looper, moving to the left is even with the left side of the left needle (B). Note the height of the eye of the needle with respect to the looper point, then turn handwheel in the reverse direction until the looper point again moves to the left, and is even with the left side of the needle. If the motions synchronize, the height of the eye of the needle with respect to the looper point will be the same. A variation of .005 inch (.127 mm) is allowable. If the distance from the eye of the needle to the point of the looper is greatest when the pulley is

turned in the operating direction, move the looper drive shaft synchronizing stud (C) to the rear. Moving it in the opposite direction acts the reverse.

Moving the synchronizing stud is accomplished as follows: Loosen the clamp screw (D) in the looper drive lever. To move stud to rear (away from operator), a light tap with a small hammer, directly on the stud, is all that is required. To move stud forward (toward operator), remove the cloth plate, (2) fillister head screws in oil reservoir top cover and oil reservoir back cover, then, a light tap on the looper drive lever rocker shaft, toward the operator, is all that is required. All end play must be removed from the looper drive lever rocker shaft. Tighten screw (D).

With the looper at the extreme right end of its travel, check the location of the centerline of the right looper connecting rod bearing, using gauge No. 21227 CX and place hole in gauge over threaded stud. The left end of the gauge should locate against the right side of the looper rocker cone (E). If adjustment is necessary, loosen the clamp screw (D) and reposition the looper drive lever (F) as required. Tighten clamp screw. If gauge is not available, setting can be checked with a scale. The distance between the centerline of the looper rocker cone and the centerline of the looper lever stud should be 4 1/16 inches (103.19 mm) (Fig. 3).

## SETTING THE LOOPERS

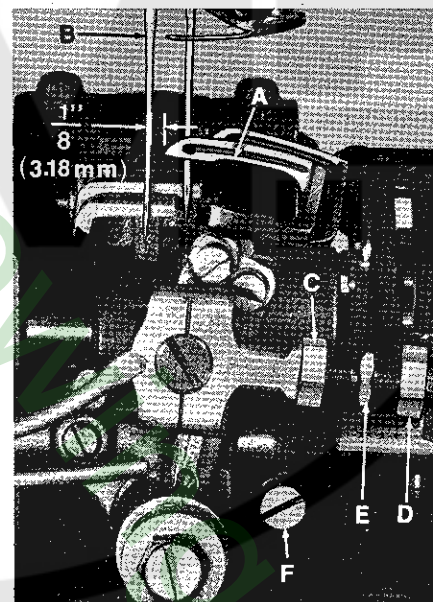


FIGURE 4

Insert a new set of needles in the needle holder (Type and Size as specified). The looper gauge is 1/8 inch (3.18 mm), set the front looper (A, Fig. 4) so the distance from the center of the left needle (B) to the point of the front looper is 1/8 inch (3.18 mm), when the looper is at its farthest position to the right. Looper gauge No. 21225-1/8 can be used in making this adjustment.

If adjustment is required, loosen nut (C, Fig. 4) (it has a left hand thread) and nut (D) on connecting rod (E), turn the connecting rod forward or backward to obtain the 1/8 inch (3.18 mm) dimension. Retighten both nuts,

first nut (D) and then nut (C). Make sure the left ball joint is in vertical position and does not bind after adjustment.

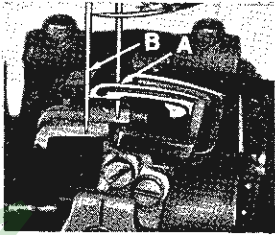


FIGURE 5

As the looper (A, Fig. 5) moves to the left behind the needle, its point should be as close as possible to the needle (B) but not deflect it.

If adjustment is necessary loosen lock screw (F, Fig. 4) and position the looper point to the needle as described. Tighten lock screw (F) when setting is obtained and recheck the adjustment.

### SETTING THE FEED DOG

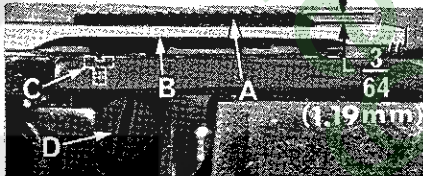


FIGURE 6

Set the feed dog (A, Fig. 6) in the throat plate (B) so there is equal clearance on all sides. See that the tips of the teeth extend the depth of a tooth or approximately 3/64 inch (1.19 mm) above the throat plate and are parallel with the throat plate at high point of travel. Adjust the supporting screw (C), under the feed dog, to maintain this setting. Screw (D) is used to hold feed dog in position.

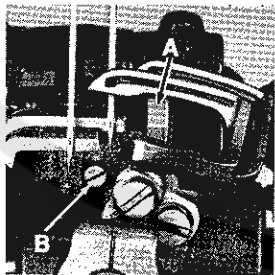


FIGURE 7

If feed dog teeth are not parallel with the throat plate, loosen nut (A, Fig. 7) and turn screw (B) clockwise to lower the front teeth, or counterclockwise to raise the front teeth. Retighten nut when feed dog is set properly.

**CAUTION!** See that there is sufficient space between underside of feed dog and top of looper.

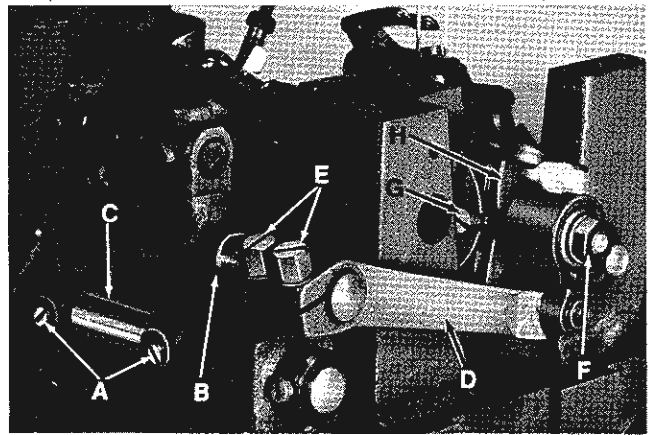


FIGURE 8

Should it be necessary to move the feed dog to the left or right, loosen screws (A, Fig. 8) which hold the feed rocker (B) onto the feed rocker shaft (C), and move the feed rocker to desired position and retighten screws. Make sure the feed rocker arm (D) does not bind after making this adjustment.

When the handwheel is turned in the operating direction the feed dog should have equal clearance on both ends of the throat plate slots with feed travel set to desired stitch length.

Should it be necessary to move the feed dog forward or backward, loosen screws (E, Fig. 8) which clamp the feed rocker arm to the feed rocker and move the feed rocker forward or backward as needed and retighten screws.

### CHANGING STITCH LENGTH

Set the stitch to required length. This is accomplished by loosening the locknut (F, Fig. 8) 1/2 turn (it has a left hand thread) on the end of the stitch regulating stud and turning the stitch adjusting screw (G) located under the left end of the cloth plate, in the head of the mainshaft (H). Turning the screw clockwise shortens the stitch and turning it in a counterclockwise direction lengthens the stitch. Retighten the locknut (F) securely. Torque to 55 in. lbs. (63 cm/kg).

**NOTE:** A change in stitch length will require a change in rear needle guard setting.

### SETTING THE REAR NEEDLE GUARD



FIGURE 9

Rotate handwheel in operating direction so that the needle bar is in its lowest position. Continue to rotate until the loopers, moving to the left, approach the needles and the point of the looper (A, Fig. 9) is even

with the right side of the needle. At this point, the rear needle guard (B) should contact the needles lightly. Do not deflect needles. The vertical face of the guard must be below the eye of the needle when needle is at its lowest position. To move needle guard forward or backward, loosen screw (C), move needle guard as required, and retighten screw. To raise or lower needle guard, loosen screw (C) and turn screw (D) clockwise to lower needle guard or counterclockwise to raise it. Retighten screw (C) after guard is properly set.

#### THREAD TENSION RELEASE



FIGURE 10

The thread tension release is set correctly when it begins to function as the presser foot is raised to within 1/8 inch (3.18 mm) of the end of its travel and is entirely released when the presser foot has reached its highest position.

If adjustment is needed, loosen tension release lever screw (A, Fig. 10), located at the back of the machine and move tension disc separator as required. Retighten screw. After adjustment there should be no binding at any point.

#### SETTING HEIGHT OF PRESSER BAR

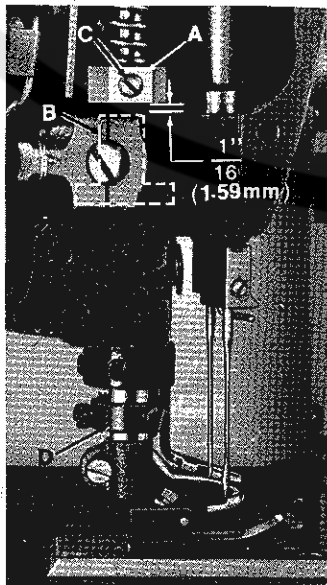


FIGURE 11

There should be approximately 1/16 inch (1.59 mm) clearance between lower surface of the presser bar connection guide (A, Fig. 11) and the top of the spreader holder carrier (B), when the presser foot is resting on the throat plate, with the feed dog down below the throat plate.

If adjustment is needed, turn handwheel in operating direction until the needle bar is in the low position and loosen screw (C, Fig. 11). Then, while holding presser foot down on the throat plate surface, pry up presser bar connection and guide with a screwdriver to obtain the 1/16 inch (1.59 mm) setting and tighten screw. Check setting by turning handwheel so that the needle bar is at its highest position and see if presser foot can be removed.

Set the presser bar collar (D) so that the presser foot cannot contact the spreader when lifted to its highest position.

#### PRESSER FOOT PRESSURE

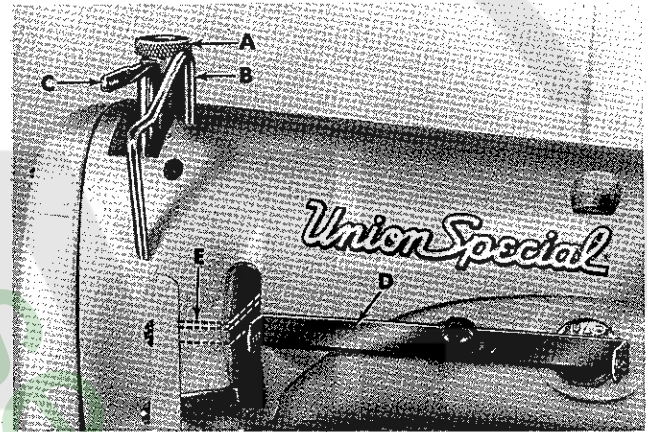


FIGURE 12

Regulate the presser spring regulating screw (A, Fig. 12) so that it exerts only enough pressure on the presser foot to feed the work uniformly when a slight tension is placed on the fabric. Turning it clockwise increases the pressure, counterclockwise acts the reverse.

#### SETTING NEEDLE THREAD TAKEUP WIRE AND FRAME EYELET

Set the needle thread takeup wire (B, Fig. 12) so that it contacts the needle threads in the needle bar eyelet (C) when it reaches its lowest position. Lower this setting for a smaller needle thread loop and raise it for a larger loop. Set the needle thread frame eyelet (D) so that it is parallel and in line with the needle lever thread eyelet (E) when the needle bar is at the top of its stroke and starting its downward movement.

## SETTING AND TIMING THE SPREADER

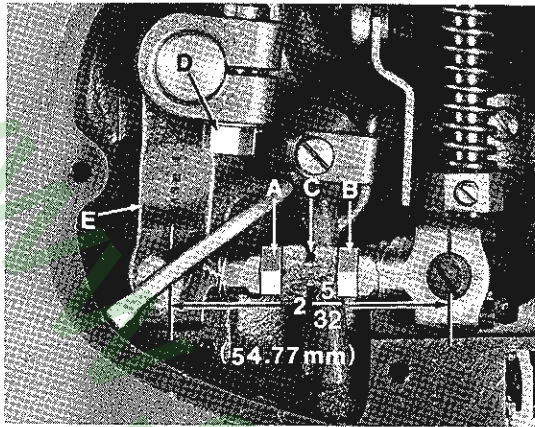


FIGURE 13

The distance between the centerline of the spreader connecting rod ball joints should be  $2 \frac{5}{32}$  inches (54.77 mm). Adjustment is made by loosening locknut (A, Fig. 13) (it has a left hand thread) and nut (B). Turn the connecting rod (C) as required. Then retighten both nuts, first nut (B) and then nut (A).

Clearance between the connecting rod ball joint and machine casting must be maintained. To obtain sufficient clearance, loosen nut (D, Fig. 13) and reposition arm (E) as required. Retighten nut (D).

NOTE: This clearance should be checked again after setting the spreader travel.

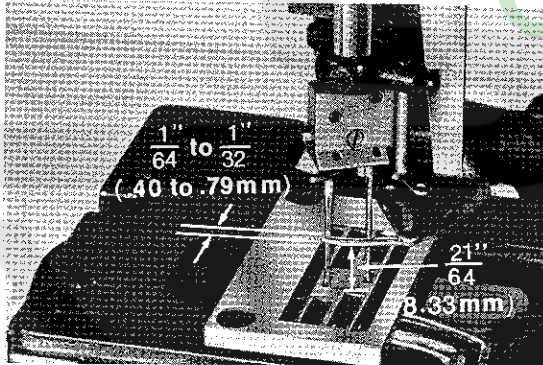


FIGURE 14

Set the spreader to clear the left needle shank by  $\frac{1}{64}$  to  $\frac{1}{32}$  inch (.40 to .79 mm) (Fig. 14). A height adjustment of  $\frac{21}{64}$  inch (8.33 mm) between the bottom of the spreader and the top of the throat plate must be maintained. Height and position adjustments are obtained by loosening screws (B, Fig. 19) and moving spreader as required. Retighten screws.

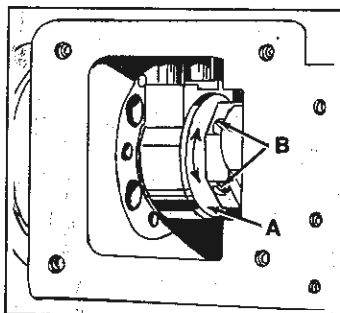


FIGURE 15

The timing of the spreader travel is determined by the position of the spreader drive eccentric (A, Fig. 15) on the crankshaft. To check the timing, rotate the handwheel so that the needle bar is at its highest point. Continue to rotate the handwheel until the needle bar has descended  $\frac{1}{8}$  inch (3.18 mm). The spreader should now begin to move to the right. To change the spreader timing, loosen screws (B), then advance or retard eccentric on the shaft as required. Tighten screws (B).

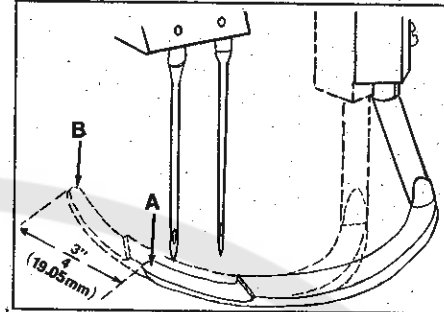


FIGURE 16

The travel of the spreader from point (A, Fig. 16) to point (B) should be  $\frac{3}{4}$  inch (19.05 mm). Adjustment is made by loosening nut (A, Fig. 17) and moving the ball joint in the rocker shaft lever (B) as required. The further away from the rocker shaft the ball joint is located, the shorter the travel of the spreader. Retighten nut (A) after adjustment. Check clearance between connecting rod ball joint and machine casting.

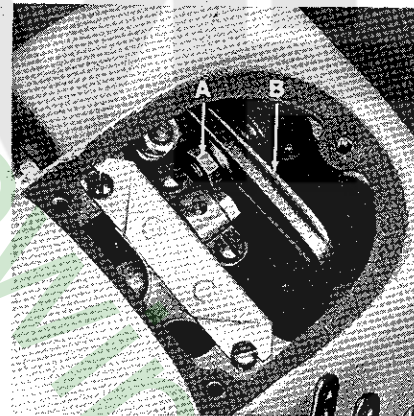


FIGURE 17

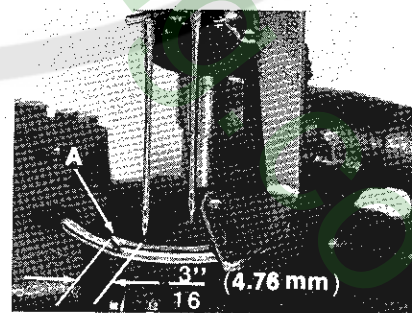
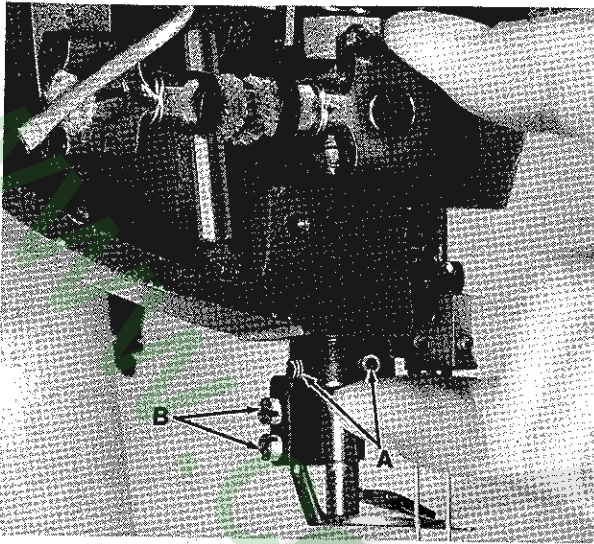


FIGURE 18

When the spreader is at the extreme left end of its travel, the point of the thread carrying notch (A, Fig. 18) should extend  $\frac{3}{16}$  inch (4.76 mm) to the left of the centerline of the left needle. Loosen screws (A, Fig. 19) to position spreader holder to the required dimension.

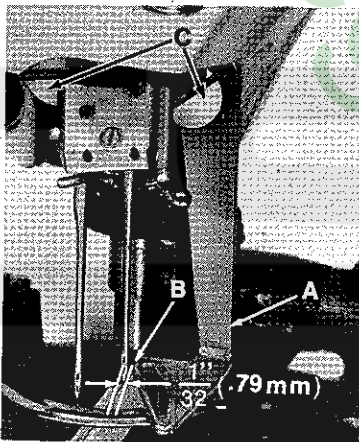




**FIGURE 19**

Retighten screws (A, Fig. 19) while pushing down on the spreader holder carrier and up on the spreader holder.

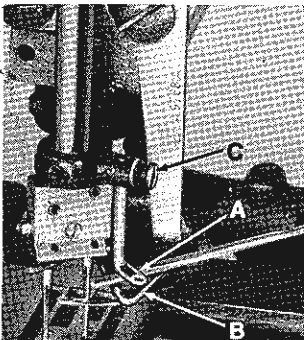
### SETTING THE SPREADER THREAD GUIDE AND EYELET



**FIGURE 20**

Stationary spreader thread guide (A, Fig. 20) should be located approximately 1/32 inch (.79 mm) from right needle at point (B). Adjustment is made by loosening screws (C) and moving the guide as required. Retighten screws securely after adjustment.

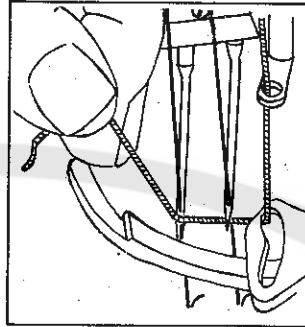
**NOTE:** Set the stationary spreader thread guide as high as its clamp screws will allow so that clearance to the spreader is maintained.



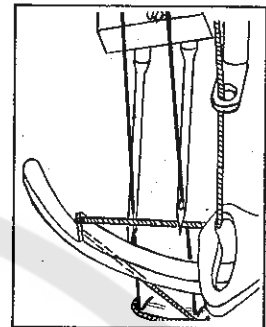
**FIGURE 21**

Spreader thread eyelet (A, Fig. 21) should be set so that the shank of a Type 147 needle, .080 inch (2.00 mm) barely passes between the under surface of the spreader eyelet and the top of the stationary spreader thread guide (B), when needle bar is in its lowest position. Turn eyelet (A) so its eye is directly over the front end of the slot in stationary guide (B). Screw (C) secures eyelet (A).

### SPREADER THREADING AND TENSION

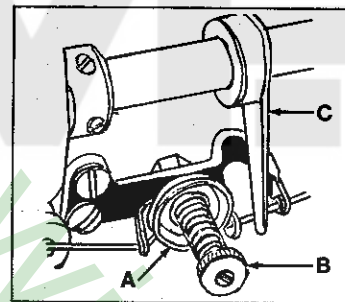


**FIGURE 22**



**FIGURE 23**

Draw the spreader thread into the machine as shown in (Fig. 22). Hold the thread between the thumb and index finger of the left hand drawing it down to the left and slightly behind the right needle while rotating the handwheel. Be sure the spreader point picks up the thread. The left needle must enter the loop of the spreader thread while the right needle passes in front of the thread (Fig. 23).



**FIGURE 24**

Spreader thread is controlled by the tension discs (A, Fig. 24) mounted on the back side of the head. Tightening or loosening the nut (B) adjusts the tension. Approximately 1/2 to 1 ounce (14.18 or 28.35 gr.) of tension is required. The strike off lever (C) should barely contact the thread in its lowest position.

### THREAD TENSIONS

The tension on the needle threads should be set to produce uniform stitches on the bottom side of the fabric. The looper thread tensions should be approximately one fourth the tension applied to the needle threads.

## SUGGESTED SPARE PARTS INVENTORY

The parts listed below are intended to assist you in setting up the initial inventory of spare parts for machine Style 51500 BV-16.

Amt. Req.	Part No.	Description	Amt. Req.	Part No.	Description
1	A9770 R-16	Presser Foot	1	22834	Needle Guard Height Adjusting Screw
1	91	Screw for A9770 R-16	1	A9771-16	Looper, front
1	51405 AD-16	Feed Dog	1	A9772	Looper, rear, marked "UL"
1	22528	Screw for 51405 AD-16	2	73	Screw for loopers
1	A9820-16	Throat Plate	1	52945 M	Spreader
2	87	Screw for A9820-16	2	77 A	Screw for 52945 M
1	31117	Needle Bar	1	A9768 A	Spreader Thread Guide
1	A9819-16	Needle Bar Head	2	22542	Screw for A9768 A
1	A9819 A	Thread Guide Wire	1	52842 A	Needle Bar Spreader Thread Eyelet Support
1	28	Screw for A9819 A	1	22743	Screw for 52842 A
2	22801	Screw for needles	1	41076 D	Spreader Thread Eyelet
1	A9775 A	Needle Guard	1	73 A	Screw for 41076 D
1	22585 B	Screw for A9775 A			
1	51225 W	Washer for 22585 B			

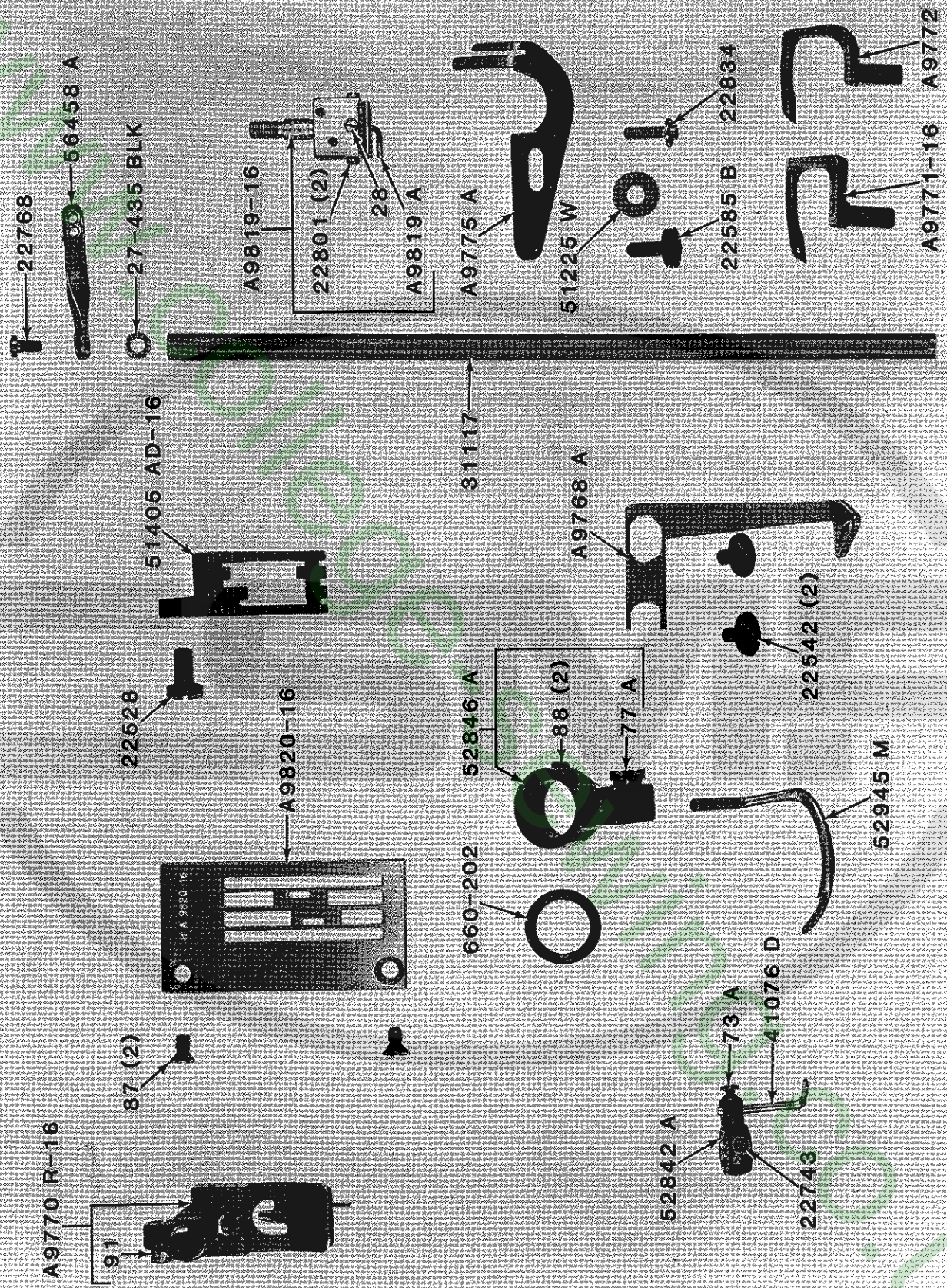
The following is a numerical list of parts used in this machine. Quantities, part numbers and descriptions are given. Following the parts list are photographs of some of the major parts.

Amt.	Part No.	Description	Amt.	Part No.	Description
1	8	Feed Rocker Shaft	1	643-127 Blk.	Gasket
6	18	Nut for 51240 D, 52841 A, 52952 B, 55244 G, 56341 M, 57840	1	660-136	Feed Crank Link Oil Tube
3	20	Washer for 51282 AH	3	660-202	Oil Ring for 52846 A, 52849 C, 52921 B
1	20	Washer for 56341 M	1	660-207	Oil Ring for presser foot lever
1	20	Washer for 52758	1	660-614	Temper Load Ring
1	20	Washer for 51236 G	2	660-625	Oil Seal Ring for 56350 D, 56350 E
2	20	Washer for 52841 A	2	666-65	Oil Wick for looper rocker shaft
1	HA20 A	Washer for 52952 B	1	666-99	Oil Wick for spreader rocker shaft
1	CL21	Oil Wick for 51240 D	2	666-111	Oil Wick for feed rocker shaft
2	25 S	Screw for 51282 AJ	2	666-114	Oil Wick for right mainshaft bearing
1	27-435 Blk.	Needle Bar Eyelet Washer	2	666-118	Oil Wick for left mainshaft bearing
1	28	Screw for 52804 A	2	666-179	Wedge Pin for 666-111
3	40-46	Washer for 53782 B	1	666-201	Felt Plug for 51294 U
2	50-216 Blk.	Pin for 51457 A	1	666-209	Felt Disc for 51294 U
1	50-648 Blk.	Oil Sight Gauge	2	719	Screw for 56350 D
1	77	Screw for 51236 A	1	6042 A	Washer for 55235 D
1	77	Screw for 51054	1	A9416	Mainshaft
2	80	Screw for 51280 A	1	A9769	Looper Rocker Assembly
3	80	Screw for cloth plate	1	258 A	Lock Nut
1	82	Screw for 51236 G	1	A9769 A	Looper Rocker
2	90	Screw for 56382 AC	1	15465 F	Looper Rocker Cone
1	90	Screw for 52894 AB	2	88	Screw
2	93	Screw for BB21375 AH	1	22829	Lock Nut Screw
1	95	Screw for 21270 B	1	51745	Looper Rocker Cone Stud
1	96	Screw for 51244	1	A9774 A	Looper Drive Lever Crank Assembly
1	98	Screw for 51244	2	22559 A	Bearing Cap Screw, lower
2	98 A	Screw for 158 B, 52958 G	2	22559 B	Bearing Cap Screw, upper
10	109	Tension Disc	1	22729	Screw for 51243 C
1	158 B	Looper Thread Eyelet	1	51243 C	Ball Stud Guide
3	269	Nut for 51236 G, 51240 D, 57840	1	A9776	Looper Drive Lever
4	294	Screw for head cover	1	12934 A	Nut for 52848 B
1	294	Screw for 52894 K	1	15037 A	Nut for 52848 C
1	402	Screw for 53783 A	2	15438 B	Tension Disc
2	482	Collar for 8	1	15438 C	Tension Spring
1	531	Screw for 51257 M	1	15438 D	Stud for 22517 C
			1	BB21375 AH	Belt Guard (screw 93)

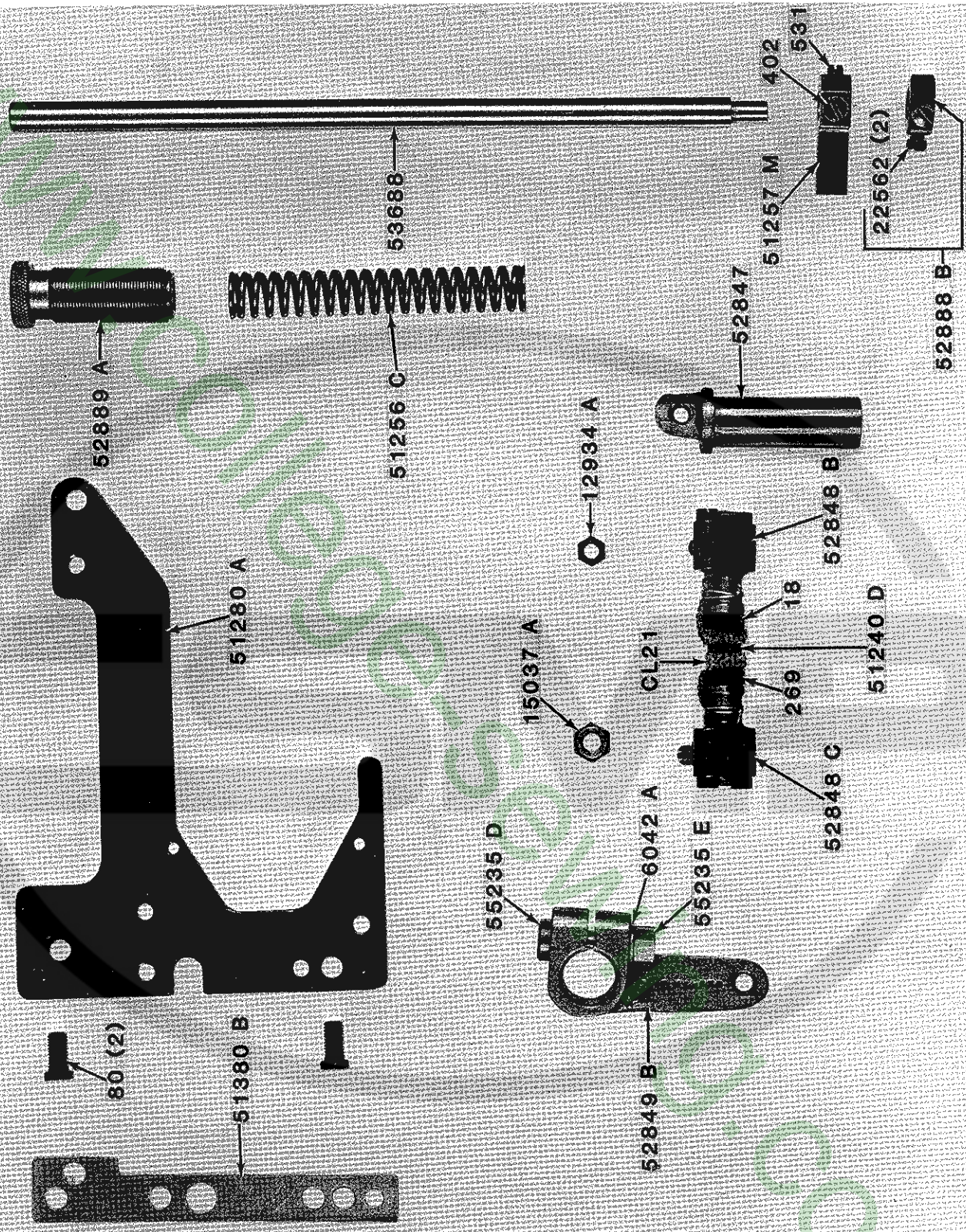
Amt.	Part No.	Description	Amt.	Part No.	Description
1	21657 E	Washer for 22528	1	51054	Taper Pin
1	21657 W	Tension Release Lever Shaft	1	51134	Feed Bar
1	21657 Y	Connection	1	51134 C	Feed Bar Shaft
1	21657-4	Tension Disc Separator	1	51134 P	Felt for 51134 C
4	22513	Screw for 35731 A	1	51134 R	Lubricating Felt Guard
1	22517 C	Spreader Thread Tension Screw, front	1	51144	Looper Rocker Shaft
7	22524	Screw for 53782 B	1	51147	Collar
1	22528	Screw for 51457 A	2	51216 G	Needle Lever Connecting Rod
1	22539 D	Plug Screw	1	51216 N	Washer for 55244 G
1	22539 H	Plug Screw	1	51216 N	Washer for 29066 R
3	22541 B	Screw for 52882 AD	1	51235	Feed Rocker
4	22548	Screw for 52882 AF	1	51235 A	Feed Rocker Arm
1	22557 B	Screw for 53783 L	1	51236 A	Looper Avoid and Feed Lift Link Pin
2	22559 G	Screw for 29066 R	1	51236 E	Feed Crank Link Assembly
2	22559 G	Screw for 52952 B	1	51236 G	Feed Crank Stud
1	22560 B	Screw for 52894 AK	1	51240 D	Spreader Connecting Rod
3	22569 B	Screw for 51493 AG			(nut 18, 269)
3	22569 B	Screw for bearing housing	1	51244	Looper Rocker Frame (screw 96, 98)
18	22571 A	Plug Screw	1	51244 B	Looper Rocker Shaft Arm
2	22571 B	Plug Screw	2	51244 L	Thrust Washer
1	22572 A	Screw for head cover	1	51244 N	Looper Rocker Shaft Collar
2	22585 A	Screw for 53782 B	1	51246	Nut for 51745
1	22586 R	Screw for 51250 D	1	51250 D	Washer for 22586 R
2	22587 H	Screw for 52947 A	1	51250 F	Gasket for 22586 R
1	22706 A	Plug Screw	1	51256 C	Presser Bar Spring
1	22729 A	Screw for 51294 U	1	51257 M	Presser Bar Connection and Guide
1	22733 B	Screw for 52982 D	1	51270 B	Pull-off Wire
1	22758 C	Screw for 53783 A	1	51280 A	Throat Plate Support (screw 80)
3	22760 A	Screw for 51281 T-215	1	51281 T-215	Cloth Plate Cover
1	22768	Screw for 56458 A	1	51281 AC	Cloth Plate Cover Spring
1	22768	Screw for G52758 A	1	51282 AH	Oil Shield, end
1	22768	Screw for 51244 B	1	51282 AJ	Oil Shield, front
1	22801	Screw for mainshaft	1	51283 H	Presser Foot Lifter Lever
2	22839 C	Screw for cloth plate	5	51292 A	Tension Post Ferrule
1	22845 B	Screw for 51281 T-215	5	51292 C	Tension Nut
1	22848	Screw for 52758	5	51292 D	Tension Thread Eyelet
9	22848	Screw for 52982 D	2	51292 F-1	Tension Spring, looper
3	22848	Screw for 51282 AH	1	51292 F-2	Tension Spring, spreader
2	22872	Screw for 52855 A	2	51292 F-5	Tension Spring, needle
1	22889 A	Plug Screw	4	51292 G	Tension Post
2	22889 C	Adapter Plug Screw	1	51294 U	Oil Siphon Assembly
1	22889 D	Adapter Plug Screw	1	51294 Y	Oil Tube Connection
1	29066 R	Needle Lever Connecting Rod Upper	1	51301 D	Cloth Plate
		Ball Joint Assembly	1	51380 B	Throat Plate Support Shim
2	22559 G	Screw	1	51382 A	Gasket for 53782 B
1	29126 CR	Spreader Drive Eccentric Assembly	1	51423 B	Take-up
2	95	Screw	1	51457 A	Cast-off Plate (screw 22528)
1	660-246	Retaining Ring	1	51459 A	Thread Guide
1	52951 B	Retaining Washer	4	51491 C	Thread Lead-in Guide
1	29348 AF	Needle Lever Assembly	1	51492	Spreader Thread Tension Post
1	77	Screw	1	51493 D	Oil Pump Driving Shaft
4	660-215	Retaining Ring	2	51493 E	Driving Shaft Gear
1	22564	Screw	1	51493 BP	Pump Driving Gear
1	51254 K	Needle Bar Connection	1	51493 BQ	Pump Driven Gear
2	52336 A	Link Pin	1	51493 AG	Pump Housing
1	56315 A	Needle Lever	1	51493 AH	Pump Housing Cover
1	56350 D	Needle Lever Stud	1	51493 BK	Lint Filter Screen
1	56354 D	Needle Bar Link	2	51959 B	Tension Disc
1	29476 DV	Looper Avoid Eccentric Assembly	1	51959 D	Tension Nut
1	29476 DV	Feed Lift Eccentric Assembly	1	51959 K	Tension Spring
1	22894 D	Screw	1	52758	Frame Eyelet (screw 22848)
1	29476 GZ	Crankshaft Assembly, .990 inch	1	G52758 A	Needle Lever Eyelet (screw 22768)
		(25.15 mm) throw	1	52794 G	Feed Lifter and Looper Avoid
28	51216 M	Needle Bearing			Eccentric Oil Tube
4	35178 D	Spring for 666-65, 666-114	1	52804 A	Cast-off Wire (screw 28)
1	35582 B	Thread Guide	1	52841 A	Looper Connecting Rod
2	35731 A	Presser Bar Connection Guide Plate			Ball Joint, left (nut 18, washer 20)
		(screw 22513)	1	52846 A	Spreader Holder
3	35772 H	Washer for 51281 T-215	1	52847	Spreader Holder Carrier and Lower
-	41355 U	Shim for looper drive lever			Presser Bar Bushing
		(as required)	1	52848 B	Spreader Connecting Rod Ball Joint,
1	41394 A	Gasket for 22733 B			front
3	43266	Nut for 51292 G			

Amt.	Part No.	Description	Amt.	Part No.	Description
1	52848 C	Spreader Connecting Rod Ball Joint, rear	1	52952 C	Spreader Rocker Shaft Lever
1	52849	Spreader Rocker Shaft	1	52954 B	Bushing for bed
1	52849 B	Spreader Rocker Shaft Arm	1	52958 G	Eyelet (screw 98 A)
1	52849 C	Spreader Rocker Shaft Oil Seal Collar	1	52982 D	Oil Reservoir Back Cover (screw 22733 B, 22848)
1	52855 A	Spreader Thread Pull-off Eyelet (screw 22872)	1	52982 E	Gasket for 52982 D
1	52855 G	Spreader Thread Pull-off Arm	1	52994 U	Horizontal Oil Tube
1	52882 P	Gasket for 52882 AD	1	52994 V	Oil Tube Clamp
1	52882 R	Head Cover	1	53688	Presser Bar
1	52882 S	Head Cover Gasket	1	53782 B	Oil Reservoir Top Cover (screw 22524, 22585 A)
1	52882 U	Gasket for 52882 AF	1	53783 A	Lifter Lever Link (screw 402, 22758 C)
1	52882 AD	Chamber Cover (screw 22541 B)	1	53783 L	Presser Foot Lifter Lever Crank
1	52882 AF	Crank Chamber Cover (screw 22548)	1	53783 N	Presser Foot Lifter Lever, Internal
1	52883 S	Presser Foot Lifter Lever Bell Crank Spring	1	55235 D	Screw for 52849 B
1	52888 B	Presser Bar Stop Collar	1	55235 E	Nut for 55235 D
1	52889 A	Presser Spring Regulator	1	55244 G	Looper Rocker Shaft Collar Stud
1	52894 K	Oil Tube Assembly	1	56341 M	Looper Connecting Rod Section and Ball Joint Assembly, right
1	52894 AB	Oil Tube Holder	1	56350 E	Needle Lever Thrust Collar
1	52894 AK	Oil Tube for looper rocker and left ball joint	2	56350 F	Compression Cup
2	52916	Connecting Rod	1	56382 X	Tension Post Support
1	52921 B	Pulley	1	56382 AC	Needle Lever Oiler and Baffle Plate (screw 90)
1	52942 A	Looper Drive Lever Rocker Shaft	1	56383 AB	Presser Foot Lifter Lever Connecting Rod
1	52942 R	Looper Lever Stud	1	56390 E	Crankshaft Bearing Housing Gasket
1	52942 Y	Looper Rocker Shaft Synchronizing Stud	1	56458 A	Needle Bar Eyelet
1	52947 A	Counterweight (screw 22587 H)	1	57840	Looper Connecting Rod
2	52951 C	Spacing Washer	1	99680	Guard for needle lever eyelet
1	52952 B	Spreader Connecting Rod Ball Joint, upper			

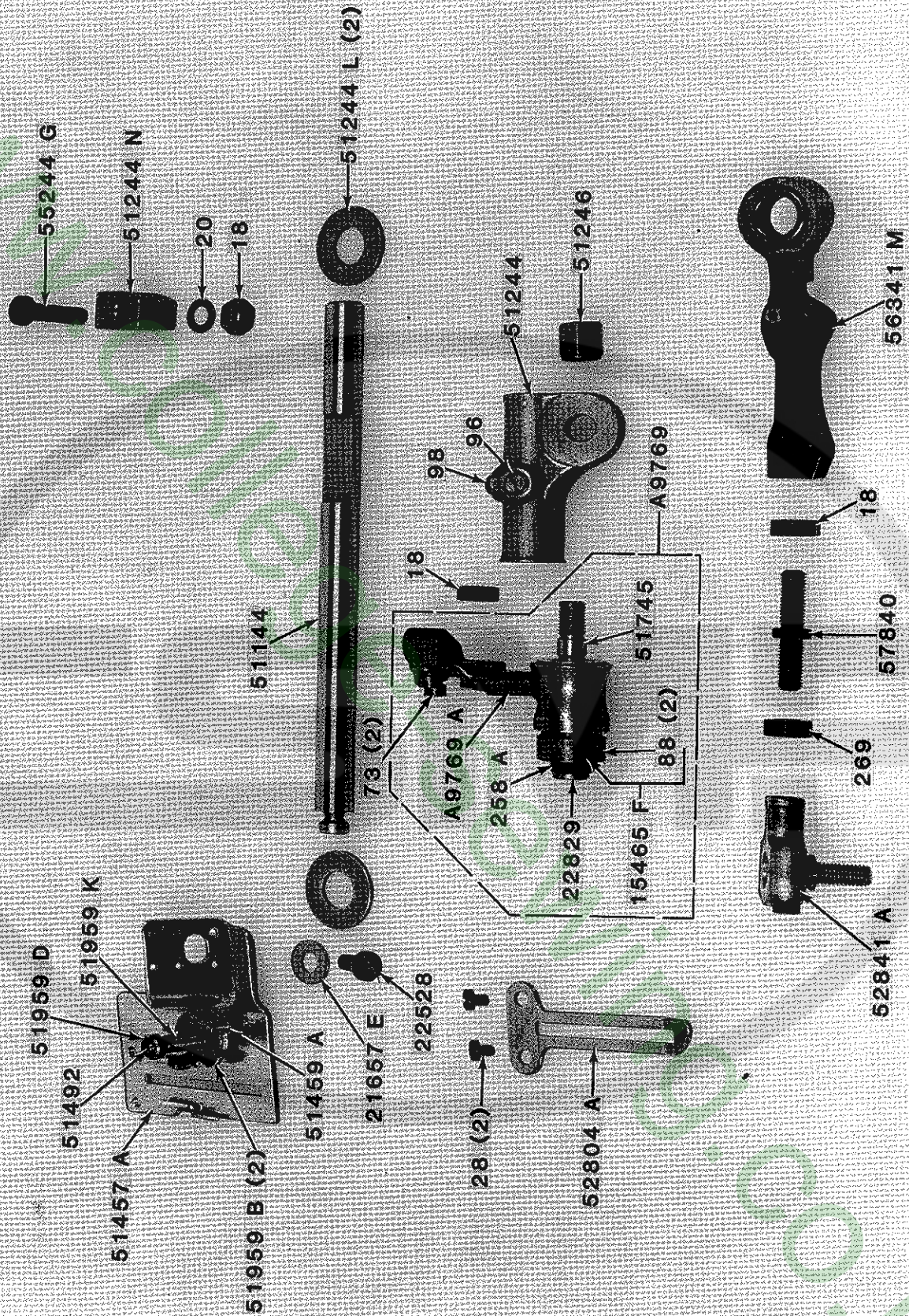
# FEED, FOOT, THROAT PLATE AND STITCH FORMING PARTS



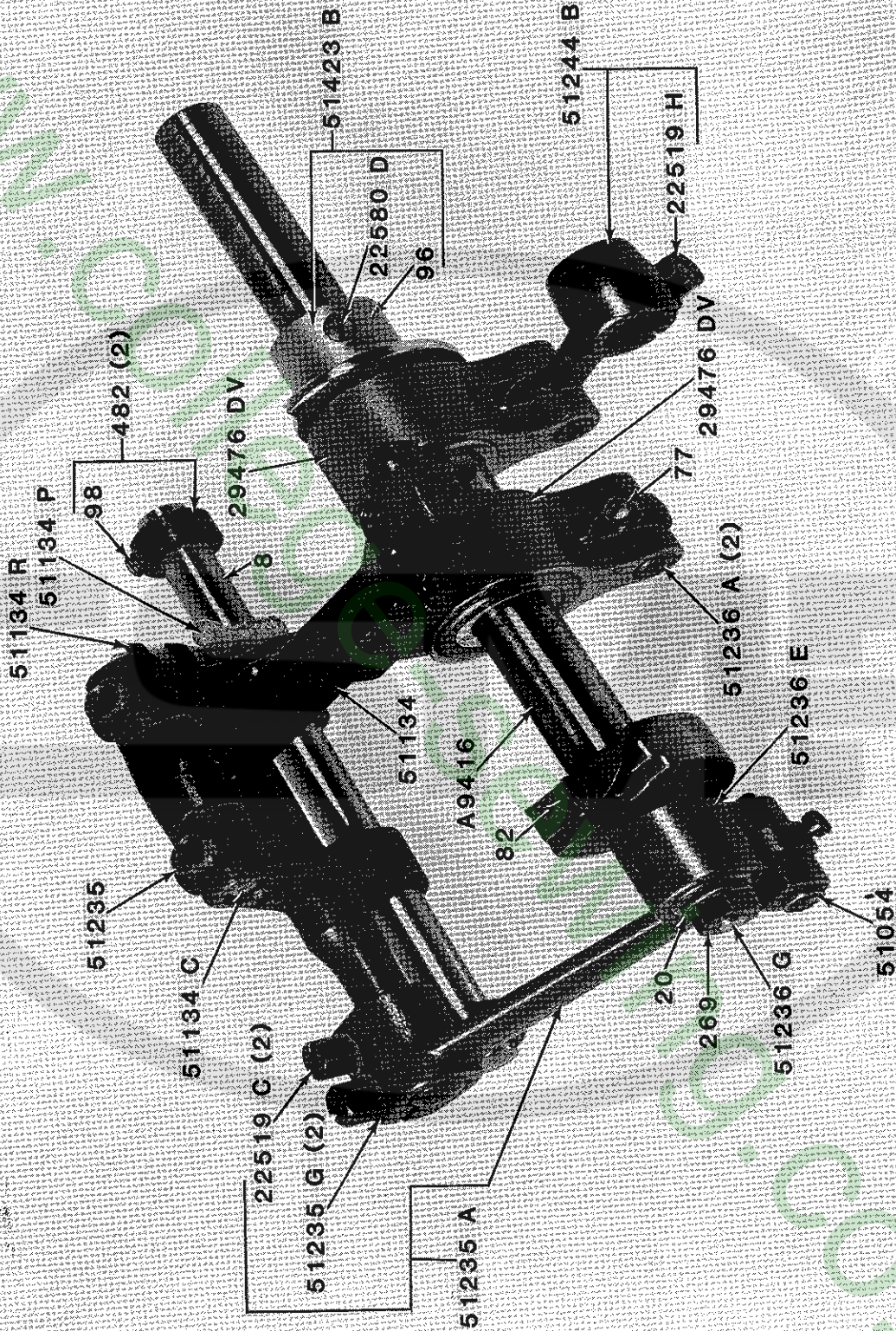
# THROAT PLATE SUPPORT, SPREADER DRIVE AND PRESSER BAR PARTS



# LOOPER ROCKER, CONNECTING ROD ASSEMBLY AND CAST OFF PLATE

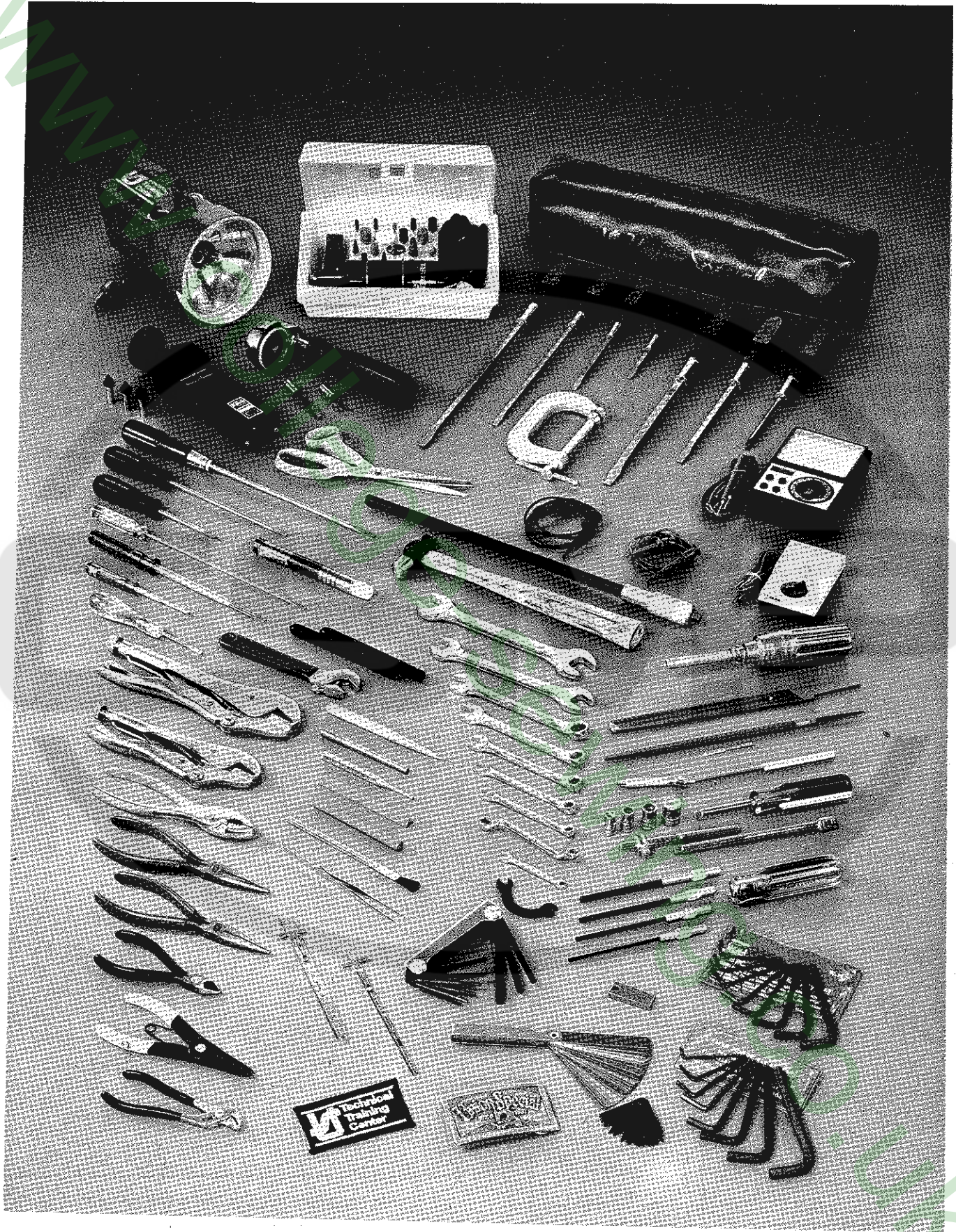


# FRONT MAIN SHAFT AND FEED DRIVE MECHANISM



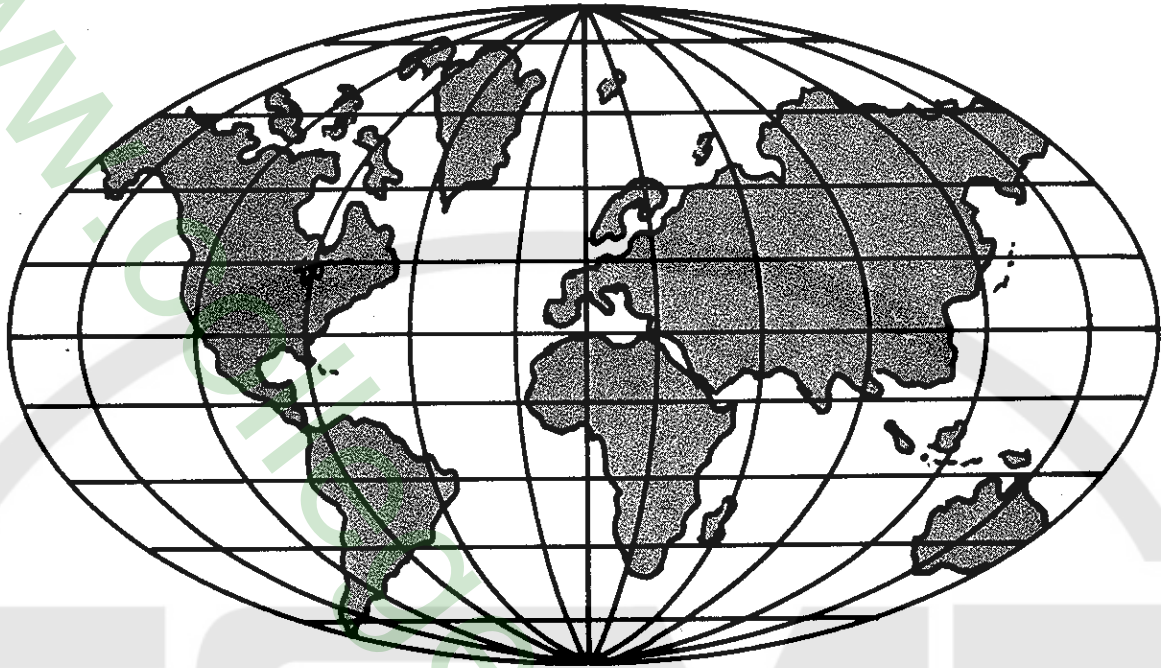






# Tools & Gauges

Description	Order Number	Description	Order Number
<b>KITS:</b>			
Floor Mechanics Tool Kit includes TTC Nos. 4, 5, 10-13, 15-20, 22, 23, 27, 28, 30, 33, 35, 36, 37-42, 48, 57, 58, 72, 73	TTC-1		
Traveling Mechanics Tool Kit same as TTC-1 plus Nos. 7, 43, 44, 49-56	TTC-2		
<b>ALLEN WRENCHES:</b>			
Screwdriver handle and 4 Allen Bits			
Sizes $\frac{3}{32}$ " , $\frac{1}{8}$ " , $\frac{5}{32}$ " , $\frac{3}{16}$ "	TTC-4		
Set Standard 'L' shape Allen Wrenches	TTC-57		
Set Metric 'L' shape Allen Wrenches	TTC-8		
Allen Cluster	TTC-62		
<b>BAGS:</b>			
Union Special Tool Pouch	TTC-30		
<b>BRASS ROD:</b>			
4 x $\frac{1}{16}$ "	TTC-19		
<b>BRUSH:</b>			
Cleaning brush 6"	TTC-23		
<b>BUCKLE:</b>			
Union Special metal belt buckle	TTC-31		
<b>CLAMP:</b>			
C-Clamp 6"	TTC-53		
<b>CUTTER:</b>			
Side cutters 5"	TTC-50		
<b>EMBLEMS:</b>			
TTC emblem for coat	TTC-64		
<b>FILES:</b>			
Round 8"	TTC-55		
Flat 8"	TTC-56		
Handles for files (not shown)	TTC-77		
Diamond file for lockstitch needle guards	TTC-60		
<b>FLASHLIGHT:</b>			
Pocket flashlight with clip	TTC-76		
<b>GAUGES:</b>			
Feeler or thickness gauge, .001 thru .015	TTC-22		
Looper Gauges set of 10 sizes: $\frac{1}{16}$ " , $\frac{3}{32}$ " , $\frac{1}{4}$ " , $\frac{5}{16}$ " , $\frac{3}{8}$ " , $\frac{7}{16}$ " , $\frac{1}{2}$ " , $\frac{5}{8}$ " , $\frac{3}{4}$ " , $\frac{7}{8}$ "	TTC-33		
Synchronizing gauge for flatbed machines (not shown)	TTC-34		
$\frac{4}{16}$ " gauge for flatbed machines (not shown)	TTC-35		
Needle height gauge for 39800 machines	TTC-61		
Spreader height gauge for 52800, 52900, 57800 and 57900 machines (not shown)	TTC-68		
<b>GRINDER:</b>			
Handee grinder kit	TTC-74		
<b>HAMMER:</b>			
4 oz. ball peen hammer	TTC-38		
<b>MAGNET:</b>			
Pocket magnet 8"	TTC-10		
<b>PLIERS:</b>			
Slip joint pliers 6"	TTC-12		
Needle nose pliers 6" (serrated jaws)	TTC-13		
Needle nose pliers 6" (smooth jaw)	TTC-49		
Plastic grips for pliers	TTC-14		
Snap ring pliers	TTC-69		
Grooved pliers HL-14P	TTC-84		
<b>PUNCH:</b>			
Center punch 4"	TTC-54		
Drift punch	TTC-82		
<b>SANDING CLOTH:</b>			
Emery cloth (not shown)	TTC-78		
Crocus cloth (not shown)	TTC-79		
Roll emery cord (not shown)	TTC-80		
<b>SCALE:</b>			
Metal scale $\frac{1}{2}$ " x 6"		TTC-15	
Metal scale $\frac{1}{2}$ " x 6", inches and metric		TTC-86	
Metal scale $\frac{1}{4}$ " x 6"		TTC-66	
<b>SCISSORS:</b>			
8"		TTC-32	
<b>SCREWDRIVERS:</b>			
Set various size wood handled screwdrivers: 4", 10", 2-8", 6", 14", 12"		TTC-5	
10" x $\frac{3}{16}$ " blade		TTC-24	
8" x $\frac{3}{16}$ " blade, plastic handle Stanley		TTC-73	
6" x $\frac{3}{16}$ " blade		TTC-25	
3" x $\frac{3}{16}$ " blade		TTC-26	
2" x $\frac{1}{8}$ " blade		TTC-27	
8" x $\frac{1}{8}$ " blade		TTC-28	
Quickwedge screw starter 5"		TTC-11	
Quickwedge screw starter 3"		TTC-65	
<b>SOCKETS:</b>			
T-Handle, 6" extension $\frac{3}{32}$ " , $\frac{1}{16}$ " , $\frac{3}{16}$ " and $\frac{1}{2}$ " sockets all $\frac{1}{4}$ " drive		TTC-37	
$\frac{1}{2}$ " socket, $\frac{1}{4}$ " drive		TTC-46	
$\frac{3}{16}$ " socket, $\frac{1}{4}$ " drive		TTC-47	
Screwdriver handle for sockets $\frac{1}{4}$ " drive		TTC-48	
T-Handle $\frac{1}{4}$ " drive		TTC-63	
<b>STONES:</b>			
Triangle India Stone 4"		TTC-20	
Round India Stone 4"		TTC-21	
<b>TACHOMETER:</b>			
Handheld digital tach 1-20,000 RPM		TTC-67	
<b>TEST LEADS:</b>			
Red Pomona type clip		TTC-70	
Black Pomona type clip		TTC-71	
<b>TIMING LIGHT:</b>			
Strobe light		TTC-75	
<b>TWEEZERS:</b>			
Sharp point		TTC-16	
<b>VICE GRIPS:</b>			
Small 7"		TTC-51	
Large 10"		TTC-52	
<b>VOLT-OHM METERS:</b>			
Pocket VOM Multitester		TTC-6	
Large VOM Multitester		TTC-7	
Case—small (not shown)		TTC-8	
Case—large (not shown)		TTC-9	
<b>WRENCHES:</b>			
Needle wrench $\frac{3}{32}$ " open end, curved for needle and looper nuts		TTC-17	
Looper avoid wrench for classes 35800 and 36200. (not shown)		TTC-85	
$\frac{3}{32}$ " x $\frac{1}{4}$ " curved box end		TTC-18	
$\frac{1}{2}$ " open and box end		TTC-39	
$\frac{3}{8}$ " open and box end		TTC-40	
$\frac{1}{2}$ " open and box end		TTC-41	
$\frac{1}{4}$ " open and box end		TTC-81	
$\frac{1}{16}$ " open and box end		TTC-42	
$\frac{5}{8}$ " x $\frac{3}{16}$ " open end		TTC-43	
$1\frac{1}{16}$ " x $\frac{3}{4}$ " open end		TTC-44	
$\frac{3}{16}$ " x $\frac{7}{32}$ " open end		TTC-45	
$\frac{1}{4}$ " x $\frac{7}{32}$ " open end		TTC-72	
6" adjustable		TTC-36	
8" adjustable		TTC-59	
Adjustable torque wrench 0-75 in. lb. dial indicator with screwdriver bit & $\frac{1}{4}$ " drive adapter		TTC-3	
Rod wrench for use with above torque wrench on flatbed machines		TTC-29	
Adjustable torque wrench 0-36 in. lb. with bits		TTC-83	



## WORLDWIDE SALES AND SERVICE

UNION SPECIAL maintains sales and service facilities throughout the world. These offices will aid you in the selection of the right sewing equipment for your particular operation. UNION SPECIAL representatives and servicemen are factory trained and are able to serve your needs promptly and efficiently. Whatever your location, there is a UNION SPECIAL representative to serve you. Check with him today.

It is important to remember that LEWIS AND COLUMBIA machines are also products of UNION SPECIAL, thus offering the industry the most complete line of the Finest Quality sewing machines.

Norcross, GA  
Chicago, IL  
Dallas, TX  
Commerce, CA  
New York, NY  
Philadelphia, PA  
Woburn, MA  
Opa-Locka, FL  
Montreal, Quebec  
Toronto, Ontario  
Catano, Puerto Rico  
Brussels, Belgium  
Leicester, England  
Paris, France  
Stuttgart, W. Germany  
Hong Kong

Other Representatives throughout  
all parts of the world

---

 **Union Special**<sup>®</sup>  
Finest Quality Industrial Sewing Equipment

---