



**SINGER**

**411U157A, 157J, 157K, 557A, 557J,  
557K**

# ILLUSTRATED PARTS LIST

FOR

# SINGER®

MACHINES

411U 157A  
157J  
157K  
557A  
557J  
557K

# CONTENTS

FACE PLATE, ARM SIDE COVER .....	1
TAKE-UP LEVER, ARM SHAFT, MACHINE PULLEY .....	2
NEEDLE BAR, NEEDLE BAR ROCK FRAME .....	3
PRESSER BAR, PRESSER BAR LIFTER .....	4
FEED MECHANISM (FEED ROCK SHAFT DRIVING FRAME) .....	5
FEED REGULATING DIAL, FEED REVERSE LEVER .....	6
FEED BAR, FEED DRIVING ROCK SHAFT .....	7
HOOK DRIVING SHAFT,HOOK DRIVING SHAFT CONNECTION BELT PULLEY .....	8
HOOK SADDLE (RIGHT), HOOK .....	9
LUBRICATION (PLUNGER PUMP) .....	11
LUBRICATION (OIL RESERVOIR) .....	12
LUBRICATION (BED AREA) .....	13
TENSION .....	14
BOBBIN WINDER .....	15
THREAD TRIMMER 1 .....	16
THREAD TRIMMER 2 .....	17
TENSION RELEASING .....	18
BACK TACK MECHANISM .....	19
BACK TACK SWITCH .....	20
GAUGE PARTS .....	21
ACCESSORIES AND ATTACHMENTS 1 .....	22
ACCESSORIES AND ATTACHMENTS 2 .....	23
ACCESSORIES AND ATTACHMENTS 3 .....	24
PARTS AVAILABLE AT EXTRA CHARGE .....	25

# FACE PLATE, ARM SIDE COVER

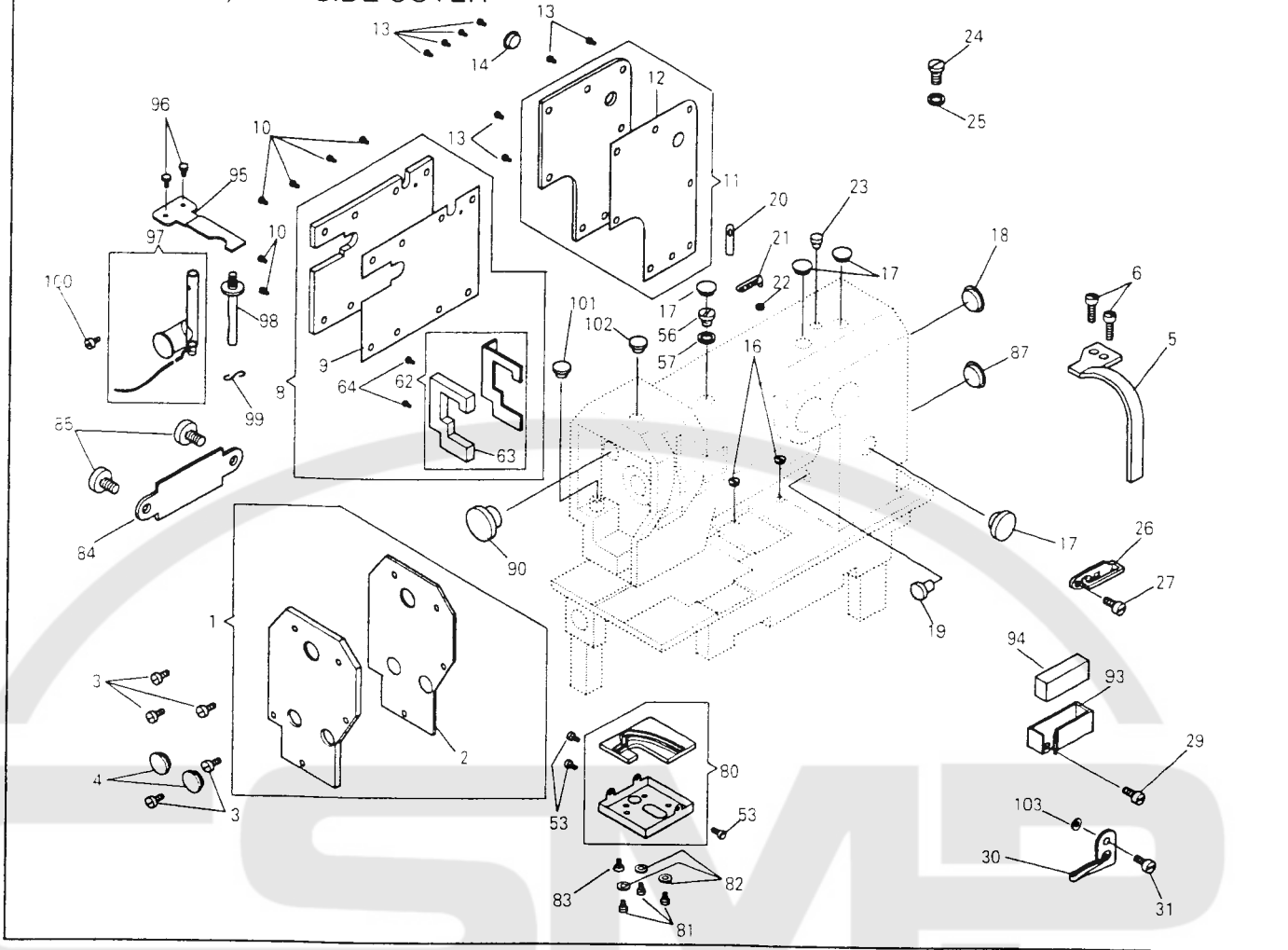

NO	PART NO.	157A	157J	157K	557A	557J	557K	QTY	DESCRIPTION
1	554890-467	*	*	*	*	*	*	1	FACE PLATE AND FACE PLATE PACKING COMP.
2	554309	*	*	*	*	*	*	1	FACE PLATE PACKING
3	544217-052	*	*	*	*	*	*	5	FACE PLATE SCREW
4	368063	*	*	*	*	*	*	2	FACE PLATE PLUG
5	552410-467	*	*	*	*	*	*	1	TAKE-UP LEVER GUARD
5	552823-467	*	*	*	*	*	*	1	TAKE-UP LEVER GUARD
6	544217-052	*	*	*	*	*	*	2	TAKE-UP LEVER GUARD SCREW
8	554450	*	*	*	*	*	*	1	ARM SIDE COVER (SMALL) AND ARM SIDE COVER (SMALL) GASKET COMP.
9	554308	*	*	*	*	*	*	1	ARM SIDE COVER (SMALL) GASKET
10	544217-052	*	*	*	*	*	*	6	ARM SIDE COVER (SMALL) SCREW
11	552867	*	*	*	*	*	*	1	ARM SIDE COVER (LARGE) AND ARM SIDE COVER (LARGE) GASKET COMP.
12	554310	*	*	*	*	*	*	1	ARM SIDE COVER (LARGE) PACKING
13	544217-052	*	*	*	*	*	*	8	ARM SIDE COVER (LARGE) SCREW
13	544217-052	*	*	*	*	*	*	7	ARM SIDE COVER (LARGE) SCREW
13	544217-004	*	*	*	*	*	*	1	ARM SIDE COVER (LARGE) SCREW
14	368063-392	*	*	*	*	*	*	1	ARM SIDE COVER (LARGE) HOLE PLUG
16	549230	*	*	*	*	*	*	2	BED OIL HOLE PLUG
17	544875-392	*	*	*	*	*	*	4	ARM HOLE PLUG
18	552835	*	*	*	*	*	*	1	ARM HOLE PLUG (BACK)
19	508283	*	*	*	*	*	*	1	ARM HOLE PLUG (FEED REVERSE LEVER HINGE STUD HOLE)
20	508562	*	*	*	*	*	*	1	THREAD GUIDE STUD
21	411092	*	*	*	*	*	*	1	THREAD RETAINER (4-HOLES)
22	541180	*	*	*	*	*	*	1	THREAD RETAINER (4-HOLES) NUT
23	375014-452	*	*	*	*	*	*	1	ARM HOLE PLUG (SMALL)
24	544212-003	*	*	*	*	*	*	1	EARTH WIRE SCREW
25	543803-003	*	*	*	*	*	*	1	EARTH WIRE SCREW WASHER
26	267316	*	*	*	*	*	*	1	THREAD GUIDE (UPPER)
27	544347	*	*	*	*	*	*	1	THREAD GUIDE (UPPER) SCREW
29	504063-451	*	*	*	*	*	*	1	THREAD GUIDE (MIDDLE) SCREW
30	224040	*	*	*	*	*	*	1	THREAD GUIDE (LOWER)
31	544347	*	*	*	*	*	*	1	THREAD GUIDE (LOWER) SCREW
53	544217-051	*	*	*	*	*	*	3	NEEDLE BAR ROCK FRAME COVER SCREW

NO	PART NO.	157A	157J	157K	557A	557J	557K	QTY	DESCRIPTION
56	545036	*	*	*	*	*	*	1	TAKE-UP LEVER OIL HOLE CAP SCREW
57	545754	*	*	*	*	*	*	1	TAKE-UP LEVER OIL HOLE CAP SCREW
62	554451	*	*	*	*	*	*	1	ARM SIDE COVER (SMALL) OIL GUARD COMP.
63	554686	*	*	*	*	*	*	1	ARM SIDE COVER (SMALL) OIL GUARD OIL SEAL
64	544211-002	*	*	*	*	*	*	2	ARM SIDE COVER (SMALL) OIL GUARD SCREW
80	554876	*	*	*	*	*	*	1	NEEDLE BAR ROCK FRAME COVER PACKING COMP.
81	374497-001	*	*	*	*	*	*	3	NEEDLE BAR ROCK FRAME COVER SCREW
82	548054	*	*	*	*	*	*	3	NEEDLE BAR ROCK FRAME COVER SCREW WASHER
83	374583-002	*	*	*	*	*	*	1	NEEDLE BAR ROCK FRAME COVER SCREW
84	554640	*	*	*	*	*	*	1	ARM SIDE COVER
85	544217-052	*	*	*	*	*	*	2	ARM SIDE COVER SCREW
87	502760	*	*	*	*	*	*	1	ARM HOLE PLUG
90	544886-452	*	*	*	*	*	*	1	(FEED REGULATOR SHAFT HOLE) ARM HOLE PLUG
93	412476	*	*	*	*	*	*	1	THREAD LUBRICATOR OIL PAD HOLDER
94	412479	*	*	*	*	*	*	1	THREAD LUBRICATOR OIL PAD
95	554893	*	*	*	*	*	*	1	THREAD LUBRICATING REGULATOR SPRING
96	544212-051	*	*	*	*	*	*	2	THREAD LUBRICATING REGULATOR SPRING SET SCREW
97	554739	*	*	*	*	*	*	1	THREAD LUBRICATING RESERVOIR COMP.
98	514072	*	*	*	*	*	*	1	THREAD LUBRICATING RESERVOIR STUD
99	554848	*	*	*	*	*	*	1	THREAD LUBRICATING RESERVOIR OIL TUBE RETAINER
100	374119	*	*	*	*	*	*	1	THREAD LUBRICATING RESERVOIR SET SCREW
101	416384-452	*	*	*	*	*	*	1	ARM HOLE PLUG
102	418384-452	*	*	*	*	*	*	1	ARM HOLE PLUG (NEEDLE BAR HOLE)
103	543875-005	*	*	*	*	*	*	1	THREAD GUIDE LOWER SPACER

# TAKE-UP LEVER, ARM SHAFT. MACHINE PULLEY

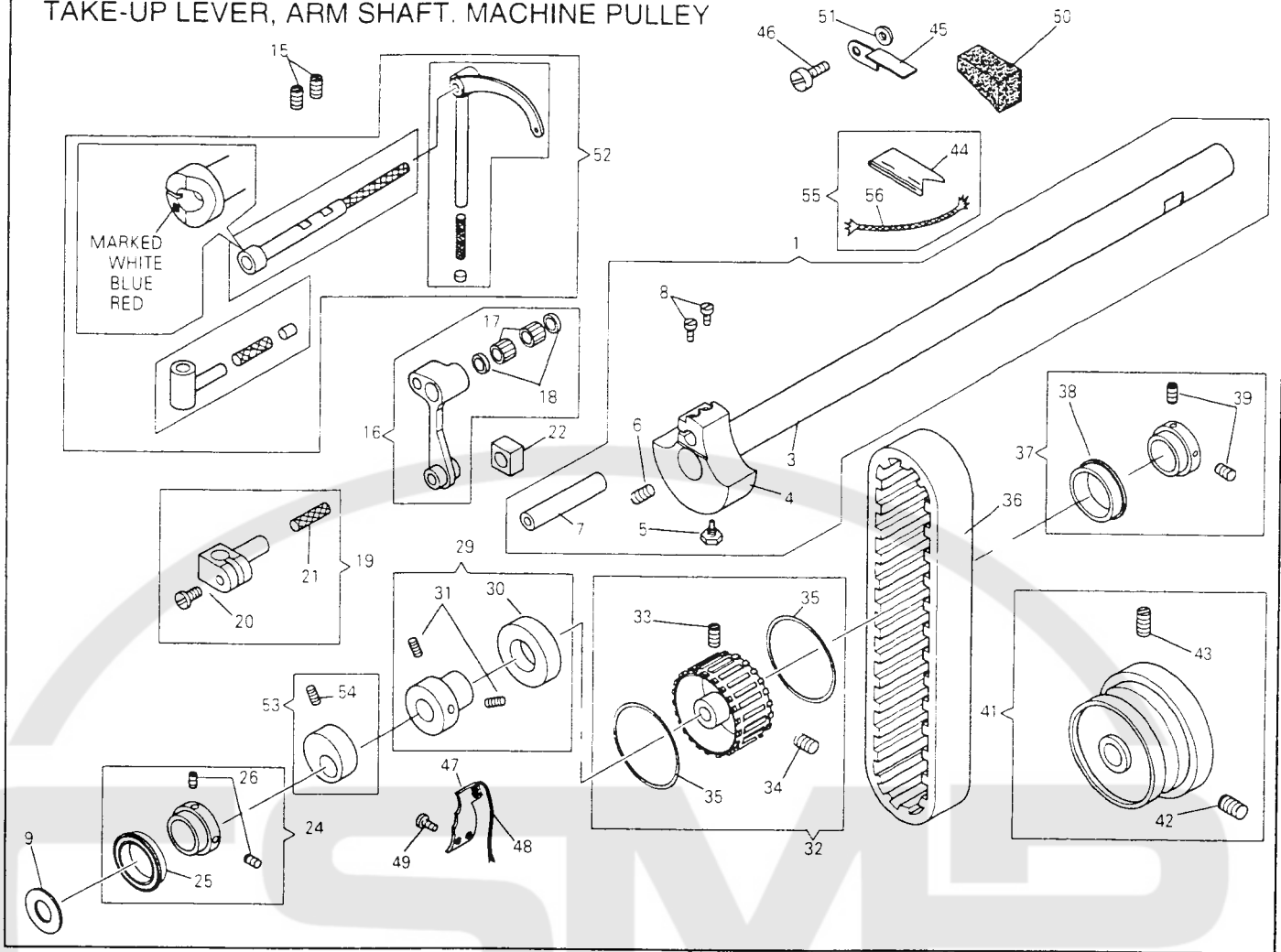

NO	PART NO.	QTY					DESCRIPTION
		157A	157J	157K	557A	557J	
1	554811	*	*	*	-	-	1 ARM SHAFT, NEEDLE BAR CONNECTING LINK STUD COMP
1	554814	-	-	-	*	*	1 ARM SHAFT, NEEDLE BAR CONNECTING LINK STUD COMP
3	554323	*	*	*	*	*	1 ARM SHAFT
4	554813	*	*	*	-	-	1 NEEDLE BAR CRANK
4	554816	-	-	-	*	*	1 NEEDLE BAR CRANK
5	374100	*	*	*	*	*	1 NEEDLE BAR CRANK POSITION SCREW
6	504095	*	*	*	*	*	1 NEEDLE BAR CRANK SET SCREW
7	554693	*	*	*	*	*	1 NEEDLE BAR CONNECTING LINK STUD
8	544448	*	*	*	*	*	2 NEEDLE BAR CONNECTING LINK STUD SET SCREW
9	554325	*	*	*	*	*	1 NEEDLE BAR CRANK FRICTION WASHER
15	544209-006	*	*	*	*	*	2 TAKE-UP LEVER HINGE STUD SET SCREW
16	554327	*	*	*	*	*	1 NEEDLE BAR CONNECTING LINK COMP.
17	502964	*	*	*	*	*	2 NEEDLE BAR CONNECTING LINK BEARING
18	554329	*	*	*	*	*	2 NEEDLE BAR CONNECTING LINK BEARING RETAINING RING
19	552428	*	*	*	*	*	1 NEEDLE BAR CONNECTING STUD COMP.
20	545071	*	*	*	*	*	1 NEEDLE BAR CONNECTING STUD PINCH SCREW
21	202330	*	*	*	*	*	1 NEEDLE BAR CONNECTING STUD OIL WICK
22	552429	*	*	*	*	*	1 NEEDLE BAR CONNECTING STUD SLIDE BLOCK
24	554334	*	*	*	*	*	1 ARM SHAFT BALL BEARING (FRONT) COMP.
25	554335	*	*	*	*	*	1 ARM SHAFT BALL BEARING (FRONT)
26	544209-005	*	*	*	*	*	2 ARM SHAFT BALL BEARING INSIDE COLLAR SET SCREW
29	554834	*	*	*	*	*	1 ARM SHAFT BALL BEARING (MIDDLE) COMP.
30	554835	*	*	*	*	*	1 ARM SHAFT BALL BEARING (MIDDLE)
31	544209-005	*	*	*	*	*	2 ARM SHAFT BALL BEARING INSIDE COLLAR SET SCREW
32	554336	*	*	*	*	*	1 ARM SHAFT CONNECTION BELT PULLEY COMP.
33	544322	*	*	*	*	*	1 ARM SHAFT CONNECTION BELT PULLEY SET SCREW

NO	PART NO.	QTY					DESCRIPTION
		157A	157J	157K	557A	557J	
34	544330	*	*	*	*	*	1 ARM SHAFT CONNECTION BELT PULLEY POSITION SCREW
35	202253	*	*	*	*	*	2 ARM SHAFT CONNECTION BELT PULLEY SPRING FLANGE
36	267161	*	*	*	*	*	1 ARM SHAFT CONNECTION BELT
37	554783	*	*	*	*	*	1 ARM SHAFT BALL BEARING (BACK) COMP
38	554784	*	*	*	*	*	1 ARM SHAFT BALL BEARING (BACK)
39	544209-005	*	*	*	*	*	2 ARM SHAFT BALL BEARING INSIDE COLLAR SET SCREW
41	554656-383	*	*	*	*	*	1 MACHINE PULLEY COMP.
42	141566	*	*	*	*	*	1 MACHINE PULLEY POSITION SCREW
43	141567-833	*	*	*	*	*	1 MACHINE PULLEY SET SCREW
44	552899	*	*	*	*	*	1 TAKE-UP LEVER OIL FELT
45	552898	*	*	*	*	*	1 TAKE-UP LEVER OIL FELT RETAINER
46	544213-052	*	-	-	-	-	1 TAKE-UP LEVER OIL FELT RETAINER SCREW
47	554341	*	*	*	*	*	1 TAKE-UP LEVER OIL GUARD
48	554342	*	*	*	*	*	1 TAKE-UP LEVER OIL GUARD OIL WICK
49	545114	*	*	*	*	*	1 TAKE-UP LEVER OIL GUARD SCREW
50	554720	*	*	*	*	*	1 TAKE-UP LEVER OIL FELT PAD
51	548480	*	*	*	*	*	1 TAKE-UP LEVER OIL FELT RETAINER SPACER
52	554898-000	*	*	*	-	-	1 TAKE-UP LEVER, TAKE-UP LEVER DRIVING STUD, TAKE-UP LEVER HINGE STUD COMP. -001 (MARKED WHITE) -002 (MARKED BLUE) -003 (MARKED RED)
52	554894-000	-	-	-	*	*	1 TAKE-UP LEVER, TAKE-UP LEVER DRIVING STUD, TAKE-UP LEVER HINGE STUD COMP. -001 (MARKED WHITE) -002 (MARKED BLUE) -003 (MARKED RED)
53	554597	-	-	-	*	*	1 ARM SHAFT BALANCER COMP
54	544209-006	-	-	-	*	*	1 ARM SHAFT BALANCER SET SCREW
55	554895	*	*	*	*	*	1 TAKE-UP LEVER OIL FELT OIL WICK COMP.
56	554465-012	*	*	*	*	*	1 TAKE-UP LEVER OIL FELT OIL WICK

# NEEDLE BAR, NEEDLE BAR ROCK FRAME

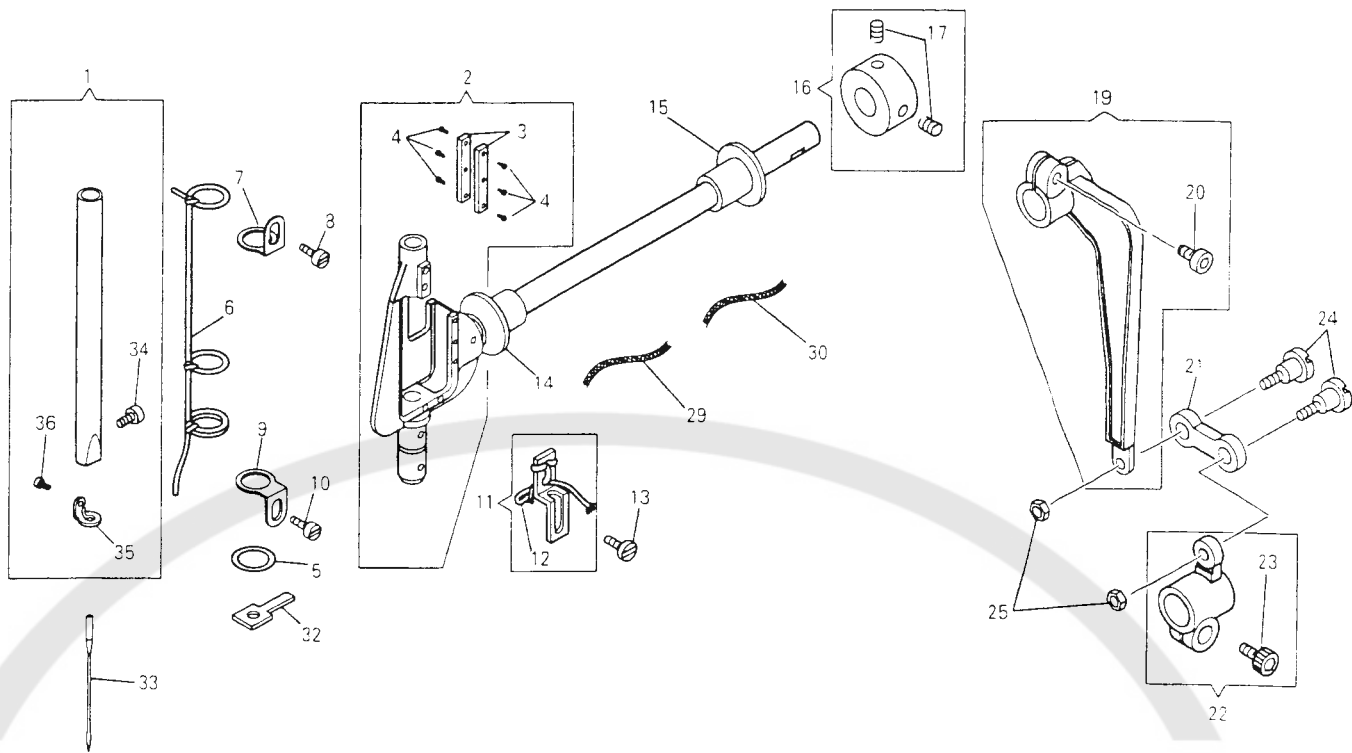

NO.	PART NO.	157A	157J	157K	557A	557J	557K	QTY	DESCRIPTION
1	412148	*	*	*	*	*	*	1	NEEDLE BAR COMP
2	552435	*	*	*	*	*	*	1	NEEDLE BAR ROCK FRAME COMP.
3	554358	*	*	*	*	*	*	2	NEEDLE BAR ROCK FRAME WEAR PLATE
4	544377	*	*	*	*	*	*	6	NEEDLE BAR ROCK FRAME WEAR PLATE SCREW
5	543871-012	*	*	*	*	*	*	1	NEEDLE BAR OIL GUARD
6	554862	*	*	*	*	*	*	1	NEEDLE BAR OIL WICK
7	552440	*	*	*	*	*	*	1	NEEDLE BAR OIL WICK RETAINER (UPPER)
8	544376	*	*	*	*	*	*	1	NEEDLE BAR OIL WICK RETAINER (UPPER) SCREW
9	554531	*	*	*	*	*	*	1	NEEDLE BAR OIL WICK RETAINER (LOWER)
10	544376	*	*	*	*	*	*	1	NEEDLE BAR OIL WICK RETAINER (LOWER) SCREW
11	554343	*	*	*	*	*	*	1	NEEDLE BAR CONNECTING LINK OIL WICK RETAINER COMP.
12	554344	*	*	*	*	*	*	1	NEEDLE BAR CONNECTING LINK OIL WICK
13	544376	*	*	*	*	*	*	1	NEEDLE BAR CONNECTING LINK OIL WICK RETAINER SCREW
14	554635	*	*	*	*	*	*	1	NEEDLE BAR ROCK FRAME ROCK SHAFT BUSHING (FRONT)
15	554636	*	*	*	*	*	*	1	NEEDLE BAR ROCK FRAME ROCK SHAFT BUSHING (BACK)
16	552443	*	*	*	*	*	*	1	NEEDLE BAR ROCK FRAME ROCK SHAFT COLLAR COMP.
17	544204-001	*	*	*	*	*	*	2	NEEDLE BAR ROCK FRAME ROCK SHAFT COLLAR SCREW
19	554638	*	*	*	*	*	*	1	NEEDLE BAR ROCK FRAME ROCK SHAFT CONNECTION COMP.
20	374108-009	*	*	*	*	*	*	1	NEEDLE BAR ROCK FRAME ROCK SHAFT CONNECTION PINCH SCREW
21	552448	*	*	*	*	*	*	1	NEEDLE BAR ROCK FRAME ROCK SHAFT CRANK LINK

NO.	PART NO.	157A	157J	157K	557A	557J	557K	QTY	DESCRIPTION
22	552449	*	*	*	*	*	*	1	NEEDLE BAR ROCK FRAME ROCK SHAFT CRANK COMP.
23	374108-009	*	*	*	*	*	*	1	NEEDLE BAR ROCK FRAME ROCK SHAFT CRANK PINCH SCREW
24	374547	*	*	*	*	*	*	2	NEEDLE BAR ROCK FRAME ROCK SHAFT CRANK LINK HINGE SCREW
25	541168-003	*	*	*	*	*	*	2	NEEDLE BAR ROCK FRAME ROCK SHAFT CRANK LINK HINGE SCREW NUT
29	554465-002	*	*	*	*	*	*	1	NEEDLE BAR ROCK FRAME ROCK SHAFT BUSHING (FRONT) OIL WICK
30	554466-003	*	*	*	*	*	*	1	NEEDLE BAR ROCK FRAME ROCK SHAFT BUSHING (BACK) OIL WICK
32	554858	*	*	*	*	*	*	1	NEEDLE BAR ROCK FRAME FELT
33	N19550-121	*	*	*	*	*	*	1	NEEDLE
34	504112	*	*	*	*	*	*	1	NEEDLE SET SCREW
35	240039	*	*	*	*	*	*	1	NEEDLE BAR THREAD GUIDE
36	545180-452	*	*	*	*	*	*	1	NEEDLE BAR THREAD GUIDE SCREW

# PRESSER BAR, PRESSER BAR LIFTER

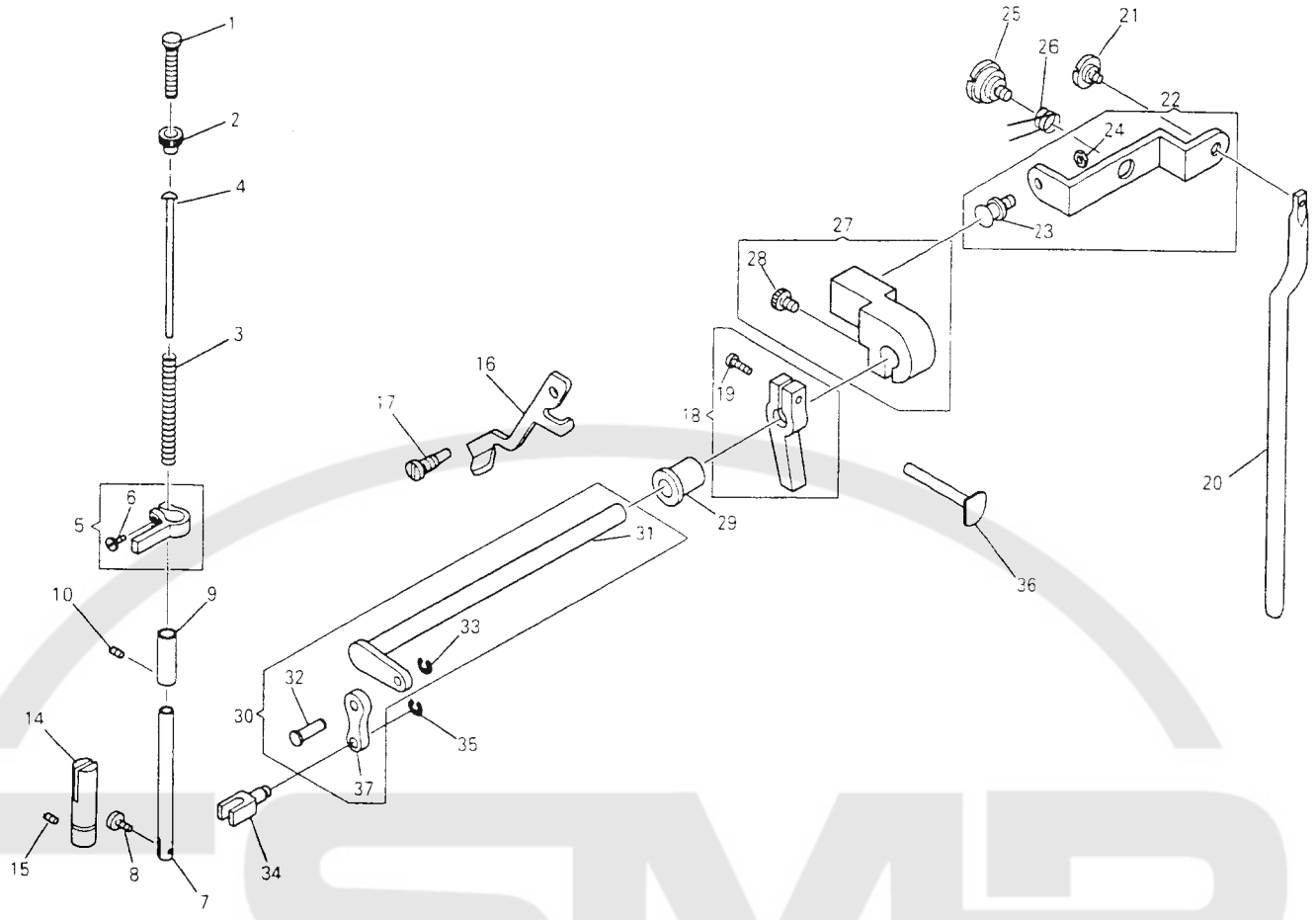

NO.	PART NO.	Y-T-D					DESCRIPTION	
		157A	157J	157K	557A	557J		557K
1	552859	*	*	*	*	*	1	PRESSURE REGULATING SCREW
2	376424-383	*	*	*	*	*	1	PRESSURE REGULATING SCREW LOCK NUT
3	552454	*	*	*	*	*	1	PRESSER BAR SPRING
4	552455	*	*	*	*	*	1	PRESSURE REGULATING SCREW
5	552452	*	*	*	*	*	1	GUIDE ROD
6	545295	*	*	*	*	*	1	PRESSER BAR POSITION GUIDE LEVER COMP.
7	552451	*	*	*	*	*	1	PRESSER BAR
8	500256	*	*	*	*	*	1	PRESSER FOOT SCREW
9	554407	*	*	*	*	*	1	PRESSER BAR BUSHING
10	544205-002	*	*	*	*	*	1	PRESSER BAR BUSHING SET SCREW
14	202337	*	*	*	*	*	1	PRESSER BAR POSITION GUIDE
15	544205-002	*	*	*	*	*	1	PRESSER BAR POSITION GUIDE SET SCREW
16	552456	*	*	*	*	*	1	PRESSER BAR LIFTER
17	374541	*	*	*	*	*	1	PRESSER BAR LIFTER HINGE SCREW
18	552457	*	*	*	*	*	1	PRESSER BAR LIFTER ARM COMP.
18	554904	*	*	*	*	*	1	PRESSER BAR LIFTER ARM COMP.
19	374108-001	*	*	*	*	*	1	PRESSER BAR LIFTER ARM PINCH SCREW
20	552459	*	*	*	*	*	1	KNEE LIFTER ROCK LEVER LIFTING ROD
21	545356	*	*	*	*	*	1	KNEE LIFTER ROCK LEVER LIFTING ROD SCREW
22	552460	*	*	*	*	*	1	KNEE LIFTER ROCK LEVER COMP.
23	552462	*	*	*	*	*	1	KNEE LIFTER ROCK LEVER BALL STUD
24	541166-001	*	*	*	*	*	1	KNEE LIFTER ROCK LEVER BALL STUD
25	374559	*	*	*	*	*	1	LOCK NUT
26	417113	*	*	*	*	*	1	KNEE LIFTER ROCK LEVER SCREW
27	552464	*	*	*	*	*	1	KNEE LIFTER ROCK LEVER SPRING
28	374108-009	*	*	*	*	*	1	KNEE LIFTER SHAFT DRIVING ARM PINCH SCREW

NO.	PART NO.	Y-T-D					DESCRIPTION	
		157A	157J	157K	557A	557J		557K
29	552466	*	*	*	*	*	1	KNEE LIFTER SHAFT BUSHING
30	552467	*	*	*	*	*	1	KNEE LIFTER SHAFT, LINK COMP.
31	552468	*	*	*	*	*	1	KNEE LIFTER SHAFT
32	552472	*	*	*	*	*	1	KNEE LIFTER SHAFT LINK PIN
33	543860-005	*	*	*	*	*	1	KNEE LIFTER SHAFT LINK PIN SNAP RING
34	552473	*	*	*	*	*	1	KNEE LIFTER SHAFT LINK BLOCK
35	543860-005	*	*	*	*	*	1	KNEE LIFTER SHAFT LINK BLOCK SNAP RING
36	552474	*	*	*	*	*	1	TENSION RELEASE LEVER ROD COMP.
37	552471	*	*	*	*	*	1	KNEE LIFTER SHAFT LINK

# FEED MECHANISM (FEED ROCK SHAFT DRIVING FRAME)

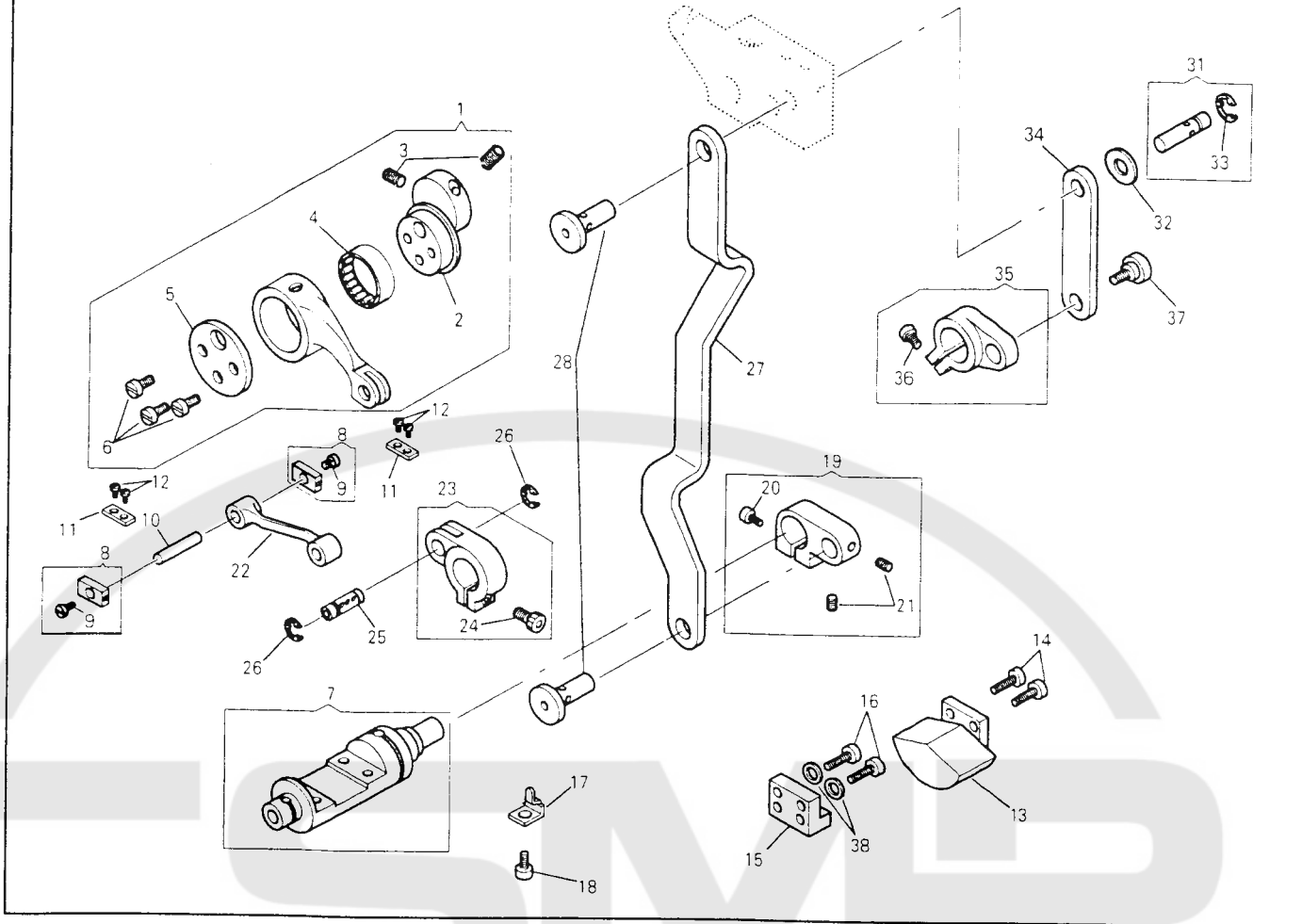

NO.	PART NO.	157A	157J	157K	557A	557J	557K	QTY	DESCRIPTION
		*	*	*	*	*	*		
1	552477	*	*	*	*	*	*	1	FEED DRIVING ECCENTRIC AND FEED DRIVING ECCENTRIC CONNECTION COMP.
2	552478	*	*	*	*	*	*	1	FEED DRIVING ECCENTRIC
3	544209-005	*	*	*	*	*	*	2	FEED DRIVING ECCENTRIC SET SCREW
4	552479	*	*	*	*	*	*	1	FEED DRIVING ECCENTRIC CONNECTION BEARING
5	552481	*	*	*	*	*	*	1	FEED DRIVING ECCENTRIC CONNECTION BEARING RETAINING PLATE
6	544212-051	*	*	*	*	*	*	3	FEED DRIVING ECCENTRIC CONNECTION BEARING RETAINING PLATE SCREW
7	552482	*	*	*	*	*	*	1	FEED ROCK SHAFT DRIVING FRAME COMP.
8	552484	*	*	*	*	*	*	2	FEED ROCK SHAFT DRIVING SLIDE BLOCK COMP.
9	549166	*	*	*	*	*	*	2	FEED ROCK SHAFT DRIVING SLIDE BLOCK SCREW
10	552485	*	*	*	*	*	*	1	FEED ROCK SHAFT DRIVING SLIDE BLOCK STUD
11	552486	*	*	*	*	*	*	2	FEED ROCK SHAFT DRIVING SLIDE BLOCK GUIDE PLATE
12	544212-053	*	*	*	*	*	*	4	FEED ROCK SHAFT DRIVING SLIDE BLOCK GUIDE PLATE SCREW
13	554493	*	*	*	*	*	*	1	FEED ROCK SHAFT DRIVING FRAME BALANCE WEIGHT
14	374106-006	*	*	*	*	*	*	2	FEED ROCK SHAFT DRIVING FRAME BALANCE WEIGHT SCREW
15	554494	*	*	*	*	*	*	1	FEED ROCK SHAFT DRIVING FRAME BALANCE WEIGHT BRACKET
16	374107-003	*	*	*	*	*	*	2	FEED ROCK SHAFT DRIVING FRAME BALANCE WEIGHT BRACKET SCREW
17	552487	*	*	*	*	*	*	1	FEED ROCK SHAFT DRIVING FRAME SUPPORT PLATE
18	544213-051	*	*	*	*	*	*	1	FEED ROCK SHAFT DRIVING FRAME SUPPORT PLATE SCREW

NO.	PART NO.	157A	157J	157K	557A	557J	557K	QTY	DESCRIPTION
		*	*	*	*	*	*		
19	554798	*	*	*	*	*	*	1	FEED ROCK SHAFT DRIVING FRAME LEVER COMP.
20	374107-004	*	*	*	*	*	*	1	FEED ROCK SHAFT DRIVING FRAME LEVER PINCH SCREW
21	544208-005	*	*	*	*	*	*	2	FEED ROCK SHAFT DRIVING FRAME LEVER STUD SET SCREW
22	552490	*	*	*	*	*	*	1	FEED ROCK SHAFT DRIVING LINK
23	554680	*	*	*	*	*	*	1	FEED ROCK SHAFT CRANK COMP.
24	374107-004	*	*	*	*	*	*	1	FEED ROCK SHAFT CRANK PINCH SCREW
25	552493	*	*	*	*	*	*	1	FEED ROCK SHAFT CRANK PIN
26	543801-006	*	*	*	*	*	*	2	FEED ROCK SHAFT CRANK PIN SNAP RING
27	554756	*	*	*	*	*	*	1	FEED REGULATING LINK
28	554797	*	*	*	*	*	*	2	FEED REGULATING LINK STUD
31	554785	*	*	*	*	*	*	1	FEED REVERSE LINK STUD COMP.
32	412226	*	*	*	*	*	*	1	FEED REVERSE LINK STUD THRUST WASHER
33	543571	*	*	*	*	*	*	1	FEED REVERSE LINK STUD SNAP RING
34	554757	*	*	*	*	*	*	1	FEED REVERSE LINK
35	554754	*	*	*	*	*	*	1	FEED REVERSE LEVER SHAFT CRANK COMP.
36	374107-004	*	*	*	*	*	*	1	FEED REVERSE LEVER SHAFT CRANK PINCH SCREW
37	549288	*	*	*	*	*	*	1	FEED REVERSE LEVER SHAFT CRANK HINGE SCREW
38	544840	*	*	*	*	*	*	2	FEED ROCK SHAFT DRIVING FRAME BALANCE WEIGHT BRACKET SPRING WASHER



# FEED REGULATING DIAL, FEED REVERSE LEVER

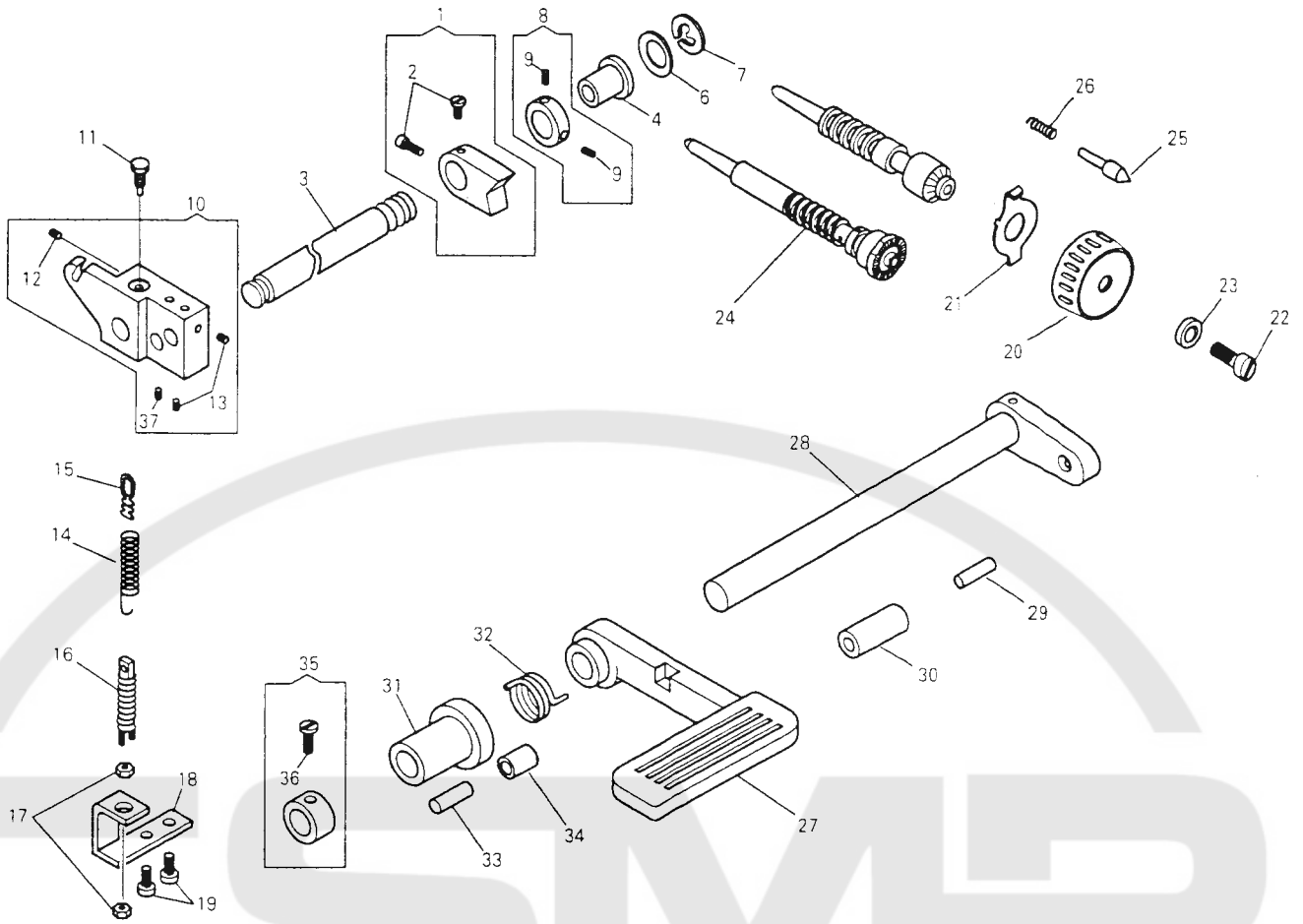

NO.	PART NO.	157A	157J	157K	557A	557J	557K	Q	DESCRIPTION
1	552494	*	*	*	*	*	*	1	FEED REGULATOR COMP.
2	374300	*	*	*	*	*	*	2	FEED REGULATOR SCREW
3	552496	*	*	*	*	*	*	1	FEED REGULATOR SHAFT
4	552497	*	*	*	*	*	*	1	FEED REGULATOR SHAFT BUSHING
6	418340	*	*	*	*	*	*	1	FEED REGULATOR SHAFT THRUST WASHER
7	543801-010	*	*	*	*	*	*	1	FEED REGULATOR SHAFT SNAP RING
8	552719	*	*	*	*	*	*	1	FEED REGULATOR SHAFT COLLAR COMP.
9	544207-011	*	*	*	*	*	*	2	FEED REGULATOR SHAFT COLLAR SET SCREW
10	554752	*	*	*	*	*	*	1	FEED REGULATOR SHAFT ARM COMP.
11	368108	*	*	*	*	*	*	1	FEED REGULATOR SHAFT ARM POSITION SCREW
12	544205-001	*	*	*	*	*	*	1	FEED REGULATOR SHAFT ARM SET SCREW
13	544208-005	*	*	*	*	*	*	2	FEED REGULATING STUD SET SCREW
14	554499	*	*	*	*	*	*	1	FEED REGULATOR SHAFT ARM SPRING
15	554500	*	*	*	*	*	*	1	FEED REGULATOR SHAFT ARM SPRING HOOK (UPPER)
16	554498	*	*	*	*	*	*	1	FEED REGULATOR SHAFT ARM SPRING HOOK (LOWER)
17	541166-001	*	*	*	*	*	*	2	FEED REGULATOR SHAFT ARM SPRING HOOK (LOWER) LOCK NUT
18	554501	*	*	*	*	*	*	1	FEED REGULATOR SHAFT ARM SPRING HOOK RETAINER
19	544213-053	*	*	*	*	*	*	2	FEED REGULATOR SHAFT ARM SPRING HOOK RETAINER SCREW
20	552514	*	*	*	*	*	*	1	FEED REGULATING DIAL
21	544947	*	*	*	*	*	*	1	FEED REGULATING DIAL SERRATION PLATE
22	368362	*	*	*	*	*	*	1	FEED REGULATING DIAL CAP SCREW
23	368363	*	*	*	*	*	*	1	FEED REGULATING DIAL CAP SCREW WASHER
24	552515	*	*	*	*	*	*	1	FEED REGULATING STUD
24	554455	*	*	*	*	*	*	1	FEED REGULATING STUD

NO.	PART NO.	157A	157J	157K	557A	557J	557K	Q	DESCRIPTION
25	368114	*	*	*	*	*	*	1	FEED REGULATING DIAL LOCK PIN
26	545820	*	*	*	*	*	*	1	FEED REGULATING DIAL LOCK PIN SPRING
27	552516	*	*	*	*	*	*	1	FEED REVERSE LEVER
28	552518	*	*	*	*	*	*	1	FEED REVERSE LEVER SHAFT ARM COMP.
29	543831-001	*	*	*	*	*	*	1	FEED REVERSE LEVER SHAFT ARM PIN
30	552521	*	*	*	*	*	*	1	FEED REVERSE LEVER SHAFT ARM PIN COVER
31	368129	*	*	*	*	*	*	1	FEED REVERSE LEVER SHAFT BUSHING
32	368130	*	*	*	*	*	*	1	FEED REVERSE LEVER SPRING
33	375653	*	*	*	*	*	*	1	FEED REVERSE LEVER STOPPER PIN
34	375662	*	*	*	*	*	*	1	FEED REVERSE LEVER STOPPER PIN COVER
35	552552	*	*	*	*	*	*	1	FEED REVERSE LEVER SHAFT COLLAR COMP.
36	374062	*	*	*	*	*	*	1	FEED REVERSE LEVER SHAFT COLLAR SET SCREW
37	544208-005	*	*	*	*	*	*	1	FEED REVERSE LINK STUD SET SCREW

# FEED BAR, FEED DRIVING ROCK SHAFT

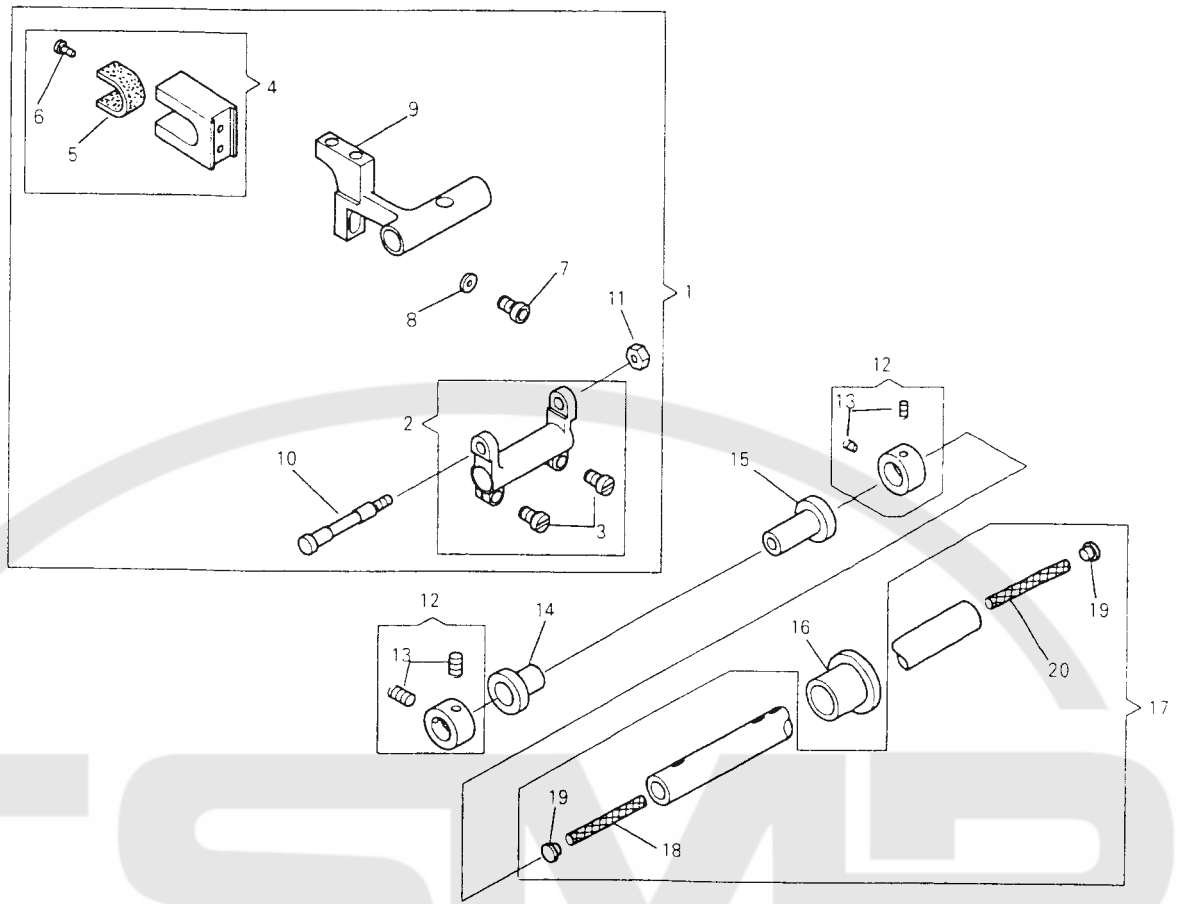

NO.	PART NO.	PART NO.					QTY	DESCRIPTION
		157A	157J	157K	557A	557J		
1	412159	*	*	*	*	*	1	FEED BAR AND FEED DRIVING ROCK FRAME COMP.
2	412022	*	*	*	*	*	1	FEED DRIVING ROCK FRAME COMP.
3	545154	*	*	*	*	*	2	FEED DRIVING ROCK FRAME PINCH SCREW
4	412161	*	*	*	*	*	1	FEED LIFTING ECCENTRIC FORK COMP.
5	223655	*	*	*	*	*	1	FEED LIFTING ECCENTRIC FORK OILING FELT
6	549075	*	*	*	*	*	1	FEED LIFTING ECCENTRIC FORK OILING FELT SCREW
7	544411	*	*	*	*	*	1	FEED LIFTING ECCENTRIC FORK SCREW
8	543804-025	*	*	*	*	*	1	FEED LIFTING ECCENTRIC FORK SCREW WASHER
9	412024	*	*	*	*	*	1	FEED BAR COMP.
10	412089	*	*	*	*	*	1	FEED BAR HINGE SCREW
11	545405	*	*	*	*	*	1	FEED BAR HINGE SCREW NUT
12	508327	*	*	*	*	*	2	FEED ROCK SHAFT STOP COLLAR COMP.
13	154780	*	*	*	*	*	4	FEED ROCK SHAFT STOP COLLAR SET SCREW
14	552523	*	*	*	*	*	1	FEED ROCK SHAFT BUSHING (FRONT)
15	367397	*	*	*	*	*	1	FEED ROCK SHAFT BUSHING (MIDDLE)
16	552524	*	*	*	*	*	1	FEED ROCK SHAFT BUSHING (BACK)
17	552525	*	*	*	*	*	1	FEED ROCK SHAFT COMP.
18	554465-004	*	*	*	*	*	1	FEED ROCK SHAFT OIL PACKING (WICK) (LONG)
19	502987	*	*	*	*	*	2	FEED ROCK SHAFT OIL HOLE PLUG
20	554465-001	*	*	*	*	*	1	FEED DRIVING ROCK SHAFT OIL PACKING (WICK) (SHORT)

NO.	PART NO.	PART NO.					QTY	DESCRIPTION
		157A	157J	157K	557A	557J		

# HOOK DRIVING SHAFT, HOOK DRIVING SHAFT CONNECTION BELT PULLEY

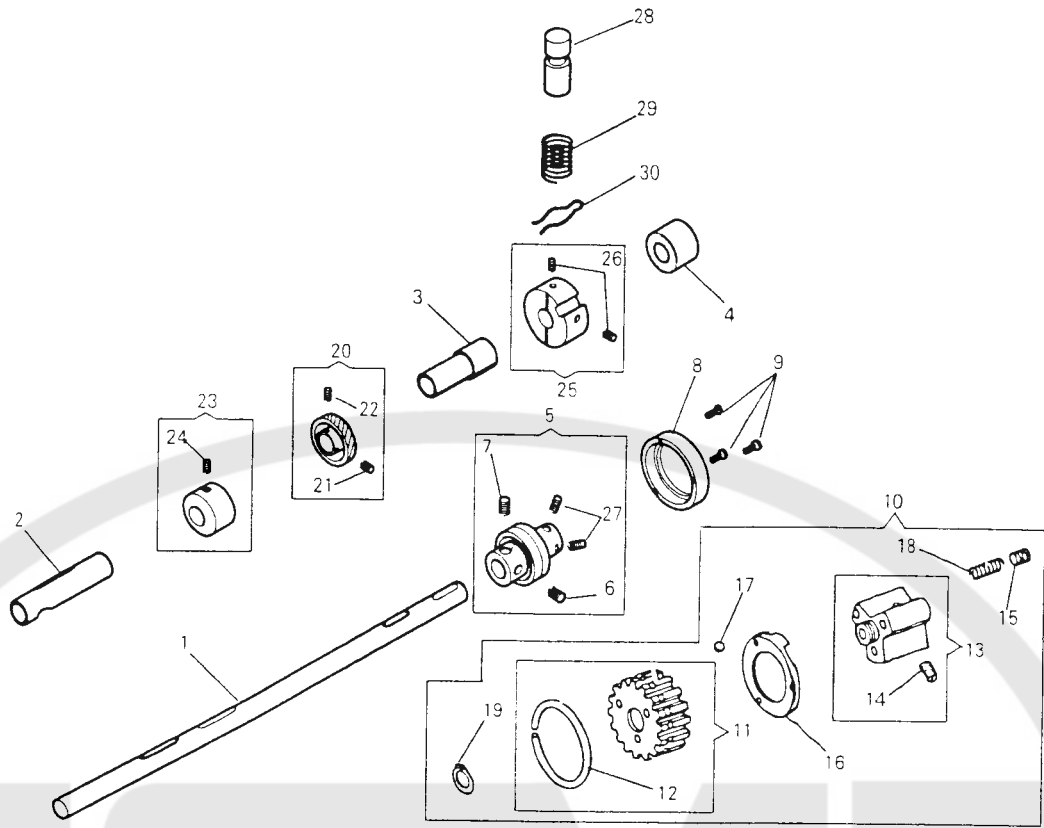

NO	PART NO.	157A	157J	157K	557A	557J	557K	Y	T	Q	DESCRIPTION
		*	*	*	*	*	*				
1	552528	*	*	*	*	*	*	1			HOOK DRIVING SHAFT
2	267195	*	*	*	*	*	*	1			HOOK SADDLE BEARING (LEFT)
3	416699	*	*	*	*	*	*	1			HOOK SADDLE BEARING (RIGHT)
4	552529	*	*	*	*	*	*	1			HOOK DRIVING SHAFT BUSHING (CENTER)
5	554676	*	*	*	*	*	*	1			HOOK DRIVING SHAFT BALL BEARING COMP
6	544329	*	*	*	*	*	*	1			HOOK DRIVING SHAFT BALL BEARING COLLAR POSITION SCREW
7	544325	*	*	*	*	*	*	1			HOOK DRIVING SHAFT BALL BEARING COLLAR SET SCREW
8	267063	*	*	*	*	*	*	1			HOOK DRIVING SHAFT BALL BEARING RETAINING WASHER
9	544346	*	*	*	*	*	*	3			HOOK DRIVING SHAFT BALL BEARING RETAINING WASHER SCREW
10	412031	*	*	*	*	*	*	1			SAFETY CLUTCH COMP.
11	244760	*	*	*	*	*	*	1			SAFETY CLUTCH BELT PULLEY
12	202253	*	*	*	*	*	*	1			SAFETY CLUTCH BELT PULLEY SPRING
13	412032	*	*	*	*	*	*	1			SAFETY CLUTCH OVERLOAD PULLEY COMP.
14	544322	*	*	*	*	*	*	2			SAFETY CLUTCH OVERLOAD PULLEY SET SCREW
15	544331	*	*	*	*	*	*	3			SAFETY CLUTCH OVERLOAD PULLEY ADJUSTING SCREW
16	514453	*	*	*	*	*	*	1			SAFETY CLUTCH DISC
17	276025	*	*	*	*	*	*	3			SAFETY CLUTCH DRIVING BALL
18	514454	*	*	*	*	*	*	3			SAFETY CLUTCH DRIVING BALL SPRING
19	543802-014	*	*	*	*	*	*	1			SAFETY CLUTCH OVERLOAD PULLEY RETAINING RING
20	412034	*	*	*	*	*	*	1			HOOK DRIVING GEAR COMP.
21	544329	*	*	*	*	*	*	1			HOOK DRIVING GEAR POSITION SCREW
22	544325	*	*	*	*	*	*	1			HOOK DRIVING GEAR SET SCREW
23	412026	*	*	*	*	*	*	1			FEED LIFTING ECCENTRIC COMP
24	544329	*	*	*	*	*	*	1			FEED LIFTING ECCENTRIC SET SCREW

NO	PART NO.	157A	157J	157K	557A	557J	557K	Y	T	Q	DESCRIPTION
		*	*	*	*	*	*				
25	554679	*	*	*	*	*	*	1			HOOK DRIVING SHAFT COLLAR COMP
26	544204-002	*	*	*	*	*	*	2			HOOK DRIVING SHAFT COLLAR SET SCREW
27	545174-452	*	*	*	*	*	*	2			HOOK DRIVING SHAFT BALL BEARING COLLAR SET SCREW
28	554678	*	*	*	*	*	*	1			FEED REGULATING STUD
29	270026	*	*	*	*	*	*	1			FEED REGULATING STUD SPRING
30	240245	*	*	*	*	*	*	1			FEED REGULATING STUD RETAINING SPRING

# HOOK SADDLE (RIGHT), HOOK

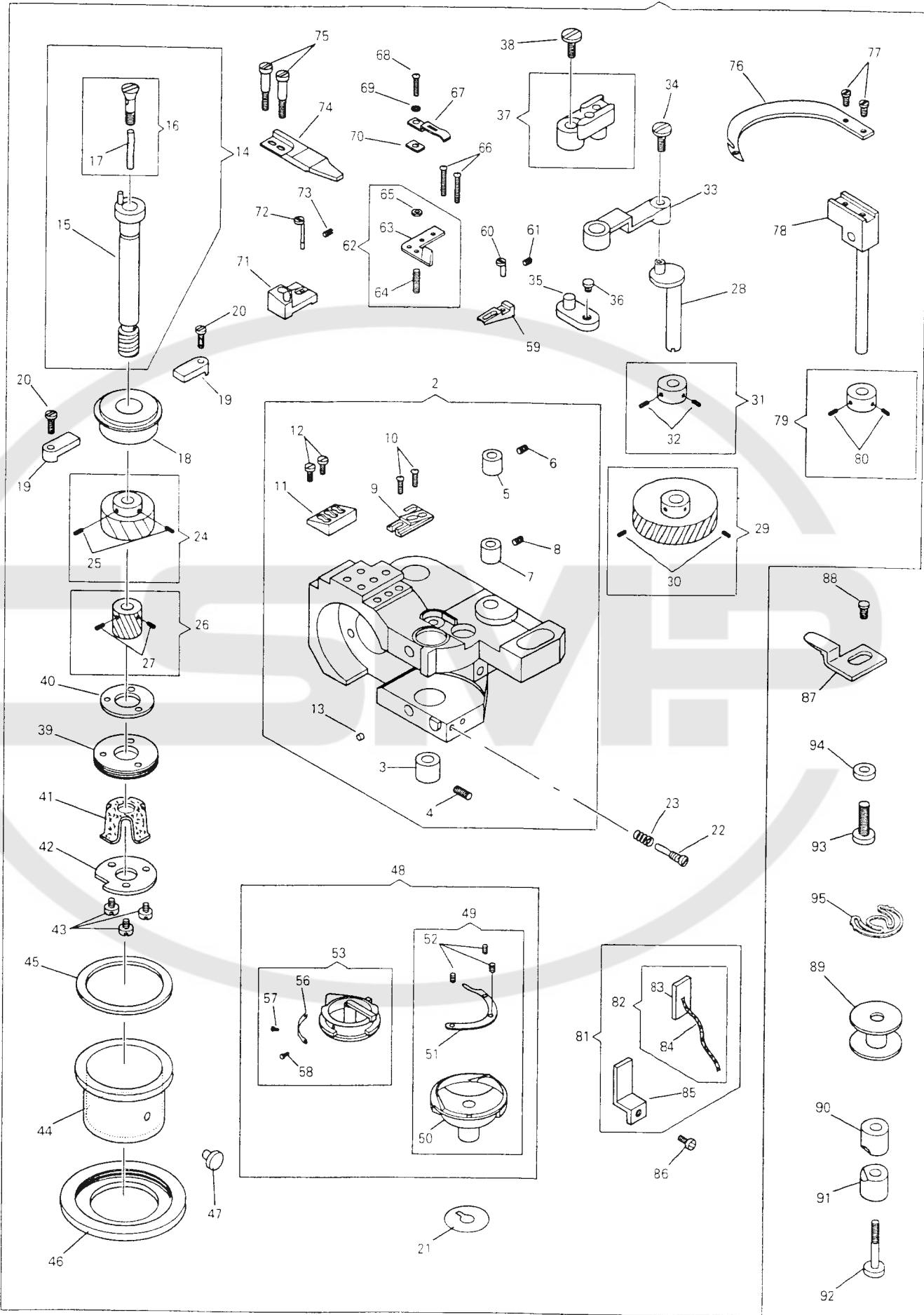

NO	PART NO.	157A	157J	157K	157A	157J	157K	Y	T	Q	DESCRIPTION
1	554460	*	*	*	*	*	*	1			HOOK SADDLE (RIGHT) WITH HOOK COMP
1	554701	*	*	*	*	*	*	1			HOOK SADDLE (RIGHT) WITH HOOK COMP
1	554706	*	*	*	*	*	*	1			HOOK SADDLE (RIGHT) WITH HOOK COMP
1	554711	*	*	*	*	*	*	1			HOOK SADDLE (RIGHT) WITH HOOK COMP
2	554461	*	*	*	*	*	*	1			HOOK SADDLE (RIGHT) COMP.
2	554702	*	*	*	*	*	*	1			HOOK SADDLE (RIGHT) COMP.
2	554707	*	*	*	*	*	*	1			HOOK SADDLE (RIGHT) COMP.
2	554712	*	*	*	*	*	*	1			HOOK SADDLE (RIGHT) COMP.
3	554643-001	*	*	*	*	*	*	1			HOOK SHAFT BUSHING (LOWER)
3	554643-002	*	*	*	*	*	*	1			HOOK SHAFT BUSHING (LOWER)
4	504020	*	*	*	*	*	*	1			HOOK SHAFT BUSHING (LOWER) SET SCREW
5	282784-001	*	*	*	*	*	*	1			BOBBIN CASE OPENER CAM SHAFT BUSHING (UPPER)
6	544207-011	*	*	*	*	*	*	1			BOBBIN CASE OPENER CAM SHAFT BUSHING (UPPER) SET SCREW
7	282784-002	*	*	*	*	*	*	1			BOBBIN CASE OPENER CAM SHAFT BUSHING (LOWER)
8	544207-011	*	*	*	*	*	*	1			BOBBIN CASE OPENER CAM SHAFT BUSHING (LOWER) SET SCREW
9	281039	*	*	*	*	*	*	1			THREAD PULLER SUPPORT
10	544211-052	*	*	*	*	*	*	2			ADJUSTING BLOCK (LOWER) THREAD PULLER SUPPORT
11	281040	*	*	*	*	*	*	1			ADJUSTING BLOCK (LOWER) SET SCREW
12	544211-052	*	*	*	*	*	*	2			STATIONARY KNIFE ADJUSTING BLOCK (LOWER)
13	554641	*	*	*	*	*	*	1			STATIONARY KNIFE ADJUSTING BLOCK (LOWER) SET SCREW
14	554646	*	*	*	*	*	*	1			HOOK SADDLE PLUG
15	554647	*	*	*	*	*	*	1			HOOK SHAFT HOOK SHAFT OIL WICK HOLDER COMP.
16	554648	*	*	*	*	*	*	1			HOOK SHAFT COMP.
17	502928	*	*	*	*	*	*	1			HOOK SHAFT OIL WICK HOLDER COMP.
18	267053	*	*	*	*	*	*	1			HOOK SHAFT OIL FELT
19	514173	*	*	*	*	*	*	1			HOOK BALL BEARING
20	504010-452	*	*	*	*	*	*	2			HOOK BALL BEARING RETAINER
21	514170	*	*	*	*	*	*	4			HOOK BALL BEARING RETAINER SCREW
22	554839	*	*	*	*	*	*	1			HOOK SPACER
23	544958	*	*	*	*	*	*	1			OIL REGULATING SCREW
24	554644	*	*	*	*	*	*	1			OIL REGULATING SCREW SPRING
25	544325	*	*	*	*	*	*	2			HOOK DRIVING PINION COMP.
26	554645	*	*	*	*	*	*	1			HOOK DRIVING PINION SET SCREW
27	544207-011	*	*	*	*	*	*	2			BOBBIN CASE OPENER CAM SHAFT ACTUATING GEAR COMP.
28	282788	*	*	*	*	*	*	1			BOBBIN CASE OPENER CAM SHAFT ACTUATING GEAR SET SCREW
29	282789	*	*	*	*	*	*	1			BOBBIN CASE OPENER CAM SHAFT BOBBIN CASE OPENER CAM SHAFT
30	544207-011	*	*	*	*	*	*	2			GEAR COMP.
31	282790	*	*	*	*	*	*	1			BOBBIN CASE OPENER CAM SHAFT GEAR SET SCREW
32	544207-011	*	*	*	*	*	*	2			BOBBIN CASE OPENER CAM SHAFT COLOR COMP.
33	282791	*	*	*	*	*	*	1			BOBBIN CASE OPENER CAM SHAFT COLOR SET SCREW
33	282802	*	*	*	*	*	*	1			BOBBIN CASE OPENER CRANK LINK
34	544356	*	*	*	*	*	*	1			BOBBIN CASE OPENER CRANK LINK BOBBIN CASE OPENER CRANK LINK
35	412283	*	*	*	*	*	*	1			CAP SCREW
36	544383	*	*	*	*	*	*	1			BOBBIN CASE OPENER CRANK HINGE STUD
37	282792	*	*	*	*	*	*	1			BOBBIN CASE OPENER CRANK HINGE STUD SCREW
38	544356	*	*	*	*	*	*	1			BOBBIN CASE OPENER CRANK COMP.
39	554659	*	*	*	*	*	*	1			BOBBIN CASE OPENER CRANK SCREW
40	554668	*	*	*	*	*	*	1			HOOK SADDLE OIL RESERVOIR BRACKET
41	281046	*	*	*	*	*	*	1			HOOK SADDLE OIL RESERVOIR BRACKET GASKET
42	554608	*	*	*	*	*	*	1			HOOK OIL FELT
43	544211-003	*	*	*	*	*	*	3			HOOK OIL FELT RETAINER
44	554658	*	*	*	*	*	*	1			HOOK OIL FELT RETAINER SCREW
45	554661	*	*	*	*	*	*	1			HOOK SADDLE OIL RESERVOIR GASKET
46	554660	*	*	*	*	*	*	1			HOOK SADDLE OIL RESERVOIR RING

NO	PART NO.	157A	157J	157K	157A	157J	157K	Y	T	Q	DESCRIPTION
47	367314	*	*	*	*	*	*	1			HOOK SADDLE OIL RESERVOIR PLUG
48	554824	*	*	*	*	*	*	1			HOOK AND BOBBIN CASE COMP.
48	554825	*	*	*	*	*	*	1			HOOK AND BOBBIN CASE COMP.
49	554606	*	*	*	*	*	*	1			HOOK COMP
49	554611	*	*	*	*	*	*	1			HOOK COMP.
50	554607	*	*	*	*	*	*	1			HOOK (BODY)
50	554612	*	*	*	*	*	*	1			HOOK (BODY)
51	281135	*	*	*	*	*	*	1			HOOK GIB
51	412311	*	*	*	*	*	*	1			HOOK GIB
52	201253	*	*	*	*	*	*	2			HOOK GIB SCREW
52	500520	*	*	*	*	*	*	3			HOOK GIB SCREW
53	281136	*	*	*	*	*	*	1			BOBBIN CASE COMP
53	281146	*	*	*	*	*	*	1			BOBBIN CASE COMP.
56	236083	*	*	*	*	*	*	1			BOBBIN CASE TENSION SPRING
56	510011	*	*	*	*	*	*	1			BOBBIN CASE TENSION SPRING
57	201016	*	*	*	*	*	*	1			BOBBIN CASE TENSION SPRING REGULATING SCREW
57	500519	*	*	*	*	*	*	1			BOBBIN CASE TENSION SPRING REGULATING SCREW
58	200594	*	*	*	*	*	*	1			BOBBIN CASE TENSION SPRING SCREW
58	500518	*	*	*	*	*	*	1			BOBBIN CASE TENSION SPRING SCREW
59	281056	*	*	*	*	*	*	1			THREAD PULLER SUPPORT
60	543376	*	*	*	*	*	*	1			ADJUSTING BLOCK (UPPER)
61	544207-011	*	*	*	*	*	*	1			ADJUSTING BLOCK (UPPER) ECCENTRIC PIN
62	281054	*	*	*	*	*	*	1			ADJUSTING BLOCK (UPPER) ECCENTRIC PIN SET SCREW
63	281055	*	*	*	*	*	*	1			ADJUSTING BLOCK (UPPER) ECCENTRIC PIN SET SCREW
64	374475	*	*	*	*	*	*	1			THREAD PULLER SUPPORT
65	541159	*	*	*	*	*	*	1			TRAPPER ADJUSTING SCREW
66	374478	*	*	*	*	*	*	2			TRAPPER ADJUSTING SCREW NUT
67	281057	*	*	*	*	*	*	1			THREAD PULLER SUPPORT SCREW
68	544413	*	*	*	*	*	*	1			TRAPPER
69	408386	*	*	*	*	*	*	1			TRAPPER SET SCREW
70	548228	*	*	*	*	*	*	1			TRAPPER SET SCREW WASHER
71	281059	*	*	*	*	*	*	1			TRAPPER ADJUSTING WASHER
72	281060	*	*	*	*	*	*	1			STATIONARY KNIFE ADJUSTING BLOCK (UPPER) ECCENTRIC PIN
73	544207-011	*	*	*	*	*	*	1			STATIONARY KNIFE ADJUSTING BLOCK (UPPER) ECCENTRIC PIN SET SCREW
74	281058	*	*	*	*	*	*	1			STATIONARY KNIFE
75	374476	*	*	*	*	*	*	2			STATIONARY KNIFE SET SCREW
76	281050-001	*	*	*	*	*	*	2			THREAD PULLER
77	544088	*	*	*	*	*	*	2			THREAD PULLER SCREW
78	281051	*	*	*	*	*	*	1			THREAD PULLER RETAINER BRACKET COMP.
78	282803	*	*	*	*	*	*	1			THREAD PULLER RETAINER BRACKET COMP.
79	281064	*	*	*	*	*	*	1			THREAD PULLER RETAINER BRACKET SHAFT COLLAR COMP.
80	544207-011	*	*	*	*	*	*	2			THREAD PULLER RETAINER BRACKET SHAFT COLLAR SET SCREW
81	552891	*	*	*	*	*	*	1			HOOK DRIVING PINION OIL FELT, OIL FELT BRACKET COMP.
82	552892	*	*	*	*	*	*	1			HOOK DRIVING PINION OIL FELT, OIL PACKING (WICK) COMP.
83	552894	*	*	*	*	*	*	1			HOOK DRIVING PINION OIL FELT
84	552895	*	*	*	*	*	*	1			HOOK DRIVING PINION OIL PACKING (WICK)
85	552893	*	*	*	*	*	*	1			HOOK DRIVING PINION OIL FELT BRACKET
86	544211-002	*	*	*	*	*	*	1			HOOK DRIVING PINION OIL FELT BRACKET SCREW
87	282793	*	*	*	*	*	*	1			BOBBIN CASE OPENER
88	549027	*	*	*	*	*	*	1			BOBBIN CASE OPENER SCREW
89	282762	*	*	*	*	*	*	1			BOBBIN
89	282763	*	*	*	*	*	*	1			BOBBIN
89	282764	*	*	*	*	*	*	1			BOBBIN
90	412115	*	*	*	*	*	*	1			PINCH SLEEVE (UPPER)
91	267139	*	*	*	*	*	*	1			PINCH SLEEVE (LOWER)
92	544364	*	*	*	*	*	*	1			PINCH SLEEVE SCREW
93	544334	*	*	*	*	*	*	1			HOOK SADDLE (RIGHT) SCREW
94	225585	*	*	*	*	*	*	1			HOOK SADDLE (RIGHT) SCREW WASHER
95	417195	*	*	*	*	*	*	1			ANTI SPILL SPRING
95	417269	*	*	*	*	*	*	1			ANTI SPILL SPRING

# LUBRICATION (PLUNGER PUMP)

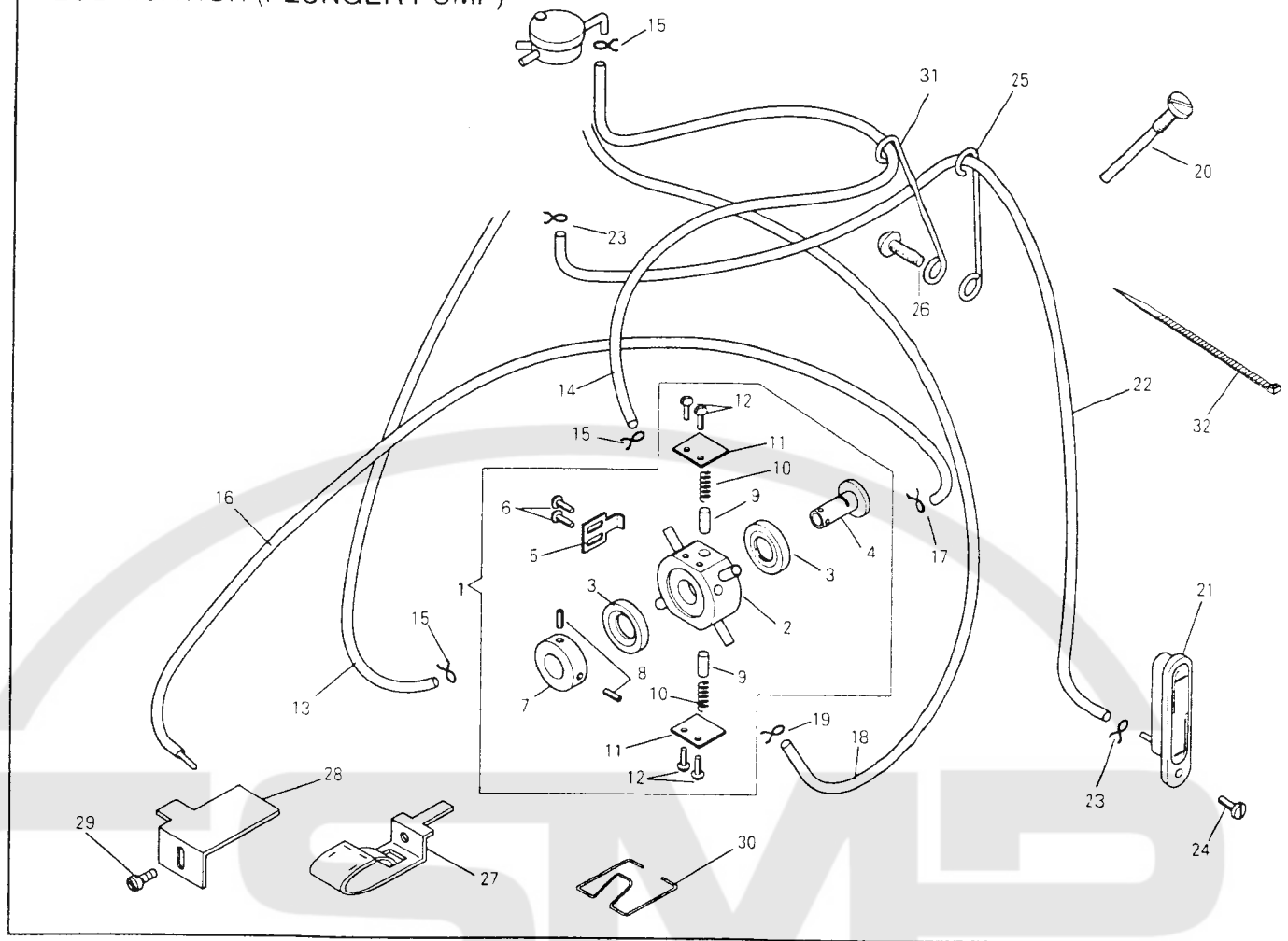

NO	PART NO.	T-Q				DESCRIPTION
		157A	157J	157K	557A	
1	554346	*	*	*	*	1 PLUNGER PUMP COMP.
2	554347	*	*	*	*	1 PLUNGER PUMP (BODY) COMP.
3	554349	*	*	*	*	2 OIL SEAL
4	554351	*	*	*	*	1 PLUNGER PUMP ROTOR
5	554353	*	*	*	*	1 PLUNGER PUMP ROTOR RETAINER
6	544211-002	*	*	*	*	2 PLUNGER PUMP ROTOR RETAINER SCREW
7	554352	*	*	*	*	1 PLUNGER PUMP ROTOR COLLAR
8	549293	*	*	*	*	2 PLUNGER PUMP ROTOR COLLAR SET SCREW
9	540556	*	*	*	*	2 PLUNGER PUMP PISTON
10	410710	*	*	*	*	2 PLUNGER PUMP PISTON SPRING
11	554354	*	*	*	*	2 PLUNGER PUMP PISTON SPRING RETAINER
12	544211-002	*	*	*	*	4 PLUNGER PUMP PISTON SPRING RETAINER SCREW
13	552826	*	*	*	*	1 OIL TUBE (SUCTION)
14	552827	*	*	*	*	1 OIL TUBE (DISCHARGE)
15	552809	*	*	*	*	3 OIL TUBE CLIP
16	552833	*	*	*	*	1 OIL REMOVING TUBE (SUCTION) COMP
17	552810	*	*	*	*	1 OIL REMOVING TUBE CLIP
18	554464	*	*	*	*	1 OIL REMOVING TUBE (DISCHARGE) CLIP
19	552810	*	*	*	*	1 OIL REMOVING TUBE (DISCHARGE) CLIP
20	374543	*	*	*	*	1 PLUNGER PUMP SUPPORT SCREW
21	552546-401	*	*	*	*	1 OIL GAUGE COMP.
22	552828	*	*	*	*	1 OIL TUBE (FOR OIL GAUGE)
23	552809	*	*	*	*	2 OIL TUBE (FOR OIL GAUGE) CLIP
24	545071	*	*	*	*	1 OIL GAUGE SCREW
25	554537	*	*	*	*	1 OIL TUBE RETAINER (FOR OIL GAUGE)
26	544217-052	*	*	*	*	1 OIL TUBE RETAINER SCREW
27	554306	*	*	*	*	1 OIL REMOVING LINT SCREEN
28	554433	*	*	*	*	1 OIL REMOVING LINT SCREEN BRACKET
29	544269	*	*	*	*	1 OIL REMOVING LINT SCREEN BRACKET SCREW

NO	PART NO.	T-Q				DESCRIPTION
		157A	157J	157K	557A	
30	554860	*	*	*	*	1 OIL REMOVING LINT SCREEN RETAINER
31	552829	*	*	*	*	1 OIL TUBE RETAINER (FOR DISCHARGE)
32	411584	*	*	*	*	1 OIL TUBE RETAINER

# LUBRICATION (OIL RESERVOIR)

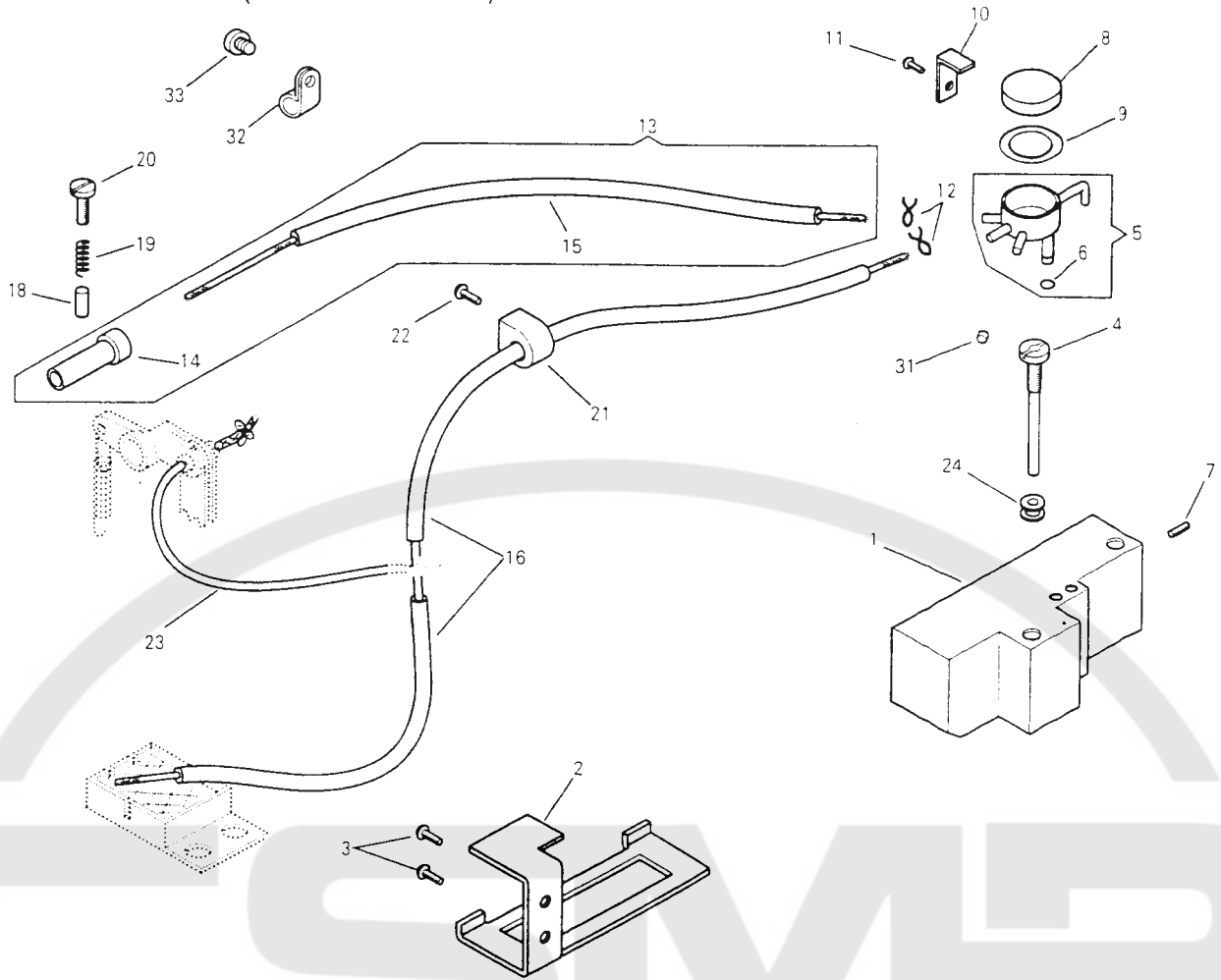

NO.	PART NO.						QTY	DESCRIPTION
		157A	157J	157K	557A	557J		
1	552548	*	*	*	*	*	1	OIL RESERVOIR
2	552550	*	*	*	*	*	1	OIL RESERVOIR BRACKET
3	374399-002	*	*	*	*	*	2	OIL RESERVOIR BRACKET SCREW
4	374560	*	*	*	*	*	1	OIL SUPPLY SLEEVE SCREW
5	554362	*	*	*	*	*	1	OIL DISTRIBUTOR AND O-RING COMP.
6	543871-006	*	*	*	*	*	1	OIL DISTRIBUTOR O-RING
7	544202-002	*	*	*	*	*	1	OIL DISTRIBUTOR SCREW
8	552507	*	*	*	*	*	1	OIL DISTRIBUTOR CAP
9	554439	*	*	*	*	*	1	OIL DISTRIBUTOR CAP O-RING
10	552476	*	*	*	*	*	1	OIL DISTRIBUTOR CAP RETAINER
11	544216-001	*	*	*	*	*	1	OIL DISTRIBUTOR CAP RETAINER SCREW
12	552809	*	*	*	*	*	2	OIL DISTRIBUTOR TUBE CLIP
13	554314	*	*	*	*	*	1	TAKE-UP LEVER OIL TUBE, OIL FLOW ADJUSTING RUBBER SLEEVE COMP.
14	554313	*	*	*	*	*	1	TAKE-UP LEVER OIL FLOW ADJUSTING RUBBER SLEEVE
15	552830	*	*	*	*	*	1	TAKE-UP LEVER OIL TUBE AND WICK COMP.
16	552831	*	*	*	*	*	1	OIL TUBE (FOR BED) COMP.
18	554311	*	*	*	*	*	1	TAKE-UP LEVER OIL FLOW ADJUSTING PIN
19	554863	*	*	*	*	*	1	TAKE-UP LEVER OIL FLOW ADJUSTING SCREW SPRING
20	544290	*	*	*	*	*	1	TAKE-UP LEVER OIL FLOW ADJUSTING SCREW
21	554528	*	*	*	*	*	1	OIL FLOW ADJUSTING COLLAR
22	545136-452	*	*	*	*	*	1	OIL FLOW ADJUSTING COLLAR SCREW
23	554523	*	*	*	*	*	1	FEED REGULATOR SHAFT ARM STUD OIL WICK
24	543883	*	*	*	*	*	1	OIL RESERVOIR GROMMETS
31	554683	*	*	*	*	*	1	OIL DISTRIBUTOR PIPE PLUG
32	542766-002	*	*	*	*	*	1	TAKE-UP LEVER OIL TUBE RETAINER
33	544212-001	*	*	*	*	*	1	TAKE-UP LEVER OIL TUBE RETAINER SCREW

NO.	PART NO.						QTY	DESCRIPTION
		157A	157J	157K	557A	557J		

# LUBRICATION (BED AREA)

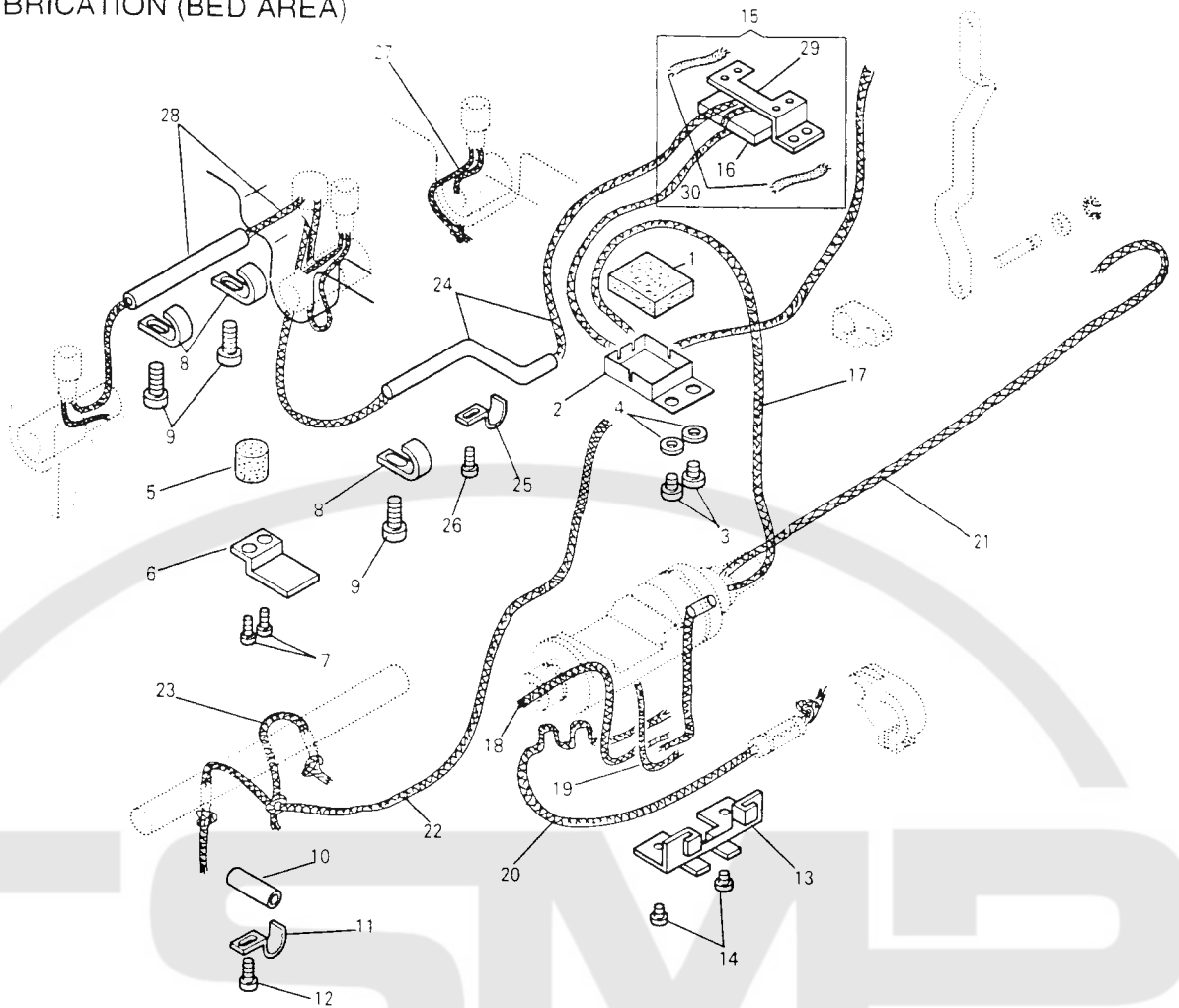

NO.	PART NO.	157A	157J	157K	557A	557J	557K	QTY	DESCRIPTION
		*	*	*	*	*	*		
1	552551	*	*	*	*	*	*	1	BED OIL FELT
2	552552	*	*	*	*	*	*	1	BED OIL FELT BARCKET
3	544212-052	*	*	*	*	*	*	2	BED OIL FELT BRACKET SCREW
4	543803-003	*	*	*	*	*	*	2	BED OIL FELT BRACKET SCREW WASHER
5	552553	*	*	*	*	*	*	1	HOOK DRIVING SHAFT OIL FELT
6	552554	*	*	*	*	*	*	1	HOOK DRIVING SHAFT OIL FELT BRACKET
7	544212-051	*	*	*	*	*	*	2	HOOK DRIVING SHAFT OIL FELT BRACKET SCREW
8	552555	*	*	*	*	*	*	3	HOOK DRIVING SHAFT OIL WICK TUBE RETAINER
9	544212-051	*	*	*	*	*	*	3	HOOK DRIVING SHAFT OIL WICK TUBE RETAINER SCREW
10	552556	*	*	*	*	*	*	1	FEED ROCK SHAFT OIL WICK TUBE
11	418604	*	*	*	*	*	*	1	FEED ROCK SHAFT OIL WICK TUBE RETAINER
12	544212-051	*	*	*	*	*	*	1	FEED ROCK SHAFT OIL WICK TUBE RETAINER SCREW
13	552557	*	*	*	*	*	*	1	FEED ROCK SHAFT DRIVING FRAME OIL WICK BRACKET
14	544212-001	*	*	*	*	*	*	2	FEED ROCK SHAFT DRIVING FRAME OIL WICK BRACKET SCREW
15	554440	*	*	*	*	*	*	1	FEED DRIVING ECCENTRIC CONNECTION FELT COMP.
16	554441	*	*	*	*	*	*	1	FEED DRIVING ECCENTRIC CONNECTION FELT
17	554465-006	*	*	*	*	*	*	1	FEED ROCK SHAFT DRIVING FRAME OIL WICK (LONG)
18	554465-011	*	*	*	*	*	*	1	FEED ROCK SHAFT DRIVING FRAME OIL WICK (SHORT)
19	554524	*	*	*	*	*	*	1	FEED ROCK SHAFT DRIVING LINK OIL WICK
20	554465-007	*	*	*	*	*	*	1	FEED ROCK SHAFT CRANK PIN OIL WICK
21	554465-005	*	*	*	*	*	*	1	NEEDLE BAR ROCK FRAME ROCK SHAFT CRANK OIL WICK

NO.	PART NO.	157A	157J	157K	557A	557J	557K	QTY	DESCRIPTION
		*	*	*	*	*	*		
22	554465-013	*	*	*	*	*	*	1	FEED ROCK SHAFT OIL WICK
23	554465-012	*	*	*	*	*	*	1	FEED ROCK SHAFT OIL WICK (RIGHT)
24	554467	*	*	*	*	*	*	1	HOOK DRIVING SHAFT OIL TUBE AND WICK
25	418604	*	*	*	*	*	*	1	HOOK DRIVING SHAFT OIL TUBE RETAINER (SMALL)
26	544212-051	*	*	*	*	*	*	1	HOOK DRIVING SHAFT OIL TUBE RETAINER (SMALL) SCREW
27	554465-010	*	*	*	*	*	*	1	HOOK DRIVING SHAFT BUSHING (CENTER) OIL WICK
28	554468	*	*	*	*	*	*	1	HOOK DRIVING SHAFT BUSHING (FRONT) OIL TUBE COMP
29	554442	*	*	*	*	*	*	1	FEED DRIVING ECCENTRIC CONNECTION FELT BRACKET
30	554781	*	*	*	*	*	*	2	FEED DRIVING ECCENTRIC CONNECTION FELT CORD.



# TENSION

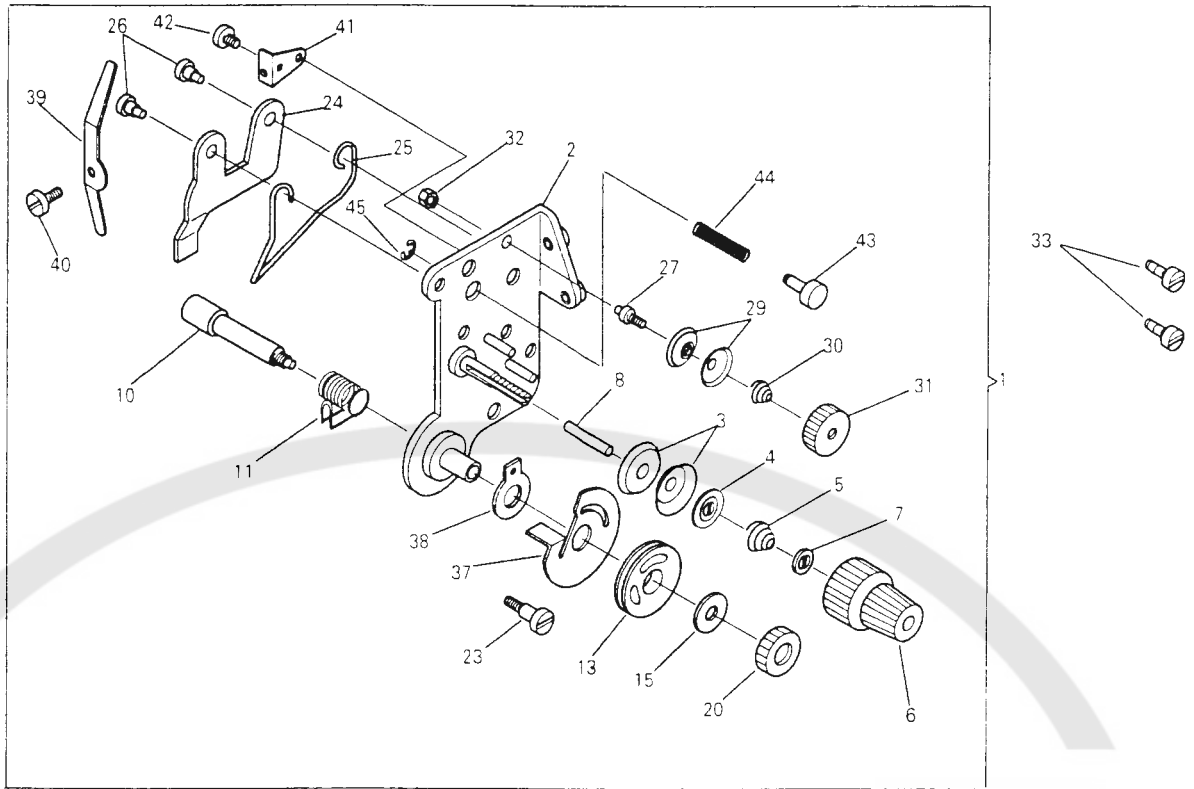

NO.	PART NO.	157A	157J	157K	557A	557J	557K	Y	T	Q	DESCRIPTION	NO.	PART NO.	157A	157J	157K	557A	557J	557K	Y	T	Q	DESCRIPTION
		*	*	*	*	*	*							*	*	*	*	*	*				
1	554903	*	*	*	*	*	*	*	*	1	TENSION BRACKET COMP.												
1	552781	*	*	*	*	*	*	*	*	1	TENSION BRACKET COMP.												
2	552782	*	*	*	*	*	*	*	*	1	TENSION BRACKET BODY COMP.												
3	2102	*	*	*	*	*	*	*	*	2	TENSION DISC												
4	414273	*	*	*	*	*	*	*	*	1	TENSION RELEASE WASHER												
5	552836	*	*	*	*	*	*	*	*	1	TENSION SPRING												
6	552838	*	*	*	*	*	*	*	*	1	TENSION REGULATING THUMB NUT												
7	411154	*	*	*	*	*	*	*	*	1	TENSION REGULATING THUMB NUT WASHER												
8	552563-001	*	*	*	*	*	*	*	*	1	TENSION RELEASE PLUNGER												
10	554823	*	*	*	*	*	*	*	*	1	THREAD CONTROLLER STUD												
11	554877	*	*	*	*	*	*	*	*	1	THREAD CONTROLLER SPRING												
13	412202	*	*	*	*	*	*	*	*	1	THREAD CONTROLLER DISC												
15	554821	*	*	*	*	*	*	*	*	1	THREAD CONTROLLER STUD SPACER												
20	552841	*	*	*	*	*	*	*	*	1	THREAD CONTROLLER STUD NUT												
23	544354	*	*	*	*	*	*	*	*	1	THREAD CONTROLLER DISC SCREW												
24	417124	*	*	*	*	*	*	*	*	1	TENSION RELEASE PLATE												
25	412200	*	*	*	*	*	*	*	*	1	TENSION RELEASE PLATE SPRING												
26	544343	*	*	*	*	*	*	*	*	2	TENSION RELEASE PLATE SCREW												
27	552567	*	*	*	*	*	*	*	*	1	PRE-TENSION STUD												
29	417122	*	*	*	*	*	*	*	*	2	PRE-TENSION DISC												
30	417123	*	*	*	*	*	*	*	*	1	PRE-TENSION SPRING												
31	414784	*	*	*	*	*	*	*	*	1	PRE-TENSION THUMB NUT												
32	414783	*	*	*	*	*	*	*	*	1	PRE-TENSION STUD LOCK NUT												
33	549168	*	*	*	*	*	*	*	*	1	TENSION BRACKET SCREW												
37	412201	*	*	*	*	*	*	*	*	1	THREAD CONTROLLER SPRING STOP												
38	554820	*	*	*	*	*	*	*	*	1	THREAD CONTROLLER SPRING STOP SPACER												
39	417126	*	*	*	*	*	*	*	*	1	TENSION RELEASE LEVER												
40	414786	*	*	*	*	*	*	*	*	1	TENSION RELEASE LEVER SCREW												
41	417125	*	*	*	*	*	*	*	*	1	TENSION RELEASE LEVER BRACKET												
42	414785	*	*	*	*	*	*	*	*	1	TENSION RELEASE LEVER BRACKET SCREW												
43	417127	*	*	*	*	*	*	*	*	1	TENSION RELEASE BUTTON												
44	417128	*	*	*	*	*	*	*	*	1	TENSION RELEASE BUTTON SPRING												
45	543801-00E	*	*	*	*	*	*	*	*	1	TENSION RELEASE BUTTON RETAINING RING												

# BOBBIN WINDER

35

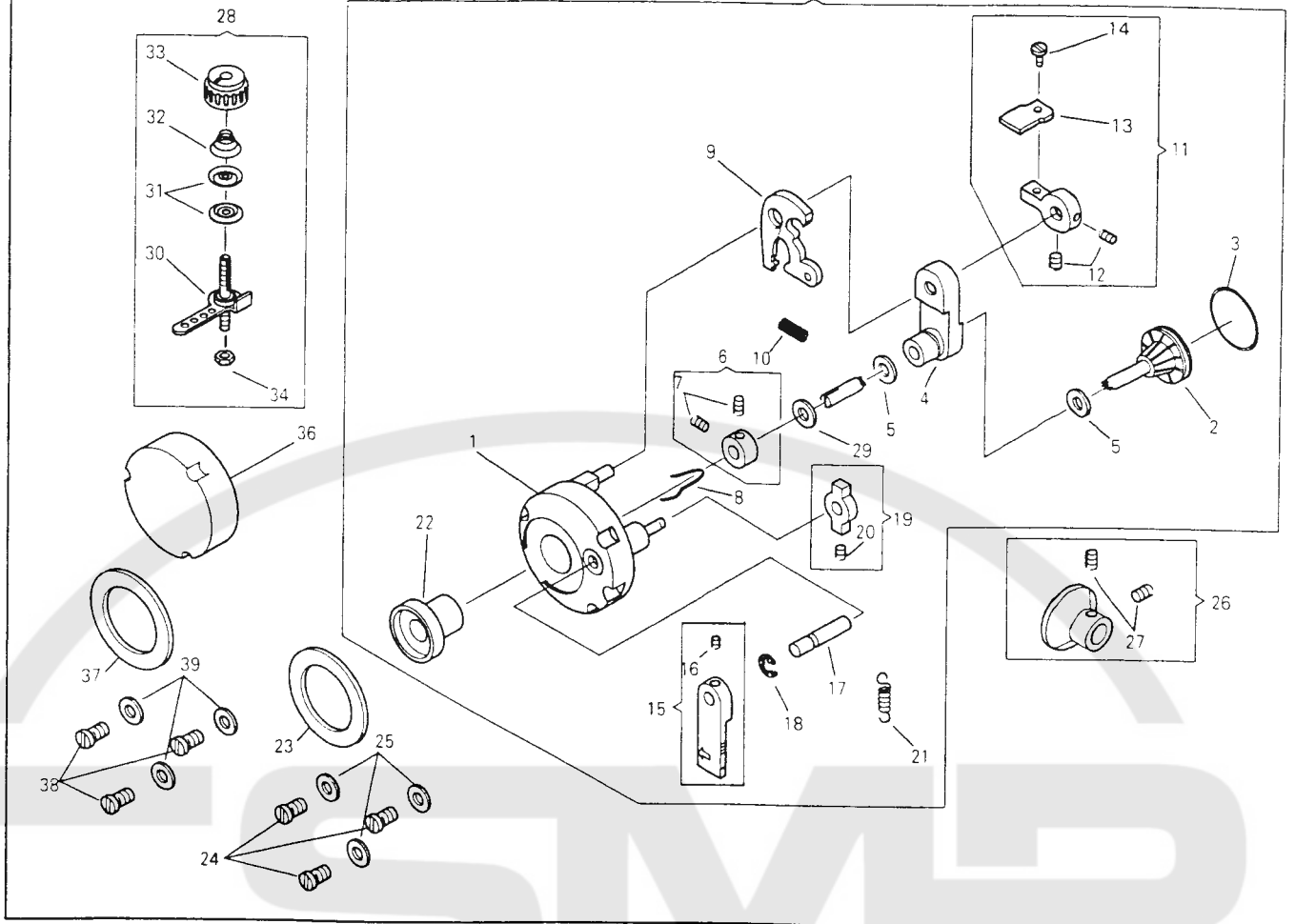

NO	PART NO.	157A	157J	157K	557A	557J	557K	Y	T	D	DESCRIPTION
1	552570	*	*	*	*	*	*	*			1 BOBBIN WINDER (BODY)
2	552573	*	*	*	*	*	*	*			1 BOBBIN WINDER PULLEY
3	543871-020	*	*	*	*	*	*	*			1 BOBBIN WINDER PULLEY RING
4	552575	*	*	*	*	*	*	*			1 BOBBIN WINDER BRACKET
5	546844	*	*	*	*	*	*	*			2 BOBBIN WINDER SPINDLE THRUST WASHER
6	282758	*	*	*	*	*	*	*			1 BOBBIN WINDER SPINDLE STOP COLLAR COMPLETE
7	544206-011	*	*	*	*	*	*	*			2 BOBBIN WINDER SPINDLE STOP COLLAR SET SCREW
8	282995	*	*	*	*	*	*	*			1 BOBBIN WINDER SPINDLE SPRING
9	282757	*	*	*	*	*	*	*			1 BOBBIN WINDER BRACKET ACTUATING PLATE
10	282994	*	*	*	*	*	*	*			1 BOBBIN WINDER BRACKET SPRING
11	552576	*	*	*	*	*	*	*			1 BOBBIN WINDER STOPPER BRACKET COMP.
12	544207-013	*	*	*	*	*	*	*			2 BOBBIN WINDER STOPPER BRACKET SCREW
13	552577	*	*	*	*	*	*	*			1 BOBBIN WINDER STOPPER
14	374398-002	*	*	*	*	*	*	*			1 BOBBIN WINDER STOPPER SCREW
15	552578	*	*	*	*	*	*	*			1 BOBBIN WINDER STOP LATCH COMPLETE
16	544208-005	*	*	*	*	*	*	*			1 BOBBIN WINDER STOP LATCH SET SCREW
17	368025	*	*	*	*	*	*	*			1 BOBBIN WINDER STOP LATCH STUD
18	543860-005	*	*	*	*	*	*	*			1 BOBBIN WINDER STOP LATCH STUD SNAP RING
19	368026	*	*	*	*	*	*	*			1 BOBBIN WINDER REGULATOR COMPLETE
20	544208-005	*	*	*	*	*	*	*			1 BOBBIN WINDER REGULATOR SET SCREW
21	544865	*	*	*	*	*	*	*			1 BOBBIN WINDER SPRING
22	282759-451	*	*	*	*	*	*	*			1 BOBBIN WINDER SPINDLE THREAD GUARD
23	554312	*	*	*	*	*	*	*			1 BOBBIN WINDER PACKING
24	544217-001	*	*	*	*	*	*	*			3 BOBBIN WINDER SCREW
25	543803-003	*	*	*	*	*	*	*			3 BOBBIN WINDER SCREW WASHER

NO	PART NO.	157A	157J	157K	557A	557J	557K	Y	T	D	DESCRIPTION
26	554409	*	*	*	*	*	*	*			1 BOBBIN WINDER DRIVING WHEEL COMPLETE
27	544207-012	*	*	*	*	*	*	*			2 BOBBIN WINDER DRIVING WHEEL SET SCREW
28	552579	*	*	*	*	*	*	*			1 BOBBIN WINDER TENSION COMPLETE
29	543804-005	*	*	*	*	*	*	*			1 BOBBIN WINDER BRACKET THRUST WASHER
30	552580	*	*	*	*	*	*	*			1 BOBBIN WINDER TENSION STUD COMP.
31	547247	*	*	*	*	*	*	*			2 BOBBIN WINDER TENSION DISC
32	547246	*	*	*	*	*	*	*			1 BOBBIN WINDER TENSION SPRING
33	368033	*	*	*	*	*	*	*			1 BOBBIN WINDER TENSION REGULATING THUMB NUT
34	541186	*	*	*	*	*	*	*			1 BOBBIN WINDER TENSION STUD LOCK NUT
35	554669-385	*	*	*	*	*	*	*			1 BOBBIN WINDER COMP.
35	552569	*	*	*	*	*	*	*			1 BOBBIN WINDER COMP.
36	554849	*	*	*	*	*	*	*			1 ARM CAP (FRONT)
37	554312	*	*	*	*	*	*	*			1 ARM CAP (FRONT) PACKING
38	544217-001	*	*	*	*	*	*	*			3 ARM CAP (FRONT) SCREW
39	543803-003	*	*	*	*	*	*	*			3 ARM CAP (FRONT) SCREW WASHER

# THREAD TRIMMER 1

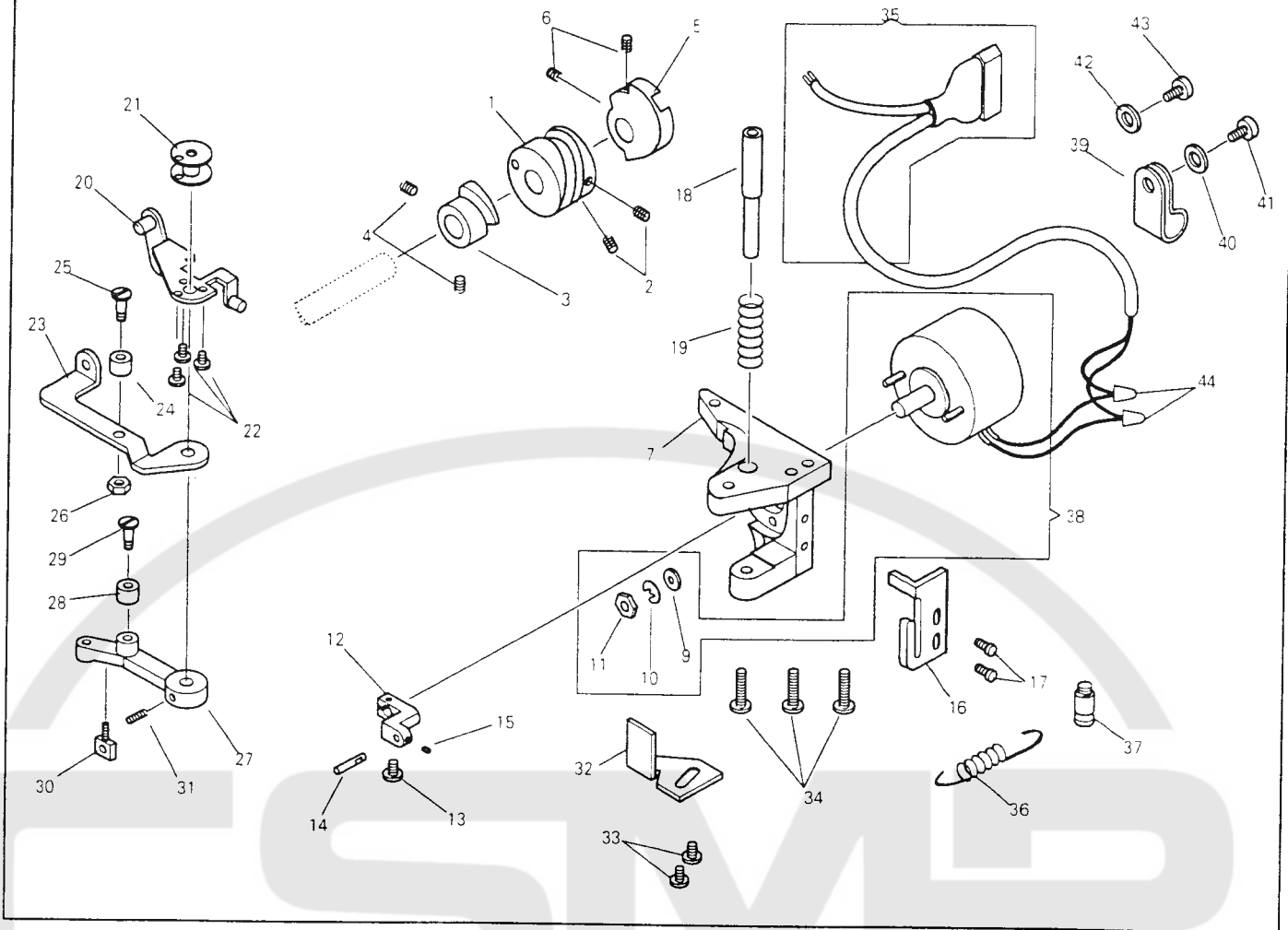

NO.	PART NO.	QTY					DESCRIPTION	NO.	PART NO.	QTY					DESCRIPTION			
		157A	157J	157K	557A	557J				557K	157A	157J	157K	557A		557J	557K	
1	281184	-	*	*	*	*	1	TRIMMER CAM	32	552591	-	*	*	*	*	1	TRIMMER LEVER STOPPER	
2	374029	-	*	*	*	*	2	TRIMMER CAM SET SCREW	33	414508	-	*	*	*	*	2	TRIMMER LEVER STOPPER SCREW	
3	281013	-	*	*	*	*	1	TENSION RELEASING CAM	34	544352	-	*	*	*	*	3	TRIMMER SOLENOID BRACKET SCREW	
4	504028	-	*	*	*	*	2	TENSION RELEASING CAM SET SCREW	35	554469	-	*	*	*	*	1	TRIMMER, BACK TACK SOLENOID CORD COMP.	
5	281014	-	*	*	*	*	1	TRIMMER POSITIVE MOTION CAM	35	554723	-	*	*	*	*	1	TRIMMER SOLENOID CORD COMP	
6	544208-005	-	*	*	*	*	2	TRIMMER POSITIVE MOTION CAM SET SCREW	36	552592	-	*	*	*	*	1	TRIMMER LEVER RETURN SPRING	
7	552585	-	*	*	*	*	1	TRIMMER SOLENOID BRACKET	37	374307	-	*	*	*	*	1	TRIMMER LEVER RETURN SPRING STUD	
9	543804-003	-	*	*	*	*	2	TRIMMER SOLENOID WASHER	38	369333	-	*	*	*	*	1	TRIMMER SOLENOID COMP.	
10	543805-003	-	*	*	*	*	2	TRIMMER SOLENOID SPRING WASHER	39	542766-002	-	*	*	*	*	2	TRIMMER SOLENOID CORD RETAINER	
11	541165-003	-	*	*	*	*	2	TRIMMER SOLENOID NUT	39	542766-002	-	*	*	*	*	4	TRIMMER SOLENOID CORD RETAINER	
12	552586	-	*	*	*	*	1	TRIMMER SOLENOID ARM	40	543803-002	-	*	*	*	*	1	TRIMMER SOLENOID CORD WASHER	
13	545095	-	*	*	*	*	1	TRIMMER SOLENOID ARM SCREW	40	543803-002	-	*	*	*	*	3	TRIMMER SOLENOID CORD WASHER	
14	416772	-	*	*	*	*	1	TRIMMER SOLENOID ARM PIN	40	543803-002	-	*	*	*	*	3	TRIMMER SOLENOID CORD WASHER	
15	545072	-	*	*	*	*	1	TRIMMER SOLENOID ARM PIN SCREW	41	504010-452	-	*	*	*	*	1	TRIMMER SOLENOID CORD SCREW	
16	281020	-	*	*	*	*	1	TRIMMER SOLENOID ARM STOPPER	41	504010-452	-	*	*	*	*	3	TRIMMER SOLENOID CORD SCREW	
17	190-850	-	*	*	*	*	2	TRIMMER SOLENOID ARM STOPPER SCREW	42	543803-003	-	*	*	*	*	1	TRIMMER SOLENOID CORD WASHER	
18	281021	-	*	*	*	*	1	TRIMMER LEVER SHAFT	43	544217-052	-	*	*	*	*	1	TRIMMER SOLENOID CORD SCREW	
19	281096	-	*	*	*	*	1	TRIMMER LEVER SHAFT SPRING	44	417142-001	-	*	*	*	*	2	TRIMMER SOLENOID WIRE CONNECTOR	
20	281023	-	*	*	*	*	1	TRIMMER POSITIVE MOTION BRACKET COMPLETE										
21	416777	-	*	*	*	*	1	TRIMMER POSITIVE MOTION BRACKET BOSS										
22	549120	-	*	*	*	*	3	TRIMMER POSITIVE MOTION BRACKET BOSS SCREW										
23	552588	-	*	*	*	*	1	TENSION RELEASE DRIVING LEVER										
24	416780	-	*	*	*	*	1	TENSION RELEASING CAM ROLLER										
25	414773-451	-	*	*	*	*	1	TENSION RELEASING CAM ROLLER SCREW										
26	545409	-	*	*	*	*	1	TENSION RELEASING CAM ROLLER SCREW LOCK NUT										
27	552590	-	*	*	*	*	1	TRIMMER LEVER										
28	416780	-	*	*	*	*	1	TRIMMER CAM ROLLER										
29	414773-451	-	*	*	*	*	1	TRIMMER CAM ROLLER SCREW										
30	545264	-	*	*	*	*	1	TRIMMER LEVER RETURN SPRING HOOK										
31	544208-005	-	*	*	*	*	1	TRIMMER LEVER SET SCREW										

# THREAD TRIMMER 2

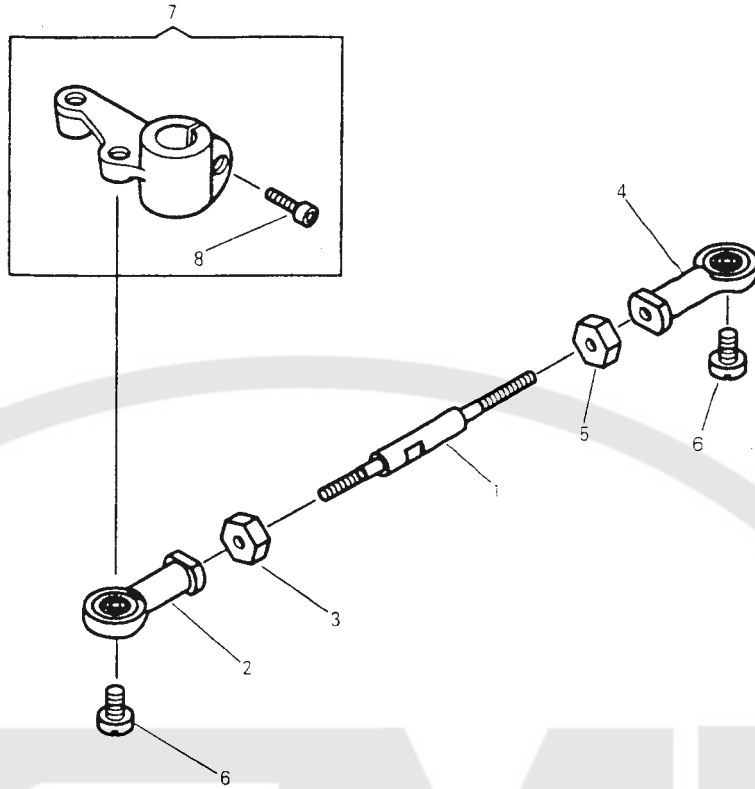

NO	PART NO.	157A	157J	157K	557A	557J	557K	QTY	DESCRIPTION
1	554654-001	-	-	*	*	*	*	1	TRIMMER ROD FOR DRIVING ARM
2	416781-101	-	-	*	*	*	*	1	TRIMMER ROD END (LEFT)
3	414774	-	-	*	*	*	*	1	TRIMMER ROD END (LEFT) NUT
4	416781-001	-	-	*	*	*	*	1	TRIMMER ROD END (RIGHT)
5	541166-001	-	-	*	*	*	*	1	TRIMMER ROD END (RIGHT) NUT
6	414775	-	-	*	*	*	*	2	TRIMMER ROD END SCREW
7	281074	-	*	*	*	*	*	1	THREAD PULLER DRIVING ARM COMPLETE
8	374107-004	-	*	*	-	*	*	1	THREAD PULLER DRIVING ARM SCREW

NO.	PART NO.	157A	157J	157K	557A	557J	557K	QTY	DESCRIPTION

# TENSION RELEASING

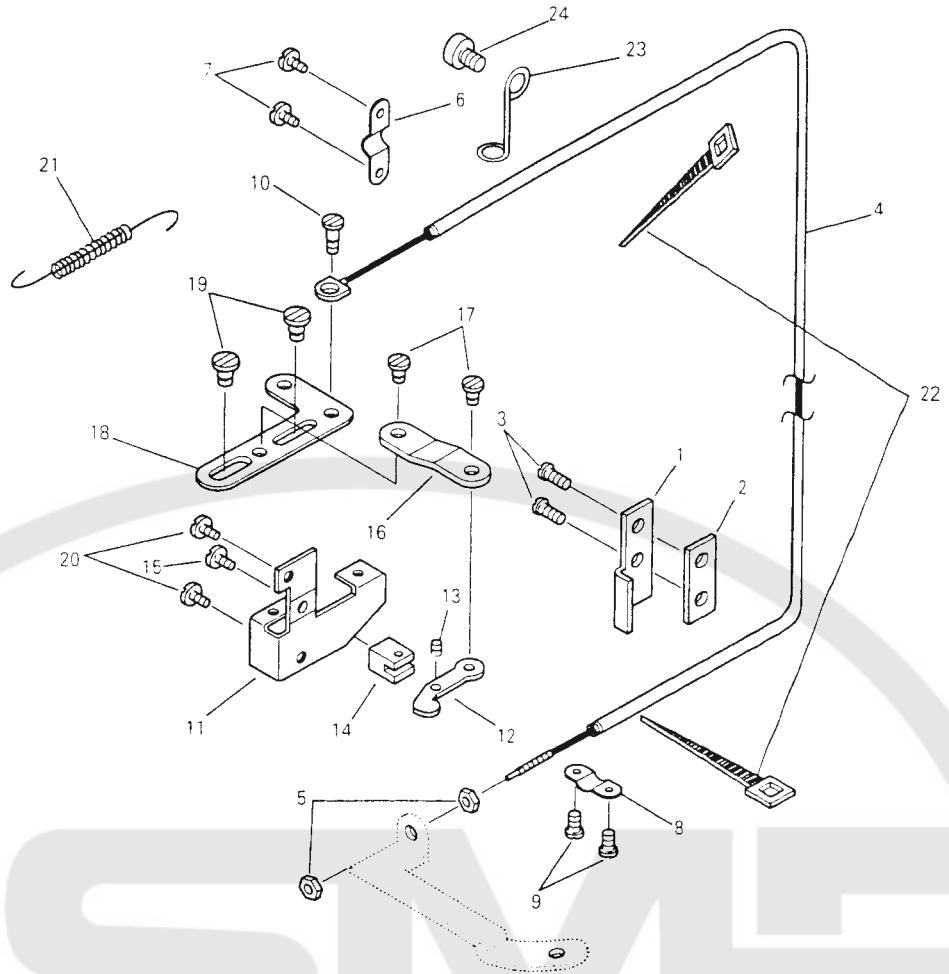

NO	PART NO.	157A	157J	157K	557A	557J	557K	Y	DESCRIPTION
1	552593	-	*	*	-	*	*	1	TENSION RELEASE DRIVING LEVER STOPPER
2	552594	-	*	*	-	*	*	1	TENSION RELEASE DRIVING LEVER STOPPER RETAINING PLATE
3	414780	-	*	*	-	*	*	2	TENSION RELEASE DRIVING LEVER STOPPER SCREW
4	552595	-	*	*	-	*	*	1	TENSION RELEASE WIRE GUIDE, TUBE COMPLETE
5	541166-003	-	*	*	-	*	*	2	TENSION RELEASE WIRE STAKING PIPE LOCK NUT
6	543327	-	*	*	-	*	*	1	TENSION RELEASE WIRE GUIDE TUBE CLAMPING PLATE (UPPER)
7	504010-452	-	*	*	-	*	*	2	TENSION RELEASE WIRE GUIDE TUBE CLAMPING PLATE (UPPER) SCREW
8	543327	-	*	*	-	*	*	1	TENSION RELEASE WIRE GUIDE TUBE CLAMPING PLATE (LOWER)
9	504010-452	-	*	*	-	*	*	2	TENSION RELEASE WIRE GUIDE TUBE CLAMPING PLATE (LOWER) SCREW
10	544144	-	*	*	-	*	*	1	TENSION RELEASE WIRE SHEAVE SCREW
11	552601	-	*	*	-	*	*	1	TENSION RELEASE LEVER BRACKET
12	552602	-	*	*	-	*	*	1	TENSION RELEASE LEVER
13	552603	-	*	*	-	*	*	1	TENSION RELEASE LEVER PIN
14	552604	-	*	*	-	*	*	1	TENSION RELEASE LEVER BLOCK
15	544256	-	*	*	-	*	*	1	TENSION RELEASE LEVER BLOCK SCREW
16	552605	-	*	*	-	*	*	1	TENSION RELEASE LEVER LINK
17	368247	-	*	*	-	*	*	2	TENSION RELEASE LEVER LINK HINGE SCREW
18	552606	-	*	*	-	*	*	1	TENSION RELEASE ACTUATING SLIDE PLATE
19	368247	-	*	*	-	*	*	2	TENSION RELEASE ACTUATING SLIDE PLATE HINGE SCREW
20	544213-052	-	*	*	-	*	*	2	TENSION RELEASE LEVER BRACKET SCREW
21	281593	-	*	*	-	*	*	1	TENSION RELEASE ACTUATING SLIDE PLATE SPRING

NO	PART NO.	157A	157J	157K	557A	557J	557K	Y	DESCRIPTION
22	540899	-	*	*	-	*	*	2	TENSION RELEASE WIRE GUIDE TUBE RETAINER
23	554833	-	*	*	-	*	*	1	TENSION RELEASE WIRE GUIDE TUBE SUPPRT
24	544213-002	-	*	*	-	*	*	1	TENSION RELEASE WIRE GUIDE TUBE SUPPRT SCREW

# BACK TACK MECHANISM

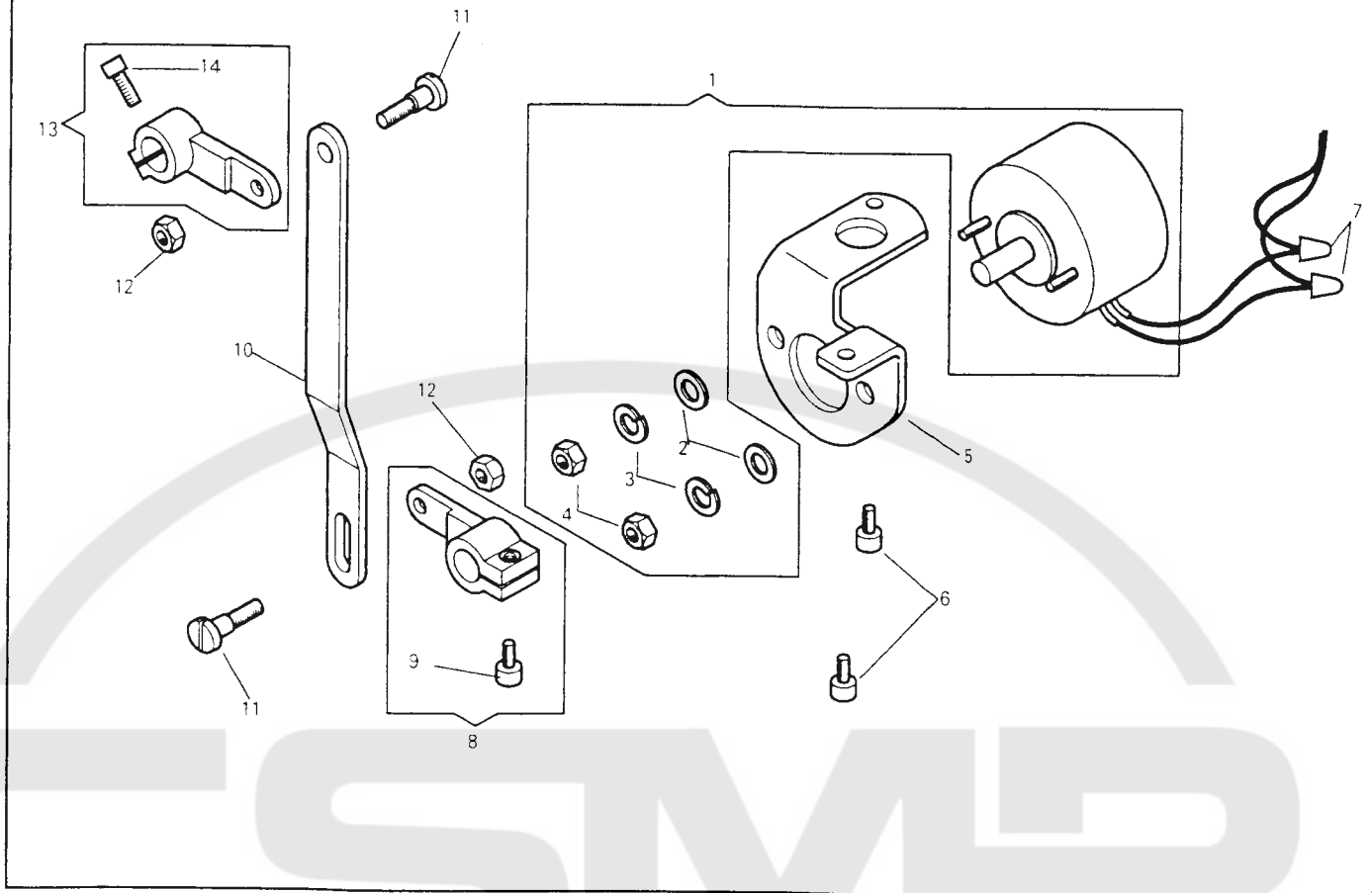

NO.	PART NO.	157A	157J	157K	557A	557J	557K	T Q Y	DESCRIPTION
1	369335	-	-	*	-	-	*	1	BACK TACK SOLENOID COMPLETE
2	543804-005	-	-	*	-	-	*	2	BACK TACK SOLENOID WASHER
3	543805-005	-	-	*	-	-	*	2	BACK TACK SOLENOID SPRING WASHER
4	541167-003	-	-	*	-	-	*	2	BACK TACK SOLENOID NUT
5	552609	-	-	*	-	-	*	1	BACK TACK SOLENOID BRACKET
6	374108-010	-	-	*	-	-	*	2	BACK TACK SOLENOID BRACKET SCREW
7	417142-001	-	-	*	-	-	*	2	BACK TACK SOLENOID WIRE CONNECTOR
8	552610	-	-	*	-	-	*	1	BACK TACK SOLENOID ARM COMPLETE
9	549183	-	-	*	-	-	*	1	BACK TACK SOLENOID ARM PINCH SCREW
10	552612	-	-	*	-	-	*	1	BACK TACK SOLENOID LINK
11	374546	-	-	*	-	-	*	2	BACK TACK SOLENOID LINK HINGE SCREW
12	545422	-	-	*	-	-	*	2	BACK TACK SOLENOID LINK HINGE SCREW NUT
13	552613	-	-	*	-	-	*	1	FEED REVERSE LEVER SHAFT
14	374107-004	-	-	*	-	-	*	1	ACTUATING ARM COMPLETE FEED REVERSE LEVER SHAFT ACTUATING ARM PINCH SCREW

NO.	PART NO.	157A	157J	157K	557A	557J	557K	T Q Y	DESCRIPTION

# BACK TACK SWITCH

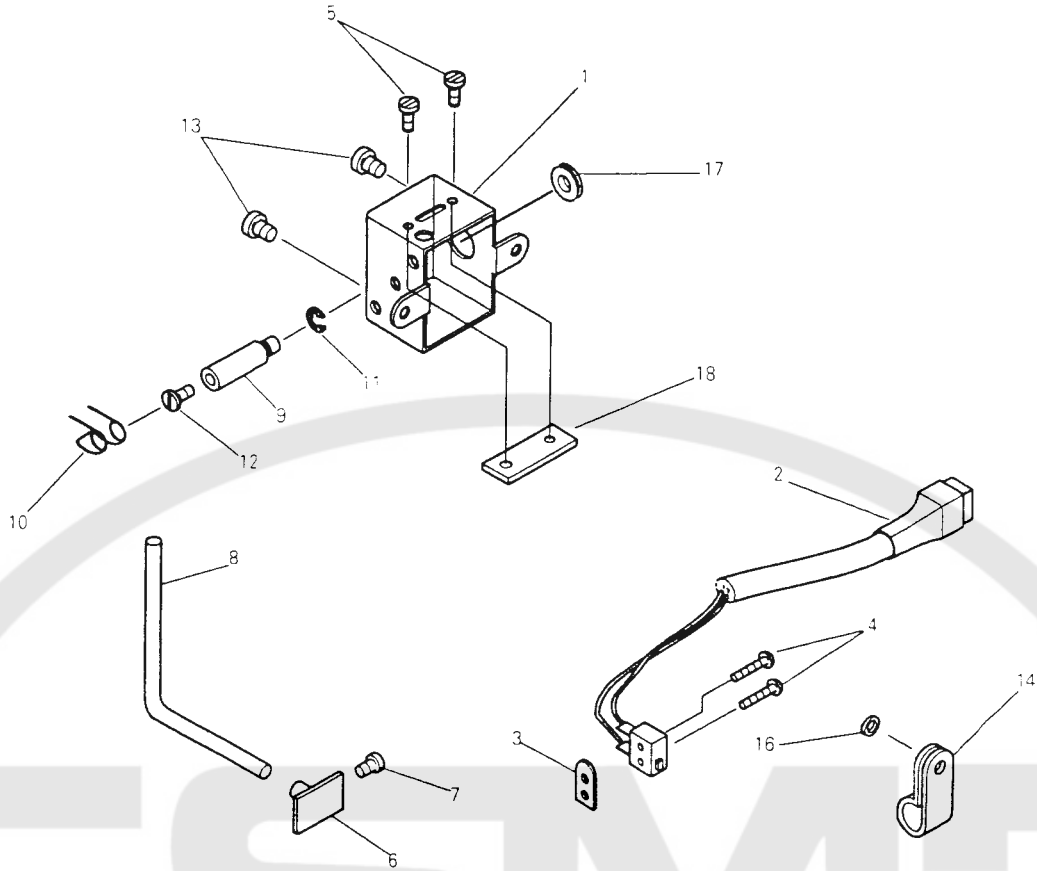

NO.	PART NO.						QTY	DESCRIPTION
		157A	157J	157K	557A	557J		
1	552616	-	-	*	-	*	1	BACK TACK SWITCH BOX
2	419125	-	-	*	-	*	1	BACK TACK SWITCH CORD, CONNECTOR COMP.
3	368467	-	-	*	-	*	1	BACK TACK SWITCH PLATE
4	544211-056	-	-	*	-	*	2	BACK TACK SWITCH PLATE SCREW
5	544211-001	-	-	*	-	*	2	BACK TACK SWITCH BOX COVER SCREW
6	376146	-	-	*	-	*	1	BACK TACK SWITCH LEVER BUTTON
7	374110-002	-	-	*	-	*	1	BACK TACK SWITCH LEVER BUTTON SCREW
8	552618	-	-	*	-	*	1	BACK TACK SWITCH LEVER
9	375733	-	-	*	-	*	1	BACK TACK SWITCH LEVER SHAFT
10	375732	-	-	*	-	*	1	BACK TACK SWITCH LEVER SPRING
11	543801-015	-	-	*	-	*	1	BACK TACK SWITCH LEVER SHAFT SNAP RING
12	545246-452	-	-	*	-	*	1	BACK TACK SWITCH LEVER SCREW
13	544217-052	-	-	*	-	*	2	BACK TACK SWITCH BOX SCREW
14	542766-005	-	-	*	-	*	1	BACK TACK SWITCH CORD CLIP
16	543803-002	-	-	*	-	*	1	BACK TACK SWITCH CORD CLIP WASHER
17	554884	-	-	*	-	*	1	BACK TACK SWITCH BOX GROMMETS
18	552784	-	-	*	-	*	1	BACK TACK SWITCH BOX COVER

NO.	PART NO.						QTY	DESCRIPTION
		157A	157J	157K	557A	557J		

GAUGE PARTS

Blank TP for ARTEX - lots of 200 is P/N 555145 (Price \$25.22) 10/98.

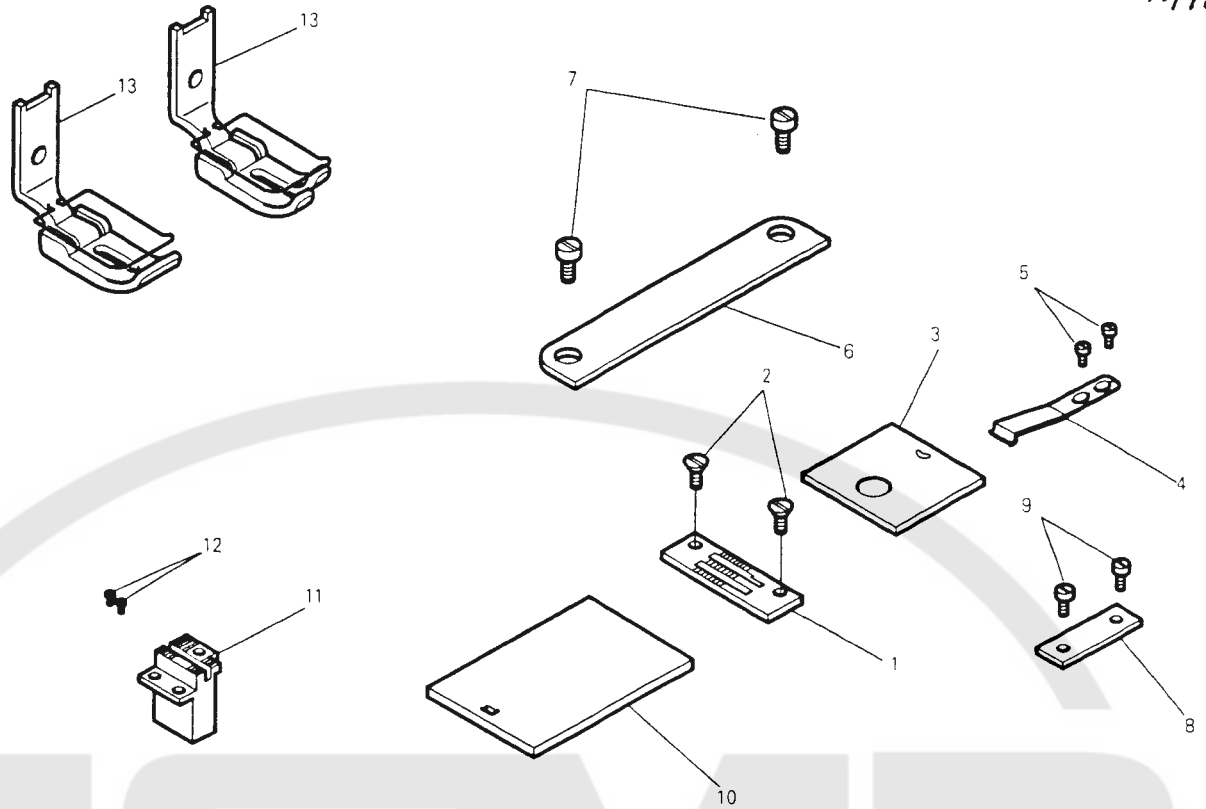

NO.	PART NO.	157A	157J	157K	557A	557J	557K	QTY	DESCRIPTION
1	503884-452	*	-	-	-	-	-	1	THROAT PLATE
1	281162	-	*	-	-	-	-	1	THROAT PLATE
2	691-845	-	-	*	-	-	-	2	THROAT PLATE SCREW
3	552677	*	*	*	*	*	*	1	BED SLIDE (RIGHT)
4	552419	*	*	*	*	*	*	1	BED SLIDE (RIGHT) SPRING PLATE
5	544289	*	*	*	*	*	*	2	BED SLIDE (RIGHT) SPRING PLATE SCREW
6	552678	-	-	*	-	-	-	1	BED COVER PLATE
7	545137	-	-	*	-	-	-	2	BED COVER PLATE (RIGHT) SCREW
8	554651	*	*	*	*	*	*	1	BED COVER PLATE
9	414659	*	*	*	*	*	*	2	BED COVER PLATE SCREW
10	419614-452	*	*	*	*	*	*	1	BED SLIDE (LEFT)
11	240259	*	-	-	-	-	-	1	FEED DOG
11	281163	-	*	-	-	-	-	1	FEED DOG
12	544399	*	*	*	*	*	*	2	FEED DOG SCREW
13	554887	*	-	-	-	-	-	1	PRESSER FOOT COMP.
13	554968	-	*	*	-	-	-	1	PRESSER FOOT COMP.

NO.	PART NO.	157A	157J	157K	557A	557J	557K	QTY	DESCRIPTION



# ACCESSORIES AND ATTACHMENTS 1

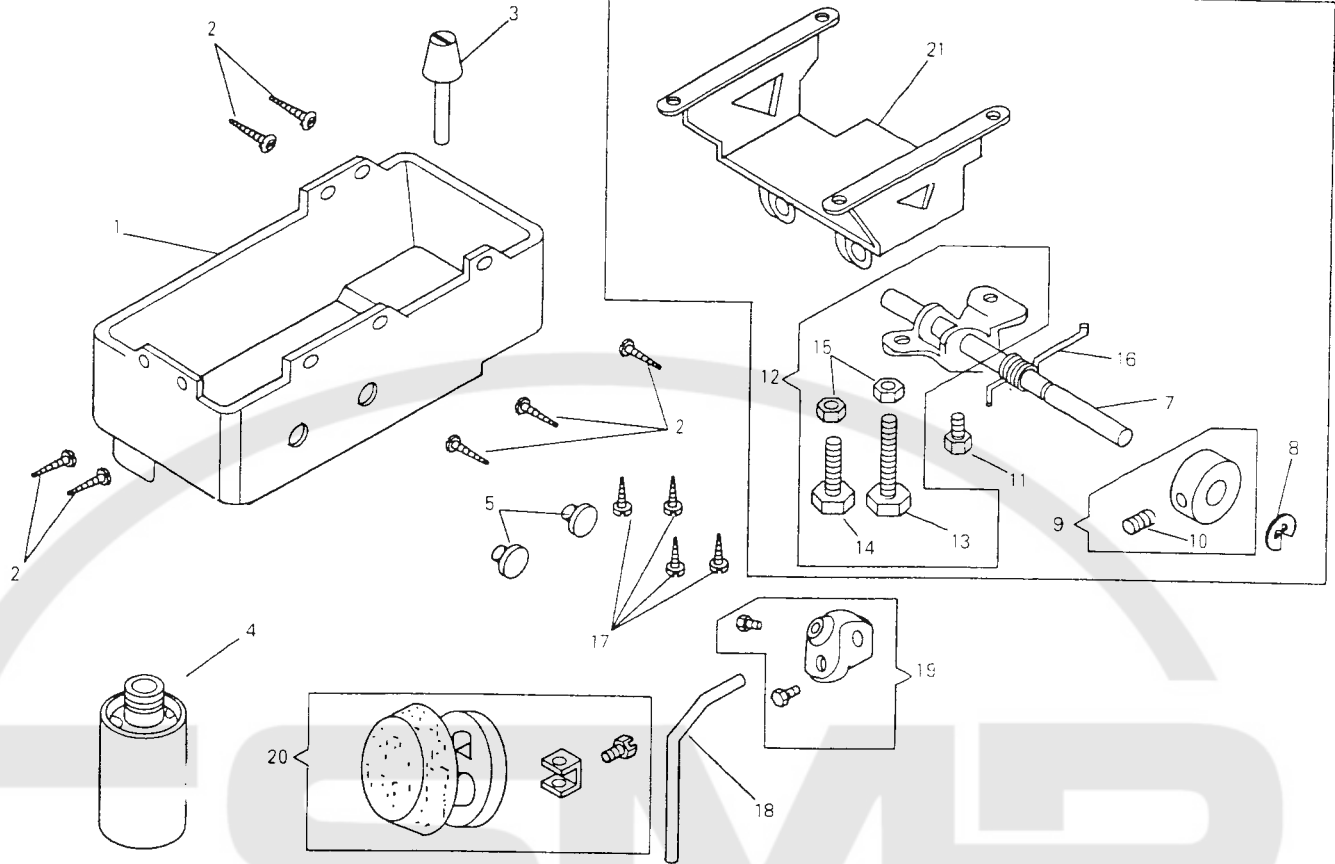

NO.	PART NO.	157A	157J	157K	557A	557J	557K	QTY	DESCRIPTION
		*	*	*	*	*	*		
1	552647	*	*	*	*	*	*	1	DRIP PAN
2	350708	*	*	*	*	*	*	7	DRIP PAN NAIL
3	552648	*	*	*	*	*	*	1	KNEE LIFTER PLUNGER COMP.
4	167448	*	*	*	*	*	*	1	DRIP PAN DRAIN JAR
5	544886-451	*	*	*	*	*	*	2	DRIP PAN RUBBER PLUG
7	552644	*	*	*	*	*	*	1	KNEE LIFTER ROCK SHAFT
8	543801-011	*	*	*	*	*	*	1	KNEE LIFTER ROCK SHAFT RETAINING RING
9	540633	*	*	*	*	*	*	1	KNEE LIFTER ROCK SHAFT COLLAR
10	504134	*	*	*	*	*	*	1	KNEE LIFTER ROCK SHAFT COLLAR SET SCREW
11	544499-003	*	*	*	*	*	*	1	KNEE LIFTER ROCK SHAFT LIFTING ARM SCREW
12	552645	*	*	*	*	*	*	1	KNEE LIFTER ROCK SHAFT LIFTING ARM COMP.
13	544499-008	*	*	*	*	*	*	1	KNEE LIFTER ROCK SHAFT LIFTING ARM STOP SCREW (LONG)
14	544499-006	*	*	*	*	*	*	1	KNEE LIFTER ROCK SHAFT LIFTING ARM STOP SCREW (SMALL)
15	541167-001	*	*	*	*	*	*	2	KNEE LIFTER ROCK SHAFT LIFTING ARM STOP SCREW NUT
16	552646	*	*	*	*	*	*	1	KNEE LIFTER ROCK SHAFT LIFTING ARM SPRING
17	549296	*	*	*	*	*	*	4	KNEE LIFTER ROCK SHAFT BRACKET SCREW
18	544895	*	*	*	*	*	*	1	KNEE LIFTER ROCK SHAFT
19	545918	*	*	*	*	*	*	1	KNEE LIFTER ROCK SHAFT HUB COMP.
20	414115	*	*	*	*	*	*	1	KNEE LIFTER KNEE PLATE COMP.
21	552808	*	*	*	*	*	*	1	KNEE LIFTER ROCK SHAFT BRACKET

NO.	PART NO.	157A	157J	157K	557A	557J	557K	QTY	DESCRIPTION
		*	*	*	*	*	*		

# ACCESSORIES AND ATTACHMENTS 2

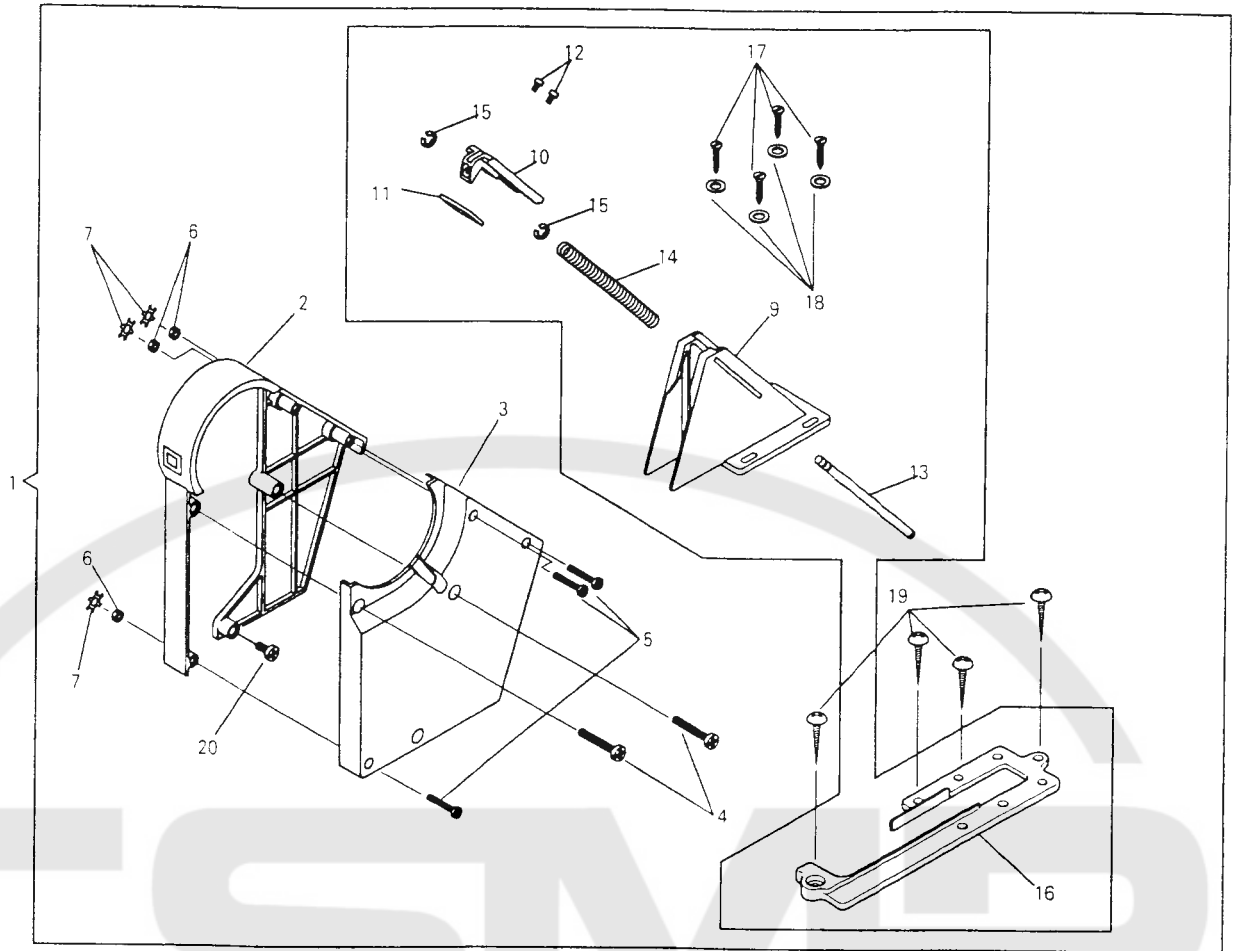

NO.	PART NO.	157A	157J	157K	557A	557J	557K	QTY	DESCRIPTION
		*	*	*	*	*	*		
1	552643-383	*	*	*	*	*	*	1	BELT GUARD COMP.
2	550163-451	*	*	*	*	*	*	1	BELT GUARD (LEFT)
3	550164-451	*	*	*	*	*	*	1	BELT GUARD (RIGHT)
4	544213-058	*	*	*	*	*	*	2	BELT GUARD SCREW
5	544212-007	*	*	*	*	*	*	3	BELT GUARD SCREW
6	541165-001	*	*	*	*	*	*	3	BELT GUARD SCREW NUT
7	543880-004	*	*	*	*	*	*	3	BELT GUARD SCREW NUT RING
9	550166-451	*	*	*	*	*	*	1	BELT GUARD (LOWER)
10	552820-383	*	*	*	*	*	*	1	BELT GUARD SLIDE
11	552821	*	*	*	*	*	*	1	BELT GUARD SLIDE PLATE
12	544211-053	*	*	*	*	*	*	2	BELT GUARD SLIDE SCREW
13	550169	*	*	*	*	*	*	1	BELT GUARD SLIDE SHAFT
14	368279	*	*	*	*	*	*	1	BELT GUARD SLIDE SPRING
15	408913	*	*	*	*	*	*	2	BELT GUARD SLIDE SHAFT SNAP RING
16	552819-383	*	*	*	*	*	*	1	BELT GUARD (LOWER) SPACER
17	412697-002	*	*	*	*	*	*	4	BELT GUARD (LOWER) WOOD SCREW
18	543804-003	*	*	*	*	*	*	4	BELT GUARD (LOWER) WOOD SCREW WASHER
19	549398	*	*	*	*	*	*	4	BELT GUARD (LOWER) SPACER WOOD SCREW
20	544213-053	*	*	*	*	*	*	1	BELT GUARD SCREW

NO.	PART NO.	157A	157J	157K	557A	557J	557K	QTY	DESCRIPTION

# ACCESSORIES AND ATTACHMENTS 3

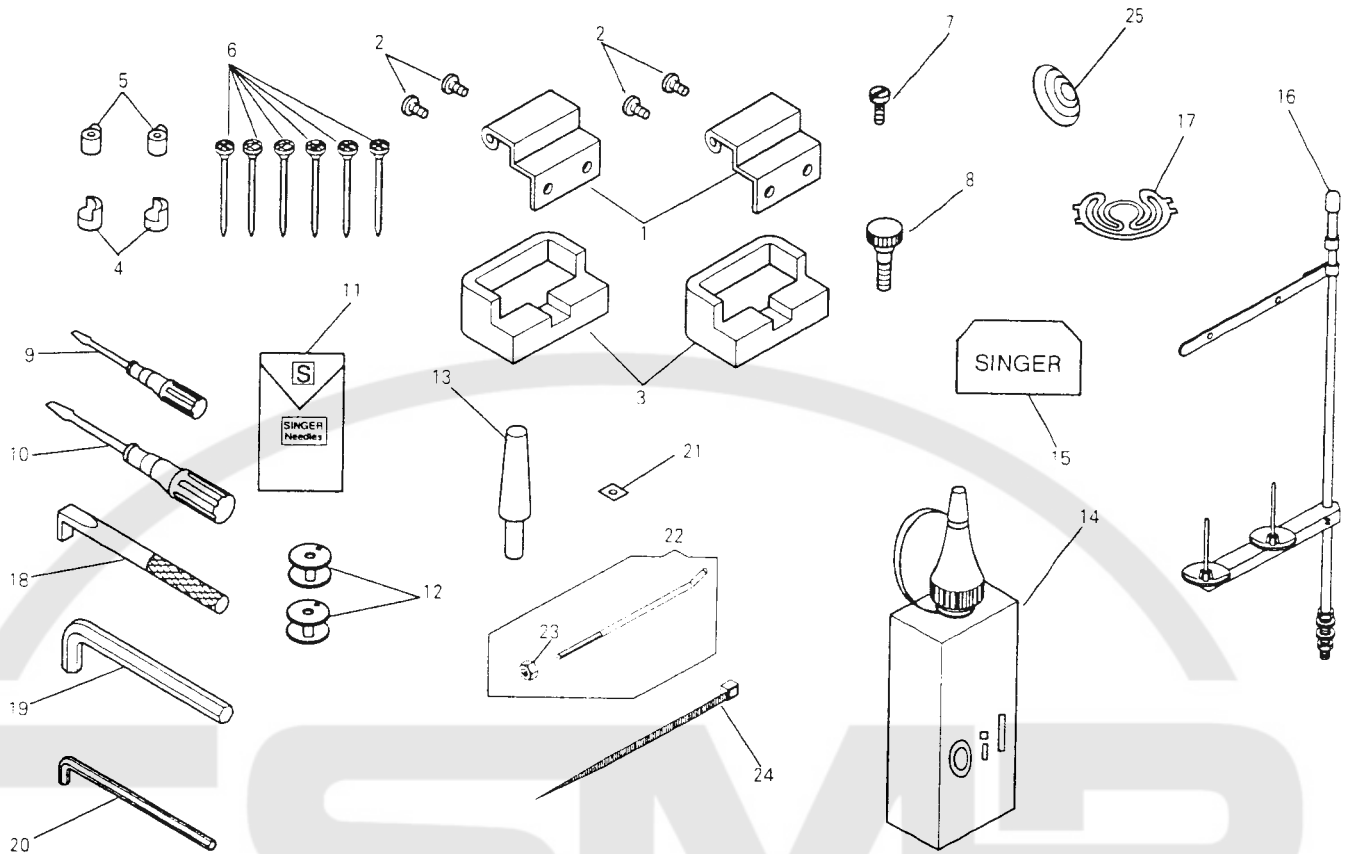

NO	PART NO.	SINGER					QTY	DESCRIPTION
		157A	157J	157K	557A	557J		
1	412212	*	*	*	*	*	2	MACHINE HINGE CONNECTION
2	544381	*	*	*	*	*	4	MACHINE HINGE CONNECTION SCREW
3	540523	*	*	*	*	*	2	MACHINE HINGE CONNECTION CUSHION
4	410570	*	*	*	*	*	2	MACHINE REST (FRONT)
5	410571	*	*	*	*	*	2	MACHINE REST (BACK)
6	546920-002	*	*	*	*	*	6	NAIL
7	545295	*	*	*	*	*	1	ATTACHMENT SCREW (SMALL)
8	544361	*	*	*	*	*	1	BED SLIDE THUMB SCREW
9	541514	*	*	*	*	*	1	SCREW DRIVER (SMALL)
10	548701	*	*	*	*	*	1	SCREW DRIVER (LONG)
11	N19550-121	*	*	*	*	*	5	NEEDLE (CAT NO. 1955-01 #21)
12	282762	*	*	*	*	*	2	BOBBIN
12	282763	*	*	*	*	*	2	BOBBIN
12	282764	*	*	*	*	*	2	BOBBIN
13	411313	*	*	*	*	*	1	MACHINE REST PIN
14	412181	*	*	*	*	*	1	OILER (250CC. C-TYPE)
15	414407	*	*	*	*	*	1	MACHINE COVER
16	376392-453	*	*	*	*	*	1	THREAD UNWINDER COMP.
17	417195	*	*	*	*	*	1	ANTI SPILL SPRING
17	417269	*	*	*	*	*	1	ANTI SPILL SPRING
18	368444	*	*	*	*	*	1	SCREW DRIVER
19	543066-001	*	*	*	*	*	1	WRENCH (FOR M4)
20	418441-001	*	*	*	*	*	1	WRENCH (FOR M3)
21	548228	*	*	*	*	*	1	TRAPPER ADJUSTING WASHER
22	281199	*	*	*	*	*	1	SENSOR RETAINER COMP.
23	541196	*	*	*	*	*	1	SENSOR RETAINER LOCK NUT
24	540899	*	*	*	*	*	1	CORD RETAINER
25	554741	*	*	*	*	*	1	TENSION SPRING

NO.	PART NO.	SINGER					QTY	DESCRIPTION
		157A	157J	157K	557A	557J		

PARTS AVAILABLE AT EXTRA CHARGE

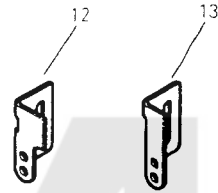
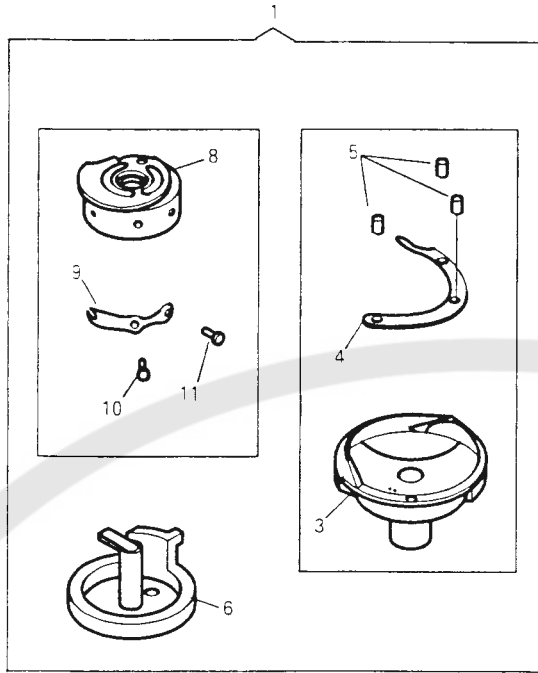

NO.	PART NO.	157A	157J	157K	557A	557J	557K	Y	T	Q	DESCRIPTION
		*	*	*	*	*	*				
1	554605	*	*	*	*	*	*	1			HOOK AND BOBBIN CASE COMP.
1	554610	*	*	*	*	*	*	1			HOOK AND BOBBIN CASE COMP
3	554607	*	*	*	*	*	*	1			HOOK (BODY)
3	554612	*	*	*	*	*	*	1			HOOK (BODY)
4	281135	*	*	*	*	*	*	1			HOOK GIB
4	412311	*	*	*	*	*	*	1			HOOK GIB
5	201253	*	*	*	*	*	*	2			HOOK GIB SCREW
5	500520	*	*	*	*	*	*	3			HOOK GIB SCREW
6	281138	*	*	*	*	*	*	1			BOBBIN CASE COMP.
6	281148	*	*	*	*	*	*	1			BOBBIN CASE COMP.
8	552879	*	*	*	*	*	*	1			BOBBIN CASE CAP
8	554614	*	*	*	*	*	*	1			BOBBIN CASE CAP
9	281143	*	*	*	*	*	*	1			BOBBIN CASE CAP TENSION SPRING
9	281149	*	*	*	*	*	*	1			BOBBIN CASE CAP TENSION SPRING
10	200984	*	*	*	*	*	*	1			BOBBIN CASE CAP TENSION SPRING
10	500519	-	-	-	*	*	*	1			REGULATING SCREW
11	200594	*	*	*	-	-	-	1			BOBBIN CASE CAP TENSION SPRING
11	500518	-	-	-	*	*	*	1			BOBBIN CASE TENSION SPRING
12	554681	*	*	*	-	-	-	1			ARM THREAD GUIDE
13	554082	-	-	-	*	*	*	1			ARM THREAD GUIDE

NO.	PART NO.	157A	157J	157K	557A	557J	557K	Y	T	Q	DESCRIPTION