

A large, light gray watermark of the Singer logo is centered on the page. It consists of a semi-circular arch at the top and bottom, with the word 'SINGER' in a bold, sans-serif font in the middle. Below 'SINGER' are the model numbers '31K19, K21, K47' in a smaller, bold, sans-serif font. The entire logo is rendered in a light gray color.

SINGER
31K19, K21, K47

CSMP

ILLUSTRATED
LIST OF PARTS

FOR

Nos. 31K19, 31K21 and 31K47
MACHINES



**A Trade Mark of THE SINGER MANUFACTURING COMPANY

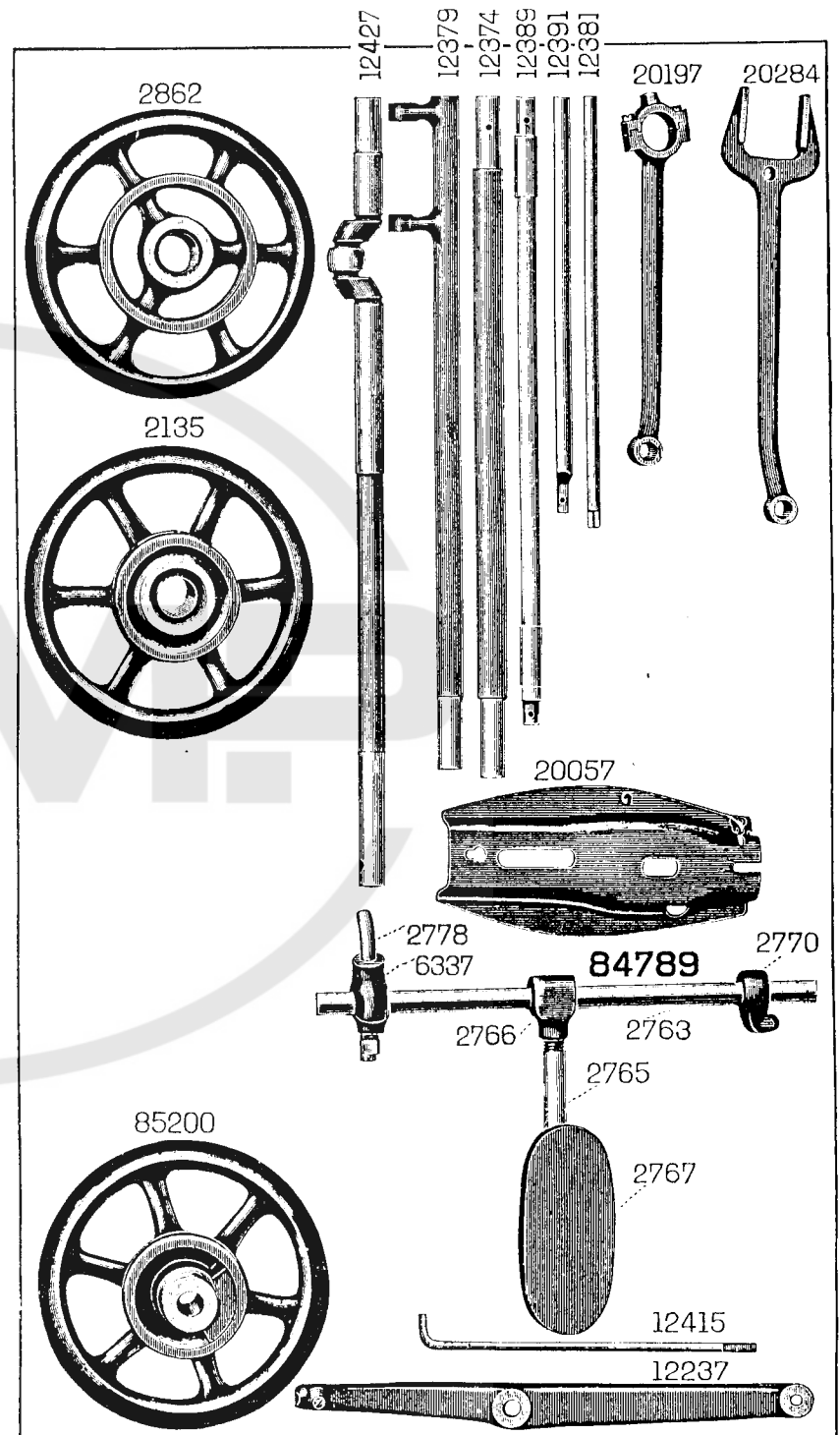

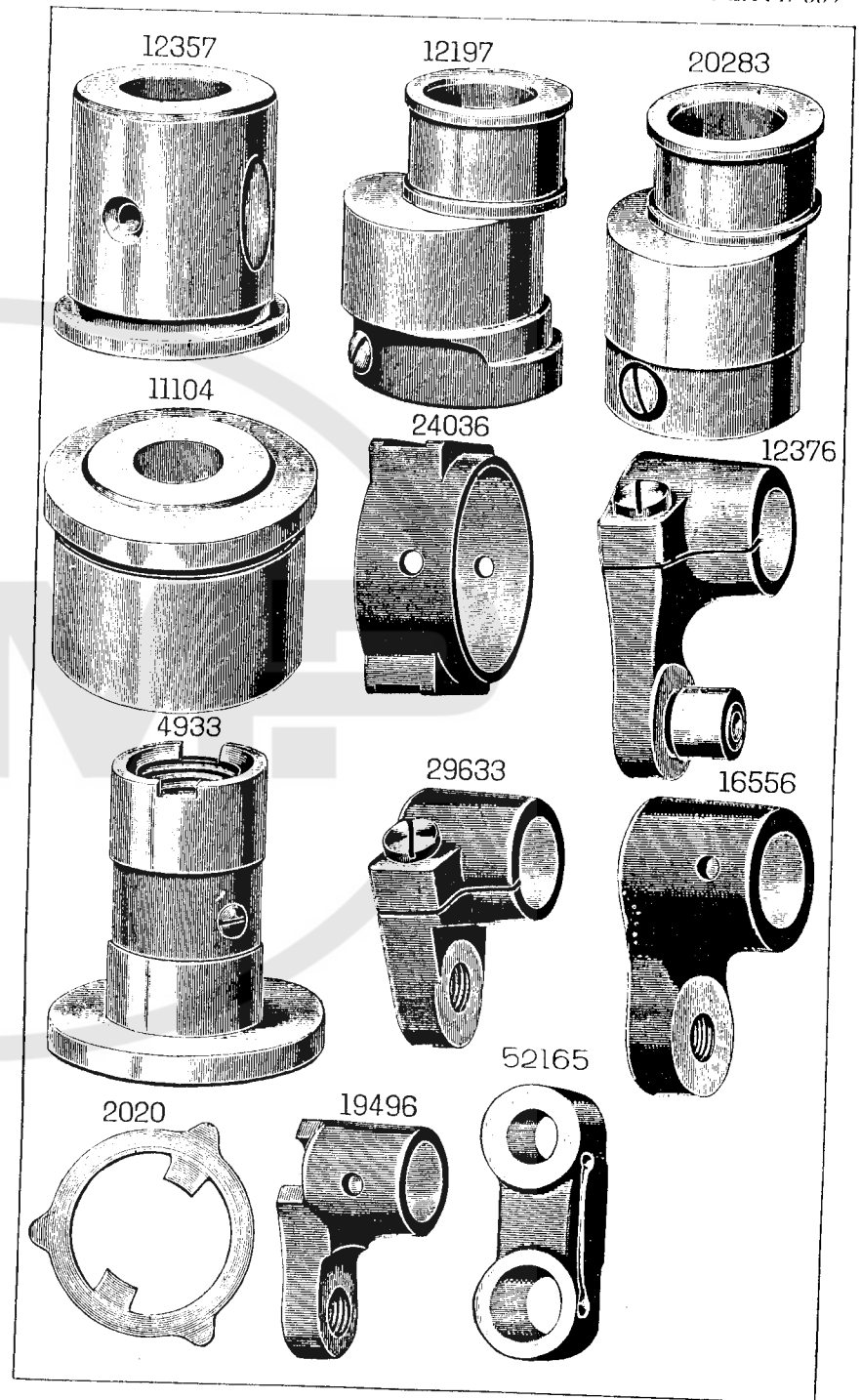
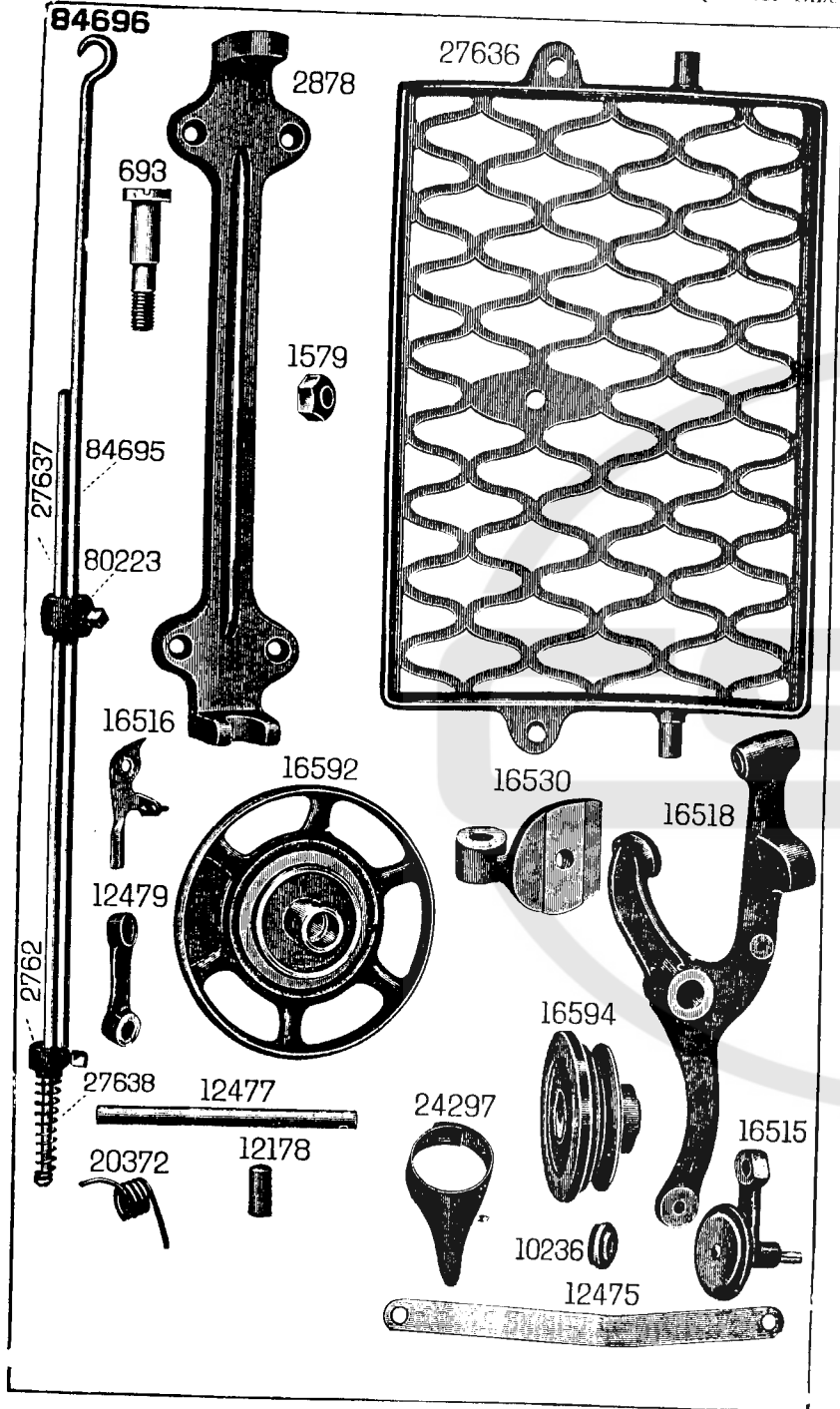

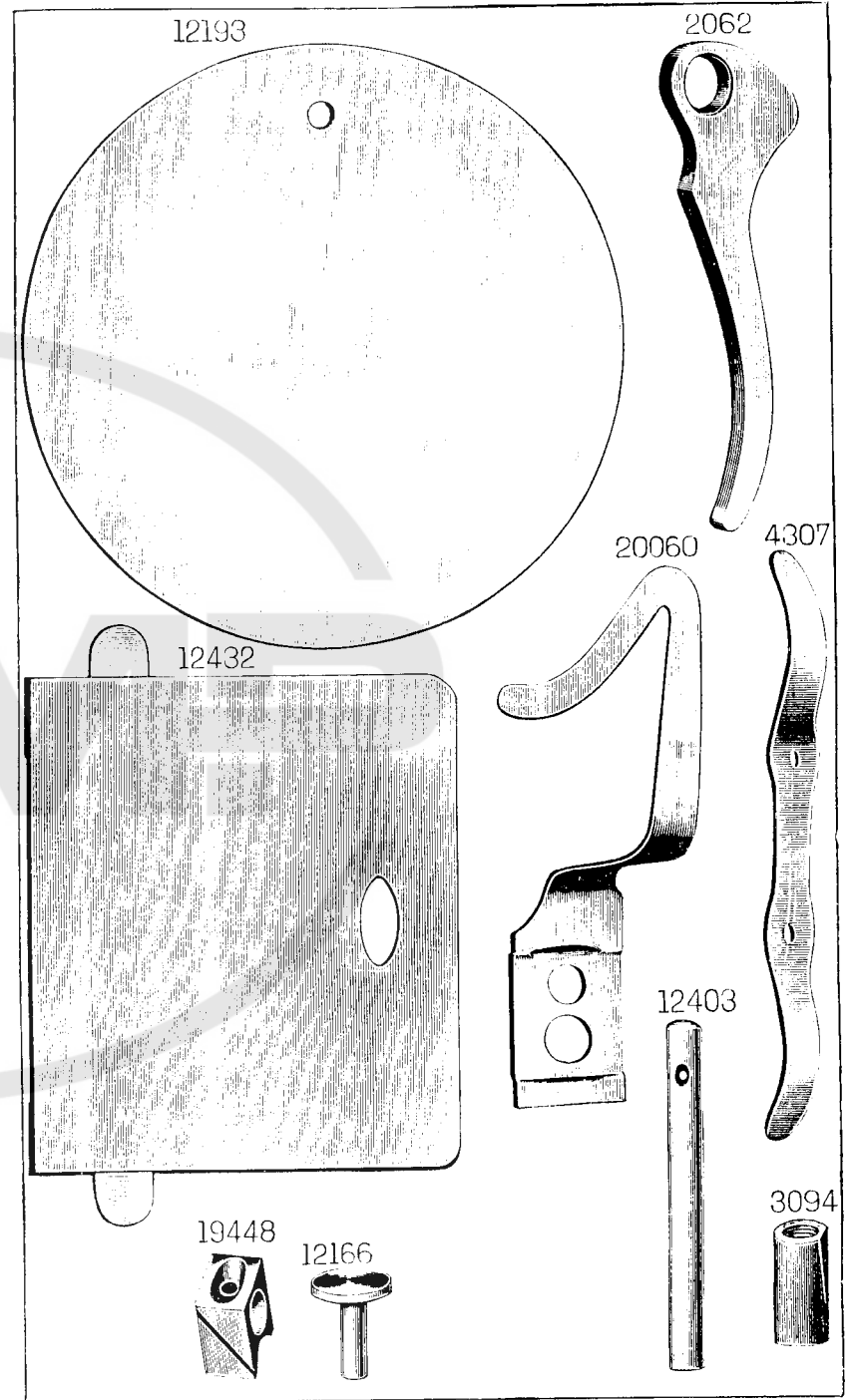
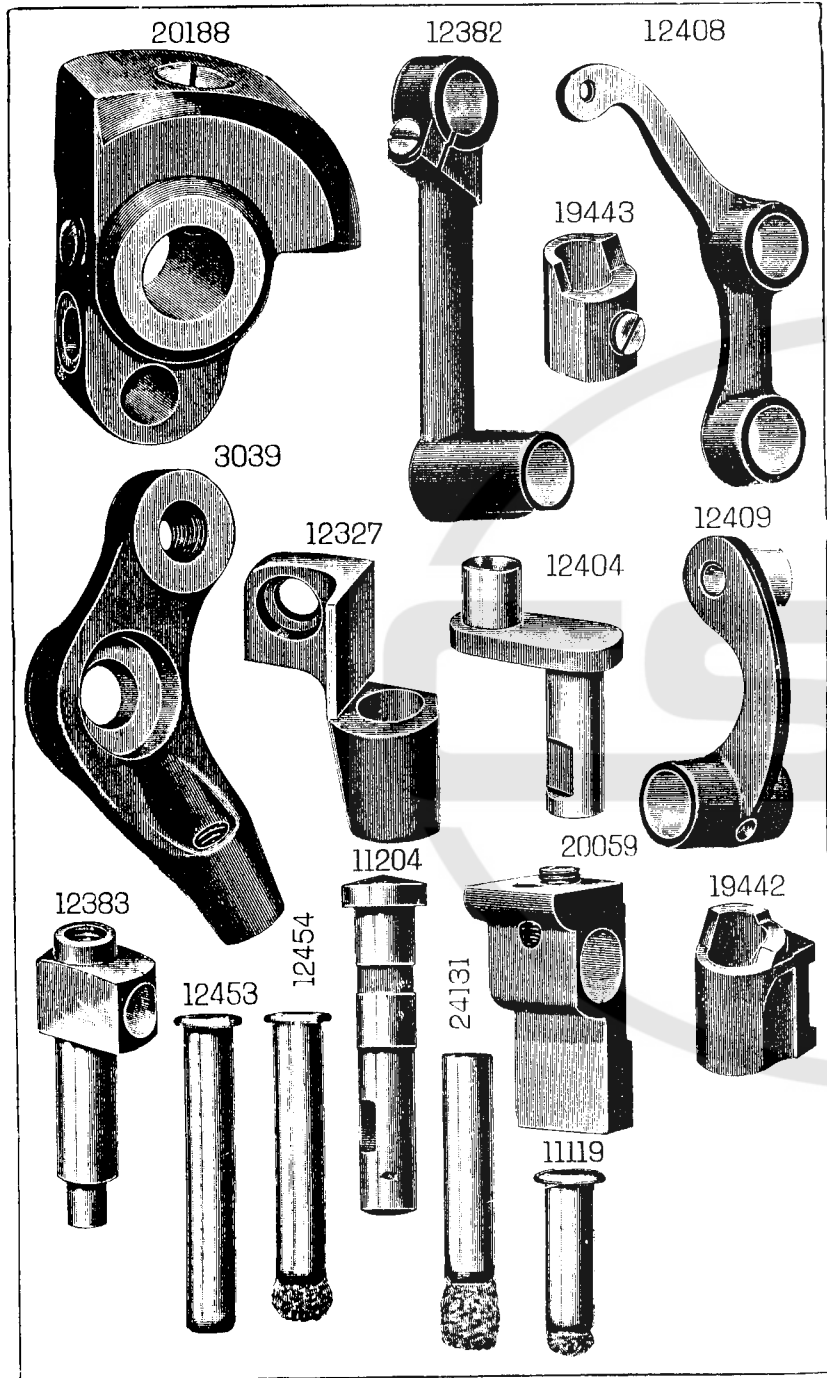

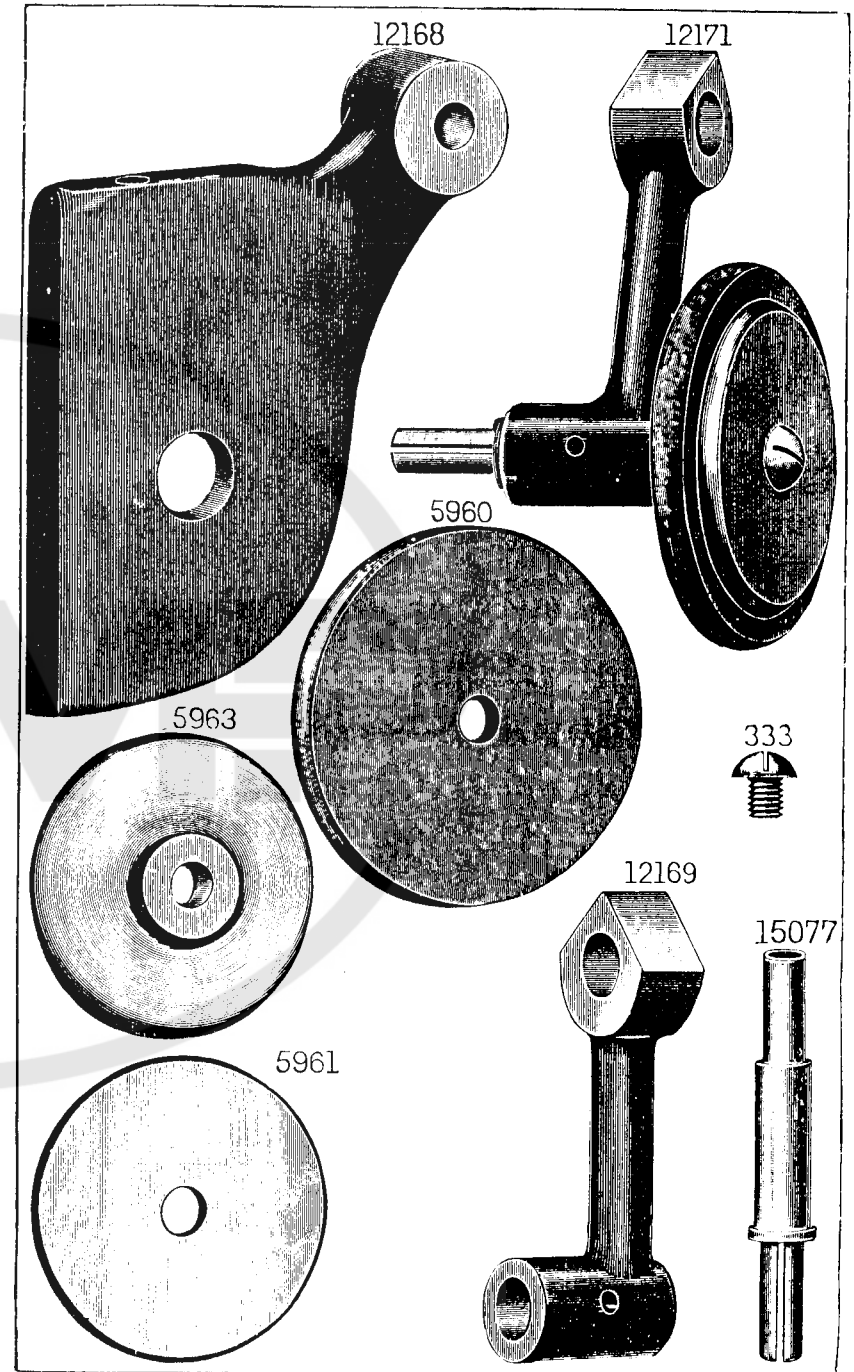
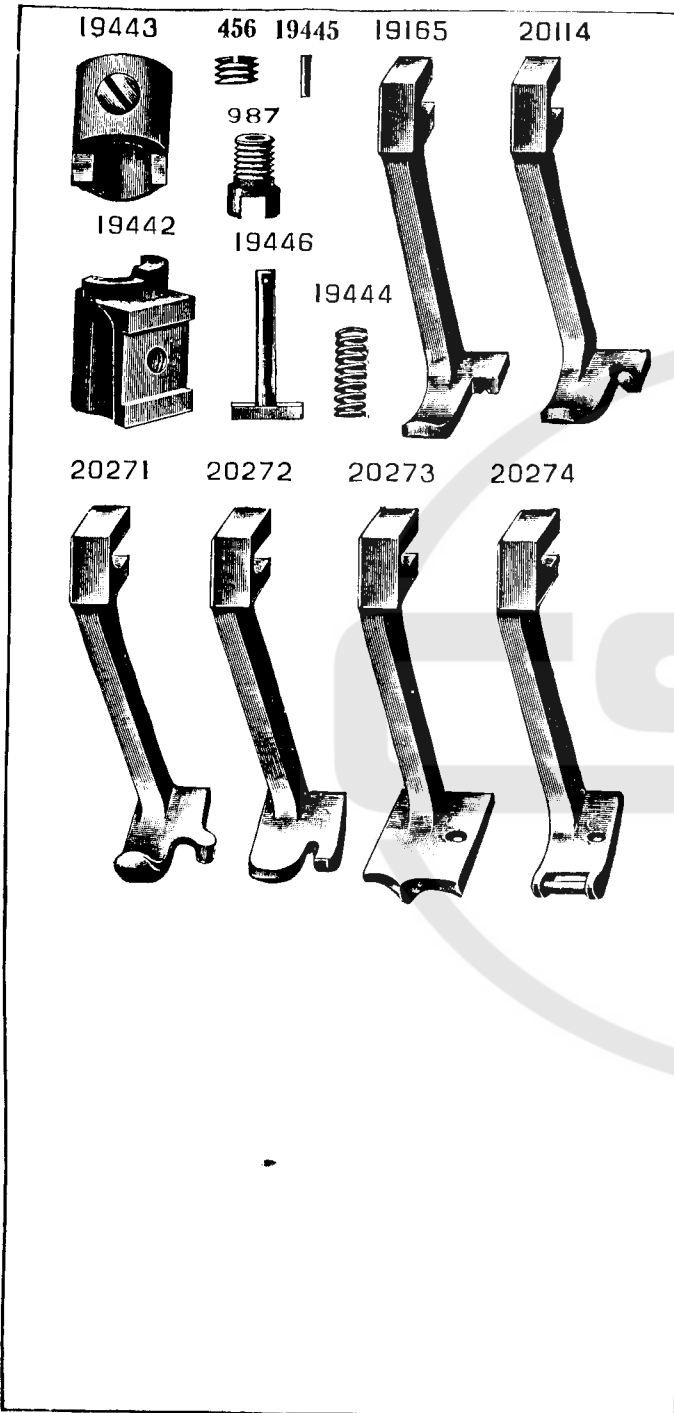

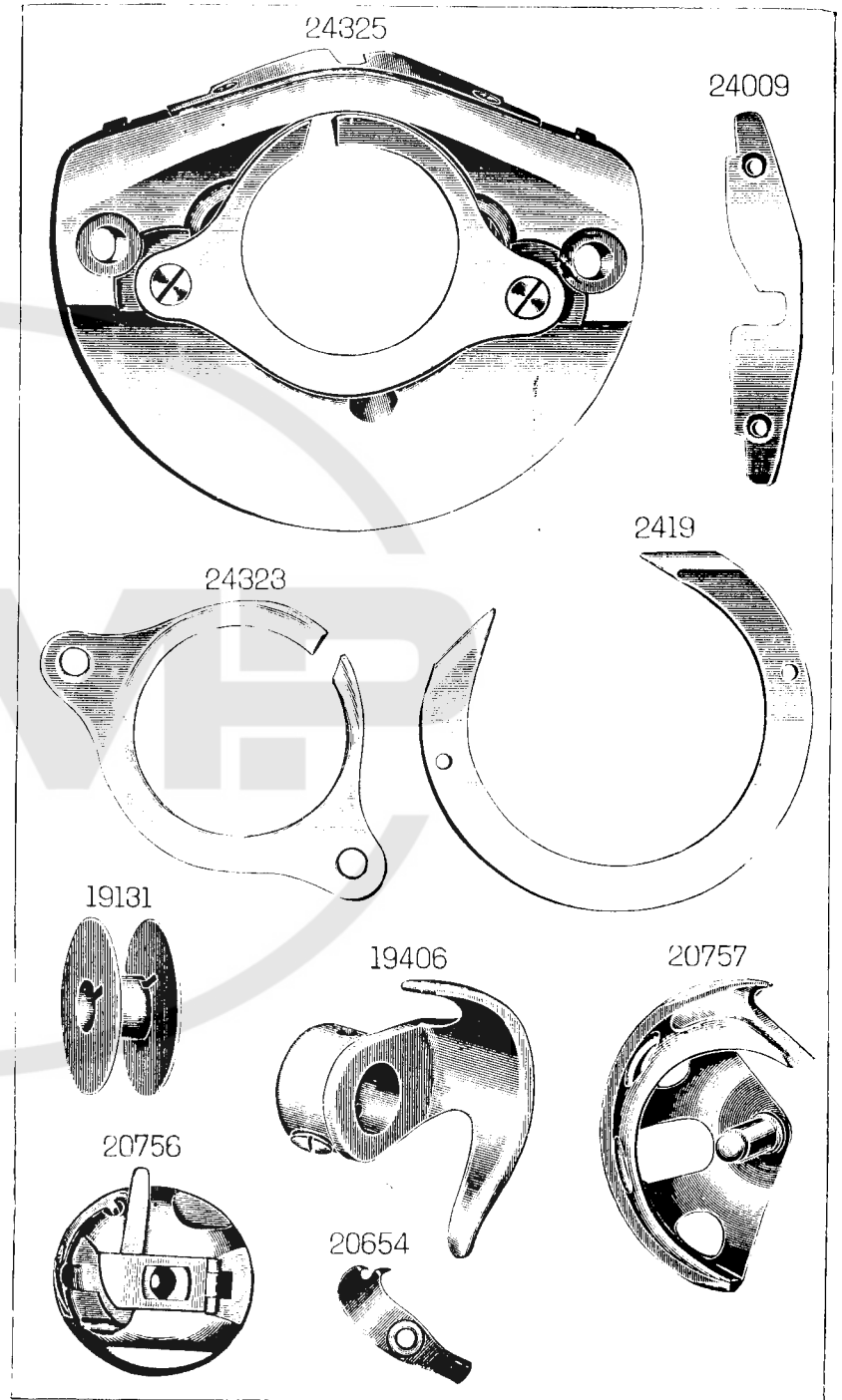
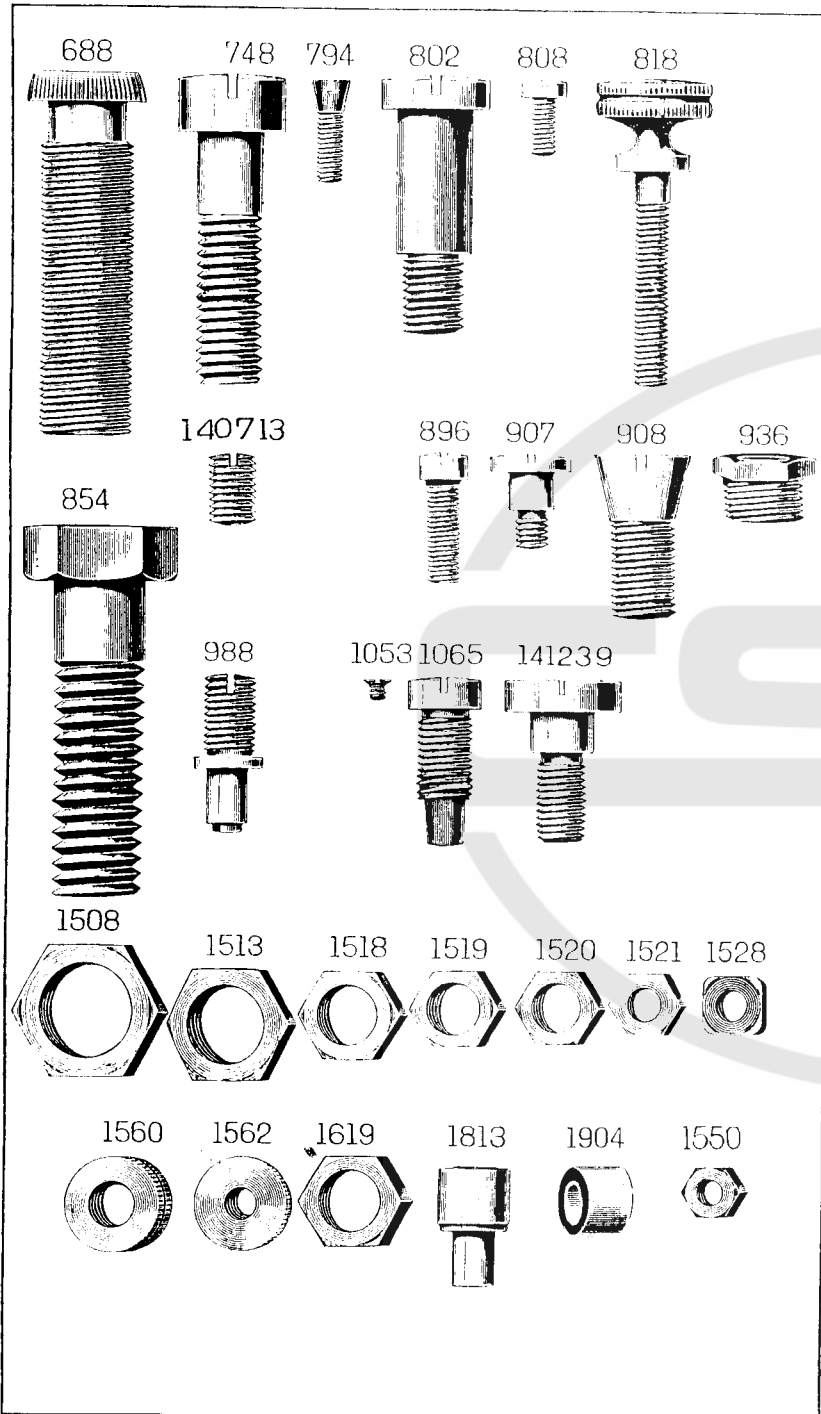

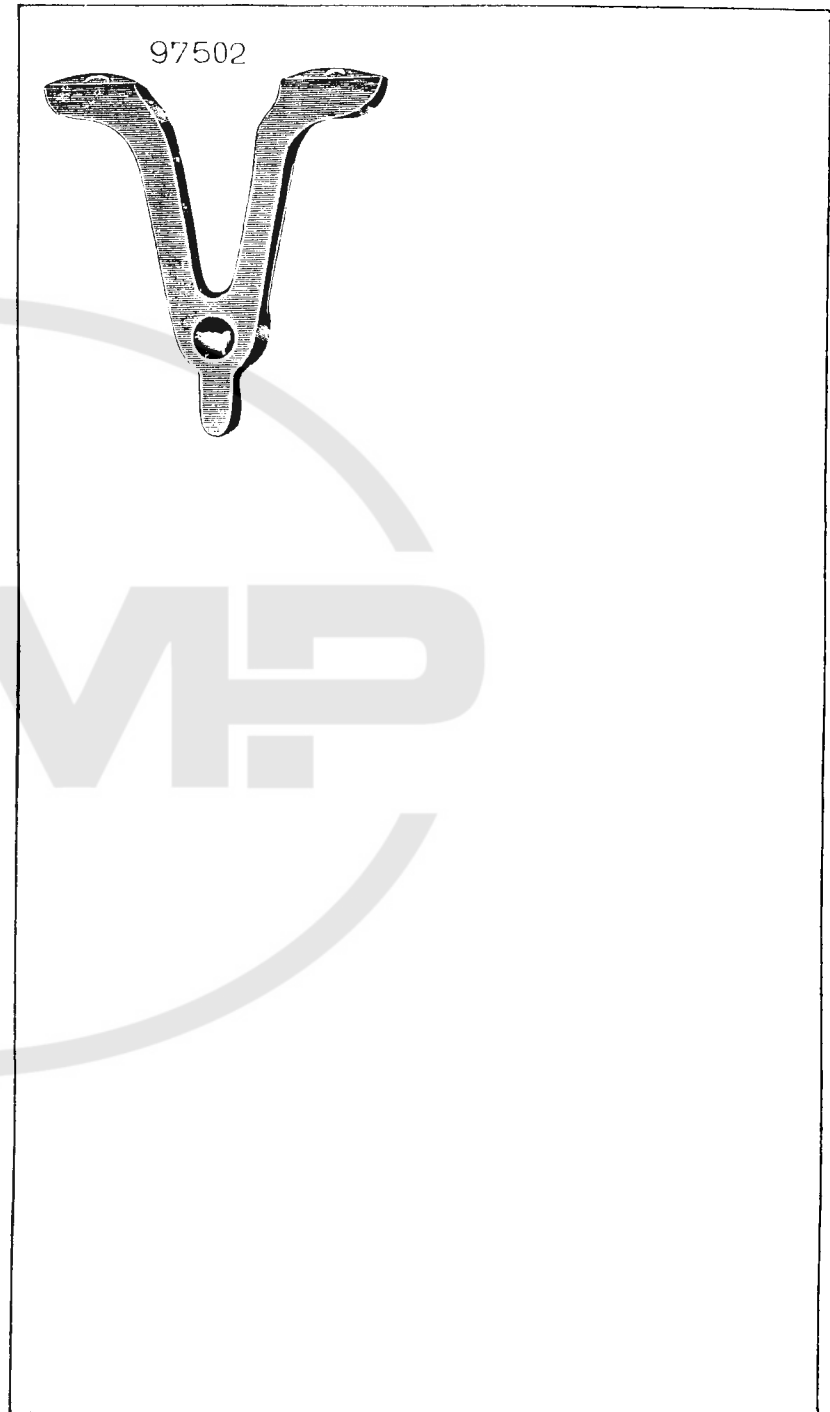
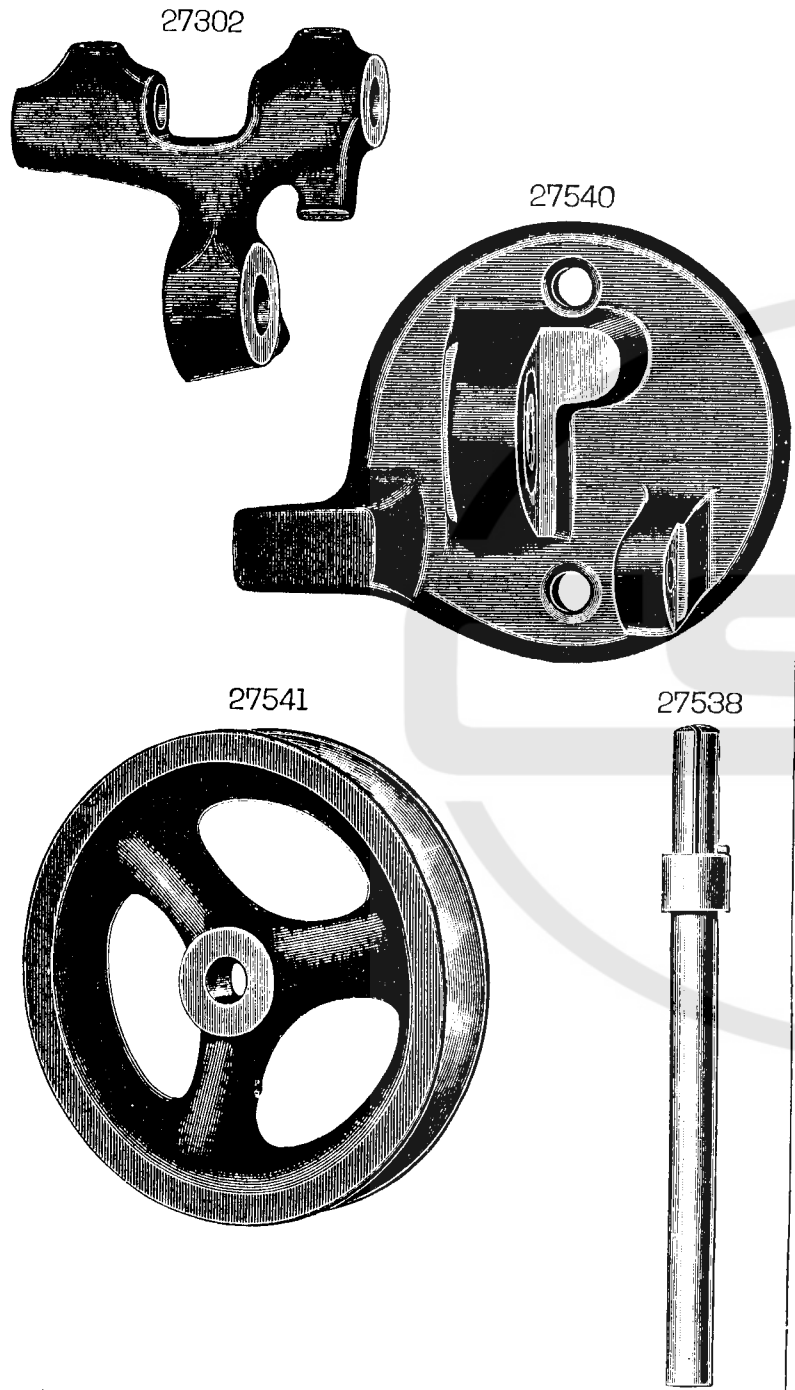

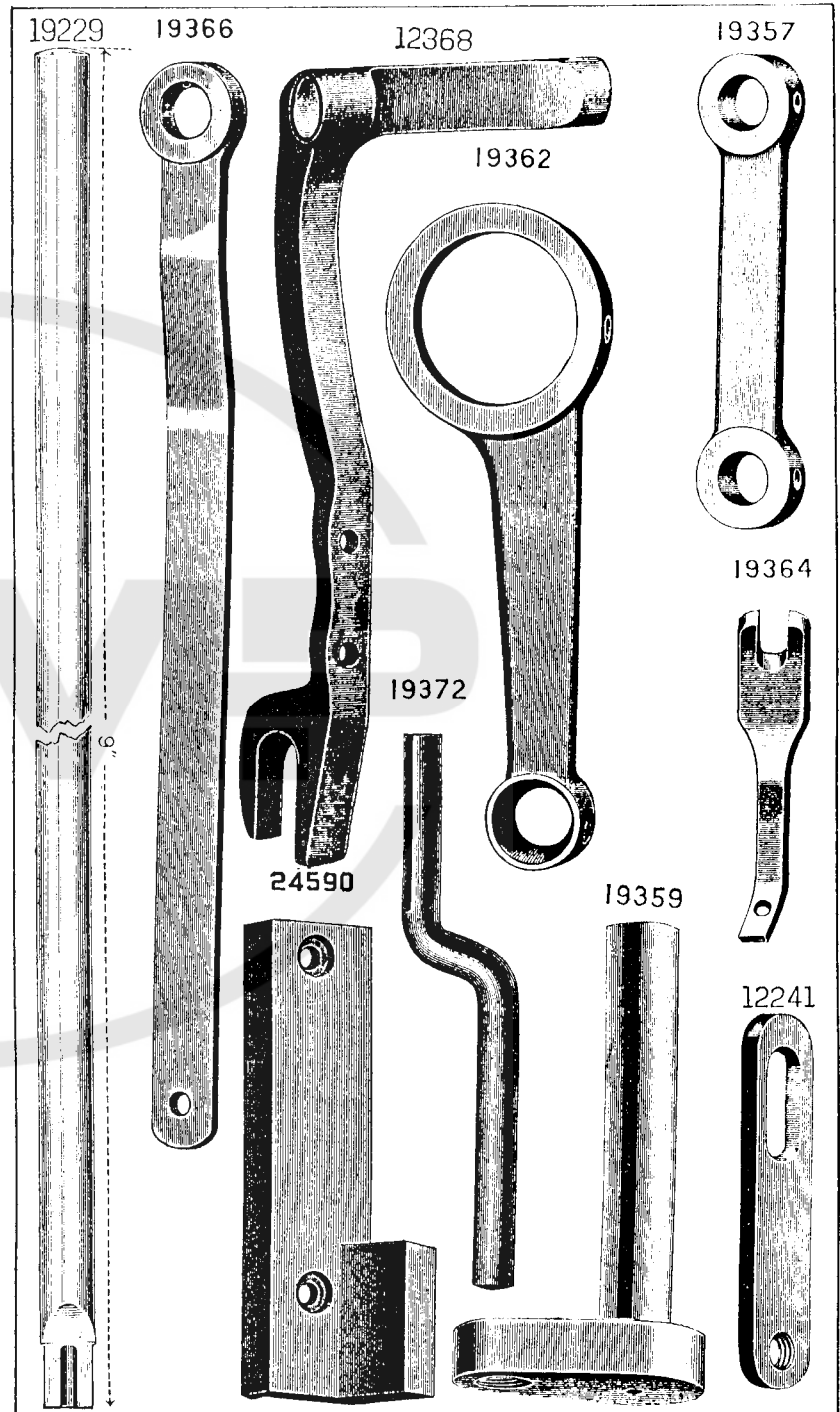
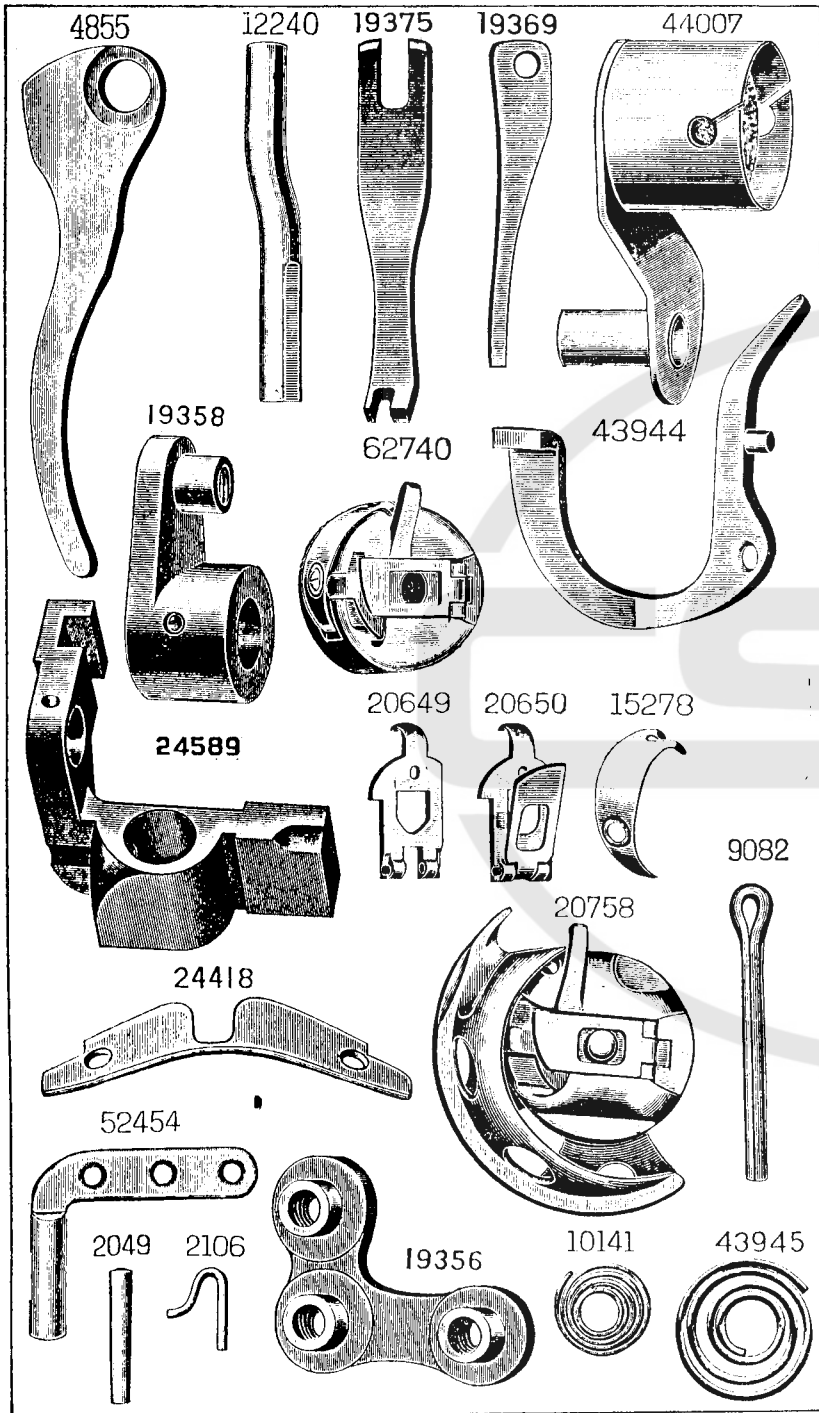

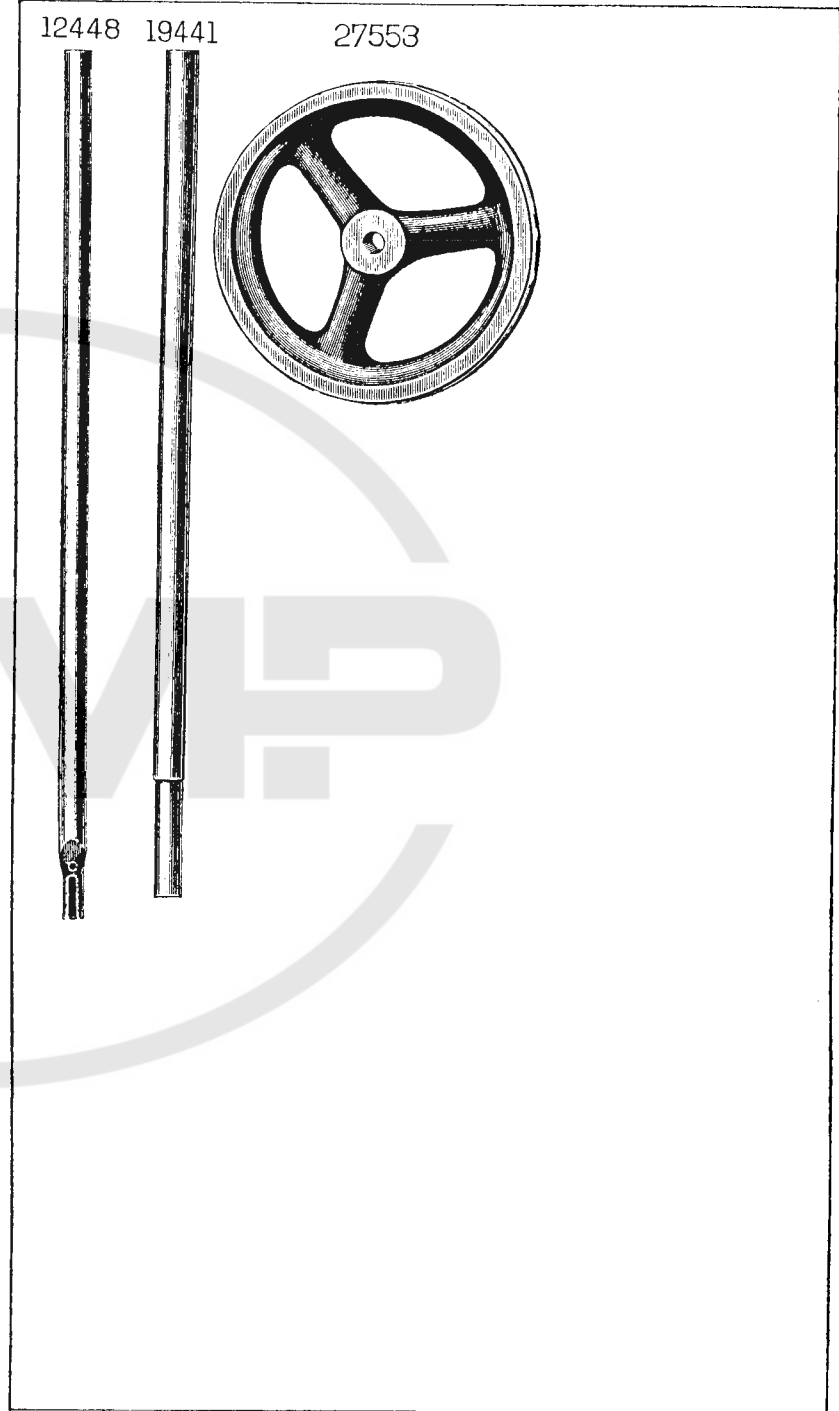
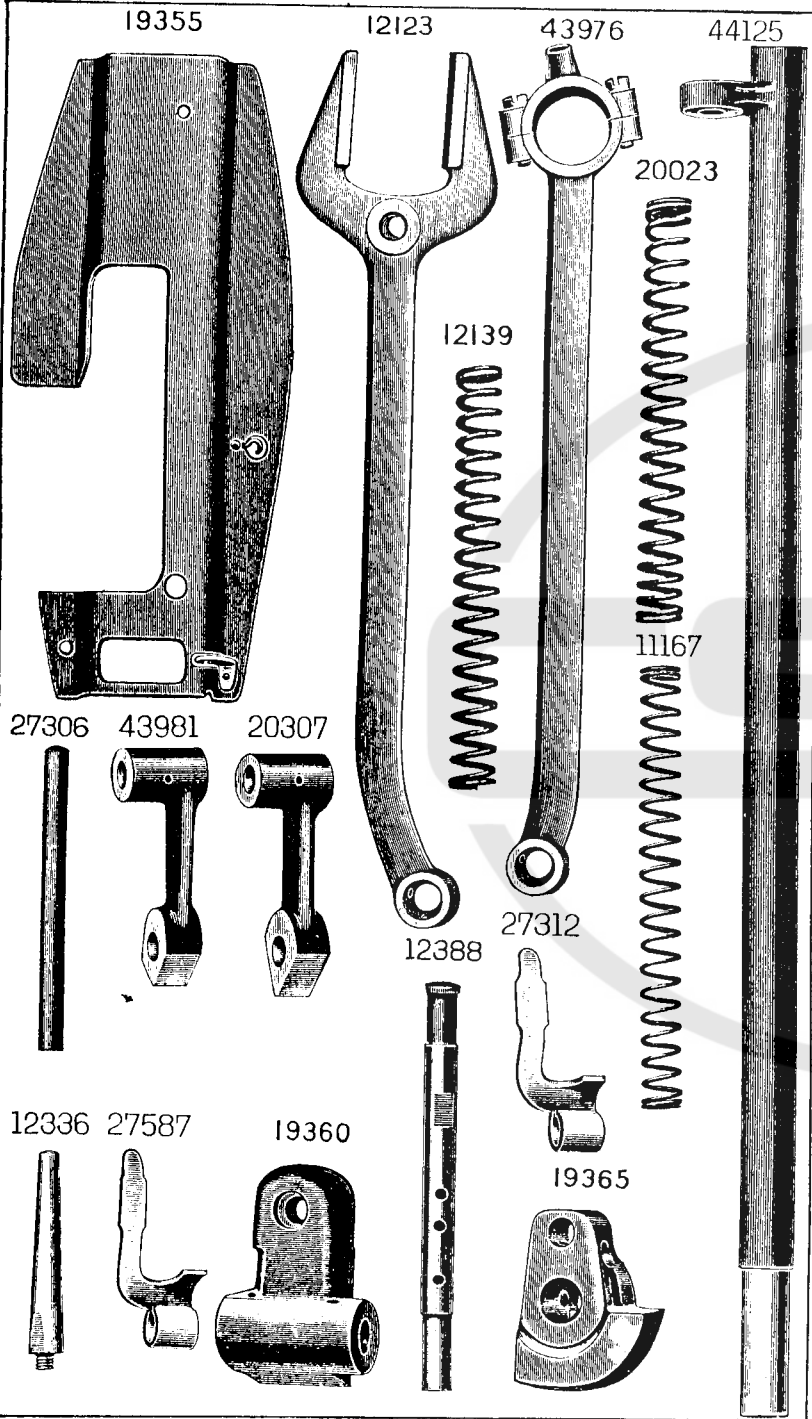

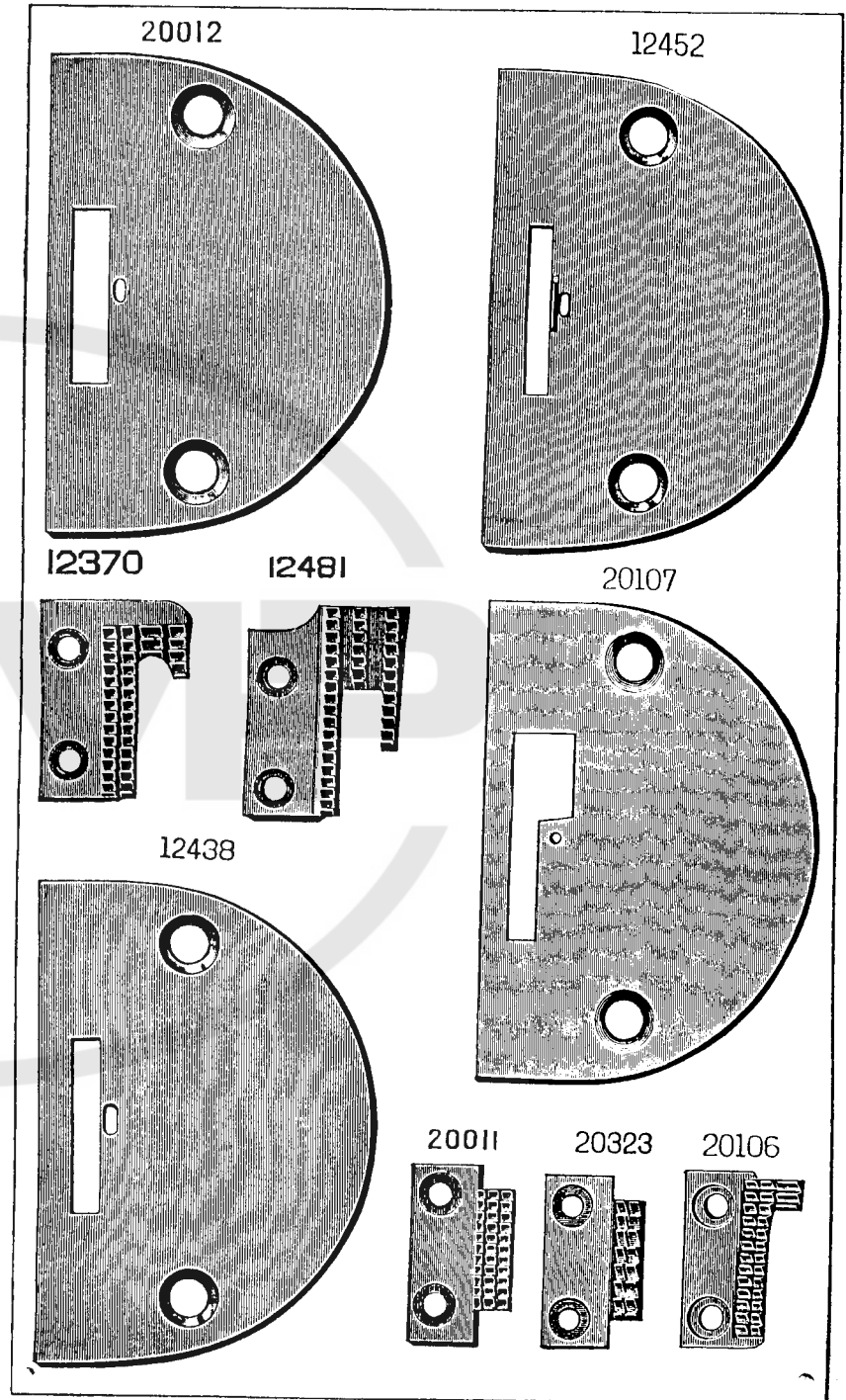
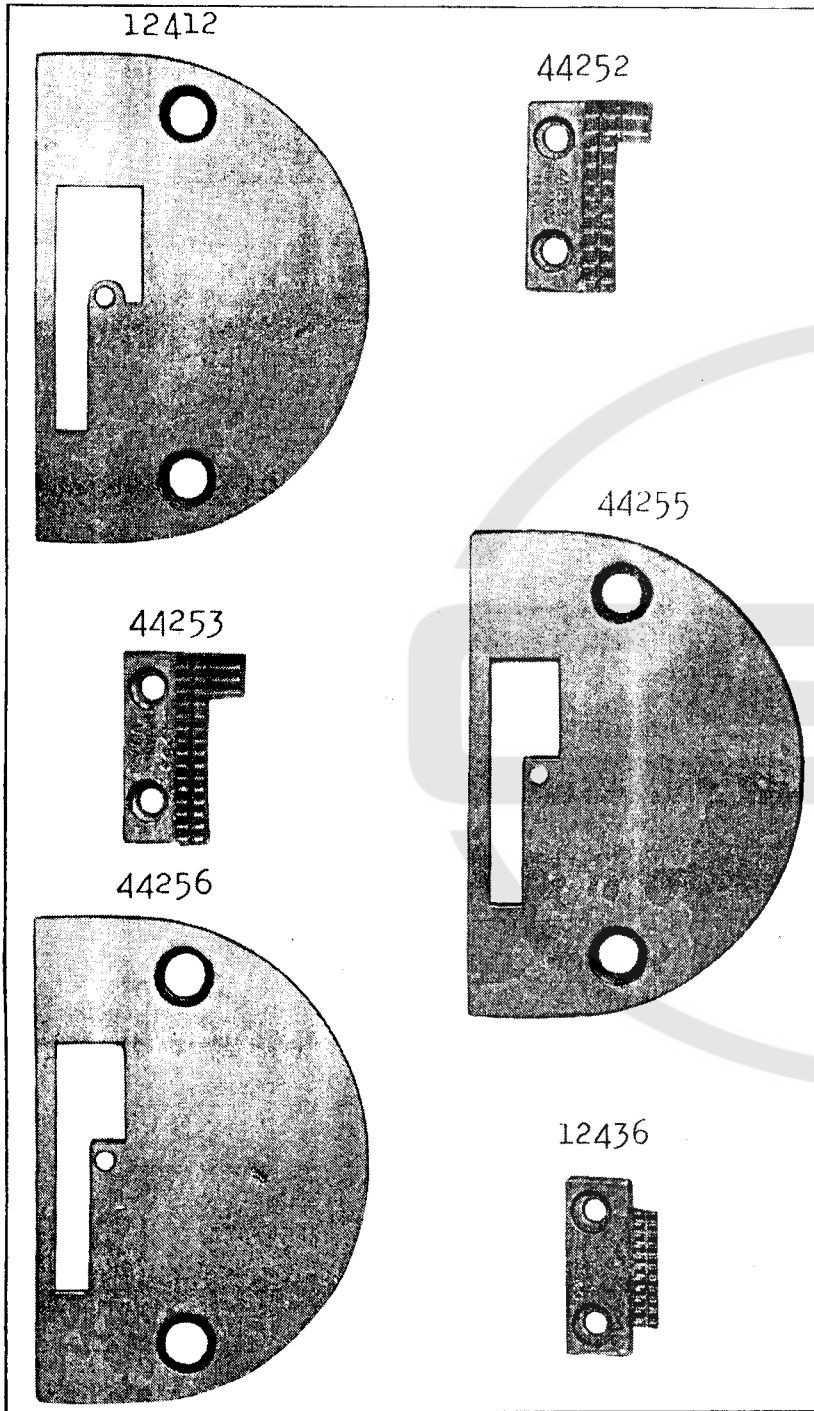

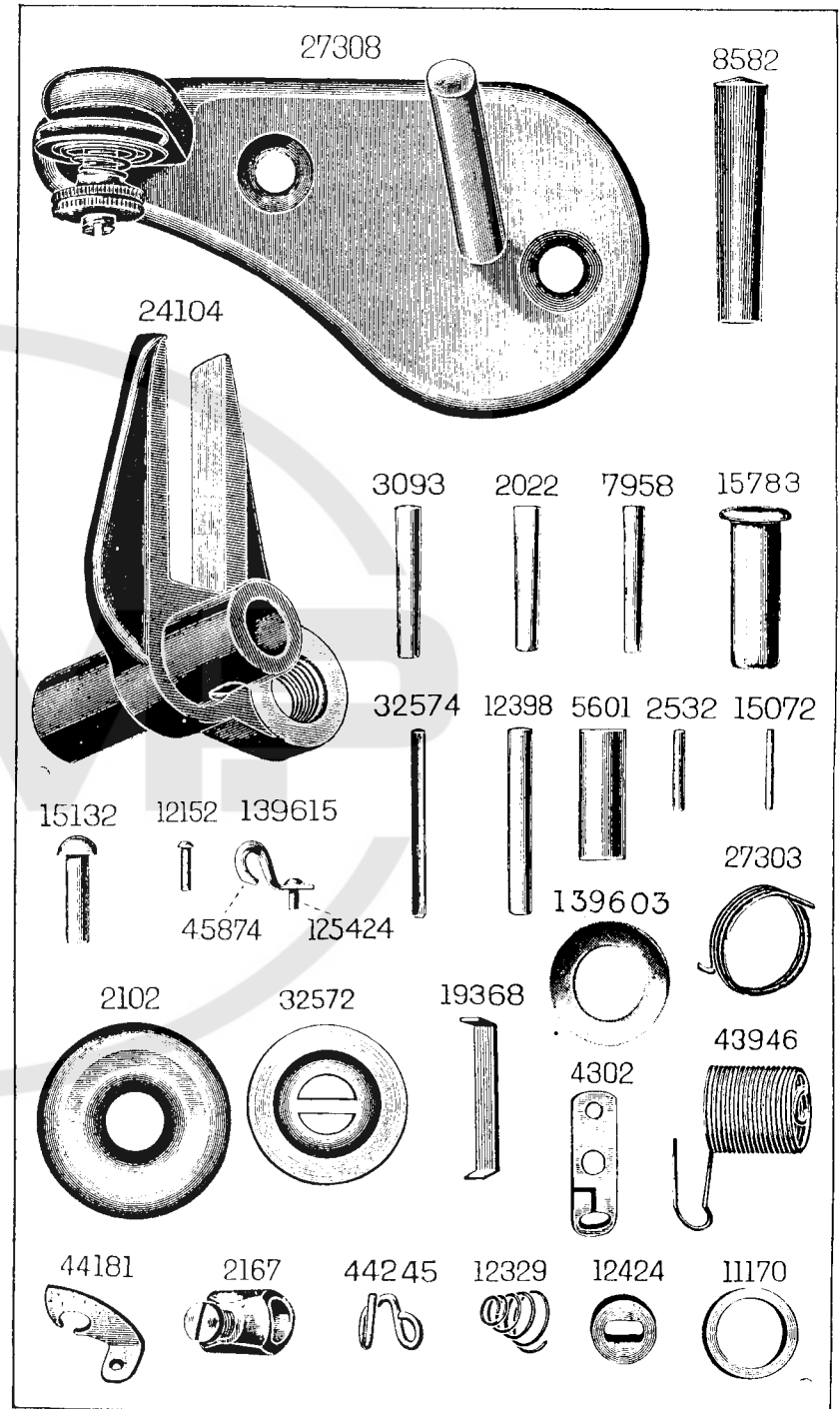
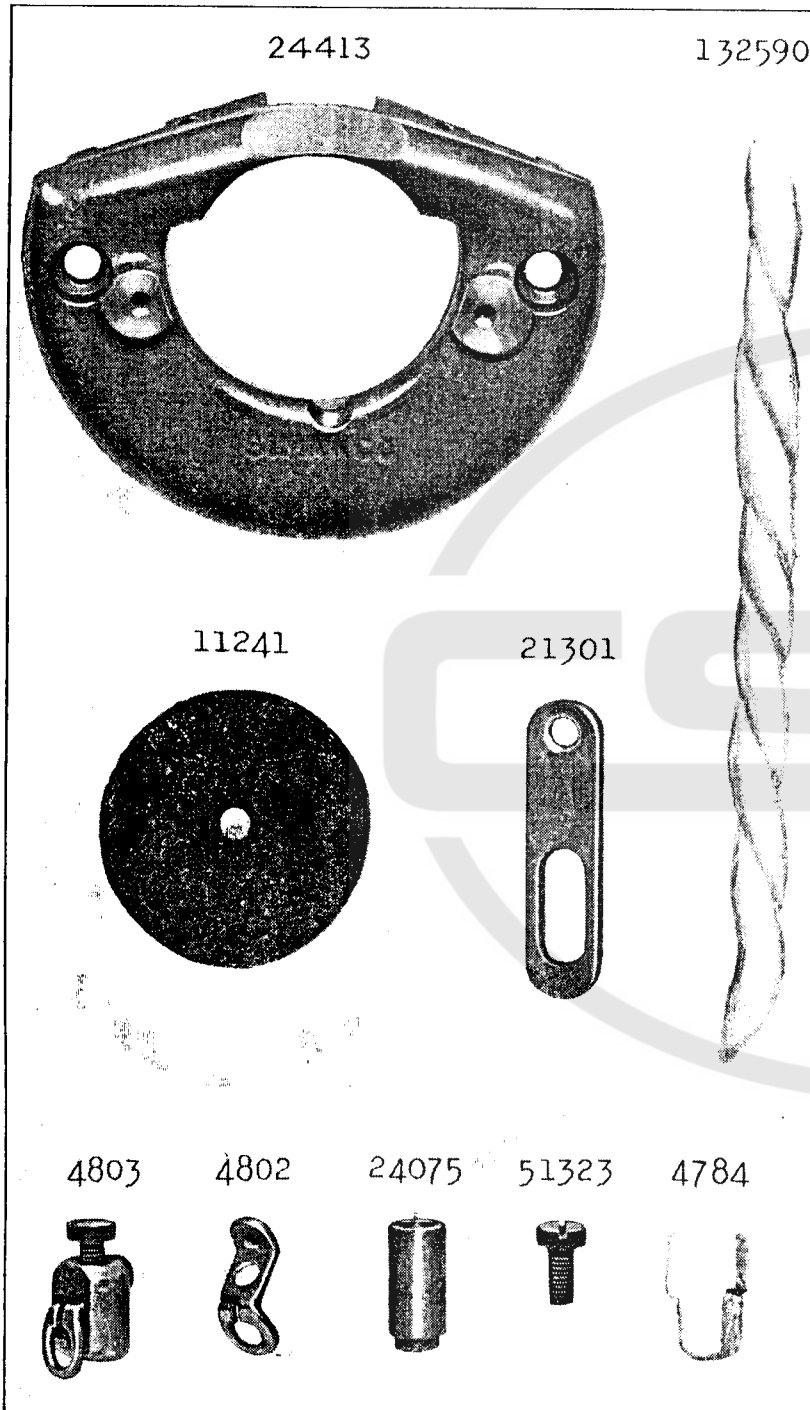

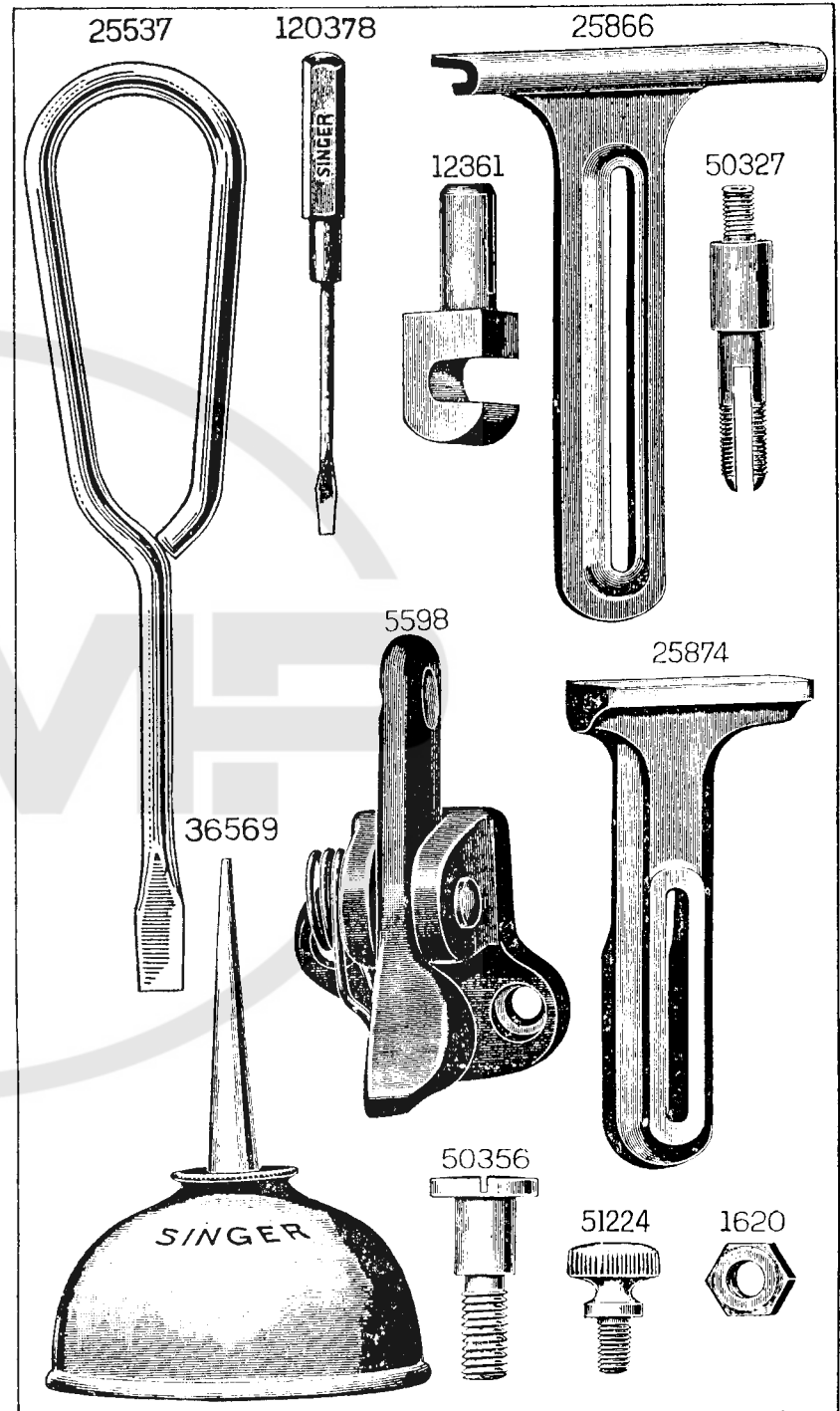
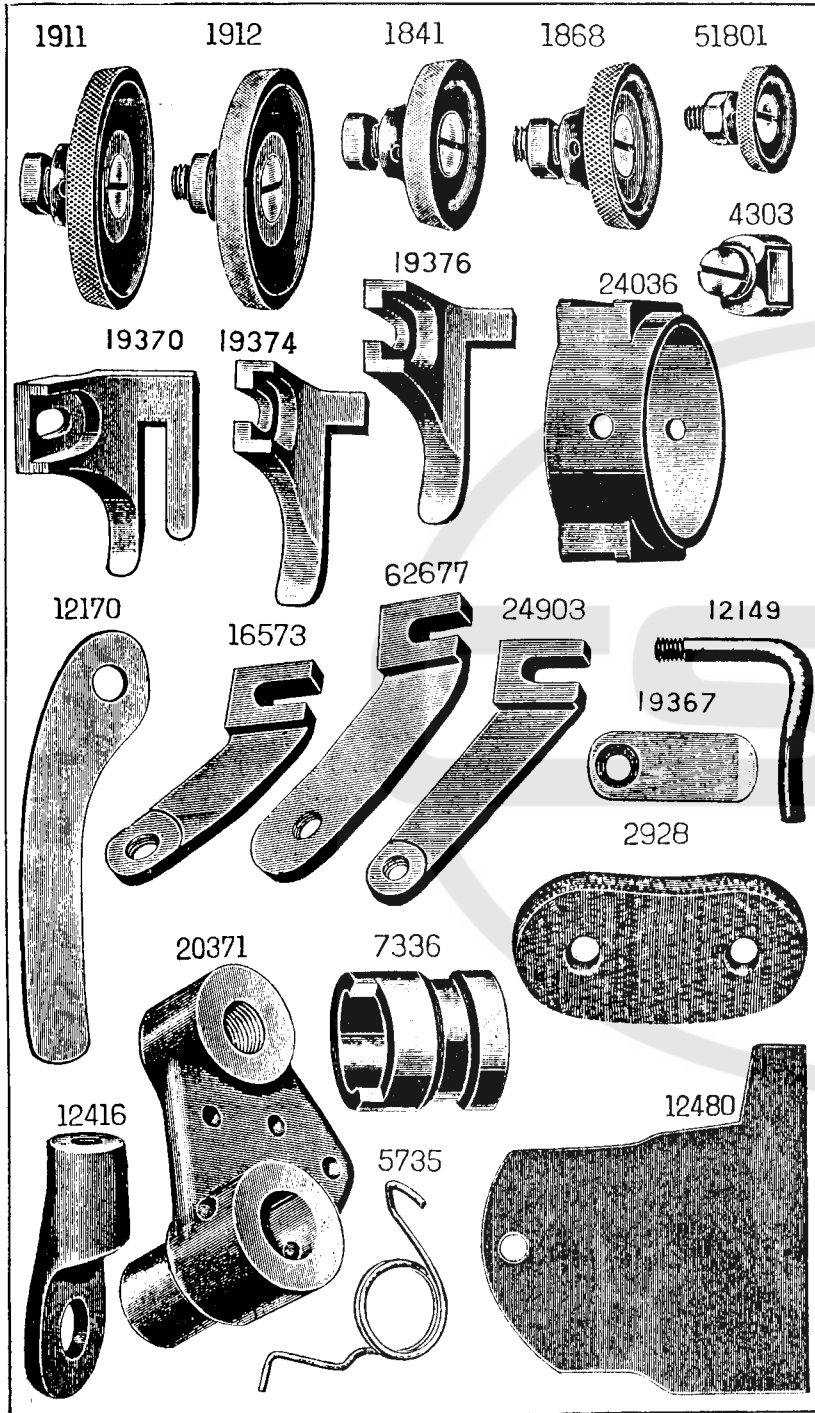

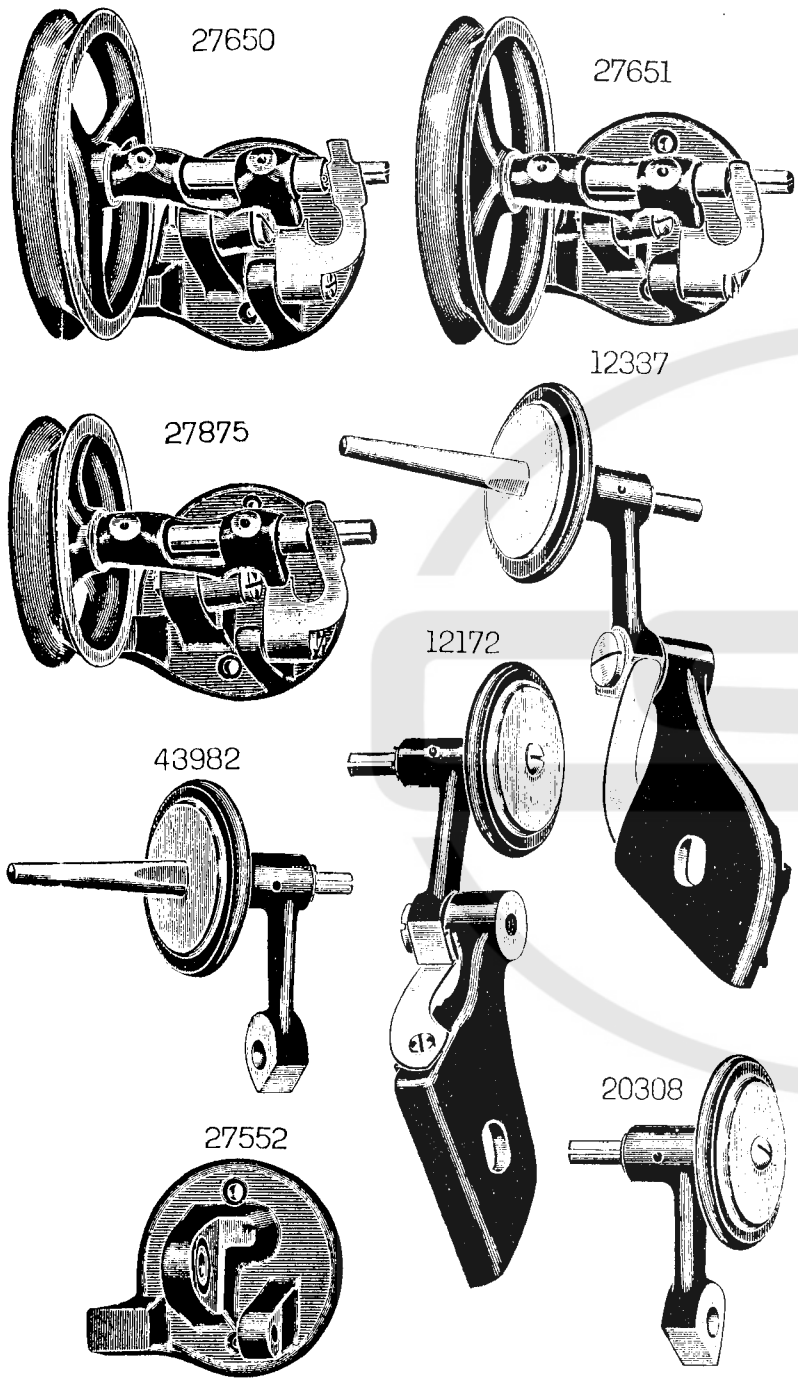

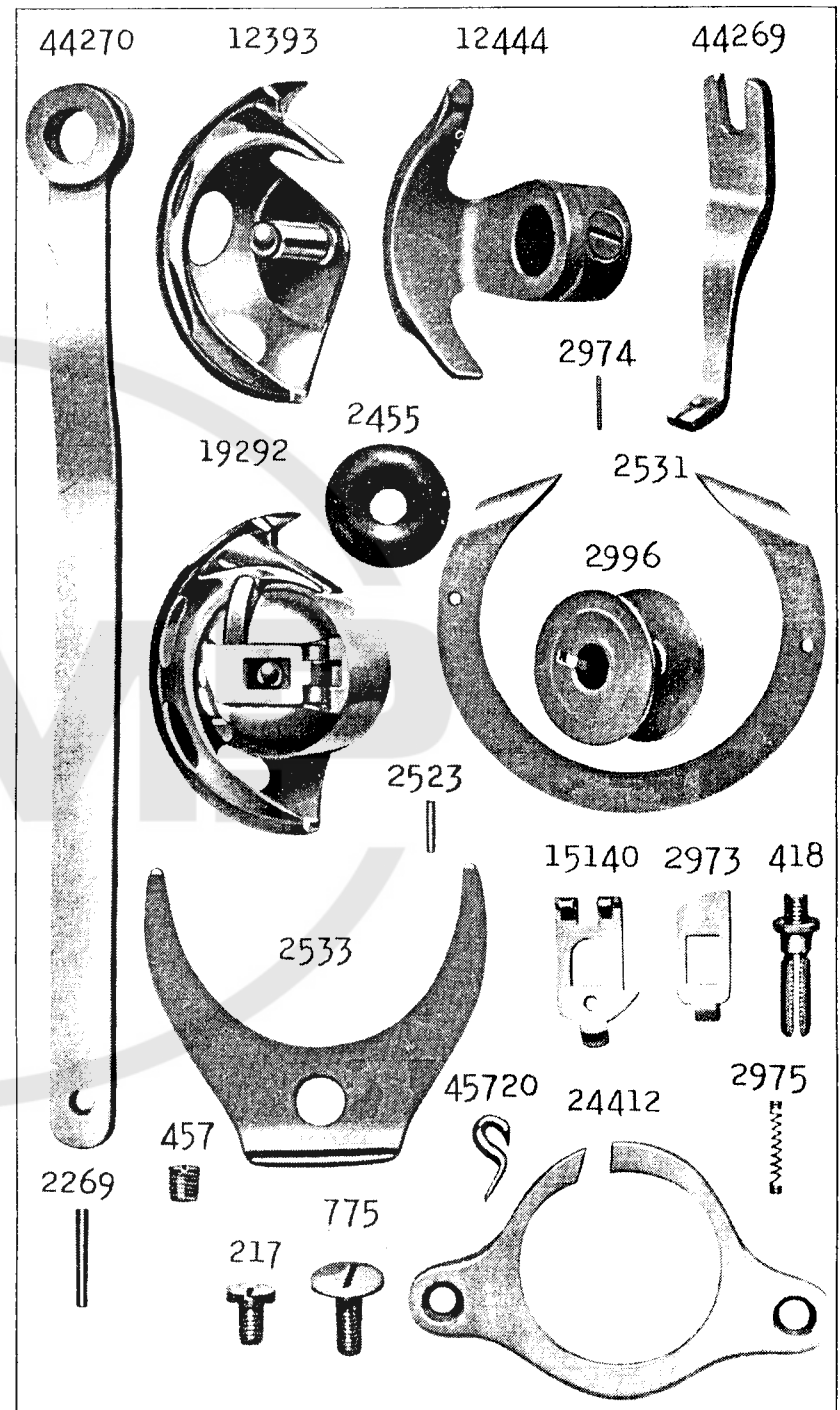
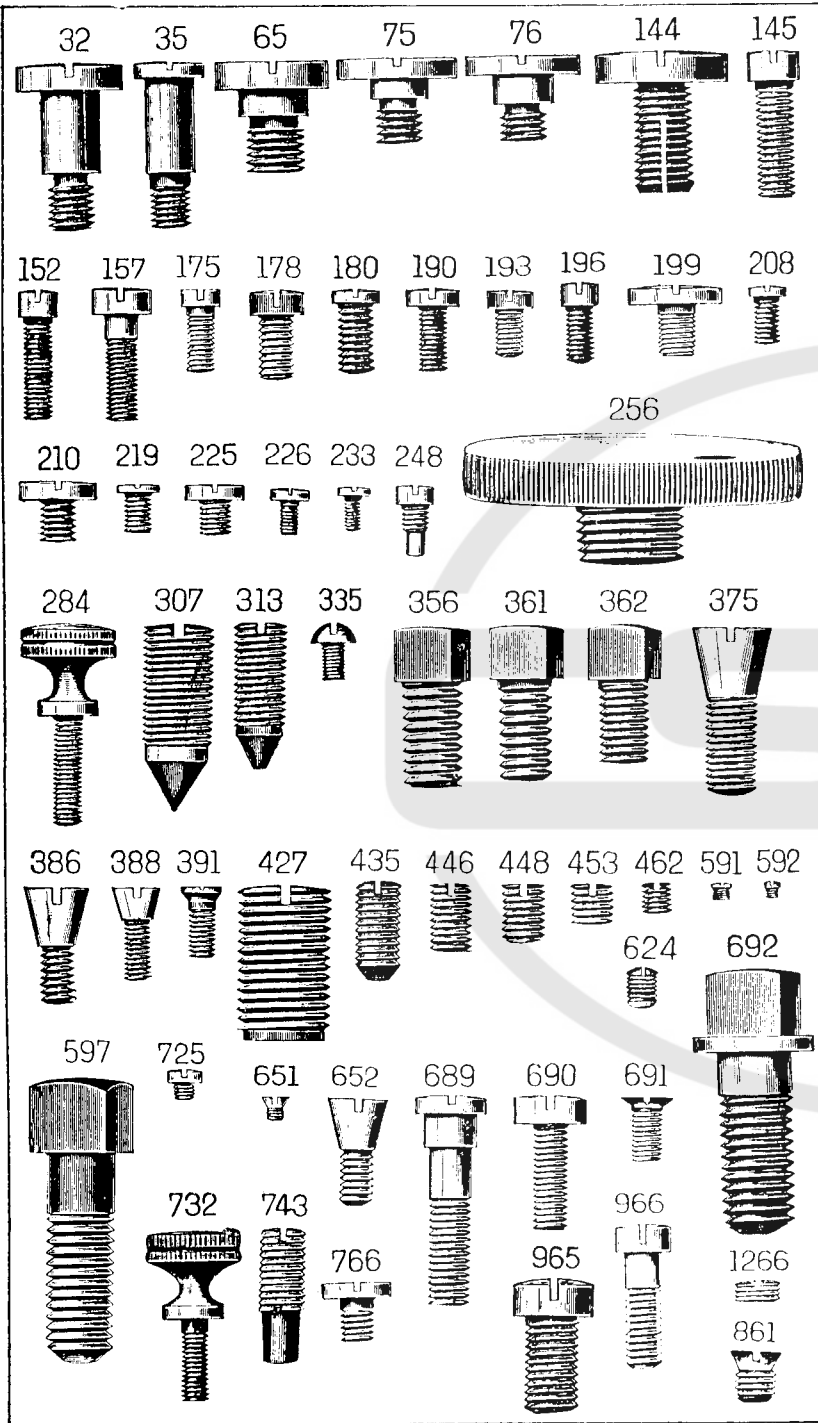

56898

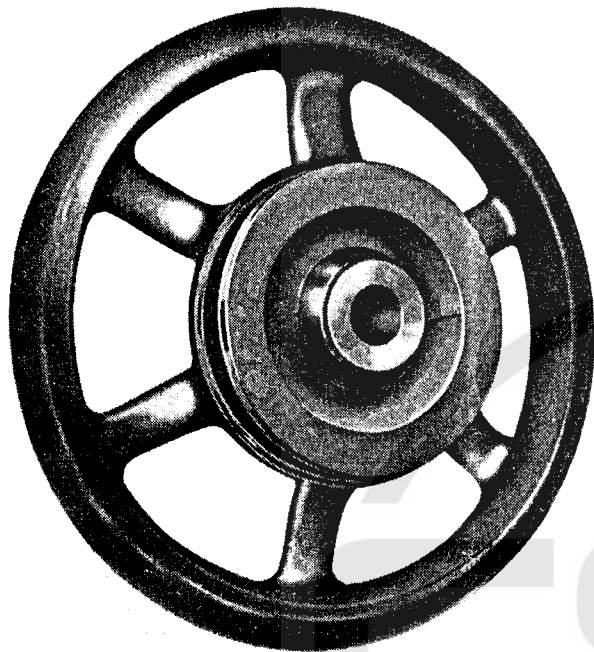

139631

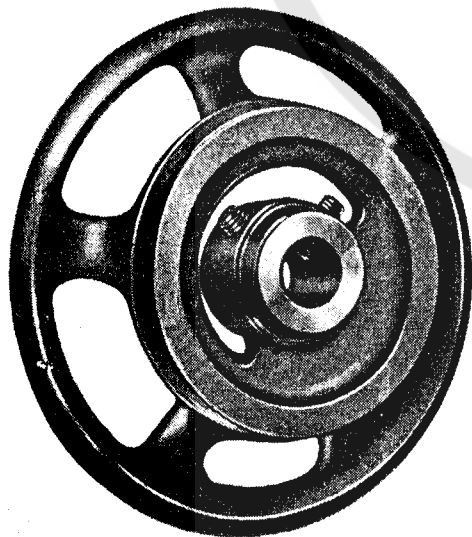

INSTRUCTIONS FOR ORDERING

In ordering from this List, the prefix and affix letters with the part number MUST BE quoted exactly as they are shown in the first column.

A number always indicates the same part in whatever List it may appear, or for whatever machine.

The affix letters (where shown) indicate the style of finish, as follows:—

- A. Hardened, Polished, Nickel Plated and Buffed.
- B. Polished, Nickel Plated and Buffed.
- C. Hardened only.
- D. Polished only.
- E. Soft, Not Polished.
- F. Hardened and Polished.
- G. Bright Rumbled and Nickel Plated.
- H. Blued.
- J. Nickel Plated only.
- K. Hardened and Nickel Plated.
- L. Brass Plated.
- M. Oxidized.
- R. Phosphate Coating Formed on Surface of Iron or Steel.
- S. Cadmium Plated.
- T. Copper Plated.
- U. Zinc Plated.
- V. Silver Plated.
- W. Polished and Nickel Plated.
- X. Black Oxide for Iron and Steel.
- Y. Black Nickel Plated only.
- Z. Chromium Plated.
- A.A. Buffed and Chromium Plated.
- A.B. Hardened, Polished, Buffed and Chromium Plated.
- A.E. Hardened, Bright Rumbled and Nickel Plated.
- A.F. Hardened, Bright Rumbled, Nickel Plated, Bright Rumbled and Chromium Plated.
- A.G. Alumilite (Plain).
- A.H. Alumilite (Dyed). Colour must be stated.
- A.J. Polished, Nickel Plated and Chromium Plated.
- A.K. Hardened, Polished, Nickel Plated and Chromium Plated.
- A.L. Heat Treated for Toughness.
- A.L.D. Heat Treated for Toughness and Polished.
- A.L.X. Heat Treated for Toughness and Black Oxide.
 - A.S. Black Moulded Phenolic.
 - A.T. Beige Moulded Phenolic.
 - A.U. Brown Moulded Phenolic.
- A.W. Hardened then Flame Coated with Tungsten Carbide.
- C.R. Hardened and Phosphate Coating Formed on Surface of Steel.
- F.J. Hardened, Polished and Nickel Plated.
- T.A. Hardened, Polished, Copper and Nickel Plated and Buffed.
- T.B. Copper and Nickel Plated and Polished.
- T.J. Copper and Nickel Plated only.
- T.K. Hardened, Copper and Nickel Plated.
- T.L. Copper and Brass Plated.
- T.M. Copper Plated and Oxidized.
- X.C. Hardened and Black Oxide for Iron and Steel.
- Z.A. Hardened, Polished, Nickel Plated, Buffed and Chromium Plated.
- Z.B. Polished, Nickel Plated, Buffed and Chromium Plated.
- Z.C. Hardened and Chromium Plated.
- Z.D. Polished and Chromium Plated.
- Z.G. Bright Rumbled, Nickel Plated, Bright Rumbled and Chromium Plated.
- Z.J. Nickel and Chromium Plated.
- Z.T. Copper and Chromium Plated.

Parts marked with an asterisk(*) are furnished only when the repairs are made at Factory.

PARTS COMPLETE FOR No. 31K19 MACHINE (OBSOLETE)

DROP FEED.

For Enamelled or Plain Cloth, Light Leather and Fabrics of uneven thickness.

| No. | Plate | | | | |
|--------|-------|---|-----|-----|-----|
| *20339 | — | Arm with 11104, 12453, 12454, 24131 and two 11119 | ... | ... | ... |
| 8582 | 2169 | " Dowel Pin (2) | ... | ... | ... |
| 12453 | 540 | " Oil Tube for Intermediate Bearing | ... | ... | ... |
| 12454 | 540 | " " " with 132590 for Oiling 12409 | ... | ... | ... |
| 15783 | 2169 | " " " (front of arm) | ... | ... | ... |
| 11119 | 540 | " " " (" " ") 15783 with 52045 for Oiling 12408 and 19365 | ... | ... | ... |
| 24131 | 540 | " " " with 52045 for Oiling 20283 | ... | ... | ... |
| 52045 | — | " " " Packing (Cotton Wick) | ... | ... | ... |
| 132590 | 2168 | " " " " (Braided Cotton) for 12454 | ... | ... | ... |
| 748c | 567 | " Screw (back) (2) | ... | ... | ... |
| 854c | 567 | " " (front) (2) | ... | ... | ... |
| 12427 | 535 | Arm Shaft | ... | ... | ... |
| *11104 | 539 | " " Bushing (front) | ... | ... | ... |
| 12357 | 539 | " " Flanged Bushing (back) | ... | ... | ... |
| 448c | 2174 | " " " " (") Set Screw | ... | ... | ... |
| 144c | 2174 | " " Screw | ... | ... | ... |
| 12193 | 544 | " Side Cover | ... | ... | ... |
| 51224d | 2171 | " " " Thumb Screw | ... | ... | ... |
| 12403 | 544 | " Spool Pin and Thread Eyelet (2) | ... | ... | ... |
| 11241 | 2168 | " " " Washer (cloth) | ... | ... | ... |
| *12360 | — | Bed | ... | ... | ... |
| 256w | 2174 | Clamp Stop Motion Clamp Screw | ... | ... | ... |
| 248a | 2174 | " " " " Stop Screw | ... | ... | ... |
| 2020 | 539 | " " " " Washer | ... | ... | ... |
| *3023 | — | " " " Flanged Bushing | ... | ... | ... |
| 4933 | 539 | " " " " 3023 with two 462al | ... | ... | ... |
| 2022 | 2169 | " " " " Pin | ... | ... | ... |
| 462al | 2171 | " " " " Set Screw | ... | ... | ... |

| No. | Plate | |
|--|-------|---|
| 3022j | — | Clamp Stop Motion , complete, Nos. 248a, 256w, 2020 and 4933 |
| 20197 | 535 | Crank Connecting Rod with 20198, 125044 and two 896e ... |
| *20198 | — | " " " " Cap ... |
| 896e | 567 | " " " " Screw ... |
| 908c | 567 | " " " " Hinge Screw ... |
| 1619e | 567 | " " " " " " Nut ... |
| 125044 | — | " " " " Oil Pad (felt) ... |
| 19354 | — | Face Plate ... |
| 44181 | 2169 | " " " " Thread Guard (lower) ... |
| 12150 | — | " " " " (") 44181 with 12152 ... |
| 12152 | 2169 | " " " " (") Rivet ... |
| 45874 | 2169 | " " " " (upper) ... |
| 139615 | 2169 | " " " " (") 45874 with 125424 ... |
| 125424 | 2169 | " " " " (") Rivet ... |
| 19355 | 2164 | Face Plate , complete, Nos. 12150, 19354 and 139615 ... |
| 219d | 2174 | " " " " Screw (2) ... |
| 12368 | 2163 | Feed Bar ... |
| 313c | 2174 | " " " " Screw Centre (2) ... |
| 1519e | 567 | " " " " Nut (2) ... |
| 52165 | 539 | Feed Connecting Link ... |
| 375c | 2174 | " " " " Hinge Screw (2) ... |
| 1518e | 567 | " " " " " " Nut (2) ... |
| 44252 | 2166 | Feed Dog , for Cloth, 12 Teeth (12 Teeth to the inch) ... |
| 20106 | 2167 | " " " " 13 Teeth (16 Teeth to the inch) ... |
| 12370 | 2167 | " " " " 15 Teeth (16 Teeth to the inch) ... |
| 44253 | 2166 | " " " " 16 Teeth (16 Teeth to the inch) ... |
| 43979 | — | " " " " 21 Teeth (22 Teeth to the inch) ... |
| 208a1 | 2174 | " " " " Screw (2) ... |
| <i>NOTE: No. 12370 is sent with this Machine, unless otherwise specified on order.</i> | | |
| 20283 | 539 | Feed and Feed Lifting Eccentric with 446c ... |
| 446c | 2174 | " " " " " " Set Screw ... |
| 24036 | 2170 | " " " " " " Sleeve ... |
| 20284 | 535 | Feed Forked Connection ... |
| 375c | 2174 | " " " " Hinge Screw ... |
| 1518e | 567 | " " " " " " Nut ... |
| 43993 | — | Feed Forked Connection , complete, Nos. 20284, 52165, 56886, two each 375c and 1518e |

| No. | Plate | |
|---------|-------|---|
| 44125 | 2164 | Feed Lifting Rock Shaft ... |
| 12376 | 539 | " " " " Crank with 157c and 1813 ... |
| 157c | 2174 | " " " " " " Clamping Screw ... |
| 1813 | 567 | " " " " " " Roller and Stud ... |
| 44126 | — | Feed Lifting Rock Shaft , complete, Nos. 12376 and 44125 ... |
| 43976 | 2164 | " " " " Crank Connecting Rod with 43977 and two 966e ... |
| *13977 | — | " " " " " " Cap Screw ... |
| 966e | 2174 | " " " " " " " " Screw ... |
| 375c | 2174 | " " " " " " " " Hinge Screw ... |
| 1518e | 567 | Feed Lifting Rock Shaft Crank Connecting Rod Hinge Screw Nut |
| 307c | 2174 | " " " " " " Screw Centre (2) ... |
| 1513j | 567 | " " " " " " " " Nut (2) ... |
| 3039 | 510 | Feed Regulator ... |
| 56886 | — | " " " " 3039 with 818d ... |
| 140139e | 567 | " " " " Hinge Screw ... |
| 139603 | 2169 | " " " " " " Friction Washer ... |
| 818d | 567 | " " " " Thumb Screw ... |
| 12379 | 535 | Feed Rock Shaft ... |
| 29633 | 539 | " " " " Crank with 157c ... |
| 157c | 2174 | " " " " " " Clamping Screw ... |
| 307c | 2174 | " " " " " " Screw Centre (2) ... |
| 1513j | 567 | " " " " " " " " Nut (2) ... |
| 20333 | — | Feed Rock Shaft , complete, Nos. 12379 and 29633 ... |
| 25874 | 2171 | Guide for Raised Throat Plates ... |
| 25866 | 2171 | " " " " Flush Throat Plates ... |
| 284d | 2174 | " " " " Thumb Screw for 25874 ... |
| 732d | 2174 | " " " " " " 25866 ... |
| 12391 | 535 | Lifting Presser Bar (hollow) ... |
| 19356 | 2162 | " " " " Bell Crank ... |
| 199d | 2174 | " " " " " " Cap Screw ... |
| 19357 | 2163 | " " " " " " Connecting Link ... |
| 199d | 2174 | " " " " " " " " Cap Screw ... |
| 19358 | 2162 | " " " " " " Driving Arm ... |
| 19362 | 2163 | " " " " " " " " Eccentric Connection |
| 62637 | — | " " " " " " " " Connection 19362 with 19365 |

| No. | Plate | |
|-------|-------|---|
| 375c | 2174 | Lifting Presser Bar Bell Crank Driving Arm Eccentric Connection Hinge Screw |
| 1518j | 567 | " " " Bell Crank Driving Arm Eccentric Connection Hinge Screw Nut |
| 2049 | 2162 | " " " Bell Crank Driving Arm Pin |
| 19359 | 2163 | " " " " " " " Shaft |
| 19360 | 2164 | " " " " " " " Bracket |
| 19361 | - - | Lifting Presser Bar Bell Crank Driving Arm Shaft Bracket, complete, Nos. 2049 and 19358 to 19360 |
| 965d | 2174 | Lifting Presser Bar Bell Crank Driving Arm Shaft Bracket Screw |
| 24589 | 2162 | " " " Guide Bracket with 453c |
| 453c | 2174 | " " " " " Set Screw |
| 24590 | 2163 | " " " " " Support |
| 175j | 2174 | " " " " " Screw |
| 24716 | - | Lifting Presser Bar Guide Bracket, complete, Nos. 19356, 19357, 19366, 24589 and three 199d |
| 4855 | 2162 | Lifting Presser Bar Lifter |
| 689c | 2174 | " " " " " Screw |
| 1520j | 567 | " " " " " Nut |
| 12327 | 540 | " " " " " Lifting and Releasing Lever Bracket |
| 11167 | 2164 | " " " " " Spring (light) |
| 12139 | 2164 | " " " " " (medium) |
| 20023 | 2164 | " " " " " (heavy) |
| 11170 | 2169 | " " " " " Washer |

NOTE.—No. 11167 is sent with this Machine, unless otherwise specified on order.

| | | |
|-------|------|-----------------------------|
| 19364 | 2163 | Lifting Presser Foot |
| 19375 | 2162 | " " " " " |
| 193j | 2174 | " " " " " Screw |

NOTE.—No. 19364 is sent with this Machine, unless otherwise specified on order.

| | | |
|----------|------|---|
| 139631 | 2619 | Machine Pulley (power) "V" belt groove (diam. of belt groove 2.9") with two 140713al |
| 56898 | 2619 | " " (heavy rim) "V" belt groove (diam. of belt groove 2.9") with two 435al |
| 2862 | 535 | " " (stand) heavy rim, 3" Pulley, for 3022j |
| 2135 | 535 | " " (stand) heavy rim, 2½" Pulley, for 3022j |
| 24297 | 536 | " " Oil Cover for 2135 and 2862 |
| 210d | 2174 | " " " " " Screw |
| 140713al | 567 | " " Set Screw for 139631 |
| 435al | 2174 | " " " " " 56898 |

NOTE.—No. 139631 is sent with this Machine, unless otherwise specified on order.

| No. | Plate | |
|--------|-------|--|
| 12381 | 535 | Needle Bar (hollow) |
| 12382 | 540 | " " Connecting Link with 794c |
| 43997 | - - | " " " " " 12382 with 12384 |
| 794c | 567 | " " " " " Adjusting Screw |
| *12383 | 540 | " " " " " Stud |
| 1904 | 567 | " " " " " Roller (roller only) |
| 453c | 2174 | " " " " " Set Screw |
| 12384 | - - | " " " " " 12383 with 453c and 1904 |
| 19365 | 2164 | " " Crank and Lifting Eccentric with 448c and 743al |
| 743al | 2174 | " " " " " " " Position Screw |
| 448c | 2174 | " " " " " " " Set Screw |
| 93811 | - - | " " Lubricating Wick (2) |
| 936e | 567 | " " Screw Bushing (2) |
| 4302 | 2169 | " " Thread Guard |
| 233d | 2174 | " " " " " Screw |
| 4303 | 2170 | Needle Clamp with 808f |
| 808f | 567 | " " " " " Screw |
| *24104 | 2169 | Oscillating Rock Shaft |
| 12388 | 2164 | " " " " " Hinge Pin |
| 448c | 2174 | " " " " " " " Set Screw |
| 4784 | 2168 | " " " " " Oil Pad |
| 24105 | - - | Oscillating Rock Shaft , complete, Nos. 4784, 12388 and 24104 |
| 139602 | - - | " " " " " 24105 with 908c |
| 12389 | 535 | Oscillating Shaft |
| 19496 | 539 | " " Crank for 19447 |
| 44134 | - - | " " " " " 44135 |
| 3093 | 2169 | " " " " " Pin |
| 457c | 2202 | " " " " " Set Screw for 19447 |
| 453c | 2174 | " " " " " " " 44135 |
| 19448 | 544 | " " " " " Slide Block |
| 226d | 2174 | " " " " " " " Cap Screw |
| 12424 | 2169 | " " " " " " " Washer |
| 988c | 567 | " " " " " " " Screw Stud |
| 1518e | 567 | " " " " " " " Nut |
| 19449 | - - | Oscillating Shaft Crank Slide Block, complete, Nos. 226d, 988c, 12424 and 19448 |
| *19447 | - - | Oscillating Shaft Crank, complete, Nos. 457c, 1518e, 19449 and 19496 |
| 44135 | - - | Oscillating Shaft Crank, complete, Nos. 1518e, 19449, 44134 and two 453c |
| 688j | 567 | Pressure Regulating Thumb Screw |

| No. | Plate | | | | | |
|--------|-------|--|-----|-----|-----|-----|
| 2996 | 2202 | Shuttle Bobbin | ... | ... | ... | ... |
| 15140 | 2202 | " " Case Latch | ... | ... | ... | ... |
| 2973 | 2202 | " " " " Lever | ... | ... | ... | ... |
| 2974 | 2202 | " " " " Fulcrum Pin | ... | ... | ... | ... |
| 2975 | 2202 | " " " " Spring | ... | ... | ... | ... |
| 592c | 2174 | " " " " Stop Screw | ... | ... | ... | ... |
| 15141 | — | " " " Hinge, Nos. 2973, 2974 and 15140 | ... | ... | ... | ... |
| 24412 | 2202 | " " " Position Plate | ... | ... | ... | ... |
| 391j | 2174 | " " " " " Screw | ... | ... | ... | ... |
| 62740 | 2162 | " " " with 591f, 592c, 2975, 15141 and 15278 | ... | ... | ... | ... |
| 12393 | 2202 | Shuttle Body | ... | ... | ... | ... |
| 591f | 2174 | " Tension Regulating Screw... | ... | ... | ... | ... |
| 15278 | 2162 | " " Spring | ... | ... | ... | ... |
| 19292 | 2202 | Shuttle, 1 1/8" diam., complete, Nos. 2996, 12393 and 62740 | ... | ... | ... | ... |
| *12394 | — | Shuttle Driver | ... | ... | ... | ... |
| 12444 | 2202 | " " 12394 with two 1266c | ... | ... | ... | ... |
| 2049 | 2162 | " " Pin | ... | ... | ... | ... |
| 1266c | 2174 | " " Set Screw | ... | ... | ... | ... |
| 2531 | 2202 | Shuttle Race Back | ... | ... | ... | ... |
| 2532 | 2169 | " " " Position Pin | ... | ... | ... | ... |
| 2533 | 2202 | " " " Spring | ... | ... | ... | ... |
| 907d | 567 | " " " " Screw | ... | ... | ... | ... |
| 24413 | 2168 | " " Body | ... | ... | ... | ... |
| 62502 | — | " " " 24413 with 24418 and two 1053d | ... | ... | ... | ... |
| 24418 | 2162 | " " Cap | ... | ... | ... | ... |
| 1053d | 567 | Shuttle Race Cap Screw | ... | ... | ... | ... |
| 24419 | — | Shuttle Race, complete, Nos. 907d, 2531, 2533, 24412, 62502, two each 391j and 2532 | ... | ... | ... | ... |
| 145d | 2174 | Shuttle Race Screw (2) | ... | ... | ... | ... |
| 12431 | — | Shuttle Race Slide | ... | ... | ... | ... |
| 4307 | 544 | " " " Spring | ... | ... | ... | ... |
| 725c | 2174 | " " " " Screw | ... | ... | ... | ... |
| 12432 | 544 | Shuttle Race Slide, complete, Nos. 4307, 12431 and two 725c | ... | ... | ... | ... |
| 20060 | 544 | Slack Thread Regulator | ... | ... | ... | ... |
| 225f | 2174 | " " " Adjusting Screw | ... | ... | ... | ... |
| 2102 | 2169 | Tension Disc | ... | ... | ... | ... |
| 1560c | 567 | " Regulating Thumb Nut | ... | ... | ... | ... |
| 32572 | 2169 | " Releasing Disc | ... | ... | ... | ... |

| No. | Plate | | | | | |
|--|-------|---|-----|-----|-----|-----|
| 43944 | 2162 | Tension Releasing Lever... | ... | ... | ... | ... |
| 12398 | 2169 | " " " Hinge Pin | ... | ... | ... | ... |
| 12329 | 2169 | " " " Spring | ... | ... | ... | ... |
| 32574 | 2169 | " " " Pin | ... | ... | ... | ... |
| *50327c | 2171 | " Screw Stud | ... | ... | ... | ... |
| 44141 | — | " " " 50327c with 1560c | ... | ... | ... | ... |
| 43945 | 2162 | " Spring | ... | ... | ... | ... |
| 12149 | 2170 | " Thread Guard | ... | ... | ... | ... |
| 44118 | — | Tension, complete, Nos. 7336, 32572, 32574, 43945, 43946, 44141 and two 2102 | ... | ... | ... | ... |
| 52454 | 2162 | Thread Retainer | ... | ... | ... | ... |
| 624 | 2174 | " " Set Screw | ... | ... | ... | ... |
| 12404 | 540 | Thread Take-up Crank | ... | ... | ... | ... |
| 3094 | 514 | " " " Wedge | ... | ... | ... | ... |
| 690c | 2174 | " " " " Screw | ... | ... | ... | ... |
| 12408 | 540 | Thread Take-up Lever | ... | ... | ... | ... |
| 775e | 2202 | " " " Cap Screw | ... | ... | ... | ... |
| 12166 | 544 | " " " Hinge Pin | ... | ... | ... | ... |
| 12409 | 540 | " " " Link | ... | ... | ... | ... |
| 11204 | 540 | " " " " Hinge Pin | ... | ... | ... | ... |
| 435c | 2174 | " " " " " " Set Screw | ... | ... | ... | ... |
| 12410 | — | Thread Take-up Lever, complete, Nos. 12166, 12408 and 12409 | ... | ... | ... | ... |
| 43946 | 2169 | Thread Take-up Spring | ... | ... | ... | ... |
| 7336 | 2170 | " " " Regulator | ... | ... | ... | ... |
| 448c | 2174 | " " " " Set Screw | ... | ... | ... | ... |
| 43990 | — | Thread Take-up, complete, Nos. 775e, 11204, 12404, 12410 and 43997 | ... | ... | ... | ... |
| 12412 | 2166 | Throat Plate (large needle hole) for 12370 and 43979 | ... | ... | ... | ... |
| 20107 | 2167 | " " (small " ") " 20106 | ... | ... | ... | ... |
| 20315 | — | " " (large " ") " 20106 | ... | ... | ... | ... |
| 44255 | 2166 | " " (small " ") " 44252 and 44253 | ... | ... | ... | ... |
| 44256 | 2166 | " " (large " ") " 44252 and 44253 | ... | ... | ... | ... |
| 691f | 2174 | " " " Screw (2) | ... | ... | ... | ... |
| <i>NOTE.—No. 12412 is sent with this Machine, unless otherwise specified on order.</i> | | | | | | |
| 19366 | 2163 | Vibrating Presser Bar | ... | ... | ... | ... |
| 19367 | 2170 | " " " Cap | ... | ... | ... | ... |
| 199d | 2174 | " " " " Screw for 19366 | ... | ... | ... | ... |
| 219d | 2174 | " " " " " 19367 | ... | ... | ... | ... |
| 19368 | 2169 | " " " Cushion (rawhide) | ... | ... | ... | ... |
| 19369 | 2162 | " " " Spring | ... | ... | ... | ... |
| 335d | 2174 | " " " " Screw | ... | ... | ... | ... |

| No. | Plate | | | | | | |
|-------|-------|--------------------------|--------------------------|-----|-----|-----|-----|
| 19370 | 2170 | Vibrating Presser | Foot for 12370 and 43979 | ... | ... | ... | ... |
| 19374 | 2170 | " | " " " 12457 | ... | ... | ... | ... |
| 19376 | 2170 | " | " " " 20106 | ... | ... | ... | ... |
| 217d | 2202 | " | " " Screw | ... | ... | ... | ... |

NOTE. —No. 19370 is sent with this Machine, unless otherwise specified on order.

| | | | | | | | |
|--------|--|-----------------|--|-----|-----|-----|--------|
| 139622 | | Drip Pan | with four $\frac{3}{4}$ " wire nails | ... | ... | ... | ... |
| 80864 | | " | " " " " Wood Screws $\frac{1}{4}$ " No. 5, for machines with | ... | ... | ... | S.D.A. |

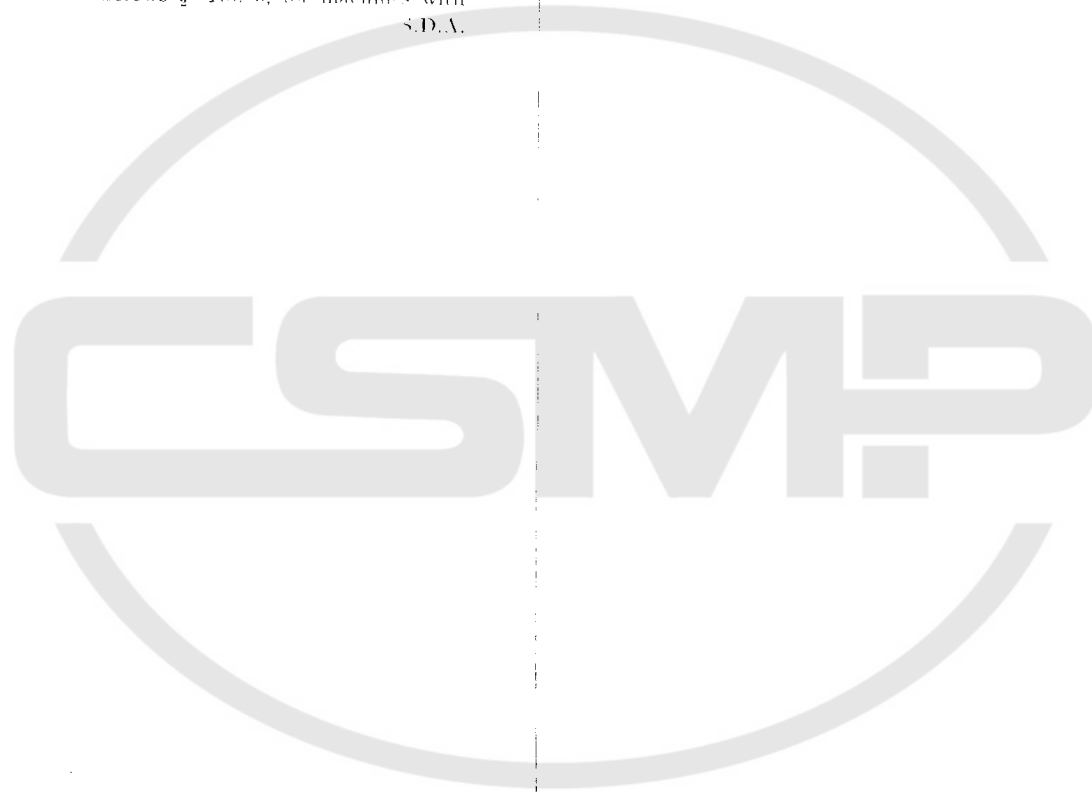

PARTS COMPLETE
FOR
Nos. 31K21 MACHINE
(OBSOLETE)

DROP FEED. ROLLER PRESSER.
FOR LEATHER WORK.

| No. | Plate | |
|--------|-------|---|
| *12355 | — | Arm with 11104, 11119, 12453, 12454 and 24131 |
| 8582 | 2169 | " Dowel Pin (2) |
| 12453 | 540 | " Oil Tube for Intermediate Bearing |
| 12454 | 540 | " " " with 132590 for Oiling 12409 |
| 15783 | 2169 | " " " (front of arm) |
| 11119 | 540 | " " " (" " ") 15783 with 52045 for Oiling 12408 and 19365 |
| 24131 | 540 | " " " with 52045 for Oiling 20283 |
| 52045 | — | " " " Packing (Cotton Wick) |
| 132590 | 2168 | " " " " (Braided Cotton) for 12454 |
| 748c | 567 | " Screw (back) (2) |
| 854c | 567 | " " (front) (2) |
| 12427 | 535 | Arm Shaft |
| *11104 | 539 | " " Bushing (front) |
| 12357 | 539 | " " Flanged Bushing (back) |
| 448c | 2174 | " " " " (" ") Set Screw |
| 144c | 2174 | " " Screw |
| 12480 | 2170 | " Side Cap |
| 219f | 2174 | " " " Screw |
| 12193 | 544 | " " Cover |
| 51224d | 2171 | " " " Thumb Screw |
| 12403 | 544 | " Spool Pin and Thread Eyelet (2) |
| 11241 | 2168 | " " " Washer (Cloth) |
| *12360 | — | Bed |
| 256w | 2174 | Clamp Stop Motion Clamp Screw |
| 248a | 2174 | " " " " Stop Screw |
| 2020 | 539 | " " " " Washer |
| *3023 | — | " " " " Flanged Bushing |
| 4933 | 539 | " " " " " 3023 with two 462al |
| 2022 | 2169 | " " " " " Pin |
| 462al | 2174 | " " " " " Set Screw |
| 3022j | — | Clamp Stop Motion, complete, Nos. 248a, 256w, 2020 and 4933 |

| No. | Plate | |
|---|-------|---|
| 20197 | 535 | Crank Connecting Rod with 20198, 125044 and two 896c |
| *20198 | — | " " " " Cap |
| 896c | 567 | " " " " " Screw |
| 908c | 567 | " " " " " Hinge Screw |
| 1619c | 567 | " " " " " Nut |
| 125044 | — | " " " " " Oil Pad (felt) |
| 20057 | 535 | Face Plate |
| 44181 | 2169 | " " Thread Guard (lower) |
| 12150 | — | " " " " " (" ") 44181 with 12152 |
| 12152 | 2169 | " " " " " (" ") Rivet |
| 45874 | 2169 | " " " " " (upper) |
| 139615 | 2169 | " " " " " (" ") 45874 with 125424 |
| 125424 | 2169 | " " " " " (" ") Rivet |
| 20058 | — | Face Plate, complete, Nos. 12150, 20057 and 139615 |
| 190d | 2174 | " " Screw |
| 51224d | 2171 | " " Thumb Screw |
| 12368 | 2163 | Feed Bar |
| 313c | 2174 | " " Screw Centre (2) |
| 1519c | 567 | " " " " " Nut (2) |
| 12197 | 539 | Feed Cam and Feed Lifting Eccentric with 446c |
| 446c | 2174 | " " " " " " " " Set Screw |
| 52165 | 539 | Feed Connecting Link |
| 375c | 2174 | " " " " " Hinge Screw (2) |
| 1518c | 567 | " " " " " " " " Nut (2) |
| 12436 | 2166 | Feed Dog, for Leather, 11 Teeth (18 Teeth to the inch) |
| 20011 | 2167 | " " " " " " " " " " " |
| 20323 | 2167 | " " 8 Teeth (12 Teeth to the inch) |
| 208al | 2174 | " " Screw (2) |
| NOTE. No. 12136 is sent with this Machine, unless otherwise specified on order. | | |
| 12123 | 2164 | Feed Forked Connection |
| 375c | 2174 | " " " " " Hinge Screw |
| 1518c | 567 | " " " " " " " " Nut |
| 43994 | — | Feed Forked Connection, complete, Nos. 12123, 52165, 56886, two each 375c and 1518c |
| 12374 | 535 | Feed Lifting Rock Shaft |
| 12376 | 539 | " " " " " Crank (front) with 157c and 1813 |
| 157c | 2174 | " " " " " " (" ") Clamping Screw |
| 1813 | 567 | " " " " " " (" ") Roller and Stud |
| 14656 | 539 | " " " " " " (back) with 462al |

| No. | Plate | |
|----------|-------|--|
| 2049 | 2162 | Feed Lifting Rock Shaft Crank (back) Pin |
| 462al | 2174 | " " " " " (") Set Screw |
| 20001 | — | Feed Lifting Rock Shaft, complete, Nos. 12374, 12376 and 16556 |
| 43976 | 2164 | Feed Lifting Rock Shaft Crank Connecting Rod with 43977 and two 966e |
| *43977 | — | " " " " " " " " Cap |
| 966e | 2174 | " " " " " " " " Screw |
| 375c | 2174 | " " " " " " " " Hinge Screw |
| 1518e | 567 | " " " " " " " " Screw Nut |
| 307c | 2174 | " " " " " " " " Screw Centre (2) |
| 1513j | 567 | " " " " " " " " Nut (2) |
| 3039 | 540 | Feed Regulator |
| 56886 | — | " " " 3039 with 818d |
| 140139e | 567 | " " " Hinge Screw |
| 139603 | 2169 | " " " " " Friction Washer |
| 818d | 567 | " " " Thumb Screw |
| 12379 | 535 | Feed Rock Shaft |
| 29633 | 539 | " " " Crank with 157c |
| 157c | 2174 | " " " " Clamping Screw |
| 307c | 2174 | " " " " Screw Centre (2) |
| 1513j | 567 | " " " " " Nut (2) |
| 20333 | — | Feed Rock Shaft, complete, Nos. 12379 and 29633 |
| 25874 | 2171 | Guide for Raised Throat Plates |
| 25866 | 2171 | " " " Flush Throat Plates |
| 284d | 2174 | " " " Thumb Screw for 25874 |
| 732d | 2174 | " " " " " 25866 |
| 139631 | 2619 | Machine Pulley, (power) "V" belt groove (diam. of belt groove 2.9") with two 140713al |
| 56898 | 2619 | " " " (heavy rim) "V" belt groove (diam. of belt groove 2.9") with two 435al |
| 85200 | 535 | " " " (stand) heavy rim, 2½" Pulley, with two 448c |
| 2862 | 535 | " " " (stand) heavy rim, 3" Pulley for 3022j |
| 2135 | 535 | " " " (stand) heavy rim, 2½" Pulley for 3022j |
| 24297 | 536 | " " " Off Cover for 2135 and 2862 |
| 210d | 2174 | " " " " " Screw |
| 448c | 2174 | " " " Set Screw for 85200 |
| 140713al | 567 | " " " " " " 139631 |
| 435al | 2174 | " " " " " " 56898 |

NOTE. —No. 139631 is sent with this Machine, unless otherwise specified on order.

| No. | Plate | |
|--------|-------|---|
| 12448 | 2165 | Needle Bar (hollow) |
| 12382 | 540 | " " " Connecting Link with 794e |
| 43997 | — | " " " " " 12382 with 12384 |
| 794e | 567 | " " " " " Adjusting Screw |
| *12383 | 540 | " " " " " Stud |
| 1904 | 567 | " " " " " Roller (roller only) |
| 453c | 2174 | " " " " " Set Screw |
| 12384 | — | " " " " " 12383 with 453c and 1904 |
| 20188 | 540 | Needle Bar Crank with 1065al |
| 1065al | 567 | " " " " " Position Screw |
| 93811 | — | " " " Lubricating Wick (2) |
| 936e | 567 | " " " Screw Bushing |
| 44245 | 2169 | " " " Thread Guard |
| 233d | 2174 | " " " " " Screw |
| 2167 | 2169 | Needle Clamp with 196al |
| 196al | 2174 | " " " Screw |
| 44004 | — | Oil Cup |
| 44214 | — | " " " Extension |
| 44005 | — | " " " " 44214 with 24075 |
| 24075 | 2168 | " " " " Post |
| 44006 | — | " " " Packing (Felt) |
| 44007 | 2162 | Oil Cup, complete, Nos. 44004 to 44006 |
| *24104 | 2169 | Oscillating Rock Shaft |
| 12388 | 2164 | " " " " " Hinge Pin |
| 448c | 2174 | " " " " " " Set Screw |
| 4784 | 2168 | " " " " " Oil Pad |
| 24105 | — | Oscillating Rock Shaft, complete, Nos. 4784, 12388 and 24104 |
| 139602 | — | " " " " " 24105 with 908c |
| 12389 | 535 | Oscillating Shaft |
| 19496 | 539 | " " " Crank for 19447 |
| 41134 | — | " " " " " 44135 |
| 3093 | 2169 | " " " " " Pin |
| 457c | 2202 | " " " " " Set Screw for 19447 |
| 453c | 2174 | " " " " " " 44135 |
| 19448 | 544 | " " " " " Slide Block |
| 226d | 2174 | " " " " " Cap Screw |
| 12424 | 2169 | " " " " " " " Washer |
| 988c | 567 | " " " " " " " Screw Stud |
| 1518e | 567 | " " " " " " " Nut |
| 19449 | — | Oscillating Shaft Crank Slide Block, complete, Nos. 226d, 988c, 12424 and 19448 |

16x6 - Needle, size 16...

| No. | Plate | |
|---|-------|--|
| *19447 | --- | Oscillating Shaft Crank , complete, Nos. 457c, 1518c, 19449 and 19496 |
| 44135 | --- | Oscillating Shaft Crank , complete, Nos. 1518c, 19449, 44134 and two 453c |
| 19441 | 2165 | Presser Bar (hollow) |
| 20059 | 540 | Presser Bar Guide Bracket with 453c |
| 453c | 2174 | " " " " Set Screw |
| 2062 | 544 | " " Lifter |
| 689c | 2174 | " " " Screw |
| 1520r | 567 | " " " Nut |
| 12327 | 540 | " " Lifting and Releasing Lever Bracket |
| 11167 | 2164 | " " Spring (light) |
| 11170 | 2169 | " " " Washer |
| 19464 | --- | Presser Bar , complete, Nos. 190d, 19441 to 19443 and 20445 |
| 19165 | 547 | Presser Foot |
| 20114 | 547 | " " " |
| 20271 | 547 | " " for Beading and Top Stitching |
| 20272 | 547 | " " " Shoe Tips and Gores |
| 20273 | 547 | " " " Inside Stays |
| 20274 | 547 | " " " Outside Stays |
| <i>NOTE: Presser Feet are only supplied with this Machine when specified on order and at an extra charge.</i> | | |
| 190d | 2174 | Presser Foot Screw |
| 688j | 567 | Pressure Regulating Thumb Screw |
| 51801 | 2170 | Roller , $\frac{9}{16}$ " diam., coarse, with 388d and 1550j |
| 51802 | --- | " $\frac{9}{16}$ " " fine, " 388d " 1550j |
| 1868 | 2170 | " $\frac{7}{8}$ " " coarse, with 652d " 1528j |
| 1841 | 2170 | " $\frac{7}{8}$ " " fine, " 652d " 1528j |
| 1911 | 2170 | " $1\frac{1}{8}$ " " coarse, with 386d " 1528j |
| 1912 | 2170 | " $1\frac{1}{8}$ " " fine, " 386d " 1528j |
| 24903 | 2170 | " Arm for 24904 and 24905 |
| 62677 | 2170 | " " " 62721 " 62722 |
| 16573 | 2170 | " " " 16581 " 16582 |
| 19442 | 540 | " " Bracket |
| 19443 | 540 | " " " Position Collar with 456al |
| 456al | 547 | " " " " " Set Screw |
| 987e | 547 | " " " Screw Stud |
| 19444 | 547 | " " " Spring |
| 19445 | 547 | " " " Pin |
| 19446 | 547 | Roller Arm Bracket Spring Stud |

| No. | Plate | |
|--|-------|--|
| 21445 | --- | Roller Arm Bracket Spring Stud , complete, Nos. 987e and 19444 to 19446 |
| 24904 | --- | Roller Presser , complete, $\frac{9}{16}$ " coarse roller, Nos. 24903 and 51801 |
| 24905 | --- | Roller Presser , complete, $\frac{9}{16}$ " fine roller, Nos. 24903 and 51802 |
| 62721 | --- | Roller Presser , complete, $\frac{7}{8}$ " coarse roller, Nos. 1868 and 62677 |
| 62722 | --- | Roller Presser , complete, $\frac{7}{8}$ " fine roller, Nos. 1841 and 62677 |
| 16581 | --- | Roller Presser , complete, $1\frac{1}{4}$ " coarse roller, Nos. 1911 and 16573 |
| 16582 | --- | Roller Presser , complete, $1\frac{1}{4}$ " fine roller, Nos. 1912 and 16573 |
| <i>NOTE: No. 16580 is sent with this Machine, unless otherwise specified on order.</i> | | |
| 190d | 2174 | Roller Presser Screw |
| 388d | 2174 | " Screw for 51801 and 51802 |
| 386d | 2174 | " " " 1911 " 1912 |
| 652d | 2174 | " " " 1841 " 1808 |
| 1550j | 567 | " " Nut for 51801 and 51802 |
| 1528j | 567 | " " " " 1841, 1868, 1911 and 1912 |
| 19131 | 1012 | Shuttle Bobbin |
| 20649 | 2162 | " " Case Latch |
| 2973 | 2202 | " " " " Lever |
| 2974 | 2202 | " " " " Fulcrum Pin |
| 2975 | 2202 | " " " " Spring |
| 592e | 2174 | " " " " Stop Screw |
| 20650 | 2162 | " " " Hinge, Nos. 2973, 2974 and 20649 |
| 24323 | 1012 | " " " Position Plate |
| 391j | 2174 | " " " " Screw |
| 20756 | 1012 | " " " with 591f, 592e, 2975, 20650 and 20651 |
| 20757 | 1012 | Shuttle Body |
| 591f | 2174 | " Tension Regulating Screw |
| 20654 | 1012 | " " Spring |
| 20758 | 2162 | Shuttle , $1\frac{1}{16}$ " diam., complete, Nos. 19131, 20756 and 20757 |
| 19406 | 1012 | Shuttle Driver with two 1266c |
| 2049 | 2162 | " " Pin |
| 1266c | 2174 | " " Set Screw |
| 2419 | 1012 | Shuttle Race Back |
| 2532 | 2169 | " " " Position Pin |
| 2533 | 2202 | " " " Spring |

| No. | Plate | |
|---------|-------|---|
| 907d | 567 | Shuttle Race Back Spring Screw |
| 24324 | --- | " " Body |
| 24999 | --- | " " " 24324, with 24009, two each 1053d and 2532 |
| 24009 | 1012 | " " Cap |
| 1053d | 567 | " " " Screw |
| 24325 | 1012 | Shuttle Race , complete, Nos. 907d, 2419, 2533, 24323, 21999 and two 391j |
| 145d | 2174 | Shuttle Race Screw (2) |
| 12431 | --- | Shuttle Race Slide |
| 4307 | 544 | " " " Spring |
| 725e | 2174 | " " " " Screw |
| 12432 | 544 | Shuttle Race Slide , complete, Nos. 4307, 12431 and two 725e |
| 20060 | 544 | Slack Thread Regulator |
| 225f | 2174 | " " " " Adjusting Screw |
| 2102 | 2169 | Tension Disc |
| 1560c | 567 | " Regulating Thumb Nut |
| 32572 | 2169 | " Releasing Disc |
| 43944 | 2162 | " " Lever |
| 12398 | 2169 | " " " Hinge Pin |
| 12329 | 2169 | " " " Spring |
| 32574 | 2169 | " " " Pin |
| *50327c | 2171 | " Screw Stud |
| 44141 | --- | " " " 50327c and 1560c |
| 43945 | 2162 | " Spring |
| 44118 | --- | Tension , complete, Nos. 7336, 32572, 32574, 43945, 43946, 44141 and two 2102 |
| 52454 | 2162 | Thread Retainer |
| 624c | 2174 | " " Set Screw |
| 12404 | 540 | Thread Take-up Crank |
| 3094 | 544 | " " " Wedge |
| 690e | 2174 | " " " " Screw |
| 12408 | 540 | Thread Take-up Lever |
| 775e | 2202 | " " " Cap Screw |
| 12166 | 544 | " " " Hinge Pin |
| 12409 | 540 | " " " Link |
| 11204 | 540 | " " " Hinge Pin |
| 435c | 2174 | " " " " " Set Screw |
| 12410 | --- | Thread Take-up Lever , complete, Nos. 12166, 12408 and 12409 |

| No. | Plate | |
|--|-------|---|
| 13946 | 2169 | Thread Take-up Spring |
| 7336 | 2170 | " " " Regulator |
| 448c | 2174 | " " " " Set Screw |
| 43990 | | Thread Take-up , complete, Nos. 775e, 11204, 12404, 12410 and 43997 |
| 12438 | 2167 | Throat Plate (large oblong needle hole) for 12436 and 20323 ... |
| 20192 | | " " (small " " " ") " 12436 and 20323 ... |
| 12452 | 2167 | " " (" " " ") " 12436 and 20323, raised at needle hole for top stitching |
| 20012 | 2167 | Throat Plate (large oblong needle hole) for 20011 |
| 20293 | | Throat Plate (small oblong needle hole) for 20011 |
| 691f | 2174 | Throat Plate Screw |
| <i>NOTE: No. 12438 is sent with this Machine, unless otherwise specified on order.</i> | | |
| 139622 | | Drip Pan with four $\frac{1}{4}$ " wire nails |
| 80864 | | " " " " Wood Screws $\frac{1}{4}$ " No. 5, for machines with S.D.V. |

PARTS COMPLETE

FOR

No. 31K47 MACHINE

DROP FEED. ALTERNATING PRESSERS,

For Medium and Heavy Enamelled or Plain Cloth and Fabrics
of uneven thickness.

| No. | Plate | | | | |
|--------|-------|--|-----|-----|-----|
| *20339 | - | Arm with 11104, 12453, 12454, 24131 and two 11119 | ... | ... | ... |
| 8582 | 2169 | " Dowel Pin (2) | ... | ... | ... |
| 12453 | 510 | " Oil Tube for Intermediate Bearing | ... | ... | ... |
| 12454 | 510 | " " " with 132590 for Oiling 12409 | ... | ... | ... |
| 15783 | 2169 | " " " (front of arm) | ... | ... | ... |
| 11119 | 510 | " " " (" " ") 15783 with 52045 for Oiling 12108 and 19365 | ... | ... | ... |
| 24131 | 510 | " Oil Tube with 52045 for Oiling 12197 | ... | ... | ... |
| 52045 | - | " " " Packing (Cotton Wick) | ... | ... | ... |
| 132590 | 2168 | " " " " (Braided Cotton) for 12454 | ... | ... | ... |
| 748e | 567 | " Screw (back) (2) | ... | ... | ... |
| 854e | 567 | " " (front) (2) | ... | ... | ... |
| 12427 | 535 | Arm Shaft | ... | ... | ... |
| *11104 | 539 | " " Bushing (front) | ... | ... | ... |
| 12357 | 539 | " " Flanged Bushing (back) | ... | ... | ... |
| 448c | 2174 | " " " " (") Set Screw | ... | ... | ... |
| 144c | 2174 | " " Screw | ... | ... | ... |
| 12193 | 544 | " Side Cover | ... | ... | ... |
| 51224d | 2171 | " " " Thumb Screw | ... | ... | ... |
| 12403 | 544 | " Spool Pin and Thread Eyelet (2) | ... | ... | ... |
| 11241 | 2168 | " " " Washer (Cloth) | ... | ... | ... |
| *12360 | - | Bed | ... | ... | ... |
| 256w | 2174 | Clamp Stop Motion Clamp Screw | ... | ... | ... |
| 248a | 2174 | " " " " Stop Screw | ... | ... | ... |
| 2020 | 539 | " " " " Washer | ... | ... | ... |
| *3023 | - | " " " " Flanged Bushing | ... | ... | ... |
| 4933 | 539 | " " " " " 3023 with two 462al | ... | ... | ... |
| 2022 | 2169 | " " " " " Pin | ... | ... | ... |
| 462al | 2174 | " " " " " Set Screw | ... | ... | ... |
| 3022j | - | Clamp Stop Motion, complete, Nos. 248a, 256w, 2020 and 4933 | ... | ... | ... |

| No. | Plate | |
|--|-------|--|
| 20197 | 535 | Crank Connecting Rod with 20198, 125044 and two 896e |
| *20198 | - | " " " " Cap |
| 896e | 567 | " " " " Screw |
| 908e | 567 | " " " " Hinge Screw |
| 1619e | 567 | " " " " Nut |
| 125044 | - | " " " " Oil Pad (felt) |
| 19354 | - | Face Plate |
| 44181 | 2169 | " " Thread Guard (lower) |
| 12150 | - | " " " " (") 44181 with 12152 |
| 12152 | 2169 | " " " " (") Rivet |
| 45874 | 2169 | " " " " (upper) |
| 139615 | 2169 | " " " " (") 45874 with 125424 |
| 125424 | 2169 | " " " " (") Rivet |
| 19355 | 2164 | Face Plate, complete, Nos. 12150, 19354 and 139615 |
| 219d | 2174 | " " Screw (2) |
| 12368 | 2163 | Feed Bar |
| 313c | 2171 | " " Screw Centre (2) |
| 1519e | 567 | " " Nut (2) |
| 52165 | 539 | Feed Connecting Link |
| 375c | 2174 | " " Hinge Screw (2) |
| 1518e | 567 | " " Nut (2) |
| 44252 | 2166 | Feed Dog, for Cloth, 12 Teeth (12 Teeth to the inch) |
| 20106 | 2167 | " " " " 13 Teeth (16 Teeth to the inch) |
| 12370 | 2167 | " " " " 15 Teeth (16 Teeth to the inch) |
| 44253 | 2166 | " " " " 16 Teeth (16 Teeth to the inch) |
| 43979 | - | " " " " 21 Teeth (22 Teeth to the inch) |
| 12481 | 2167 | " " " " 18 Teeth (16 Teeth to the inch) |
| 208al | 2174 | " " Screw (2) |
| <i>NOTE. No. 12481 is sent with this Machine, unless otherwise specified on order.</i> | | |
| 20283 | 539 | Feed and Feed Lifting Eccentric with 446e |
| 446e | 2174 | " " " " Set Screw |
| 24036 | 2170 | " " " " Sleeve |
| 20284 | 535 | Feed Forked Connection |
| 375c | 2174 | " " Hinge Screw |
| 1518e | 567 | " " Nut |
| 43993 | - | Feed Forked Connection, complete, Nos. 20284, 52165, 56886, two each 375c and 1518e |

| No. | Plate | |
|---------|-------|---|
| 44125 | 2164 | Feed Lifting Rock Shaft |
| 12376 | 539 | " " " " Crank with 157c and 1813 |
| 157c | 2174 | " " " " Clamping Screw |
| 1813 | 567 | " " " " Roller and Stud |
| 44126 | - | Feed Lifting Rock Shaft, complete, Nos. 12376 and 44125 |
| 43976 | 2164 | Feed Lifting Rock Shaft Crank Connecting Rod with 43977 and two 966e |
| *43977 | - | Feed Lifting Rock Shaft Crank Connecting Rod Cap |
| 966e | 2174 | " " " " " " " " " " Screw |
| 375c | 2171 | " " " " " " " " " " Hinge Screw |
| 1518e | 567 | " " " " " " " " " " Hinge Screw Nut |
| 307c | 2171 | " " " " " " " " " " Screw Centre (2) |
| 1513j | 567 | " " " " " " " " " " Nut (2) |
| 3039 | 540 | Feed Regulator |
| 56886 | - | " " 3039 with 818d |
| 140139e | 567 | " " Hinge Screw |
| 139603 | 2169 | " " Friction Washer |
| 818d | 567 | " " Thumb Screw |
| 12379 | 535 | Feed Rock Shaft |
| 29633 | 539 | " " " " Crank with 157c |
| 157c | 2174 | " " " " Clamping Screw |
| 307c | 2174 | " " " " Screw Centre (2) |
| 1513j | 567 | " " " " Nut (2) |
| 20333 | - | Feed Rock Shaft, complete, Nos. 12379 and 29633 |
| 25874 | 2171 | Guide for Raised Throat Plates |
| 25866 | 2171 | " " Flush Throat Plates |
| 284d | 2174 | " Thumb Screw for 25874 |
| 732d | 2174 | " " " " 25866 |
| 12391 | 535 | Lifting Presser Bar (hollow) |
| 19356 | 2162 | " " " " Bell Crank |
| 199d | 2174 | " " " " Cap Screw |
| 19357 | 2163 | " " " " Connecting Link |
| 199d | 2174 | " " " " Cap Screw |
| 19358 | 2162 | " " " " Driving Arm |
| 19362 | 2163 | " " " " Eccentric Connection |
| 62637 | - | " " " " Eccentric Connection 19362 with 19365 |

| No. | Plate | |
|--------|-------|---|
| 19449 | | Oscillating Shaft Crank Slide Block , complete, Nos. 226d, 988c, 12424 and 19448 |
| *19447 | | Oscillating Shaft Crank , complete, Nos. 457c, 4518c, 19419 and 19496 |
| 41135 | | Oscillating Shaft Crank , complete, Nos. 4518c, 19419, 41134 and two 453c |
| 688j | 567 | Pressure Regulating Thumb Screw |
| 2996 | 2202 | Shuttle Bobbin |
| 15140 | 2202 | " " Case Latch |
| 2973 | 2202 | " " " " Lever |
| 2974 | 2202 | " " " " Fulcrum Pin |
| 2975 | 2202 | " " " " Spring |
| 592c | 2174 | " " " " Stop Screw |
| 15141 | — | " " " " Hinge, Nos. 2973, 2974 and 15110 |
| 24412 | 2202 | " " " " Position Plate |
| 391j | 2174 | " " " " " " Screw |
| 62740 | 2162 | Shuttle Bobbin Case , with 591f, 592c, 2975, 15141 and 45278 |
| 12393 | 2202 | Shuttle Body |
| 591f | 2174 | " Tension Regulating Screw |
| 45278 | 2162 | " " Spring |
| 19292 | 2202 | Shuttle , 1 $\frac{1}{8}$ " diam., complete, Nos. 2996, 12393 and 62740 |
| *12394 | — | Shuttle Driver |
| 12444 | 2202 | " " 12394 with two 1266c |
| 2049 | 2162 | " " Pin |
| 1266c | 2174 | " " Set Screw |
| 2531 | 2202 | Shuttle Race Back |
| 2532 | 2169 | " " " " Position Pin |
| 2533 | 2202 | " " " " Spring |
| 907d | 567 | " " " " " " Screw |
| 24413 | 2168 | " " " " Body |
| 62502 | — | " " " " 24413 with 24418 and two 1053d |
| 24418 | 2162 | " " " " Cap |
| 1053d | 567 | " " " " " " Screw |
| 24419 | — | Shuttle Race , complete, Nos. 907d, 2531, 2533, 24412, 62502, two each 391j and 2532 |
| 145d | 2174 | Shuttle Race Screw (2) |
| 12431 | — | Shuttle Race Slide |

| No. | Plate | |
|--------|-------|--|
| 4307 | 511 | Shuttle Race Slide Spring |
| 725e | 2174 | " " " " " " Screw |
| 12432 | 511 | Shuttle Race Slide , complete, Nos. 4307, 12431 and two 725e |
| 2102 | 2169 | Tension Disc |
| 1560c | 567 | " Regulating Thumb Nut |
| 32572 | 2169 | " Releasing Disc |
| 43944 | 2162 | " " " " Lever |
| 12398 | 2169 | " " " " Hinge Pin |
| 12329 | 2169 | " " " " Spring |
| 32574 | 2169 | " " " " Pin |
| 50327c | 2171 | " Screw Stud |
| 44141 | — | " " " " 50327c with 1560c |
| 43945 | 2162 | " Spring |
| 42149 | 2170 | " Thread Guard |
| 44118 | — | Tension , complete, Nos. 7336, 32572, 32574, 43945, 43946, 44141 and two 2102 |
| 52454 | 2162 | Thread Retainer |
| 624c | 2174 | " " Set Screw |
| 12404 | 540 | Thread Take-up Crank |
| 3094 | 544 | " " " " Wedge |
| 690c | 2174 | " " " " " " Screw |
| 12408 | 540 | Thread Take-up Lever |
| 775c | 2202 | " " " " Cap Screw |
| 12166 | 544 | " " " " Hinge Pin |
| 12409 | 540 | " " " " Link |
| 11204 | 540 | " " " " " " Hinge Pin |
| 435c | 2174 | " " " " " " " " Set Screw |
| 12410 | — | Thread Take-up Lever , complete, Nos. 12166, 12408 and 12409 |
| 43946 | 2169 | Thread Take-up Spring |
| 7336 | 2170 | " " " " " " Regulator |
| 448c | 2174 | " " " " " " Set Screw |
| 43990 | — | Thread Take-up , complete, Nos. 775c, 11204, 12404, 12410 and 43997 |
| 12482 | — | Throat Plate (large needle hole) for 12481 |
| 20107 | 2167 | " " (small " " " " 20106 |
| 20315 | — | " " (large " " " " 20106 |
| 44255 | 2166 | " " (small " " " " 44252 and 44253 |
| 44256 | 2166 | " " (large " " " " 44252 and 44253 |
| 691f | 2174 | " " " " Screw (2) |

NOTE. No. 12482 is sent with this Machine, unless otherwise specified on order.

| No. | Plate | | | | | | |
|-------|-------|------------------------------|-----|-----|--------------------------|-----------------|-------|
| 44270 | 2202 | Vibrating Presser Bar | ... | ... | ... | ... | ... |
| 19367 | 2170 | " | " | " | Cap | ... | ... |
| 199d | 2174 | " | " | " | " | Screw for 44270 | ... |
| 219d | 2174 | " | " | " | " | " | 19367 |
| 19368 | 2169 | " | " | " | Cushion (rawhide) | ... | ... |
| 19369 | 2162 | " | " | " | Spring | ... | ... |
| 335d | 2174 | " | " | " | " | Screw | ... |
| 19370 | 2170 | " | " | " | Foot for 12370 and 43979 | ... | ... |
| 19374 | 2170 | " | " | " | " | 12457 | ... |

| | | | | | | | |
|-------|------|--------------------------|----------------|-----|-------|-----|-----|
| 19376 | 2170 | Vibrating Presser | Foot for 20106 | ... | ... | ... | ... |
| 217d | 2202 | " | " | " | Screw | ... | ... |

NOTE.—No. 19370 is sent with this Machine, unless otherwise specified on order.

| | | | | | | | |
|--------|--|-----------------|--------------------------------------|-----|-----|--|-----|
| 139622 | | Drip Pan | with four $\frac{3}{4}$ " wire nails | ... | ... | ... | ... |
| 80864 | | " | " | " | " | Wood Screws $\frac{1}{2}$ " No. 5 for machines with S.D.A. | ... |



Accessories

| No. | Plate | | | | |
|------------------------|-----------------|--|-----|-----|------------|
| 2996 | 2202 | Bobbins (2) for 31K19 and 31K17 Machines | ... | ... | ... |
| 19131 | 1012 | " (2) " 31K21 Machine | ... | ... | (Obsolete) |
| 12361 | 2171 | Machine Hinge Connection (2) | ... | ... | ... |
| 86720 30500 | 2171 | Oiler | ... | ... | ... |
| 25537 | 2171 | Screw Driver (machine) | ... | ... | ... |
| 120378 | 2171 | " " (shuttle tension) | ... | ... | ... |

16 X 6 - NEEDLES, SIX SIZE 11, FOR 31K 21 MACH.

16 X 113 - NEEDLES, THREE EACH SIZE 16 AND
18, FOR 31K 47 MACHINE.

CSMP

Bobbin Winders

BOBBIN WINDER (Friction), for Tight Machine Pulley No. 56898

| No. | Plate | |
|-------|-------|---|
| 12168 | 555 | Bracket |
| 692d | 2174 | " Screw |
| 12169 | 555 | Frame |
| 12171 | 555 | " complete, Nos. 333r, 5960, 5961, 5963, 12169 and 15077 |
| 32d | 2174 | Frame Hinge Screw |
| 5960 | 555 | Friction Wheel (Leather) |
| 5961 | 555 | " " Washer |
| 333r | 555 | " " " Screw |
| 15077 | 555 | Spindle with 15072 |
| 15072 | 2169 | " Bobbin Position Pin |
| 5963 | 555 | " Flange |
| 12170 | 2170 | Spring |
| 180d | 2174 | " Screw |
| 12172 | 2172 | Bobbin Winder , complete, Nos. 32d, 180d, 12168, 12170 and 12171 |

BOBBIN WINDER (Friction), for Loose Machine Pulleys Nos. 2135 and 2862

This Bobbin Winder is the same as 12172, with the following exceptions:—

| No. | Plate | |
|-------|-------|---|
| 43981 | 2164 | Frame |
| 93803 | — | Frame, complete, Nos. 333r, 5960, 5961, 5963, 15077 and 43981 |
| 93804 | | Bobbin Winder , complete, Nos. 32d, 180d, 12168, 12170 and 93803 |

BOBBIN WINDER (Friction), for Loose Machine Pulleys Nos. 2135 and 2862

(Export only)

This Bobbin Winder is the same as 12172, with the following exceptions:—

| No. | Plate | |
|-------|-------|---|
| 43981 | 2164 | Frame |
| 43982 | 2172 | Frame, complete, Nos. 5960, 5961, 5963, 12336, 15077 and 43981 |
| 12336 | 2164 | Spindle for Spool |
| 12337 | 2172 | Bobbin Winder , complete, Nos. 32d, 180d, 12168, 12170 and 43982 |

BOBBIN WINDER (Friction), for Tight Machine Pulley No. 12358

This Bobbin Winder is the same as 12172, with the following exceptions:—

| No. | Plate | |
|-------|-------|---|
| 20307 | 2164 | Frame |
| 20308 | 2172 | Frame, complete, Nos. 333r, 5960, 5961, 5963, 15077 and 20307 |
| 20309 | | Bobbin Winder , complete, Nos. 32d, 180d, 12168, 12170 and 20308 |

**BOBBIN WINDER (Swinging Automatic, Right Hand) for
No. 19131, for Machines when used on Stand**

(Obsolete)

This Bobbin Winder is the same as 27554 with the following exceptions:

| No. | Plate | |
|-------|-------|---|
| 27540 | 1458 | Base |
| 27541 | 1458 | Pulley |
| 27587 | 2164 | Stop Latch |
| 27875 | 2172 | Bobbin Winder, Nos. 35b, 1620j, 27302, 27303, 27538, 27540, 27541, 27587, 50356b and two Wood Screws 1" No. 7 |
| 27876 | --- | Bobbin Winder (Swinging Automatic, right hand), complete, Nos. 27308 and 27875 |

Knee Lifters

KNEE LIFTER for No. 31K21 Machine (Obsolete)

| No. | Plate | |
|-------|-------|-----------------------------------|
| 5596 | | Bell Crank |
| 5599 | | " " Bracket |
| 1786 | 2174 | " " " Screw |
| 5601 | 2169 | " " Hinge Pin |
| 5735 | 2170 | " " Spring |
| 5598 | 2171 | " " 5596 with 5599, 5601 and 5735 |
| 12237 | 535 | Lifting Lever with 448c |
| 12415 | 535 | " " Connecting Rod |
| 12416 | 2170 | " " " " Joint |
| 76d | 2174 | " " " " Hinge Screw |
| 1521e | 567 | " " " " Lock Nut |
| 802d | 567 | " " Hinge Screw |
| 12241 | 2163 | " " Link |
| 766d | 2174 | " " " Hinge Screw |
| 12240 | 2162 | " " Pin |
| 148c | 2174 | " " Set Screw |
| 2763 | 535 | Rock Shaft |
| 97502 | 1818 | " " Bracket |
| | | " " " Screw (Wood) 1" No. 10 |
| 2765 | 535 | " " Knee Arm with 1507e |
| 2766 | 535 | " " " " Hub with 356c |
| 1507e | | " " " " Position Nut |
| 356 | 2174 | " " " " Set Screw |
| 2768 | | " " " " 2765 with 2766 and 2767 |
| 2767 | 535 | " " " Plate with 356c |
| 356c | 2174 | " " " " Set Screw |
| 6337 | 535 | " " Lifting Bracket with two 356c |
| 2778 | 535 | " " " " Hook |
| 356c | 2174 | " " " " Set Screw |
| 356c | 2174 | " " " " Set Screw |
| 2770 | 535 | " " Stop Dog with 356c |
| 356c | 2174 | " " " " Set Screw |

| No. | Plate | |
|-------|-------|---|
| 84789 | 535 | Rock Shaft, complete, Nos. 2763, 2768, 2770, 2778, 6337, two 97502 and four Wood Screws 1" No. 10 |
| 84790 | -- | Knee Lifter , complete, Nos. 76d, 766d, 892d, 1521e, 5598, 12237, 12240, 12241, 12415, 12416, 84789 and two 178c |

KNEE LIFTER for Nos. 31K19 and 31K47 Machines.

This Knee Lifter is the same as 84790 with the following exceptions:

| No. | Plate | |
|-------|-------|---|
| 20340 | 2173 | Lifting Lever with 118c |
| 21301 | 2168 | " " Link |
| 9372 | 2163 | " " Pin |
| 99911 | -- | Knee Lifter , complete, Nos. 76d, 766d, 892d, 1521e, 5598, 12415, 12416, 19372, 20340, 21301, 84789 and two 178c |



Driving Attachment

| No. | Plat. | |
|--------|-------|--|
| 16592 | 536 | Balance Wheel (friction) with 7958, 16524 and two 435c |
| 16524 | " | " " Friction Ring (Leather) |
| 7958 | 2169 | " " " " Stop Pin |
| 24297 | 536 | " " Oil Cover |
| 210d | 2174 | " " " " Screw |
| 435c | 2174 | " " Set Screw |
| 16514 | | Bobbin Winder Frame |
| 32d | 2174 | " " " Hinge Screw |
| 16515 | 536 | Bobbin Winder Frame, complete, Nos. 333r, 5960, 5961, 5963, 15077 and 16514 |
| 5960 | 555 | Bobbin Winder Friction Wheel (Leather) |
| 5961 | 555 | " " " " Washer |
| 333r | 555 | " " " " Screw |
| 15077 | 555 | " " Spindle with 15072 |
| 15072 | 2169 | " " " Bobbin Position Pin |
| 5963 | 555 | " " " Flange |
| 27306 | 2164 | " " Spool Pin |
| 11241 | 2168 | " " " Washer (cloth) |
| 27307 | " | " " " Stand |
| †27308 | 2169 | Bobbin Winder Spool Stand, complete, Nos. 418c, 1562j, 2106, 10141, 11241, 27306, 27307, two each 2455 and Wood Screws 1" No. 10 |
| ‡2170 | 2170 | Bobbin Winder Spring |
| 180d | 2174 | " " " Screw |
| 16516 | 536 | " " Stop Latch with 152f and 1550h |
| 152f | 2174 | " " " " Adjusting Screw |
| 1550h | 567 | " " " " " " Nut |
| 75d | 2174 | " " " " Hinge Screw |
| 27303 | 2169 | " " " " Spring |
| 2269 | 2202 | " " " " Stop Pin |
| 2455 | 2202 | " " Tension Disc |
| 1562j | 567 | " " " Regulating Thumb Nut |
| 418c | 2202 | " " " Screw Stud |

† As No. 27308 can be supplied either Plated or Japanned, it is necessary when ordering, to state which is required.

| No. | Plat. | |
|-------|-------|--|
| 10141 | 2162 | Bobbin Winder Tension Spring |
| 2106 | 2162 | " " " Thread Guide |
| 16530 | 536 | Bracket |
| 692d | 2174 | " Screw |
| 16518 | 536 | Driving Arm with 2269, 2928 and two 15132 |
| 2928 | 2170 | " " Brake (Leather) |
| 15132 | 2169 | " " " Rivet |
| 12178 | 536 | " " Friction Plug (Wood) |
| 427c | 2174 | " " " " Adjusting Screw |
| 1508c | 567 | " " " " " " " Nut |
| 693d | 536 | " " Hinge Screw |
| 1579c | 536 | " " " " Nut |
| 12175 | 536 | " " Pitman |
| 20371 | 2170 | " " " Crank |
| 2022 | 2169 | " " " " Pin |
| 20372 | 536 | " " " " Spring |
| 65d | 2174 | " " " " Hinge Screw |
| 16522 | | Driving Arm, complete, Nos. 32d, 75d, 180d, 427c, 693d, 1508c, 1579c, 12170, 12178, 16515, 16516, 16518, 16530 and 27306 |
| 16594 | 536 | Driving Friction Pulley, 2 $\frac{3}{16}$ " diam., with 861d and 10236 |
| 10236 | 536 | " " " Centre Bearing |
| 861d | 2174 | " " " Stop Screw |
| 84278 | | Shaft Driving Pulley (sectional, grooved), 12" diam., with two 597c |
| 597c | 2174 | " " " Clamping Screw |
| 12179 | 536 | Starting Crank |
| 2022 | 2169 | " " Pin |
| 12477 | 536 | " " Shaft |
| 14176 | " | " " " 12477, with 12479, 20371 and two 2022 |
| 27636 | 536 | Treadle |
| 9082 | 2162 | " Bearing Cotter Pin |
| 27637 | 536 | " Pitman Rod (lower) |
| 27638 | 536 | " " " (") Spring |
| 84695 | 536 | " " " (upper) |
| 80223 | 536 | " " " Clamp with 361c |
| 361c | 2174 | " " " " Set Screw |
| 84696 | 536 | Treadle Pitman, complete, Nos. 2762, 27637, 27638, 80223 and 84695 |

| No. | Plate | |
|-------|-------|---|
| 2878 | 536 | Treadle Stand |
| | | " " Wood Screw 1" No. 16 |
| 2762 | 536 | " Stop Collar with 362c |
| 362c | 2174 | " " " Set Screw |
| 27642 | | Treadle, complete, Nos. 2878, 9082, 27636 and four Wood Screws 1" No. 16 |
| 84698 | | Treadle and Pitman, complete, Nos. 27642 and 84696 |
| 84788 | | Driving Attachment , complete, Nos. 240d, 692d, 12475, 16522, 16592, 16594, 20372, 24297, 27308, 44176, 84278, 84698 and two 65d |

