

Fig. N. Abb. N.	Part. N. Bestell N. Pezce N. Pieza N.	Qt. Anzahl	DESCRIZIONE	DESCRIPTION	DESCRIPTION	BENENNUNG	DESCRIPCION
◆	310353-4-00	1	biella con eccentrico e viti	con-rod and screws	bielle avec excentrique et vis		
★	308013-4-01	1	bussola destra completa	right bush assembly	bague droite complète		
■	308178-4-00	1	gruppo biella principale	main con-rod assembly	groupe bielle principale		
1	308254-3-00	1	biella con eccentrico e viti	con-rod with cam and screws	bielle avec excentrique et vis		
2	308310-0-00	1	perno a sfera	ball joint	pivot à sphère		
3	308802-0-00	2	vite per biella	screw for con-rod	vis pour bielle		
4	308855-0-00	1	vite	screw	vis		
5	308174-3-00	1	biella principale completa	main con-rod assembly	bielle principale complète		
6	741056-0-00	4	vite	screw	vis		
7	302272-0-10	2	settore	sector	secteur		
8	704869-0-00	1	rondella	washer	rondelle		
9	745815-2-00	2	vite	screw	vis		
10	308084-2-00	1	anello di registro con viti	adjustment ring with screws	bagua de réglage avec vis		
11	746408-2-00	1	dado	nut	écrou		
12	705013-0-00	1	rondella	washer	rondelle		
13	745812-2-00	2	vite	screw	vis		
14	308159-2-01	1	manovella	crank	manivelle		
15	308166-0-00	1	perno	pin	pivot		
16	308161-0-00	2	vite	screw	vis		
17	308149-0-01	2	rondella	washer	rondelle		
18	308162-0-00	2	dado	nut	écrou		
19	308127-0-00	1	guarnizione	gasket	garniture		
20	308012-2-01	1	bussola	bush	bagua		
21	730054-2-00	1	vite per volantino	screw for pulley	vis pour volant		
22	700596-0-00	1	anello di tenuta	retainer ring	bagua d'étanchéité		
23	742222-2-00	3	vite	screw	vis		
24	308090-0-00	1	volantino	handwheel	voiant		
25	729044-2-00	1	vite	screw	vis		

DESCRIPTION

BEVWUWUWU

DESCRIPTION

DESCRIPTION

DESCRIPTION

QTY	Part No	Part No	Part No
	Rev. 01	Rev. 01	Rev. 01
1	21022-4-00		
1	30811-4-01		
1	30813-4-00		
1	30824-3-00		
1	308310-0-00		
2	318205-0-00		
1	308282-0-00		
1	308114-3-00		
4	341082-0-00		
1	303233-0-10		
1	304882-0-00		
1	308281-0-00		
1	308004-2-00		
1	342402-2-00		
1	308013-0-00		
1	308183-2-00		
1	308182-0-00		
1	308181-0-00		
1	308180-0-01		
1	308179-0-00		
1	308178-0-00		
1	308177-0-00		
1	308176-0-00		
1	308175-0-00		
1	308174-0-00		
1	308173-0-00		
1	308172-0-00		
1	308171-0-00		
1	308170-0-00		
1	308169-0-00		
1	308168-0-00		
1	308167-0-00		
1	308166-0-00		
1	308165-0-00		
1	308164-0-00		
1	308163-0-00		
1	308162-0-00		
1	308161-0-00		
1	308160-0-00		
1	308159-0-00		
1	308158-0-00		
1	308157-0-00		
1	308156-0-00		
1	308155-0-00		
1	308154-0-00		
1	308153-0-00		
1	308152-0-00		
1	308151-0-00		
1	308150-0-00		
1	308149-0-00		
1	308148-0-00		
1	308147-0-00		
1	308146-0-00		
1	308145-0-00		
1	308144-0-00		
1	308143-0-00		
1	308142-0-00		
1	308141-0-00		
1	308140-0-00		
1	308139-0-00		
1	308138-0-00		
1	308137-0-00		
1	308136-0-00		
1	308135-0-00		
1	308134-0-00		
1	308133-0-00		
1	308132-0-00		
1	308131-0-00		
1	308130-0-00		
1	308129-0-00		
1	308128-0-00		
1	308127-0-00		
1	308126-0-00		
1	308125-0-00		
1	308124-0-00		
1	308123-0-00		
1	308122-0-00		
1	308121-0-00		
1	308120-0-00		
1	308119-0-00		
1	308118-0-00		
1	308117-0-00		
1	308116-0-00		
1	308115-0-00		
1	308114-0-00		
1	308113-0-00		
1	308112-0-00		
1	308111-0-00		
1	308110-0-00		
1	308109-0-00		
1	308108-0-00		
1	308107-0-00		
1	308106-0-00		
1	308105-0-00		
1	308104-0-00		
1	308103-0-00		
1	308102-0-00		
1	308101-0-00		
1	308100-0-00		
1	308099-0-00		
1	308098-0-00		
1	308097-0-00		
1	308096-0-00		
1	308095-0-00		
1	308094-0-00		
1	308093-0-00		
1	308092-0-00		
1	308091-0-00		
1	308090-0-00		
1	308089-0-00		
1	308088-0-00		
1	308087-0-00		
1	308086-0-00		
1	308085-0-00		
1	308084-0-00		
1	308083-0-00		
1	308082-0-00		
1	308081-0-00		
1	308080-0-00		
1	308079-0-00		
1	308078-0-00		
1	308077-0-00		
1	308076-0-00		
1	308075-0-00		
1	308074-0-00		
1	308073-0-00		
1	308072-0-00		
1	308071-0-00		
1	308070-0-00		
1	308069-0-00		
1	308068-0-00		
1	308067-0-00		
1	308066-0-00		
1	308065-0-00		
1	308064-0-00		
1	308063-0-00		
1	308062-0-00		
1	308061-0-00		
1	308060-0-00		
1	308059-0-00		
1	308058-0-00		
1	308057-0-00		
1	308056-0-00		
1	308055-0-00		
1	308054-0-00		
1	308053-0-00		
1	308052-0-00		
1	308051-0-00		
1	308050-0-00		
1	308049-0-00		
1	308048-0-00		
1	308047-0-00		
1	308046-0-00		
1	308045-0-00		
1	308044-0-00		
1	308043-0-00		
1	308042-0-00		
1	308041-0-00		
1	308040-0-00		
1	308039-0-00		
1	308038-0-00		
1	308037-0-00		
1	308036-0-00		
1	308035-0-00		
1	308034-0-00		
1	308033-0-00		
1	308032-0-00		
1	308031-0-00		
1	308030-0-00		
1	308029-0-00		
1	308028-0-00		
1	308027-0-00		
1	308026-0-00		
1	308025-0-00		
1	308024-0-00		
1	308023-0-00		
1	308022-0-00		
1	308021-0-00		
1	308020-0-00		
1	308019-0-00		
1	308018-0-00		
1	308017-0-00		
1	308016-0-00		
1	308015-0-00		
1	308014-0-00		
1	308013-0-00		
1	308012-0-00		
1	308011-0-00		
1	308010-0-00		
1	308009-0-00		
1	308008-0-00		
1	308007-0-00		
1	308006-0-00		
1	308005-0-00		
1	308004-0-00		
1	308003-0-00		
1	308002-0-00		
1	308001-0-00		
1	308000-0-00		

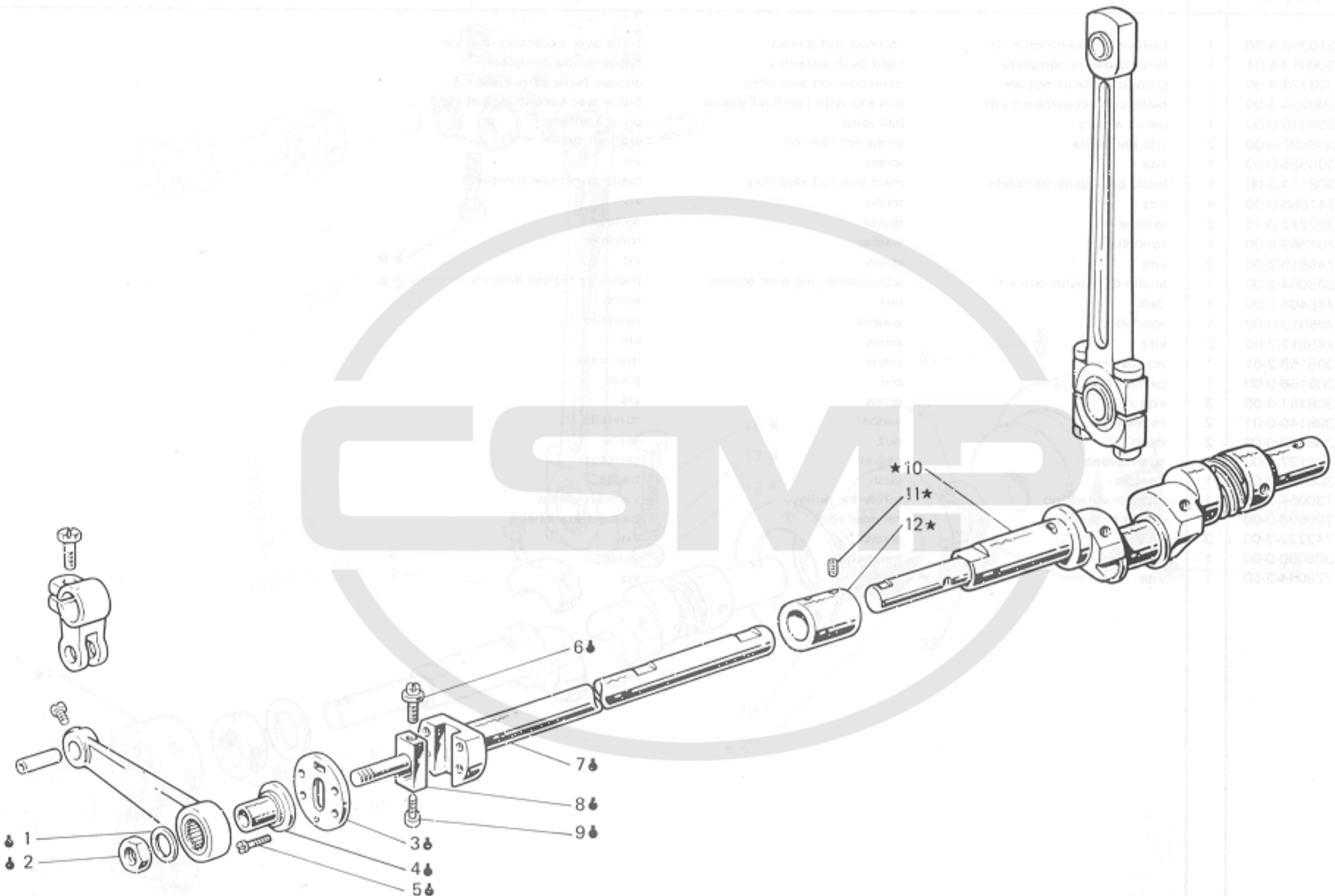

Fig. N. Abb. N.	Part. N. Besteli N. Piece N. Pieza N.	Ct. Anzahl	DESCRIZIONE	DESCRIPTION	DESCRIPTION	BENENNUNG	DESCRIPCION
★	309711-4-01	1	gruppo albero inf. compi. (con fig. 1)	lower shaft assembly (with fig. 1)	arbre inférieur complet (avec fig. 1)		
1	308362-4-01	1	semialbero inf. sinistro compl.	left lower shaft assembly	semi-arbre inf. gauche compl.		
2	704814-0-00	1	rondella	washer	rondelle		
3	746612-2-00	1	dado	nut	écrou		
4	308774-2-00	1	piastra a disco	disc plate	plaque		
5	303458-0-12	1	bussola	bush	bague		
6	724441-0-00	4	vite	screw	vis		
7	308281-0-00	1	vite di registro	screw	vis		
8	308385-2-01	1	semialbero	half-shaft	semi-arbre		
9	308278-0-01	1	perno	pin	pivot		
10	308780-2-00	1	vite di registro	screw	vis		
11	308714-3-01	1	semialbero inf. destro	right lower half-shaft	semi-arbre inf.droite		
12	745827-2-00	4	vite per manicotto	screw for coupling	vis pour manchon		
	308015-0-00	1	manicotto	coupling	manchon		

DESIGNATION

BENENNING

DESCRIPTION

DESCRIPTION

DESCRIPTION

QTY

Part N.  
Original N.  
Part N.  
Part N.

QTY

308314-01  
308363-01  
308314-00  
308313-00  
308374-00  
308358-01  
308351-00  
308352-01  
308378-01  
308380-00  
308314-01  
308373-00  
308318-00

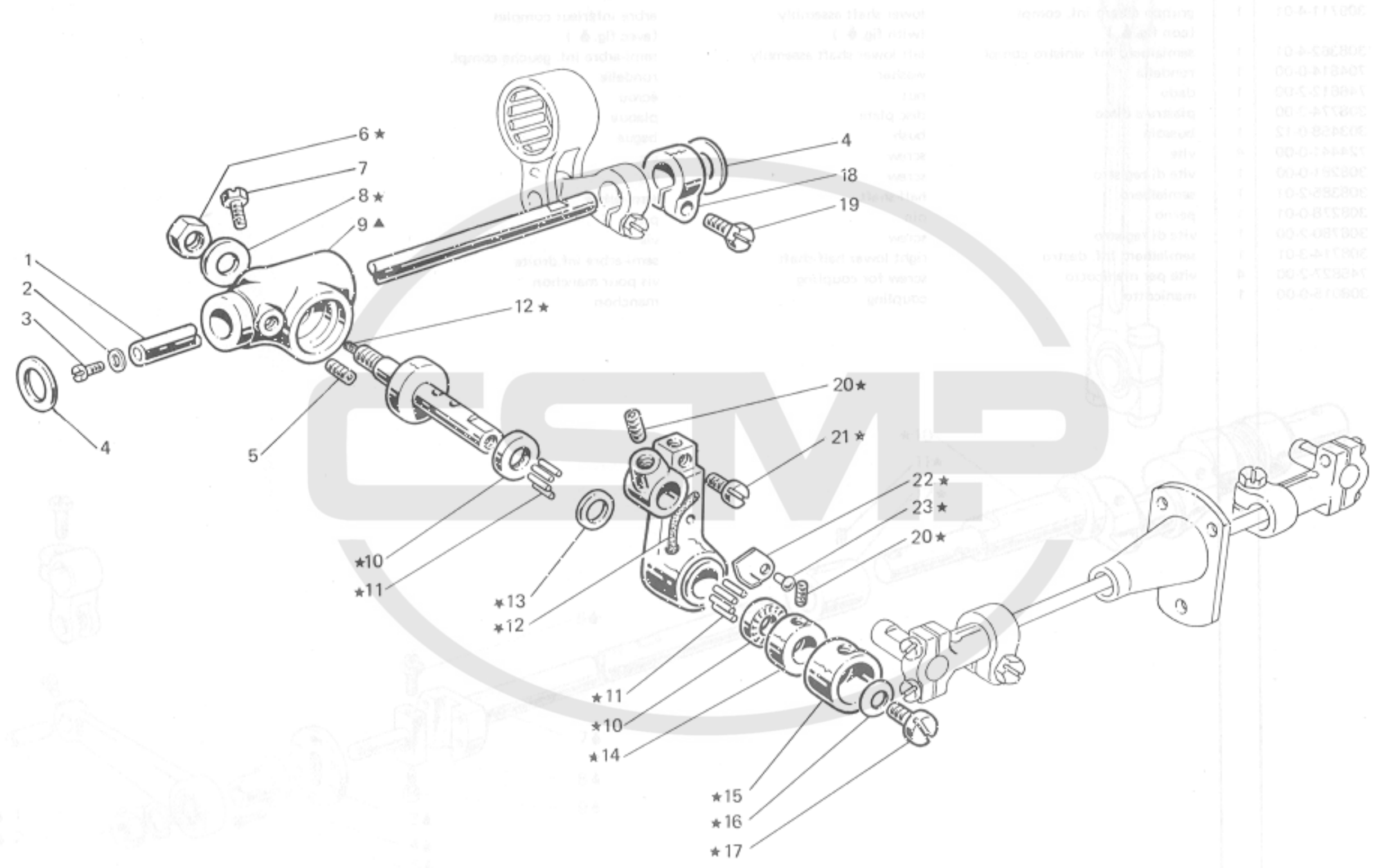

Fig. N. Abb. N.	Part. N. Bestell N. Piece N. Pieza N.	Qt. Anzahl	DESCRIZIONE	DESCRIPTION	DESCRIPTION	BENENNUNG	DESCRIPCION
▲	308261-4-00	1	gruppo porta crochet inf. (con fig. ★ )	lower looper holder assembly (with fig. ★ )	groupe porte-crochet inférieur (avec fig. ★ )		
★	312810-3-00	1	gruppo porta corchet	looper holder assembly	groupe porta crochet		
1	308292-4-00	1	contralb.crochet inf.compl.	lower looper countershaft ass.	axs crochet inf. complet		
2	705734-0-00	1	guarnizione	gasket	garniture		
3	742214-2-00	1	vite	screw	vis		
4	704846-0-00	2	rondella	washer	rondelle		
5	730033-2-00	1	vite	screw	vis		
6	202474-0-10	1	dado	nut	écrou		
7	740226-0-00	1	vite per supporto	screw for support	vis pour support		
8	704226-2-00	1	rondella	washer	rondelle		
9	308140-0-00	1	supporto del porte crochet	support for looper holder	support du porte crochet		
10	303539-0-00	2	reggispinta	thrust bearing	butée		
11	302276-0-10	40	rullino	roller	rouleau		
12	778827-0-00	2	stoppino	wick	mèche		
13	703810-0-00	1	distanziale	spacer	entretoise		
14	302052-2-21	1	ghiera con viti	ring with screw	collier avec vis		
15	303538-0-00	1	cappello di protezione	protection cap	capuchon de protection		
16	702403-0-00	1	molla a tazza	cup spring	ressort à tasse		
17	742423-0-00	1	vite	screw	vis		
18	300469-2-11	1	fascetta	clamp	bride		
19	300482-0-10	1	vite	screw	vis		
20	745815-2-00	3	vite	screw	vis		
21	303503-0-10	1	vite fissa crochet	looper fixing screw	vis blocage crochet		
22	308272-0-00	1	piastrina	sheet	plaquette		
23	308273-0-00	1	rivetto	rivet	rivet		

DESCRIPTION

BENENNUNG

DESCRIPTION

DESCRIPTION

DESCRIZIONE

Fig. N°	Part. N°	Part. N°	Part. N°	Part. N°
4	308281-4-00			
4	313810-3-00			
1	308282-4-00			
2	308124-0-00			
3	343214-3-00			
4	308240-0-00			
5	330033-3-00			
6	302475-0-10			
7	340326-0-00			
8	304326-3-00			
9	308140-0-00			
10	303209-0-00			
11	303326-0-10			
12	138823-0-00			
13	308210-0-00			
14	302082-3-21			
15	308236-0-00			
16	302403-0-00			
17	343423-0-00			
18	300462-3-18			
19	308183-0-00			
20	308183-0-10			
21	308183-0-10			
22	308183-0-10			
23	308183-0-10			

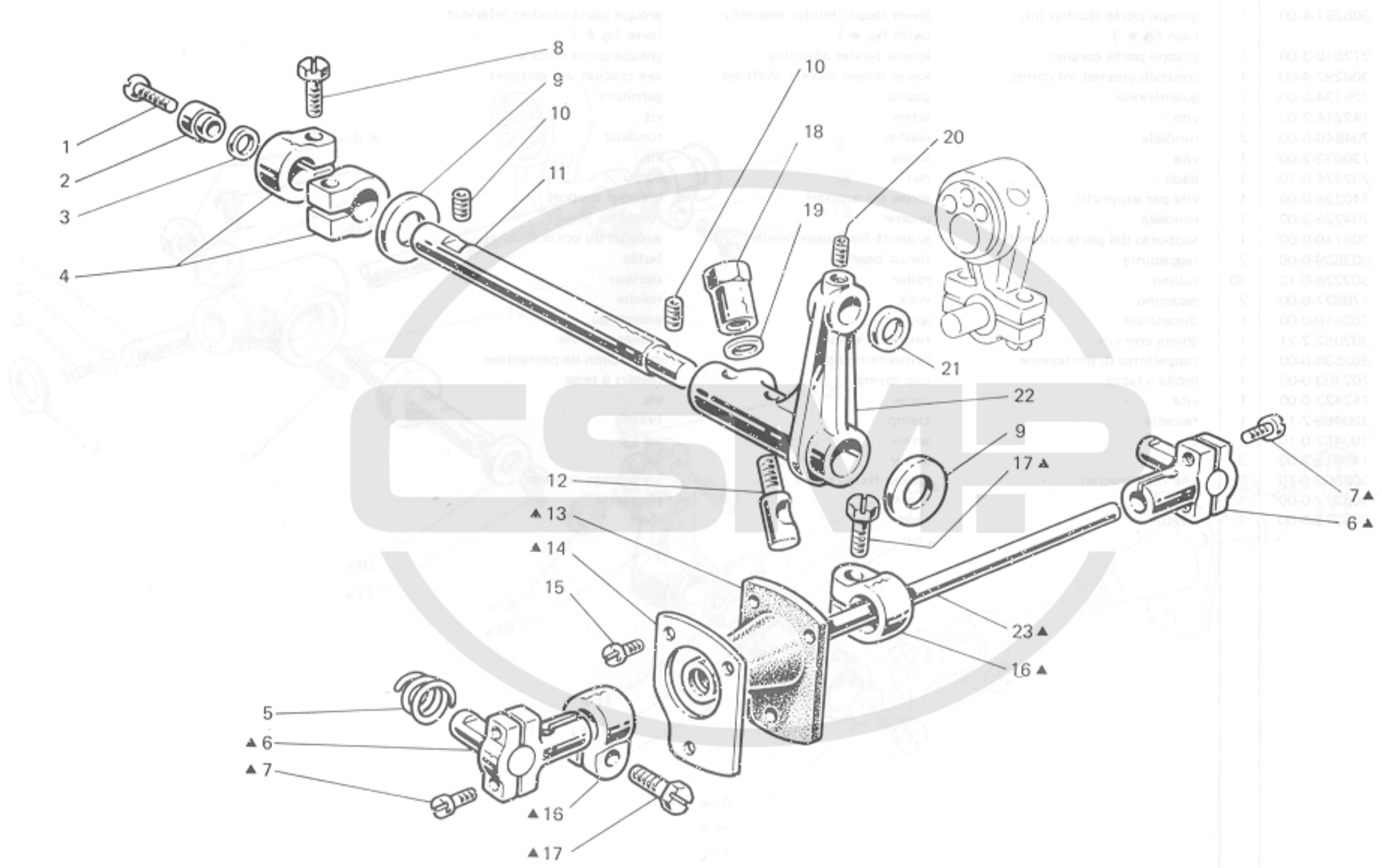

Fig. N. Abb. N.	Part. N. Bestell N. Piece N. Pieza N.	Qt. Anzahl	DESCRIZIONE	DESCRIPTION	DESCRIPTION	BENENNUNG	DESCRIPCION
▲	308332-4-00	1	gruppo comando crochet inf.	lower looper control assembly	groupe comm. crochet inférieur		
1	744676-2-00	1	vite	screw	vis		
2	308047-0-00	1	scodellino	cup	cuvette		
3	701009-0-00	1	anello di tenuta	retainer ring	bague d'étanchéité		
4	308046-2-01	2	fascetta	clamp	bride		
5	302289-0-10	1	molla	spring	ressort		
6	308325-3-00	2	testa di biella con viti	con-rod big end with screws	tête de bielle avec vis		
7	744040-2-00	4	vite	screw	vis		
8	300482-0-10	2	vite	screw	vis		
9	704849-0-00	2	rondella	washer	rondelle		
10	729434-2-00	2	vite fissa perno	screw	vis		
11	308044-0-00	1	perno per supporto	pin	pivot		
12	300352-0-10	1	spina filettata	pin	goupille		
13	308330-3-00	1	manicotto para olio	oil protection	manchon para huile		
14	308327-0-00	1	mascherina per manicotto	flange	flasque		
15	741675-2-00	2	vite	screw	vis		
16	308326-2-01	2	fascetta per biella con vite	clamp with screw	bride avec vis		
17	305194-0-00	2	vite	screw	vis		
18	300351-0-11	1	dado	nut	écrou		
19	704309-4-00	1	rondella	washer	rondelle		
20	745815-2-00	1	vite	screw	vis		
21	705834-0-00	1	rondella in fibra	washer	rondelle		
22	308045-0-01	1	supporto oscillante	support	support coulissant		
23	308333-0-01	1	tirante per biella	tie-rod	tirant pour bielle		



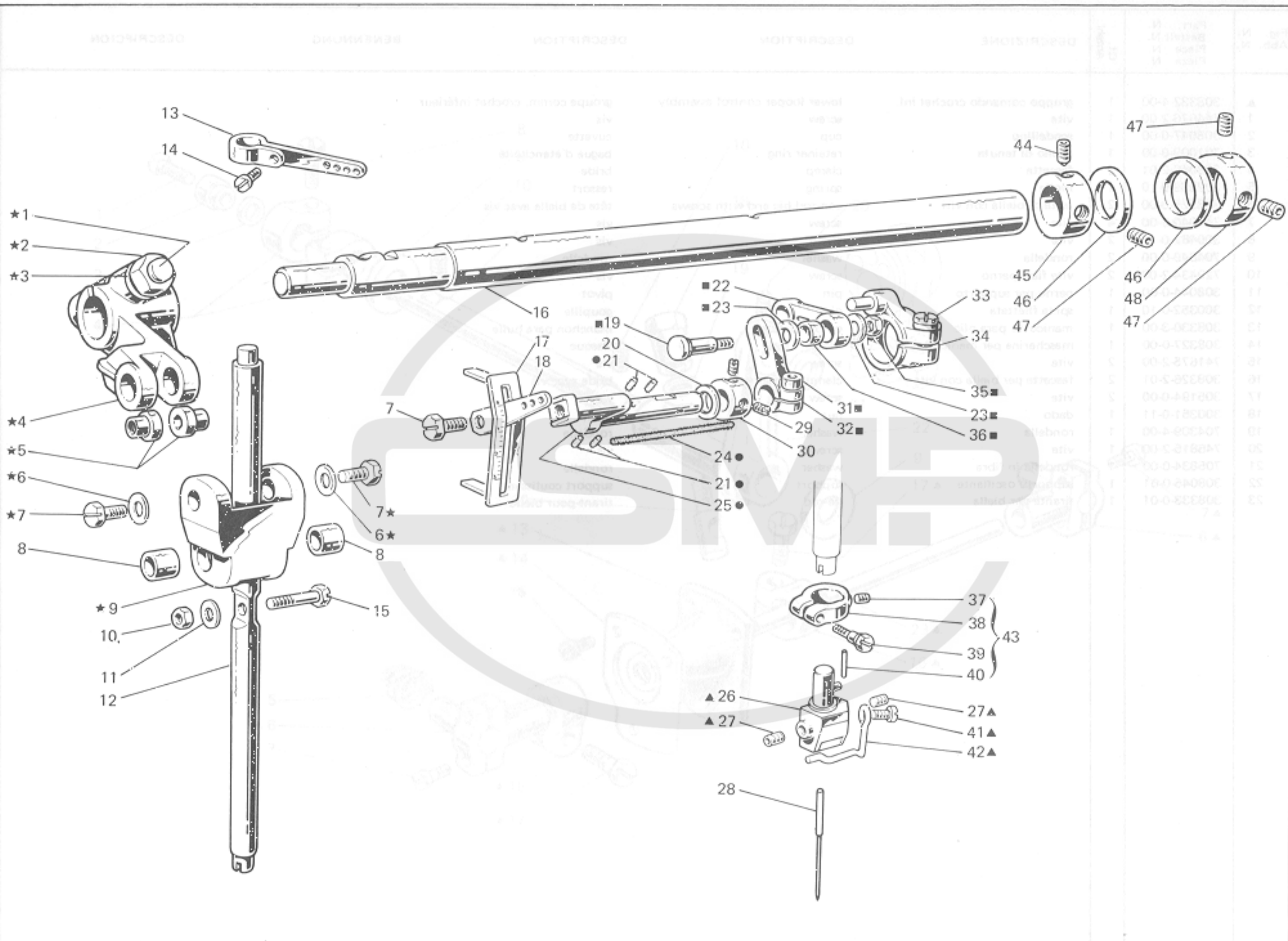
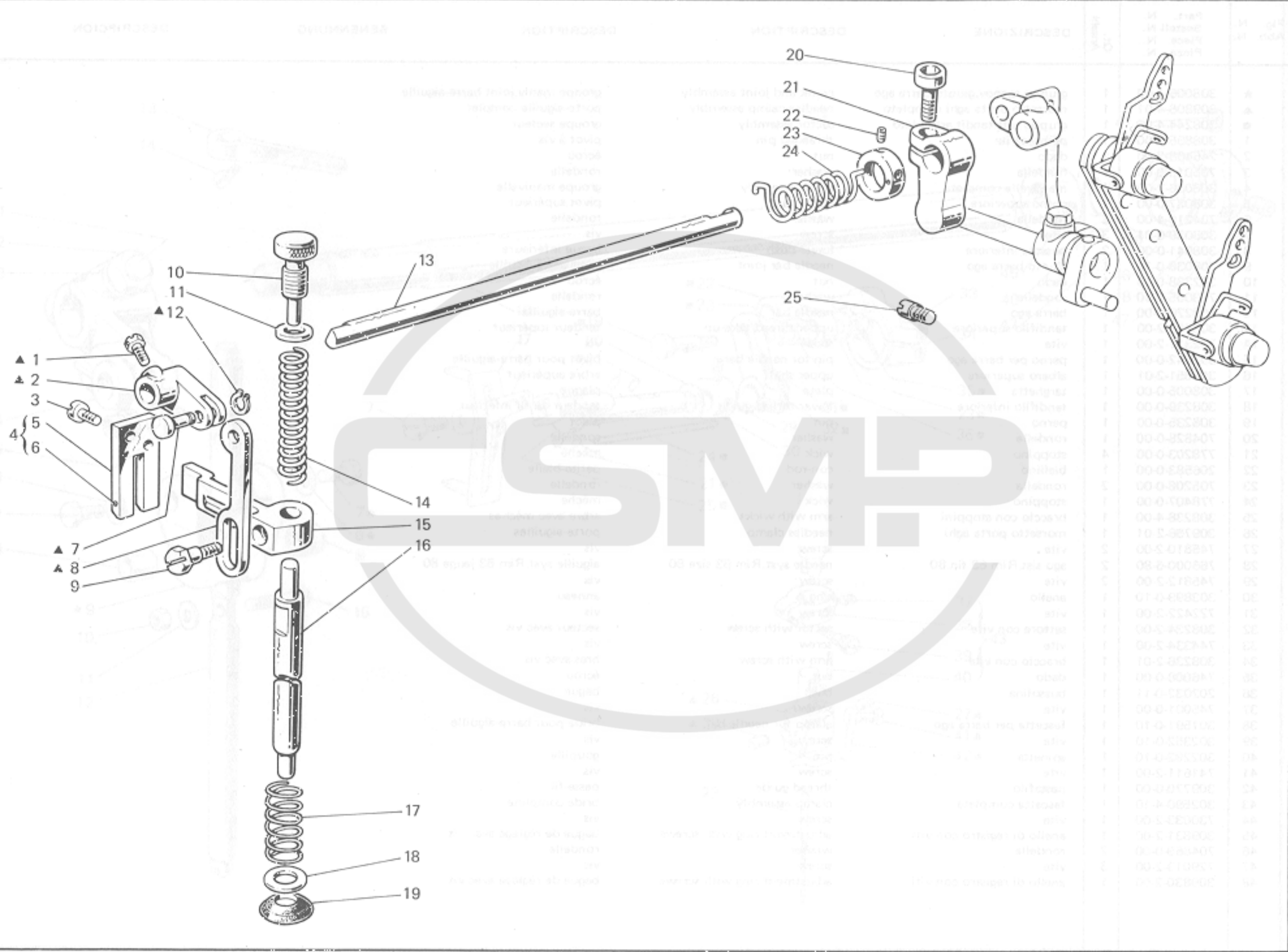

Fig. N. Abb. N.	Part. N. Bestell N. Pieze N. Pieza N.	Qt. Anzahl	DESCRIZIONE	DESCRIPTION	DESCRIPTION	BENENNUNG	DESCRIPCION
★	308006-4-00	1	gruppo manov.giunto barra ago	crank and joint assembly	groupe maniv.joint barre-aiguille		
▲	309806-4-01	1	morsetto porta aghi completo	needles clamp assembly	porte-aiguille complet		
■	308244-4-00	1	gruppo sett.tendit.articolato	sector assembly	groupe secteur		
1	308855-0-00	1	perno a vite	threaded pin	pivot à vis		
2	746408-2-00	1	dado	nut	écrou		
3	705013-0-00	1	rondella	washer	rondelle		
4	308036-2-00	1	manovella completa	crank assembly	groupe manivelle		
5	308037-0-00	2	perno superiore	upper pin	pivot supérieur		
6	704210-4-00	2	rondella	washer	rondelle		
7	308039-0-01	3	vite	screw	vis		
8	308041-0-00	2	bussola inferiore	lower bush	bague inférieure		
9	308038-0-10	1	giunto barra ago	needle bar joint	joint barre-aiguille		
10	302338-0-10	1	dado	nut	écrou		
11	703005-0-00	1	rondella	washer	rondelle		
12	308220-0-00	1	barra ago	needle bar	barre-aiguille		
13	308452-2-00	1	tendifilo superiore	upper thread take-up	tendeur supérieur		
14	742311-2-00	1	vite	screw	vis		
15	308042-0-00	1	perno per barra ago	pin for needle bar	pivot pour barre-aiguille		
16	308851-2-01	1	albero superiore	upper shaft	arbre supérieur		
17	308005-0-00	1	targhetta	plate	plaque		
18	308239-0-00	1	tendifilo inferiore	lower thread guide	tendeur du fil inférieur		
19	308235-0-00	1	perno	pin	pivot		
20	704828-0-00	1	rondella	washer	rondelle		
21	778203-0-00	4	stoppino	wick	mèche		
22	206583-0-00	1	biellino	con-rod	petite bielle		
23	705208-0-00	2	rondella	washer	rondelle		
24	778407-0-00	1	stoppino	wick	mèche		
25	308238-4-00	1	braccio con stoppini	arm with wicks	arbre avec mèches		
26	309755-2-01	1	morsetto porta aghi	needles clamp	porte-aiguilles		
27	745810-2-00	2	vite	screw	vis		
28	766000-6-80	2	ago sist.Rim 63 fin.80	needle syst.Rim 63 size 80	aiguille syst.Rim 63 jauge 80		
29	745812-2-00	2	vite	screw	vis		
30	303899-0-10	1	anello	ring	anneau		
31	722422-2-00	1	vite	screw	vis		
32	308234-2-00	1	settore con vite	sector with screw	secteur avec vis		
33	744334-2-00	1	vite	screw	vis		
34	308236-2-01	1	braccio con vite	arm with screw	bras avec vis		
35	746008-0-00	1	dado	nut	écrou		
36	202032-0-11	1	bussolina	bush	bague		
37	745001-0-00	1	vite	screw	vis		
38	301591-0-10	1	fascetta per barra ago	clamp for needle bar	bride pour barre-aiguille		
39	302352-0-10	1	vite	screw	vis		
40	302292-0-10	1	spinetta	pin	goupille		
41	741611-2-00	1	vite	screw	vis		
42	309770-0-00	1	passafilo	thread guide	passe-fil		
43	302590-4-10	1	fascetta completa	clamp assembly	bride complète		
44	730033-2-00	1	vite	screw	vis		
45	309831-2-00	1	anello di registro con viti	adjustment ring with screws	bague de réglage avec vis		
46	704869-0-00	2	rondella	washer	rondelle		
47	729013-2-00	3	vite	screw	vis		
48	309830-2-00	1	anello di registro con viti	adjustment ring with screws	bague de réglage avec vis		



CSMP

Part No.	Description	QTY	Part No.	Description	QTY
1	Pin	1	16	Pin	1
2	Pin	1	17	Spring	1
3	Pin	1	18	Pin	1
4	Pin	1	19	Pin	1
5	Pin	1	20	Pin	1
6	Pin	1	21	Pin	1
7	Pin	1	22	Pin	1
8	Pin	1	23	Pin	1
9	Pin	1	24	Pin	1
10	Pin	1	25	Pin	1
11	Pin	1			
12	Pin	1			
13	Pin	1			
14	Pin	1			
15	Pin	1			
16	Pin	1			
17	Pin	1			
18	Pin	1			
19	Pin	1			
20	Pin	1			
21	Pin	1			
22	Pin	1			
23	Pin	1			
24	Pin	1			
25	Pin	1			

Fig. N. Abb. N.	Part. N. Bestell N. Piece N. Pieza N.	Qt. Anzahl	DESCRIZIONE	DESCRIPTION	DESCRIPTION	BENENNUNG	DESCRIPCION
★	308625-3-00	1	base e braccio con bussola	base and arm with bushes	base et bras avec bague		
1	706454-0-00	2	spina	pin	goupille		
2	308859-2-00	1	supporto con bussola	support with bush	support avec bague		
3	721485-2-00	4	vite	screw	vis		
4	202398-0-10	1	tappo	plug	bouchon		
5	308032-0-00	1	bussola	bush	bague		
6	308215-0-00	1	protezione olio	oil protection	protection huile		
7	308858-0-00	1	bussola	bush	bague		
8	308406-0-00	1	bussola	bush	bague		
9	308218-0-00	1	scodellino inferiore	lower cup	cuvette inférieur		
10	308296-0-00	2	bussola	bush	bague		
11	308293-0-01	1	bussola	bush	bague		
12	308297-0-00	1	bussola	bush	bague		
13	721444-2-00	1	vite	screw	vis		
14	308138-0-12	1	carter paraolio	oil retainer cover	carter pare-huile		
15	308094-0-00	1	tappo foro bussola	plug	bouchon		
16	308031-0-00	1	bussola	bush	bague		
17	303501-0-10	1	tappo per foro tendifilo	plug	bouchon		
18	308852-0-00	1	bussola	bush	bague		
19	308232-0-00	1	bussola	bush	bague		
20	729032-2-00	1	vite	screw	vis		
21	308086-0-10	1	bussola	bush	bague		
22	308009-0-00	1	bussola	bush	bague		
23	308298-0-00	1	bussola	bush	bague		
24	302356-0-10	1	tappo	plug	bouchon		
25	308853-0-00	2	bussola	bush	bague		
26	706302-4-00	1	mandrillo	mandrel			
27	302790-0-11	1	mandrillo	mandrel			
28	311092-2-00	2	bussola	bush	bague		
29	7042185-00	1	mandrillo	mandrel			
30	300485-70	4	vite	screw	vis		
31	300346-70	4	vite	screw	vis		
32	300110-0-01	2	guida filo	thread guide	guide		

Fig. N. Abb. N.	Part. N. Piece N. Bestell N. Pieza N.	Qt. Anzahl	DESCRIZIONE	DESCRIPTION	DESCRIPTION	BENENNUNG	DESCRIPCION
▲	308060-4-00	1	gruppo manov.tirante premist.	presser crank assembly	groupe maniv. tirant presseur		
1	740632-2-00	1	vite	screw	vis		
2	308059-0-00	1	manovella	crank	manivelle		
3	721494-2-00	2	vite fissa piastra	plate screw	vis blocage plaque		
4	308052-4-00	1	piastra guida barra compl.	plate assembly	plaque complète		
5	308056-0-01	1	piastra guida barra	plate	plaque		
6	707240-0-00	1	spina elastica	split pin	goupille réglable		
7	308058-0-00	1	spina	pin	goupille		
8	308057-0-00	1	tirante per alza piedino	presserfoot tie-rod	tirant soulèv. pied-presseur		
9	740444-2-00	1	vite fissa slitta	screw	vis		
10	302060-0-11	1	pomolo di regolazione	adjustment knob	pommeau de réglage		
11	302344-0-10	1	rondella	washer	rondelle		
12	700205-0-00	1	anello elastico	spring ring	anneau ressort		
13	302234-0-10	1	albero	shaft	arbre		
14	302059-0-10	1	molla premi piedino	spring	ressort		
15	308055-2-00	1	guida a forcella	fork guide	guide a fourchette		
16	308061-0-01	1	barra porta piedino	presserfoot bar	barre porte pied-presseur		
17	308148-0-00	1	molla	spring	ressort		
18	704236-2-00	1	rondella	washer	rondelle		
19	308054-0-01	1	paraolio	oil retainer	pare-huile		
20	744332-2-00	1	vite	screw	vis		
21	308412-2-02	1	fascetta di fermo con vite	clamp with screw	bride de fixation avec vis		
22	745827-2-00	2	vite	screw	vis		
23	304767-2-10	1	anello per molla	ring	bague		
24	308098-0-00	1	molla di torsione	spring	ressort de torsion		
25	308007-0-00	1	perno filettato	threaded pin	pivot fileté		
	300073-2-00	1	vite	screw	vis		
	308767-2-00	1	eccentrica con vite	eccentric with screw	éxcentrique avec vis		
	307125-0-00	1	trapez.	trapez.	trapez.		
	302708-3-01	1	chiodo	nail	clou		
	307134-0-00	1	incauto storico	knuckle	axe boîtier		
SOLLO A RICHIESTA							
	306741-0-00	1	bloccetto per passante 10 mm	block for pass 10 mm	bloc pour passant 10 mm		
	306212-0-00	1	bloccetto per passante 12 mm	block for pass 12 mm	bloc pour passant 12 mm		
	306321-0-00	1	bloccetto per passante 15 mm	block for pass 15 mm	bloc pour passant 15 mm		
	306340-0-00	1	bloccetto per passante 18 mm	block for pass 18 mm	bloc pour passant 18 mm		
	306313-2-00	2	vite	screw	vis		

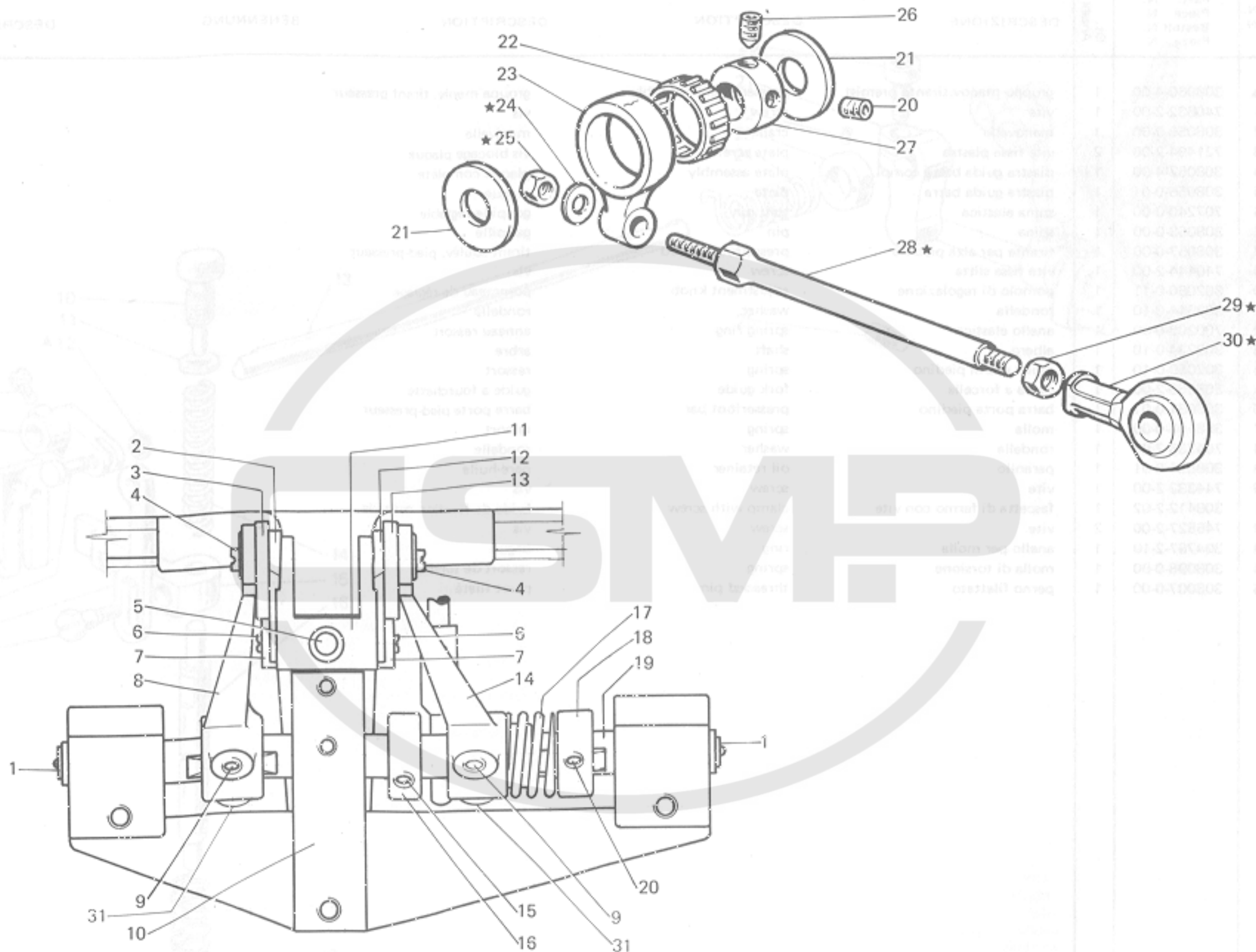

QTY	DESCRIPTION	REF. NO.	UNIT
1	...	20	...
1	...	21	...
1	...	22	...
1	...	23	...
1	...	24	...
1	...	25	...
1	...	26	...
1	...	27	...
1	...	28	...
1	...	29	...
1	...	30	...
1	...	31	...

Fig. N. Abb. N.	Part. N. Piece N. Bestell N. Pieza N.	Qt. Anzahl	DESCRIZIONE	DESCRIPTION	DESCRIPTION	BENENNUNG	DESCRIPTION
★	927133-4-00	1	gruppo biella	con-rod assembly	groupe bielle		
1	927910-0-00	2	ingrassatore	grease nipple	graisseur		
2	306284-2-00	1	coltello inf.sin. in lega dura	left lower knife (hard alloy)	couteau inf. gauche (alliage dur)		
3	306286-2-00	1	coltello superiore sinistro	left upper knife	couteau superieur gauche		
4	721443-2-00	2	vite fissa coltello	screw	vis		
5	722441-2-00	1	vite fissa blocchetto	screw	vis		
6	741956-2-00	2	vite	screw	vis		
7	306242-3-02	2	staffa fissa coltelli	bracket	bride		
8	927128-2-00	1	braccio sinistro	left arm	bras gauche		
9	729434-2-00	2	vite	screw	vis		
10	927127-4-00	1	supporto	support	support		
11	306300-0-00	1	blocchetto (per passante 8 mm)	block (for belt loop 8 mm)	bloc (pour passant 8 mm)		
12	306283-2-00	1	coltello inf. destro (lega dura)	right lower knife (hard alloy)	couteau inf. droite (alliage dur)		
13	306285-2-00	1	coltello superiore destro	upper right knife	couteau superieur droite		
14	927129-2-00	1	braccio destro	right arm	bras droite		
15	730034-2-00	1	vite	screw	vis		
16	927132-2-00	1	leva comando coltelli	knife lever control	levier commande couteaux		
17	927149-0-00	1	molla	spring	ressort		
18	100431-0-11	1	anello carico molla	ring	anneau		
19	927136-2-00	1	perno oscillante compl.	pin assembly	pivot complet		
20	729013-2-00	6	vite	screw	vis		
21	703825-0-00	2	rondella	washer	rondelle		
22	302857-0-10	1	gabbia a rullini	needles cage	cage à aiguilles		
23	302812-0-10	1	giunto	joint	joint		
24	703208-0-00	1	rondella elastica	spring washer	rondelle élastique		
25	746204-2-00	1	dado	nut	écrou		
26	730023-2-00	1	vite	screw	vis		
27	308762-2-00	1	eccentrico con viti	eccentric with screws	excentrique avec vis		
28	927135-0-00	1	tirante	tie rod	tirant		
29	302708-0-01	1	dado	nut	écrou		
30	927134-0-00	1	snodo sferico	knuckle	axe (joint)		
			SOLO A RICHIESTA	ONLY ON REQUEST	SEULEMENT SUR DEMANDE		
11	306241-0-00	1	blocchetto (per passante 10 mm.)	block (for belt loop 10 mm.)	bloc (pour passant 10 mm.)		
	306312-0-00	1	blocchetto (per passante 12 mm.)	block (for belt loop 12 mm.)	bloc (pour passant 12 mm.)		
	306320-0-00	1	blocchetto (per passante 15 mm.)	block (for belt loop 15 mm.)	bloc (pour passant 15 mm.)		
	306340-0-00	1	blocchetto (per passante 18 mm.)	block (for belt loop 18 mm.)	bloc (pour passant 18 mm.)		
31	729013-2-00	2	vite	screw	vis		





Fig. N. Abb. N.	Part. N. Piece N. Bestell N. Pieza N.	Ct. Anzahl	DESCRIZIONE	DESCRIPTION	DESCRIPTION	BENENNUNG	DESCRIPCION
1	927197-2-00	1	carter scarica ritagli sinistro	cover	carter		
2	927246-2-00	1	carter	cover	carter		
3	704232-2-00	2	rondella	washer	rondelle		
4	722484-2-00	2	vite	screw	vis		
5	927198-2-00	1	carter scarica ritagli destro.	cover	carter		
6	741936-2-00	4	vite	screw	vis		
7	927137-0-00	1	carterino	cover	carter		
8	303045-0-10	2	vite	screw	vis		
9	744636-2-00	3	vite	screw	vis		
10	927190-0-00	1	carter anteriore	rear cover	carter arrière		

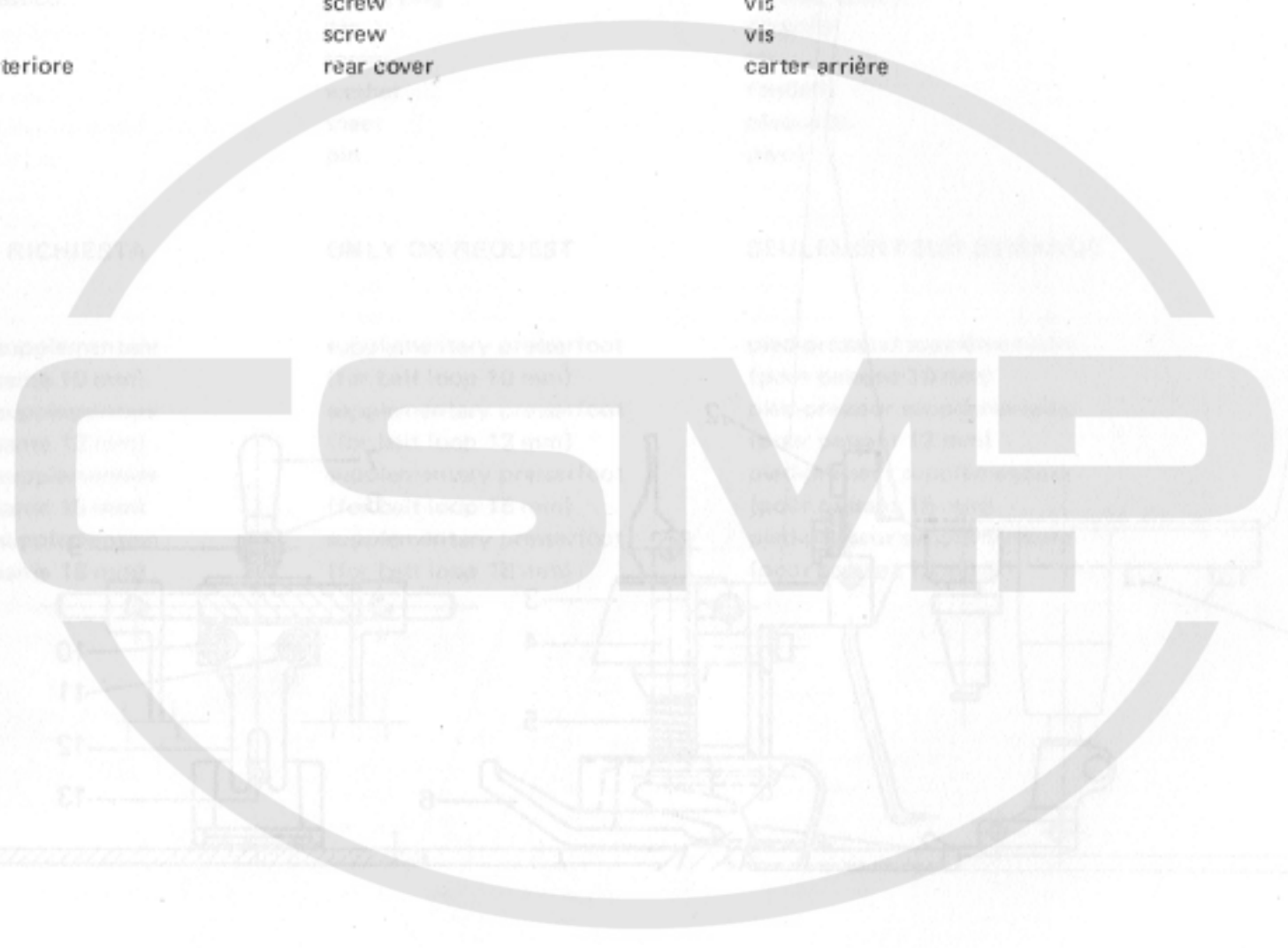

DESCRIPTION

BEWEHRUNG

DESCRIPTION

DESCRIPTION

DESCRIPTION

QTY	Part No.	Part Name	Part No.
1	821107-000	COVER	1
1	821246-000	COVER	2
3	704223-000	WASHER	3
2	732484-000	WASHER	4
1	821108-000	COVER	5
4	741828-000	WASHER	6
1	821131-000	COVER	7
2	302048-010	WASHER	8
2	741829-000	WASHER	9
1	821109-000	COVER	10

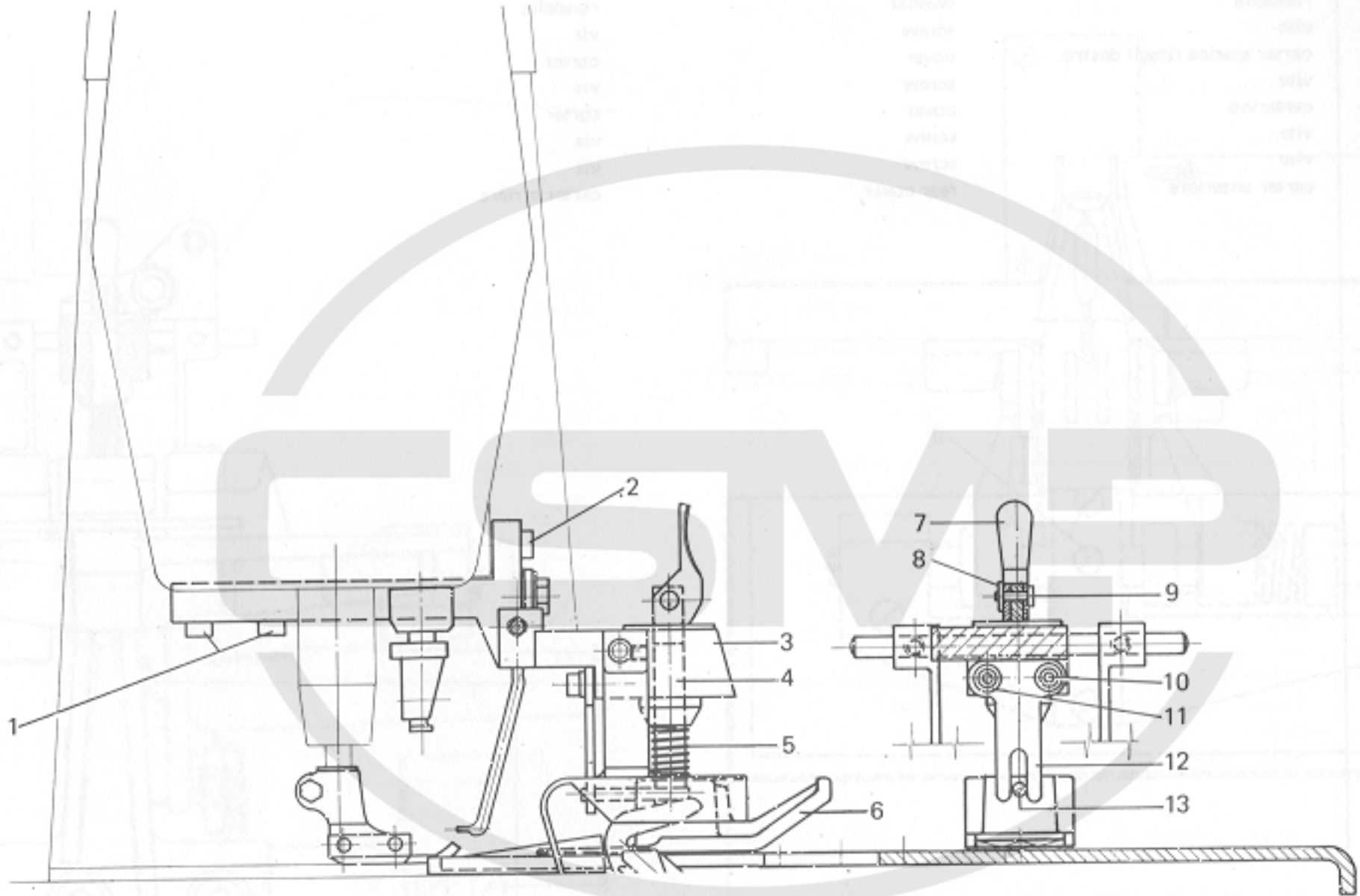

Fig. N. Abb. N.	Part. N. Piece N. Bestell N. Pieza N.	N. N. N. N.	Qt. Anzahl	DESCRIZIONE	DESCRIPTION	DESCRIPTION	BENENNUNG	DESCRIPTION
1	722432-2-00		2	vite	screw	vis		
2	722421-2-00		1	vite	screw	vis		
3	927144-2-00		1	supporto	support	support		
4	927145-0-00		1	perno	pin	pivot		
5	101409-0-10		1	molla	spring	ressort		
6	927155-0-00		1	piedino supp.(per passante 8 mm)	presserfoot (for belt loop 8 mm)	pied-presseur (pour passant 8 mm)		
7	202120-0-10		1	leva	lever	levier		
8	700205-0-00		1	anello elastico	spring ring	anneau ressort		
9	202100-0-10		1	spina	pin	goupille		
10	722411-2-00		2	vite	screw	vis		
11	704306-2-00		2	rondella	washer	rondelle		
12	927147-0-00		1	piastrina	sheet	plaquette		
13	927151-0-00		1	perno	pin	pivot		
14	740034-2-00		1	<b>SOLO A RICHIESTA</b>	<b>ONLY ON REQUEST</b>	<b>SEULEMENT SUR DEMANDE</b>		
15	740034-2-00		1	vite	screw	vis		
16	740034-2-00		1	vite	screw	vis		
6	927156-0-00		1	piedino supplementare (per passante 10 mm)	supplementary presserfoot (for belt loop 10 mm)	pied-presseur supplémentaire (pour passant 10 mm)		
17	927157-0-00		1	piedino supplementare (per passante 12 mm)	supplementary presserfoot (for belt loop 12 mm)	pied-presseur supplémentaire (pour passant 12 mm)		
18	927158-0-00		1	piedino supplementare (per passante 15 mm)	supplementary presserfoot (for belt loop 15 mm)	pied-presseur supplémentaire (pour passant 15 mm)		
19	927159-0-00		1	piedino supplementare (per passante 18 mm)	supplementary presserfoot (for belt loop 18 mm)	pied-presseur supplémentaire (pour passant 18 mm)		



Fig. N. Sub. N.	Part N. Type N. Wavel. N. Place	DESCRIPTION	DESCRIPTION	DESCRIPTION	DESCRIPTION
1	923182-0-00	vis	vis	vis	vis
2	923182-0-00	vis	vis	vis	vis
3	923144-0-00	support	support	support	support
4	923148-0-00	pin	pin	pin	pin
5	101400-0-10	spring	spring	spring	spring
6	923188-0-00	plafond sup. (for passage 8 mm)	plafond sup. (for passage 8 mm)	plafond sup. (for passage 8 mm)	plafond sup. (for passage 8 mm)
7	923188-0-10	levé	levé	levé	levé
8	700202-0-00	axille elastic	axille elastic	axille elastic	axille elastic
9	923100-0-10	pin	pin	pin	pin
10	923181-0-00	vis	vis	vis	vis
11	700202-0-00	axille elastic	axille elastic	axille elastic	axille elastic
12	923181-0-00	vis	vis	vis	vis
13	923181-0-00	vis	vis	vis	vis
14	923181-0-00	vis	vis	vis	vis
15	923181-0-00	vis	vis	vis	vis
16	923181-0-00	vis	vis	vis	vis
17	923181-0-00	vis	vis	vis	vis
18	923181-0-00	vis	vis	vis	vis
19	923181-0-00	vis	vis	vis	vis
20	923181-0-00	vis	vis	vis	vis
21	923181-0-00	vis	vis	vis	vis
22	923181-0-00	vis	vis	vis	vis
23	923181-0-00	vis	vis	vis	vis
24	923181-0-00	vis	vis	vis	vis
25	923181-0-00	vis	vis	vis	vis
26	923181-0-00	vis	vis	vis	vis
27	923181-0-00	vis	vis	vis	vis
28	923181-0-00	vis	vis	vis	vis
29	923181-0-00	vis	vis	vis	vis
30	923181-0-00	vis	vis	vis	vis
31	923181-0-00	vis	vis	vis	vis
32	923181-0-00	vis	vis	vis	vis
33	923181-0-00	vis	vis	vis	vis
34	923181-0-00	vis	vis	vis	vis

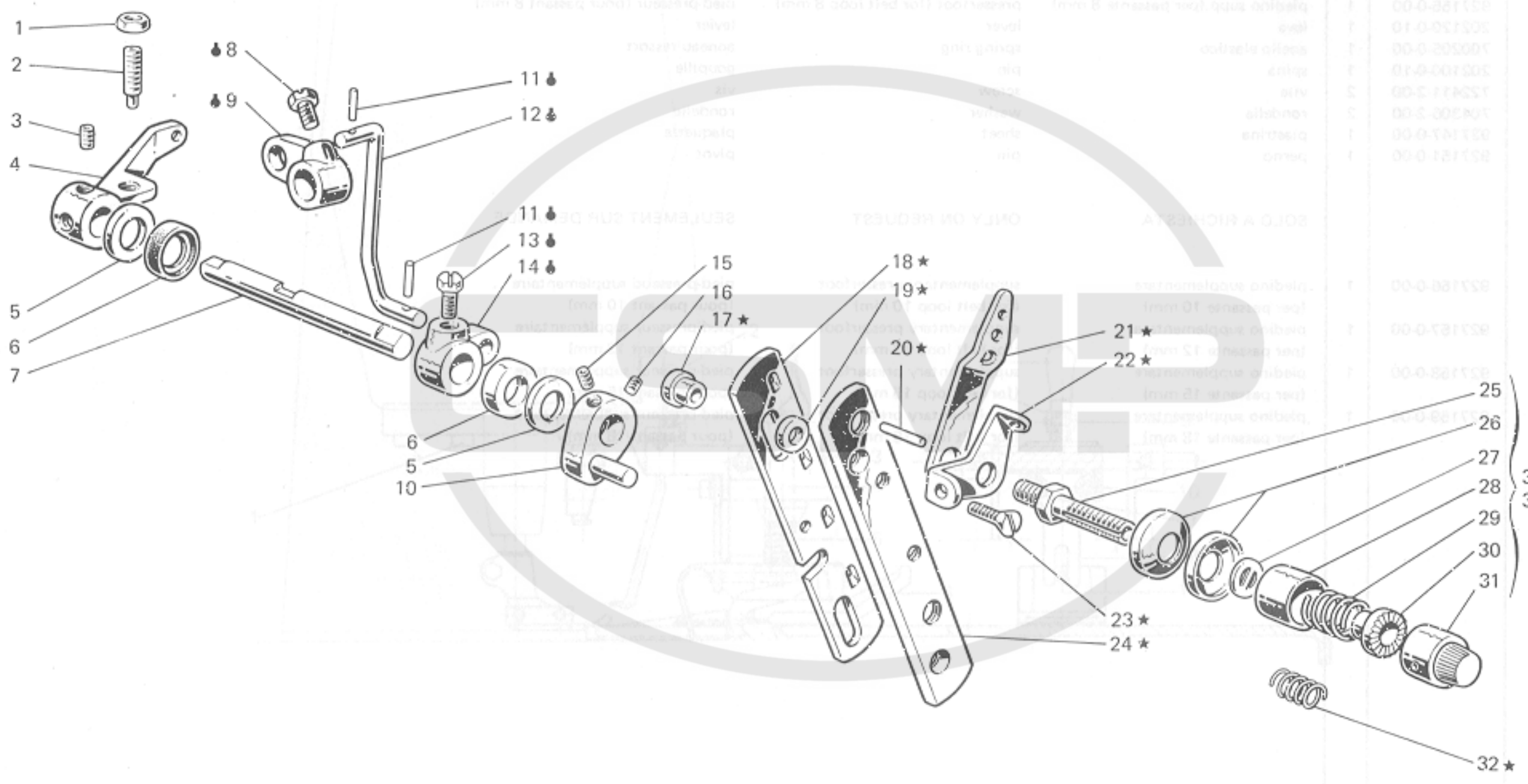
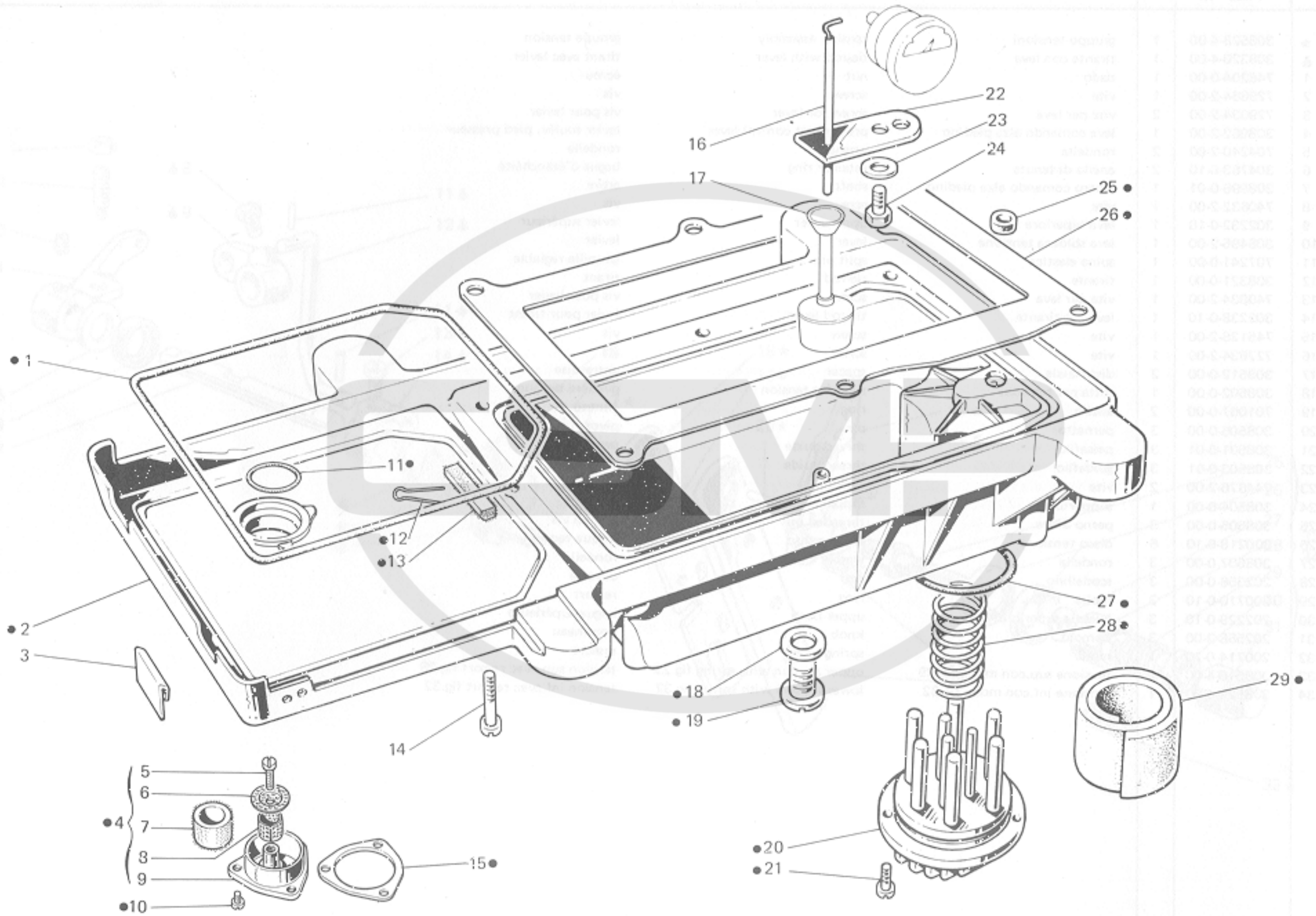

Fig. N. Abb. N.	Part. N. Bestell N. Piece N. Pieza N.	Qt. Anzahl	DESCRIZIONE	DESCRIPTION	DESCRIPTION	BENENNUNG	DESCRIPCION
★	308528-4-00	1	gruppo tensioni	tension assembly		groupe tension	
●	308320-4-00	1	tirante con leva	tie-rod with lever		tirant avec levier	
1	746204-0-00	1	dado	nut		écrou	
2	729884-2-00	1	vite	screw		vis	
3	729034-2-00	2	vite per leva	screw for lever		vis pour levier	
4	308062-2-00	1	leva comando alza piedino	presserfoot control lever		levier soulèv. pied presseur	
5	704240-2-00	2	rondella	washer		rondelle	
6	304763-0-10	2	anello di tenuta	retainer ring		bagua d'étanchéité	
7	308996-0-01	1	albero comando alza piedino	shaft		arbre	
8	740632-2-00	1	vite	screw		vis	
9	302232-0-10	1	leva superiore	upper lever		levier supérieur	
10	308495-2-00	1	leva sblocca tensione	lever		levier	
11	707241-0-00	1	spina elastica	split pin		goupille réglable	
12	308321-0-00	1	tirante	tie-rod		tirant	
13	740034-2-00	1	vite per leva	screw		vis pour levier	
14	302238-0-10	1	leva per tirante	tie-rod lever		levier pour tirant	
15	745126-2-00	1	vite	screw		vis	
16	727834-2-00	1	vite	screw		vis	
17	308512-0-00	2	distanziale	spacer		entretoise	
18	308502-0-00	1	slitta per tensione	slide for tension		glissière tension	
19	701007-0-00	2	anello	ring		anneau	
20	308506-0-00	3	pernetto	pin		pivot	
21	308501-0-01	3	passafilo	thread guide		passe-fil	
22	308503-0-01	3	guidafilo	thread guide		guide fil	
23	744676-2-00	2	vite	screw		vis	
24	308504-0-00	1	supporto	support		support	
25	308505-0-00	3	perno a vite	threaded pin		pivot à vis	
26	300218-0-10	6	disco tensione	tension disc		disque tension	
27	308507-0-00	3	rondella	washer		rondelle	
28	202556-0-00	3	scodellino	cup		cuvette	
29	200710-0-10	2	molla	ring		ressort	
30	202229-0-10	3	bussola superiore	upper bush		bague supérieure	
31	202558-2-00	3	pomolo	knob		pommeau	
32	200714-0-10	1	molla	spring		ressort	
33	308518-4-00	2	tensione sup.con molla fig.29	upper tension with spring fig.29		tension sup.avec ressort fig.29	
34	308521-4-00	1	tensione inf.con molla fig.32	lower tension with spring fig.32		tension inf.avec ressort fig.32	



DESCRIPTION

BEZEICHNUNG

DESCRIPTION

DESCRIPTION

DESCRIZIONE

Part No.	Part No.	Part No.	Part No.
Accessories	Accessories	Accessories	Accessories
1	2	3	4
5	6	7	8
9	10	11	12
13	14	15	16
17	18	19	20
21	22	23	24
25	26	27	28
29	30	31	32

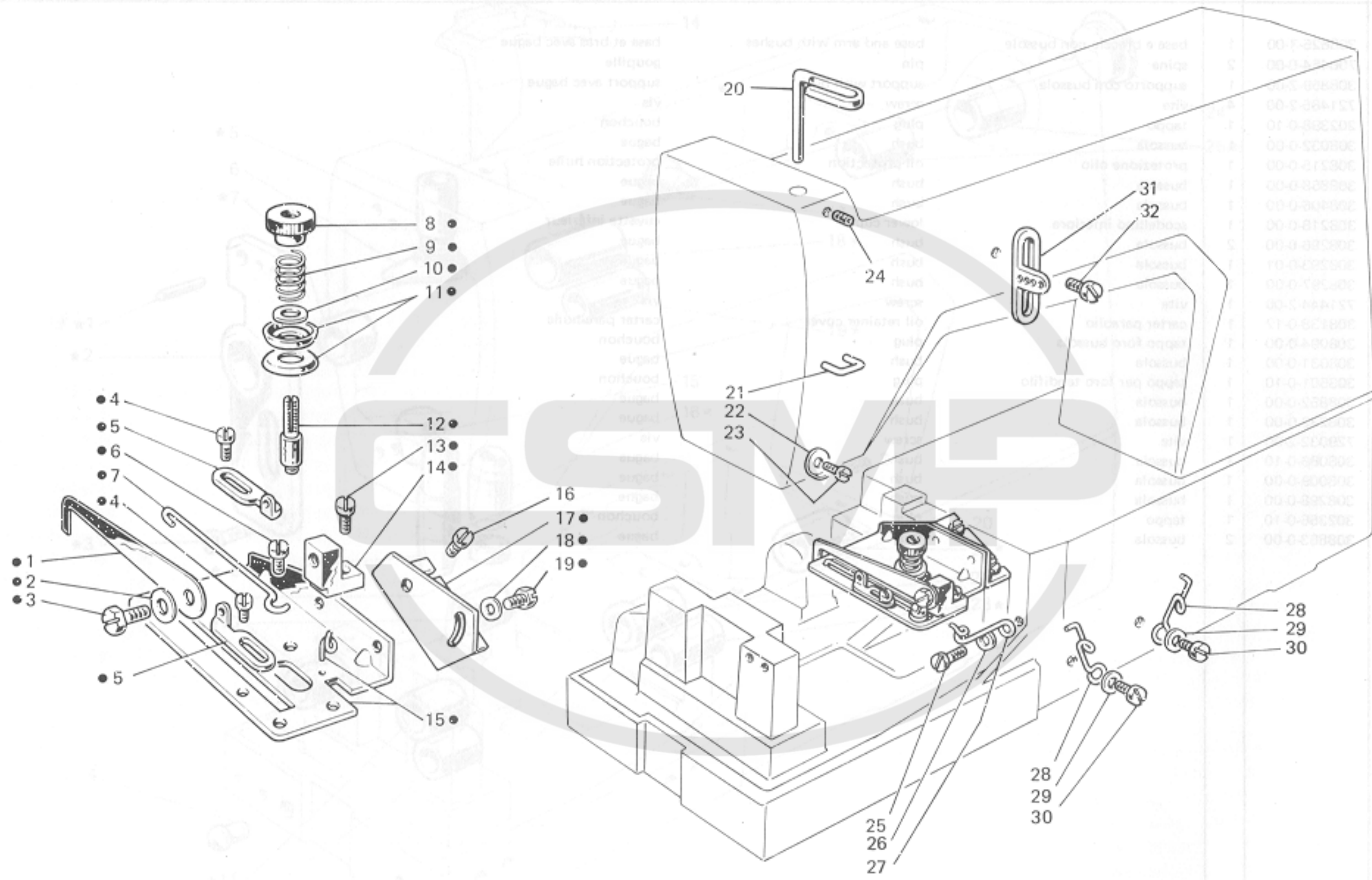
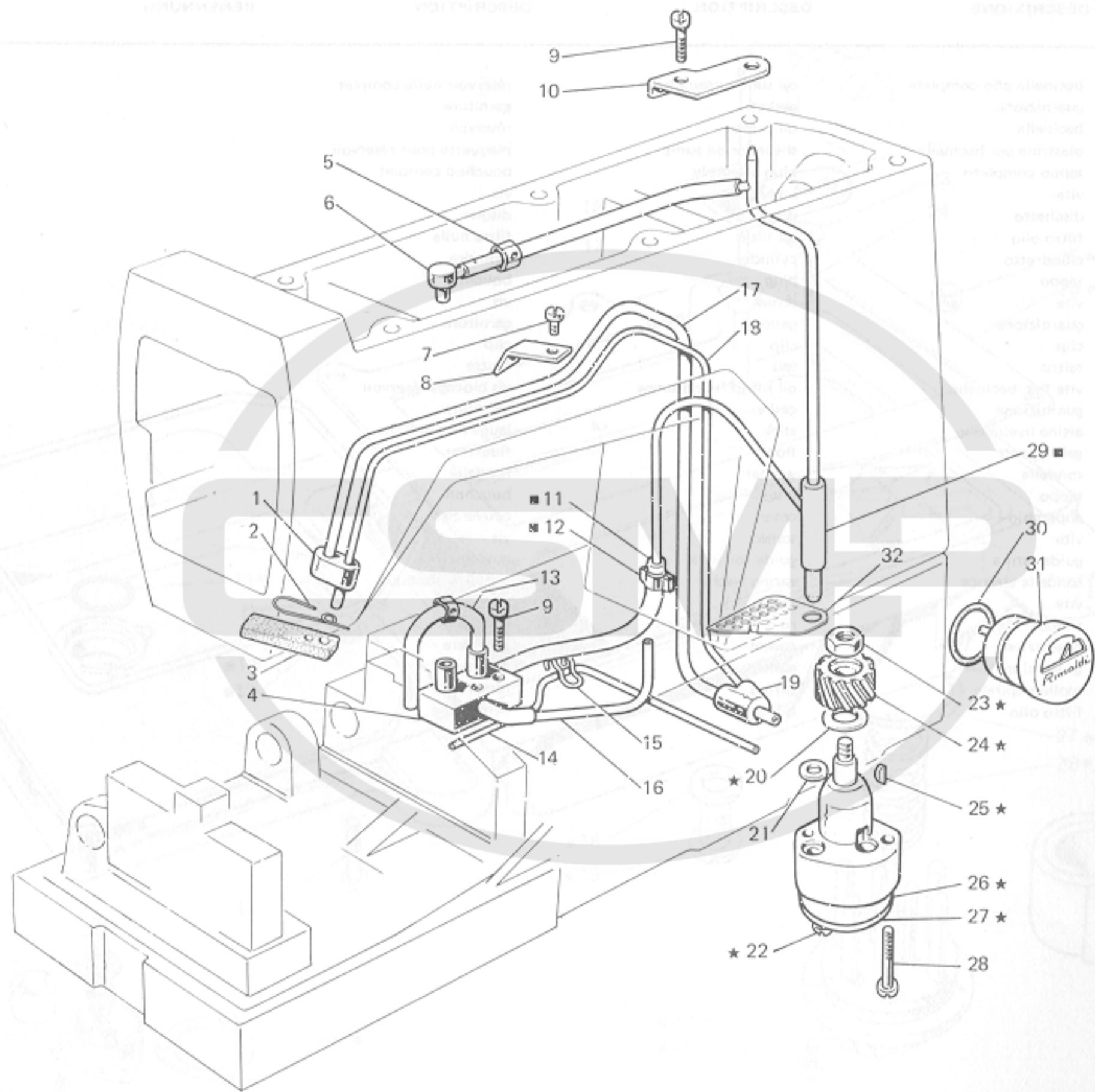

Fig. N. Abb. N.	Part. N. Piece N. Bestell N. Pieza N.	Qt. Anzahl	DESCRIZIONE	DESCRIPTION	DESCRIPTION	BENENNUNG	DESCRIPCION
●	308592-4-10	1	bacinella olio completa	oil sump assembly	réservoir huile complet		
1	308125-0-01	1	guarnizione	gasket	garniture		
2	308580-2-20	1	bacinella	oil sump	réservoir		
3	308002-0-00	2	piastrina per bacinella	sheet for oil sump	plaquette pour réservoir		
4	308331-4-00	1	tappo completo	plug assembly	bouchon complet		
5	721484-2-00	1	vite	screw	vis		
6	308209-0-00	1	dischetto	disc	disque		
7	308206-0-00	1	filtro olio	oil filter	filtre huile		
8	308210-0-00	1	cilindretto	cylinder	cylindre		
9	308208-0-00	1	tappo	plug	bouchon		
10	722411-2-00	3	vite	screw	vis		
11	701134-0-00	1	guarnizione	gasket	garniture		
12	308957-0-00	1	clip	clip	clip		
13	308213-0-00	1	feltro	felt	feutre		
14	722453-2-00	6	vite fiss. bacinella	oil sump fixing screw	vis blocage réservoir		
15	308179-0-00	1	guarnizione	gasket	garniture		
16	308379-0-00	1	astina livello olio	stick	jauge niveau huile		
17	206665-2-00	1	galleggiante	float	floateur		
18	705977-0-00	1	rondella	washer	rondelle		
19	206564-0-00	1	tappo	plug	bouchon		
20	206560-0-10	1	coperchio	cover	couvercle		
21	722063-2-00	2	vite	screw	vis		
22	308226-0-02	1	guida astina	guide for stick	guide barre		
23	703003-0-00	1	rondella elastica	spring washer	rondelle élastique		
24	740240-0-00	1	vite	screw	vis		
25	308113-0-00	1	anello	ring	anneau		
26	311395-0-00	1	guarnizione	gasket	garniture		
27	701051-0-00	1	guarnizione	gasket	garniture		
28	206545-0-00	1	molla a spirale	spring	ressort		
29	206559-0-01	1	filtro olio	oil filter	filtre huile		
30	308190-2-01	1	racorda mandato	oil sump assembly			
31	701134-0-00	1	guarnizione	gasket			
32	308580-2-20	1	bacinella	oil sump			





Q.T.	Descrizione	Part. No.	Part. No.
1		30852-0-10	*
1		30852-0-01	1
2		30850-0-20	2
2		30802-0-90	3
1		30831-4-00	4
1		30844-0-00	5
1		30809-0-00	6
1		30808-0-00	7
1		30810-0-00	8
1		30808-0-00	9
1		30811-0-00	10
1		30813-0-00	11
1		30813-0-00	12
1		30813-0-00	13
1		30813-0-00	14
1		30813-0-00	15
1		30813-0-00	16
1		30813-0-00	17
1		30813-0-00	18
1		30813-0-00	19
1		30813-0-00	20
1		30813-0-00	21
1		30813-0-00	22
1		30813-0-00	23
1		30813-0-00	24
1		30813-0-00	25
1		30813-0-00	26
1		30813-0-00	27
1		30813-0-00	28
1		30813-0-00	29
1		30813-0-00	30
1		30813-0-00	31
1		30813-0-00	32

Fig. N. Abb. N.	Part. N. Piece N. Bestell N. Pieza N.	Qt. Anzahl	DESCRIZIONE	DESCRIPTION	DESCRIPTION	BENENNUNG	DESCRIPTION
★	308105-4-03	1	pompa olio completa	oil pump assembly	pompe à huile complet		
■	310500-4-00	1	raccordo mandata olio compl.	pipe connection oil delivery ass.	raccord envoi huile compl.		
1	308123-0-00	1	raccordo superiore	upper pipe connection	raccord supérieur		
2	307990-0-00	1	molletta	spring	ressort		
3	307991-0-00	1	feltro	felt	feutre		
4	308114-2-02	1	distributore	distributor	distributeur		
5	308040-2-00	1	tubetto	pipe	tube		
6	308214-0-00	1	raccordo mandata olio	pipe connection oil delivery	raccord envoi huile		
7	721424-2-00	1	vite	screw	vis		
8	308184-0-00	1	fascetta	clamp	bride		
9	721514-0-00	3	vite	screw	vis		
10	308104-0-00	1	piastrina	plate	plaque		
11	308207-0-00	1	tubetto	pipe	tube		
12	308043-0-00	1	fascetta	clamp	bride		
13	310561-2-00	1	tubetto	pipe	tube		
14	790325-0-00	1	tubetto	pipe	tube		
15	308211-0-00	2	clip	clip	clip		
16	790315-0-00	1	tubetto	pipe	tube		
17	790342-0-00	1	tubetto recupero olio	pipe	tube		
18	790242-0-00	1	tubetto recupero olio	pipe	tube		
19	308185-0-00	1	raccordo inferiore	lower pipe connection	raccord inférieur		
20	704813-0-00	1	rondella	washer	rondelle		
21	701004-0-00	1	anello di tenuta	retainer ring	bague d'étanchéité		
22	741082-2-00	2	vite	screw	vis		
23	733507-0-00	1	dado	nut	écrou		
24	206555-0-00	1	ingranaggio	gear	engrenage		
25	206557-0-00	1	chiavetta	key	clé		
26	308110-3-00	1	corpo pompa aspirante	suction pump body	corps pompe admission		
27	308111-0-00	1	coperchio pompa	pump cover	couvercle pompe		
28	741092-0-00	2	vite fissaggio pompa	screw	vis		
29	308180-2-01	1	raccordo mandata olio	pipe connection oil delivery	raccord envoi huile		
30	701032-0-00	1	anello di tenuta	circlip	circlip		
31	206669-2-02	1	indicatore livello olio	oil level gauge	indicateur niveau huile		
32	305656-0-00	1	lamierino di protezione	sheet	plaque		

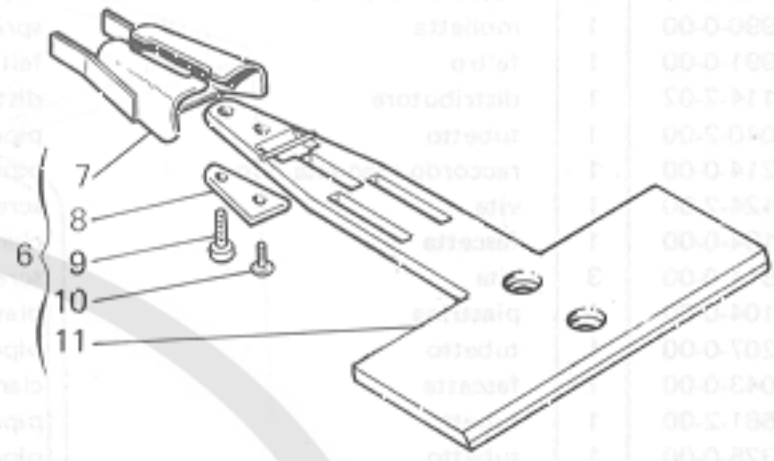
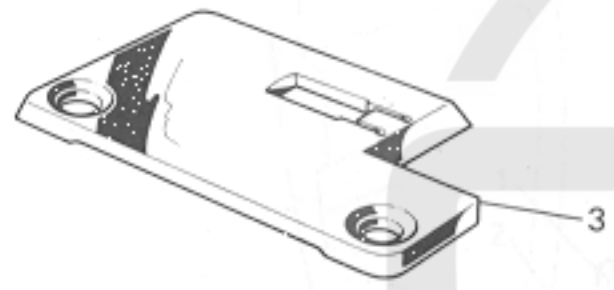
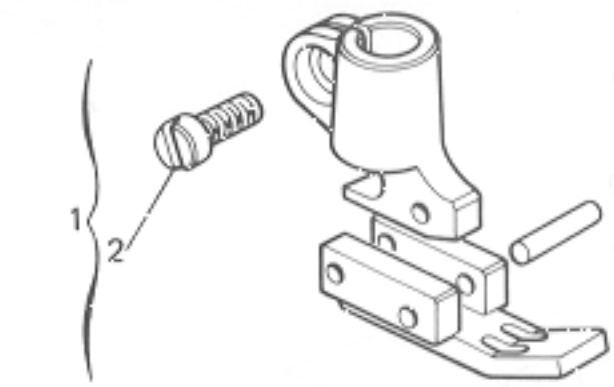

Q.TA.	DESCRIZIONE	DESCRIZIONE	DESCRIZIONE	DESCRIZIONE	Q.TA.	DESCRIZIONE
1	308102-4-03	1	308102-4-03	1	308102-4-03	1
1	310500-4-00	1	310500-4-00	1	310500-4-00	1
1	308123-0-00	1	308123-0-00	1	308123-0-00	1
3	307980-0-00	3	307980-0-00	3	307980-0-00	3
3	307991-0-00	3	307991-0-00	3	307991-0-00	3
4	308114-2-03	4	308114-2-03	4	308114-2-03	4
5	308040-2-00	5	308040-2-00	5	308040-2-00	5
1	308214-0-00	1	308214-0-00	1	308214-0-00	1
3	321424-0-00	3	321424-0-00	3	321424-0-00	3
8	308111-0-00	8	308111-0-00	8	308111-0-00	8
9	321111-0-00	9	321111-0-00	9	321111-0-00	9
10	308104-0-00	10	308104-0-00	10	308104-0-00	10
11	308207-0-00	11	308207-0-00	11	308207-0-00	11
12	308043-0-00	12	308043-0-00	12	308043-0-00	12
13	310501-2-00	13	310501-2-00	13	310501-2-00	13
14	180128-0-00	14	180128-0-00	14	180128-0-00	14
18	308211-0-00	18	308211-0-00	18	308211-0-00	18
18	180215-0-00	18	180215-0-00	18	180215-0-00	18
13	180242-0-00	13	180242-0-00	13	180242-0-00	13
18	180242-0-00	18	180242-0-00	18	180242-0-00	18
12	308128-0-00	12	308128-0-00	12	308128-0-00	12
1	308123-0-00	1	308123-0-00	1	308123-0-00	1
1	308123-0-00	1	308123-0-00	1	308123-0-00	1
2	308104-0-00	2	308104-0-00	2	308104-0-00	2
1	308104-0-00	1	308104-0-00	1	308104-0-00	1
1	308110-2-00	1	308110-2-00	1	308110-2-00	1
1	308111-0-00	1	308111-0-00	1	308111-0-00	1
2	308103-0-00	2	308103-0-00	2	308103-0-00	2
1	308180-2-01	1	308180-2-01	1	308180-2-01	1
1	308103-0-00	1	308103-0-00	1	308103-0-00	1
1	308088-2-02	1	308088-2-02	1	308088-2-02	1
1	308088-0-00	1	308088-0-00	1	308088-0-00	1

Fig. N. Abb. N.	Pert. N. Piece N. Bestell N. Pieza N.	Qt. Anzahl	DESCRIZIONE	DESCRIPTION	DESCRIPTION	BENENNUNG	DESCRIPTION
1	306308-3-01	1	piedino completo (per passante 8 mm)	presserfoot assembly (for belt loop 8 mm)	pied-presseur complet (pour passant 8 mm)		
2	741721-2-00	1	vite	screw	vis		
3	306306-0-00	1	piacca ago	needle plate	plaque à aiguille		
4	306203-0-11	1	griffa principale	main feed dog	griffe principale		
5	306218-0-00	1	griffa supplementare	supplementary feed dog	griffe supplémentaire		
6	927174-4-00	1	placca supplementare (per passante 8 mm)	supplementary plate (for belt loop 8 mm)	plaque supplémentaire (pour passant 8 mm)		
7	306880-2-00	1	guida (per passante 8 mm)	guide (for belt loop 8 mm)	guide (for belt loop 8 mm)		
8	306274-0-00	1	blocchetto (per passante 8-10-12 mm)	block (for belt loop 8-10-12 mm)	bioc (pour passant 8-10-12 mm)		
9	741453-0-00	1	vite	screw	vis		
10	744530-0-00	1	vite	screw	vis		
11	927168-4-00	1	placca supplementare (per passante 8 mm)	supplementary plate (for belt loop 8 mm)	plaque supplémentaire (pour passant 8 mm)		
12	302057-0-13	1	crochet inferiore	lower looper	crochet inférieur		
13	784392-0-40	1	targhetta classe testa	head class plate	plaque classe tête		
			<b>SOLO A RICHIESTA</b>	<b>ONLY ON REQUEST</b>	<b>SEULEMENT SUR DEMANDE</b>		
1	306277-3-01	1	piedino completo (per passante 10 mm.)	presserfoot assembly (for belt loop 10 mm.)	pied-presseur complet (pour passant 10 mm.)		
	306319-3-01	1	piedino completo (per passante 12 mm.)	presserfoot assembly (for belt loop 12 mm.)	pied-presseur complet (pour passant 12 mm.)		
	306327-3-01	1	piedino completo (per passante 15 mm.)	presserfoot assembly (for belt loop 15 mm.)	pied-presseur complet (pour passant 15 mm.)		
	306367-3-01	1	piedino completo (per passante 18 mm.)	presserfoot assembly (for belt loop 18 mm.)	pied-presseur complet (pour passant 18 mm.)		
6	927175-4-00	1	placca supplementare (per passante 10 mm.)	supplementary plate (for belt loop 10 mm.)	plaque supplémentaire (pour passant 10 mm.)		
	927176-4-00	1	placca supplementare (per passante 12 mm.)	supplementary plate (for belt loop 12 mm.)	plaque supplémentaire (pour passant 12 mm.)		
	927177-4-00	1	placca supplementare (per passante 15 mm.)	supplementary plate (for belt loop 15 mm.)	plaque supplémentaire (pour passant 15 mm.)		
	927178-4-00	1	placca supplementare (per passante 18 mm.)	supplementary plate (for belt loop 18 mm.)	plaque supplémentaire (pour passant 18 mm.)		
7	306881-2-00	1	guida (per passante 10 mm.)	guide (for belt loop 10 mm.)	guide (pour passant 10 mm.)		
	306882-2-00	1	guida (per passante 12 mm.)	guide (for belt loop 12 mm.)	guide (pour passant 12 mm.)		
	306883-2-00	1	guida (per passante 15 mm.)	guide (for belt loop 15 mm.)	guide (pour passant 15 mm.)		
	306884-2-00	1	guida (per passante 18 mm.)	guide (for belt loop 18 mm.)	guide (pour passant 18 mm.)		
8	306275-0-00	1	blocchetto (per passante 15-18 mm.)	block (for belt loop 15-18 mm.)	bloc (pour passant 15-18 mm.)		
11	927169-4-00	1	placca supplementare (per passante 10 mm.)	supplementary plate (for belt loop 10 mm.)	plaque supplémentaire (pour passant 10 mm.)		
	927170-4-00	1	placca supplementare (per passante 12 mm.)	supplementary plate (for belt loop 12 mm.)	plaque supplémentaire (pour passant 12 mm.)		
	927171-4-00	1	placca supplementare (per passante 15 mm.)	supplementary plate (for belt loop 15 mm.)	plaque supplémentaire (pour passant 15 mm.)		
	927172-4-00	1	placca supplementare (per passante 18 mm.)	supplementary plate (for belt loop 18 mm.)	plaque supplémentaire (pour passant 18 mm.)		

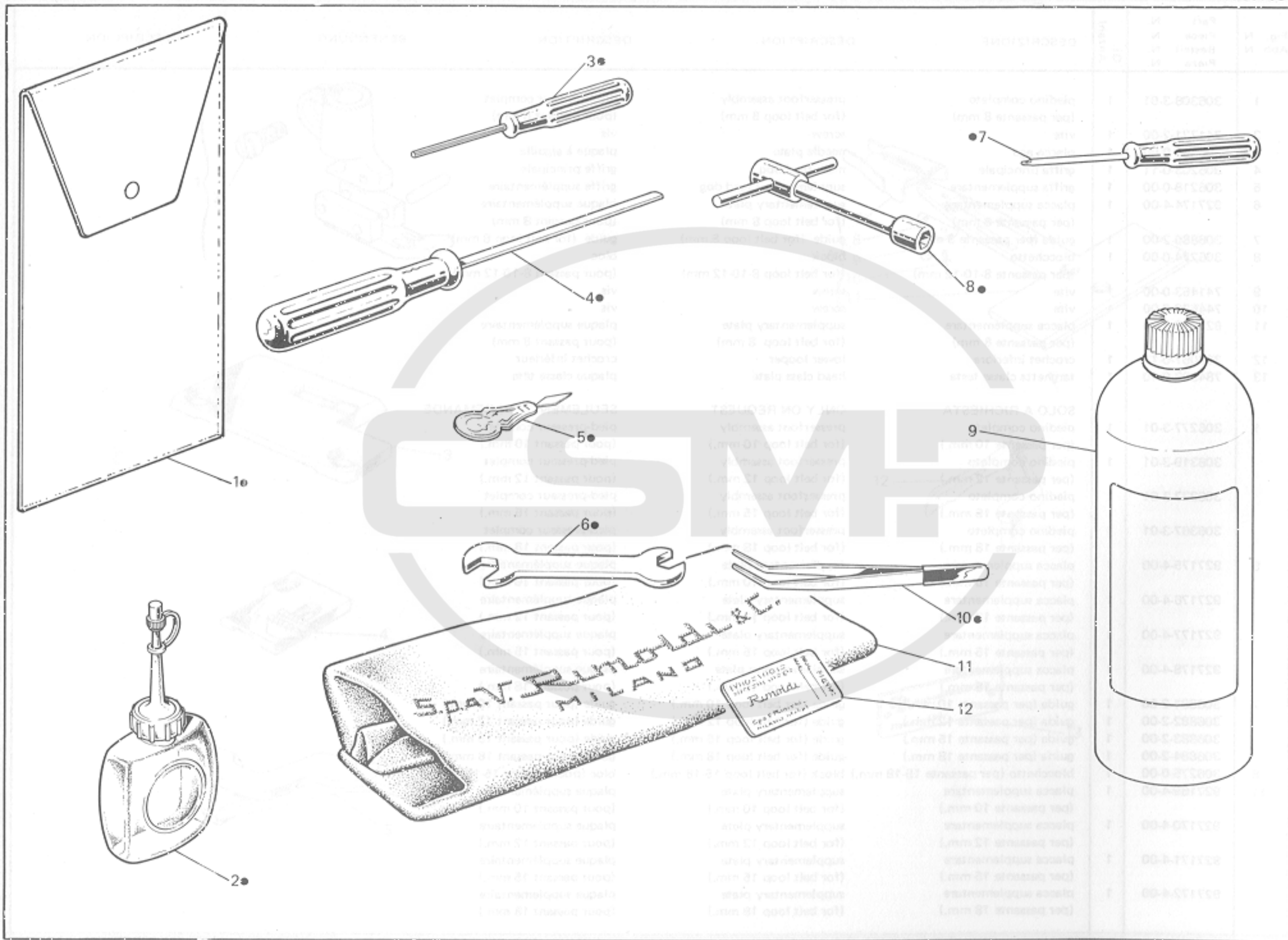

Fig. N. Abb. N.	Part. N. Piecce N. Bestell N. Pieza N.	Qt. Anzahl	DESCRIZIONE	DESCRIPTION	DESCRIPTION	BENENNUNG	DESCRIPCION
●	991408-4-02	1	busta accessori completa	accessories envelope assembly	envelope accessoires complète		
1	991415-0-00	1	busta accessori	accessories envelope	envelope accessoires		
2	990175-0-10	1	oliatore	olier	graisseur		
3	990474-0-11	1	chiave esagonale da 1,5 mm	1,5 mm hexagonal key	clé hexagonale de 1,5 mm		
4	990723-0-00	1	cacciavite medio	screw-driver	tournevis moyen		
5	990188-0-10	1	infilatura aghi	needle threading	enfile aiguille		
6	990193-0-00	1	chiave da 5-7 mm	5-7 mm key	clé de 5-7 mm		
7	990069-0-00	1	cacciavite piccolo	screw driver	petite tournevis		
8	990587-0-11	1	chiave a tubo da 9 mm	9 mm key	clé à tube de 9 mm		
9	991280-0-00	1	lattina olio	oil container	bidon huile		
10	990176-0-10	1	pinza per infilatura	threading tweezers	pince pour enfilage		
11	990578-0-13	1	cuffia protez. macchina	machine cover	couverture protection machine		
12	★	1	bustina aghi	needle packet	paquette aiguille		
			★ per l'ordinazione della bustina citare lo stesso simbolo dell'ago montato sulla testa	★ to order packet of needle please specify symbol of needle fitted on machine	★ pour commander un sachet d'aiguille donner le symbole de l'aiguille montée sur la tête		

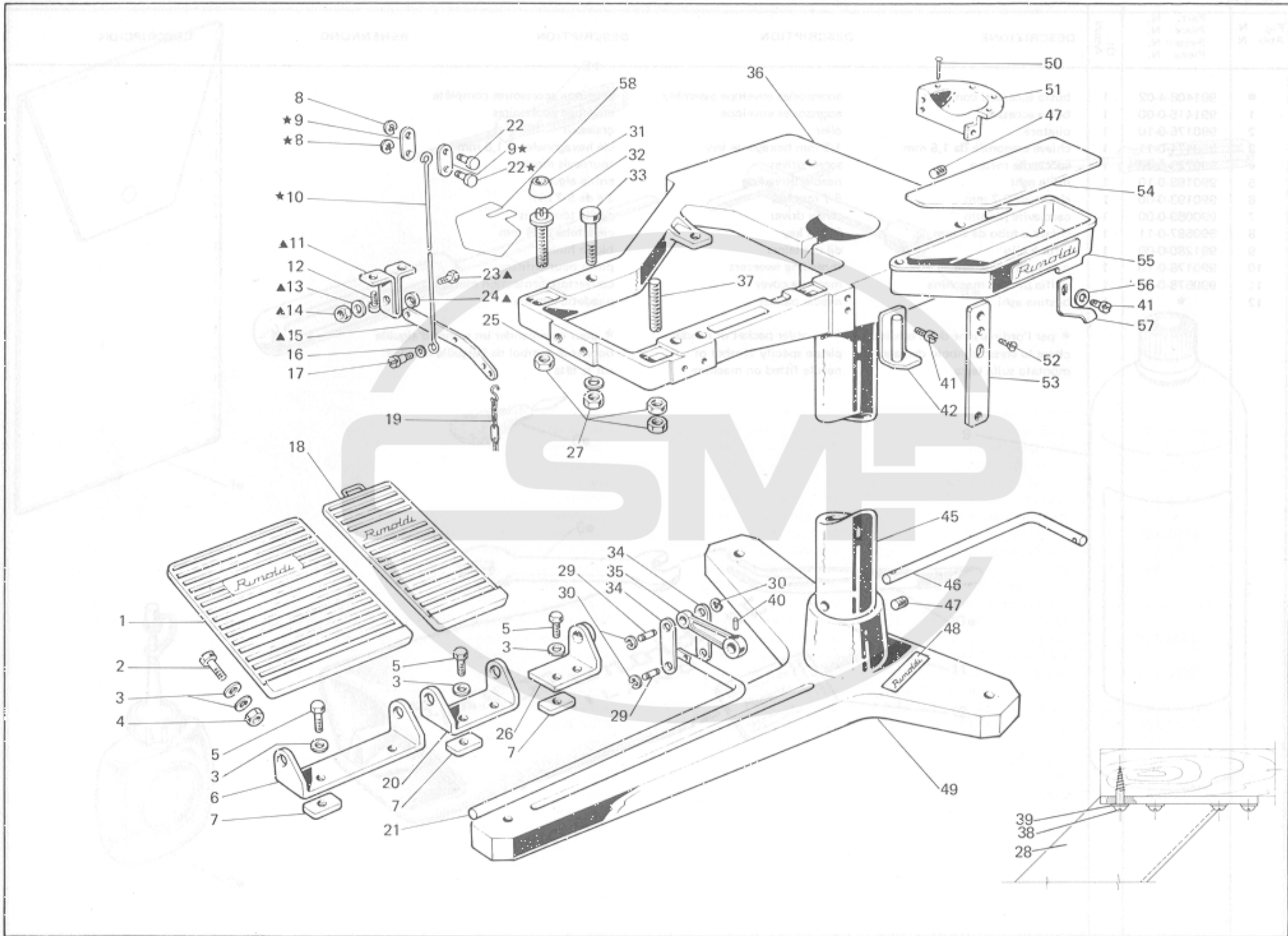

Fig. N. Abb. N.	Part. N. Piece N. Bestell N. Pieza N.	Qt. Anzahl	DESCRIZIONE	DESCRIPTION	DESCRIPTION	BENENNUNG	DESCRIPCION
42	900709-0-10	1	PIAZZAMENTO BANCALE A COLONNA (con canale scarica ritagli)	COLUMN STAND SETTING (with offlet)	INSTALLATION BATI A COLONNE (avec canal décharge-chutes)		
★	990797-4-00	1	tirante alza piedino compl.	presser tie-rod assembly	tirante pour soulèv. de biche compl.		
▲	990644-4-10	1	cavallotto con leva compl.	coupling with lever assembly	cavalier avec levier compl.		
1	900734-3-10	1	pedalina completa	pedal assembly	pédale complète		
2	722493-2-00	4	vite	screw	vis		
3	704226-2-00	16	rondella	washer	rondelle		
4	746203-4-00	4	dado	nut	écrou		
5	720494-2-00	6	vite	screw	vis		
6	900738-0-10	1	supporto pedana	pedal support	support pédale		
7	900737-0-10	6	piastrina	plate	plaque		
8	700205-0-00	2	anello elastico	spring ring	anneau ressort		
9	990765-0-00	2	piastrina	plate	plaque		
10	990662-0-11	1	tirante	tie-rod	tirant		
11	990643-0-10	1	cavallotto	coupling	cavalier		
12	721484-2-00	2	vite	screw	vis		
13	704009-0-00	1	rondella	washer	rondelle		
14	748408-2-00	1	dado	nut	écrou		
15	990645-0-11	1	leva	lever	lever		
16	704310-0-00	1	rondella	washer	rondelle		
17	743541-2-00	1	vite	screw	vis		
18	900728-3-10	1	pedalina completa	pedal assembly	pédale complète		
19	990179-4-11	1	catenella completa	chain assembly	chaînette compl.		
20	900731-0-10	1	supporto pedalina	pedal support	support pédale		
21	900760-0-10	1	albero	shaft	arbre		
22	203211-0-10	2	perno	pin	pivot		
23	740888-0-00	1	vite	screw	vis		
24	990648-0-10	1	distanziale	spacer	entretoise		
25	704344-2-00	4	rondella	washer	rondelle		
26	900744-2-00	1	supporto	support	support		
27	733008-2-00	16	dado	nut	écrou		
28	927199-0-00	1	canale scarica ritagli	offlet	canal décharge-chutes		
29	900714-0-10	2	perno	pin	pivot		
30	700208-0-00	4	anello elastico	spring ring	anneau ressort		
31	990982-0-00	4	ammortizzatore	shock absorber	amortisseur		
32	900694-0-11	4	perno	pin	pivot		
33	722905-2-00	4	vite	screw	vis		
34	900715-0-10	2	piastrina	plate	plaque		
35	900713-0-10	1	leva	lever	levier		
36	900750-0-11	1	sostegno testa	head support	support tête		
37	900647-0-10	4	prigioniero	pin	pivot		
38	731107-0-00	7	vite	screw	vis		
39	704316-2-00	7	rondella	washer	rondelle		
40	707298-0-00	1	spina elastica	split pin	goupille filetés		
41	721475-2-00	3	vite	screw	vis		
42	900706-2-10	1	sostegno cassetto	support	support		
45	900709-0-10	1	colonna	column	colonne		



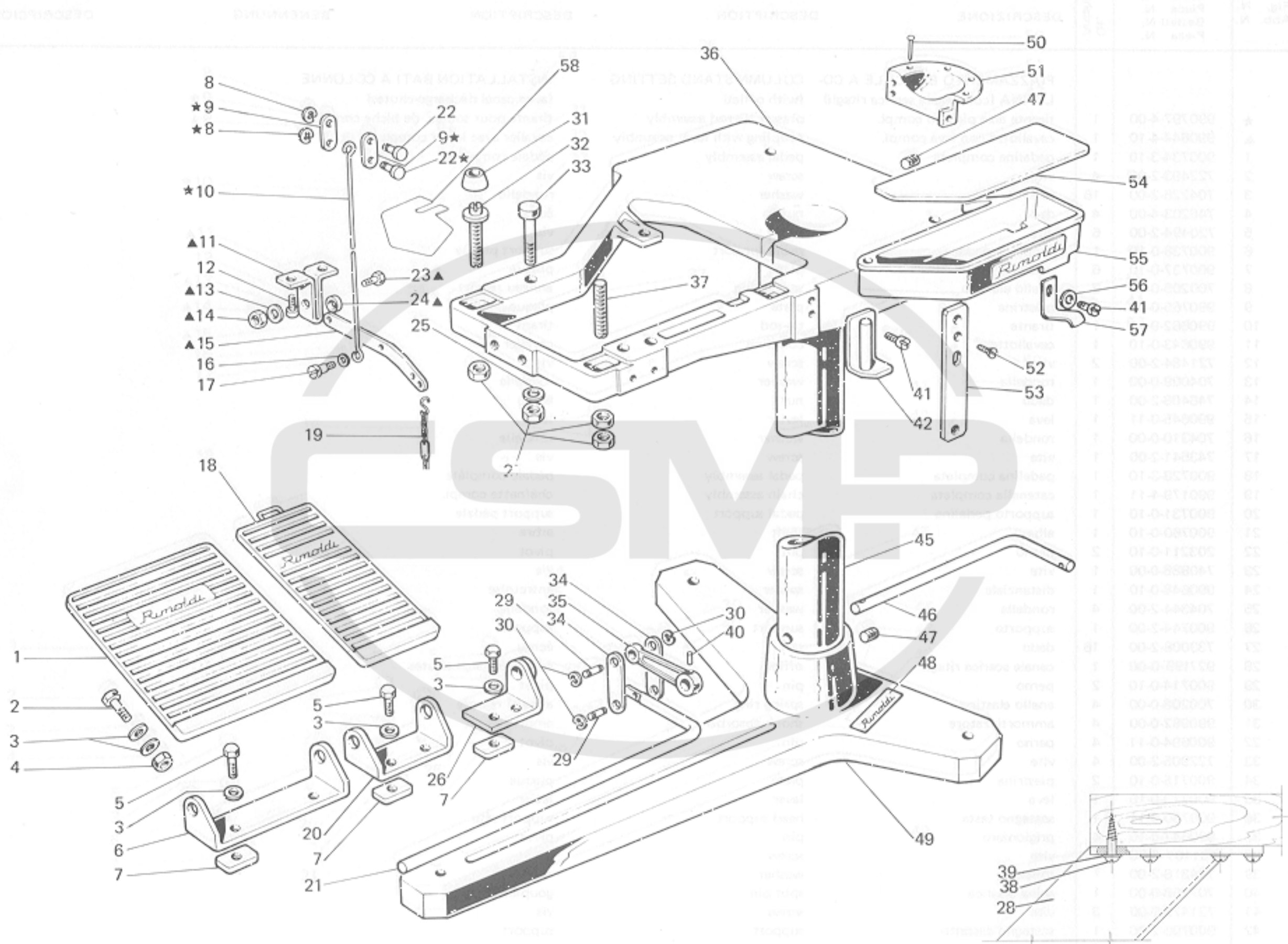

Fig. N°	Descrizione	Q.tà	Part. N°
1	Griglia superiore	1	00128-0-10
2	Griglia inferiore	1	00129-0-10
3	Griglia superiore	1	00130-0-10
4	Griglia inferiore	1	00131-0-10
5	Griglia superiore	1	00132-0-10
6	Griglia inferiore	1	00133-0-10
7	Griglia superiore	1	00134-0-10
8	Griglia inferiore	1	00135-0-10
9	Griglia superiore	1	00136-0-10
10	Griglia inferiore	1	00137-0-10
11	Griglia superiore	1	00138-0-10
12	Griglia inferiore	1	00139-0-10
13	Griglia superiore	1	00140-0-10
14	Griglia inferiore	1	00141-0-10
15	Griglia superiore	1	00142-0-10
16	Griglia inferiore	1	00143-0-10
17	Griglia superiore	1	00144-0-10
18	Griglia inferiore	1	00145-0-10
19	Griglia superiore	1	00146-0-10
20	Griglia inferiore	1	00147-0-10
21	Griglia superiore	1	00148-0-10
22	Griglia inferiore	1	00149-0-10
23	Griglia superiore	1	00150-0-10
24	Griglia inferiore	1	00151-0-10
25	Griglia superiore	1	00152-0-10
26	Griglia inferiore	1	00153-0-10
27	Griglia superiore	1	00154-0-10
28	Griglia inferiore	1	00155-0-10
29	Griglia superiore	1	00156-0-10
30	Griglia inferiore	1	00157-0-10
31	Griglia superiore	1	00158-0-10
32	Griglia inferiore	1	00159-0-10
33	Griglia superiore	1	00160-0-10
34	Griglia inferiore	1	00161-0-10
35	Griglia superiore	1	00162-0-10
36	Griglia inferiore	1	00163-0-10
37	Griglia superiore	1	00164-0-10
38	Griglia inferiore	1	00165-0-10
39	Griglia superiore	1	00166-0-10
40	Griglia inferiore	1	00167-0-10
41	Griglia superiore	1	00168-0-10
42	Griglia inferiore	1	00169-0-10
43	Griglia superiore	1	00170-0-10
44	Griglia inferiore	1	00171-0-10
45	Griglia superiore	1	00172-0-10
46	Griglia inferiore	1	00173-0-10
47	Griglia superiore	1	00174-0-10
48	Griglia inferiore	1	00175-0-10
49	Griglia superiore	1	00176-0-10
50	Griglia inferiore	1	00177-0-10
51	Griglia superiore	1	00178-0-10
52	Griglia inferiore	1	00179-0-10
53	Griglia superiore	1	00180-0-10
54	Griglia inferiore	1	00181-0-10
55	Griglia superiore	1	00182-0-10
56	Griglia inferiore	1	00183-0-10
57	Griglia superiore	1	00184-0-10
58	Griglia inferiore	1	00185-0-10

Fig. N. Abb. N.	Part. N. Bestell N. Piece N. Pieza N.	Qt. Anzahl	DESCRIZIONE	DESCRIPTION	DESCRIPTION	BENENNUNG	DESCRIPCION
●	308934-4-00	1	gruppo tensione crochet inf.	tension assembly for lower looper	groupe tension crochet inférieur		
1	308556-0-00	1	astina	rod	tige		
2	705201-0-00	1	rondella	washer	rondelle		
3	740220-2-00	1	vite	screw	vis		
4	741413-2-00	2	vite	screw	vis		
5	302172-0-10	2	passafilo	thread guide	passe-fil		
6	741612-0-00	1	vite	screw	vis		
7	308558-0-00	1	traversino	tie-rod	traverse		
8	302204-0-10	1	pomolo	knob	pommeau		
9	300310-0-10	1	molla	spring	ressort		
10	704218-2-00	1	rondella	washer	rondelle		
11	200324-0-10	2	disco tensione	tension disc	disque tension		
12	300391-0-10	1	perno a vite	threaded pin	pivot à vis		
13	741642-2-00	1	vite	screw	vis		
14	302168-2-10	1	supporto	support	support		
15	308553-2-00	1	piastra	plate	plaque		
16	721444-2-00	2	vite	screw	vis		
17	308551-0-00	1	squadretta	bracket	équerre		
18	704104-2-00	2	vite	screw	vis		
19	740210-2-00	2	vite	screw	vis		
20	302136-0-12	1	passafilo	thread guide	passe-fil		
21	308137-0-00	1	cavallotto	coupling	cavalier		
22	308201-0-01	1	passafilo	thread guide	passe-fil		
23	724420-2-00	1	vite	screw	vis		
24	729012-2-00	1	vite	screw	vis		
25	741682-0-00	1	vite	screw	vis		
26	704302-4-00	1	rondella	washer	rondelle		
27	302149-0-11	1	passafilo	thread guide	passe-fil		
28	311098-0-00	2	passafilo	thread guide	passe-fil		
29	704210-4-00	2	rondella	washer	rondelle		
30	300483-0-10	2	vite	screw	vis		
31	303045-0-10	2	vite	screw	vis		
32	308217-0-01	2	guidafilo	thread guide	guide-fil		

Fig. N. Abb. N.	Part. N. Piece N. Bestell N. Pieza N.	Qt. Anzahl	DESCRIZIONE	DESCRIPTION	DESCRIPTION	BENENNUNG	DESCRIPCION
46	900716-0-10	1	albero	shaft	arbre		
47	729066-2-00	4	vite	screw	vis		
48	788720-0-00	1	targhetta	plate	plaque		
49	900691-0-10	1	basamento	base	base		
50	900201-0-10	7	chiodo	rivet	clou		
51	900317-0-10	1	protezione volantino	handwheel protection	protection volant		
52	724054-0-00	2	vite	screw	vis		
53	910355-0-00	1	piastra	plate	plaque		
54	900703-0-10	1	tappeto	carpet	tapis		
55	900704-2-10	1	cassetto	drawer	tiroir		
56	704409-2-00	1	rondella	washer	rondelle		
57	900708-0-10	1	molla	spring	ressort		
58	991191-0-00	1	carterino per canale scarica ritagli	cover for offlet	carter pour canal décharge-chutes		
11	306312-0-00	1	bloccetto (per passante 12 mm.)	block (for belt 12 mm.)	bloc (pour passant 12 mm.)		
	306320-0-00	1	bloccetto (per passante 15 mm.)	block (for belt 15 mm.)	bloc (pour passant 15 mm.)		
	306340-0-00	1	bloccetto (per passante 18 mm.)	block (for belt 18 mm.)	bloc (pour passant 18 mm.)		
	306360-0-00	1	bloccetto (per passante 20 mm.)	block (for belt 20 mm.)	bloc (pour passant 20 mm.)		
	Tav. 13						
6	927156-0-00	1	piadina supplementare (per passante 12 mm.)	supplementary pressfoot (for belt 12 mm.)	piéd presseur supplémentaire (pour passant 12 mm.)		
	A RICHIESTA						
6	927157-0-00	1	piadina supplementare (per passante 15 mm.)	supplementary pressfoot (for belt 15 mm.)	piéd presseur supplémentaire (pour passant 15 mm.)		
	927158-0-00	1	piadina supplementare (per passante 18 mm.)	supplementary pressfoot (for belt 18 mm.)	piéd presseur supplémentaire (pour passant 18 mm.)		
	927159-0-00	1	piadina supplementare (per passante 20 mm.)	supplementary pressfoot (for belt 20 mm.)	piéd presseur supplémentaire (pour passant 20 mm.)		

Fig. N. Abb. N.	Part. N. Bestell N. Piece N. Pieza N.	Qt. Anzahl	DESCRIZIONE	DESCRIPTION	DESCRIPTION	BENENNUNG	DESCRIPCION	Fig. N. Abb. N.
★	991120-5-01	1	porta bobine compl. (4-3 fili)	bobbin carrier ass. (4-3 threads)	porte bobine compl. (4-3 fils)			

Fig. N. Abb. N.	Part. N. Piecce N. Bestell N. Pieza N.	N. N. N. N.	Ct. Anzahl	DESCRIZIONE	DESCRIPTION	DESCRIPTION	BENENNUNG	DESCRIPCION
	309204-0-01			VARIANTE PER 261-40-2MN-12 (per passante 10 mm.)	VARIATION FOR 261-40-2MN-12 (for belt loop 10 mm.)	VARIANTE POUR 261-40-2MN-12 (pour passant 10 mm.)		
	Tav. 9							
▲ 26	309807-4-01		1	morsetto aghi completo	needle clamp assembly	porte-aiguille complet		
	309757-2-01		1	morsetto aghi	needle clamp	porte-aiguille		
	Tav. 11							
11	306241-0-00		1	blocchetto (per passante 10 mm.)	block (for belt 10 mm.)	bloc (pour passant 10 mm.)		
	A RICHIESTA							
11	306312-0-00		1	blocchetto (per passante 12 mm.)	block (for belt 12 mm.)	bloc (pour passant 12 mm.)		
	306320-0-00		1	blocchetto (per passante 15 mm.)	block (for belt 15 mm.)	bloc (pour passant 15 mm.)		
	306340-0-00		1	blocchetto (per passante 18 mm.)	block (for belt 18 mm.)	bloc (pour passant 18 mm.)		
	306350-0-00		1	blocchetto (per passante 20 mm.)	block (for belt 20 mm.)	bloc (pour passant 20 mm.)		
	Tav. 13							
6	927156-0-00		1	pedino supplementare (per passante 10 mm.)	supplementary presserfoot (for belt 10 mm.)	ped-presseur supplémentaire (pour passant 10 mm.)		
	A RICHIESTA							
6	927157-0-00		1	pedino supplementare (per passante 12 mm.)	supplementary presserfoot (for belt 12 mm.)	ped-presseur supplémentaire (pour passant 12 mm.)		
	927158-0-00		1	pedino supplementare (per passante 15 mm.)	supplementary presserfoot (for belt 15 mm.)	ped-presseur supplémentaire (pour passant 15 mm.)		
	927159-0-00		1	pedino supplementare (per passante 18 mm.)	supplementary presserfoot (for belt 18 mm.)	ped-presseur supplémentaire (pour passant 18 mm.)		
	927160-0-00		1	pedino supplementare (per passante 20 mm.)	supplementary presserfoot (for belt 20 mm.)	ped-presseur supplémentaire (pour passant 20 mm.)		

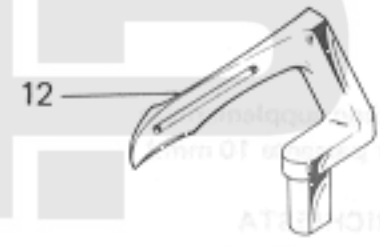
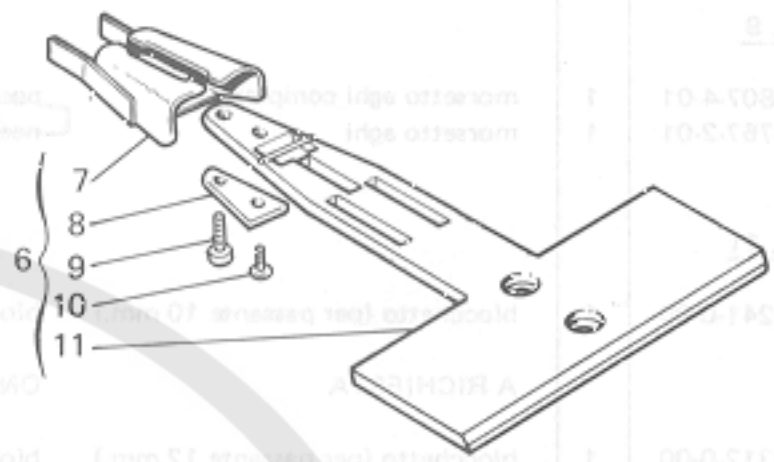
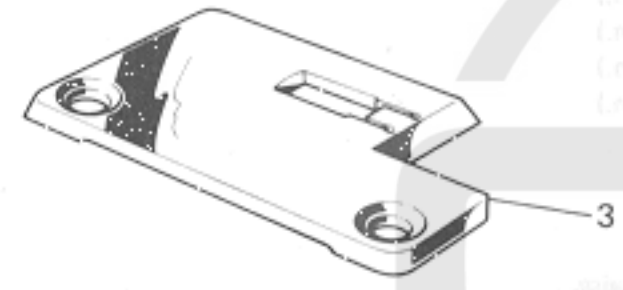
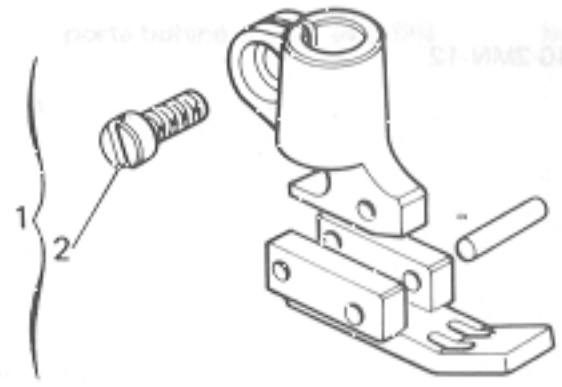
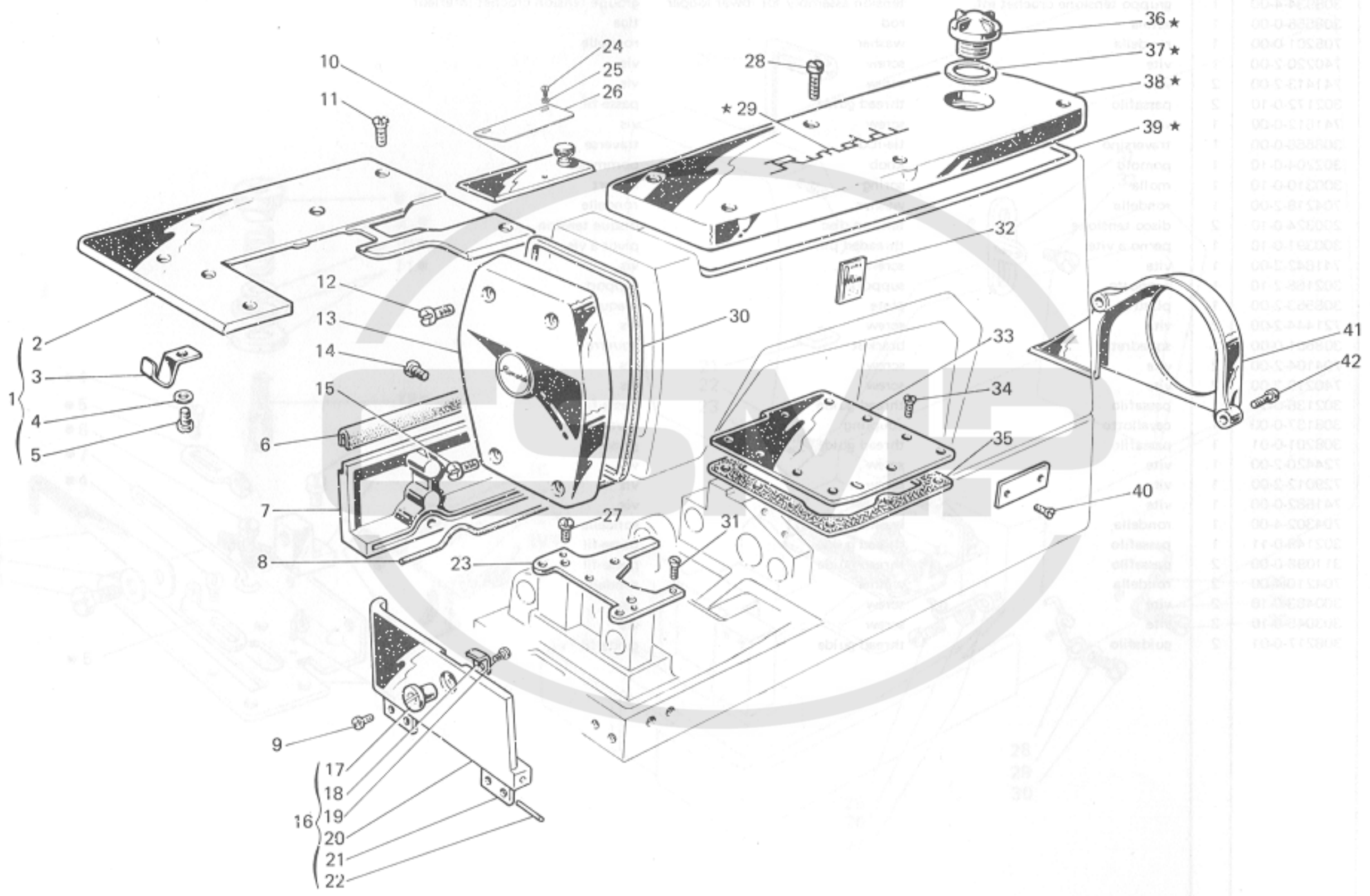

Fig. N°	Part N°	DESCRIPTION	Q.T.A.
4	308807-A-01	morsetto aghi conico	1
5	308787-3-01	morsetto aghi	1
6	308247-12-00	bloccetto (per passante 10 mm.)	1
7	308315-0-00	bloccetto (per passante 12 mm.)	1
8	308320-0-00	bloccetto (per passante 15 mm.)	1
9	308340-0-00	bloccetto (per passante 18 mm.)	1
10	308350-0-00	bloccetto (per passante 20 mm.)	1
11	927158-0-00	pedina supplementare (per passante 12 mm.)	1
12	927158-0-00	pedina supplementare (per passante 15 mm.)	1
13	927158-0-00	pedina supplementare (per passante 18 mm.)	1
	927158-0-00	pedina supplementare (per passante 20 mm.)	1

Fig. N. Abb. N.	Part. N. Piece N. Bestell N. Pieza N.	Qt. Anzahl	DESCRIZIONE	DESCRIPTION	DESCRIPTION	BENENNUNG	DESCRIPCION
1	306264-3-01	1	piedino completo (per passante 10 mm.)	presserfoot assembly (for belt loop 10 mm.)	pied-presseur complet (pour passant 10 mm.)		
2	741721-2-00	1	vite	screw	vis		
3	306207-0-10	1	placca ago	needle plate	plaque à aiguille		
4	306203-0-11	1	griffa principale	main feed-dog	griffe principale		
5	306218-0-00	1	griffa sussidiaria	subsidiary feed-dog	griffe subsidiaire		
6	927175-4-00	1	placca supplementare (per passante 10 mm.)	supplementary plate (for belt loop 10 mm.)	plaque supplémentaire (pour passant 10 mm.)		
7	306881-2-00	1	guida (per passante 10 mm.)	guide (for belt loop 10 mm.)	guide (pour passant 10 mm.)		
8	306274-0-00	1	blocchetto (per passante 10-12 mm.)	block (for belt loop 10-12 mm.)	bloc (pour passant 10-12 mm.)		
9	741453-0-00	1	vite	screw	vis		
10	744530-0-00	1	vite	screw	vis		
11	927169-4-00	1	placca supplementare (per passante 10 mm.)	supplementary needle plate (for belt loop 10 mm.)	plaque supplémentaire (pour passant 10 mm.)		
12	302057-0-13	1	crochet inferiore	lower looper	crochet inférieur		
13	780200-0-40	1	targhetta classe testa	head class plate	plaque-classe tête		
			SOLO A RICHIESTA	ONLY ON REQUEST	SEULEMENT SUR DEMANDE		
1	306317-3-01	1	piedino completo (per passante 12 mm.)	presserfoot assembly (for belt loop 12 mm.)	pied-presseur complet (pour passant 12 mm.)		
	306324-3-01	1	piedino completo (per passante 15 mm.)	presserfoot assembly (for belt loop 15 mm.)	pied-presseur complet (pour passant 15 mm.)		
	306365-3-01	1	piedino completo (per passante 18-20 mm.)	presserfoot assembly (for belt loop 18-20 mm.)	pied-presseur complet (pour passant 18-20 mm.)		
6	927176-4-00	1	placca supplementare (per passante 12 mm.)	supplementary plate (for belt loop 12 mm.)	plaque supplémentaire (pour passant 12 mm.)		
	927177-4-00	1	placca supplementare (per passante 15 mm.)	supplementary plate (for belt loop 15 mm.)	plaque supplémentaire (pour passant 15 mm.)		
	927178-4-00	1	placca supplementare (per passante 18 mm.)	supplementary plate (for belt loop 18 mm.)	plaque supplémentaire (pour passant 18 mm.)		
	927179-4-00	1	placca supplementare (per passante 20 mm.)	supplementary plate (for belt loop 20 mm.)	plaque supplémentaire (pour passant 20 mm.)		
7	306882-2-00	1	guida (per passante 12 mm.)	guide (for belt loop 12 mm.)	guide (pour passant 12 mm.)		
	306883-2-00	1	guida (per passante 15 mm.)	guide (for belt loop 15 mm.)	guide (pour passant 15 mm.)		
	306884-2-00	1	guida (per passante 18 mm.)	guide (for belt loop 18 mm.)	guide (pour passant 18 mm.)		
	306885-2-00	1	guida (per passante 20 mm.)	guide (for belt loop 20 mm.)	(pour passant 20 mm.)		
8	306275-0-00	1	blocchetto (per passante 15-18-20 mm.)	block (for belt loop 15-18-20 mm.)	bloc (pour passant 15-18-20 mm.)		
11	927170-4-00	1	placca supplementare (per passante 12 mm.)	supplementary plate (for belt loop 12 mm.)	plaque supplémentaire (pour passant 12 mm.)		
	927171-4-00	1	placca supplementare (per passante 15 mm.)	supplementary plate (for belt loop 15 mm.)	plaque supplémentaire (pour passant 15 mm.)		
	927172-4-00	1	placca supplementare (per passante 18 mm.)	supplementary plate (for belt loop 18 mm.)	plaque supplémentaire (pour passant 18 mm.)		
	927173-4-00	1	placca supplementare (per passante 20 mm.)	supplementary plate (for belt loop 20 mm.)	plaque supplémentaire (pour passant 20 mm.)		



Q.TA	Part. N°	Descrizione
1	30824-4-00	...
1	30825-0-00	...
2	30826-0-00	...
2	30827-0-00	...
2	30828-0-00	...
2	30829-0-00	...
2	30830-0-00	...
2	30831-0-00	...
2	30832-0-00	...
2	30833-0-00	...
2	30834-0-00	...
2	30835-0-00	...
2	30836-0-00	...
2	30837-0-00	...
2	30838-0-00	...
2	30839-0-00	...
2	30840-0-00	...
2	30841-0-00	...
2	30842-0-00	...
2	30843-0-00	...
2	30844-0-00	...
2	30845-0-00	...
2	30846-0-00	...
2	30847-0-00	...
2	30848-0-00	...
2	30849-0-00	...
2	30850-0-00	...
2	30851-0-00	...
2	30852-0-00	...
2	30853-0-00	...
2	30854-0-00	...
2	30855-0-00	...
2	30856-0-00	...
2	30857-0-00	...
2	30858-0-00	...
2	30859-0-00	...
2	30860-0-00	...
2	30861-0-00	...
2	30862-0-00	...
2	30863-0-00	...
2	30864-0-00	...
2	30865-0-00	...
2	30866-0-00	...
2	30867-0-00	...
2	30868-0-00	...
2	30869-0-00	...
2	30870-0-00	...
2	30871-0-00	...
2	30872-0-00	...
2	30873-0-00	...
2	30874-0-00	...
2	30875-0-00	...
2	30876-0-00	...
2	30877-0-00	...
2	30878-0-00	...
2	30879-0-00	...
2	30880-0-00	...
2	30881-0-00	...
2	30882-0-00	...
2	30883-0-00	...
2	30884-0-00	...
2	30885-0-00	...
2	30886-0-00	...
2	30887-0-00	...
2	30888-0-00	...
2	30889-0-00	...
2	30890-0-00	...
2	30891-0-00	...
2	30892-0-00	...
2	30893-0-00	...
2	30894-0-00	...
2	30895-0-00	...
2	30896-0-00	...
2	30897-0-00	...
2	30898-0-00	...
2	30899-0-00	...
2	30900-0-00	...



Fig. N. Abb. N.	Part. N. Piece N. Bestell N. Pieza N.	Qt. Anzahl	DESCRIZIONE	DESCRIPTION	DESCRIPTION	BENENNUNG	DESCRIPCION
★	308103-4-10	1	coperchio superiore compl.	upper cover assembly	grouppe porte griffe completa	couvercle supérieur compl.	
1	309072-4-00	1	piano di lavoro compl.	working plate assembly	grouppe piano di lavoro completo	plan de travail complet	
2	309053-2-00	1	piano di lavoro	working plate	grouppe piano di lavoro	plan de travail	
3	309351-0-00	1	molla	spring	spring	ressort	
4	704306-0-00	1	rondella	washer	washer	rondelle	
5	720411-2-00	1	vite	screw	screw	vis	
6	309088-0-00	1	guarnizione	gasket	gasket	garniture	
7	309086-0-01	1	carter posteriore	rear cover	rear cover	carter supérieur	
8	309084-0-00	1	guarnizione	gasket	gasket	garniture	
9	300483-0-10	4	vite per cerniera	screw for hinge	screw for hinge	vis pour charnière	
10	306344-2-00	1	coperchio scorrevole	sliding cover	sliding cover	couvercle coulissant	
11	744636-2-00	5	vite	screw	screw	vis	
12	302354-0-10	2	vite superiore	upper screw	upper screw	vis supérieure	
13	308101-2-00	1	coperchio laterale	side cover	side cover	couvercle latéral	
14	741088-2-00	3	vite per carter posteriore	screw for rear cover	screw for rear cover	vis pour carter arrière	
15	302353-0-10	2	vite inferiore	lower screw	lower screw	vis inférieure	
16	927247-4-00	1	carter laterale completo	side cover assembly	side cover assembly	carter latéral complet	
17	309372-0-00	1	perno	pin	pin	pivot	
18	309371-0-00	1	chiavistello	key	key	clé	
19	741658-2-00	1	vite	screw	screw	vis	
20	927248-3-00	1	carter laterale	side cover	side cover	carter latéral	
21	309332-0-00	2	cerniera	hinge	hinge	charnière	
22	707556-0-00	2	spina	pin	pin	goupille	
23	308783-2-00	1	piastra porta piacca	plate	plate	plaque	
24	741510-0-00	2	vite	screw	screw	vis	
25	704104-2-00	2	rondella	washer	washer	rondelle	
26	927232-0-00	1	piastrina	plate	plate	plaque	
27	302355-0-10	2	vite per piastra	screw for plate	screw for plate	vis pour plaque	
28	742282-2-00	6	vite per coperchio	screw for cover	screw for cover	vis pour couvercle	
29	300006-0-12	2	decalcomania	decalcomania	decalcomania	décalcomanie	
30	308128-0-00	1	guarnizione coperchio	cover gasket	cover gasket	garniture couvercle	
31	744730-0-00	2	vite per piastra ago	screw for needle plate	screw for needle plate	vis pour plaque aiguille	
32	788020-0-01	1	decalcomania sistema aghi	needles decalcomania	needles decalcomania	décalcomanie système aiguilles	
33	309324-2-10	1	piastra superiore	upper plate	upper plate	plaque supérieure	
34	741936-2-00	10	vite per piastra	screw for plate	screw for plate	vis pour plaque	
35	309323-0-00	1	guarnizione	gasket	gasket	garniture	
36	202239-0-10	1	cupolina	cup	cup	cupole	
37	705970-0-00	1	guarnizione per cupolina	gasket	gasket	garniture	
38	308102-0-00	1	coperchio superiore	upper cover	upper cover	couvercle supérieur	
39	308129-0-00	1	guarnizione per coperchio	gasket for cover	gasket for cover	garniture pour couvercle	
40	202165-0-10	2	vite per targhetta	screw for plate	screw for plate	vis pour plaquette	
41	308462-0-00	1	carter copricinghia	cover	cover	carter	
42	721475-2-00	2	vite	screw	screw	vis	

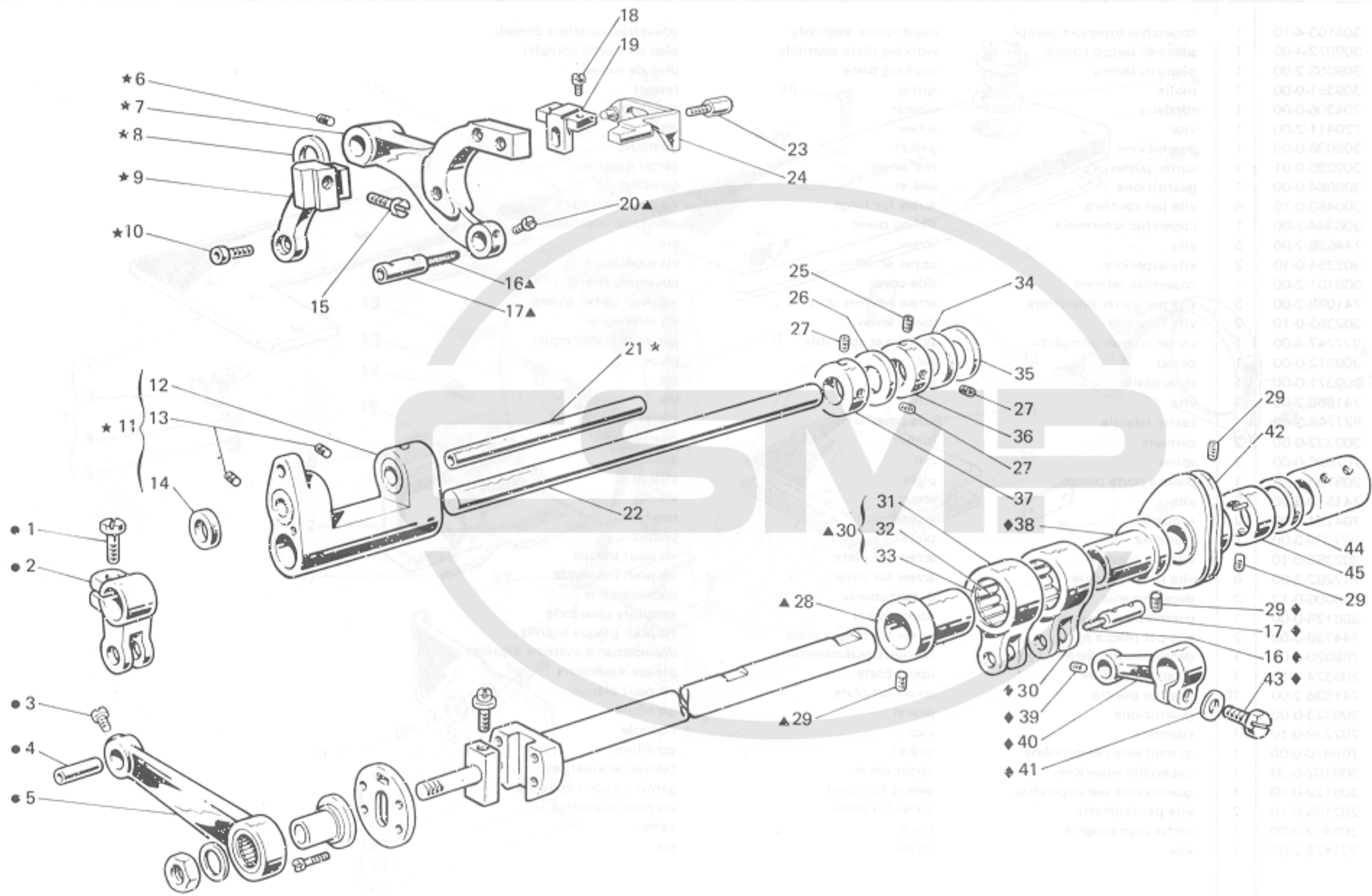
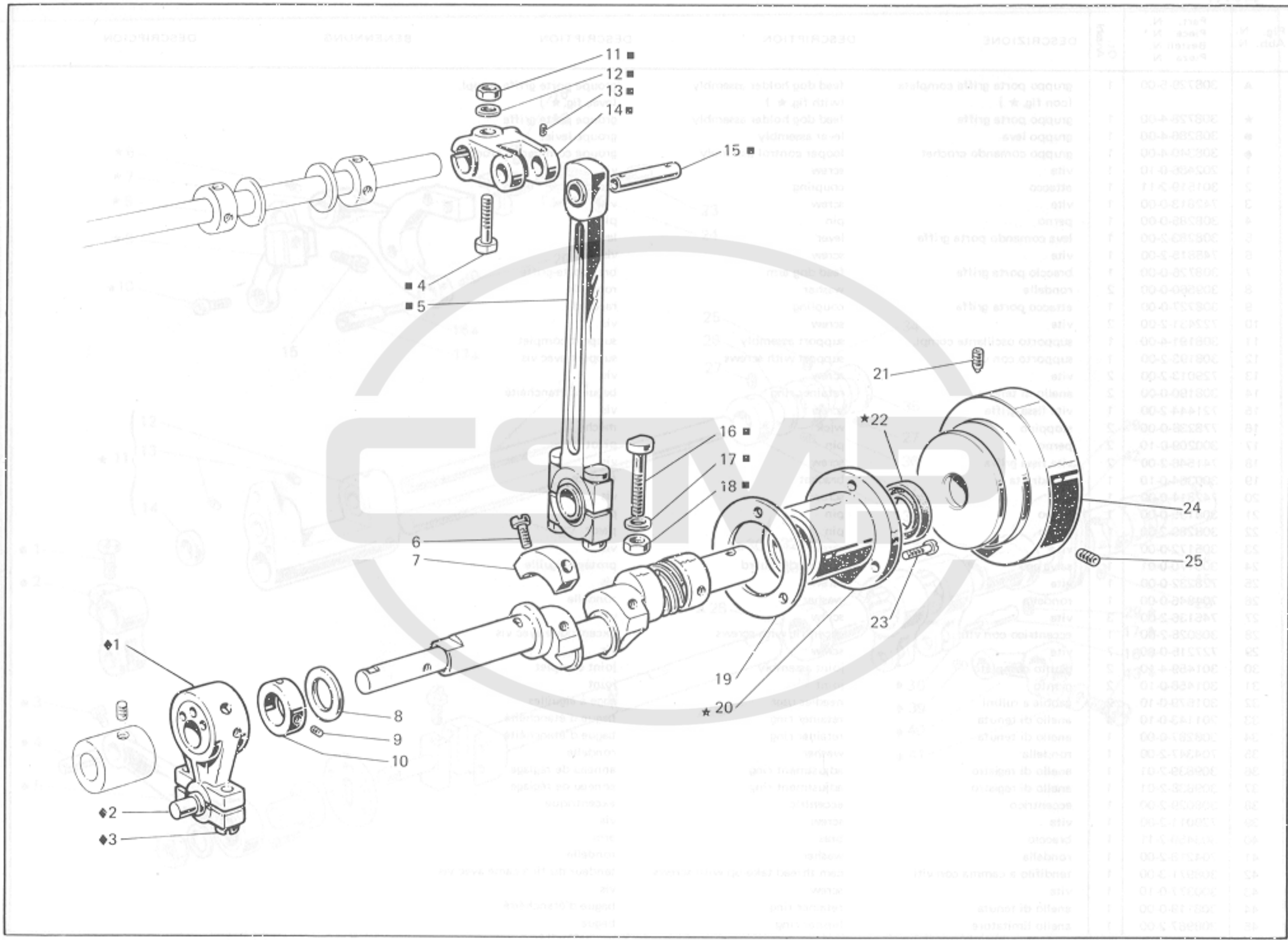

Fig. N°	Descrizione	Q.tà
1	308103-4-10	4
2	308073-4-00	1
3	308023-3-00	2
4	308021-0-00	1
5	308008-0-00	1
6	308011-3-00	1
7	308028-0-00	1
8	308085-0-01	1
9	308084-0-00	1
10	308083-0-10	4
11	308044-3-00	1
12	308034-0-10	2
13	308101-3-00	1
14	308102-3-00	2
15	308025-0-10	4
16	308043-4-00	1
17	308013-0-00	1
18	308031-0-00	1
19	308022-3-00	1
20	308032-0-00	1
21	308033-0-00	1
22	308034-0-00	1
23	308035-0-00	1
24	308036-0-00	1
25	308037-0-00	1
26	308038-0-00	1
27	308039-0-00	1
28	308040-0-00	1
29	308041-0-00	1
30	308042-0-00	1
31	308043-0-00	1
32	308044-0-00	1
33	308045-0-00	1
34	308046-0-00	1
35	308047-0-00	1
36	308048-0-00	1
37	308049-0-00	1
38	308050-0-00	1
39	308051-0-00	1
40	308052-0-00	1
41	308053-0-00	1
42	308054-0-00	1
43	308055-0-00	1
44	308056-0-00	1
45	308057-0-00	1

Fig. N. Abb. N.	Part. N. Piece N. Bestell N. Pieza N.	Qt. Anzahl	DESCRIZIONE	DESCRIPTION	DESCRIPTION	BENENNUNG	DESCRIPCION
▲	308729-5-00	1	gruppo porta griffa completa (con fig. ★)	feed dog holder assembly (with fig. ★)	groupe porte griffe compl. (avec fig. ★)		
★	308728-4-00	1	gruppo porta griffa	feed dog holder assembly	groupe porte griffe		
●	308286-4-00	1	gruppo leva	lever assembly	groupe levier		
◆	308340-4-00	1	gruppo comando crochet	looper control assembly	groupe commande crochet		
1	202486-0-10	1	vite	screw	vis		
2	301519-2-11	1	attacco	coupling	raccord		
3	742813-0-00	1	vite	screw	vis		
4	308285-0-00	1	perno	pin	pivot		
5	308283-2-00	1	leva comando porta griffa	lever	levier		
6	745815-2-00	1	vite	screw	vis		
7	308726-0-00	1	braccio porta griffa	feed dog arm	bras porte-griffe		
8	309560-0-00	2	rondella	washer	rondelle		
9	308727-0-00	1	attacco porta griffa	coupling	raccord		
10	722431-2-00	2	vite	screw	vis		
11	308191-4-00	1	supporto oscillante compl.	support assembly	support complet		
12	308193-2-00	1	supporto con viti	support with screws	support avec vis		
13	729013-2-00	2	vite	screw	vis		
14	308190-0-00	2	anello di tenuta	retainer ring	bague d'étanchéité		
15	721444-2-00	1	vite fissa griffa	screw	vis		
16	778238-0-00	2	stoppino	wick	mèche		
17	300209-0-10	2	perno	pin	pivot		
18	741546-2-00	2	vite fissa griffa	screw	vis		
19	300364-0-10	1	squadretta	bracket	équerre		
20	742811-0-00	1	vite	screw	vis		
21	308195-0-00	1	perno	pin	pivot		
22	308289-2-00	1	perno	pin	pivot		
23	305172-0-00	1	vite	screw	vis		
24	305170-0-01	1	salva ago	rear needle guard	protège-aiguille		
25	728232-0-00	1	vite	screw	vis		
26	704846-0-00	1	rondella	washer	rondelle		
27	745136-2-00	3	vite	screw	vis		
28	308028-2-00	1	eccentrico con viti	eccentric with screws	excentrique avec vis		
29	727215-0-00	7	vite	screw	vis		
30	301459-4-10	2	giunto completo	joint assembly	joint complet		
31	301458-0-10	2	giunto	joint	joint		
32	301579-0-10	2	gabbia a rullini	needles cage	cage à aiguilles		
33	201143-0-10	4	anello di tenuta	retainer ring	bague d'étanchéité		
34	308287-0-00	1	anello di tenuta	retainer ring	bague d'étanchéité		
35	704347-2-00	1	rondella	washer	rondelle		
36	309839-2-01	1	anello di registro	adjustment ring	anneau de réglage		
37	309838-2-01	1	anello di registro	adjustment ring	anneau de réglage		
38	308029-2-00	1	eccentrico	eccentric	excentrique		
39	729011-2-00	1	vite	screw	vis		
40	303459-2-11	1	braccio	bras	arm		
41	704218-2-00	1	rondella	washer	rondelle		
42	308971-3-00	1	tendifilo a camma con viti	cam thread take-up with screws	tendeur du fil à came avec vis		
43	300377-0-10	1	vite	screw	vis		
44	308119-0-00	1	anello di tenuta	retainer ring	bague d'étanchéité		
45	308967-2-00	1	anello limitatore	limiter ring	bsgue		



Q. T.	Part. N. Descr. N. Part. N.	Q. T.	Part. N. Descr. N. Part. N.
1	308750-2-00	1	gruppo porta griffe completo
1	308750-4-00	1	gruppo porta griffe completo
1	308280-4-00	1	gruppo leva
1	308740-4-00	1	gruppo comando encoder
1	302480-0-10	1	vitte
2	301510-2-11	1	albero
3	742913-0-00	1	vitte
4	308280-0-00	1	perno
5	308280-2-00	1	leva comando porta griffe
6	748810-2-00	1	vitte
7	308750-0-00	1	braccio porta griffe
8	302960-0-00	2	fondello
9	308237-0-00	1	albero porta griffe
10	732427-2-00	2	vitte
11	308191-4-00	1	apposito oscillante completo
12	308192-2-00	1	apposito con vite
13	729073-2-00	2	vitte
14	308180-0-00	2	anello
15	731444-2-00	1	vitte
16	738230-0-00	2	braccio
17	302200-0-10	2	perno
18	741540-2-00	2	vitte
19	302940-0-10	1	braccio
20	742913-0-00	1	vitte
21	308280-2-00	1	albero con vite
22	732110-0-00	2	vitte
23	301480-4-10	2	gruppo oscillante
24	301480-0-10	2	gruppo oscillante
25	308280-2-00	1	albero con vite
26	738230-0-00	1	braccio
27	302200-0-10	2	perno
28	741540-2-00	2	vitte
29	302940-0-10	1	braccio
30	742913-0-00	1	vitte
31	301480-4-10	2	gruppo oscillante
32	301480-0-10	2	gruppo oscillante
33	301480-0-10	2	gruppo oscillante
34	308280-2-00	1	albero con vite
35	704247-2-00	1	braccio
36	308280-2-01	1	albero di ingranaggio
37	308280-2-01	1	albero di ingranaggio
38	308020-2-00	1	eccentrico
39	720071-2-00	1	vitte
40	704247-2-11	1	braccio
41	704247-2-00	1	braccio
42	308237-2-00	1	braccio con vite
43	302371-0-10	1	vitte
44	302110-0-00	1	anello di tenuta
45	708827-2-00	1	anello limitatore