

TABLE OF CONTENTS

S-311

Main Stitch Shaft	3-2
Needle Bar Drive	3-4
Bite Adjustments and Barrell	3-6
Take-Up Lever	3-8
Needle Bar and Gear	3-10
Thread Release	3-12
Head and Lubrication	3-14
Race	3-16
Stitch Shaft and Drive	3-18
Turning Mechanism	3-20
Cutting Lever Assembly	3-22
Knife Drive	3-24
Lubrication Mechanism	3-26
Case	3-28
X-Y Table Movement	3-30
Bed Plate Assembly	3-32
Clamping — AF	3-34
Clamping — AF/ACL	3-36
Covers	3-38
Head Pneumatic Parts Standard	3-40
Control Box — Pneumatic Parts	3-42
Exhaust -Pneumatic Parts	3-44
Head Electronic Parts	3-46
Table	3-48
Electronic Box -Electronic Parts — I	3-50
Electronic Box -Electronic Parts — II	3-52
Electronic Box -Electronic Parts — III	3-54
Version AF	3-56
Version CT	3-58
Version CT Clamping	3-62
Version CT/LTT — Thread Clamp	3-66
Version LTT	3-68
Version LTT — Clamping	3-70
Version ACL	3-74
Version RDE	3-76
Clamping RDE	3-78
LED Light	3-80
Tools/Accessories	3-82

S-311 Indexer

Base and Clamp	3-2 I
Power	3-4 I
Covers	3-6 I
Clamping - AF+I	3-8 I
Clamping - CT+I	3-10 I
Table	3-14 I
Electronic box - Electronic parts I	3-14 I
Electronic box - Electronic parts II	3-18 I
Electronic box - Electronic parts III	3-20 I

Revised 01/2007

E-mail: service@amfreece.cz; parts@amfreece.cz; website: www.amfreece.com

Phones: +420 582 309 146 (Service), +420 582 309 286 (Spare Parts); Fax: +420 582 360 606

MAIN STITCH SHAFT

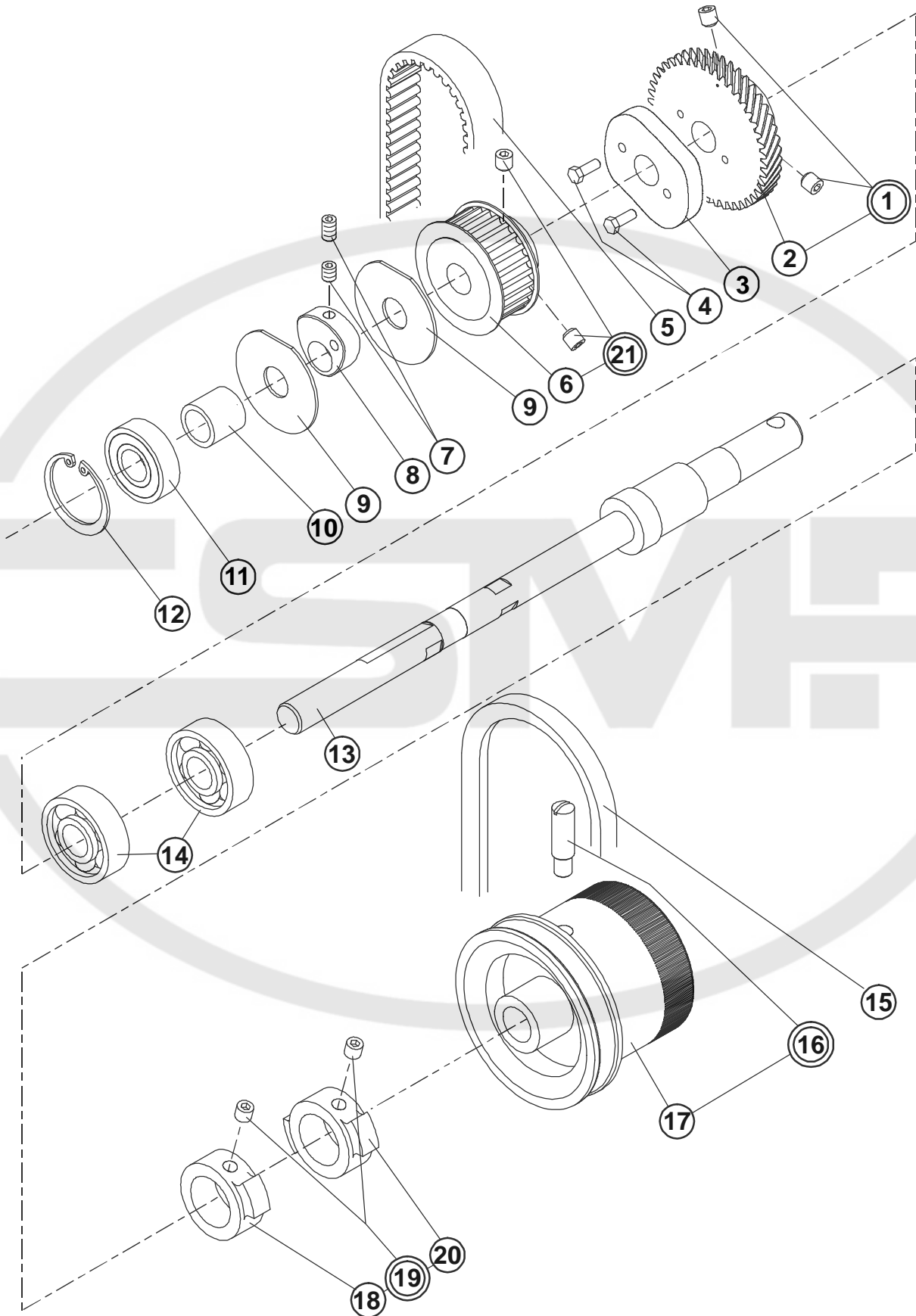

Revised 01/2007

E-mail: service@amfreece.cz; parts@amfreece.cz; website: www.amfreece.com

Phones: +420 582 309 146 (Service), +420 582 309 286 (Spare Parts); Fax: +420 582 360 606

MAIN STITCH SHAFT

DET	PART NUMBER	DESCRIPTION	QTY.
01	08.6400.6.008	Screw M6x8	(2)
02	19.0055.2.402	Gear	1
03	19.0067.2.416	Cam	1
04	17.0014.1.071	Screw M4x14	2
05	12.5050.2.008	Timing Belt	1
06	19.0055.4.421	Pulley	1
07	08.6400.5.005	Screw M5x5	2
08	19.0067.2.415	Counterweight	1
09	17.0081.4.376	Washer	2
10	19.0041.0.689	Shaft Bushing	1
11	12.2010.0.011	Bearing	1
12	12.1040.1.002	U-Clip	1
13	19.0034.9.403	Shaft	1
14	12.2010.0.023	Bearing	2
15	12.5050.1.008	V-Belt	1
16	18.0011.3.400	Screw	(1)
17	19.0051.0.409	Pulley	1
18	19.0044.1.624	Ring Sensor	1
19	17.0011.2.013	Screw	(2)
20	19.0044.1.625	Sensor Ring	1
21	08.6400.6.006	Screw M6x6	(2)

Revised 01/2007

E-mail: service@amfreece.cz; parts@amfreece.cz; website: www.amfreece.com

Phones: +420 582 309 146 (Service), +420 582 309 286 (Spare Parts); Fax: +420 582 360 606

NEEDLE BAR DRIVE

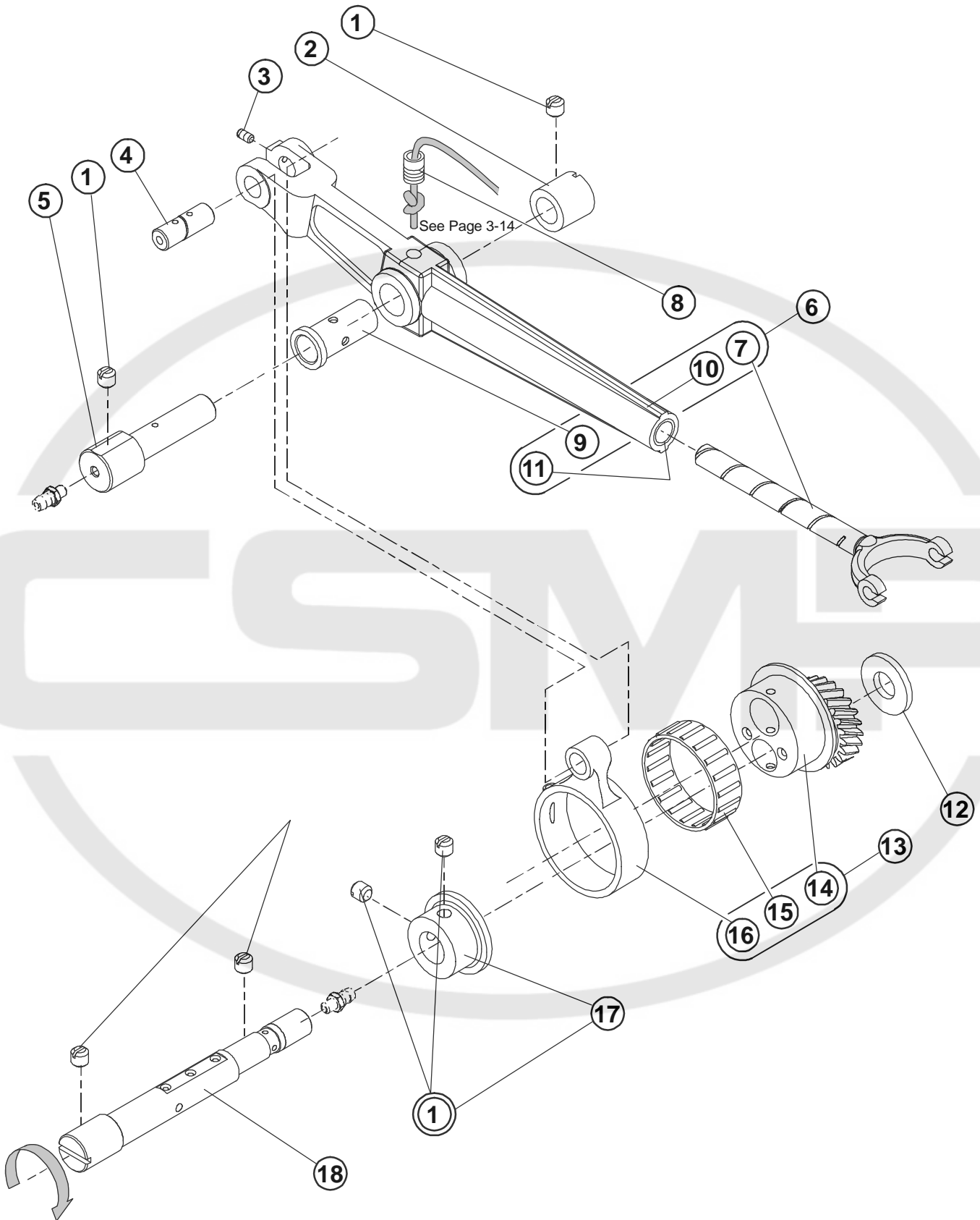

Revised 01/2007

E-mail: service@amfreece.cz; parts@amfreece.cz; website: www.amfreece.com
Phones: +420 582 309 146 (Service), +420 582 309 286 (Spare Parts); Fax: +420 582 360 606

BITE ADJUSTMENTS AND BARRELL

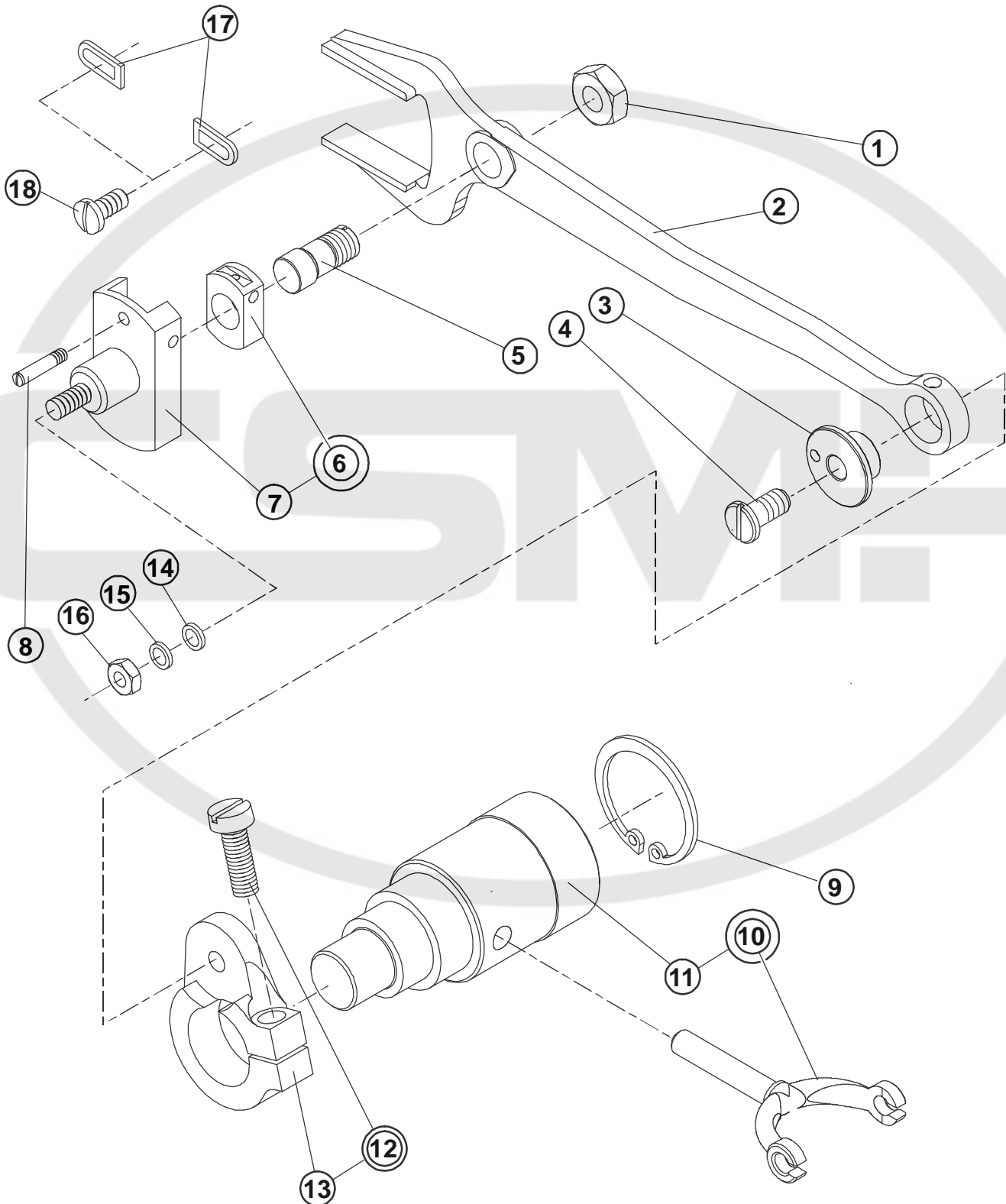

Revised 01/2007

E-mail: service@amfreece.cz; parts@amfreece.cz; website: www.amfreece.com
Phones: +420 582 309 146 (Service), +420 582 309 286 (Spare Parts); Fax: +420 582 360 606

TAKE-UP LEVER

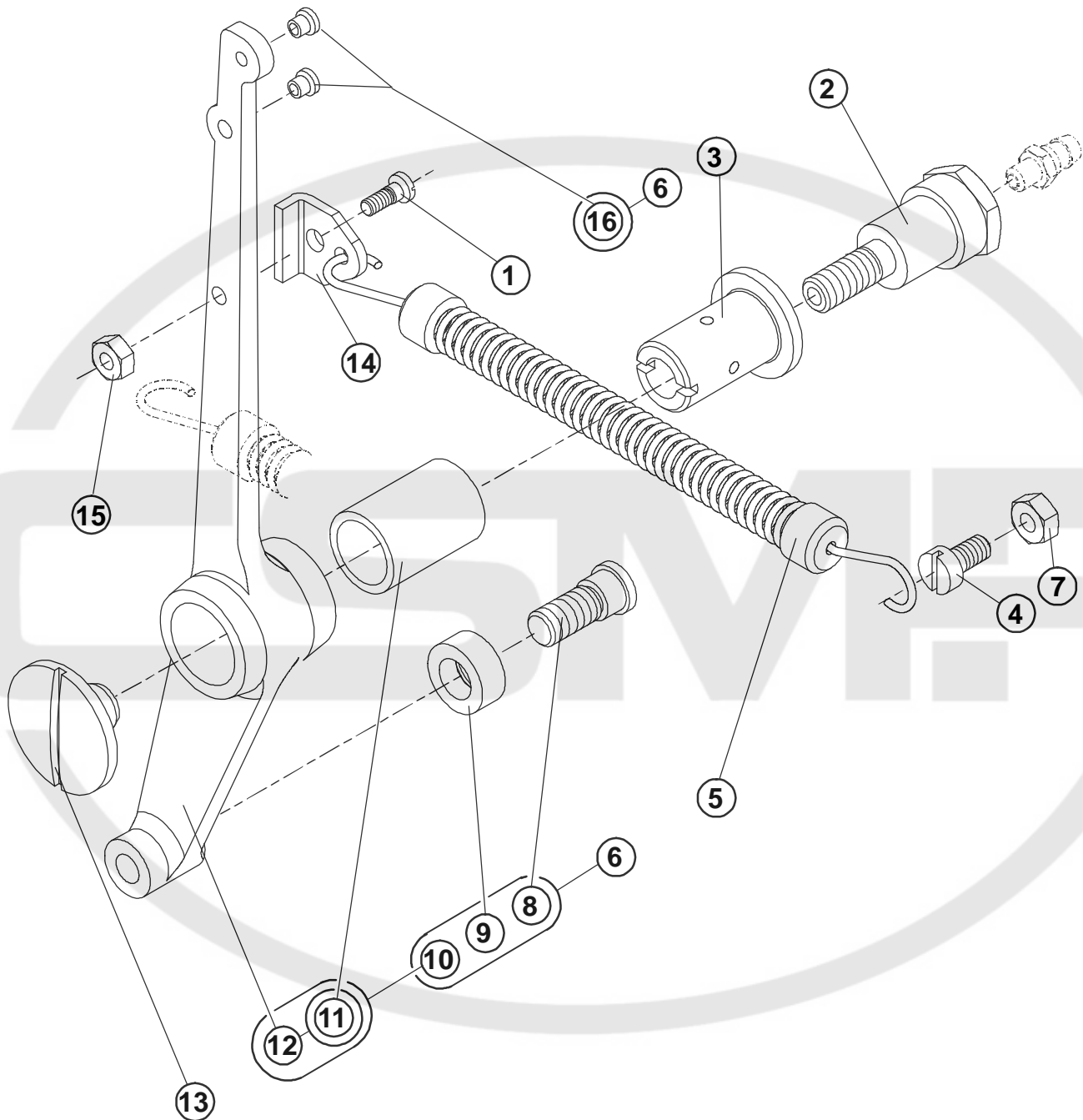

Revised 01/2007

E-mail: service@amfreece.cz; parts@amfreece.cz; website: www.amfreece.com

Phones: +420 582 309 146 (Service), +420 582 309 286 (Spare Parts); Fax: +420 582 360 606

TAKE-UP LEVER

DET	PART NUMBER	DESCRIPTION	QTY.
01	08.6032.3.008	Screw	1
02	19.0014.3.404	Screw	1
03	19.0033.8.403	Stud	1
04	08.6000.4.020	Screw	1
05	19.0026.3.400	Spring	1
06	19.0002.8.104	Take-Up Lever Assembly	1
07	08.6700.4.000	Nut	1
08	19.0033.2.401	Screw	(2)
09	17.0041.8.152	Roll	(1)
10	19.0063.3.400	Take-Up Lever	(1)
11	12.2080.0.002	Bushing	((1))
12	—————	Part Of Assembly Only 19.0063.3.400	● (1)
13	17.0015.3.022	Screw	1
14	19.0082.3.461	Spring Holder	1
15	08.6700.3.000	Nut	1
16	—————	Bushing, Thread Lever	(2)

Revised 01/2007

E-mail: service@amfreece.cz; parts@amfreece.cz; website: www.amfreece.com

Phones: +420 582 309 146 (Service), +420 582 309 286 (Spare Parts); Fax: +420 582 360 606

NEEDLE BAR AND GEAR

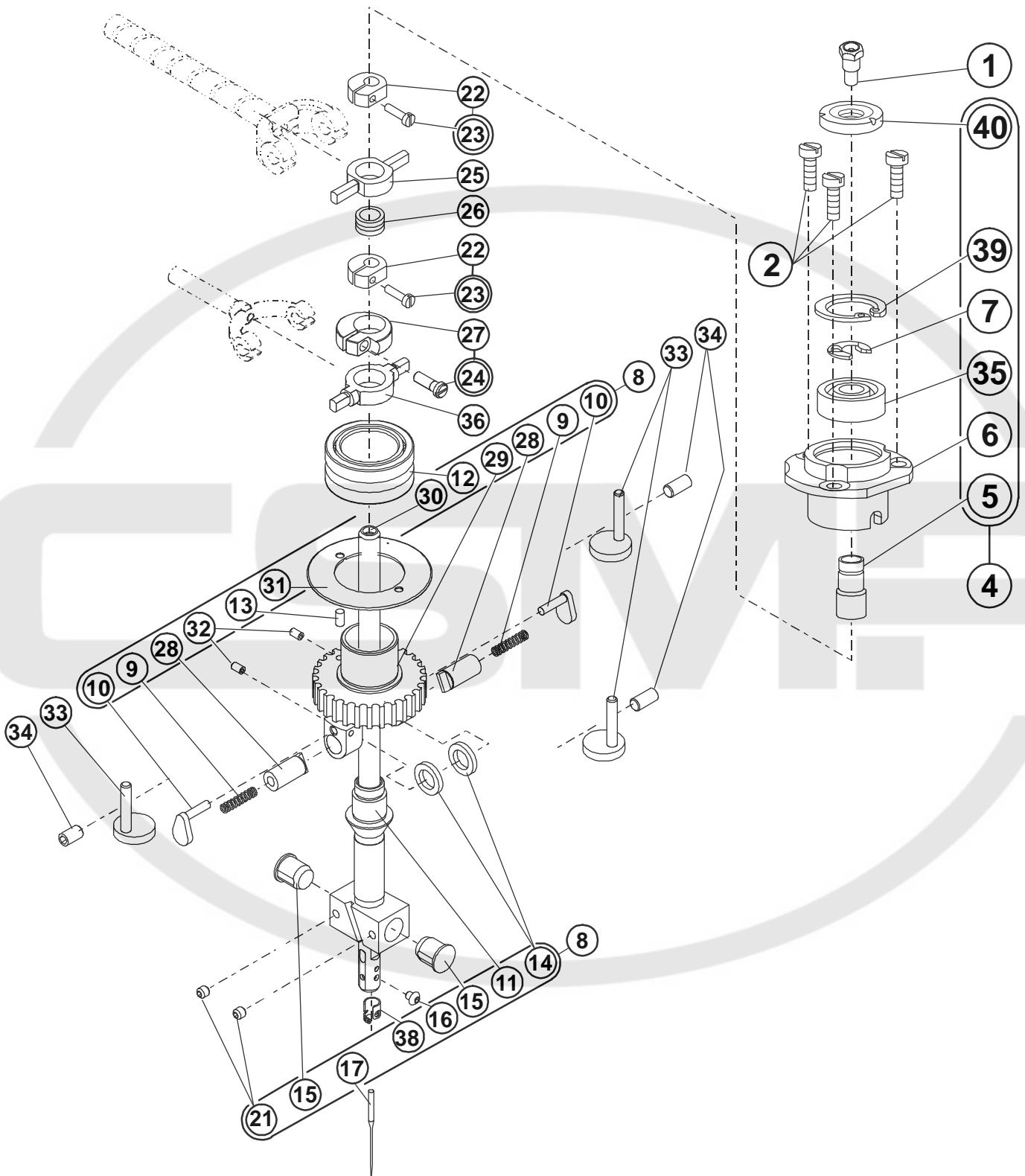

Revised 01/2007

E-mail: service@amfreece.cz; parts@amfreece.cz; website: www.amfreece.com
 Phones: +420 582 309 146 (Service), +420 582 309 286 (Spare Parts); Fax: +420 582 360 606

NEEDLE BAR AND GEAR

DET	PART NUMBER	DESCRIPTION	QTY.
01	14.1032.3.000	Bushing	1
02	08.6012.4.010	Screw	3
03			
04	19.0002.4.402	Needle Bar Guide Assembly	1
05	17.0042.1.283	Bushing	(1)
06	19.0044.5.403	Bushing	(1)
07	17.0027.4.035	Retaining Ring	(1)
08	19.0002.1.403	Needle Bushing Assembly	1
09	01.5003.0.000	Spring	(2)
10	10.1021.2.000	Retainer Spring	(2)
11	19.0041.6.401	Block	(1)
12	12.2050.1.010	Bushing	1
13	17.0031.0.359	Pin 3x6	(1)
14	17.0019.1.062	Retainer Washer	(2)
15	14.1025.3.000	Needle Bar Button	(2)
16	19.0011.1.401	Screw	(1)
17	02.0558.0.111	Needle	1
18			
19			
20			
21	18.0011.2.400	Screw	(2)
22	17.0043.6.277	Clamp Nut Kit	● 2
23	17.0012.0.120	Screw	(2)
24	17.0012.0.543	Screw	(1)
25	19.0045.3.402	Gimbal	1
26	19.0041.0.692	Bushing	1
27	17.0043.6.351	Adjustable Collar	● 1
28	17.0031.3.027	Guide	(1)
29	19.0055.4.403	Needle Bar Gear	● (1)
30	14.1028.4.000	Needle Bar	(1)
31	19.0019.0.687	Washer	(1)
32	08.6400.3.005	Screw M3x5	(2)
33	19.0033.8.406	Retainer	3
34	08.6400.4.010	Screw	3
35	12.2010.1.001	Bushing 108	(1)
36	19.0045.3.400	Gimbal Head	1
37			
38	19.0082.1.406	Thread Guide	(1)
39	12.1040.1.001	Ring	(1)
40	17.0044.2.229	Washer	(1)

Revised 01/2007

E-mail: service@amfreece.cz; parts@amfreece.cz; website: www.amfreece.com

Phones: +420 582 309 146 (Service), +420 582 309 286 (Spare Parts); Fax: +420 582 360 606

THREAD RELEASE

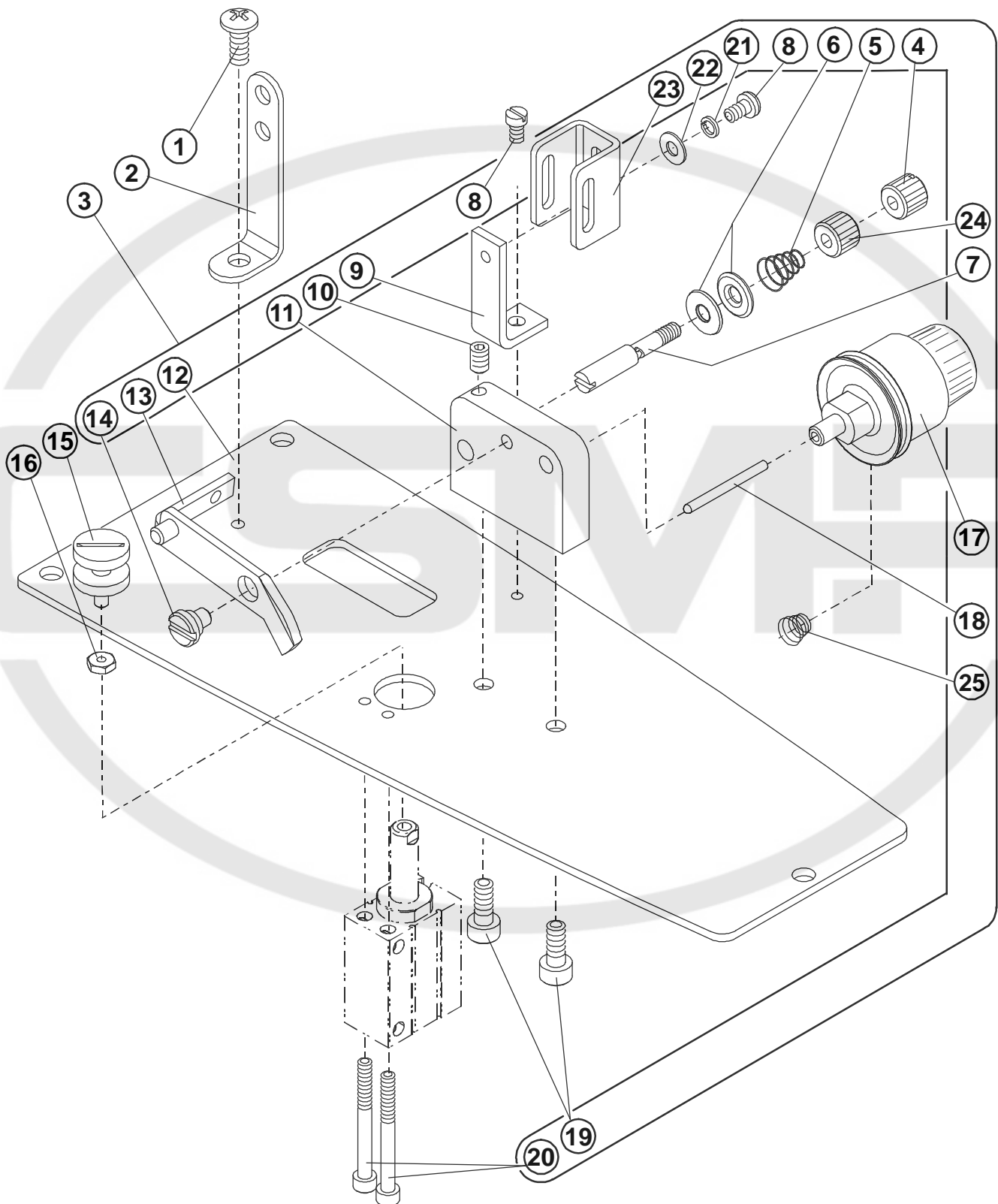

Revised 01/2007

E-mail: service@amfreece.cz; parts@amfreece.cz; website: www.amfreece.com

Phones: +420 582 309 146 (Service), +420 582 309 286 (Spare Parts); Fax: +420 582 360 606

HEAD AND LUBRICATION

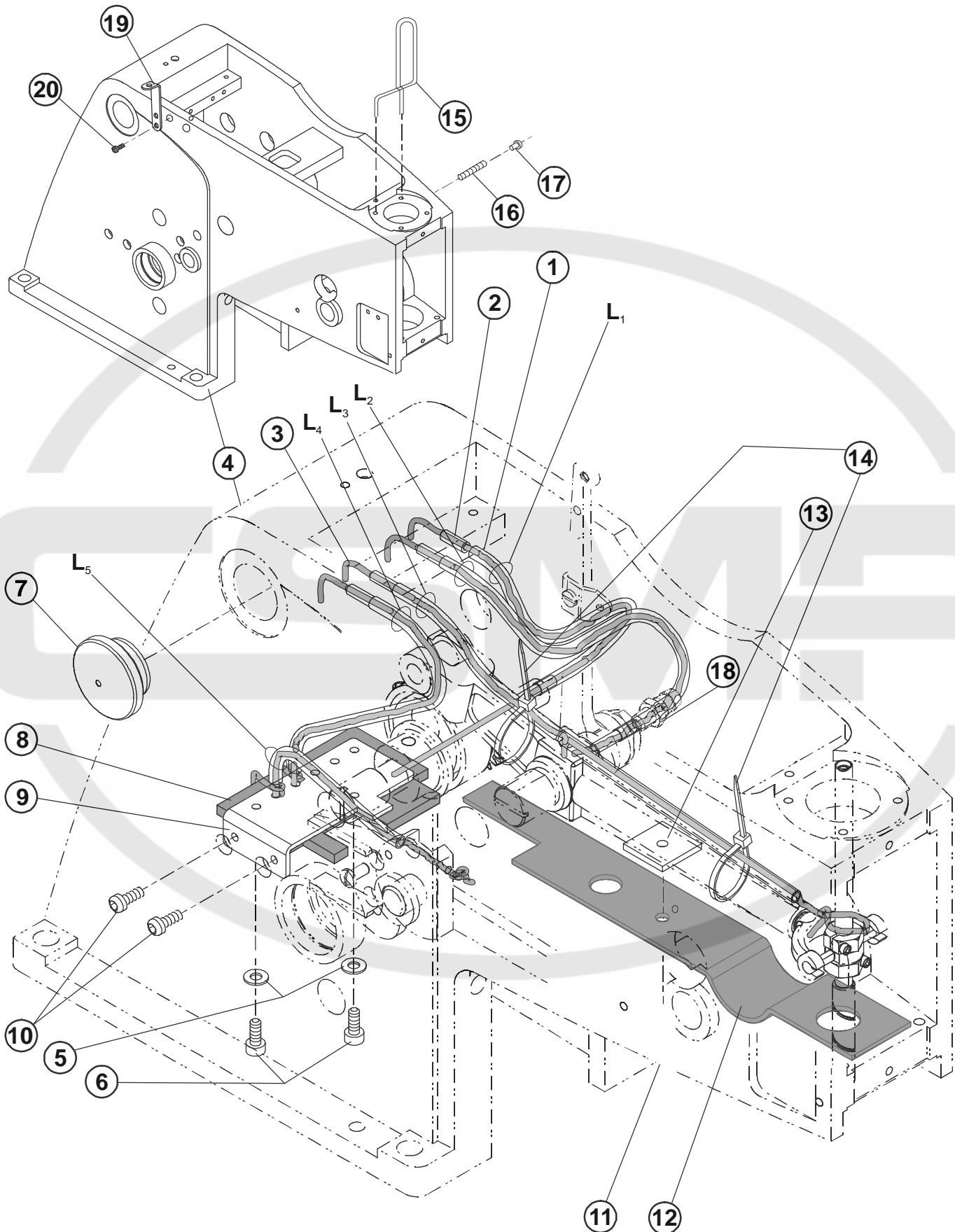

Revised 01/2007

E-mail: service@amfreece.cz; parts@amfreece.cz; website: www.amfreece.com

Phones: +420 582 309 146 (Service), +420 582 309 286 (Spare Parts); Fax: +420 582 360 606

HEAD AND LUBRICATION

DET	PART NUMBER	DESCRIPTION	QTY.
01	19.0094.2.412	Oil Tube L ₁ = 150 mm L ₂ = 150 mm L ₃ = 225 mm L ₄ = 180 mm L ₅ = 120 mm	1
02	19.0094.2.409	Joint PM	7
03	19.0094.5.412	Wick L ₁ = 400 mm L ₂ = 400 mm L ₃ = 550 mm L ₄ = 450 mm L ₅ = 200 mm	1
04	19.0071.3.403	Head	1
05	08.6000.4.010	Screw	2
06	08.6850.4.000	Washer	2
07	17.0095.1.329	Oil Indicator	1
08	19.0094.5.402	Felt	1
09	19.0082.3.407	Plate	1
10	08.6200.4.008	Screw	2
11	08.6000.4.020	Screw	1
12	19.0094.5.401	Felt	1
13	19.0081.5.415	Plate	1
14	12.0008.3.023	Ty-wrap	2
15	17.0027.1.419	Guard	1
16	08.6400.4.010	M4x10 Screw	1
17	12.0008.4.570	Plug	1
18	19.0044.1.623	Nipple	1
19	05.0043.1.000	Thread Smoother	1
20	08.6032.4.008	Screw	1

Revised 01/2007

E-mail: service@amfreece.cz; parts@amfreece.cz; website: www.amfreece.com

Phones: +420 582 309 146 (Service), +420 582 309 286 (Spare Parts); Fax: +420 582 360 606

RACE

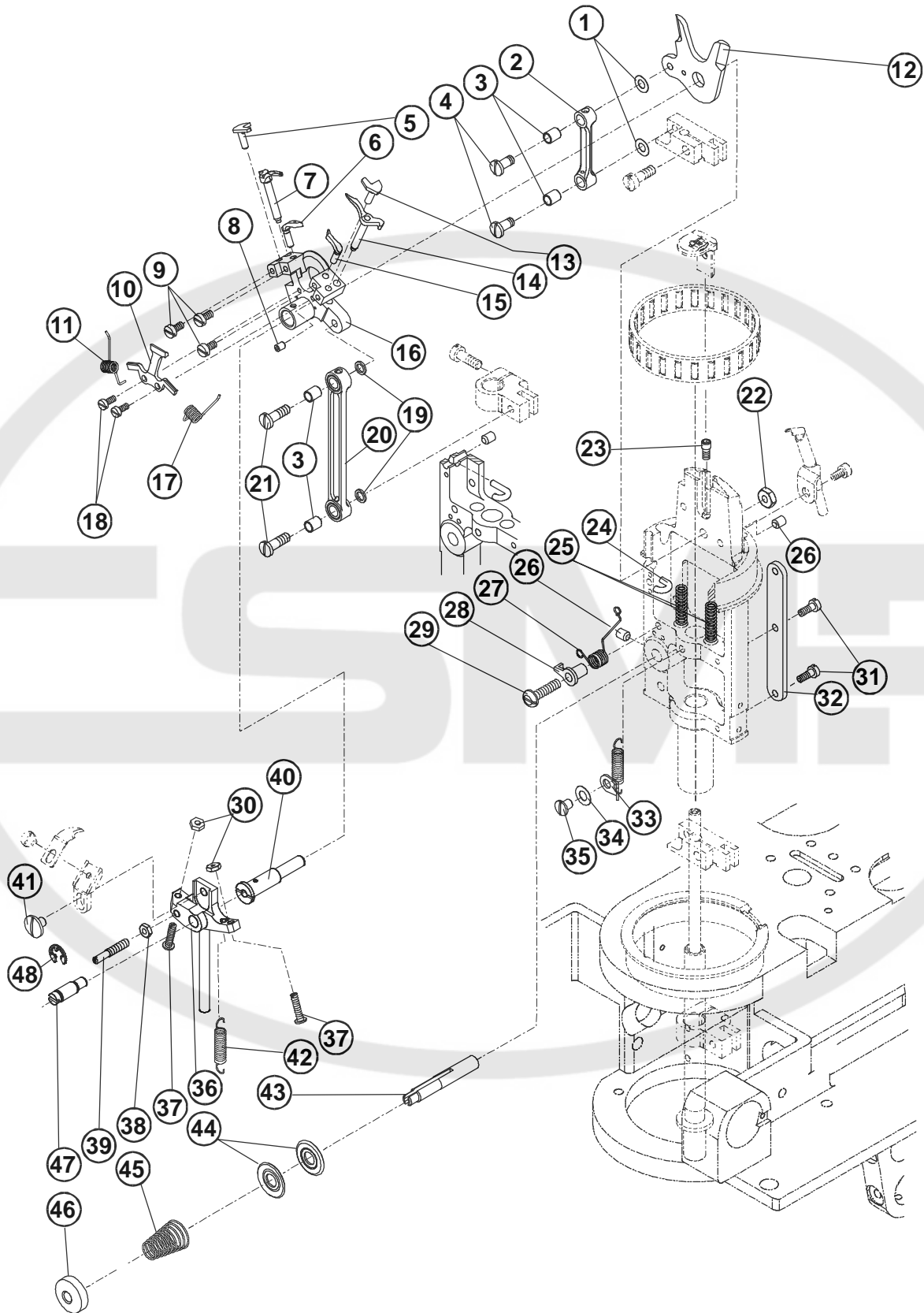

Revised 01/2007

E-mail: service@amfreece.cz; parts@amfreece.cz; website: www.amfreece.com

Phones: +420 582 309 146 (Service), +420 582 309 286 (Spare Parts); Fax: +420 582 360 606

RACE

DET	PART NUMBER	DESCRIPTION	QTY.
01	17.0019.0.228	Washer	2
02	19.0063.1.073	Spreader Link	1
03	17.0041.1.094	Roll	4
04	17.0012.1.140	Screw	2
05	19.0033.8.407	L.H. Spreader Stop	1
06	17.0069.4.049	Eye Looper 0,8	1
07	17.0004.9.895	Forked Spreader	1
08	08.6400.3.004	Screw	1
09	08.6010.3.005	Screw	3
10	10.4010.2.000	Needle Guard	1
11	01.5620.0.000	L.H. Spring	1
12	18.0081.8.706	Spreader Wedge	1
13	19.0033.8.408	R.H. Spreader Stop	1
14	17.0004.9.894	R.H. Spreader	1
15	17.0069.4.048	Blind Looper	1
16	19.0074.4.542	Looper Carrier	1
17	01.5619.0.000	R.H. Spring	1
18	17.0012.0.404	Screw	2
19	17.0019.1.088	Washer	2
20	17.0004.4.829	Looper Link	1
21	17.0012.1.142	Screw	2
22	08.6700.5.000	Nut	1
23	17.0012.2.400	Screw	1
24	19.0027.1.615	Thread Guide	1
25	17.0026.0.215	Spring	2
26	08.6400.4.005	Screw	2
27	17.0026.4.035	Spring	1
28	17.0064.7.162	Plate	1
29	08.6200.4.012	Screw	1
30	08.6700.3.000	Nut	2
31	08.6000.3.008	Screw	2
32	17.0081.5.082	Bracket	1
33	17.0082.5.235	Plate	1
34	08.6850.4.000	Washer	1
35	17.0012.4.105	Screw	1
36	19.0005.2.214	Lever	1
37	17.0013.6.081	Screw	2
38	17.0016.1.214	Nut	1
39	19.0011.0.400	Screw	1
40	19.0033.5.404	Looper Carrier Stud	1
41	17.0012.4.106	Screw	1
42	17.0026.3.173	Spring	1
43	19.0011.8.405	Stud	1
44	17.0082.8.083	Tension Plate	2
45	17.0026.2.400	Spring	1
46	17.0017.1.059	Nut	1
47	19.0033.1.405	Stud	1
48	12.1045.0.004	E-Clip	1

Revised 01/2007

E-mail: service@amfreece.cz; parts@amfreece.cz; website: www.amfreece.com

Phones: +420 582 309 146 (Service), +420 582 309 286 (Spare Parts); Fax: +420 582 360 606

STITCH SHAFT AND DRIVE

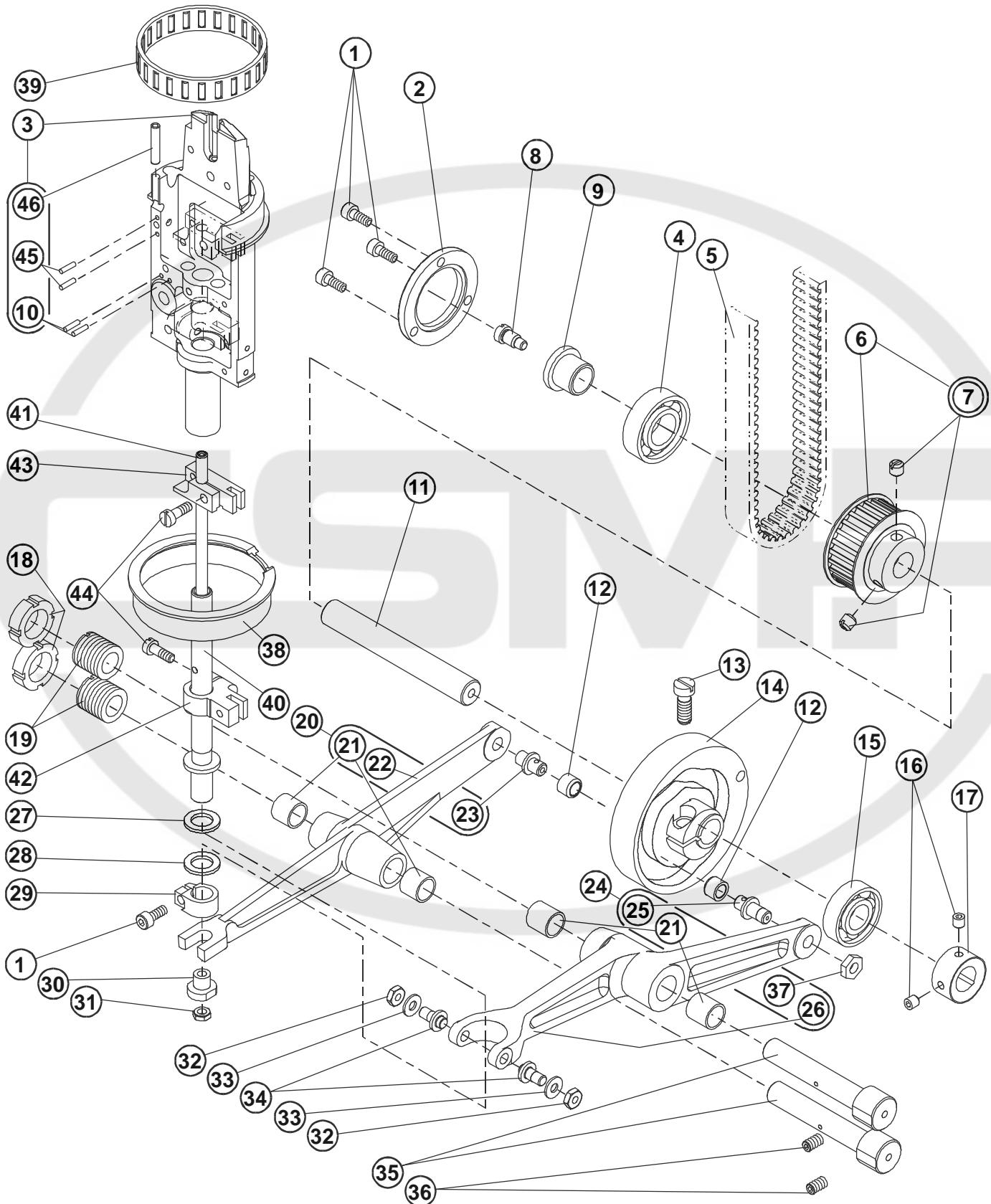

Revised 01/2007

E-mail: service@amfreece.cz; parts@amfreece.cz; website: www.amfreece.com
 Phones: +420 582 309 146 (Service), +420 582 309 286 (Spare Parts); Fax: +420 582 360 606

STITCH SHAFT AND DRIVE

DET	PART NUMBER	DESCRIPTION	QTY.
01	08.6000.4.010	Screw	4
02	19.0044.5.401	Flange	1
03	19.0071.7.404	Race	● 1
04	12.2010.0.021	Bushing	1
05	See Page 3-2	Timing Belt	—
06	19.0055.4.421	Gear	● 1
07	08.6400.6.006	Screw	(2)
08	17.0013.2.090	Screw	1
09	19.0042.2.400	Bushing	1
10	17.0031.0.406	Pin	(2)
11	19.0034.0.409	Shaft	1
12	19.0041.8.401	Roll	2
13	17.0012.0.113	Screw	1
14	19.0067.4.401	Cam	1
15	12.2010.0.011	Bushing	1
16	08.6400.5.305	Screw	2
17	17.0043.6.018	Set Screw Collar	1
18	19.0016.3.403	Nut	2
19	19.0013.6.400	Thread Insert	2
20	19.0063.6.442	Spreader Rocker	1
21	19.0041.0.693	Bushing	●● (4)
22	—————	Part Of Assembly Only 19.0063.6.442	● (1)
23	—————	Part Of Assembly Only 19.0063.6.442	(1)
24	19.0063.6.443	Lever, Looper	1
25	19.0033.3.401	Stud	(1)
26	—————	Part Of Assembly Only 19.0063.6.443	● (1)
27	19.0019.0.686	Washer	1
28	17.0019.0.398	Washer	1
29	19.0043.6.441	Looper Drive Shaft Collar	1
30	19.0041.2.404	Roll	1
31	17.0027.4.045	Ring Clip	1
32	08.6710.5.000	Nut	2
33	08.6850.5.000	Washer	2
34	17.0033.3.131	Stud	2
35	19.0032.6.401	Shaft	2
36	08.6400.5.008	Screw	2
37	17.0016.1.094	Nut	(1)
38	19.0042.1.406	Bushing	1
39	12.2050.0.008	Bushing	1
40	19.0034.6.402	Shaft	1
41	19.0034.6.403	Shaft	1
42	17.0074.4.405	Clamp	1
43	18.0064.6.427	Clamp	● 1
44	08.6010.4.012	Screw	2
45	19.0031.3.407	Pin	(2)
46	19.0084.1.613	Tube	(1)

Revised 01/2007

E-mail: service@amfreece.cz; parts@amfreece.cz; website: www.amfreece.com

Phones: +420 582 309 146 (Service), +420 582 309 286 (Spare Parts); Fax: +420 582 360 606

TURNING MECHANISM

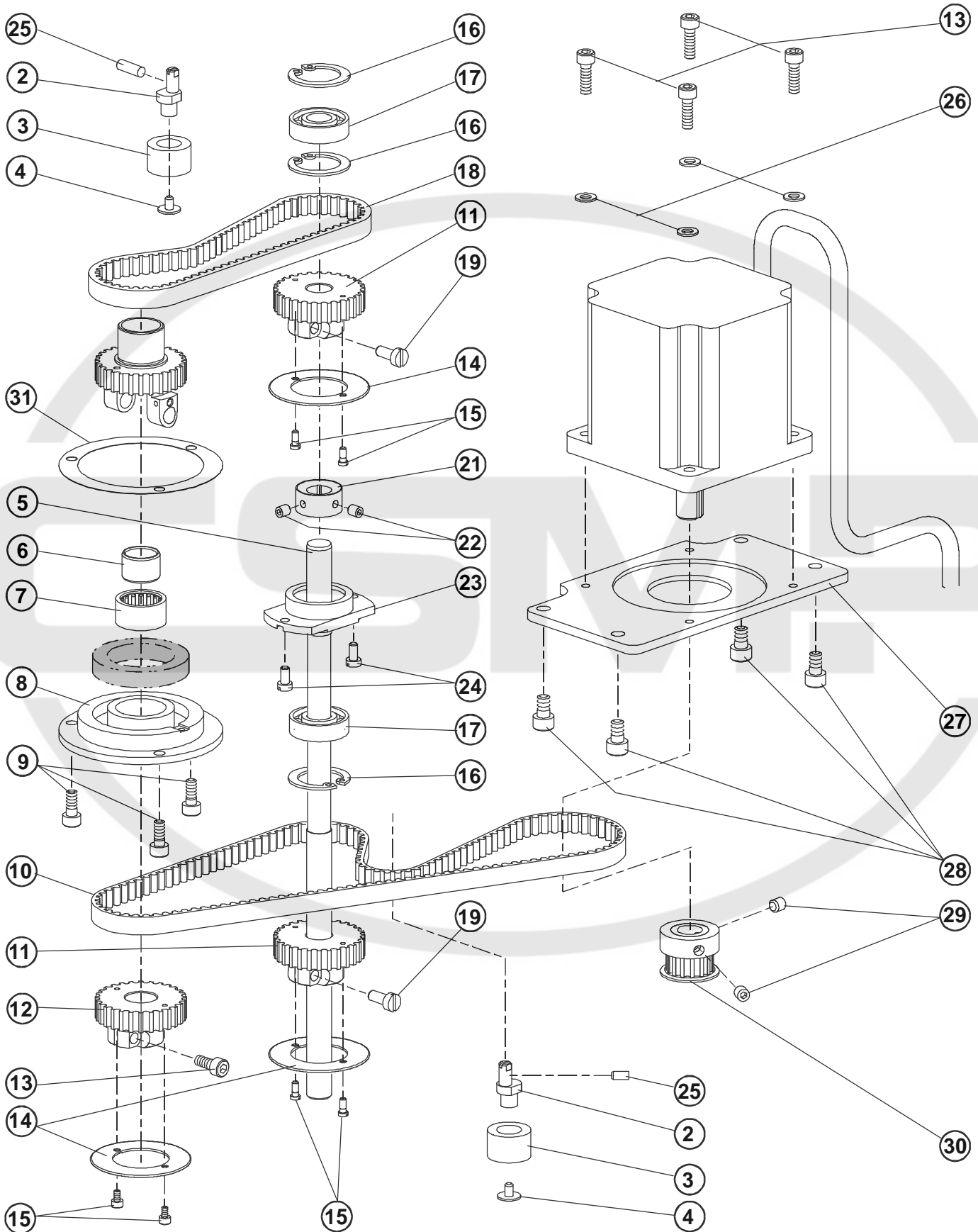

Revised 01/2007

E-mail: service@amfreece.cz; parts@amfreece.cz; website: www.amfreece.com
 Phones: +420 582 309 146 (Service), +420 582 309 286 (Spare Parts); Fax: +420 582 360 606

TURNING MECHANISM

DET	PART NUMBER	DESCRIPTION	QTY.
01			
02	19.0033.8.401	Tension Pulley Shaft	2
03	19.0041.0.683	Roll ●●●	2
04	17.0012.4.070	Screw	2
05	19.0034.1.401	Shaft	1
06	12.2099.1.009	Bearing	1
07	12.2050.1.007	Bearing	1
08	19.0042.5.401	Flange	1
09	08.6000.5.012	Screw	3
10	12.5050.2.013	Timing Belt ●●●	1
11	19.0055.4.407	Cear ●	2
12	19.0055.4.406	Gear ●	1
13	08.6000.5.016	Screw	5
14	19.0019.0.682	Washer	3
15	08.6000.3.005	Screw	6
16	12.1040.1.002	Retaining Ring	3
17	12.2010.0.011	Bearing	2
18	12.5050.2.006	Timing Belt ●●●	1
19	08.6010.5.016	Screw	2
21	17.0043.6.018	Set Screw Collar	1
22	08.6400.5.305	Screw	2
23	19.0044.5.402	Flange	1
24	17.0012.0.218	Screw	2
25	08.6400.4.008	Screw	2
26	08.6850.5.000	Washer	4
27	19.0081.5.461	Plate	1
28	08.6000.6.012	Screw	4
29	08.6400.6.006	Screw	2
30	19.0055.4.419	Gear Assembly ●	1
31	19.0019.6.405	Washer	2

Revised 01/2007

E-mail: service@amfreece.cz; parts@amfreece.cz; website: www.amfreece.com

Phones: +420 582 309 146 (Service), +420 582 309 286 (Spare Parts); Fax: +420 582 360 606

CUTTING LEVER ASSEMBLY

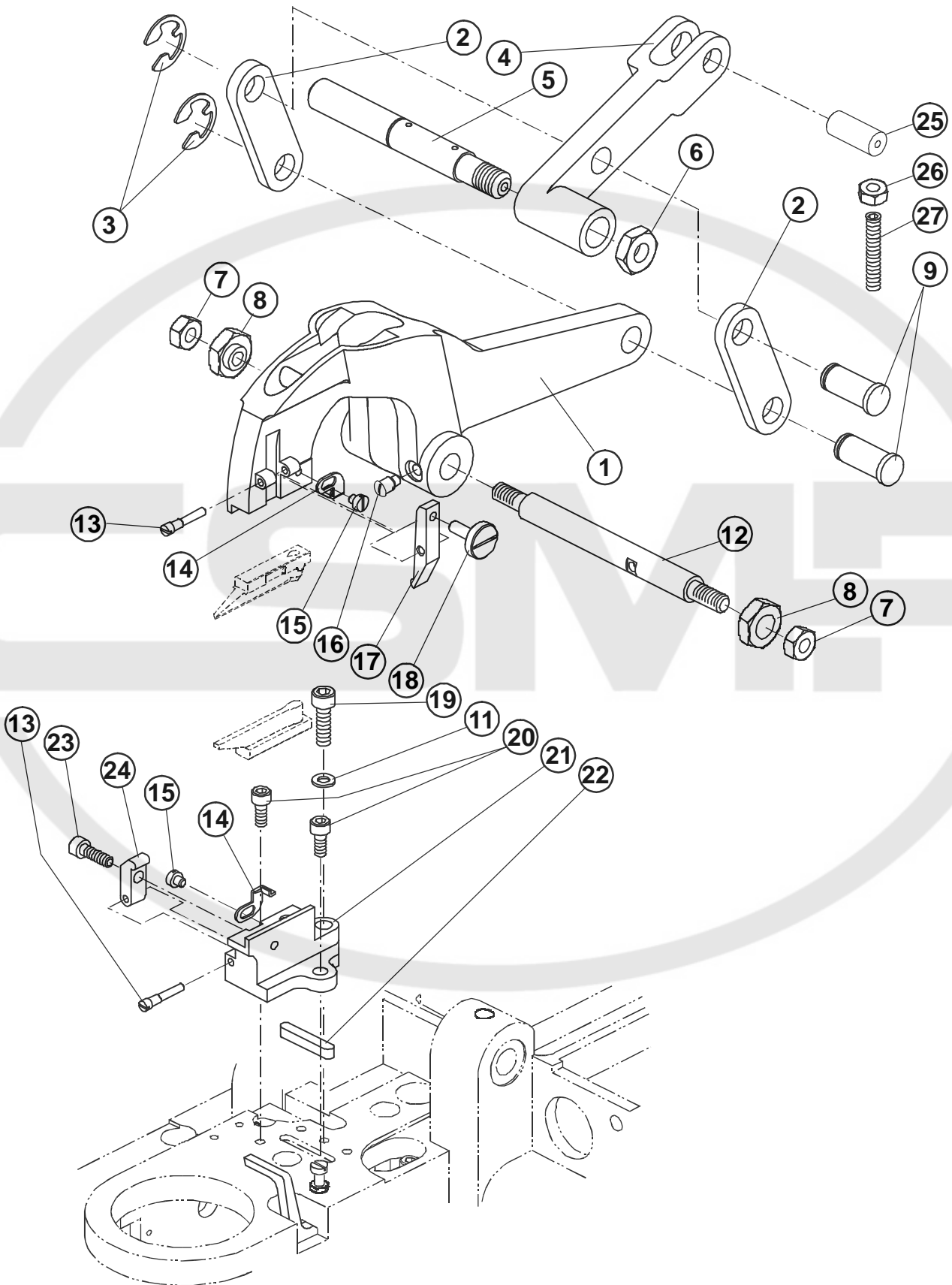

Revised 01/2007

E-mail: service@amfreece.cz; parts@amfreece.cz; website: www.amfreece.com
Phones: +420 582 309 146 (Service), +420 582 309 286 (Spare Parts); Fax: +420 582 360 606

CUTTING LEVER ASSEMBLY

DET	PART NUMBER	DESCRIPTION	QTY.
01	19.0063.5.416	Cutting Lever	1
02	19.0081.0.516	Draw Bar	2
03	12.1045.1.001	Retaining Ring	2
04	19.0063.5.417	Lever	1
05	19.0034.2.403	Shaft	1
06	08.6710.9.500	Nut	1
07	08.6710.8.400	Nut	2
08	19.0017.4.400	Nut	2
09	19.0032.8.405	Pivot	2
11	08.6850.5.000	Washer	1
12	19.0034.7.400	Shaft	1
13	17.0013.1.415	Screw	2
14	17.0082.5.997	Clamp	2
15	17.0012.0.571	Screw	2
16	17.0011.2.063	Screw	1
17	19.0063.6.456	Knife Holder	1
18	17.0013.4.027	Screw	1
19	08.6000.5.020	Screw	1
20	08.6000.5.012	Screw	2
21	19.0074.4.527	Knife Holder	1
22	17.0021.1.073	Key	1
23	08.6000.5.016	Screw	1
24	19.0063.6.445	Knife Clamp	1
25	19.0031.1.400	Pin	1
26	08.6700.5.000	Nut	1
27	08.6400.5.030	Screw	1

Revised 01/2007

E-mail: service@amfreece.cz; parts@amfreece.cz; website: www.amfreece.com

Phones: +420 582 309 146 (Service), +420 582 309 286 (Spare Parts); Fax: +420 582 360 606

KNIFE DRIVE

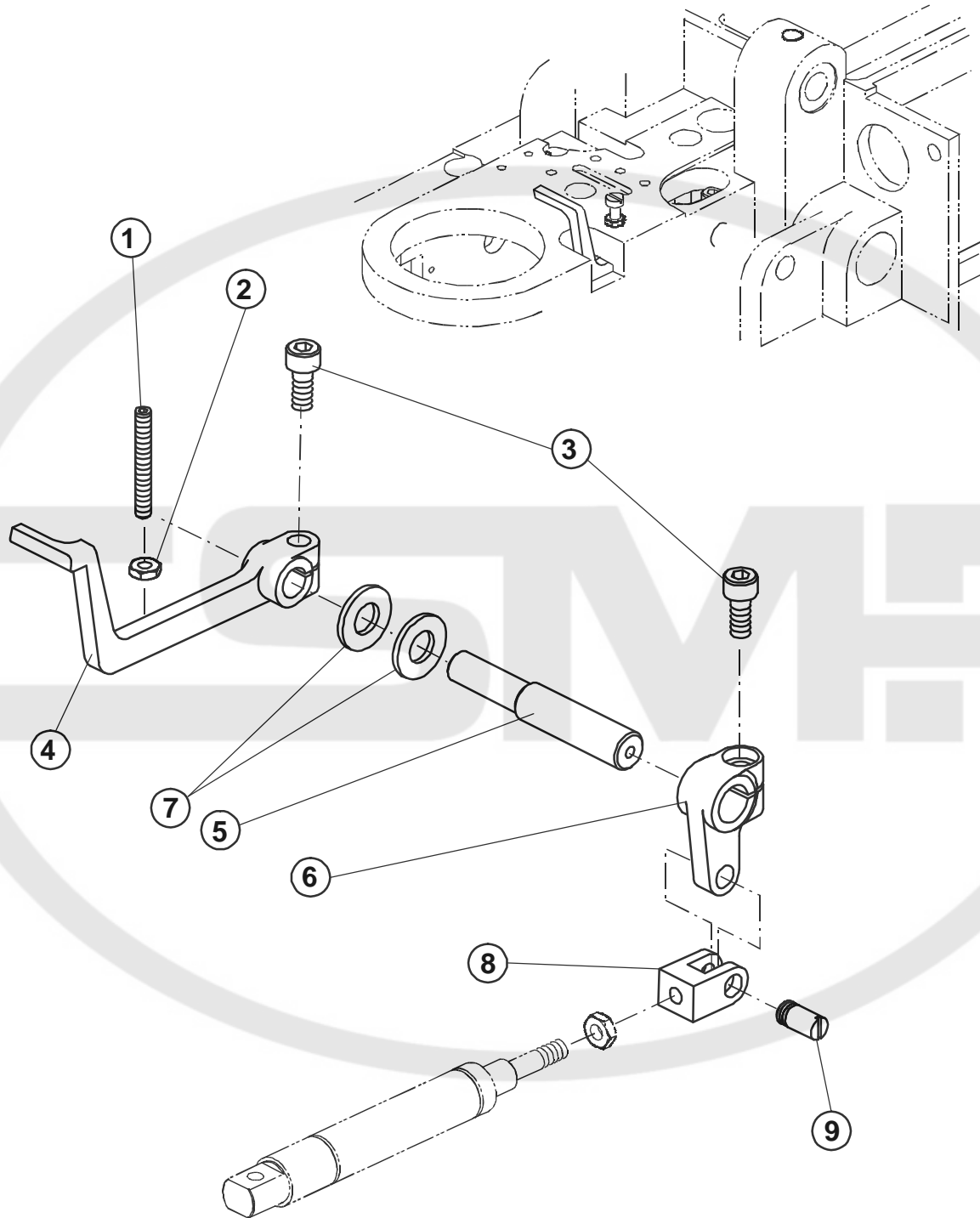

Revised 01/2007

E-mail: service@amfreece.cz; parts@amfreece.cz; website: www.amfreece.com

Phones: +420 582 309 146 (Service), +420 582 309 286 (Spare Parts); Fax: +420 582 360 606

LUBRICATION MECHANISM

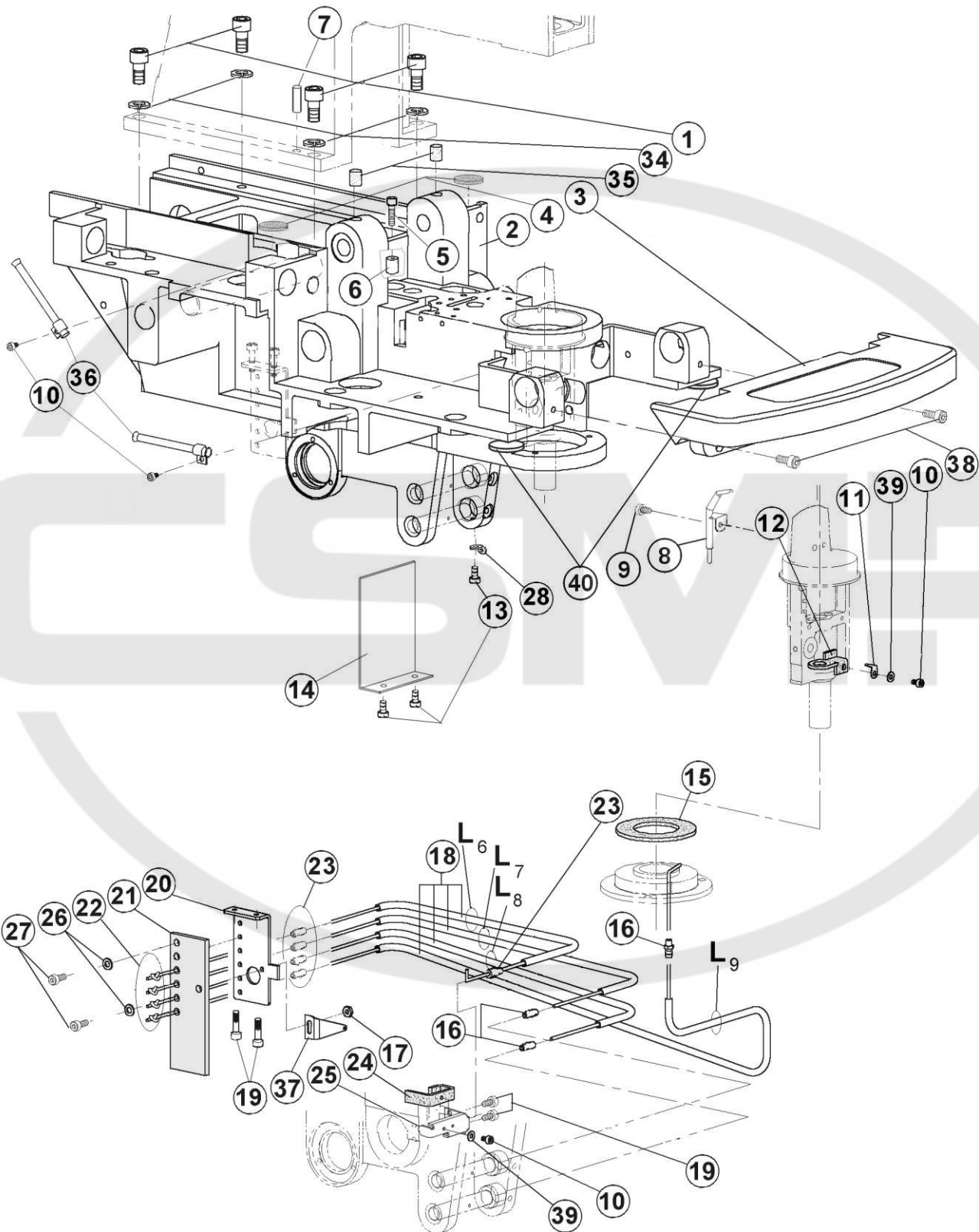

Revised 01/2007

E-mail: service@amfreece.cz; parts@amfreece.cz; website: www.amfreece.com

Phones: +420 582 309 146 (Service), +420 582 309 286 (Spare Parts); Fax: +420 582 360 606

LUBRICATION MECHANISM

DET	PART NUMBER	DESCRIPTION	QTY.
01	08.6000.8.020	Screw	4
02	19.0071.0.204	Base	1
03	19.0074.6.216	Cover	1
04	19.0094.5.413	Felt	2
05	08.6000.4.020	Screw	1
06	13.2087.1.000	Bumper	1
07	19.0031.8.414	Pin	2
08	19.0002.5.409	Guide Asembly	1
09	08.6010.4.010	Screw	1
10	08.6000.3.005	Screw	4
11	19.0082.3.411	Plate	1
12	19.0094.5.407	Felt	1
13	08.6200.4.008	Screw	3
14	19.0083.1.681	Cover	1
15	19.0094.5.406	Felt	1
16	19.0044.1.623	Nipple	3
17	08.6710.4.000	Nut	1
18	19.0094.2.412	Oil Tube L ₆ =220mm L ₇ =280mm L ₈ =265mm L ₉ =380mm	1
19	08.6000.4.005	Screw	4
20	19.0082.3.453	Plate	1
21	19.0094.5.405	Felt	1
22	19.0094.5.412	Wick L ₆ =360mm L ₇ =350mm L ₈ =420mm L ₉ =450mm	1
23	19.0094.2.409	Joint PM	5
24	19.0094.5.408	Felt	1
25	19.0082.3.450	Felt Holder	1
26	08.6850.4.000	Washer	2
27	08.6000.4.010	Screw	2
28	17.0027.1.106	Thread Guide	1
29			
30			
31			
32			
33			
34	08.6800.8.000	Spring Washer	4
35	17.0094.5.052	Felt	2
36	19.0002.5.411	Guide	2
37	05.0043.1.000	Bracket	1
38	08.6000.5.012	Screw	2
39	08.6850.3.000	Washer	2
40	19.0094.5.409	Felt	2

Revised 01/2007

E-mail: service@amfreece.cz; parts@amfreece.cz; website: www.amfreece.com

Phones: +420 582 309 146 (Service), +420 582 309 286 (Spare Parts); Fax: +420 582 360 606

CASE

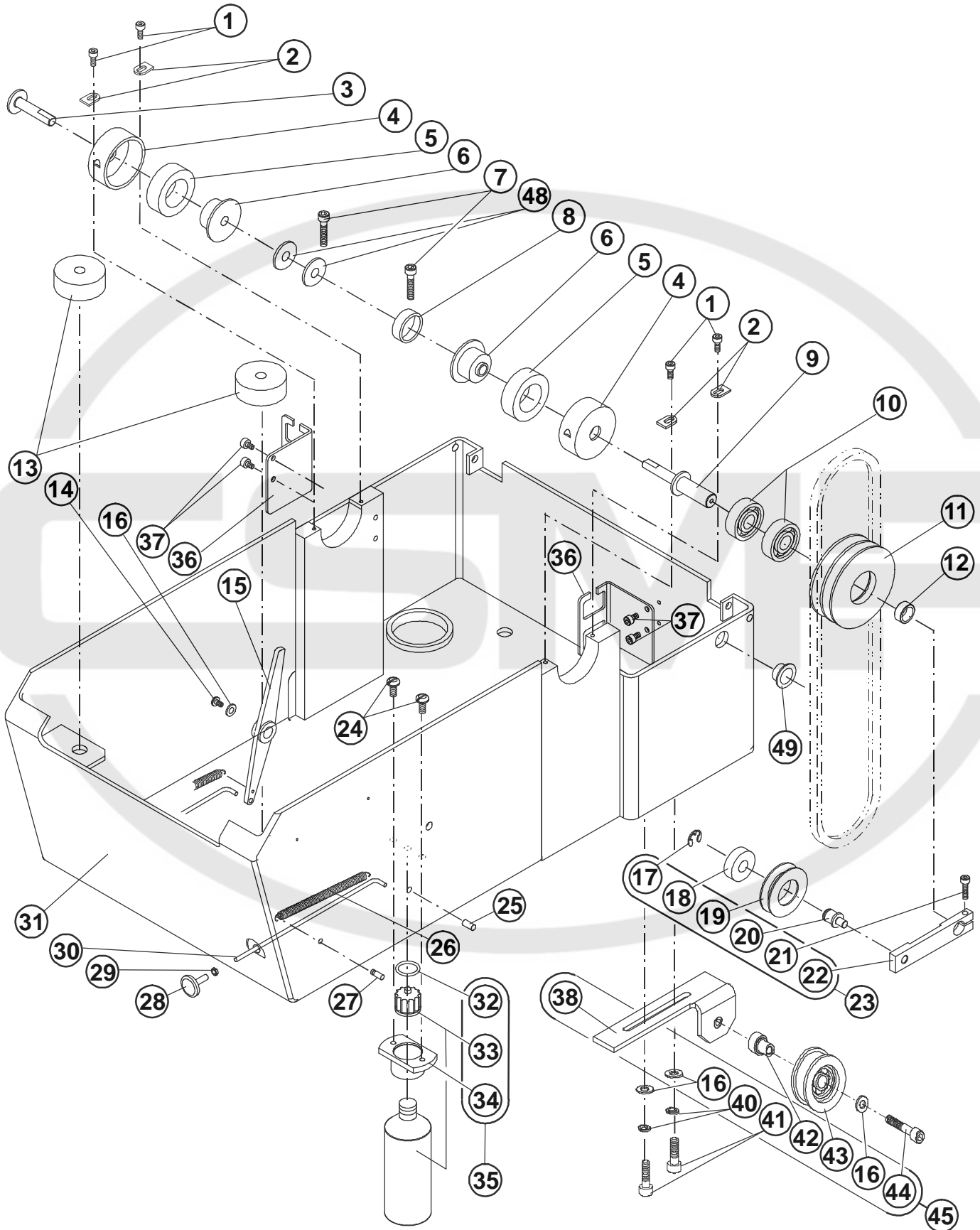

Revised 01/2007

E-mail: service@amfreece.cz; parts@amfreece.cz; website: www.amfreece.com
Phones: +420 582 309 146 (Service), +420 582 309 286 (Spare Parts); Fax: +420 582 360 606

CASE

DET	PART NUMBER	DESCRIPTION	QTY.
01	08.6000.4.010	Screw	4
02	17.0081.5.047	Latch	4
03	19.0032.2.407	Shaft Left	1
04	19.0041.6.400	Bushing ●●●	2
05	19.0094.1.400	Ring ●●●	2
06	19.0095.1.402	Bearing	2
07	08.6000.5.020	Screw ●●●	2
08	19.0041.0.694	Bushing	1
09	19.0032.3.401	Shaft	1
10	12.2010.0.005	Bearing	2
11	18.0052.1.400	Pulley ●	1
12	18.0041.0.676	Collar	1
13	19.0095.1.405	Rubber ●●●	2
14	08.6200.5.006	Screw	1
15	19.0063.3.403	Head Support	1
16	08.6850.6.000	Washer	(3)
17	17.0027.4.085	Retaining Ring	(1)
18	12.2010.0.004	Bearing	(1)
19	18.0052.0.274	Idler Pulley	(1)
20	18.0032.3.198	Idler Pulley Pin	(1)
21	08.6000.4.016	Screw	(1)
22	18.0061.3.350	Idler Pulley Lever	(1)
23	18.0004.3.251	Idler Pulley	1
24	08.6200.5.012	Screw	2
25	12.1010.0.525	Pin	1
26	17.0026.3.014	Spring	1
27	17.0031.0.196	Pin	1
28	19.0017.2.402	Pushbutton ●	1
29	08.6700.3.000	Nut	1
30	19.0027.1.603	Rod	1
31	19.0072.4.404	Case	1
32	12.0008.6.812	O Ring ●●●	(1)
33	05.1322.0.000	Oil Can ●●●	(1)
34	19.0044.5.404	Holder Oil Can	(1)
35	19.0008.2.001	Oil Can Assembly	1
36	19.0082.3.433	Holder	2
37	08.6000.4.005	Screw	4
38	04.9000.0.444	Holder Roller	1
40	08.6800.6.000	Spring Washer	(2)
41	08.6310.6.016	Screw	(2)
42	04.9000.1.443	Bushing	(1)
43	04.9001.0.001	Roller	(1)
44	08.6850.6.000	Washer	(1)
45	08.6000.6.030	Screw	(1)
46	04.9001.1.050	Left Roller Assembly	1
48	08.6850.8.000	Washer	2
49	17.0042.1.279	Thread Guide	1

Revised 01/2007

E-mail: service@amfreece.cz; parts@amfreece.cz; website: www.amfreece.com

Phones: +420 582 309 146 (Service), +420 582 309 286 (Spare Parts); Fax: +420 582 360 606

X-Y TABLE MOVEMENT

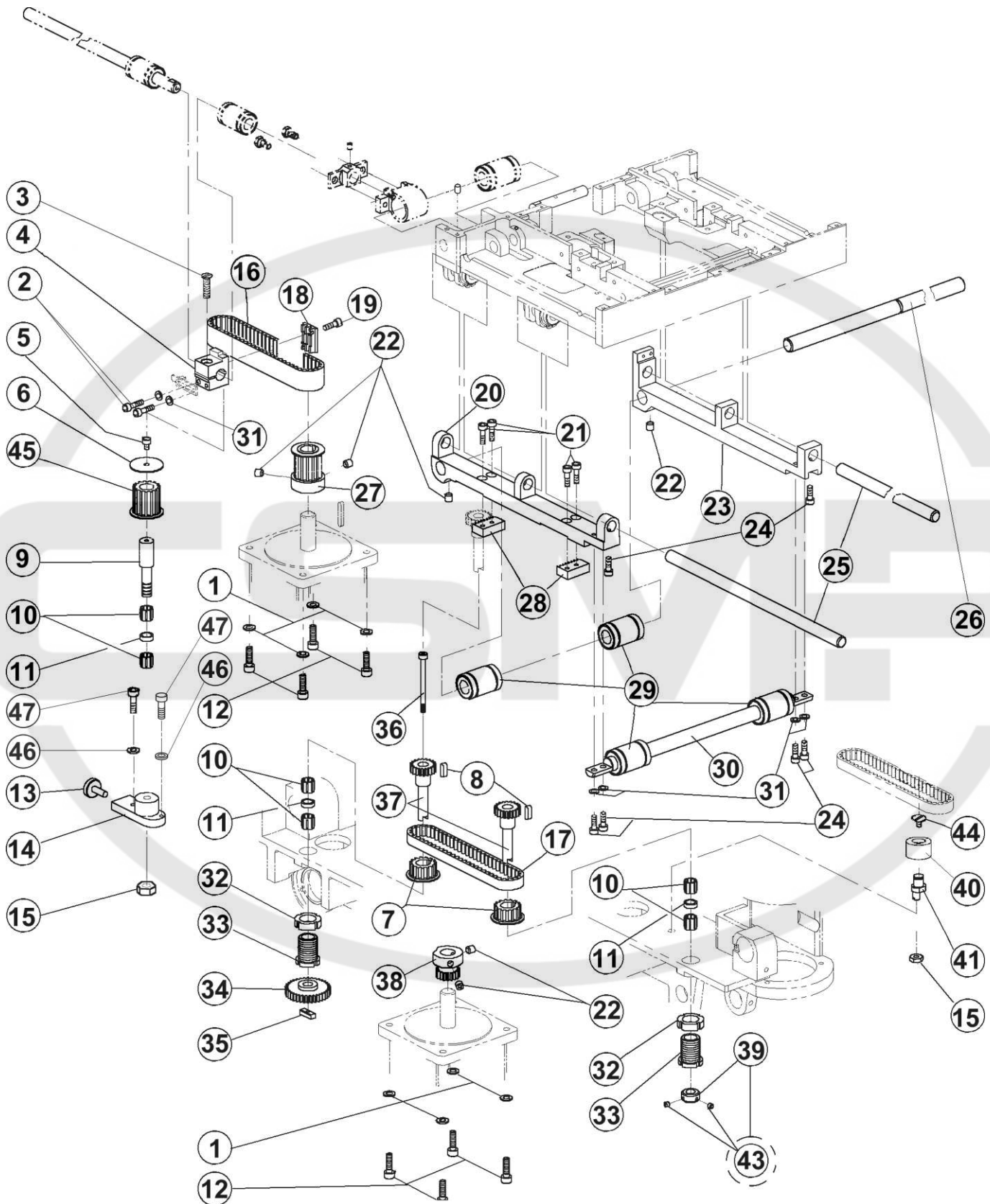

Revised 01/2007

E-mail: service@amfreece.cz; parts@amfreece.cz; website: www.amfreece.com

Phones: +420 582 309 146 (Service), +420 582 309 286 (Spare Parts); Fax: +420 582 360 606

X-Y TABLE MOVEMENT

DET	PART NUMBER	DESCRIPTION	QTY.
01	08.6850.5.000	Washer	8
02	08.6000.4.008	Screw	2
03	08.6100.5.020	Screw	1
04	19.0062.7.410	Shaft Holder ●	1
05	08.6000.4.006	Screw	1
06	19.0019.0.685	Washer	1
07	19.0055.4.408	Timing Belt Pulley	2
08	17.0021.1.069	Key	2
09	19.0033.5.403	Shaft	1
10	12.2050.0.007	Bearing	6
11	19.0041.0.675	Distance Ring	3
12	08.6000.5.016	Screw	8
13	17.0013.4.027	Screw	1
14	19.0064.8.448	Holder Press Pulley	1
15	08.6700.6.300	Nut	2
16	12.5050.2.014	Timing Belt ●●●	1
17	12.5050.2.005	Timing Belt Stock ●●●	1
18	19.0064.7.432	Belt Clamp ●	1
19	08.6000.4.010	Screw	2
20	19.0074.4.523	Holder Shaft Left ●	1
21	08.6000.4.014	Screw	4
22	08.6400.6.006	Screw	6
23	19.0074.4.536	Holder Shaft Right ●	1
24	08.6000.4.012	Screw	6
25	19.0034.0.403	Shaft	2
26	19.0034.0.401	Shaft	1
27	19.0055.4.425	Gear Assembly	1
28	19.0058.1.400	Rack	2
29	12.2070.0.004	Linear Ball Bearing	4
30	19.0034.0.402	Shaft	1
31	08.6850.4.000	Washer	6
32	19.0016.3.403	Nut	2
33	19.0015.6.401	Screw	2
34	19.0055.1.402	Gear	1
35	19.0016.3.405	Key	1
36	19.0012.2.401	Screw	1
37	19.0055.5.400	Gear	2
38	19.0055.1.403	Gear	1
39	19.0043.6.046	Shaft Collar	1
40	19.0041.0.683	Roll ●●●	1
41	19.0033.8.401	Tension Pulley Shaft	1
43	08.6400.4.004	Screw	(2)
44	17.0012.4.070	Screw	1
45	19.0055.4.424	Gear	1
46	08.6842.5.000	Washer	2
47	08.6200.5.020	Screw	2

Revised 01/2007

E-mail: service@amfreece.cz; parts@amfreece.cz; website: www.amfreece.com

Phones: +420 582 309 146 (Service), +420 582 309 286 (Spare Parts); Fax: +420 582 360 606

BED PLATE ASSEMBLY

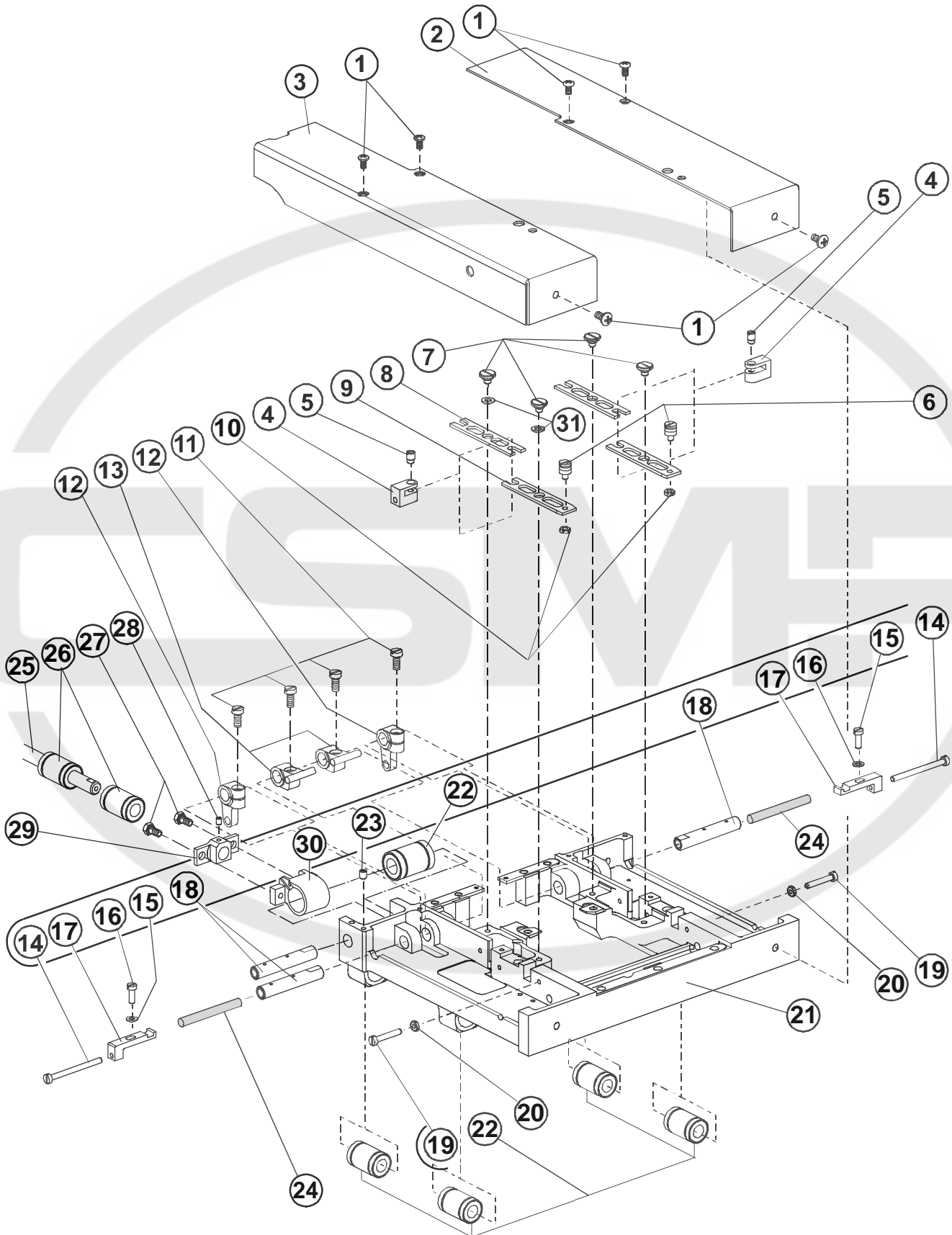

Revised 01/2007

E-mail: service@amfreece.cz; parts@amfreece.cz; website: www.amfreece.com
 Phones: +420 582 309 146 (Service), +420 582 309 286 (Spare Parts); Fax: +420 582 360 606

BED PLATE ASSEMBLY

DET	PART NUMBER	DESCRIPTION	QTY.
01	08.6522.4.006	Screw	6
02	19.0083.1.682	Plate	1
03	19.0083.1.683	Plate	1
04	19.0064.8.409	Knuckle	(2)
05	19.0033.1.406	Screw	(2)
06	19.0033.2.405	Screw	(2)
07	19.0013.1.487	Screw	(4)
08	19.0081.0.506	Fork	(2)
09	19.0081.0.505	Fork	(2)
10	19.0016.1.402	Nut	(2)
11	08.6010.5.012	Screw	(4)
12	19.0061.3.601	Lever	(2)
13	19.0063.6.441	Lever	(2)
14	08.6000.4.035	Screw	(2)
15	08.6010.4.012	Screw	(2)
16	08.6850.4.000	Washer	(2)
17	19.0064.7.405	Slide Adjust Plate	● (2)
18	19.0031.8.405	Shaft	(3)
19	08.6310.4.030	Screw	(3)
20	08.6710.4.000	Nut	(2)
21	19.0071.4.205	Bed Plate	(1)
22	07.0000.0.024	Linear Belt Pulley	● (5)
23	08.6400.5.006	Screw	(1)
24	19.0094.5.412	Felt	●●● 1
25	19.0034.0.404	Shaft	1
26	07.0000.0.024	Linear Ball Bearing	2
27	17.0014.1.119	Screw	2
28	17.0011.2.072	Screw	1
29	19.0064.8.407	Shaft Holder	1
30	19.0062.6.402	Line Pillow Block	● (1)
31	17.0019.0.228	Washer	2

Revised 01/2007

E-mail: service@amfreece.cz; parts@amfreece.cz; website: www.amfreece.com

Phones: +420 582 309 146 (Service), +420 582 309 286 (Spare Parts); Fax: +420 582 360 606

CLAMPING — AF

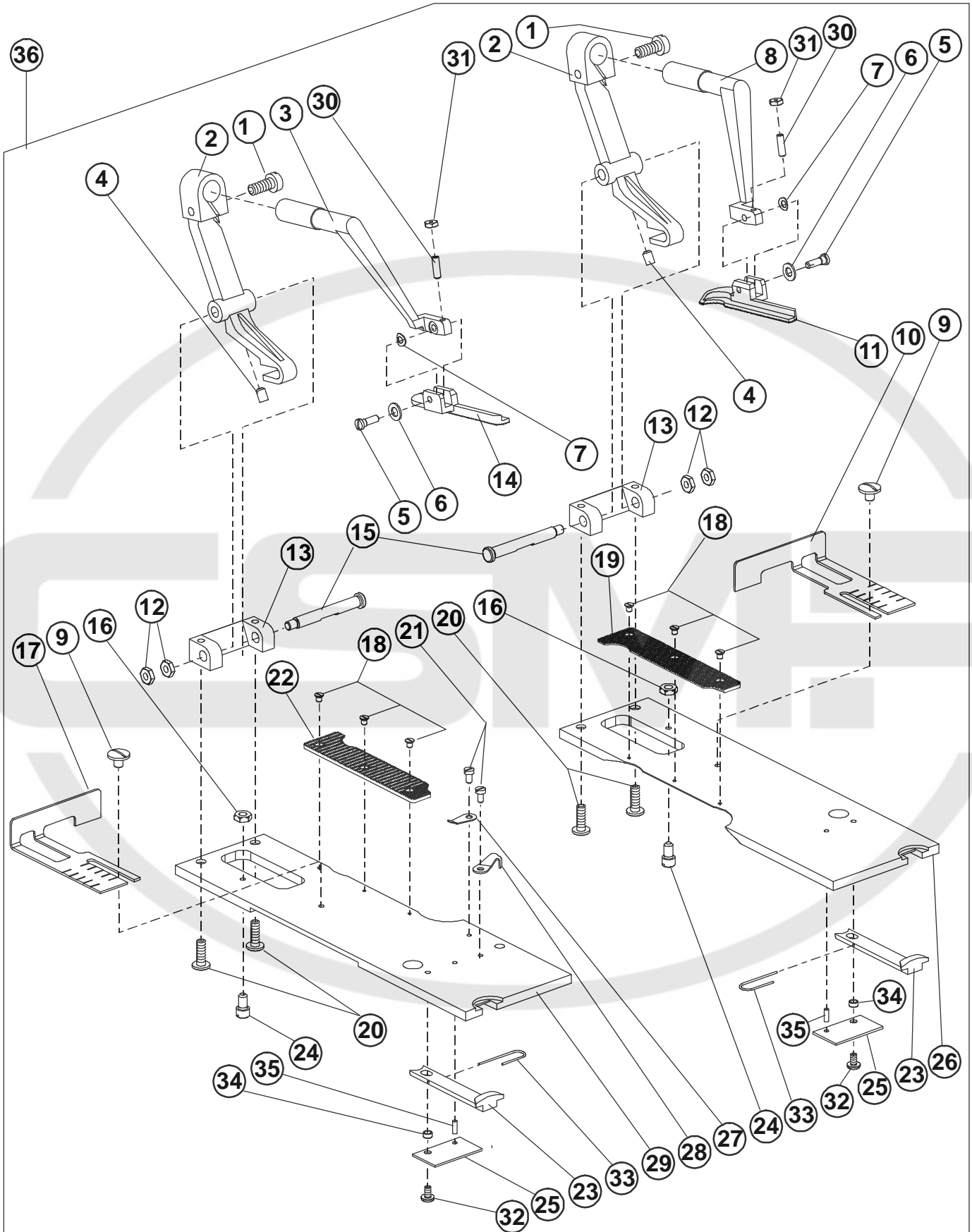

Revised 01/2007

E-mail: service@amfreece.cz; parts@amfreece.cz; website: www.amfreece.com
Phones: +420 582 309 146 (Service), +420 582 309 286 (Spare Parts); Fax: +420 582 360 606

CLAMPING — AF/ACL

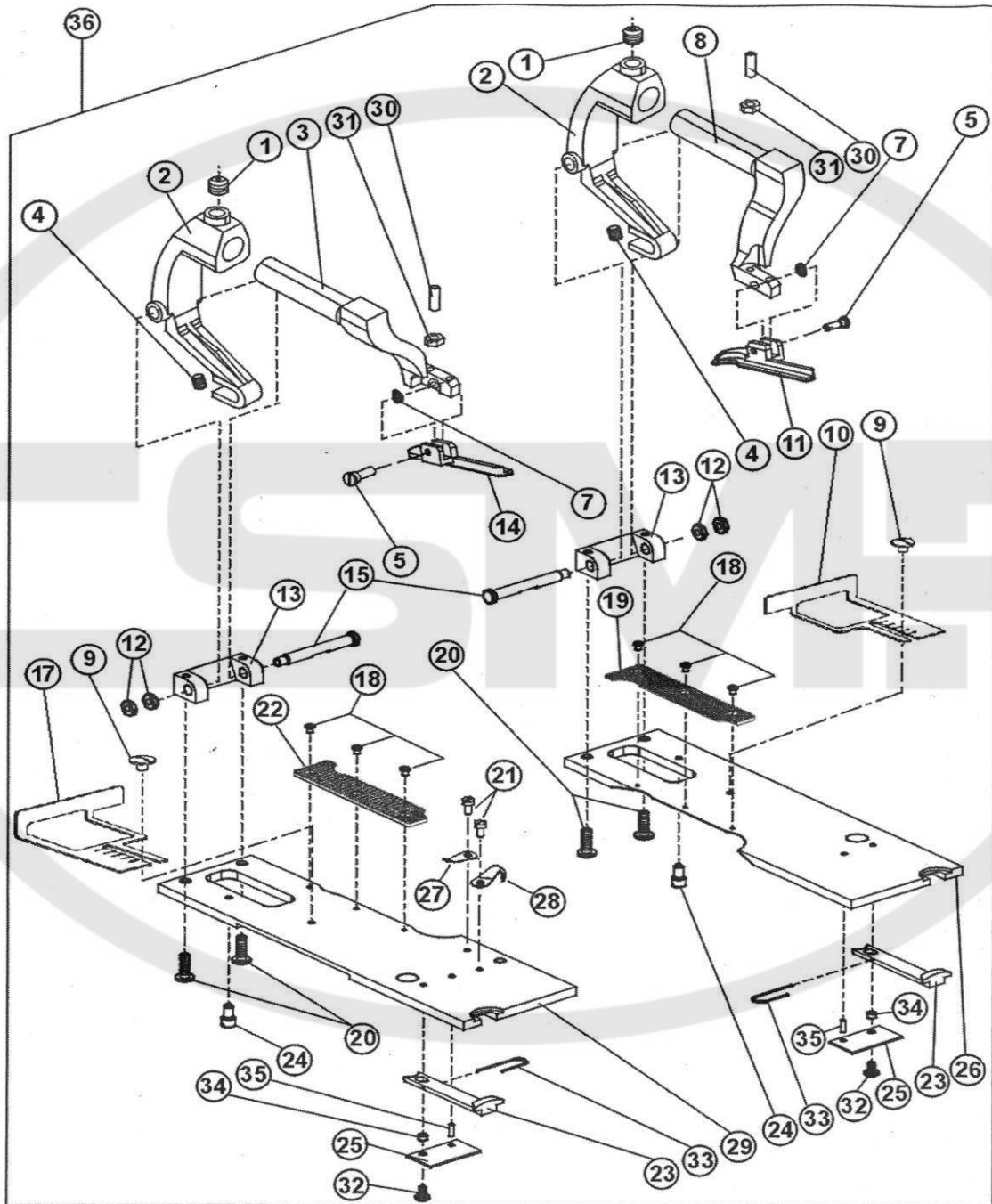

Revised 01/2007

E-mail: service@amfreece.cz; parts@amfreece.cz; website: www.amfreece.com
Phones: +420 582 309 146 (Service), +420 582 309 286 (Spare Parts); Fax: +420 582 360 606

COVERS

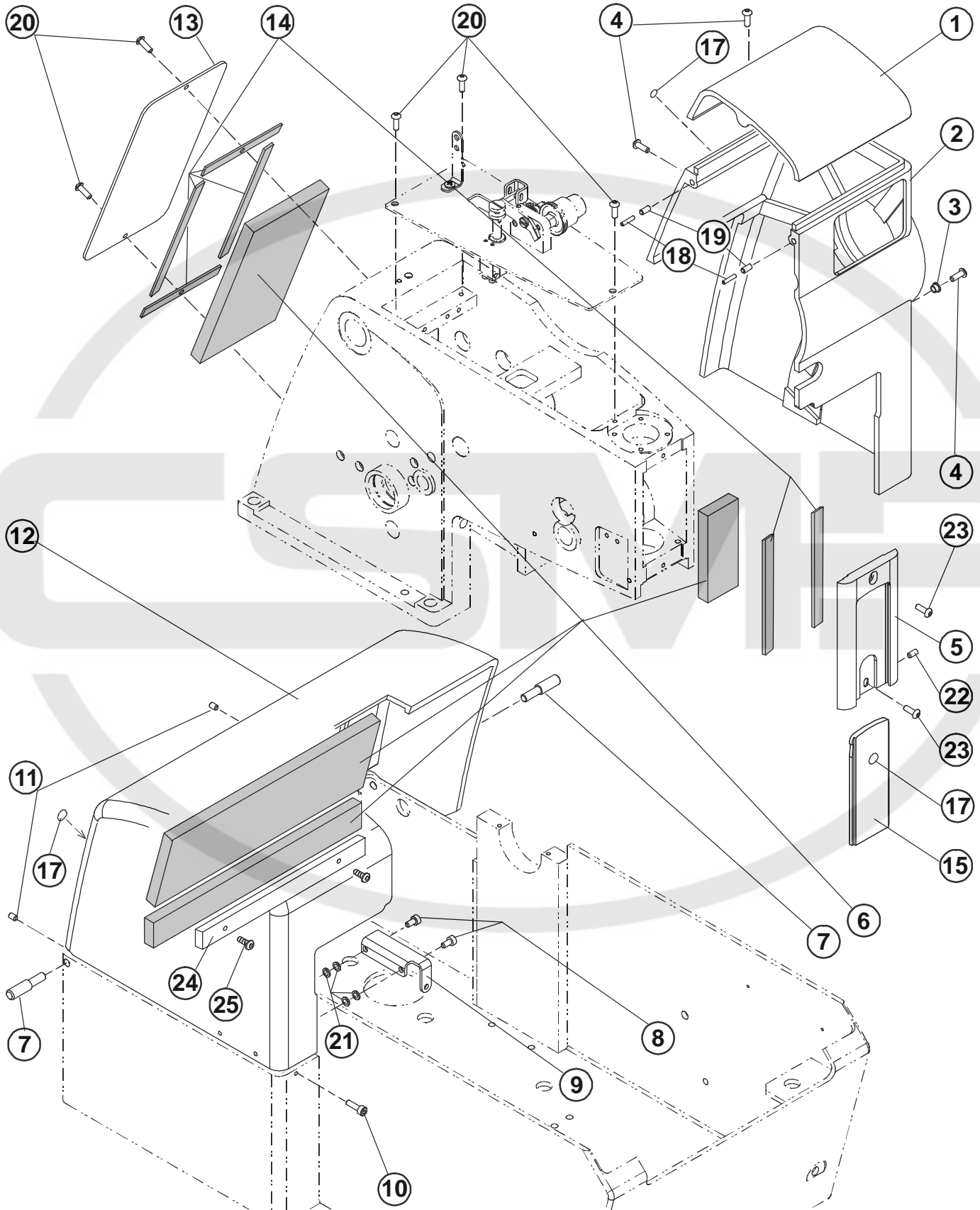

Revised 01/2007

E-mail: service@amfreece.cz; parts@amfreece.cz; website: www.amfreece.com

Phones: +420 582 309 146 (Service), +420 582 309 286 (Spare Parts); Fax: +420 582 360 606

COVERS

DET	PART NUMBER	DESCRIPTION	QTY.
01	19.0074.6.225	Stitch Drive Cover ●	1
02	19.0075.4.404	Control Panel Cover ●	1
03	19.0095.1.408	Ring	1
04	08.6000.4.010	Screw M4x12	3
05	19.0074.6.227	Front Cover ●	1
06	19.0095.3.405	Sound Suppressor Kit ●●●	1
07	19.0031.3.405	Screw	2
08	08.6000.4.008	Screw M4x8	2
09	19.0083.4.021	Shim	1
10	08.6000.4.014	Screw M4x14	1
11	08.6400.4.006	Screw M4x6	2
12	19.0074.6.226	Cover ●	1
13	19.0081.5.460	Arm Cover	1
14	19.0094.0.414	Gasket Cover ●●●	1
15	19.0095.4.403	Cover	1
17	12.0008.6.915	Support	3
18	12.1010.0.320	Pin	2
19	19.0094.2.413	Tube L ₁₀ = 12 mm (2x)	-
20	08.6032.4.008	Screw	6
21	08.6850.4.000	Washer	4
22	08.6400.3.005	Screw	1
23	08.6200.4.008	Screw	1
24	19.0081.5.454	Cover Back	1
25	08.6000.4.005	Screw	2

Revised 01/2007

E-mail: service@amfreece.cz; parts@amfreece.cz; website: www.amfreece.com

Phones: +420 582 309 146 (Service), +420 582 309 286 (Spare Parts); Fax: +420 582 360 606

HEAD PNEUMATIC PARTS STANDARD

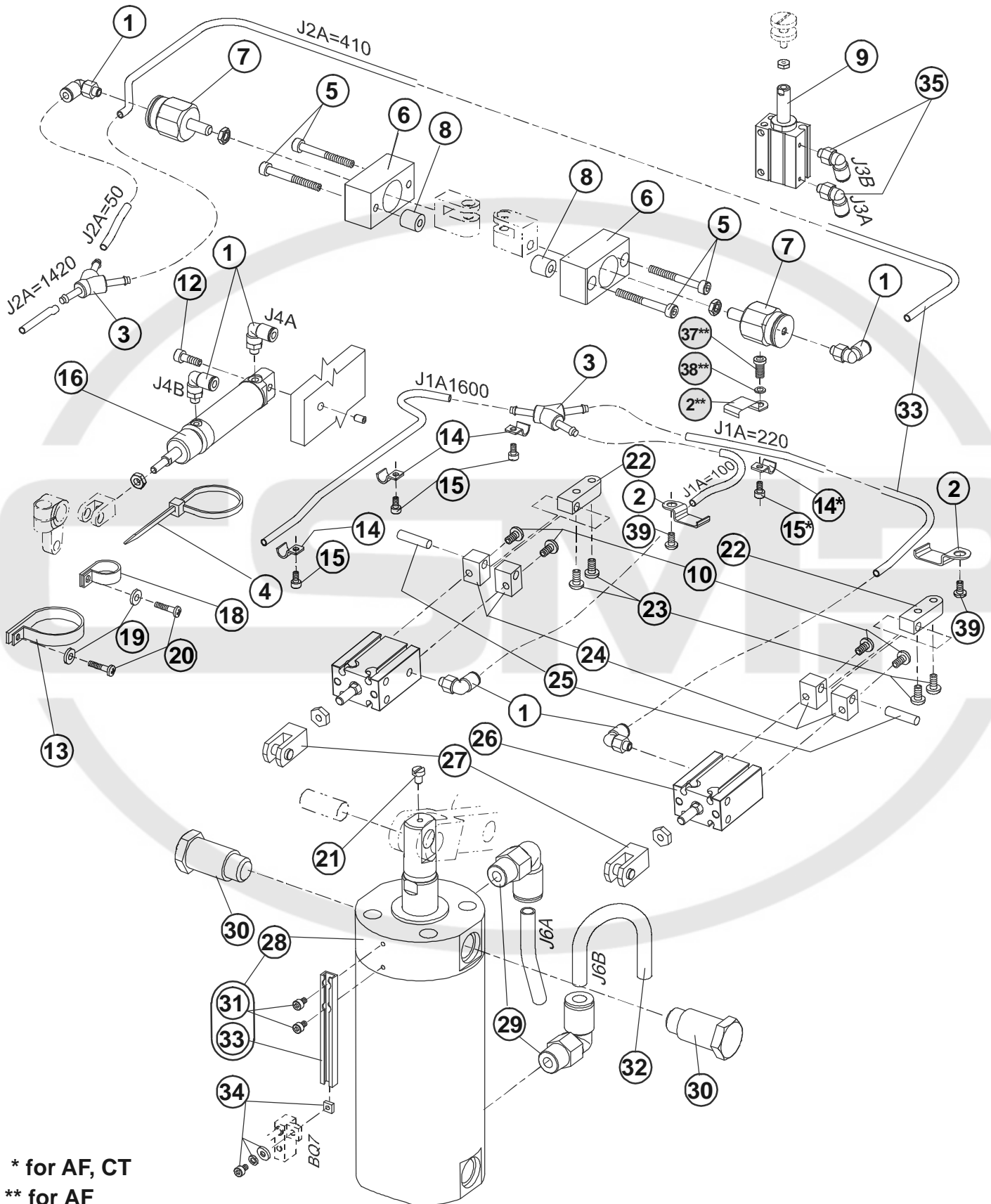

* for AF, CT

** for AF

Revised 01/2007

E-mail: service@amfreece.cz; parts@amfreece.cz; website: www.amfreece.com

Phones: +420 582 309 146 (Service), +420 582 309 286 (Spare Parts); Fax: +420 582 360 606

HEAD PNEUMATIC PARTS STANDARD

DET	PART NUMBER	DESCRIPTION	QTY.	
01	12.0008.3.411	Connector	6	
02**	19.0082.6.434	Clamp	3	
03	12.0008.3.090	Connector	2	
04	12.0008.3.023	Ty-wrap	13	
05	08.6000.4.025	Screw	4	
06	19.0064.8.445	Valve Holder	2	
07	12.0008.3.734	Cylinder	2	
08	19.0041.0.690	Roll	2	
09	12.0008.3.631	Cylinder	1	
10	08.6000.4.016	Screw M4x16	4	
11				
12	19.0033.2.411	Stud	1	
13	12.0008.4.197	Cord Clamp	1	
14*	17.0082.6.000	Clamp	4	
15*	08.6000.3.006	Screw	4	
16	12.0008.3.764	Cylinder	1	
17	08.6700.4.000	Nut	1	
18	12.0008.4.100	Cord Clamp	1	
19	08.6850.4.000	Washer	2	
20	08.6000.4.010	Screw	2	
21	08.6010.4.006	Screw	1	
22	19.0062.6.403	Holder	2	
23	08.6200.4.008	Screw	4	
24	19.0064.8.444	Cylinder Holder	4	
25	12.1010.0.530	Pin 5x20	2	
26	12.0008.3.733	Cylinder	2	
27	12.0008.3.739	Knuckle	2	
28	19.0008.3.412	Cylinder	1	
29	12.0008.3.741	Connector	2	
30	19.0014.3.405	Shaft	2	
31	08.6000.3.006	Screw	(2)	
32	19.0094.2.417	Air Tubing 4x0,75 Air Tubing 8x1,25	J1A=1600/220/100/30 J2A=1420/410/50 J3A=1510/30 J3B=1600 J4A=1520 / J4B=1470 J7A=1770 (LTT) / 1900 (CT) J7B = 1780 (LTT) J0A=185/200 J6A=1550 J6B=1530	●●● 1
33	19.0008.3.414	Switch Rail	(1)	
34	12.0008.3.412	Rail Stopper	1	
35	12.0008.3.746	Connector	1	
36				
37**	08.6000.3.008	Screw	1	
38**	08.6850.3.000	Washer	1	
39	08.6000.4.005	Screw	2	

* — for AF, CT

** — for AF

Revised 01/2007

E-mail: service@amfreece.cz; parts@amfreece.cz; website: www.amfreece.com

Phones: +420 582 309 146 (Service), +420 582 309 286 (Spare Parts); Fax: +420 582 360 606

CONTROL BOX — PNEUMATIC PARTS

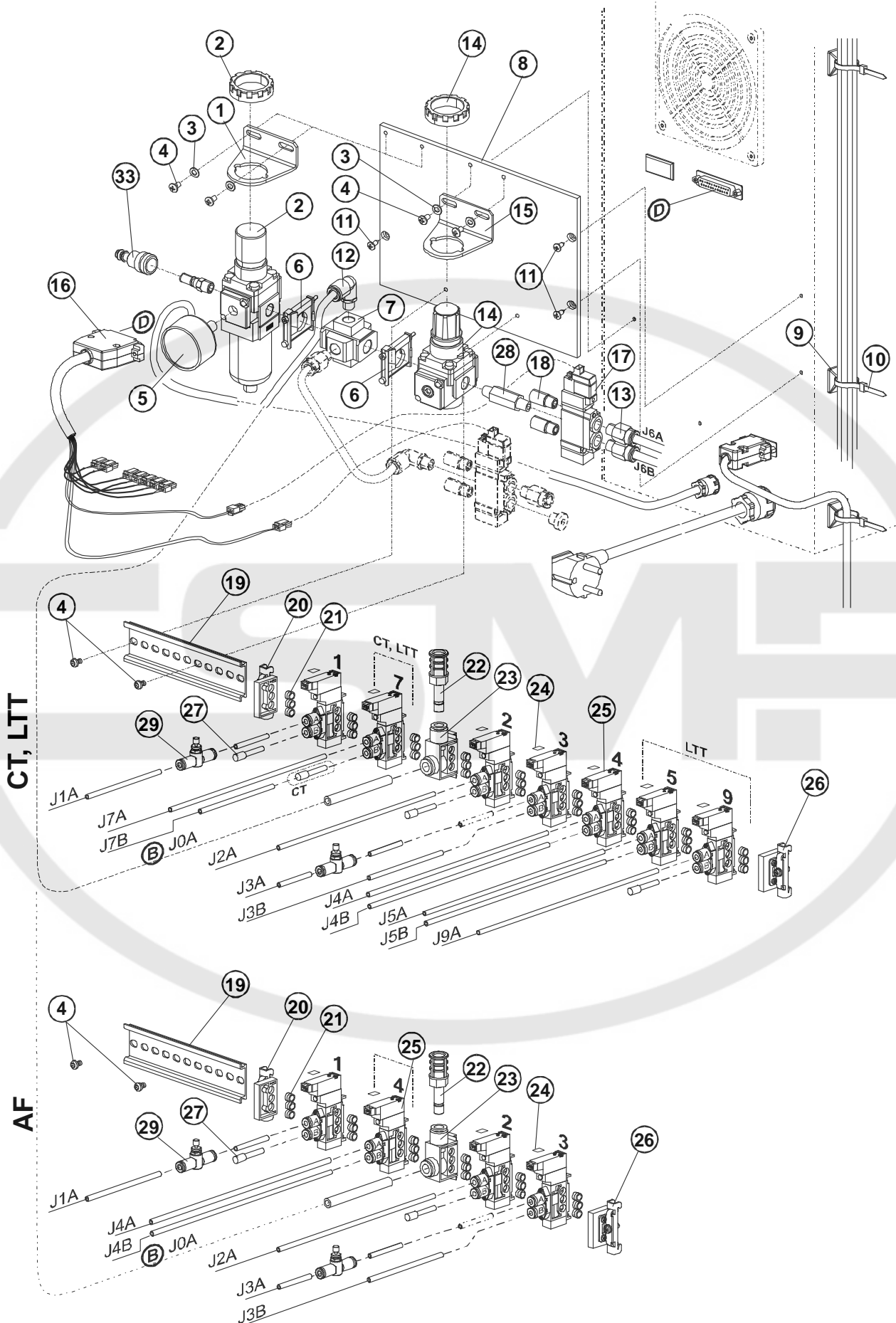

Revised 01/2007

E-mail: service@amfreece.cz; parts@amfreece.cz; website: www.amfreece.com

Phones: +420 582 309 146 (Service), +420 582 309 286 (Spare Parts); Fax: +420 582 360 606

CONTROL BOX — PNEUMATIC PARTS

DET	PART NUMBER	DESCRIPTION	QTY.
01	12.0008.3.659	Regular Holder	1
02	12.0008.3.753	Regulator	1
03	08.6852.4.000	Washer	4
04	08.6032.4.008	Screw	6
05	12.0008.3.418	Pressure Gauge	1
06	12.0008.3.756	Spacer	2
07	12.0008.3.755	Cross Spacer	1
08	19.0008.3.416	Plate	1
09	12.0008.4.058	Clip	4
10	12.0008.3.023	Tie-wrap ●●●	4
11	08.6683.4.007	Screw	3
12	12.0008.3.754	Connector	1
13	12.0008.3.421	Connector	2
14	19.0082.3.757	Regulator	1
15	12.0008.3.762	Regular Holder	1
16	19.0007.9.483	Cable Valve	1
17	12.0008.3.759	Pneumatic Valve	1
18	12.0008.3.427	Silencer	2
19	12.0008.3.760	DIN Rail	1
20	12.0008.3.478	Rail Stopper	1
21	12.0008.3.477	Connector	24
22	12.0008.3.483	Silencer	1
23	12.0008.3.479	Air Supply Block Assembly	1
24	—	Labels Kit	—
25	12.0008.3.482	Pneumatic Valve	4+3
26	12.0008.3.476	Rail Stopper	1
27	12.0008.3.426	Plug ●●●	4
28	12.0008.3.758	Spacer	1
29	12.0008.3.430	Speed Controller	2
30			
31	19.0094.2.417	Air Tubing 4x0,75 J1A=1600/220/100/30 J2A=1420/410/50 J3A=1510/30 J3B=1600 J4A=1520 / J4B=1470 J7A=1770 (LTT) / 1900 (CT) J7B = 1780 (LTT) Air Tubing 8x1,25 J0A=185/200 J6A=1550 J6B=1530	●●● (1)
32	12.0008.3.420	Connector	1
33	See Page 3-77	Connector	—

Revised 01/2007

E-mail: service@amfreece.cz; parts@amfreece.cz; website: www.amfreece.com

Phones: +420 582 309 146 (Service), +420 582 309 286 (Spare Parts); Fax: +420 582 360 606

EXHAUST -PNEUMATIC PARTS

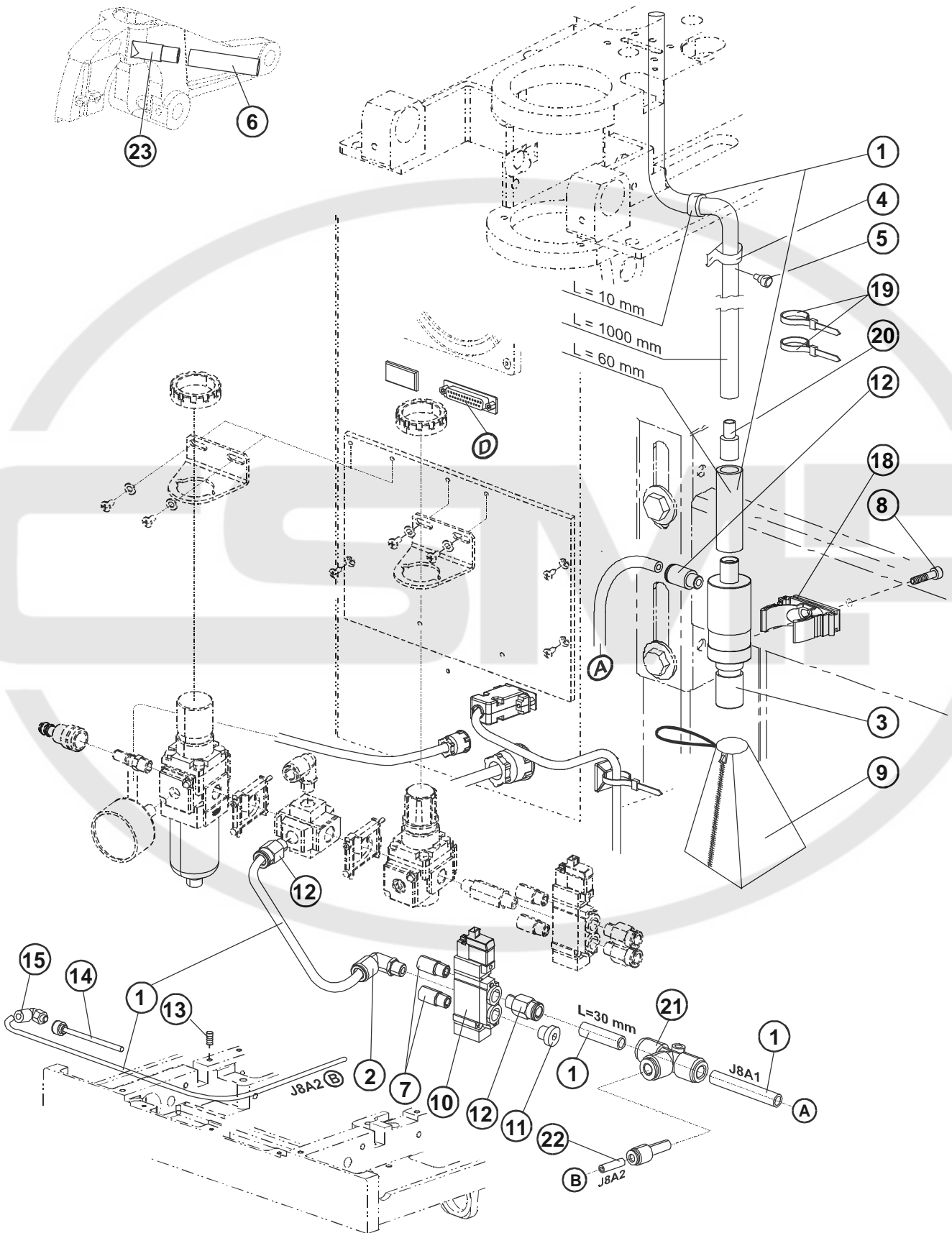

Revised 01/2007

E-mail: service@amfreece.cz; parts@amfreece.cz; website: www.amfreece.com

Phones: +420 582 309 146 (Service), +420 582 309 286 (Spare Parts); Fax: +420 582 360 606

EXHAUST - PNEUMATIC PARTS

DET	PART NUMBER	DESCRIPTION	QTY.
01	19.0094.2.417	Air Tubing 4x0,75 J8A2=1880 mm Air Tubing 8x1 J8A1=290 mm J8A1=30 mm Air Tubing 19x4 J8A1=10 mm J8A1=60 mm	1
02	12.0008.3.754	Connector	1
03	19.0008.3.415	Vacuum Unit	(1)
04	07.6600.0.006	Clamp, Cable	(1)
05	08.6200.5.006	Screw M5x6	(1)
06	19.0094.2.418	Air Tubing 12x2 L= 1000 mm	1
07	12.0008.3.427	Silencer	2
08	08.6000.5.022	Screw	1
09	12.0008.6.977	Bag	1
10	12.0008.3.759	Valve	1
11	12.0008.3.428	Plug	1
12	12.0008.3.421	Connector	2
13	08.6400.4.006	Screw M4x6	1
14	19.0005.2.218	Tube	1
15	12.0008.3.411	Connector	1
18	12.0008.6.980	Sleeve 32	1
19	12.0008.3.023	Tie-wrap	2
20	19.0084.1.614	Pipe	1
21	12.0008.3.689	Connector	1
22	12.0008.3.447	Connector	1
23*	19.0031.4.401	insert	(1)

* for LTT/ACL

Revised 01/2007

E-mail: service@amfreece.cz; parts@amfreece.cz; website: www.amfreece.com

Phones: +420 582 309 146 (Service), +420 582 309 286 (Spare Parts); Fax: +420 582 360 606

HEAD ELECTRONIC PARTS

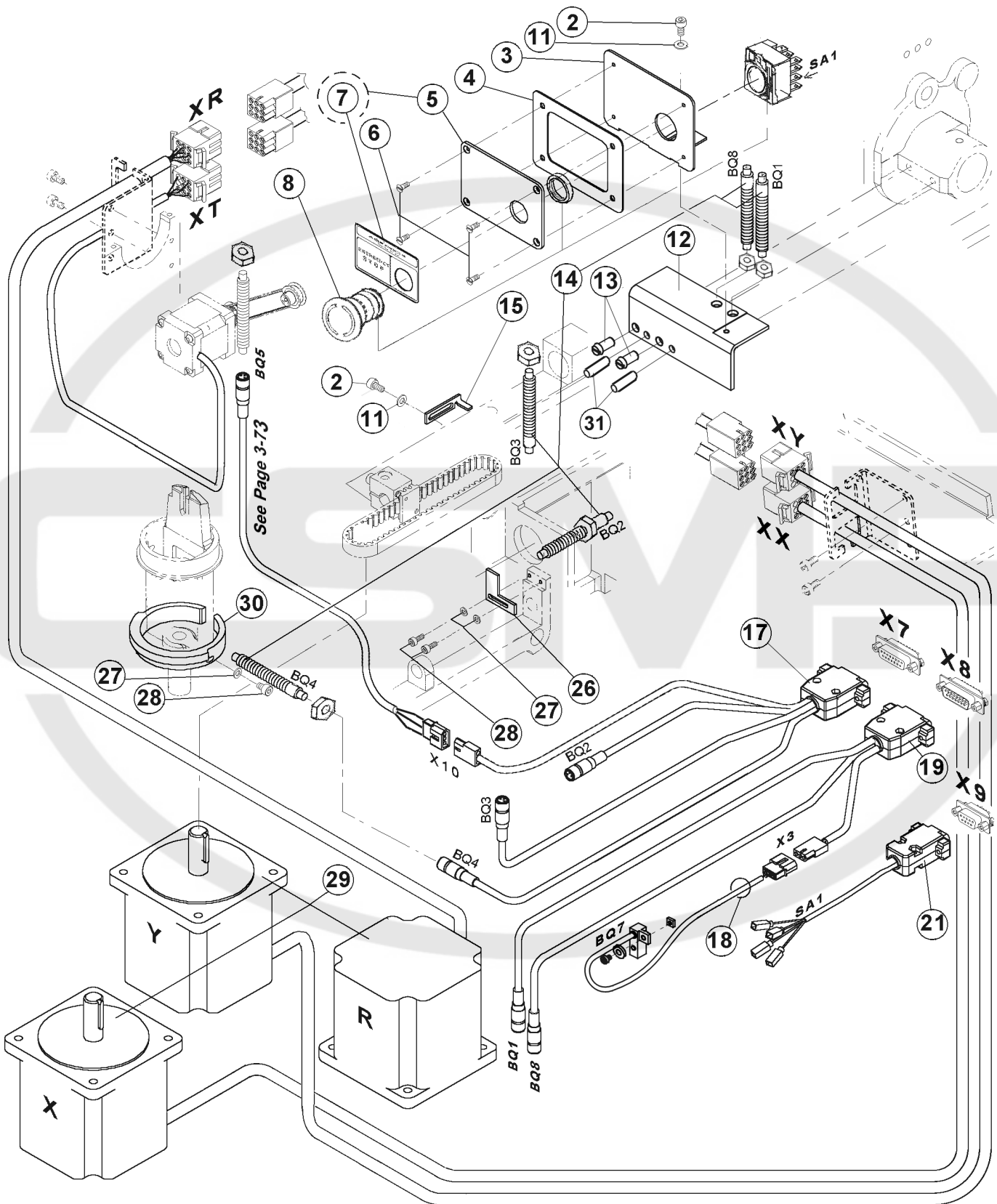

See Page 3-73

TABLE

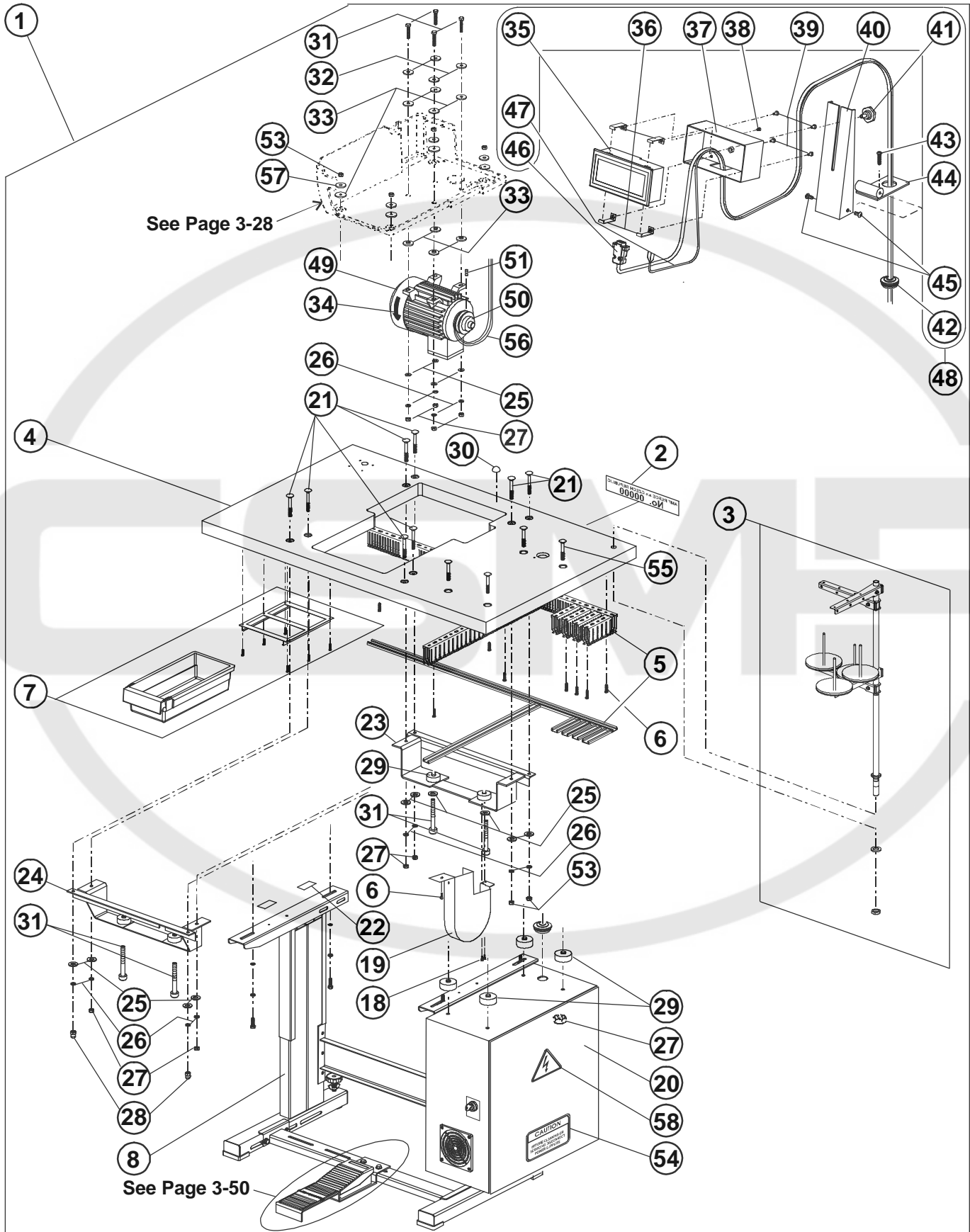

Revised 01/2007

E-mail: service@amfreece.cz; parts@amfreece.cz; website: www.amfreece.com
Phones: +420 582 309 146 (Service), +420 582 309 286 (Spare Parts); Fax: +420 582 360 606

TABLE

DET	PART NUMBER	DESCRIPTION	QTY.
01	03.5519.1.090	Table Assembly	1
02	04.1416.0.003	Label "No. xxxxx" ●●●	1
03	17.0003.6.156	Thread Stand Assembly	1
04	19.0091.0.402	Table Top ●●●	1
05	19.0095.2.403	Latch for Cable Kit ●●●	1
06	08.6632.3.016	Screw	15
07	12.0008.6.901	Drawer Kit ●●●	1
08	04.9000.2.123	Frame Kit	1
18	08.6000.4.008	Screw	2
19	19.0005.0.028	Cover Pulley ●●●	1
20	19.0006.9.448	Electrical Box Assembly ▫	1
21	08.6532.8.050	Screw	8
22	17.0094.0.200	Washer	4
23	19.0005.0.016	Framework	1
24	19.0005.0.015	Framework	1
25	08.6852.8.000	Washer	12
26	08.6802.8.000	Spring Washer	12
27	08.6702.8.000	Nut	14
28	08.6722.8.000	Nut	2
29	19.0095.1.405	Rubber Washer	8
30	12.0008.6.915	Holder	1
31	08.6312.8.040	Screw	8
32	01.4750.0.000	Washer	4
33	17.0095.1.272	Rubber Washer	12
34	17.0097.5.182	Label	1
35	19.8001.0.005	Display	(1)
36	19.0005.0.012	Panel Holder Got	(4)
37	19.0005.0.011	Display Box	(1)
38	08.6000.3.005	Screw	(1)
39	08.6032.4.010	Screw	(4)
40	19.0083.7.002	Display Box Holder	(1)
41	24.4019.0.000	Screw	(1)
42	12.0008.4.366	Bushing	(1)
43	08.6663.5.025	Screw	(1)
44	19.0005.0.013	Panel Stand Base	(1)
45	08.6200.6.010	Screw	(2)
46	12.0008.4.821	Cable	(1)
47	19.0007.9.477	Cable	(1)
48	03.5519.0.003	Touch Screen Assembly	1
49	12.0008.4.757	Motor	1
50	19.0052.0.501	Puley	1
51	08.6400.6.006	Screw M6x6	1
52			
53	08.6733.8.000	M8 Nut Lock	4
54	00.2751.3.602	Label	1
55	08.6532.8.070	Screw	4
56	12.5050.1.501	Belt	1
57	17.0019.0.441	Washer	4
58	17.0097.5.174	Label	1

Revised 01/2007

E-mail: service@amfreece.cz; parts@amfreece.cz; website: www.amfreece.com

Phones: +420 582 309 146 (Service), +420 582 309 286 (Spare Parts); Fax: +420 582 360 606

ELECTRONIC BOX -ELECTRONIC PARTS — I

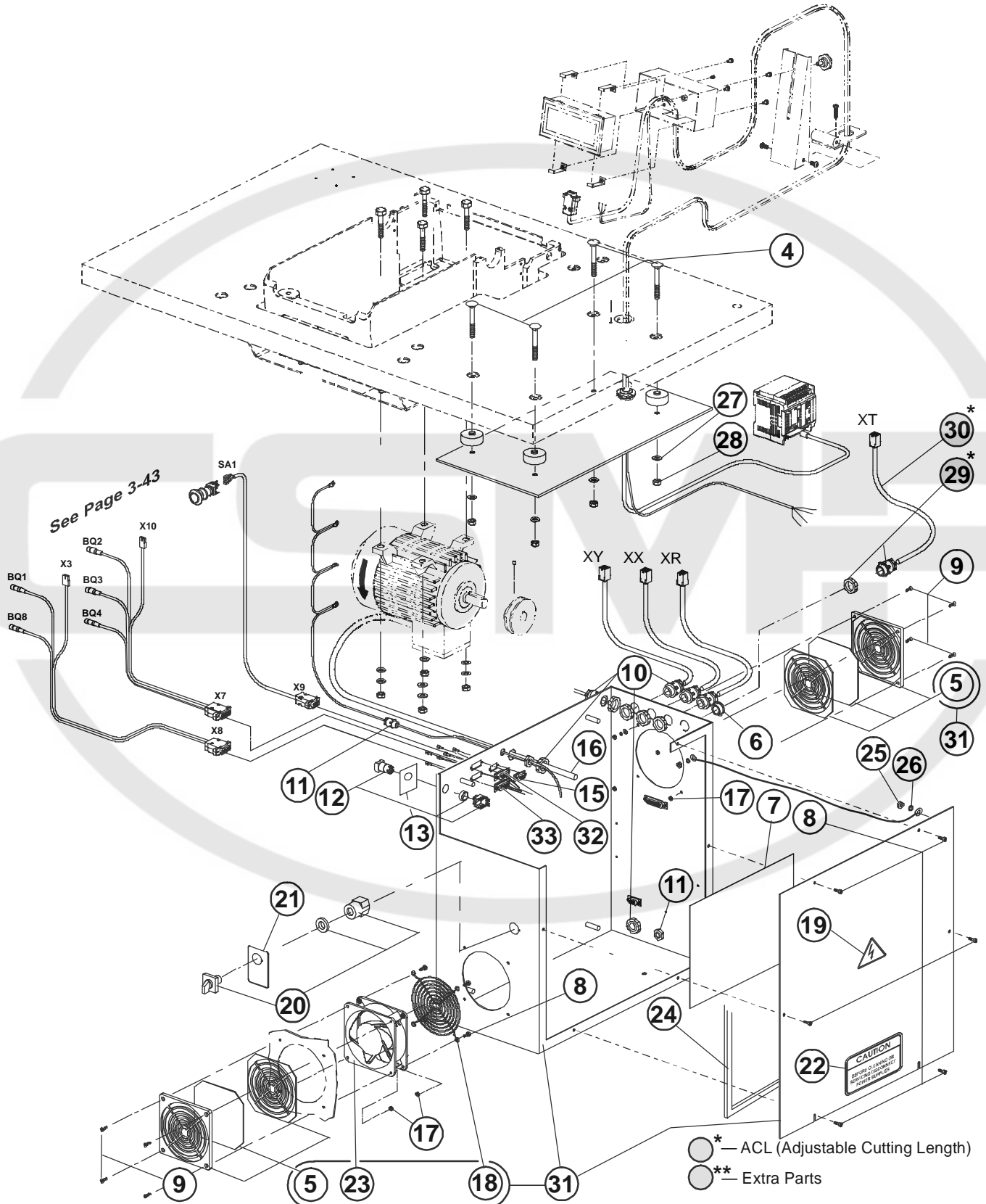

Revised 01/2007

E-mail: service@amfreece.cz; parts@amfreece.cz; website: www.amfreece.com

Phones: +420 582 309 146 (Service), +420 582 309 286 (Spare Parts); Fax: +420 582 360 606

ELECTRONIC BOX -ELECTRONIC PARTS — I

DET	PART NUMBER	DESCRIPTION	QTY.
04	08.6532.8.070	Screw	4
05	12.0008.4.761	Fan Cover With Filter ●●●	(2)
06	12.0008.4.777	Stopper ●●●	1
07	12.8000.0.077	Electrical Diagram Label	1
08	08.6032.4.012	Screw	14
09	08.6032.4.016	Screw	4
10	12.0008.4.231	Bushing ●●●	6
11	12.0008.4.207	Bushing ●●●	2
12	12.0008.4.613	Pushbutton (Green)	1
13	12.0008.4.615	Switch Unit (ZB6-E2B)	(1)
15	19.0007.9.023	Cable X9A	1
16	19.0007.9.008	Sew Motor	1
17	08.6702.4.000	Nut	12
18	12.0008.4.691	Fan Rack	(1)
19	12.0008.4.378	Label	1
20	12.0008.4.716	Knob	1
21	12.8000.0.423	Label	1
22	00.2751.3.602	Label "CAUTION"	1
23	12.0008.4.682	Fan	(1)
24	19.0094.2.410	Gasket	1
25	08.6702.6.000	Nut	2
26	08.6832.6.000	Washer	2
27	08.6852.8.000	Washer	4
28	08.6702.8.000	Nut	4
29*	12.0008.4.231	Bushing* ●●●	1*
30*	19.0007.9.011	Cable Motor * (T)	1*
31	19.0005.0.014	Driving Box	1
32	19.0007.9.021	Cable X7A	1
33	19.0007.9.022	Cable X8A	1

* — ACL (Adjustable Cutting Length)

Revised 01/2007

E-mail: service@amfreece.cz; parts@amfreece.cz; website: www.amfreece.com

Phones: +420 582 309 146 (Service), +420 582 309 286 (Spare Parts); Fax: +420 582 360 606

ELECTRONIC BOX -ELECTRONIC PARTS — II

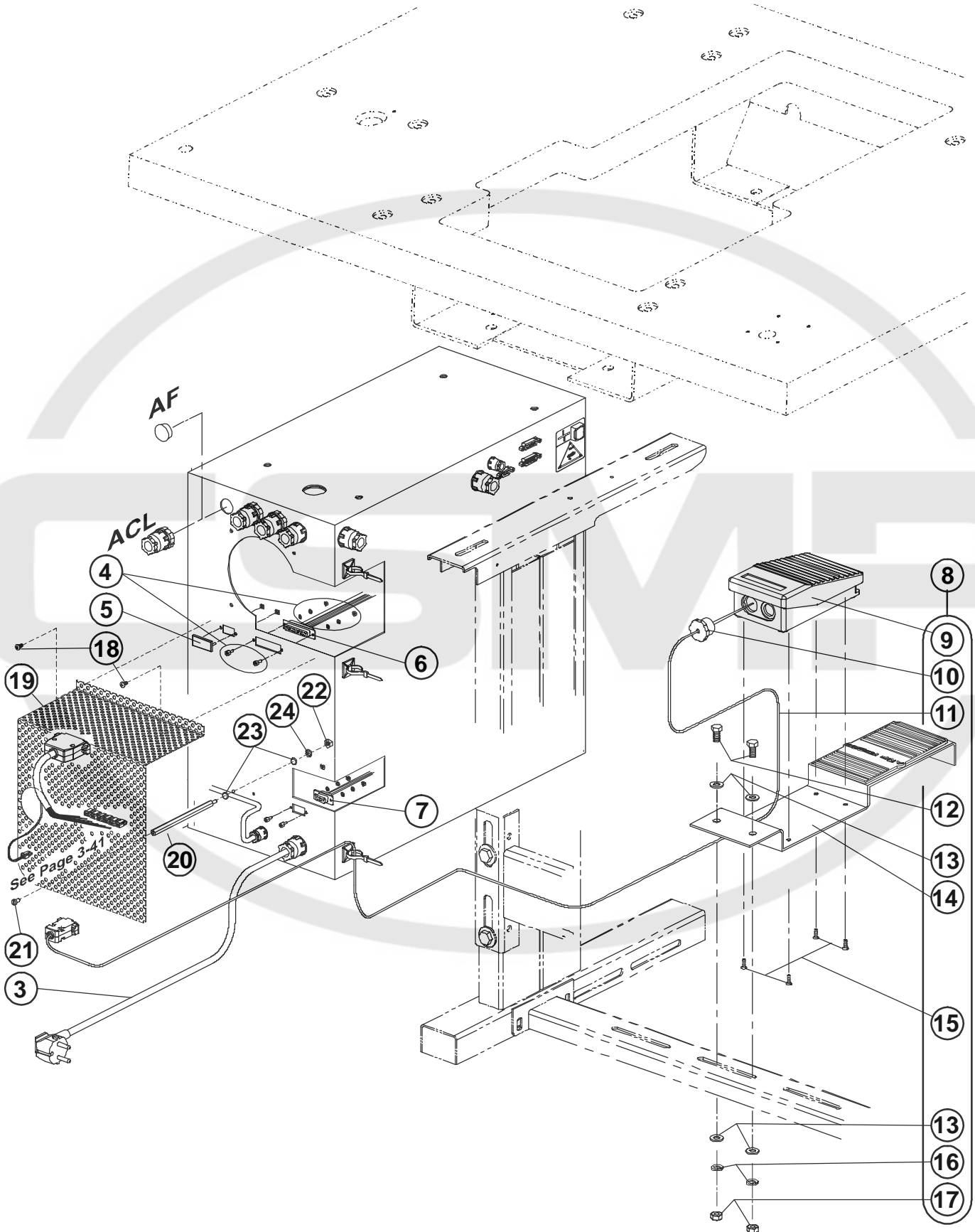

Revised 01/2007

E-mail: service@amfreece.cz; parts@amfreece.cz; website: www.amfreece.com
Phones: +420 582 309 146 (Service), +420 582 309 286 (Spare Parts); Fax: +420 582 360 606

ELECTRONIC BOX -ELECTRONIC PARTS — II

DET	PART NUMBER	DESCRIPTION	QTY.
03	12.0008.4.885	Cable Flexo	1
04	12.0008.4.710	Screw Kit	5
05	12.0008.4.758	Stopper	1
06	19.0007.9.018	Cable X4A	1
07	19.0007.9.019	Cable X5A	1
08	19.0007.9.037	Pedal Assembly	1
09	12.0008.4.204	Pedal ●●●	(1)
10	12.0008.4.296	Bushing ●●●	(1)
11	19.0007.9.036	Cable	(1)
12	08.6312.8.020	Screw	(2)
13	08.6852.8.000	Washer	(4)
14	24.0097.0.000	Holder Pedal	(1)
15	08.6100.4.012	Screw	(4)
16	08.6802.8.000	Spring Washer	(2)
17	08.6702.8.020	Screw	(2)
18	08.6662.4.010	Screw	2
19	19.0083.1.687	Cover	1
20	19.0014.6.408	Distance Nut	1
21	08.6010.4.008	Screw	2
22	08.6702.4.000	Nut	1
23	08.6852.4.000	Washer	2
24	08.6832.4.000	Washer Serated	1

Revised 01/2007

E-mail: service@amfreece.cz; parts@amfreece.cz; website: www.amfreece.com

Phones: +420 582 309 146 (Service), +420 582 309 286 (Spare Parts); Fax: +420 582 360 606

ELECTRONIC BOX -ELECTRONIC PARTS — III

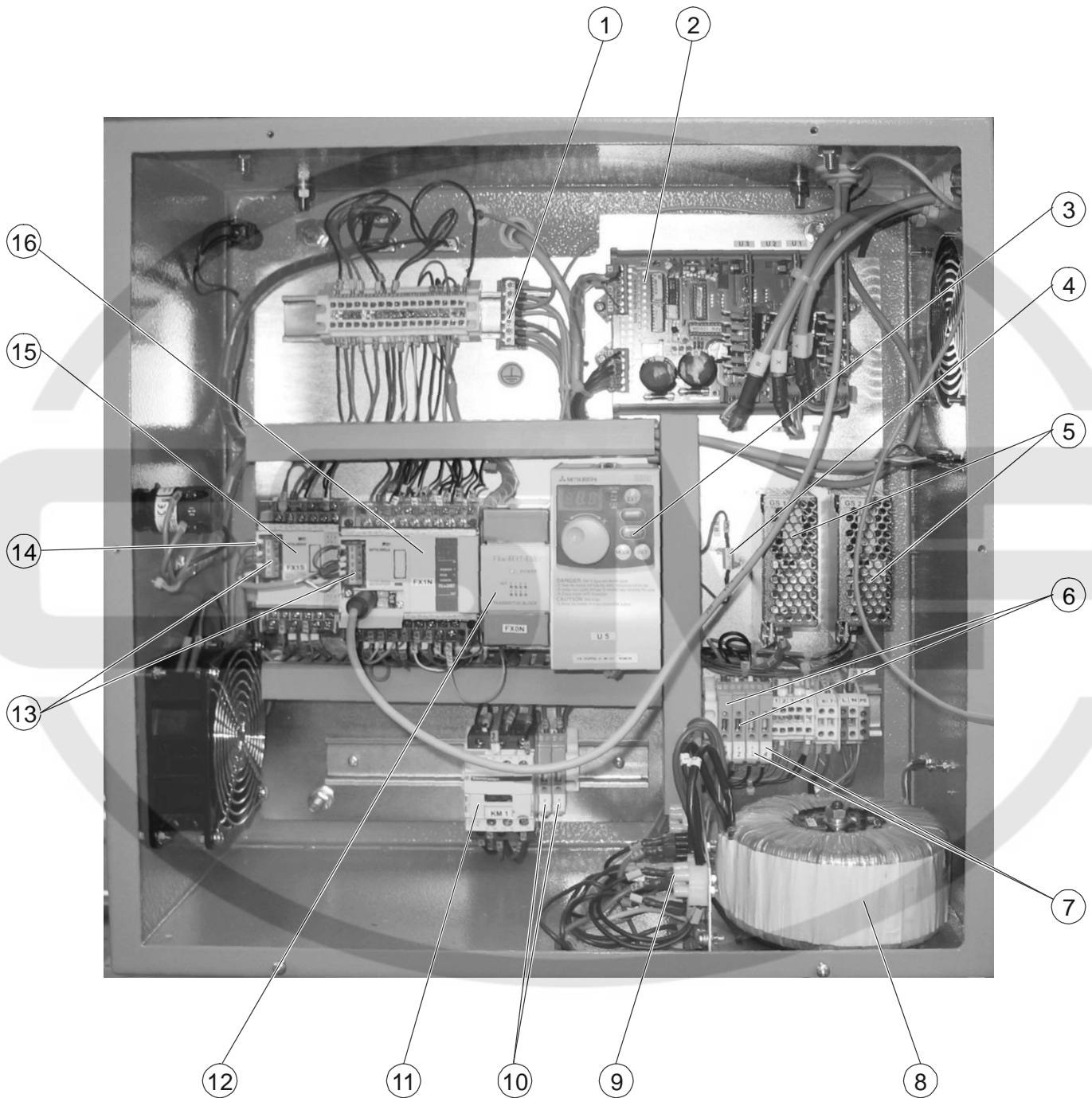

Revised 01/2007

E-mail: service@amfreece.cz; parts@amfreece.cz; website: www.amfreece.com
Phones: +420 582 309 146 (Service), +420 582 309 286 (Spare Parts); Fax: +420 582 360 606

VERSION AF

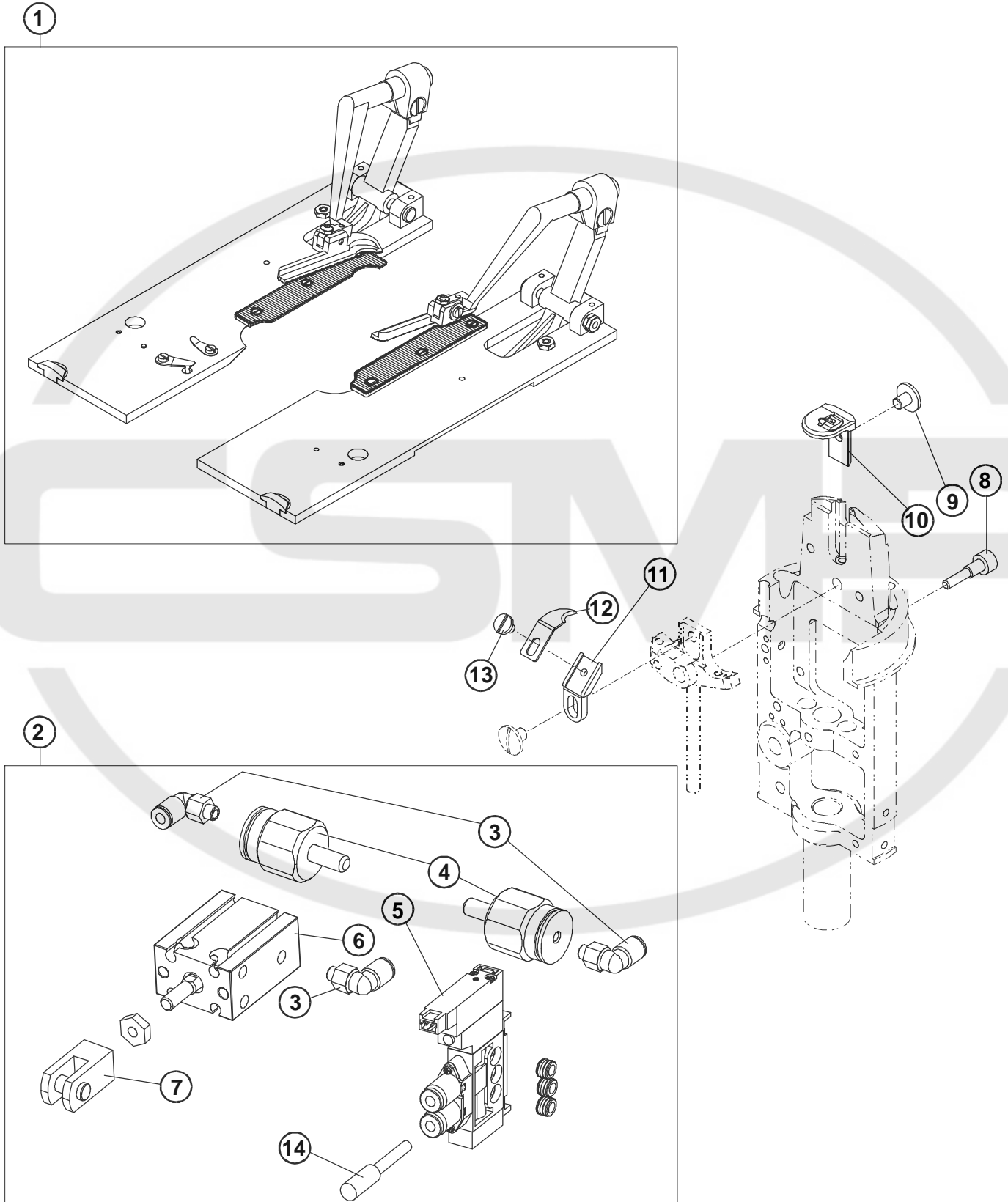

Revised 01/2007

E-mail: service@amfreece.cz; parts@amfreece.cz; website: www.amfreece.com

Phones: +420 582 309 146 (Service), +420 582 309 286 (Spare Parts); Fax: +420 582 360 606

VERSION CT

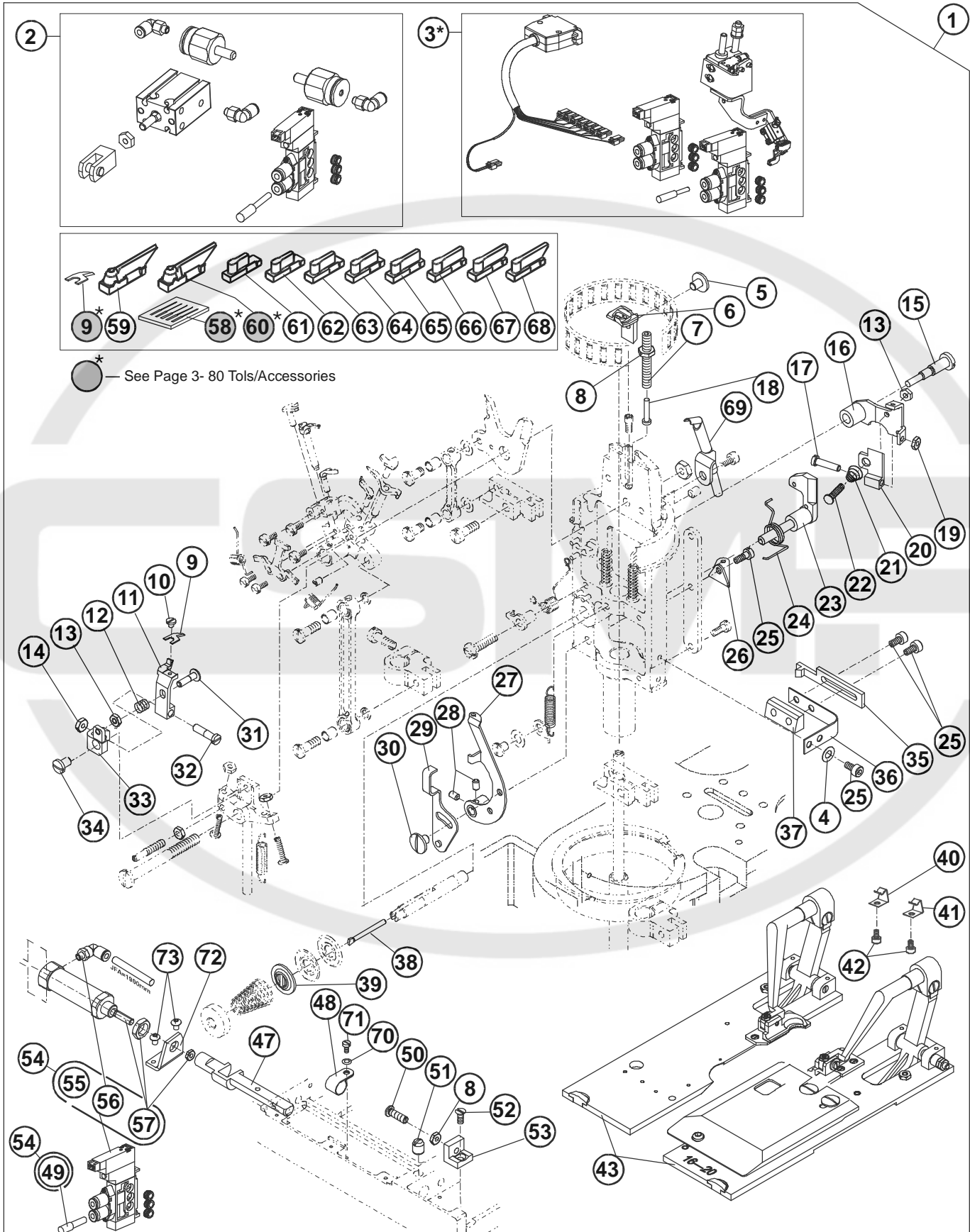

Revised 01/2007

E-mail: service@amfreece.cz; parts@amfreece.cz; website: www.amfreece.com

Phones: +420 582 309 146 (Service), +420 582 309 286 (Spare Parts); Fax: +420 582 360 606

VERSION CT

DET	PART NUMBER	DESCRIPTION	QTY.
01	03.5519.3.016	Kit S311 CT 16 — 20	1
	03.5519.3.020	Kit S311 CT 20 — 24	
	03.5519.3.024	Kit S311 CT 24 — 28	
	03.5519.3.028	Kit S311 CT 28 — 32	
	03.5519.3.029	Kit S311 CT 16 — 32	
02	See Page 3-53	Kit Pneumatics AF	(1)
03*	See Page 3-63	Kit Thread Clamp S311 (03.5519.3.013)	(1)
04	08.6850.3.000	Washer	(1)
05	01.2056.1.000	Screw	(1)
06	10.4012.2.014	Throat Plate C36-21	(1)
07	19.0011.2.402	Screw	(1)
08	08.6710.5.000	Nut	(2)
09	19.0087.0.420	Knife CT*	(1+1*)
10	17.0012.0.688	Screw *	(1)
11	19.0061.6.401	Knife Holder CT*	(1)
12	17.0026.0.218	Spring	(1)
13	08.6700.3.000	Nut	(2)
14	17.0016.1.401	Nut	(1)
15	19.0013.1.491	Screw	(1)
16	19.0005.2.209	Abductor Bracket	(1)
17	19.0013.1.492	Screw	(1)
18	19.0032.2.405	Stud	(1)
19	19.0016.1.403	Nut	(1)
20	17.0082.6.402	Thread Holder	(1)
21	17.0026.2.054	Spring	(1)
22	17.0013.6.081	Screw	(2)
23	19.0005.2.210	Lever	(1)
24	18.0026.4.403	Spring	(1)
25	08.6010.3.006	Screw	(4)
26	19.0082.3.416	Support	(1)
27	19.0005.2.216	Lever	(1)
28	08.6400.4.004	Screw	(2)
29	19.0082.2.526	Lever	(1)
30	17.0012.1.137	Screw	(1)
31	17.0014.1.178	Screw	(1)
32	17.0013.1.482	Screw	(1)
33	19.0082.6.420	Holder	(1)
34	19.0012.0.689	Screw	(1)
35	19.0062.5.405	Lever	(1)
36	18.0028.3.401	Spring	(1)
37	18.0082.6.406	Block	(1)
38	18.0031.0.481	Pin	(1)
39	17.0082.8.082	Release Washer	(1)
40	19.0028.3.403	Spring Clip L.H.	(1)
41	19.0028.3.404	Spring Clip R.H.	(1)
42	19.0012.5.400	Screw M3-2,3	(2)
43	See Table Below	Clamps	(1)
44			
45			

* — Tools/Accessories



VERSION CT

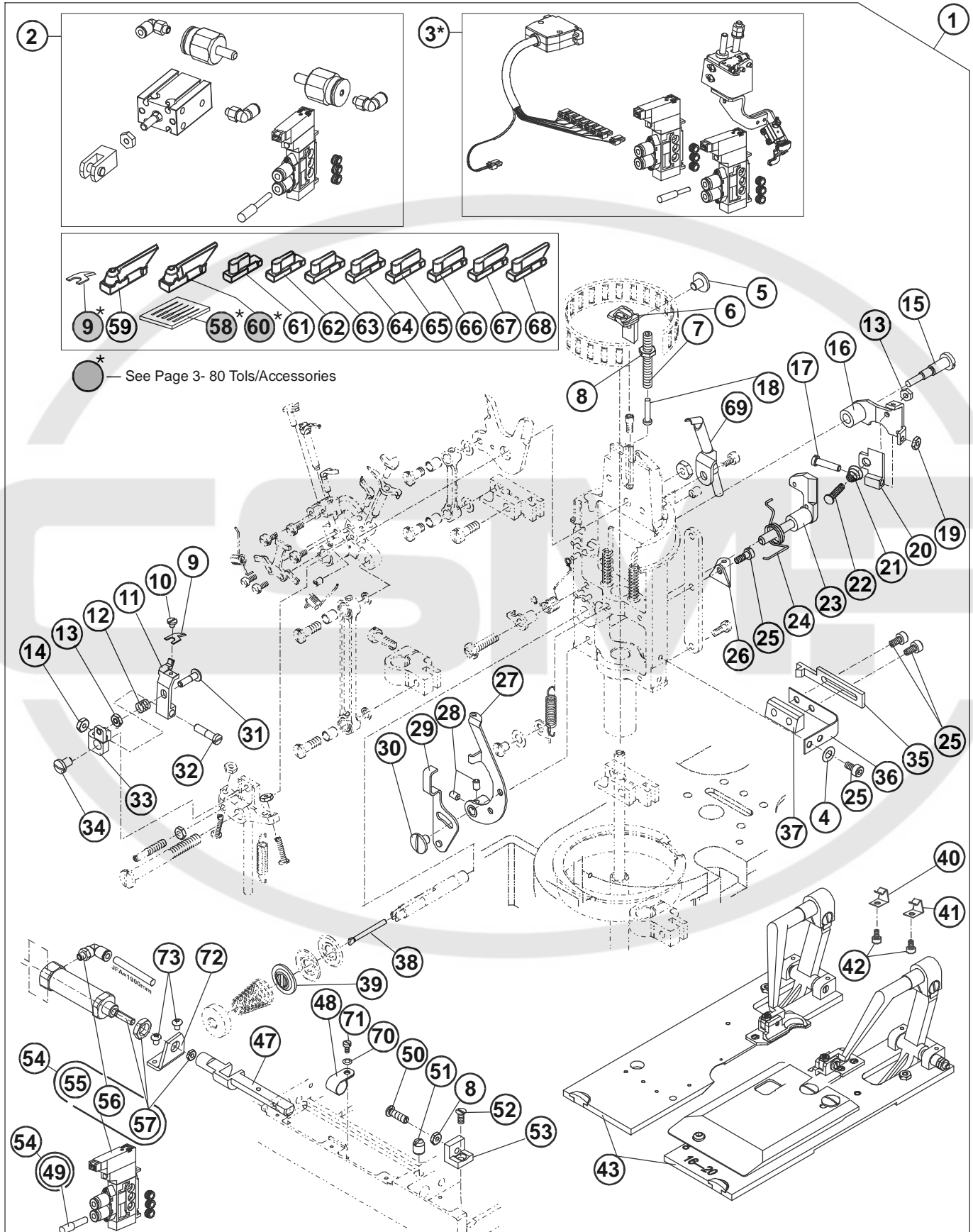

Revised 01/2007

E-mail: service@amfreece.cz; parts@amfreece.cz; website: www.amfreece.com

Phones: +420 582 309 146 (Service), +420 582 309 286 (Spare Parts); Fax: +420 582 360 606

VERSION CT



DET	PART NUMBER	DESCRIPTION	QTY.
46			
47	19.0036.2.405	Rod	(1)
48	12.0008.4.280	Cord Clamp	(1)
49	12.0008.3.426	Plug	(1)
50	17.0012.7.007	Screw	(1)
51	19.0011.1.400	Screw	(1)
52	08.6100.4.010	Screw	(1)
53	19.0064.6.472	Stop	(1)
54	12.0008.3.532	Kit Pneumatics S311 CT	(1)
55	12.0008.3.482	Pneumatic Valve	((1))
56	12.0008.3.411	Connector	((1))
57	12.0008.3.649	Cylinder	((1))
58*	02.0558.1.112	Needle 558 Nm110	6
59	19.0087.0.432	Knife 28x42-38	1
60*	19.0087.0.434	Knife 32x50-38	1
61	See Table Below	Cuting Steel 16T	—
62	See Table Below	Cuting Steel 18T	—
63	See Table Below	Cuting Steel 20T	—
64	See Table Below	Cuting Steel 22T	—
65	See Table Below	Cuting Steel 24T	—
66	See Table Below	Cuting Steel 26T	—
67	See Table Below	Cuting Steel 29T	—
68	See Table Below	Cuting Steel 32T	—
69	19.0002.5.409	Cable Long	1
70	08.6852.4.000	Washer	1
71	08.6000.3.008	Screw	1
72	19.0082.3.463	Washer	1
73	08.6200.4.006	Screw	2

* — Tools/Accessories

DET	Kit Version CT										DESCRIPTION
	03.5519.3.016		03.5519.3.020		03.5519.3.024		03.5519.3.028		03.5519.3.029		
	S311 CT 16 — 20		S311 CT 20 — 24		S311 CT 24 — 28		S311 CT 28 — 32		S311 CT 16 — 32		
	PART NUMBER	QTY.	PART NUMBER	QTY.	PART NUMBER	QTY.	PART NUMBER	QTY.	PART NUMBER	QTY.	
43	19.0003.1.661	1	—	—	—	—	—	—	19.0003.1.661	1	Clamps S311 CT 16—20
	—	—	19.0003.1.662	1	—	—	—	—	19.0003.1.662	1	Clamps S311 CT 20—24
	—	—	—	—	19.0003.1.663	1	—	—	19.0003.1.663	1	Clamps S311 CT 24—28
	—	—	—	—	—	—	19.0003.1.664	1	19.0003.1.664	1	Clamps S311 CT 16—32
61	19.0064.5.849	1	—	—	—	—	—	—	19.0064.5.849	1	Cuting Steel 16T
62	19.0064.5.850	1	—	—	—	—	—	—	19.0064.5.850	1	Cuting Steel 18T
63	19.0064.5.851	1	19.0064.5.851	1	—	—	—	—	19.0064.5.851	1	Cuting Steel 20T
64	—	—	19.0064.5.852	1	—	—	—	—	—	—	Cuting Steel 22T
65	—	—	19.0064.5.853	1	19.0064.5.853	1	—	—	—	—	Cuting Steel 24T
66	—	—	—	—	19.0064.5.854	1	—	—	—	—	Cuting Steel 26T
67	—	—	—	—	19.0064.5.855	1	19.0064.5.855	1	—	—	Cuting Steel 29T
68	—	—	—	—	—	—	19.0064.5.856	1	19.0064.5.856	1	Cuting Steel 32T

Revised 01/2007

E-mail: service@amfreece.cz; parts@amfreece.cz; website: www.amfreece.com

Phones: +420 582 309 146 (Service), +420 582 309 286 (Spare Parts); Fax: +420 582 360 606

VERSION CT CLAMPING

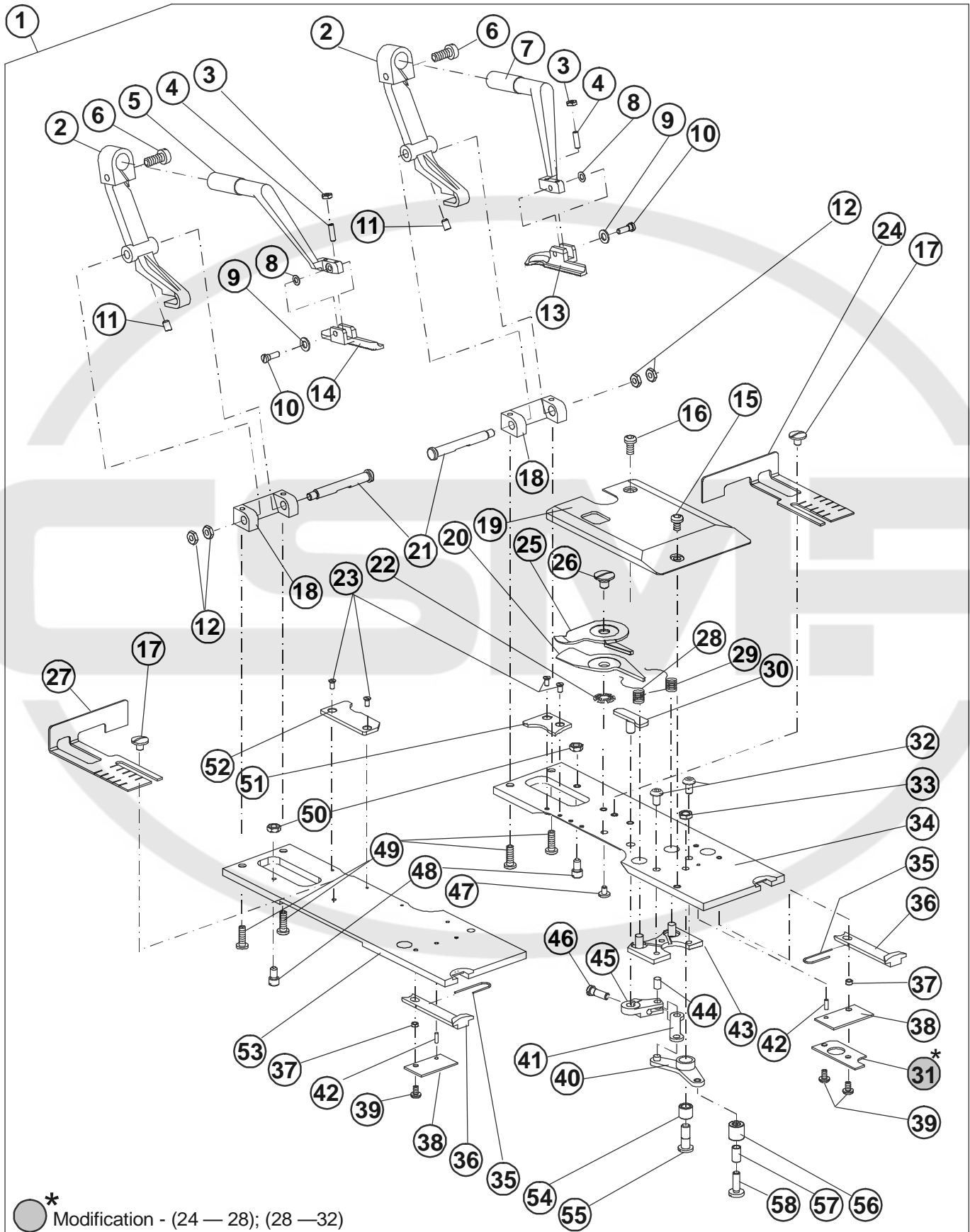

Revised 01/2007

E-mail: service@amfreece.cz; parts@amfreece.cz; website: www.amfreece.com

Phones: +420 582 309 146 (Service), +420 582 309 286 (Spare Parts); Fax: +420 582 360 606

VERSION CT CLAMPING

DET	PART NUMBER	DESCRIPTION	QTY.
01	19.0003.1.661	Modification (16—20)	
	19.0003.1.662	Modification (20—24)	
	19.0003.1.663	Modification (24—28)	
	19.0003.1.664	Modification (28—32)	
02	19.0063.5.406	Clamp Arm Base	2
03	08.6710.3.000	Nut	2
04	08.6400.3.010	Screw	2
05	19.0066.8.401	L.H. Clamp Arm	1
06	08.6010.5.012	Screw	2
07	19.0066.8.400	R.H. Clamp Arm	1
08	17.0019.2.066	Curved Spring Washer	2
09	17.0019.5.040	Lockwasher	2
10	17.0013.5.067	Screw	2
11	08.6400.4.006	Screw	2
12	08.6710.4.000	Nut	4
13	See Table Below	R.H. Clamp Foot	—
14	See Table Below	L.H. Clamp Foot	—
15	08.6200.4.006	Screw	1
16	08.6200.4.008	Screw	1
17	17.0012.4.106	Screw	2
18	19.0064.7.402	Block	2
19	19.0074.6.215	Cover Plate	1
20	19.0087.0.428	Lower Shear	1
21	19.0032.8.401	Screw	2
22	12.3013.0.002	Washer	1
23	17.0012.3.054	Screw	4
24			
25	19.0087.0.425	Upper Shear	1
26	19.0013.1.498	Pivot Screw	1
27	19.0082.6.421	L.H. Cloth Gauge	1
28	17.0026.4.065	L.H. Spring	1
29	17.0026.4.064	R.H. Spring	1
30	19.0062.5.404	Actuator	1
31	See Table Below	Cover	—
32	17.0012.4.103	Screw	2
33	17.0016.1.054	Nut	1
34	See Table Below	R.H. Plate	—
35	19.0027.1.610	Spring	2
36	19.0062.5.408	Pawl	2
37	19.0041.0.684	Ring	2
38	See Table Below	Cover	—
39	See Table Below	Screw	—
40	See Table Below	Lever	—
41	See Table Below	Lever	—
42	See Table Below	Pin	—
43	19.0005.2.212	Actuator	1
44	12.1010.0.408	Pin	1
45	19.0061.3.605	Lower Lever	1
46	17.0012.0.543	Screw	1
47	17.0012.0.605	Screw	1



Revised 01/2007

E-mail: service@amfreece.cz; parts@amfreece.cz; website: www.amfreece.com

Phones: +420 582 309 146 (Service), +420 582 309 286 (Spare Parts); Fax: +420 582 360 606

VERSION CT CLAMPING

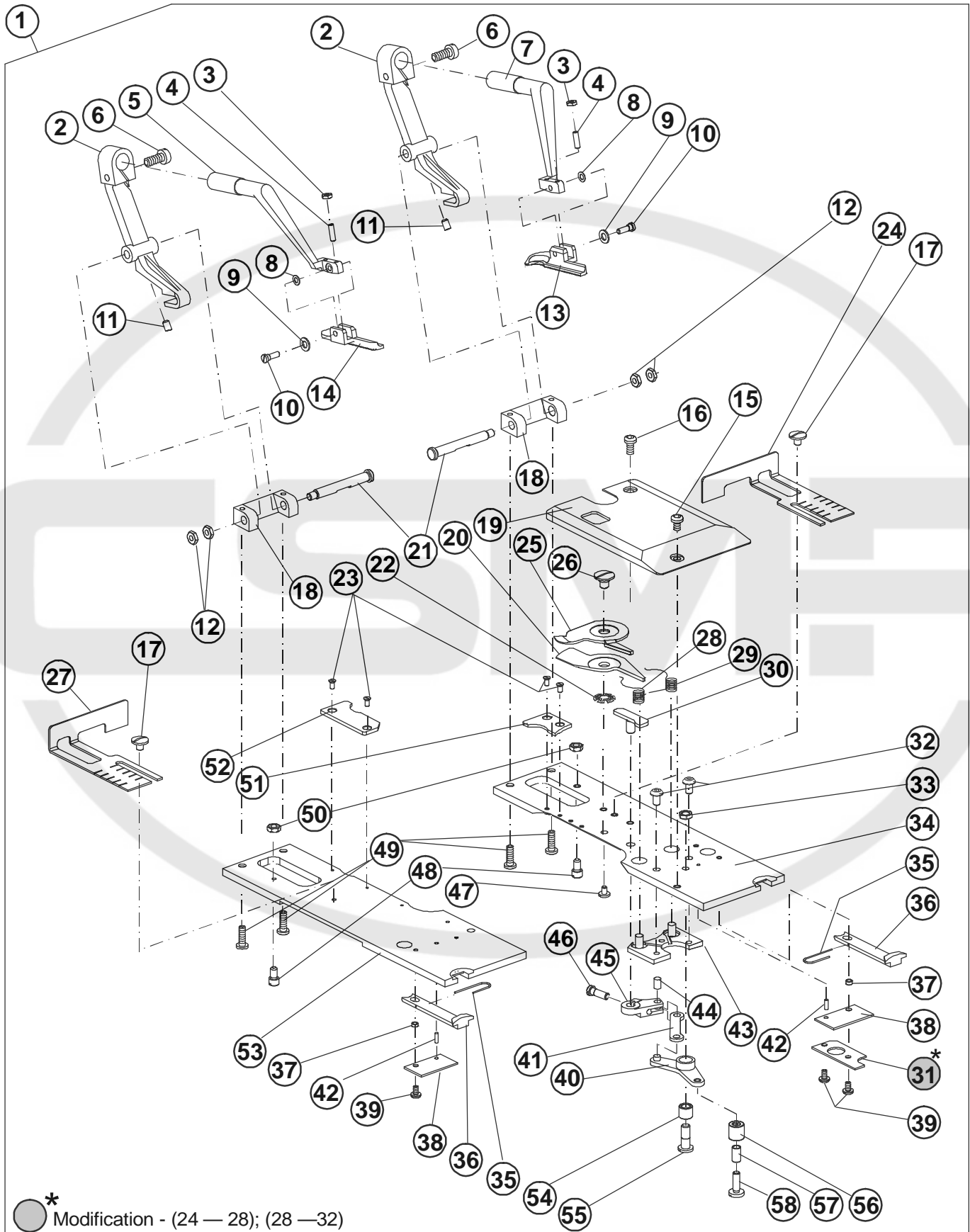

Revised 01/2007

E-mail: service@amfreece.cz; parts@amfreece.cz; website: www.amfreece.com

Phones: +420 582 309 146 (Service), +420 582 309 286 (Spare Parts); Fax: +420 582 360 606

VERSION CT CLAMPING



DET	PART NUMBER	DESCRIPTION	QTY.
48	19.0033.1.401	Screw	2
49	08.6010.4.012	Screw	4
50	19.0016.1.402	Nut	2
51	See Table Below	R.H. Clamp Mat	—
52	See Table Below	L.H. Clamp Mat	—
53	19.0081.5.433	L.H. Plate	1
54	19.0044.1.626	Roll	1
55	19.0012.1.404	Screw	1
56	12.2050.1.005	Needle Bearing	1
57	19.0041.1.400	Roll	1
58	17.0012.1.142	Screw	1

* — Extra Part for CT



DET	MODIFICATION KIT — BUTTONHOLE LENGTH								DESCRIPTION
	19.0003.1.661		19.0003.1.662		19.0003.1.663		19.0003.1.664		
	16—20		20—24		24—28		28—32		
	PART NUMBER	QTY.	PART NUMBER	QTY.	PART NUMBER	QTY.	PART NUMBER	QTY.	
13	19.0066.7.424	1	19.0066.7.412	1	19.0066.7.428	1	19.0066.7.426	1	R.H. Clamp Foot
14	19.0066.7.425	1	19.0066.7.413	1	19.0066.7.429	1	19.0066.7.427	1	L.H. Clamp Foot
34	19.0081.5.462	1	19.0081.5.464	1	19.0081.5.466	1	19.0081.5.468	1	R.H. Plate
31	—		—		19.0081.5.441		1		Cover
38	19.0081.5.449		2		19.0081.5.449		1		Cover
39	08.6200.3.005		2		08.6200.3.005		2+1*		Screw
40	19.0063.3.402				1	19.0063.3.405		1	Lever
41	19.0081.0.512	1	19.0081.0.513				1		Lever
42	12.1010.0.206			2	12.1010.0.206			1	Pin
51	19.0081.1.766	1	18.0081.1.404	1	19.0081.1.768	1	19.0081.1.764	1	R.H. Clamp Mat
52	19.0081.1.767	1	18.0081.1.403	1	19.0081.1.769	1	19.0081.1.765	1	L.H. Clamp Mat

Revised 01/2007

E-mail: service@amfreece.cz; parts@amfreece.cz; website: www.amfreece.com

Phones: +420 582 309 146 (Service), +420 582 309 286 (Spare Parts); Fax: +420 582 360 606

VERSION CT/LTT — THREAD CLAMP

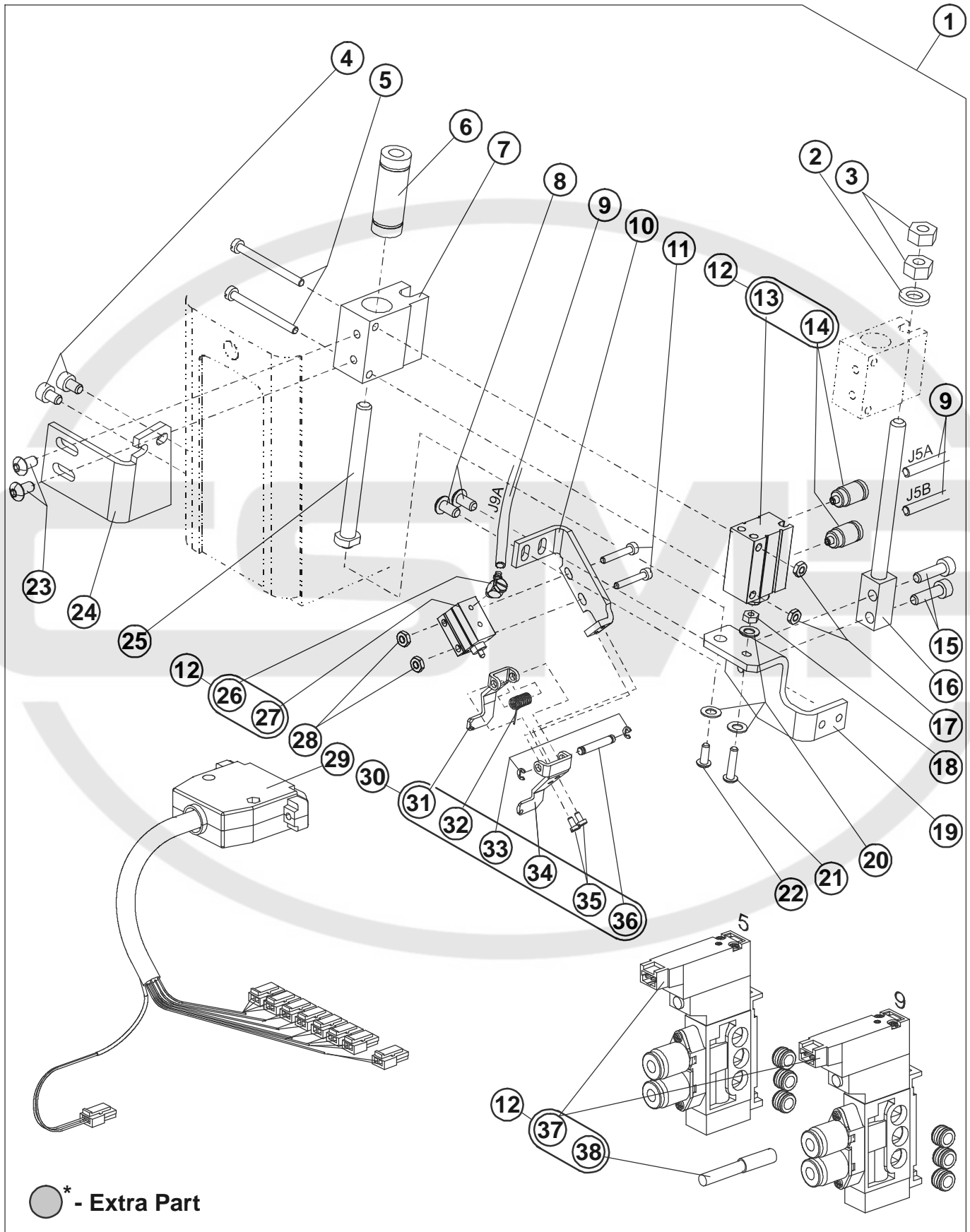

Revised 01/2007

E-mail: service@amfreece.cz; parts@amfreece.cz; website: www.amfreece.com

Phones: +420 582 309 146 (Service), +420 582 309 286 (Spare Parts); Fax: +420 582 360 606

VERSION LTT

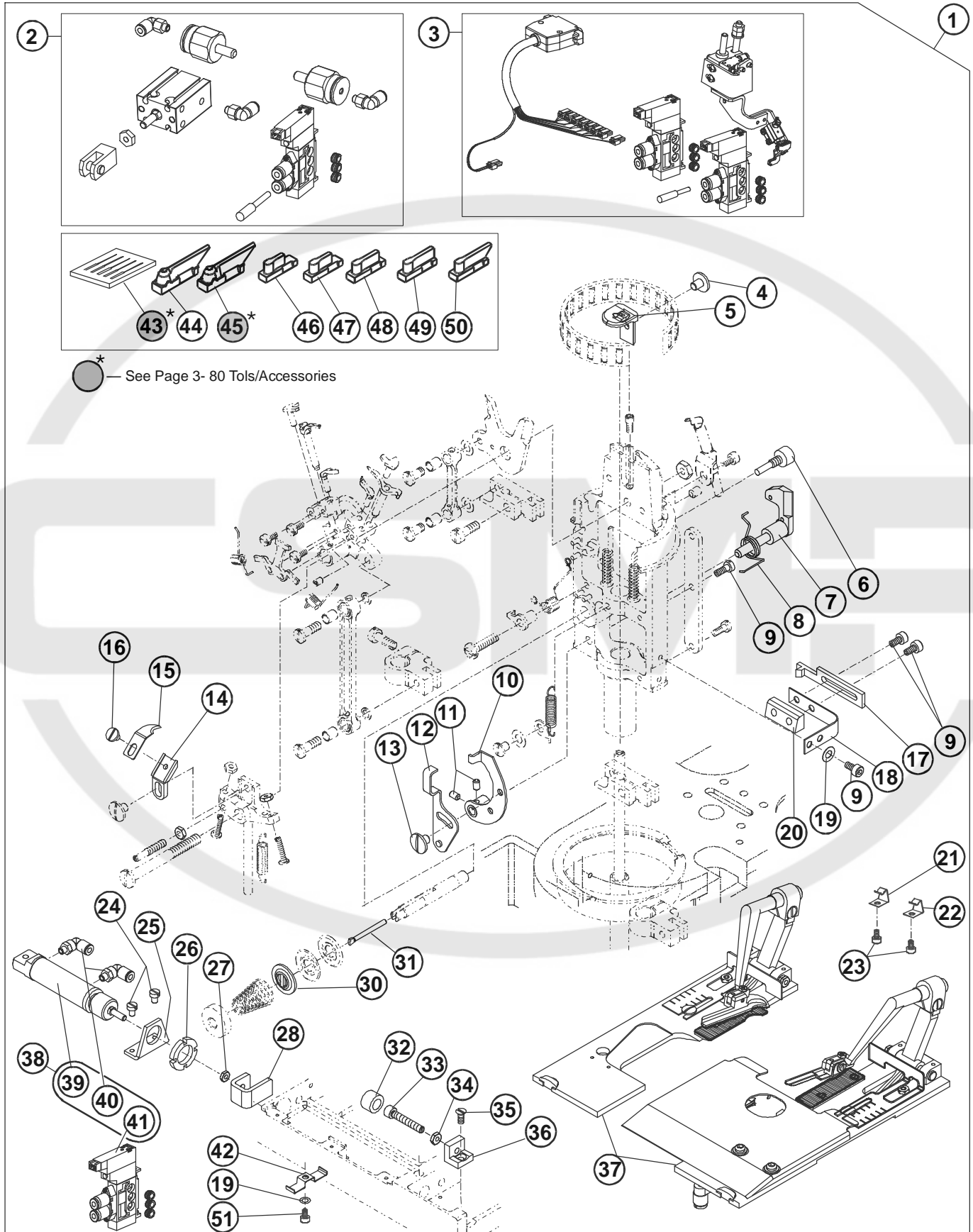

Revised 01/2007

E-mail: service@amfreece.cz; parts@amfreece.cz; website: www.amfreece.com

Phones: +420 582 309 146 (Service), +420 582 309 286 (Spare Parts); Fax: +420 582 360 606

VERSION LTT

DET	PART NUMBER	DESCRIPTION	QTY.
01	03.5519.3.030	Kit S311 LTT	1
02	12.0008.3.531	Kit Pneu S311 AF	(1)
03	03.5519.3.013	Kit Thread Clamp	(1)
04	01.2056.1.000	Screw	(1)
05	10.4012.0.032	Throat Plate LTT	(1)
06	19.0013.0.001	Screw	(1)
07	19.0005.2.210	Lever	(1)
08	18.0026.4.403	Spring	(1)
09	08.6010.3.006	Screw	(3)
10	19.0005.2.219	Lever	(1)
11	08.6400.4.004	Screw	(2)
12	19.0082.2.526	Lever	(1)
13	17.0012.1.137	Screw	(1)
14	19.0082.3.410	Knife Holder	(1)
15	17.0087.0.204	Knife	(1)
16	17.0012.0.688	Screw	(1)
17	19.0062.5.405	Lever	(1)
18	18.0028.3.401	Spring	(1)
19	08.6850.3.000	Washer	(2)
20	18.0082.6.406	Block	(1)
21	19.0028.3.403	Spring Clip L.H.	(1)
22	19.0028.3.404	Spring Clip R.H.	(1)
23	19.0012.5.400	Screw M3-2,3	(2)
24	08.6012.4.006	Screw M4x6	(2)
25	19.0082.3.435	Holder	(1)
26	19.0016.3.408	Nut	(1)
27	08.6702.6.000	Nut M6	(1)
28	19.0082.3.434	Actuator	(1)
30	17.0082.8.082	Release Washer	(1)
31	18.0031.0.481	Pin	(1)
32	19.0095.1.406	Rest	(1)
33	08.6000.5.060	Screw M5x60	(1)
34	08.6710.5.000	Nut	(1)
35	08.6100.4.010	Screw	(1)
36	19.0064.6.472	Stop	(1)
37	19.0003.1.655	Kit Clamps	(1)
38	12.0008.3.534	Kit Pneumatics S311 LTT	(1)
39	12.0008.3.622	Cylinder	((1))
40	12.0008.3.411	Connector	((2))
41	12.0008.3.482	Pneumatic Valve	((1))
42	19.0082.6.434	Holder Tube	(2)
43	02.0558.0.111	Needle 558 Nm100	(5)
44	19.0087.0.432	Knife 28x42-38	(1)
45	19.0087.0.434	Knife 32x50-38	(1)
46	19.0064.5.849	Cuting Steel 16T	(1)
47	19.0064.5.952	Cuting Steel 19T	(1)
48	19.0064.5.852	Cuting Steel 22T	(1)
49	19.0064.5.854	Cuting Steel 26T	(1)
50	19.0064.5.856	Cuting Steel 32T	(1)
51	08.6000.3.006	Screw	1

Revised 01/2007

E-mail: service@amfreece.cz; parts@amfreece.cz; website: www.amfreece.com

Phones: +420 582 309 146 (Service), +420 582 309 286 (Spare Parts); Fax: +420 582 360 606

VERSION LTT — CLAMPING

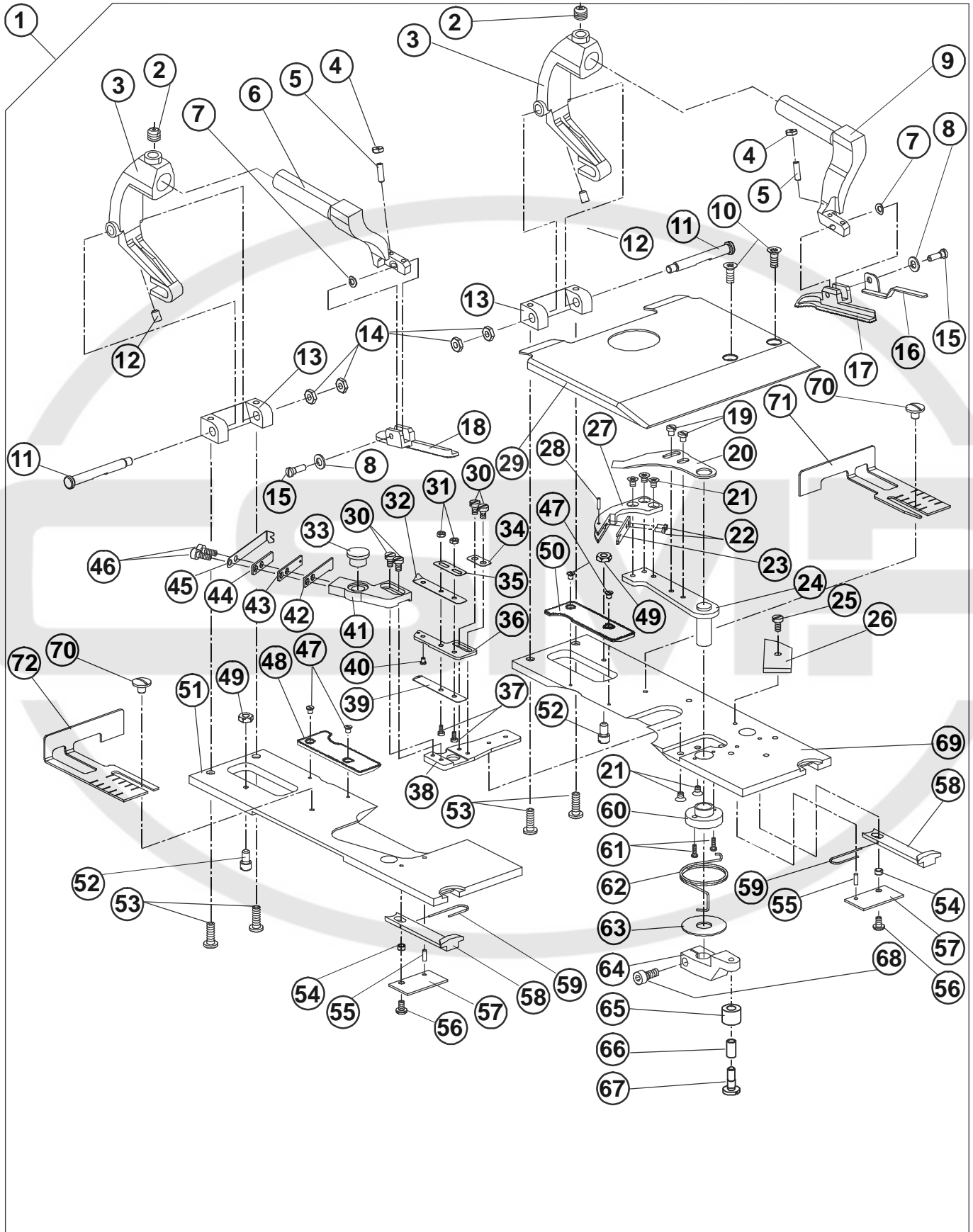

Revised 01/2007

E-mail: service@amfreece.cz; parts@amfreece.cz; website: www.amfreece.com

Phones: +420 582 309 146 (Service), +420 582 309 286 (Spare Parts); Fax: +420 582 360 606

VERSION LTT — CLAMPING

DET	PART NUMBER	DESCRIPTION	QTY.
01	19.0003.1.665	Kit — LTT	1
02	08.6400.6.006	Screw	(2)
03	19.0063.5.418	Clamp Arm Base	(2)
04	08.6710.3.000	Nut	(2)
05	08.6400.3.010	Screw	(2)
06	19.0066.8.405	L.H.Clamp Arm	(1)
07	17.0019.2.066	Curved Spring Washer	(2)
08	17.0019.5.040	Lockwasher	(2)
09	19.0066.8.406	R.H.Clamp Arm	(1)
10	08.6132.4.010	Screw	(2)
11	19.0032.8.401	Shaft	(2)
12	08.6400.4.006	Screw	(2)
13	19.0064.7.402	Block	(2)
14	08.6710.4.000	Nut	(4)
15	17.0013.5.067	Screw	(2)
16	19.0082.3.439	Holder Cloth	(1)
17	19.0066.7.422	R.H.Clamp Foot	(1)
18	19.0066.7.423	L.H.Clamp Foot	(1)
19	17.0012.0.077	Screw	(2)
20	19.0082.6.427	Lower Thread Grasping Opener	(1)
21	08.6117.3.004	Screw	(5)
22	08.6010.2.004	Screw	(2)
23	19.0082.1.405	Treating Plate	(1)
24	19.0005.2.215	Lever	(1)
25	08.6012.3.006	Screw	(1)
26	19.0094.0.410	Rubber	(1)
27	19.0087.0.424	Knife	(1)
28	12.1014.0.000	Spring Pin	(1)
29	19.0004.1.402	Cover	(1)
30	08.6117.3.005	Screw	(4)
31	08.6702.2.000	Nut	(2)
32	19.0081.5.452	Gimp Grasping	(1)
33	19.0094.1.401	Rubber	(1)
34	19.0081.5.451	Grasping Spacer	(1)
35	19.0028.3.407	Spring	(1)
36	19.0082.6.432	Grasping Fixing Plate	(1)
37	08.6012.2.006	Screw	(2)
38	19.0082.6.426	Support Plate	(1)
39	19.0082.3.438	Lower Thread Grasping	(1)
40	19.0031.3.404	Pin	(1)
41	19.0066.8.402	Knife Holder	(1)
42	19.0081.5.453	Fixing Knife	(1)
43	19.0028.3.405	Spring Lower	(1)
44	19.0028.3.406	Spring Upper	(1)
45	19.0082.3.437	Guide Plate	(1)
46	08.6000.3.008	Screw	(2)
47	17.0012.3.054	Screw	(4)
48	19.0081.1.771	L.H. Long Clamp	(1)
49	19.0016.1.402	Nut	(2)
50	19.0081.1.770	R.H. Long Clamp	(1)



Revised 01/2007

E-mail: service@amfreece.cz; parts@amfreece.cz; website: www.amfreece.com

Phones: +420 582 309 146 (Service), +420 582 309 286 (Spare Parts); Fax: +420 582 360 606

VERSION LTT — CLAMPING

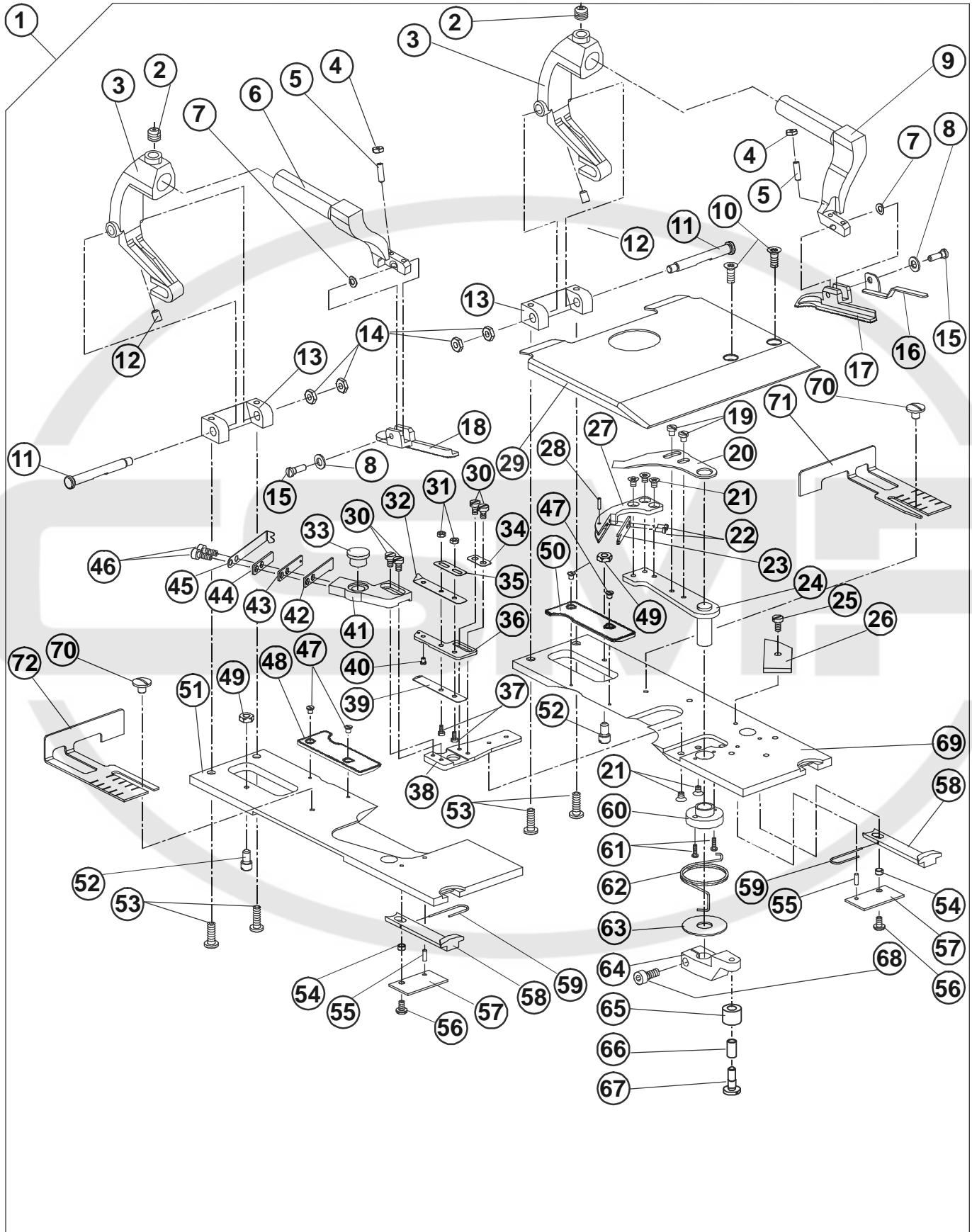

Revised 01/2007

E-mail: service@amfreece.cz; parts@amfreece.cz; website: www.amfreece.com

Phones: +420 582 309 146 (Service), +420 582 309 286 (Spare Parts); Fax: +420 582 360 606

VERSION ACL

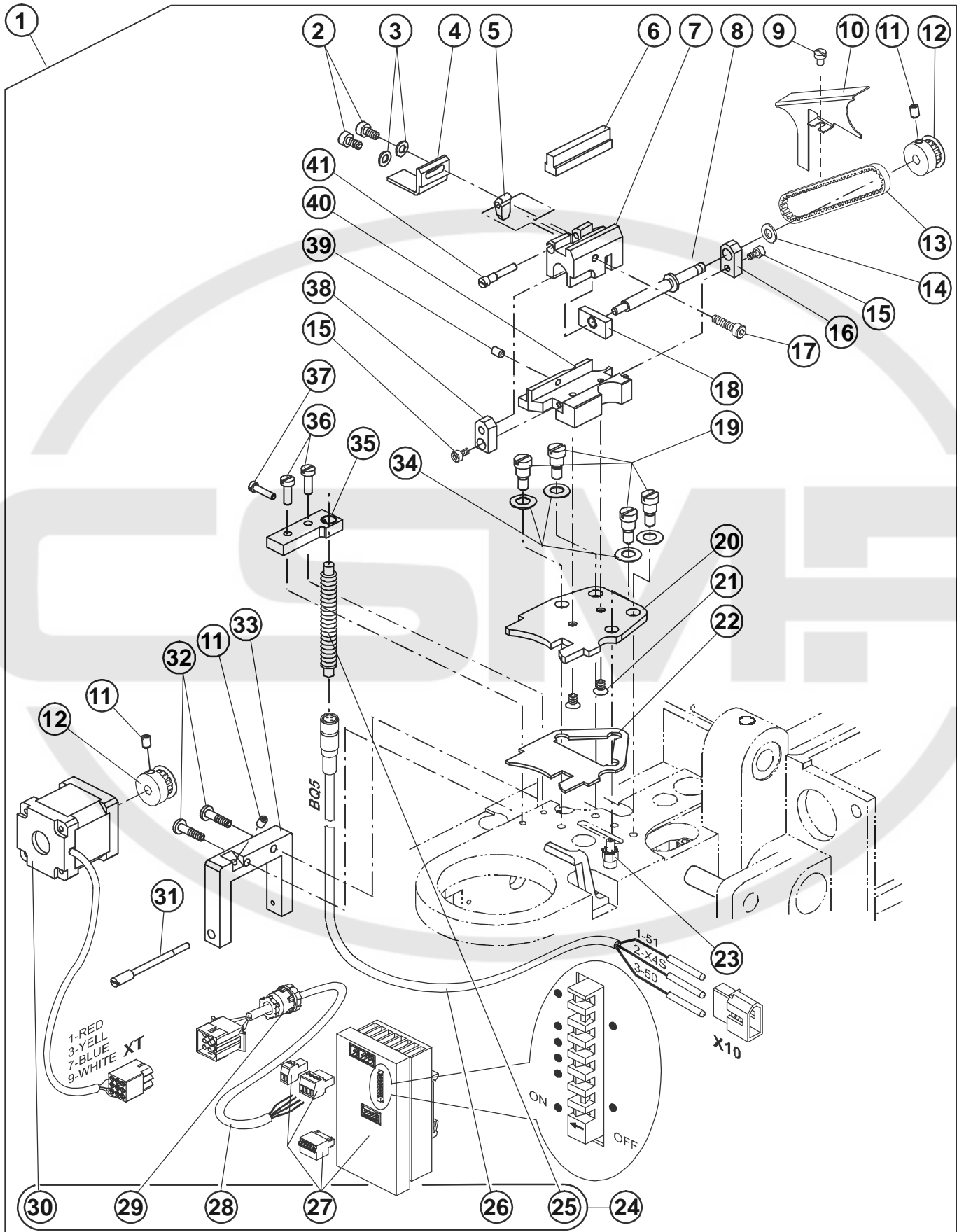

Revised 01/2007

E-mail: service@amfreece.cz; parts@amfreece.cz; website: www.amfreece.com

Phones: +420 582 309 146 (Service), +420 582 309 286 (Spare Parts); Fax: +420 582 360 606

VERSION RDE

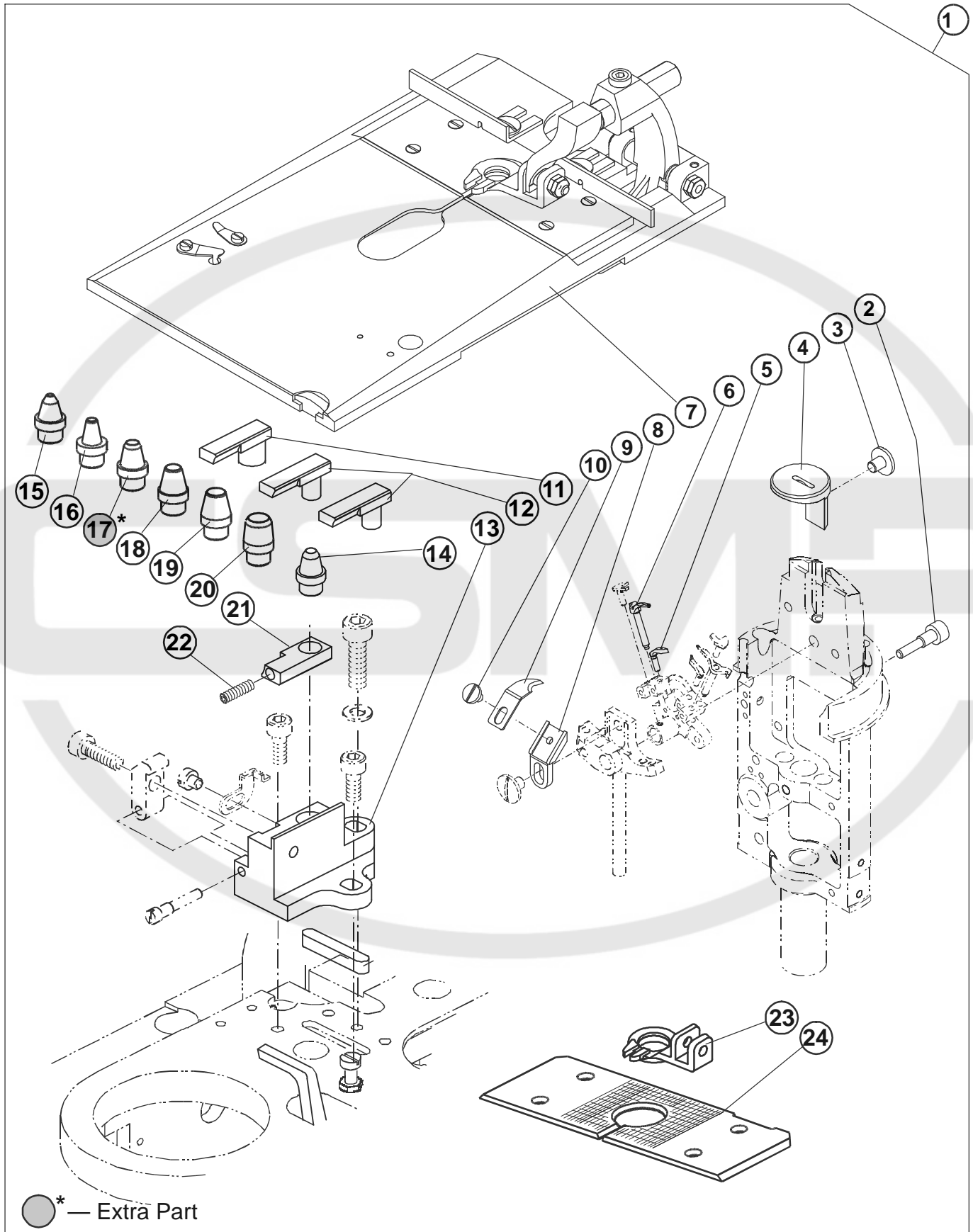

Revised 01/2007

E-mail: service@amfreece.cz; parts@amfreece.cz; website: www.amfreece.com

Phones: +420 582 309 146 (Service), +420 582 309 286 (Spare Parts); Fax: +420 582 360 606

VERSION RDE

DET	PART NUMBER	DESCRIPTION	QTY.
01	03.5519.3.050	Kit S311 RDE	1
02	19.0013.0.001	Screw	(1)
03	01.2056.1.000	Screw	(1)
04	10.4012.2.019	Throat Plate RDE	(1)
05	17.0069.4.047	Looper, Left	(1)
06	17.0004.9.893	Forked Spreader	(1)
07	19.0003.1.657	Clamps RDE	(1)
08	19.0082.3.410	Knife Holder	(1)
09	17.0087.0.204	Knife	(1)
10	17.0012.0.605	Screw	(1)
11	19.0064.5.974	Cutting Steel R7	(1)
12	19.0064.5.973	Cutting Steel R5	(2)
13	19.0074.4.537	Knife Holder RE	(1)
14	17.0042.6.086	Knife D3.5	(1)
15	17.0042.6.088	Knife D2	(1)
16	17.0042.6.090	Knife D3	(1)
17*	17.0042.6.082	Knife D4	1
18	17.0042.6.083	Knife D5	(1)
19	17.0042.6.084	Knife D6	(1)
20	17.0042.6.085	Knife D7	(1)
21	19.0064.6.493	Adapter Knife RE	(1)
22	08.6400.4.010	Screw M4x10	(1)
23	10.2552.3.006	Clamp Foot 14—15,5	(1)
24	10.2559.1.104	Clamp Mat 1/8"	(1)

* — Extra Part

Revised 01/2007

E-mail: service@amfreece.cz; parts@amfreece.cz; website: www.amfreece.com

Phones: +420 582 309 146 (Service), +420 582 309 286 (Spare Parts); Fax: +420 582 360 606

CLAMPING RDE

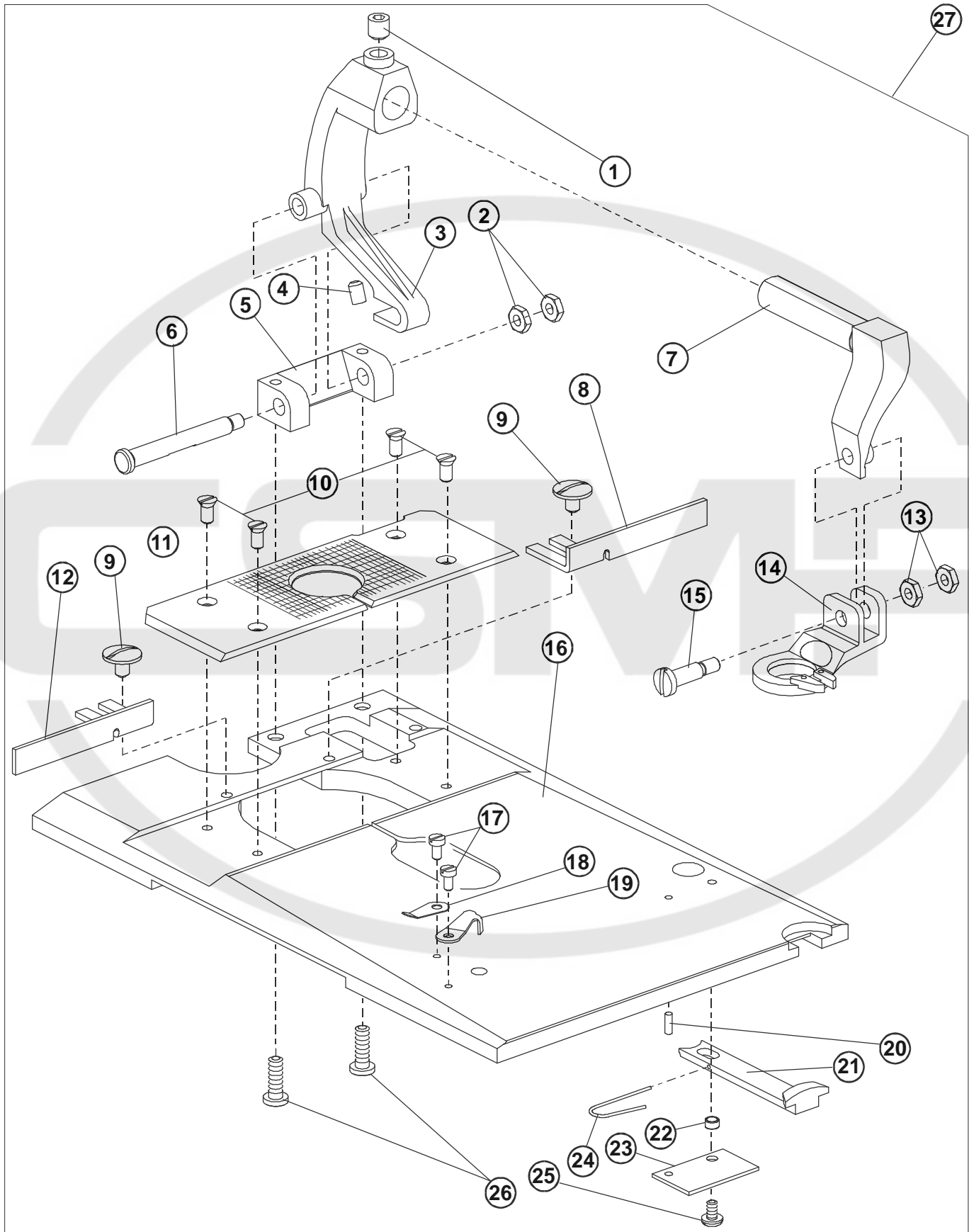

Revised 01/2007

E-mail: service@amfreece.cz; parts@amfreece.cz; website: www.amfreece.com

Phones: +420 582 309 146 (Service), +420 582 309 286 (Spare Parts); Fax: +420 582 360 606

CLAMPING RDE

DET	PART NUMBER	DESCRIPTION	QTY.
01	08.6400.6.006	Screw M6x6	(1)
02	08.6710.4.000	Nut M4	(2)
03	19.0063.5.418	Base Clamp Arm RDE	(1)
04	08.6400.4.006	Screw M4x6	(1)
05	19.0064.7.402	Block	(1)
06	19.0032.8.401	Shaft	(1)
07	19.0066.8.404	Arm Clamp RDE	(1)
08	10.2566.0.000	L.H. Gauge	(1)
09	17.0012.4.070	Screw M4x6	(2)
10	17.0012.6.400	Screw M3,5x7	(4)
11	10.2559.1.010	Clamp Mat	(1)
12	10.2567.0.000	R.H. Gauge	(1)
13	08.6700.4.000	Nut M4	(2)
14	10.2552.3.006	Clamp Foot 14 — 15,5	(1)
15	17.0013.1.485	Screw	(1)
16	19.0081.5.430	Plate RDE	(1)
17	17.0012.0.350	Screw	(2)
18	17.0082.5.884	Clip	(1)
19	17.0087.0.169	Knife	(1)
20	12.1010.0.206	Pin	(1)
21	19.0062.5.408	Pawl	(1)
22	19.0041.0.684	Ring	(1)
23	19.0081.5.449	Cover	(1)
24	19.0027.1.610	Spring	(1)
25	08.6200.3.005	Screw M4x5	(1)
26	08.6010.4.012	Screw M4x12	(2)
27	19.0003.1.657	Clamps RDE	1

Revised 01/2007

E-mail: service@amfreece.cz; parts@amfreece.cz; website: www.amfreece.com

Phones: +420 582 309 146 (Service), +420 582 309 286 (Spare Parts); Fax: +420 582 360 606

LED LIGHT

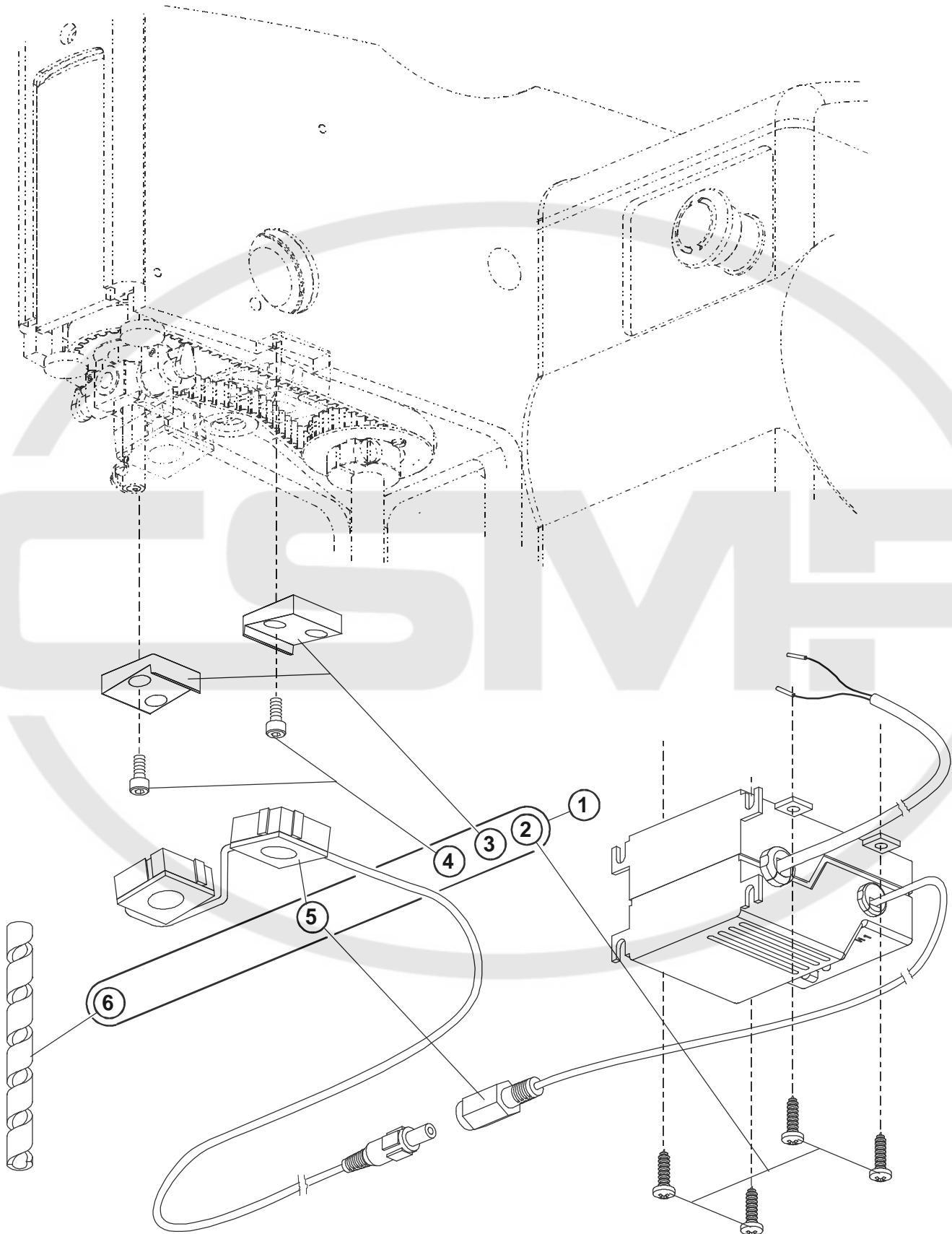

Revised 01/2007

E-mail: service@amfreece.cz; parts@amfreece.cz; website: www.amfreece.com
Phones: +420 582 309 146 (Service), +420 582 309 286 (Spare Parts); Fax: +420 582 360 606

LED LIGHT

DET	PART NUMBER	DESCRIPTION	QTY.
01	03.5519.3.002	LED Light Assembly	1
02	08.6632.3.016	Screw	(4)
03	19.0064.8.443	Holder Leds Diodes	(1)
04	08.6000.4.005	Screw	(2)
05	19.0007.9.038	LED Light Kit	(1)
06	12.0008.4.141	Flexible Tubing	(1)
			

Revised 01/2007

E-mail: service@amfreece.cz; parts@amfreece.cz; website: www.amfreece.com

Phones: +420 582 309 146 (Service), +420 582 309 286 (Spare Parts); Fax: +420 582 360 606

TOOLS/ACCESSORIES

STANDARD

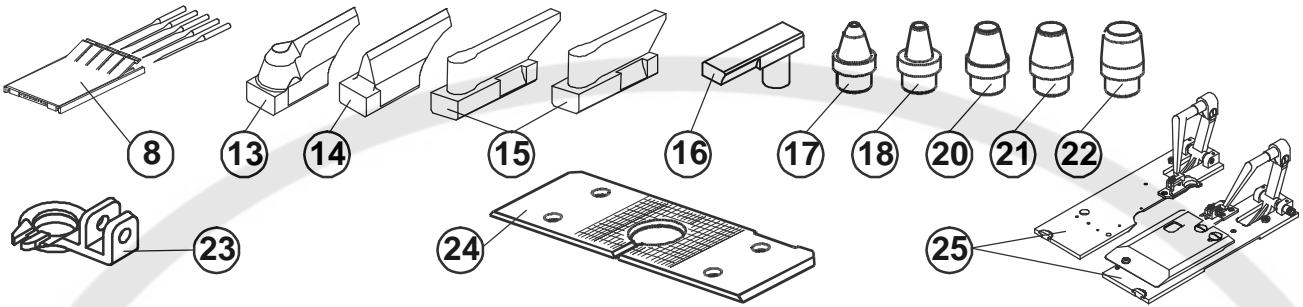
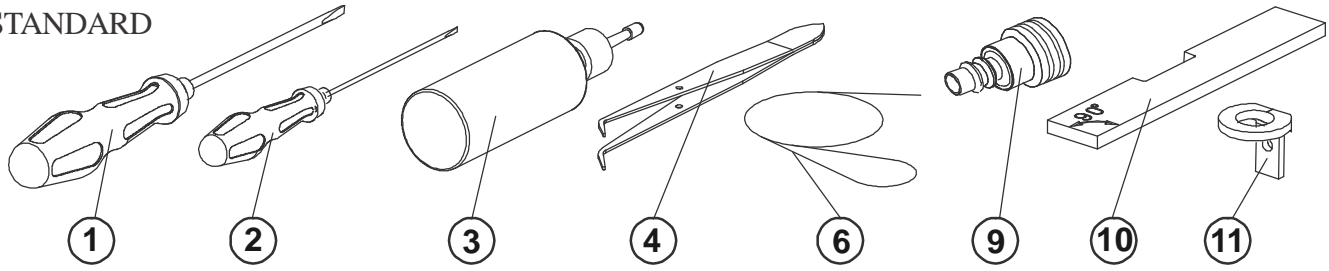

	DET.	PART NUMBER	DESCRIPTION	MODIFICATION												NOTE			
				AF	CT 16-20	CT 20-24	CT 24-28	CT 28-32	CT 16-32	LTT	AF/ACL	CT/ACL 16-20	CT/ACL 20-24	CT/ACL 24-28	CT/ACL 28-32		LTT/ACL	RDE	
STANDARD	01	12.0008.6.005	Screwdriver 5,5-180	1	1	1	1	1	1	1	1	1	1	1	1	1	1		
	02	12.0008.6.001	Screwdriver RECA	1	1	1	1	1	1	1	1	1	1	1	1	1	1		
	03	05.1322.0.000	Oil Can	1	1	1	1	1	1	1	1	1	1	1	1	1	1		
	04	12.0008.6.215	Tweezers	1	1	1	1	1	1	1	1	1	1	1	1	1	1		
	06	17.0027.1.223	Thread Wire	1	1	1	1	1	1	1	1	1	1	1	1	1	1		
	09	12.0008.3.608	Connector Dia 10	1	1	1	1	1	1	1	1	1	1	1	1	1	1		
	10	19.0081.6.412	Timing Gauge	1	1	1	1	1	1	1	1	1	1	1	1	1	1		
	11	19.0064.7.420	Timing Gauge	1	1	1	1	1	1	1	1	1	1	1	1	1	1		
	BY MODEL	08	02.0558.0.111	Needles 558 Nm 100	5						5	5					5	5	w ith cover
		08	02.0558.1.112	Needles 558 Nm 110		5	5	5	5	5			5	5	5	5			w ith cover
		13	19.0087.0.432	Eye Knife 28/42 - 38	1	1	1	1	1	1	1	1	1	1	1	1	1	1	
		19.0087.0.439	Knife 34x42 - 38	1							1	1					1		
14		17.0064.5.863	No Eye Knife 38	1							1								
15		19.0064.5.849	Cutting Steel 16T	1					1	1									
		19.0064.5.851	Cutting Steel 20T		1	1			1										
		19.0064.5.952	Cutting Steel 19T		1														
		19.0064.5.852	Cutting Steel 22T	1						1									
		19.0064.5.853	Cutting Steel 24T			1	1												
		19.0064.5.854	Cutting Steel 26T	1						1									
		19.0064.5.855	Cutting Steel 29T					1			1								
		19.0064.5.856	Cutting Steel 32T	1					1	1									
16		19.0064.5.974	Cutting Steel 7R															1	
17		17.0042.6.088	Knife D2															1	
18		17.0042.6.090	Knife D3															1	
20		17.0042.6.083	Knife D5															1	
21		17.0042.6.084	Knife D6															1	
22		17.0042.6.085	Knife D7															1	
23		10.2552.3.006	Clamp Foot 14-15,5															1	
24	10.2559.1.104	Clamp Mat 1/8" H															1		
25	19.0003.1.662	Clamps CT 20 - 24							1										
	19.0003.1.663	Clamps CT 24 - 28							1										
	19.0003.1.664	Clamps CT 28 - 32							1										

Revised 01/2007

E-mail: service@amfreece.cz; parts@amfreece.cz; website: www.amfreece.com

Phones: +420 582 309 146 (Service), +420 582 309 286 (Spare Parts); Fax: +420 582 360 606

AMF[®] REECE

Better Ideas, Better Made

MODEL S-311+I

**ELECTRONIC EYELET BUTTONHOLE
MACHINE**

INDEXER PARTS

MACHINE SERIAL No.

PART NUMBER 97. 1930.0.001

BASE AND CLAMP

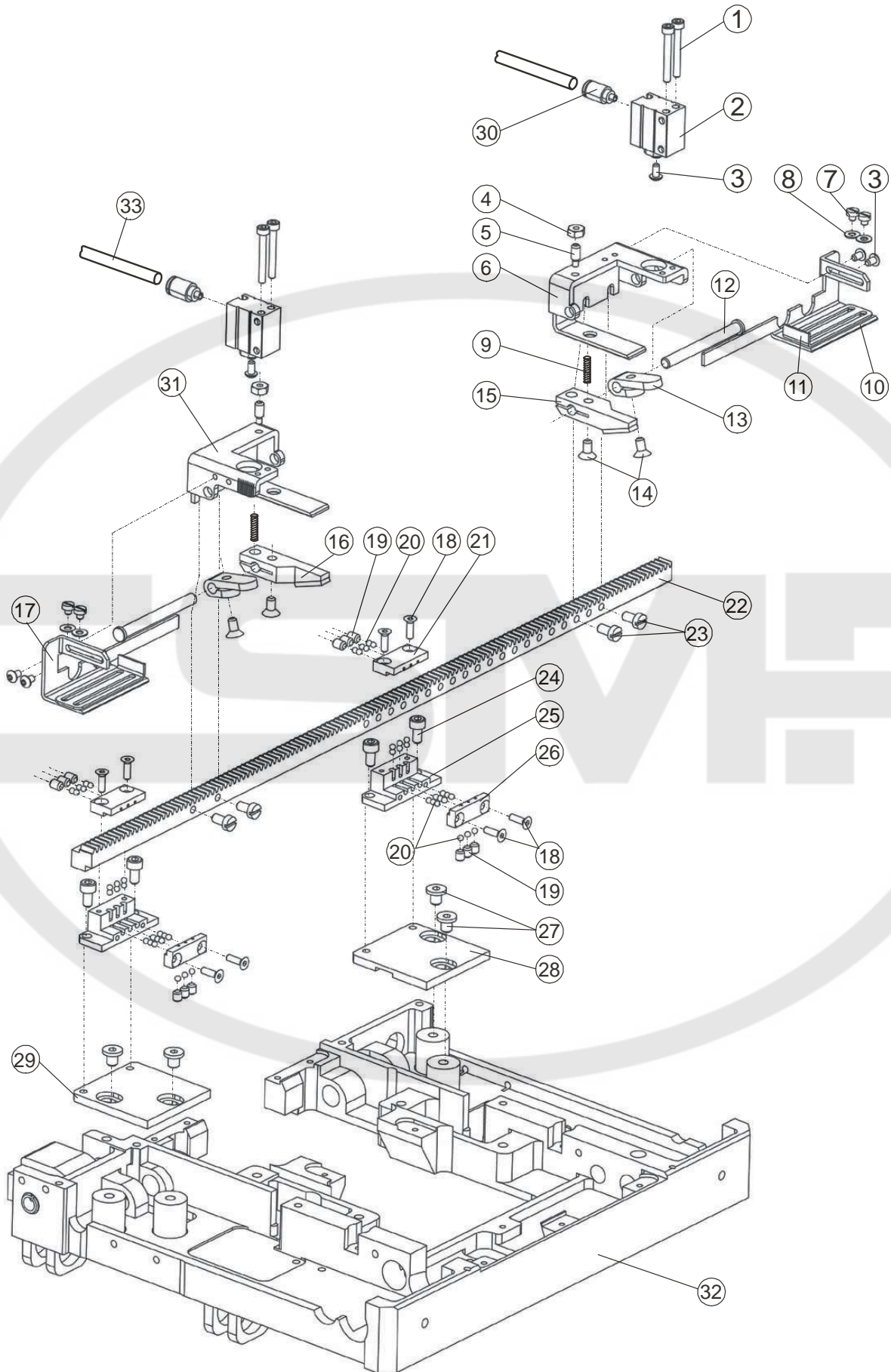

Revised 01/2007

BASE AND CLAMP

DET	PART NUMBER	DESCRIPTION	QTY.
01	08.6000.3.025	Screw	2
02	12.0008.3.729	Cylinder	2
03	08.6200.3.005	Screw	6
04	08.6700.4.000	Nut	2
05	19.0011.2.403	Spring Screw	2
06	19.0005.0.022	Cylinder Bracket Right	1
07	08.6012.3.003	Screw	4
08	08.6852.3.000	Washer	4
09	17.0026.1.084	Spring	2
10	19.0082.6.450	Front Gauge-Right(Jacket)	1
11	19.0082.6.448	Gauge	2
12	19.0032.0.403	Stud	2
13	19.0064.6.508	Lever	2
14	08.6100.4.008	Screw	4
15	19.0064.6.506	Clamp Foot Right	1
16	19.0064.6.507	Clamp Foot Left	1
17	19.0082.6.451	Front Gauge-Left(Jacket)	1
18	08.6100.3.010	Screw	8
19	08.6400.4.004	Screw	12
20	12.2099.1.000	Ball	48
21	19.0064.6.510	Carriage Cover-Upper	1
22	19.0064.7.429	Clamp Rack	1
23	08.6010.4.008	Screw	4
24	08.6000.4.008	Screw	4
25	19.0064.6.509	Carriage Base	2
26	19.0064.6.512	Carriage Cover-Lower	2
27	08.6050.5.006	Screw	4
28	19.0082.6.445	Left Bracket	1
29	19.0082.6.446	Right Bracket	1
30	12.0008.3.409	Connector	2
31	19.0005.0.021	Cylinder Bracket Left	1
32	19.0071.4.206	Bedplate	1
33	19.0094.2.414	Air Tubing	1

Revised 01/2007

e-mail: service@amfreece.cz; parts@amfreece.cz; website: www.amfreece.com

Phones: +420 582 309 146 (Service), +420 582 309 286 (Spare Parts); Fax: +420 582 360 606

POWER

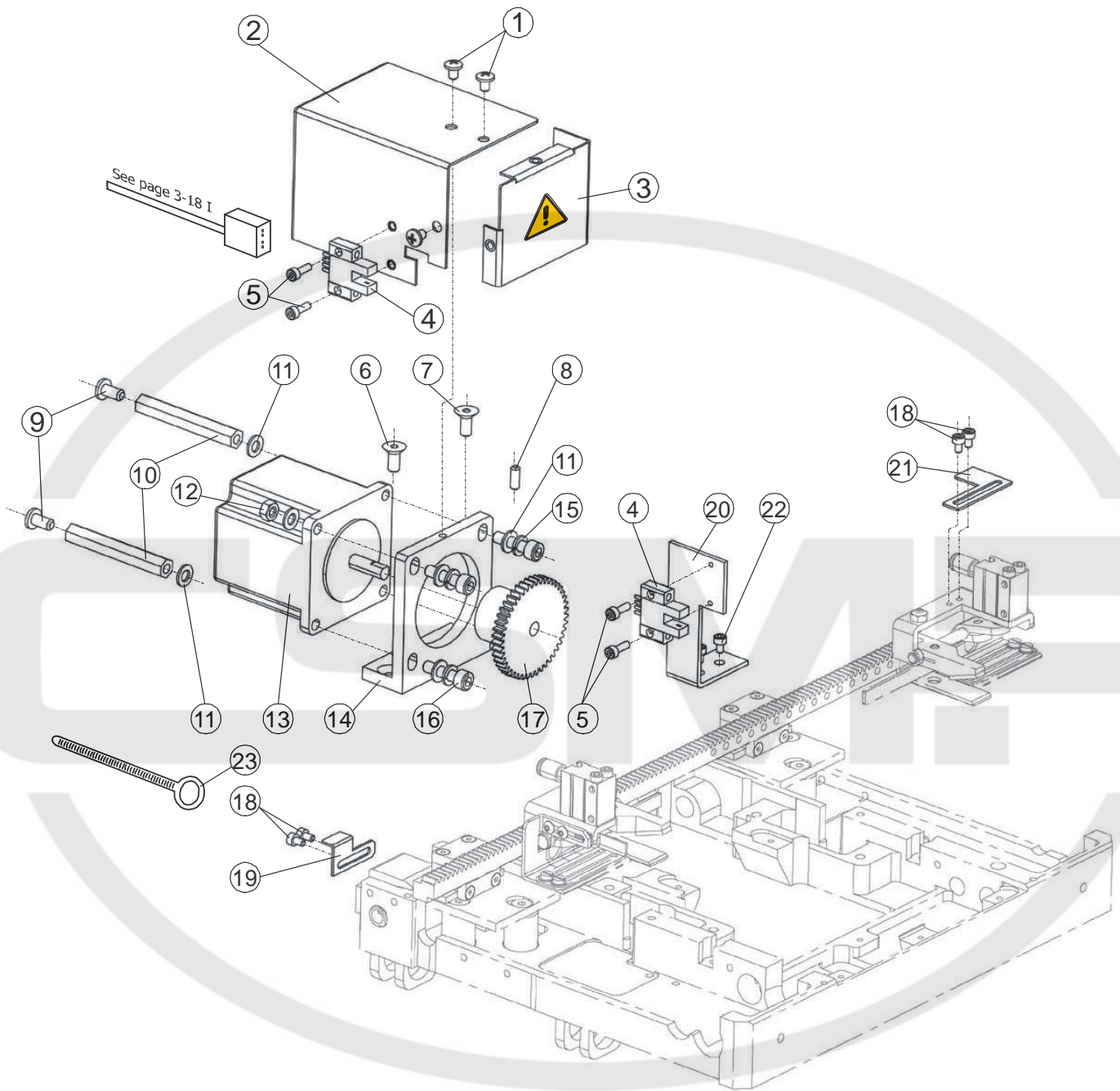

COVERS

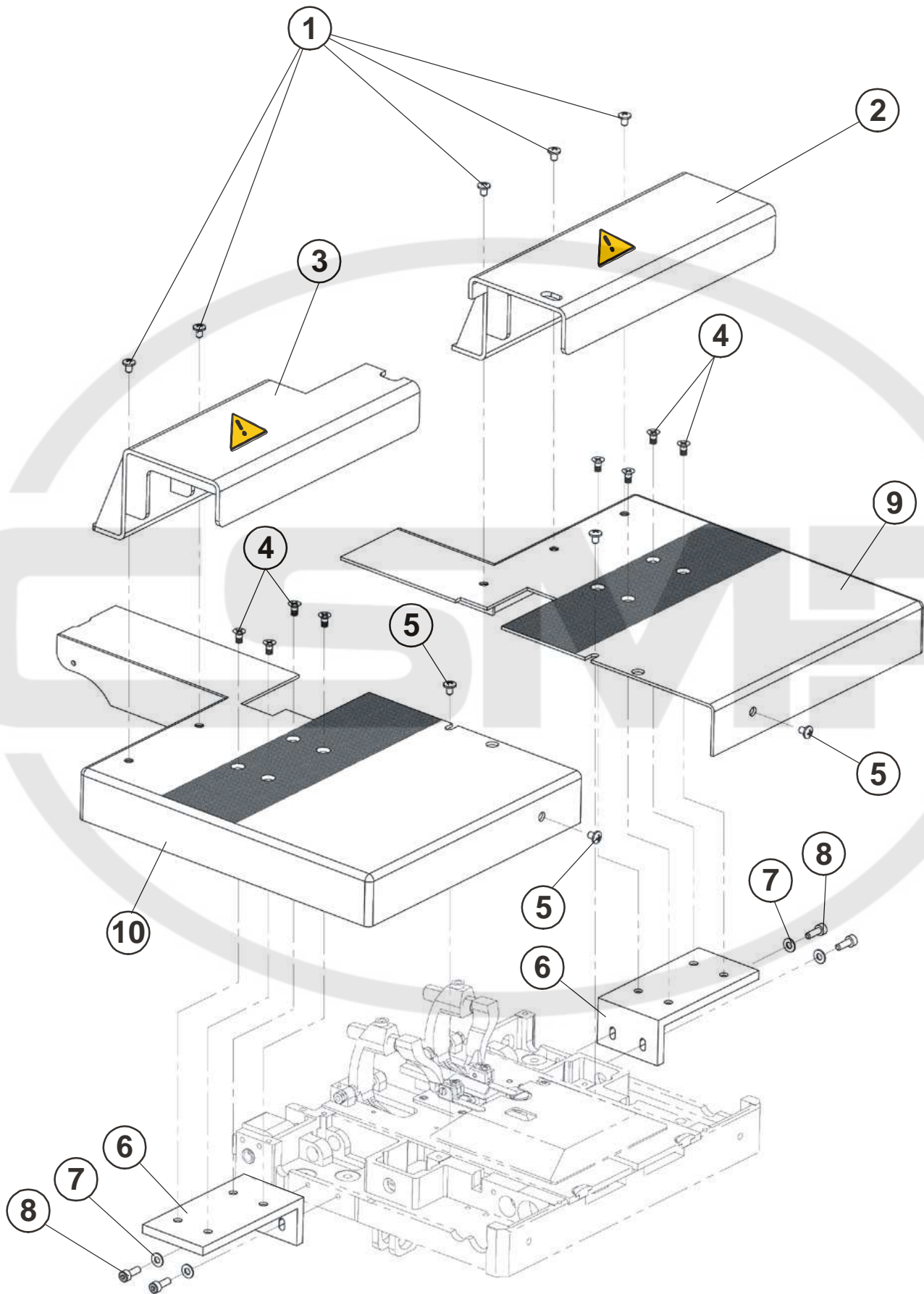

Revised 01/2007

CLAMPING - AF+I

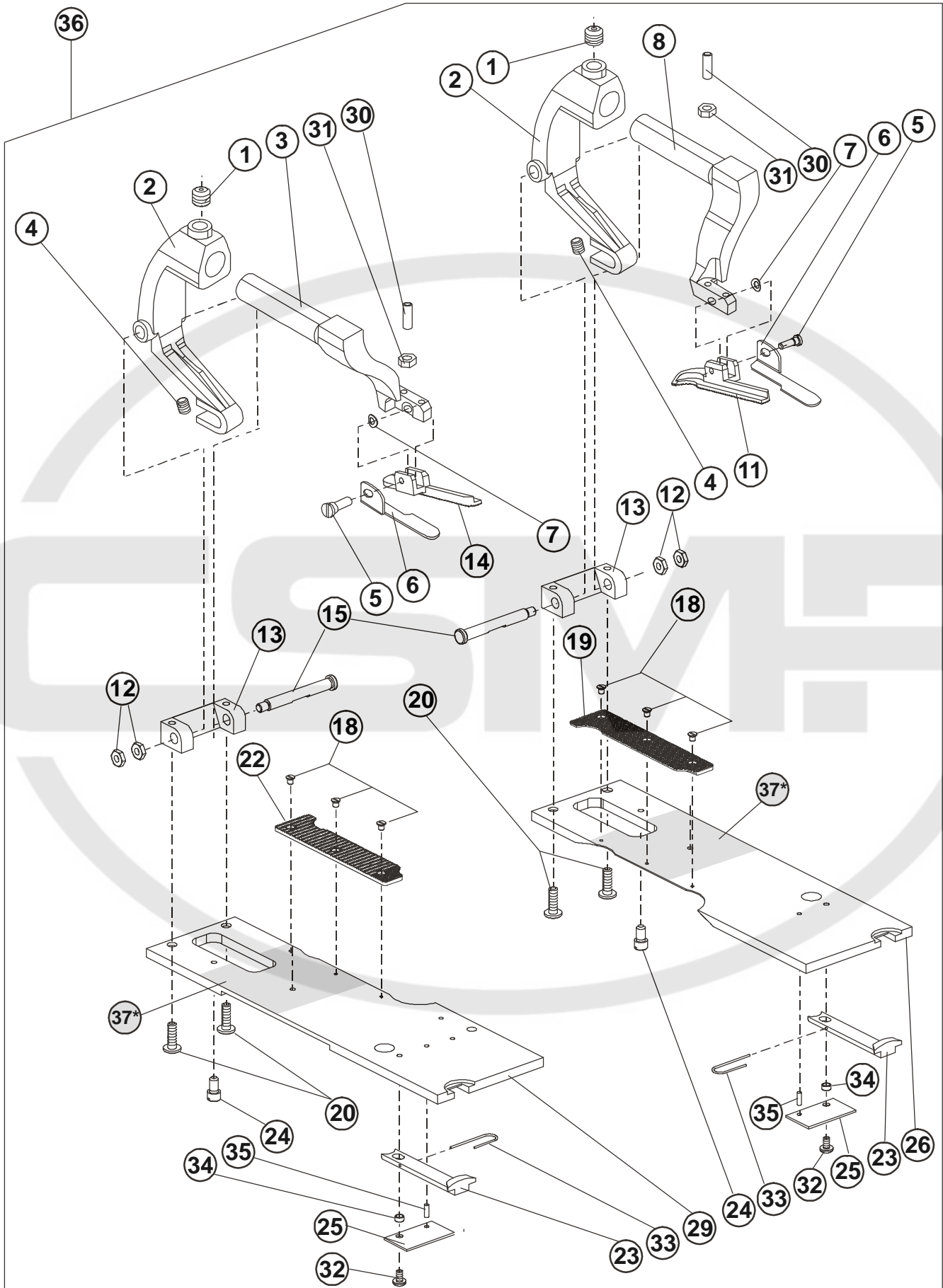

Revised 01/2007

CLAMPING - CT+I

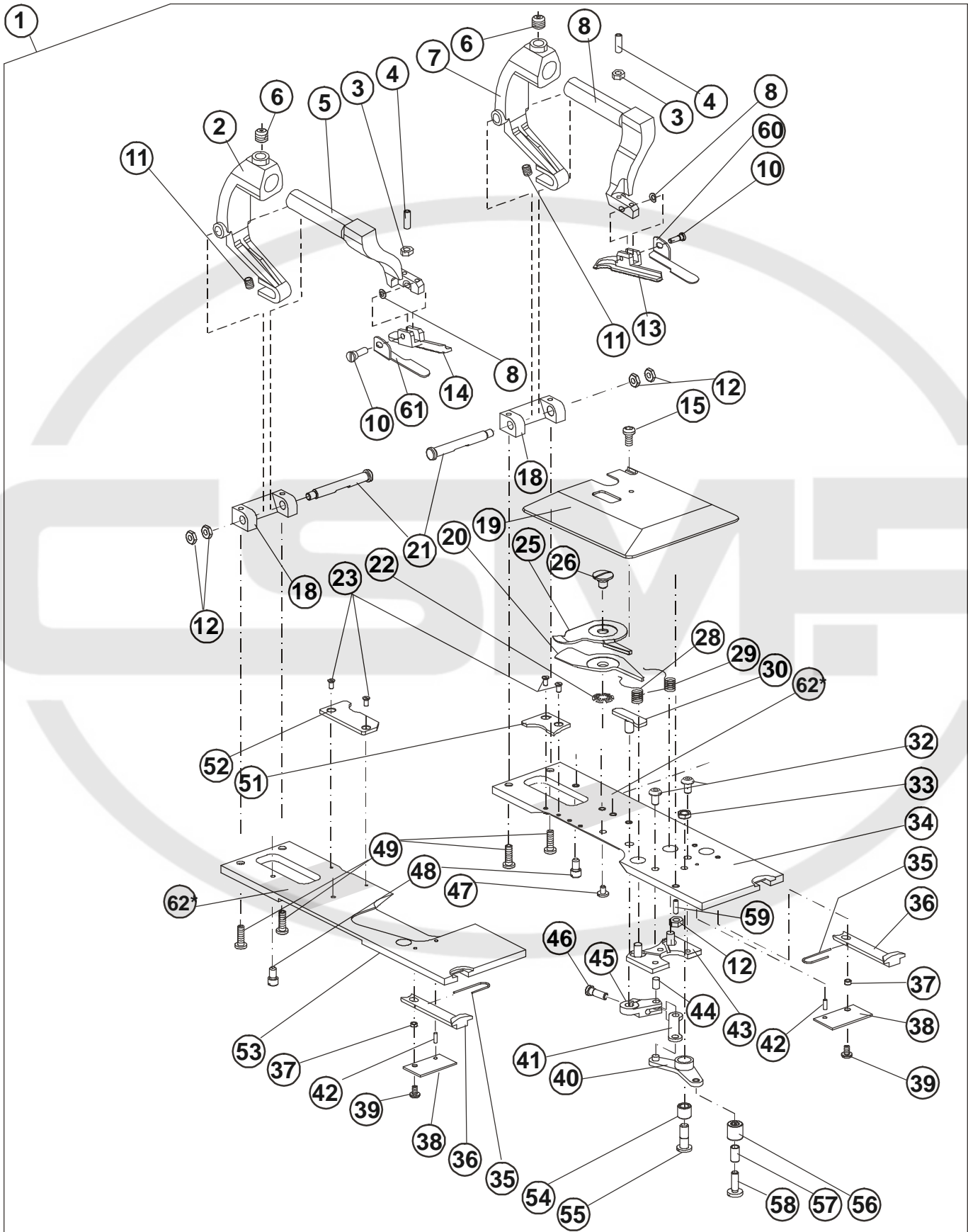

Revised 01/2007

CLAMPING - CT+I

DET	PART NUMBER	DESCRIPTION	QTY.
01	19.0003.1.671	Modification (16—20) Jacket	
	19.0003.1.681	Modification (16 - 20) Jeans	
02	19.0063.5.418	Clamp Arm Base	2
03	08.6710.3.000	Nut	2
04	08.6400.3.010	Screw	2
05	19.0066.8.405	L.H. Clamp Arm	1
06	08.6400.6.006	Screw	
07	19.0066.8.406	R.H. Clamp Arm	1
08	17.0019.2.066	Curved Spring Washer	2
10	17.0013.5.067	Screw	2
11	08.6400.4.006	Screw	2
12	08.6710.4.000	Nut	5
13	18.0066.7.410	R.H. Clamp Foot Jacket	1
13	19.0066.7.424	R.H. Clamp Foot Jeans	1
14	18.0066.7.411	L.H. Clamp Foot Jacket	1
14	19.0066.7.425	L.H. Clamp Foot Jeans	1
15	08.6200.4.006	Screw	1
17	17.0012.4.106	Screw	2
18	19.0064.7.402	Block	2
19	19.0074.6.221	Cover Plate	1
20	19.0087.0.428	Lower Shear	1
21	19.0032.8.401	Screw	2
22	12.3013.0.002	Washer	1
23	17.0012.3.054	Screw	4
25	19.0087.0.425	Upper Shear	1
26	19.0013.1.498	Pivot Screw	1
27	19.0082.6.421	L.H. Cloth Gauge	1
28	17.0026.4.065	L.H. Spring	1
29	17.0026.4.064	R.H. Spring	1
30	19.0062.5.404	Actuator	1
32	17.0012.4.103	Screw	2
33	17.0016.1.054	Nut	1
34	19.0081.5.462	R.H. Plate	1
35	19.0027.1.610	Spring	2
36	19.0062.5.408	Pawl	2
37	19.0041.0.684	Ring	2
38	19.0081.5.449	Cover	2
39	08.6200.3.005	Screw	2
40	19.0063.3.402	Lever	1
41	19.0081.0.512	Lever	1
42	12.1010.0.206	Pin	2
43	19.0005.2.212	Actuator	1
44	12.1010.0.408	Pin	1
45	19.0061.3.605	Lower Lever	1
46	17.0012.0.543	Screw	1
47	17.0012.0.605	Screw	1
48	19.0033.1.404	Screw	2
49	08.6010.4.012	Screw	4

Revised 01/2007

e-mail: service@amfreece.cz; parts@amfreece.cz; website: www.amfreece.com

Phones: +420 582 309 146 (Service), +420 582 309 286 (Spare Parts); Fax: +420 582 360 606

CLAMPING - CT+I

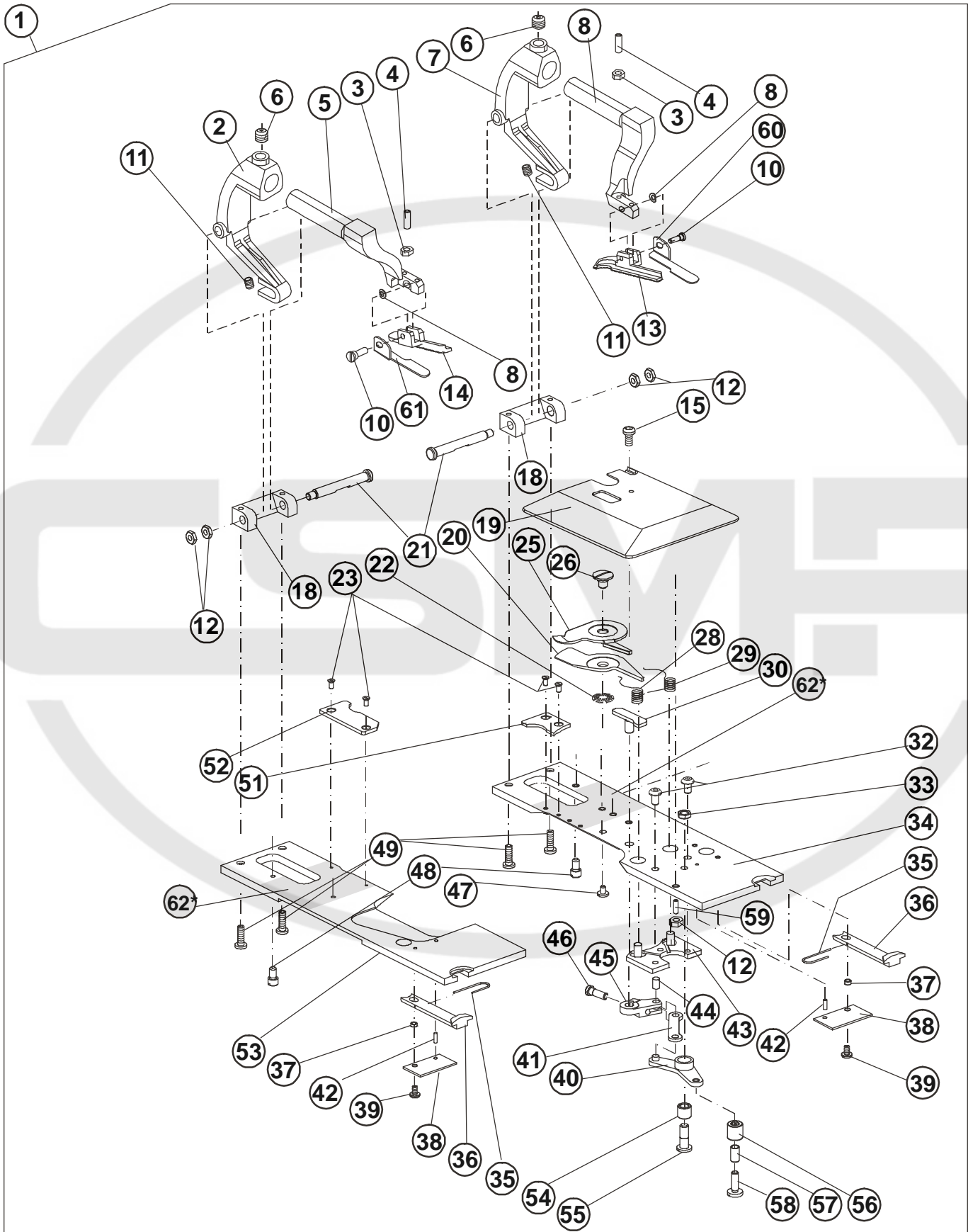

Revised 01/2007

CLAMPING - CT+I

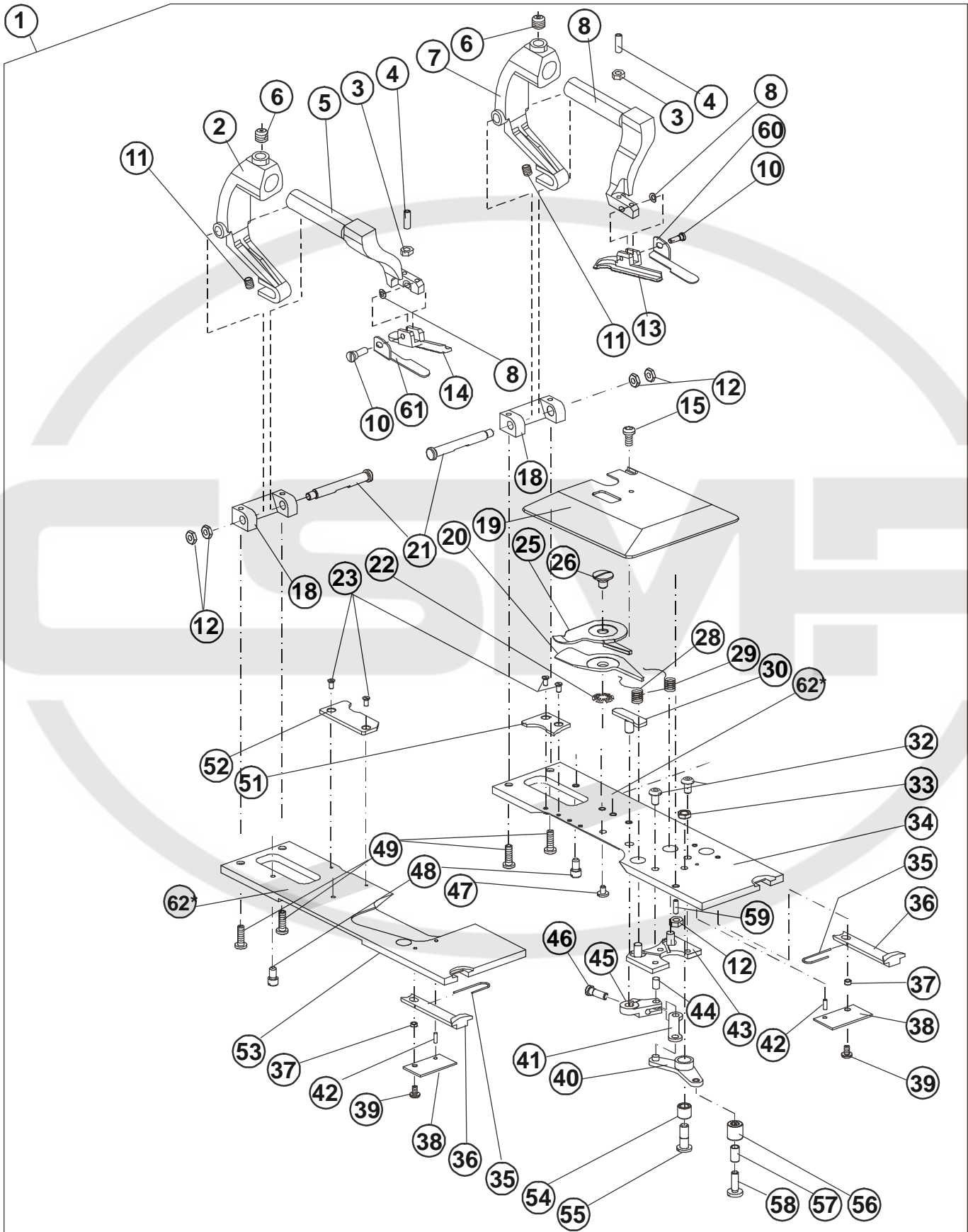

Revised 01/2007

CLAMPING - CT+I

DET	PART NUMBER	DESCRIPTION	QTY.
01	19.0003.1.682	Modification (20—24) Jeans	
02	19.0063.5.418	Clamp Arm Base	2
03	08.6710.3.000	Nut	2
04	08.6400.3.010	Screw	2
05	19.0066.8.405	L.H. Clamp Arm	1
06	08.6400.6.006	Screw	
07	19.0066.8.406	R.H. Clamp Arm	1
08	17.0019.2.066	Curved Spring Washer	2
10	17.0013.5.067	Screw	2
11	08.6400.4.006	Screw	2
12	08.6710.4.000	Nut	5
13	19.0066.7.412	R.H. Clamp Foot Jeans	1
14	19.0066.7.413	L.H. Clamp Foot Jacket	1
15	08.6200.4.006	Screw	1
18	19.0064.7.402	Block	2
19	19.0074.6.221	Cover Plate	1
20	19.0087.0.428	Lower Shear	1
21	19.0032.8.401	Screw	2
22	12.3013.0.002	Washer	1
23	17.0012.3.054	Screw	4
25	19.0087.0.425	Upper Shear	1
26	19.0013.1.498	Pivot Screw	1
28	17.0026.4.065	L.H. Spring	1
29	17.0026.4.064	R.H. Spring	1
30	19.0062.5.404	Actuator	1
32	17.0012.4.103	Screw	2
33	17.0016.1.054	Nut	1
34	19.0081.5.464	R.H. Plate	1
35	19.0027.1.610	Spring	2
36	19.0062.5.408	Pawl	2
37	19.0041.0.684	Ring	2
38	19.0081.5.449	Cover	2
39	08.6200.3.005	Screw	2
40	19.0063.3.402	Lever	1
41	19.0081.0.512	Lever	1
42	12.1010.0.206	Pin	2
43	19.0005.2.212	Actuator	1
44	12.1010.0.408	Pin	1
45	19.0061.3.605	Lower Lever	1
46	17.0012.0.543	Screw	1
47	17.0012.0.605	Screw	1
48	19.0033.1.404	Screw	2
49	08.6010.4.012	Screw	4
51	18.0081.1.404	R.H. Clamp Mat	1
52	18.0081.1.403	L.H. Clamp Mat	1
53	19.0081.5.447	L.H. Plate	1
54	19.0044.1.626	Roll	1
55	19.0012.1.404	Screw	1
56	12.2050.1.005	Needle Bearing	1
57	19.0041.1.400	Roll	1
58	17.0012.1.142	Screw	1
59	08.6490.4.009	Screw	1
60	19.0081.5.472	Holder Cloth - Right	1
61	19.0081.5.473	Holder Cloth - Left	1
62*	12.0008.6.981	Teflon Tape	
*	— Extra Part		

Revised 01/2007

e-mail: service@amfreece.cz; parts@amfreece.cz; website: www.amfreece.com

Phones: +420 582 309 146 (Service), +420 582 309 286 (Spare Parts); Fax: +420 582 360 606

TABLE

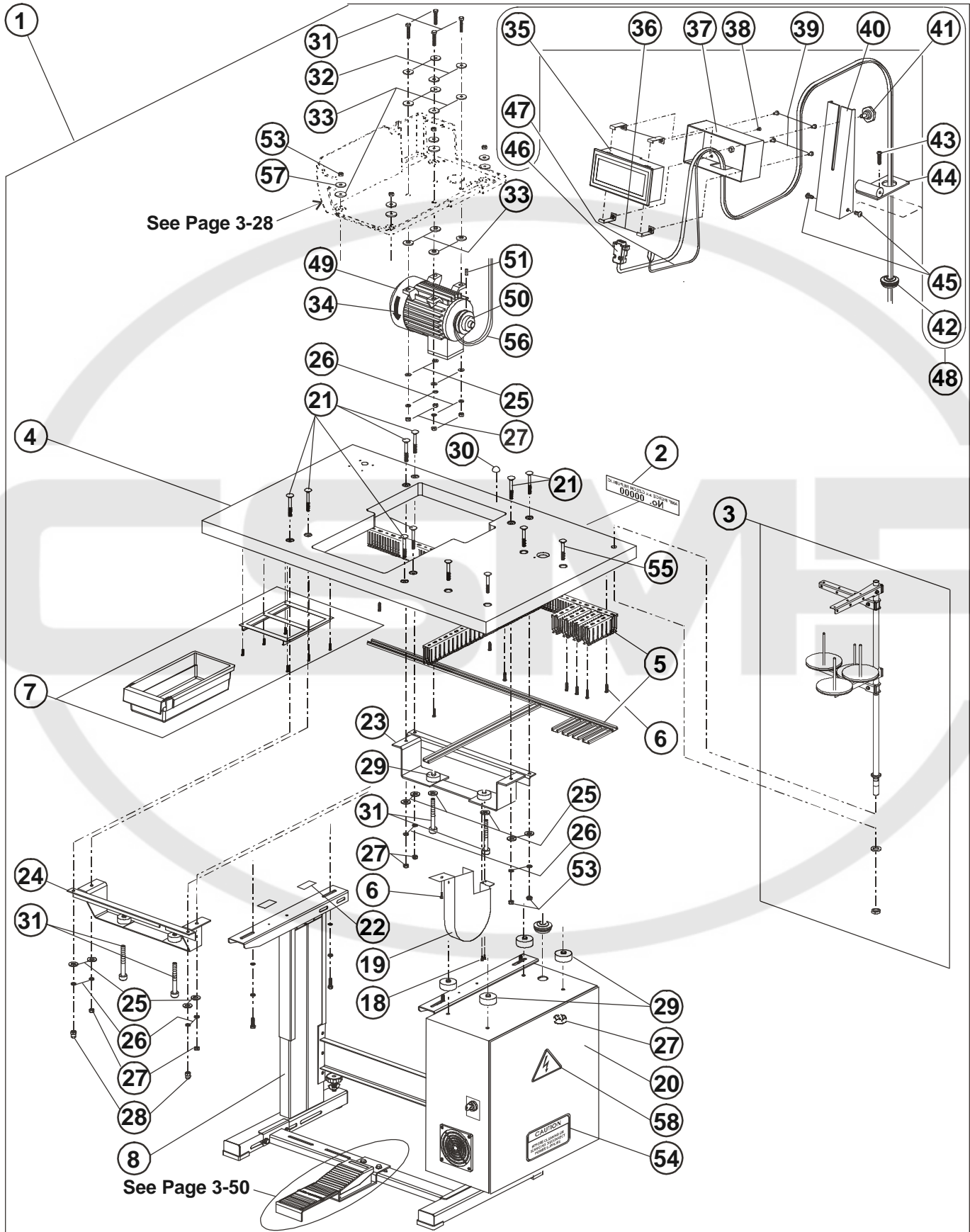

Revised 01/2007

TABLE

DET	PART NUMBER	DESCRIPTION	QTY.
01	03.5519.1.091	Table Assembly	1
02	04.1416.0.003	Label "No. xxxxx" ●●●	1
03	17.0003.6.156	Thread Stand Assembly	1
04	19.0091.0.402	Table Top ●●●	1
05	19.0095.2.403	Latch for Cable Kit ●●●	1
06	08.6632.3.016	Screw	15
07	12.0008.6.901	Drawer Kit ●●●	1
08	04.9000.2.123	Frame Kit	1
18	08.6000.4.008	Screw	2
19	19.0005.0.028	Cover Pulley ●●●	1
20	19.0006.9.448	Electrical Box Assembly ▫	1
21	08.6532.8.050	Screw	8
22	17.0094.0.200	Washer	4
23	19.0005.0.016	Framework	1
24	19.0005.0.015	Framework	1
25	08.6852.8.000	Washer	12
26	08.6802.8.000	Spring Washer	12
27	08.6702.8.000	Nut	14
28	08.6722.8.000	Nut	2
29	19.0095.1.405	Rubber Washer	8
30	12.0008.6.915	Holder	1
31	08.6312.8.040	Screw	8
32	01.4750.0.000	Washer	4
33	17.0095.1.272	Rubber Washer	12
34	17.0097.5.182	Label	1
35	19.8001.1.105	Display	(1)
36	19.0005.0.012	Panel Holder Got	(4)
37	19.0005.0.011	Display Box	(1)
38	08.6000.3.005	Screw	(1)
39	08.6032.4.010	Screw	(4)
40	19.0083.7.002	Display Box Holder	(1)
41	24.4019.0.000	Screw	(1)
42	12.0008.4.366	Bushing	(1)
43	08.6663.5.025	Screw	(1)
44	19.0005.0.013	Panel Stand Base	(1)
45	08.6200.6.010	Screw	(2)
46	12.0008.4.821	Cable	(1)
47	19.0007.9.477	Cable	(1)
48	03.5519.0.003	Touch Screen Assembly	1
49	12.0008.4.757	Motor	1
50	19.0052.0.501	Puley	1
51	08.6400.6.006	Screw M6x6	1
53	08.6733.8.000	M8 Nut Lock	4
54	00.2751.3.602	Label	1
55	08.6532.8.070	Screw	4
56	12.5050.1.501	Belt	1
57	17.0019.0.441	Washer	4
58	17.0097.5.174	Label	1

Revised 01/2007

e-mail: service@amfreece.cz; parts@amfreece.cz; website: www.amfreece.com

Phones: +420 582 309 146 (Service), +420 582 309 286 (Spare Parts); Fax: +420 582 360 606

ELECTRONIC BOX-ELECTRONIC PARTS -I

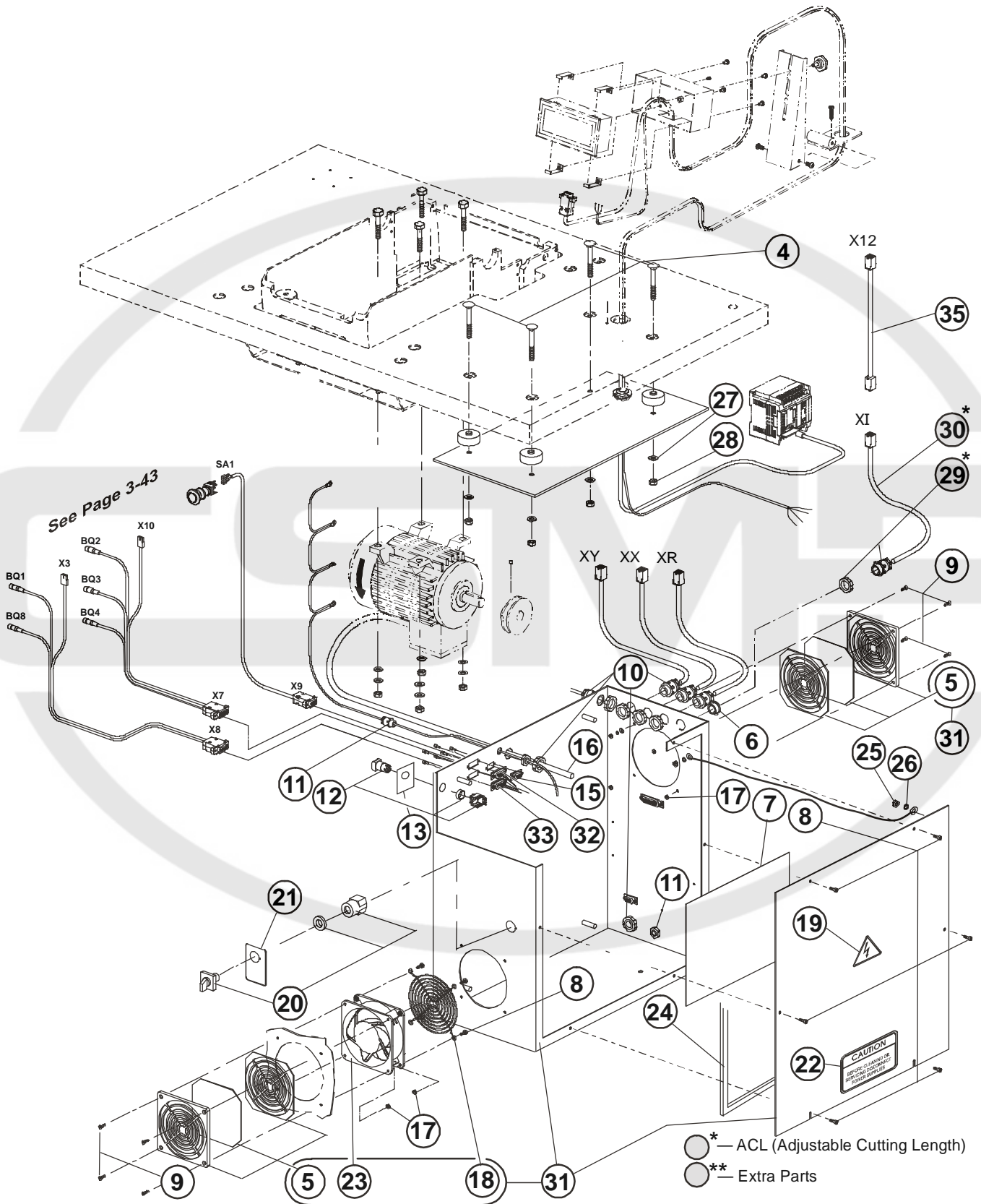

Revised 01/2007

ELECTRONIC BOX-ELECTRONIC PARTS -I

DET	PART NUMBER	DESCRIPTION	QTY.
04	08.6532.8.070	Screw	4
05	12.0008.4.761	Fan Cover With Filter	(2)
06	12.0008.4.777	Stopper	1
07	12.8000.0.077	Electrical Diagram Label	1
08	08.6032.4.012	Screw	14
09	08.6032.4.016	Screw	4
10	12.0008.4.231	Bushing	6
11	12.0008.4.207	Bushing	2
12	12.0008.4.613	Pushbutton (Green)	1
13	12.0008.4.615	Switch Unit (ZB6-E2B)	(1)
15	19.0007.9.023	Cable X9A	1
16	19.0007.9.008	Sew Motor	1
17	08.6702.4.000	Nut	12
18	12.0008.4.691	Fan Rack	(1)
19	12.0008.4.378	Label	1
20	12.0008.4.716	Knob	1
21	12.8000.0.423	Label	1
22	00.2751.3.602	Label "CAUTION"	1
23	12.0008.4.682	Fan	(1)
24	19.0094.2.410	Gasket	1
25	08.6702.6.000	Nut	2
26	08.6832.6.000	Washer	2
27	08.6852.8.000	Washer	4
28	08.6702.8.000	Nut	4
29*	12.0008.4.231	Bushing	1*
30*	19.0007.9.011	Cable Motor	1*
31	19.0005.0.014	Driving Box	1
32	19.0007.9.021	Cable X7A	1
33	19.0007.9.022	Cable X8A	1
35	19.0007.9.041	Junction Cable	1

* — ACL (Adjustable Cutting Length)

* — Extra Part

Revised 01/2007

e-mail: service@amfreece.cz; parts@amfreece.cz; website: www.amfreece.com

Phones: +420 582 309 146 (Service), +420 582 309 286 (Spare Parts); Fax: +420 582 360 606

ELECTRONIC BOX-ELECTRONIC PARTS -II

DET	PART NUMBER	DESCRIPTION	QTY.
03	12.0008.4.885	Cable Flexo	1
04	12.0008.4.710	Screw Kit	5
05	19.0007.9.028	cABLE X11A	1
06	19.0007.9.018	Cable X4A	1
07	19.0007.9.019	Cable X5A	1
08	19.0007.9.037	Pedal Assembly	1
09	12.0008.4.204	Pedal	●●● (1)
10	12.0008.4.296	Bushing	●●● (1)
11	19.0007.9.036	Cable	(1)
12	08.6312.8.020	Screw	(2)
13	08.6852.8.000	Washer	(4)
14	24.0097.0.000	Holder Pedal	(1)
15	08.6100.4.012	Screw	(4)
16	08.6802.8.000	Spring Washer	(2)
17	08.6702.8.020	Screw	(2)
18	08.6662.4.010	Screw	2
19	19.0083.1.687	Cover	1
20	19.0014.6.408	Distance Nut	1
21	08.6010.4.008	Screw	2
22	08.6702.4.000	Nut	1
23	08.6852.4.000	Washer	2
24	08.6832.4.000	Washer Serated	1
25	19.0007.9.029	Cable X11	1

Revised 01/2007

e-mail: service@amfreece.cz; parts@amfreece.cz; website: www.amfreece.com

Phones: +420 582 309 146 (Service), +420 582 309 286 (Spare Parts); Fax: +420 582 360 606

ELECTRONIC BOX-ELECTRONIC PARTS -III

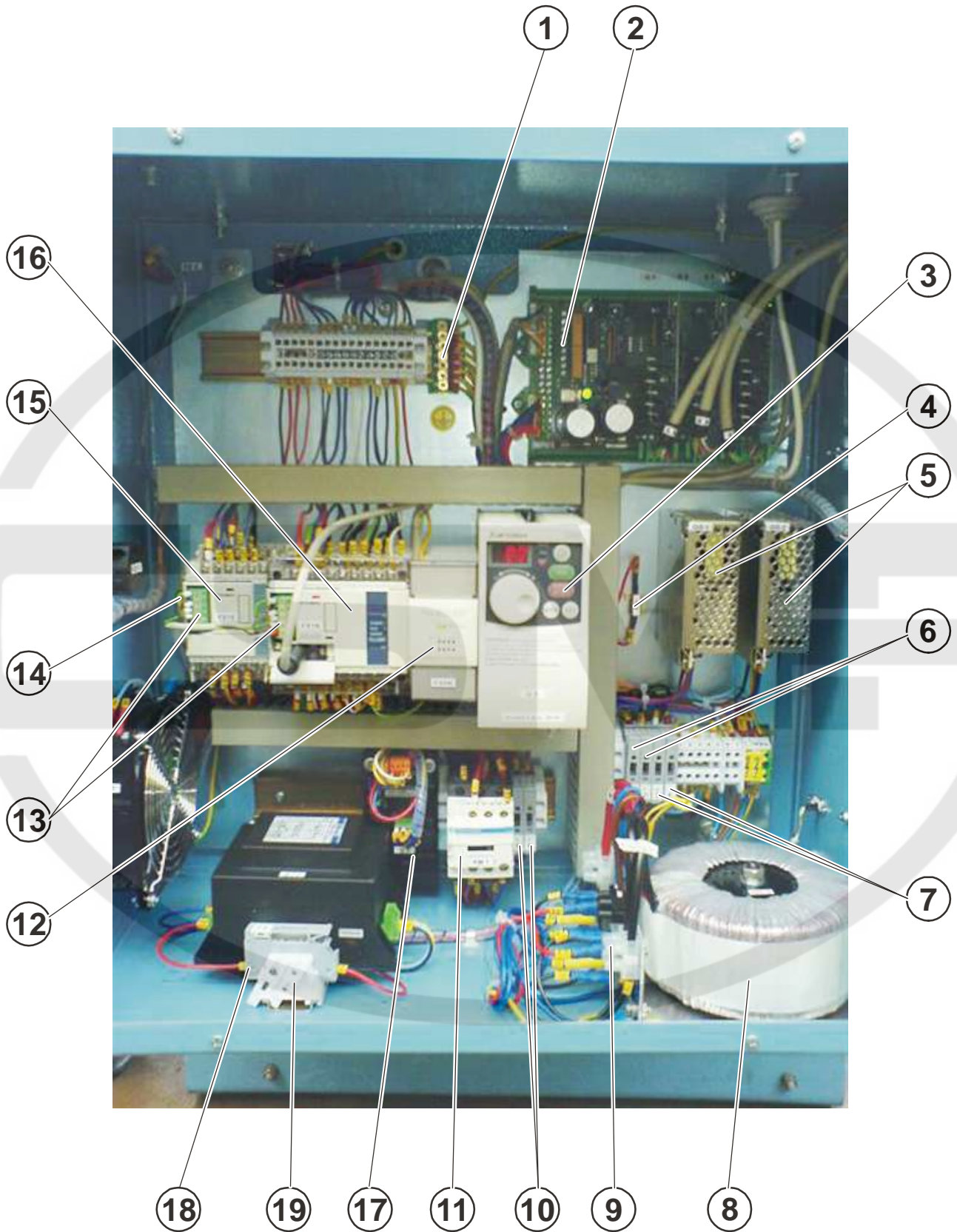

ELECTRONIC BOX-ELECTRONIC PARTS -III

DET	PART NUMBER	DESCRIPTION	QTY.
01	12.0008.4.050	Bridge GND	1
02	12.0008.4.891	Driver MD-921	1
03	19.8001.1.006	Inverter	1
04	19.0007.9.482	Resistor	1
05	12.0008.4.709	Power Supply	2
06	12.0008.4.665	F1, F2 Fuse T2A	2
07	12.0008.4.664	F3, F4 Fuse T10A	2
08	12.0008.4.756	Toroid Trafo	1
09	12.0008.4.770	Rectifier	2
10	12.0008.4.664	F5, F6 Fuse T10A	2
11	12.0008.4.833	Contactora	1
12	12.0008.4.748	Ext. Block	1
13	12.0008.4.749	Communic. Block	2
14	12.0008.4.751	Filter	1
15	19.8001.1.103	PLC FX1S	1
16	19.8001.1.101	PLC FX1N	1
17	12.0008.4.898	Driver	1
18	12.0008.4.781	Power Supply	1
19	12.0008.4.109	F9 Fuse T5A	1

Revised 01/2007

e-mail: service@amfreece.cz; parts@amfreece.cz; website: www.amfreece.com

Phones: +420 582 309 146 (Service), +420 582 309 286 (Spare Parts); Fax: +420 582 360 606



INDEX

PART NUMBER	PAGE	DET	QTY	PART NUMBER	PAGE	DET	QTY	PART NUMBER	PAGE	DET	QTY
00.2751.3.602				08.6000.3.005	3-27	10	4	08.6000.4.020	3-9	04	1
00.2751.3.602	3-49	54	1	08.6000.3.005	3-49	38	(1)	08.6000.4.020	3-15	11	1
00.2751.3.602	3-51	22	1	08.6000.3.005	3-17 i	38	(1)	08.6000.4.020	3-27	05	1
00.2751.3.602	3-17 i	54	1	08.6000.3.006	3-41	15*	4	08.6000.4.025	3-41	05	4
00.2751.3.602	3-19 i	22	1	08.6000.3.006	3-41	31	(2)	08.6000.4.035	3-33	14	(2)
01.2056.1.000	3-57	09	1	08.6000.3.006	3-69	51	1	08.6000.5.012	3-21	09	3
01.2056.1.000	3-59	05	(1)	08.6000.3.006	3-75	15	1	08.6000.5.012	3-23	20	2
01.2056.1.000	3-69	04	(1)	08.6000.3.008	3-17	31	2	08.6000.5.012	3-25	03	2
01.2056.1.000	3-77	03	(1)	08.6000.3.008	3-41	37**	1	08.6000.5.012	3-27	38	2
01.4750.0.000	3-49	32	4	08.6000.3.008	3-47	28	4	08.6000.5.016	3-21	13	5
01.4750.0.000	3-17 i	32	4	08.6000.3.008	3-61	71	1	08.6000.5.016	3-23	23	1
01.5003.0.000	3-11	09	(2)	08.6000.3.008	3-67	22	(1)	08.6000.5.016	3-31	12	8
01.5619.0.000	3-17	17	1	08.6000.3.008	3-71	46	(2)	08.6000.5.020	3-23	19	1
01.5620.0.000	3-17	11	1	08.6000.3.010	3-67	21	(1)	08.6000.5.020	3-29	07	2
02.0558.0.111	3-11	17	1	08.6000.3.010	3-5 i	5	4	08.6000.5.020	3-5 i	16	3
02.0558.0.111	3-69	43	(5)	08.6000.3.014	3-75	37	1	08.6000.5.022	3-45	8	1
02.0558.1.112	3-61	58*	6	08.6000.3.025	3-3 i	1	2	08.6000.5.060	3-69	33	(1)
03.5519.0.003	3-49	48	1	08.6000.3.030	3-13	20	(2)	08.6000.6.010	3-47	13	2
03.5519.0.003	3-17 i	48	1	08.6000.3.030	3-67	05	(2)	08.6000.6.012	3-21	28	4
03.5519.1.090	3-49	01	1	08.6000.4.005	3-27	19	4	08.6000.6.030	3-29	45	(1)
03.5519.1.091	3-17 i	01	1	08.6000.4.005	3-29	37	4	08.6000.8.020	3-27	01	4
03.5519.3.002	3-81	1	1	08.6000.4.005	3-39	25	2	08.6010.2.004	3-67	35	(2)
03.5519.3.011	3-75	01	1	08.6000.4.005	3-41	39	2	08.6010.2.004	3-71	22	(2)
03.5519.3.013	3-67	01*	1	08.6000.4.005	3-81	4	(2)	08.6010.3.005	3-17	09	3
03.5519.3.013	3-69	03	(1)	08.6000.4.006	3-31	05	1	08.6010.3.006	3-59	25	(4)
03.5519.3.016	3-59	01	1	08.6000.4.008	3-31	02	2	08.6010.3.006	3-69	09	(3)
03.5519.3.020	3-59	01		08.6000.4.008	3-39	08	2	08.6010.4.006	3-7	18	2
03.5519.3.024	3-59	01		08.6000.4.008	3-47	02	2	08.6010.4.006	3-41	21	1
03.5519.3.028	3-59	01		08.6000.4.008	3-49	18	2	08.6010.4.006	3-75	9	1
03.5519.3.029	3-59	01		08.6000.4.008	3-75	2	1	08.6010.4.008	3-53	21	2
03.5519.3.030	3-69	01	1	08.6000.4.008	3-3 i	24	4	08.6010.4.008	3-3 i	23	4
03.5519.3.050	3-77	01	1	08.6000.4.008	3-5 i	22	2	08.6010.4.008	3-21 i	21	2
04.1416.0.003	3-49	02	1	08.6000.4.008	3-17 i	18	2	08.6010.4.010	3-27	09	1
04.1416.0.003	3-17 i	02	1	08.6000.4.010	3-13	19	(2)	08.6010.4.012	3-19	44	2
04.9000.0.444	3-29	38	1	08.6000.4.010	3-15	05	2	08.6010.4.012	3-33	15	(2)
04.9000.1.443	3-29	42	(1)	08.6000.4.010	3-19	01	4	08.6010.4.012	3-35	20	4
04.9000.2.123	3-49	08	1	08.6000.4.010	3-27	27	2	08.6010.4.012	3-65	49	4
04.9000.2.123	3-17 i	08	1	08.6000.4.010	3-29	01	4	08.6010.4.012	3-73	53	(4)
04.9001.0.001	3-29	43	(1)	08.6000.4.010	3-31	19	2	08.6010.4.012	3-75	36	2
04.9001.1.050	3-29	46	1	08.6000.4.010	3-39	04	3	08.6010.4.012	3-79	26	(2)
05.0043.1.000	3-13	02	1	08.6000.4.010	3-41	20	2	08.6010.4.012	3-9 i	20	4
05.0043.1.000	3-15	19	1	08.6000.4.012	3-31	24	6	08.6010.4.012	3-11 i	49	4
05.0043.1.000	3-27	37	1	08.6000.4.012	3-7 i	8	4	08.6010.4.012	3-15 i	49	4
05.1322.0.000	3-29	33	(1)	08.6000.4.014	3-31	21	4	08.6010.4.012	3-37	20	4
07.0000.0.024	3-33	22	(5)	08.6000.4.014	3-39	10	1	08.6010.5.012	3-33	11	(4)
07.0000.0.024	3-33	26	2	08.6000.4.014	3-67	15	(2)	08.6010.5.012	3-35	01	2
07.6600.0.006	3-45	4	(1)	08.6000.4.014	3-73	68	(1)	08.6010.5.012	3-63	06	2
				08.6000.4.016	3-29	21	(1)	08.6010.5.016	3-21	19	2
08.6000.3.005				08.6000.4.016	3-41	10	4				
08.6000.3.005	3-21	15	6	08.6000.4.016	3-75	17	1	08.6012.2.006			

Note: i...indexer

Revised 01/2007

e-mail: service@amfreece.cz; parts@amfreece.cz; website: www.amfreece.com

Phones: +420 582 309 146 (Service), +420 582 309 286 (Spare Parts); Fax: +420 582 360 606

INDEX

PART NUMBER	PAGE	DET	QTY	PART NUMBER	PAGE	DET	QTY	PART NUMBER	PAGE	DET	QTY
08.6012.2.006	3-71	37	(2)	08.6200.4.006	3-67	04	(2)	08.6400.4.006	3-37	04	2
08.6012.2.006	3-73	61	(2)	08.6200.4.006	3-67	08	(2)	08.6400.4.008	3-21	25	2
08.6012.3.003	3-3 i	7	4	08.6200.4.006	3-11 i	15	1	08.6400.4.010	3-11	34	3
08.6012.3.006	3-13	08	(2)	08.6200.4.006	3-15 i	15	1	08.6400.4.010	3-15	16	1
08.6012.3.006	3-71	25	(1)	08.6200.4.008	3-15	10	2	08.6400.4.010	3-77	22	(1)
08.6012.4.006	3-69	24	(2)	08.6200.4.008	3-27	13	3	08.6400.4.010	3-5 i	8	2
08.6012.4.010	3-11	02	3	08.6200.4.008	3-39	23	1	08.6400.4.030	3-25	01	1
08.6012.7.016	3-67	11	(2)	08.6200.4.008	3-41	23	4				
08.6032.3.008	3-9	01	1	08.6200.4.008	3-63	16	1	08.6400.5.005			
08.6032.4.008	3-13	01	1	08.6200.4.008	3-67	23	(2)	08.6400.5.005	3-3	07	2
08.6032.4.008	3-15	20	1	08.6200.4.012	3-17	29	1	08.6400.5.006	3-33	23	(1)
08.6032.4.008	3-39	20	6	08.6200.4.016	3-75	32	2	08.6400.5.008	3-19	36	2
08.6032.4.008	3-43	04	6	08.6200.5.006	3-29	14	1	08.6400.5.030	3-23	27	1
08.6032.4.008	3-7 i	01	5	08.6200.5.006	3-45	5	(1)	08.6400.5.305	3-19	16	2
08.6032.4.010	3-49	39	(4)	08.6200.5.012	3-29	24	2	08.6400.5.305	3-21	22	2
08.6032.4.010	3-17 i	39	(4)	08.6200.5.020	3-31	47	2	08.6400.6.006	3-3	21	(2)
08.6032.4.012	3-51	08	14	08.6200.6.010	3-49	45	(2)	08.6400.6.006	3-5	01	4+(2)
08.6032.4.012	3-19 i	08	14	08.6200.6.010	3-17 i	45	(2)	08.6400.6.006	3-19	07	(2)
08.6032.4.016	3-51	09	4	08.6310.4.030	3-33	19	(3)	08.6400.6.006	3-21	29	2
08.6032.4.016	3-19 i	09	4	08.6310.6.016	3-29	41	(2)	08.6400.6.006	3-31	22	6
08.6032.5.010	3-5 i	9	2	08.6312.8.020	3-53	12	(2)	08.6400.6.006	3-49	51	1
08.6050.5.006	3-3 i	27	4	08.6312.8.020	3-21 i	12	(2)	08.6400.6.006	3-71	02	(2)
08.6100.3.010	3-3 i	18	8	08.6312.8.040	3-49	31	8	08.6400.6.006	3-79	01	(1)
08.6100.4.006	3-75	21	2	08.6312.8.040	3-17 i	31	8	08.6400.6.006	3-9 i	1	2
08.6100.4.008	3-3 i	14	4	08.6400.3.004	3-17	08	1	08.6400.6.006	3-11 i	06	
08.6100.4.010	3-61	52	(1)	08.6400.3.005	3-11	32	(2)	08.6400.6.006	3-15 i	6	
08.6100.4.010	3-69	35	(1)	08.6400.3.005	3-39	22	1	08.6400.6.006	3-17 i	51	1
08.6100.4.012	3-53	15	(4)	08.6400.3.010	3-35	30	2	08.6400.6.006	3-37	01	2
08.6100.4.012	3-21 i	15	(4)	08.6400.3.010	3-63	04	2	08.6400.6.008	3-3	01	(2)
08.6100.5.010	3-5 i	7	1	08.6400.3.010	3-71	05	(2)	08.6490.4.009	3-75	39	1
08.6100.5.012	3-5 i	6	1	08.6400.3.010	3-9 i	30	2	08.6490.4.009	3-13 i	59	1
08.6100.5.020	3-31	03	1	08.6400.3.010	3-11 i	04	2	08.6490.4.009	3-15 i	59	1
08.6102.3.008	3-47	06	4	08.6400.3.010	3-15 i	4	2	08.6522.4.006	3-33	01	6
08.6117.3.004	3-71	21	(5)	08.6400.3.010	3-37	30	2	08.6522.4.006	3-5 i	1	3
08.6117.3.005	3-71	30	(4)	08.6400.4.004	3-31	43	(2)	08.6522.4.006	3-7 i	5	4
08.6132.4.010	3-71	10	(2)	08.6400.4.004	3-59	28	(2)	08.6532.8.050	3-49	21	8
08.6132.4.010	3-7 i	4	8	08.6400.4.004	3-69	11	(2)	08.6532.8.050	3-17 i	21	8
				08.6400.4.004	3-3 i	19	12	08.6532.8.070	3-49	55	4
08.6200.3.005				08.6400.4.005	3-13	10	(1)	08.6532.8.070	3-51	04	4
08.6200.3.005	3-35	32	2	08.6400.4.005	3-17	26	2	08.6532.8.070	3-17 i	55	4
08.6200.3.005	3-73	56	(2)	08.6400.4.006	3-35	04	2	08.6532.8.070	3-19 i	04	4
08.6200.3.005	3-79	25	(1)	08.6400.4.006	3-39	11	2	08.6632.3.016	3-49	06	15
08.6200.3.005	3-3 i	3	6	08.6400.4.006	3-45	13	1	08.6632.3.016	3-81	2	(4)
08.6200.3.005	3-5 i	18	4	08.6400.4.006	3-63	11	2	08.6632.3.016	3-17 i	06	15
08.6200.3.005	3-9 i	32	2	08.6400.4.006	3-71	12	(2)	08.6662.4.010	3-53	18	2
08.6200.3.005	3-11 i	39	2	08.6400.4.006	3-75	11	2	08.6662.4.010	3-21 i	18	2
08.6200.3.005	3-15 i	39	2	08.6400.4.006	3-79	04	(1)	08.6663.5.025	3-49	43	(1)
08.6200.3.005	3-37	32	2	08.6400.4.006	3-9 i	4	2	08.6663.5.025	3-17 i	43	(1)
08.6200.4.006	3-61	73	2	08.6400.4.006	3-11 i	11	2	08.6683.4.007	3-43	11	3
08.6200.4.006	3-63	15	1	08.6400.4.006	3-15 i	11	2				

Note: i...indexer

Revised 01/2007

e-mail: service@amfreece.cz; parts@amfreece.cz; website: www.amfreece.com

INDEX

PART NUMBER	PAGE	DET	QTY	PART NUMBER	PAGE	DET	QTY	PART NUMBER	PAGE	DET	QTY
08.6700.3.000				08.6710.4.000	3-37	12	4	08.6850.8.000	3-25	07	2
08.6700.3.000	3-9	15	1	08.6710.5.000	3-19	32	2	08.6850.8.000	3-29	48	2
08.6700.3.000	3-13	16	(1)	08.6710.5.000	3-59	08	(2)	08.6852.3.000	3-13	21	(1)
08.6700.3.000	3-17	30	2	08.6710.5.000	3-69	34	(1)	08.6852.3.000	3-3 i	8	4
08.6700.3.000	3-29	29	1					08.6852.4.000	3-43	03	4
08.6700.3.000	3-59	13	(2)	08.6710.8.400				08.6852.4.000	3-53	23	2
08.6700.3.000	3-67	18	(1)	08.6710.8.400	3-7	16	1	08.6852.4.000	3-61	70	1
08.6700.4.000	3-9	07	1	08.6710.8.400	3-23	07	2	08.6852.4.000	3-21 i	23	2
08.6700.4.000	3-25	02	1	08.6710.9.500	3-23	06	1	08.6852.8.000	3-49	25	12
08.6700.4.000	3-41	17	1	08.6722.8.000	3-49	28	2	08.6852.8.000	3-51	27	4
08.6700.4.000	3-79	13	(2)	08.6722.8.000	3-17 i	28	2	08.6852.8.000	3-53	13	(4)
08.6700.4.000	3-3 i	4	2	08.6733.8.000	3-49	53	4	08.6852.8.000	3-17 i	25	12
08.6700.5.000	3-17	22	1	08.6733.8.000	3-17 i	53	4	08.6852.8.000	3-19 i	27	4
08.6700.5.000	3-23	26	1	08.6800.5.000	3-5 i	15	3	08.6852.8.000	3-21 i	13	(4)
08.6700.5.000	3-5 i	12	1	08.6800.6.000	3-29	40	(2)	08.6887.5.000	3-75	14	1
08.6700.6.000	3-67	03	(2)	08.6800.8.000	3-27	34	4				
08.6700.6.300	3-31	15	2	08.6802.3.000	3-13	22	(1)	10.1010.3.000			
08.6702.2.000	3-71	31	(2)	08.6802.8.000	3-49	26	12	10.1010.3.000	3-13	18	(1)
08.6702.4.000	3-25	10	1	08.6802.8.000	3-53	16	(2)	10.1021.2.000	3-11	10	(2)
08.6702.4.000	3-51	17	12	08.6802.8.000	3-17 i	26	12	10.2552.3.006	3-77	23	(1)
08.6702.4.000	3-53	22	1	08.6802.8.000	3-21 i	16	(2)	10.2552.3.006	3-79	14	(1)
08.6702.4.000	3-19 i	17	12	08.6832.4.000	3-53	24	1	10.2559.1.010	3-79	11	(1)
08.6702.4.000	3-21 i	22	1	08.6832.4.000	3-21 i	24	1	10.2559.1.104	3-77	24	(1)
08.6702.6.000	3-51	25	2	08.6832.6.000	3-51	26	2	10.2566.0.000	3-79	08	(1)
08.6702.6.000	3-69	27	(1)	08.6832.6.000	3-19 i	26	2	10.2567.0.000	3-79	12	(1)
08.6702.6.000	3-19 i	25	2	08.6842.5.000	3-31	46	2	10.4010.2.000	3-17	10	1
08.6702.7.000	3-67	28	(2)	08.6850.3.000	3-27	39	2	10.4012.0.032	3-69	05	(1)
08.6702.8.000	3-49	27	14	08.6850.3.000	3-41	38**	1	10.4012.1.001	3-57	10	1
08.6702.8.000	3-51	28	4	08.6850.3.000	3-47	27	3	10.4012.2.014	3-59	06	(1)
08.6702.8.000	3-17 i	27	14	08.6850.3.000	3-59	04	(1)	10.4012.2.019	3-77	04	(1)
08.6702.8.000	3-19 i	28	4	08.6850.3.000	3-67	20	(3)				
08.6702.8.020	3-53	17	(2)	08.6850.3.000	3-69	19	(2)	12.0008.3.023			
08.6702.8.020	3-21 i	17	(2)	08.6850.4.000	3-15	06	2	12.0008.3.023	3-15	14	2
08.6710.3.000	3-35	31	2	08.6850.4.000	3-17	34	1	12.0008.3.023	3-41	04	13
08.6710.3.000	3-63	03	2	08.6850.4.000	3-27	26	2	12.0008.3.023	3-43	10	4
08.6710.3.000	3-67	17	(2)	08.6850.4.000	3-31	31	6	12.0008.3.023	3-45	19	2
08.6710.3.000	3-71	04	(2)	08.6850.4.000	3-33	16	(2)	12.0008.3.090	3-41	03	2
08.6710.3.000	3-9 i	31	2	08.6850.4.000	3-39	21	4	12.0008.3.409	3-3 i	30	2
08.6710.3.000	3-11 i	03	2	08.6850.4.000	3-41	19	2	12.0008.3.411	3-41	01	6
08.6710.3.000	3-15 i	3	2	08.6850.4.000	3-47	11	2	12.0008.3.411	3-45	15	1
08.6710.3.000	3-37	31	2	08.6850.4.000	3-75	3	1	12.0008.3.411	3-57	03	(3)
08.6710.4.000	3-27	17	1	08.6850.4.000	3-7 i	7	4	12.0008.3.411	3-61	56	((1))
08.6710.4.000	3-33	20	(2)	08.6850.5.000	3-19	33	2	12.0008.3.411	3-69	40	((2))
08.6710.4.000	3-35	12	4	08.6850.5.000	3-21	26	4	12.0008.3.412	3-41	34	1
08.6710.4.000	3-63	12	4	08.6850.5.000	3-23	11	1	12.0008.3.418	3-43	05	1
08.6710.4.000	3-71	14	(4)	08.6850.5.000	3-31	01	8	12.0008.3.420	3-43	32	1
08.6710.4.000	3-79	02	(2)	08.6850.5.000	3-5 i	11	5	12.0008.3.421	3-43	13	2
08.6710.4.000	3-9 i	12	4	08.6850.6.000	3-29	16	(3)	12.0008.3.421	3-45	12	2
08.6710.4.000	3-11 i	12	5	08.6850.6.000	3-29	44	(1)	12.0008.3.426	3-43	27	4
08.6710.4.000	3-15 i	12	5	08.6850.6.000	3-67	02	(1)	12.0008.3.426	3-57	14	(1)

Note: i...indexer

Revised 01/2007

e-mail: service@amfreece.cz; parts@amfreece.cz; website: www.amfreece.com

Phones: +420 582 309 146 (Service), +420 582 309 286 (Spare Parts); Fax: +420 582 360 606

INDEX

PART NUMBER	PAGE	DET	QTY	PART NUMBER	PAGE	DET	QTY	PART NUMBER	PAGE	DET	QTY
12.0008.3.426	3-61	49	(1)	12.0008.4.050				12.0008.4.751	3-55	14	1
12.0008.3.426	3-67	38	((1))	12.0008.4.050	3-55	01	1	12.0008.4.751	3-23 i	14	1
12.0008.3.427	3-43	18	2	12.0008.4.050	3-23 i	01	1	12.0008.4.756	3-55	08	1
12.0008.3.427	3-45	7	2	12.0008.4.058	3-43	09	4	12.0008.4.756	3-23 i	08	1
12.0008.3.428	3-45	11	1	12.0008.4.100	3-41	18	1	12.0008.4.757	3-49	49	1
12.0008.3.430	3-43	29	2	12.0008.4.109	3-23 i	19	1	12.0008.4.757	3-17 i	49	1
12.0008.3.447	3-45	22	1	12.0008.4.141	3-81	6	(1)	12.0008.4.758	3-53	05	1
12.0008.3.476	3-43	26	1	12.0008.4.197	3-41	13	1	12.0008.4.761	3-51	05	(2)
12.0008.3.477	3-43	21	24	12.0008.4.204	3-53	09	(1)	12.0008.4.761	3-19 i	05	(2)
12.0008.3.478	3-43	20	1	12.0008.4.204	3-21 i	09	(1)	12.0008.4.770	3-55	09	2
12.0008.3.479	3-43	23	1	12.0008.4.207	3-51	11	2	12.0008.4.770	3-23 i	09	2
12.0008.3.482	3-43	25	4+3	12.0008.4.207	3-19 i	11	2	12.0008.4.777	3-51	06	1
12.0008.3.482	3-57	05	(1)	12.0008.4.231	3-51	10	6	12.0008.4.777	3-19 i	06	1
12.0008.3.482	3-61	55	((1))	12.0008.4.231	3-51	29*	1*	12.0008.4.781	3-23 i	18	1
12.0008.3.482	3-67	37	((2))	12.0008.4.231	3-75	29	(1)	12.0008.4.821	3-49	46	(1)
12.0008.3.482	3-69	41	((1))	12.0008.4.231	3-19 i	10	6	12.0008.4.821	3-17 i	46	(1)
12.0008.3.483	3-43	22	1	12.0008.4.231	3-19 i	29*	1*	12.0008.4.833	3-55	11	1
12.0008.3.531	3-57	02	1	12.0008.4.280	3-61	48	(1)	12.0008.4.833	3-23 i	11	1
12.0008.3.531	3-69	02	(1)	12.0008.4.296	3-53	10	(1)	12.0008.4.885	3-53	03	1
12.0008.3.532	3-61	54	(1)	12.0008.4.296	3-21 i	10	(1)	12.0008.4.885	3-21 i	03	1
12.0008.3.534	3-69	38	(1)	12.0008.4.366	3-49	42	(1)	12.0008.4.891	3-55	02	1
12.0008.3.535	3-67	12	(1)	12.0008.4.366	3-17 i	42	(1)	12.0008.4.891	3-23 i	02	1
12.0008.3.622	3-69	39	((1))	12.0008.4.378	3-51	19	1	12.0008.4.898	3-75	27	(1)
12.0008.3.628	3-67	14	((2))	12.0008.4.378	3-19 i	19	1	12.0008.4.898	3-23 i	17	1
12.0008.3.629	3-67	26	((1))	12.0008.4.563	3-47	08	(1)				
12.0008.3.631	3-41	09	1	12.0008.4.570	3-15	17	1	12.0008.6.812			
12.0008.3.631	3-67	13	((1))	12.0008.4.613	3-51	12	1	12.0008.6.812	3-29	32	(1)
12.0008.3.649	3-61	57	((1))	12.0008.4.613	3-19 i	12	1	12.0008.6.901	3-49	07	1
12.0008.3.659	3-43	01	1	12.0008.4.615	3-51	13	(1)	12.0008.6.901	3-17 i	07	1
12.0008.3.689	3-45	21	1	12.0008.4.615	3-19 i	13	(1)	12.0008.6.915	3-39	17	3
12.0008.3.729	3-3 i	2	2	12.0008.4.664	3-55	7	2	12.0008.6.915	3-49	30	1
12.0008.3.733	3-41	26	2	12.0008.4.664	3-55	10	2	12.0008.6.915	3-17 i	30	1
12.0008.3.733	3-57	06	(1)	12.0008.4.664	3-23 i	07	2	12.0008.6.977	3-45	9	1
12.0008.3.734	3-41	07	2	12.0008.4.664	3-23 i	10	2	12.0008.6.980	3-45	18	1
12.0008.3.734	3-57	04	(2)	12.0008.4.665	3-55	06	2	12.0008.6.981	3-9 i	37*	
12.0008.3.739	3-41	27	2	12.0008.4.665	3-23 i	06	2	12.0008.6.981	3-13 i	62*	
12.0008.3.739	3-57	07	(1)	12.0008.4.682	3-51	23	(1)	12.0008.6.981	3-15 i	62*	
12.0008.3.741	3-41	29	2	12.0008.4.682	3-19 i	23	(1)	12.0010.4.011	3-5 i	10	2
12.0008.3.746	3-41	35	1	12.0008.4.691	3-51	18	(1)	12.0010.4.013	3-5 i	23	1
12.0008.3.753	3-43	02	1	12.0008.4.691	3-19 i	18	(1)	12.0010.4.025	3-47	14	(5)
12.0008.3.754	3-43	12	1	12.0008.4.709	3-55	05	2	12.0010.4.025	3-75	25	(1)
12.0008.3.754	3-45	2	1	12.0008.4.709	3-23 i	05	2	12.0010.4.038	3-5 i	4	2
12.0008.3.755	3-43	07	1	12.0008.4.710	3-53	04	5	12.1010.0.206	3-35	35	2
12.0008.3.756	3-43	06	2	12.0008.4.710	3-21 i	04	5	12.1010.0.206	3-73	55	(2)
12.0008.3.758	3-43	28	1	12.0008.4.716	3-51	20	1	12.1010.0.206	3-79	20	(1)
12.0008.3.759	3-43	17	1	12.0008.4.716	3-19 i	20	1	12.1010.0.206	3-9 i	35	2
12.0008.3.759	3-45	10	1	12.0008.4.748	3-55	12	1	12.1010.0.206	3-11 i	42	2
12.0008.3.760	3-43	19	1	12.0008.4.748	3-23 i	12	1	12.1010.0.206	3-15 i	42	2
12.0008.3.762	3-43	15	1	12.0008.4.749	3-55	13	2	12.1010.0.206	3-37	35	2
12.0008.3.764	3-41	16	1	12.0008.4.749	3-23 i	13	2	12.1010.0.306	3-47	31	2

Note: i...indexer

Revised 01/2007

e-mail: service@amfreece.cz; parts@amfreece.cz; website: www.amfreece.com

INDEX

PART NUMBER	PAGE	DET	QTY	PART NUMBER	PAGE	DET	QTY	PART NUMBER	PAGE	DET	QTY
12.1010.0.320	3-39	18	2	12.5050.2.014	3-31	16	1	17.0012.1.169	3-7	12	(1)
12.1010.0.408	3-63	44	1	12.8000.0.077	3-51	07	1	17.0012.2.400	3-17	23	1
12.1010.0.408	3-11 i	44	1	12.8000.0.077	3-19 i	07	1	17.0012.3.054	3-35	18	6
12.1010.0.408	3-15 i	44	1	12.8000.0.401	3-47	07	(1)	17.0012.3.054	3-63	23	4
12.1010.0.525	3-29	25	1	12.8000.0.423	3-51	21	1	17.0012.3.054	3-71	47	(4)
12.1010.0.530	3-41	25	2	12.8000.0.423	3-19 i	21	1	17.0012.3.054	3-9 i	18	6
12.1014.0.000	3-71	28	(1)	13.2087.1.000	3-27	06	1	17.0012.3.054	3-11 i	23	4
12.1040.1.001	3-11	39	(1)	14.1025.3.000	3-11	15	(2)	17.0012.3.054	3-15 i	23	4
12.1040.1.002	3-3	12	1	14.1028.4.000	3-11	30	(1)	17.0012.3.054	3-37	18	6
12.1040.1.002	3-21	16	3	14.1032.3.000	3-11	01	1	17.0012.4.070	3-21	04	2
12.1040.1.007	3-7	09	1					17.0012.4.070	3-31	44	1
12.1045.0.001	3-67	33	((2))	17.0003.6.156				17.0012.4.070	3-79	09	(2)
12.1045.0.004	3-17	48	1	17.0003.6.156	3-49	03	1	17.0012.4.103	3-63	32	2
12.1045.1.001	3-23	03	2	17.0003.6.156	3-17 i	03	1	17.0012.4.103	3-11 i	32	2
				17.0004.4.829	3-17	20	1	17.0012.4.103	3-15 i	32	2
12.2010.0.004				17.0004.9.893	3-77	06	(1)	17.0012.4.105	3-17	35	1
12.2010.0.004	3-29	18	(1)	17.0004.9.894	3-17	14	1	17.0012.4.106	3-17	41	1
12.2010.0.005	3-29	10	2	17.0004.9.895	3-17	07	1	17.0012.4.106	3-35	09	2
12.2010.0.011	3-3	11	1	17.0011.2.013	3-3	19	(2)	17.0012.4.106	3-63	17	2
12.2010.0.011	3-19	15	1	17.0011.2.063	3-23	16	1	17.0012.4.106	3-73	70	(2)
12.2010.0.011	3-21	17	2	17.0011.2.072	3-33	28	1	17.0012.4.106	3-11 i	17	2
12.2010.0.021	3-19	04	1	17.0012.0.077	3-71	19	(2)	17.0012.4.106	3-37	09	2
12.2010.0.023	3-3	14	2	17.0012.0.113	3-19	13	1	17.0012.6.400	3-79	10	(4)
12.2010.1.001	3-11	35	(1)	17.0012.0.120	3-11	23	(2)	17.0012.7.007	3-61	50	(1)
12.2050.0.004	3-5	15	(1)	17.0012.0.218	3-21	24	2				
12.2050.0.007	3-31	10	6	17.0012.0.290	3-5	03	1	17.0013.1.415			
12.2050.0.008	3-19	39	1	17.0012.0.303	3-35	21	2	17.0013.1.415	3-23	13	2
12.2050.1.005	3-65	56	1	17.0012.0.303	3-37	21	2	17.0013.1.415	3-75	41	1
12.2050.1.005	3-73	65	(1)	17.0012.0.350	3-79	17	(2)	17.0013.1.482	3-59	32	(1)
12.2050.1.005	3-13 i	56	1	17.0012.0.404	3-17	18	2	17.0013.1.485	3-79	15	(1)
12.2050.1.005	3-15 i	56	1	17.0012.0.543	3-11	24	(1)	17.0013.2.090	3-19	08	1
12.2050.1.007	3-21	07	1	17.0012.0.543	3-63	46	1	17.0013.4.027	3-23	18	1
12.2050.1.010	3-11	12	1	17.0012.0.543	3-11 i	46	1	17.0013.4.027	3-31	13	1
12.2070.0.004	3-31	29	4	17.0012.0.543	3-15 i	46	1	17.0013.5.067	3-35	05	2
12.2070.0.020	3-67	06	(1)	17.0012.0.571	3-23	15	2	17.0013.5.067	3-37	05	2
12.2080.0.002	3-9	11	((1))	17.0012.0.605	3-57	13	1	17.0013.5.067	3-63	10	2
12.2099.1.000	3-3 i	20	48	17.0012.0.605	3-63	47	1	17.0013.5.067	3-71	15	(2)
12.2099.1.009	3-21	06	1	17.0012.0.605	3-77	10	(1)	17.0013.5.067	3-9 i	5	2
12.3013.0.002	3-63	22	1	17.0012.0.605	3-11 i	47	1	17.0013.5.067	3-11 i	10	2
12.3013.0.002	3-11 i	22	1	17.0012.0.605	3-15 i	47	1	17.0013.5.067	3-15 i	10	2
12.3013.0.002	3-15 i	22	1	17.0012.0.688	3-59	10	(1)	17.0013.6.081	3-17	37	2
12.3015.7.016	3-75	34	4	17.0012.0.688	3-69	16	(1)	17.0013.6.081	3-59	22	(2)
12.5050.1.008	3-3	15	1	17.0012.1.137	3-59	30	(1)	17.0014.1.071	3-3	04	2
12.5050.1.501	3-49	56	1	17.0012.1.137	3-69	13	(1)	17.0014.1.119	3-33	27	2
12.5050.1.501	3-17 i	56	1	17.0012.1.140	3-17	04	2	17.0014.1.178	3-59	31	(1)
12.5050.2.005	3-31	17	1	17.0012.1.142	3-17	21	2	17.0015.3.022	3-9	13	1
12.5050.2.006	3-21	18	1	17.0012.1.142	3-65	58	1	17.0016.1.054	3-63	33	1
12.5050.2.008	3-3	05	1	17.0012.1.142	3-73	67	(1)	17.0016.1.054	3-11 i	33	1
12.5050.2.012	3-75	13	1	17.0012.1.142	3-13 i	58	1	17.0016.1.054	3-15 i	33	1
12.5050.2.013	3-21	10	1	17.0012.1.142	3-15 i	58	1	17.0016.1.094	3-19	37	(1)

Note: i...indexer

Revised 01/2007

e-mail: service@amfreece.cz; parts@amfreece.cz; website: www.amfreece.com

Phones: +420 582 309 146 (Service), +420 582 309 286 (Spare Parts); Fax: +420 582 360 606

INDEX

PART NUMBER	PAGE	DET	QTY	PART NUMBER	PAGE	DET	QTY	PART NUMBER	PAGE	DET	QTY
17.0016.1.190	3-7	01	1	17.0031.0.359	3-11	13	(1)	17.0087.0.204	3-77	09	(1)
17.0016.1.214	3-17	38	1	17.0031.0.406	3-19	10	(2)	17.0094.0.200	3-49	22	4
17.0016.1.298	3-75	23	1	17.0031.3.027	3-11	28	(1)	17.0094.0.200	3-17 i	22	4
17.0016.1.401	3-59	14	(1)	17.0033.1.109	3-7	05	1	17.0094.5.052	3-27	35	2
17.0017.1.059	3-17	46	1	17.0033.3.131	3-19	34	2	17.0095.1.272	3-49	33	12
17.0019.0.228	3-17	01	2	17.0041.1.094	3-17	03	4	17.0095.1.272	3-17 i	33	12
17.0019.0.228	3-33	31	2	17.0041.8.152	3-9	09	(1)	17.0095.1.329	3-15	07	1
17.0019.0.233	3-7	15	1	17.0042.1.279	3-29	49	1	17.0097.5.174	3-49	58	1
17.0019.0.398	3-19	28	1	17.0042.1.283	3-11	05	(1)	17.0097.5.174	3-17 i	58	1
17.0019.0.441	3-49	57	4	17.0042.6.082	3-77	17*	1	17.0097.5.182	3-49	34	1
17.0019.0.441	3-17 i	57	4	17.0042.6.083	3-77	18	(1)	17.0097.5.182	3-17 i	34	1
17.0019.0.517	3-7	14	3	17.0042.6.084	3-77	19	(1)				
17.0019.1.062	3-11	14	(2)	17.0042.6.085	3-77	20	(1)	18.0004.3.251			
17.0019.1.088	3-17	19	2	17.0042.6.086	3-77	14	(1)	18.0004.3.251	3-29	23	1
17.0019.2.066	3-35	07	2	17.0042.6.088	3-77	15	(1)	18.0011.2.400	3-11	21	(2)
17.0019.2.066	3-63	08	2	17.0042.6.090	3-77	16	(1)	18.0011.3.400	3-3	16	(1)
17.0019.2.066	3-71	07	(2)	17.0043.6.018	3-19	17	1	18.0026.4.403	3-59	24	(1)
17.0019.2.066	3-9 i	7	2	17.0043.6.018	3-21	21	1	18.0026.4.403	3-69	08	(1)
17.0019.2.066	3-11 i	08	2	17.0043.6.277	3-11	22	2	18.0028.3.401	3-59	36	(1)
17.0019.2.066	3-15 i	8	2	17.0043.6.351	3-11	27	1	18.0028.3.401	3-69	18	(1)
17.0019.2.066	3-37	07	2	17.0044.2.229	3-11	40	(1)	18.0031.0.481	3-59	38	(1)
17.0019.5.040	3-35	06	2	17.0064.7.162	3-17	28	1	18.0031.0.481	3-69	31	(1)
17.0019.5.040	3-63	09	2	17.0066.7.157	3-35	14	1	18.0032.3.198	3-29	20	(1)
17.0019.5.040	3-71	08	(2)	17.0066.7.157	3-37	14	1	18.0041.0.676	3-29	12	1
17.0021.1.069	3-31	08	2	17.0066.7.158	3-35	11	1	18.0052.0.274	3-29	19	(1)
17.0021.1.073	3-23	22	1	17.0066.7.158	3-37	11	1	18.0052.1.400	3-29	11	1
17.0026.0.215	3-17	25	2	17.0069.4.047	3-77	05	(1)	18.0061.3.350	3-29	22	(1)
17.0026.0.218	3-59	12	(1)	17.0069.4.048	3-17	15	1	18.0064.6.427	3-19	43	1
17.0026.1.084	3-3 i	9	2	17.0069.4.049	3-17	06	1	18.0066.7.410	3-9 i	11	1
17.0026.2.054	3-13	05	(1)	17.0074.4.405	3-19	42	1	18.0066.7.410	3-11 i	13	1
17.0026.2.054	3-59	21	(1)	17.0081.4.376	3-3	09	2	18.0066.7.411	3-9 i	14	1
17.0026.2.072	3-13	25	1	17.0081.5.047	3-7	17	2	18.0066.7.411	3-11 i	14	1
17.0026.2.400	3-17	45	1	17.0081.5.047	3-29	02	4	18.0081.1.403	3-15 i	52	1
17.0026.3.014	3-29	26	1	17.0081.5.082	3-17	32	1	18.0081.1.404	3-15 i	51	1
17.0026.3.173	3-17	42	1	17.0082.5.235	3-17	33	1	18.0081.8.706	3-17	12	1
17.0026.4.035	3-17	27	1	17.0082.5.884	3-35	27	1	18.0082.6.406	3-59	37	(1)
17.0026.4.064	3-63	29	1	17.0082.5.884	3-79	18	(1)	18.0082.6.406	3-69	20	(1)
17.0026.4.064	3-11 i	29	1	17.0082.5.884	3-37	27	1	19.0002.0.463	3-67	30	(1)
17.0026.4.064	3-15 i	29	1	17.0082.5.997	3-23	14	2	19.0002.1.403	3-11	08	1
17.0026.4.065	3-63	28	1	17.0082.6.000	3-41	14*	4	19.0002.4.402	3-11	04	1
17.0026.4.065	3-11 i	28	1	17.0082.6.402	3-59	20	(1)	19.0002.4.407	3-5	13	1
17.0026.4.065	3-15 i	28	1	17.0082.8.017	3-13	06	(2)	19.0002.5.409	3-27	08	1
17.0027.1.106	3-27	28	1	17.0082.8.082	3-59	39	(1)	19.0002.5.409	3-61	69	1
17.0027.1.419	3-15	15	1	17.0082.8.082	3-69	30	(1)	19.0002.5.411	3-27	36	2
17.0027.4.035	3-11	07	(1)	17.0082.8.083	3-17	44	2	19.0002.5.412	3-13	03	1
17.0027.4.045	3-19	31	1	17.0087.0.169	3-35	28	1	19.0002.8.104	3-9	06	1
17.0027.4.085	3-29	17	(1)	17.0087.0.169	3-79	19	(1)	19.0002.8.108	3-5	06	1
				17.0087.0.169	3-37	28	1	19.0003.1.600	3-35	36	1
17.0031.0.196				17.0087.0.204	3-57	12	1	19.0003.1.600	3-57	01	1
17.0031.0.196	3-29	27	1	17.0087.0.204	3-69	15	(1)	19.0003.1.601	3-9 i	36	1

Note: i...indexer

Revised 01/2007

e-mail: service@amfreece.cz; parts@amfreece.cz; website: www.amfreece.com

INDEX

PART NUMBER	PAGE	DET	QTY	PART NUMBER	PAGE	DET	QTY	PART NUMBER	PAGE	DET	QTY
19.0003.1.602	3-37	36	1	19.0006.9.448	3-17 i	20	1	19.0011.1.401	3-11	16	(1)
19.0003.1.655	3-69	37	(1)	19.0007.9.008	3-51	16	1	19.0011.1.402	3-7	08	1
19.0003.1.657	3-77	07	(1)	19.0007.9.008	3-19 i	16	1	19.0011.2.402	3-59	07	(1)
19.0003.1.657	3-79	27	1	19.0007.9.011	3-51	30*	1*	19.0011.2.403	3-3 i	5	2
19.0003.1.661	3-61	43		19.0007.9.011	3-75	28	(1)	19.0011.8.403	3-5	08	1
19.0003.1.661	3-63	01		19.0007.9.011	3-19 i	30*	1*	19.0011.8.404	3-13	07	(1)
19.0003.1.662	3-61	43		19.0007.9.018	3-53	06	1	19.0011.8.405	3-17	43	1
19.0003.1.662	3-63	01		19.0007.9.018	3-21 i	06	1	19.0011.8.406	3-13	07*	1
19.0003.1.663	3-61	43		19.0007.9.019	3-53	07	1	19.0012.0.689	3-59	34	(1)
19.0003.1.663	3-63	01		19.0007.9.019	3-21 i	07	1	19.0012.0.691	3-7	04	1
19.0003.1.664	3-63	01		19.0007.9.021	3-51	32	1	19.0012.1.404	3-65	55	1
19.0003.1.665	3-71	01	1	19.0007.9.021	3-19 i	32	1	19.0012.1.404	3-13 i	55	1
19.0003.1.671	3-11 i	01		19.0007.9.022	3-51	33	1	19.0012.1.404	3-15 i	55	1
19.0003.1.681	3-11 i	01		19.0007.9.022	3-19 i	33	1	19.0012.2.401	3-31	36	1
19.0003.1.682	3-15 i	1		19.0007.9.023	3-51	15	1	19.0012.5.400	3-59	42	(2)
19.0004.1.402	3-71	29	(1)	19.0007.9.023	3-19 i	15	1	19.0012.5.400	3-69	23	(2)
				19.0007.9.025	3-75	24	1	19.0013.0.001	3-57	08	1
19.0005.0.011				19.0007.9.027	3-5 i	13	1	19.0013.0.001	3-69	06	(1)
19.0005.0.011	3-49	37	(1)	19.0007.9.028	3-21 i	05	1	19.0013.0.001	3-77	02	(1)
19.0005.0.011	3-17 i	37	(1)	19.0007.9.029	3-21 i	25	1	19.0013.1.487	3-33	07	(4)
19.0005.0.012	3-49	36	(4)	19.0007.9.030	3-47	17	(1)	19.0013.1.491	3-59	15	(1)
19.0005.0.012	3-17 i	36	(4)	19.0007.9.031	3-47	19	(1)	19.0013.1.492	3-59	17	(1)
19.0005.0.013	3-49	44	(1)	19.0007.9.032	3-47	21	(1)	19.0013.1.496	3-75	31	1
19.0005.0.013	3-17 i	44	(1)	19.0007.9.036	3-53	11	(1)	19.0013.1.498	3-63	26	1
19.0005.0.014	3-51	31	1	19.0007.9.036	3-21 i	11	(1)	19.0013.1.498	3-11 i	26	1
19.0005.0.014	3-19 i	31	1	19.0007.9.037	3-53	08	1	19.0013.1.498	3-15 i	26	1
19.0005.0.015	3-49	24	1	19.0007.9.037	3-21 i	08	1	19.0013.6.400	3-19	19	2
19.0005.0.015	3-17 i	24	1	19.0007.9.038	3-81	5	(1)	19.0014.3.404	3-9	02	1
19.0005.0.016	3-49	23	1	19.0007.9.041	3-19 i	35	1	19.0014.3.405	3-41	30	2
19.0005.0.016	3-17 i	23	1	19.0007.9.472	3-75	26	(1)	19.0014.6.408	3-53	20	1
19.0005.0.019	3-5 i	3	1	19.0007.9.477	3-49	47	(1)	19.0014.6.408	3-21 i	20	1
19.0005.0.020	3-5 i	2	1	19.0007.9.477	3-17 i	47	(1)	19.0015.6.401	3-31	33	2
19.0005.0.021	3-3 i	31	1	19.0007.9.482	3-55	04	1				
19.0005.0.022	3-3 i	6	1	19.0007.9.482	3-23 i	04	1	19.0016.1.402			
19.0005.0.023	3-7 i	10	1	19.0007.9.483	3-43	16	1	19.0016.1.402	3-33	10	(2)
19.0005.0.024	3-7 i	9	1	19.0007.9.483	3-67	29	(1)	19.0016.1.402	3-35	16	2
19.0005.0.028	3-49	19	1	19.0007.9.498	3-47	29	3	19.0016.1.402	3-65	50	2
19.0005.0.028	3-17 i	19	1	19.0007.9.499	3-47	18	(1)	19.0016.1.402	3-71	49	(2)
19.0005.2.209	3-59	16	(1)	19.0007.9.518	3-75	30	(1)	19.0016.1.403	3-59	19	(1)
19.0005.2.210	3-59	23	(1)					19.0016.3.403	3-19	18	2
19.0005.2.210	3-69	07	(1)	19.0008.2.001				19.0016.3.403	3-31	32	2
19.0005.2.212	3-63	43	1	19.0008.2.001	3-29	35	1	19.0016.3.405	3-31	35	1
19.0005.2.212	3-11 i	43	1	19.0008.3.410	3-67	27	((1))	19.0016.3.407	3-75	18	1
19.0005.2.212	3-15 i	43	1	19.0008.3.412	3-41	28	1	19.0016.3.408	3-69	26	(1)
19.0005.2.214	3-17	36	1	19.0008.3.414	3-41	33	(1)	19.0017.2.402	3-29	28	1
19.0005.2.215	3-71	24	(1)	19.0008.3.415	3-45	3	(1)	19.0017.2.403	3-13	04	(1)
19.0005.2.216	3-59	27	(1)	19.0008.3.416	3-43	08	1	19.0017.2.404	3-13	24	(1)
19.0005.2.218	3-45	14	1	19.0011.0.400	3-17	39	1	19.0017.4.400	3-23	08	2
19.0005.2.219	3-69	10	(1)	19.0011.0.402	3-25	09	1	19.0019.0.682	3-21	14	3
19.0006.9.448	3-49	20	1	19.0011.1.400	3-61	51	(1)	19.0019.0.685	3-31	06	1

Note: i...indexer

Revised 01/2007

e-mail: service@amfreece.cz; parts@amfreece.cz; website: www.amfreece.com

Phones: +420 582 309 146 (Service), +420 582 309 286 (Spare Parts); Fax: +420 582 360 606

INDEX

PART NUMBER	PAGE	DET	QTY	PART NUMBER	PAGE	DET	QTY	PART NUMBER	PAGE	DET	QTY
19.0019.0.686	3-19	27	1	19.0032.8.401	3-15 i	21	2	19.0041.0.684	3-9 i	34	2
19.0019.0.687	3-11	31	(1)	19.0032.8.405	3-23	09	2	19.0041.0.684	3-11 i	37	2
19.0019.0.692	3-73	63	(1)	19.0033.1.401	3-35	24	2	19.0041.0.684	3-15 i	37	2
19.0019.0.693	3-5	12	1	19.0033.1.401	3-65	48	2	19.0041.0.684	3-37	34	2
19.0019.6.405	3-21	31	2	19.0033.1.401	3-73	52	(2)	19.0041.0.689	3-3	10	1
19.0026.3.400	3-9	05	1	19.0033.1.404	3-9 i	24	2	19.0041.0.690	3-41	08	2
19.0026.4.402	3-73	62	(1)	19.0033.1.404	3-11 i	48	2	19.0041.0.692	3-11	26	1
19.0026.4.404	3-67	32	(1)	19.0033.1.404	3-15 i	48	2	19.0041.0.693	3-19	21	(4)
19.0027.1.603	3-29	30	1	19.0033.1.404	3-37	24	2	19.0041.0.694	3-29	08	1
19.0027.1.610	3-35	33	2	19.0033.1.405	3-17	47	1	19.0041.1.400	3-65	57	1
19.0027.1.610	3-63	35	2	19.0033.1.406	3-33	05	(2)	19.0041.1.400	3-73	66	(1)
19.0027.1.610	3-73	59	(2)	19.0033.2.401	3-9	08	(2)	19.0041.1.400	3-13 i	57	1
19.0027.1.610	3-79	24	(1)	19.0033.2.403	3-75	19	4	19.0041.1.400	3-15 i	57	1
19.0027.1.610	3-9 i	33	2	19.0033.2.405	3-33	06	(2)	19.0041.2.404	3-19	30	1
19.0027.1.610	3-11 i	35	2	19.0033.2.408	3-13	15	(1)	19.0041.6.400	3-29	04	2
19.0027.1.610	3-15 i	35	2	19.0033.2.411	3-41	12	1	19.0041.6.401	3-11	11	(1)
19.0027.1.610	3-37	33	2	19.0033.3.401	3-19	25	(1)	19.0041.6.402	3-5	02	1
19.0027.1.615	3-17	24	1	19.0033.3.402	3-75	8	1	19.0041.8.401	3-19	12	2
19.0028.3.403	3-59	40	(1)	19.0033.3.405	3-67	25	(1)	19.0042.1.406	3-19	38	1
19.0028.3.403	3-69	21	(1)	19.0033.5.403	3-31	09	1	19.0042.1.408	3-5	09	(1)
19.0028.3.404	3-59	41	(1)	19.0033.5.404	3-17	40	1	19.0042.2.400	3-19	09	1
19.0028.3.404	3-69	22	(1)	19.0033.8.401	3-21	02	2	19.0042.5.401	3-21	08	1
19.0028.3.405	3-71	43	(1)	19.0033.8.401	3-31	41	1	19.0042.5.409	3-73	60	(1)
19.0028.3.406	3-71	44	(1)	19.0033.8.403	3-9	03	1	19.0043.6.046	3-31	39	1
19.0028.3.407	3-71	35	(1)	19.0033.8.405	3-5	18	1	19.0043.6.441	3-19	29	1
19.0031.1.400				19.0033.8.406	3-11	33	3	19.0043.6.442	3-5	17	1
19.0031.1.400	3-23	25	1	19.0033.8.407	3-17	05	1	19.0044.1.623	3-15	18	1
19.0031.3.404	3-71	40	(1)	19.0033.8.408	3-17	13	1	19.0044.1.623	3-27	16	3
19.0031.3.405	3-39	07	2	19.0034.0.401				19.0044.1.624	3-3	18	1
19.0031.3.407	3-19	45	(2)	19.0034.0.401	3-31	26	1	19.0044.1.625	3-3	20	1
19.0031.4.401	3-45	23*	(1)	19.0034.0.402	3-31	30	1	19.0044.1.626	3-65	54	1
19.0031.8.405	3-33	18	(3)	19.0034.0.403	3-31	25	2	19.0044.1.626	3-13 i	54	1
19.0031.8.412	3-67	36	((1))	19.0034.0.404	3-33	25	1	19.0044.1.626	3-15 i	54	1
19.0031.8.414	3-27	07	2	19.0034.0.409	3-19	11	1	19.0044.5.401	3-19	02	1
19.0031.8.416	3-5	04	1	19.0034.1.401	3-21	05	1	19.0044.5.402	3-21	23	1
19.0032.0.403	3-3 i	12	2	19.0034.2.402	3-25	05	1	19.0044.5.403	3-11	06	(1)
19.0032.2.405	3-59	18	(1)	19.0034.2.403	3-23	05	1	19.0044.5.404	3-29	34	(1)
19.0032.2.407	3-29	03	1	19.0034.6.402	3-19	40	1	19.0044.5.406	3-7	11	1
19.0032.3.401	3-29	09	1	19.0034.6.403	3-19	41	1	19.0045.3.400	3-11	36	1
19.0032.6.400	3-5	05	1	19.0034.7.400	3-23	12	1	19.0045.3.402	3-11	25	1
19.0032.6.401	3-19	35	2	19.0034.9.403	3-3	13	1	19.0051.0.409			
19.0032.6.404	3-67	16	(1)	19.0036.2.405	3-61	47	(1)	19.0051.0.409	3-3	17	1
19.0032.8.401	3-35	15	2	19.0041.0.675	3-31	11	3	19.0052.0.501	3-49	50	1
19.0032.8.401	3-37	15	2	19.0041.0.683	3-21	03	2	19.0052.0.501	3-17 i	50	1
19.0032.8.401	3-63	21	2	19.0041.0.683	3-31	40	1	19.0055.1.402	3-31	34	1
19.0032.8.401	3-71	11	(2)	19.0041.0.684	3-35	34	2	19.0055.1.403	3-31	38	1
19.0032.8.401	3-79	06	(1)	19.0041.0.684	3-63	37	2	19.0055.2.402	3-3	02	1
19.0032.8.401	3-9 i	15	2	19.0041.0.684	3-73	54	(2)	19.0055.4.403	3-11	29	(1)
19.0032.8.401	3-11 i	21	2	19.0041.0.684	3-79	22	(1)	19.0055.4.406	3-21	12	1

Note: i...indexer

Revised 01/2007

e-mail: service@amfreece.cz; parts@amfreece.cz; website: www.amfreece.com

INDEX

PART NUMBER	PAGE	DET	QTY	PART NUMBER	PAGE	DET	QTY	PART NUMBER	PAGE	DET	QTY
19.0055.4.407	3-21	11	2	19.0063.5.417	3-23	04	1	19.0064.7.405	3-33	17	(2)
19.0055.4.408	3-31	07	2	19.0063.5.418	3-71	03	(2)	19.0064.7.429	3-3 i	22	1
19.0055.4.418	3-75	12	2	19.0063.5.418	3-79	03	(1)	19.0064.7.430	3-75	38	1
19.0055.4.419	3-21	30	1	19.0063.5.418	3-9 i	2	2	19.0064.7.431	3-75	16	1
19.0055.4.421	3-3	06	1	19.0063.5.418	3-11 i	02	2	19.0064.7.432	3-31	18	1
19.0055.4.421	3-19	06	1	19.0063.5.418	3-15 i	2	2	19.0064.8.407	3-33	29	1
19.0055.4.422	3-5 i	17	1	19.0063.5.418	3-37	02	2	19.0064.8.409	3-33	04	(2)
19.0055.4.424	3-31	45	1	19.0063.6.441	3-33	13	(2)	19.0064.8.435	3-25	08	1
19.0055.4.425	3-31	27	1	19.0063.6.442	3-19	20	1	19.0064.8.438	3-67	07	(1)
19.0055.5.400	3-31	37	2	19.0063.6.443	3-19	24	1	19.0064.8.443	3-81	3	(1)
19.0058.1.400	3-31	28	2	19.0063.6.445	3-23	24	1	19.0064.8.444	3-41	24	4
19.0061.3.601	3-25	06	1	19.0063.6.447	3-75	5	1	19.0064.8.445	3-41	06	2
19.0061.3.601	3-33	12	(2)	19.0063.6.454	3-7	13	1	19.0064.8.446	3-75	35	1
19.0061.3.605	3-63	45	1	19.0063.6.456	3-23	17	1	19.0064.8.447	3-75	33	1
19.0061.3.605	3-11 i	45	1	19.0064.1.101	3-7	07	1	19.0064.8.448	3-31	14	1
19.0061.3.605	3-15 i	45	1	19.0064.5.849	3-61	43					
19.0061.3.610	3-25	04	1	19.0064.5.849	3-61	61		19.0066.7.412			
19.0061.3.611	3-73	64	(1)	19.0064.5.849	3-69	46	(1)	19.0066.7.412	3-15 i	13	1
19.0061.6.401	3-59	11	(1)	19.0064.5.850	3-61	62		19.0066.7.413	3-15 i	14	1
19.0062.2.407	3-75	7	1	19.0064.5.851	3-61	63		19.0066.7.422	3-71	17	(1)
19.0062.5.404	3-63	30	1	19.0064.5.852	3-61	64		19.0066.7.423	3-71	18	(1)
19.0062.5.404	3-11 i	30	1	19.0064.5.852	3-69	48	(1)	19.0066.7.424	3-11 i	13	1
19.0062.5.404	3-15 i	30	1	19.0064.5.853	3-61	65		19.0066.7.425	3-11 i	14	1
19.0062.5.405	3-59	35	(1)	19.0064.5.854	3-61	66		19.0066.8.400	3-35	08	1
19.0062.5.405	3-69	17	(1)	19.0064.5.854	3-69	49	(1)	19.0066.8.400	3-63	07	1
19.0062.5.408	3-35	23	2	19.0064.5.855	3-61	67		19.0066.8.401	3-35	03	1
19.0062.5.408	3-63	36	2	19.0064.5.856	3-61	68		19.0066.8.401	3-63	05	1
19.0062.5.408	3-73	58	(2)	19.0064.5.856	3-69	50	(1)	19.0066.8.402	3-71	41	(1)
19.0062.5.408	3-79	21	(1)	19.0064.5.952	3-69	47	(1)	19.0066.8.404	3-79	07	(1)
19.0062.5.408	3-9 i	23	2	19.0064.5.954	3-75	6	1	19.0066.8.405	3-71	06	(1)
19.0062.5.408	3-11 i	36	2	19.0064.5.973	3-77	12	(2)	19.0066.8.405	3-9 i	3	1
19.0062.5.408	3-15 i	36	2	19.0064.5.974	3-77	11	(1)	19.0066.8.405	3-11 i	05	1
19.0062.5.408	3-37	23	2	19.0064.6.472	3-61	53	(1)	19.0066.8.405	3-15 i	5	1
19.0062.6.402	3-33	30	(1)	19.0064.6.472	3-69	36	(1)	19.0066.8.405	3-37	03	1
19.0062.6.403	3-41	22	2	19.0064.6.493	3-77	21	(1)	19.0066.8.406	3-71	09	(1)
19.0062.7.410	3-31	04	1	19.0064.6.504	3-13	11	(1)	19.0066.8.406	3-9 i	8	1
				19.0064.6.506	3-3 i	15	1	19.0066.8.406	3-11 i	07	1
19.0063.0.402				19.0064.6.507	3-3 i	16	1	19.0066.8.406	3-15 i	7	1
19.0063.0.402	3-5	16	(1)	19.0064.6.508	3-3 i	13	2	19.0066.8.406	3-37	08	1
19.0063.1.073	3-17	02	1	19.0064.6.509	3-3 i	25	2	19.0067.1.025	3-7	03	1
19.0063.3.400	3-9	10	(1)	19.0064.6.510	3-3 i	21	1	19.0067.2.408	3-47	30	1
19.0063.3.402	3-11 i	40	1	19.0064.6.512	3-3 i	26	2	19.0067.2.415	3-3	08	1
19.0063.3.402	3-15 i	40	1	19.0064.7.402	3-35	13	2	19.0067.2.416	3-3	03	1
19.0063.3.403	3-29	15	1	19.0064.7.402	3-63	18	2	19.0067.4.401	3-19	14	1
19.0063.4.400	3-7	10	(1)	19.0064.7.402	3-71	13	(2)	19.0071.0.204	3-27	02	1
19.0063.4.403	3-7	02	1	19.0064.7.402	3-79	05	(1)	19.0071.3.403	3-15	04	1
19.0063.4.404	3-5	07	(1)	19.0064.7.402	3-9 i	13	2	19.0071.4.205	3-33	21	(1)
19.0063.5.406	3-35	02	2	19.0064.7.402	3-11 i	18	2	19.0071.4.206	3-3 i	32	1
19.0063.5.406	3-63	02	2	19.0064.7.402	3-15 i	18	2	19.0071.7.404	3-19	03	1
19.0063.5.416	3-23	01	1	19.0064.7.402	3-37	13	2	19.0072.4.404	3-29	31	1

Note: i...indexer

Revised 01/2007

e-mail: service@amfreece.cz; parts@amfreece.cz; website: www.amfreece.com

Phones: +420 582 309 146 (Service), +420 582 309 286 (Spare Parts); Fax: +420 582 360 606

INDEX

PART NUMBER	PAGE	DET	QTY	PART NUMBER	PAGE	DET	QTY	PART NUMBER	PAGE	DET	QTY
19.0074.0.000	3-5 i	14	1	19.0081.5.449	3-79	23	(1)	19.0082.3.453	3-27	20	1
19.0074.4.523	3-31	20	1	19.0081.5.449	3-9 i	25	2	19.0082.3.454	3-67	24	(1)
19.0074.4.527	3-23	21	1	19.0081.5.449	3-11 i	38	2	19.0082.3.455	3-75	4	1
19.0074.4.536	3-31	23	1	19.0081.5.449	3-15 i	38	2	19.0082.3.461	3-9	14	1
19.0074.4.537	3-77	13	(1)	19.0081.5.449	3-37	25	2	19.0082.3.462	3-5 i	20	1
19.0074.4.540	3-75	40	1	19.0081.5.451	3-71	34	(1)	19.0082.3.463	3-61	72	1
19.0074.4.541	3-7 i	6	2	19.0081.5.452	3-71	32	(1)	19.0082.3.757	3-43	14	1
19.0074.4.542	3-17	16	1	19.0081.5.453	3-71	42	(1)	19.0082.6.420	3-59	33	(1)
19.0074.6.215	3-63	19	1	19.0081.5.454	3-39	24	1	19.0082.6.421	3-35	17	1
19.0074.6.216	3-27	03	1	19.0081.5.459	3-13	12	(1)	19.0082.6.421	3-63	27	1
19.0074.6.221	3-11 i	19	1	19.0081.5.460	3-39	13	1	19.0082.6.421	3-73	72	(1)
19.0074.6.221	3-15 i	19	1	19.0081.5.461	3-21	27	1	19.0082.6.421	3-11 i	27	1
19.0074.6.225	3-39	01	1	19.0081.5.462	3-11 i	34	1	19.0082.6.421	3-37	17	1
19.0074.6.226	3-39	12	1	19.0081.5.464	3-15 i	34	1	19.0082.6.422	3-35	10	1
19.0074.6.227	3-39	05	1	19.0081.5.472	3-9 i	9	1	19.0082.6.422	3-73	71	(1)
19.0075.4.404	3-39	02	1	19.0081.5.472	3-13 i	60	1	19.0082.6.422	3-37	10	1
				19.0081.5.472	3-15 i	60	1	19.0082.6.426	3-71	38	(1)
19.0081.0.505				19.0081.5.473	3-9 i	6	1	19.0082.6.427	3-71	20	(1)
19.0081.0.505	3-33	09	(2)	19.0081.5.473	3-13 i	61	1	19.0082.6.432	3-71	36	(1)
19.0081.0.506	3-33	08	(2)	19.0081.5.473	3-15 i	61	1	19.0082.6.434	3-41	02**	3
19.0081.0.512	3-11 i	41	1	19.0081.5.474	3-5 i	21	1	19.0082.6.434	3-69	42	(2)
19.0081.0.512	3-15 i	41	1	19.0081.5.475	3-5 i	19	1	19.0082.6.445	3-3 i	28	1
19.0081.0.516	3-23	02	2	19.0081.6.402	3-47	03	1	19.0082.6.446	3-3 i	29	1
19.0081.1.760	3-35	19	1	19.0081.6.403	3-47	05	1	19.0082.6.448	3-3 i	11	2
19.0081.1.760	3-9 i	19	1					19.0082.6.450	3-3 i	10	1
19.0081.1.760	3-37	19	1	19.0082.1.405				19.0082.6.451	3-3 i	17	1
19.0081.1.761	3-35	22	1	19.0082.1.405	3-71	23	(1)				
19.0081.1.761	3-9 i	22	1	19.0082.1.406	3-11	38	(1)	19.0083.1.671			
19.0081.1.761	3-37	22	1	19.0082.1.409	3-13	23	(1)	19.0083.1.671	3-75	10	1
19.0081.1.766	3-13 i	51	1	19.0082.1.410	3-13	09	(1)	19.0083.1.681	3-27	14	1
19.0081.1.767	3-13 i	52	1	19.0082.2.526	3-59	29	(1)	19.0083.1.682	3-33	02	1
19.0081.1.770	3-71	50	(1)	19.0082.2.526	3-69	12	(1)	19.0083.1.683	3-33	03	1
19.0081.1.771	3-71	48	(1)	19.0082.2.531	3-13	13	(1)	19.0083.1.687	3-53	19	1
19.0081.4.445	3-75	20	1	19.0082.3.404	3-47	15	1	19.0083.1.687	3-21 i	19	1
19.0081.5.415	3-15	13	1	19.0082.3.407	3-15	09	1	19.0083.4.021	3-39	09	1
19.0081.5.418	3-47	26	1	19.0082.3.410	3-57	11	1	19.0083.7.002	3-49	40	(1)
19.0081.5.430	3-79	16	(1)	19.0082.3.410	3-69	14	(1)	19.0083.7.002	3-17 i	40	(1)
19.0081.5.433	3-35	29	1	19.0082.3.410	3-77	08	(1)	19.0084.1.613	3-19	46	(1)
19.0081.5.433	3-65	53	1	19.0082.3.411	3-27	11	1	19.0084.1.614	3-45	20	1
19.0081.5.433	3-9 i	29	1	19.0082.3.416	3-59	26	(1)	19.0087.0.420	3-59	09	(1+1*)
19.0081.5.433	3-37	29	1	19.0082.3.433	3-29	36	2	19.0087.0.424	3-71	27	(1)
19.0081.5.440	3-35	26	1	19.0082.3.434	3-69	28	(1)	19.0087.0.425	3-63	25	1
19.0081.5.440	3-9 i	26	1	19.0082.3.435	3-69	25	(1)	19.0087.0.425	3-11 i	25	1
19.0081.5.440	3-37	26	1	19.0082.3.437	3-71	45	(1)	19.0087.0.425	3-15 i	25	1
19.0081.5.447	3-73	51	(1)	19.0082.3.438	3-71	39	(1)	19.0087.0.428	3-63	20	1
19.0081.5.447	3-13 i	53	1	19.0082.3.439	3-71	16	(1)	19.0087.0.428	3-11 i	20	1
19.0081.5.447	3-15 i	53	1	19.0082.3.445	3-47	12	1	19.0087.0.428	3-15 i	20	1
19.0081.5.448	3-73	69	(1)	19.0082.3.447	3-67	19	(1)	19.0087.0.432	3-61	59	1
19.0081.5.449	3-35	25	2	19.0082.3.448	3-67	10	(1)	19.0087.0.432	3-69	44	(1)
19.0081.5.449	3-73	57	(2)	19.0082.3.450	3-27	25	1	19.0087.0.434	3-61	60*	1

Note: i...indexer

Revised 01/2007

e-mail: service@amfreece.cz; parts@amfreece.cz; website: www.amfreece.com

INDEX

PART NUMBER	PAGE	DET	QTY	PART NUMBER	PAGE	DET	QTY	PART NUMBER	PAGE	DET	QTY
19.0087.0.434	3-69	45	(1)	19.8001.0.006	3-55	03	1				
19.0091.0.402	3-49	04	1	19.8001.1.006	3-23 i	03	1				
19.0091.0.402	3-17 i	04	1	19.8001.1.101	3-23 i	16	1				
19.0094.0.404	3-47	04	1	19.8001.1.103	3-23 i	15	1				
19.0094.0.410	3-71	26	(1)	19.8001.1.105	3-17 i	35	(1)				
19.0094.0.414	3-39	14	1								
19.0094.1.400	3-29	05	2	23.2044.0.050							
19.0094.1.401	3-71	33	(1)	23.2044.0.050	3-13	17	(1)				
19.0094.2.408	3-67	09	(1)	24.0061.0.000	3-13	14	(1)				
19.0094.2.409	3-15	02	7	24.0097.0.000	3-53	14	(1)				
19.0094.2.409	3-27	23	5	24.0097.0.000	3-21 i	14	(1)				
19.0094.2.410	3-51	24	1	24.4019.0.000	3-49	41	(1)				
19.0094.2.410	3-19 i	24	1	24.4019.0.000	3-17 i	41	(1)				
19.0094.2.412	3-15	01	1								
19.0094.2.412	3-27	18									
19.0094.2.413	3-39	19	-								
19.0094.2.414	3-3 i	33	1								
19.0094.2.417	3-41	32	1								
19.0094.2.417	3-43	31	(1)								
19.0094.2.417	3-45	1	1								
19.0094.2.418	3-45	6	1								
19.0094.5.401	3-15	12	1								
19.0094.5.402	3-15	08	1								
19.0094.5.405	3-27	21	1								
19.0094.5.406	3-27	15	1								
19.0094.5.407	3-27	12	1								
19.0094.5.408	3-27	24	1								
19.0094.5.409	3-27	40	2								
19.0094.5.412	3-15	03	1								
19.0094.5.412	3-27	22									
19.0094.5.412	3-33	24	1								
19.0094.5.413	3-27	04	2								
19.0095.1.402											
19.0095.1.402	3-29	06	2								
19.0095.1.405	3-29	13	2								
19.0095.1.405	3-49	29	8								
19.0095.1.405	3-17 i	29	8								
19.0095.1.406	3-69	32	(1)								
19.0095.1.408	3-39	03	1								
19.0095.2.400	3-75	22	1								
19.0095.2.403	3-49	05	1								
19.0095.2.403	3-17 i	05	1								
19.0095.3.405	3-39	06	1								
19.0095.4.401	3-7 i	3	1								
19.0095.4.402	3-7 i	2	1								
19.0095.4.403	3-39	15	1								
19.8001.0.001	3-55	16	1								
19.8001.0.003	3-55	15	1								
19.8001.0.005	3-49	35	(1)								

Note: i...indexer

Revised 01/2007

e-mail: service@amfreece.cz; parts@amfreece.cz; website: www.amfreece.com

Phones: +420 582 309 146 (Service), +420 582 309 286 (Spare Parts); Fax: +420 582 360 606



Note: i...indexer