

PFAFF

1122

1122-G

Teileliste

Parts list

Lista de piezas

零件表

1122-720/02

1122-G-720/02

Diese Teileliste hat für Maschinen ab nachfolgender
Seriennummer Gültigkeit:

This parts list applies to machines from the following
serial numbers onwards:

Esta lista de piezas tiene validez para máquinas a partir del
número de serie siguiente:

本零件表对从下列系列号起的机器有效:

6001000 →

Alle Informationen und Abbildungen waren zum Zeitpunkt der Druckgebung auf dem neusten Stand.

Technische Änderungen vorbehalten!

Der Nachdruck, die Vervielfältigung sowie die Übersetzung - auch auszugsweise - aus PFAFF-Teilelisten ist nur mit unserer vorherigen Zustimmung und mit der Quellenangabe gestattet.

At the time of printing, all information and illustrations contained in this document were up to date.

Subject to alteration!

The reprinting, copying or translation of PFAFF Parts lists whether in whole or in part, is only permitted with our previous permission and with written reference to the source.

Todas las informaciones e ilustraciones de este manual estaban al día en el momento de entregarse para su impresión.

¡ Salvo modificaciones técnicas!

La reimpresión, reproducción y traducción - aunque sólo sea parcial - de las listas de piezas PFAFF sólo está permitida con nuestro permiso previo e indicando la fuente.

所有信息和图片在付印时都是最新的。

保留技术更改的权力!

全部或部分翻印、复制以及翻译PFAFF-零件表
必须事先经由我们同意并且注明来源。

PFAFF Industrie Maschinen AG

Postfach 3020

D-67653 Kaiserslautern

Königstr. 154

D-67655 Kaiserslautern

	Seite Page Página 页号
0 Wichtiger Hinweis	0 - 1
Important note	
Observación importante	
重要提示	
1 Vorwort	1 - 1
Foreword	
Notas preliminares	
前言	
2 Erläuterungen der Schlüsselzeichen	2 - 1
Explanation of key markings	
Explicaciones de los signos clave	
标记说明	
3 Basismaschine	
Basic machine	
Máquina básicas	
基础机器	
3.01 Gehäuseteile	3 - 1
Housing sections	
Piezas del cárter	
机身零件	
3.02 Kopfteile	3 - 2
Needle head parts	
Piezas de la cabeza	
机头零件	
3.03 Armteile	3 - 5
Arm parts	
Piezas del brazo	
机臂零件	
3.04 Grundplattenteile	3 - 10
Bedplate parts	
Piezas del cárter	
底板零件	

		Seite Page Página 页号
4	Nadelstangen-Schalteinrichtung (-720/02) Disengageable right and left needles (-720/02) Barra de aguja desconectable a izquierda (-720/02) 针杆开关装置 (-720/02)	4 - 1
5	Fadenabschneid-Einrichtung (-900/93) Thread trimmer (-900/93) Cortahilos (-900/93) 切线器 (-900/93)	5 - 1
6	Fadenabstreif-Einrichtung (-909/93) Thread wiper (-909/93) Retirahilos (-909/93) 拨线器 (-909/93)	6 - 1
7	Presserfuß-Automatik (-910/93) Automatic presser foot lifter (-910/93) Grupo acondicionador del aire comprimido (-910/93) 压脚自动提升器 (-910/93)	7 - 1
8	Verriegelungs-Einrichtung (-911/93) Backtacking mechanism (-911/93) Rematador (-911/93) 锁紧装置 (-911/93)	8 - 1
9	Elektrische Ausrüstung Electrical equipment Equipo eléctrico 电设备	
9.01	Bedienfeld Control panel Panel de mandos 操作板	2 - 1
9.02	Oberteilerkennung Sewing head identification Detección de la parte superior 机头识别	9 - 2

	Seite Page Página 页号
9.03 Positionsgeber Synchronizer Sincronizador 位置传感器	9 - 2
9.04 Einbaumotor Built-in motor Motor incorporado 内装式电机	9 - 3
9.05 Motor-Hauptschalter Main switch Interruptor principal 电机主开关	9 - 3
9.06 Sollwertgeber Set-point generator Emisor del valor teórico 给定值发生器	9 - 4
9.07 Steuerkasten Control box Caja de mandos 控制箱	9 - 5
10 Garnrollenständer Reel stands Portacarretes 线轴支架	10 - 1
11 Teile zur Tischplatte Parts for table top Piezas para el tablero 用于台板的零件	11 - 1
12 Keilriemen V-belt Correa trapezoidal 三角皮带	11 - 1

	Seite Page Página 页号
13 Knielüfterteile13 - 1 Knee lifter parts Piezas del alzaprensatelas por rodillera 膝松线器零件	
14 Schmiermittel-Übersicht14 - 1 Overview of lubricants Tabla de lubricantes 润滑剂一览	
15 Index (Teilenummern / Seitenzahlen)15 - 1 Index (part numbers / page numbers) Index (números de pieza / números de página) 注脚(零件号/页号)	
16 Unterklassen-Ausstattung Subclass parts Composición de las subclases 子机型-设备	
16.01 Nähwerkzeuge (PFAFF 1122).....16 - 2 Gauge parts (PFAFF 1122) Organos de costura (PFAFF 1122) 缝纫工具 (PFAFF 1122)	
16.02 Nähwerkzeuge (PFAFF 1122-G)16 - 4 Gauge parts (PFAFF 1122-G) Organos de costura (PFAFF 1122-G) 缝纫工具 (PFAFF 1122-G)	
16.03 Nähwerkzeuge (PFAFF 1122-720/02)16 - 6 Gauge parts (PFAFF 1122-720/02) Organos de costura (PFAFF 1122-720/02) 缝纫工具 (PFAFF 1122-720/02)	
16.04 Nähwerkzeuge (PFAFF 1122-G-720/02)16 - 8 Gauge parts (PFAFF 1122-G-720/02) Organos de costura (PFAFF 1122-G-720/02) 缝纫工具 (PFAFF 1122-G-720/02)	

Achtung!



Wir machen ausdrücklich darauf aufmerksam, daß Ersatz- und Zubehörteile, die nicht von uns geliefert werden, auch nicht von uns geprüft und freigegeben sind. Der Einbau und / oder die Verwendung solcher Produkte kann daher u. Umständen konstruktiv vorgegebene Eigenschaften Ihrer Maschine negativ verändern. Für Schäden, die durch die Verwendung von Nicht-Originalteilen entstehen, übernehmen wir keine Haftung!
Originalteile sind mit einem " P " oder der PFAFF-Teilenummer gekennzeichnet.

Caution!



We warn you expressively that spare parts and accessories that are not supplied by us are not tested and released by us. Fitting or using these products may therefore have negative influences on features that depend on the machine design. We are not liable for any damage caused by the use of non-Pfaff parts! Original parts are marked with a " P " or with the PFAFF part number.

¡Atención!



Se hace observar que en el caso de piezas de recambio y accesorios que no hayan sido suministrados por nosotros, quiere decir que non han sido sometidas por nuestra parte a un control y que no se les ha dado el visto bueno. Por esta razón, el montaje y/o empleo de tales productos puede repercutir negativamente en las características previstas en su máquina. ¡Para los daños que eventualmente pudiesen presentarse al utilizar piezas no originales, no asumimos ninguna garantía!
Las piezas originales se identifican con " P " o con el número de referencia de pieza de PFAFF.

注意!



我们必须明确指出，所有不是由我们供货的备件和附件都未经我们检查，也没有被我们批准使用。装入和/或使用这些产品可能在一定的情况下会对机器的设计特性造成负面改变。对由于使用非原装件所造成的损失，我们不负任何责任！
原装零件用字母 " P " 或者 PFAFF 零件号加标记。

- Die Seriennummer der Maschine, für die diese Teileliste Gültigkeit hat, ist auf der Titelseite aufgeführt.
 - Alle Teile sind so abgebildet, wie sie in der Maschine funktionsmäßig zusammengehören.
 - Gestrichelt dargestellte Teile zeigen angrenzende Teile aus anderen Funktionsgruppen.
 - Im oberen Teil der Bildseiten befindet sich eine Gesamtansicht der Maschine .
 - Der Einbauort der dargestellten Teile wird durch eine gerasterte Fläche gekennzeichnet.
 - Einrahmungen auf den Bildseiten zeigen, aus welchen Einzelteilen sich die Gruppenteile zusammensetzen.
 - Die auf den Bildseiten verwendeten Schlüsselzeichen (; 2 ; 3 usw.) sind im Kapitel "Erläuterungen der Schlüsselzeichen" aufgelistet.
-
- The serial number of the machine to which this parts list applies is indicated on the cover page.
 - All parts are illustrated in function groups with the parts which they function together with in the machine.
 - Parts illustrated with broken lines are parts from other function groups which border on the illustrated function group.
 - The above section of the page of illustrations contains a total view of the machine. The place for the installation of the parts pictured here is marked by the grid.
 - The framed-in sections on the illustration pages show the individual parts comprising a group.
 - The key markings used on the illustrated pages (; 2 ; 3 etc.) are listed in the chapter "Explanation of key markings".
-
- El número de serie de la máquina para la cual tiene validez esta lista de piezas va indicado en la página de título.
 - Todas las piezas están ilustradas tal como aparecen en la máquina para su funcionamiento.
 - Las piezas representadas con rayitas muestran piezas colindantes de otros grupos de funciones.
 - En la parte superior de las páginas ilustradas se puede ver una vista en conjunto de la máquina.
 - El lugar de montaje de la pieza representada va caracterizada mediante una superficie reticulada.
 - Los recuadros en las páginas ilustradas indican las piezas individuales de que se componen los grupos.
 - Los signos clave (; 2 ; 3 etc.) empleados en las páginas con ilustraciones van listados en el capítulo "Explicaciones de los signos clave".
-
- 适用于本零件表的机器系列号列在首页上。
 - 所有的零件都按照其在机器中的功能情况合在一起表达。
 - 用虚线表示的零件为相邻功能组中的零件。
 - 图的上部为机器全景。
 - 所示零件的安装部位用影格面表示。
 - 页上的框表示这套组件都由哪些零件所组成。
 - 图页上所使用的标记 (; 2 ; 3 等) 列表在“标记说明”中。

- Unterklassenabhängig, Teilenummer siehe Unterklassen-Ausstattung.**
Subclas-dependent, for part number see subclass parts listing.
Dependientes de la subclase, para el número de pieza véase "Dotación de subclases".
取决于子机型，零件号见子机型设备。
- A** **Maschinen-Ausstattung für feine Materialien.**
Model A for sewing thin and light-weight materials.
Tipo A para materiales ligeros.
用于薄料的机器设备。
- B** **Maschinen-Ausstattung für mittlere Materialien.**
Model B for sewing thin and medium-weight materials.
Tipo B para materiales semiligeros.
用于中厚料的机器设备。
- C** **Maschinen-Ausstattung für mittelschwere Materialien.**
Model C for sewing medium-heavy materials.
Tipo C para materiales semipesados.
用于中偏厚料的机器设备。
- 3** **Geklebt**
Part cemented
Pieza pegada
被粘住
- 6** **Nadeldicke und Spitzenform bei Bestellung angeben.**
Needle size and style of point to be stated on order.
Grosor de aguja y forma de la punta, indíquese en los pedidos.
在订货时给出针厚和针尖型式。
- 27/5** **Eingeklammerte Zahl = Länge in mm.**
Number in brackets = length in mm.
Cifra entre paréntesis = largura en mm.
被括起的数字=长度，单位mm。
- 28** **Sonderausführung**
Special version
Tipo especial
特殊款式
- 40/24** **Ölen mit 28-011 201-05; Bestellnummer siehe Seite 14 - 1.**
Oil with 28-011 201-05; for part number see page 14 - 1.
Lubrifique con grasa 28-011 201-05; para el número de pedido véase la página 14 - 1.
上油用 28-011 201-05; 订货号见 14 - 1页。

40/26

Füllen mit 28-011 201-05; Bestellnummer siehe Seite 14 - 1.
Top up with 28-011 201-05; for part number see page 14 - 1.
Rellene con 28-011 201-05; para el número de pedido véase la página 14 - 1.
注油用 28-011 201-05; 订货号见 14 - 1页。

40/27

Tränken mit 28-011 201-05; Bestellnummer siehe Seite 14 - 1.
Grease with 28-011 201-05; for part number see page 14 - 1.
Engrase con grasa 28-011 201-05; para el número de pedido véase la página 14 - 1.
浸油用 28-011 201-05; 订货号见 14 - 1

90/1

Für Wechselstrom
For single-phase A.C.
Para corriente alterna monofásica
适用于交流电



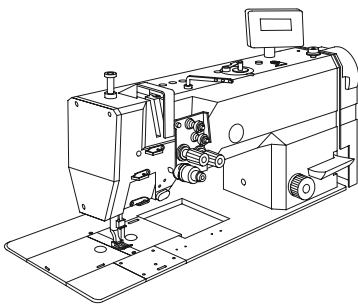

Gehäuseteile
Housing sections
Piezas del cárter
机身零件

PFAFF 1122
PFAFF 1122-G

3.01

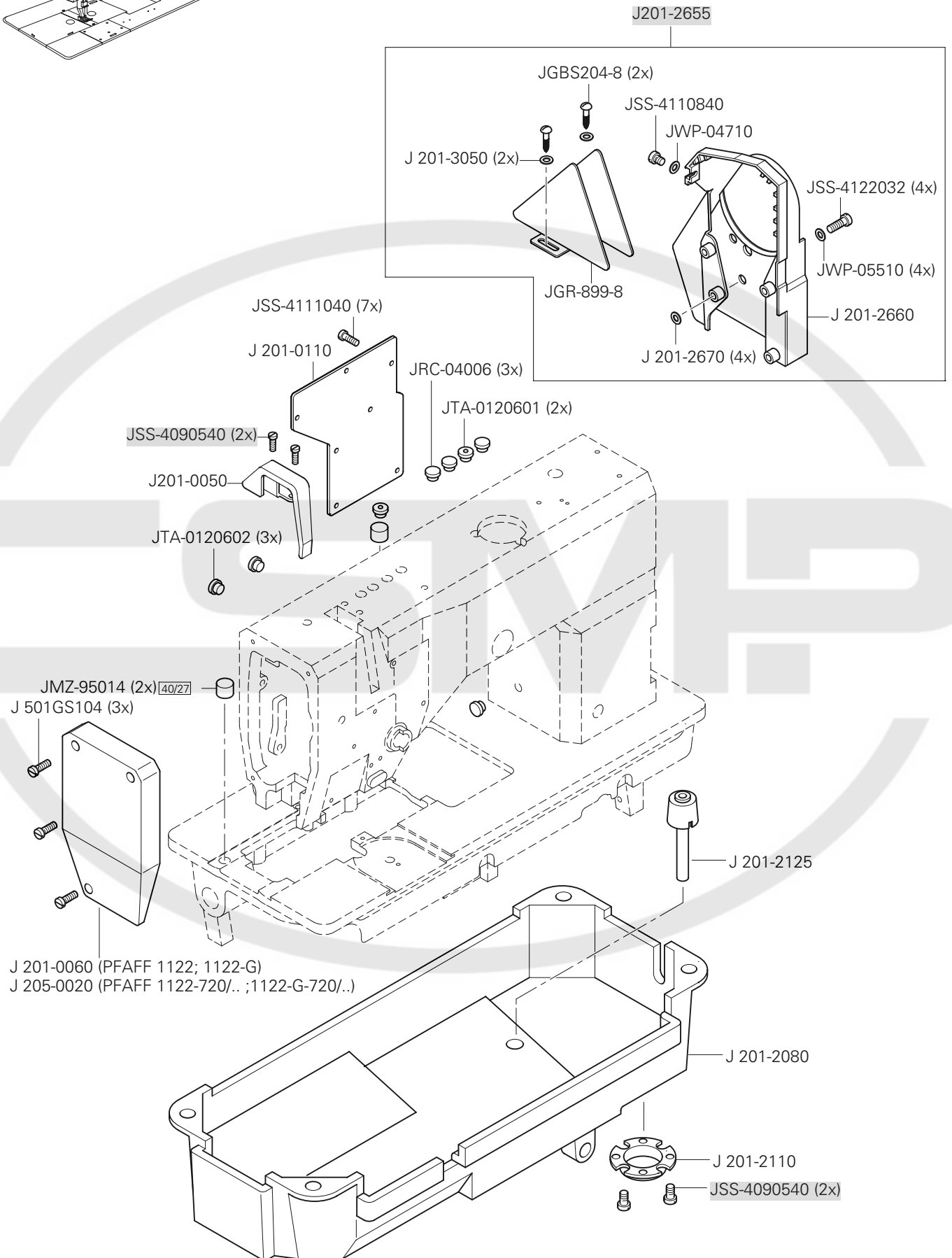

3.02

Kopfteile
Needle head parts
Piezas de la cabeza
机头零件

PFAFF 1122
PFAFF 1122-G

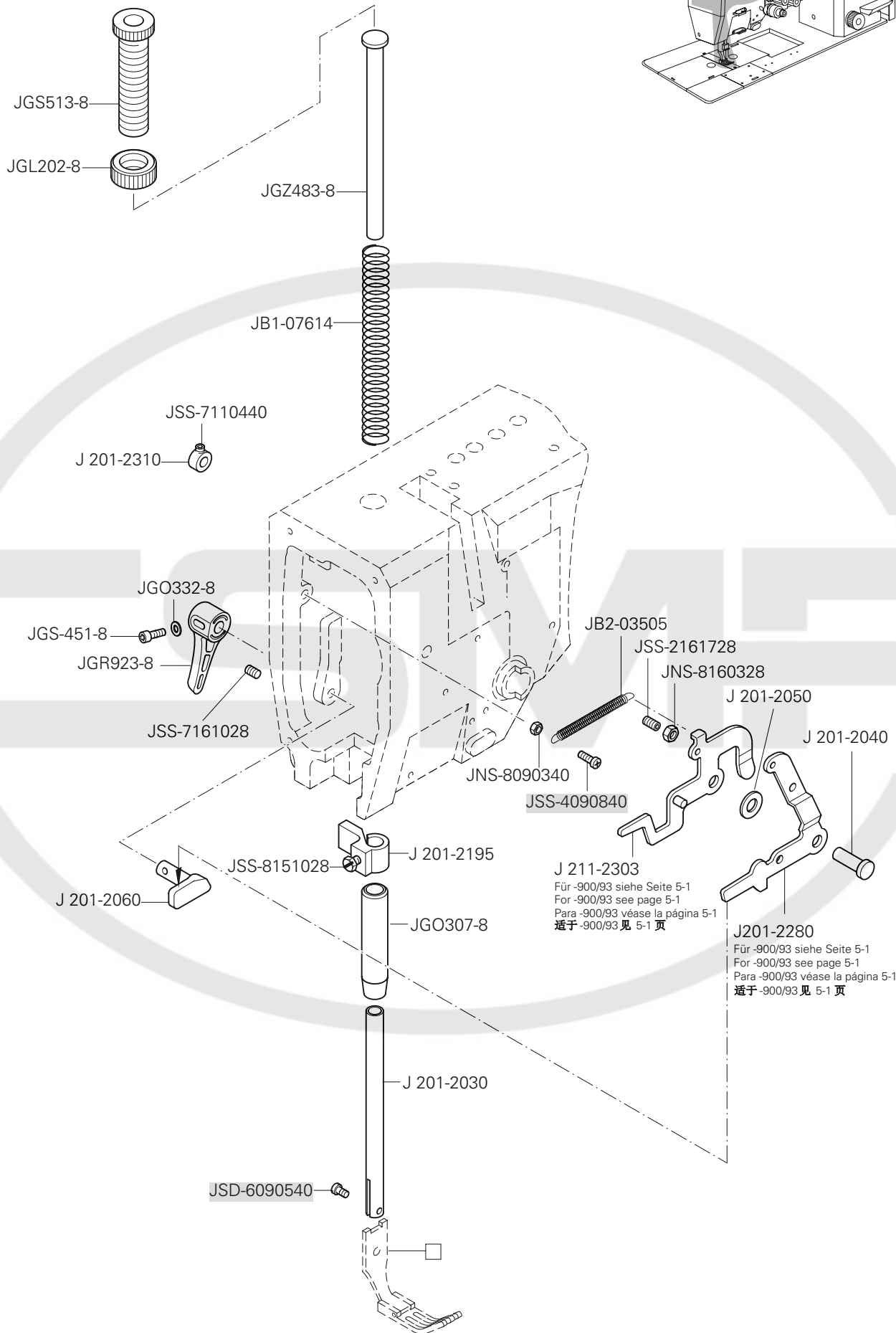
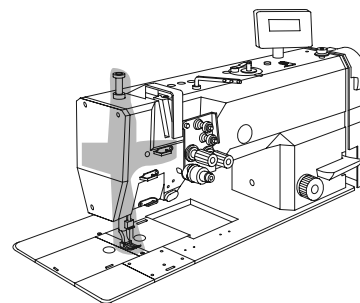

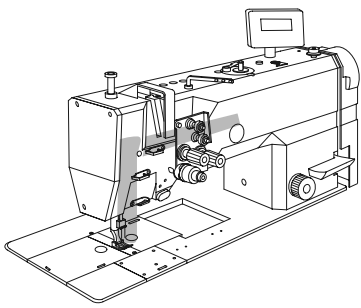

Kopfteile
Needle head parts
Piezas de la cabeza
机头零件

PFAFF 1122
PFAFF 1122-G

3.02

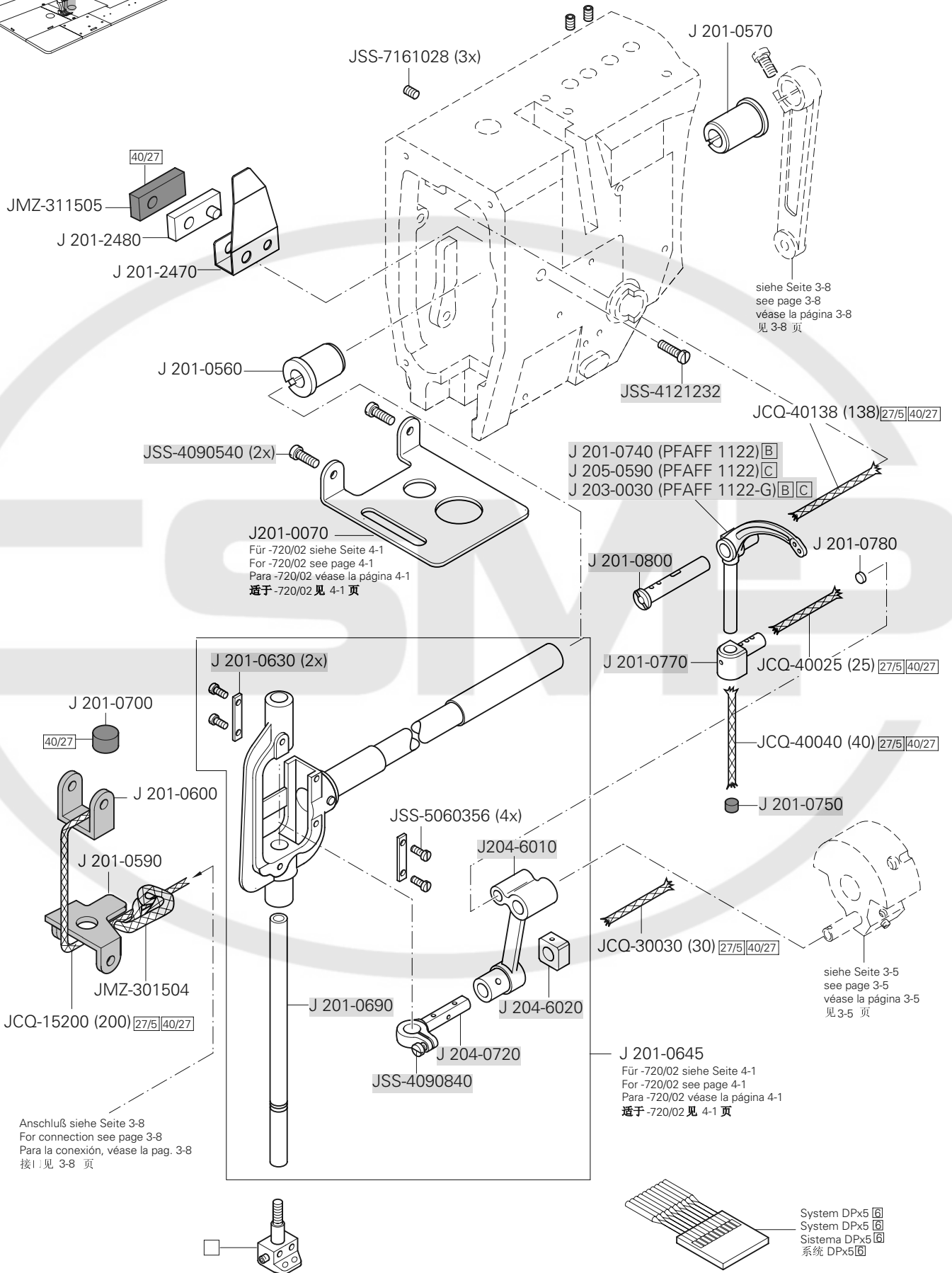

siehe Seite 3-8
see page 3-8
véase la página 3-8
见 3-8 页

siehe Seite 3-5
see page 3-5
véase la página 3-5
见 3-5 页

3.02

Kopfteile
Needle head parts
Piezas de la cabeza
机头零件

PFAFF 1122
PFAFF 1122-G

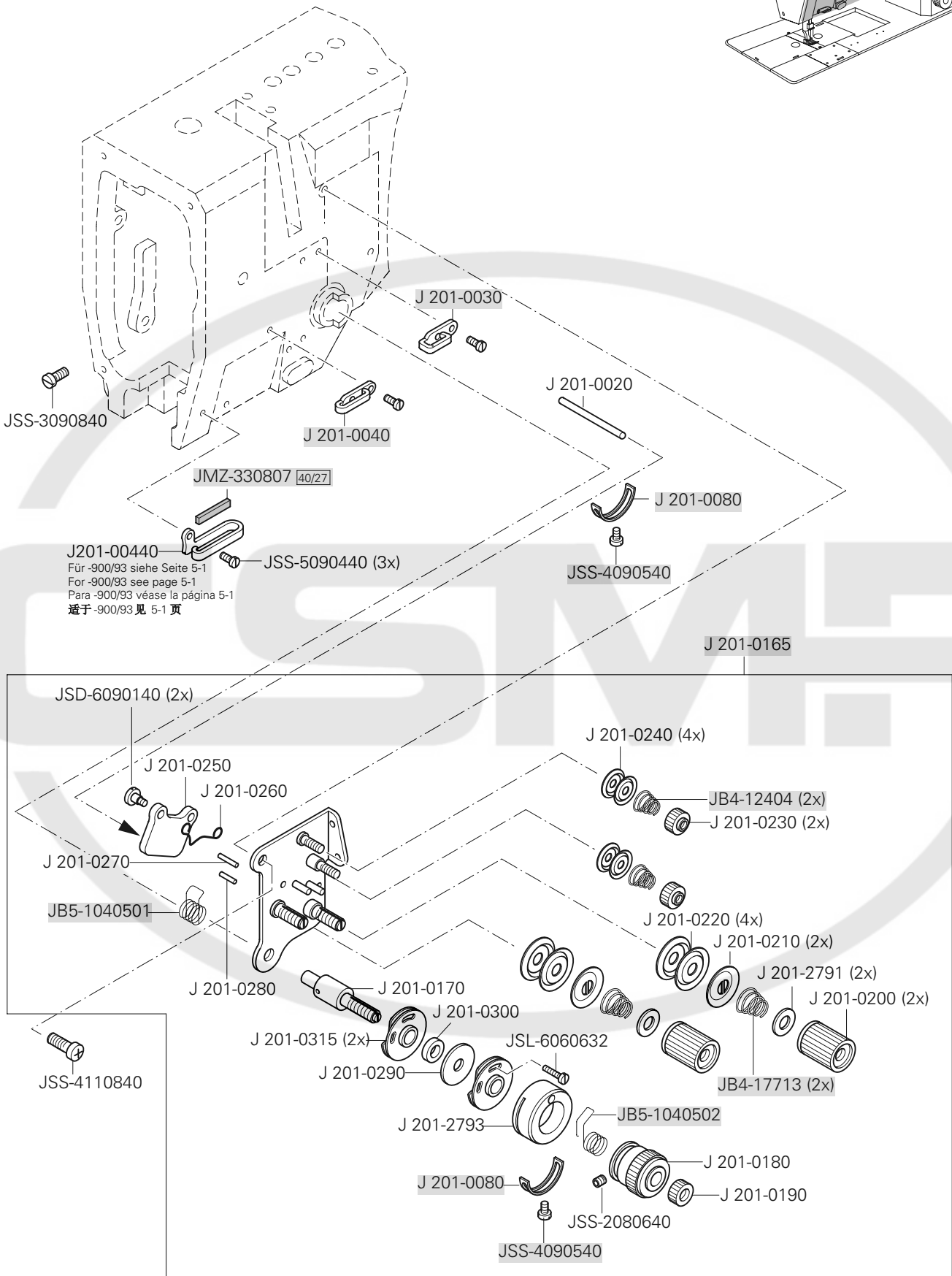
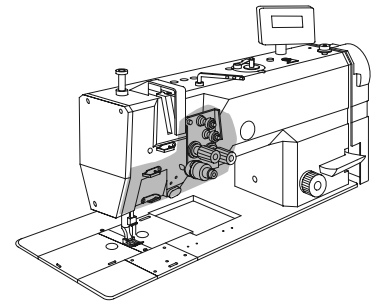

J201-00440
 Für -900/93 siehe Seite 5-1
 For -900/93 see page 5-1
 Para -900/93 véase la página 5-1
 适于-900/93 见 5-1 页

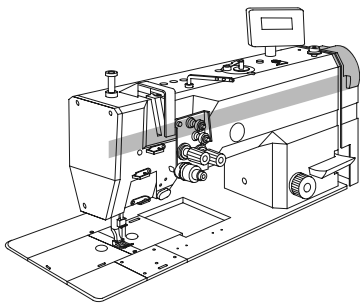

Armteile
 Arm parts
 Piezas del brazo
 机臂零件

PFAFF 1122
 PFAFF 1122-G

3.03

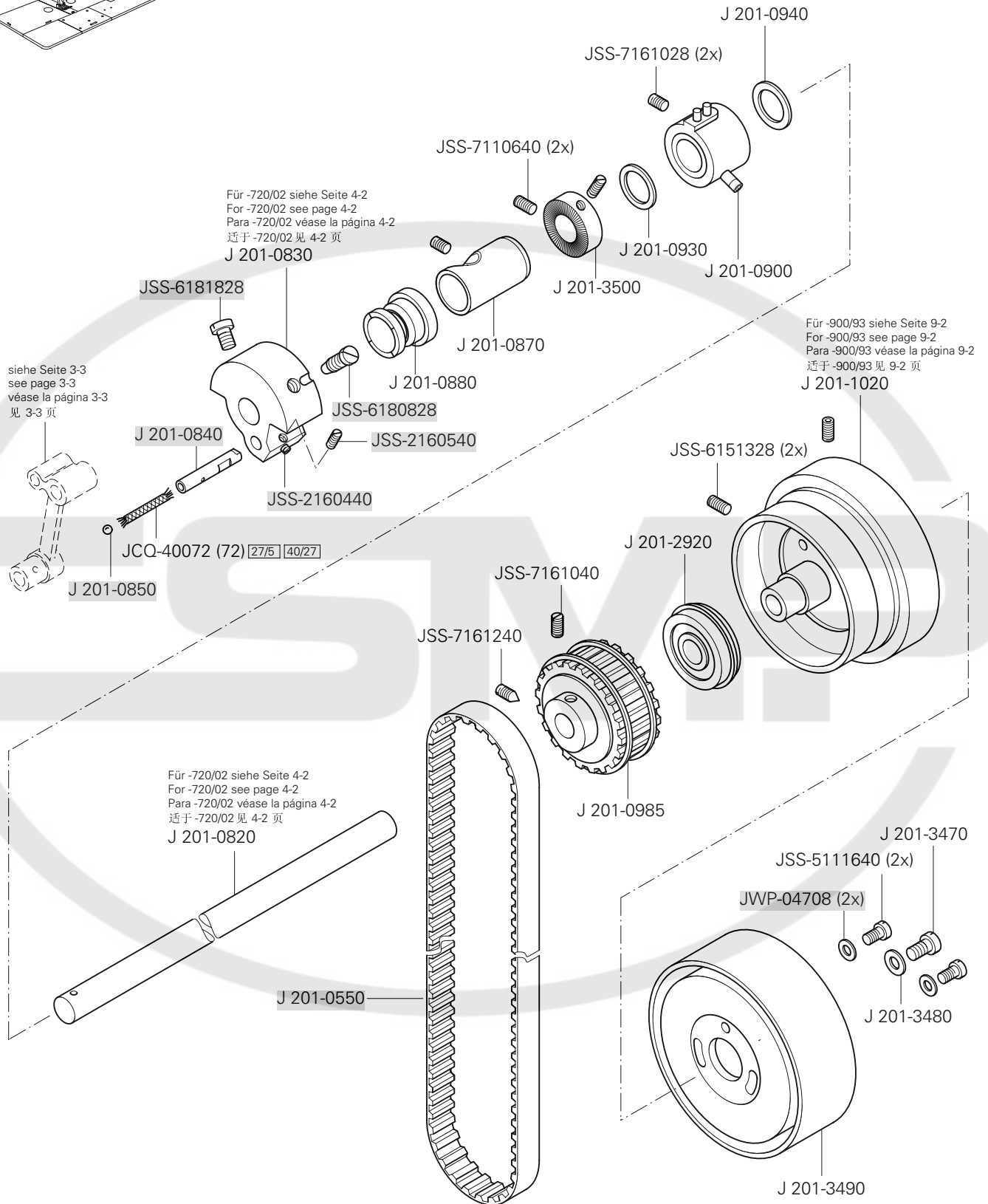

3.03

Armteile
Arm parts

Piezas del brazo
机臂零件

PFAFF 1122
PFAFF 1122-G

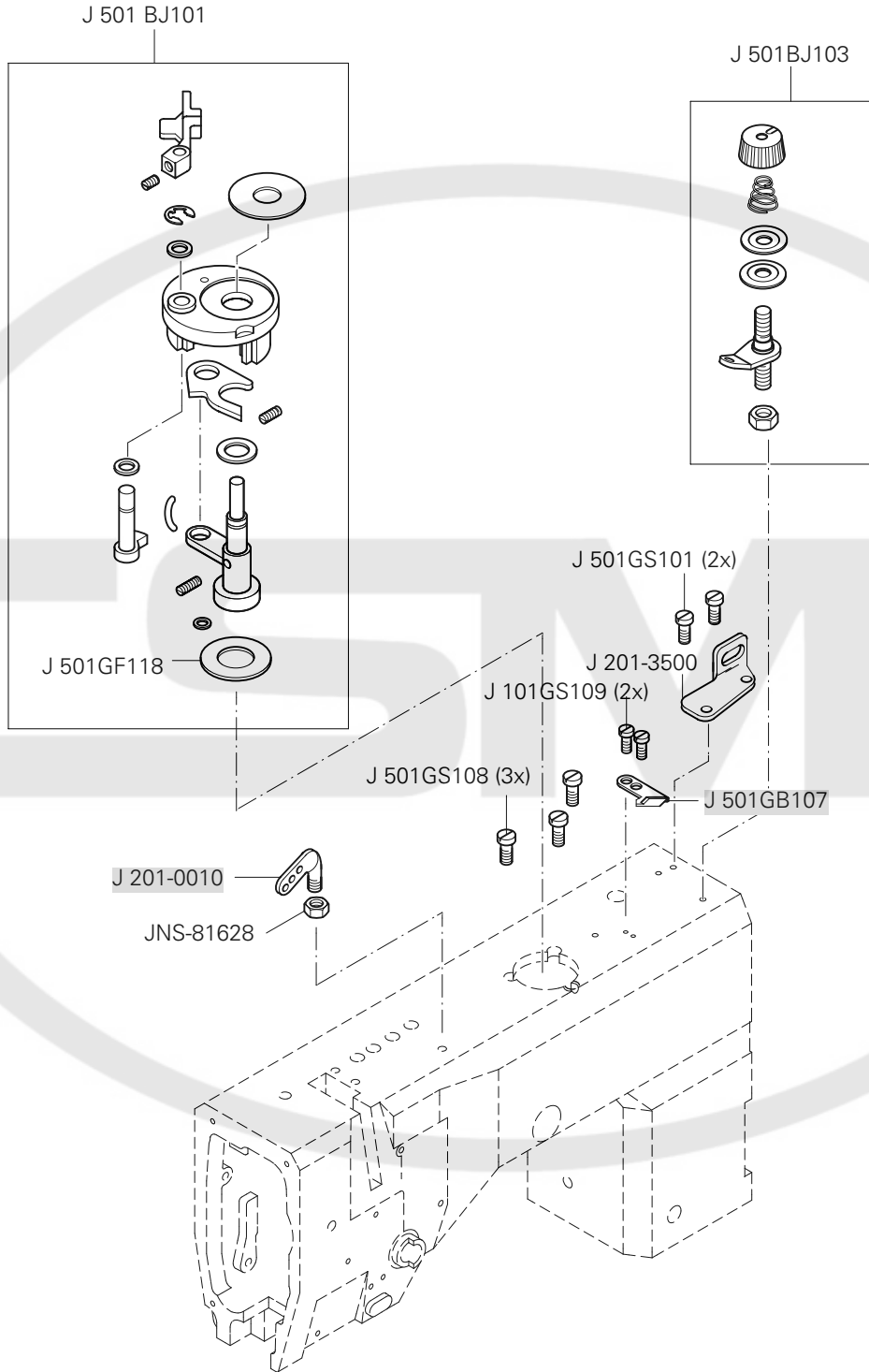
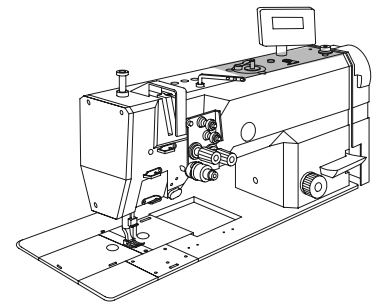

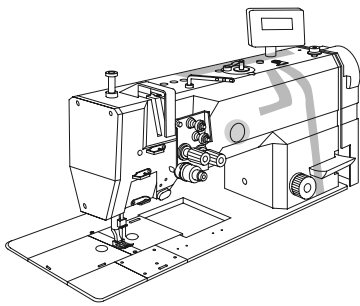

Armteile
 Arm parts
 Piezas del brazo
 机臂零件

PFAFF 1122
 PFAFF 1122-G

3.03

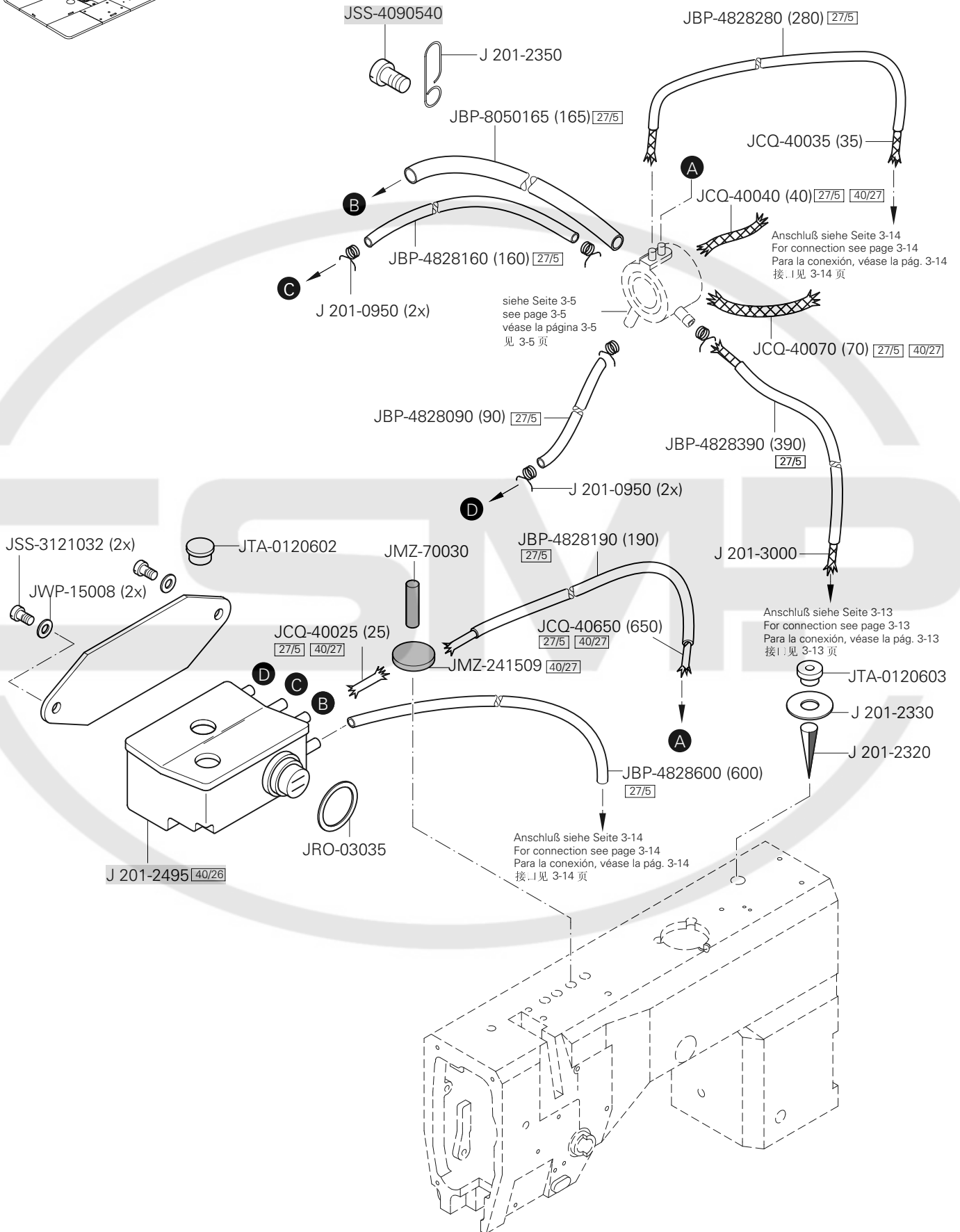

3.03

Armteile
 Arm parts
 Piezas del brazo
 机臂零件

PFAFF 1122
 PFAFF 1122-G

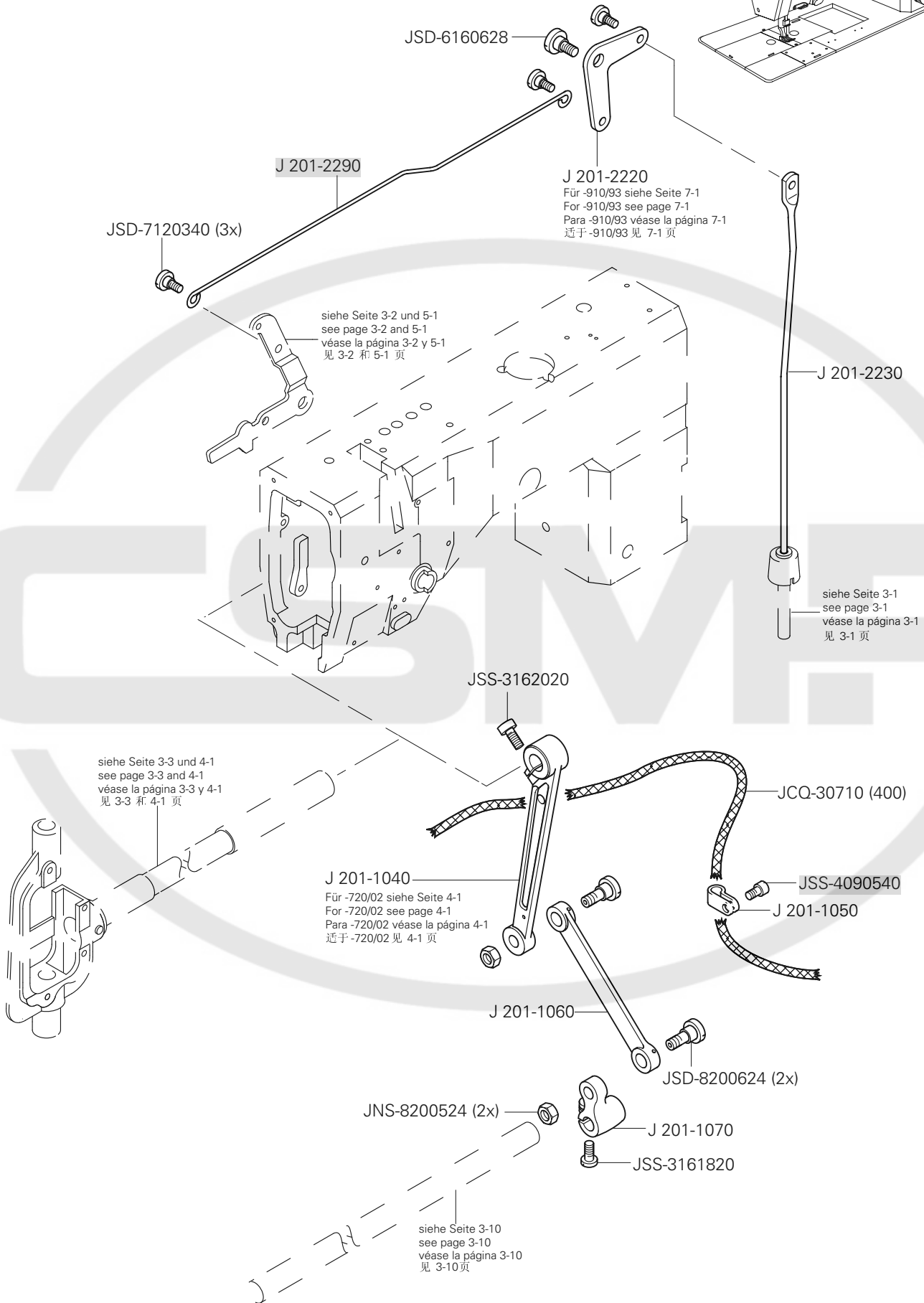
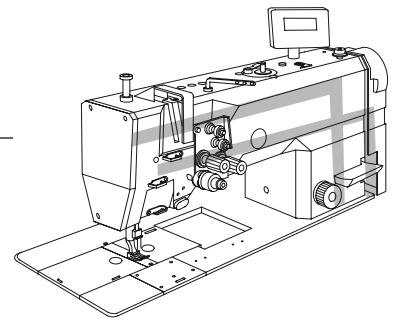

Armteile
 Arm parts
 Piezas del brazo
 机臂零件

PFAFF 1122
 PFAFF 1122-G

3.03

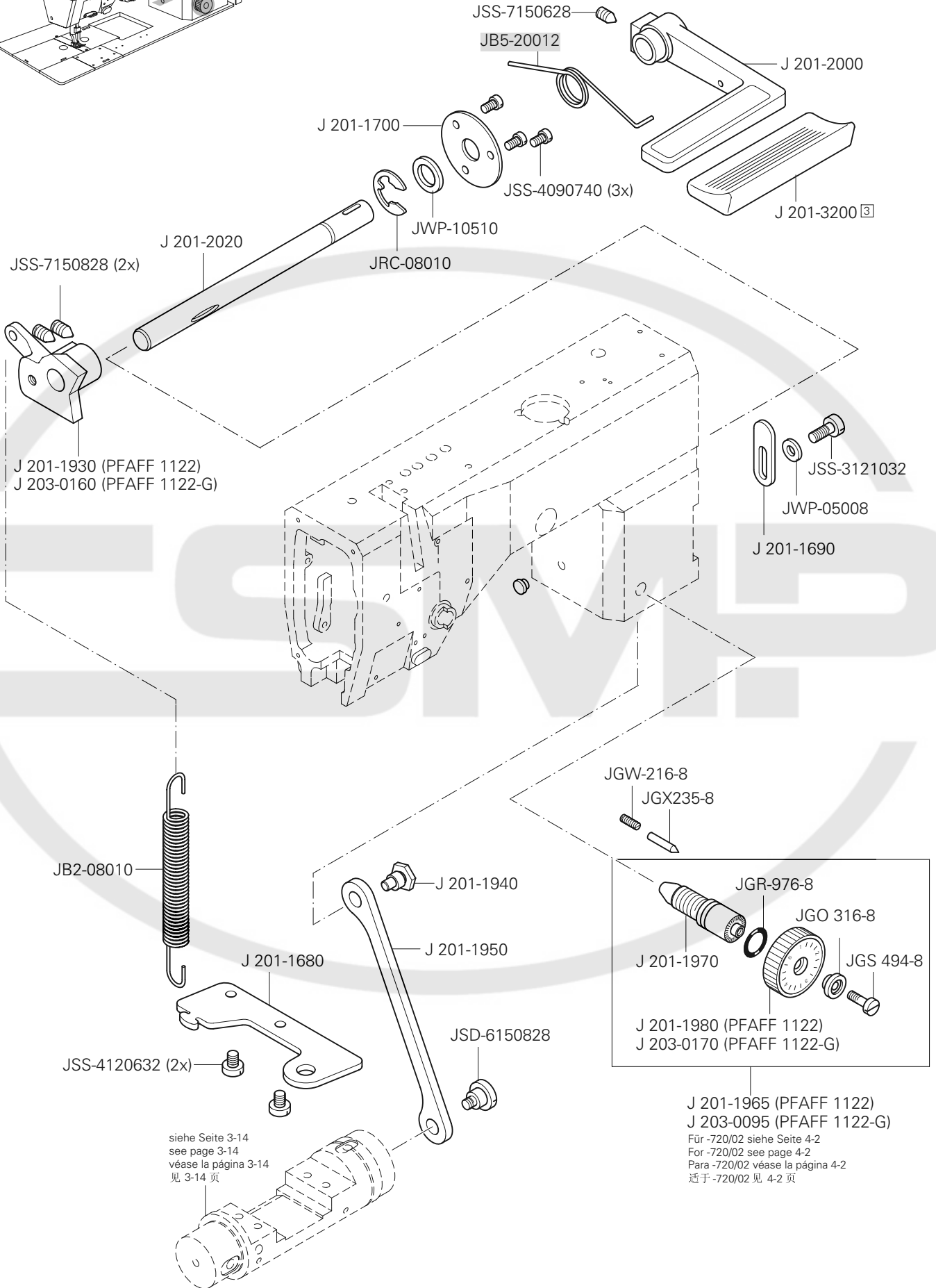
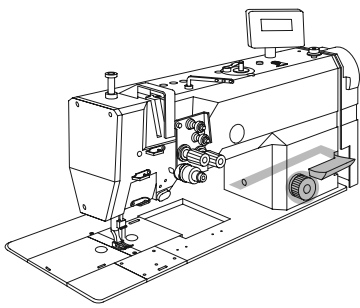

3.04

Grundplattenteile
Bedplate parts
Piezas del cárter
底板零件

PFAFF 1122
PFAFF 1122-G

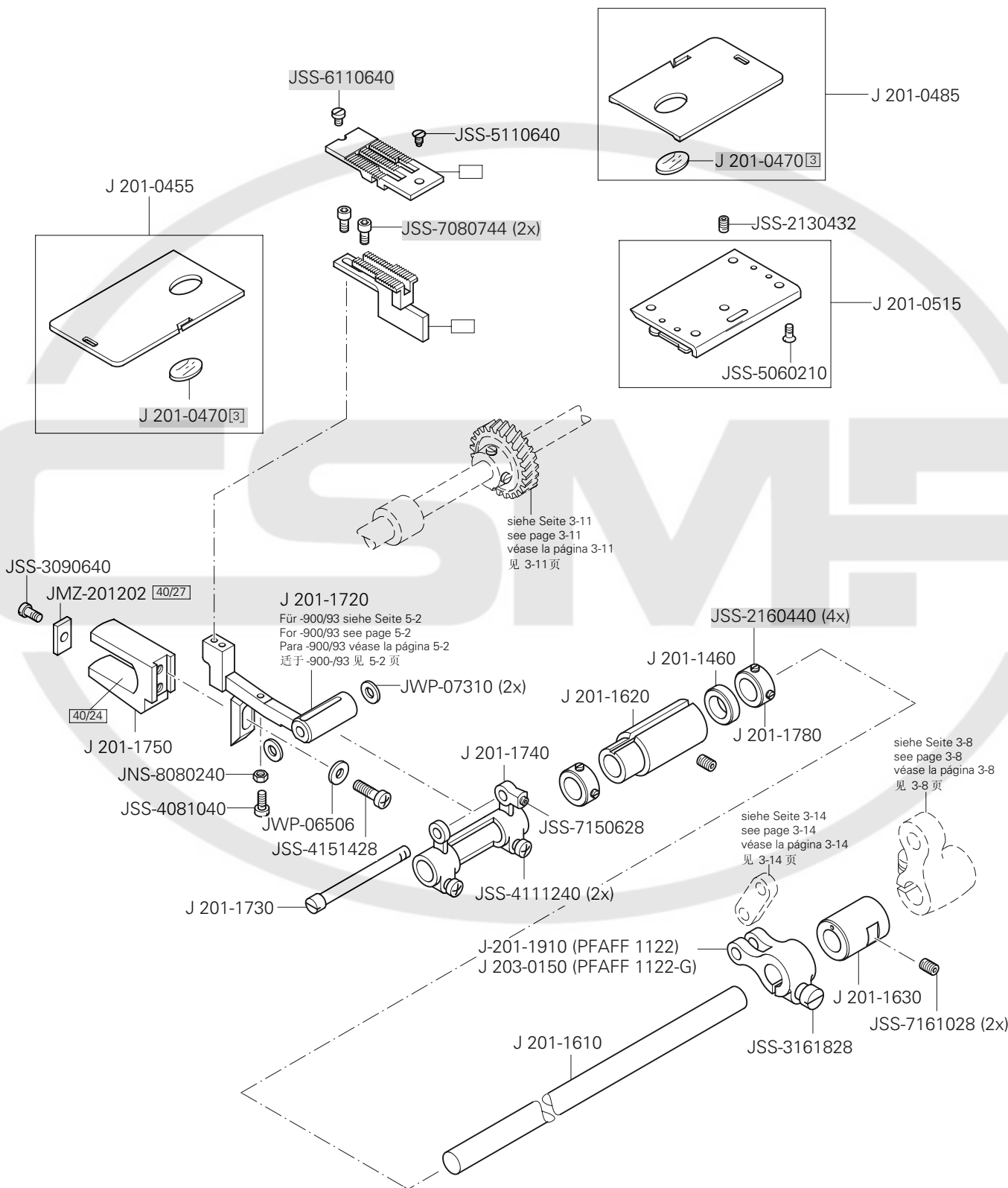
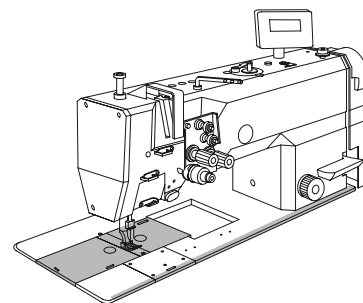

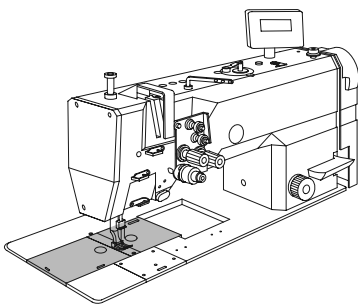

Grundplattenteile
Bedplate parts
Piezas del cárter
底板零件

PFAFF 1122
PFAFF 1122-G

3.04

- J 201-2970 (PFAFF 1122) A B
- J 202-2970 (PFAFF 1122) C
- J 203-0180 (PFAFF 1122-G) A B C

für -720/02; -900/93 siehe Seite 4-3 und 5-2
for -720/02; -900/93 see page Seite 4-3 and 5-2
para -720/02; -900/93 véase la página 4-3 y 5-2
适于 -720/02; -900/93 见 4-3 和 5-2 页



- J 201-1180 (PFAFF 1122)
- J 203-0060 (PFAFF 1122-G)

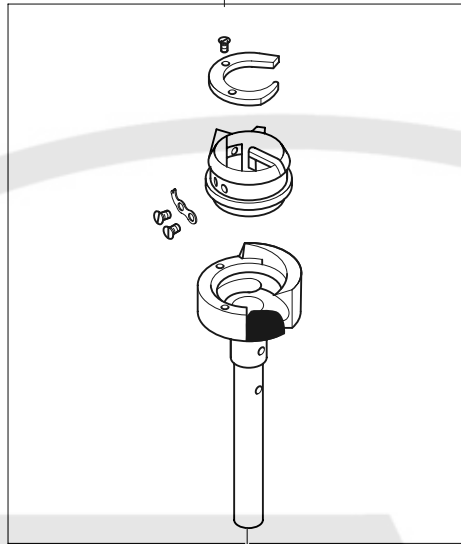

- J 201-1200 (2x) (PFAFF 1122)
- J 203-0080 (2x) (PFAFF 1122-G)

siehe Seite 3-14
see page 3-14
véase la página 3-14
见 3-14 页

- J 201-1320 (2x) (PFAFF 1122)
- J 203-0100 (2x) (PFAFF 1122-G)

- J 201-1280 (2x)

- J 203-1190 (2x) (PFAFF 1122)
- J 203-0070 (2x) (PFAFF 1122-G)

- JSS-5090440 (4x)

- J 201 1370

- J 201-2810 (2x)

- JRD-10810 (2x)

- J 201 1160

- J 201-1420

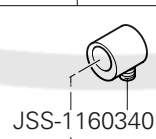

- JSS-1160340

- J 201-1335

- JCQ-40040 (40)

27/5 40/27

- JSS-1160340

- JSS-2160540 (3x)

Anschluß siehe Seite 3-12
For connection see page 3-12
Para la conexión, véase la pág. 3-12
接口见 3-12 页

- J 201-1080
- J 201-1100

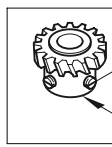

- JSS-2160540 (3x)

Anschluß siehe Seite 3-12
For connection see page 3-12
Para la conexión, véase la pág. 3-12
接口见 3-12 页

3.04

Grundplattenteile
Bedplate parts
Piezas del cárter
底板零件

PFAFF 1122
PFAFF 1122-G

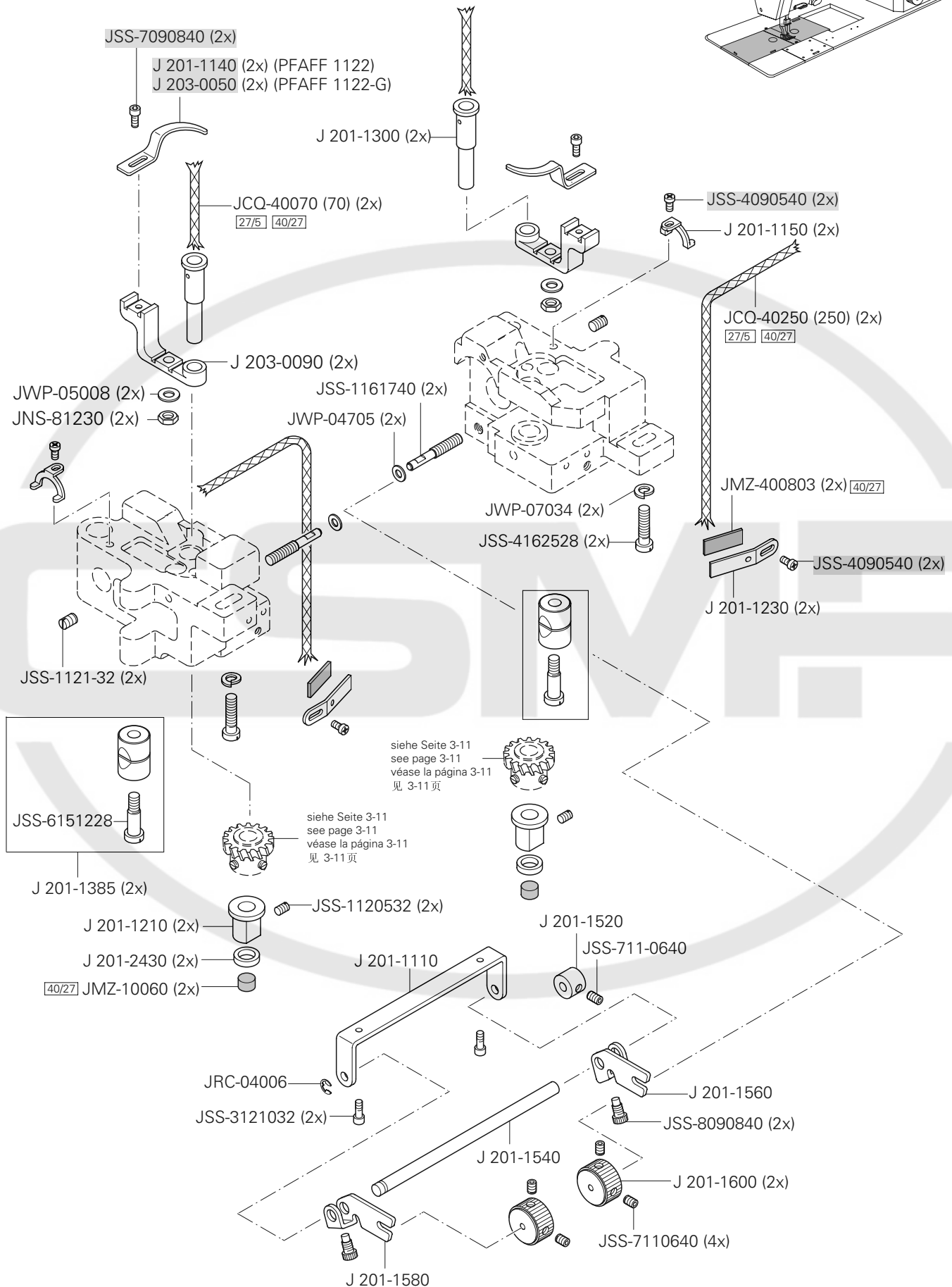
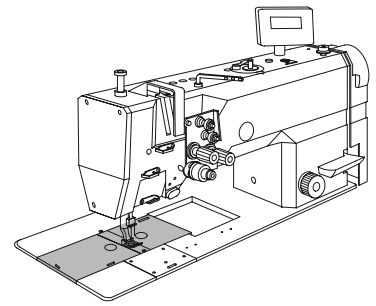

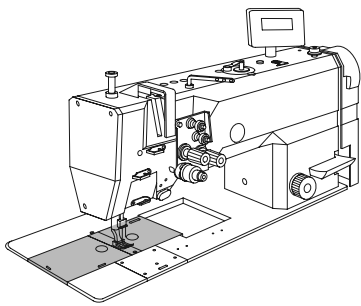

Grundplattenteile
Bedplate parts
Piezas del cárter
底板零件

PFAFF 1122
PFAFF 1122-G

3.04

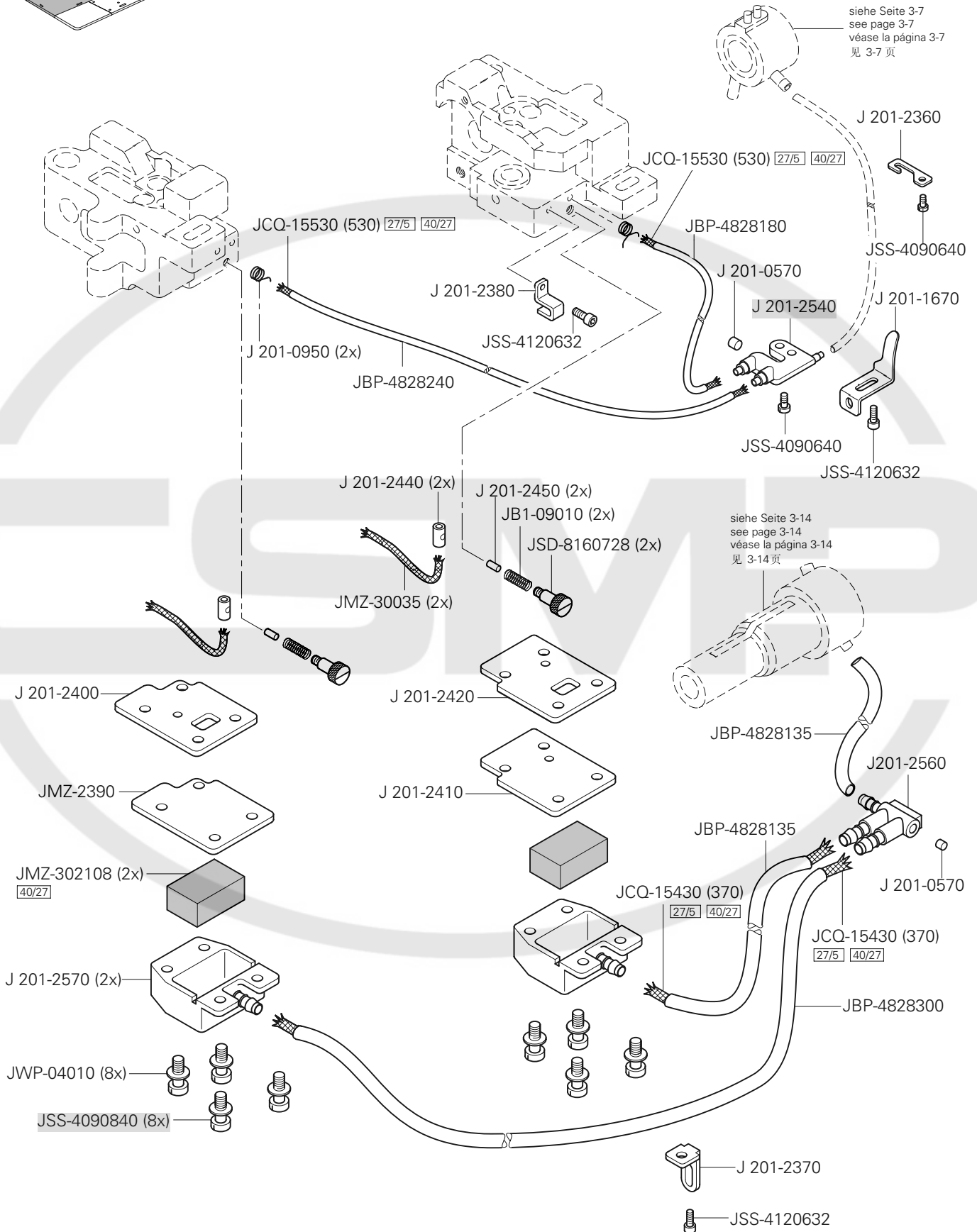

3.04

Grundplattenteile Bedplate parts Piezas del cárter 底板零件

PFAFF 1122
PFAFF 1122-G

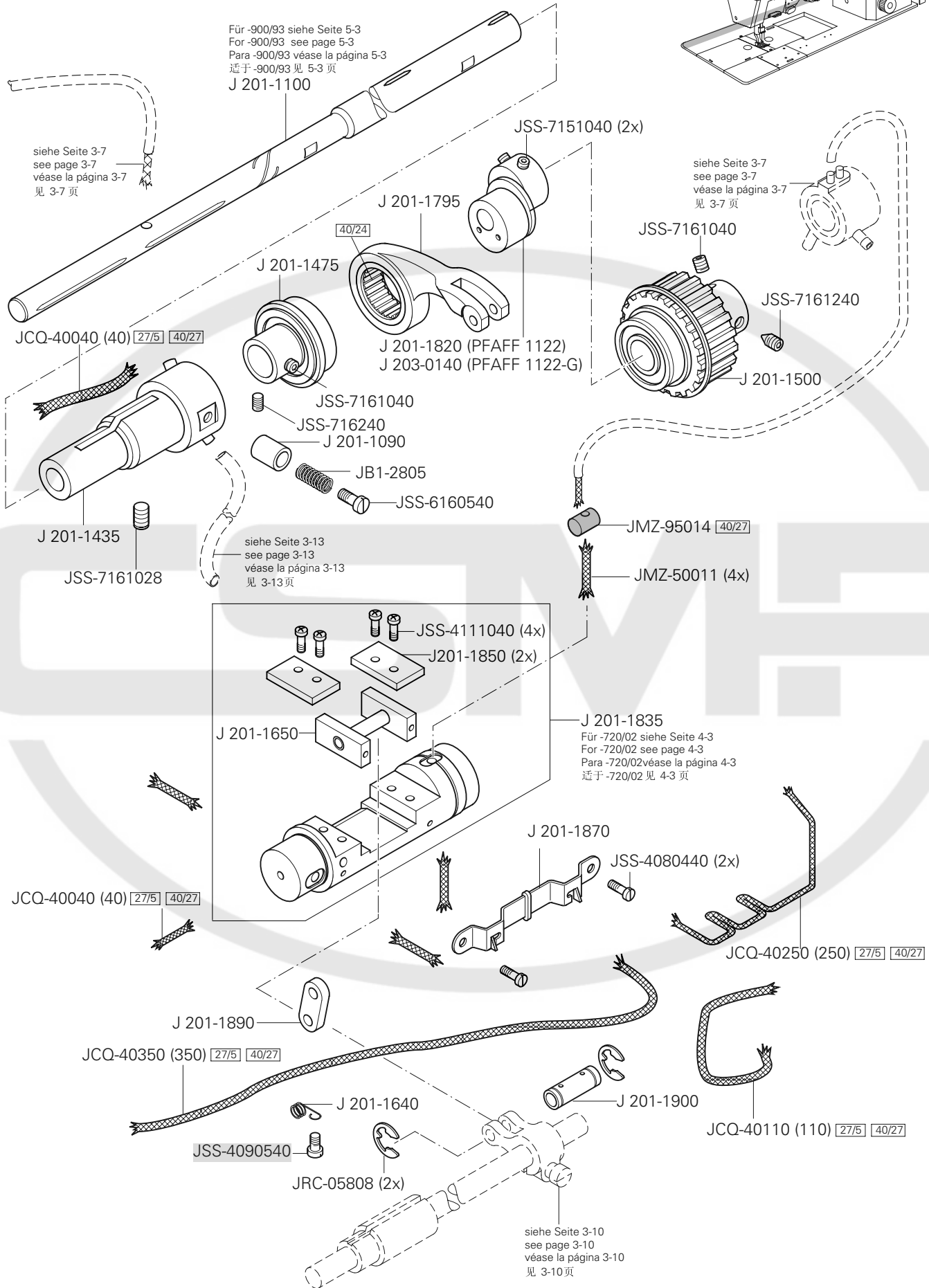
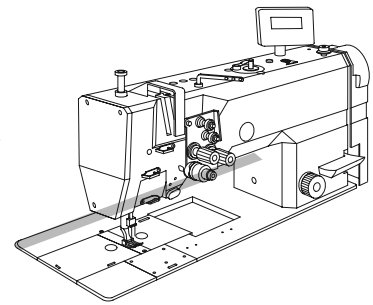

Nadelstangen-Schalteinrichtung (-720/02)
 Disengageable right and left needles (-720/02)
 Barra de aguja desconectable a izquierda (-720/02)
 针杆开关装置 (-720/02)

PFAFF 1122
 PFAFF 1122-G

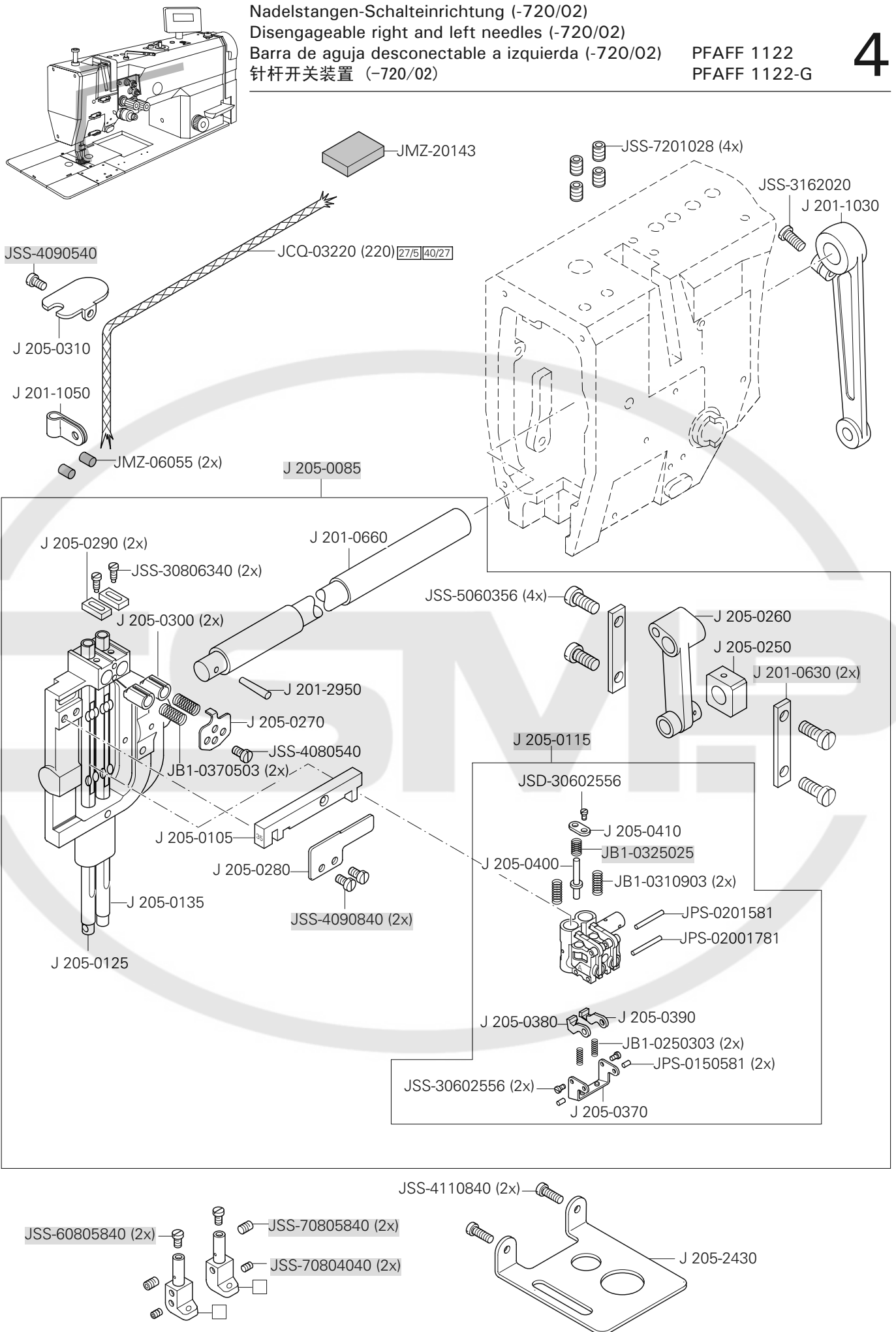

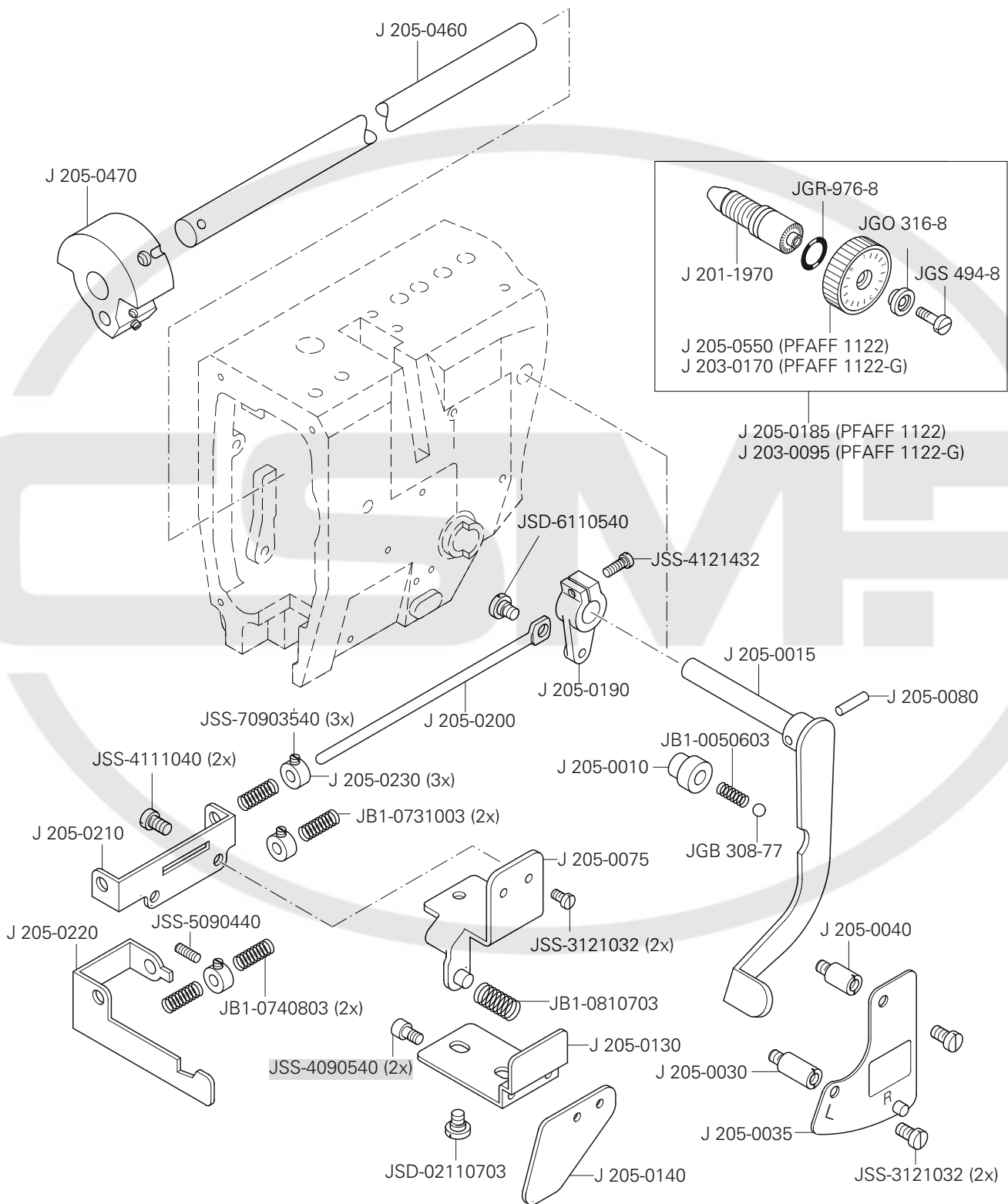
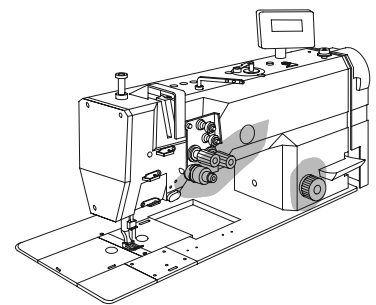

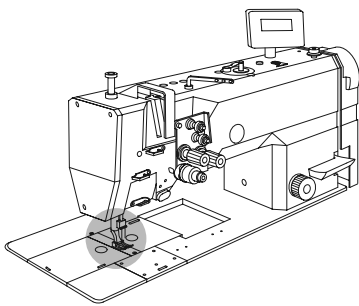

Nadelstangen-Schalteinrichtung (-720/02)
 Disengageable right and left needles (-720/02)
 Barra de aguja desconectable a izquierda (-720/02)
 针杆开关装置 (-720/02)

PFAFF 1122
 PFAFF 1122-G

Für -900/93 siehe Seite 5-2
 For -900/93 see page 5-2
 Para -900/93 véase la página 5-2
 适于-900/93 见 5-2 页

J 205-2970 (PFAFF 1122) A B C
 J 208-0020 (PFAFF 1122-G) A B C

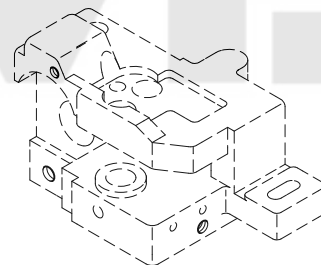
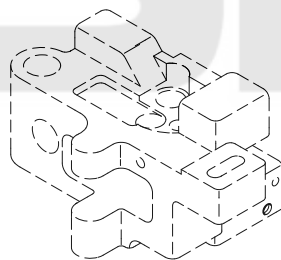
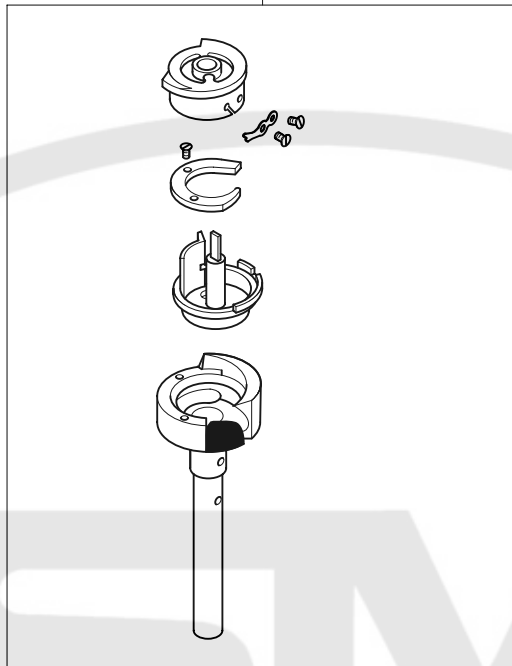

J 205-0175

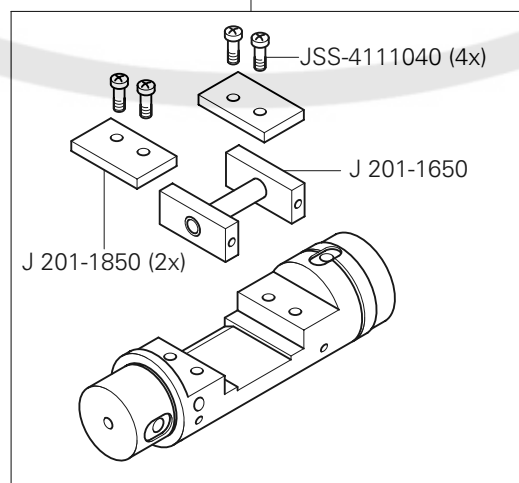

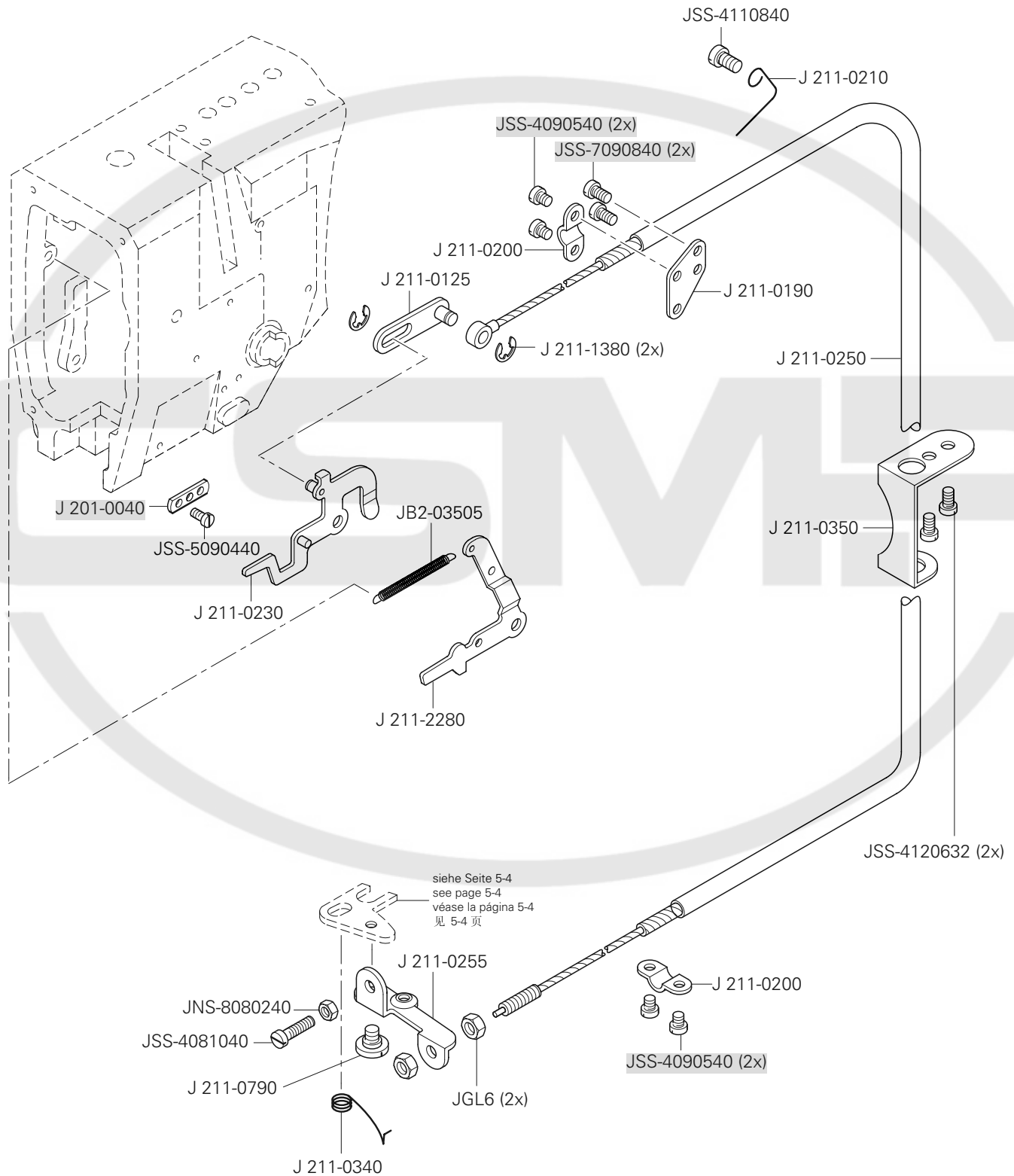
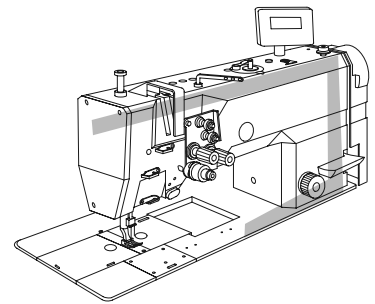

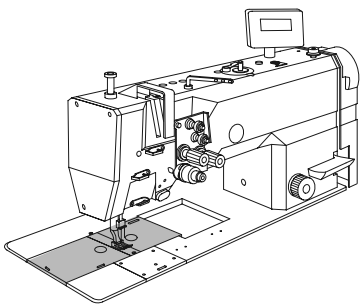

Fadenabschneid-Einrichtung (-900/93)
 Thread trimmer (-900/93)
 Cortahilos (-900/93)
 切线器 (-900/93)

PFAFF 1122
 PFAFF 1122-G

J 211-0940 (PFAFF 1122) A B C

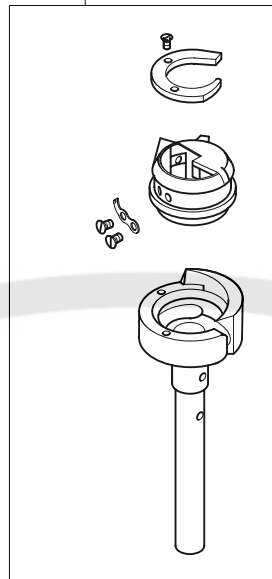

J 213-0940 (PFAFF 1122-720) A B C

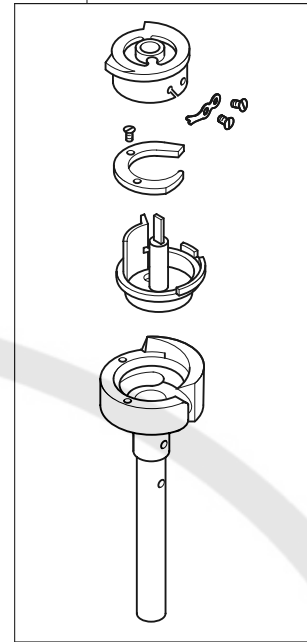

J 211-0670 (2x)

J 211-0680 (4x)

J 211-0690 (2x)

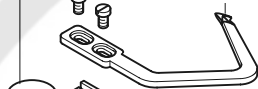

JSS-6080344 (4x)

J 211-0310 (2x)

JSS-709840 (4x)

J 211-0300 (2x)

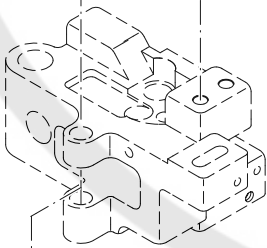

siehe Seite 5-3
 see page 5-3
 véase la página 5-3
 见 5-3 页

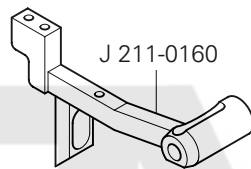

J 211-0160

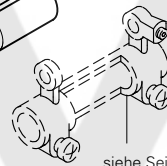

siehe Seite 3-10
 see page 3-10
 véase la página 3-10
 见 3-10 页

J 215-0020 (PFAFF 1122-G) A B C

J 221-0020 (PFAFF 1122-G-720) A B C

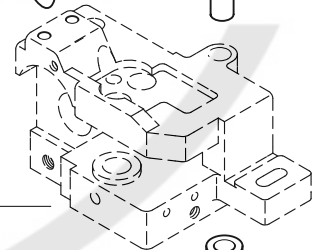
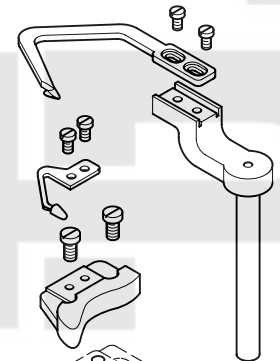
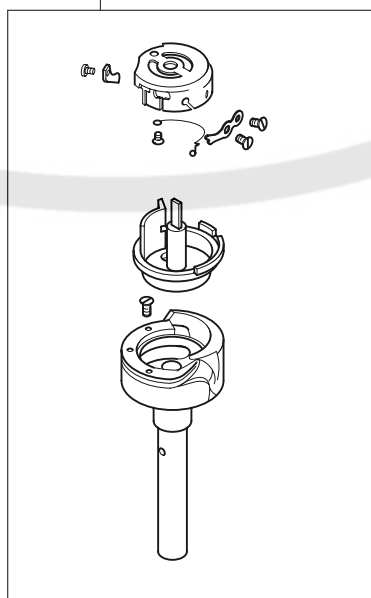

JRC-07912 (2x)

JSS-2160540 (4x)

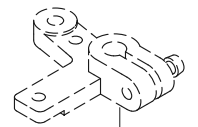

siehe Seite 5-3
 see page 5-3
 véase la página 5-3
 见 5-3 页

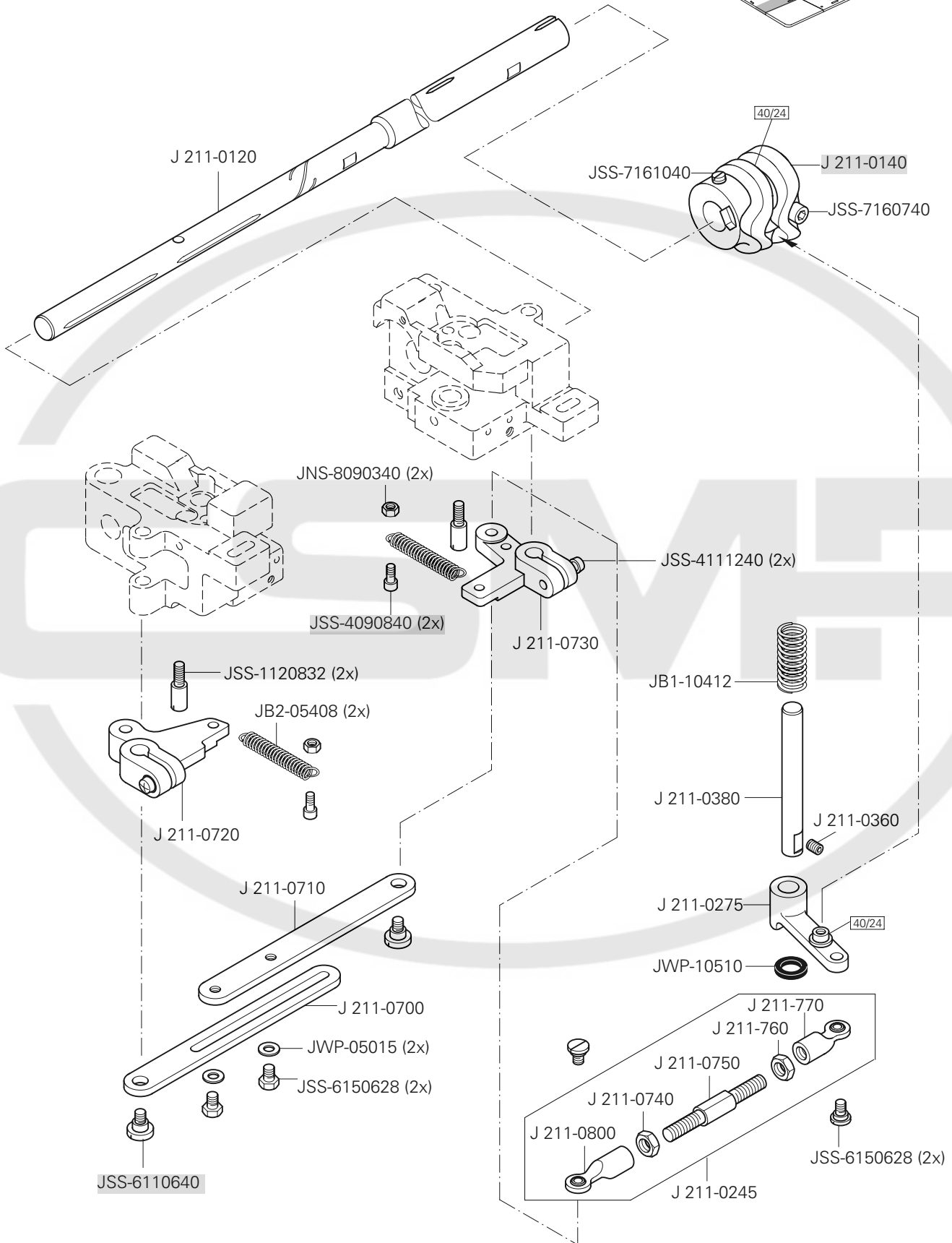
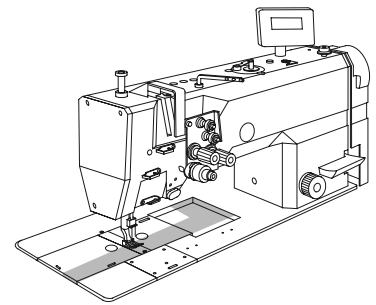

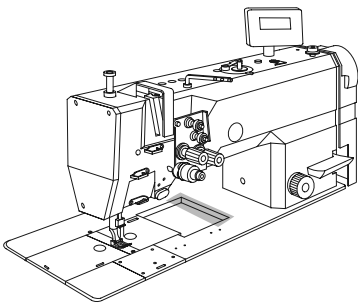

Fadenabschneid-Einrichtung (-900/93)
 Thread trimmer (-900/93)
 Cortahilos (-900/93)
 切线器 (-900/93)

PFAFF 1122
 PFAFF 1122-G

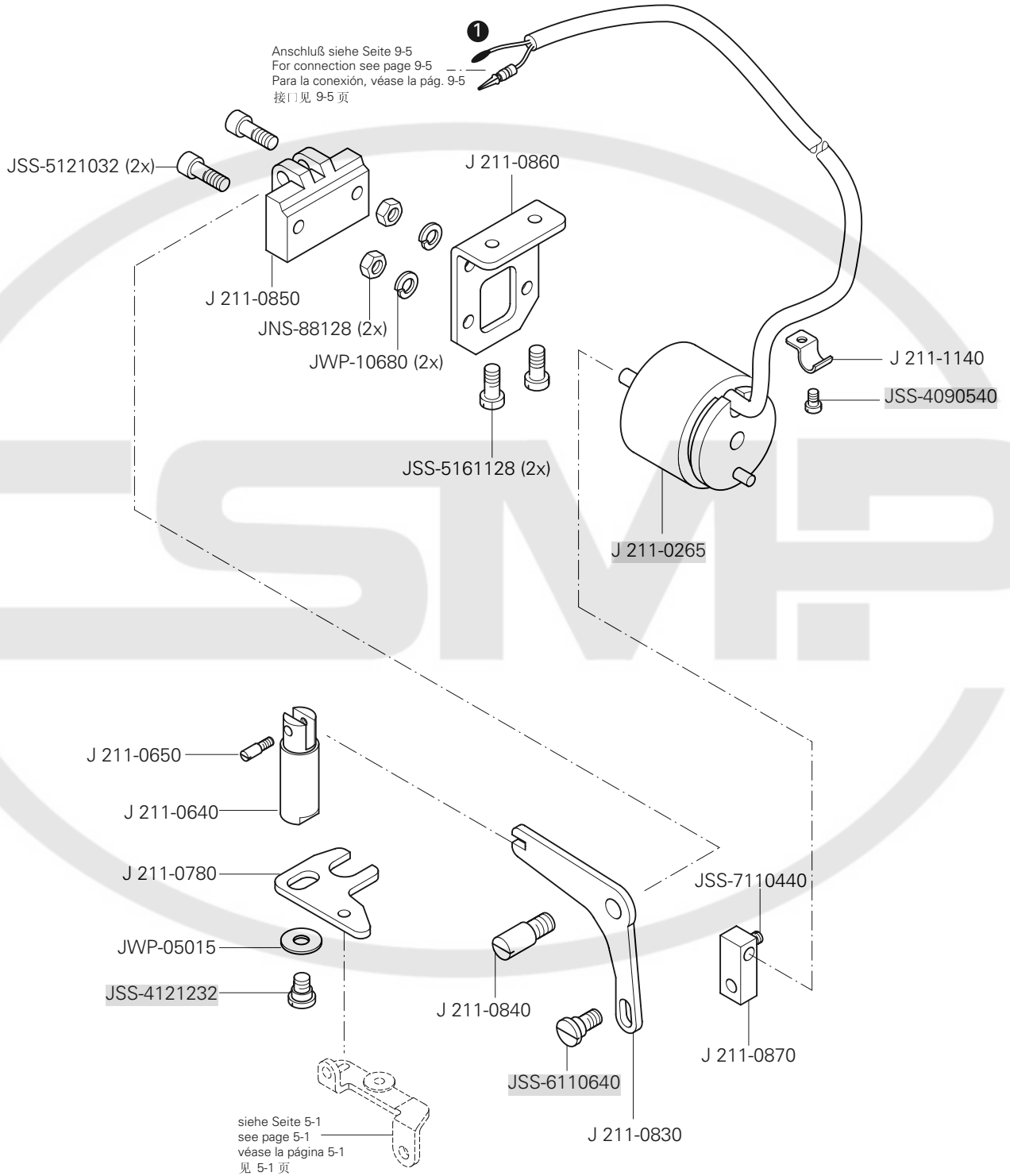

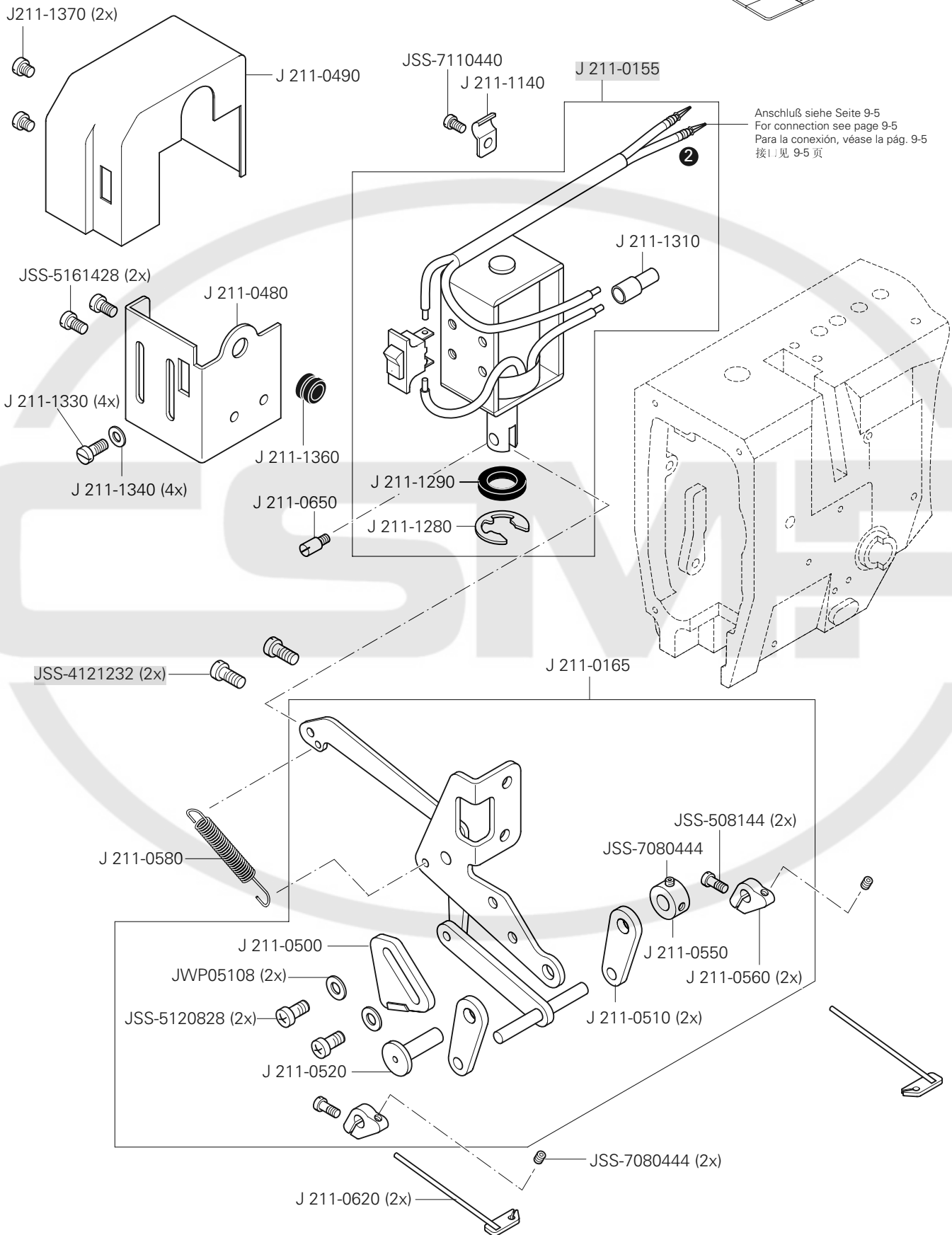
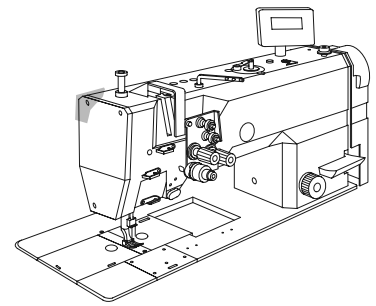

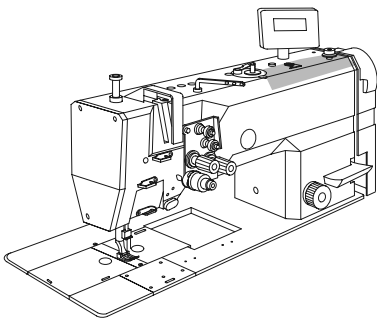

Presserfuß-Automatik (-910/93)
 Automatic presser lifter (-910/93)
 Alzaprensatelas (-910/93)
 压脚自动提升器 (-910/93)

PFAFF 1122
 PFAFF 1122-G

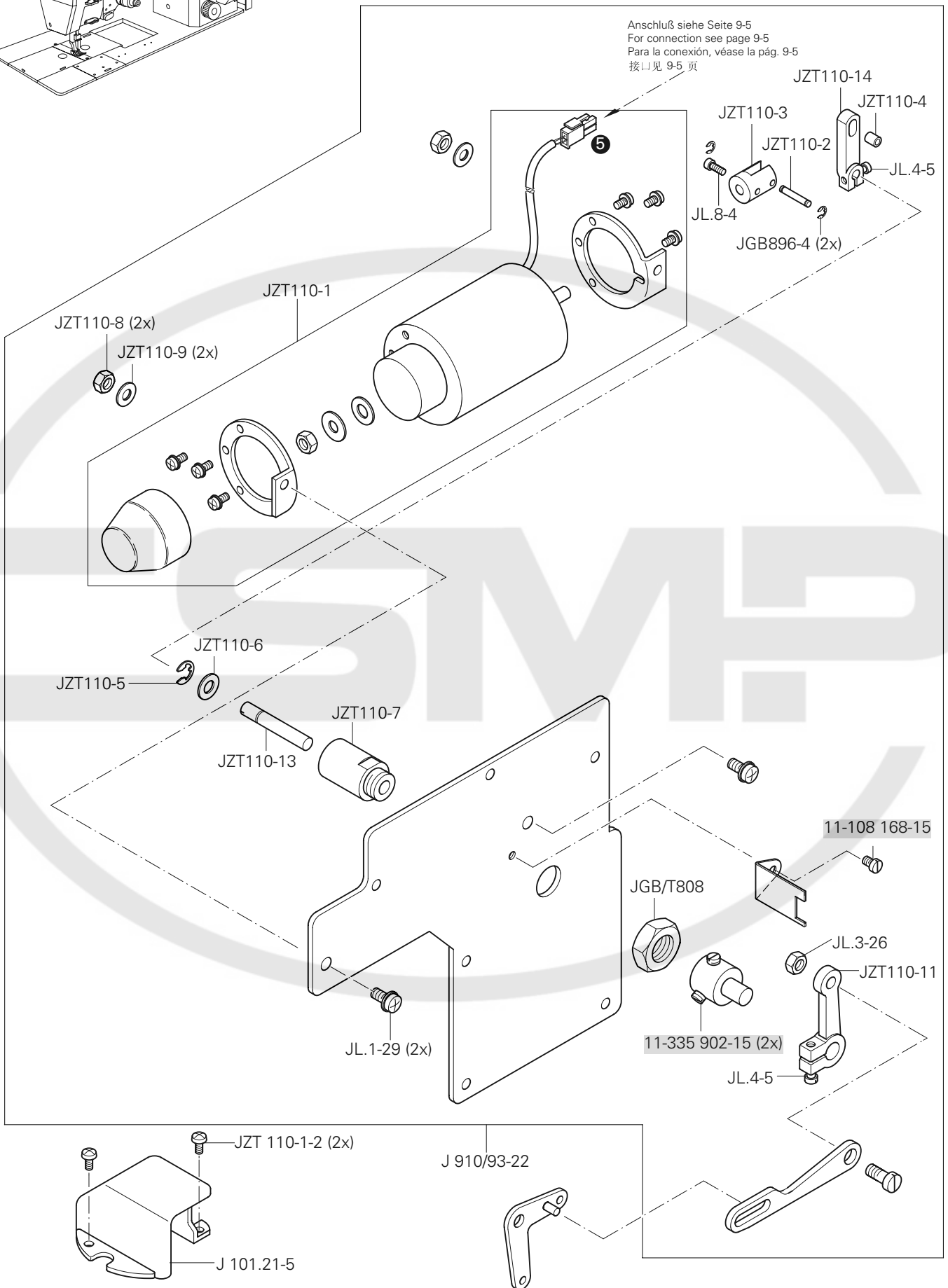

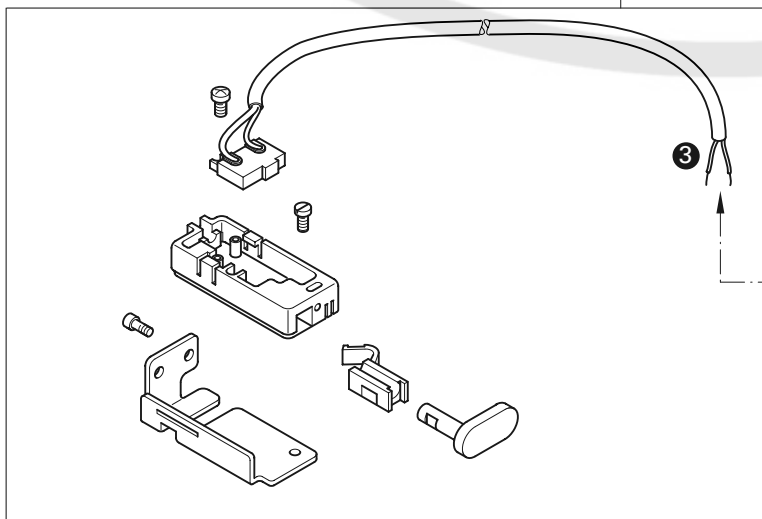
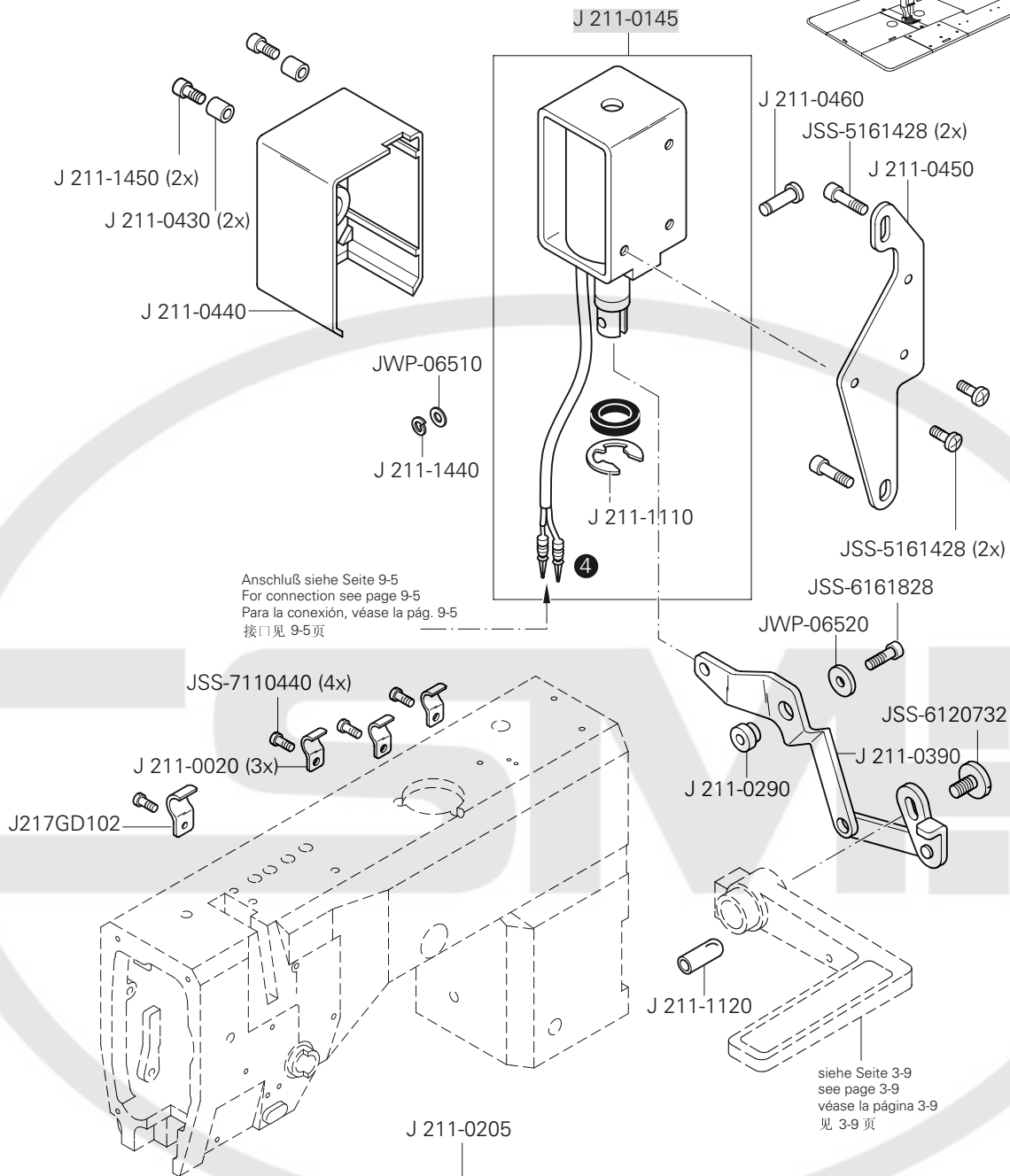
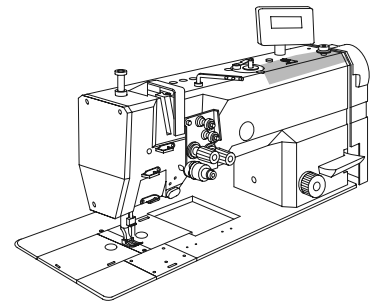

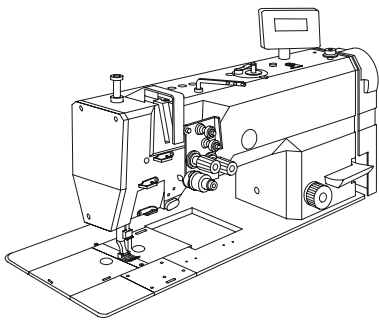

Bedienfeld
Control panel
Panel de mandos
操作板

PFAFF 1122
PFAFF 1122-G

9.01

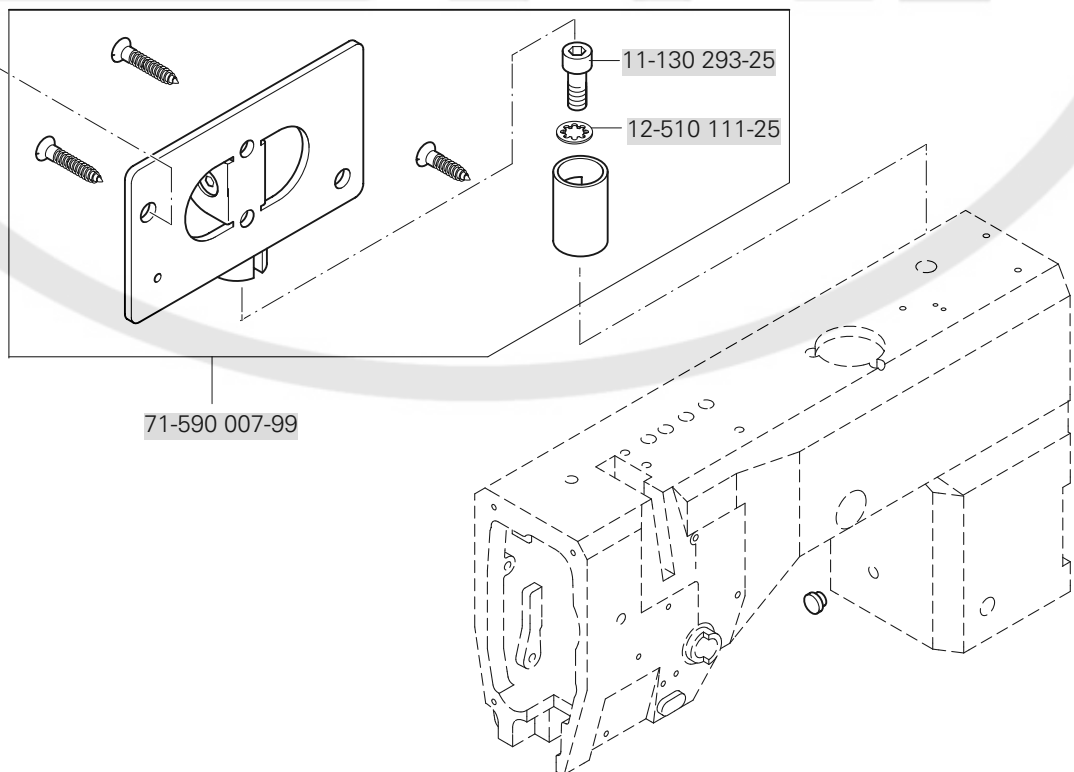
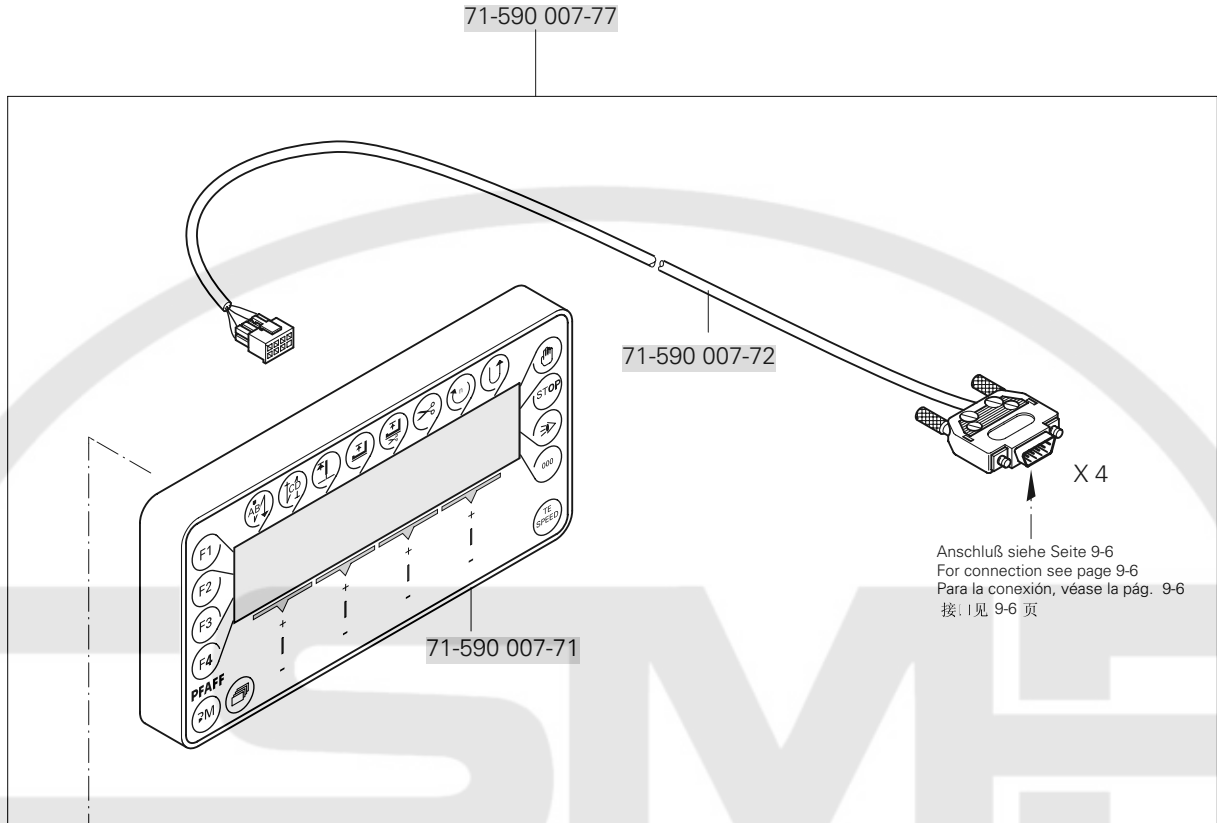

9.02

Oberteilerkennung
Sewing head identification
Detección de la parte superior
机头识别

PFAFF 1122
PFAFF 1122-G

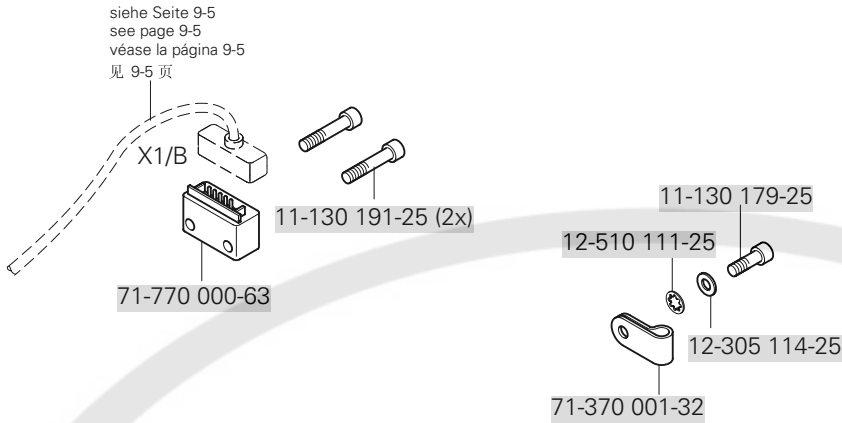
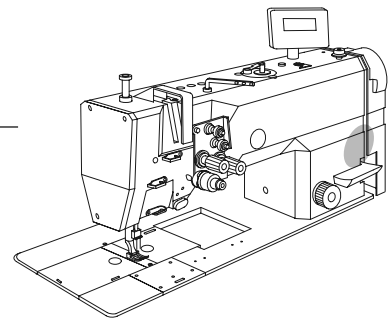

9.03

Positionsgeber
Synchronizer
Sincronizador
位置传感器

PFAFF 1122-900/93
PFAFF 1122-G-900/93

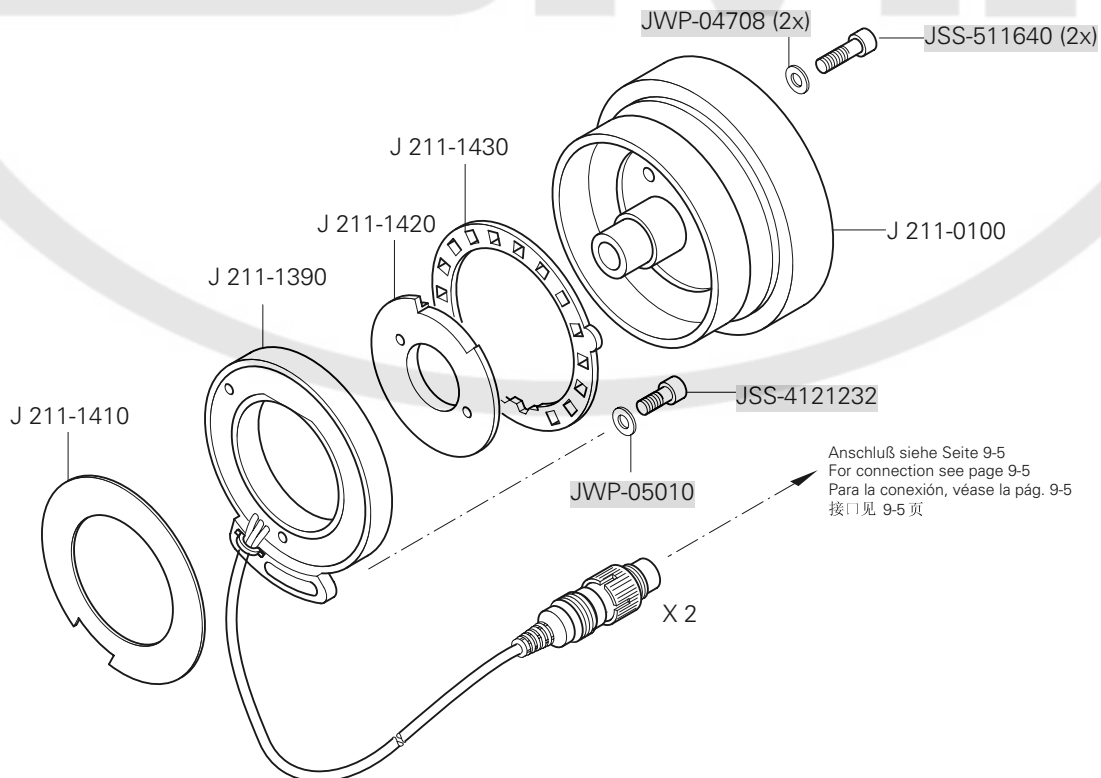
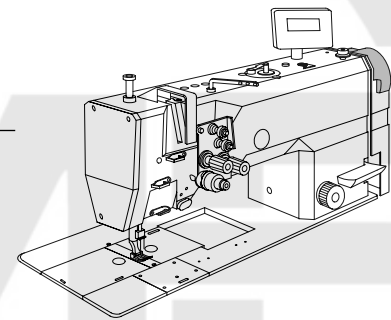

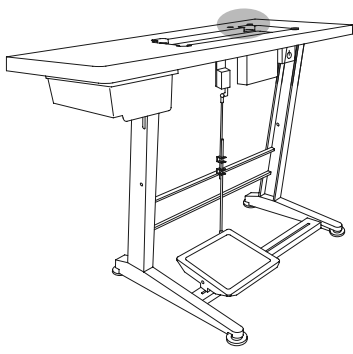

Einbaumotor
Built-in motor
Motor incorporado
内装式电机

PFAFF 1122
PFAFF 1122-G

9.04

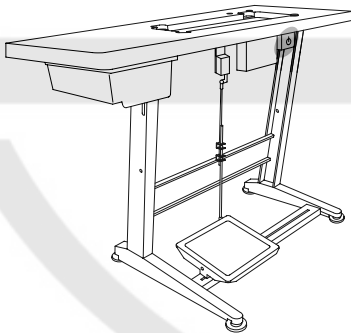
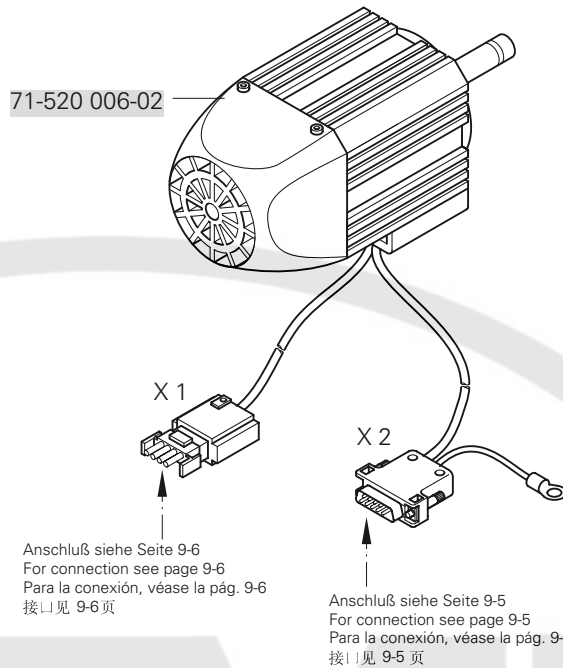

Motor-Hauptschalter
Main switch
Interruptor principal
电机主开关

PFAFF 1122
PFAFF 1122-G

9.05

71-370 001-08



11-460 163-15

Anschluß siehe Seite 9-6
For connection see page 9-6
Para la conexión, véase la pág. 9-6
接口见 9-6 页

91-229 180-90 

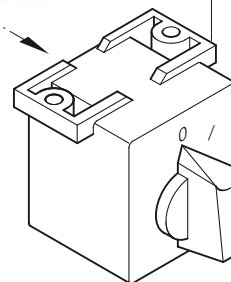

71-370 002-92



11-460 250-15 (2x)



9.06

Sollwertgeber
 Set-point generator
 Emisor del valor teórico PFAFF 1122
 给定值发生器 PFAFF 1122-G

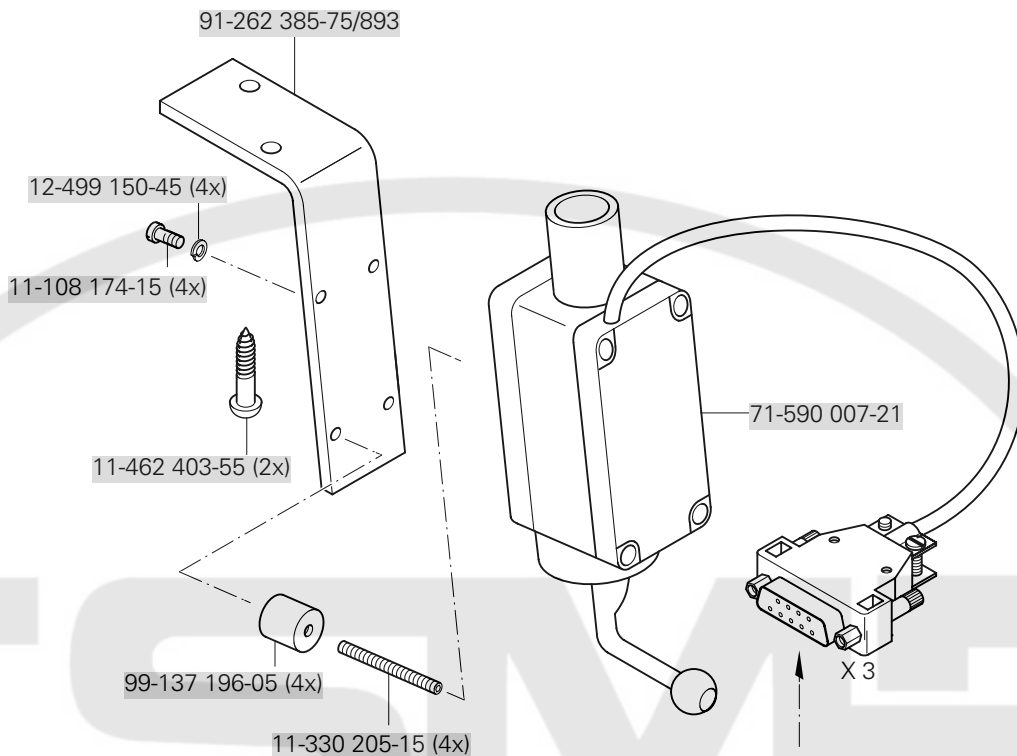
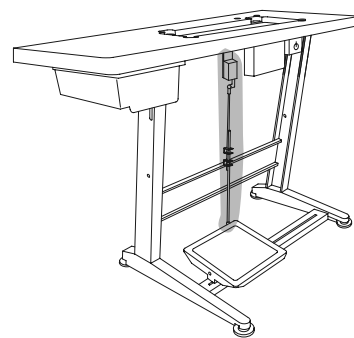

Anschluß siehe Seite 9-6
 For connection see page 9-6
 Para la conexión, véase la pág. 9-6
 接口见 9-6页

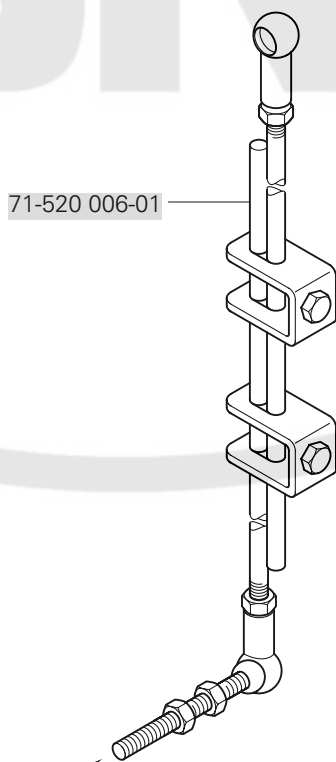

Zur Tretplatte
 For the pedal
 Para el pedal
 用于踏板

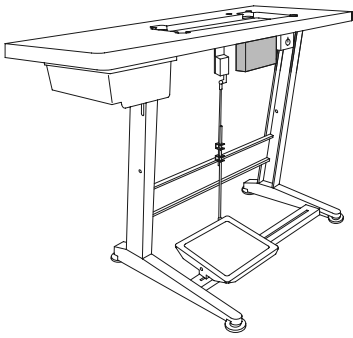

Steuerkasten
Control box
Caja de mandos
控制箱

PFAFF 1122
PFAFF 1122-G

9.07

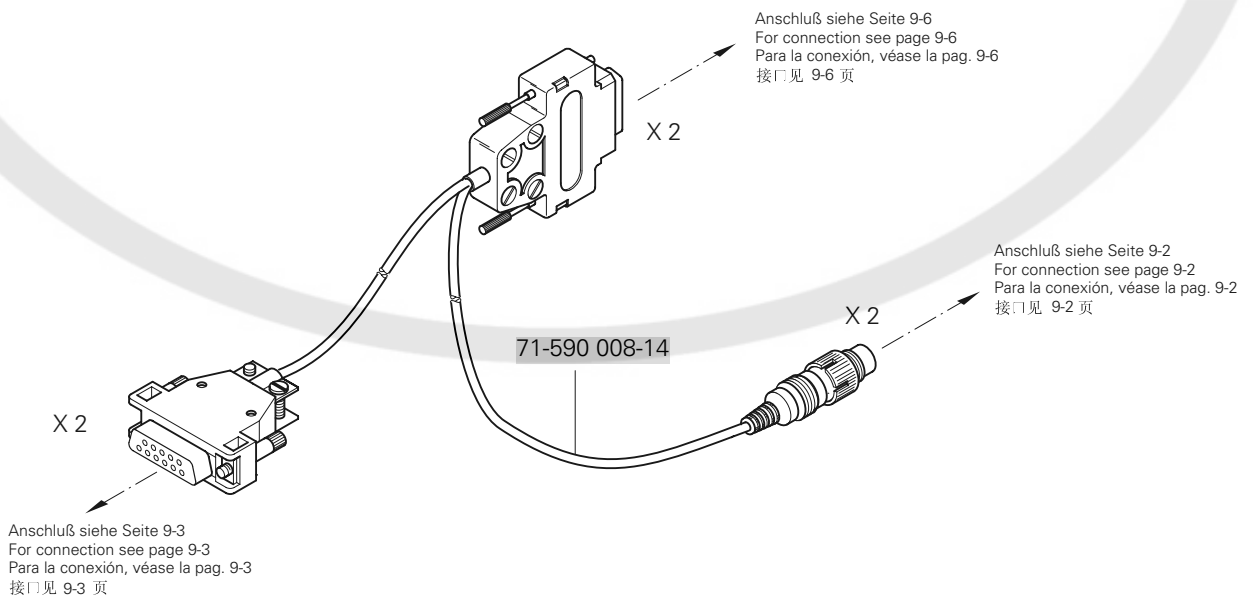
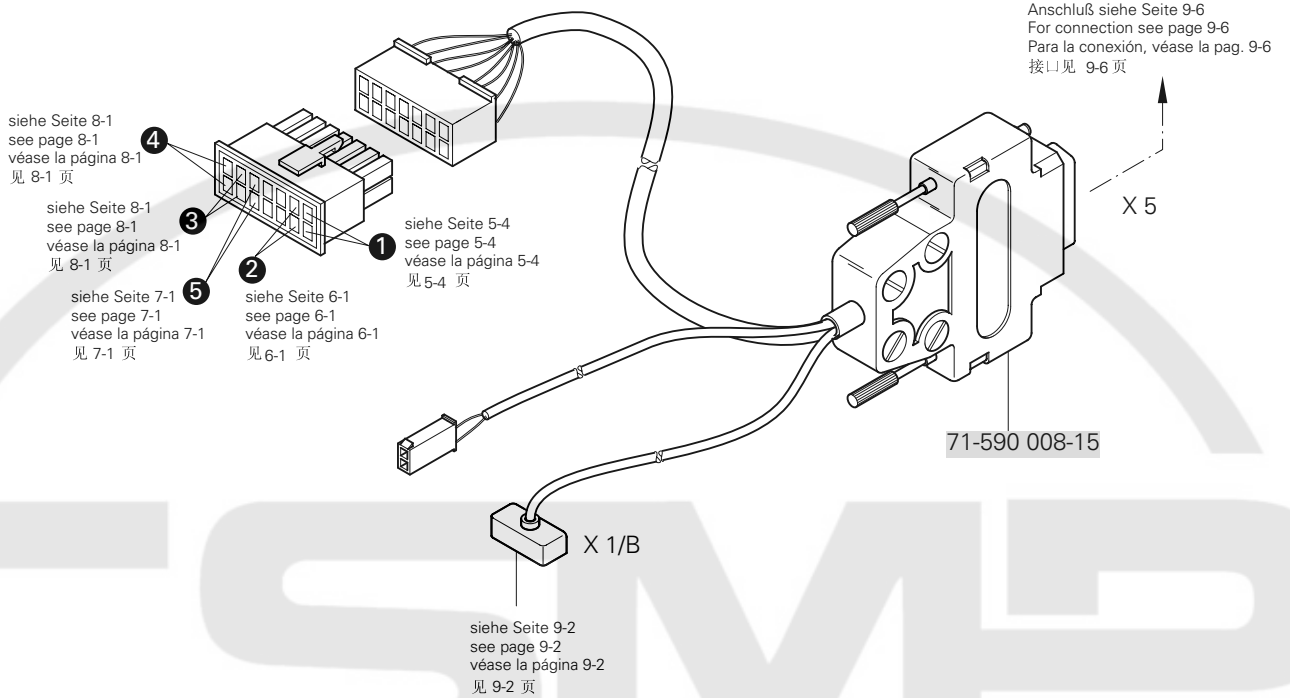

9.07

Steuerkasten
Control box
Caja de mandos
控制箱

PFAFF 1122
PFAFF 1122-G

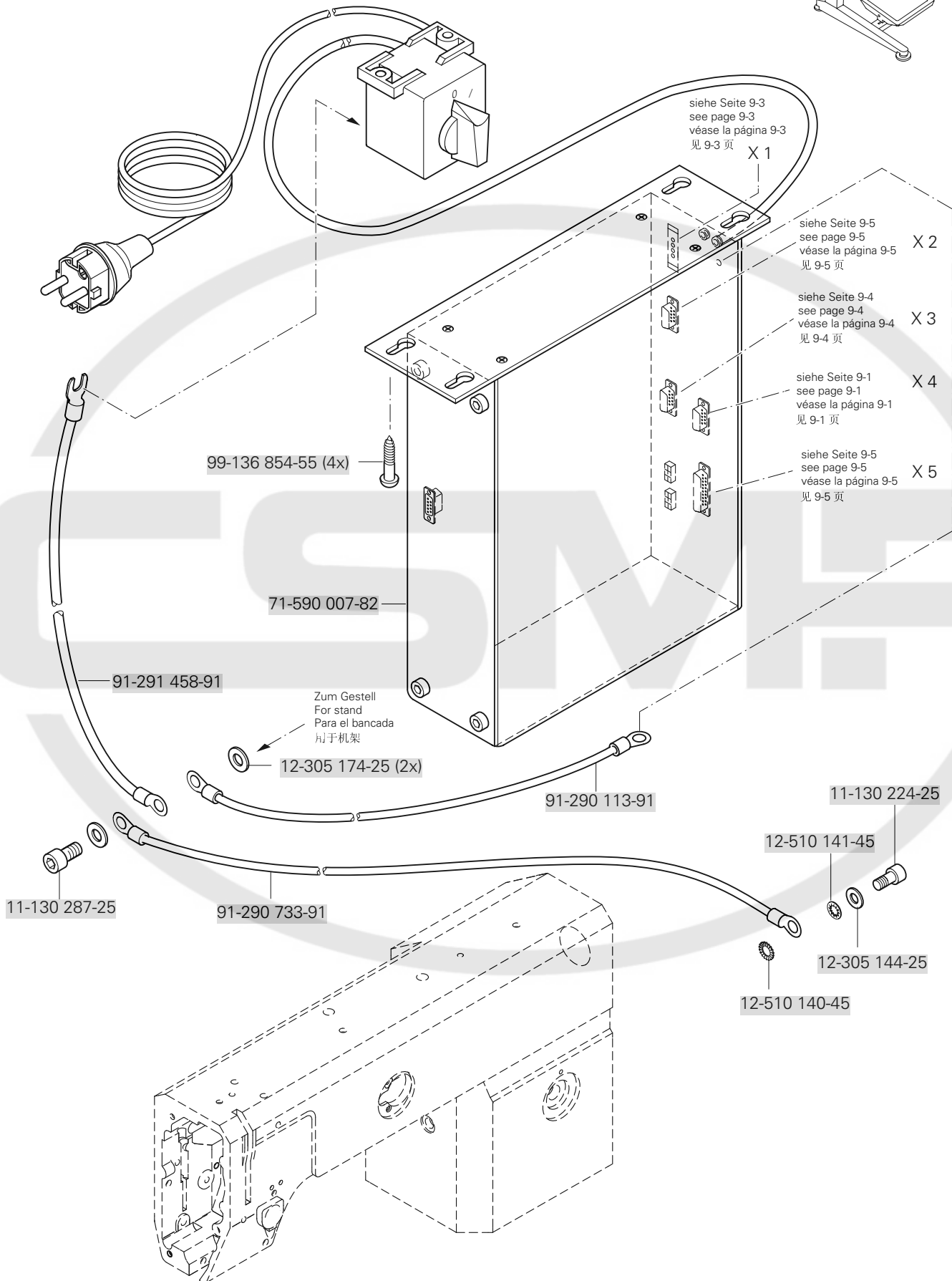
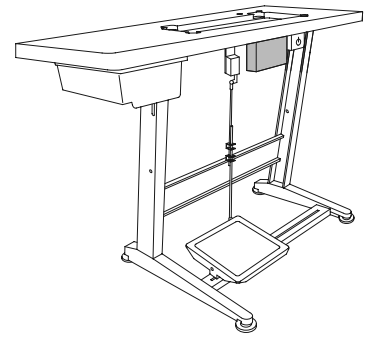

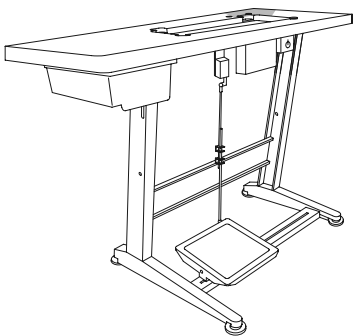

Garnrollenständer
 Reel stands
 Portacarretes
 线轴支架

PFAFF 1122
 PFAFF 1122-G

10

J 201-4000

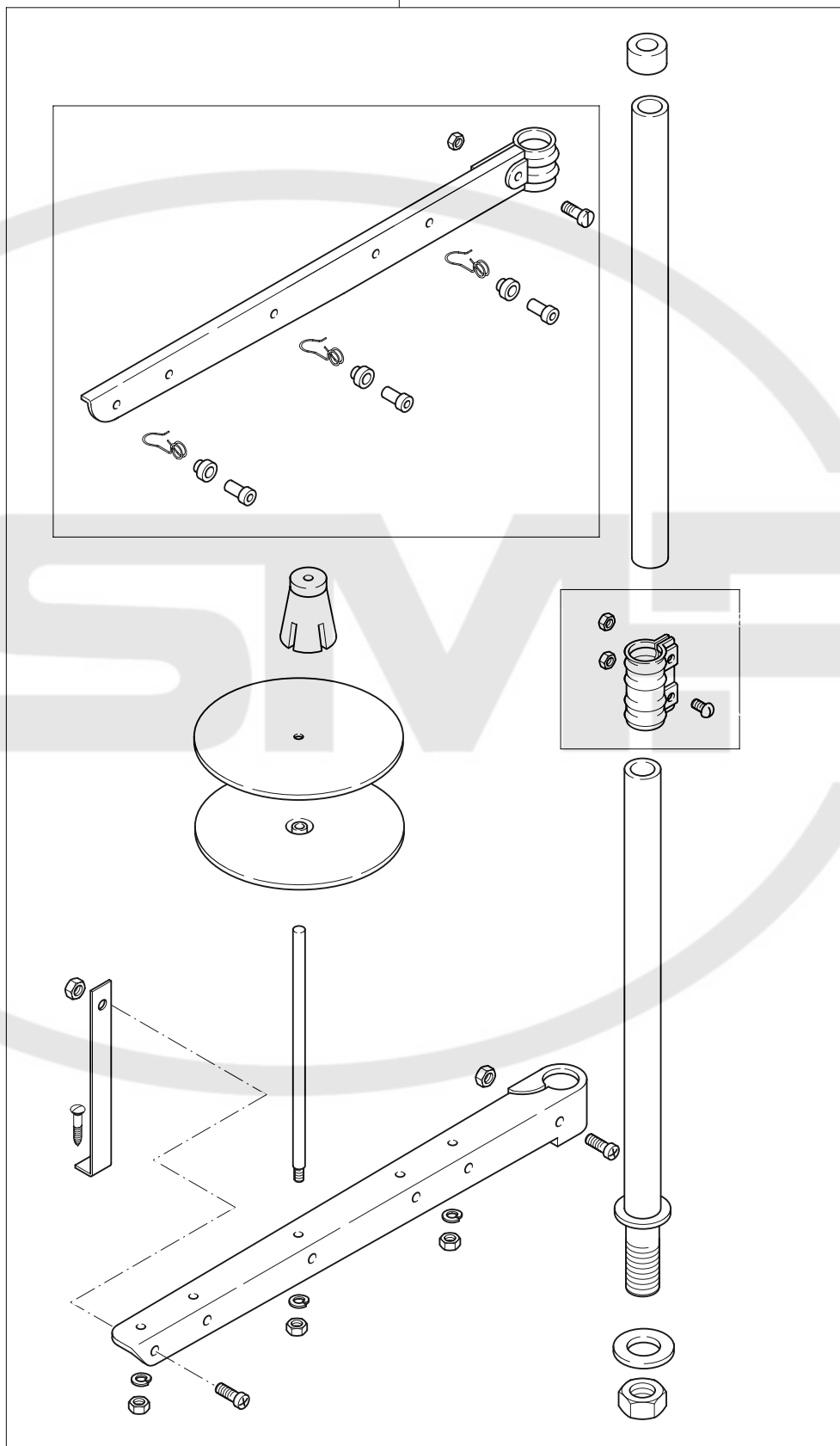

11

Teile zur Tischplatte
Parts for table top
Piezas para el tablero
用于台板的零件

PFAFF 1122
PFAFF 1122-G

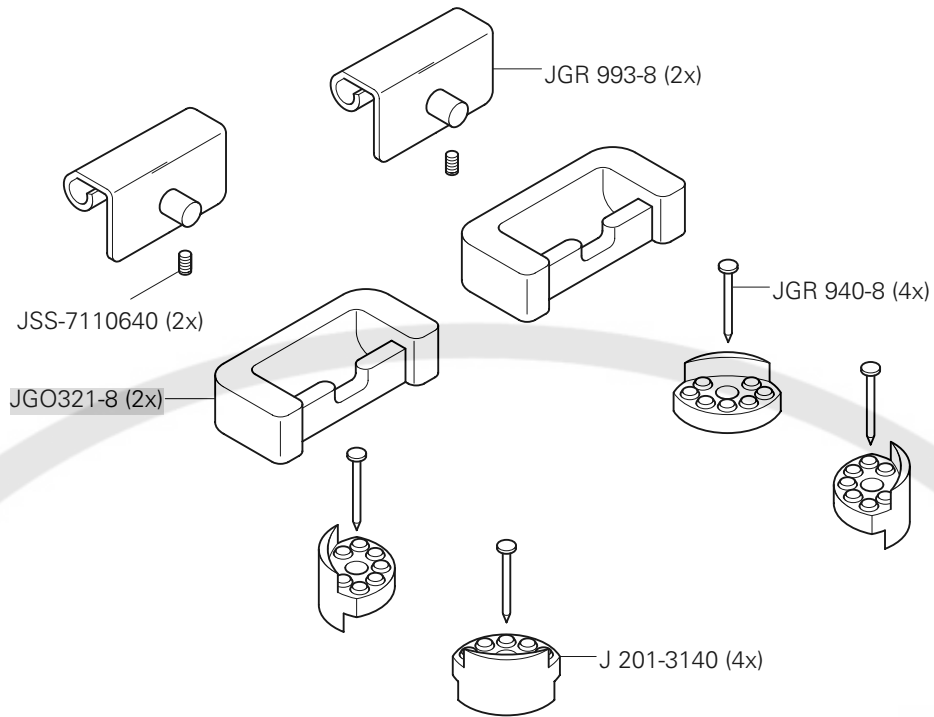

12

Keilriemen
V-belt
Correa trapezoidal
三角皮带

PFAFF 1122
PFAFF 1122-G

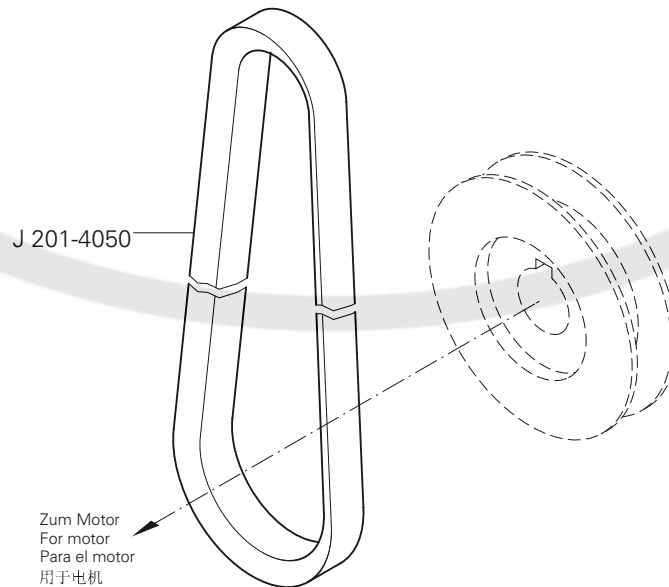

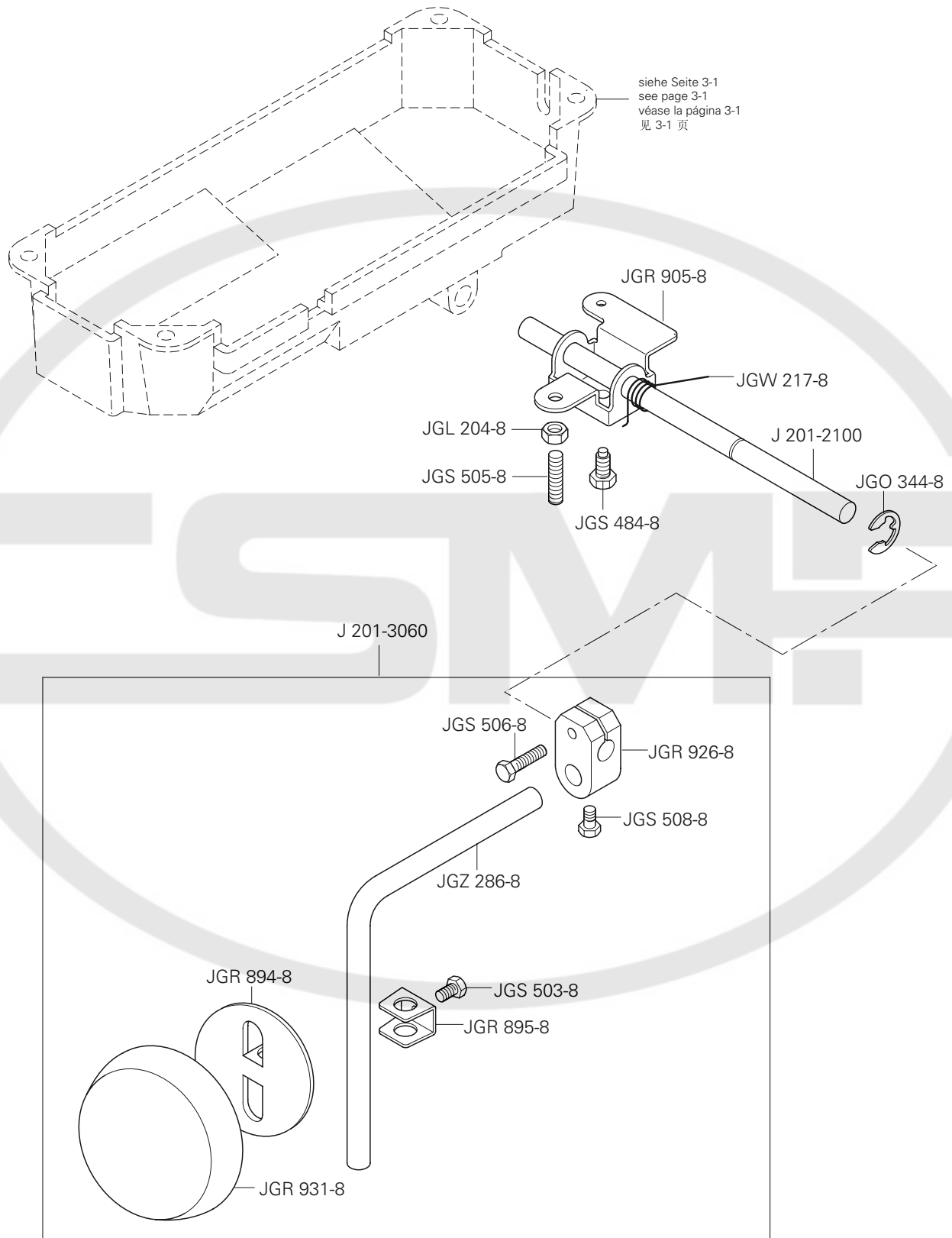

Öl Oil Aceite 油	Mittelpunkts-Viskosität bei: Mean viscosity at: Viscosidad media a: 中点粘度:		Dichte bei: Density of: Densidad a: 密度, 在:		Bestellnummer für Behälter mit: Part number for can with: Número de pedido para recipientes con: 订货号用于油箱, 带:		
	°C	mm ² /s	°C	g/cm ³ (g/ml)	1 Liter 1 Litre 1 Litro 1 升	5 Liter 5 Litre 5 Litros 5 升	10 Liter 10 Litre 10 Litros 10 升
28-011 201-05	40	10,0	15	0,847	91-027 975-91		

Fett Grease Grasa 脂	Penetration Penetration Penetración 贯入度	Tropfpunkt Drip-point Punto de goteo 贯入度	Bestellnummer für Behälter mit: Part number for can with: Número de pedido para recipientes con: 订货号用于油箱, 带:		
			mm/10	°C	0,25 kg 0,5 kg 1 kg

Reinigungsmittel Cleansing agent Limpiadores 清洁剂	Bestellnummer für Behälter mit: Part number for can with: Número de pedido para recipientes con: 订货号用于油箱, 带:
Isoprophyl-Alkohol 异丙醇	240 ml 95-665 735-91

No. 零件号	Seite Page Página 页号	No. 零件号	Seite Page Página 页号	No. 零件号	Seite Page Página 页号	No. 零件号	Seite Page Página 页号
11-108 168-15	7 - 1	71-770 000-63	9 - 2	J 201-0250	3 - 4	J 201-0930	3 - 5
11-108 174-15	9 - 4	91-027 975-91	13 - 1	J 201-0260	3 - 4	J 201-0940	3 - 5
11-130 179-25	9 - 2	91-027 976-91	13 - 1	J 201-0270	3 - 4	J 201-0950	3 - 7, 3 - 13
11-130 191-25	9 - 2	91-027 977-91	13 - 1	J 201-0280	3 - 4	J 201-0985	3 - 5
11-130 224-25	9 - 6	91-229 180-90	9 - 3	J 201-0290	3 - 4	J 201-1020	3 - 5
11-130 287-25	9 - 6	91-262 385-75/893	9 - 4	J 201-0300	3 - 4	J 201-1030	4 - 1
11-130 293-25	9 - 1	91-290 113-91	9 - 6	J 201-0315	3 - 4	J 201-1040	3 - 8
11-330 205-15	9 - 4	91-290 733-91	9 - 6	J 201-0455	3 - 10	J 201-1050	3 - 8, 4 - 1
11-335 902-15	7 - 1	91-291 458-91	9 - 6	J 201-0470	3 - 10	J 201-1060	3 - 8
11-460 163-15	9 - 3	95-665 735-91	13 - 1	J 201-0485	3 - 10	J 201-1070	3 - 8
11-460 250-15	9 - 3	99-136 854-55	9 - 6	J 201-0515	3 - 10	J 201-1080	3 - 11
11-462 403-55	9 - 4	99-137 196-05	9 - 4	J 201-0550	3 - 5	J 201-1090	3 - 14
12-305 114-25	9 - 2	J 101GS109	3 - 6	J 201-0560	3 - 3	J 201-1100	3 - 11, 3 - 14
12-305 144-25	9 - 6	J 101.21-5	7 - 1	J 201-0570	3 - 3, 3 - 13	J 201-1110	3 - 12
12-305 174-25	9 - 6	J 201-0010	3 - 6	J 201-0590	3 - 3	J 201-1140	3 - 12
12-499 150-45	9 - 4	J 201-0020	3 - 4	J 201-0600	3 - 3	J 201-1150	3 - 12
12-510 111-25	9 - 1, 9 - 2	J 201-0030	3 - 4	J 201-0630	3 - 3, 4 - 1	J 201-1160	3 - 11
12-510 140-45	9 - 6	J 201-0040	3 - 4, 5 - 1	J 201-0645	3 - 3	J 201-1180	3 - 11
12-510 141-45	9 - 6	J 201-00440	3 - 4	J 201-0660	4 - 1	J 201-1200	3 - 11
28-011 201-05	13 - 1	J 201-0050	3 - 1	J 201-0690	3 - 3	J 201-1210	3 - 12
71-370 001-08	9 - 3	J 201-0060	3 - 1	J 201-0700	3 - 3	J 201-1230	3 - 12
71-370 001-32	9 - 2	J 201-0070	3 - 3	J 201-0740	3 - 3	J 201-1245	3 - 11
71-370 002-92	9 - 3	J 201-0080	3 - 4	J 201-0750	3 - 3	J 201-1280	3 - 11
71-520 006-01	9 - 4	J 201-0110	3 - 1	J 201-0770	3 - 3	J 201-1300	3 - 12
71-520 006-02	9 - 3	J 201-0165	3 - 4	J 201-0780	3 - 3	J 201-1320	3 - 11
71-590 007-21	9 - 4	J 201-0170	3 - 4	J 201-0800	3 - 3	J 201-1335	3 - 11
71-590 007-71	9 - 1	J 201-0180	3 - 4	J 201-0820	3 - 5	J 201-1370	3 - 11
71-590 007-72	9 - 1	J 201-0190	3 - 4	J 201-0830	3 - 5	J 201-1385	3 - 12
71-590 007-77	9 - 1	J 201-0200	3 - 4	J 201-0840	3 - 5	J 201-1420	3 - 11
71-590 007-82	9 - 6	J 201-0210	3 - 4	J 201-0850	3 - 5	J 201-1435	3 - 14
71-590 007-99	9 - 1	J 201-0220	3 - 4	J 201-0870	3 - 5	J 201-1460	3 - 10
71-590 008-15	9 - 5	J 201-0230	3 - 4	J 201-0880	3 - 5	J 201-1475	3 - 14
71-590 008-14	9 - 5	J 201-0240	3 - 4	J 201-0900	3 - 5	J 201-1500	3 - 14

No. 零件号	Seite Page Página 页号	No. 零件号	Seite Page Página 页号	No. 零件号	Seite Page Página 页号	No. 零件号	Seite Page Página 页号
J 201-1520	3 - 12	J 201-2000	3 - 9	J 201-2570	3 - 13	J 203-0170	3 - 9, 4 - 2
J 201-1540	3 - 12	J 201-2020	3 - 9	J 201-2655	3 - 1	J 203-0180	3 - 11
J 201-1560	3 - 12	J 201-2030	3 - 2	J 201-2660	3 - 1	J 203-1190	3 - 11
J 201-1580	3 - 12	J 201-2040	3 - 2	J 201-2670	3 - 1	J 204-0620	3 - 3
J 201-1600	3 - 12	J 201-2050	3 - 2	J 201-2791	3 - 4	J 204-072	3 - 3
J 201-1610	3 - 10	J 201-2060	3 - 2	J 201-2793	3 - 4	J 204-6010	3 - 3
J 201-1620	3 - 10	J 201-2080	3 - 1	J 201-2810	3 - 11	J 205-0010	4 - 2
J 201-1630	3 - 10	J 201-2100	13 - 1	J 201-2920	3 - 5	J 205-0015	4 - 2
J 201-1640	3 - 14	J 201-2110	3 - 1	J 201-2950	4 - 1	J 205-0020	3 - 1
J 201-1650	3 - 14, 4 - 3	J 201-2125	3 - 1	J 201-2970	3 - 11	J 205-0030	4 - 2
J 201-1670	3 - 13	J 201-2195	3 - 2	J 201-3000	3 - 7	J 205-0035	4 - 2
J 201-1680	3 - 9	J 201-2220	3 - 8	J 201-3050	3 - 1	J 205-0040	4 - 2
J 201-1690	3 - 9	J 201-2230	3 - 8	J 201-3060	13 - 1	J 205-0075	4 - 2
J 201-1700	3 - 9	J 201-2280	3 - 2	J 201-3140	11 - 1	J 205-0080	4 - 2
J 201-1720	3 - 10	J 201-2290	3 - 8	J 201-3200	3 - 9	J 205-0085	4 - 1
J 201-1730	3 - 10	J 201-2310	3 - 2	J 201-3470	3 - 5	J 205-0105	4 - 1
J 201-1740	3 - 10	J 201-2320	3 - 7	J 201-3480	3 - 5	J 205-0115	4 - 1
J 201-1750	3 - 10	J 201-2330	3 - 7	J 201-3490	3 - 5	J 205-0125	4 - 1
J 201-1780	3 - 10	J 201-2350	3 - 7	J 201-3500	3 - 5, 3 - 6	J 205-0130	4 - 2
J 201-1795	3 - 14	J 201-2360	3 - 13	J 201-4000	10 - 1	J 205-0135	4 - 1
J 201-1820	3 - 14	J 201-2370	3 - 13	J 201-4050	11 - 1	J 205-0140	4 - 2
J 201-1835	3 - 14	J 201-2380	3 - 13	J 202-2970	3 - 11	J 205-0175	4 - 3
J 201-1850	3 - 14, 4 - 3	J 201-2400	3 - 13	J 203-0030	3 - 3	J 205-0185	4 - 2
J 201-1870	3 - 14	J 201-2410	3 - 13	J 203-0050	3 - 12	J 205-0190	4 - 2
J 201-1890	3 - 14	J 201-2420	3 - 13	J 203-0060	3 - 11	J 205-0200	4 - 2
J 201-1900	3 - 14	J 201-2430	3 - 12	J 203-0070	3 - 11	J 205-0210	4 - 2
J 201-1910	3 - 10	J 201-2440	3 - 13	J 203-0080	3 - 11	J 205-0220	4 - 2
J 201-1930	3 - 9	J 201-2450	3 - 13	J 203-0090	3 - 12	J 205-0230	4 - 2
J 201-1940	3 - 9	J 201-2470	3 - 3	J 203-0095	3 - 9, 4 - 2	J 205-0250	4 - 1
J 201-1950	3 - 9	J 201-2480	3 - 3	J 203-0100	3 - 11	J 205-0260	4 - 1
J 201-1965	3 - 9	J 201-2495	3 - 7	J 203-0140	3 - 14	J 205-0270	4 - 1
J 201-1970	3 - 9, 4 - 2	J 201-2540	3 - 13	J 203-0150	3 - 10	J 205-0280	4 - 1
J 201-1980	3 - 9	J 201-2560	3 - 13	J 203-0160	3 - 9	J 205-0290	4 - 1

No. 零件号	Seite Page Página 页号	No. 零件号	Seite Page Página 页号	No. 零件号	Seite Page Página 页号	No. 零件号	Seite Page Página 页号
J 205-0300	4 - 1	J 211-0290	8 - 1	J 211-0770	5 - 3	J 501BJ101	3 - 6
J 205-0310	4 - 1	J 211-0300	5 - 2	J 211-0780	5 - 4	J 501BJ103	3 - 6
J 205-0370	4 - 1	J 211-0310	5 - 2	J 211-0790	5 - 1	J 501GB107	3 - 6
J 205-0380	4 - 1	J 211-0340	5 - 1	J 211-0800	5 - 3	J 501GF118	3 - 6
J 205-0390	4 - 1	J 211-0350	5 - 1	J 211-0830	5 - 4	J 501GS101	3 - 6
J 205-0400	4 - 1	J 211-0360	5 - 3	J 211-0840	5 - 4	J 501GS104	3 - 1
J 205-0410	4 - 1	J 211-0380	5 - 3	J 211-0850	5 - 4	J 501GS108	3 - 6
J 205-0460	4 - 2	J 211-0390	8 - 1	J 211-0860	5 - 4	J 910/93-22	7 - 1
J 205-0470	4 - 2	J 211-0430	8 - 1	J 211-0870	5 - 4	JB1-0050603	4 - 2
J 205-0550	4 - 2	J 211-0440	8 - 1	J 211-0940	5 - 2	JB1-0250303	4 - 1
J 205-0590	3 - 3	J 211-0450	8 - 1	J 211-1110	8 - 1	JB1-02805	3 - 14
J 205-2430	4 - 1	J 211-0460	8 - 1	J 211-1120	8 - 1	JB1-0310903	4 - 1
J 205-2970	4 - 3	J 211-0480	6 - 1	J 211-1140	5 - 4, 6 - 1	JB1-0325025	4 - 1
J 208-0020	4 - 3	J 211-0490	6 - 1	J 211-1280	6 - 1	JB1-0370503	4 - 1
J 211-0020	8 - 1	J 211-0500	6 - 1	J 211-1290	6 - 1	JB1-0731003	4 - 2
J 211-0100	9 - 2	J 211-0510	6 - 1	J 211-1310	6 - 1	JB1-0740803	4 - 2
J 211-0120	5 - 3	J 211-0520	6 - 1	J 211-1330	6 - 1	JB1-07614	3 - 2
J 211-0125	5 - 1	J 211-0550	6 - 1	J 211-1340	6 - 1	JB1-0810703	4 - 2
J 211-0140	5 - 3	J 211-0560	6 - 1	J 211-1360	6 - 1	JB1-09010	3 - 13
J 211-0145	8 - 1	J 211-0580	6 - 1	J 211-1370	6 - 1	JB1-10412	5 - 3
J 211-0155	6 - 1	J 211-0620	6 - 1	J 211-1380	5 - 1	JB2-03505	3 - 2, 5 - 1
J 211-0160	5 - 2	J 211-0640	5 - 4	J 211-1390	9 - 2	JB2-05408	5 - 3
J 211-0165	6 - 1	J 211-0650	5 - 4, 6 - 1	J 211-1410	9 - 2	JB2-08010	3 - 9
J 211-0190	5 - 1	J 211-0670	5 - 2	J 211-1420	9 - 2	JB4-12404	3 - 4
J 211-0200	5 - 1	J 211-0680	5 - 2	J 211-1430	9 - 2	JB4-17713	3 - 4
J 211-0205	8 - 1	J 211-0690	5 - 2	J 211-1440	8 - 1	JB5-1040501	3 - 4
J 211-0210	5 - 1	J 211-0700	5 - 3	J 211-1450	8 - 1	JB5-1040502	3 - 4
J 211-0230	5 - 1	J 211-0710	5 - 3	J 211-2280	5 - 1	JB5-200-12	3 - 9
J 211-0245	5 - 3	J 211-0720	5 - 3	J 211-2303	3 - 2	JBP-4828090	3 - 7
J 211-0250	5 - 1	J 211-0730	5 - 3	J 213-0940	5 - 2	JBP-4828135	3 - 13
J 211-0255	5 - 1	J 211-0740	5 - 3	J 215-0020	5 - 2	JBP-4828160	3 - 7
J 211-0265	5 - 4	J 211-0750	5 - 3	J 217GD102	8 - 1	JBP-4828180	3 - 13
J 211-0275	5 - 3	J 211-0760	5 - 3	J 221-0020	5 - 2	JBP-4828190	3 - 7

No. 零件号	Seite Page Página 页号	No. 零件号	Seite Page Página 页号	No. 零件号	Seite Page Página 页号	No. 零件号	Seite Page Página 页号
JBP-4828240	3 - 13	JGO 344-8	13 - 1	JMZ-30035	3 - 13	JSD-8160728	3 - 13
JBP-4828280	3 - 7	JGR 894-8	13 - 1	JMZ-301504	3 - 3	JSD-8200624	3 - 8
JBP-4828300	3 - 13	JGR 895-8	13 - 1	JMZ-302108	3 - 13	JSL-6060632	3 - 4
JBP-4828390	3 - 7	JGR 899-8	3 - 1	JMZ-311505	3 - 3	JSS-1120532	3 - 12
JBP-4828600	3 - 7	JGR 905-8	13 - 1	JMZ-330807	3 - 4	JSS-1120832	5 - 3
JBP-8050165	3 - 7	JGR 923-8	3 - 2	JMZ-400803	3 - 12	JSS-1121-32	3 - 12
JCQ-03220	4 - 1	JGR 926-8	13 - 1	JMZ-50011	3 - 14	JSS-1160340	3 - 11
JCQ-15200	3 - 3	JGR 931-8	13 - 1	JMZ-95014	3 - 1, 3 - 14	JSS-1161740	3 - 12
JCQ-15430	3 - 13	JGR 940-8	11 - 1	JMZ-70030	3 - 7	JSS-2080640	3 - 4
JCQ-15530	3 - 13	JGR 993-8	11 - 1	JNS-8080240	3 - 10, 5 - 1	JSS-2130432	3 - 10
JCQ-30030	3 - 3	JGR-976-8	3 - 9, 4 - 2	JNS-8090340	3 - 2, 5 - 3	JSS-2160440	3 - 5, 3 - 10
JCQ-30710	3 - 8	JGS-451-8	3 - 2	JNS-81230	3 - 12	JSS-2160540	3 - 5, 3 - 11, 5 - 2
JCQ-40025	3 - 3, 3 - 7	JGS 484-8	13 - 1	JNS-8160328	3 - 2	JSS-2161728	3 - 2
JCQ-40035	3 - 7	JGS 494-8	3 - 9, 4 - 2	JNS-81628	3 - 6	JSS-30602556	4 - 1
JCQ-40040	3 - 3, 3 - 7, 3 - 11, 3 - 14	JGS 503-8	13 - 1	JNS-8200524	3 - 8	JSS-30806340	4 - 1
JCQ-40070	3 - 7, 3 - 12	JGS 505-8	13 - 1	JNS-88128	5 - 4	JSS-3090640	3 - 10
JCQ-40072	3 - 5	JGS 506-8	13 - 1	JPS-0150581	4 - 1	JSS-3090840	3 - 4
JCQ-40110	3 - 14	JGS 508-8	13 - 1	JPS-02001781	4 - 1	JSS-3121032	3 - 7, 3 - 9, 3 - 12, 4 - 2
JCQ-40138	3 - 3	JGS513-8	3 - 2	JPS-0201581	4 - 1	JSS-3161820	3 - 8
JCQ-40250	3 - 12, 3 - 14	JGW-216-8	3 - 9	JRC-04006	3 - 1, 3 - 12	JSS-3161828	3 - 10
JCQ-40350	3 - 14	JGW 217-8	13 - 1	JRC-05808	3 - 14	JSS-3162020	3 - 8, 4 - 1
JCQ-40650	3 - 7	JGX 235-8	3 - 9	JRC-07912	5 - 2	JSS-4080440	3 - 14
JGB 308-77	4 - 2	JGZ 286-8	13 - 1	JRC-08010	3 - 9	JSS-4080540	4 - 1
JGB896-4	7 - 1	JGZ483-8	3 - 2	JRD-10810	3 - 11	JSS-4081040	3 - 10, 5 - 1
JGBS 204-8	3 - 1	JL.4-5	7 - 1	JRO-03035	3 - 7	JSS-4090540	3 - 1, 3 - 3, 3 - 4, 3 - 7, 3 - 8, 3 - 12, 3 - 14, 4 - 1, 4 - 2, 5 - 1, 5 - 4
JGB/T808	7 - 1	JL.8-4	7 - 1	JSD-02110703	4 - 2	JSS-4090640	3 - 13
JGL202-8	3 - 2	JL.1-29	7 - 1	JSD-30602556	4 - 1	JSS-4090740	3 - 9
JGL 204-8	13 - 1	JMZ-06055	4 - 1	JSD-6090140	3 - 4	JSS-4090840	3 - 2, 3 - 3, 3 - 15, 4 - 1, 5 - 3
JGL 6	5 - 1	JMZ-10060	3 - 12	JSD-6090540	3 - 2	JSS-4110840	3 - 1, 3 - 4, 4 - 1, 5 - 1
JGO 307-8	3 - 2	JMZ-201202	3 - 10	JSD-6110540	4 - 2	JSS-4111040	3 - 1, 3 - 14, 4 - 2, 4 - 3
JGO 316-8	3 - 9, 4 - 2	JMZ-20143	4 - 1	JSD-6150828	3 - 9		
JGO 321-8	11 - 1	JMZ-2390	3 - 13	JSD-6160628	3 - 8		
JGO 332-8	3 - 2	JMZ-241509	3 - 7	JSD-7120340	3 - 8		

No. 零件号	Seite Page Página 页号	No. 零件号	Seite Page Página 页号	No. 零件号	Seite Page Página 页号	No. 零件号	Seite Page Página 页号
JSS-4111240	3 - 10, 5 - 3	JSS-70903540	4 - 2	JWP-07310	3 - 10		
JSS-4120632	3 - 9, 3 - 13, 5 - 1	JSS-7090840	3 - 12, 5 - 1, 5 - 2	JWP-10510	3 - 9, 5 - 3		
JSS-4121232	3 - 3, 5 - 4, 6 - 1, 9 - 2	JSS-7110440	3 - 2, 5 - 4, 6 - 1, 8 - 1	JWP-10680	5 - 4		
JSS-4121432	4 - 2	JSS-7110640	3 - 5, 3 - 12, 11 - 1	JWP-15008	3 - 7		
JSS-4122032	3 - 1	JSS-7150628	3 - 9, 3 - 10	JZT110-1	7 - 1		
JSS-4151428	3 - 10	JSS-7150828	3 - 9	JZT110-1-2	7 - 1		
JSS-4162528	3 - 12	JSS-7151040	3 - 14	JZT110-2	7 - 1		
JSS-5060210	3 - 10	JSS-7160740	5 - 3	JZT110-3	7 - 1		
JSS-5060356	3 - 3, 4 - 1	JSS-7161028	3 - 2, 3 - 3, 3 - 5, 3 - 10, 3 - 14	JZT110-4	7 - 1		
JSS-5081244	6 - 1	JSS-7161040	3 - 5, 3 - 14, 5 - 3	JZT110-5	7 - 1		
JSS-5090440	3 - 4, 3 - 11, 4 - 2, 5 - 1	JSS-7161240	3 - 5, 3 - 14	JZT110-6	7 - 1		
JSS-5110640	3 - 10	JSS-716240	3 - 14	JZT110-7	7 - 1		
JSS-5111640	3 - 5	JSS-7201028	4 - 1	JZT110-8	7 - 1		
JSS-511640	9 - 2	JSS-8090840	3 - 12	JZT110-9	7 - 1		
JSS-5120828	6 - 1	JSS-8151028	3 - 2	JZT110-11	7 - 1		
JSS-5121032	5 - 4	JSS-8251033	5 - 2	JZT110-13	7 - 1		
JSS-5161128	5 - 4	JSS-8251034	5 - 2	JZT110-14	7 - 1		
JSS-5161428	6 - 1, 8 - 1	JTA-0120601	3 - 1				
JSS-6080344	5 - 2	JTA-0120602	3 - 1, 3 - 7				
JSS-60805840	4 - 1	JTA-0120603	3 - 7				
JSS-6110640	3 - 10, 5 - 3, 5 - 4	JWP-04010	3 - 13				
JSS-6120732	8 - 1	JWP-04705	3 - 12				
JSS-6150628	5 - 3	JWP-04708	3 - 5, 9 - 2				
JSS-6151228	3 - 12	JWP-04710	3 - 1				
JSS-6151328	3 - 5	JWP-05008	3 - 9, 3 - 12				
JSS-6160540	3 - 14	JWP-05010	9 - 2				
JSS-6161828	8 - 1	JWP-05015	5 - 3, 5 - 4				
JSS-6180828	3 - 5	JWP-05108	6 - 1				
JSS-6181828	3 - 5	JWP-05510	3 - 1				
JSS-7080444	6 - 1	JWP-06506	3 - 10				
JSS-7080744	3 - 10	JWP-06510	8 - 1				
JSS-70804040	4 - 1	JWP-06520	8 - 1				
JSS-70805840	4 - 1	JWP-07034	3 - 12				

PFAFF

1122

1122-G

Unterklassen-Ausstattung

Subclass parts

Composición de las subclases

子机型-设备

1122-720/02

1122-G-720/02

-6/01

Für allgemeine Näharbeiten.
Standardform des Teilesatzes

For ordinary sewing operations.
Standard part set.

Para trabajos de costura en general.
Juego de piezas estándar.

适用于一般性缝纫工作。
套件的标准型式。

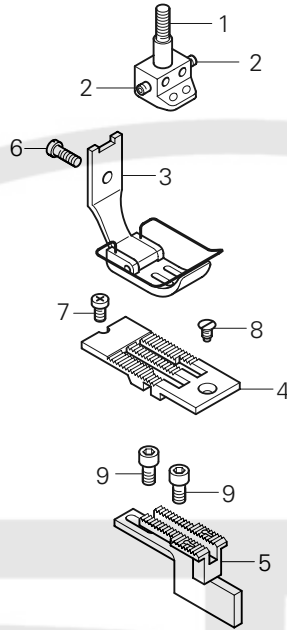

Pos.-Nr. Item No. 序号	Ausführung Model Typo 款式	Stichlänge Stitch length Largo de puntada 针距	Nadelabstand Needle gauge Distancia entre agujas 机针间距	Teile-Nr. Part No. 零件号
1 - 5	A♦	4,0	3,2	91-202 510-93/001
	A♦	4,0	4,8	91-202 510-93/004
	A♦	4,0	6,4	91-202 510-93/007
	B♦	4,0	3,2	91-202 510-93/002
	B♦	4,0	4,8	91-202 510-93/005
	B♦	4,0	6,4	91-202 510-93/009
	C♦	5,0	3,2	91-202 510-93/003
	C♦	5,0	4,8	91-202 510-93/006
	C♦	5,0	6,4	91-202 510-93/011
1 - 2			3,2	J 158 794-101
			4,8	J 158 791-101
			6,4	J 158 792-101
2				J SS-6090440
3			3,2	J S36 544-001
			4,8	J S36 546-001
			6,4	J S36 548-001
4	A♦;B♦	4,0	3,2	J 114 950-001
	A♦;B♦	4,0	4,8	J 112 603-001

Pos.-Nr. Item No. 序号	Ausführung Model Typo 款式	Stichlänge Stitch length Largo de puntada 针距	Nadelabstand Needle gauge Distancia entre agujas 机针间距	Teile-Nr. Part No. 零件号
	A♦;B♦	4,0	6,4	J 112 604-001
	C♦	5,0	3,2	J 117 369-001
	C♦	5,0	4,8	J 117 133-001
	C♦	5,0	6,4	J 117 367-001
5	A♦	4,0	3,2	J S07 880-001
	A♦	4,0	4,8	J S07 878-001
	A♦	4,0	6,4	J S07 879-001
	B♦	4,0	3,2	J 114 951-001
	B♦	4,0	4,8	J 112 659-001
	B♦	4,0	6,4	J 112 660-001
	C♦	5,0	3,2	J 158 430-001
	C♦	5,0	4,8	J S13 588-001
	C♦	5,0	6,4	J 153 882-001
6				J SD-6090540
7				J SS-6110640
8				J SS-5110640
9				J SS-7080774



-6/01-900/93

Für allgemeine Näharbeiten.
Standardform des Teilesatzes

For ordinary sewing operations.
Standard part set.

Para trabajos de costura en general.
Juego de piezas estándar.

适用于一般性缝纫工作。
套件的标准型式。

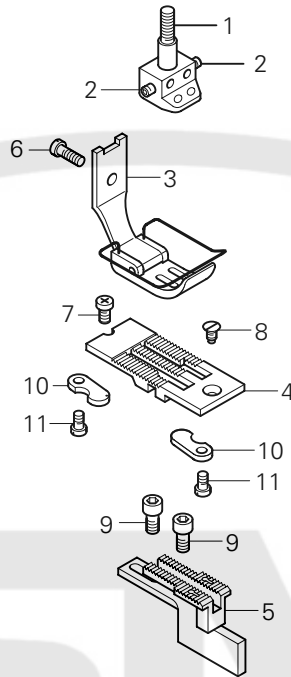

Pos.-Nr. Item No. 序号	Ausführung Model Typo 款式	Stichlänge Stitch length Largo de puntada 针距	Nadelabstand Needle gauge Distancia entre agujas 机针间距	Teile-Nr. Part No. 零件号	Pos.-Nr. Item No. 序号	Ausführung Model Typo 款式	Stichlänge Stitch length Largo de puntada 针距	Nadelabstand Needle gauge Distancia entre agujas 机针间距	Teile-Nr. Part No. 零件号
1 - 5	A♦;B♦	4,0	3,2	91-202 513-93/001	5	A♦;B♦	4,0	6,4	J 158 783-001
	A♦;B♦	4,0	4,8	91-202 513-93/003		C♦	5,0	3,2	J 155 722-001
	A♦;B♦	4,0	6,4	91-202 513-93/006		C♦	5,0	4,8	J 155 851-001
	C♦	5,0	3,2	91-202 513-93/002		C♦	5,0	6,4	J 155 853-001
	C♦	5,0	4,8	91-202 513-93/004		A♦;B♦	4,0	3,2	J 148 698-001
	C♦	5,0	6,4	91-202 513-93/007		A♦;B♦	4,0	4,8	J 148 702-001
1 - 2			3,2	J 158 794-101	A♦;B♦	4,0	6,4	J 148 704-001	
			4,8	J 158 791-101	C♦	5,0	3,2	J 148 699-001	
			6,4	J 158 792-101	C♦	5,0	4,8	J 148 703-001	
2			J SS-6090440	C♦	5,0	6,4	J 158 756-001		
3	A♦;B♦	4,0	3,2	J S36 550-001	6			J SD-6090540	
	A♦;B♦	4,0	4,8	J S36 554-001	7			J SS-6110640	
	A♦;B♦	4,0	6,4	J S36 558-001	8			J SS-5110640	
	C♦	5,0	3,2	J S36 552-001	9			J SS-7080774	
	C♦	5,0	4,8	J S36 556-001	10			J S07 527-001	
4	A♦;B♦	4,0	3,2	J 159 400-001	11			J 148 539-101	
	A♦;B♦	4,0	4,8	J 158 784-001					

-6/01-G

Für allgemeine Näharbeiten.
Standardform des Teilesatzes

For ordinary sewing operations.
Standard part set.

Para trabajos de costura en general.
Juego de piezas estándar.

适用于一般性缝纫工作。
套件的标准型式。

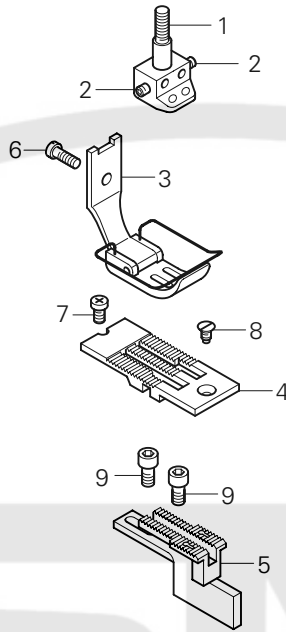

Pos.-Nr. Item No. 序号	Ausführung Model Typo 款式	Stichlänge Stitch length Largo de puntada 针距	Nadelabstand Needle gauge Distancia entre agujas 机针间距	Teile-Nr. Part No. 零件号
1 - 5	B♦	7,0	3,2	91-202 512-93/001
	B♦	7,0	4,8	91-202 512-93/003
	B♦	7,0	6,4	91-202 512-93/006
	C♦	7,0	3,2	91-202 512-93/002
	C♦	7,0	4,8	91-202 512-93/004
	C♦	7,0	6,4	91-202 512-93/007
	1 - 2			3,2
			4,8	J 158 791-101
			6,4	J 158 792-101
2				J SS-6090440
3			3,2	J S36 562-001
			4,8	J S36 564-001
			6,4	J S36 566-001

Pos.-Nr. Item No. 序号	Ausführung Model Typo 款式	Stichlänge Stitch length Largo de puntada 针距	Nadelabstand Needle gauge Distancia entre agujas 机针间距	Teile-Nr. Part No. 零件号
4			3,2	J 117 369-001
			4,8	J 117 133-001
			6,4	J 117 367-001
5	B♦	7,0	3,2	J 114 951-001
	B♦	7,0	4,8	J 112 659-001
	B♦	7,0	6,4	J 112 660-001
	C♦	7,0	3,2	J 158 430-001
6			4,8	J S13 588-001
			6,4	J 153 882-001
				J SD-6090540
7				J SS-6110640
8				J SS-5110640
9				J SS-7080774



-6/01-G-900/93

Für allgemeine Näharbeiten.
Standardform des Teilesatzes

For ordinary sewing operations.
Standard part set.

Para trabajos de costura en general.
Juego de piezas estándar.

适用于一般性缝纫工作。
套件的标准型式。

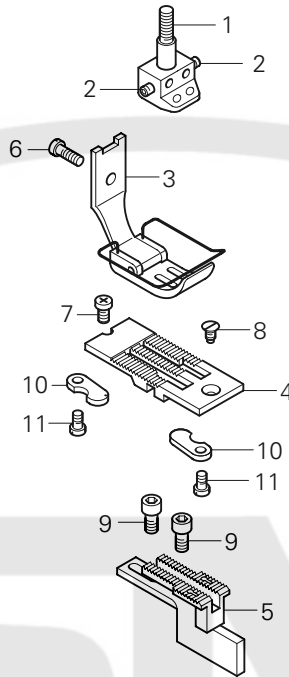

Pos.-Nr. Item No. 序号	Ausführung Model Typo 款式	Stichlänge Stitch length Largo de puntada 针距	Nadelabstand Needle gauge Distancia entre agujas 机针间距	Teile-Nr. Part No. 零件号	Pos.-Nr. Item No. 序号	Ausführung Model Typo 款式	Stichlänge Stitch length Largo de puntada 针距	Nadelabstand Needle gauge Distancia entre agujas 机针间距	Teile-Nr. Part No. 零件号
1 - 5	A♦;B♦	7,0	3,2	91-202 515-93/001	5	A♦;B♦	7,0	3,2	J 148 698-001
	A♦;B♦	7,0	4,8	91-202 515-93/003		A♦;B♦	7,0	4,8	J 148 702-001
	A♦;B♦	7,0	6,4	91-202 515-93/006		A♦;B♦	7,0	6,4	J 148 704-001
	C♦	7,0	3,2	91-202 515-93/002		C♦	7,0	3,2	J 148 699-001
	C♦	7,0	4,8	91-202 515-93/004		C♦	7,0	4,8	J 148 703-001
	C♦	7,0	6,4	91-202 515-93/007		C♦	7,0	6,4	J 148 705-001
	C♦	7,0	6,4	91-202 515-93/007					
1 - 2			3,2	J 158 794-101	6				J SD-6090540
			4,8	J 158 791-101	7				J SS-6110640
			6,4	J 158 792-101	8				J SS-5110640
2			J SS-6090440	9				J SS-7080774	
3			3,2	J S36 562-001	10				J S07 527-001
			4,8	J S36 564-001	11				J 148 539-101
			6,4	J S36 566-001					
4			J 155 722-001						

-6/01-720/02

Für allgemeine Näharbeiten.
Standardform des Teilesatzes.

For ordinary sewing operations.
Standard part set.

Para trabajos de costura en general.
Juego de piezas estándar.

适用于一般性缝纫工作。
套件的标准型式。

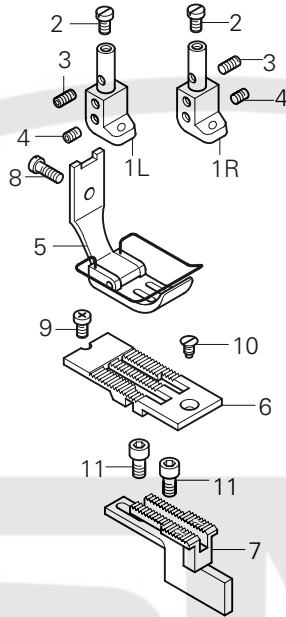

Pos.-Nr. Item No. 序号	Ausführung Model Typo 款式	Stichlänge Stitch length Largo de puntada 针距	Nadelabstand Needle gauge Distancia entre agujas 机针间距	Teile-Nr. Part No. 零件号
1 - 7	A♦	5,0	3,2	91-202 511-93/001
	A♦	5,0	4,8	91-202 511-93/004
	A♦	5,0	6,4	91-202 511-93/007
	B♦	5,0	3,2	91-202 511-93/002
	B♦	5,0	4,8	91-202 511-93/005
	B♦	5,0	6,4	91-202 511-93/009
	C♦	5,0	3,2	91-202 511-93/003
	C♦	5,0	4,8	91-202 511-93/006
	C♦	5,0	6,4	91-202 511-93/010
1L - 4			3,2	J S15 711-001
			4,8	J S15 723-001
			6,4	J S15 735-001
1R - 4			3,2	J S15 712-001
			4,8	J S15 724-001
			6,4	J S15 736-001
2			J SS-6085840	
3			J 70805840	
4			J 70804040	

Pos.-Nr. Item No. 序号	Ausführung Model Typo 款式	Stichlänge Stitch length Largo de puntada 针距	Nadelabstand Needle gauge Distancia entre agujas 机针间距	Teile-Nr. Part No. 零件号
5			3,2	J S36 544-001
			4,8	J S36 546-001
			6,4	J S36 548-001
6			3,2	J 117 369-001
			4,8	J 117 133-001
			6,4	J 117 367-001
7	A♦	5,0	3,2	J S07 880-001
	A♦	5,0	4,8	J S07 878-001
	A♦	5,0	6,4	J S07 879-001
	B♦	5,0	3,2	J 114 951-001
	B♦	5,0	4,8	J 112 659-001
	B♦	5,0	6,4	J 112 660-001
	C♦	5,0	3,2	J 158 430-001
C♦	5,0	4,8	J S13 588-001	
C♦	5,0	6,4	J 153 882-001	
8				J SD-6090540
9				J SS-6110640
10				J SS-5110640
11				J SS-7080774



-6/01-720/02-900/53

Für allgemeine Näharbeiten.
Standardform des Teilesatzes

For ordinary sewing operations.
Standard part set.

Para trabajos de costura en general.
Juego de piezas estándar.

适用于一般性缝纫工作。
套件的标准型式。

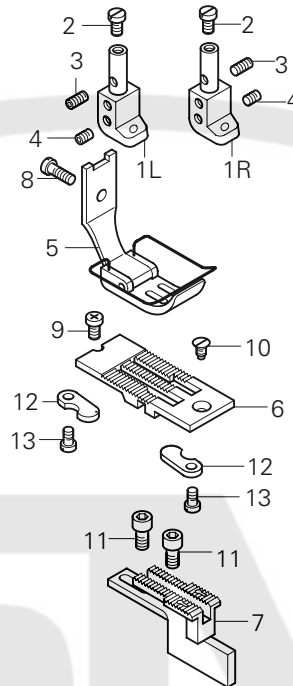

Pos.-Nr. Item No. 序号	Ausführung Model 款式	Stichlänge Stitch length Largo de puntada 针距	Nadelabstand Needle gauge Distancia entre agujas 机针间距	Teile-Nr. Part No. 零件号	Pos.-Nr. Item No. 序号	Ausführung Model 款式	Stichlänge Stitch length Largo de puntada 针距	Nadelabstand Needle gauge Distancia entre agujas 机针间距	Teile-Nr. Part No. 零件号
1 - 7	A♦;B♦	5,0	3,2	91-202 514-93/001	6	C♦	5,0	3,2	J S36 552-001
	A♦;B♦	5,0	4,8	91-202 514-93/003		C♦	5,0	4,8	J S36 556-001
	A♦;B♦	5,0	6,4	91-202 514-93/006		C♦	5,0	6,4	J S36 660-001
	C♦	5,0	3,2	91-202 514-93/002	7	A♦;B♦	5,0	3,2	J 148 698-001
	C♦	5,0	4,8	91-202 514-93/004		A♦;B♦	5,0	4,8	J 148 702-001
	C♦	5,0	6,4	91-202 514-93/007		A♦;B♦	5,0	6,4	J 148 704-001
1L - 4			3,2	J S15 711-001	C♦	5,0	3,2	J 148 699-001	
			4,8	J S15 723-001	C♦	5,0	4,8	J 148 703-001	
			6,4	J S15 735-001	C♦	5,0	6,4	J 148 705-001	
1R - 4			3,2	J S15 712-001	8			J SD-6090540	
			4,8	J S15 724-001	9			J SS-6110640	
			6,4	J S15 736-001	10			J SS-5110640	
2				J SS-6085840	11			J SS-7080774	
3				J 70805840	12			J S07 527-001	
4				J 70804040	13			J 148 539-101	
5	A♦;B♦	5,0	3,2	J S36 550-001					
	A♦;B♦	5,0	4,8	J S36 554-001					
	A♦;B♦	5,0	6,4	J S36 558-001					

-6/01-G-720/02

Für allgemeine Näharbeiten.
Standardform des Teilesatzes.

For ordinary sewing operations.
Standard part set.

Para trabajos de costura en general.
Juego de piezas estándar.

适用于一般性缝纫工作。
套件的标准型式。

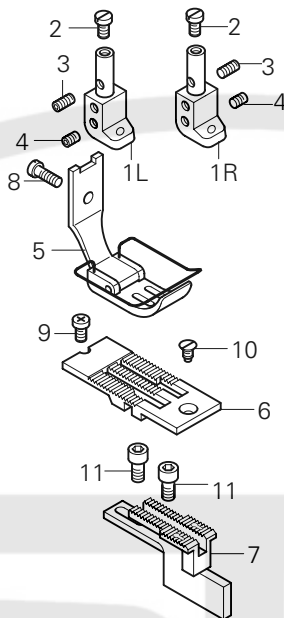

Pos.-Nr. Item No. 序号	Ausführung Model Typo 款式	Stichlänge Stitch length Largo de puntada 针距	Nadelabstand Needle gauge Distancia entre agujas 机针间距	Teile-Nr. Part No. 零件号
1 - 7	B♦	7,0	3,2	91-202 512-93/008
	B♦	7,0	4,8	91-202 512-93/010
	B♦	7,0	6,4	91-202 512-93/013
	C♦	7,0	3,2	91-202 512-93/009
	C♦	7,0	4,8	91-202 512-93/011
	C♦	7,0	6,4	91-202 512-93/014
1L - 4			3,2	J S15 711-001
			4,8	J S15 723-001
			6,4	J S15 735-001
1R - 4			3,2	J S15 712-001
			4,8	J S15 724-001
			6,4	J S15 736-001
2			J SS-6085840	
3			J 70805840	
4			J 70804040	
5			J S36 562-001	

Pos.-Nr. Item No. 序号	Ausführung Model Typo 款式	Stichlänge Stitch length Largo de puntada 针距	Nadelabstand Needle gauge Distancia entre agujas 机针间距	Teile-Nr. Part No. 零件号
			4,8	J S36 564-001
			6,4	J S36 566-001
	6		3,2	J 117 369-001
			4,8	J 117 133-001
			6,4	J 117 367-001
	7	B♦	7,0	J 114 951-001
		B♦	7,0	J 112 659-001
		B♦	7,0	J 112 660-001
			3,2	J 158 430-001
			4,8	J S13 588-001
			6,4	J 153 882-001
8			J SD-6090540	
9			J SS-6110640	
10			J SS-5110640	
11			J SS-7080774	



-6/01-G-720/02-900/93

Für allgemeine Näharbeiten.
Standardform des Teilesatzes

For ordinary sewing operations.
Standard part set.

Para trabajos de costura en general.
Juego de piezas estándar.

适用于一般性缝纫工作。
套件的标准型式。

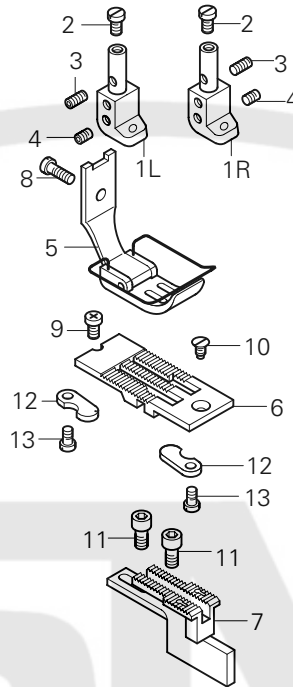

Pos.-Nr. Item No. 序号	Ausführung Model Typo 款式	Stichlänge Stitch length Largo de puntada 针距	Nadelabstand Needle gauge Distancia entre agujas 机针间距	Teile-Nr. Part No. 零件号
1 - 7	A♦;B♦	7,0	3,2	91-202 515-93/008
	A♦;B♦	7,0	4,8	91-202 515-93/010
	A♦;B♦	7,0	6,4	91-202 515-93/013
	C♦	7,0	3,2	91-202 515-93/009
	C♦	7,0	4,8	91-202 515-93/011
	C♦	7,0	6,4	91-202 515-93/014
1L - 4			3,2	J S15 711-001
			4,8	J S15 723-001
			6,4	J S15 735-001
1R - 4			3,2	J S15 712-001
			4,8	J S15 724-001
			6,4	J S15 736-001
2			J SS-6085840	
3			J 70805840	
4			J 70804040	
5			3,2	J S36 562-001
			4,8	J S36 564-001

Pos.-Nr. Item No. 序号	Ausführung Model Typo 款式	Stichlänge Stitch length Largo de puntada 针距	Nadelabstand Needle gauge Distancia entre agujas 机针间距	Teile-Nr. Part No. 零件号
6			6,4	J S36 566-001
			3,2	J 155 722-001
			4,8	J 155 851-001
			6,4	J 155 853-001
7	A♦;B♦	7,0	3,2	J 148 698-001
	A♦;B♦	7,0	4,8	J 148 702-001
	A♦;B♦	7,0	6,4	J 148 704-001
	C♦	7,0	3,2	J 148 699-001
	C♦	7,0	4,8	J 148 703-001
	C♦	7,0	6,4	J 148 705-001
8				J SD-6090540
9				J SS-6110640
10				J SS-5110640
11				J SS-7080774
12				J S07 527-001
13				J 148 539-101

PFAFF



PFAFF Industrie Maschinen AG

Postfach 3020
D-67653 Kaiserslautern

Königstr. 154
D-67655 Kaiserslautern

Telefon: (0631) 200-0
Telefax: (0631) 17202
E-Mail: info@pfaff-industrial.com