

Pfaff 346 H3

Pfaff 656 01

Pfaff 646 706 47



CSMP

PFAFF[®]

346 -H3-656/01
646 -706/47-656/01









Bestandteileliste

List of spare parts

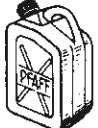
Liste de pièces détachées

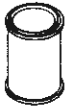
Lista de piezas de repuesto

Öl Oil Huile Aceite	Viskosität bei: Viscosity of: Viscosité à: Viscosidad a:		Dichte bei: Density of: Densité à: Densidad a:		Bestellnummer für Behälter mit: Ordering number for can containing: Numéro de commande pour récipients avec: Número de pedido para recipientes con:			
	°C	mm ² /s	°C	g/cm ³ (g/ml)	Liter Litre Litros			
280-1-120 144	50	15,0	15	0,865	0,09	91-129 138-91		
					0,25		91-129 916-91	
					1		91-129 917-91	
					5			91-129 919-91
					10			91-129 920-91
280-1-120 122	20	41,5	15	0,858	0,09	91-129 569-91		
					0,25			
					1		91-129 452-91	
					5			91-129 456-91
					10			91-129 541-91
					0,09			
					0,25			
					1			
					5			
					10			
Fett Grease Graisse Grasa	Penetration Penetration Pénétration Penetración		Tropfpunkt Drip-point Point de suintement Punto de goteo		Bestellnummer für Behälter mit: Ordering number for can containing: Numéro de commande pour récipients avec: Número de pedido para recipientes con:			
	mm/10		°C		kg			
280-1-120 205					0,5			
					1			280-1-120 205
280-1-120 247	220 - 250		185		0,5			
					1		280-1-120 247	
					0,5			
					1			

- B** Version B
- C** Version C
- 4,5** Longueur du point 4,5 mm
- N** Longueur du point 6,0 mm
- 3** Pièce collée
- 4** Préciser la version à la commande.
- 5** Joindre échantillons de couture.
- 6** Préciser la grosseur de l'aiguille et la forme de la pointe à la commande.
- 10** Écartement des aiguilles.
- 10/1** La forme est fonction de l'écartement des aiguilles (par ex. le nombre des rangées de dents de la griffe)
- 10/2** Écartement des aiguilles à préciser à la commande.
- 27/5** Chiffre entre parenthèses = longueur en mm.
- 30** Ancienne version, à commander à nouveau pour échange.
- 30/2** Ancienne version, remplacée par n° 11-210 168-15.
- 30/3** Ancienne version, remplacée par nouvelle nos 91-140 834-91; 91-140 133-92 et 91-140 803-05.
- 32** Aucune garantie ne pourra être assurée quant à la précision d'ajustage de cette pièce avec la pièce correspondante; il est indiqué de commander un mécanisme complet.
- 40/1** Remplir de 280-1-120 144; n° de commande, voir "Tableau des lubrifiants"
- 40/3** Graisser avec de la graisse 280-1-120 247, n° de commande, voir "Tableau des lubrifiants"
- 40/8** Imbiber d'huile blanche, 280-1-120 122, n° de commande, voir "Tableau des lubrifiants"
- 40/13** Graisser avec de la graisse 280-1-120205, n° de commande, voir "Tableau des lubrifiants"
- 80/4** Pour tuyau d'un diamètre intérieur de 4 mm.
- 80/6** Pour tuyau d'un diamètre intérieur de 6 mm.
- 90/5** Pour raccorder le synchronisateur Quick B/T sur la boîte de contrôle avec prise à 4 pôles.
- 90/6** Pour raccorder le synchronisateur Quick B/K sur la boîte de contrôle avec prise à 7 pôles.
- 90/9** Pour moteurs avec numéro de modèle à 8 chiffres.
- 95/4** Valeur "x" = Longueur du point, à préciser à la commande.
- 96** Préciser longueur.
- 96/4** Flexible d'un diamètre intérieur de 4 mm; préciser la longueur.
- 96/6** Flexible d'un diamètre intérieur de 6 mm; préciser la longueur.

- B** Tipo B
- C** Tipo C
- 4,5** Largo de puntada 4,5 mm
- N** Largo de puntada 6,0 mm
- 3** Pieza pegada
- 4** Indíquese el tipo en los pedidos
- 5** Envíese muestra de costura.
- 6** Grosor de aguja y forma de la punta, indíquese en los pedidos.
- 10** Distancia entre agujas.
- 10/1** La forma varía de acuerdo con la distancia entre agujas (p.e. el número del hilera de dientes en el transportador)
- 10/2** Indíquese en los pedidos la distancia entre agujas.
- 27/5** Cifra entre paréntesis = largura en mm.
- 30** Tipo anterior, en caso de sustitución pidase de nuevo.
- 30/2** Tipo anterior, se sustituye por el N^o 11-210 168-15
- 30/3** Tipo anterior, se sustituye por el nuevo tipo N^{os} 91-140 834-91; 91-140 133-92 y 91-140 803-05.
- 32** Al montar esta pieza no se asume garantía alguna en cuanto a la tolerancia y precisión de ajuste respecto a la pieza correspondiente; por esta razón se recomienda pedir el grupo completo.
- 40/1** Rellene con aceite 280-1-120 144; para el N^o de pedido, véase la Tabla de lubricantes
- 40/3** Engrase con grasa 280-1-120 247; para el N^o de pedido, véase la Tabla de lubricantes
- 40/8** Empape con aceite 280-1-120 122; para el N^o de pedido, véase la Tabla de lubricantes
- 40/13** Engrase con grasa 280-1-120 205; para el N^o de pedido, véase la Tabla de lubricantes
- 80/4** Para tubo de plástico de 4 mm diámetro interior.
- 80/6** Para tubo de plástico de 6 mm diámetro interior.
- 90/5** Para conectar el posicionador Quick B/1 a la caja de mandos con enchufe de 4 polos.
- 90/6** Para conectar el posicionador Quick B/K a la caja de mandos con enchufe de 7 polos.
- 90/9** Para motores con número de modelo de 8 cifras.
- 95/4** Valor x = Largo de puntada, indíquese en los pedidos.
- 96** Indíquese la largura
- 96/4** Tubo flexible de 4 mm de diámetro interior; indíquese la largura en los pedidos.
- 96/6** Tubo flexible de 6 mm de diámetro interior; indíquese la largura en los pedidos.

Pfaff 346-H3
Pfaff 646-706/47

CSTMP

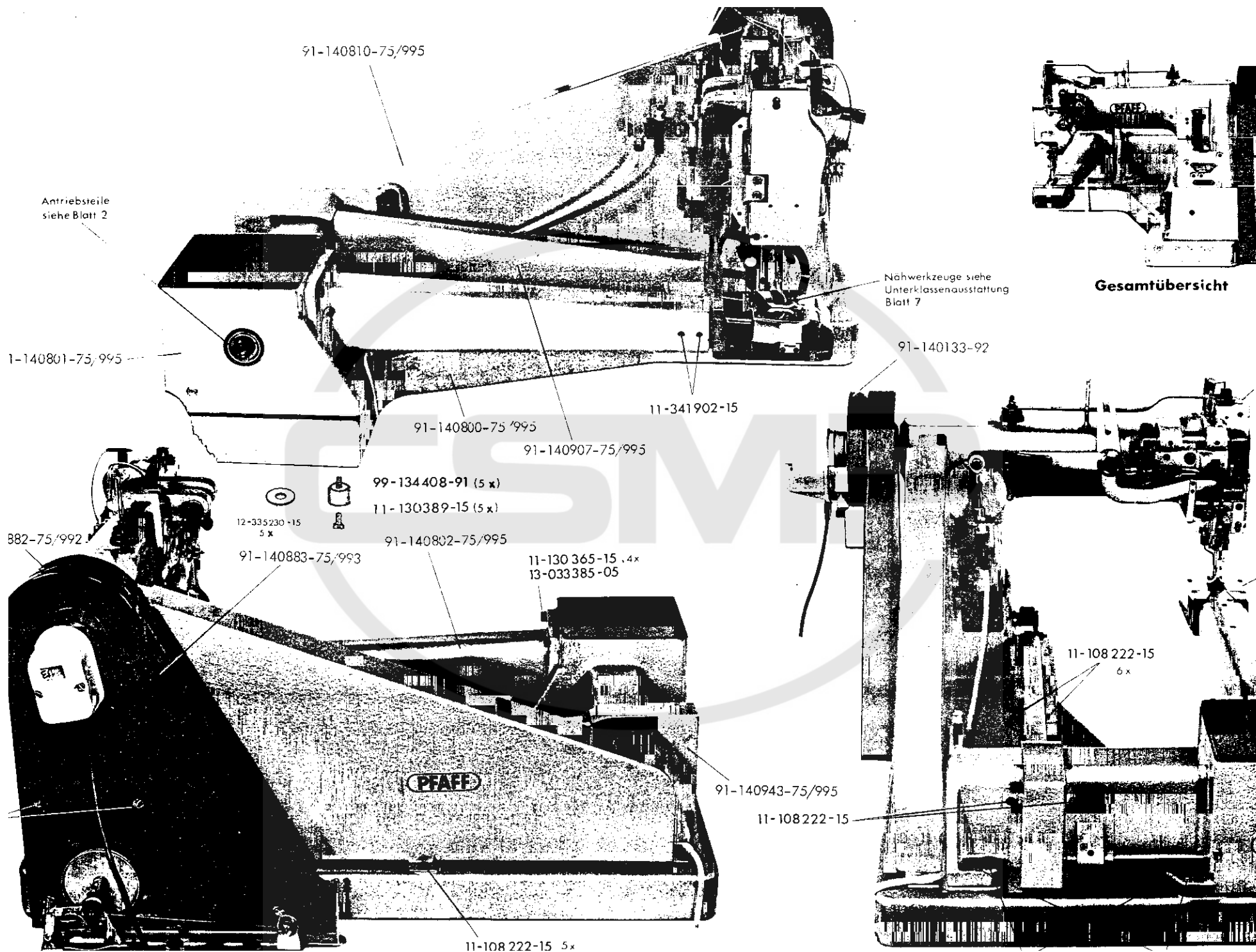

91-140810-75/995

Antriebsreile
siehe Blatt 2

1-140801-75/995

Nähwerkzeuge siehe
Unterklassenausstattung
Blatt 7

Gesamtübersicht

91-140133-92

11-341902-15

91-140800-75/995

91-140907-75/995

99-134408-91 (5 x)

11-130389-15 (5 x)

91-140802-75/995

11-130365-15 4x
13-033385-05

882-75/992

12-335230-15
5 x

91-140883-75/993

11-108222-15
6 x

91-140943-75/995

11-108222-15

11-108222-15 5x

PFÄFF

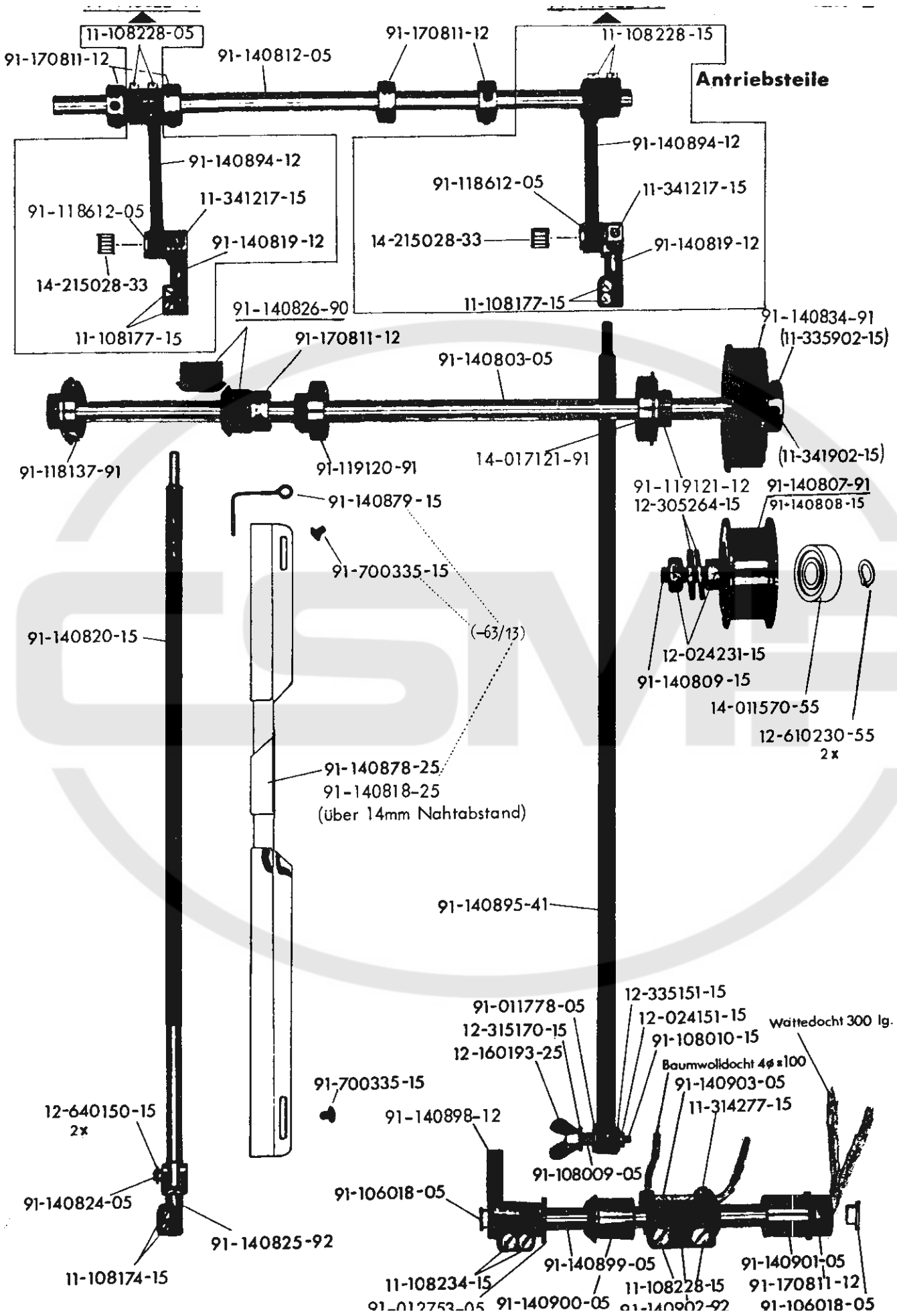

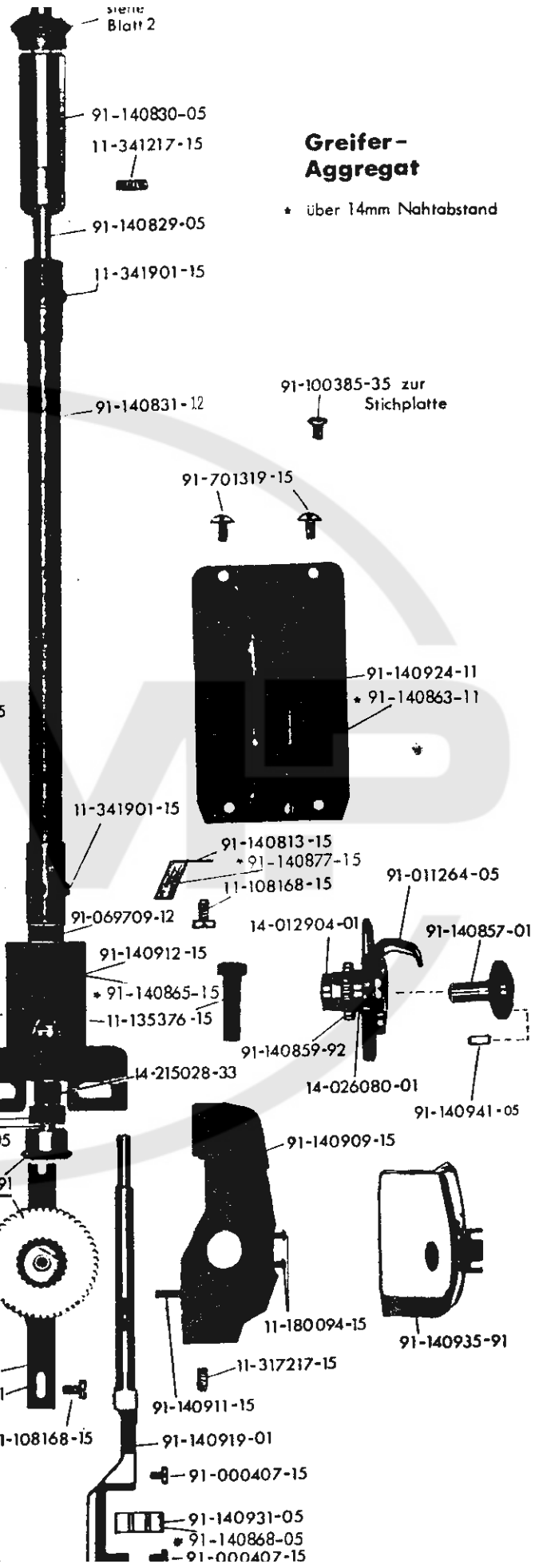
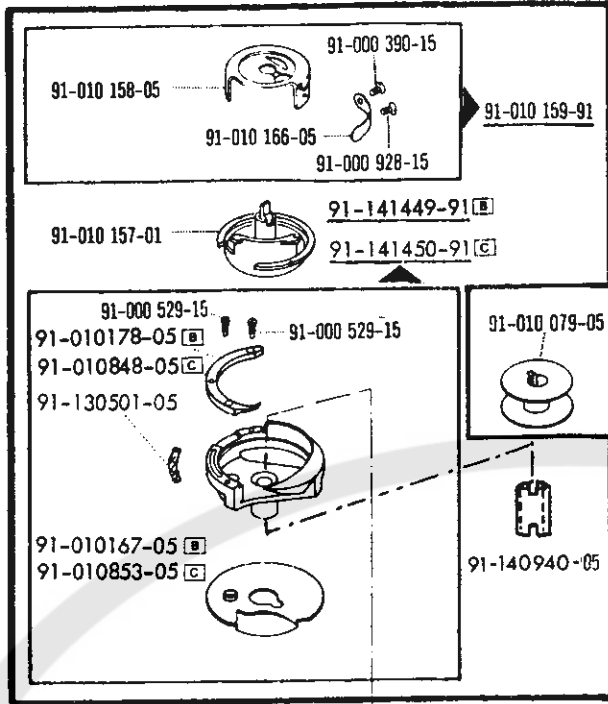

Greifer-Aggregat

* über 14mm Nahtabstand

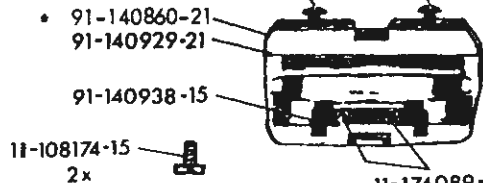

Pfaff 346-H3

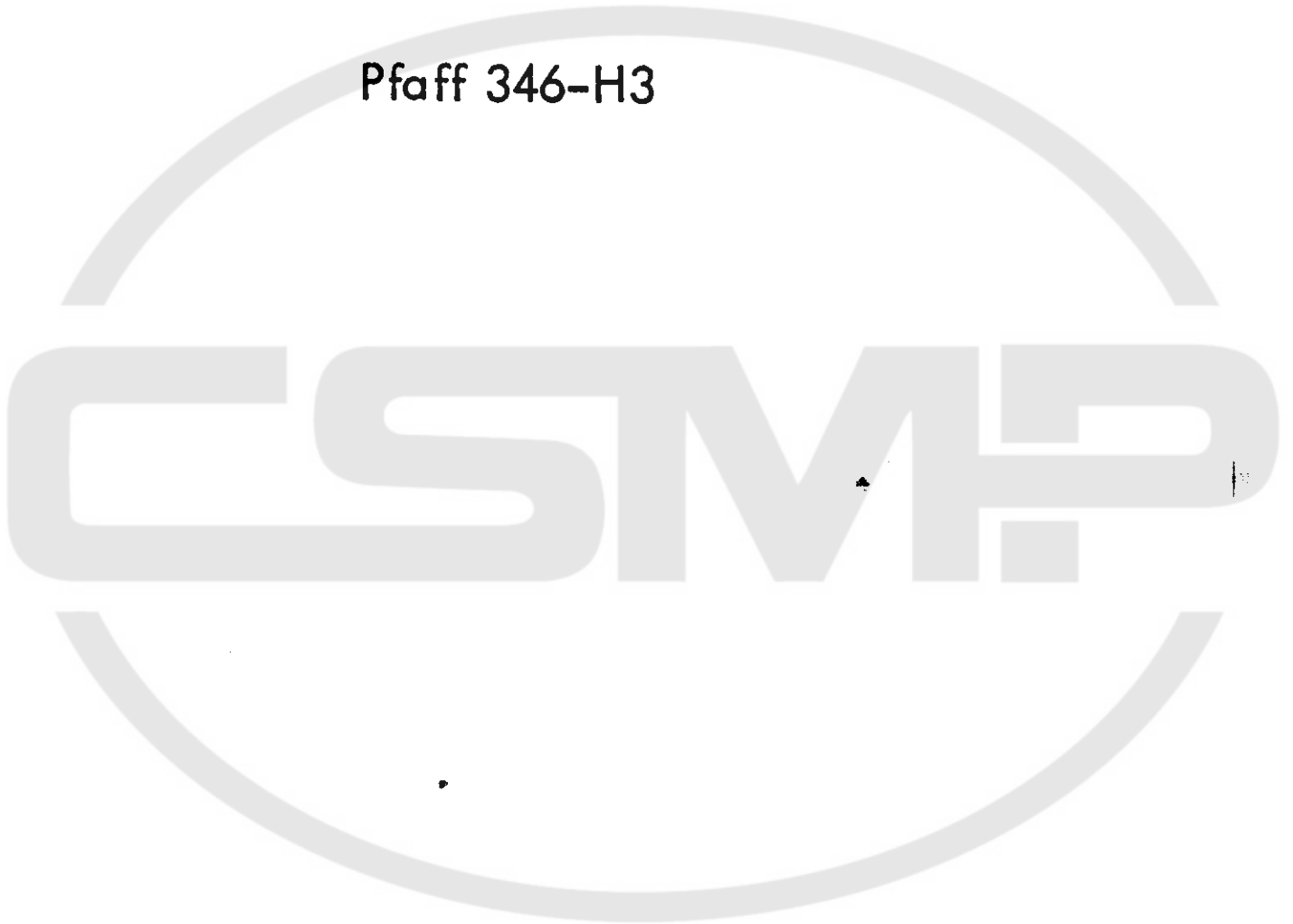

4.1 Obergehäuseteile
Housing parts
Pieces de la carcasse
Piezas de la carcasa

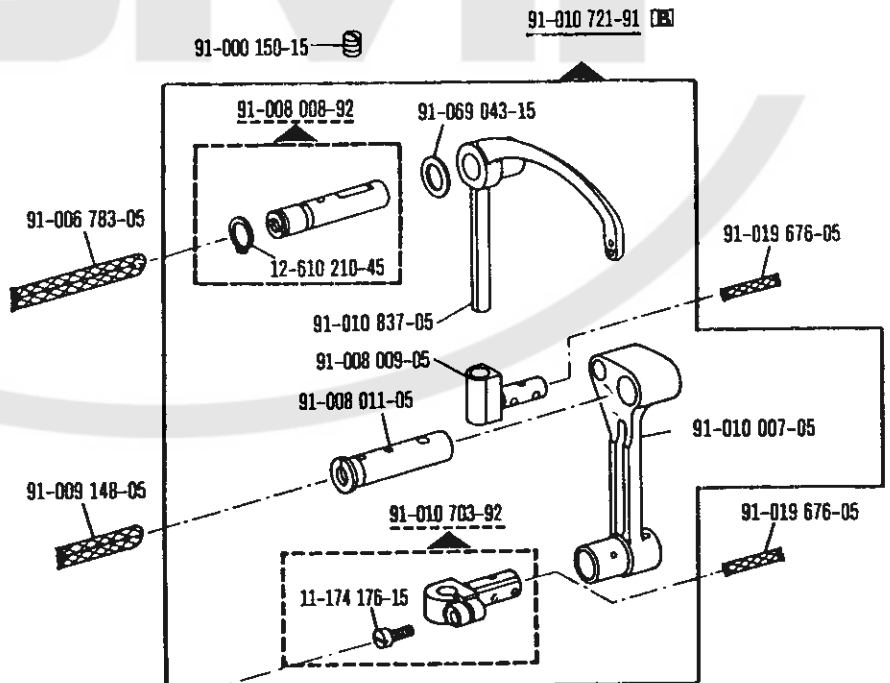
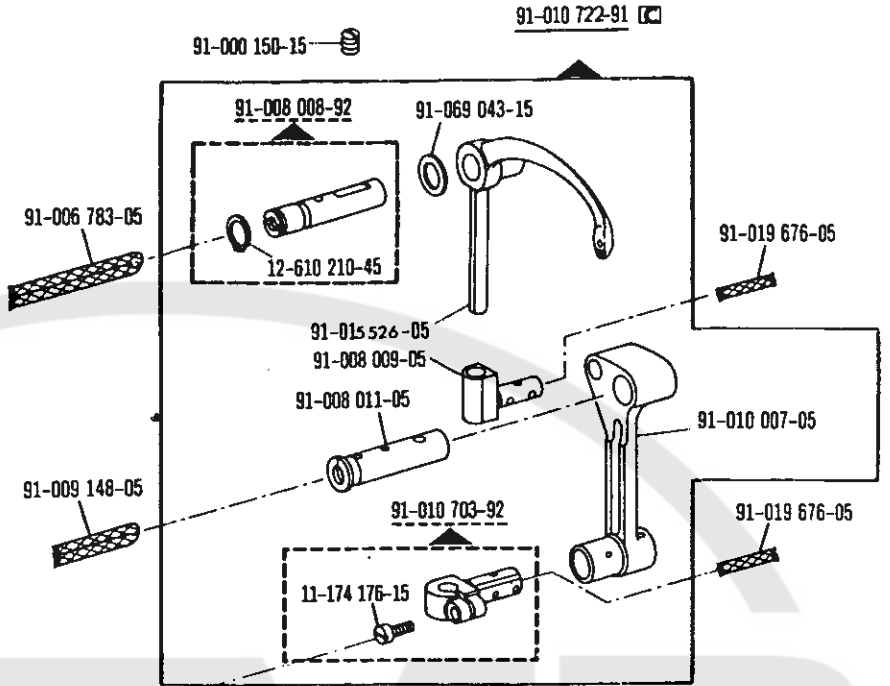
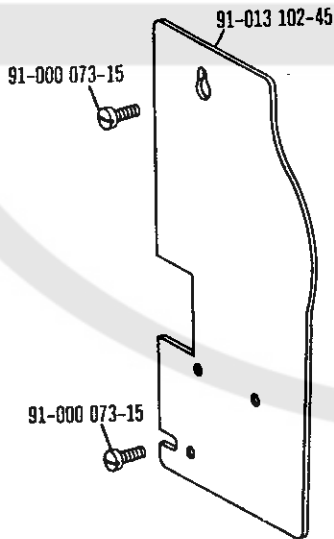
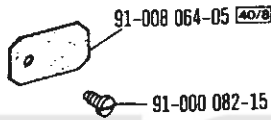
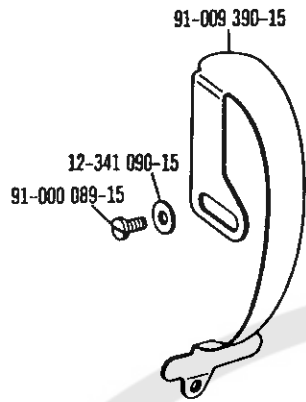

91-113 017-91 **B** 91-018799-91 **C**

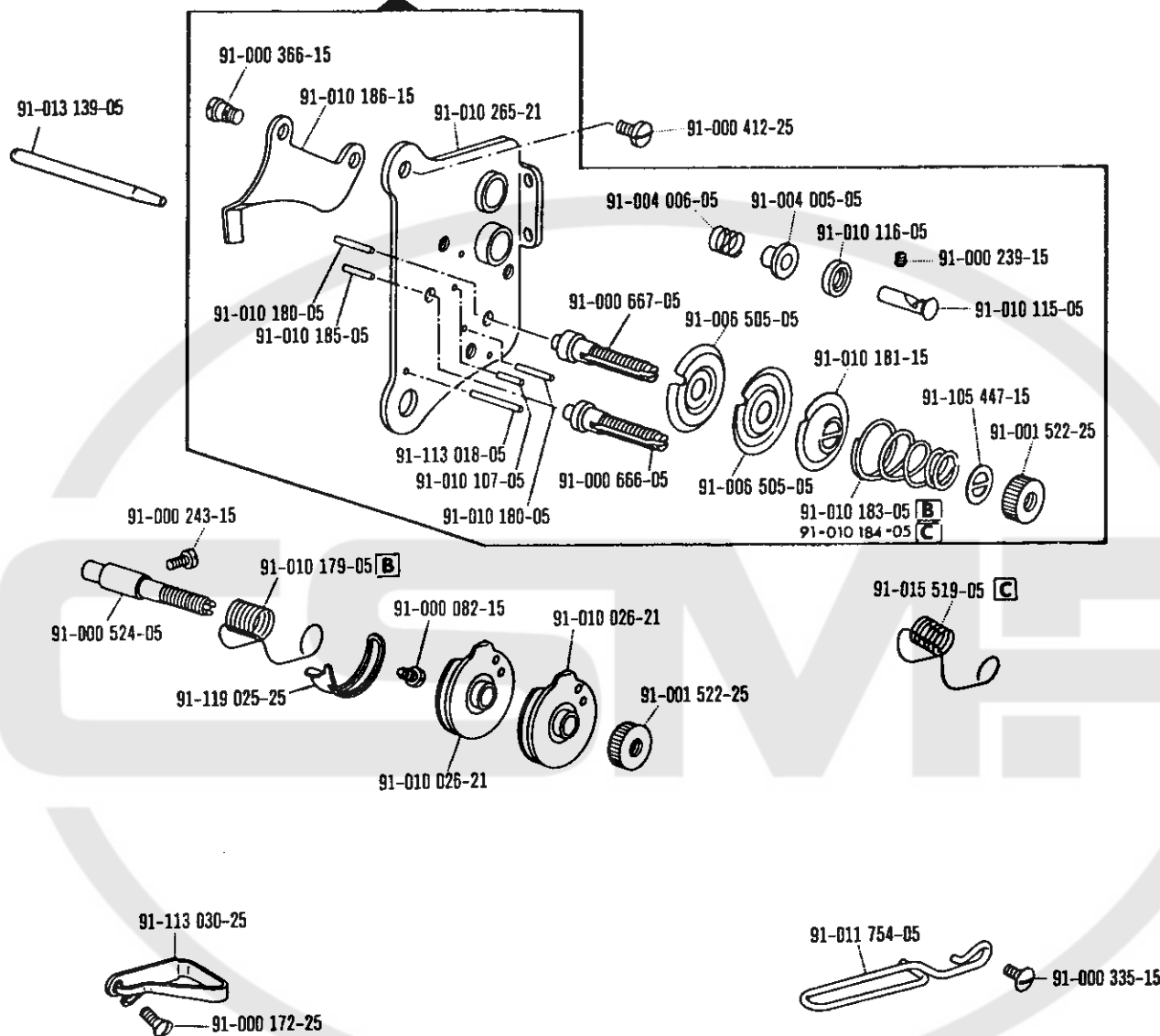

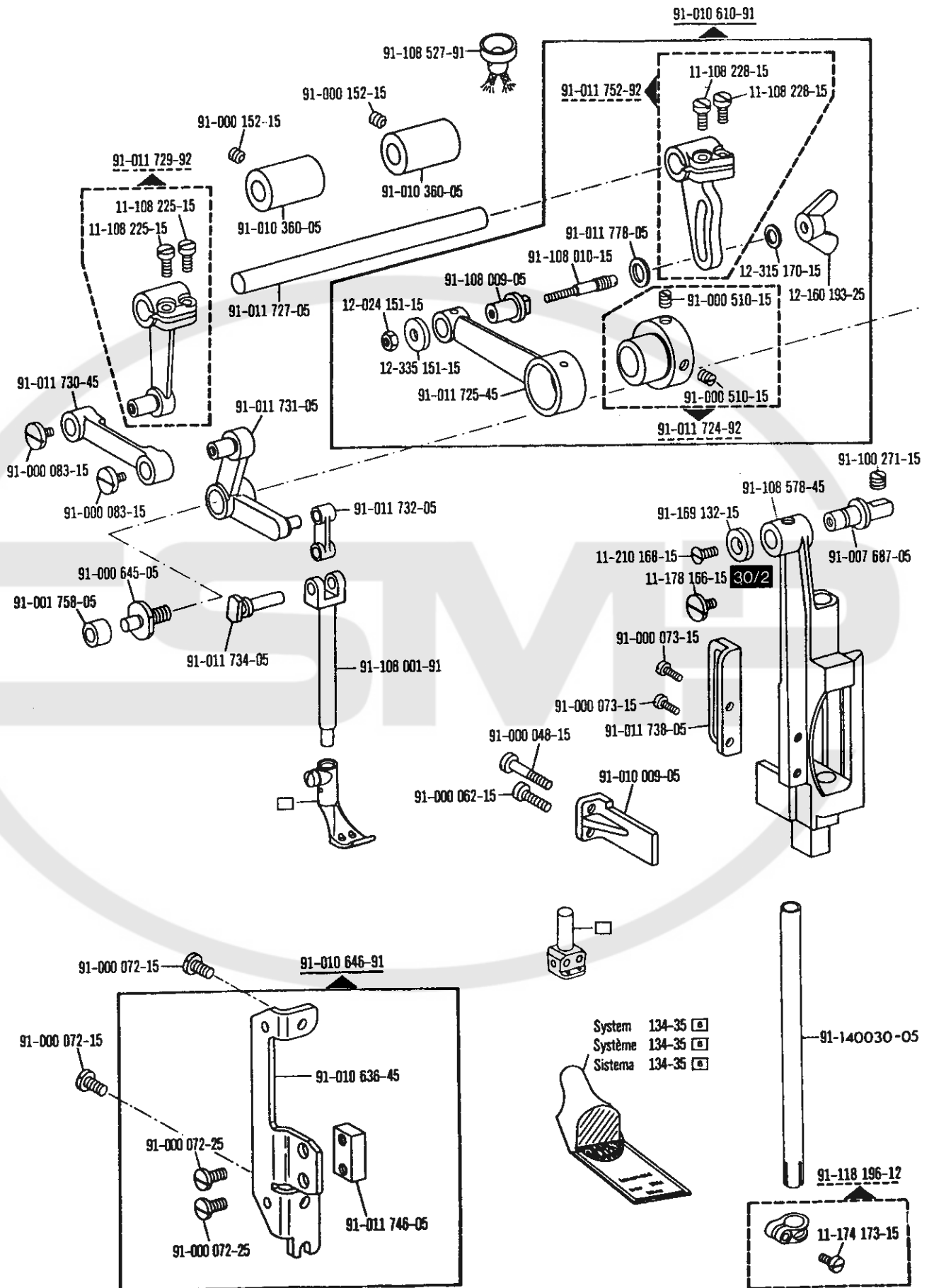

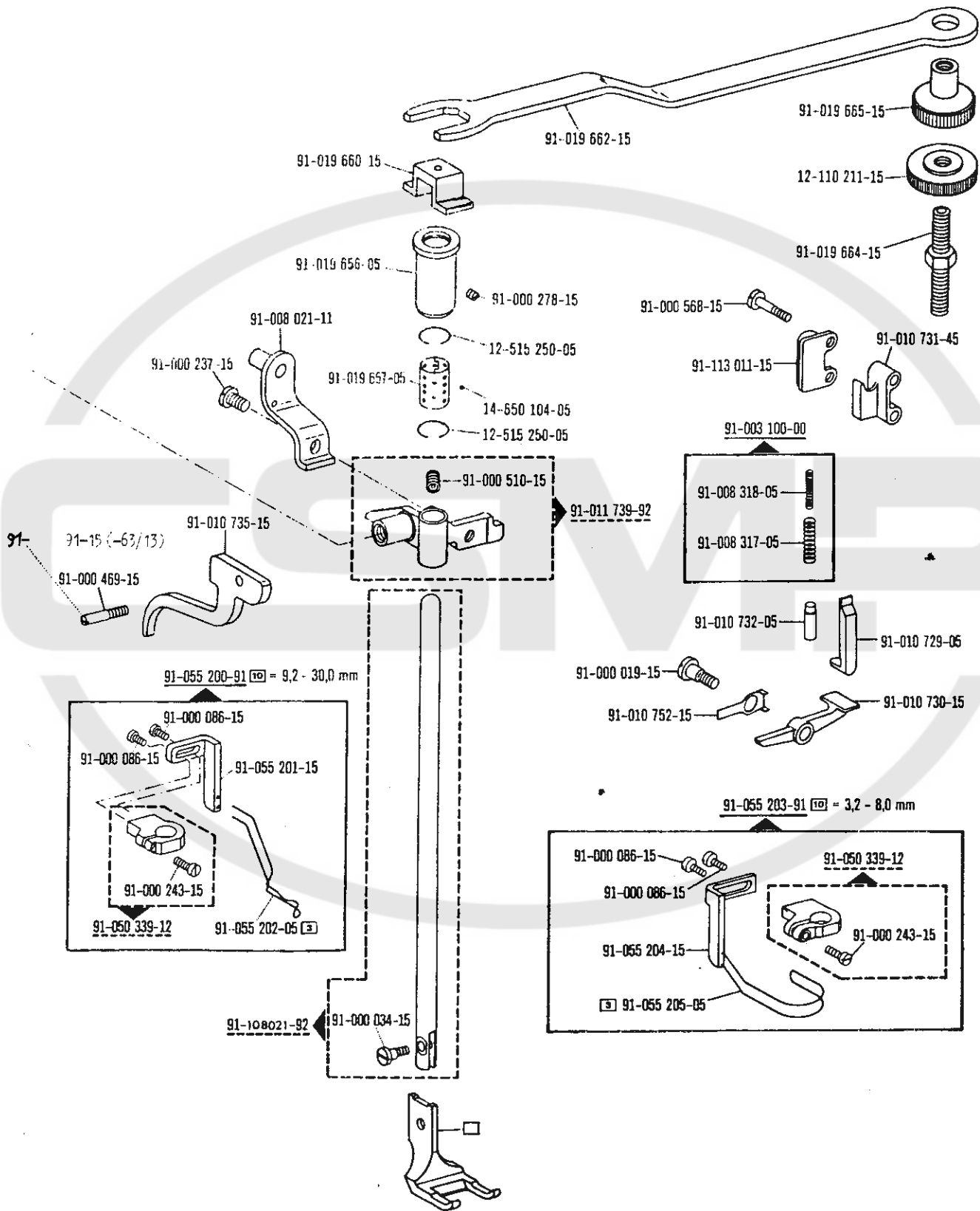

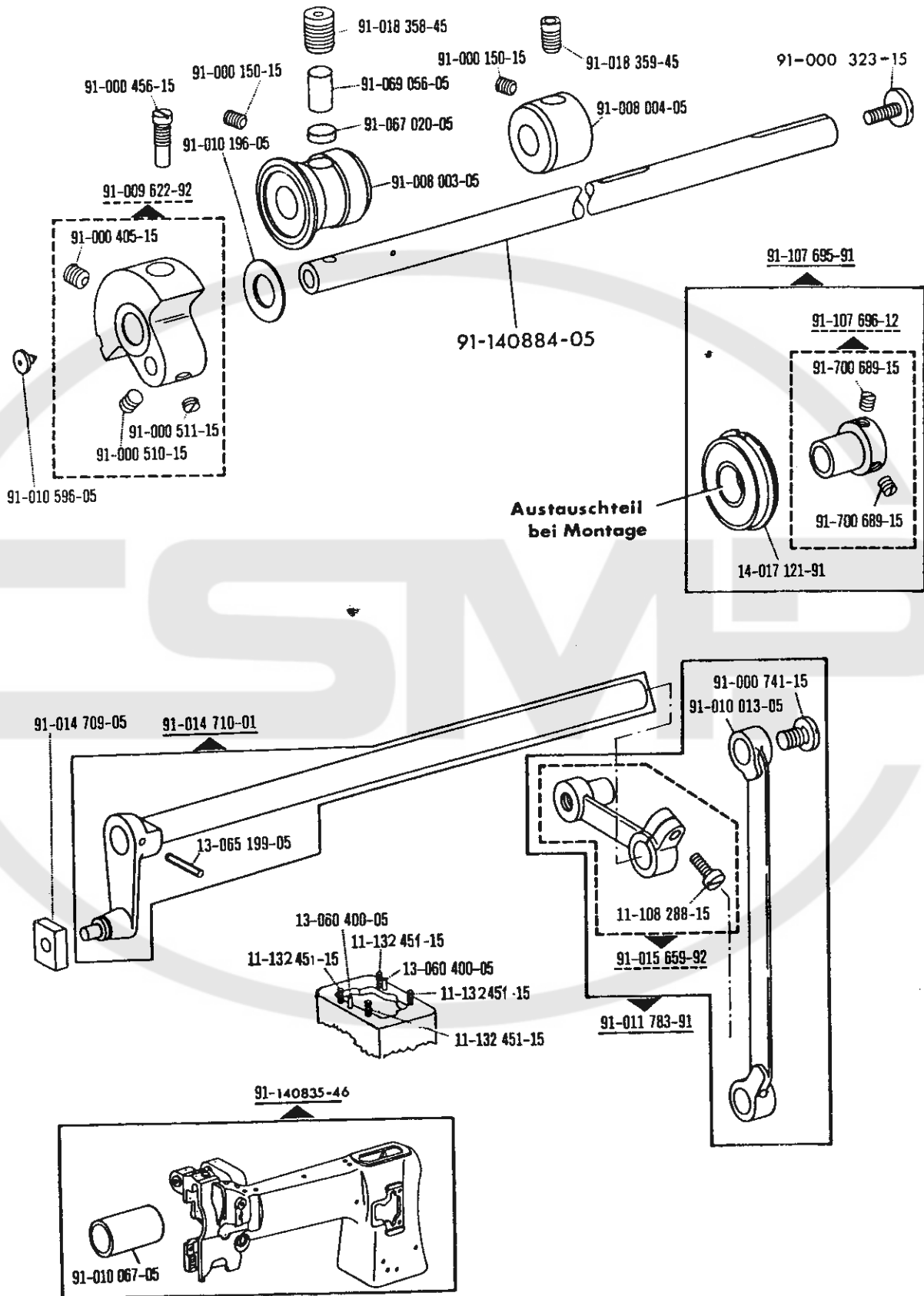

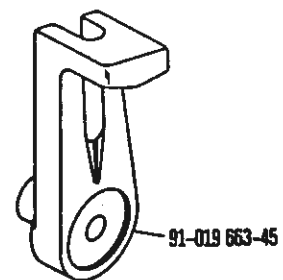
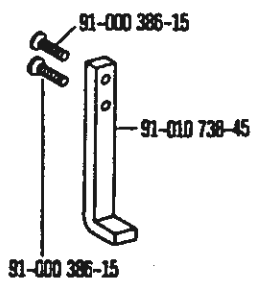
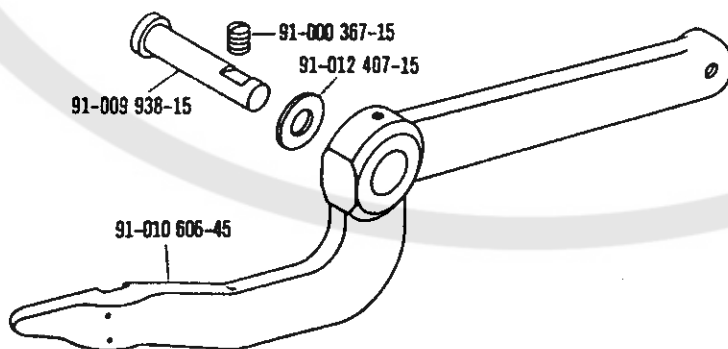
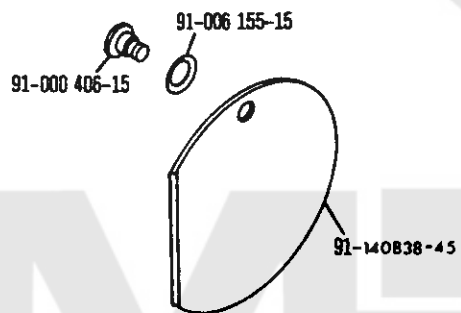
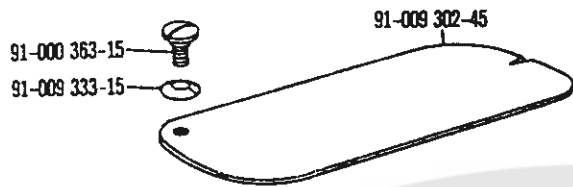

4.7

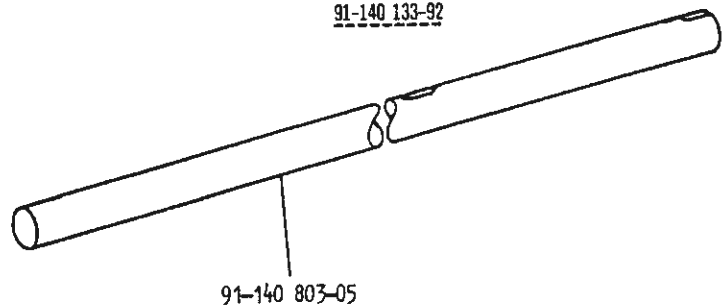
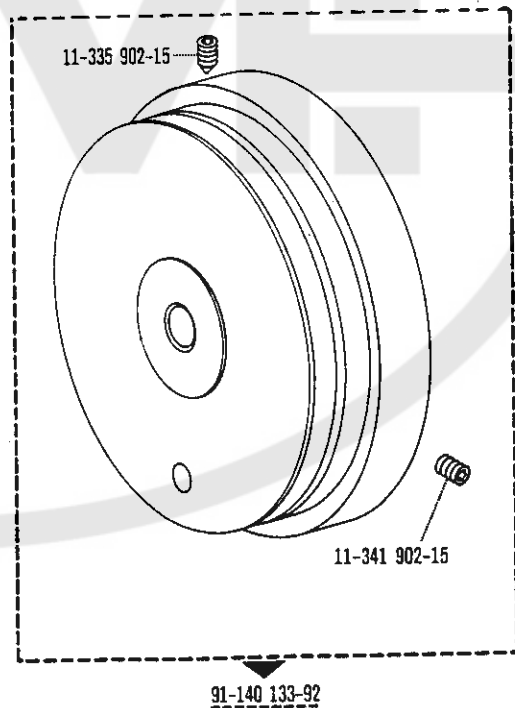
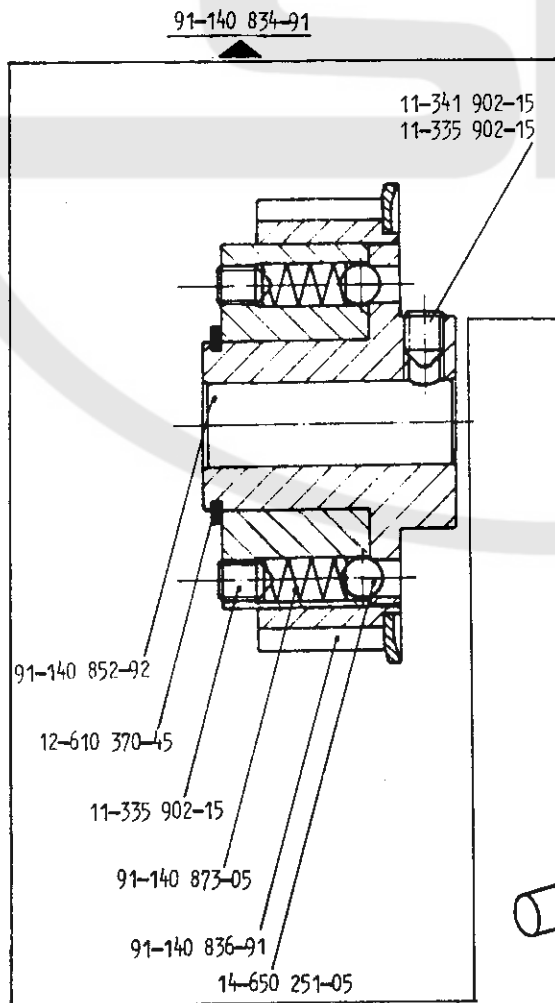
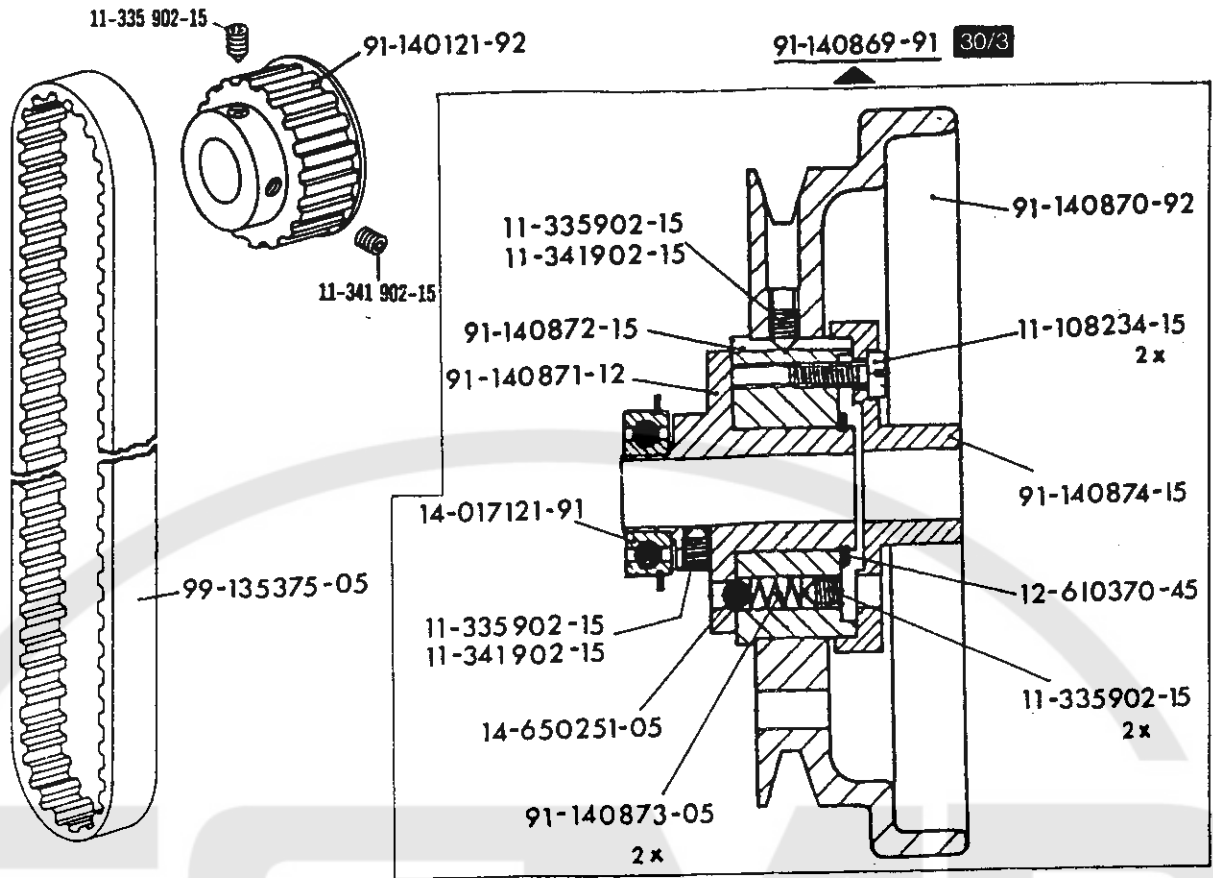

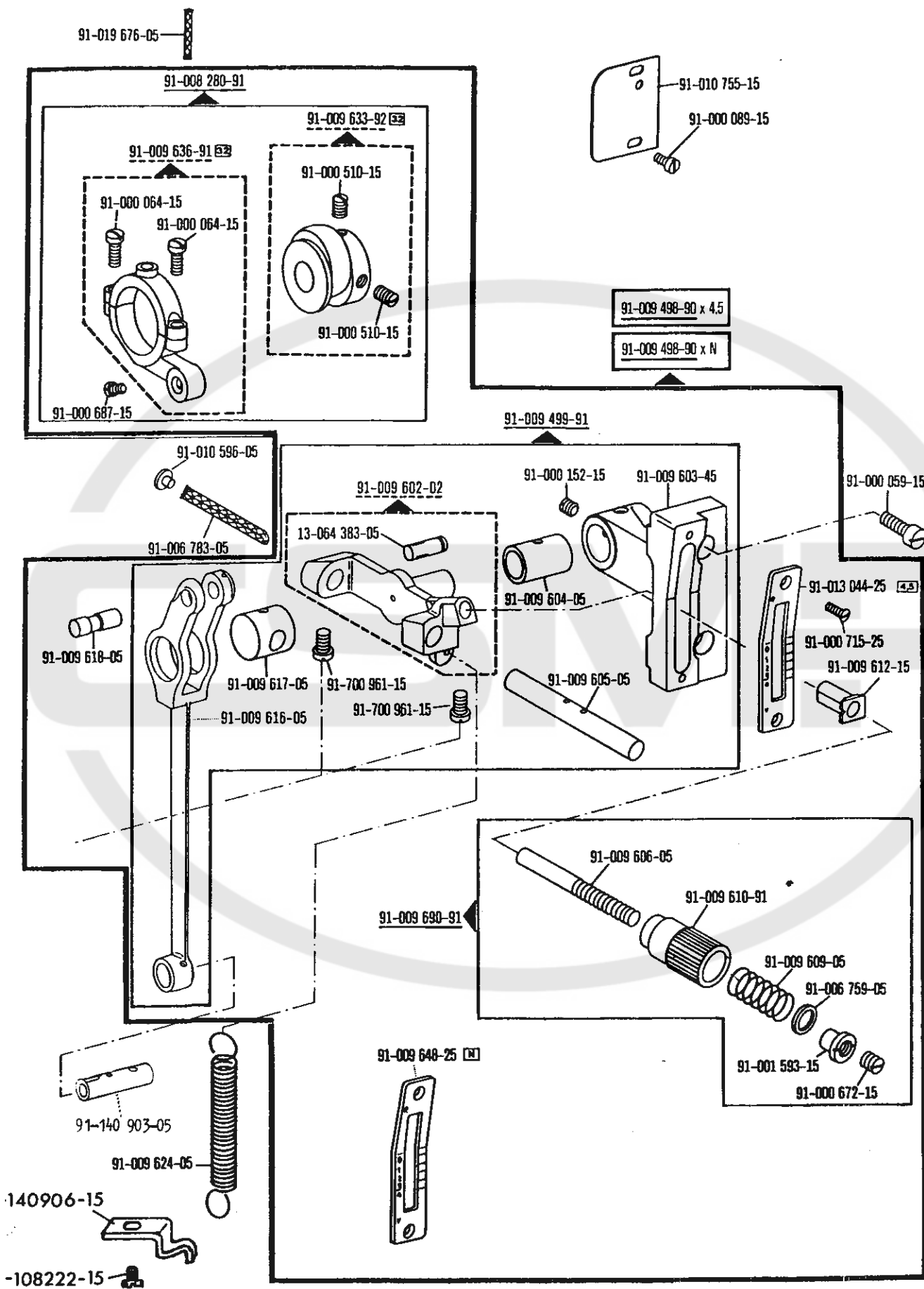

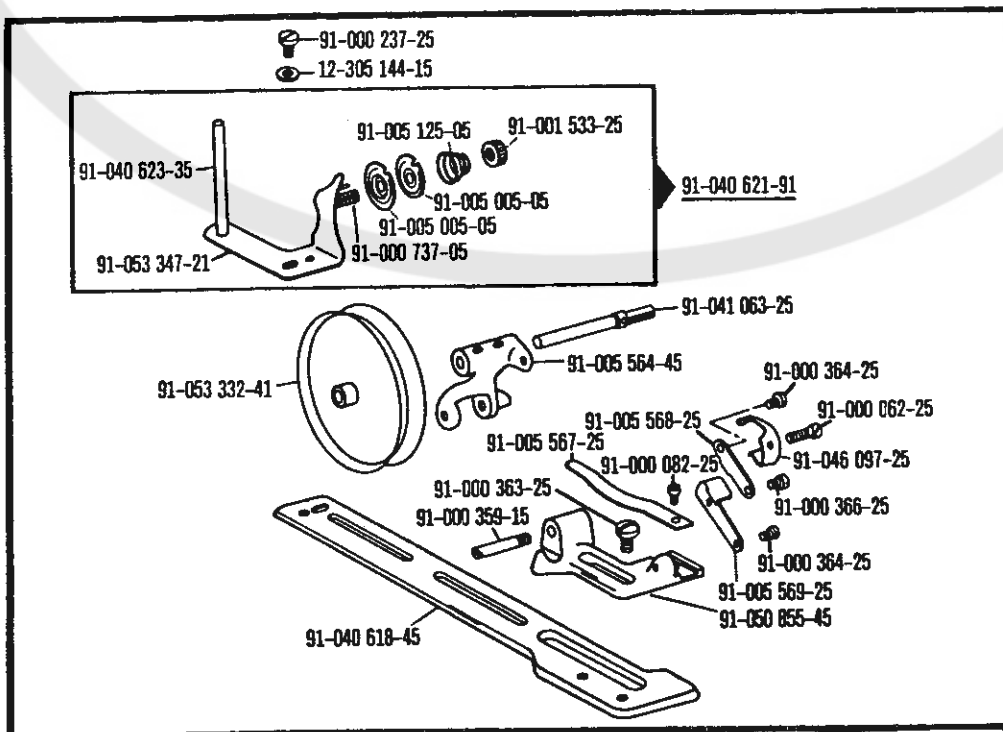
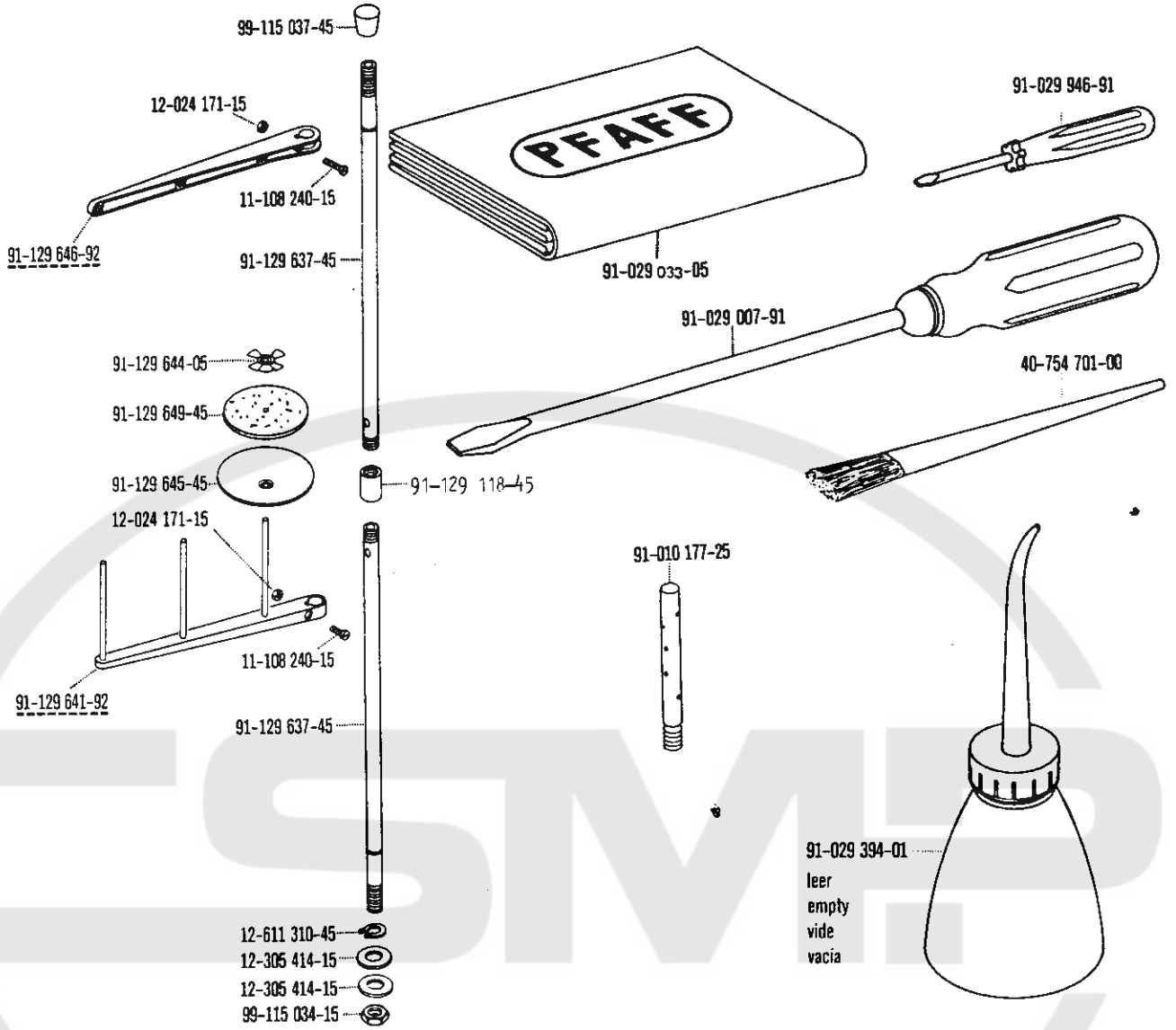

-910/04

Bausatz
91-012134-90

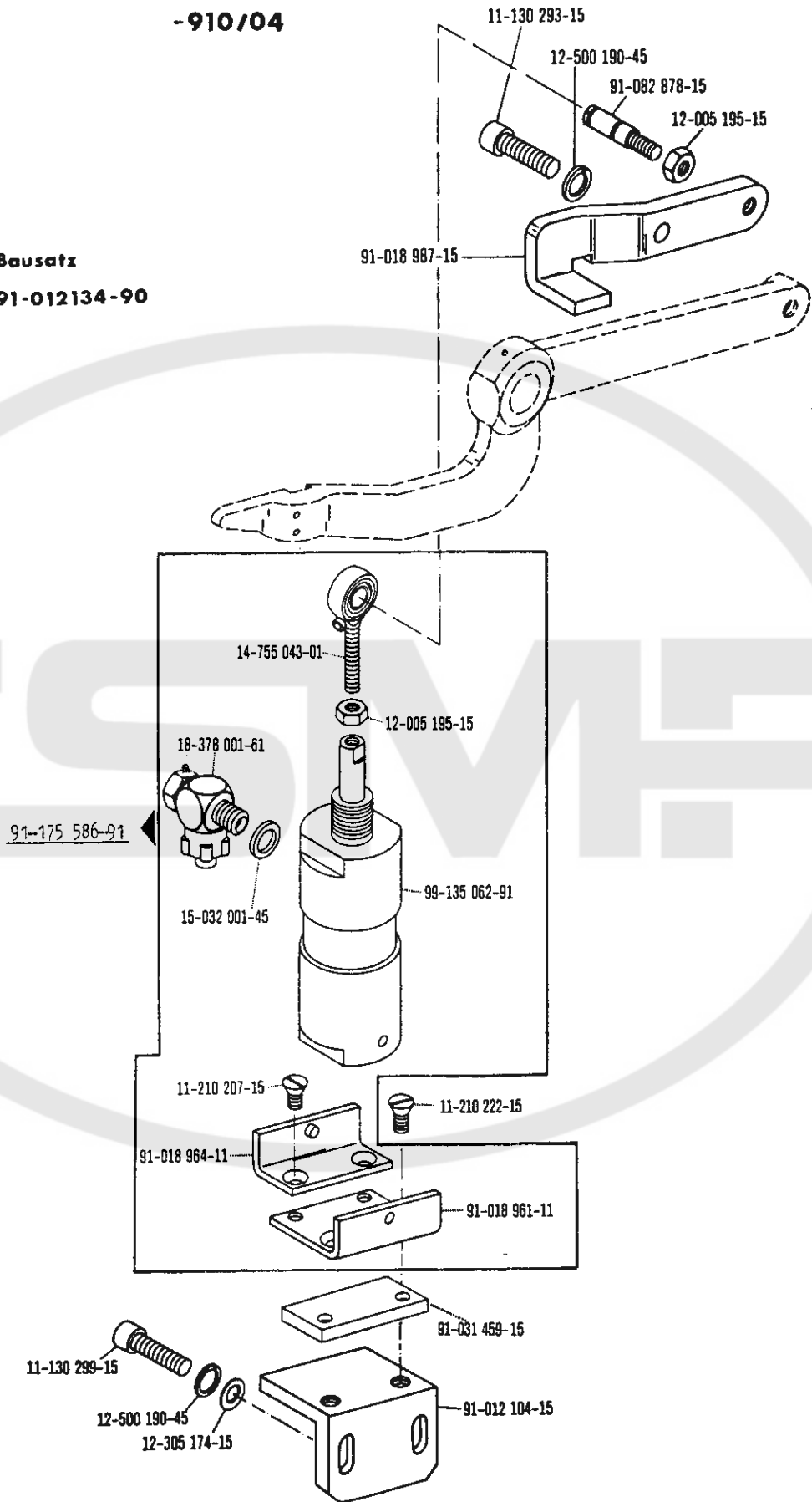

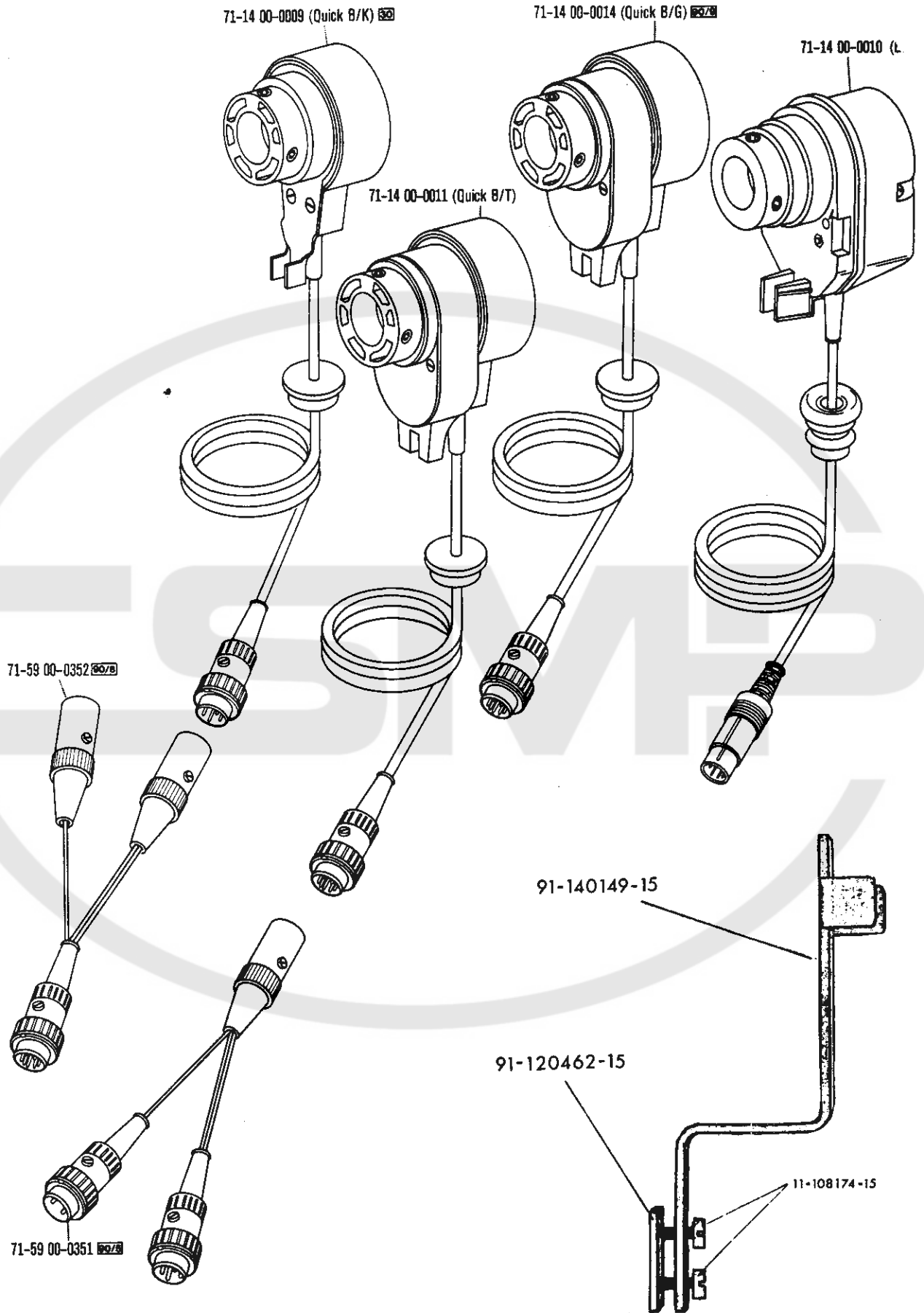

-925/01

91-171 462-90

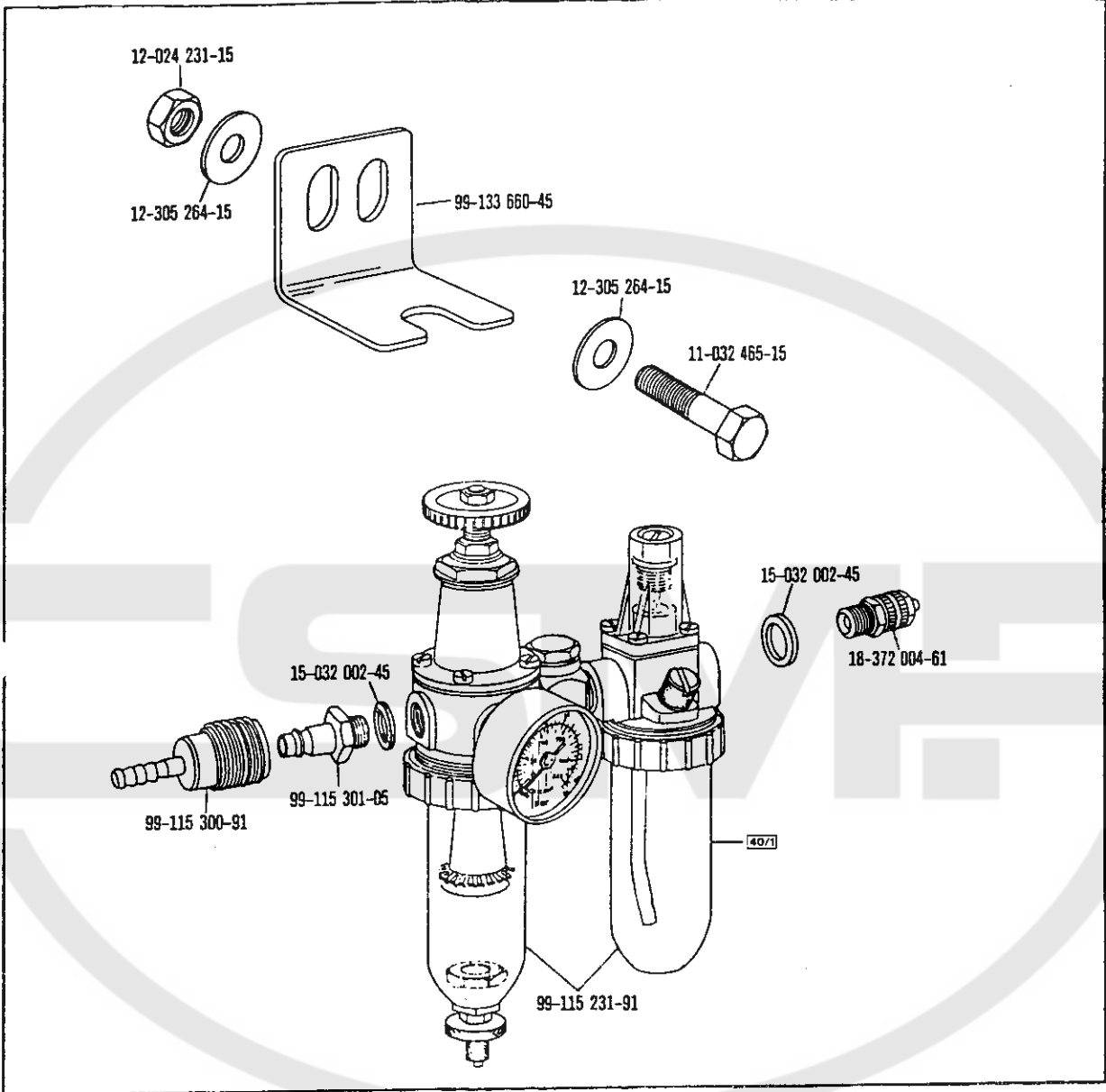

25 134-8.005-0

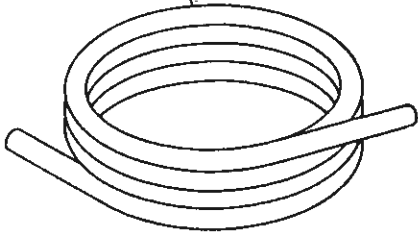

Pfaff 646-706/47



Obergehäuseteile
Housing parts
Pieces de la carcasse
Piezas de la carcasa

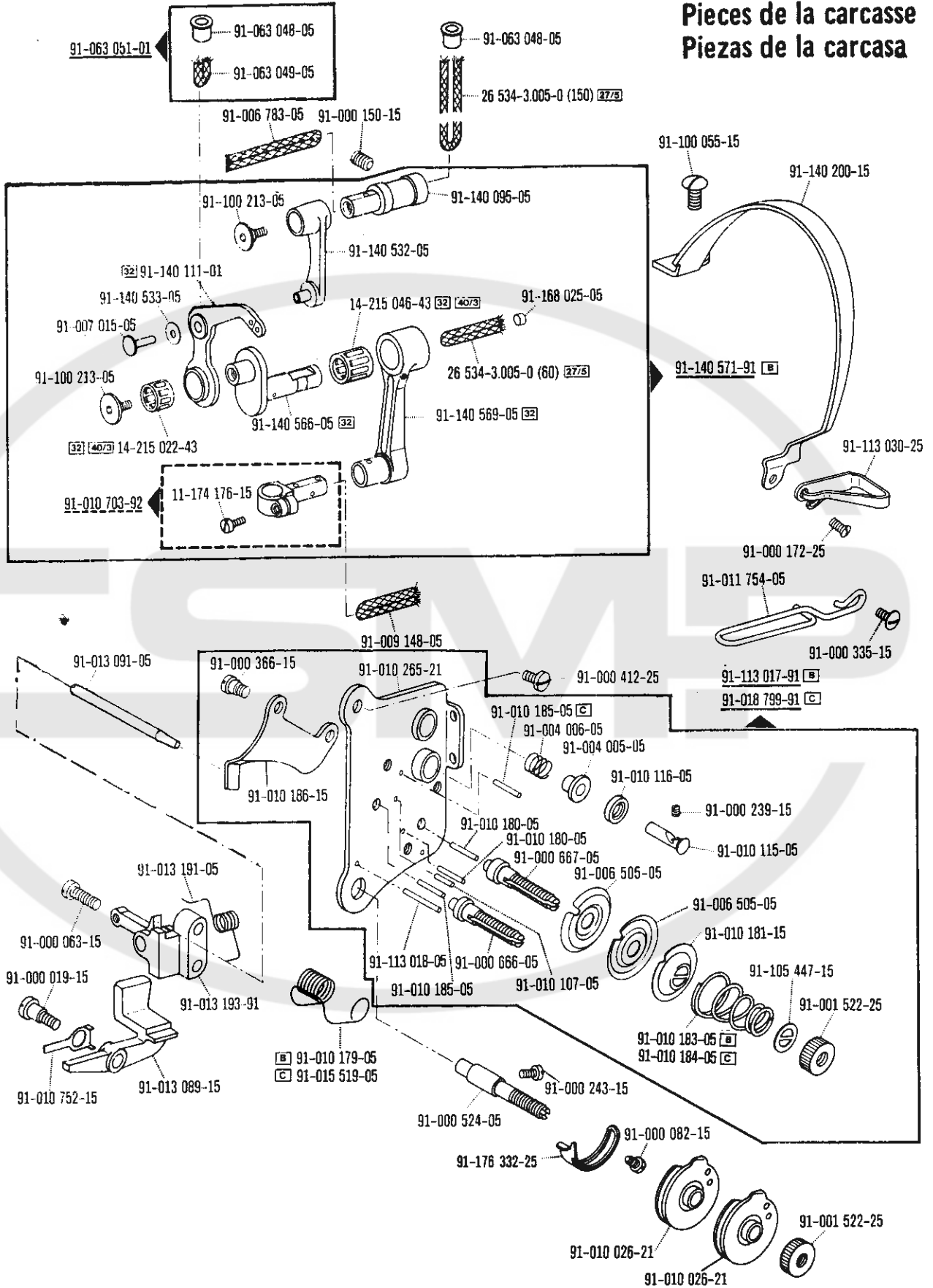

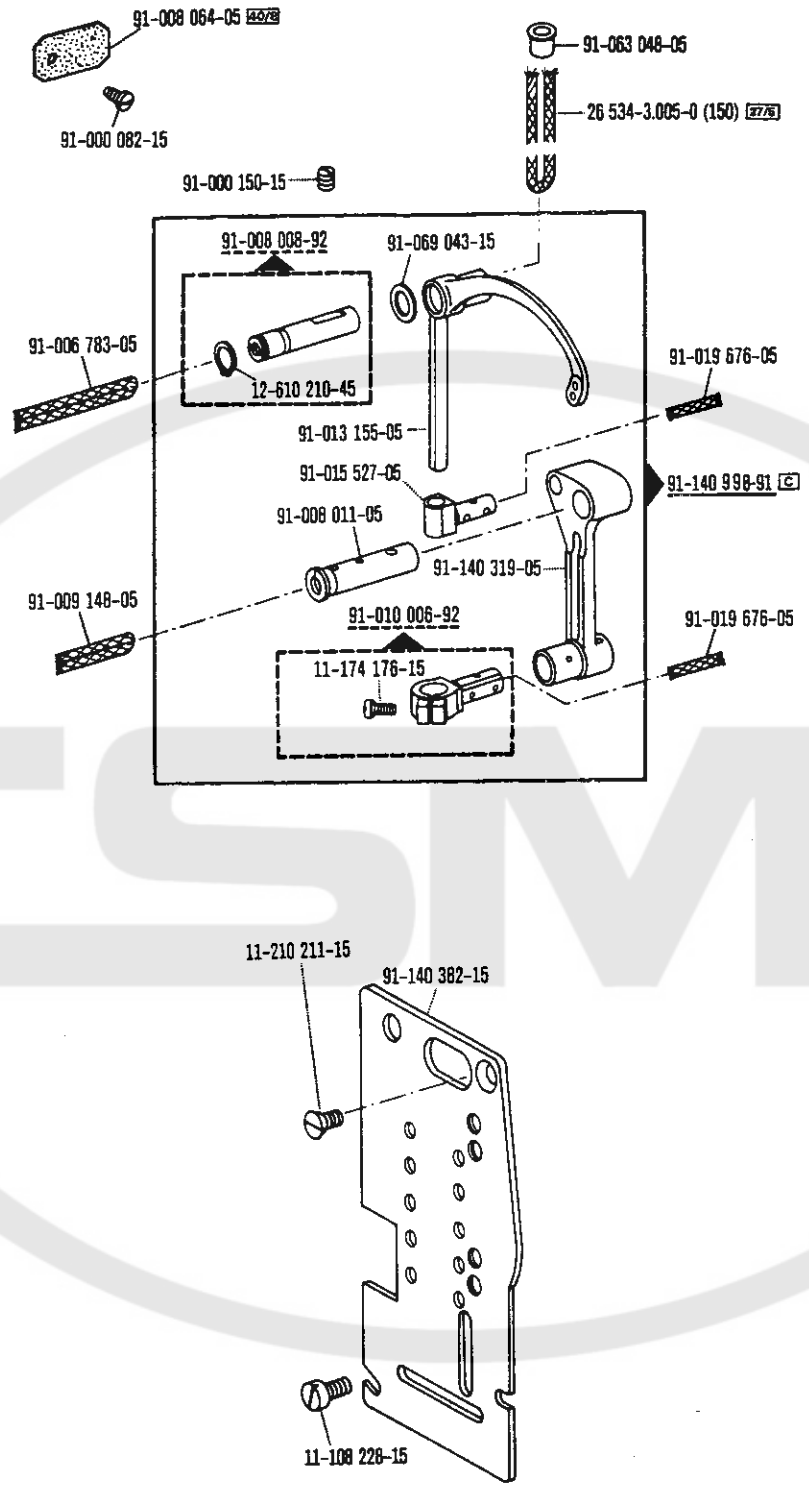

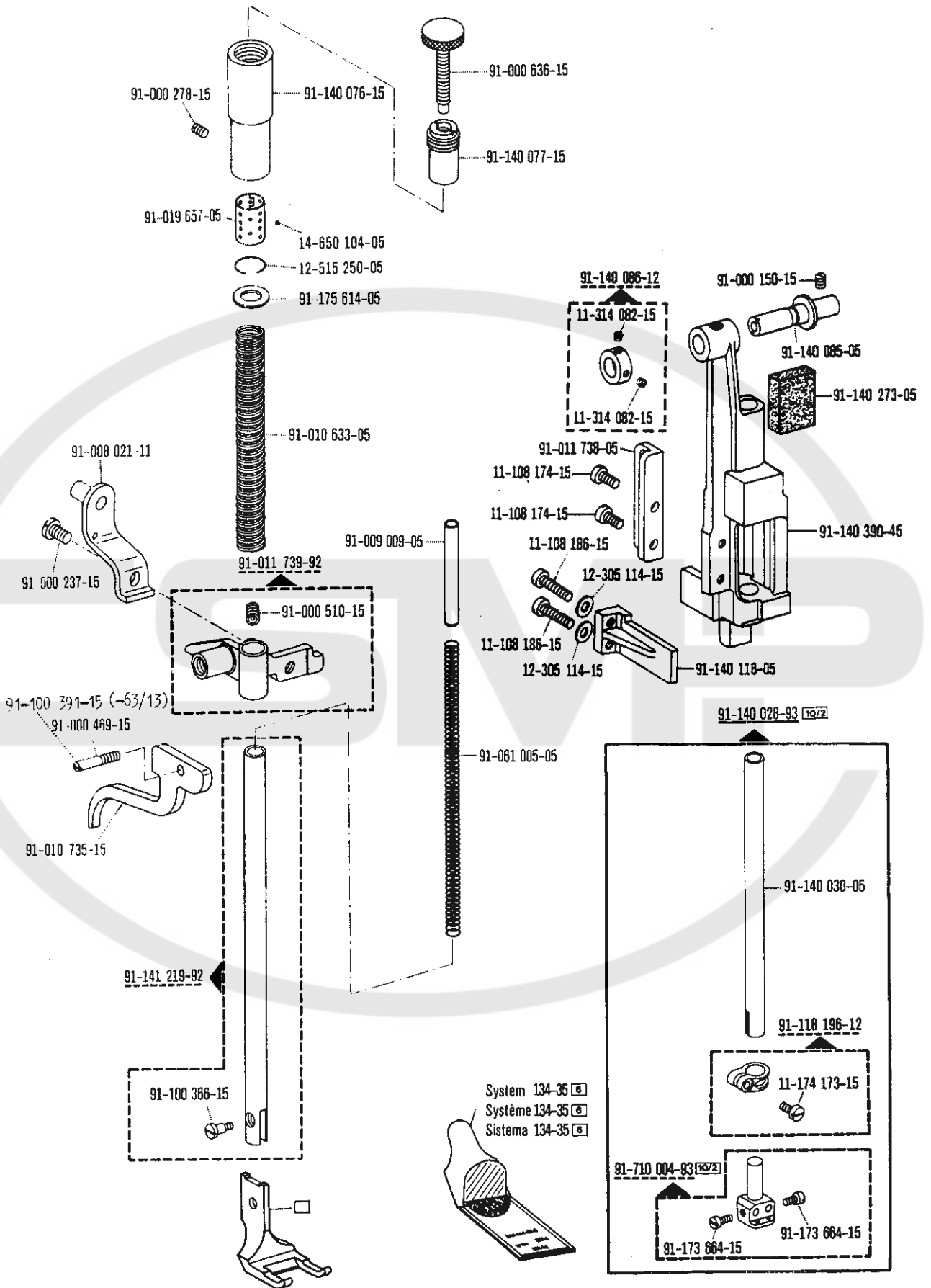

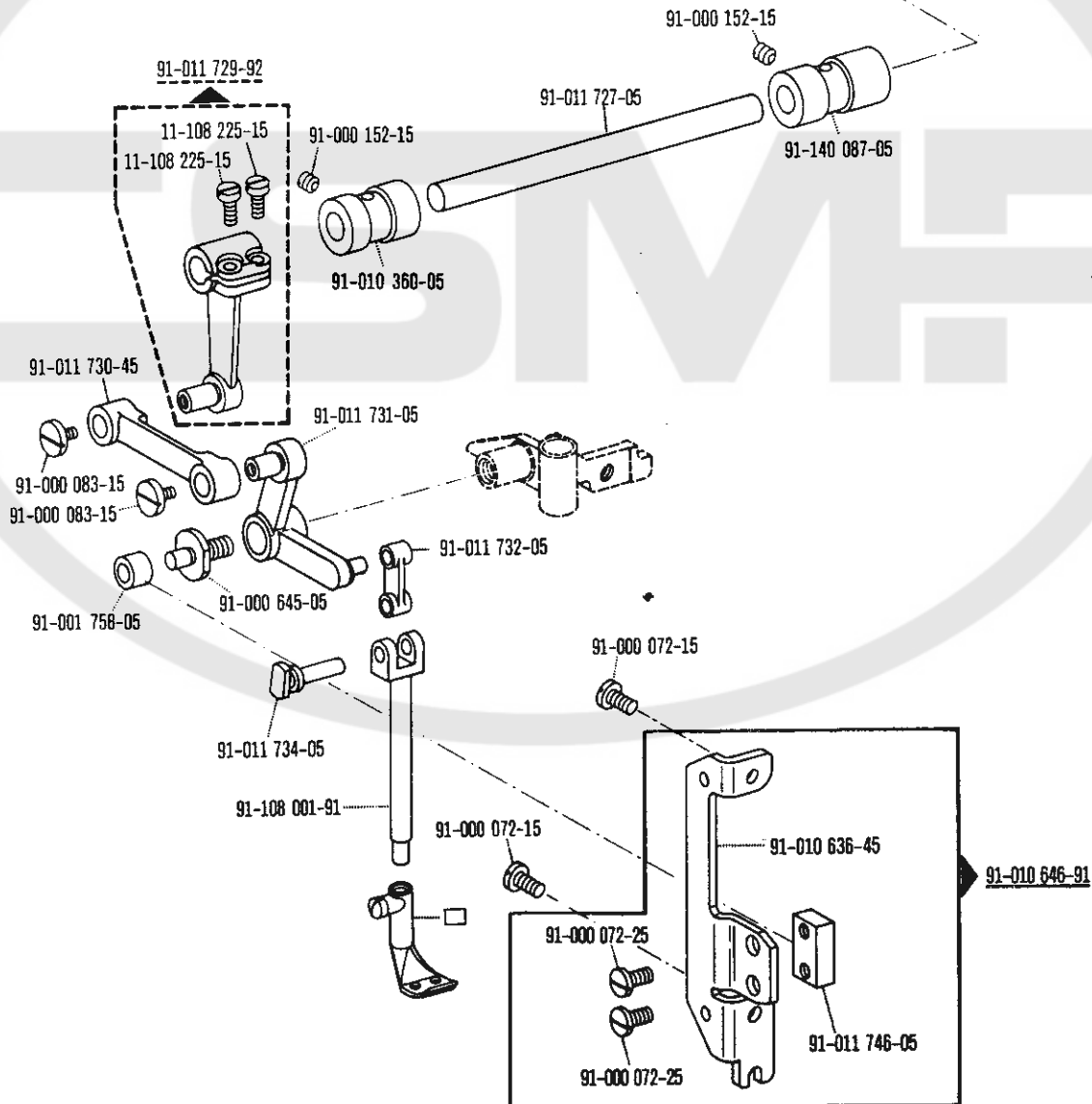
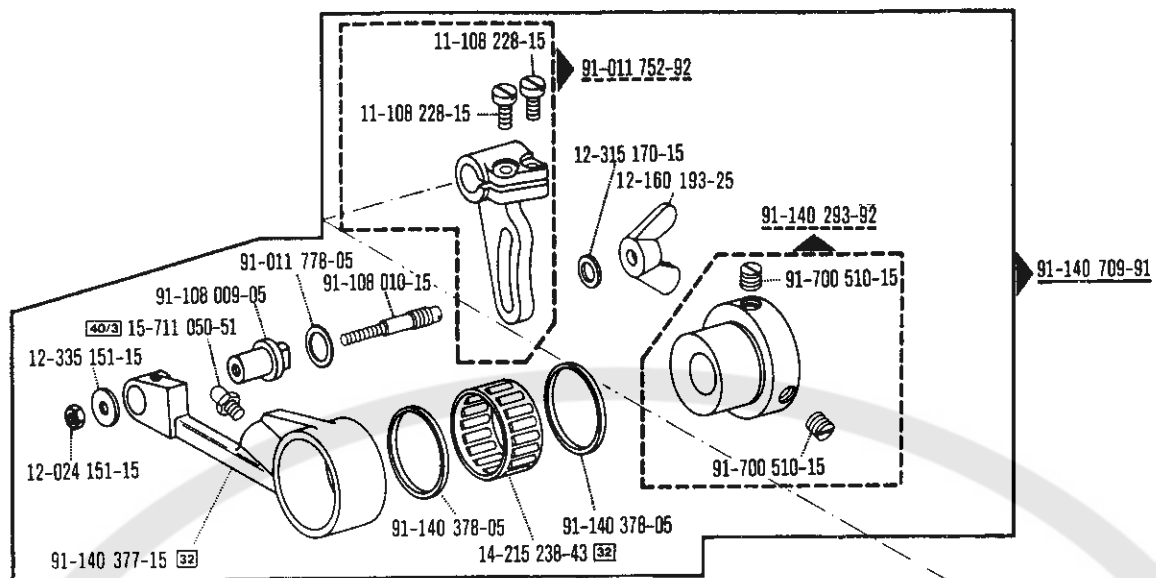

5.5

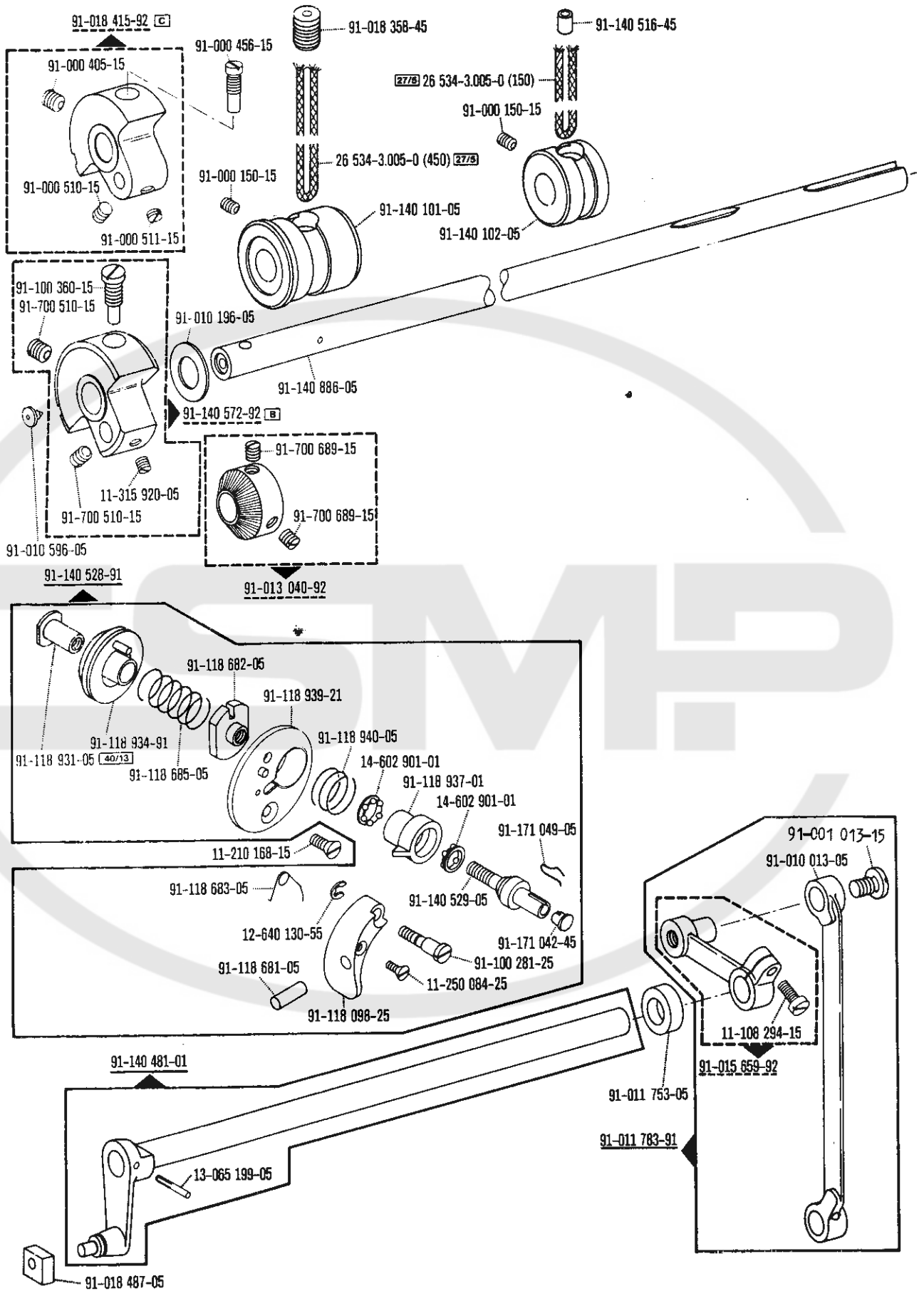

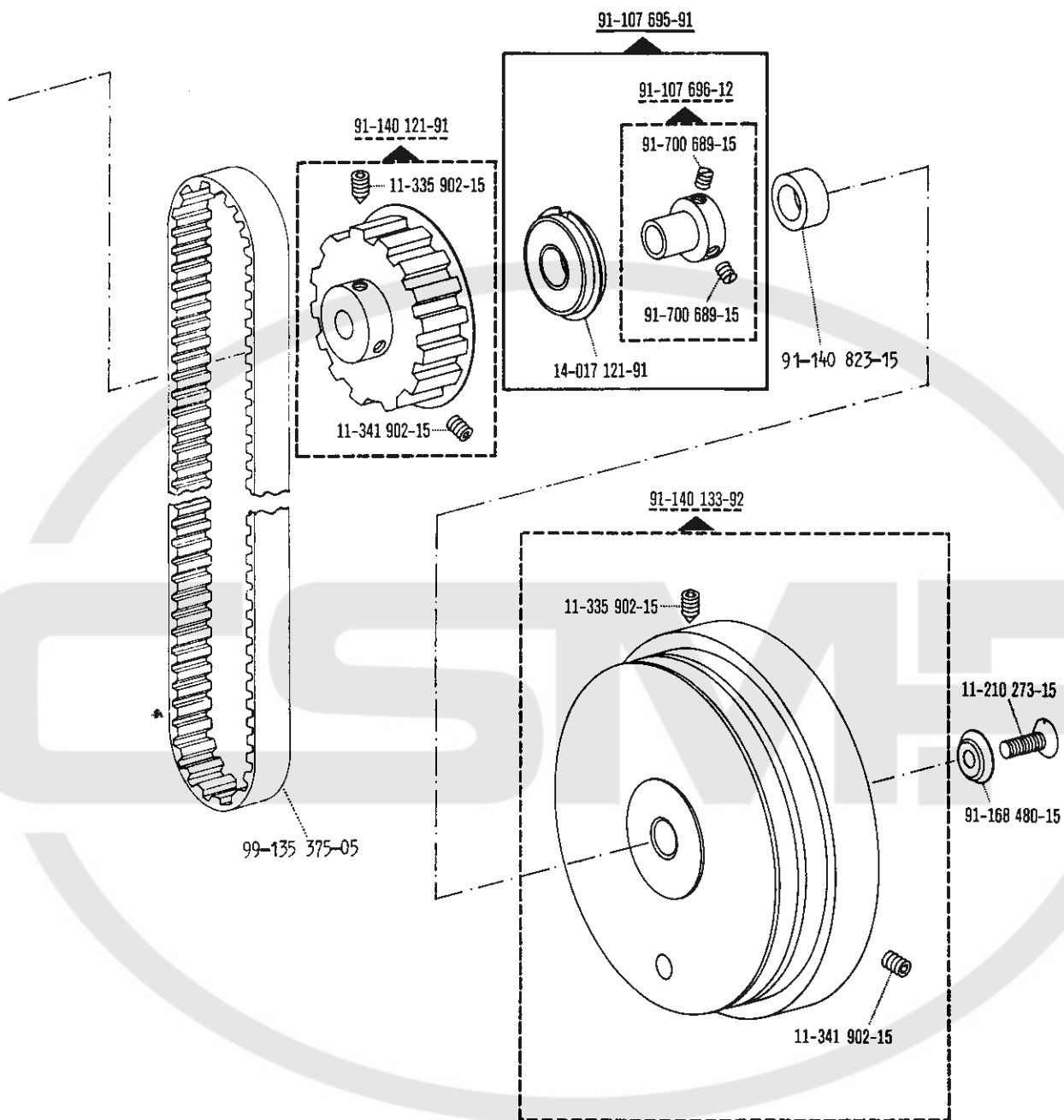

5.7

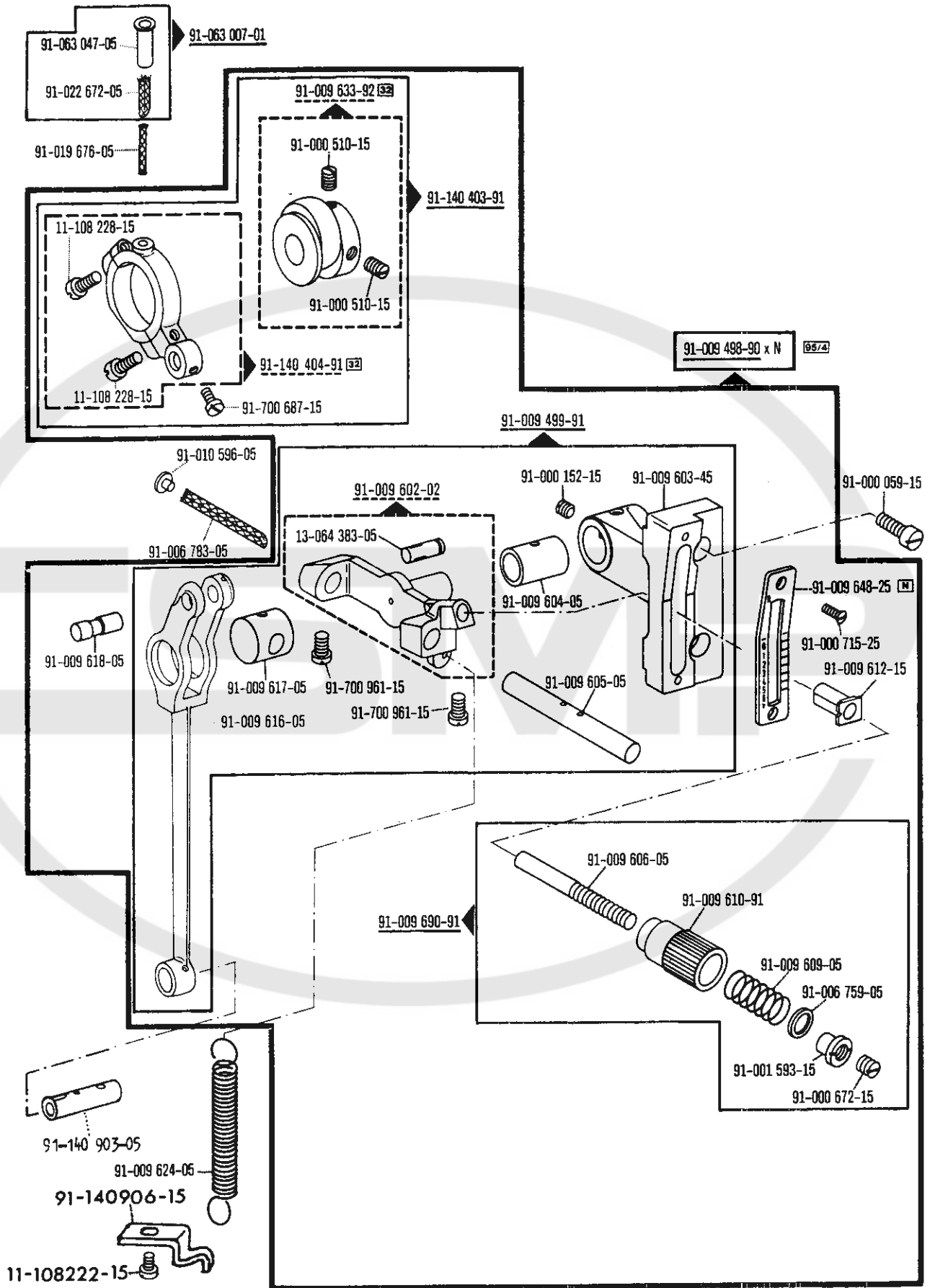

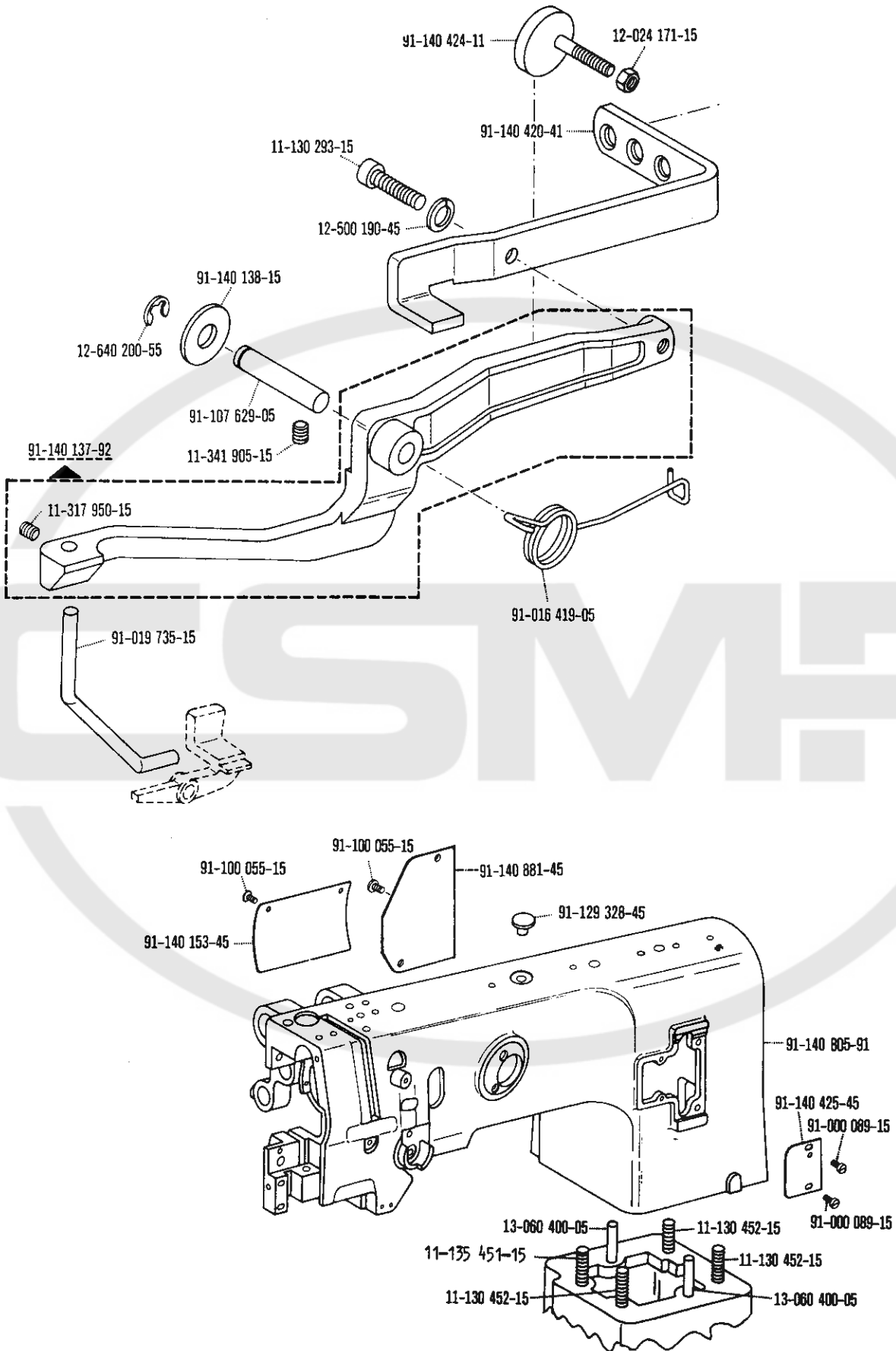

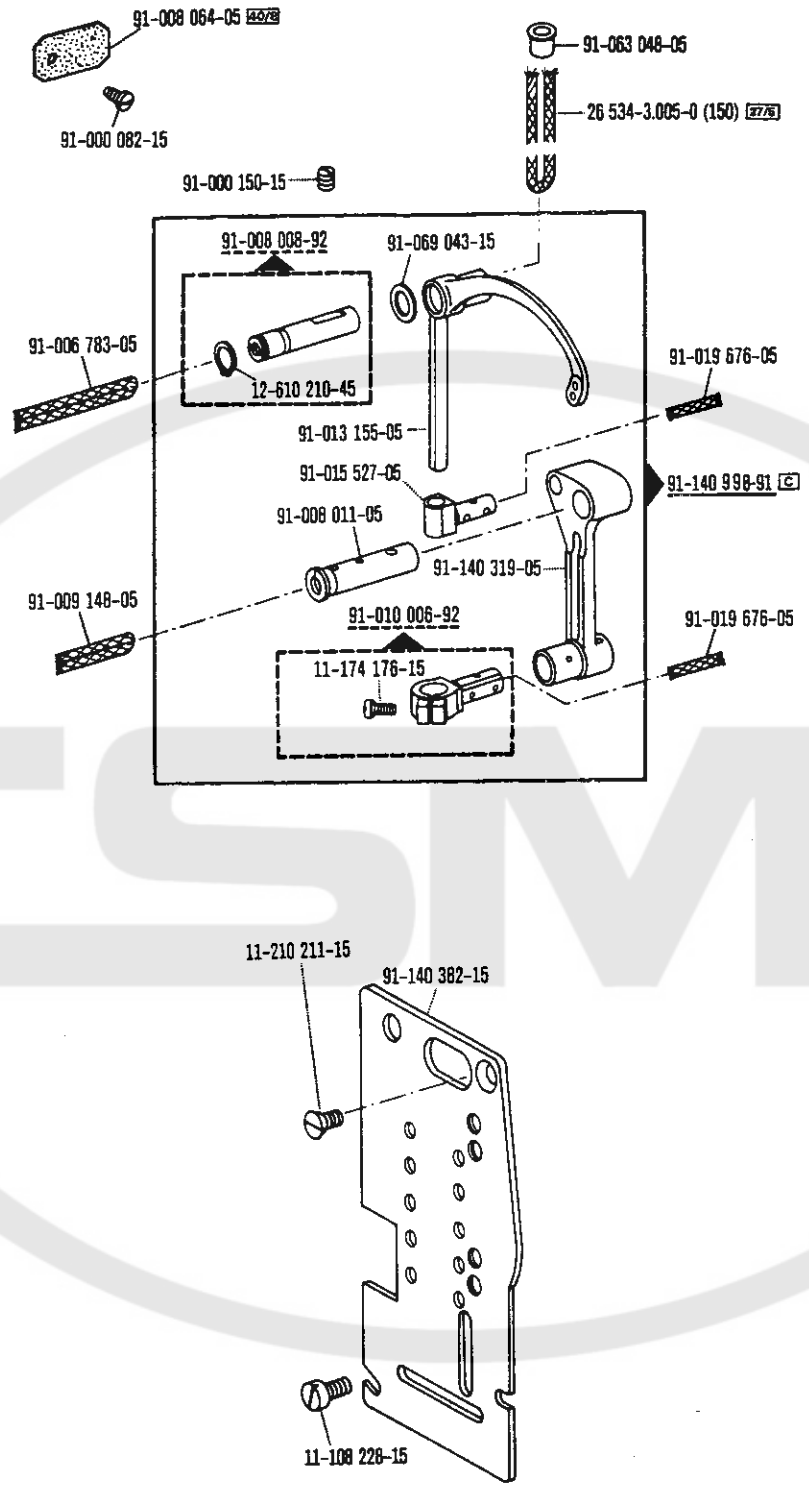

Verriegelungs-Einrichtung
Backtacking mechanism
Dispositif à points d'arrêt
Rematador

-911/15*)

Bausatz Nr.91-140799-90

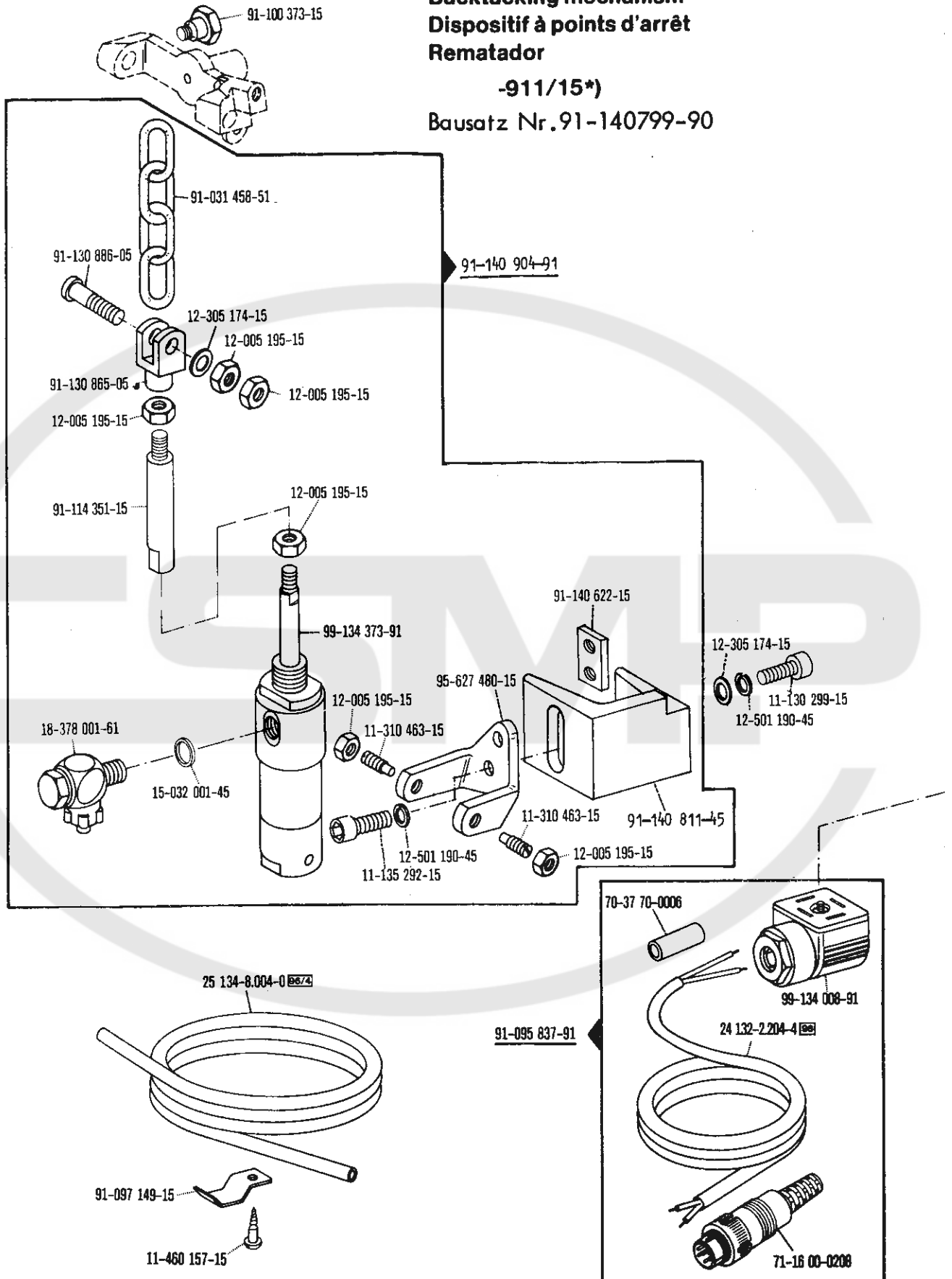

*) Beinhaltet Unterklasse -910/04
 Includes subclass -910/04
 Comprend la sous-classe -910/04

-911/15*)

Zur Wartungseinheit
For conditioning unit
Pour la conditionneur d'air comprimé
Para las require grupo acondicionador del aire

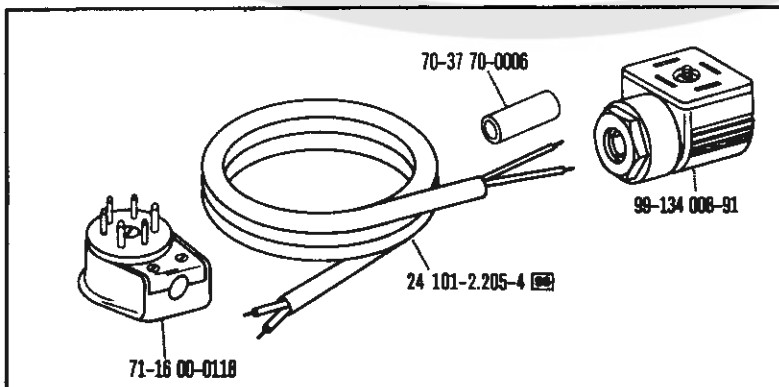
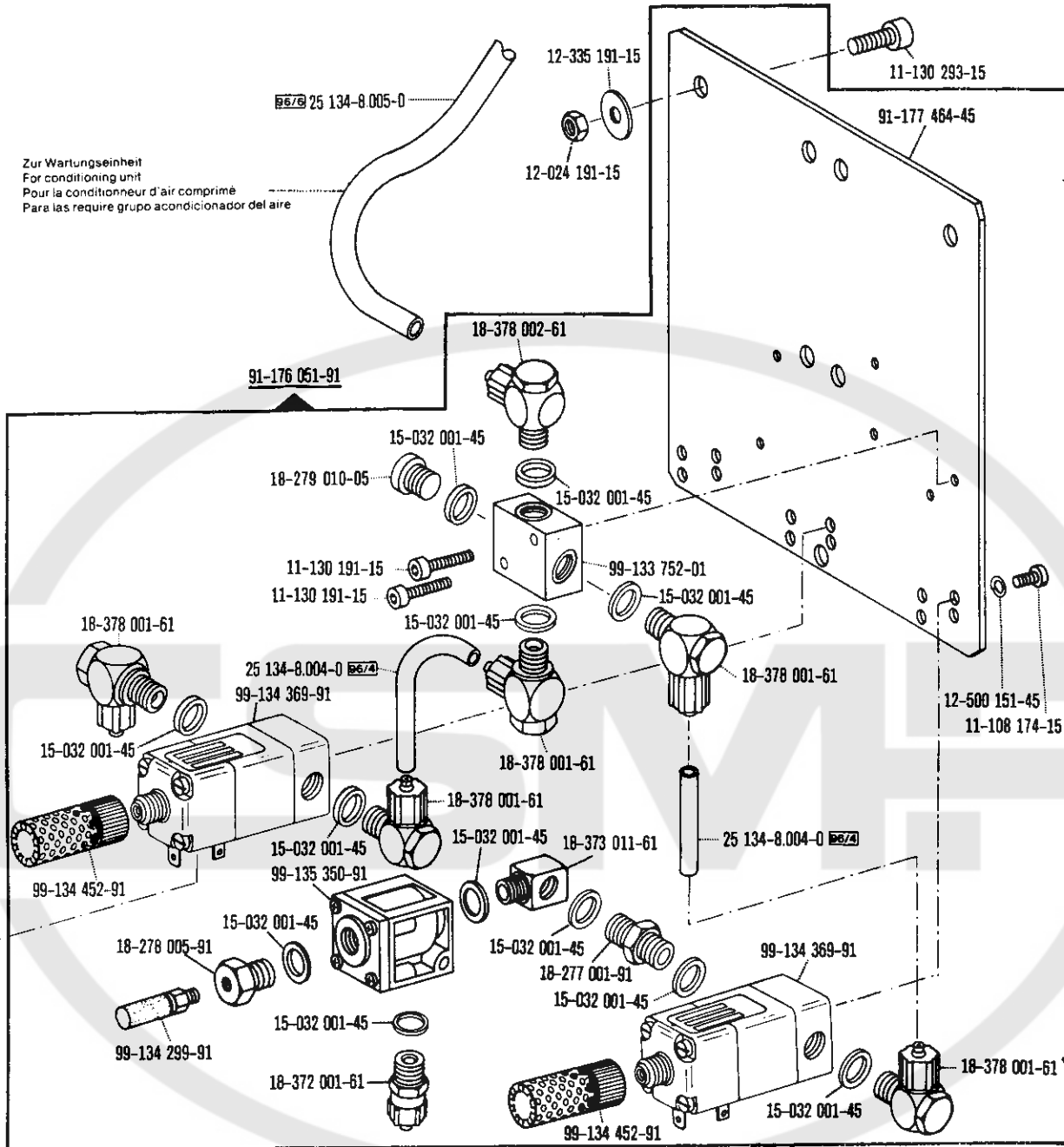

*) Beinhaltet Unterklasse -910/04
Includes subclass -910/04
Comprend la sous-classe -910/04
Comprende la subclase -910/04

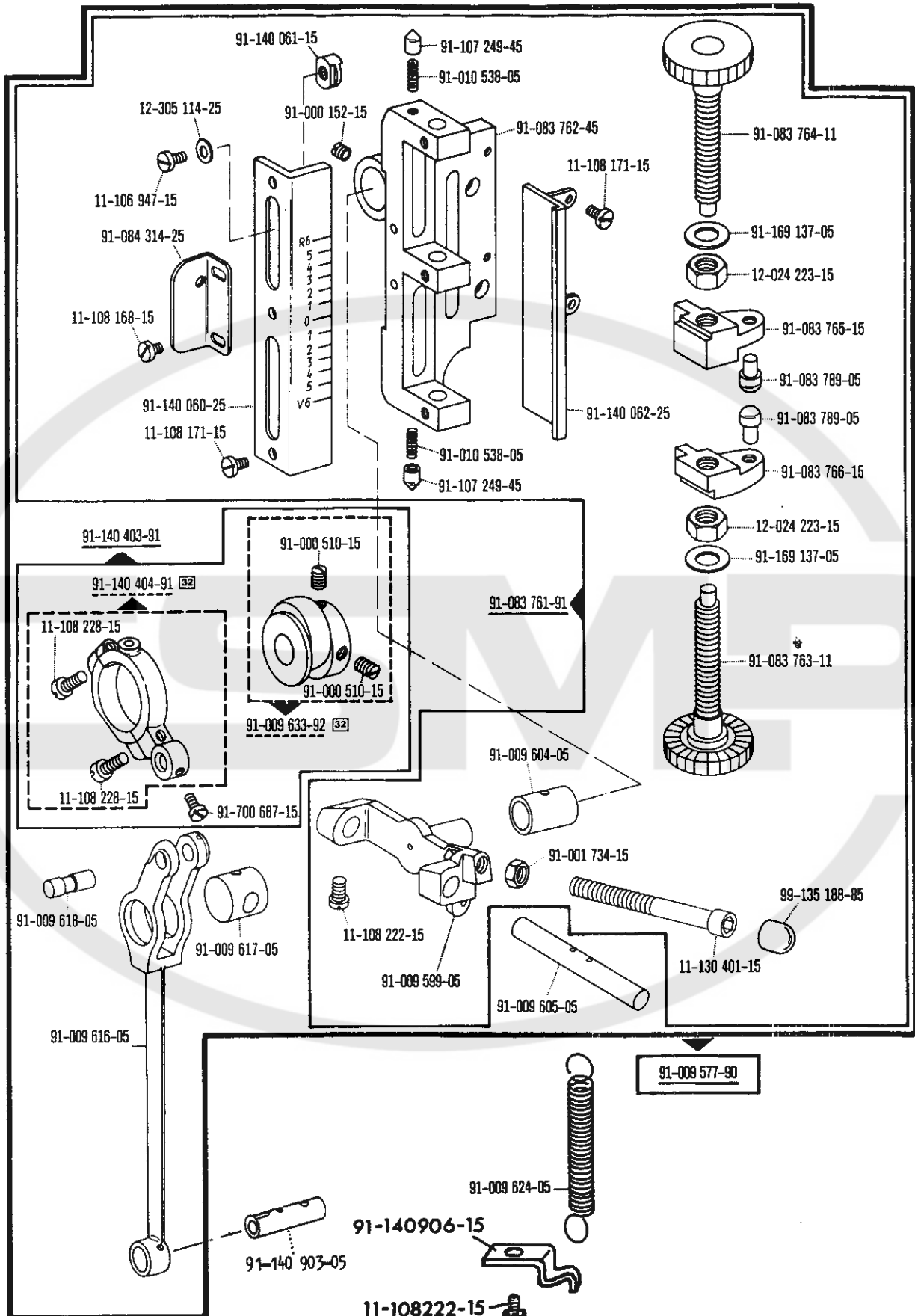

*) Beinhaltet Unterklasse -910/04
 Includes subclass -910/04
 Comprend la sous-classe -910/04
 Comprende la subclase -910/04

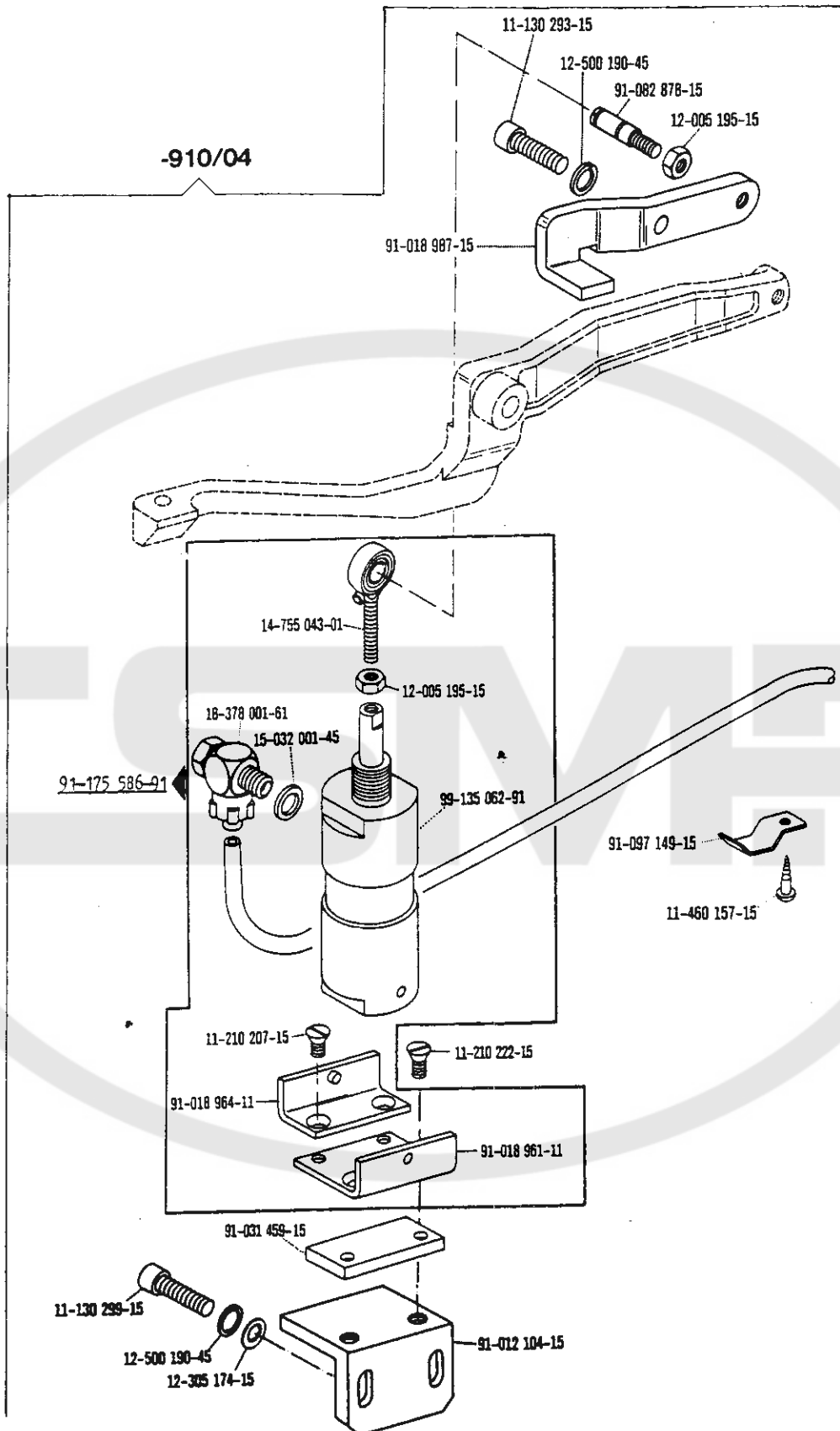

*) Beinhaltet Unterklasse -910/04
Includes subclass -910/04
Comprend la sous-classe -910/04
Comprende la subclass -910/04

5.15 Positionsgeber
Synchronizer
Synchronisateur
Sincronizador
-913/52

71-14 00-0025 (Quick B/0)
71-14 00-0029 (Quick F/0)

71-14 00-0032 (Efka P 4 - 2)

71-14 00-0031 (Kobold PI 2-3)

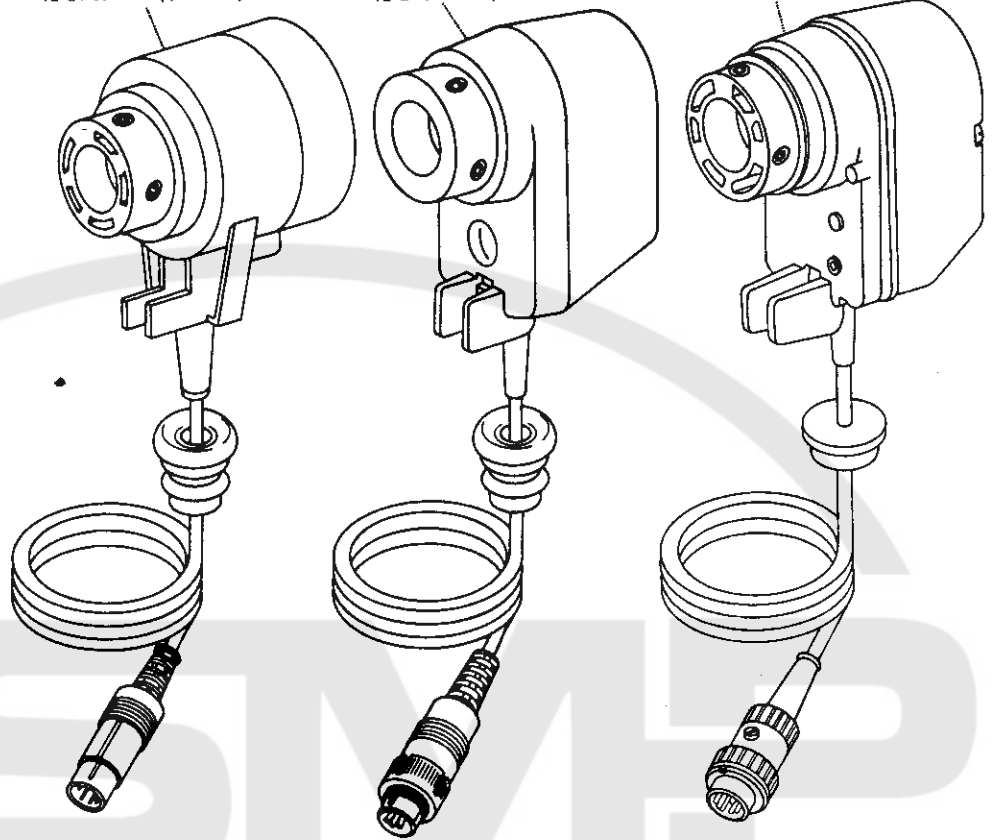
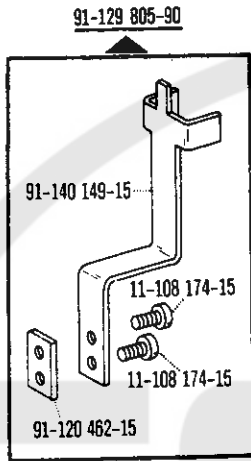

Wartungseinheit
 Air filter/lubricator
 Conditionneur d'air comprimé
 Grupo acondicionador del aire comprimido
 -925/02

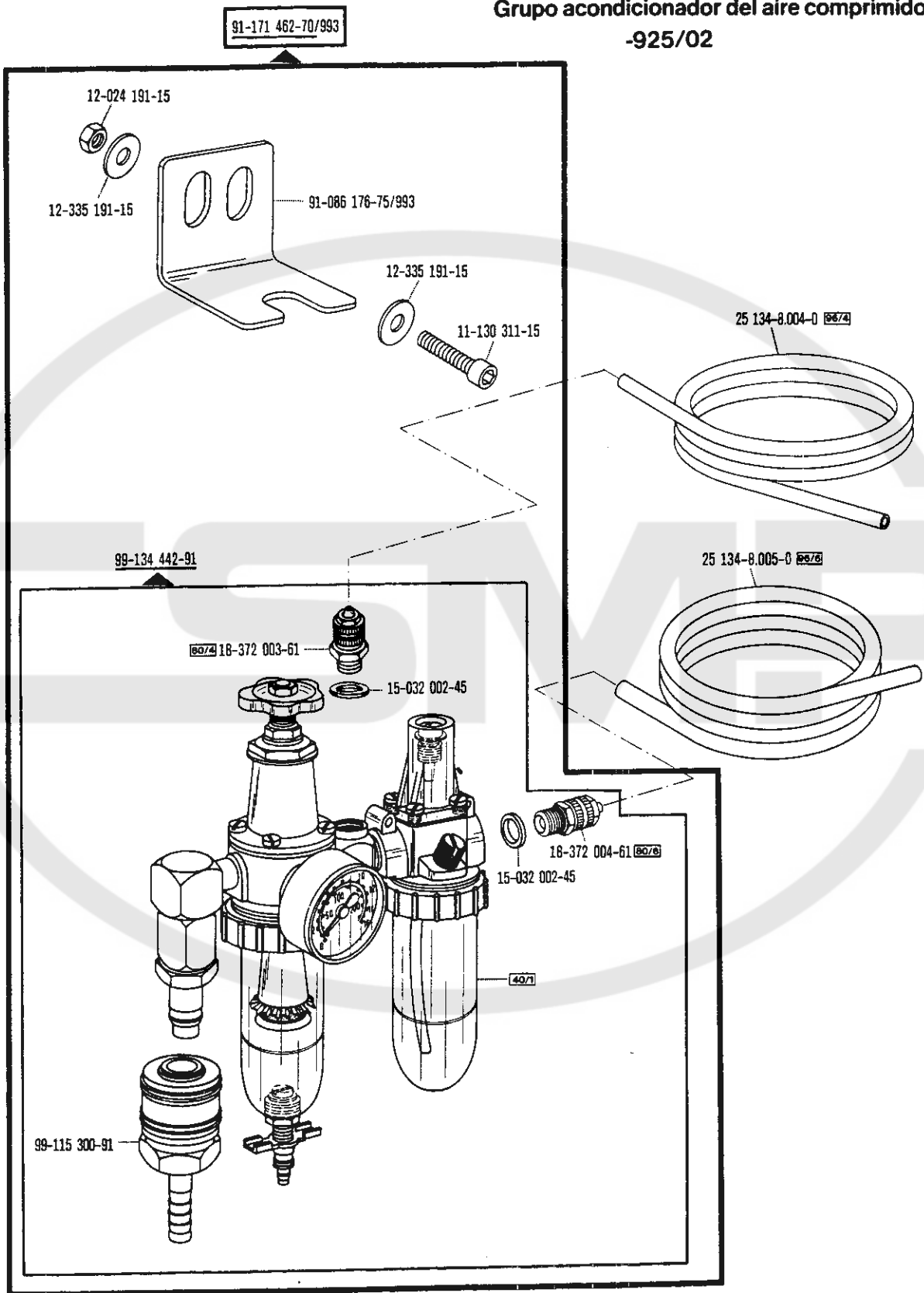

Unterklassen-Ausstattung

Subclass parts

Composition des sous-classes

Composición de las subclases



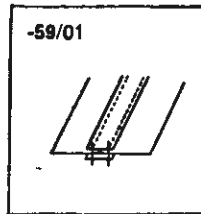

Aufnähen eines Hinterriemens auf Stiefelschäfte, bei gleichzeitigem Unternähen eines Abdeckbandes.

91-059211-04 4 10/2
10/1



91-158160-03 10/1 10/2

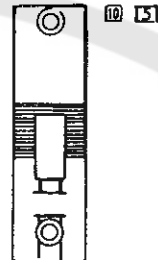

91-043455-93 4 5
10/2



91-043456-04 4 5
10/2



91-710004-93

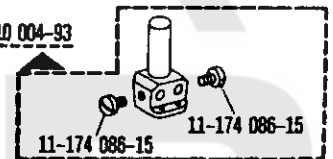

11-174086-15

11-174086-15

91-010702-91

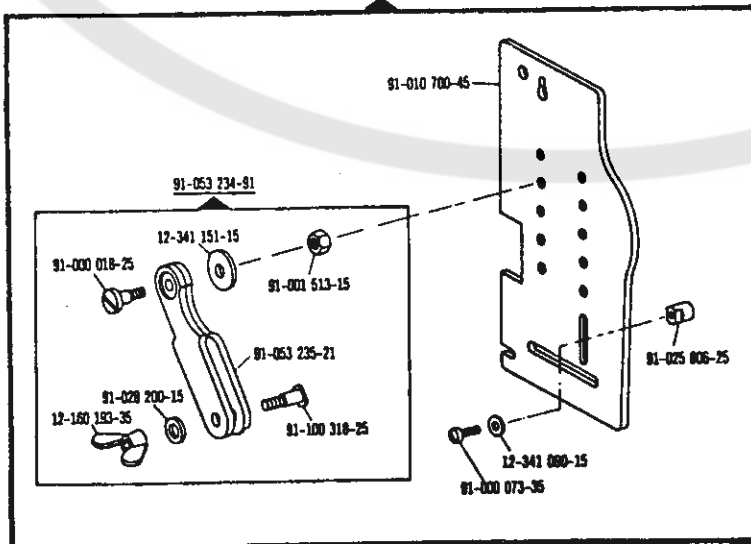

91-043408-23 5

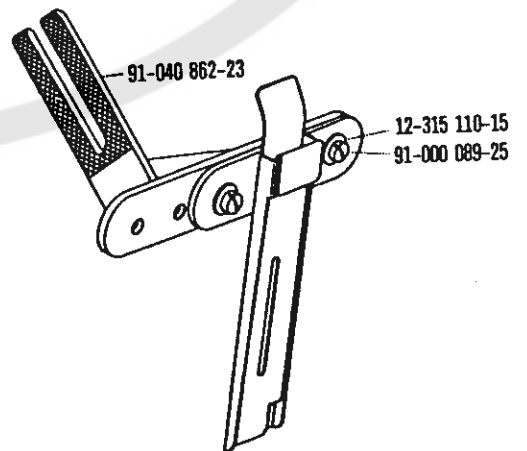

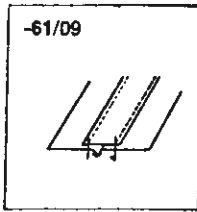

Aufnähen eines Hinterriemens auf Stiefelschäfte

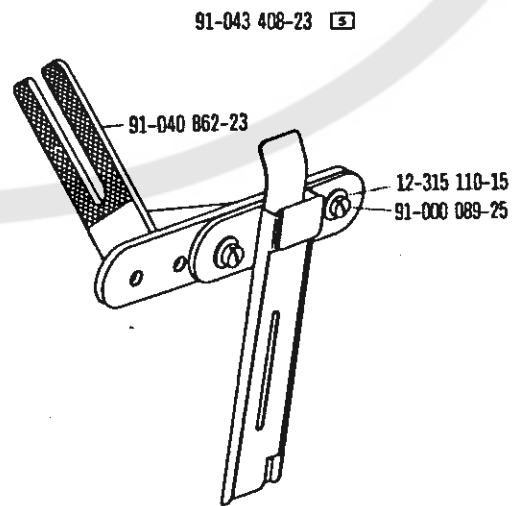
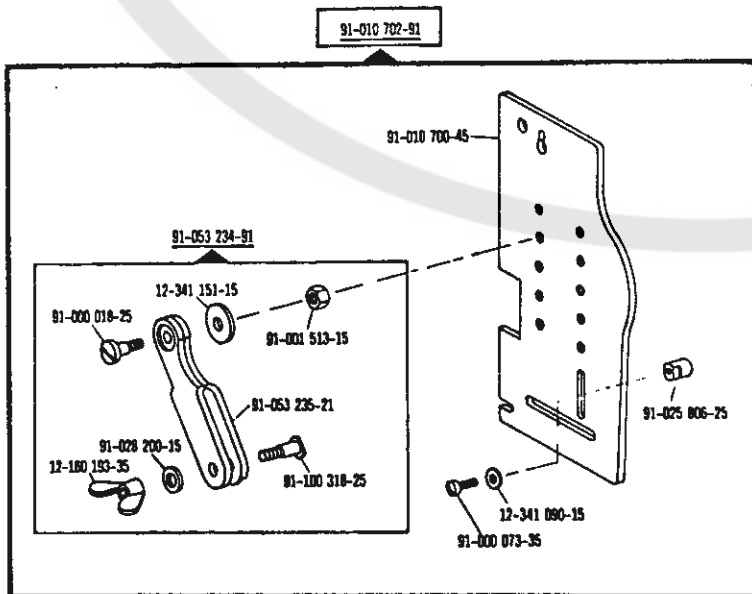
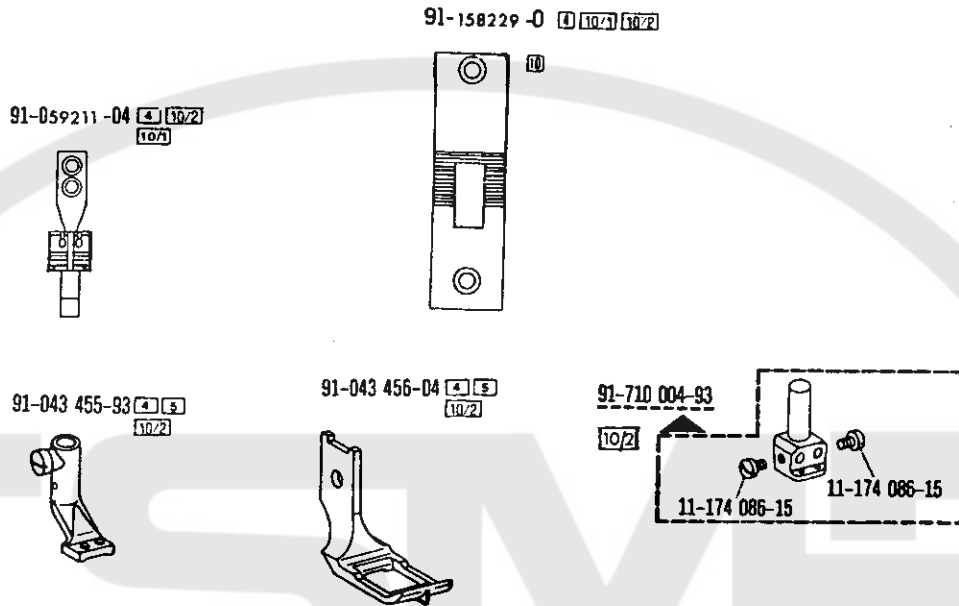

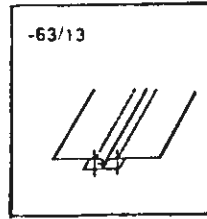

Aussteppen einer Bestechnaht an Stiefelschäften, bei gleichzeitigem Unternähen eines Abdeckbandes.

91-059211-04 4 10/2
10/2



91-158160-03 10 10/2

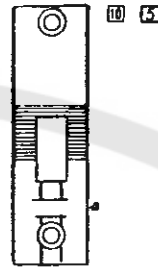

91-049 017-93 4 10/2



91-040 429-04 4 10/2



91-710 004-93

10/2

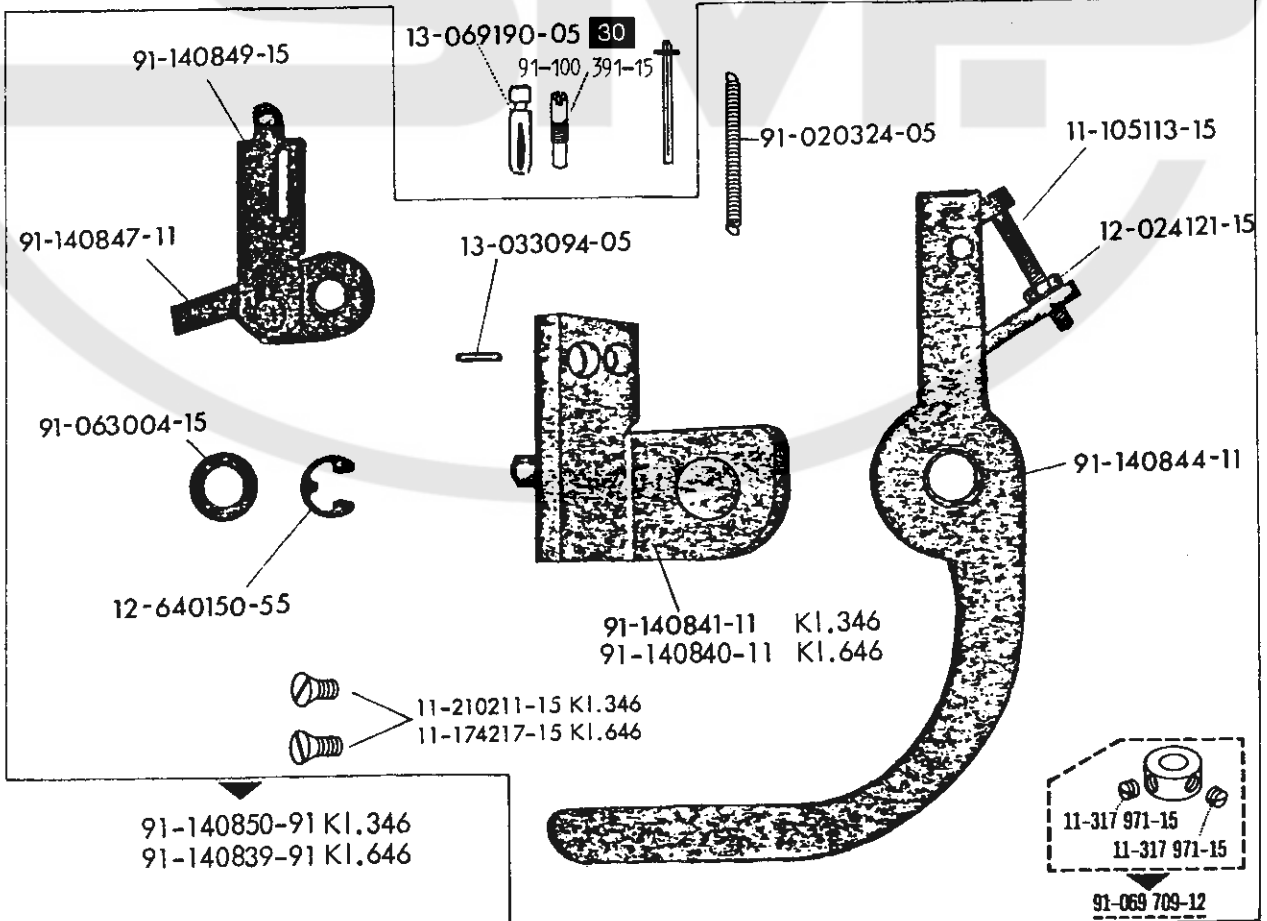
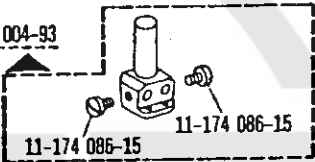

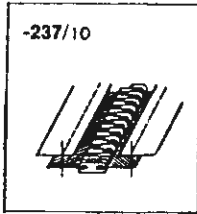

Einnähen eines Reißverschlusses in Stiefelschäfte, wobei die beiden Materialkanten nicht umgelegt werden.

91-158229-04 10/2 10/2 10/2

91-059211-04 10/2 10/2

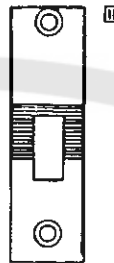

91-049 144-93 4 5



91-049 503-03 4 5 10/2

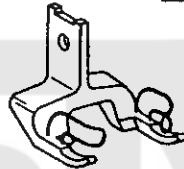

91-710 004-93 10/2

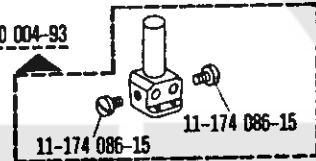

91-108 604-91

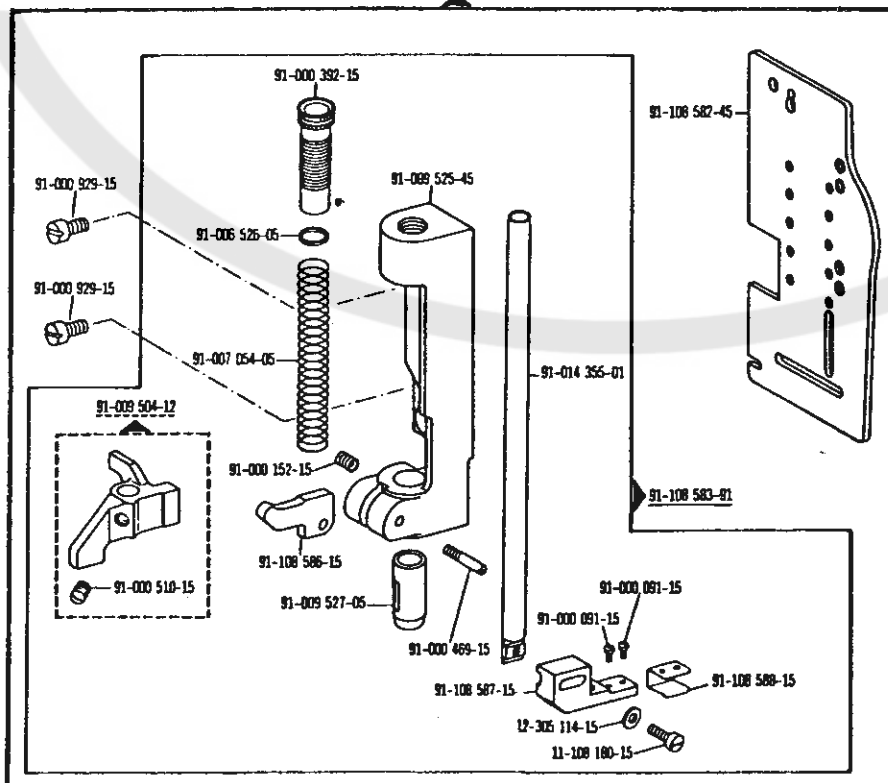

91-056 040-93 E

