

Pfaff 417

Pfaff 419

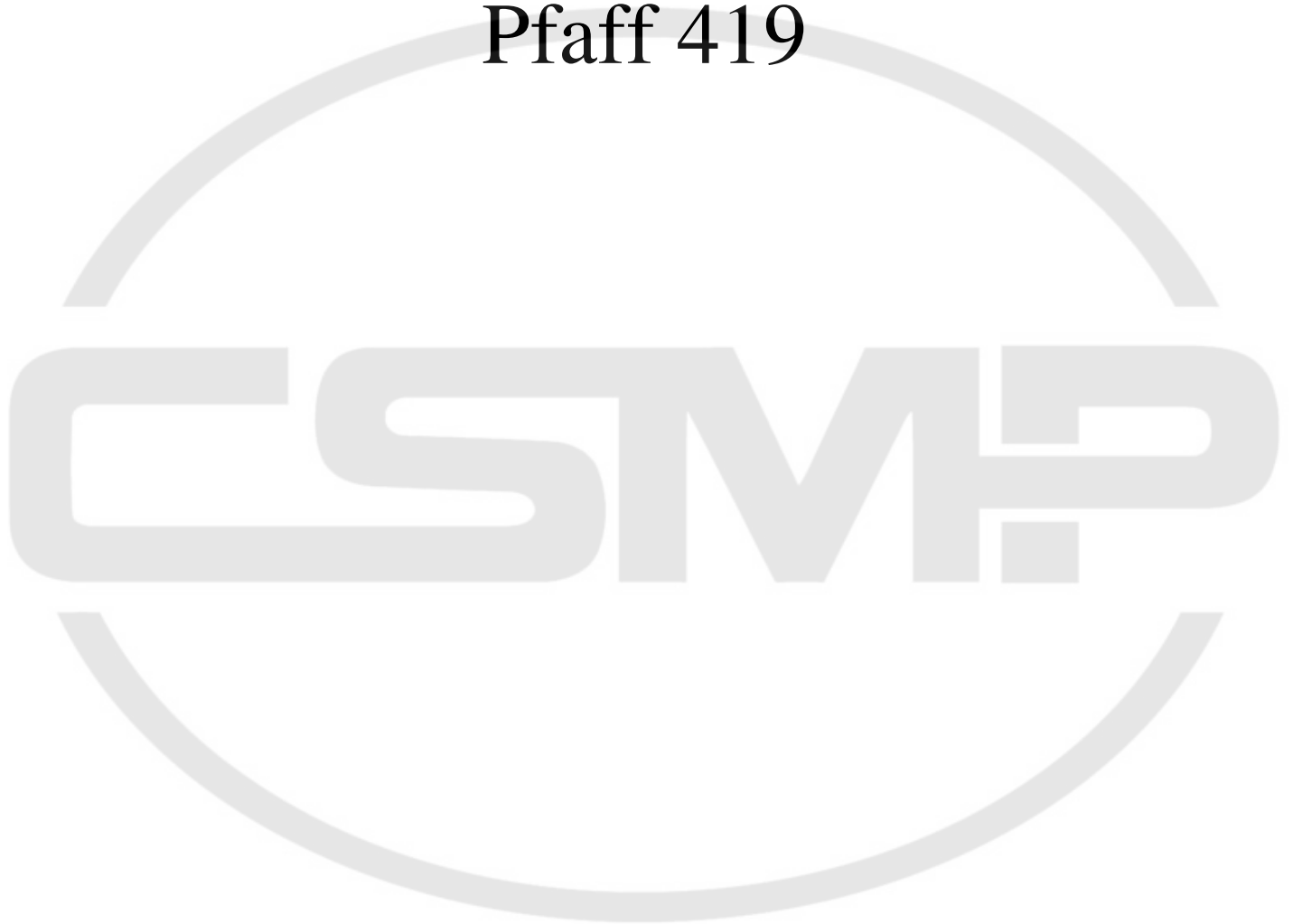

PFAFF[®] **417/419**



Bestandteileliste

List of spare parts

Liste de pièces détachées

Lista de piezas de repuesto

Die Inhaltsübersicht auf Seite 3 gibt einen Überblick über die Aufgliederung der Liste.
Die Teile sind so abgebildet, wie sie in der Maschine funktionsmäßig zusammengehören.
Die gestrichelten Abbildungen zeigen, wo die daneben abgebildeten Teile hingehören.
Die Einrahmungen auf den Bildseiten zeigen, aus welchen Einzelteilen sich die Gruppenteile zusammensetzen.

Die auf den Bildseiten verwendeten Schlüsselzeichen (□; ②; ③ usw.) sind in Register „O“ zusammengefaßt und erläutert.

Das Erstellungsdatum ist auf den einzelnen Seiten oben rechts angegeben. Bei Austausch bitte Datum beachten.

Ergänzungen und Änderungen werden durch den Änderungsdienst bekanntgegeben.
Konstruktionsänderungen vorbehalten.

For the various sections of this catalogue, please refer to the "Contents" on page 3.
The parts are illustrated as they belong together in the machine.
The dashed illustrations show where the adjacent parts belong.
The framed-in sections on the illustration pages show the individual parts comprising a group.
The reference keys (□, ②, ③ etc.) used on the illustration pages are compiled and explained in section "O".
The date of preparation of the individual pages is indicated in the upper right-hand corner. Please note the new date on revised sheets.
All alterations and modifications will be announced by special circulars.
Subject to alterations in design.

La table des matières, page 3, donne un aperçu sur la subdivision de la liste.
Les pièces figurent sur l'illustration comme elles vont ensemble.
Les figures en tirets montrent le lieu de montage des pièces figurant à côté.
Les parties encadrées sur les pages à illustration représentent les pièces individuelles formant groupe.
Les symboles (□, ②, ③ etc.) utilisés sur les pages illustrées sont regroupés et expliqués au registre „O”.
La date de parution des différentes planches est indiquée dans l'angle supérieur droit. Veiller à toujours n'utiliser que les planches les plus récentes.
Les changements seront portés à votre connaissance par l'intermédiaire de notre service de mise à jour.
Sous réserve de modifications.

En la página 3, bajo el título "contenido", puede verse un resumen de la división de la "lista de piezas".
Las piezas están ilustradas como funcionan en la máquina.
La figuras a base de líneas entrecortadas muestran dónde y cómo van montadas las piezas ilustradas al lado.
Los recuadros en las páginas ilustradas indican las piezas individuales de que se componen los grupos.
Los símbolos clave (□, ②, ③, etc.) utilizados en las páginas ilustradas se hallan recopilados y explicados en el registro „O”.
La fecha en que cada una de las páginas ha sido editada se halla indicada en la esquina derecha superior. Al reemplazar unas hojas por otras se ruega tener en cuenta la fecha.
Todo suplemento y modificación se dará a conocer a través de nuestro servicio informativo.
Salvo modificaciones técnicas.

Register Section Registre Registro		Seite Page Página
0	Erläuterungen Explanations Légende Explicaciones	5 7 9 11
1	Kopfteile Front parts Pièces de tête Piezas de la cabeza	13
2	Armteile Arm parts Pièces de bras Piezas del brazo	16
3	Grundplattenteile Bedplate parts Pièces du plateau fondamental Pieza de la placa-base	26
4	Zubehörteile Accessory parts Accessoires Accesorios	34
5	Ergänzungsteile Complementary parts Pièces complémentaires Piezas especiales	Pfaff 417/419-706/02 Pfaff 417/419-706/04 36
6	Unterklasse Subclass Sous-classe Subclase	-716/06 38
7	Unterklasse Subclass Sous-classe Subclase	-900/01 40
8	Unterklasse Subclass Sous-classe Subclase	-900/51 43
9	Fadenöler Thread lubricator Graisseur de fil Lubricador del hilo	46
10	Unterklasse Subclass Sous-classe Subclase	-909/03 47
11	Unterklasse Subclass Sous-classe Subclase	-910/01 48
12	Unterklasse Subclass Sous-classe Subclase	-910/04 50
13	Unterklasse Subclass Sous-classe Subclase	-911/03 53
14	Unterklasse Subclass Sous-classe Subclase	-911/05 56

Register Section Registre Registro		Seite Page Página
15	Unterklasse Subclass Sous-classe Subclase -911/15	59
	Unterklasse Subclass Sous-classe Subclase -911/35 = Kombination aus Combinaison of Combinación de -911/05 + -911/15	56; 59
16	Unterklasse Subclass Sous-classe Subclase -913/02	62
17	Unterklasse Subclass Sous-classe Subclase -913/03; -913/04	64
18	Unterklasse Subclass Sous-classe Subclase -913/06	65
19	Unterklasse Subclass Sous-classe Subclase -913/52	66
20	Unterklasse Subclass Sous-classe Subclase -925/01	67
21	Unterklasse Subclass Sous-classe Subclase -925/02	68
22	Unterklasse Subclass Sous-classe Subclase -925/03	69
23	Motoranschlußsatz Motor connection kit Jeu de pièces à raccorder le moteur Juego de piezas de conexión del motor (Ausrüstung mit Motordrehschalter) (equipment with motor turn switch) (avec interrupteur rotatif) (con interruptor giratorio)	70
24	Motoranschlußsatz Motor connection kit Jeu de pièces à raccorder le moteur Juego de piezas de conexión del motor (Ausrüstung mit Motorschutzschalter) (equipment with motor overload trip) (avec contacteur-disjoncteur) (con interruptor de seguridad)	72
25	Keilriemenscheiben-Tabelle Table of V-belt pulleys Tableau des poulies à gorge en V Tabla de poleas para correas en "V"	73
26	Schmiermittel-Tabelle Table of lubricants Tableau des lubrifiants Tabla de lubricantes	74
27	Nummernverzeichnis Numerical index Tableau des numéros Índice numérico	75

00-000 000-00

Hauptgruppenteil, bestehend aus: Gruppenteilen oder Gruppenteilen und Einzelteilen oder Gruppenteilen, Einzelteilen und Einzelteilen mit Ergänzung.
(Siehe Einrahmungen auf den Bildseiten.)

00-000 000-00

Gruppenteil, bestehend aus: Einzelteilen oder Einzelteilen und Einzelteilen mit Ergänzung.
(Siehe Einrahmungen auf den Bildseiten.)

00-000 000-00

Einzelteil mit Ergänzung (siehe Einrahmungen auf den Bildseiten)
z. B. Stellring mit Schrauben, Nadelstange mit Befestigungsschraube zur Nadel, usw.

00-000 000-00

Einzelteil

- Unterklassenabhängig, Teilenummer siehe separate Unterklassen-Ausstattung.
- 2 Markierung (Punkte, Striche oder Zahl) bei Bestellung angeben.
- 3 Geklebt
- 6 Nadelstärke und Spitzenform bei Bestellung angeben.
- 27/1 Eingeklammerte Zahl = Durchmesser in mm.
- 28 Sonderausführung
- 30 Frühere Ausführung, im Ersatzfall wieder bestellen.
- 30/1 Frühere Ausführung, ersetzt durch Nr. 91-167 607-01 (siehe Seite 18) und 91-068 027-05 (siehe Seite 20).
- 30/2 Frühere Ausführung, ersetzt durch Nr. 91-167 618-91 (siehe Seite 18).
- 30/3 Frühere Ausführung, ersetzt durch Nr. 91-167 799-91 (siehe Seite 18).
- 30/4 Frühere Ausführung, ersetzt durch Nr. 91-167 710-91 und 91-167 689-92 (siehe Seite 14).
- 30/6 Frühere Ausführung, Stellstange Nr. 91-168 121-05 ist kenntlich durch den alten Lagerbolzen Nr. 91-168 076-04 (siehe Seite 19), im Ersatzfall wieder bestellen.
- 30/7 Frühere Ausführung, ersetzt durch Nr. 91-100 270-15; 91-167 543-15; 91-167 544-05; 91-167 545-15; 91-167 561-05.
- 30/11 Frühere Ausführung (Länge der Zugstange = 240 mm), im Ersatzfall wieder bestellen.
- 30/12 Frühere Ausführung, ersetzt durch Nr. 91-100 339-15 und 91-174 034-05.
- 31 Einzeln nicht austauschbar, im Ersatzfall vollständiges Aggregat (eingerahmte Teile) bestellen, oder zur Reparatur einsenden.
- 32 Beim Einbau dieses Teils wird für die Paßgenauigkeit zum Anschlußteil keine Garantie übernommen; zweckmäßig vollständiges Aggregat bestellen.
- 40/1 Füllen mit Shell-Tellus 123, Bestellnummer siehe Seite 74.
- 40/2 Tränken mit Shell-Tellus 123, Bestellnummer siehe Seite 74.
- 40/3 Fetten mit Shell-Alvania 3, Bestellnummer siehe Seite 74.
- 40/4 Fetten mit Shell-Retinax G, Bestellnummer siehe Seite 74.
- 40/10 Fetten mit Molikote Longterm 00, Bestellnummer siehe Seite 74.
- 55 Stichlängenbegrenzung auf 2,5 mm.
- 61 Nähgeschwindigkeitsabhängig (für Maschinen bis 3000 Stiche/min.)

- 61/1** Nähgeschwindigkeitsabhängig (für Maschinen über 3000 Stiche/min.)
- 80/1** Für Schlauch mit 4 mm Innendurchmesser.
- 80/2** Für Schlauch mit 6 mm Innendurchmesser.
- 90/1** Für Wechselstrom
- 90/2** Für Drehstrom-
- 90/5** Zum Anschluß von Positionsgeber Quick B/T an Steuerkasten mit 4-poliger Buchse.
- 90/6** Zum Anschluß von Positionsgeber Quick B/K an Steuerkasten mit 7-poliger Buchse.
- 90/7** Langsamnäheinrichtung abschaltbar.
- 90/8** In Verbindung mit Unterklasse -910/.. Nr. 71-59 00-0237.
- 90/9** Für Motoren mit 8-stelliger Typen-Nummer.
- 90/10** Zu Nr. 91-168 121-05 in Verbindung mit Nr. 91-167 612-05 (siehe Seite 18).
- 90/11** Für Maschinen ohne -900/..
- 94/1** Bei Bestellung angeben: Kabel zu Nr. 91-095 829-91.
- 94/2** Bei Bestellung angeben: Kabel zu Nr. 91-096 747-91.
- 94/3** Bei Bestellung angeben: Kabel zu Nr. 91-095 837-91.
- 94/4** Bei Bestellung angeben: Kabel zu Nr. 91-091 331-91 und 91-091 333-91.
- 96** Länge angeben
- 96/1** Schlauch mit 6 mm Innendurchmesser, bei Bestellung Länge angeben.
- 96/2** Schlauch mit 4 mm Innendurchmesser, bei Bestellung Länge angeben.

00-000 000-00

Assembly, consisting of: sub-assemblies or
sub-assemblies and component parts or
sub-assemblies, component parts and component plus
complementary parts.
(See the framed-in sections on the illustration pages).

00-000 000-00

Sub-assembly, consisting of: component parts or
component parts and component plus complementary parts.
(See the framed-in sections on the illustration pages).

00-000 000-00

Component part with complementary parts (see the framed-in sections on the illustration pages), e.g. collar with screws, needle bar with needle set screw, etc..

00-000 000-00

Component part

- Subclass-dependent, for part number see subclass listing.
- 2** Marking (dots, strokes or numbers) to be stated on order.
- 3** Part cemented
- 6** Needle size and style of point to be stated on order.
- 27/1** Number in parentheses = Dia. in mm.
- 28** Special version
- 30** Earlier version, to be re-ordered for replacement purposes.
- 30/1** Earlier version, replaced by Nos. 91-167 607-01 (see page 18) and 91-068 027-05 (see page 20).
- 30/2** Earlier version, replaced by No. 91-167 618-91 (see page 18).
- 30/3** Earlier version, replaced by No. 91-167 799-91 (see page 18).
- 30/4** Earlier version, replaced by Nos. 91-167 710-91 and 91-167 689-92 (see page 14).
- 30/6** Earlier version of connecting rod No. 91-168 121-05 is identified by the old-type fulcrum stud No. 91-168 076-04 (see page 19), to be re-ordered for replacement purposes.
- 30/7** Earlier version, replaced by Nos. 91-100 270-15; 91-167 543-15; 91-167 544-05; 91-167 545-15; 91-167 561-05.
- 30/11** Earlier version (240 mm in length), to be re-ordered for replacement purposes.
- 30/12** Earlier version, replaced by Nos. 91-100 339-15 and 91-174 034-05.
- 31** Cannot be exchanged singly; if defective, order complete assembly (boxed-in parts) or return same for repair.
- 32** For the fitting of this part no guarantee is accepted for accuracy of tolerance with the corresponding part. It is advisable to order a complete assembly.
- 40/1** Top up with Shell-Tellus 123, Ordering No. see page 74.
- 40/2** Soak with Shell-Tellus 123, Ordering No. see page 74.
- 40/3** Grease with Shell-Alvania 3, Ordering No. see page 74.
- 40/4** Grease with Shell Retinax G, Ordering No. see page 74.
- 40/10** Grease with Molikote Longterm 00, Ordering No. see page 74.
- 55** For limiting the stitch width to 2.5 mm.
- 61** Sewing-speed-dependent (for machines up to 3000 s.p.m.)

- 61/1** Sewing-speed-dependent (for machines exceeding 3000 s. p. m.)
- 80/1** For tube with 4 mm inside diameter.
- 80/2** For tube with 6 mm inside diameter.
- 90/1** For single-phase A.C.
- 90/2** For three-phase A.C.
- 90/5** For connecting Quick synchronizer B/T to control box, with 4-pin plug.
- 90/6** For connecting Quick synchronizer B/K to control box, with 7-pin plug.
- 90/7** Inching device disengageable.
- 90/8** In conjunction with subclass -910/.. No. 71-59 00-0237.
- 90/9** For motors with 8-digit model number.
- 90/10** For No. 91-168 121-05 in conjunction with No. 91-167 612-05 (see page 18).
- 90/11** For machines without -900/..
- 94/1** To be specified on order: Lead for No. 91-095 829-91.
- 94/2** To be specified on order: Lead for No. 91-096 747-91.
- 94/3** To be specified on order: Lead for No. 91-095 837-91.
- 94/4** To be specified on order: Lead for Nos. 91-091 331-91 and 91-091 333-91.
- 96** State length
 - 96/1** Tube with 6 mm inside dia.; state length on order.
 - 96/2** Tube with 4 mm inside dia.; state length on order.

00-000 000-00

Groupe principal de pièces, comprenant: des groupes de pièces ou des groupes de pièces et des pièces détachées ou des groupes de pièces, des pièces détachées et des pièces détachées avec des pièces complémentaires (Voir parties encadrées sur illustrations).

00-000 000-00

Groupe de pièces, comprenant: des pièces détachées ou des pièces détachées et des pièces détachées avec pièces complémentaires (Voir parties encadrées sur illustrations).

00-000 000-00

Pièce détachée avec pièces complémentaires (Voir parties encadrées sur illustrations).
Par exemple, bague avec vis, barre à aiguille avec vis de fixation d'aiguille, etc.

00-000 000-00

Pièce détachée

- Fonction de la sous-classe, pour le numéro de la pièce, voir équipement de sous-classes.
- 2 Préciser les repères (points, traits ou chiffres) à la commande.
- 3 Pièce collée
- 6 Préciser la grosseur de l'aiguille et la forme de la pointe à la commande.
- 27/1 Chiffre entre parenthèses = Diamètre en mm.
- 28 Version spéciale
- 30 Ancienne version, à commander à nouveau pour échange.
- 30/1 Ancienne version, remplacée par nos 91-167 607-01 (voir page 18) et 91-068 027-05 (voir page 20).
- 30/2 Ancienne version, remplacée par n° 91-167 618-91 (voir page 18).
- 30/3 Ancienne version, remplacée par n° 91-167 799-91 (voir page 18).
- 30/4 Ancienne version, remplacée par nos 91-167 710-91 et 91-167 689-92 (voir page 14).
- 30/6 Ancienne version, bielle de réglage 91-168 121-05, caractérisée par l'ancien boulon n° 91-168 076-04 (voir page 19), à commander à nouveau pour échange.
- 30/7 Ancienne version, remplacée par nos 91-100 270-15; 91-167 543-15; 91-167 544-05; 91-167 545-15; 91-167 561-05.
- 30/11 Version ancienne (240 mm de long), à recommander en cas de besoin.
- 30/12 Ancienne version, remplacée par nos 91-100 339-15 et 91-174 034-05.
- 31 Pièces seules non interchangeables, si nécessaire, commander élément complet (encadré) ou le renvoyer pour réparation.
- 32 Aucune garantie ne pourra être assurée quant à la précision d'ajustage de cette pièce avec la pièce correspondante; il est indiqué de commander un mécanisme complet.
- 40/1 Remplir avec de l'huile Shell-Tellus 123: n° de commande voir page 74.
- 40/2 Imbiber avec de l'huile Shell-Tellus 123: n° de commande voir page 74.
- 40/3 Graisser avec de la graisse Shell-Alvania 3: n° de commande voir page 74.
- 40/4 Graisser avec de la graisse Shell-Retinax G: n° de commande voir page 74.
- 40/10 Graisser avec de la graisse Mollkote Longterm 00: n° de commande voir page 74.
- 55 Pour limiter la longueur du point à 2,5 mm.
- 61 Fonction de la vitesse de couture (machines à vitesse maximale inférieure à 3.000 pts/mn.).

- 61/1** Fonction de la vitesse de couture (machines à vitesse maximale supérieure à 3.000 pts/mn.).
- 80/1** Pour tuyau de 4 mm de diamètre intérieur.
- 80/2** Pour tuyau de 6 mm de diamètre intérieur.
- 90/1** Pour du courant alternatif.
- 90/2** Pour du courant triphasé.
- 90/5** Pour raccorder le synchronisateur Quick B/T sur la boîte de contrôle à prise à 4 pôles.
- 90/6** Pour raccorder le synchronisateur Quick B/K sur la boîte de contrôle à prise à 7 pôles.
- 90/7** Réducteur de vitesse, débrayable.
- 90/8** En liaison avec la sous-classe -910/.. n° 71-59 00-0237.
- 90/9** Pour moteurs à référence de modèle à 8 chiffres.
- 90/10** Pour n° 91-168 121-05 en liaison avec le n° 91-167 612-05 (voir page 18).
- 90/11** Pour machines sans -900/..
- 94/1** A préciser à la commande: fil pour n° 91-095 829-91.
- 94/2** A préciser à la commande: fil pour n° 91-096 747-91.
- 94/3** A préciser à la commande: fil pour n° 91-095 837-91.
- 94/4** A préciser à la commande: fil pour nos 91-091 331-91 et 91-091 333-91.
- 96** Préciser la longueur.
- 96/1** Tuyau de 6 mm de diamètre intérieur; préciser la longueur.
- 96/2** Tuyau de 4 mm de diamètre intérieur; préciser la longueur.

00-000 000-00

Grupo principal de piezas, compuesto de: subgrupo de piezas o subgrupo de piezas y piezas individuales o subgrupo de piezas, piezas individuales y piezas complementarias (véase el índice numérico).

00-000 000-00

Subgrupo de piezas, compuesto de: piezas individuales o piezas individuales y piezas complementarias (véase el índice numérico).

00-000 000-00

Pieza individual con pieza complementaria (véase índice numérico).
Por ejemplo: anillo de ajuste con tornillo, barra de aguja con tornillo de fijación para la aguja, etc.

00-000 000-00

Pieza individual.

- Dependientes de la subclase, para el Nº de pieza véase „Dotación de subclases”.
- 2 Señales (puntos, rayas o cifras), indiquense en los pedidos.
- 3 Pieza pegada
- 6 Grosor de aguja y forma de la punta, indiquese en los pedidos.
- 27/1 Cifra entre paréntesis = Diámetro en mm.
- 28 Tipo especial.
- 30 Tipo anterior, en caso de sustitución pidase de nuevo.
- 30/1 Tipo anterior, se sustituye por el Nº 91-167 607-01 (véase la página 18) y 91-068 027-05 (véase la página 20).
- 30/2 Tipo anterior, se sustituye por el Nº 91-167 618-91 (véase la página 18).
- 30/3 Tipo anterior, se sustituye por el Nº 91-167 799-91 (véase la página 18).
- 30/4 Tipo anterior, se sustituye por el Nº 91-167 710-91 y 91-167 689-92 (véase la página 14).
- 30/6 Tipo anterior, la barra de ajuste Nº 91-168 121-05 es reconocible por el perno de apoyo antiguo Nº 91-168 076-04 (véase la página 19), en caso de sustitución pidase de nuevo.
- 30/7 Tipo anterior, se sustituye por los números 91-100 270-15; 91-167 543-15; 91-167 544-05; 91-167 545-15; 91-167 561-05.
- 30/11 Tipo anterior (240 mm de largo), en caso de sustitución pidase de nuevo.
- 30/12 Tipo anterior, se sustituye por el Nº 91-100 339-15 y 91-174 034-05.
- 31 No es recambiable individualmente, en caso de sustitución pidase el agregado completo (pieza enmarcada), o envíese para su reparación.
- 32 Al montar esta pieza no se asume garantía alguna en cuanto a la tolerancia y precisión de ajuste respecto a la pieza correspondiente; por esta razón se recomienda pedir el grupo completo.
- 40/1 Rellene con aceite Shell-Tellus 123, para el Nº de pedido véase la página 74.
- 40/2 Empape con aceite Shell-Tellus 123, para el Nº de pedido véase la página 74.
- 40/3 Engrase con grasa Shell-Alvania 3, para el Nº de pedido véase la página 74.
- 40/4 Engrase con grasa Shell-Retinax G, para el Nº de pedido véase la página 74.
- 40/10 Engrase con grasa Molikote Longterm 00, para el Nº de pedido véase la página 74.
- 55 Limitación del largo de puntada a 2,5 mm.
- 61 Dependiente de la velocidad de costura (para máquinas de hasta 3000 punt/min).

- 61/1** Dependiente de la velocidad de costura (para máquinas de más de 3000 punt/min).
- 80/1** Para tubo de plástico de 4 mm de diámetro interior.
- 80/2** Para tubo de plástico de 6 mm de diámetro interior.
- 90/1** Para corriente alterna.
- 90/2** Para corriente trifásica.
- 90/5** Para conectar el posicionador Quick B/T a la caja de mandos con enchufe de 4 polos.
- 90/6** Para conectar el posicionador Quick B/K a la caja de mandos con enchufe de 7 polos.
- 90/7** Dispositivo para costura lenta, desconectable.
- 90/8** En combinación con la subclase -910/.. № 71-59 00-0237.
- 90/9** Para motores con referencia de modelo de 8 cifras.
- 90/10** Para el № 91-168 121-05 en combinación con 91-167 612-05 (véase la página 18).
- 90/11** Para máquinas sin -900/..
- 94/1** Indíquese en los pedidos: cable para el № 91-095 829-91.
- 94/2** Indíquese en los pedidos: cable para el № 91-096 747-91.
- 94/3** Indíquese en los pedidos: cable para el № 91-095 837-91.
- 94/4** Indíquese en los pedidos: cable para el № 91-091 331-91 y 91-091 333-91.
- 96** Indíquese la largura.
- 96/1** Tubo de 6 mm de diámetro interior; indíquese la largura.
- 96/2** Tubo de 4 mm de diámetro interior; indíquese la largura.

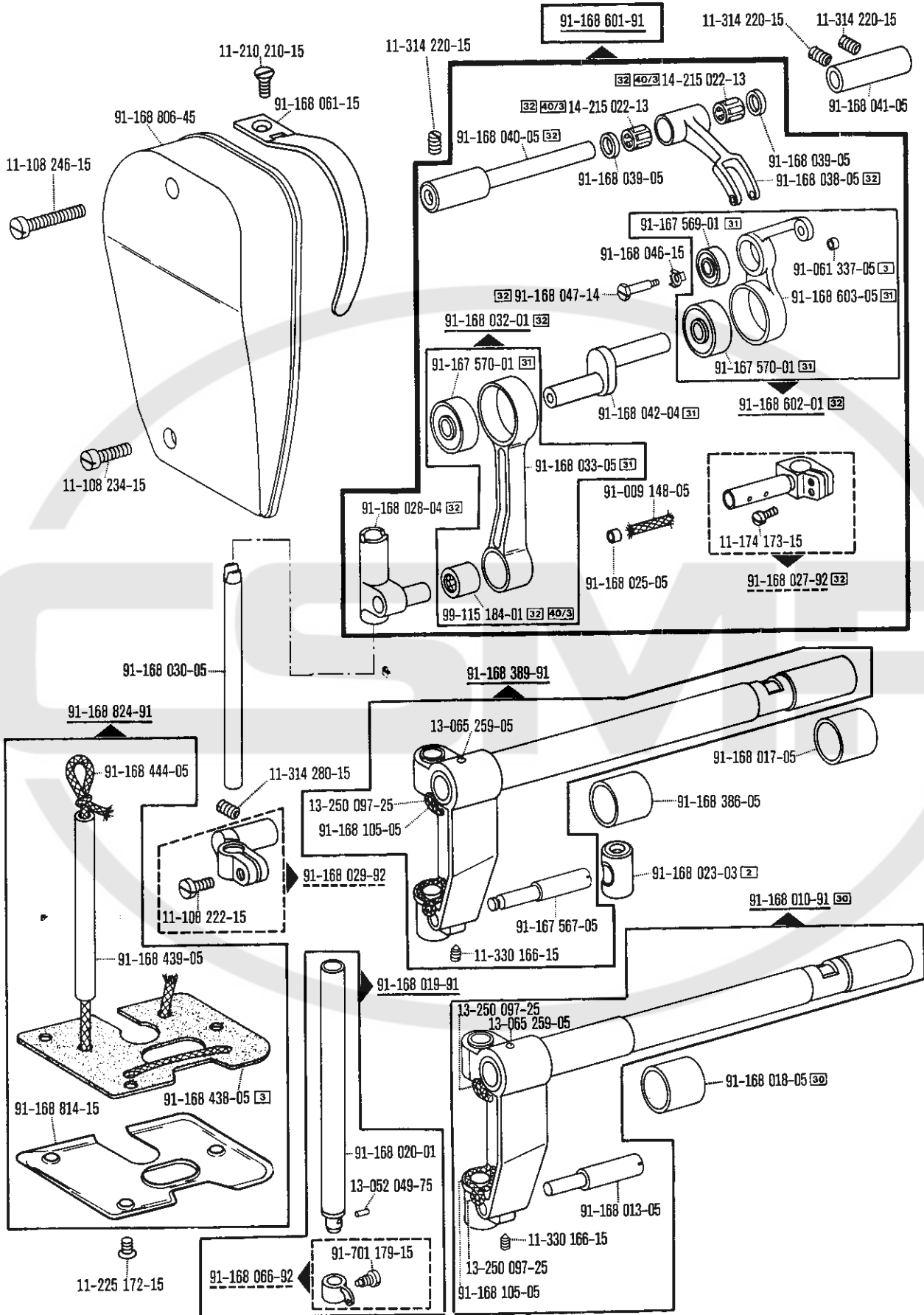

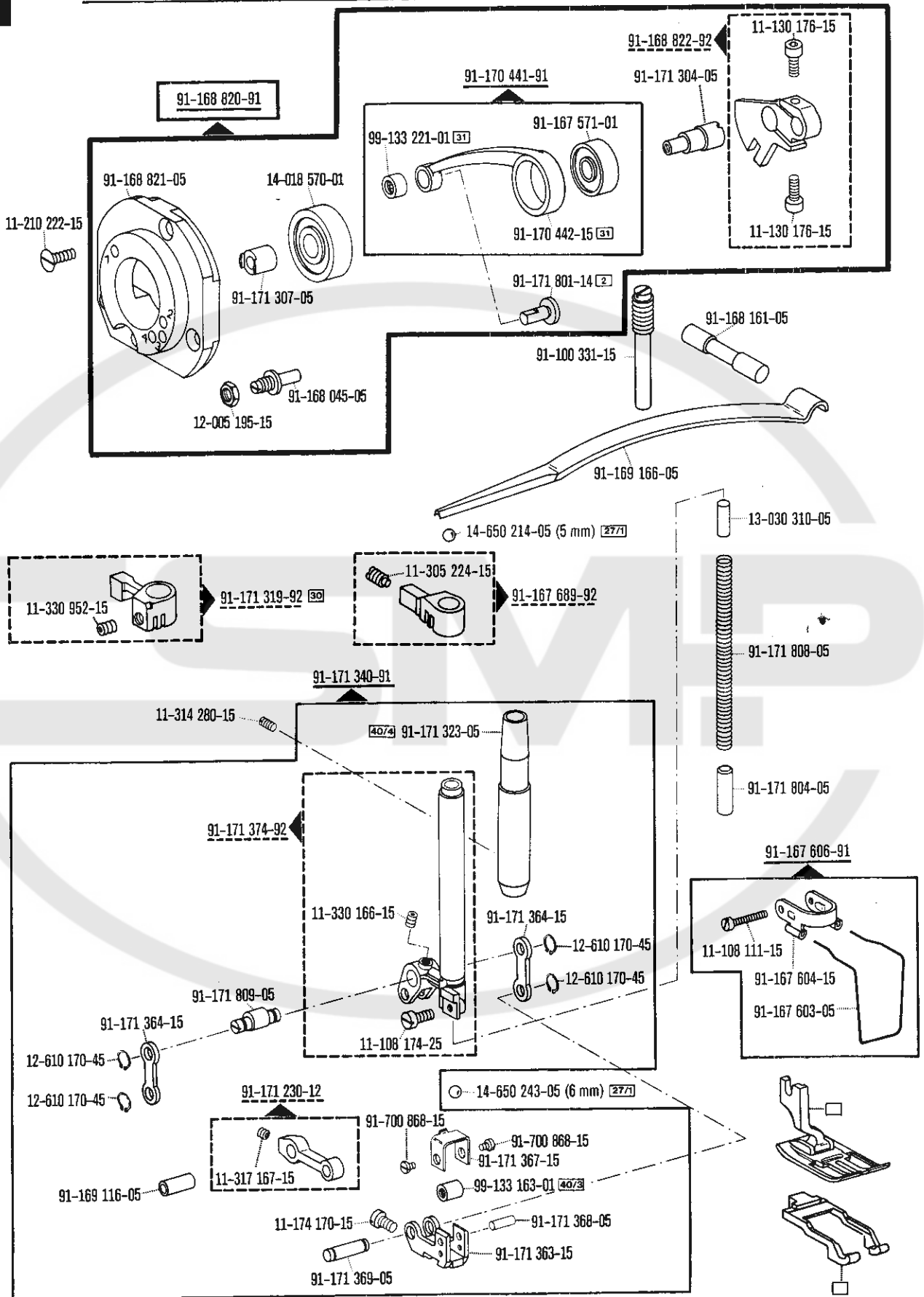

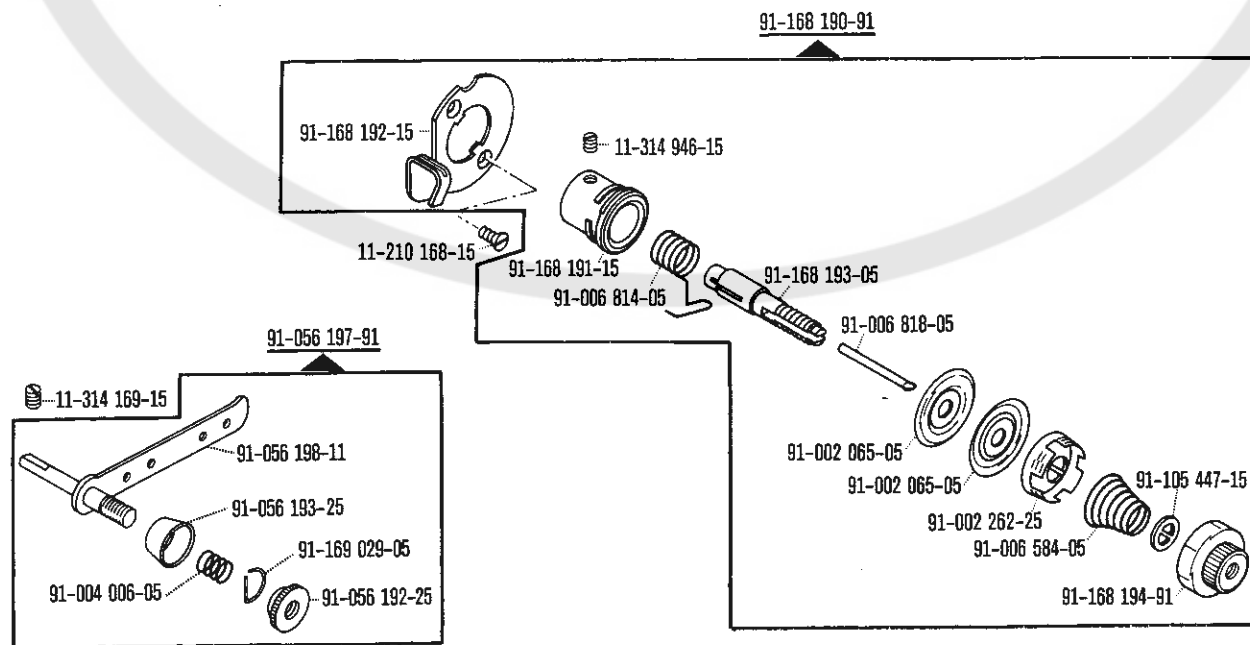
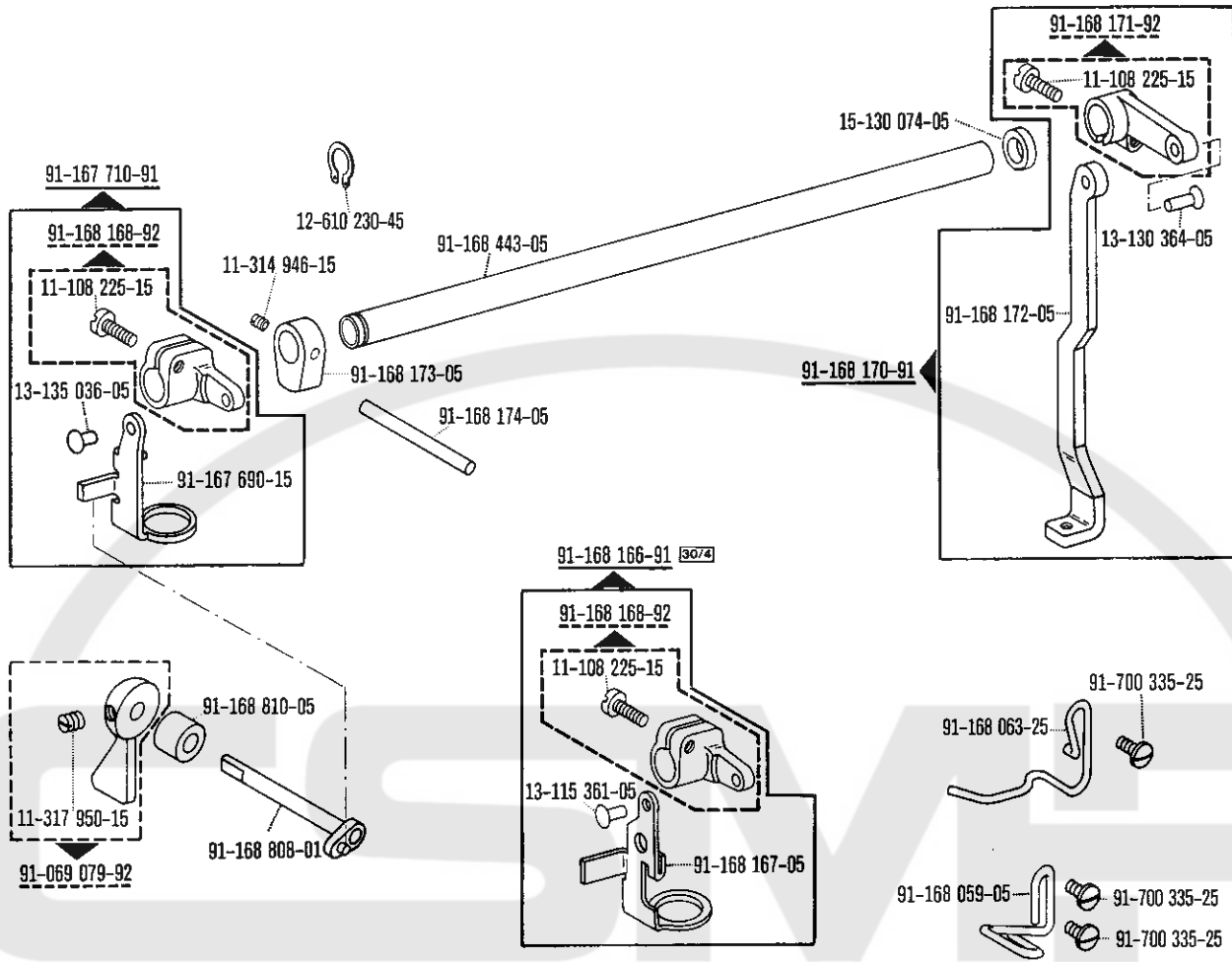

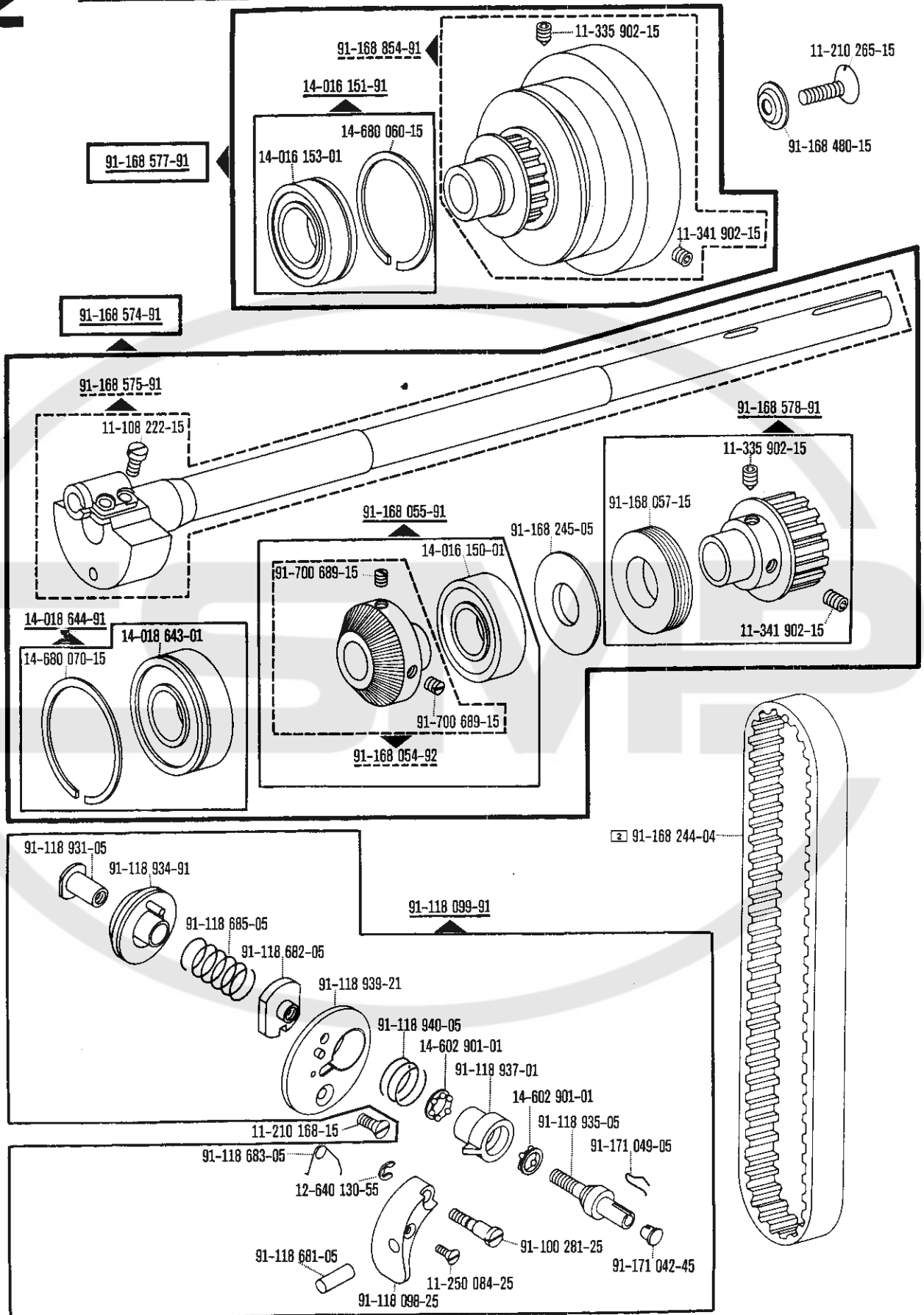

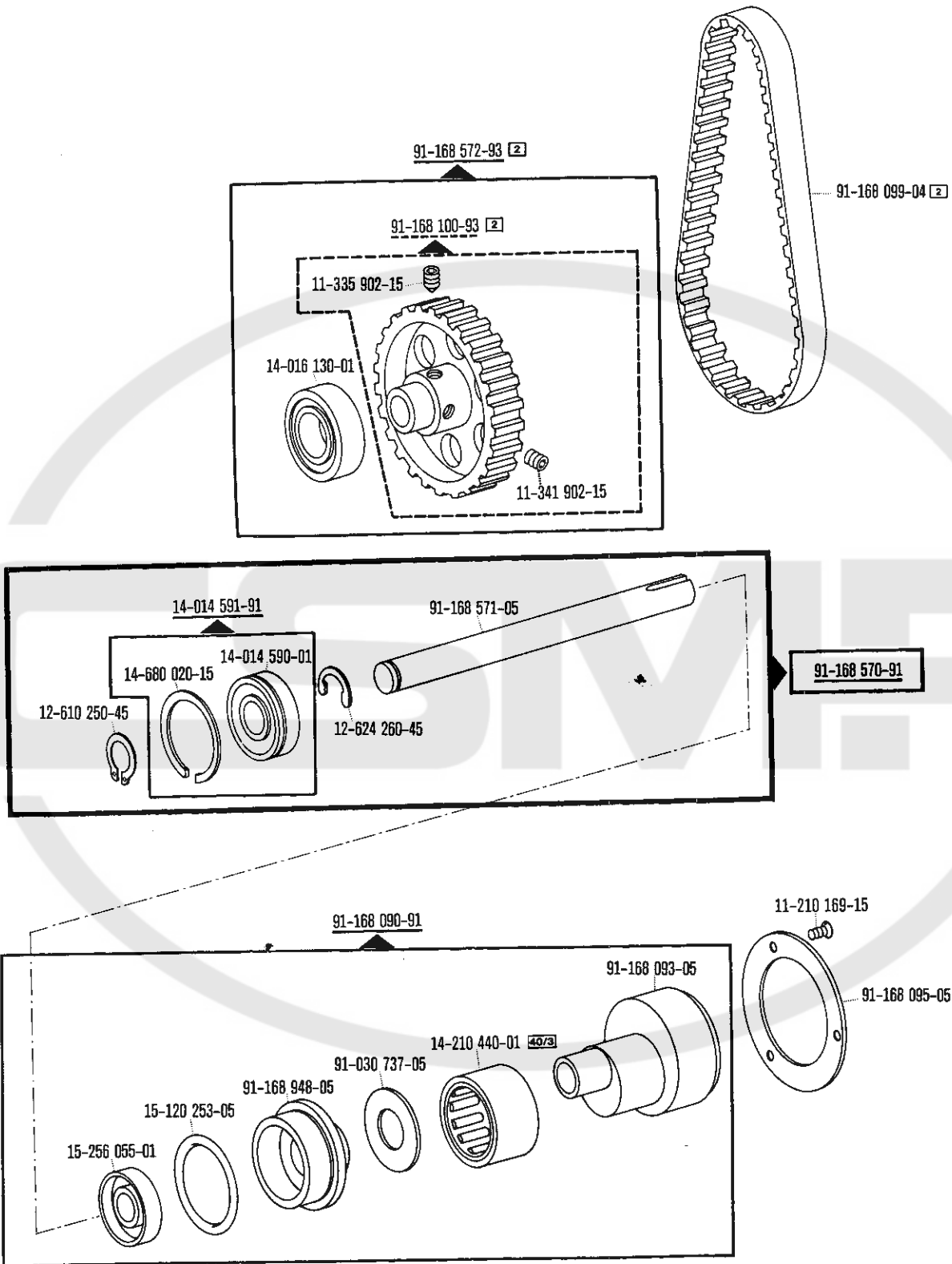

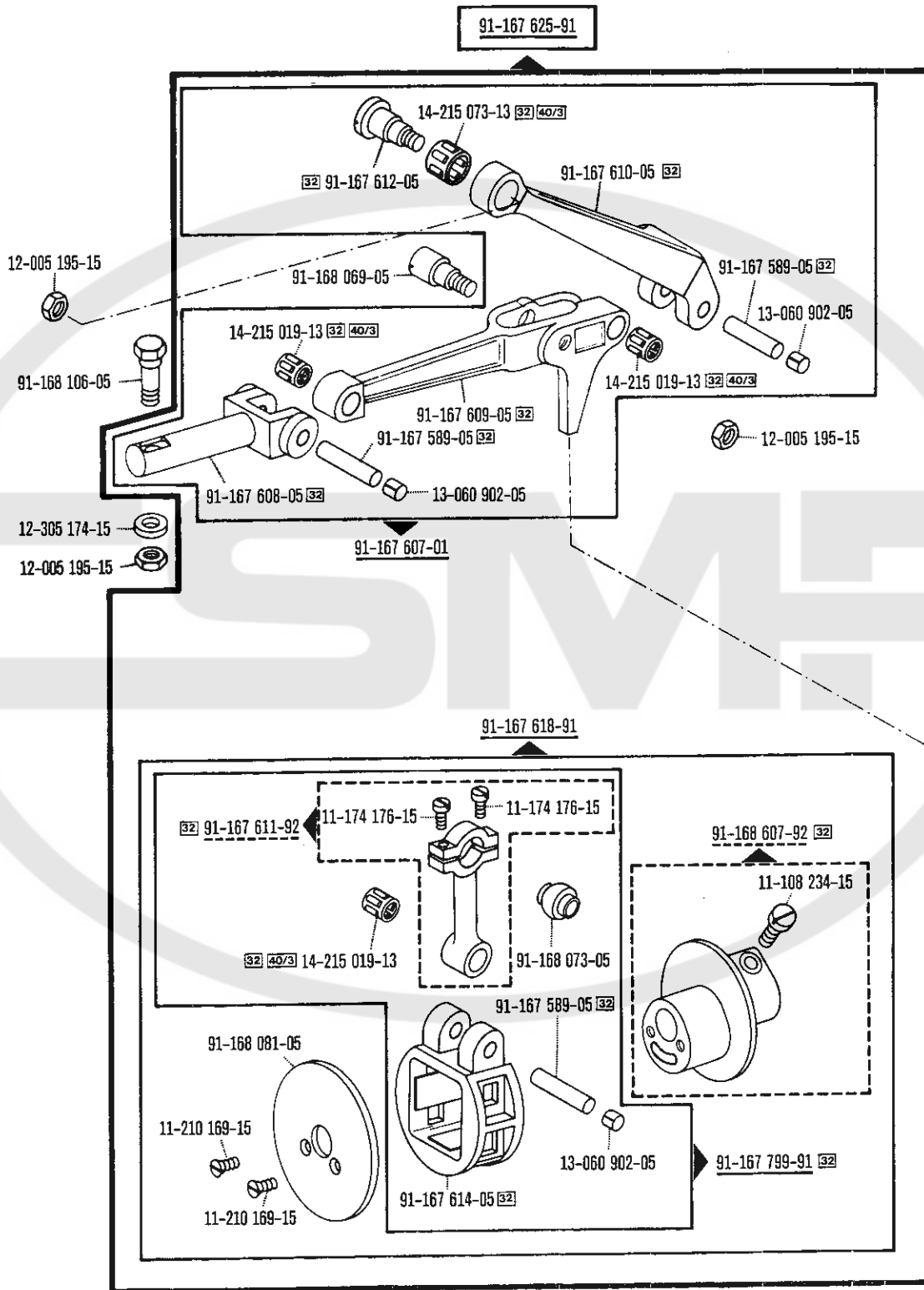

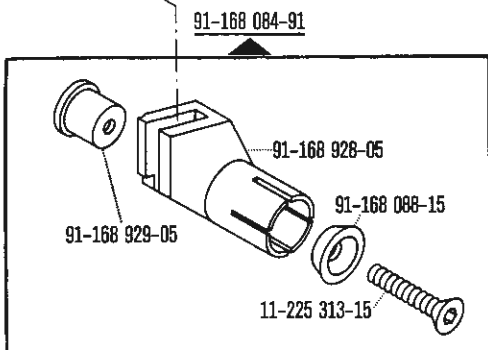
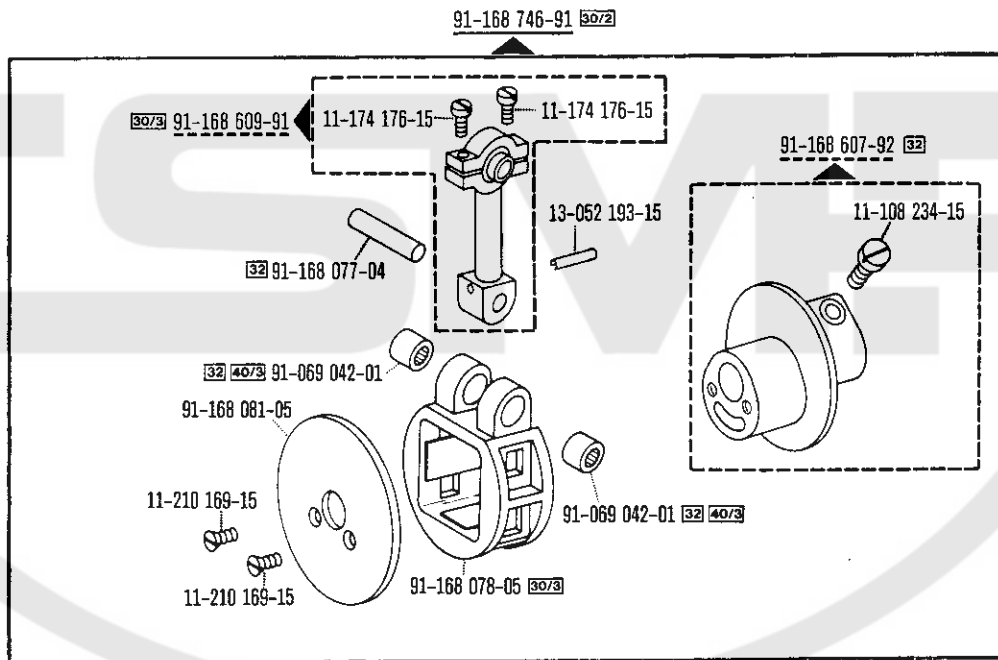
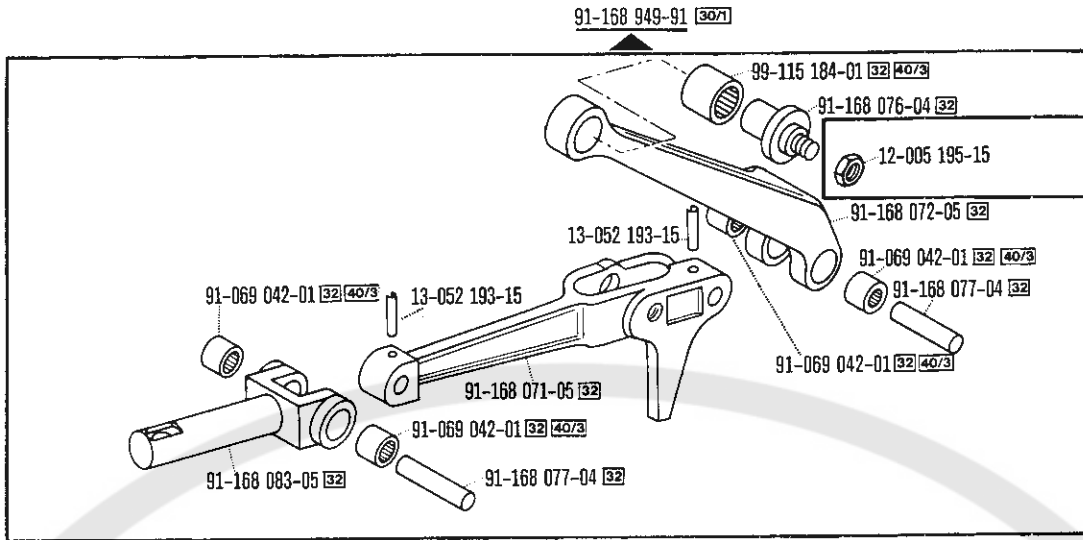

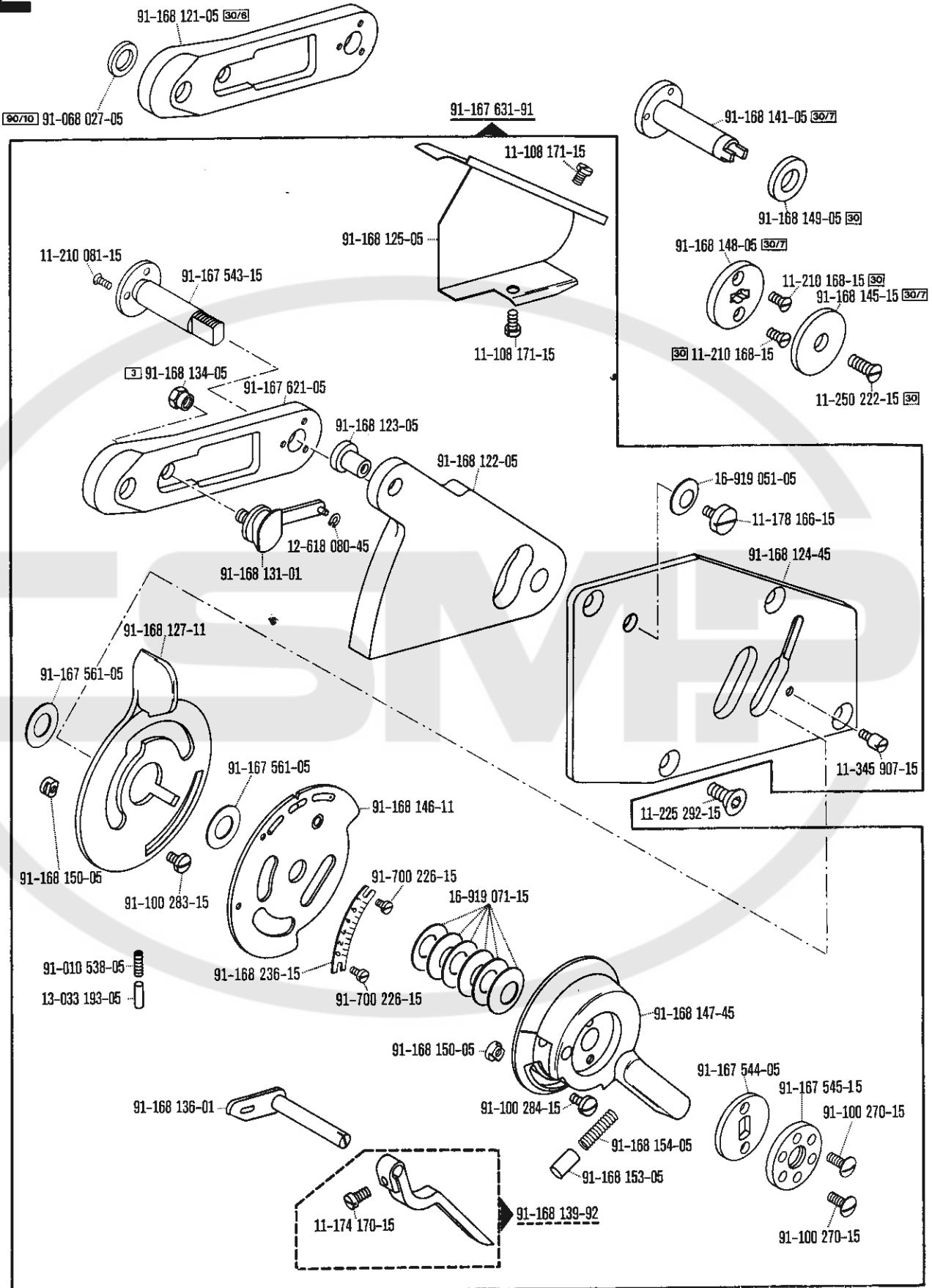

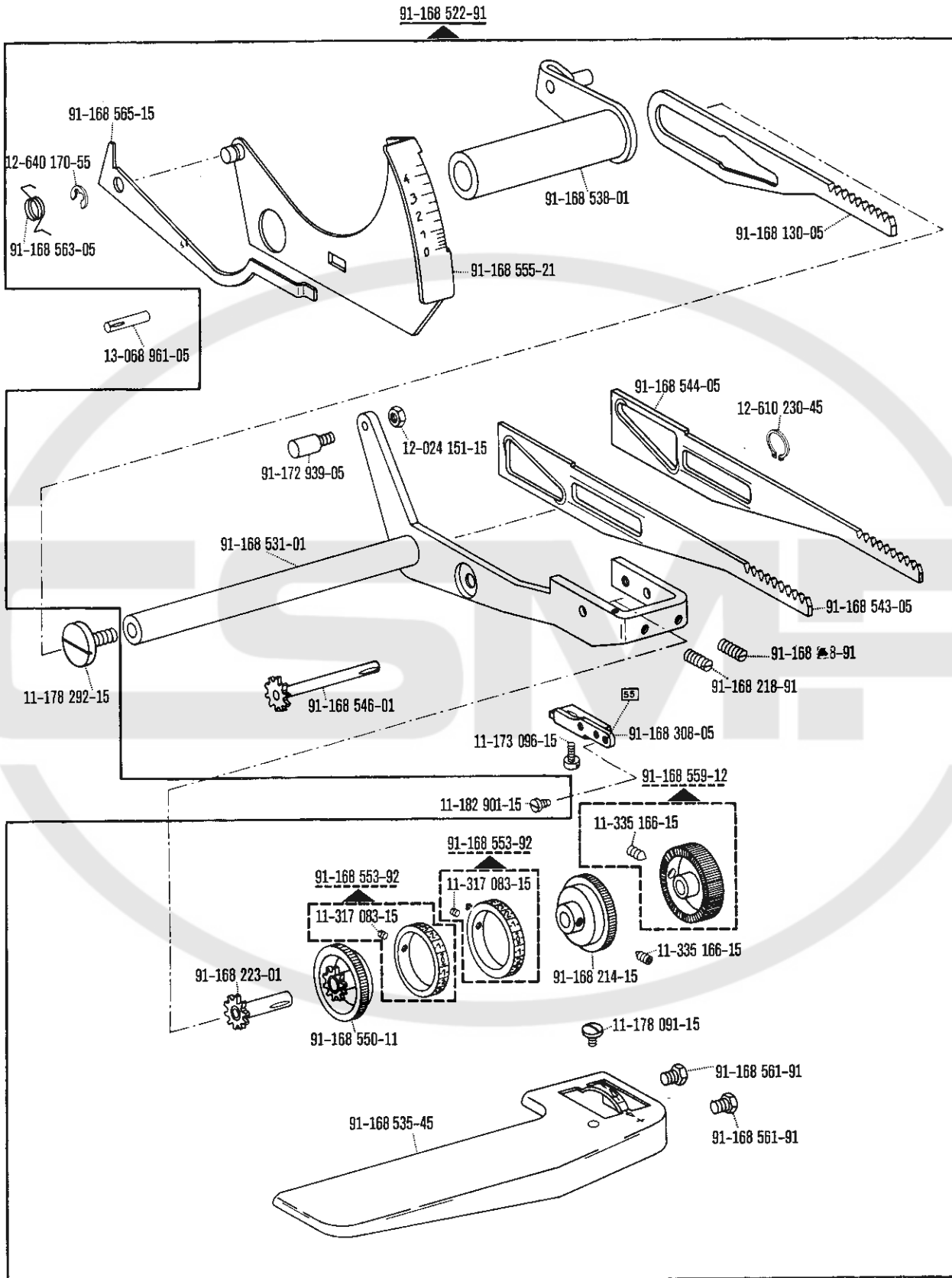

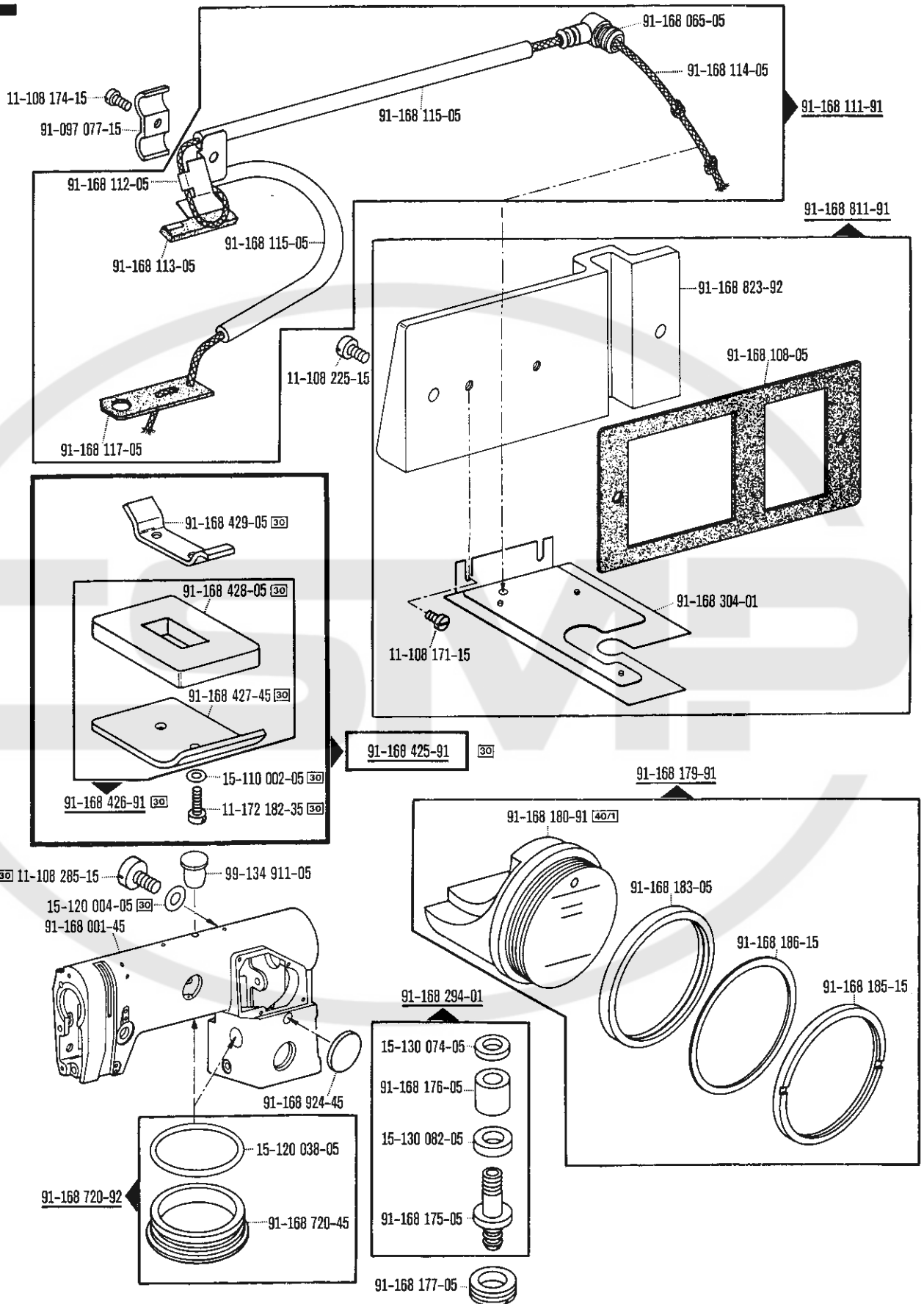

91-168 840-91

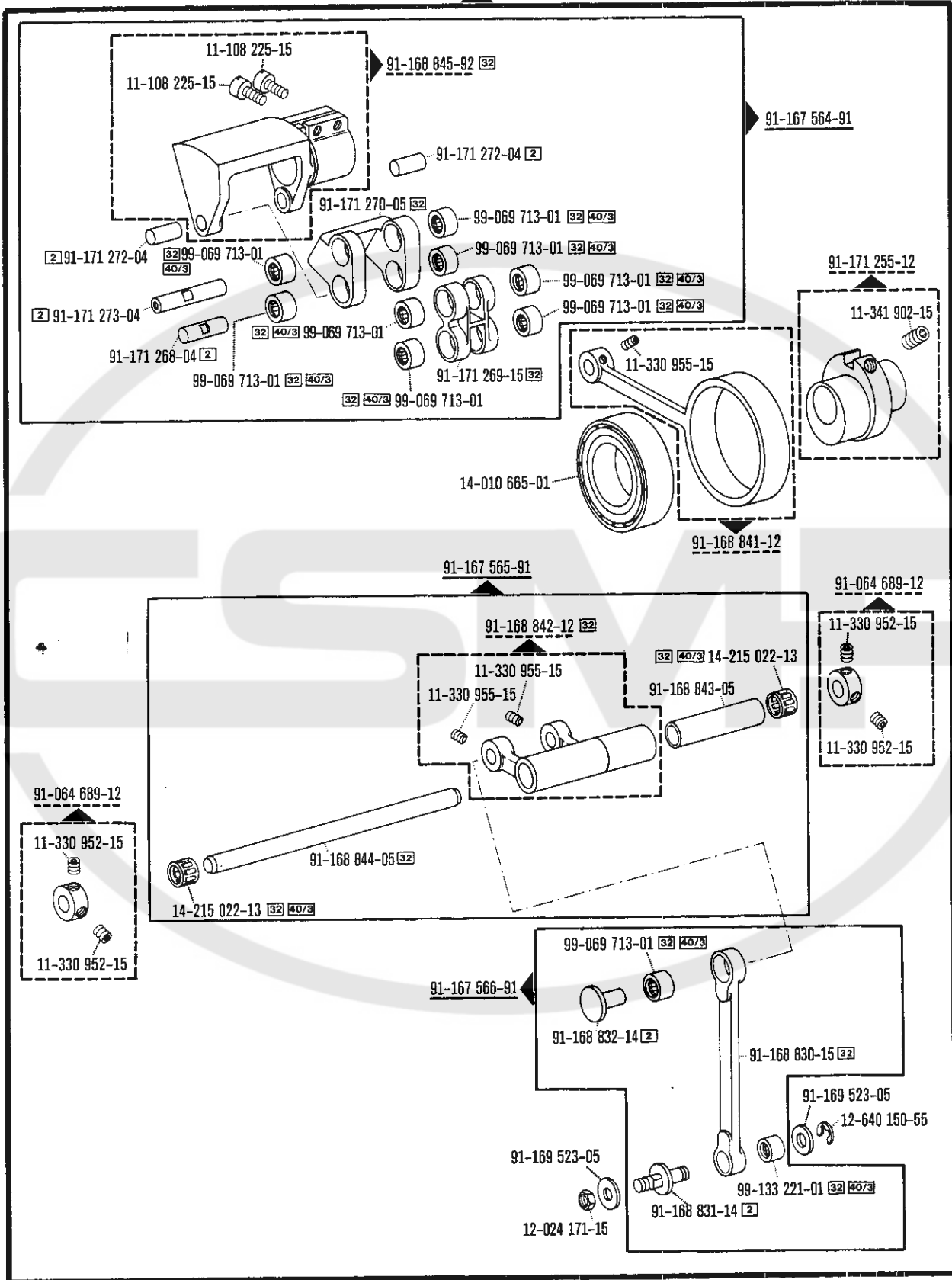

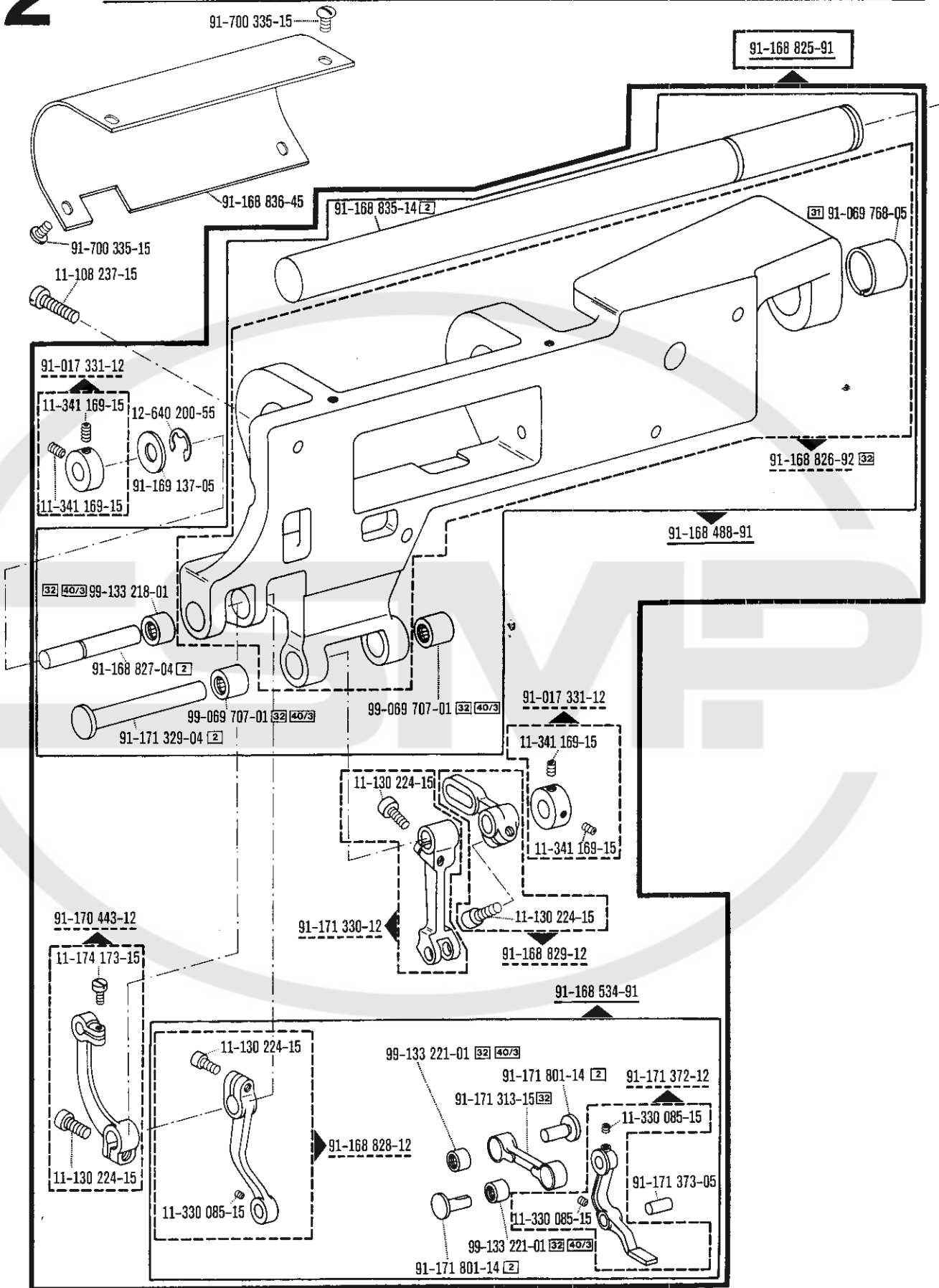

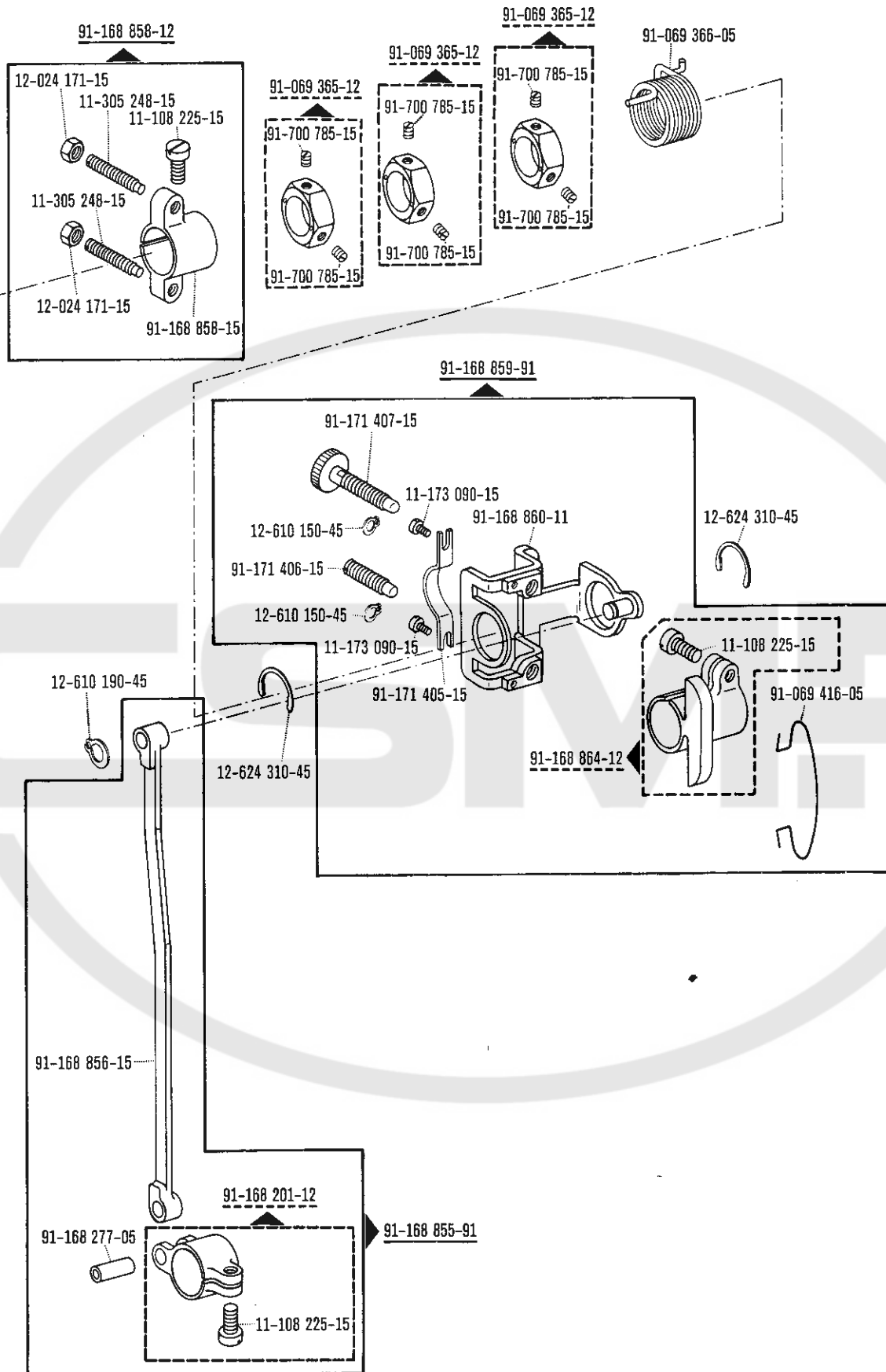

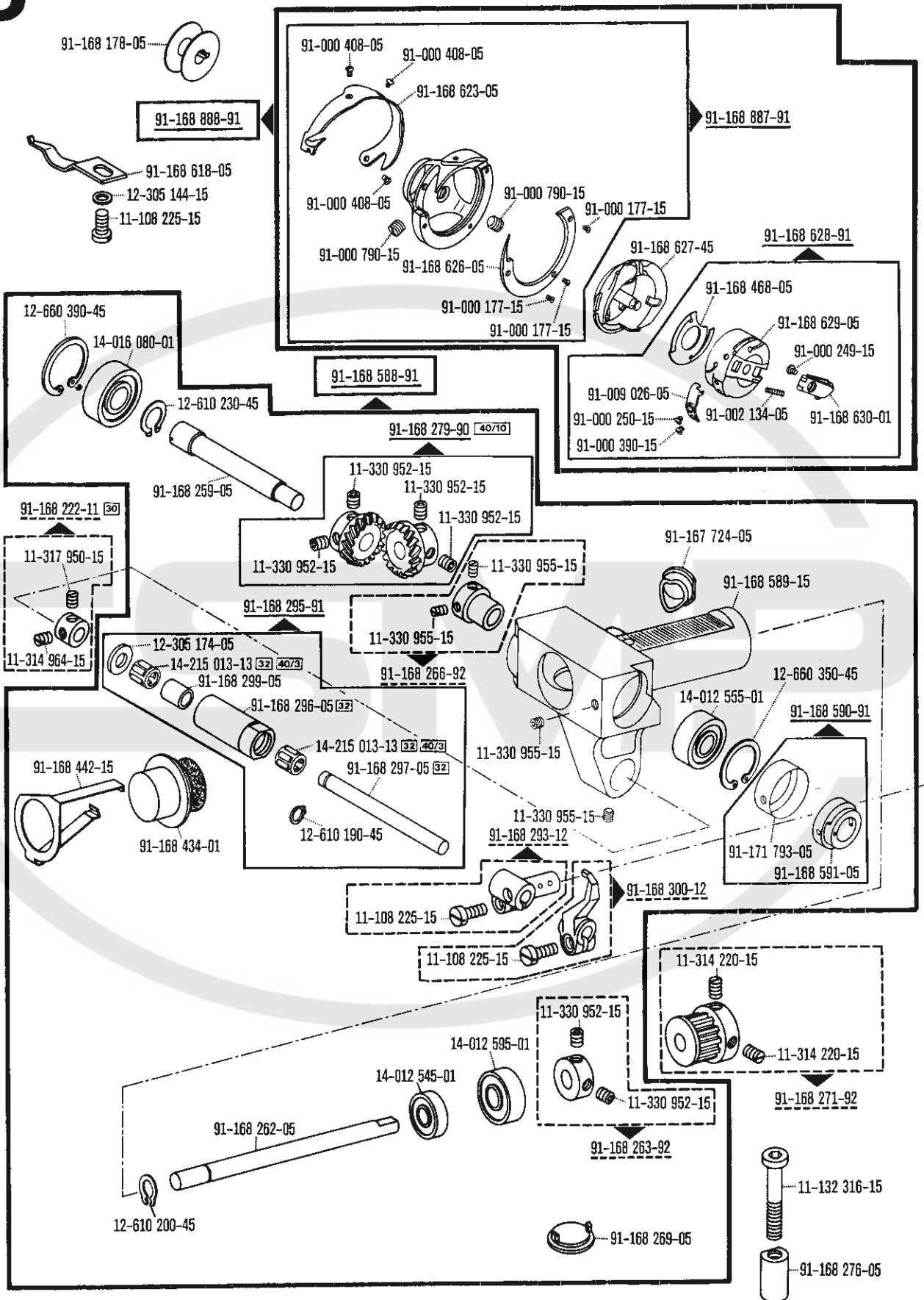

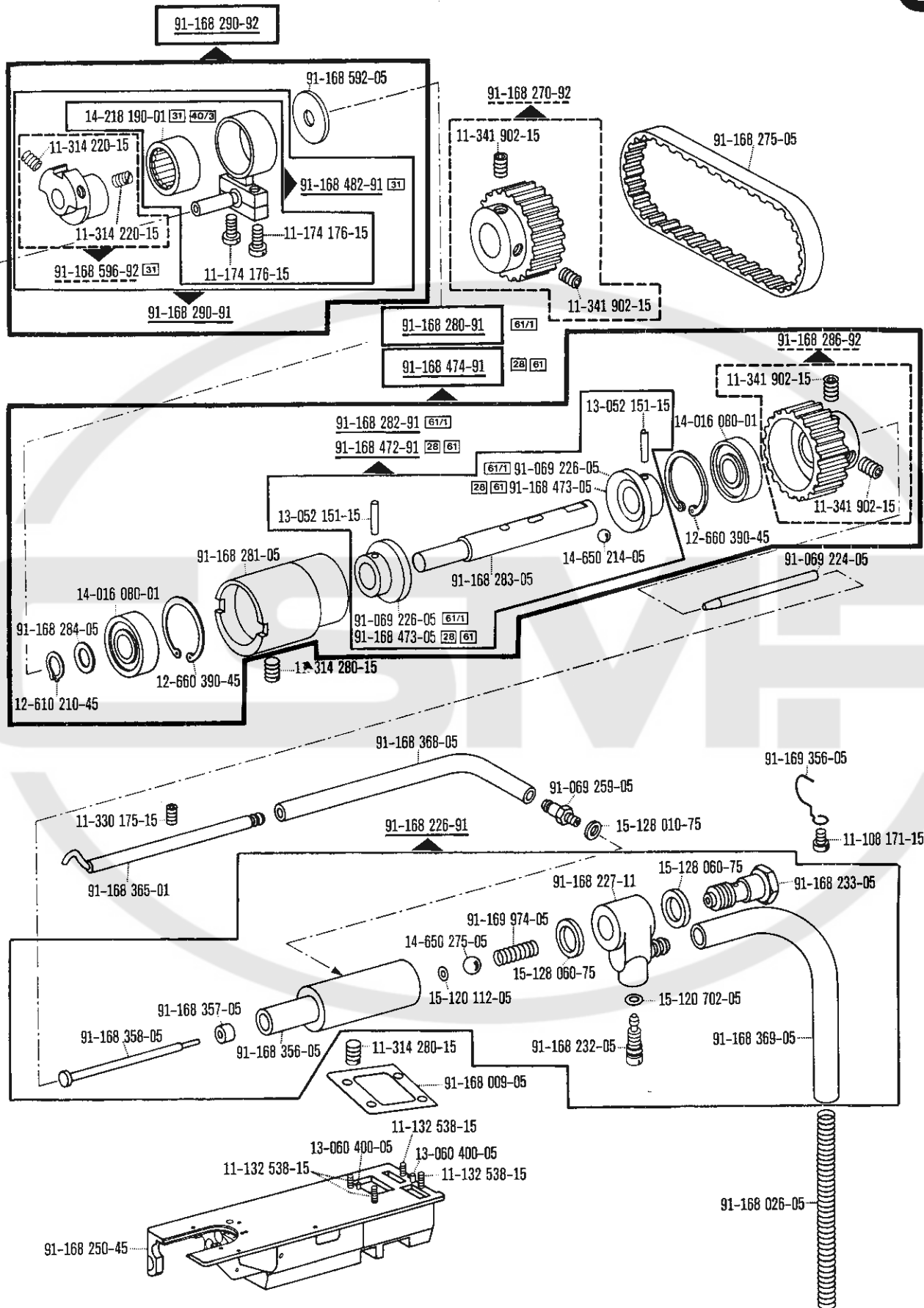

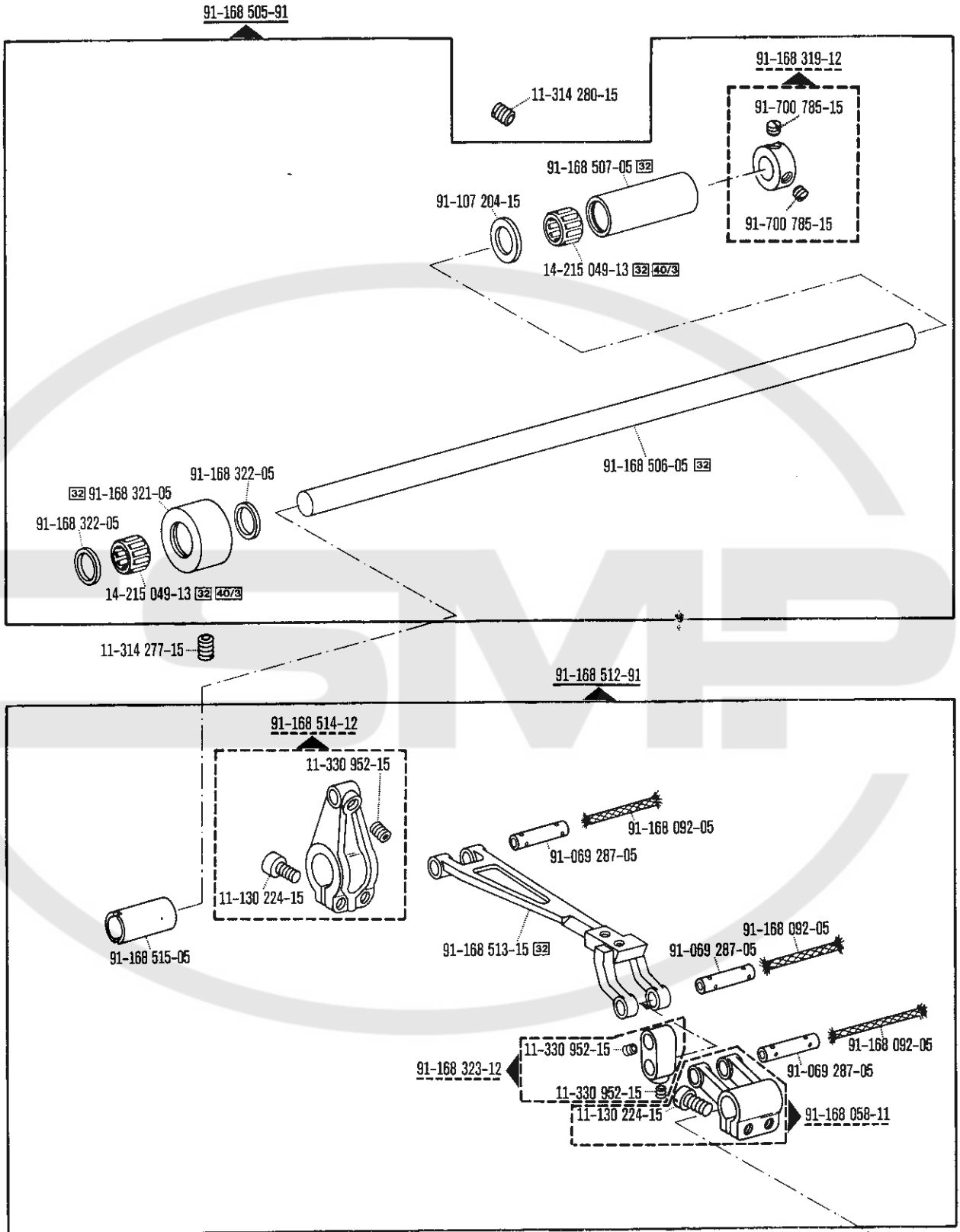

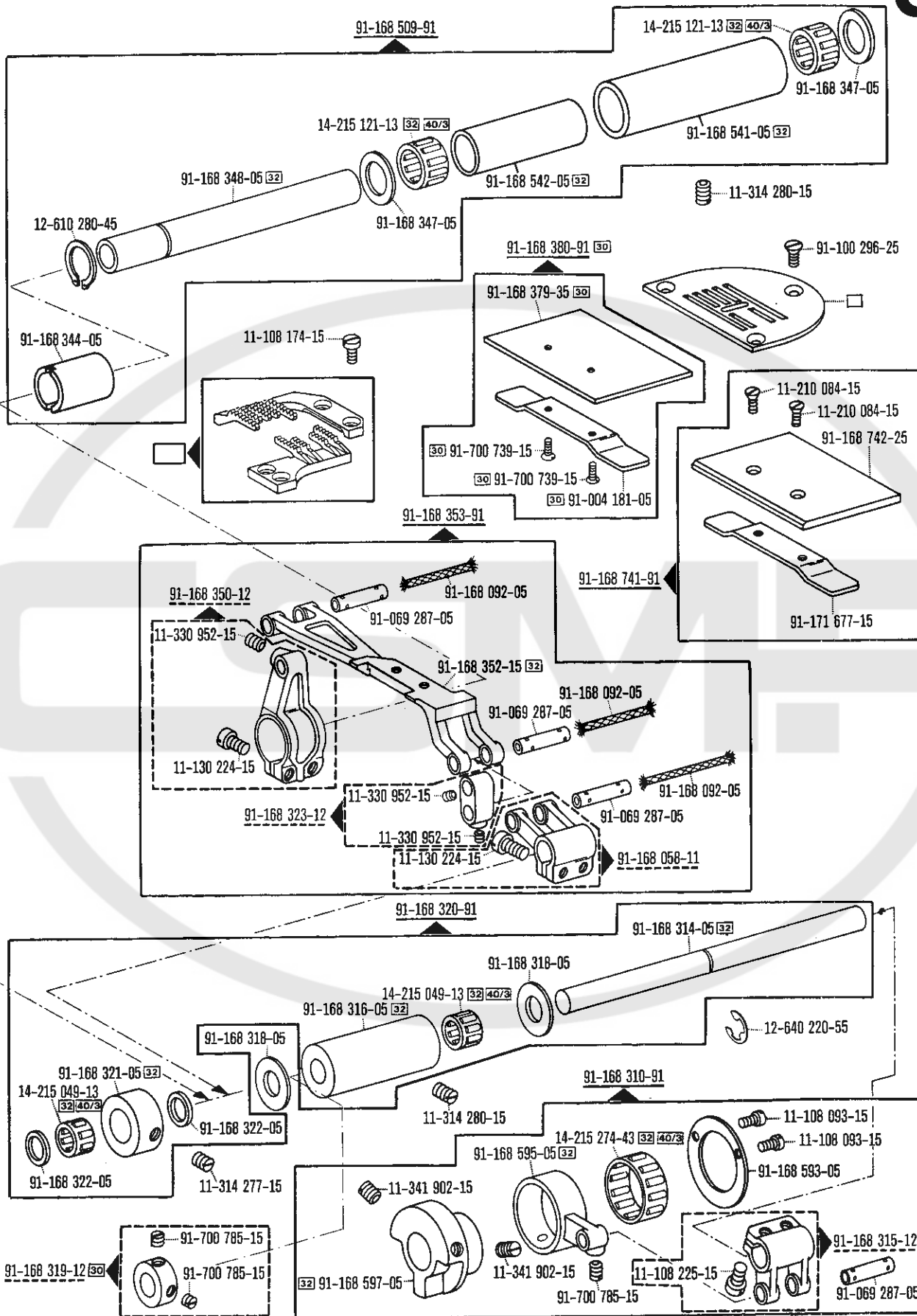

00-000 000-00 00-000 000-00 00-000 000-00 [30] [32] [40/3] siehe Erläuterungen Seite 5
 see explanations on page 7
 voir légende page 9

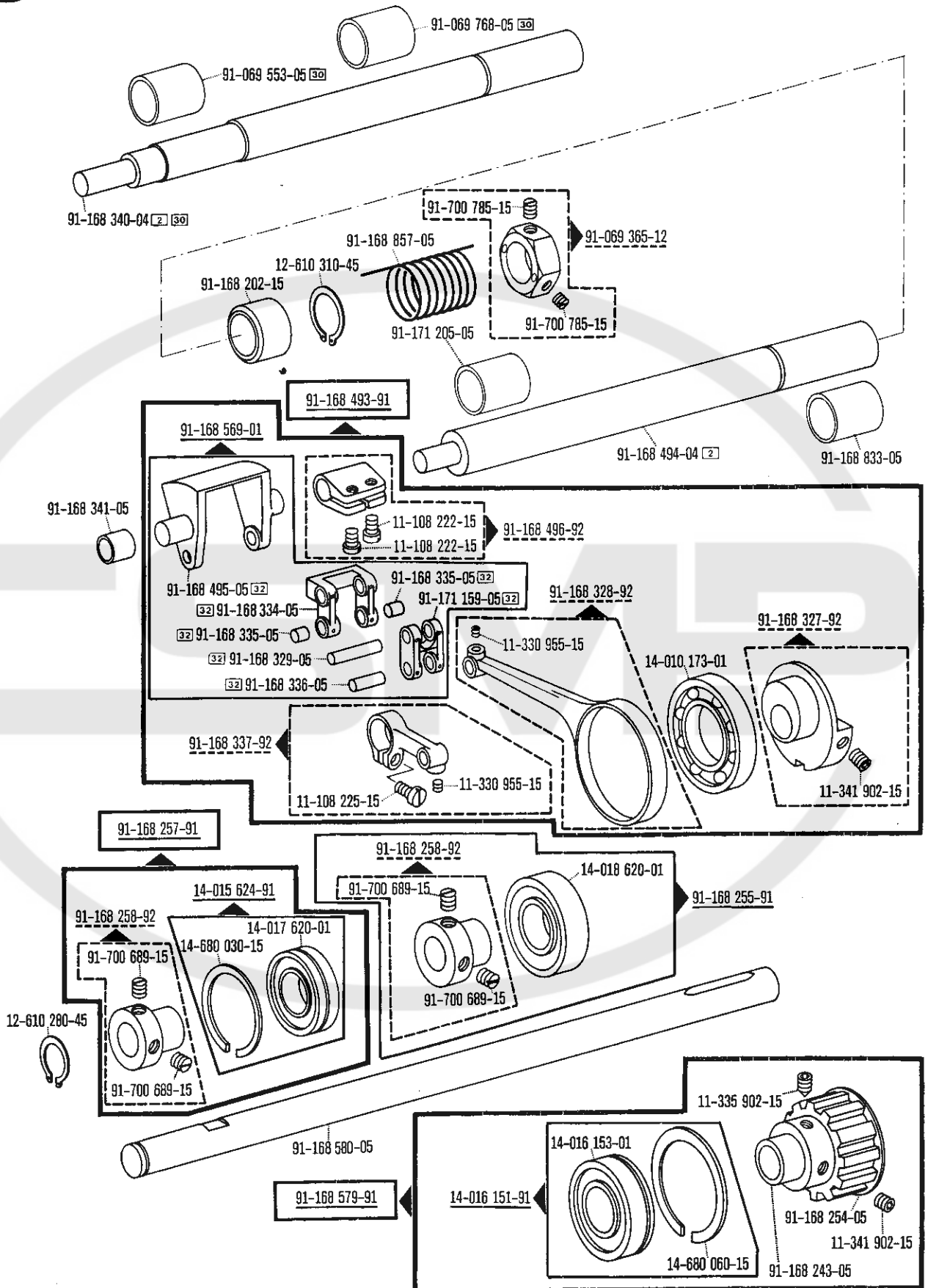

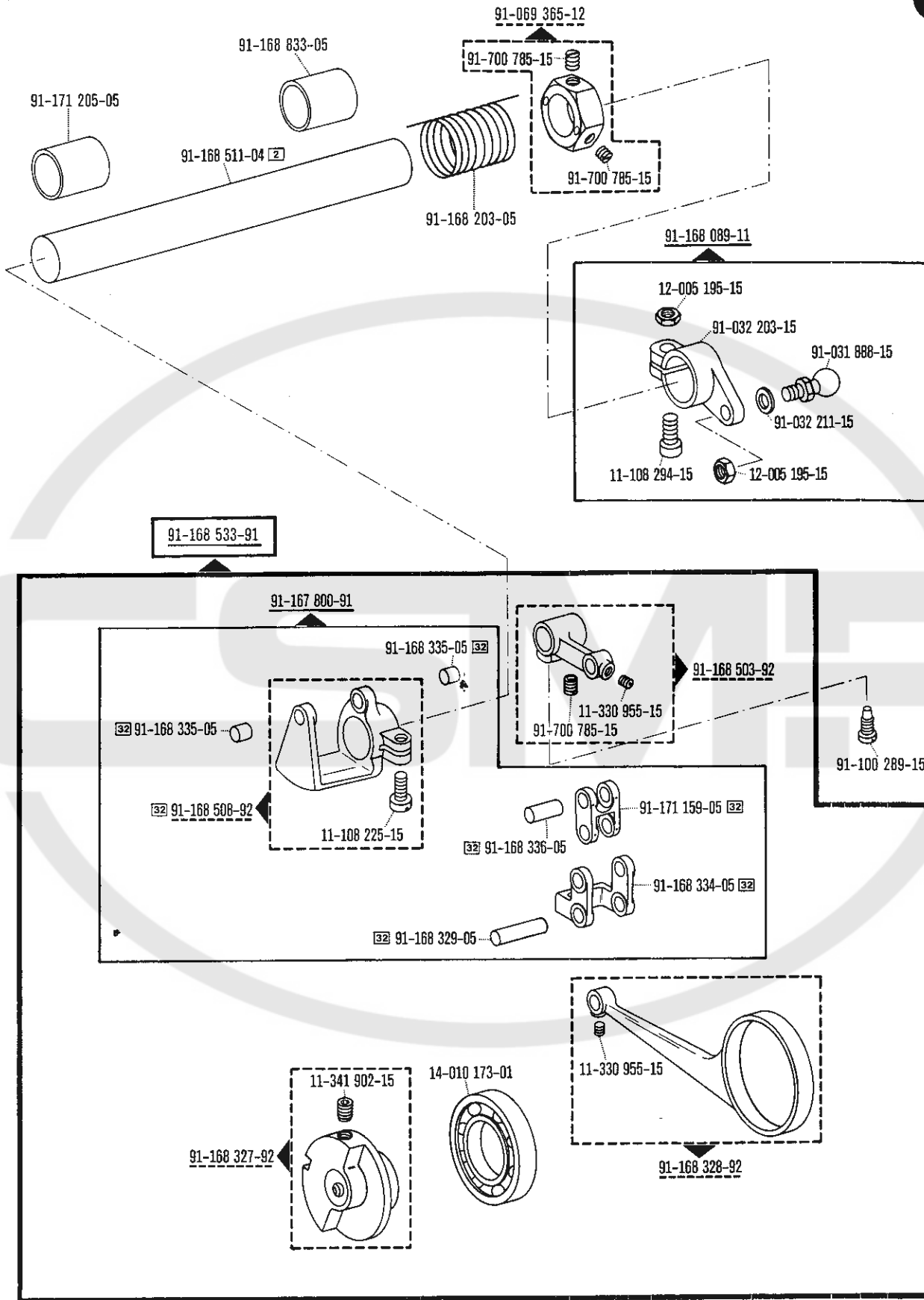

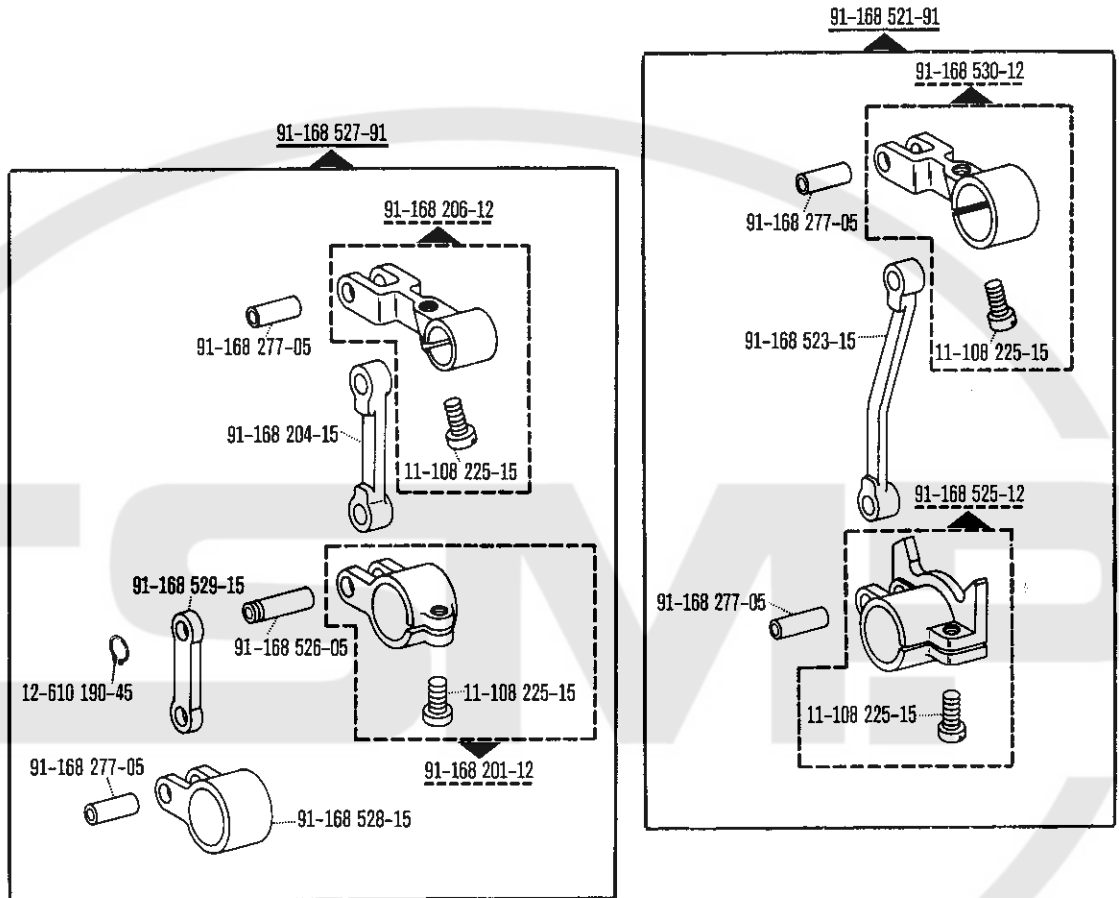

40/2 91-168 384-05

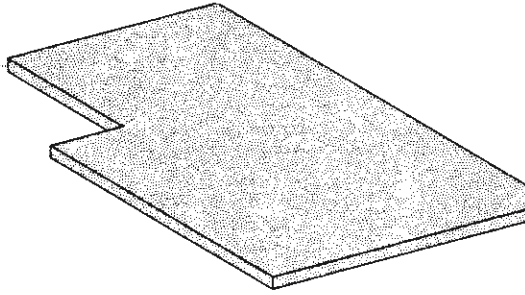

40/2 91-168 383-05

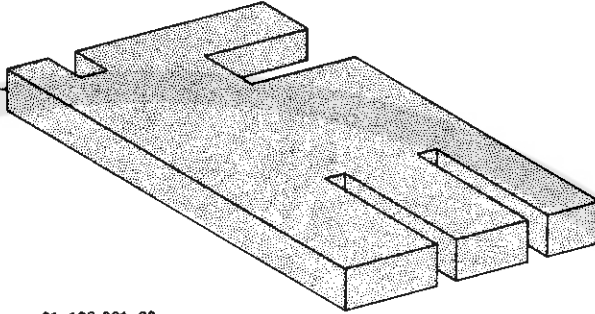

91-168 381-92

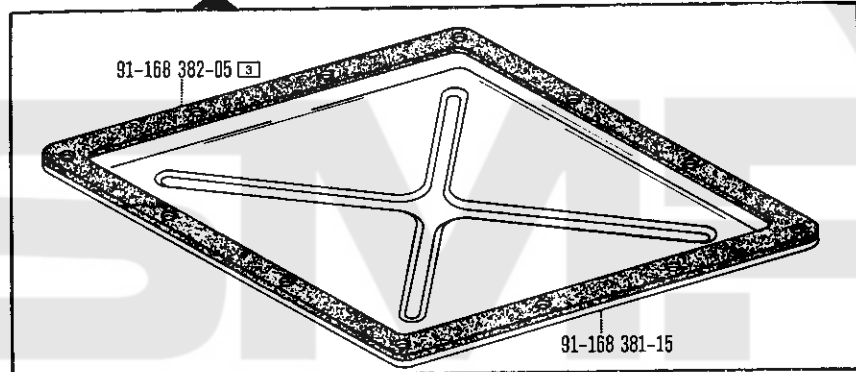

11-108 180-15

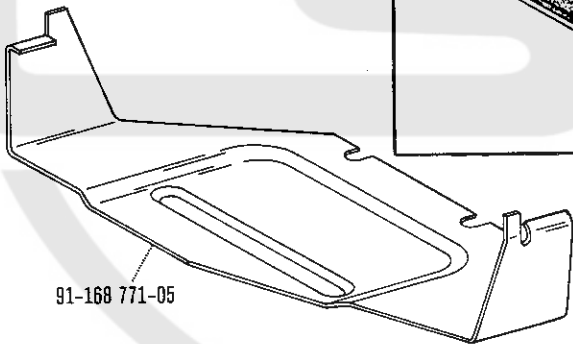

91-168 771-05



91-168 377-05



91-168 256-05

91-168 370-91

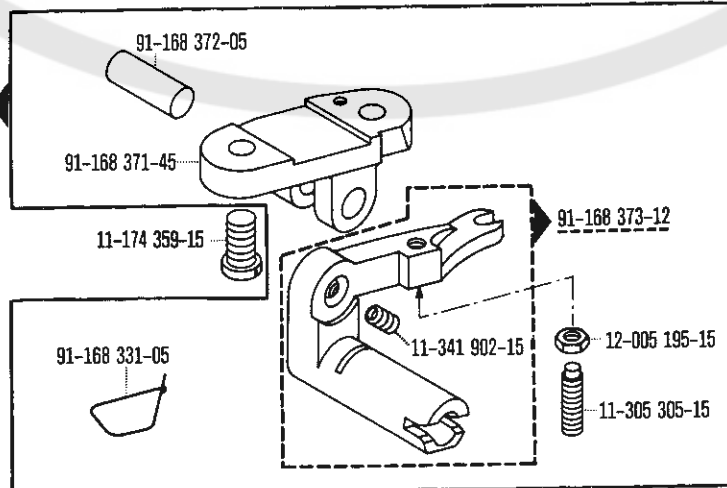

91-168 372-05

91-168 371-45

11-174 359-15

91-168 331-05

91-168 373-12

11-341 902-15

12-005 195-15

11-305 305-15

12-305 114-15

12-024 151-15

12-024 151-15

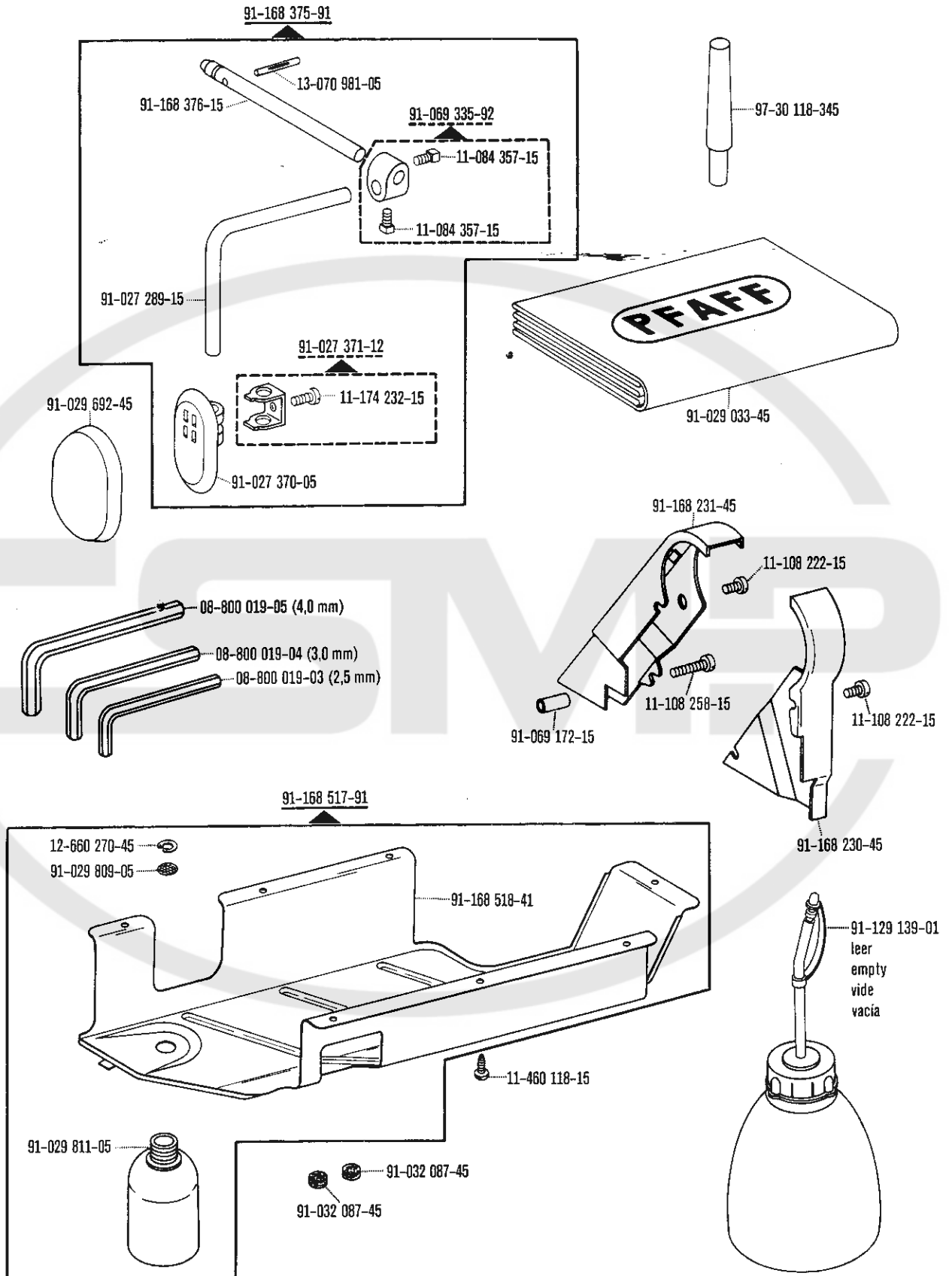

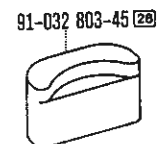
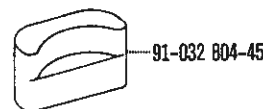
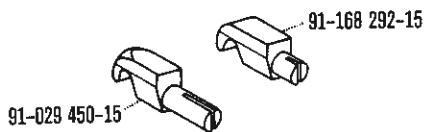
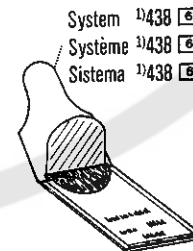
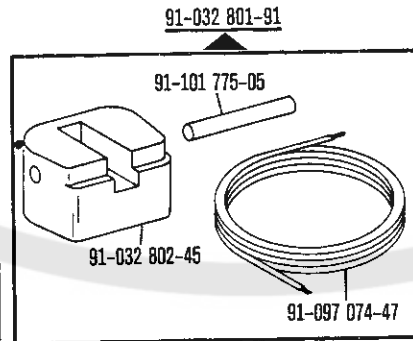
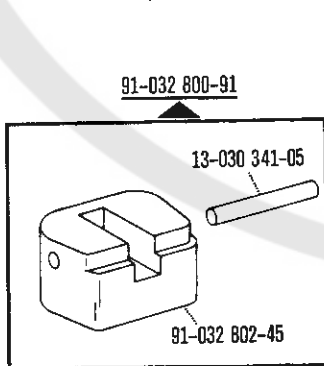
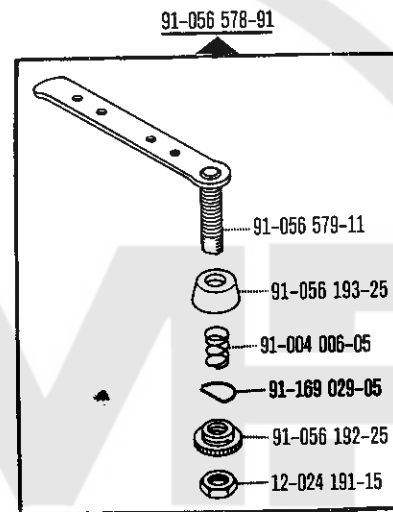
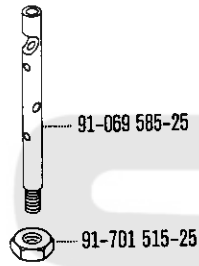
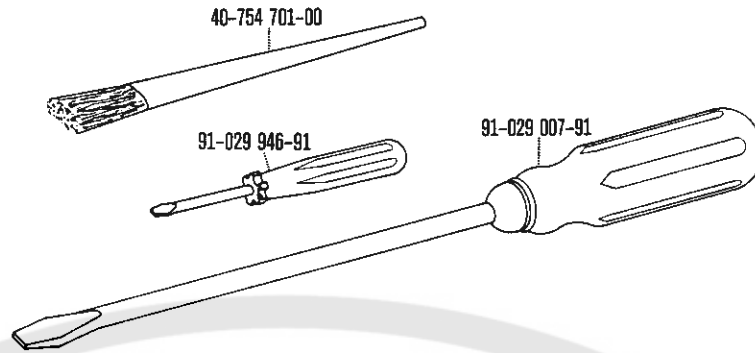

91-167 702-91

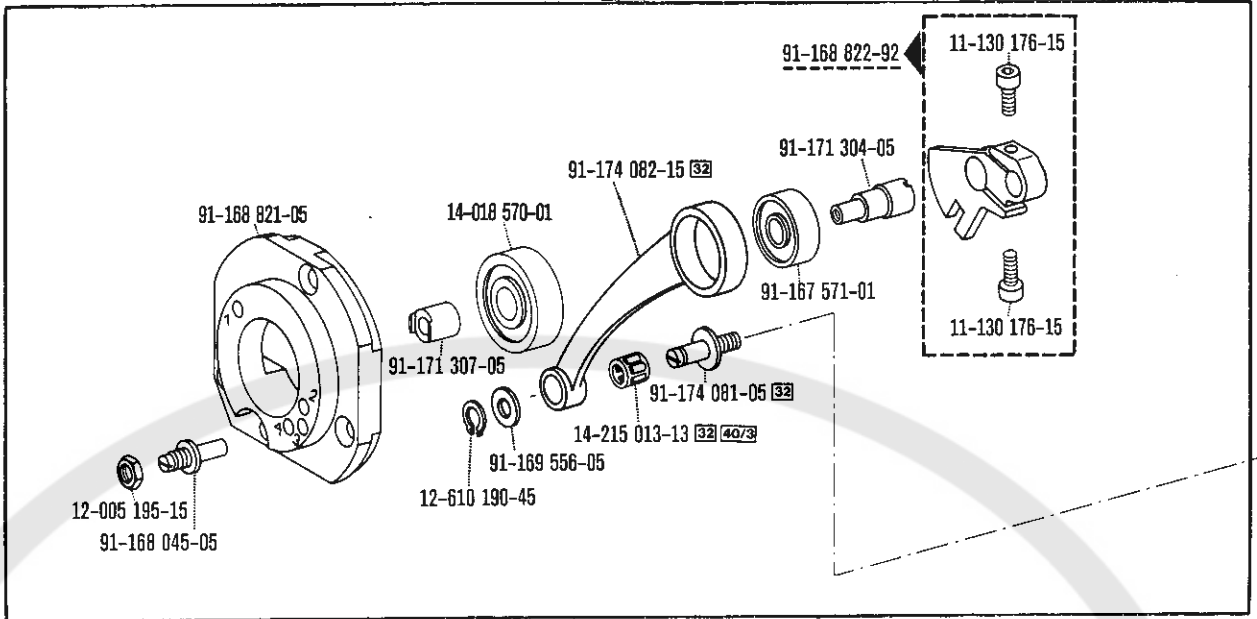

91-175 546-91

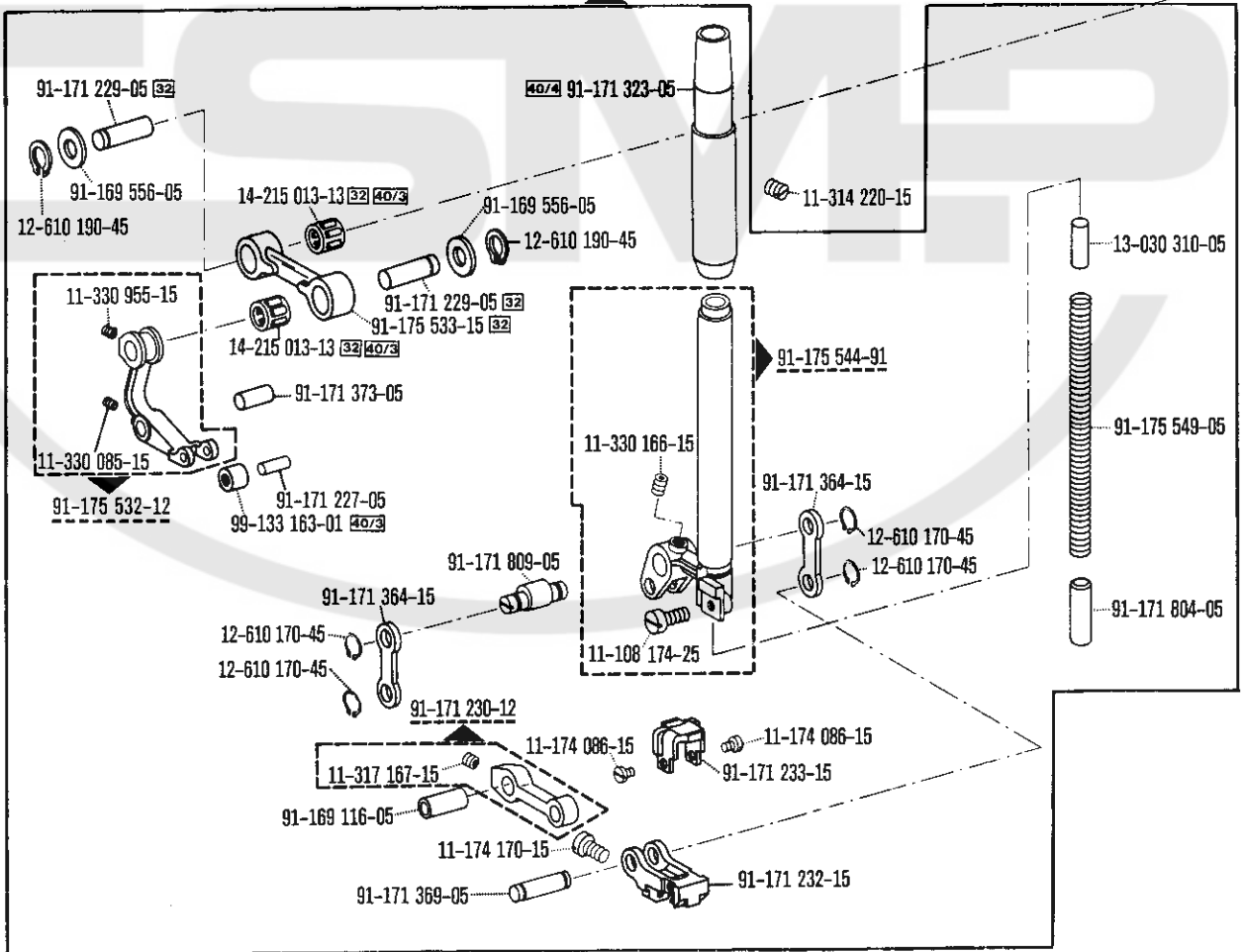

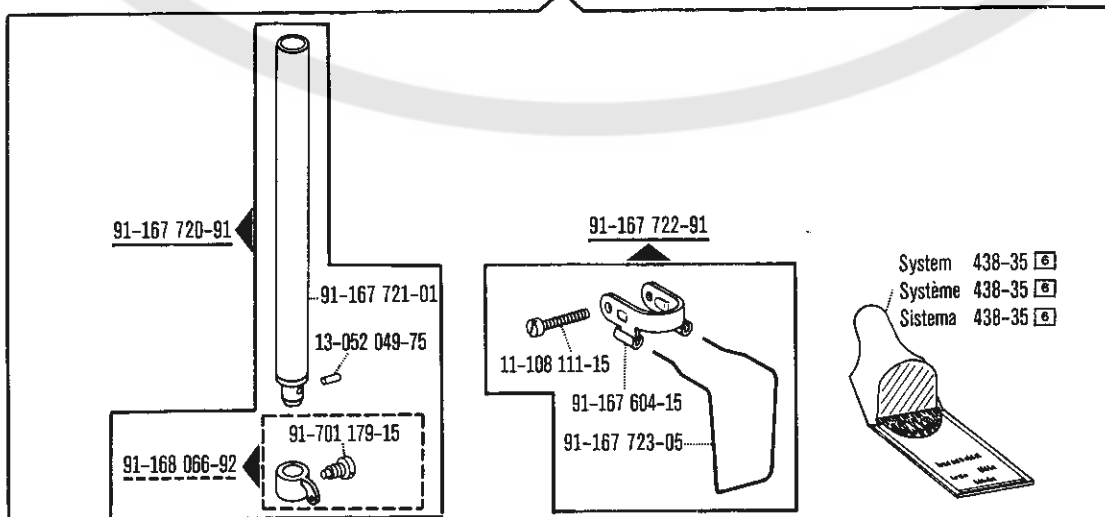
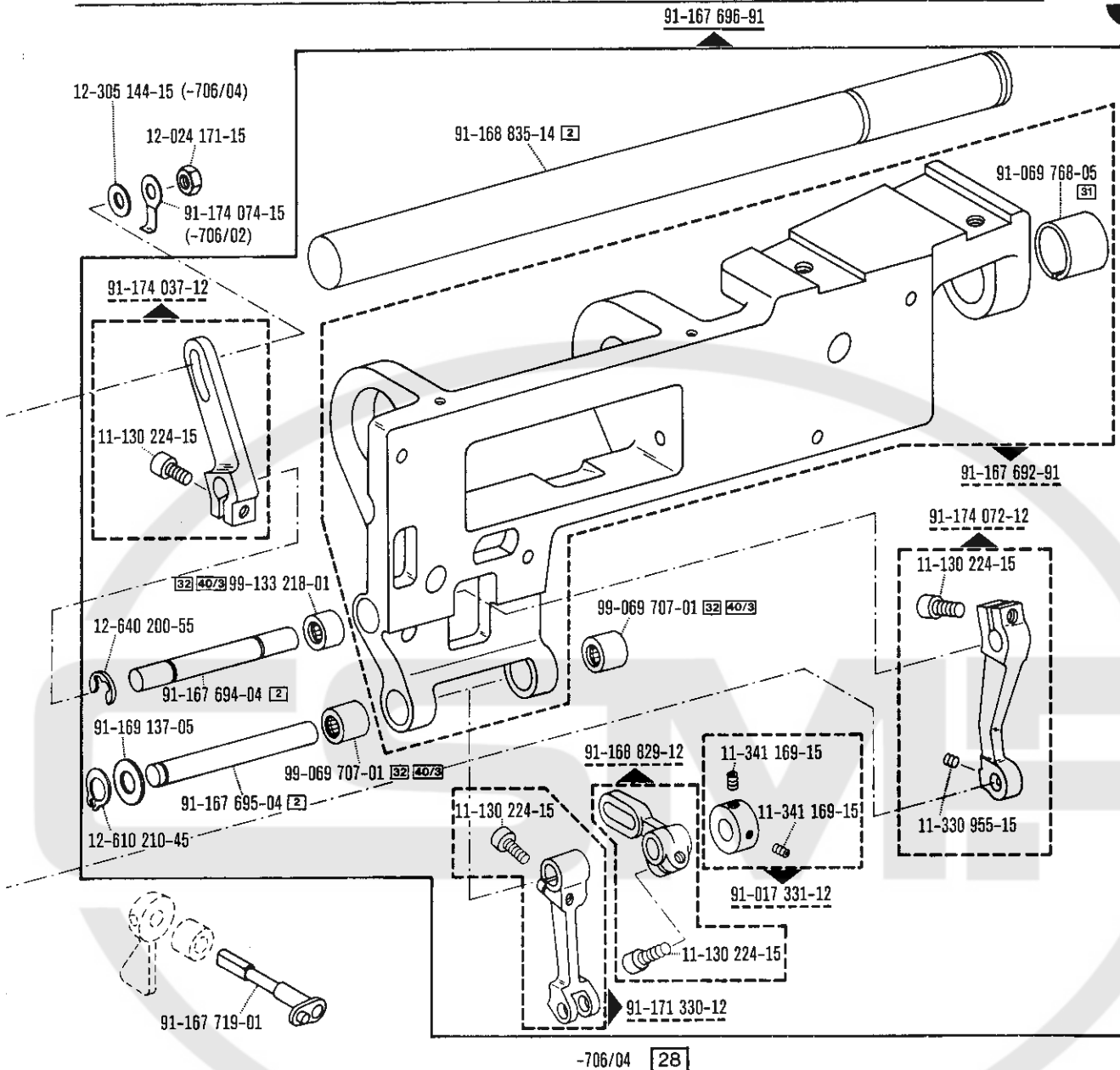

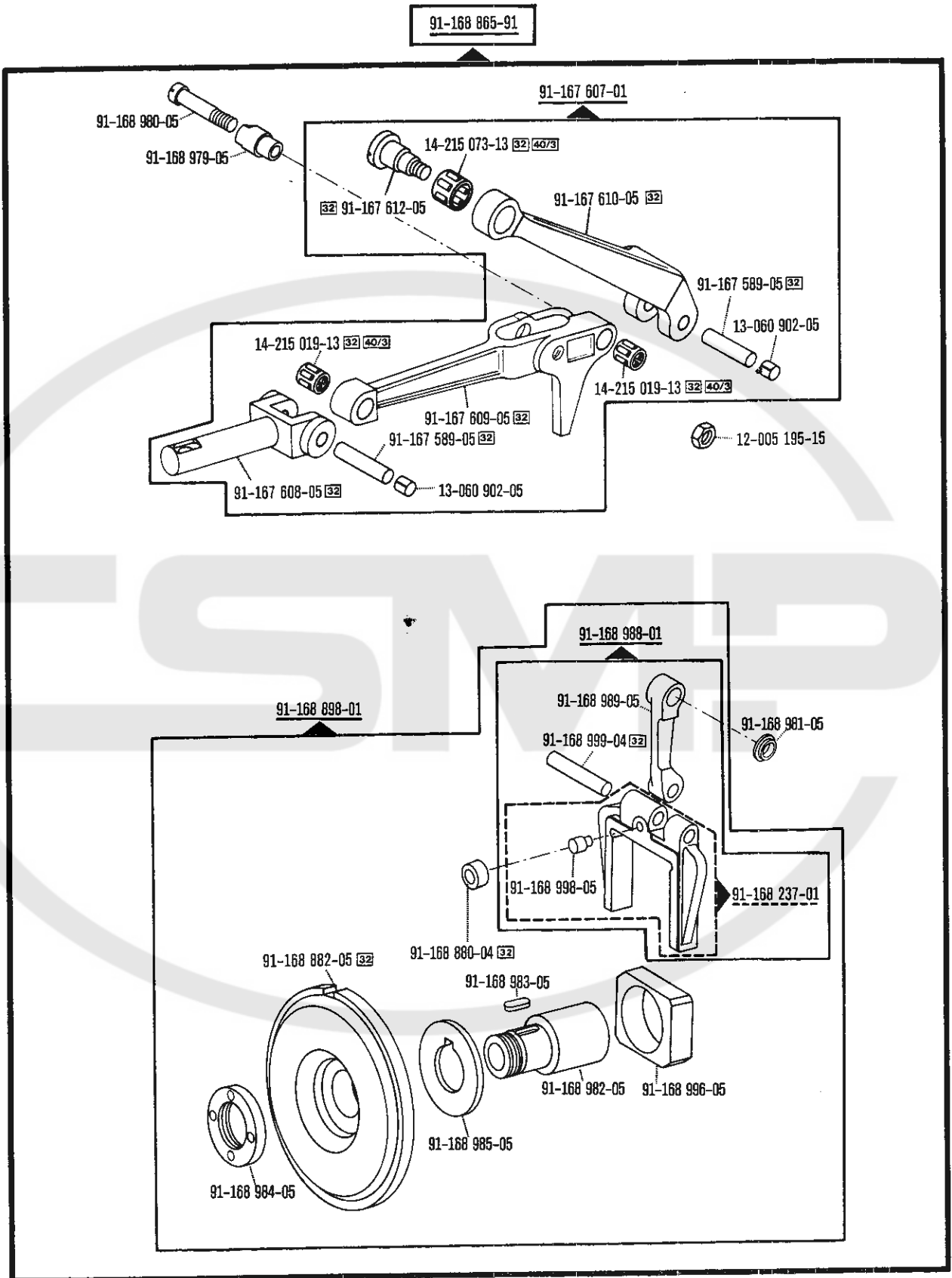

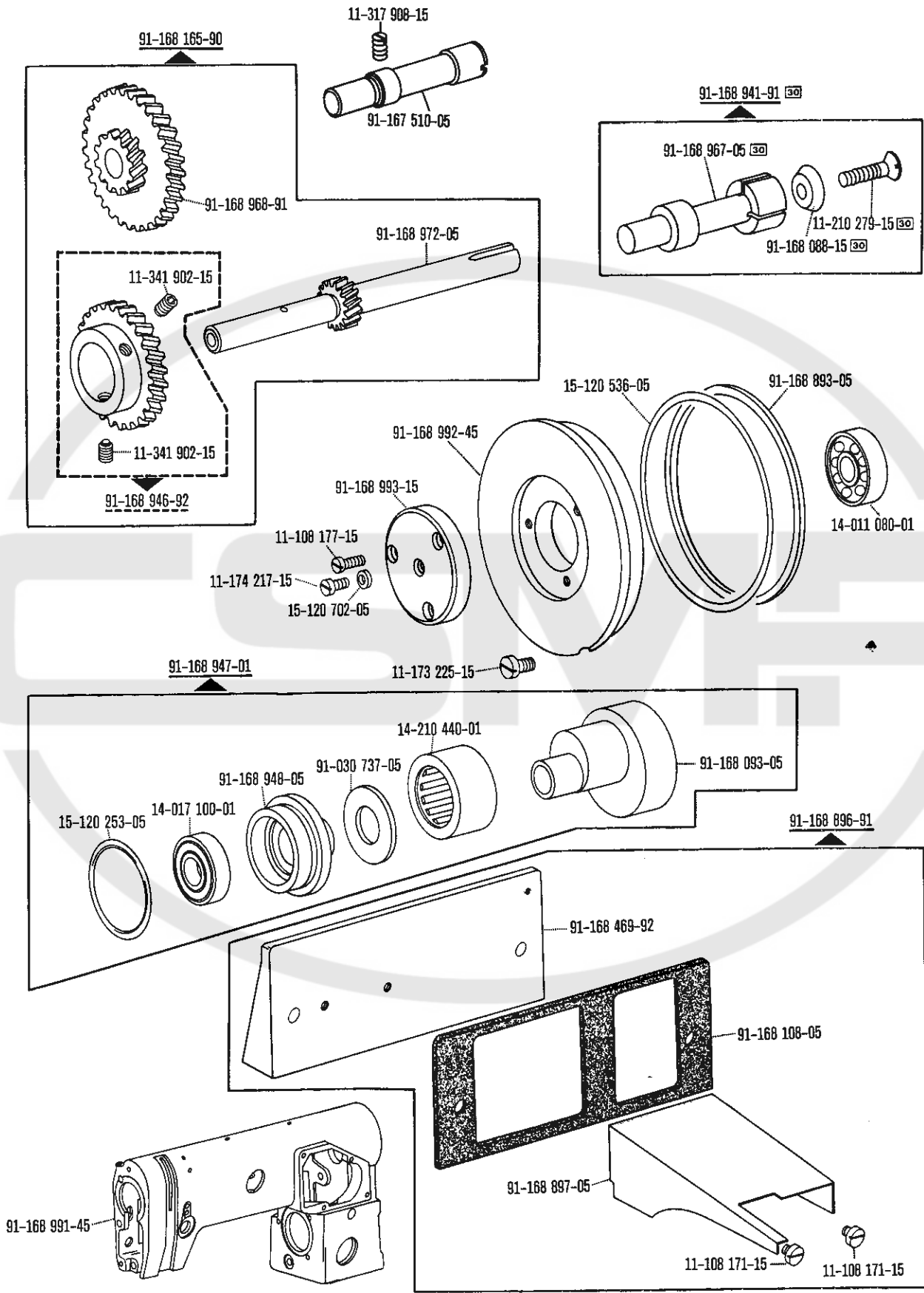

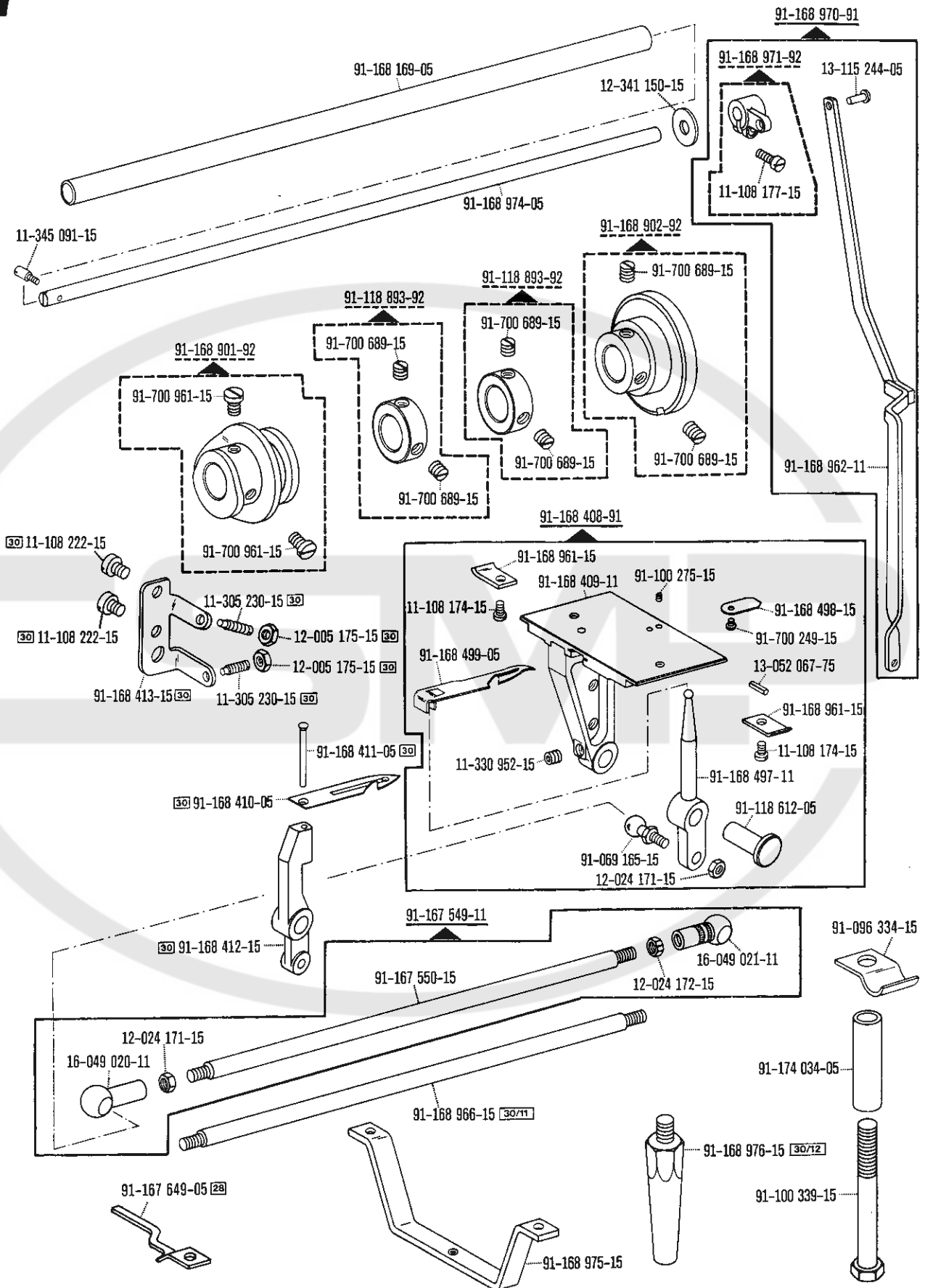

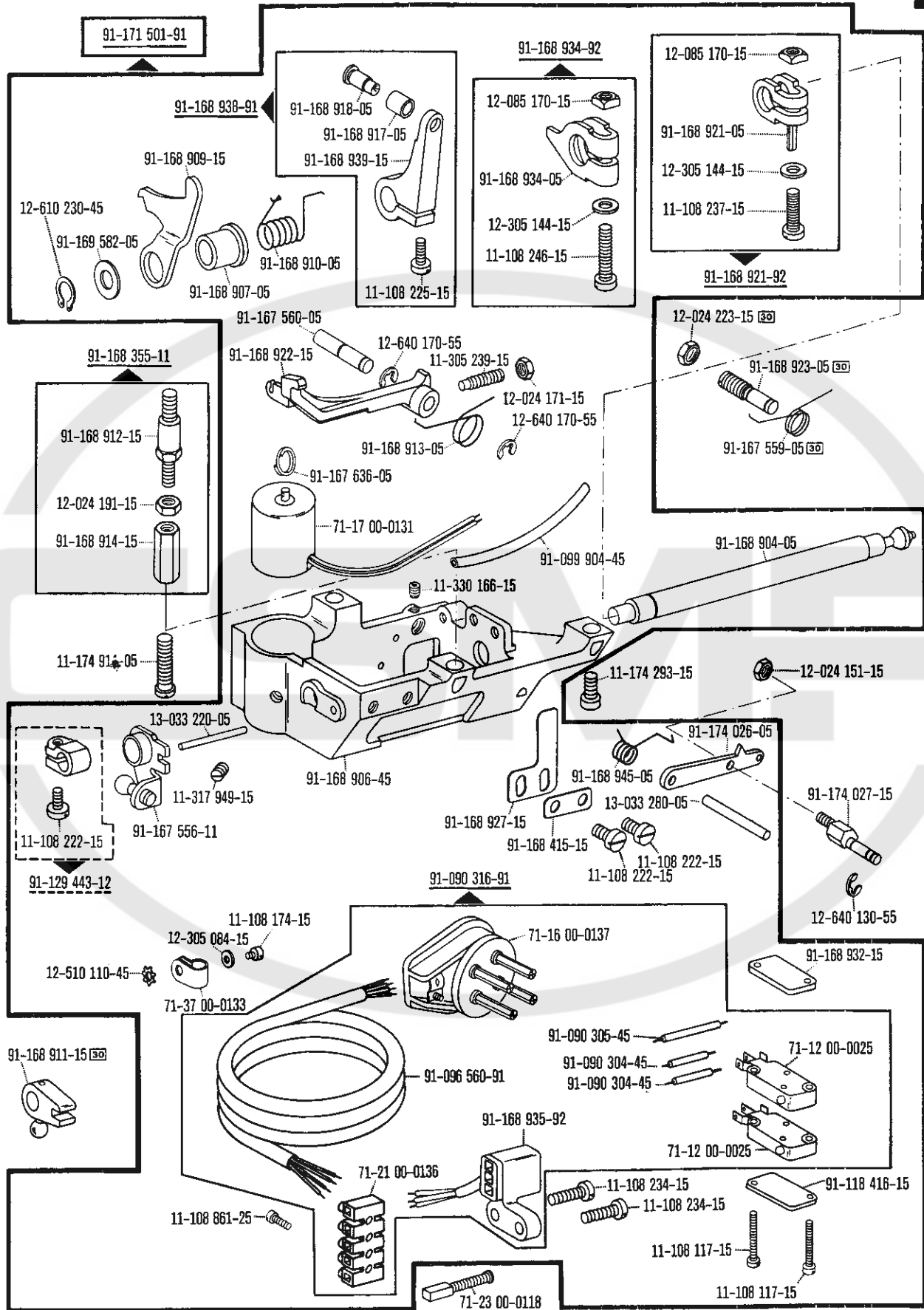

71-59 00-0259 90/71 90/8

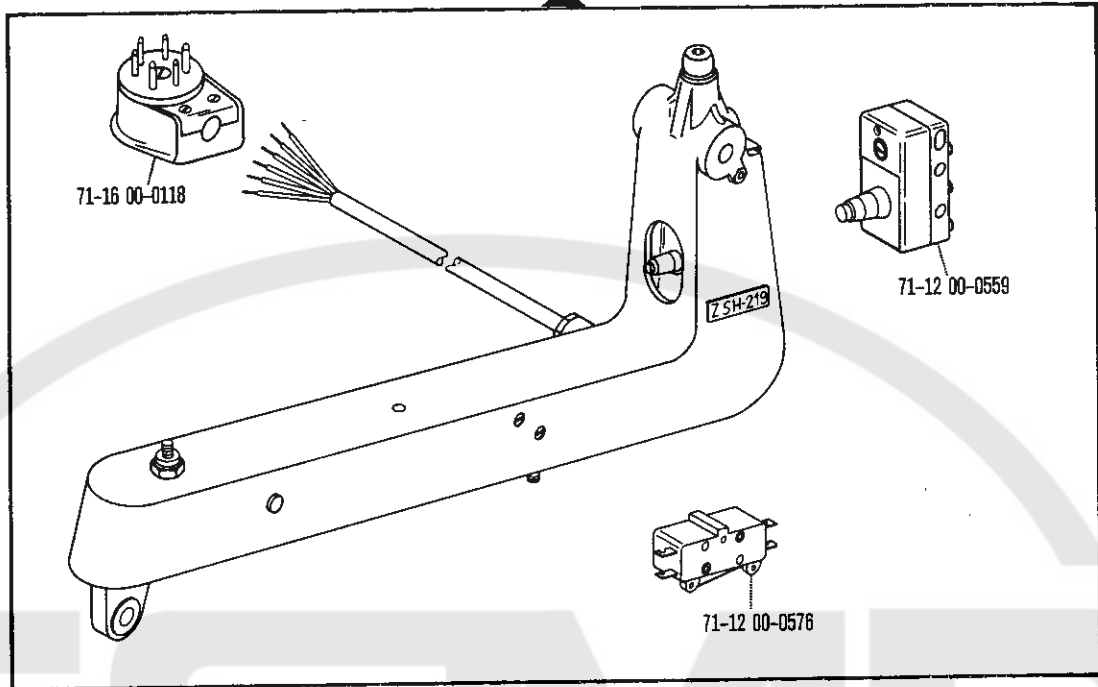

71-59 00-0268 90/71 90/8

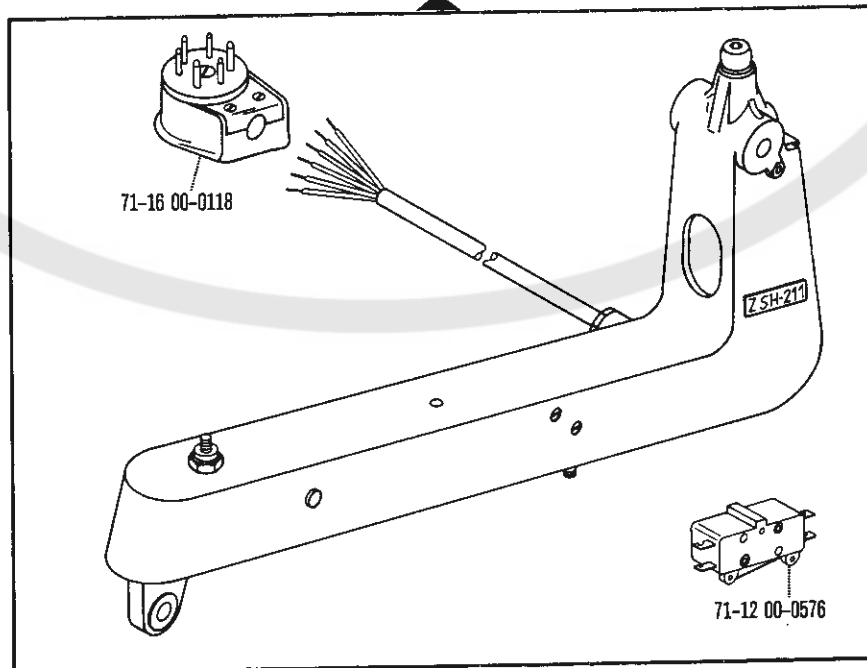

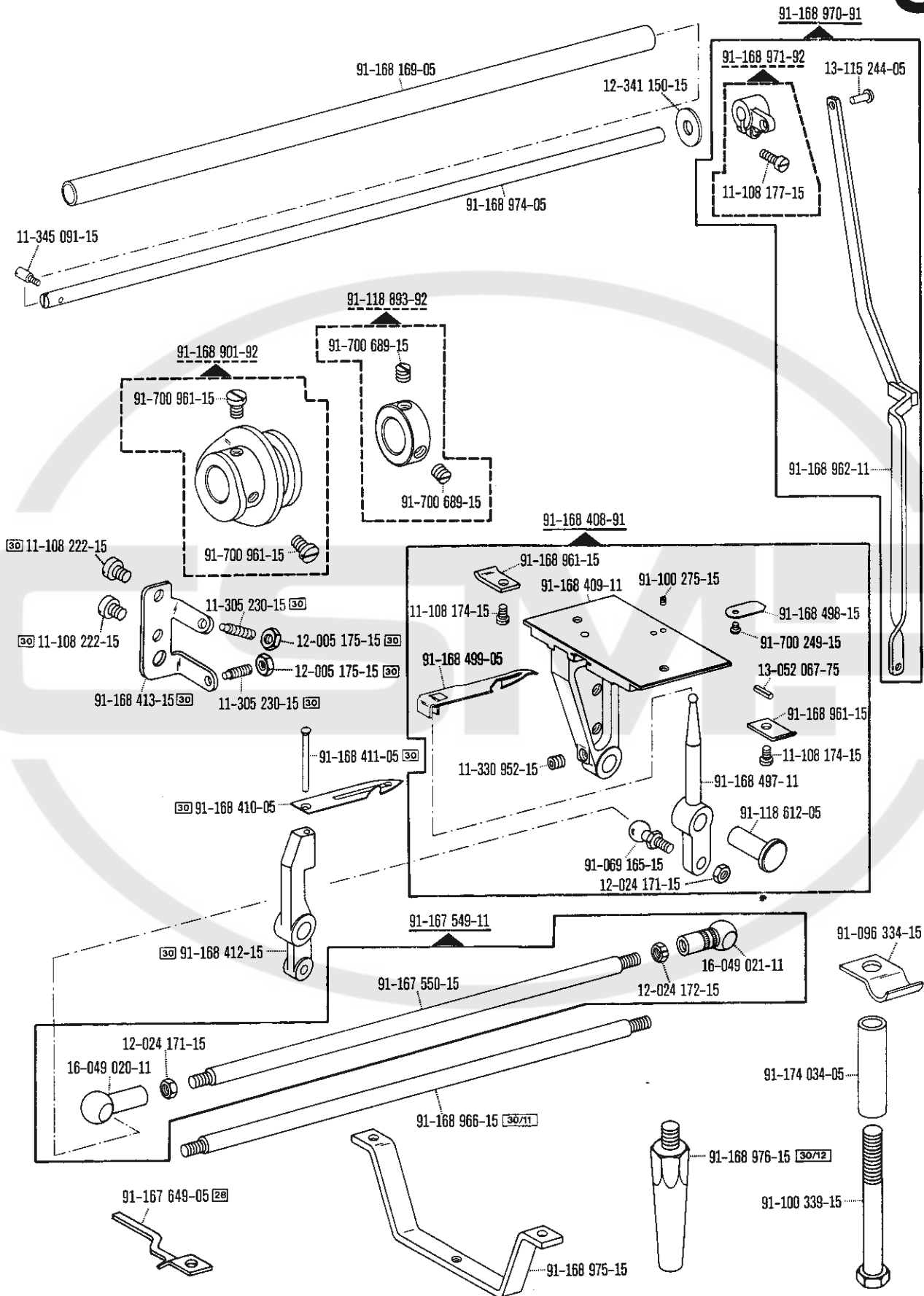

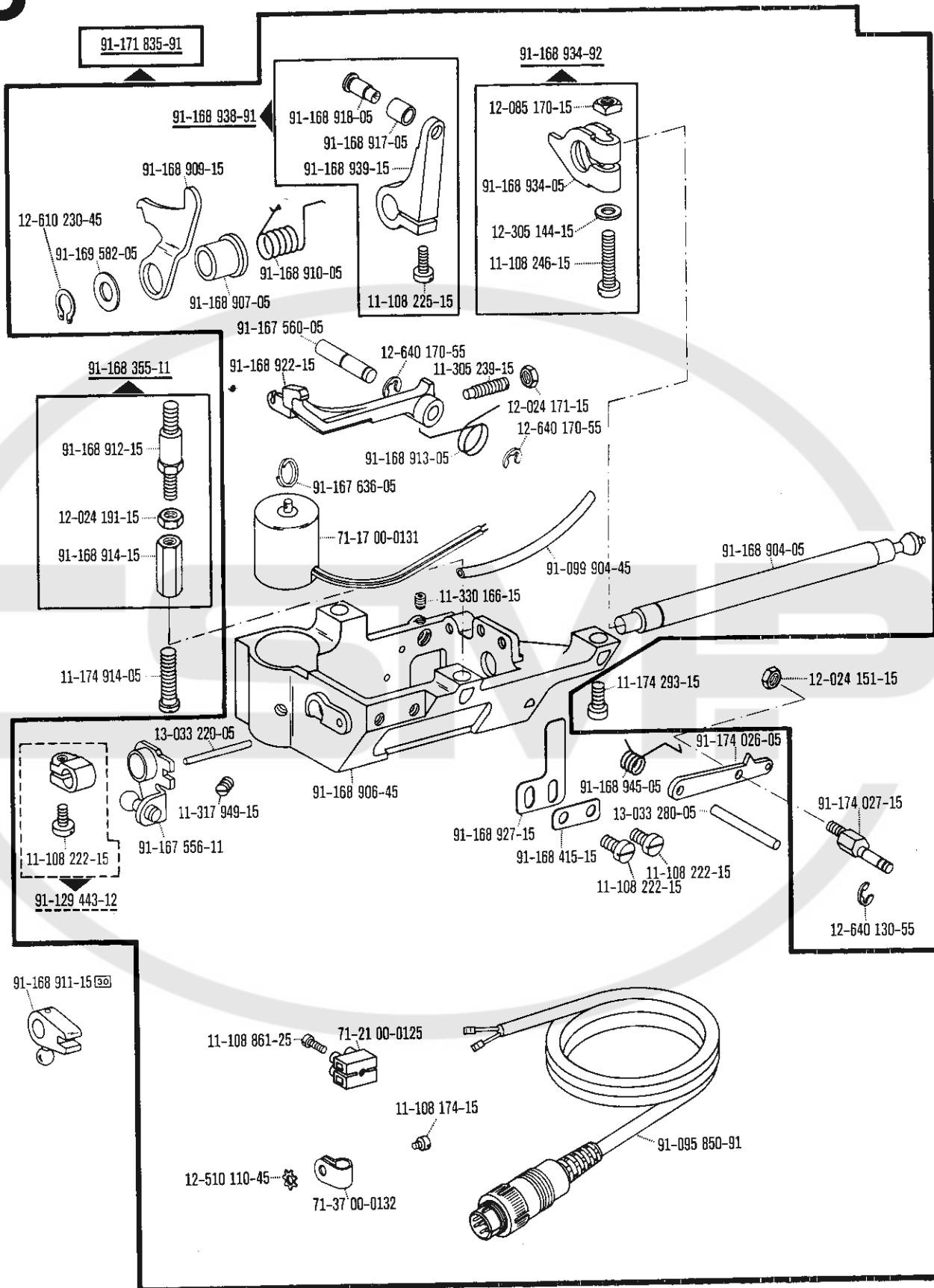

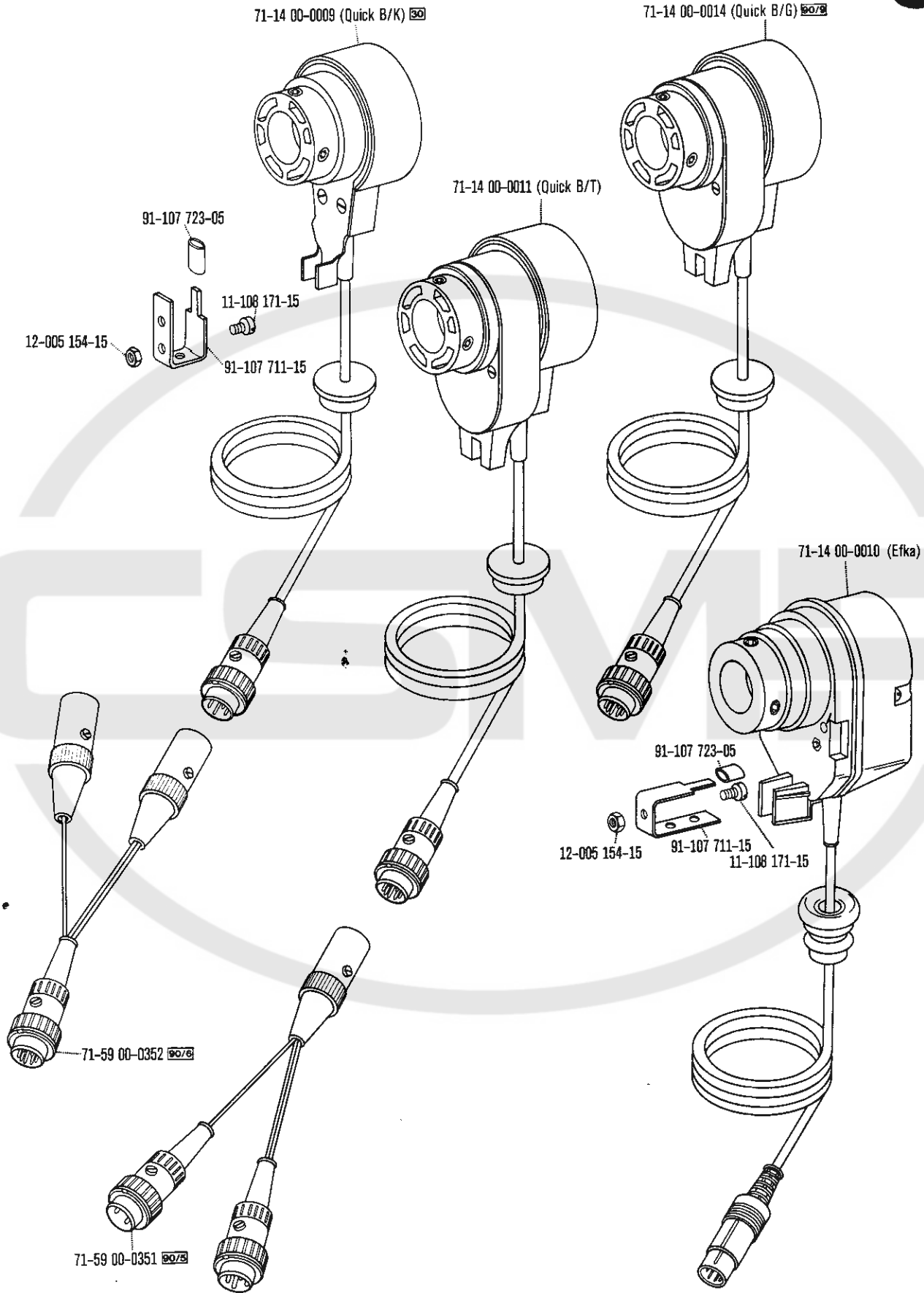

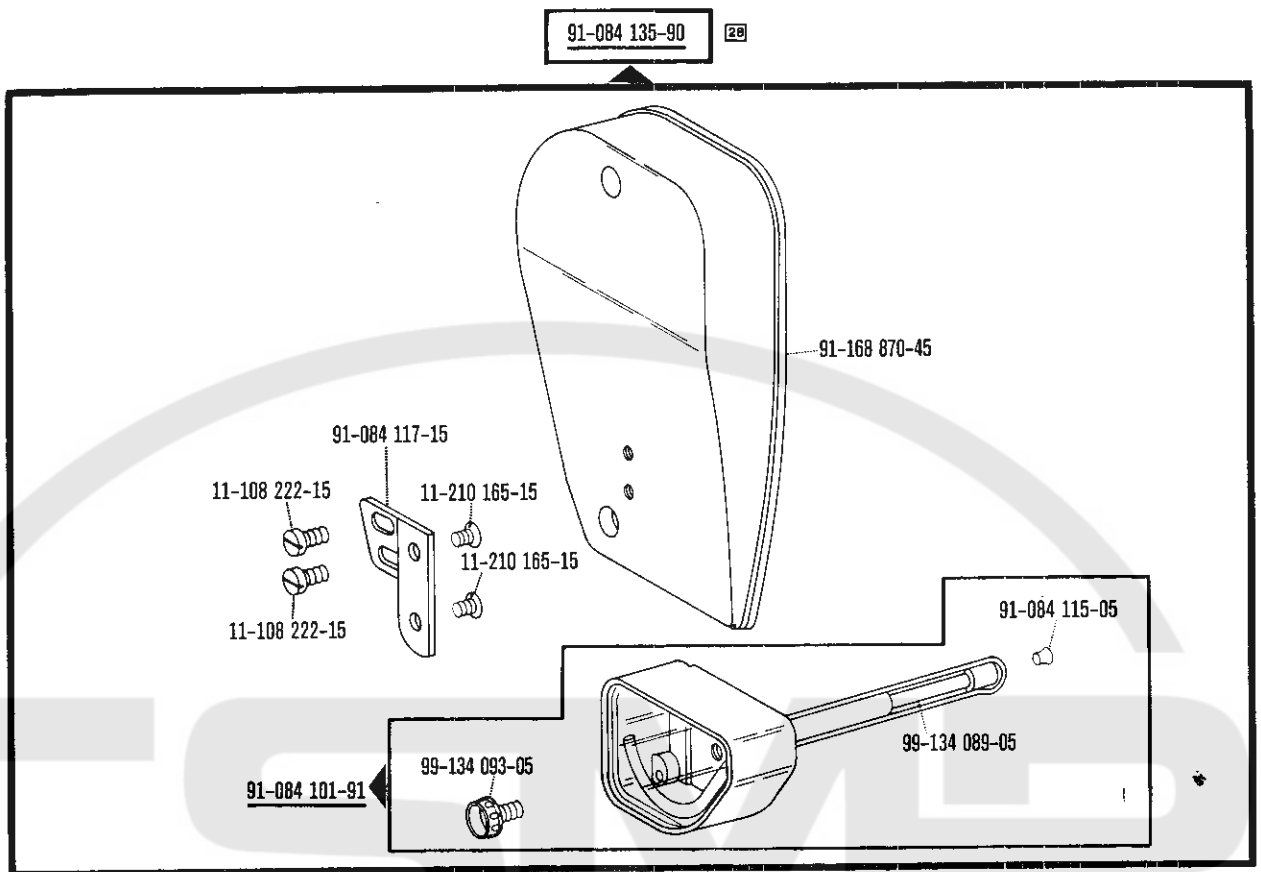

Pfaff 417/419-900/...-909/03

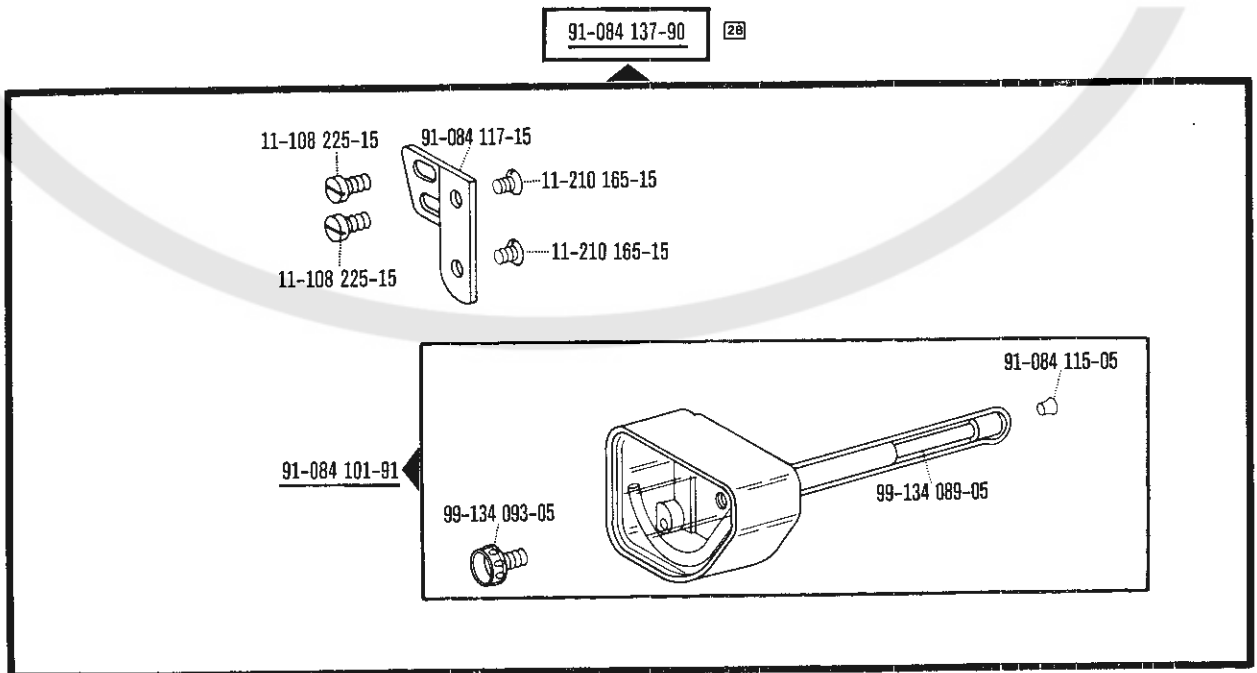

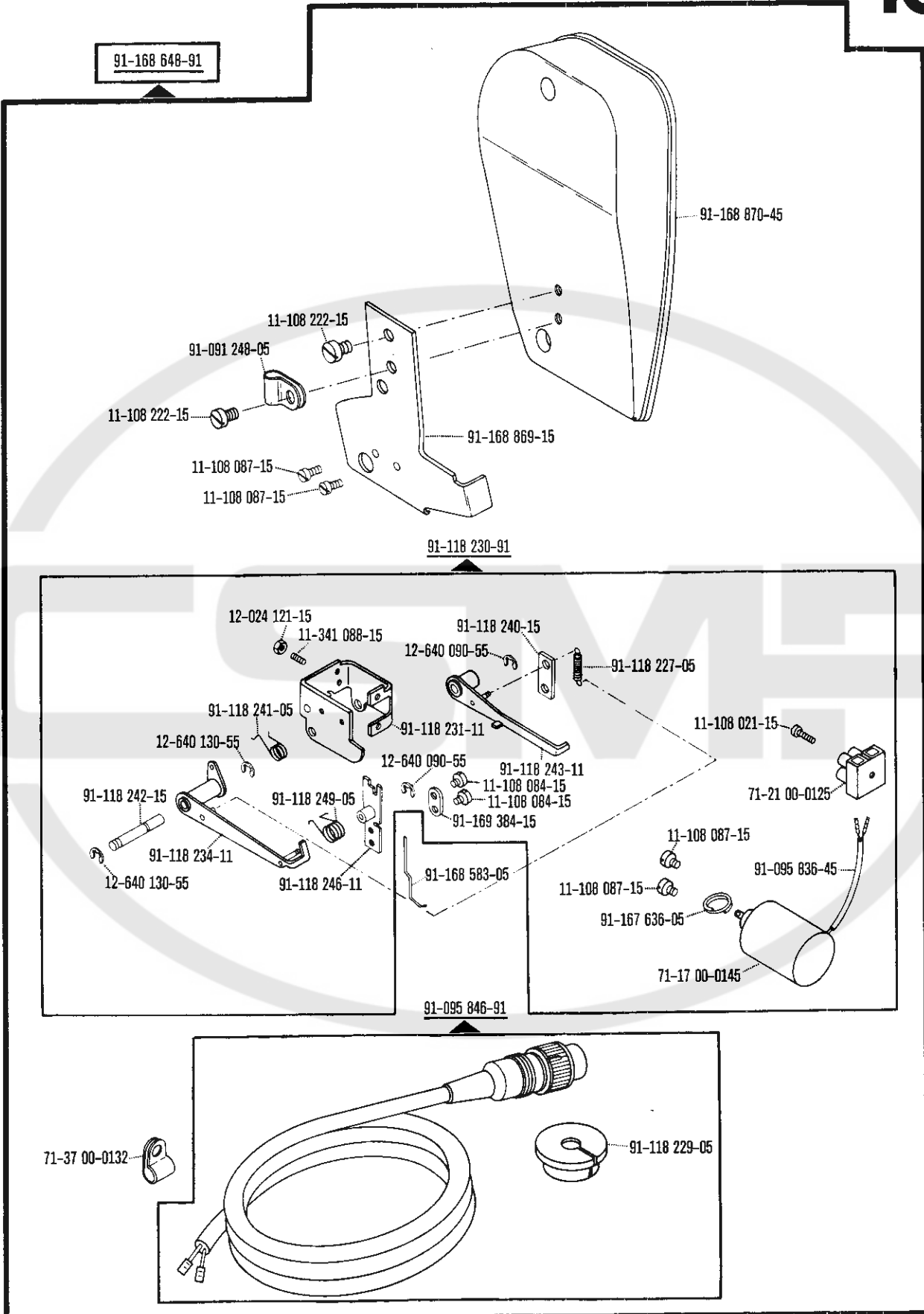

71-59 00-0242 (Quick-PFA 54)

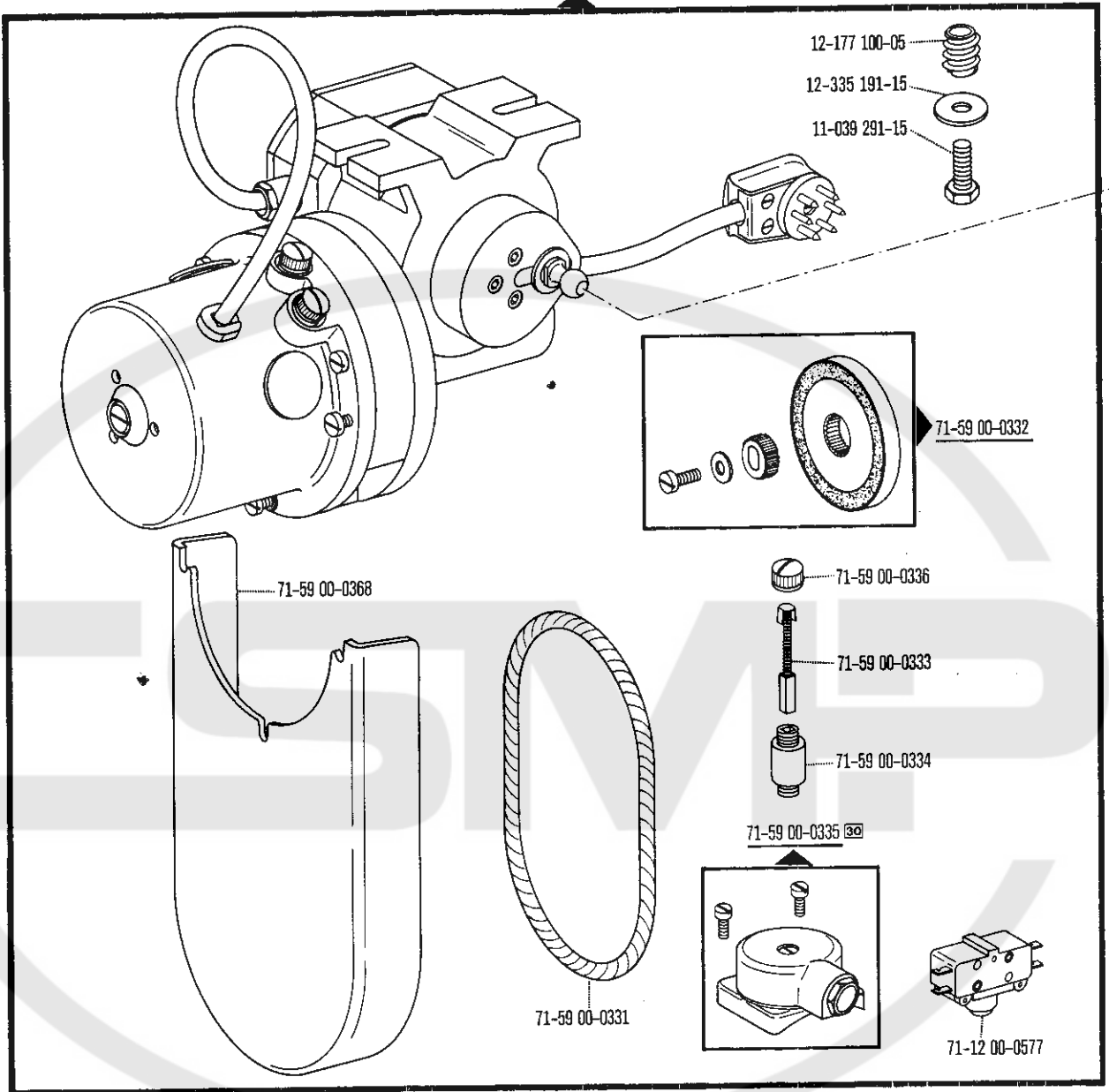

71-59 00-0265 (Quick)

71-59 00-0264 (Pfaff)

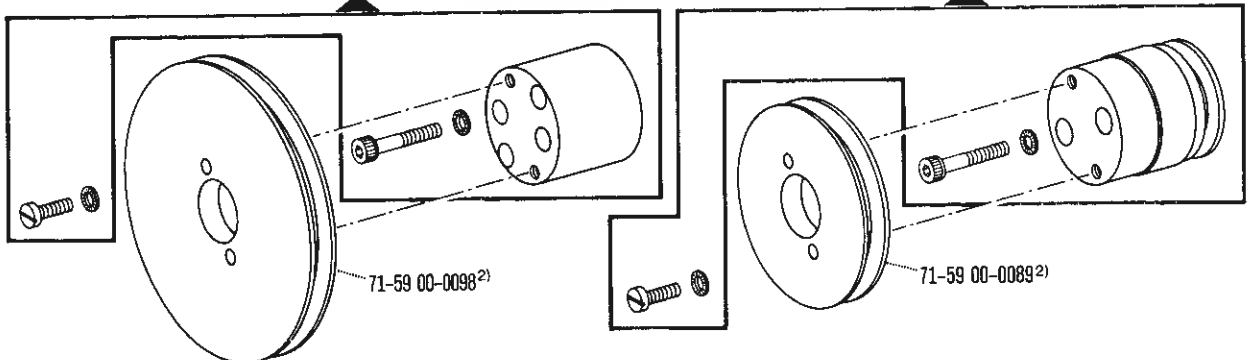

48 ²⁾ siehe Schnurscheiben-Tabelle Seite 49
see Table of pulleys on page 49
voir page 49 tableau des poulies à gorge

00-000 000-00 00-000 000-00 00-000 000-00 siehe Erläuterungen Seite 5
see explanations on page 7
voir légende page 9
ver explicaciones de la página 11

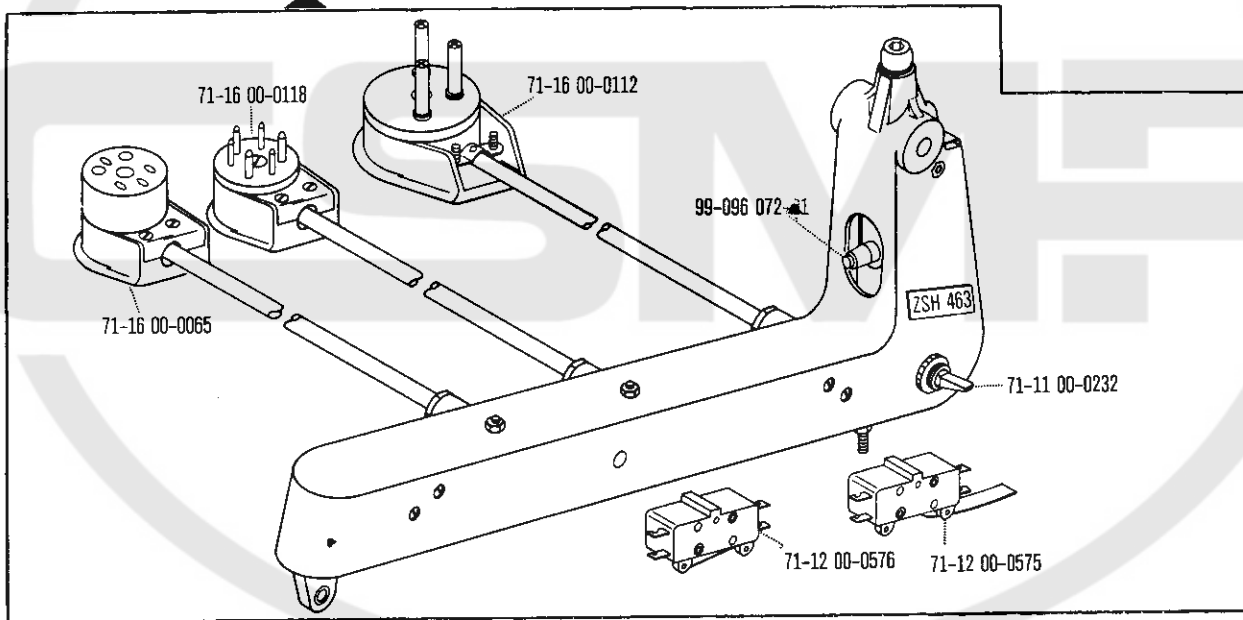
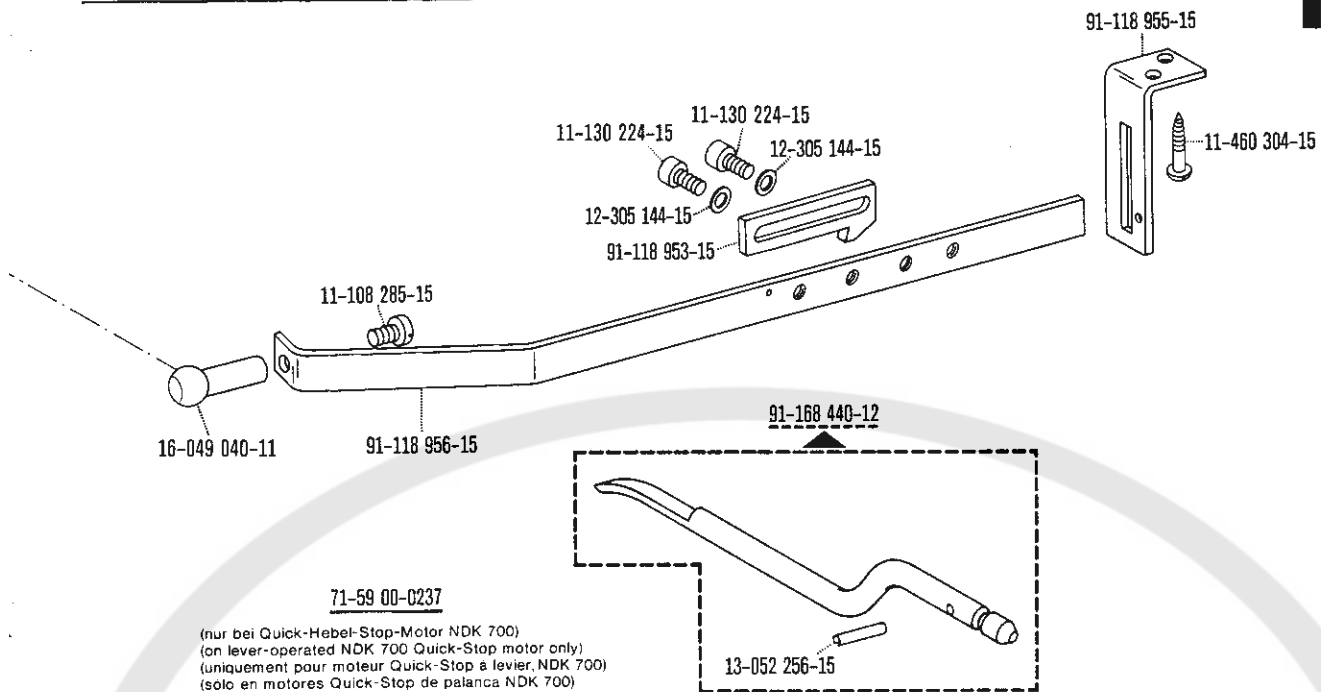

Schnurscheiben-Tabelle · Table of Pulleys

Tableau des poulies à gorge · Tabla de poleas acanaladas

Teilenummer Part number Numéros des pièces № de las piezas	Motordrehzahl U/min. Motor speed (r. p. m.) Régime moteur trs/mn Régimen del motor en r. p. m.	Frequenz Frequency Fréquence Frecuencia	Schnurscheiben-Durchmesser ¹⁾ in mm Pulley dia. ¹⁾ (mm) Diamètre effectif de la poulie en mm Diámetro efectivo de la polea en mm
71-59 00-0098	1400	50 Hz (c/s)	86
	1700	60 Hz (c/s)	86
71-59 00-0089	2800	50 Hz (c/s)	56
	3400	60 Hz (c/s)	56

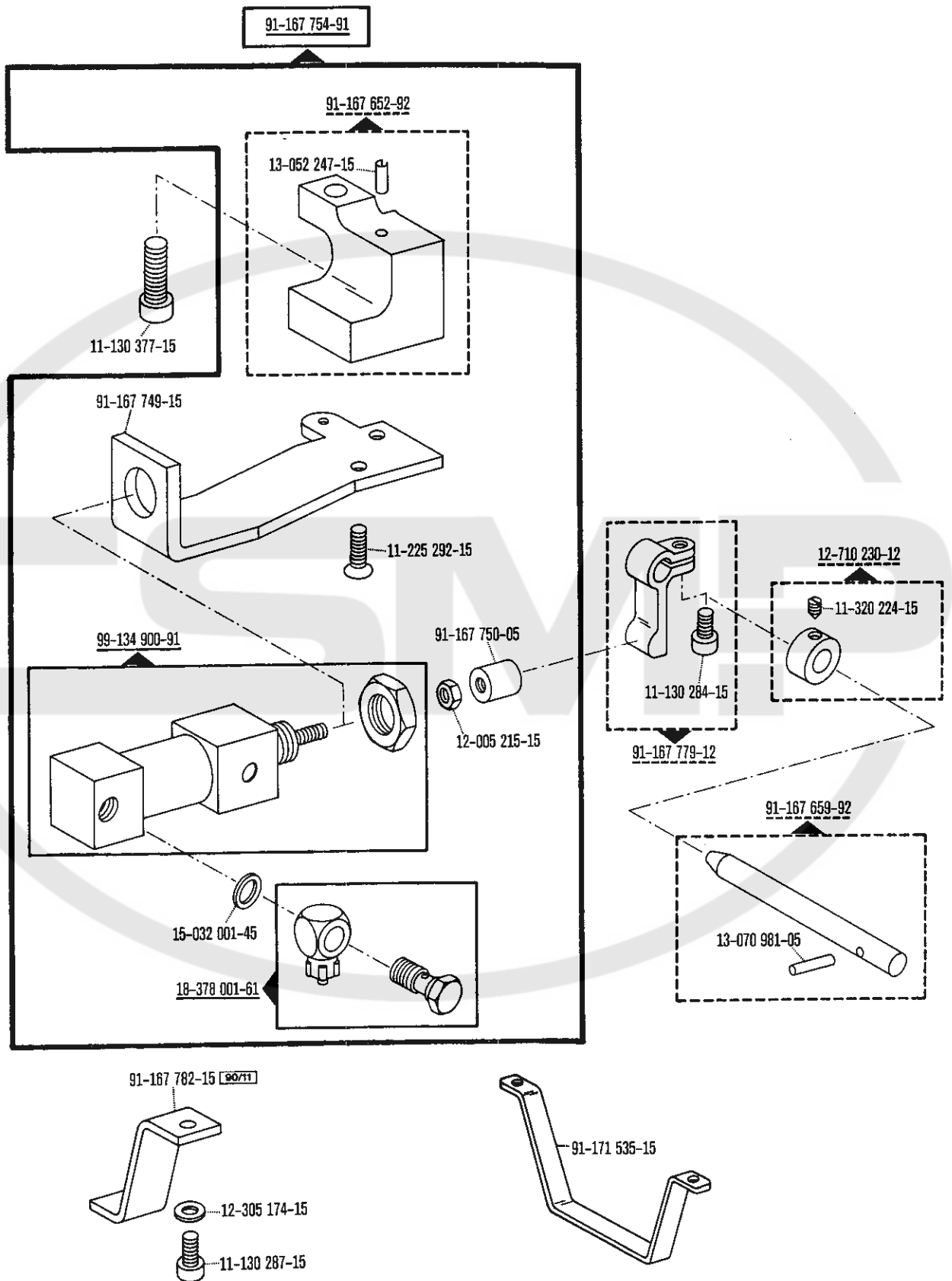

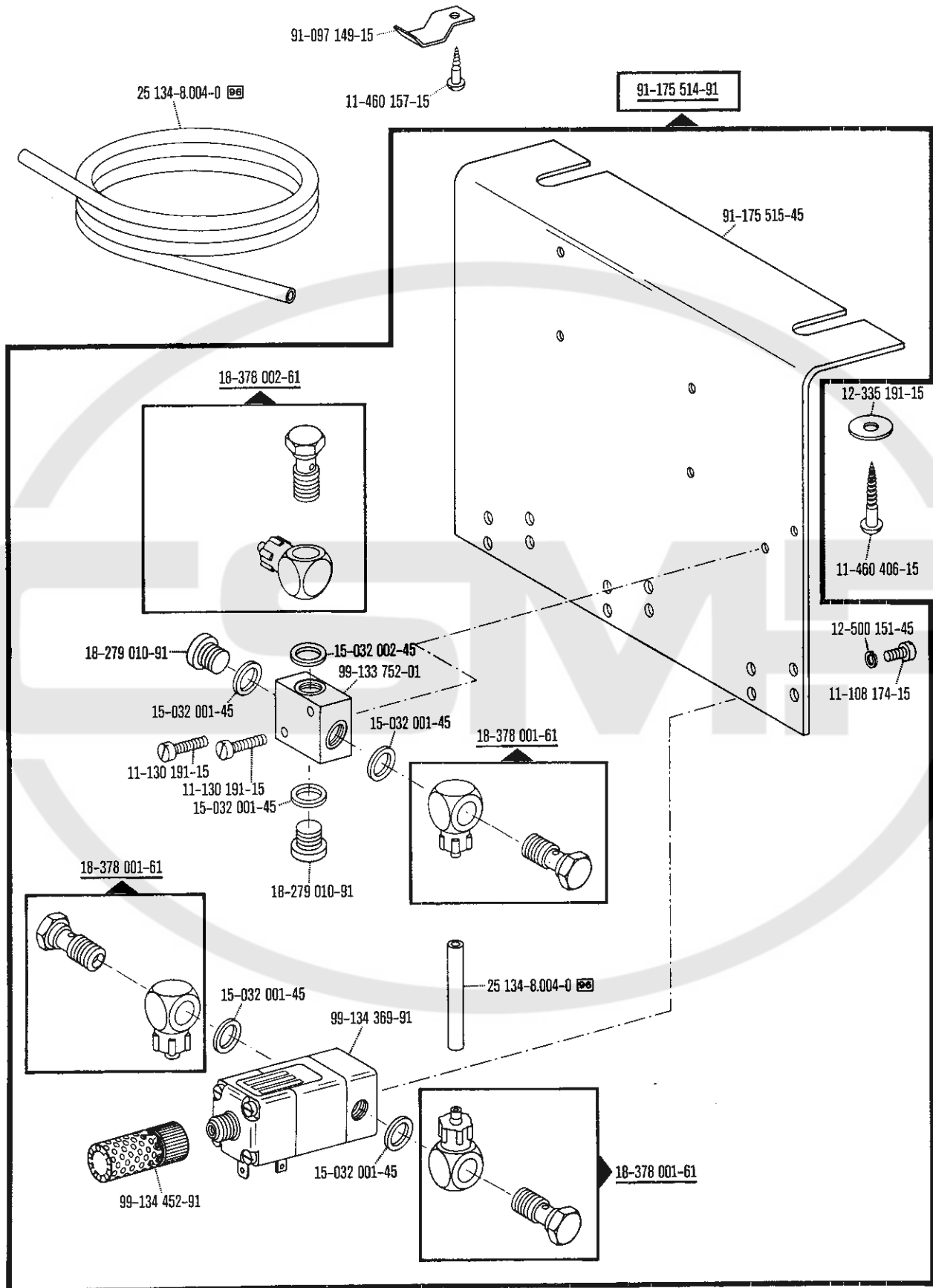

91-095 829-91

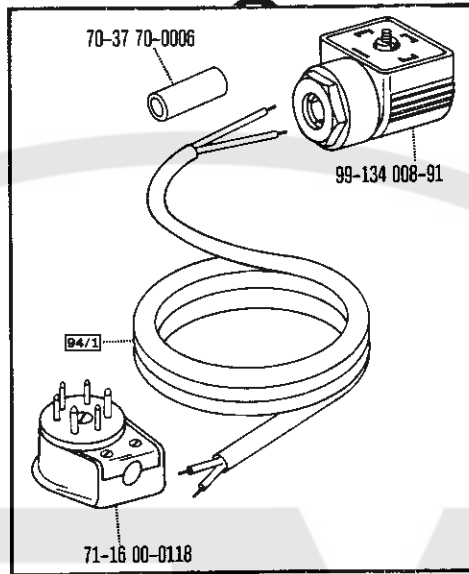

71-59 00-0237

(nur bei Quick-Hebel-Stop-Motor NDK 700)
 (on lever-operated NDK 700 Quick-Stop motor only)
 (uniquement pour moteur Quick-Stop à levier, NDK 700)
 (sólo en motores Quick-Stop de palanca NDK 700)

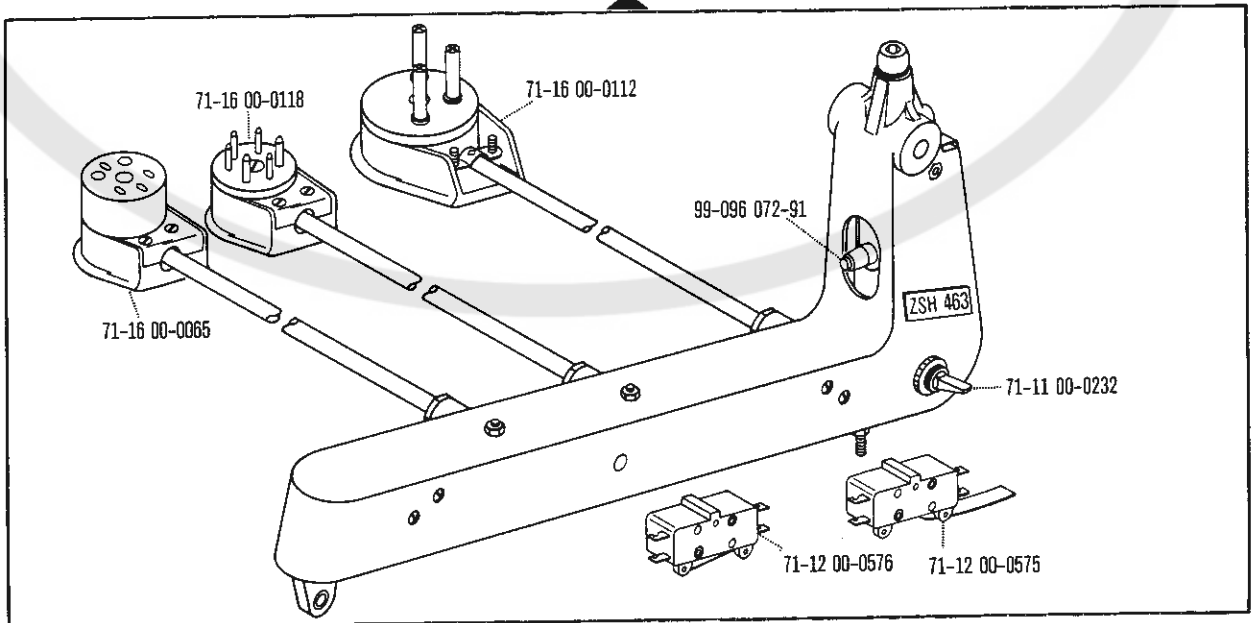

91-170 783-91

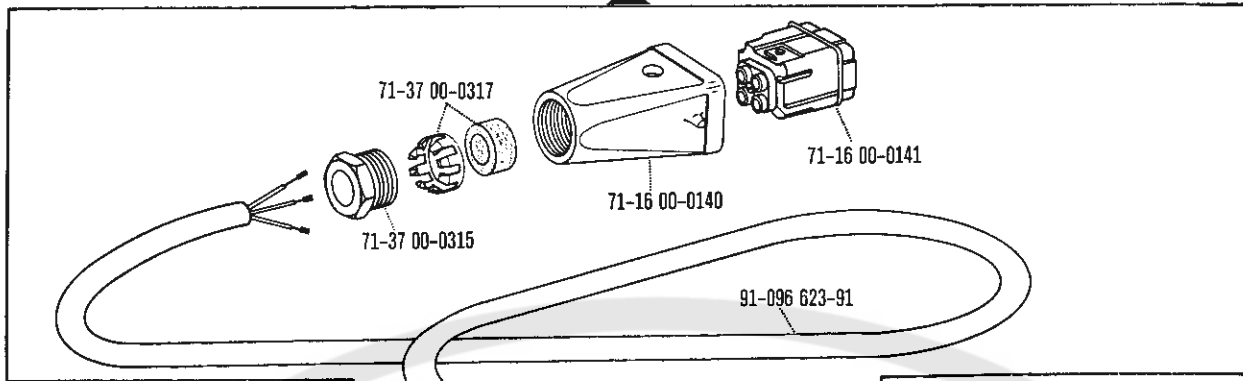

71-37 00-0133

91-099 811-05

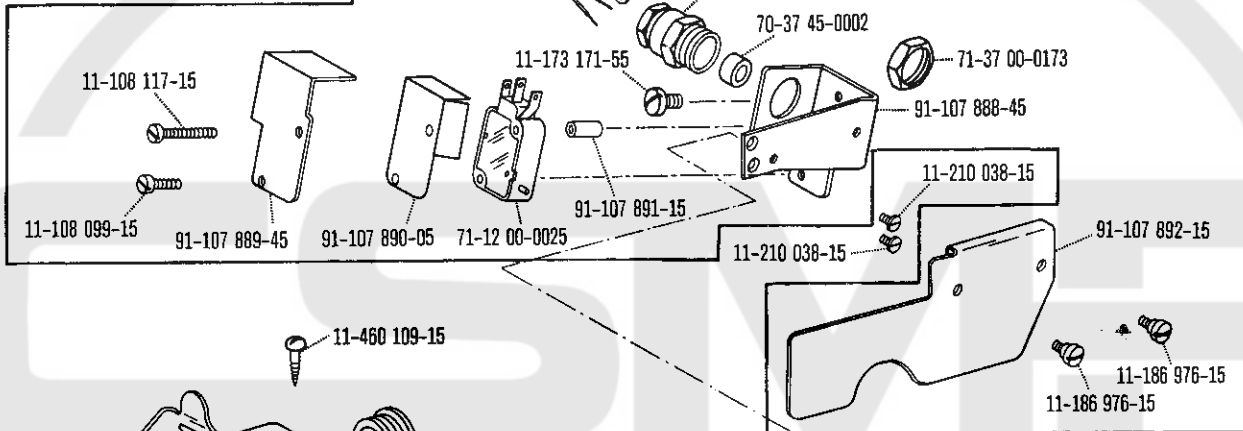

11-460 109-15

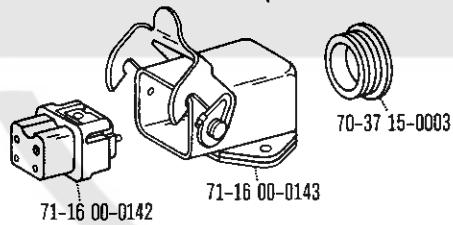

91-171 627-45

91-100 270-15

91-032 477-91

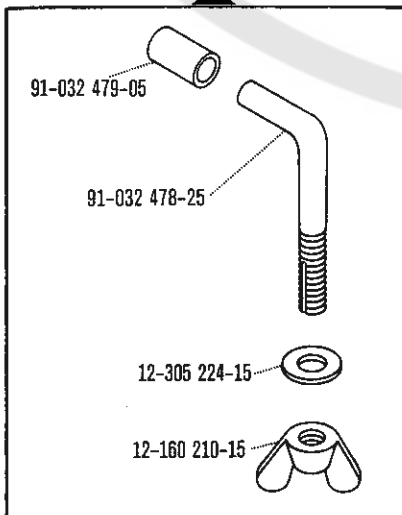

91-168 644-15

91-167 541-12

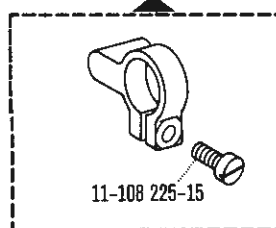

11-039 354-15

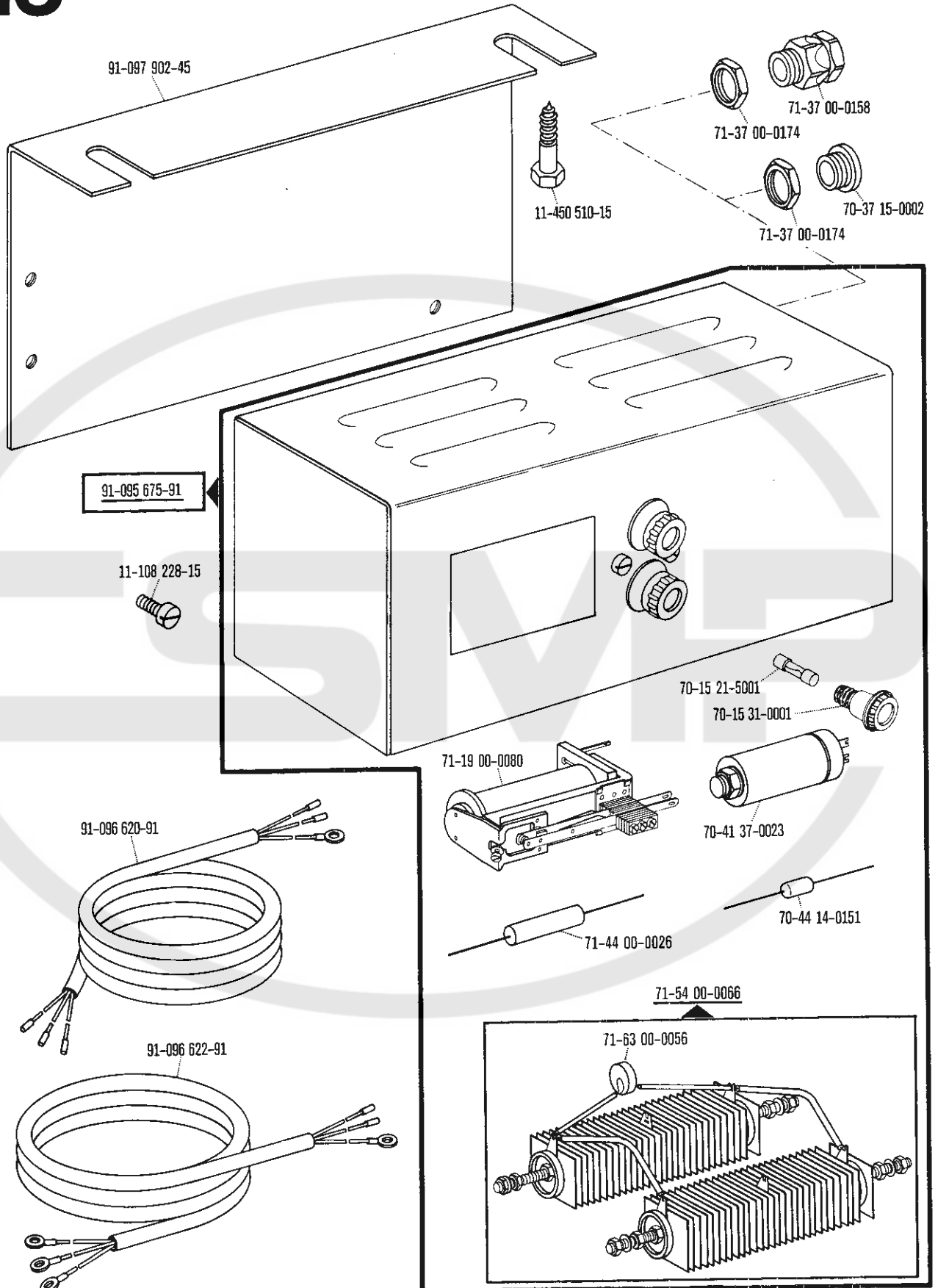

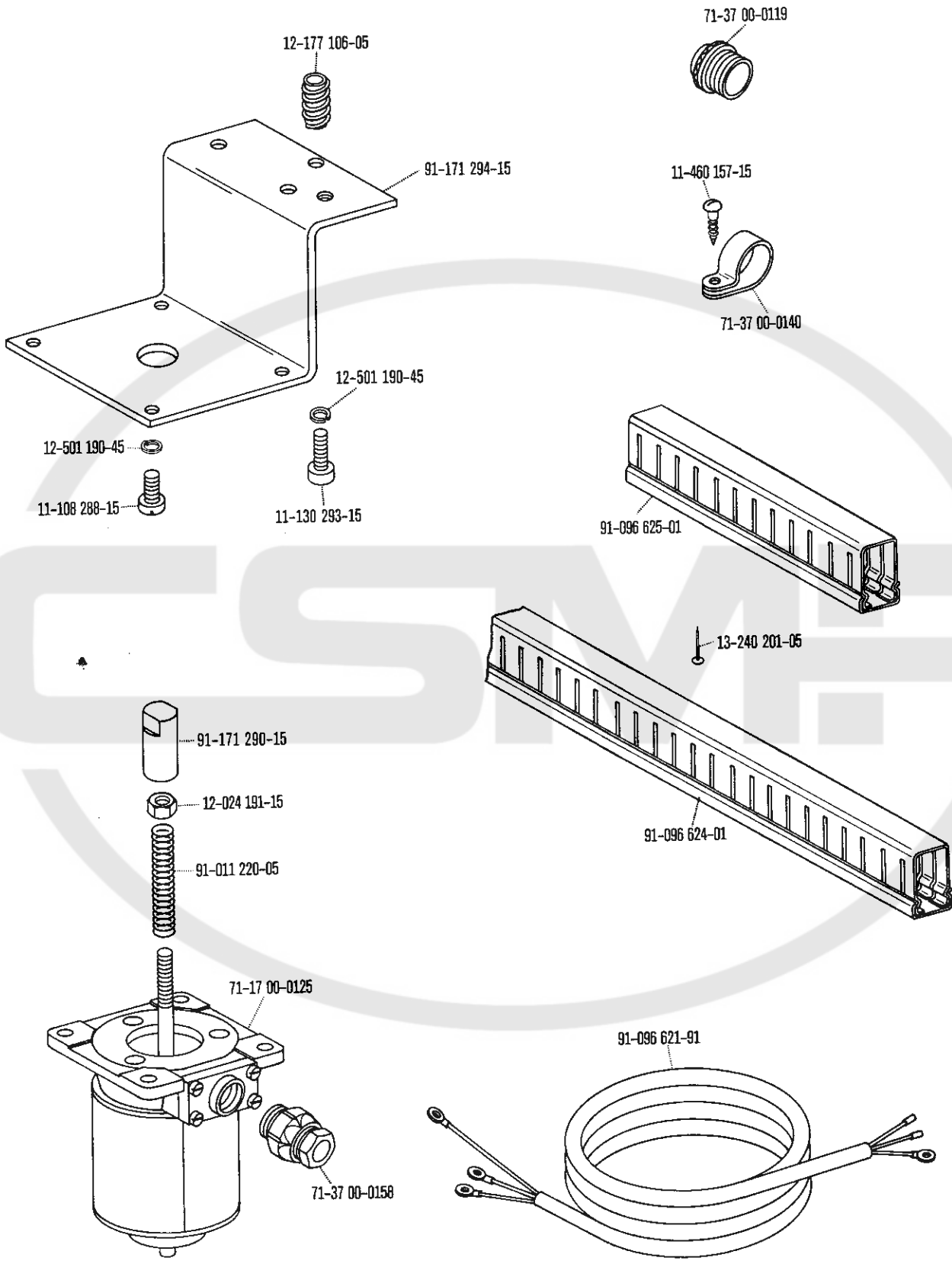

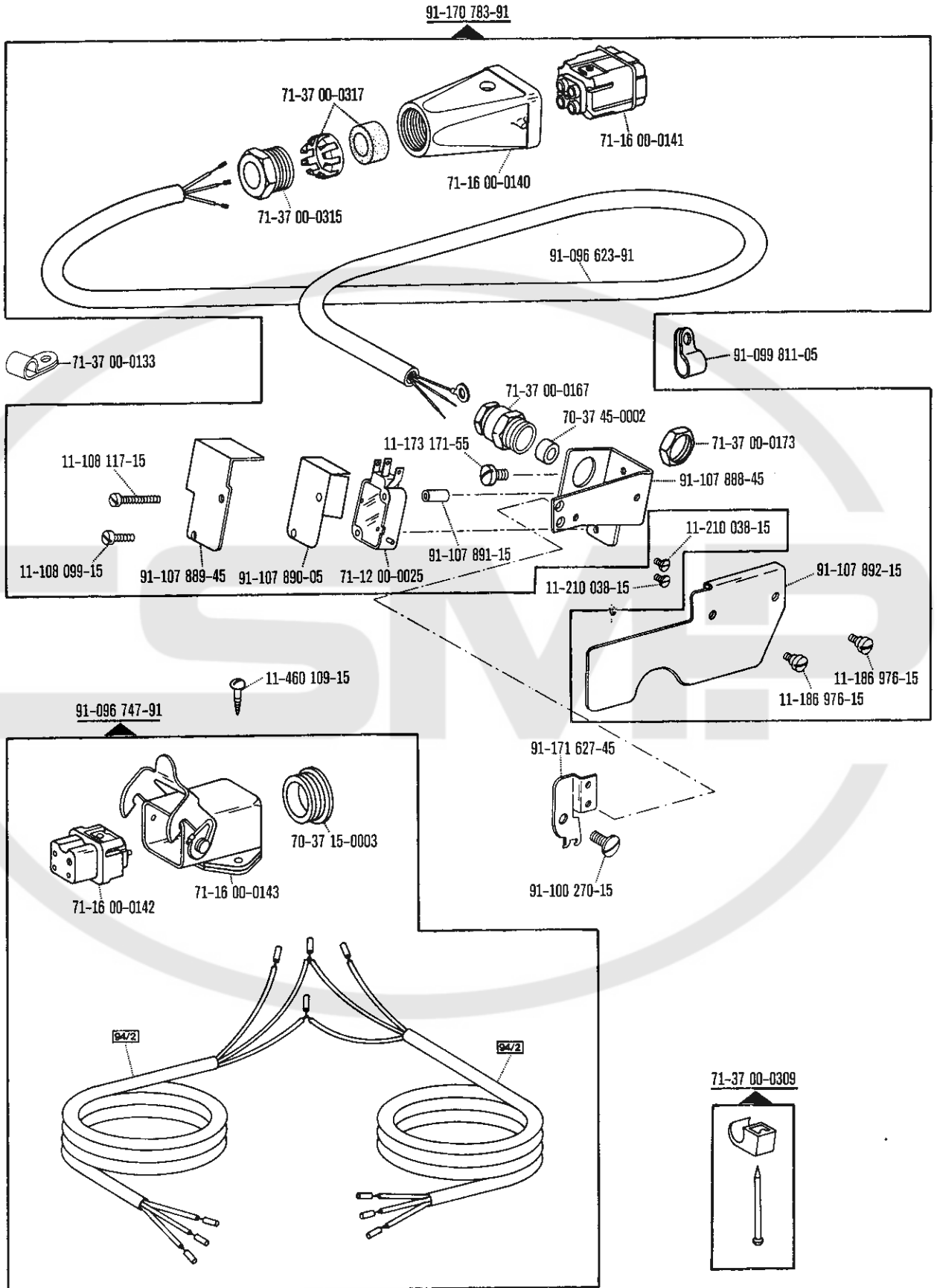

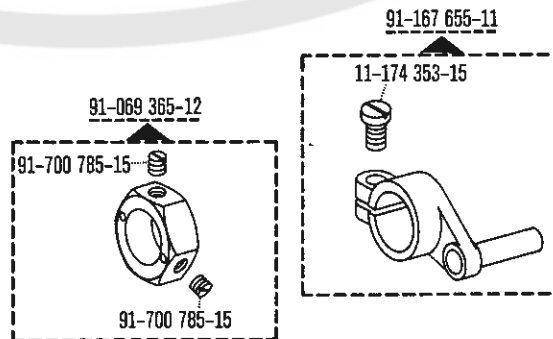
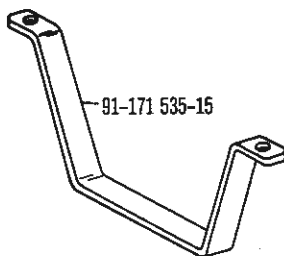
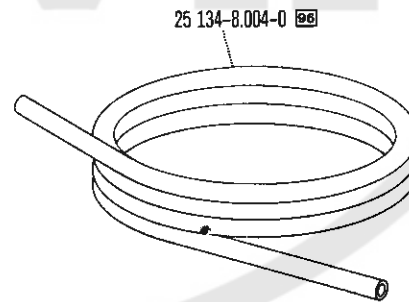
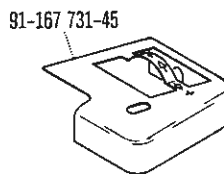
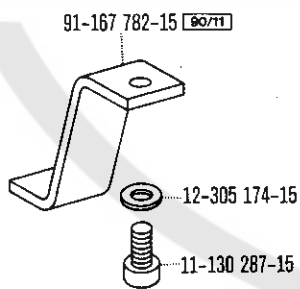
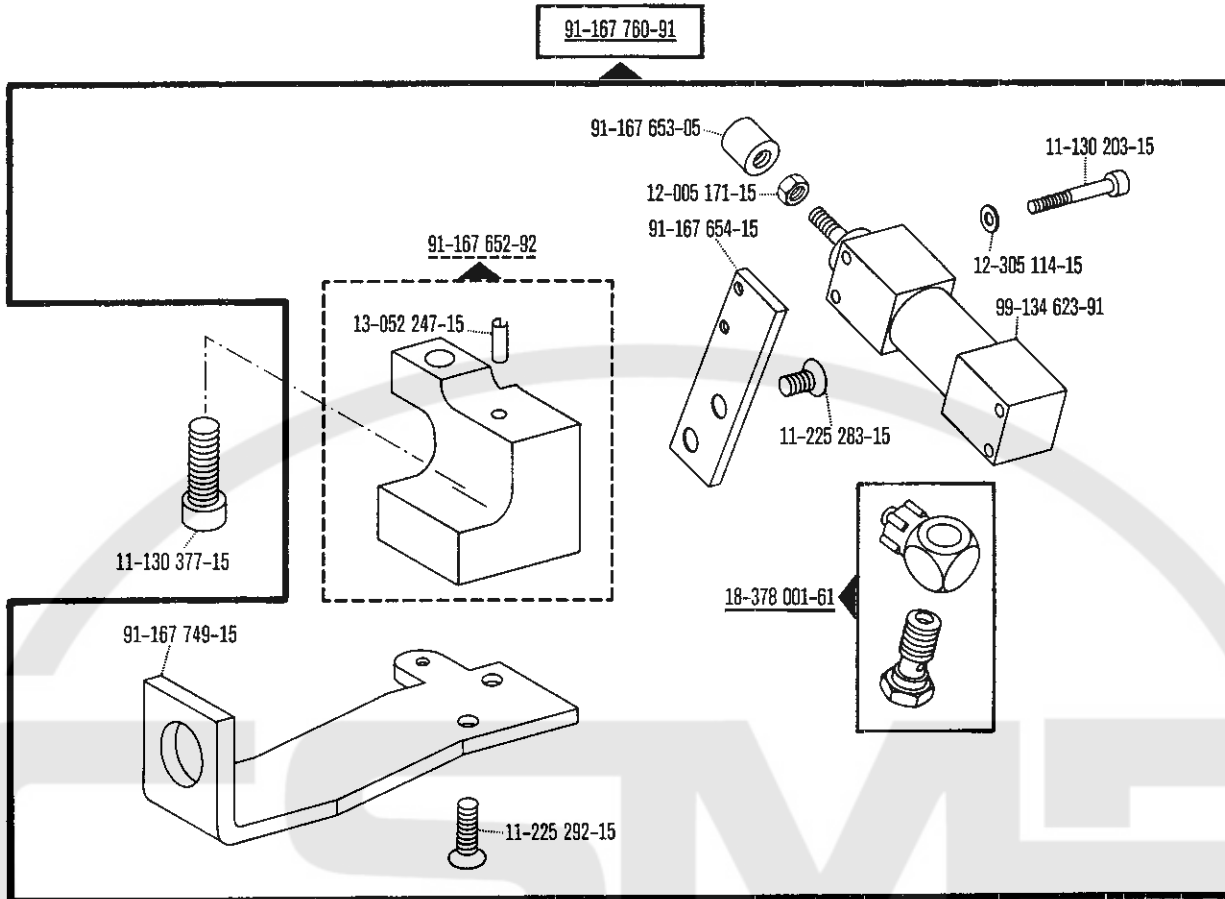

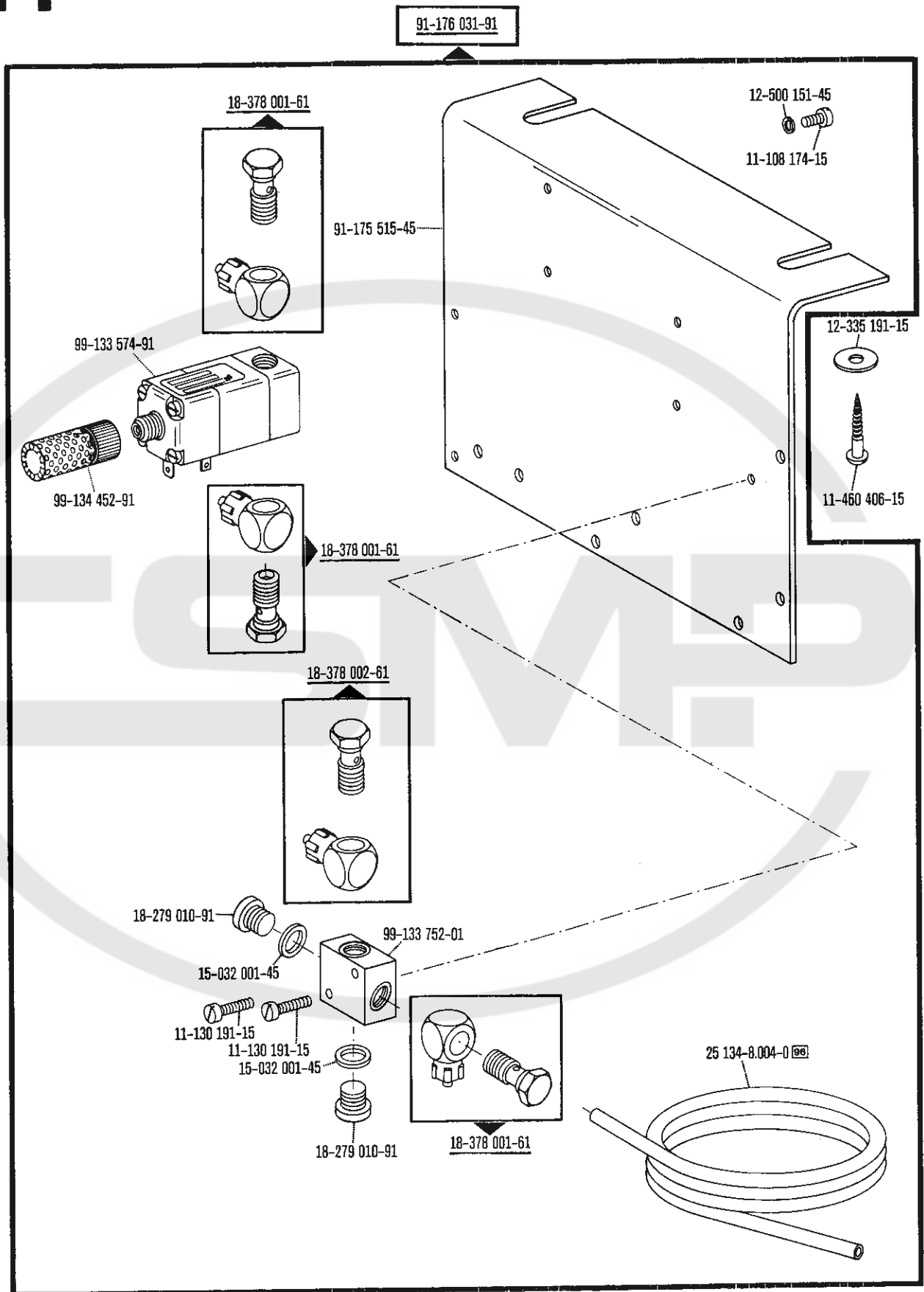

91-167 768-91

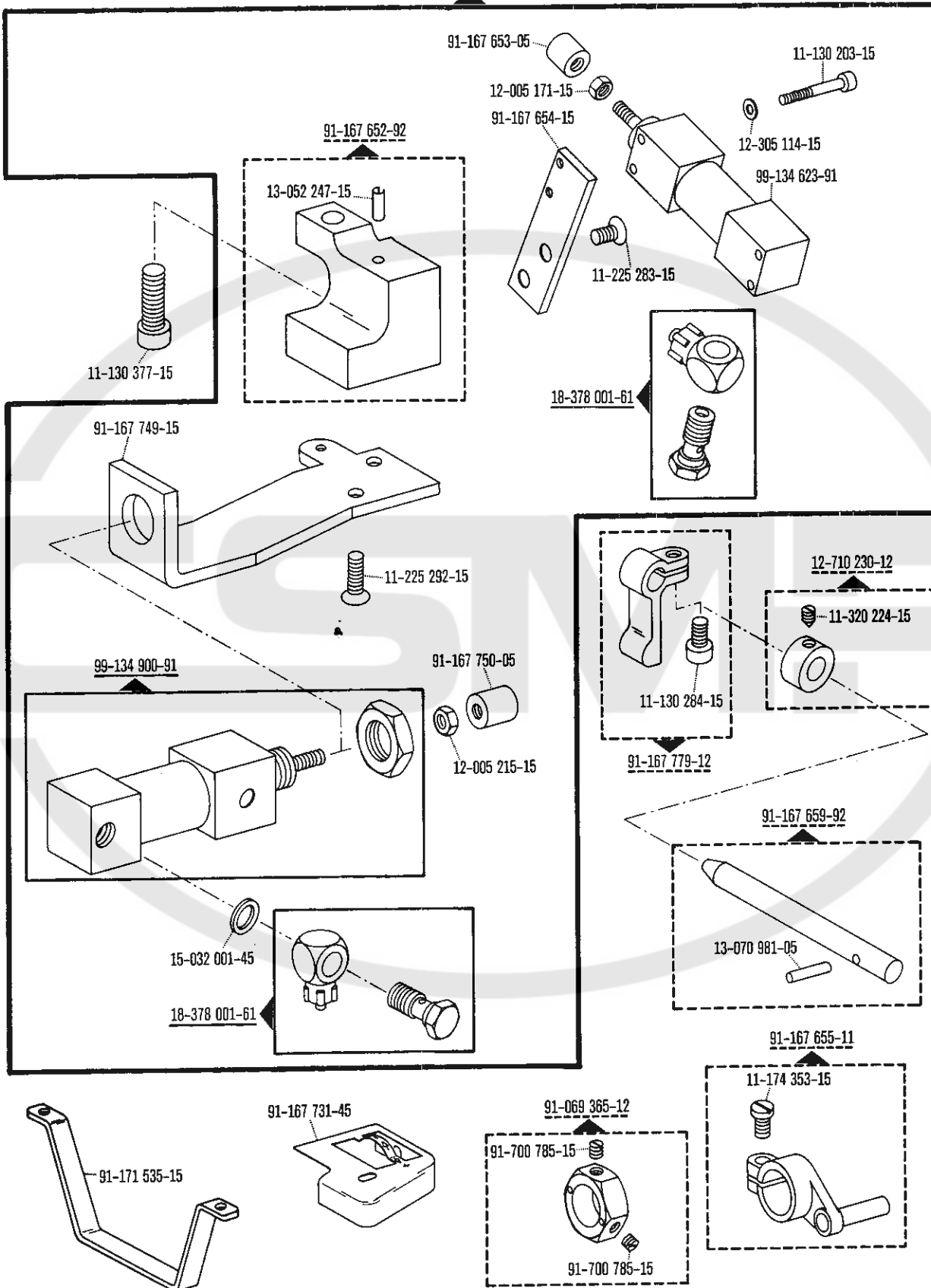

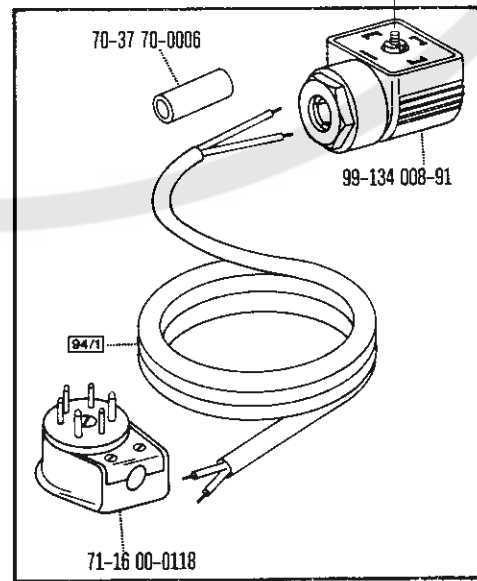
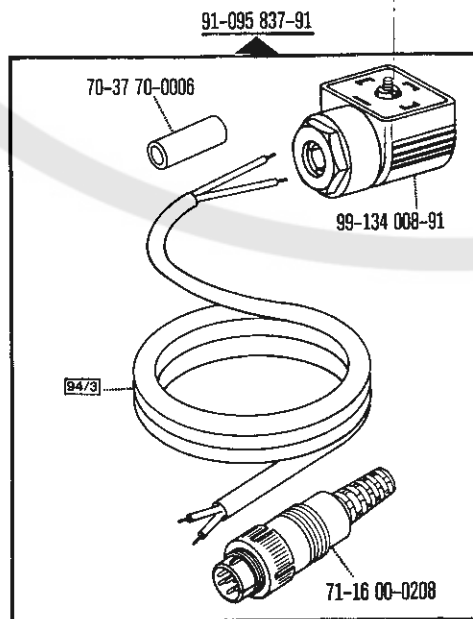
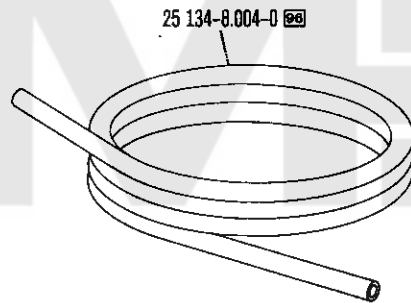
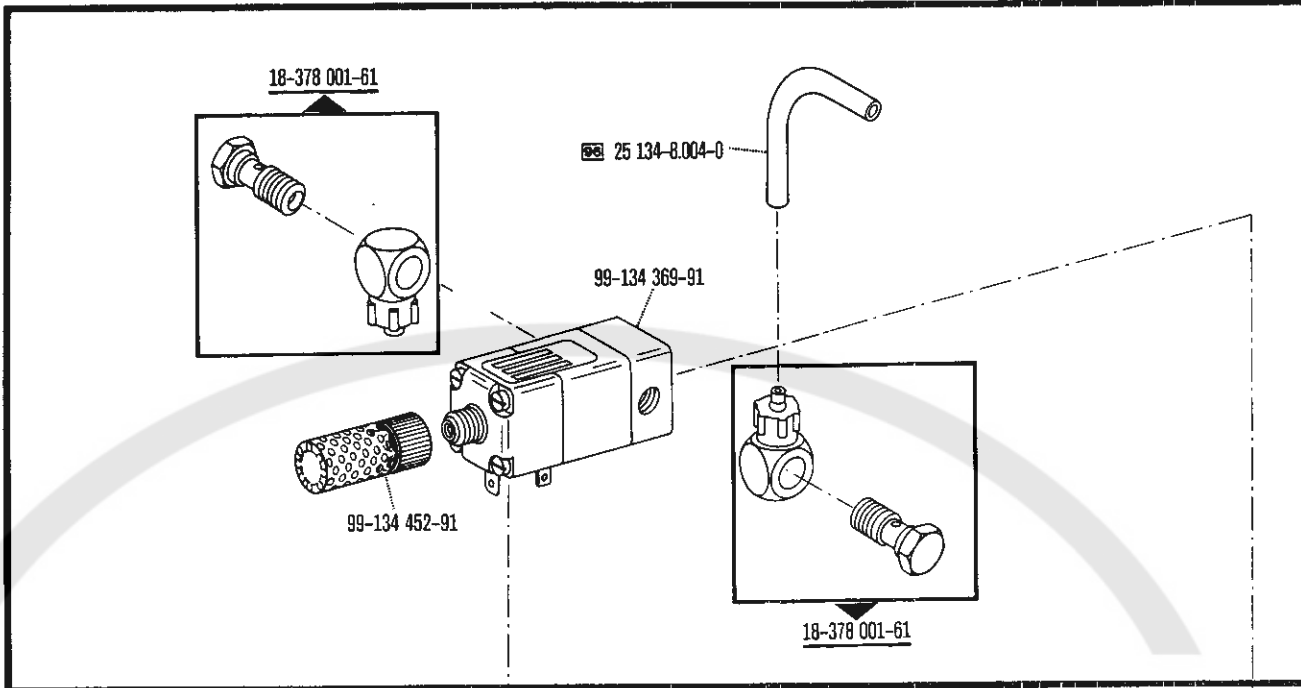

91-095 829-91

91-176 051-91

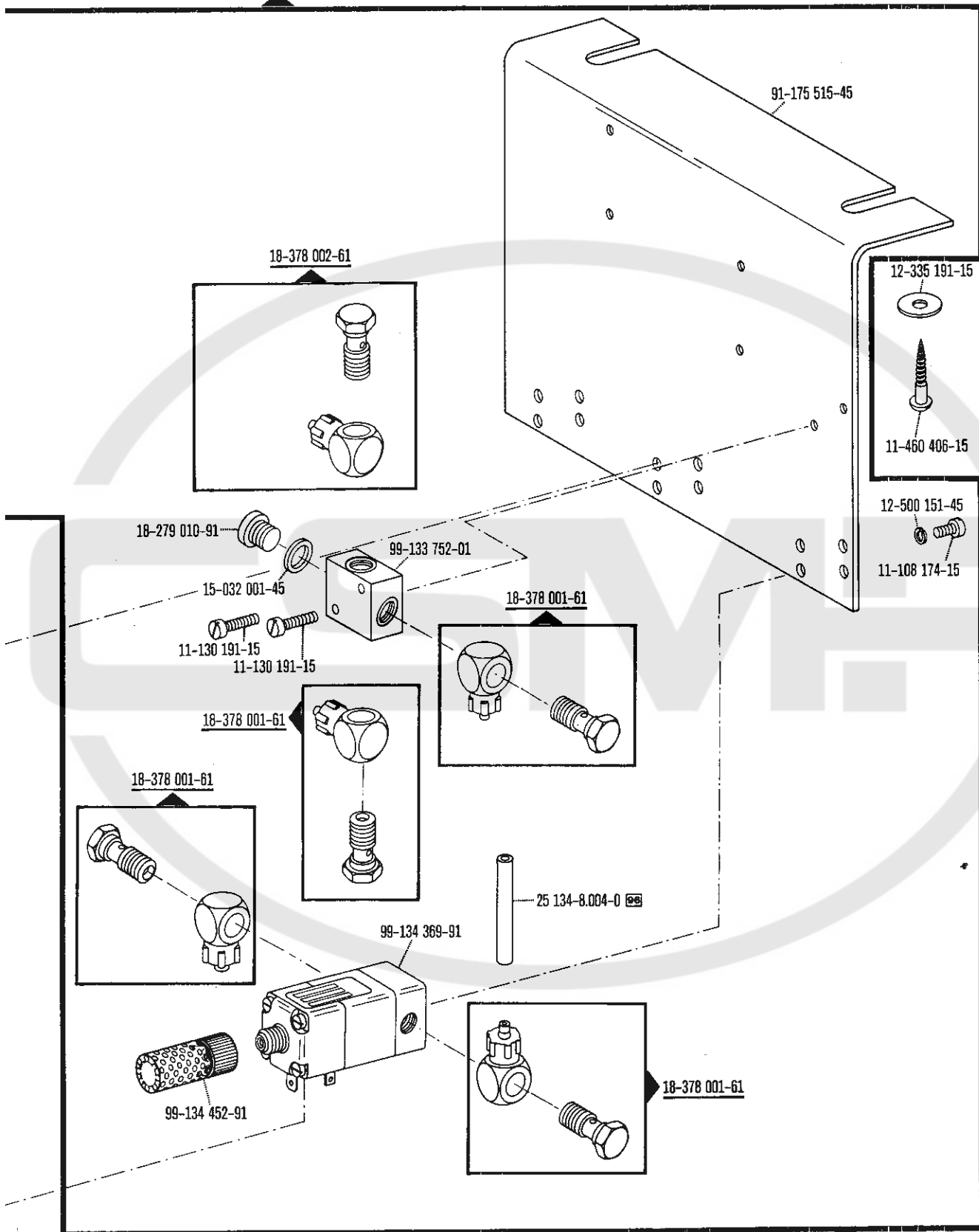

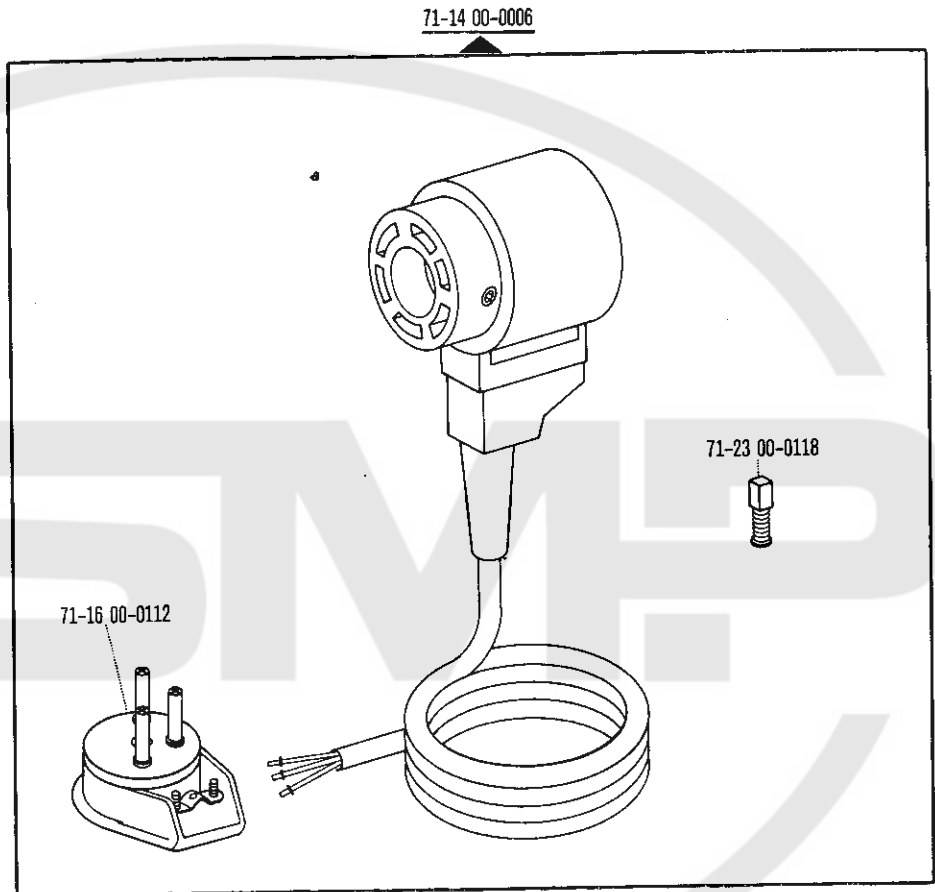

71-59 00-0259 90/7 90/8

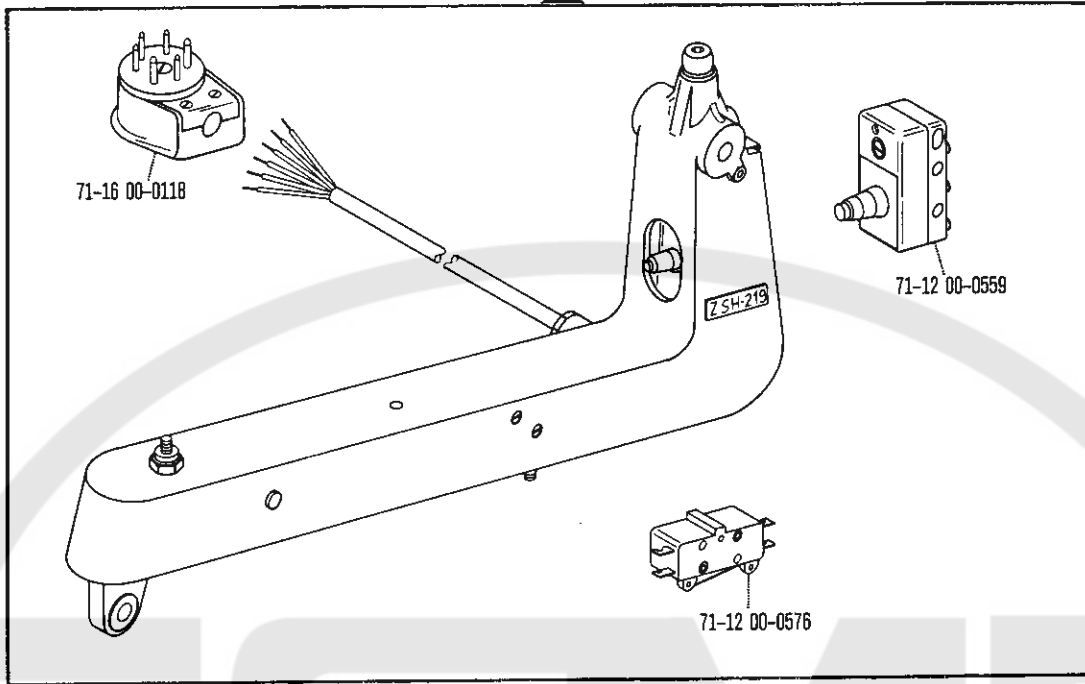

71-59 00-0268 90/7 90/8

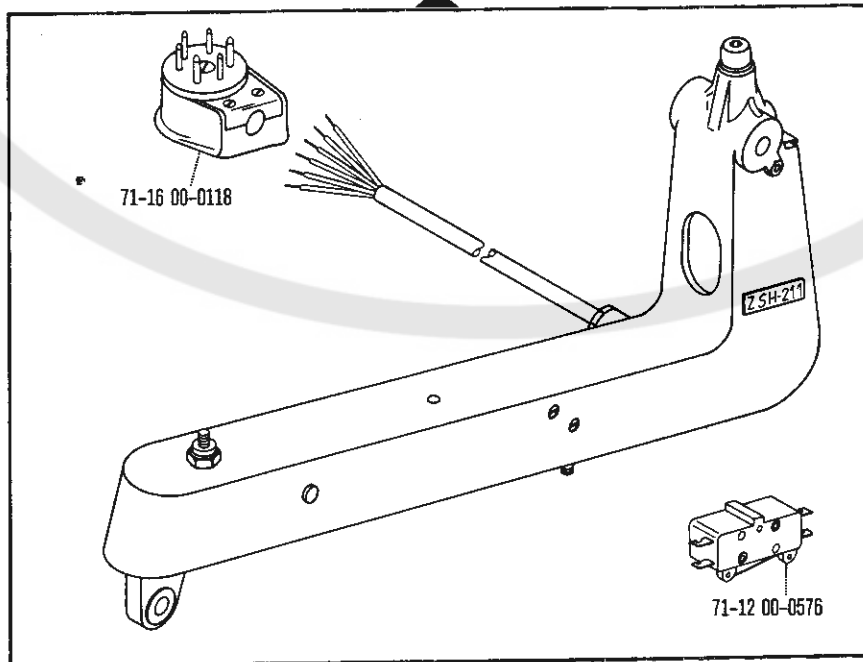

91-168 867-90

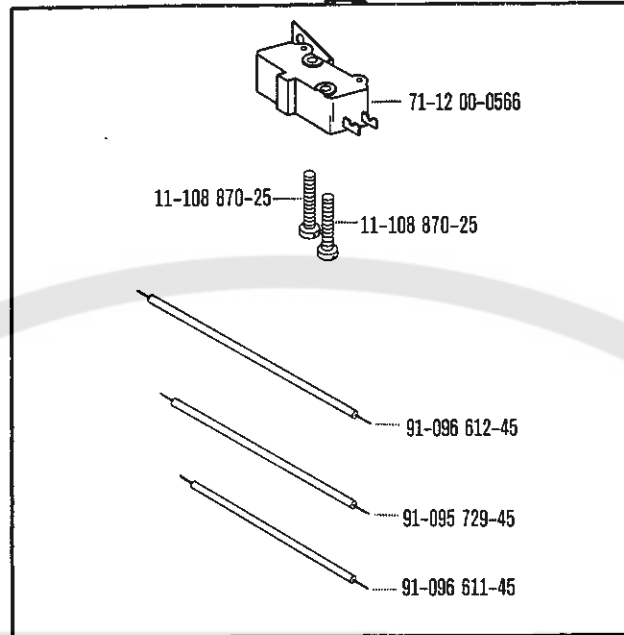

-913/04 zur · pour la for · para la Pfaff 417/419-900/51

91-090 700-90

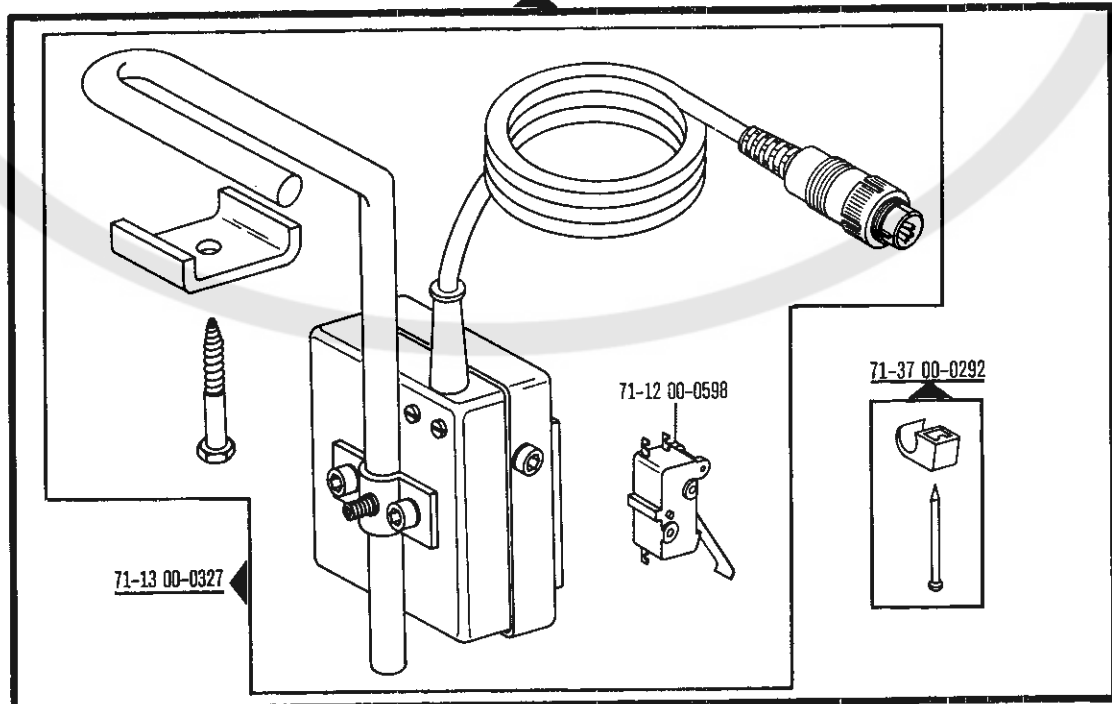

91-091 331-91

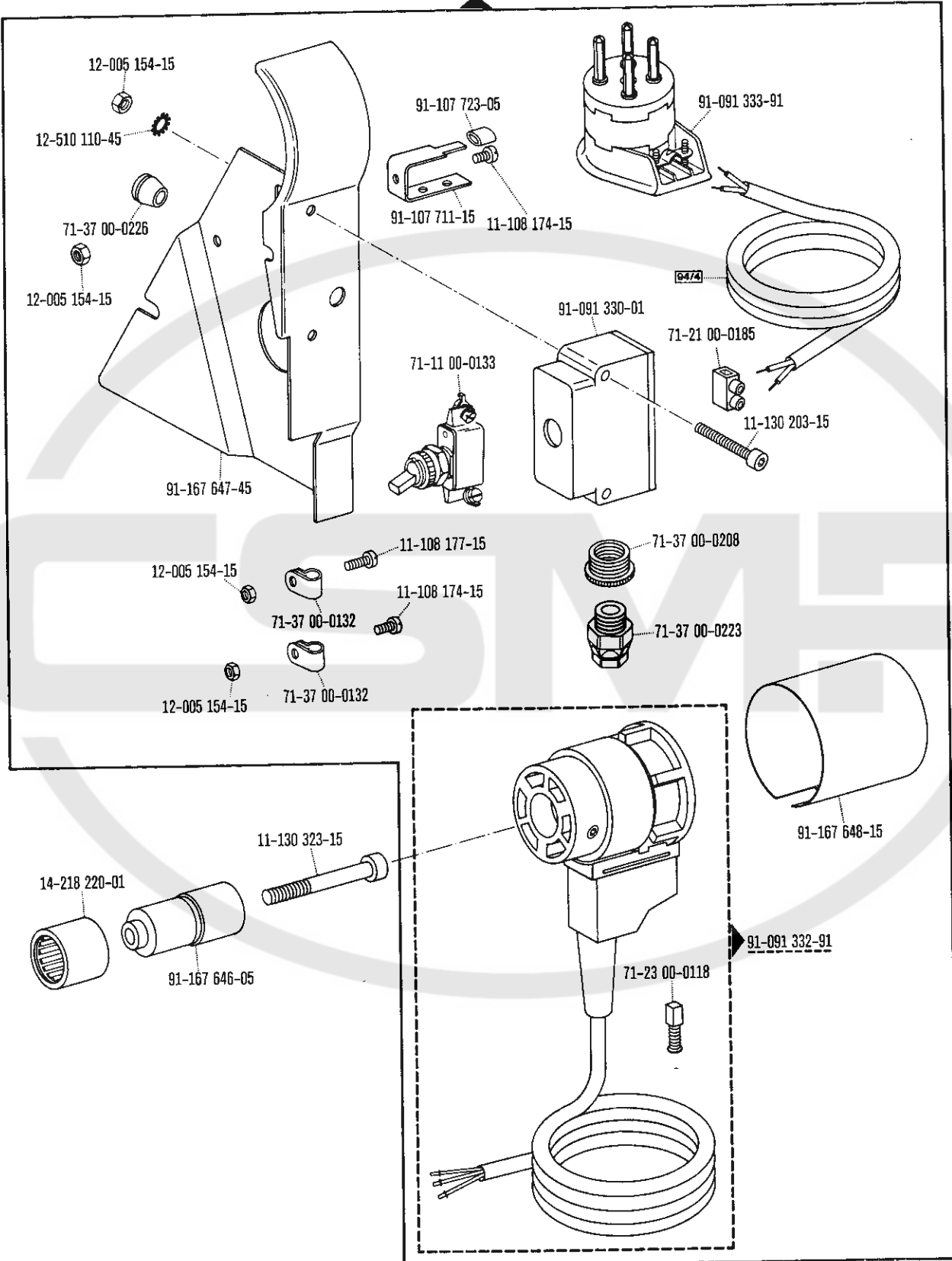

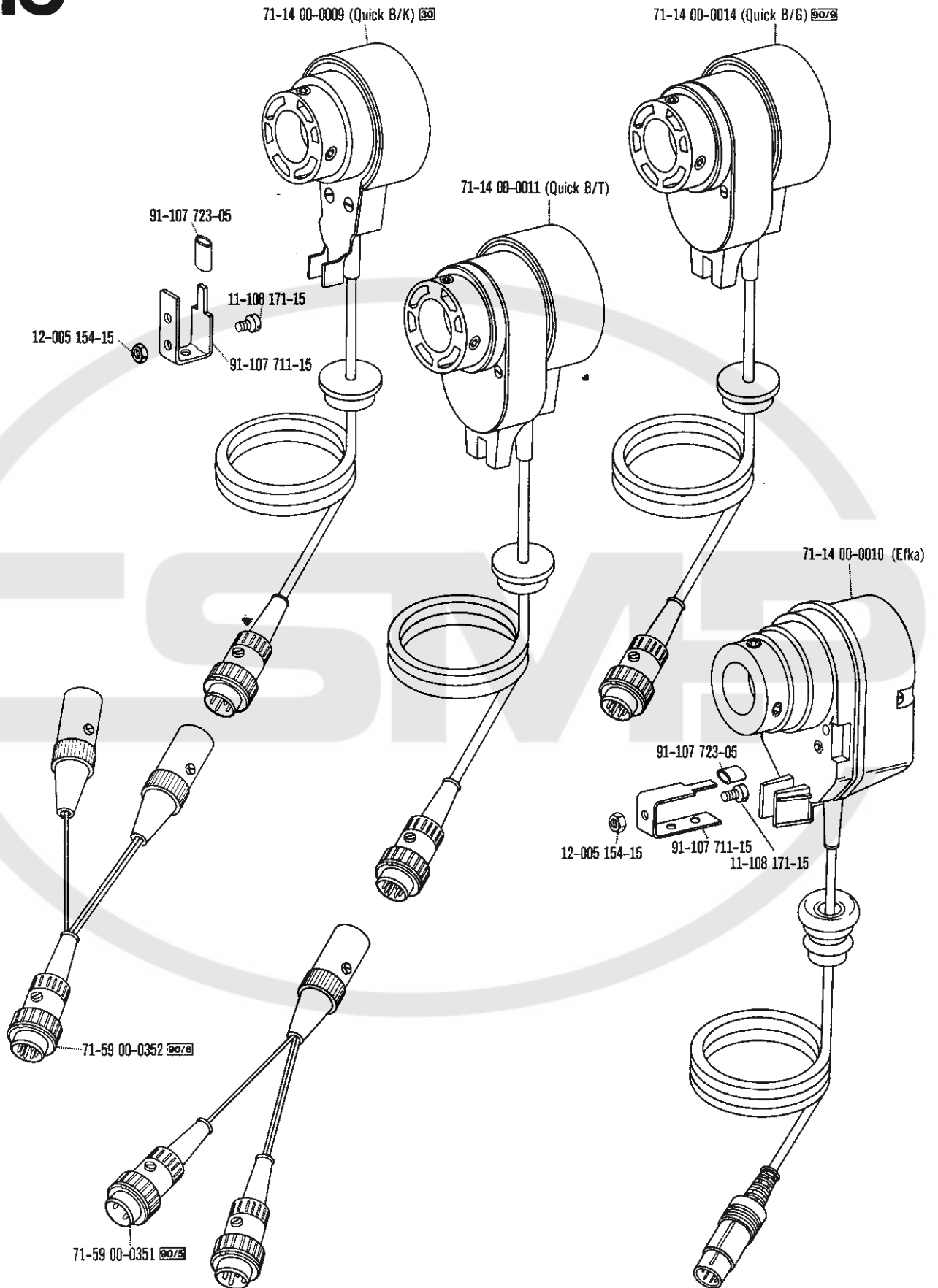

91-171 462-90

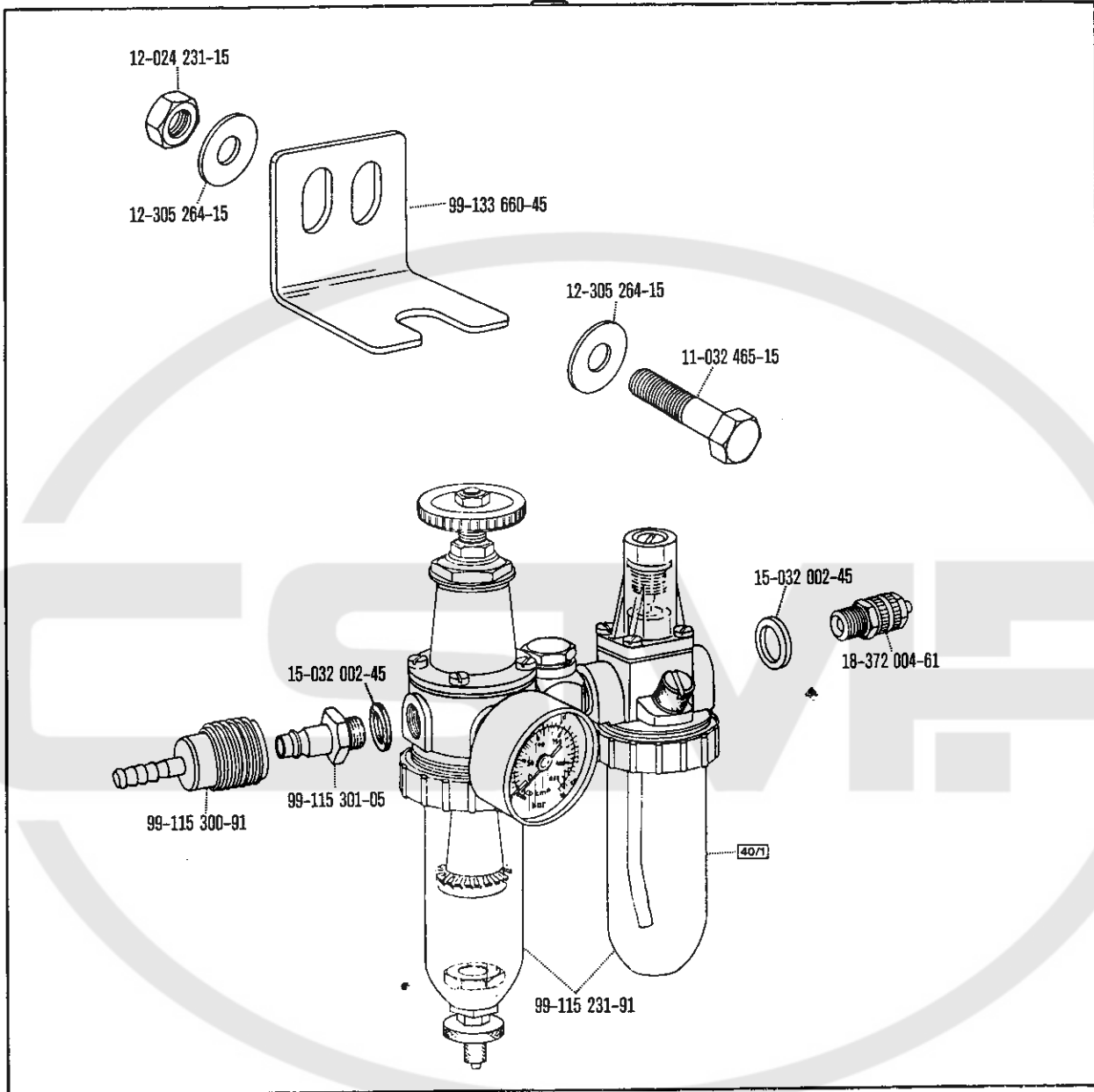

25 134-8.005-0 (99)

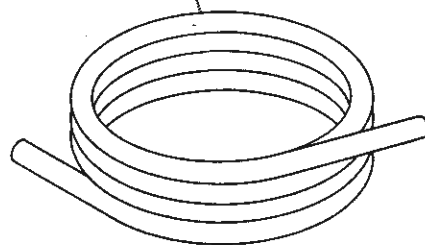

91-082 231-90

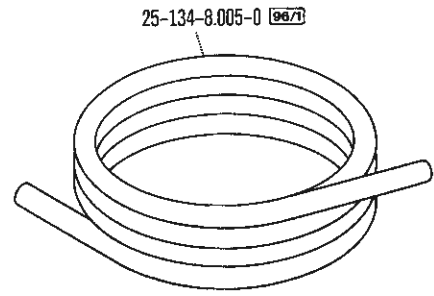
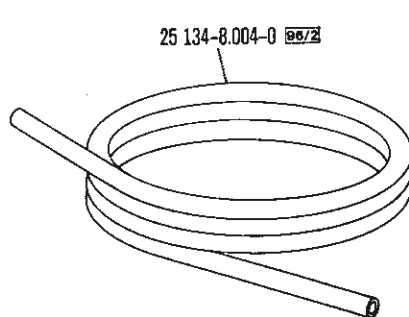
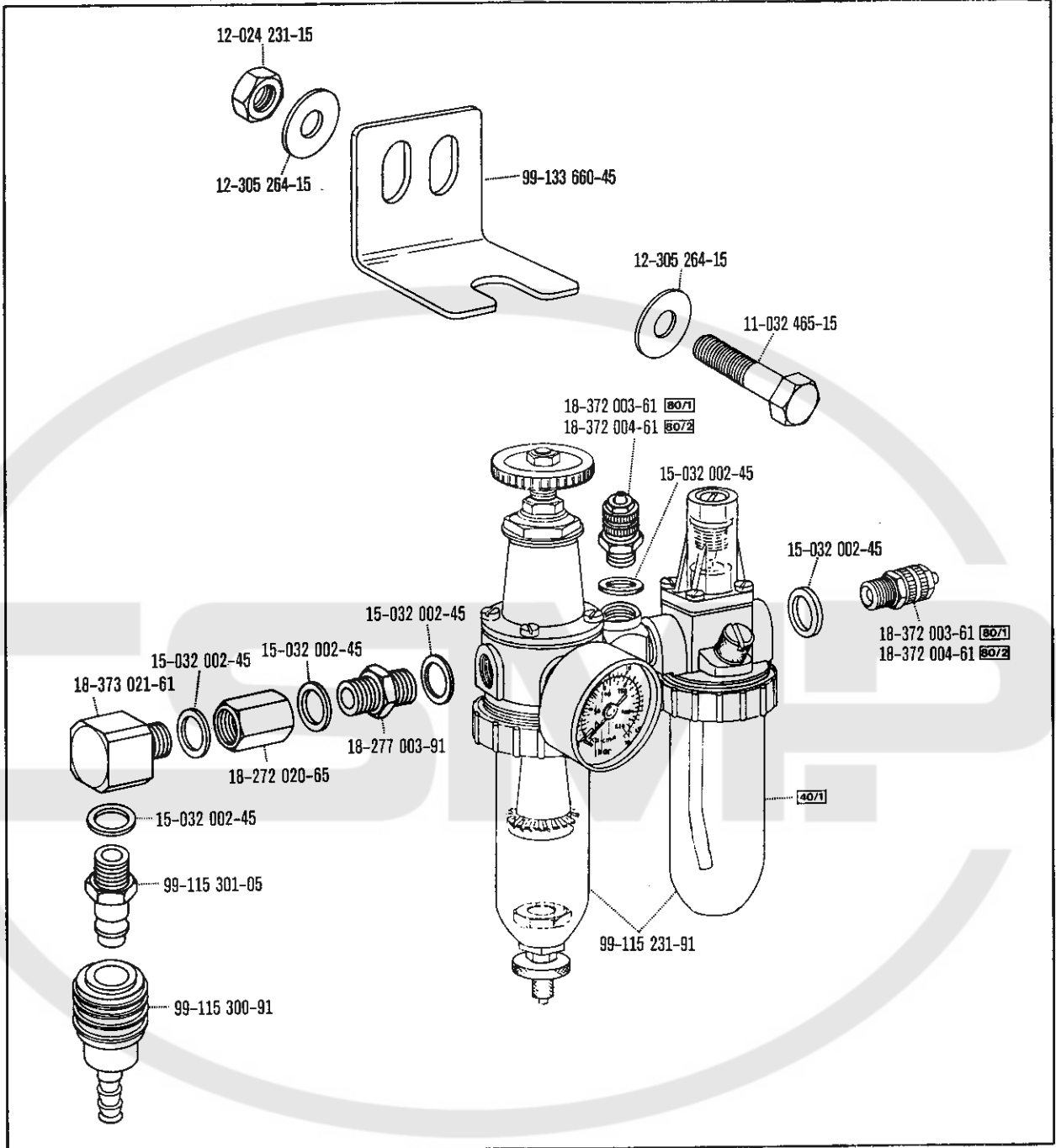

91-033 073-90

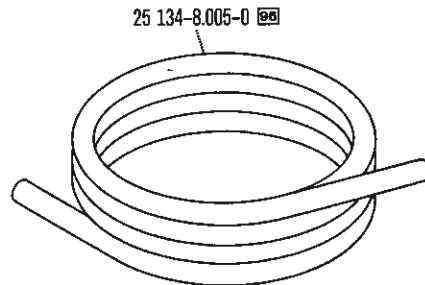
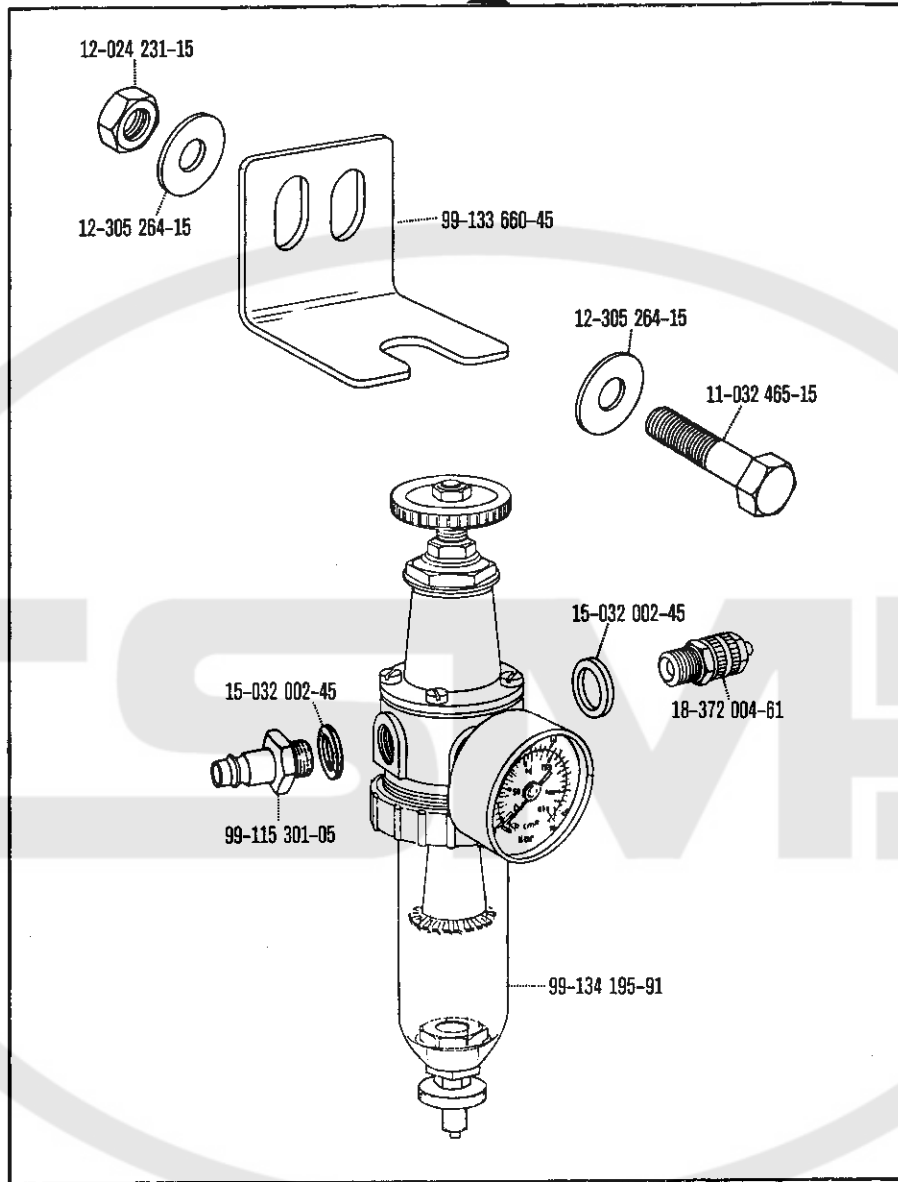

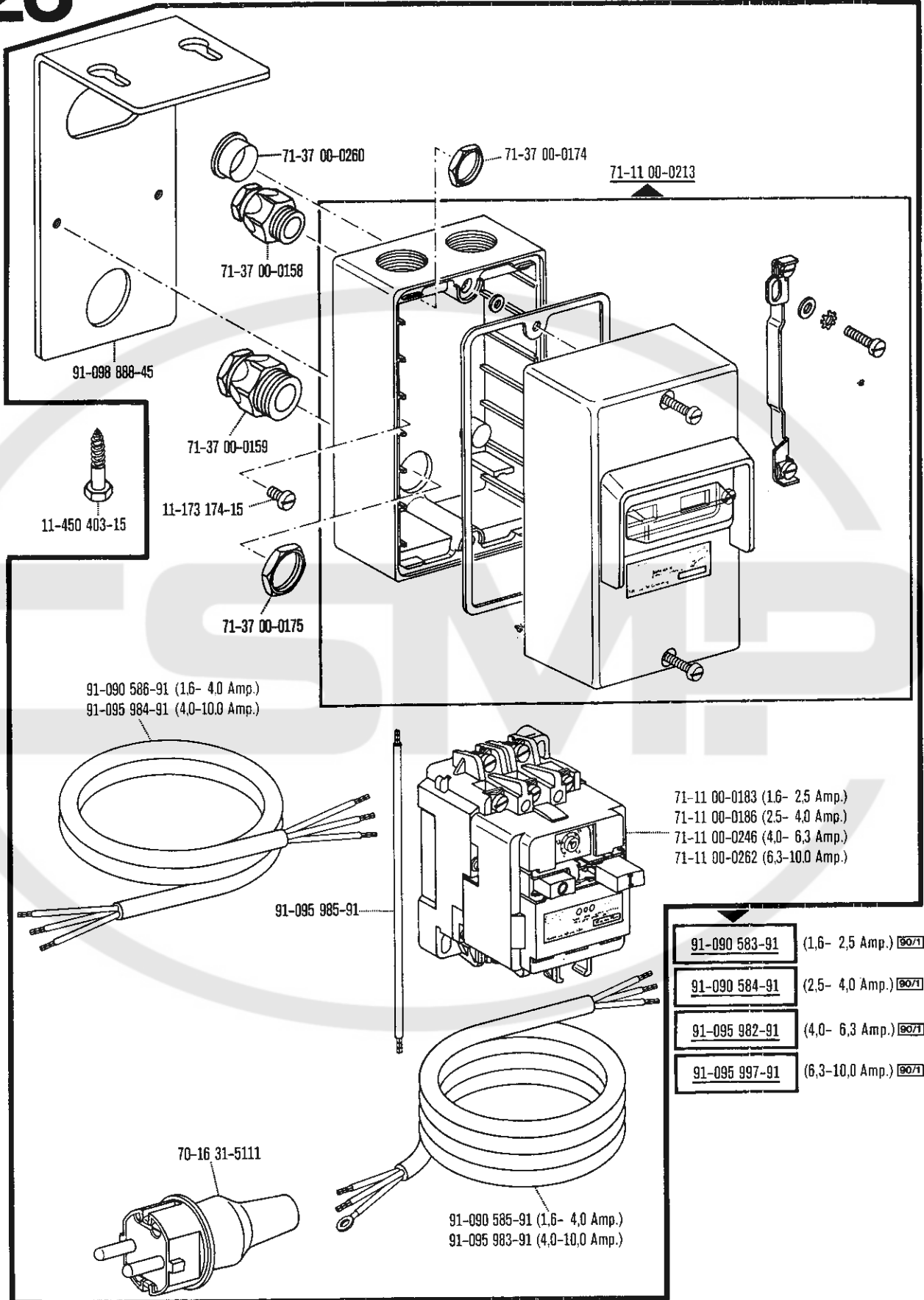

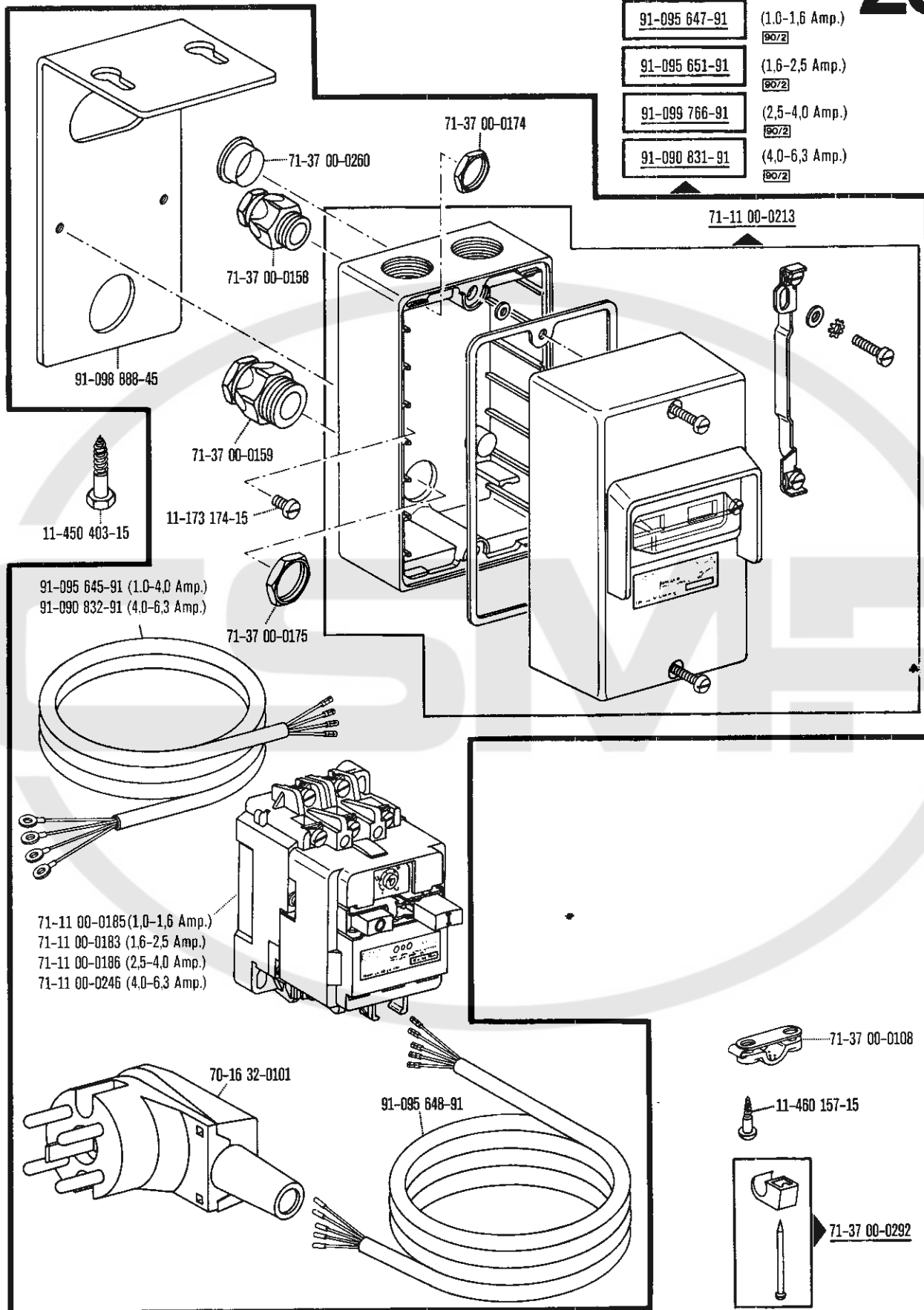

- 91-095 647-91 (1,0-1,6 Amp.)
90/2
- 91-095 651-91 (1,6-2,5 Amp.)
90/2
- 91-099 766-91 (2,5-4,0 Amp.)
90/2
- 91-090 831-91 (4,0-6,3 Amp.)
90/2

- 91-095 645-91 (1,0-4,0 Amp.)
- 91-090 832-91 (4,0-6,3 Amp.)

- 71-11 00-0185 (1,0-1,6 Amp.)
- 71-11 00-0183 (1,6-2,5 Amp.)
- 71-11 00-0186 (2,5-4,0 Amp.)
- 71-11 00-0246 (4,0-6,3 Amp.)

91-096 178-91 ^{90/1}

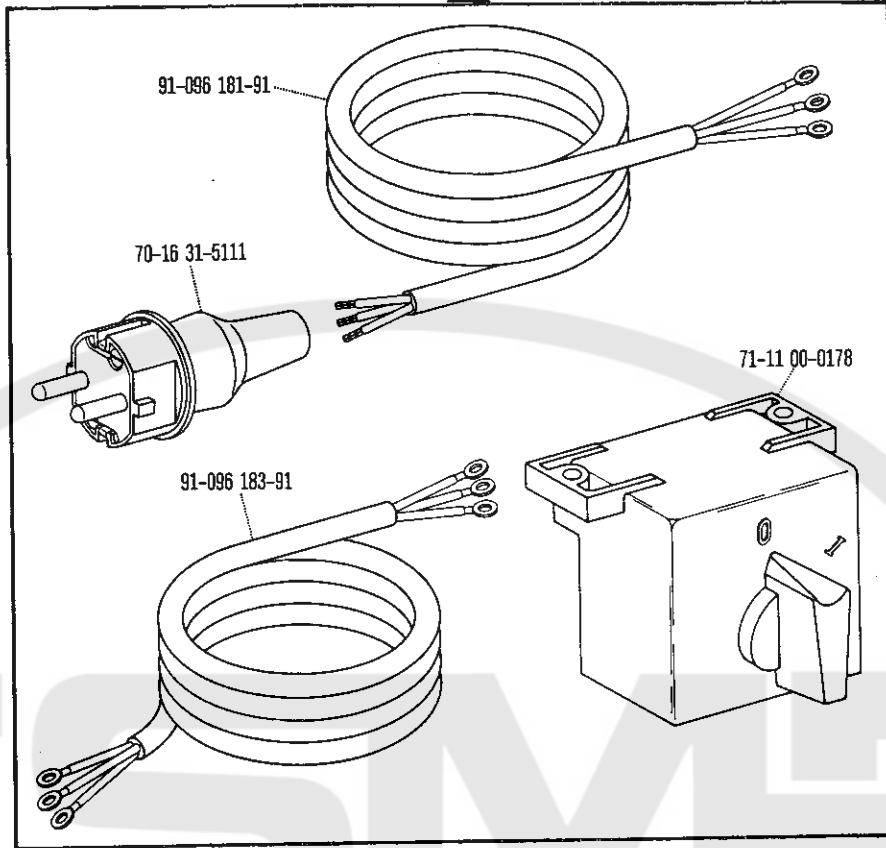

91-095 103-91 ^{90/2}

71-37 00-0108



11-460 157-15



71-37 00-0292

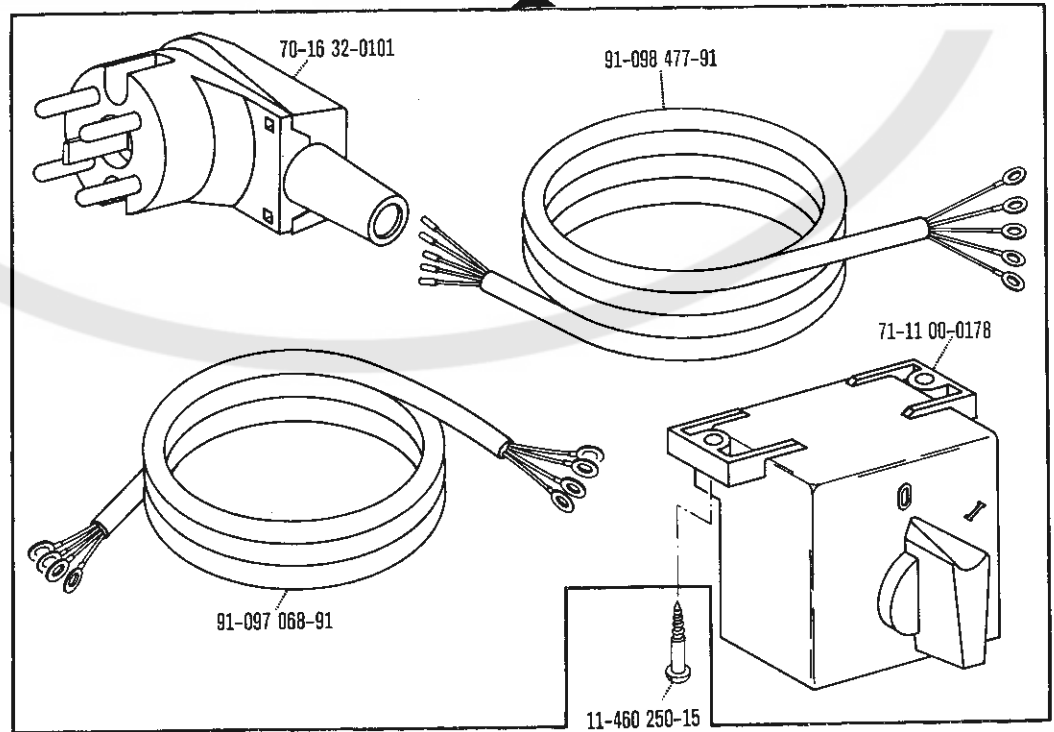
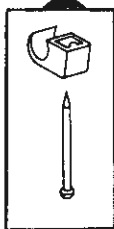

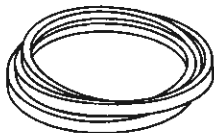







Keilriemen und Keilriemenscheiben
V-belt and V-belt pulley
Courroies et poulies trapézoïdales
Correa trapezoidal y poleas



Nähgeschwindigkeit max. Stiche/min. Maximum sewing speed in s.p.m. Nombre de points max./mn Número máx. de puntadas por minuto	Motordrehzahl U/min. Motor speed in r.p.m. Régime moteur en tours/mn Régimen del motor en r.p.m.	Frequenz Frequency Fréquence Frecuencia	Handrad-Durchmesser ¹⁾ in mm Balance wheel diameter ¹⁾ in mm Diamètre du volant ¹⁾ en mm Diámetro del volante ¹⁾ en mm	Keilriemenscheiben-Durchmesser ¹⁾ in mm V-belt pulley diameter ¹⁾ in mm Diamètre de la poulie à gorge ¹⁾ en mm Diámetro de la polea para correa en "V" ¹⁾ en mm	Teilenummer der Keilriemenscheibe Part number of V-belt pulley Numéro de pièce des poulies à gorge en V № de las piezas de poleas para correas en "V"	Maße des Keilriemens Dimensions of V-belt Dimensions de la courroie trapézoïdale Medidas de la correa trapezoidal	Teilenummer des Keilriemens Part number of V-belt Référence de la courroie trapézoïdale № de las piezas de la correa trapezoidal
4500	2800	50 Hz (c/s)	65	106	16-437 100-05	10 x 1120	16-414 139-55
4500	3400	60 Hz (c/s)	65	85	16-437 060-05	10 x 1120	16-414 139-55
4200	2800	50 Hz (c/s)	65	100	16-437 090-05	10 x 1120	16-414 139-55
4200	3400	60 Hz (c/s)	65	80	16-437 050-05	10 x 1120	16-414 139-55
3000	2800	50 Hz (c/s)	65	71	16-437 030-05	10 x 1120	16-414 139-55
3000	1700	60 Hz (c/s)	65	118	16-437 120-05	10 x 1180	16-414 140-55

Bestellnummer für Behälter mit:
Ordering number for can containing:
Numéro de commande pour récipients avec:
Número de pedido para recipientes con:

	Liter Litre Litro	Kg	Shell Tellus 123	Molikote Longterm 00	Shell-Alvania 3	Shell-Retimax G
	0,09		91-129 138-91			
	0,25		91-129 916-91			
	1		91-129 917-91			
	5		91-129 919-91			
	10		91-129 920-91			
	20		91-129 921-91			
	30		91-129 922-91			
	50		91-129 923-91			
		1		280-1-120 199	280-1-120 247	
		0,5				280-1-120 242

No.	Seite Page Pages Página	No.	Seite Page Pages Página	No.	Seite Page Pages Página	No.	Seite Page Pages Página
08-800 019-03	34	11-108 861-25	41, 44	11-186 976-15	53, 56	11-320 224-15	50, 59
08-800 019-04	34	11-108 870-25	64	11-210 038-15	53, 56	11-330 085-15	24, 36
08-800 019-05	34	11-130 176-15	14, 36	11-210 081-15	20	11-330 166-15	13, 14, 36, 41, 44
11-032 465-15	67, 68, 69	11-130 191-15	51, 58, 61	11-210 084-15	29	11-330 175-15	27
11-039 291-15	48	11-130 203-15	57, 59, 65	11-210 165-15	46	11-330 952-15	14, 23, 26, 28, 29, 40 43
11-039 354-15	53	11-130 224-15	24, 28, 29, 37, 49	11-210 168-15	15, 16, 20	11-330 955-15	23, 26, 30, 31, 36, 37 21
11-084 357-15	34	11-130 284-15	50, 59	11-210 169-15	17, 18, 19	11-335 166-15	21
11-108 021-15	47	11-130 287-15	50, 57	11-210 210-15	13	11-335 902-15	16, 17, 30
11-108 084-15	47	11-130 293-15	55	11-210 222-15	14	11-341 088-15	47
11-108 087-15	47	11-130 323-15	65	11-210 265-15	16	11-341 169-15	24, 37
11-108 093-15	29	11-130 377-15	50, 57, 59	11-210 279-15	39	11-341 902-15	16, 17, 23, 27, 29, 30, 31, 33, 39 40, 43
11-108 099-15	53, 56	11-132 316-15	26	11-225 172-15	13	11-345 091-15	40, 43
11-108 111-15	14, 37	11-132 538-15	27	11-225 283-15	57, 59	11-345 907-15	20
11-108 117-15	41, 53, 56	11-172 182-35	22	11-225 292-15	20, 50, 57, 59	11-450 403-15	70, 71
11-108 171-15	20, 22, 27, 39, 45, 62, 66	11-173 090-15	25	11-225 313-15	19	11-450 510-15	54
11-108 174-15	22, 29, 40, 41, 43, 44, 51, 58, 61, 65	11-173 096-15	21	11-250 084-25	16	11-460 109-15	53, 56
11-108 174-25	14, 36	11-173 171-55	53, 56	11-250 222-15	20	11-460 118-15	34
11-108 177-15	39, 40, 43, 65	11-173 174-15	70, 71	11-305 224-15	14	11-460 157-15	51, 55, 71, 72
11-108 180-15	33	11-173 225-15	39	11-305 230-15	40, 43	11-460 250-15	72
11-108 222-15	13, 15, 16, 30, 34, 40, 41, 43, 44, 46, 47	11-174 086-15	36	11-305 239-15	41, 44	11-460 304-15	49
11-108 225-15	15, 22, 23, 25, 26, 29, 30, 31, 32, 41, 44, 46, 53	11-174 170-15	14, 20, 36	11-305 248-15	25	11-460 406-15	51, 58, 61
11-108 228-15	54	11-174 173-15	13, 24	11-305 305-15	33	12-005 154-15	45, 62, 65, 66
11-108 234-15	13, 18, 19, 41	11-174 176-15	18, 19, 27	11-314 169-15	15	12-005 171-15	57, 59
11-108 237-15	24, 41	11-174 217-15	39	11-314 220-15	13, 26, 27, 36	12-005 175-15	40, 43
11-108 246-15	13, 41, 44	11-174 232-15	34	11-314 277-15	28, 29	12-005 195-15	14, 18, 19, 31, 33, 36, 38
11-108 258-15	34	11-174 293-15	41, 44	11-314 280-15	13, 14, 27, 28, 29	12-005 215-15	50, 59
11-108 285-15	22, 49	11-174 353-15	57, 59	11-314 946-15	15	12-024 121-15	47
11-108 288-15	55	11-174 359-15	33	11-314 964-15	26	12-024 151-15	21, 33, 41, 44
11-108 294-15	31	11-174 914-05	41, 44	11-317 083-15	21	12-024 171-15	23, 25, 37, 40, 41, 43, 44
		11-178 091-15	21	11-317 167-15	14, 36	12-024 172-15	40, 43
		11-178 166-15	20	11-317 908-15	39		
		11-178 292-15	21	11-317 949-15	41, 44		
		11-182 901-15	21	11-317 950-15	15, 26		

No.	Seite Page Pages Página	No.	Seite Page Pages Página	No.	Seite Page Pages Página	No.	Seite Page Pages Página
12-024 191-15	35, 41, 44, 55	12-640 170-55	21, 41, 44	14-012 555-01	26	14-680 070-15	16
12-024 223-15	41	12-640 200-55	24, 37	14-012 595-01	26	15-032 001-45	50, 51, 58, 59, 61
12-024 231-15	67, 68, 69	12-640 220-55	29	14-014 590-01	17	15-032 002-45	51, 67, 68, 69
12-085 170-15	41, 44	12-660 270-45	34	14-014 591-91	17	15-110 002-05	22
12-160 210-15	53	12-660 350-45	26	14-015 624-91	30	15-120 004-05	22
12-177 100-05	48	12-660 390-45	26, 27	14-016 080-01	26, 27	15-120 038-05	22
12-177 106-05	55	12-710 230-12	50, 59	14-016 130-01	17	15-120 112-05	27
12-305 084-15	41	13-030 313-05	14, 36	14-016 150-01	16	15-120 253-05	17, 39
12-305 114-15	33, 57, 59	13-030 341-05	35	14-016 151-91	16, 30	15-120 536-05	39
12-305 144-15	26, 37, 41, 44, 49	13-033 193-05	20	14-016 153-01	16, 30	15-120 702-05	27, 39
12-305 174-15	18, 26, 50, 57	13-033 220-05	41, 44	14-017 100-01	39	15-128 010-75	27
12-305 224-15	53	13-033 280-05	41, 44	14-017 620-01	30	15-128 060-75	27
12-305 264-15	67, 68, 69	13-052 049-75	13, 37	14-018 570-01	14, 36	15-130 074-05	15, 22
12-335 191-15	48, 51, 58, 61	13-052 067-75	40, 43	14-018 620-01	30	15-130 082-05	22
12-341 150-15	40, 43	13-052 151-15	27	14-018 643-01	16	15-256 055-01	17
12-500 151-45	51, 58, 61	13-052 193-15	19	14-018 644-91	16	16-049 020-11	40, 43
12-501 190-45	55	13-052 247-15	50, 57, 59	14-210 440-01	17, 39	16-049 021-11	40, 43
12-510 110-45	41, 44, 65	13-052 256-15	49	14-215 013-13	26, 36	16-049 040-11	49
12-610 150-45	25	13-060 400-05	27	14-215 019-13	18, 38	16-414 139-55	73
12-610 170-45	14, 36	13-060 902-05	18, 38	14-215 022-13	13, 23	16-414 140-55	73
12-610 190-45	25, 26, 32, 36	13-065 259-05	13	14-215 049-13	28, 29	16-437 030-05	73
12-610 200-45	26	13-068 961-05	21	14-215 073-13	18, 38	16-437 050-05	73
12-610 210-45	27, 37	13-070 981-05	34, 50, 59	14-215 121-13	29	16-437 060-05	73
12-610 230-45	15, 21, 26, 41, 44	13-115 244-05	40, 43	14-215 274-43	29	16-437 090-05	73
12-610 250-45	17	13-115 361-05	15	14-218 190-01	27	16-437 100-05	73
12-610 280-45	29, 30	13-130 364-05	15	14-218 220-01	65	16-437 120-05	73
12-610 310-45	30	13-135 036-05	15	14-602 901-01	16	16-919 051-05	20
12-618 080-45	20	13-240 201-05	55	14-650 214-05	14, 27	16-919 071-15	20
12-624 260-45	17	13-250 097-25	13	14-650 243-05	14	18-272 020-65	68
12-624 310-45	25	14-010 173-01	30, 31	14-650 275-05	27	18-277 003-91	68
12-640 090-55	47	14-010 665-01	23	14-680 020-15	17	18-279 010-91	51, 58, 61
12-640 130-55	16, 41, 44, 47	14-011 080-01	39	14-680 030-15	30	18-372 003-61	68
12-640 150-55	23	14-012 545-01	26	14-680 060-15	16, 30	18-372 004-61	67, 68, 69

No.	Seite Page Pages Página	No.	Seite Page Pages Página	No.	Seite Page Pages Página	No.	Seite Page Pages Página
18-373 021-61	68	71-14 00-0009	45, 66	71-37 00-0223	65	91-002 065-05	15
18-378 001-61	50, 51, 57, 58, 59, 60, 61	71-14 00-0010	45, 66	71-37 00-0226	65	91-002 134-05	26
18-378 002-61	51, 58, 61	71-14 00-0011	45, 66	71-37 00-0260	70, 71	91-002 262-25	15
40-754 701-00	35	71-14 00-0014	45, 66	71-37 00-0292	64, 71, 72	91-004 006-05	15, 35
70-15 21-5001	54	71-16 00-0065	49, 52	71-37 00-0309	56	91-004 181-05	29
70-15 31-0001	54	71-16 00-0112	49, 52, 62	71-37 00-0315	53, 56	91-006 584-05	15
70-16 31-5111	70, 72	71-16 00-0118	42, 49, 52 60, 63	71-37 00-0317	53, 56	91-006 814-05	15
70-16 32-0101	71, 72	71-16 00-0137	41	71-44 00-0026	54	91-006 818-05	15
70-37 15-0002	54	71-16 00-0140	53, 56	71-54 00-0066	54	91-009 026-05	26
70-37 15-0003	53, 56	71-16 00-0141	53, 56	71-59 00-0089	48, 49	91-009 148-05	13
70-37 45-0002	53, 56	71-16 00-0142	53, 56	71-59 00-0098	48, 49	91-010 538-05	20
70-37 70-0006	52, 60	71-16 00-0143	53, 56	71-59 00-0237	49, 52	91-011 220-05	55
70-41 37-0023	54	71-16 00-0208	60	71-59 00-0242	48	91-017 331-12	24, 37
70-44 14-0151	54	71-17 00-0125	55	71-59 00-0259	42, 63	91-027 289-15	34
71-11 00-0133	65	71-17 00-0131	41, 44	71-59 00-0264	48	91-027 370-05	34
71-11 00-0178	72	71-17 00-0145	47	71-59 00-0265	48	91-027 371-12	34
71-11 00-0183	70, 71	71-19 00-0080	54	71-59 00-0268	42, 63	91-029 007-91	35
71-11 00-0185	71	71-21 00-0125	44, 47	71-59 00-0331	48	91-029 033-45	34
71-11 00-0186	70, 71	71-21 00-0136	41	71-59 00-0332	48	91-029 450-15	35
71-11 00-0213	70, 71	71-21 00-0185	65	71-59 00-0333	48	91-029 692-45	34
71-11 00-0232	49, 52	71-23 00-0118	41, 62, 65	71-59 00-0334	48	91-029 809-05	34
71-11 00-0246	70, 71	71-37 00-0108	71, 72	71-59 00-0335	48	91-029 811-05	34
71-11 00-0262	70	71-37 00-0119	55	71-59 00-0336	48	91-029 946-91	35
71-12 00-0025	41, 53, 56	71-37 00-0132	44, 47, 65	71-59 00-0351	45, 66	91-030 737-05	17, 39
71-12 00-0559	42, 63	71-37 00-0133	41, 53, 56	71-59 00-0352	45, 66	91-031 888-15	31
71-12 00-0566	64	71-37 00-0140	55	71-59 00-0368	48	91-032 087-45	34
71-12 00-0575	49, 52	71-37 00-0158	54, 55, 70, 71	71-63 00-0056	54	91-032 203-15	31
71-12 00-0576	42, 49, 52, 63	71-37 00-0159	70, 71	91-000 177-15	26	91-032 211-15	31
71-12 00-0577	48	71-37 00-0167	53, 56	91-000 249-15	26	91-032 477-91	53
71-12 00-0598	64	71-37 00-0173	53, 56	91-000 250-15	26	91-032 478-25	53
71-13 00-0327	64	71-37 00-0174	54, 70, 71	91-000 390-15	26	91-032 479-05	53
71-14 00-0006	62	71-37 00-0175	70, 71	91-000 408-05	26	91-032 800-91	35
		71-37 00-0208	65	91-000 790-15	26	91-032 801-91	35

No.	Seite Page Pages Página	No.	Seite Page Pages Página	No.	Seite Page Pages Página	No.	Seite Page Pages Página
91-032 802-45	35	91-084 137-90	46	91-096 178-91	72	91-101 775-05	35
91-032 803-45	35	91-090 304-45	41	91-096 181-91	72	91-105 447-15	15
91-032 804-45	35	91-090 305-45	41	91-096 183-91	72	91-107 204-15	28
91-033 073-90	69	91-090 316-91	41	91-096 334-15	40, 43	91-107 711-15	45, 62, 65, 66
91-056 192-25	15, 35	91-090 583-91	70	91-096 560-91	41	91-107 723-05	45, 62, 65, 66
91-056 193-25	15, 35	91-090 584-91	70	91-096 611-45	64	91-107 888-45	53, 56
91-056 197-91	15	91-090 585-91	70	91-096 612-45	64	91-107 889-45	53, 56
91-056 198-11	15	91-090 586-91	70	91-096 620-91	54	91-107 890-05	53, 56
91-056 578-91	35	91-090 700-90	64	91-096 621-91	55	91-107 891-15	53, 56
91-056 579-11	35	91-090 831-91	71	91-096 622-91	54	91-107 892-15	53, 56
91-061 337-05	13	91-090 832-91	71	91-096 623-91	53, 56	91-118 098-25	16
91-064 689-12	23	91-091 248-05	47	91-096 624-01	55	91-118 099-91	16
91-068 027-05	20	91-091 330-01	65	91-096 625-01	55	91-118 227-05	47
91-069 042-01	19	91-091 331-91	65	91-096 747-91	56	91-118 229-05	47
91-069 079-92	15	91-091 332-91	65	91-097 068-91	72	91-118 230-91	47
91-069 165-15	40, 43	91-091 333-91	65	91-097 074-47	35	91-118 231-11	47
91-069 172-15	34	91-095 103-91	72	91-097 077-15	22	91-118 234-11	47
91-069 224-05	27	91-095 645-91	71	91-097 149-15	51	91-118 240-15	47
91-069 226-05	27	91-095 647-91	71	91-097 902-45	54	91-118 241-05	47
91-069 259-05	27	91-095 648-91	71	91-098 477-91	72	91-118 242-15	47
91-069 287-05	28, 29	91-095 651-91	71	91-098 888-45	70, 71	91-118 243-11	47
91-069 335-92	34	91-095 675-91	54	91-099 766-91	71	91-118 246-11	47
91-069 365-12	25, 30, 31, 57, 59	91-095 729-45	64	91-099 811-05	53, 56	91-118 249-05	47
91-069 366-05	25	91-095 829-91	52, 60	91-099 904-45	41, 44	91-118 416-15	41
91-069 416-05	25	91-095 836-45	47	91-100 270-15	20, 53, 56	91-118 612-05	40, 43
91-069 553-05	30	91-095 837-91	60	91-100 275-15	40, 43	91-118 681-05	16
91-069 585-25	35	91-095 846-91	47	91-100 281-25	16	91-118 682-05	16
91-069 768-05	24, 30, 37	91-095 850-91	44	91-100 283-15	20	91-118 683-05	16
91-082 231-90	68	91-095 982-91	70	91-100 284-15	20	91-118 685-05	16
91-084 101-91	46	91-095 983-91	70	91-100 289-15	31	91-118 893-92	40, 43
91-084 115-05	46	91-095 984-91	70	91-100 296-25	29	91-118 931-05	16
91-084 117-15	46	91-095 985-91	70	91-100 331-15	14	91-118 934-91	16
91-084 135-90	46	91-095 997-91	70	91-100 339-15	40, 43	91-118 935-05	16

No.	Seite Page Pages Página	No.	Seite Page Pages Página	No.	Seite Page Pages Página	No.	Seite Page Pages Página
91-118 937-01	16	91-167 571-01	14, 36	91-167 710-91	15	91-168 033-05	13
91-118 939-21	16	91-167 589-05	18, 38	91-167 719-01	37	91-168 038-05	13
91-118 940-05	16	91-167 603-05	14	91-167 720-91	37	91-168 039-05	13
91-118 953-15	49	91-167 604-15	14, 37	91-167 721-01	37	91-168 040-05	13
91-118 955-15	49	91-167 606-91	14	91-167 722-91	37	91-168 041-05	13
91-118 956-15	49	91-167 607-01	18, 38	91-167 723-05	37	91-168 042-04	13
91-129 138-91	74	91-167 608-05	18, 38	91-167 724-05	26	91-168 045-05	14, 36
91-129 139-01	34	91-167 609-05	18, 38	91-167 731-45	57, 59	91-168 046-15	13
91-129 443-12	41, 44	91-167 610-05	18, 38	91-167 749-15	50, 57, 59	91-168 047-14	13
91-129 916-91	74	91-167 611-92	18	91-167 750-05	50, 59	91-168 054-92	16
91-129 917-91	74	91-167 612-05	18, 38	91-167 754-91	50	91-168 055-91	16
91-129 919-91	74	91-167 614-05	18	91-167 760-91	57	91-168 057-15	16
91-129 920-91	74	91-167 618-91	18	91-167 768-91	59	91-168 058-11	28, 29
91-129 921-91	74	91-167 621-05	20	91-167 779-12	50, 59	91-168 059-05	15
91-129 922-91	74	91-167 625-91	18	91-167 782-15	50, 57	91-168 061-15	13
91-129 923-91	74	91-167 631-91	20	91-167 799-91	18	91-168 063-25	15
91-167 510-05	39	91-167 636-05	41, 44, 47	91-167 800-91	31	91-168 065-05	22
91-167 541-12	53	91-167 646-05	65	91-168 001-45	22	91-168 066-92	13, 37
91-167 543-15	20	91-167 647-45	65	91-168 009-05	27	91-168 069-05	18
91-167 544-05	20	91-167 648-15	65	91-168 010-91	13	91-168 071-05	19
91-167 545-15	20	91-167 649-05	40, 43	91-168 013-05	13	91-168 072-05	19
91-167 549-11	40, 43	91-167 652-92	50, 57, 59	91-168 017-05	13	91-168 073-05	18
91-167 550-15	40, 43	91-167 653-05	57, 59	91-168 018-05	13	91-168 076-04	19
91-167 556-11	41, 44	91-167 654-15	57, 59	91-168 019-91	13	91-168 077-04	19
91-167 559-05	41	91-167 655-11	57, 59	91-168 020-01	13	91-168 078-05	19
91-167 560-05	41, 44	91-167 659-92	50, 59	91-168 023-03	13	91-168 081-05	18, 19
91-167 561-05	20	91-167 689-92	14	91-168 025-05	13	91-168 083-05	19
91-167 564-91	23	91-167 690-15	15	91-168 026-05	27	91-168 084-91	19
91-167 565-91	23	91-167 692-91	37	91-168 027-92	13	91-168 088-15	19, 39
91-167 566-91	23	91-167 694-04	37	91-168 028-04	13	91-168 089-11	31
91-167 567-05	13	91-167 695-04	37	91-168 029-92	13	91-168 090-91	17
91-167 569-01	13	91-167 696-91	37	91-168 030-05	13	91-168 092-05	28, 29
91-167 570-01	13	91-167 702-91	36	91-168 032-01	13	91-168 093-05	17, 39

No.	Seite Page Pages Página	No.	Seite Page Pages Página	No.	Seite Page Pages Página	No.	Seite Page Pages Página
91-168 095-05	17	91-168 165-90	39	91-168 226-91	27	91-168 286-92	27
91-168 099-04	17	91-168 166-91	15	91-168 227-11	27	91-168 290-91	27
91-168 100-93	17	91-168 167-05	15	91-168 230-45	34	91-168 290-92	27
91-168 105-05	13	91-168 168-92	15	91-168 231-45	34	91-168 292-15	35
91-168 106-05	18	91-168 169-05	40, 43	91-168 232-05	27	91-168 293-12	26
91-168 108-05	22, 39	91-168 170-91	15	91-168 233-05	27	91-168 294-01	22
91-168 111-91	22	91-168 171-92	15	91-168 236-15	20	91-168 295-91	26
91-168 112-05	22	91-168 172-05	15	91-168 237-01	38	91-168 296-05	26
91-168 113-05	22	91-168 173-05	15	91-168 243-05	30	91-168 297-05	26
91-168 114-05	22	91-168 174-05	15	91-168 244-04	16	91-168 299-05	26
91-168 115-05	22	91-168 175-05	22	91-168 245-05	16	91-168 300-12	26
91-168 117-05	22	91-168 176-05	22	91-168 250-45	27	91-168 304-01	22
91-168 121-05	20	91-168 177-05	22	91-168 254-05	30	91-168 308-05	21
91-168 122-05	20	91-168 178-05	26	91-168 255-91	30	91-168 310-91	29
91-168 123-05	20	91-168 179-91	22	91-168 256-05	33	91-168 314-05	29
91-168 124-45	20	91-168 180-91	22	91-168 257-91	30	91-168 315-12	29
91-168 125-05	20	91-168 183-05	22	91-168 258-92	30	91-168 316-05	29
91-168 127-11	20	91-168 185-15	22	91-168 259-05	26	91-168 318-05	29
91-168 130-05	21	91-168 186-15	22	91-168 262-05	26	91-168 319-12	28, 29
91-168 131-01	20	91-168 190-91	15	91-168 263-92	26	91-168 320-91	29
91-168 134-05	20	91-168 191-15	15	91-168 266-92	26	91-168 321-05	28, 29
91-168 136-01	20	91-168 192-15	15	91-168 269-05	26	91-168 322-05	28, 29
91-168 139-92	20	91-168 193-05	15	91-168 270-92	27	91-168 323-12	28, 29
91-168 141-05	20	91-168 194-91	15	91-168 271-92	26	91-168 327-92	30, 31
91-168 145-15	20	91-168 201-12	25, 32	91-168 275-05	27	91-168 328-92	30, 31
91-168 146-11	20	91-168 202-15	30	91-168 276-05	26	91-168 329-05	30, 31
91-168 147-45	20	91-168 203-05	31	91-168 277-05	25, 32	91-168 331-05	33
91-168 148-05	20	91-168 204-15	32	91-168 279-90	26	91-168 334-05	30, 31
91-168 149-05	20	91-168 206-12	32	91-168 280-91	27	91-168 335-05	30, 31
91-168 150-05	20	91-168 214-15	21	91-168 281-05	27	91-168 336-05	30, 31
91-168 153-05	20	91-168 218-91	21	91-168 282-91	27	91-168 337-92	30
91-168 154-05	20	91-168 222-11	26	91-168 283-05	27	91-168 340-04	30
91-168 161-05	14	91-168 223-01	21	91-168 284-05	27	91-168 341-05	30

No.	Seite Page Pages Página	No.	Seite Page Pages Página	No.	Seite Page Pages Página	No.	Seite Page Pages Página
91-168 344-05	29	91-168 412-15	40, 43	91-168 507-05	28	91-168 561-91	21
91-168 347-05	29	91-168 413-15	40, 43	91-168 508-92	31	91-168 563-05	21
91-168 348-05	29	91-168 415-15	41, 44	91-168 509-91	29	91-168 565-15	21
91-168 350-12	29	91-168 425-91	22	91-168 511-04	31	91-168 569-01	30
91-168 352-15	29	91-168 426-91	22	91-168 512-91	28	91-168 570-91	17
91-168 353-91	29	91-168 427-45	22	91-168 513-15	28	91-168 571-05	17
91-168 355-11	41, 44	91-168 428-05	22	91-168 514-12	28	91-168 572-93	17
91-168 356-05	27	91-168 429-05	22	91-168 515-05	28	91-168 574-91	16
91-168 357-05	27	91-168 434-01	26	91-168 517-91	34	91-168 575-91	16
91-168 358-05	27	91-168 438-05	13	91-168 518-41	34	91-168 577-91	16
91-168 365-01	27	91-168 439-05	13	91-168 521-91	32	91-168 578-91	16
91-168 368-05	27	91-168 440-12	49	91-168 522-91	21	91-168 579-91	30
91-168 369-05	27	91-168 442-15	26	91-168 523-15	32	91-168 580-05	30
91-168 370-91	33	91-168 443-05	15	91-168 525-12	32	91-168 583-05	47
91-168 371-45	33	91-168 444-05	13	91-168 526-05	32	91-168 588-91	26
91-168 372-05	33	91-168 468-05	26	91-168 527-91	32	91-168 589-15	26
91-168 373-12	33	91-168 469-92	39	91-168 528-15	32	91-168 590-91	26
91-168 375-91	34	91-168 472-91	27	91-168 529-15	32	91-168 591-05	26
91-168 376-15	34	91-168 473-05	27	91-168 530-12	32	91-168 592-05	27
91-168 377-05	33	91-168 474-91	27	91-168 531-01	21	91-168 593-05	29
91-168 379-35	29	91-168 480-15	16	91-168 533-91	31	91-168 595-05	29
91-168 380-91	29	91-168 482-91	27	91-168 534-91	24	91-168 596-92	27
91-168 381-15	33	91-168 488-91	24	91-168 535-45	21	91-168 597-05	29
91-168 381-92	33	91-168 493-91	30	91-168 538-01	21	91-168 601-91	13
91-168 382-05	33	91-168 494-04	30	91-168 541-05	29	91-168 602-01	13
91-168 383-05	33	91-168 495-05	30	91-168 542-05	29	91-168 603-05	13
91-168 384-05	33	91-168 496-92	30	91-168 543-05	21	91-168 607-92	18, 19
91-168 386-05	13	91-168 497-11	40, 43	91-168 544-05	21	91-168 609-91	19
91-168 389-91	13	91-168 498-15	40, 43	91-168 546-01	21	91-168 618-05	26
91-168 408-91	40, 43	91-168 499-05	40, 43	91-168 550-11	21	91-168 623-05	26
91-168 409-11	40, 43	91-168 503-92	31	91-168 553-92	21	91-168 626-05	26
91-168 410-05	40, 43	91-168 505-91	28	91-168 555-21	21	91-168 627-45	26
91-168 411-05	40, 43	91-168 506-05	28	91-168 559-12	21	91-168 628-91	26

No.	Seite Page Pages Página	No.	Seite Page Pages Página	No.	Seite Page Pages Página	No.	Seite Page Pages Página
91-168 629-05	26	91-168 842-12	23	91-168 912-15	41, 44	91-168 974-05	40, 43
91-168 630-01	26	91-168 843-05	23	91-168 913-05	41, 44	91-168 975-15	40, 43
91-168 644-15	53	91-168 844-05	23	91-168 914-15	41, 44	91-168 976-15	40, 43
91-168 648-91	47	91-168 845-92	23	91-168 917-05	41, 44	91-168 979-05	38
91-168 720-45	22	91-168 854-91	16	91-168 918-05	41, 44	91-168 980-05	38
91-168 720-92	22	91-168 855-91	25	91-168 921-05	41	91-168 981-05	38
91-168 741-91	29	91-168 856-15	25	91-168 921-92	41	91-168 982-05	38
91-168 742-25	29	91-168 857-05	30	91-168 922-15	41, 44	91-168 983-05	38
91-168 746-91	19	91-168 858-12	25	91-168 923-05	41	91-168 984-05	38
91-168 771-05	33	91-168 858-15	25	91-168 924-45	22	91-168 985-05	38
91-168 806-45	13	91-168 859-91	25	91-168 927-15	41, 44	91-168 988-01	38
91-168 808-01	15	91-168 860-11	25	91-168 928-05	19	91-168 989-05	38
91-168 810-05	15	91-168 864-12	25	91-168 929-05	19	91-168 991-45	39
91-168 811-91	22	91-168 865-91	38	91-168 932-15	41	91-168 992-45	39
91-168 814-15	13	91-168 867-90	64	91-168 934-05	41, 44	91-168 993-15	39
91-168 820-91	14	91-168 869-15	47	91-168 934-92	41, 44	91-168 996-05	38
91-168 821-05	14, 36	91-168 870-45	46, 47	91-168 935-92	41	91-168 998-05	38
91-168 822-92	14, 36	91-168 880-04	38	91-168 938-91	41, 44	91-168 999-04	38
91-168 823-92	22	91-168 882-05	38	91-168 939-15	41, 44	91-169 029-05	15, 35
91-168 824-91	13	91-168 887-91	26	91-168 941-91	39	91-169 116-05	14, 36
91-168 825-91	24	91-168 888-91	26	91-168 945-05	41, 44	91-169 137-05	24, 37
91-168 826-92	24	91-168 893-05	39	91-168 946-92	39	91-169 166-05	14
91-168 827-04	24	91-168 896-91	39	91-168 947-01	39	91-169 356-05	27
91-168 828-12	24	91-168 897-05	39	91-168 948-05	17, 39	91-169 384-15	47
91-168 829-12	24, 37	91-168 898-01	38	91-168 949-91	19	91-169 523-05	23
91-168 830-15	23	91-168 901-92	40, 43	91-168 961-15	40, 43	91-169 556-05	36
91-168 831-14	23	91-168 902-92	40	91-168 962-11	40, 43	91-169 582-05	41, 44
91-168 832-14	23	91-168 904-05	41, 44	91-168 966-15	40, 43	91-169 974-05	27
91-168 833-05	30, 31	91-168 906-45	41, 44	91-168 967-05	39	91-170 441-91	14
91-168 835-14	24, 37	91-168 907-05	41, 44	91-168 968-91	39	91-170 442-15	14
91-168 836-45	24	91-168 909-15	41, 44	91-168 970-91	40, 43	91-170 443-12	24
91-168 840-91	23	91-168 910-05	41, 44	91-168 971-92	40, 43	91-170 783-91	53, 56
91-168 841-12	23	91-168 911-15	41, 44	91-168 972-05	39	91-171 042-45	16

No.	Seite Page Pages Página	No.	Seite Page Pages Página	No.	Seite Page Pages Página	No.	Seite Page Pages Página
91-171 049-05	16	91-171 406-15	25	91-700 249-15	40, 43	99-134 911-05	22
91-171 159-05	30, 31	91-171 407-15	25	91-700 335-15	24	280-1-120 199	74
91-171 205-05	30, 31	91-171 462-80	67	91-700 335-25	15	280-1-120 242	74
91-171 227-05	36	91-171 501-91	41	91-700 689-15	16, 30, 40, 43	280-1-120 247	74
91-171 229-05	36	91-171 535-15	50, 57, 59	91-700 739-15	29	25 134-8.004-0	51, 57, 58, 60, 61, 68
91-171 230-12	14, 36	91-171 627-45	53, 56	91-700 785-15	25, 28, 29, 30, 31, 57, 59	25 134-8.005-0	67, 68, 69
91-171 232-15	36	91-171 677-15	29,	91-700 868-15	14		
91-171 233-15	36	91-171 793-05	26	91-700 961-15	40, 43		
91-171 255-12	23	91-171 801-14	14, 24	91-701 179-15	13, 37		
91-171 268-04	23	91-171 804-05	14, 36	91-701 515-25	35		
91-171 269-15	23	91-171 808-05	14	97-30 118-345	34		
91-171 270-05	23	91-171 809-05	14, 36	99-069 707-01	24, 37		
91-171 272-04	23	91-171 835-91	44	99-069 713-01	23		
91-171 273-04	23	91-172 939-05	21	99-096 072-91	49, 52		
91-171 290-15	55	91-174 026-05	41, 44	99-115 184-01	13, 19		
91-171 294-15	55	91-174 027-15	41, 44	99-115 231-91	67, 68		
91-171 304-05	14, 36	91-174 034-05	40, 43	99-115 300-91	67, 68		
91-171 307-05	14, 36	91-174 037-12	37	99-115 301-05	67, 68, 69		
91-171 313-15	24	91-174 072-12	37	99-133 163-01	14, 36		
91-171 319-92	14	91-174 074-15	37	99-133 218-01	24, 37		
91-171 323-05	14, 36	91-174 081-05	36	99-133 221-01	14, 23, 24		
91-171 329-04	24	91-174 082-15	36	99-133 574-91	58		
91-171 330-12	24, 37	11-174 914-05	41	99-133 660-45	67, 68, 69		
91-171 340-91	14	91-175 514-91	51	99-133 752-01	51, 58, 61		
91-171 363-15	14	91-175 515-45	51, 58, 61	99-134 008-91	52, 60		
91-171 364-15	14, 36	91-175 532-12	36	99-134 089-05	46		
91-171 367-15	14	91-175 533-15	36	99-134 093-05	46		
91-171 368-05	14	91-175 544-91	36	99-134 195-91	69		
91-171 369-05	14, 36	91-175 546-91	36	99-134 369-91	51, 60, 61		
91-171 372-12	24	91-175 549-05	36	99-134 452-91	51, 58, 60, 61		
91-171 373-05	24, 36	91-176 031-91	58	99-134 623-91	57, 59		
91-171 374-92	14	91-176 051-91	61	99-134 900-91	50, 59		
91-171 405-15	25	91-700 226-15	20				