

114

Teileliste

Parts list

Lista de piezas

零件表

Diese Teileliste hat für Maschinen ab nachfolgender
Seriennummer Gültigkeit:

This parts list applies to machines from the following
serial numbers onwards:

Esta lista de piezas tiene validez para máquinas a partir del
número de serie siguiente:

本零件表对从下列系列号起的机器有效:

6001000 →

Alle Informationen und Abbildungen waren zum Zeitpunkt der Druckgebung auf dem neusten Stand.

Technische Änderungen vorbehalten!

Der Nachdruck, die Vervielfältigung sowie die Übersetzung - auch auszugsweise - aus PFAFF-Teilelisten ist nur mit unserer vorherigen Zustimmung und mit der Quellenangabe gestattet.

At the time of printing, all information and illustrations contained in this document were up to date.

Subject to alteration!

The reprinting, copying or translation of PFAFF Parts lists whether in whole or in part, is only permitted with our previous permission and with written reference to the source.

Todas las informaciones e ilustraciones de este manual estaban al día en el momento de entregarse para su impresión.

¡ Salvo modificaciones técnicas!

La reimpresión, reproducción y traducción - aunque sólo sea parcial - de las listas de piezas PFAFF sólo está permitida con nuestro permiso previo e indicando la fuente.

所有信息和图片在付印时都是最新的。

保留技术更改的权力!

全部或部分翻印、复制以及翻译PFAFF-零件表
必须事先经由我们同意并且注明来源。

PFAFF Industrie Maschinen AG

Postfach 3020

D-67653 Kaiserslautern

Königstr. 154

D-67655 Kaiserslautern

		Seite Page Página 页号
0	Wichtiger Hinweis Important note Observación importante 重要提示	0 - 1
1	Vorwort Foreword Notas preliminares 前言	1 - 1
2	Erläuterungen der Schlüsselzeichen Explanation of key markings Explicaciones de los signos clave 标记说明	2 - 1
3.01	Gehäuseteile Housing sections Piezas del cárter 机身零件	3 - 1
3.02	Kopfteile Needle head parts Piezas de la cabeza 机头零件	3 - 2
3.03	Armteile Arm parts Piezas del brazo 机臂零件	3 - 5
3.04	Grundplattenteile Bedplate parts Piezas del cárter 底板零件	3 - 11
4	Garnrollenständer Reel stands Portacarretes 线轴支架	4 - 1
5	Knielüfterteile Knee lifter parts Piezas del alzaprensatelas por rodillera 膝松线器零件	5 - 1
6	Teile zur Tischplatte Parts for table top Piezas para el tablero 用于台板的零件	6 - 1
7	Keilriemen V-belt Correa trapezoidal 三角皮带	7 - 1
8	Schmiermittel-Übersicht Overview of lubricants Tabla de lubricantes 润滑剂一览	8 - 1
9	Index (Teilenummern / Seitenzahlen) Index (part numbers / page numbers) Index (números de pieza / números de página) 注脚(零件号/页号)	9 - 1
10.01	Nähwerkzeuge Gauge parts Organos de costura 缝纫工具	10 - 2

Achtung!



Wir machen ausdrücklich darauf aufmerksam, daß Ersatz- und Zubehörteile, die nicht von uns geliefert werden, auch nicht von uns geprüft und freigegeben sind. Der Einbau und / oder die Verwendung solcher Produkte kann daher u. Umständen konstruktiv vorgegebene Eigenschaften Ihrer Maschine negativ verändern. Für Schäden, die durch die Verwendung von Nicht-Originalteilen entstehen, übernehmen wir keine Haftung!
Originalteile sind mit einem " P " oder der PFAFF-Teilenummer gekennzeichnet.

Caution!



We warn you expressly that spare parts and accessories that are not supplied by us are not tested and released by us. Fitting or using these products may therefore have negative influences on features that depend on the machine design. We are not liable for any damage caused by the use of non-Pfaff parts! Original parts are marked with a " P " or with the PFAFF part number.

¡Atención!



Se hace observar que en el caso de piezas de recambio y accesorios que no hayan sido suministrados por nosotros, quiere decir que non han sido sometidas por nuestra parte a un control y que no se les ha dado el visto bueno. Por esta razón, el montaje y/o empleo de tales productos puede repercutir negativamente en las características previstas en su máquina.
¡Para los daños que eventualmente pudiesen presentarse al utilizar piezas no originales, no asumimos ninguna garantía!
Las piezas originales se identifican con " P " o con el número de referencia de pieza de PFAFF.

注意!



我们必须明确指出，所有不是由我们供货的备件和附件都未经我们检查，也没有被我们批准使用。装入和/或使用这些产品可能在一定的情况下会对机器的设计特性造成负面改变。对由于使用非原装件所造成的损失，我们不负任何责任！
原装零件用字母 " P " 或者 PFAFF 零件号加标记。

- Die Seriennummer der Maschine, für die diese Teileliste Gültigkeit hat, ist auf der Titelseite aufgeführt.
 - Alle Teile sind so abgebildet, wie sie in der Maschine funktionsmäßig zusammengehören.
 - Gestrichelt dargestellte Teile zeigen angrenzende Teile aus anderen Funktionsgruppen.
 - Im oberen Teil der Bildseiten befindet sich eine Gesamtansicht der Maschine .
 - Der Einbauort der dargestellten Teile wird durch eine gerasterte Fläche gekennzeichnet.
 - Einrahmungen auf den Bildseiten zeigen, aus welchen Einzelteilen sich die Gruppenteile zusammensetzen.
 - Die auf den Bildseiten verwendeten Schlüsselzeichen (; 2 ; 3 usw.) sind im Kapitel "Erläuterungen der Schlüsselzeichen" aufgelistet.
-
- The serial number of the machine to which this parts list applies is indicated on the cover page.
 - All parts are illustrated in function groups with the parts which they function together with in the machine.
 - Parts illustrated with broken lines are parts from other function groups which border on the illustrated function group.
 - The above section of the page of illustrations contains a total view of the machine. The place for the installation of the parts pictured here is marked by the grid.
 - The framed-in sections on the illustration pages show the individual parts comprising a group.
 - The key markings used on the illustrated pages (; 2 ; 3 etc.) are listed in the chapter "Explanation of key markings".
-
- El número de serie de la máquina para la cual tiene validez esta lista de piezas va indicado en la página de título.
 - Todas las piezas están ilustradas tal como aparecen en la máquina para su funcionamiento.
 - Las piezas representadas con rayitas muestran piezas colindantes de otros grupos de funciones.
 - En la parte superior de las páginas ilustradas se puede ver una vista en conjunto de la máquina.
 - El lugar de montaje de la pieza representada va caracterizada mediante una superficie reticulada.
 - Los recuadros en las páginas ilustradas indican las piezas individuales de que se componen los grupos.
 - Los signos clave (; 2 ; 3 etc.) empleados en las páginas con ilustraciones van listados en el capítulo "Explicaciones de los signos clave".
-
- 适用于本零件表的机器系列号列在首页上。
 - 所有的零件都按照其在机器中的功能情况合在一起表达。
 - 用虚线表示的零件为相邻功能组中的零件。
 - 图的上部为机器全景。
 - 所示零件的安装部位用影格面表示。
 - 页上的框表示这套组件都由哪些零件所组成。
 - 图页上所使用的标记 (; 2 ; 3 等) 列表在“标记说明”中。

- Unterklassenabhängig, Teilenummer siehe Unterklassen-Ausstattung.**
Subclas-dependent, for part number see subclass parts listing.
Dependientes de la subclase, para el número de pieza véase "Dotación de subclases".
取决于子机型，零件号见子机型设备。
- 6** **Nadeldicke und Spitzenform bei Bestellung angeben.**
Needle size and style of point to be stated on order.
Grosor de aguja y forma de la punta, indíquese en los pedidos.
在订货时给出针厚和针尖型式。
- 40/2** **Tränken mit 28-011 201-44; Bestellnummer siehe Seite 8 - 1.**
Grease with 28-011 201-44; for part number see page 8 - 1.
Engrase con grasa 28-011 201-44; para el número de pedido véase la página 8 - 1.
浸油用 28-011 201-44; 订货号见 8 - 1页。
- 40/4** **Fetten mit 28-011 202-43; Bestellnummer siehe Seite 8 - 1.**
Grease with 28-011 202-43; for part number see page 8 - 1.
Engrase con grasa 28-011 202-43; para el número de pedido véase la página 8 - 1.
上脂用 28-011 202-43; 订货号见 8 - 1页。
- 96** **Länge angeben**
State length
Indíquese la largura
给出长度

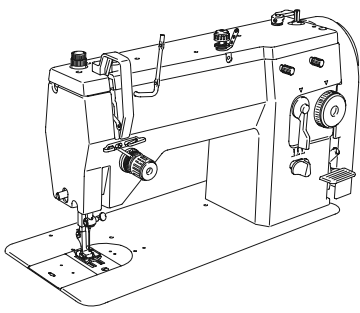

Gehäuseteile
Housing sections
Piezas del cárter
机身零件

PFAFF 114

3.01

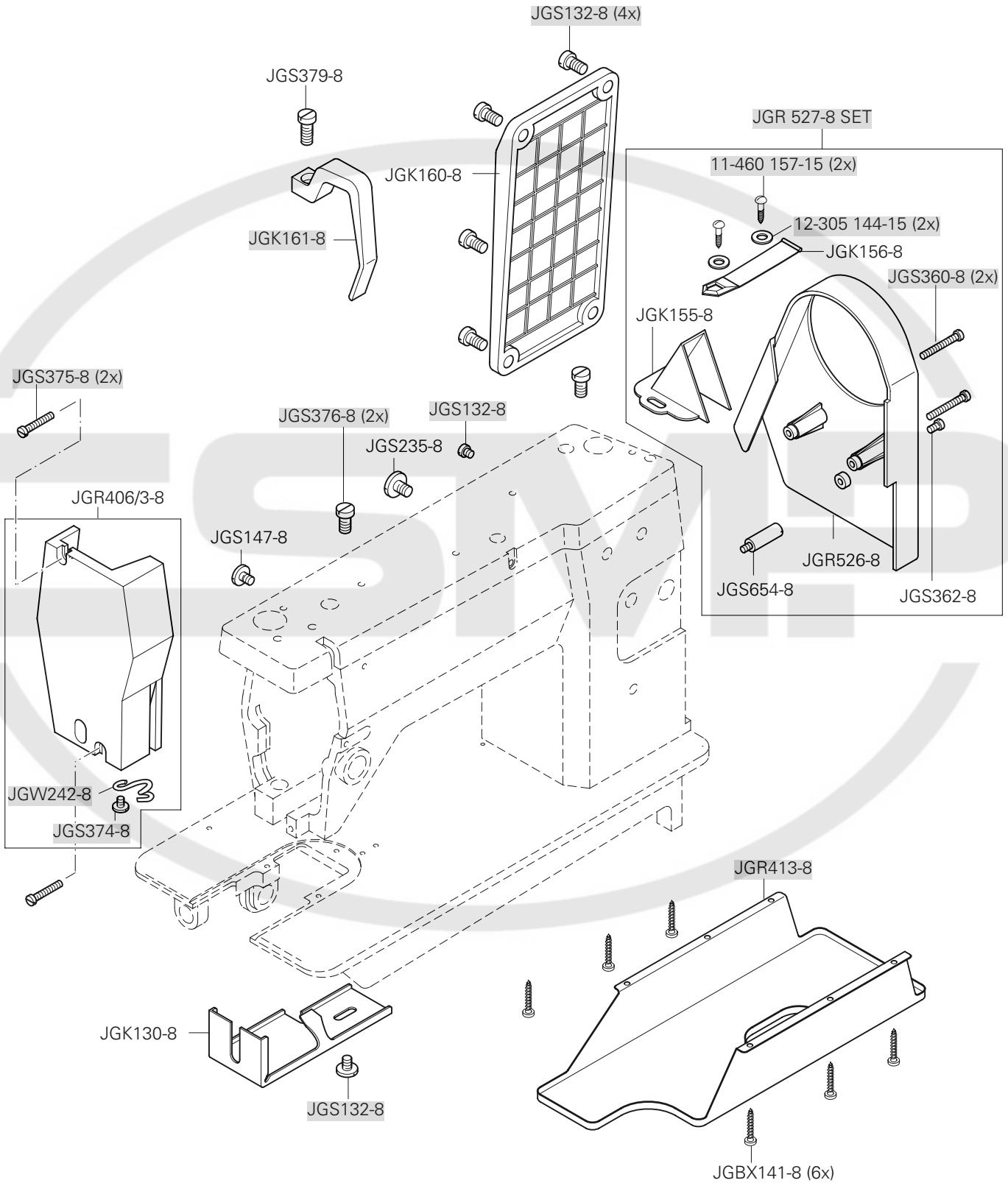

3.02

Kopfteile
Needle head parts
Piezas de la cabeza
机头零件

PFAFF 114

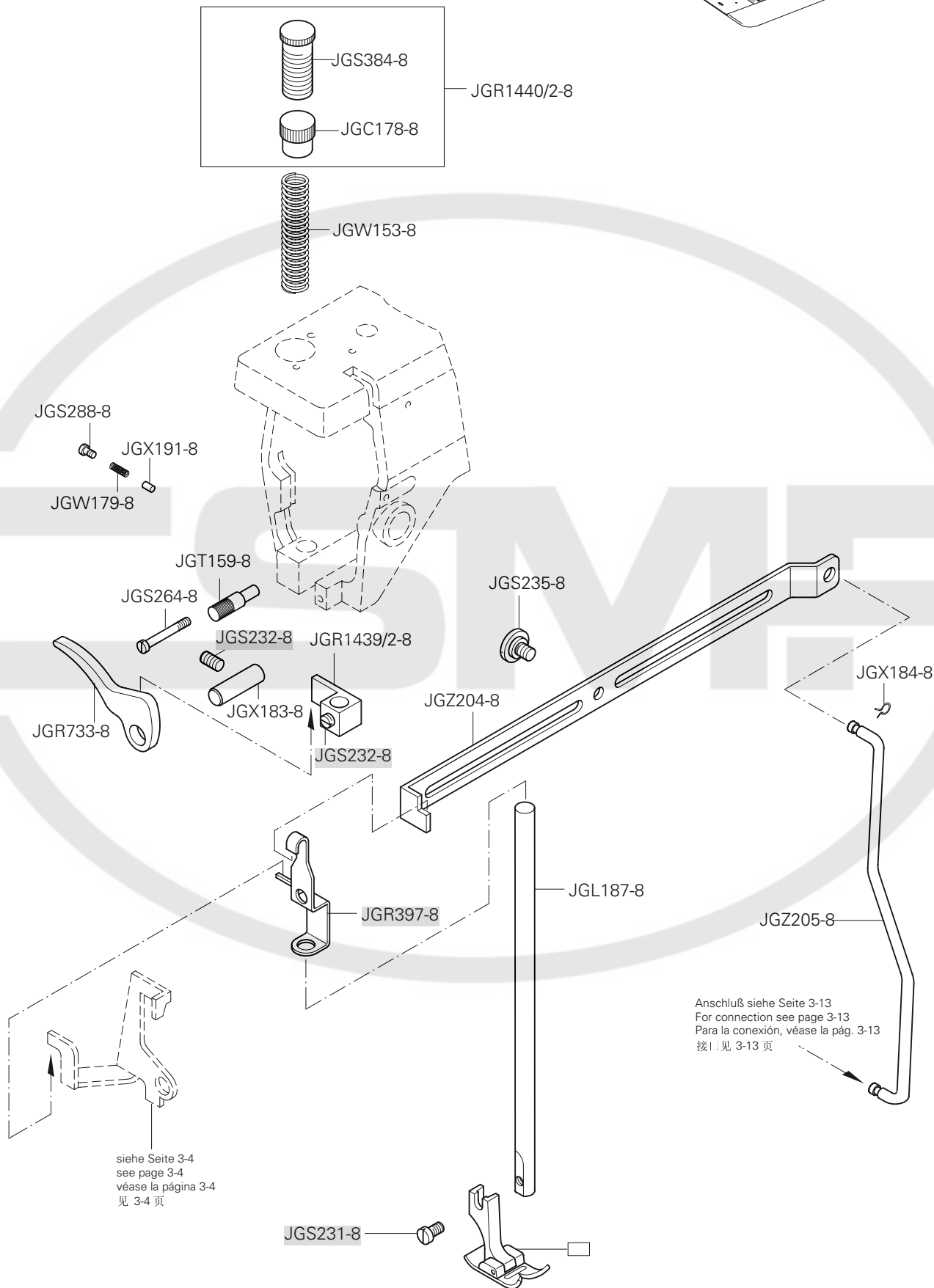
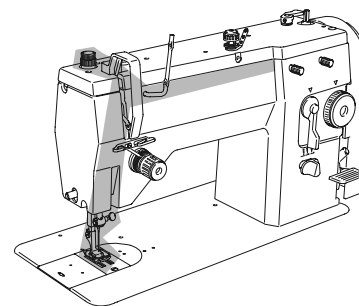

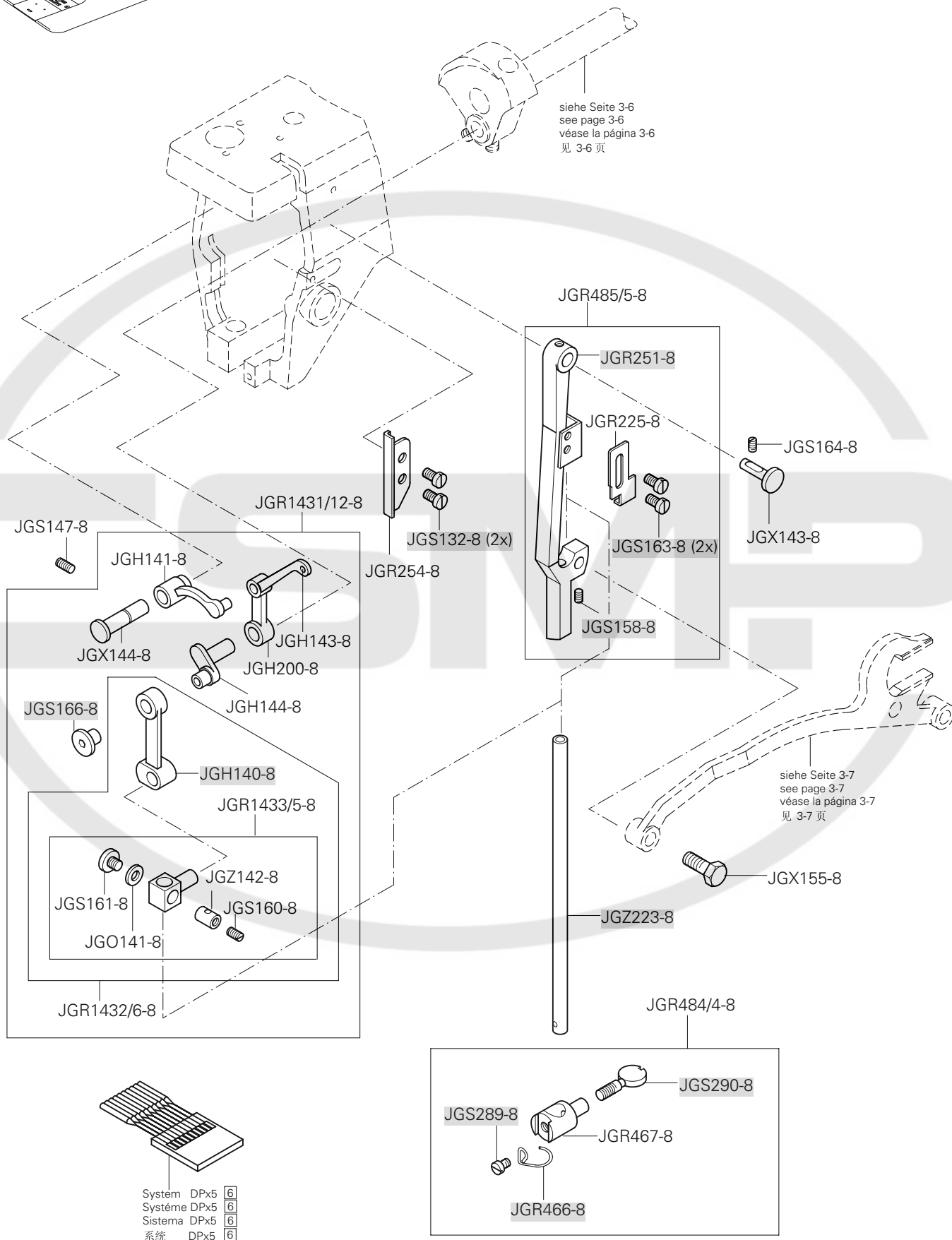
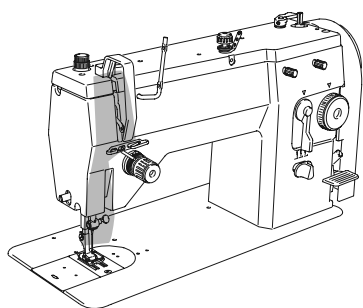

3.02

Kopfteile
Needle head parts
Piezas de la cabeza
机头零件

PFAFF 114

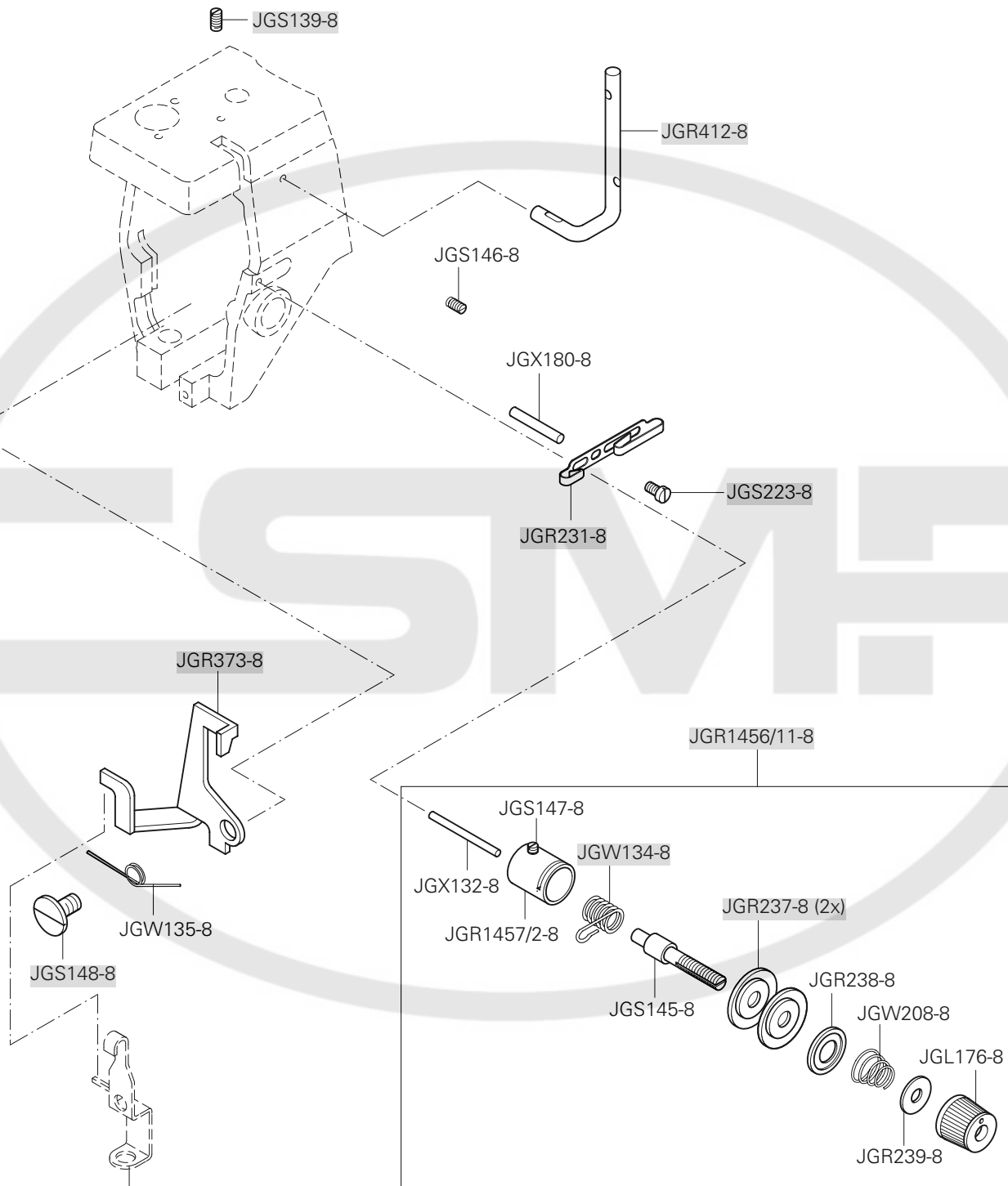
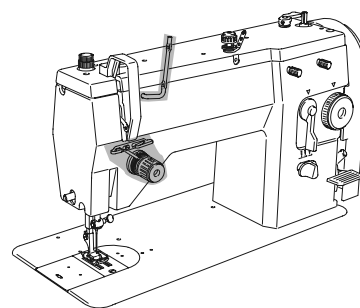

siehe Seite 3-2
see page 3-2
véase la página 3-2
见 3-2 页

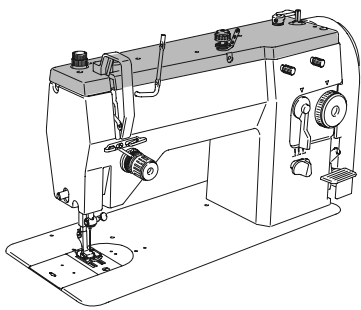

Armteile
 Arm parts
 Piezas del brazo
 机臂零件

PFAFF 114

3.03

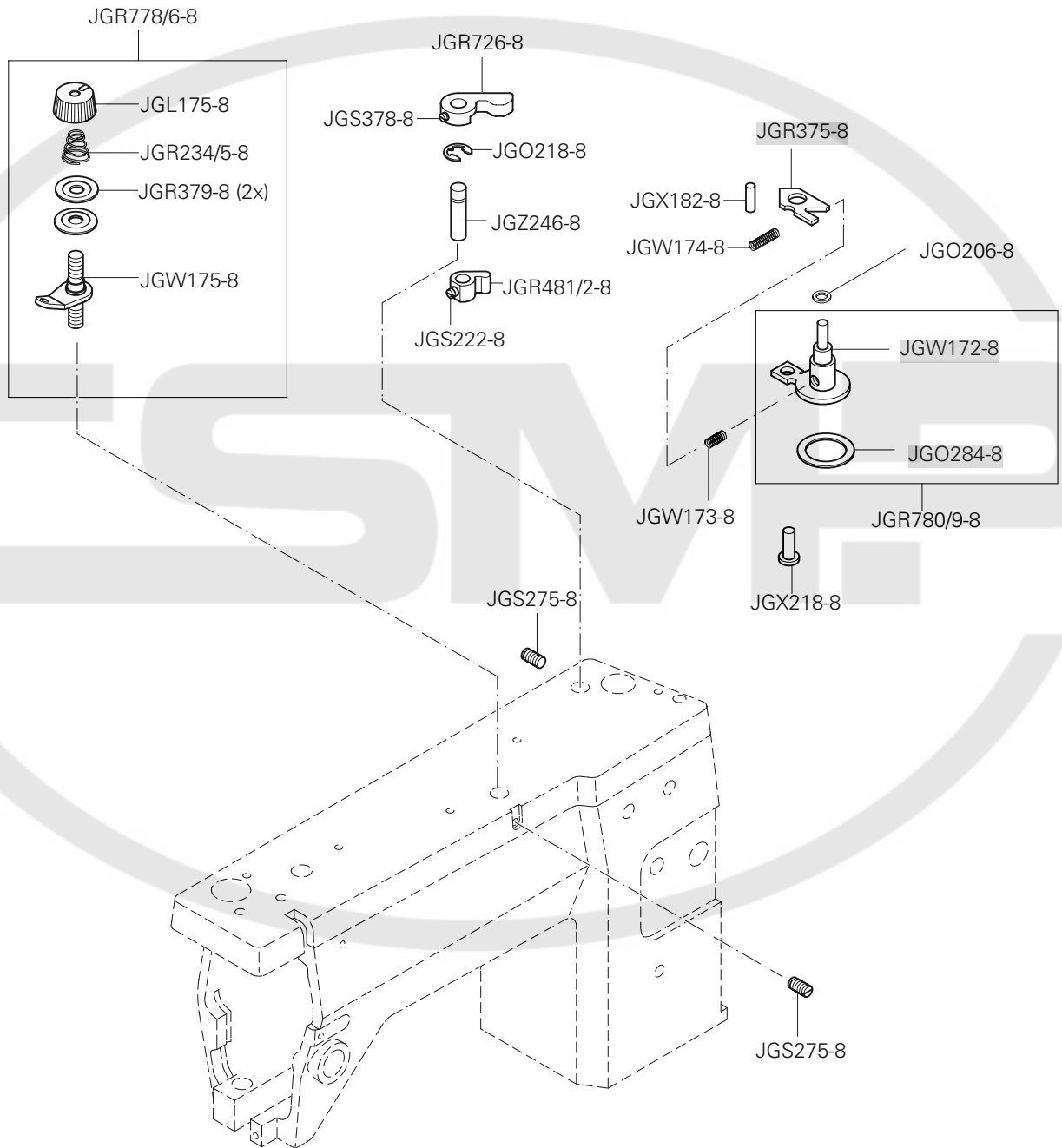

3.03

Armteile Arm parts Piezas del brazo 机臂零件

PFAFF 114

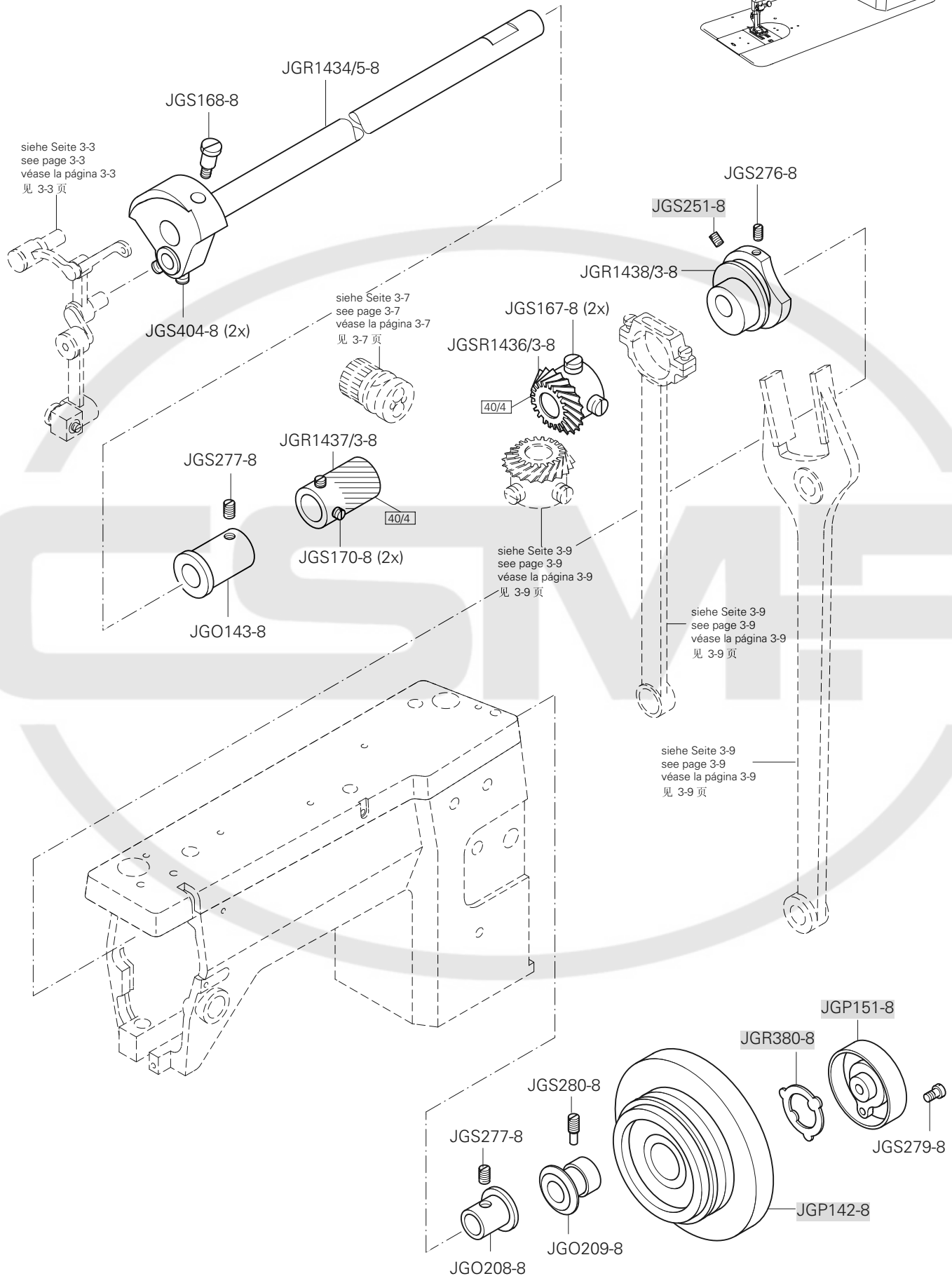
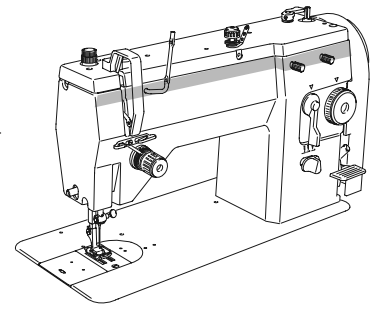

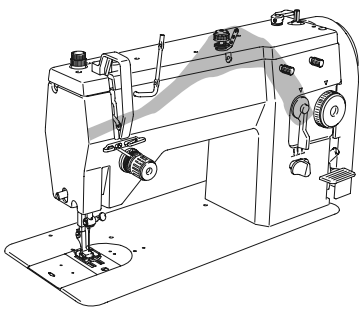

Armteile
 Arm parts
 Piezas del brazo
 机臂零件

PFAFF 114

3.03

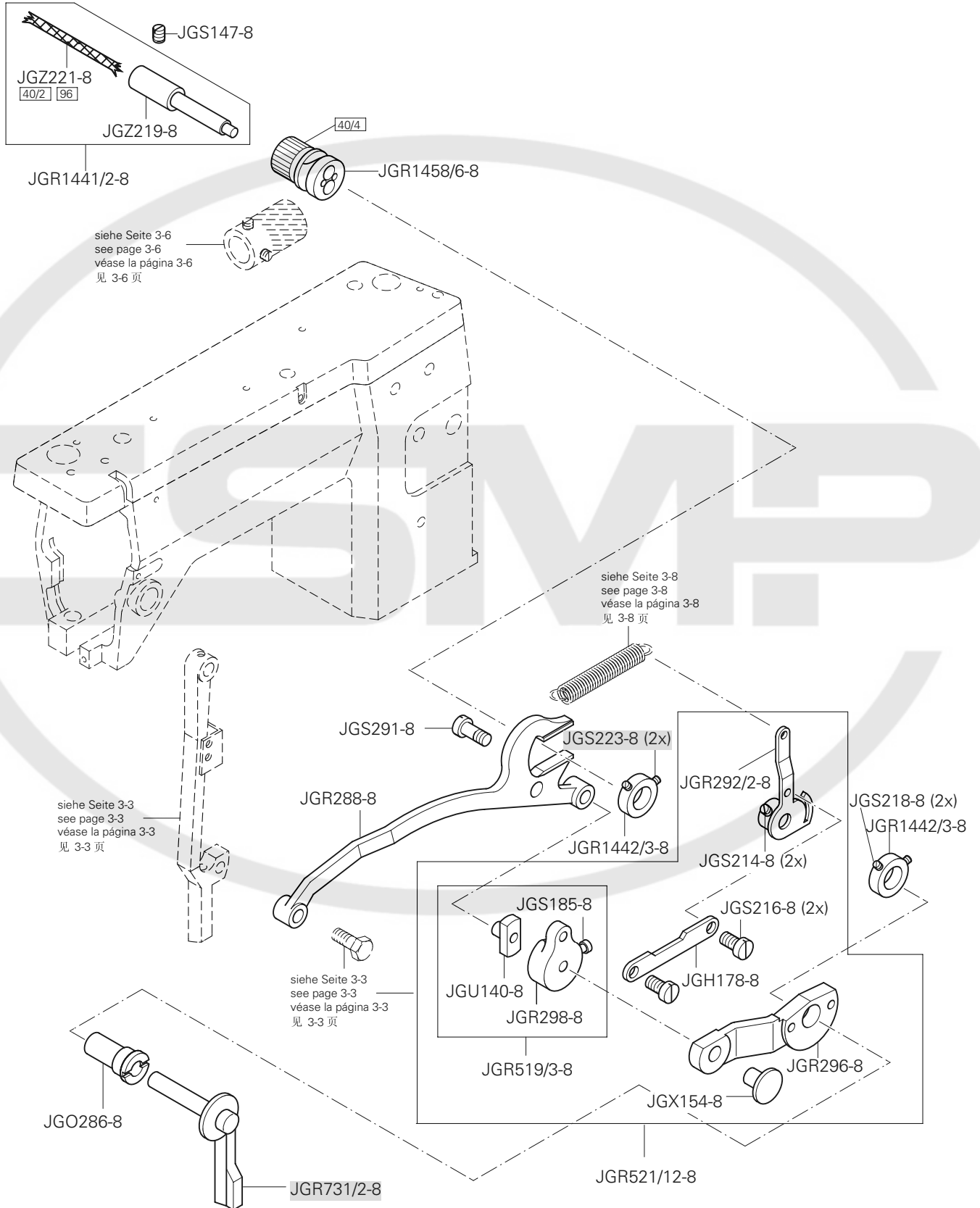

3.03

Armteile
 Arm parts
 Piezas del brazo
 机臂零件

PFAFF 114

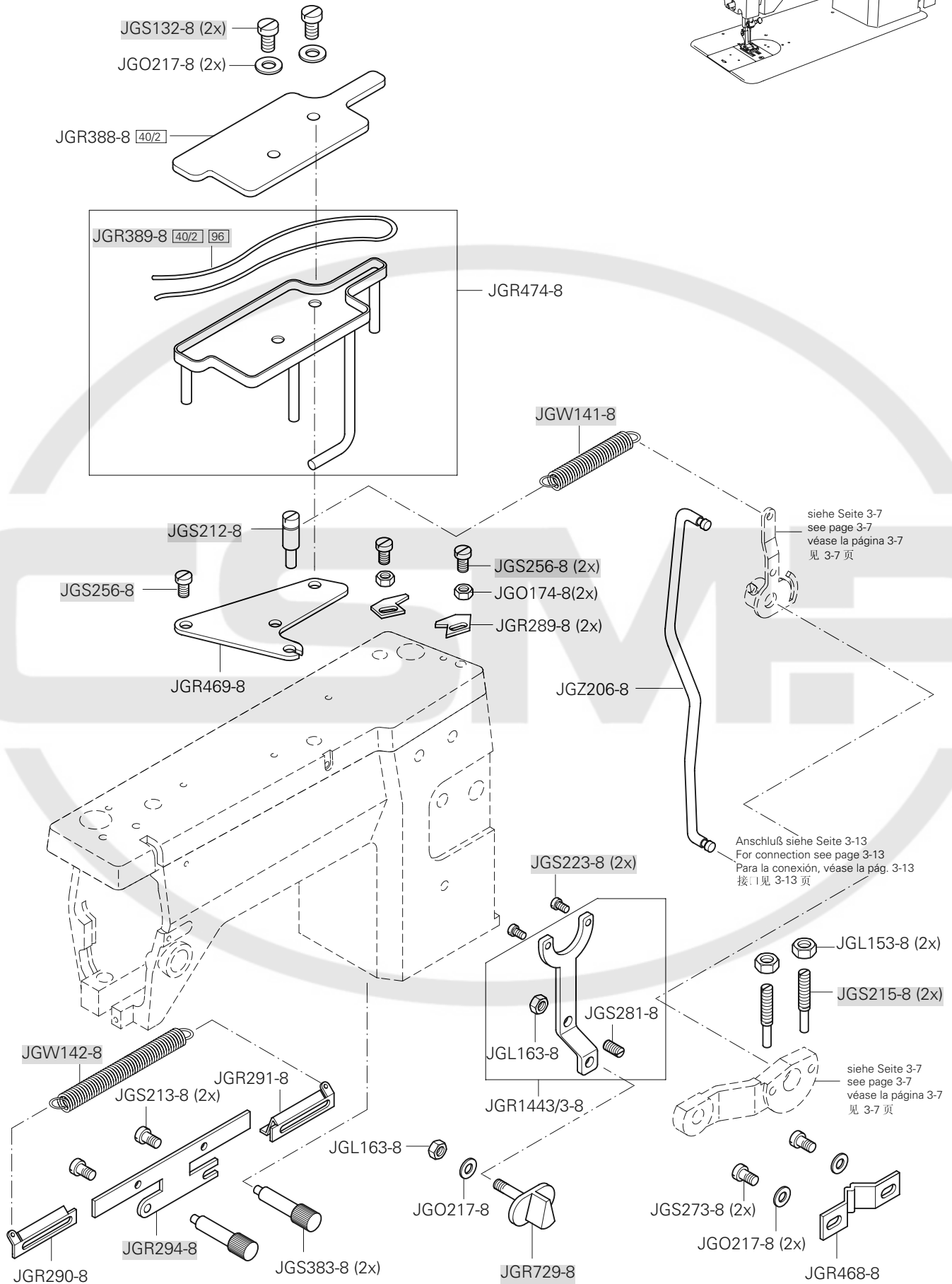
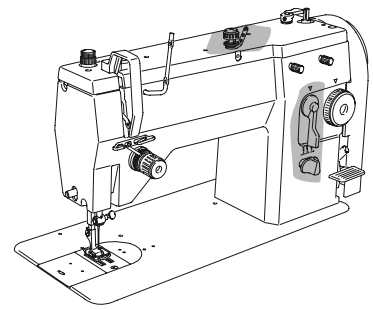

Armteile
 Arm parts
 Piezas del brazo
 机臂零件

PFAFF 114

3.03

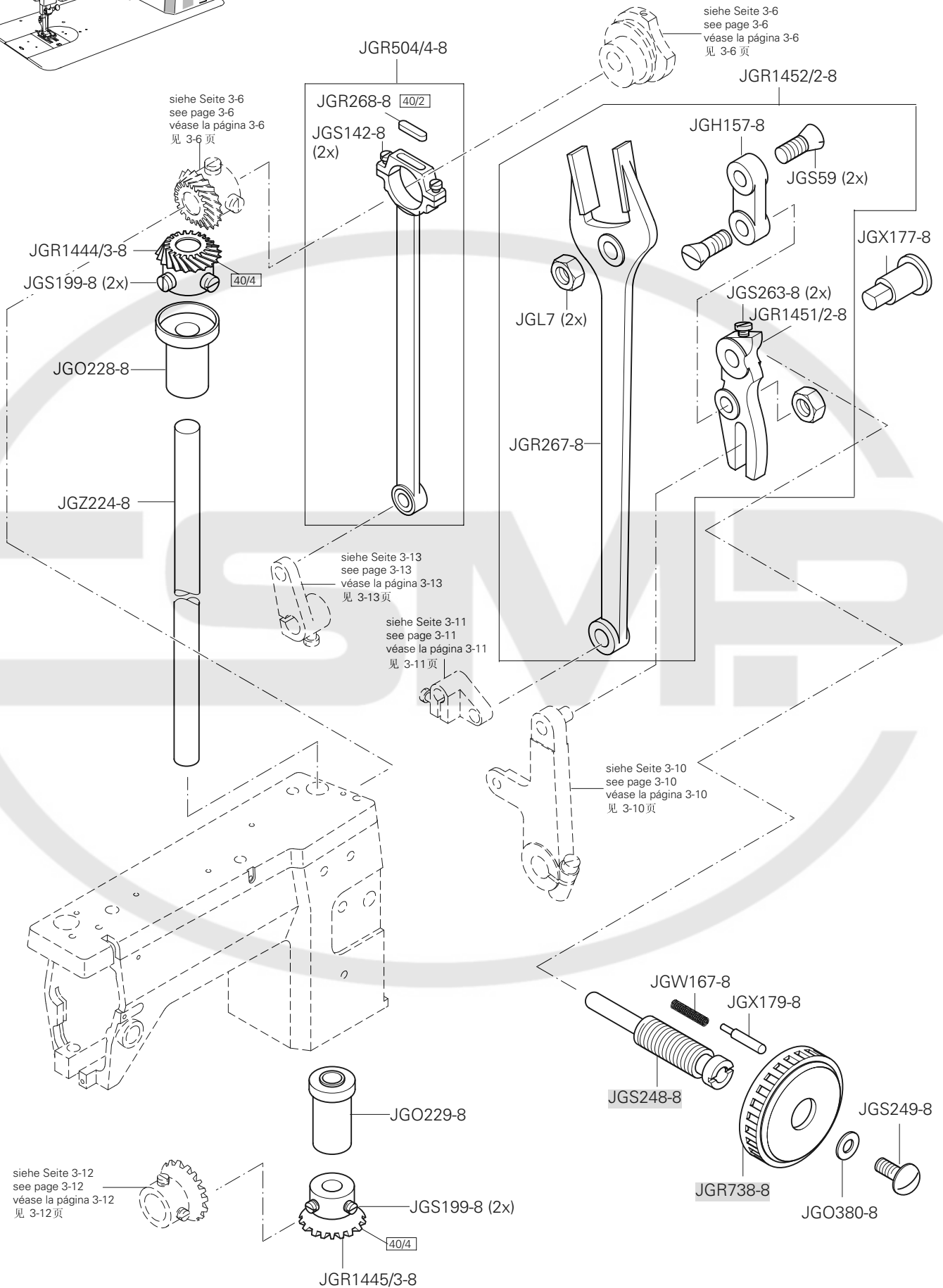
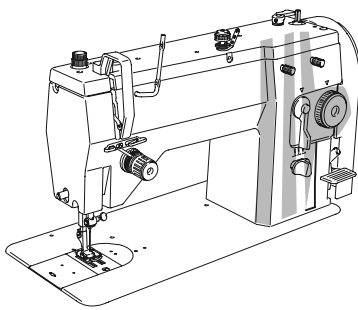

3.03

Armteile
 Arm parts
 Piezas del brazo
 机臂零件

PFAFF 114

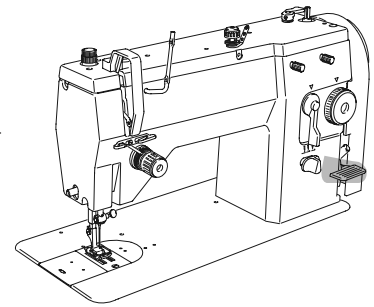

siehe Seite 3-9
 see page 3-9
 véase la página 3-9
 见 3-9 页

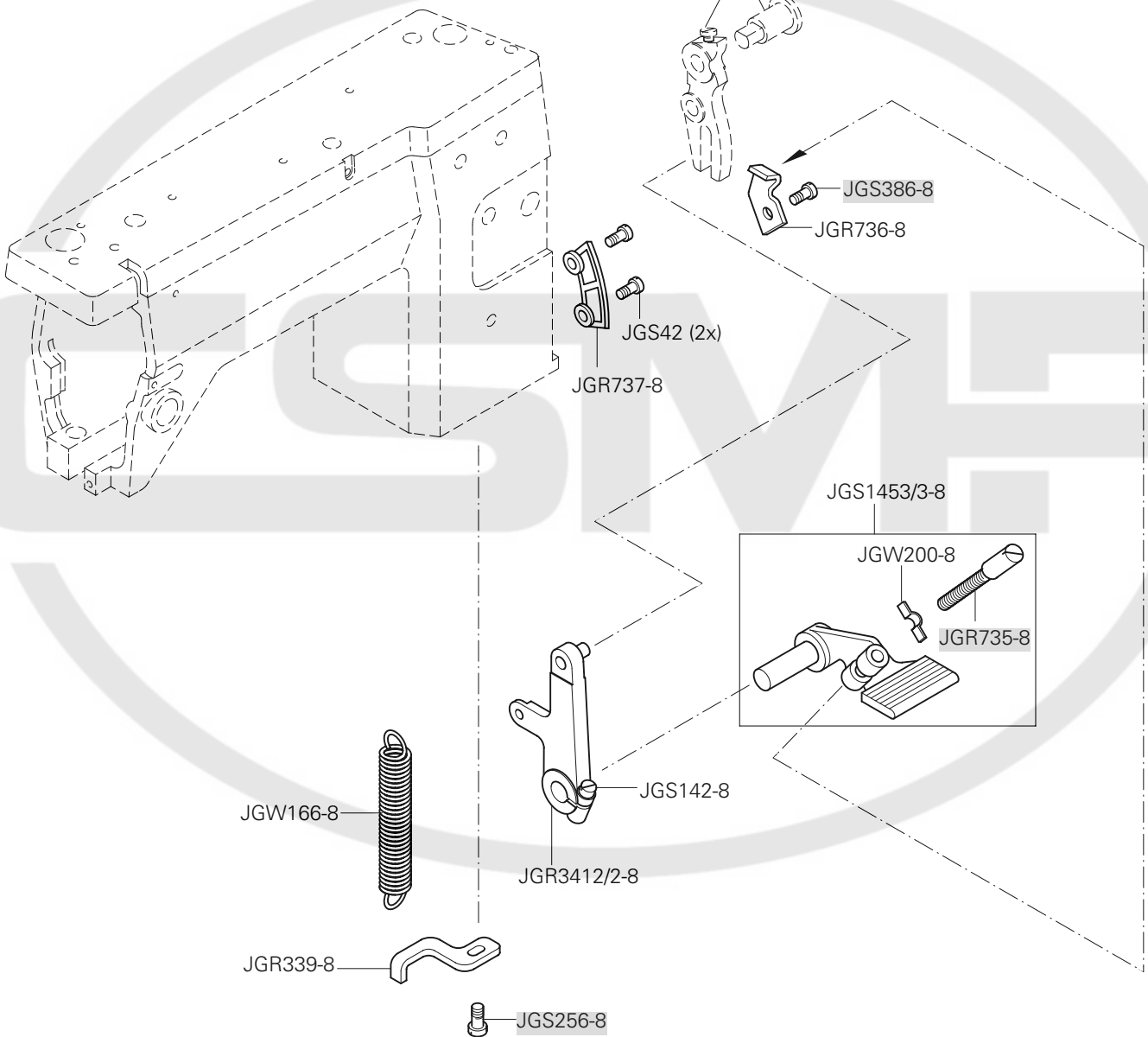

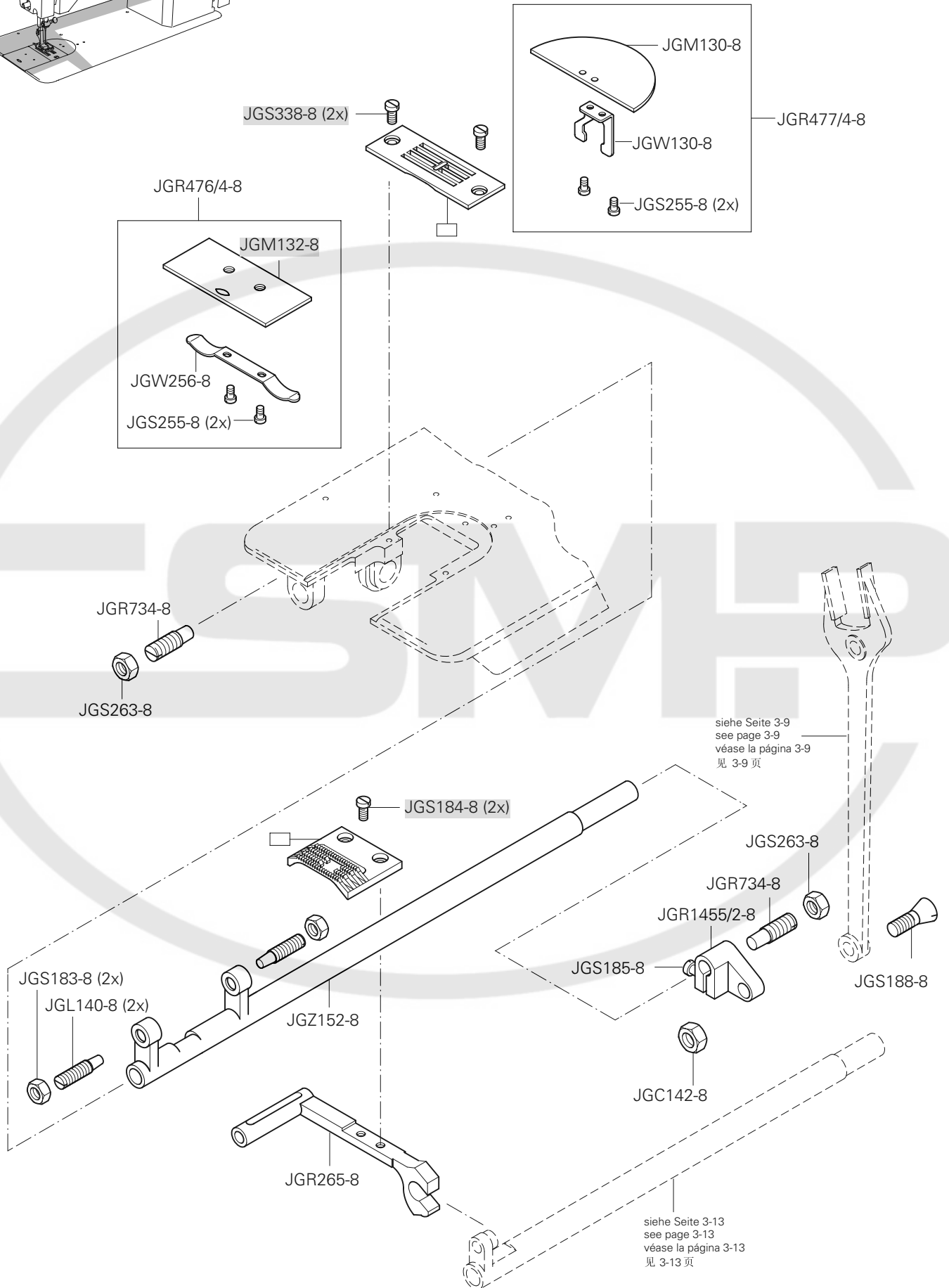
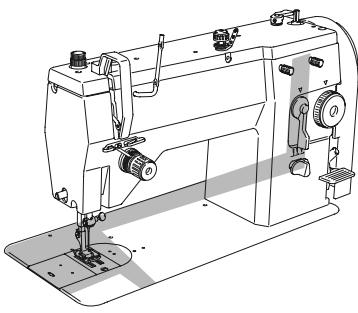

3.04

Grundplattenteile
Bedplate parts
Piezas del cárter
底板零件

PFAFF 114

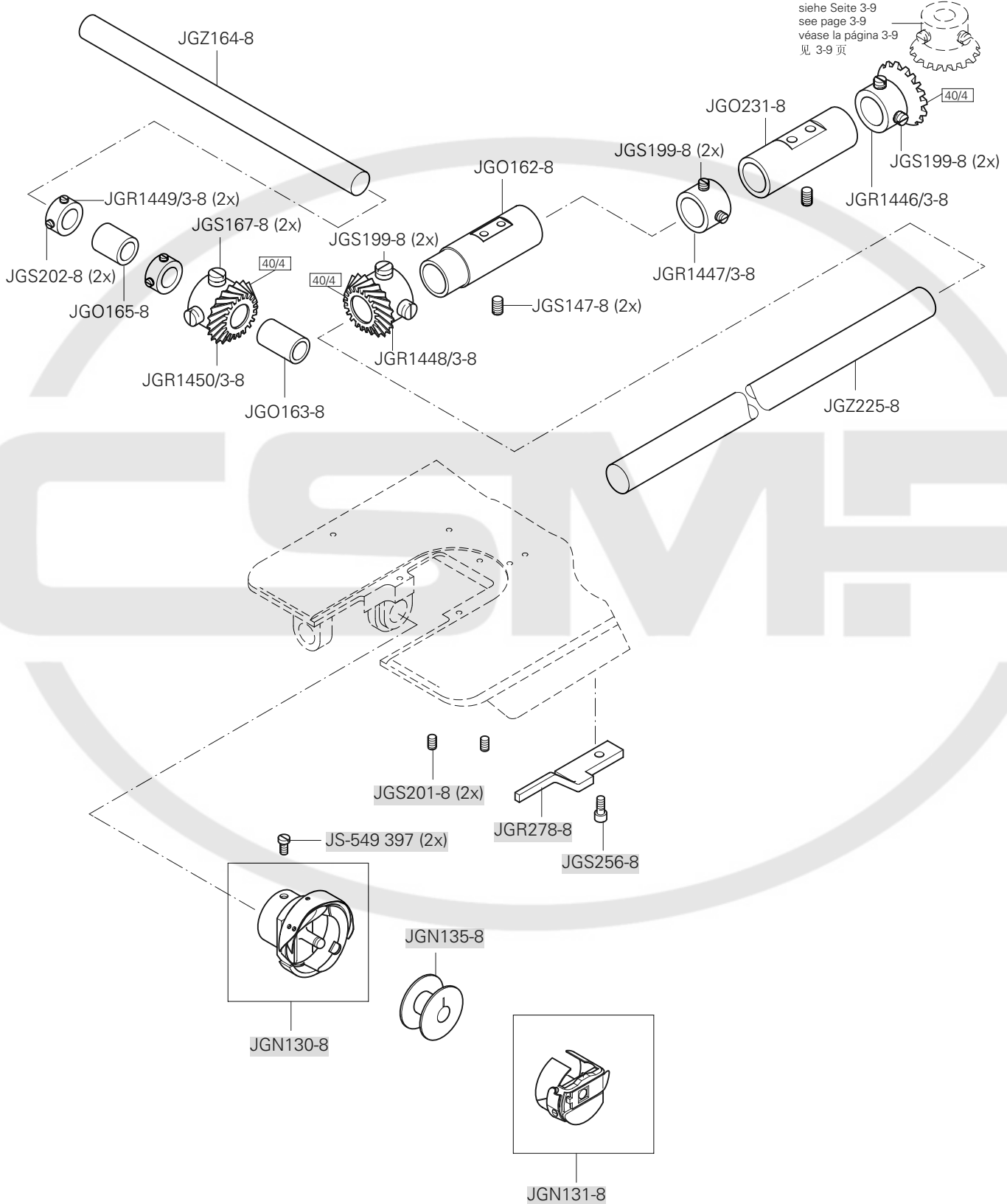
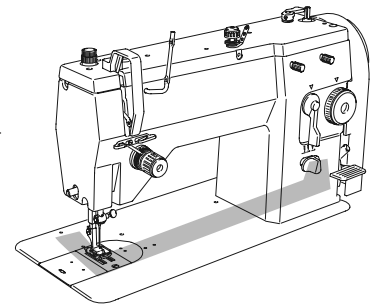

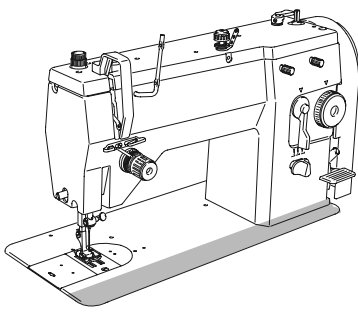

Grundplattenteile
Bedplate parts
Piezas del cárter
底板零件

PFAFF 114

3.04

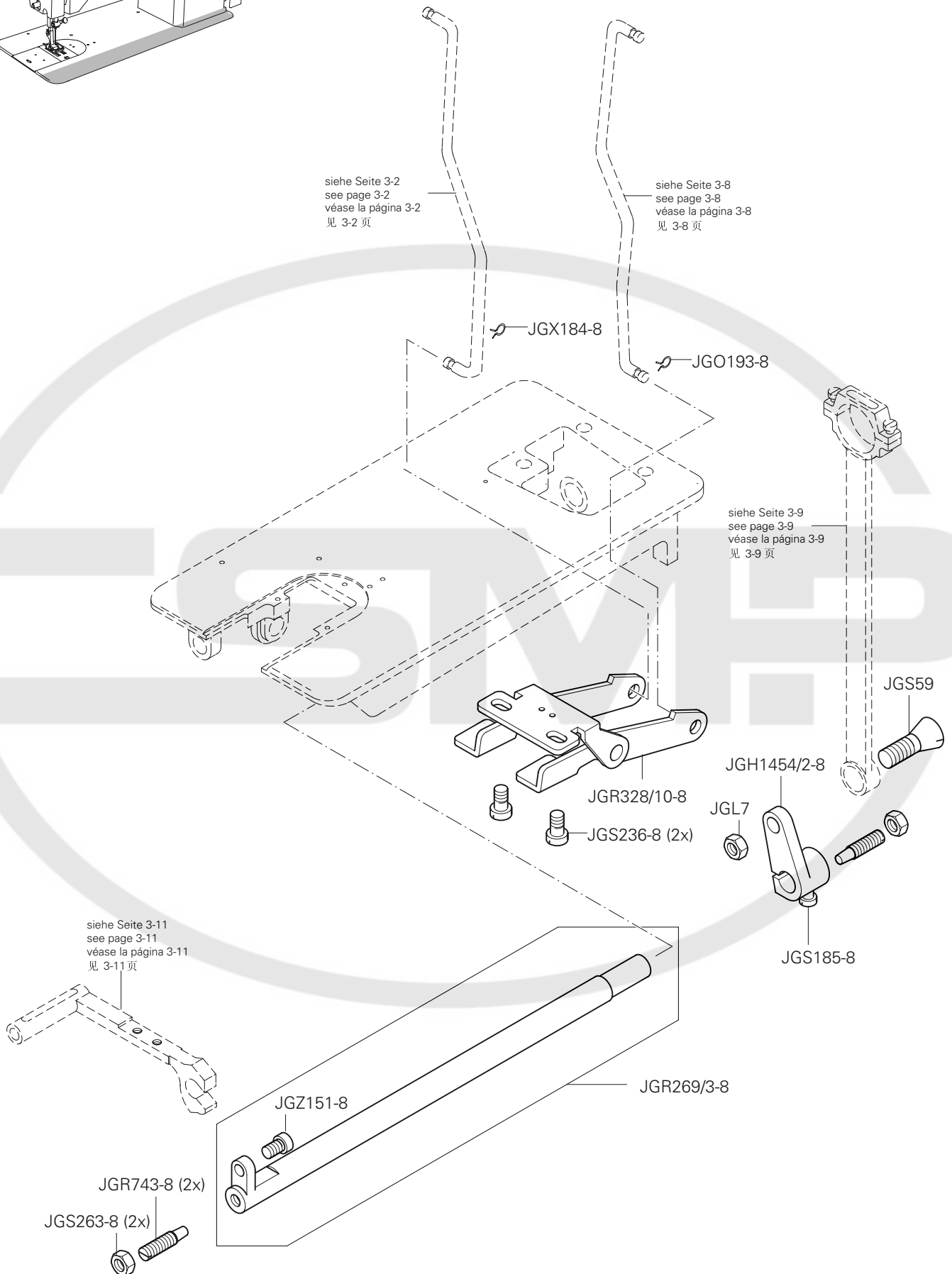

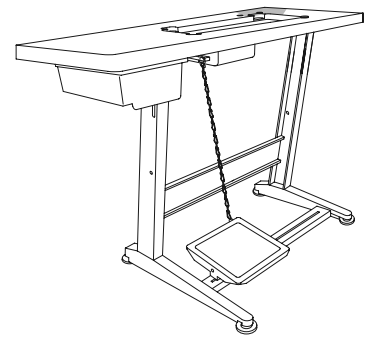

JGR760/25-8

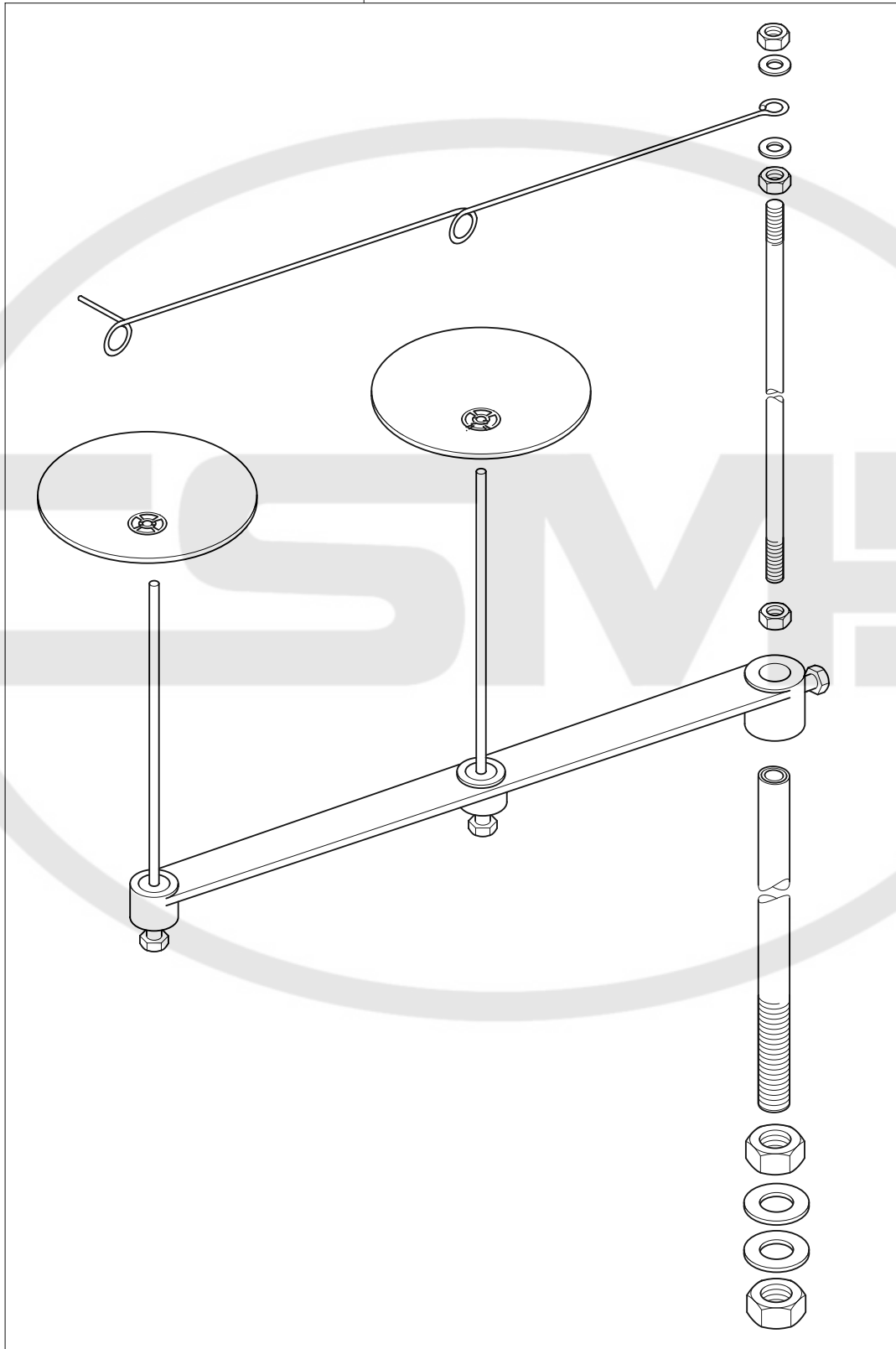

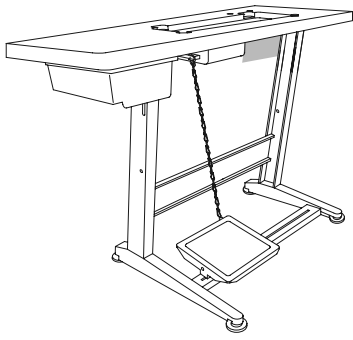

Knielüfterteile
 Knee lifter parts
 Piezas del alzaprensatelas por rodillera
 膝松线器零件

PFAFF 114

JGR1315/18-8

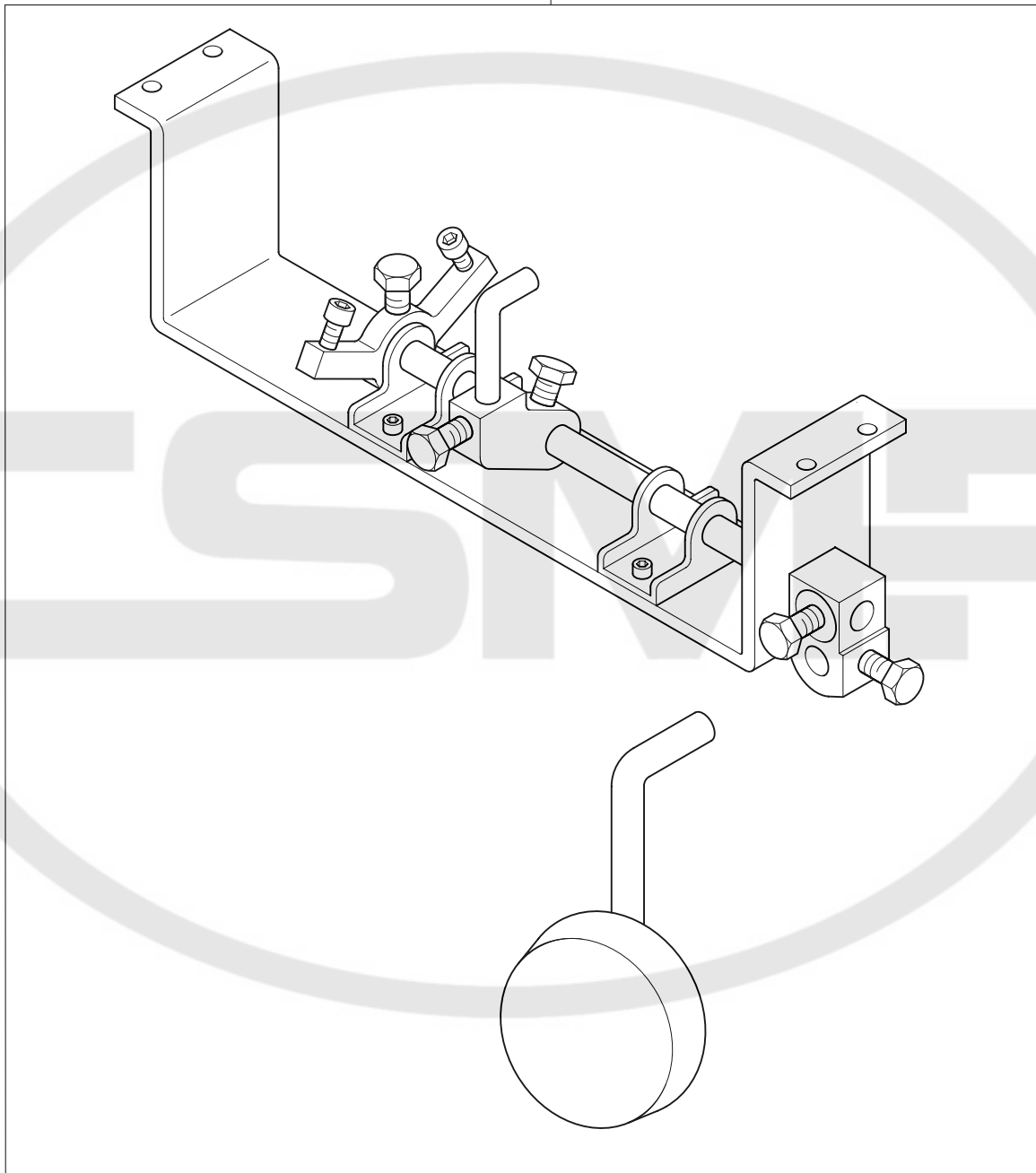

6

Teile zur Tischplatte
 Parts for table top
 Piezas para el tablero
 用于台板的零件

PFAFF 114

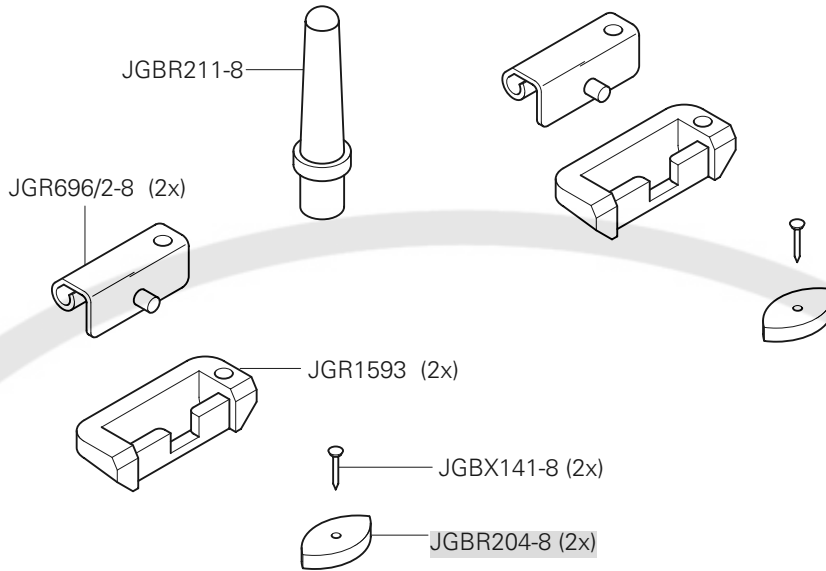

7

Keilriemen
 V-belt
 Correa trapezoidal
 三角皮带

PFAFF 114

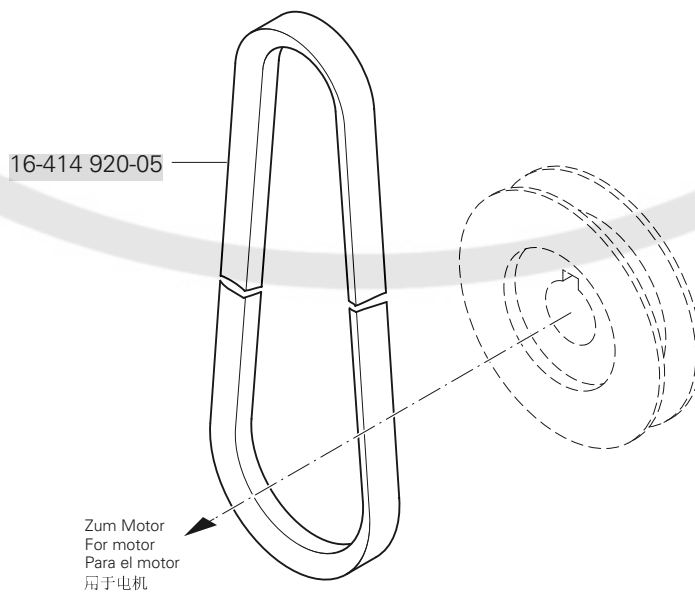

Öl Oil Aceite 油	Mittelpunkts-Viskosität bei: Mean viscosity at: Viscosidad media a: 中点粘度:		Dichte bei: Density of: Densidad a: 密度, 在:		Bestellnummer für Behälter mit: Part number for can with: Número de pedido para recipientes con: 订货号用于油箱, 带:		
	°C	mm ² /s	°C	g/cm ³ (g/ml)	1 Liter 1 Litre 1 Litro 1 升	5 Liter 5 Litre 5 Litros 5 升	10 Liter 10 Litre 10 Litros 10 升
28-011 201-44	40	22,0	15	0,865	91-027 917-91		

Fett Grease Grasa 脂	Penetration Penetration Penetración 贯入度	Tropfpunkt Drip-point Punto de goteo 滴点	Bestellnummer für Behälter mit: Part number for can with: Número de pedido para recipientes con: 订货号用于油箱, 带:		
			mm/10	°C	0,25 kg
28-011 202-43	375-405	150		28-011 202-43	

Reinigungsmittel Cleansing agent Limpiadores 清洁剂	Bestellnummer für Behälter mit: Part number for can with: Número de pedido para recipientes con: 订货号用于油箱, 带: 240 ml
Isoprophyl-Alkohol 异丙醇	95-665 735-91

No. 零件号	Seite Page Página 页号	No. 零件号	Seite Page Página 页号	No. 零件号	Seite Page Página 页号	No. 零件号	Seite Page Página 页号
11-460 157-15	3 - 1	JGL7	3 - 9, 3 - 13	JGR1438/3-8	3 - 6	JGR288-8	3 - 7
12-305 144-15	3 - 1	JGM130-8	3 - 11	JGR1439/2-8	3 - 2	JGR289-8	3 - 8
16-414 920-05	6 - 1	JGM132-8	3 - 11	JGR1440/2-8	3 - 2	JGR290-8	3 - 8
28-011 201-44	8 - 1	JGN130-8	3 - 12	JGR1441/2-8	3 - 7	JGR291-8	3 - 8
28-011 202-43	8 - 1	JGN131-8	3 - 12	JGR1442/3-8	3 - 7	JGR292/2-8	3 - 7
91-027 917-91	8 - 1	JGN135-8	3 - 12	JGR1443/3-8	3 - 8	JGR294-8	3 - 8
91-027 919-91	8 - 1	JGO141-8	3 - 3	JGR1444/3-8	3 - 9	JGR296-8	3 - 7
91-027 920-91	8 - 1	JGO143-8	3 - 6	JGR1445/3-8	3 - 9	JGR298-8	3 - 7
95-665 735-91	8 - 1	JGO162-8	3 - 12	JGR1446/3-8	3 - 12	JGR328/10-8	3 - 13
JGBR204-8	6 - 1	JGO163-8	3 - 12	JGR1447/3-8	3 - 12	JGR339-8	3 - 10
JGBR211-8	6 - 1	JGO165-8	3 - 12	JGR1448/3-8	3 - 12	JGR3412/2-8	3 - 10
JGBX141-8	3 - 1, 6 - 1	JGO174-8	3 - 8	JGR1449/3-8	3 - 12	JGR373-8	3 - 4
JGC142-8	3 - 11	JGO193-8	3 - 13	JGR1450/3-8	3 - 12	JGR375-8	3 - 5
JGC178-8	3 - 2	JGO206-8	3 - 5	JGR1451/2-8	3 - 9	JGR379-8	3 - 5
JGH140-8	3 - 3	JGO208-8	3 - 6	JGR1452/2-8	3 - 9	JGR380-8	3 - 6
JGH141-8	3 - 3	JGO209-8	3 - 6	JGR1455/2-8	3 - 11	JGR388-8	3 - 8
JGH143-8	3 - 3	JGO217-8	3 - 8	JGR1456/11-8	3 - 4	JGR389-8	3 - 8
JGH144-8	3 - 3	JGO218-8	3 - 5	JGR1457/2-8	3 - 4	JGR397-8	3 - 2
JGH1454/2-8	3 - 13	JGO228-8	3 - 9	JGR1458/6-8	3 - 7	JGR406/3-8	3 - 1
JGH157-8	3 - 9	JGO229-8	3 - 9	JGR1593	6 - 1	JGR412-8	3 - 4
JGH178-8	3 - 7	JGO231-8	3 - 12	JGR225-8	3 - 3	JGR413-8	3 - 1
JGH200-8	3 - 3	JGO284-8	3 - 5	JGR231-8	3 - 4	JGR466-8	3 - 3
JGK130-8	3 - 1	JGO286-8	3 - 7	JGR234/5-8	3 - 5	JGR467-8	3 - 3
JGK155-8	3 - 1	JGO380-8	3 - 9	JGR237-8	3 - 4	JGR468-8	3 - 8
JGK156-8	3 - 1	JGP142-8	3 - 6	JGR238-8	3 - 4	JGR469-8	3 - 8
JGK160-8	3 - 1	JGP151-8	3 - 6	JGR239-8	3 - 4	JGR474-8	3 - 8
JGK161-8	3 - 1	JGR1315/18-8	5 - 1	JGR251-8	3 - 3	JGR476/4-8	3 - 11
JGL140-8	3 - 11	JGR1431/12-8	3 - 3	JGR254-8	3 - 3	JGR477/4-8	3 - 11
JGL153-8	3 - 8	JGR1432/6-8	3 - 3	JGR265-8	3 - 11	JGR481/2-8	3 - 5
JGL163-8	3 - 8	JGR1433/5-8	3 - 3	JGR267-8	3 - 9	JGR484/4-8	3 - 3
JGL175-8	3 - 5	JGR1434/5-8	3 - 6	JGR268-8	3 - 9	JGR485/5-8	3 - 3
JGL176-8	3 - 4	JGR1436/3-8	3 - 6	JGR269/3-8	3 - 13	JGR504/4-8	3 - 9
JGL187-8	3 - 2	JGR1437/3-8	3 - 6	JGR278-8	3 - 12	JGR519/3-8	3 - 7

No. 零件号	Seite Page Página 页号	No. 零件号	Seite Page Página 页号	No. 零件号	Seite Page Página 页号	No. 零件号	Seite Page Página 页号
JGR521/12-8	3 - 7	JGS170-8	3 - 6	JGS281-8	3 - 8	JGW175-8	3 - 5
JGR526-8	3 - 1	JGS183-8	3 - 11	JGS288-8	3 - 2	JGW179-8	3 - 2
JGR527-8SET	3 - 1	JGS184-8	3 - 11	JGS289-8	3 - 3	JGW200-8	3 - 10
JGR696/2-8	6 - 1	JGS185-8	3 - 7, 3 - 11, 3 - 13	JGS290-8	3 - 3	JGW208-8	3 - 4
JGR726-8	3 - 5	JGS188-8	3 - 11	JGS291-8	3 - 7	JGW242-8	3 - 1
JGR729-8	3 - 8	JGS199-8	3 - 9, 3 - 12	JGS338-8	3 - 11	JGW256-8	3 - 11
JGR731/2-8	3 - 7	JGS201-8	3 - 12	JGS360-8	3 - 1	JGX132-8	3 - 4
JGR733-8	3 - 2	JGS202-8	3 - 12	JGS362-8	3 - 1	JGX143-8	3 - 3
JGR734-8	3 - 11	JGS212-8	3 - 8	JGS374-8	3 - 1	JGX144-8	3 - 3
JGR735-8	3 - 10	JGS213-8	3 - 8	JGS375-8	3 - 1	JGX154-8	3 - 7
JGR736-8	3 - 10	JGS214-8	3 - 7	JGS376-8	3 - 1	JGX155-8	3 - 3
JGR737-8	3 - 10	JGS215-8	3 - 8	JGS378-8	3 - 5	JGX177-8	3 - 9
JGR738-8	3 - 9	JGS216-8	3 - 7	JGS379-8	3 - 1	JGX179-8	3 - 9
JGR743-8	3 - 13	JGS218-8	3 - 7	JGS383-8	3 - 8	JGX180-8	3 - 4
JGR760/25-8	4 - 1	JGS222-8	3 - 5	JGS384-8	3 - 2	JGX182-8	3 - 5
JGR778/6-8	3 - 5	JGS223-8	3 - 4, 3 - 7, 3 - 8	JGS386-8	3 - 10	JGX183-8	3 - 2
JGR780/9-8	3 - 5	JGS231-8	3 - 2	JGS404-8	3 - 6	JGX184-8	3 - 2, 3 - 13
JGS132-8	3 - 1, 3 - 3, 3 - 8	JGS232-8	3 - 2	JGS42	3 - 10	JGX191-8	3 - 2
JGS139-8	3 - 4	JGS235-8	3 - 1, 3 - 2	JGS59	3 - 9, 3 - 13	JGX218-8	3 - 5
JGS142-8	3 - 9, 3 - 10	JGS236-8	3 - 13	JGS654-8	3 - 1	JGZ142-8	3 - 3
JGS1453/3-8	3 - 10	JGS248-8	3 - 9	JGT159-8	3 - 2	JGZ151-8	3 - 13
JGS145-8	3 - 4	JGS249-8	3 - 9	JGU140-8	3 - 7	JGZ152-8	3 - 11
JGS146-8	3 - 4	JGS251-8	3 - 6	JGW130-8	3 - 11	JGZ164-8	3 - 12
JGS147-8	3 - 1, 3 - 3, 3 - 4, 3 - 7, 3 - 12	JGS255-8	3 - 11	JGW134-8	3 - 4	JGZ204-8	3 - 2
JGS148-8	3 - 4	JGS256-8	3 - 8, 3 - 10, 3 - 12	JGW135-8	3 - 4	JGZ205-8	3 - 2
JGS158-8	3 - 3	JGS263-8	3 - 9, 3 - 11, 3 - 13	JGW141-8	3 - 8	JGZ206-8	3 - 8
JGS160-8	3 - 3	JGS264-8	3 - 2	JGW142-8	3 - 8	JGZ219-8	3 - 7
JGS161-8	3 - 3	JGS273-8	3 - 8	JGW153-8	3 - 2	JGZ221-8	3 - 7
JGS163-8	3 - 3	JGS275-8	3 - 5	JGW166-8	3 - 10	JGZ223-8	3 - 3
JGS164-8	3 - 3	JGS276-8	3 - 6	JGW167-8	3 - 9	JGZ224-8	3 - 9
JGS166-8	3 - 3	JGS277-8	3 - 6	JGW172-8	3 - 5	JGZ225-8	3 - 12
JGS167-8	3 - 6, 3 - 12	JGS279-8	3 - 6	JGW173-8	3 - 5	JGZ246-8	3 - 5
JGS168-8	3 - 6	JGS280-8	3 - 6	JGW174-8	3 - 5	JS-549 397	3 - 12

114

Unterklassen-Ausstattung

Subclass parts

Composición de las subclases

子机型-设备

CSTMP

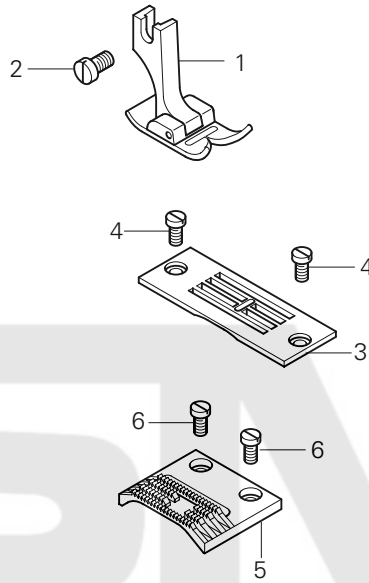

Pos.-Nr. Item No. N° de pos. 序号	Ausführung Model Tipo 款式	Stichlänge Stitch length Largo de puntada 针距	Überstichbreite Stitch width Ancho de zig-zag 曲折缝线迹宽度	Teile-Nr. Part No. N° de pieza 零件号
1	B♦	5,0	9,0	J GR465/4-8
2				J GS231-8
3	B♦	5,0	9,0	J GM156-8
4				J GS338-8

Pos.-Nr. Item No. N° de pos. 序号	Ausführung Model Tipo 款式	Stichlänge Stitch length Largo de puntada 针距	Überstichbreite Stitch width Ancho de zig-zag 曲折缝线迹宽度	Teile-Nr. Part No. N° de pieza 零件号
5	B♦	5,0	9,0	J GM160-8
6				J GS184-8

PFAFF



PFAFF Industrie Maschinen AG

Postfach 3020
D-67653 Kaiserslautern

Königstr. 154
D-67655 Kaiserslautern

Telefon: (0631) 200-0
Telefax: (0631) 17202
E-Mail: info@pfaff-industrial.com