

PARTS CATALOG

Cat. No. 8257

November, 1980.

R53 SERIES

MODELS: R53-01~89. DCR-942.



PEGASUS[®]



www.collegesewing.com

はじめに

このパーツカタログは、R53-01を基にR53シリーズミシンの構成部品を次の要領で編集しています。

機構別収録(2~37頁)

部品図解及び部品表を機構別に収録しています。

注1. 部品名称で「/」以降は、当該部品の補助説明です。

例1. ロッド/シタルーバー

従来の固有名称の一部(従来の名称:シタルーバーロッド)

例2. ネジ/C8

ネジの呼び径・ピッチ(当社のネジ分類表示方法にもとづく)

注2. 図解の枠内は表記の専用部品、またはセット部品を示します。

注3. 表中部品番号が「××××××」と表示されているのは、ゲージパーツです。

ゲージパーツ系列構成図・ゲージパーツ表(38~50頁)

これらの部品は、特定の形式にのみ使用されている部品で、系列構成図は38~47頁に、ゲージパーツ表は48~49頁に一括して記載しています。なお、専用部品は、50頁に記載しています。

部品番号インデックス(51~53頁)

51~53頁には、部品番号インデックスを付し、部品番号のみで、その図解、名称などが容易に引き出せます。

部品のご注文

部品のご注文の際は、必ず部品番号を明示して下さい。このパーツカタログは下記のミシンをもとに作成しています。

なお、部品番号、部品形状等が、予告なしに変更されることがありますので、あらかじめご承知おき下さい。

機種	機械番号	製造年月
R53	#5976946以後	1980年5月以降
R53-41,49	#5983667以後	1981年2月以降
DCR-942	#5943267以後	1980年8月以降

INTRODUCTION

This parts catalog has been arranged in the following manner on the basis of R53-01.

ARRANGEMENT BY MECHANISM(pages 2~37)

Each mechanism is arranged on facing pages, the first page containing the illustrations and the second page containing the data of the individual parts.

The machine type numbers in the illustrations indicate which machines the parts are used on.

Note 1: The words after the slash / and in brackets () in the part name are specifications and auxiliary explanations of the parts. EXAMPLE: BRACKET/BINDER

GAUGE PARTS CONSTRUCTION CHARTS/GAUGE PARTS LISTS

Gauge parts are used in some machine types and sewing gauges only. Pages 38-47 contain the gauge parts construction charts in order to know the illustrations and the combinations of the parts, and pages 48-49 contain the gauge parts lists to obtain the data at a glance.

PART NUMBER INDEX(pages 51~53)

A part number index is attached to the back of this catalog for convenience.

ORDERING PARTS

When placing orders for parts from this catalog, use ONLY THE PART NUMBER.

APPLICATION OF THIS CATALOG

This catalog covers the following machines and is applicable to your machine subject to change without notice.

MACHINE	MACHINE NO.	MANUFACTURING DATE
R53	#5976946 and after.	May, 1980 and after.
R53-41,49	#5983667 and after.	Feb., 1981 and after.
DCR-942	#5943267 and after.	Aug., 1980 and after.

目次

	頁
アーム・ベッド機構	2-3
カバー機構(1), (2)	4-7
主軸機構	8-9
針棒機構(1), (2), (3)	10-15
上ルーバー機構	16-17
下ルーバー機構	18-19
送り機構(1), (2), (3)	20-25
上下メス機構	26-27
押エ機構	28-29
給油機構	30-31
HR装置	32-33
アタッチメント及び特別注文品	34-35
付属品	36-37
ゲージパーツ系列構成図	38-47
ゲージパーツ表	48-49
専用部品表	50
部品番号インデックス	51-53
半沈床式据付付属品	54-55
糸立台	56-57

TABLE OF CONTENTS

	Page
MACHINE BED FRAME	2-3
COVERS (1), (2)	4-7
CRANKSHAFT DRIVE MECHANISM	8-9
NEEDLE DRIVE MECHANISM (1), (2), (3)	10-15
UPPER LOOPER DRIVE MECHANISM	16-17
LOWER LOOPER DRIVE MECHANISM	18-19
FEED MECHANISM (1), (2), (3)	20-25
UPPER AND LOWER KNIFE MECHANISM	26-27
PRESSER FOOT MECHANISM	28-29
LUBRICATING MECHANISM	30-31
HR DEVICE (Needle and Thread Lubricators)	32-33
ATTACHMENTS AND SPECIAL ORDER PARTS	34-35
ACCESSORIES	36-37
GAUGE PARTS CONSTRUCTION CHARTS	38-47
GAUGE PARTS LIST	48-49
SPECIFIC PARTS	50
PART NUMBER INDEX	51-53
PARTS FOR SEMI-SUBMERGED INSTALLATION	54-55
THREAD STAND	56-57

WWW

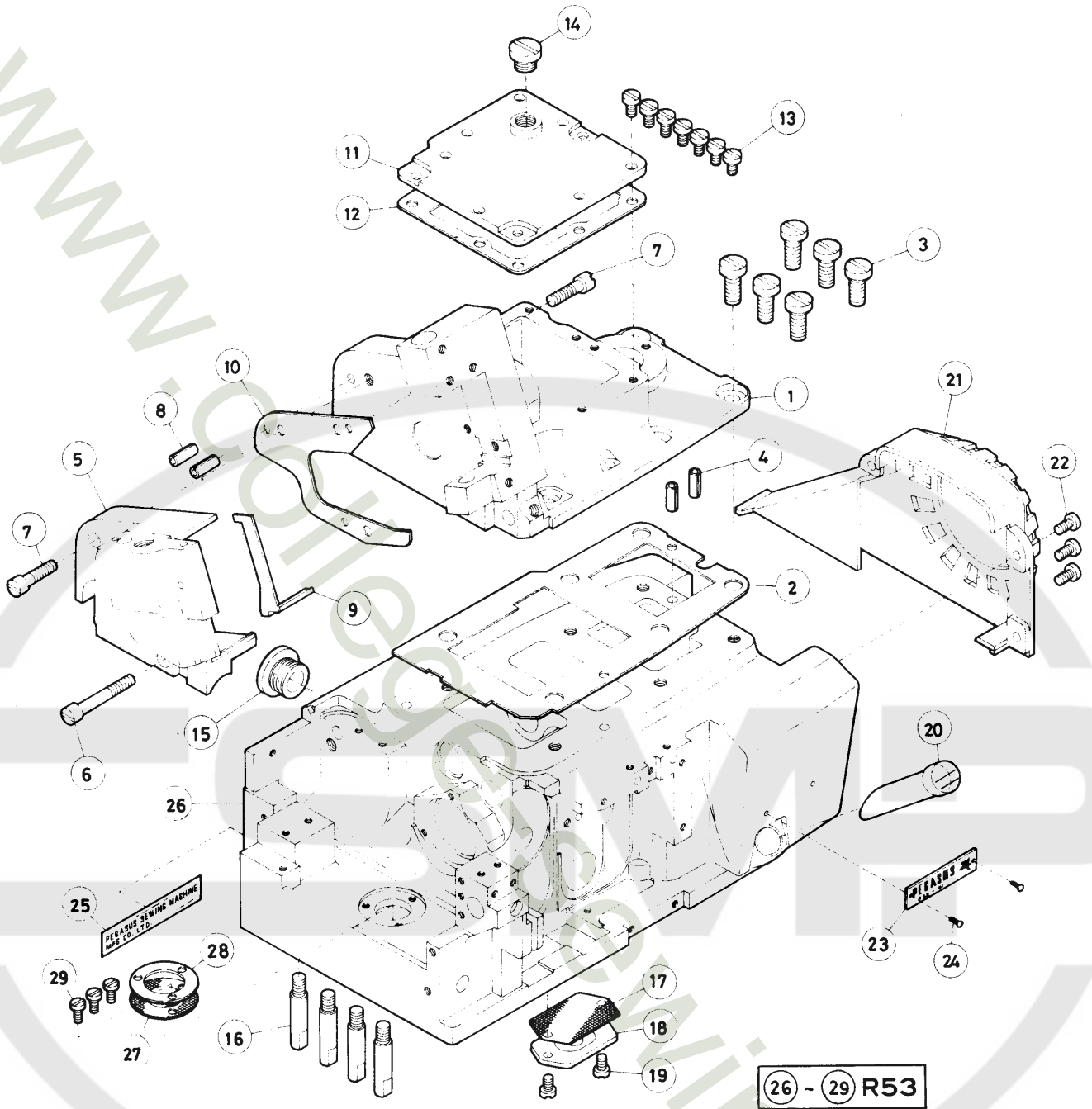

R53-41, 49

DCR-942

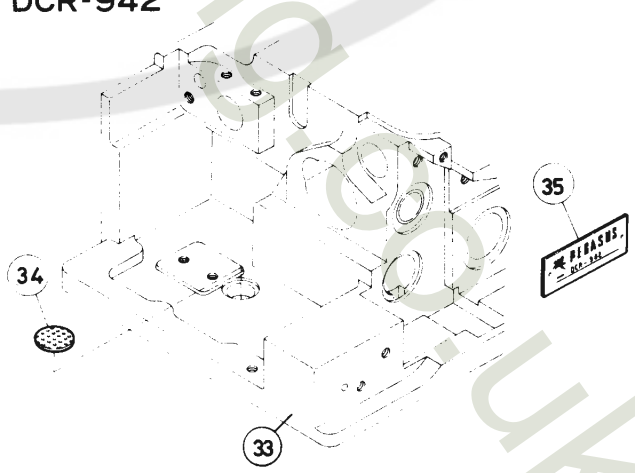
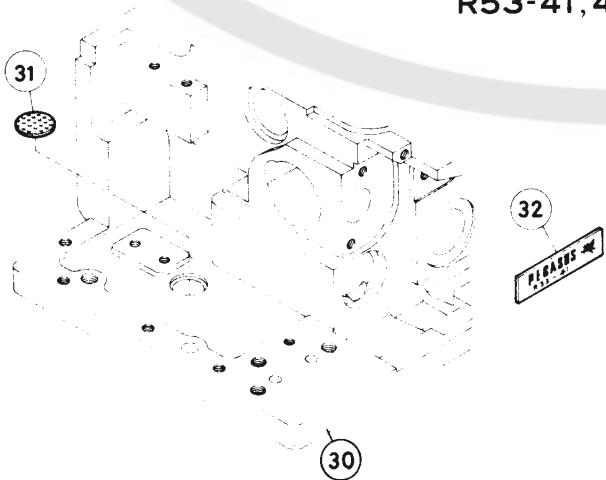

アーム・ベッド機構

MACHINE BED FRAME

REF. NO.	PART NO.	メイショウ	NAME	QT.
1	205689-FD	ア-ム(A)	MACHINE ARM (RIGHT)	1
2	202716	カ-ステツト	GASKET	1
3	5078	ヒラネシ- /C11	SCREW	6
4	201002	スフ-リング-ピ-ン	PIN	2
5	205690-FD	ア-ム(B)	MACHINE ARM (LEFT)	1
6	5237	ヒラネシ- /C8	SCREW	1
7	5163	ヒラネシ- /C8	SCREW	2
8	201002	スフ-リング-ピ-ン	PIN	2
9	205691	ア-ムラヨケ	OIL SHIELD	1
10	205692	カ-ステツト	GASKET	1
11	202648C	ア-ム カワイタ	COVER	1
12	202649A	カ-ステツト	GASKET	1
13	5117	ヒラネシ- /C5	SCREW	7
14	5198	ヒラネシ- /C14	SCREW	1
15	202687	セ-ン	SCREW	1
16	202354	ハ-ツツ- アシ ピ-ン	PIN	4
17	202662	カナアミ(B)	FILTER SCREEN	1
18	202663D	カナイタ(B)	PLATE	1
19	1175-2	ヒラネシ- /C4	SCREW	2
20	201330	オイル ケ-ジ-	OIL LEVEL SIGHT GAUGE	1
21	205693-FD	ハ-ルトカハ-	BELT GUARD	1
22	5117	ヒラネシ- /C5	SCREW	3
23	212279	ケイシキハ-	TYPE PLATE	1
24	210679	トメピ-ン	TYPE PLATE PIN	2
25	202526	キメイハ-	NAME PLATE	1
26	205828	ハ-ツツ-	MACHINE BED	1
27	201004	カナアミ(A)	OIL FILTER SCREEN	1
28	205708	カナイタ(A)	OIL FILTER SCREEN PLATE	1
29	1189	ヒラネシ- /C4	SCREW	3
30	205829	ハ-ツツ-	MACHINE BED	1
31	202355	カナアミ(A)	FILTER SCREEN	1
32	212279	ケイシキハ-	TYPE PLATE	1
33	205830	ハ-ツツ-	MACHINE BED	1
34	202355	カナアミ(A)	FILTER SCREEN	1
35	212279	ケイシキハ-	TYPE PLATE	1

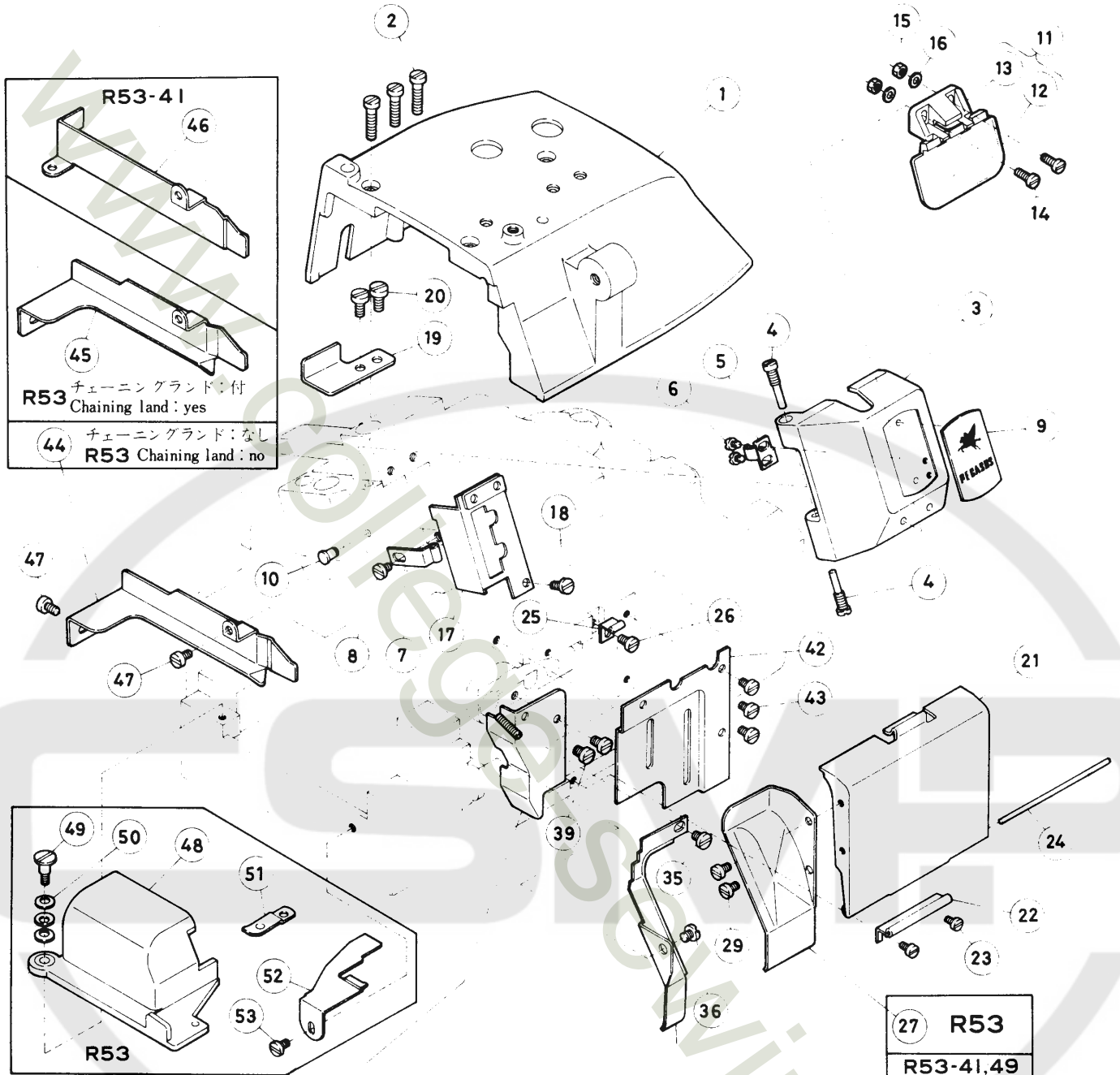

R53-41

46

45

R53 チェーニングランド：付
Chaining land : yes

44 チェーニングランド：なし
R53 Chaining land : no

R53

49 50 48 51 52 53

R53

R53・1本針
1-needle R53

37

40 41 38

R53-41,49
DCR-942

R53・2本針
2-needle R53

R53・1本針
1-needle R53
HR装置無

30

34 33 32 31

R53

R53-41,49

28

DCR-942

R53-41,49 **R53・2本針** **R53・2本針** **R53・1本針**
DCR-942 **HR装置付** **HR装置無** **HR装置付**
 2-needle R53 with HR Device 2-needle R53 without HR Device 1-needle R53 with HR Device

カバー機構(1)

COVERS(1)

REF. NO.	PART NO.	メキシコ	NAME	QT.
1	202686B-HD	うつかハ-	TOP COVER	1
2	5095	ヒラネシ	SCREW	3
3	205694	ハリホウカハ-	NEEDLE BAR COVER	1
4	202653	ヒンツキネシ	HINGE PIN	2
5	202689	イタハネ(A)	LOCK SPRING	1
6	1234	ヒラネシ/C4	SCREW	2
7	201404	イタハネ(B)	LATCH	1
8	4009-1	ヒラネシ/C5	SCREW	1
9	208724	メイハン	NAME PLATE	1
10	198192	ホウシンゴム	CUSHION RUBBER	1
11	208747	アイカート(クミ)	EYE GUARD COMPLETE	1
12	205685	アイカート	EYE GUARD	1
13	208744	フウケツト	EYE GUARD BRACKET COMPLETE	1
14	1175-3	ヒラネシ/C3	SCREW	2
15	3091	ワツカクナツト/C3	NUT	2
16	137906	サカカネ	WASHER	2
17	208430	メンイタ(クミ)	FACE PLATE	1
18	4009-1	ヒラネシ/C5	SCREW	1
19	205767	ウシロカハ-	REAR COVER	1
20	1206	ヒラネシ/C4	SCREW	2
21	201200-FD	マエカハ-(ミキ)	FRONT COVER (RIGHT)	1
22	201201	ヒンシ	HINGE	1
23	1216	ヒラネシ/C4	SCREW	2
24	201202	ハコウヒン	PIN	1
25	201203	イタハネ	LOCK SPRING	1
26	1216	ヒラネシ/C4	SCREW	1
27	202660	マエカハ-(ナカ)	CHIP GUARD	1
28	205399	マエカハ-(ナカ)	FRONT COVER EXTENSION	1
29	2921	ヒラネシ/C3	SCREW	2
30	202680	マエカハ-(ヒタリ)	CHIP GUARD	1
31	202750	マエカハ-(ヒタリ)	CHIP GUARD	1
32	202755	マエカハ-(ヒタリ)	CHIP GUARD	1
33	202741	マエカハ-(ヒタリ)	CHIP GUARD	1
34	205398	マエカハ-(ヒタリ)	CHIP GUARD	1
35	1216	ヒラネシ/C4	SCREW	1
36	2905	ヒラネシ/C5	SCREW	1
37	202937	ウフルハ-タマイカハ-	COVER	1
38	205296	ウフルハ-タマイカハ-	COVER	1
39	1216	ヒラネシ/C4	SCREW	2
40	205400	ウフルハ-タマイカハ-	UPPER LOOPER COVER	1
41	1216	ヒラネシ/C4	SCREW	1
42	202942	イトミチトリツケイタ/ルハ-	THREAD PLATE	1
43	1216	ヒラネシ/C4	SCREW	3
44	202651A	コトヨク	FABRIC GUARD	1
45	202796	コトヨク	FABRIC GUARD	1
46	205518	コトヨク	FABRIC GUARD	1
47	1216	ヒラネシ/C4	SCREW	2
48	205714	オクリタマイカハ-	FEED BAR COVER	1
49	205544	タツキネシ	SCREW	1
50	201191	ハネサカカネ	WASHER	3
51	205545	イタハネ	FLAT SPRING	1
52	205859	ストッパ-	STOPPER	1
53	1216	ヒラネシ/C4	SCREW	1

R53

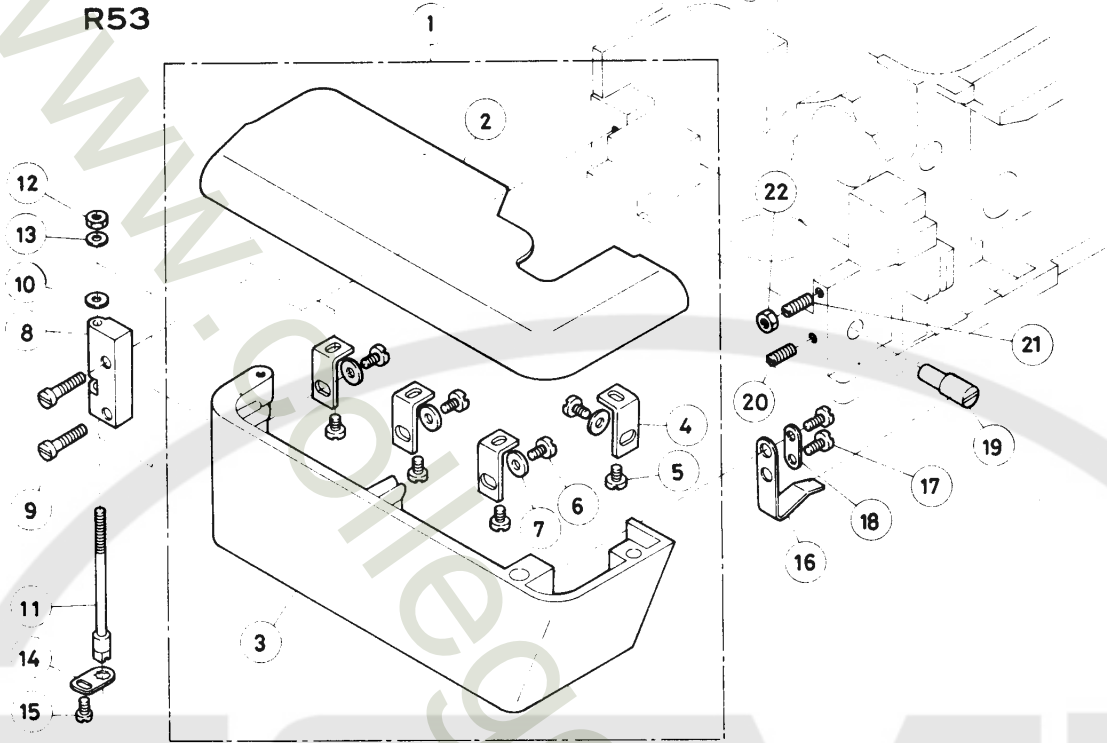

R53-41, 49

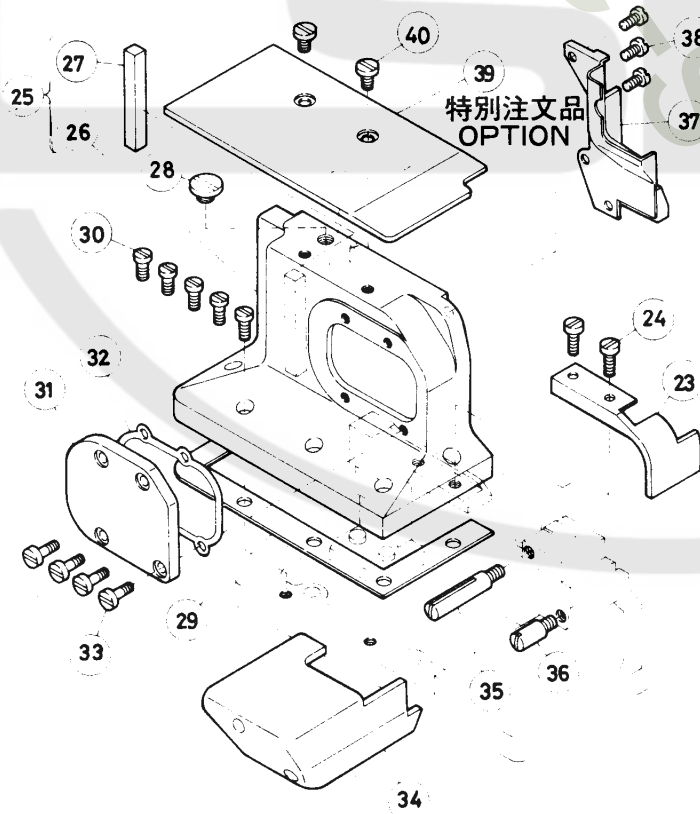

DCR-942

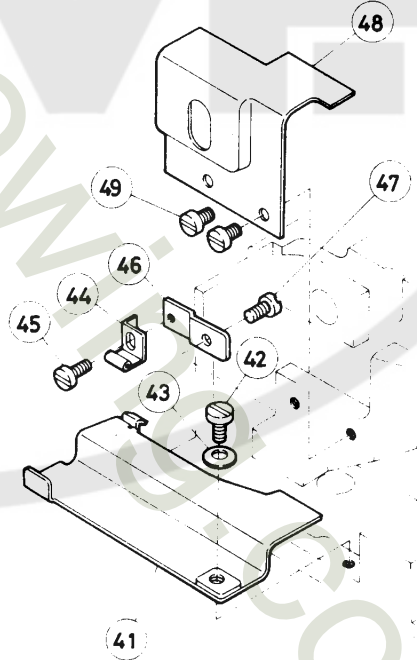

カバー機構(2)

COVERS(2)

REF. NO.	PART NO.	メイシヨウ	NAME	QT.
1	202466	クロスプレート(クミ)	CLOTH PLATE COMPLETE	1
2	201181C	クロスプレート(ウI)	CLOTH PLATE	1
3	202467-FD	ヨコカバー	SIDE COVER	1
4	201184	ブラケット	BRACKET	4
5	1216	ヒラネシメ/C4	SCREW	4
6	1202	ヒラネシメ/C4	SCREW	4
7	201185	サカネ	WASHER	4
8	200159A	ヒンジ	HINGE	1
9	5095	ヒラネシメ/C5	SCREW	2
10	200183	カラ	THRUST WASHER	1
11	201221A	ヒンツキネシメ	HINGE PIN	1
12	5099	ワッカクナツ/C3	NUT	1
13	200821	サカネ	WASHER	1
14	202865	マクリツメ	STOPPER	1
15	5293	ヒラネシメ/C4	SCREW	1
16	201186	イタハネ	FLAT SPRING	1
17	1216	ヒラネシメ/C4	SCREW	2
18	200162A	サカネ	WASHER	1
19	200163A	タンツキヒオン	LATCH PIN	1
20	1435	トメネシメ/C5	SCREW	1
21	1435	トメネシメ/C5	SCREW	1
22	3044	ワッカクナツ/C5	NUT	1
23	205382	オクリエキセン カバー	FEED ECCENTRIC COVER	1
24	1216	ヒラネシメ/C4	SCREW	2
25	205387	オクリタマイカバー(クミ)	FEED BAR COVER COMPLETE	1
26	205388-FD	オクリタマイ カバー	FEED BAR COVER	1
27	205389	アブラヨケ	OIL SHIELD	1
28	5434	ヒラネシメ/C10	SCREW	2
29	205390	ガスケット	GASKET	1
30	2213-1	ヒラネシメ/C5	SCREW	5
31	205391	フタ/オクリエキセン	COVER PLATE/FEED ECCENTRIC	1
32	205392	リング	O RING	1
33	1326	ヒラネシメ/C4	SCREW	4
34	205393	ツツカバー	LOOPER COVER	1
35	205394	ヒンツキネシメ/チヨウ	PIN (LONG)	1
36	205395	ヒンツキネシメ/タン	PIN (SHORT)	1
37	205383	シタルハカカバー(クミ)	LOWER LOOPER COVER	1
38	5142	ヒラネシメ/C4	SCREW	3
39	205396	ヒラカバー	CLOTH PLATE	1
40	4009-1	ヒラネシメ/C5	SCREW	2
41	205836-FD	アブラヨケ	OIL SHIELD	1
42	5422	タンツキネシメ/C5	SCREW	1
43	211301	サラハネ	SPRING WASHER	1
44	205840	イタハネ	FLAT SPRING	1
45	1234	ヒラネシメ/C4	SCREW	1
46	205841	ブラケット	BRACKET	1
47	5117	ヒラネシメ/C5	SCREW	1
48	202439-FD	オクリタマイ カバー	FEED BAR COVER	1
49	5117	ヒラネシメ/C5	SCREW	2

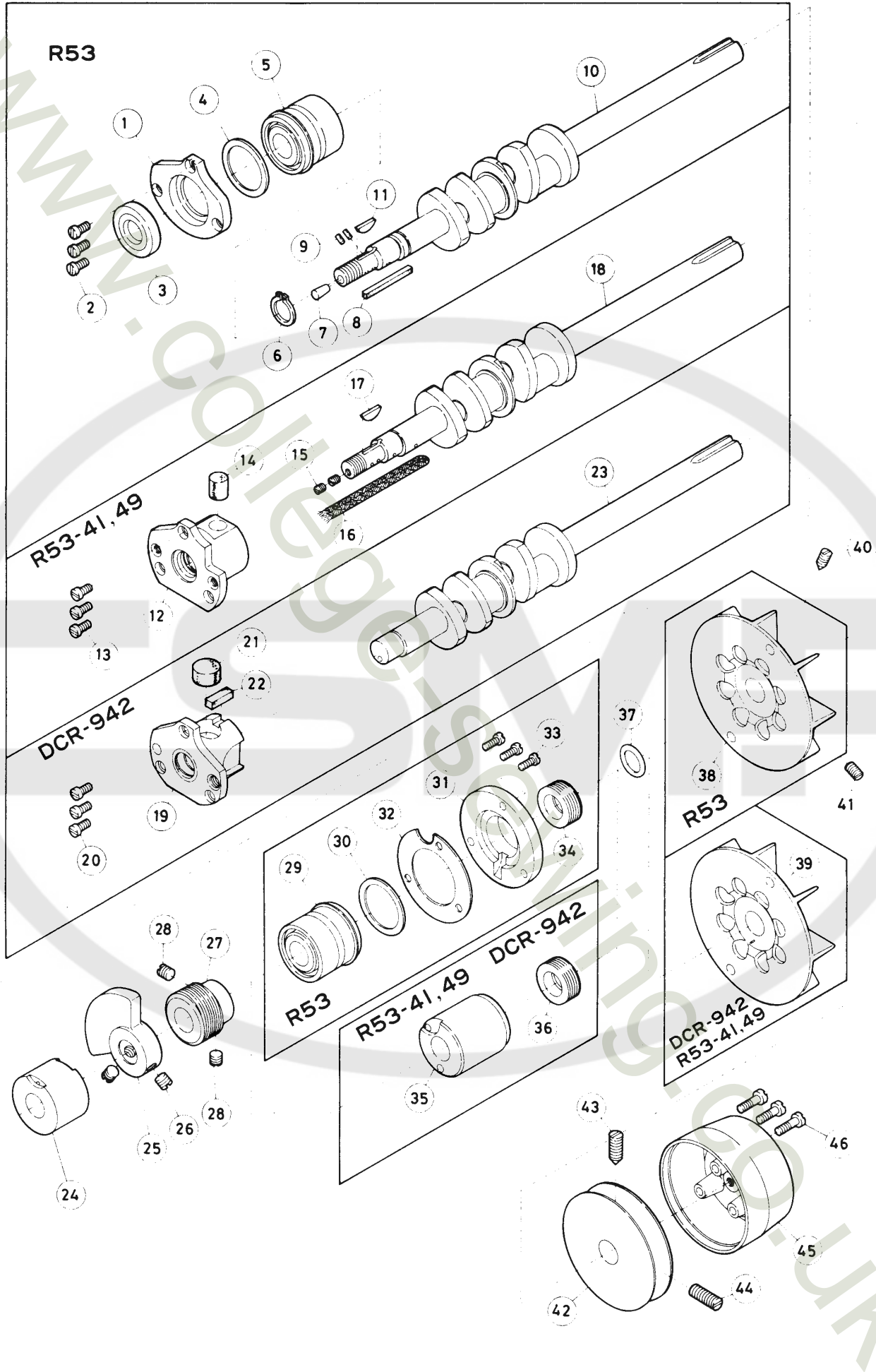

主軸機構

CRANKSHAFT MECHANISM

REF. NO.	PART NO.	メイシヨウ	NAME	QT.
1	202940	オサエカネ	RETAINER	1
2	1175-2	ヒラネシム/C4	SCREW	3
3	202908	オイルシール	OIL SEAL	1
4	202907	カステット	PACKING	1
5	202902	ニートル ヰアリング	NEEDLE BEARING	1
6	202901	トメフ	RETAINING RING	1
7	202903	セン	PLUG	1
8	202990	キョウフイルト	OIL FELT	1
9	202081	キョウフイルト	OIL FELT	2
10	205261	クランクシク	CRANKSHAFT	1
11	201009	キー	KEY	1
12	205402A	フツシユ(ヒタリ)	BUSHING (LEFT)	1
13	1175-2	ヒラネシム/C4	SCREW	3
14	205448	キョウフイルト	OIL FELT	1
15	1892	トメネシム/C3	SCREW	2
16	202175	キョウヒモ	OIL WICK	1
17	201009	キー	KEY	1
18	205401	クランクシク	CRANKSHAFT	1
19	205846	フツシユ(ヒタリ)	BUSHING (LEFT)	1
20	1175-2	ヒラネシム/C4	SCREW	3
21	204273	キョウフイルト(タイ)	OIL FELT	1
22	202864	キョウフイルト(シヨウ)	OIL FELT	1
23	202730	クランクシク	CRANKSHAFT	1
24	201212D	フツシユ(チウカン)	BUSHING (CENTER)	1
25	201010A	カウンター ウイト	COUNTERWEIGHT	1
26	5060	トメネシム/C8	SCREW	2
27	201298	ウオーム	WORM	1
28	5060	トメネシム/C8	SCREW	2
29	202902	ニートル ヰアリング	NEEDLE BEARING	1
30	205526	カステット	OIL SEAL RING	1
31	205700	オサエカネ	RETAINER	1
32	202905	カステット	GASKET	1
33	1175-2	ヒラネシム/C4	SCREW	3
34	205701	アフラキリ	OIL SHIELD	1
35	205720	フツシユ(ミキ)	BUSHING (RIGHT)	1
36	205713	アフラキリ	OIL SHIELD	1
37	208272	オリング	O RING	1
38	205698	ファン	FAN	1
39	205711	ファン	FAN	1
40	5149A	トメネシム/C5	SCREW	1
41	1458	トメネシム/C5	SCREW	1
42	201017A	プーリー	PULLEY	1
43	5080	トメネシム/C9	SCREW	1
44	5081	トメネシム/C9	SCREW	1
45	205471	フタ	PULLEY CAP	1
46	5010	ヒラネシム/C4	SCREW	3

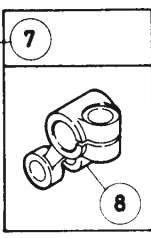
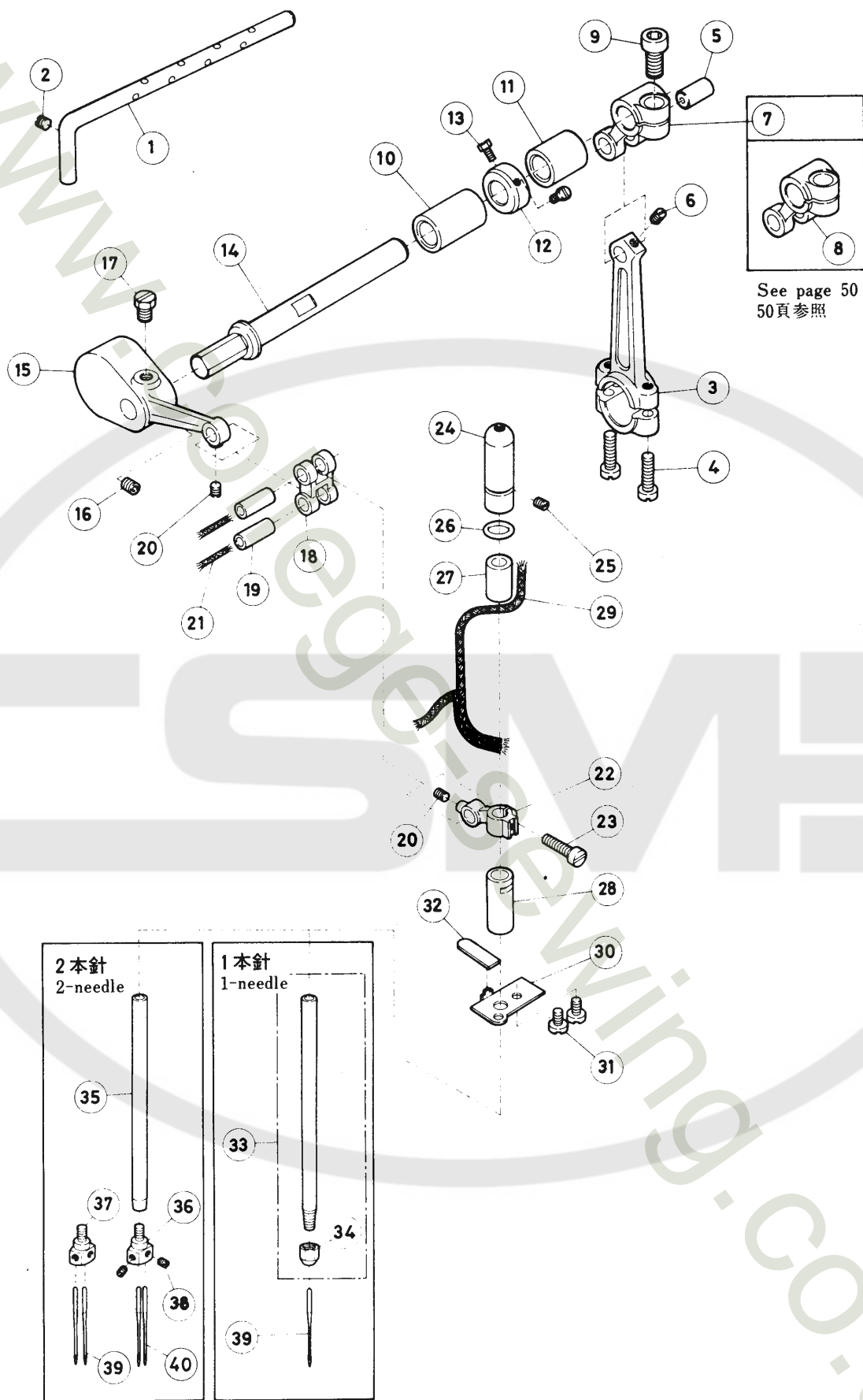

See page 50
50頁参照

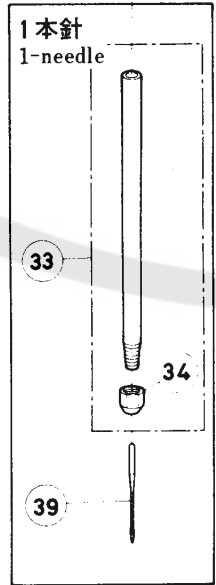
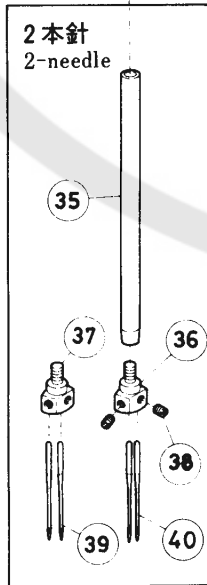

針棒機構(1)

NEEDLE DRIVE MECHANISM(1)

REF. NO.	PART NO.	メイショウ	NAME	QT.
1	202999	イトミチホウ	THREAD GUIDE	1
2	5185	トメネシ ^メ /C8	SCREW	1
3	202605	ロツ ^メ	CONNECTION	1
4	5233	ヒラネシ ^メ /C7	SCREW	2
5	205495	エイコウヒ ^{オン}	PIN	1
6	5234	トメネシ ^メ /C7	SCREW	1
7	201360B	クランク(ウシロ)	CRANK (REAR)	1
8	201441B	クランク(ウシロ)	CRANK (REAR)	1
9	5381	ヒラネシ ^メ /C10	SCREW	1
10	201356A	フツシ ^メ (ヒタマリ)	BUSHING (LEFT)	1
11	201115A	フツシ ^メ (ミキ ^メ)	BUSHING (RIGHT)	1
12	201117	カラ ^メ	COLLAR	1
13	5328	ヒラネシ ^メ /C4	SCREW	2
14	202606	シャク/ハリホ ^ウ	SHAFT	1
15	208424	クランク(マイ)/ハリホ ^ウ	NEEDLE BAR DRIVE CRANK	1
16	5312	トメネシ ^メ /C10	SCREW	1
17	2022-4	ロツカクネシ ^メ /C10	SCREW	1
18	208425	リンク	LINK	1
19	200654	エイコウヒ ^{オン}	PIN	2
20	5292	トメネシ ^メ /C3	SCREW	2
21	202176	キユウヒモ	OIL WICK	2
22	208427	ハリホ ^ウ タ ^キ	NEEDLE BAR CLAMP	1
23	1170-3	ヒラネシ ^メ /C4	SCREW	1
24	208621	キャツ ^フ	CAP	1
25	1457	トメネシ ^メ /C5	SCREW	1
26	200030	リング ^メ	RUBBER RING	1
27	204625A	フツシ ^メ (ウイ)	BUSHING (UPPER)	1
28	204627	フツシ ^メ (シタ)	BUSHING (LOWER)	1
29	212186	キユウヒモ	OIL WICK	2
30	205697	コ ^メ ミヨ ^ケ	DUST GUARD	1
31	5053	ヒラネシ ^メ /C4	SCREW	2
32	208617	フェルト	OIL RELEASE FELT	1
33	204623	ハリホ ^ウ (クミ)	NEEDLE BAR COMPLETE	1
34	3119	ハリト ^メ ナツト	NUT	1
35	208903	シャク/ハリホ ^ウ	NEEDLE BAR	1
36	208904	ハリト ^メ /1.5MM	NEEDLE HOLDER/1.5MM	1
37	208905	ハリト ^メ /2MM	NEEDLE HOLDER/2MM	1
38	5292	トメネシ ^メ /C3	SCREW	2
39	DCX1	ハリ	NEEDLE	
40	DCX3	ハリ	NEEDLE	

R53

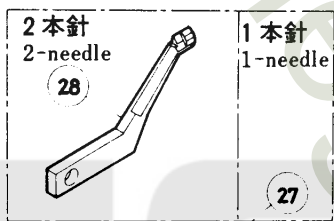
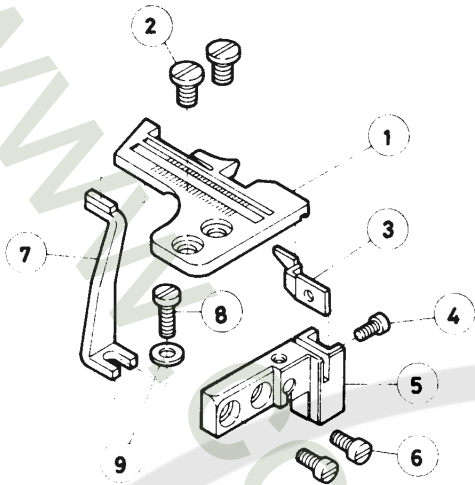

R53
R53-41,
49

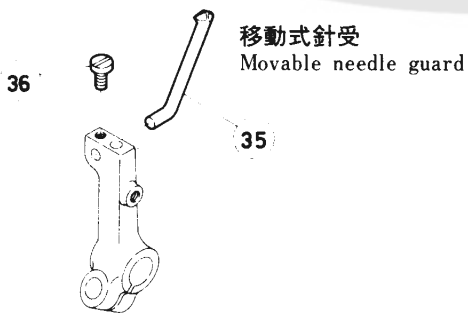
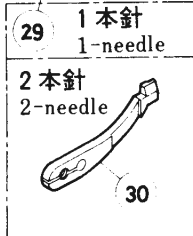
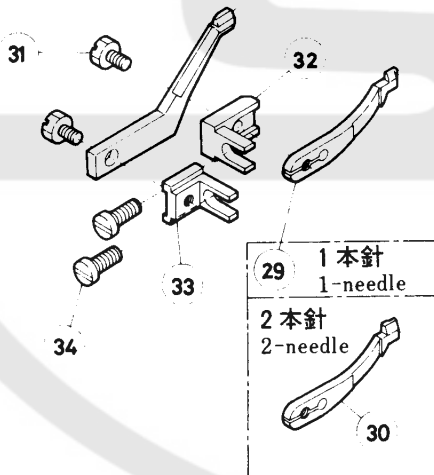

R53-41, 49

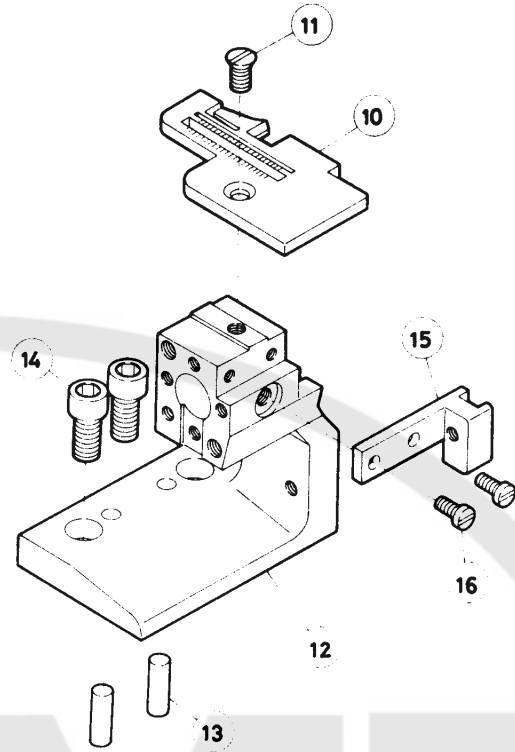

DCR-942

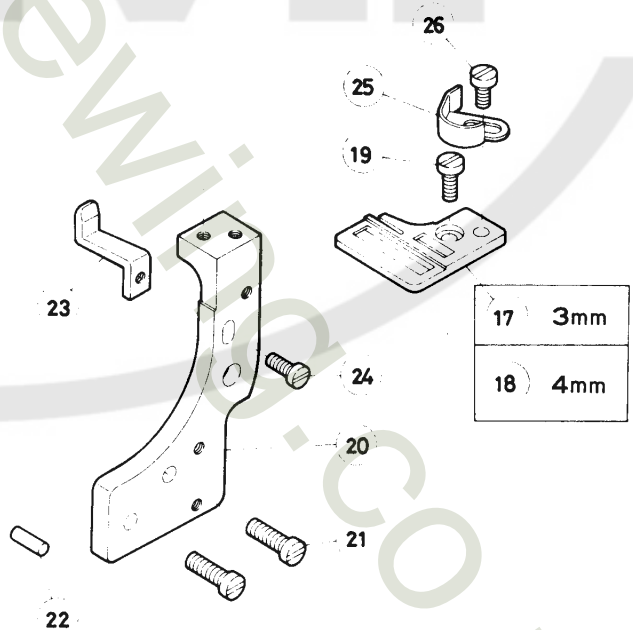

針棒機構(2)

NEEDLE DRIVE MECHANISM(2)

REF. NO.	PART NO.	メイシヨウ	NAME	QT.
1	XXXXXX	ハリイタ	NEEDLE PLATE	1
2	4009-1HC	ヒラネシ ^レ /C5	SCREW	2
3	201034A	キ-	KEY	1
4	5053	ヒラネシ ^レ /C4	SCREW	1
5	201092A	ブラケット	BRACKET	1
6	1175-2	ヒラネシ ^レ /C4	SCREW	2
7	205479	シシ ^レ イタ	SUPPORT	1
8	1175-3	ヒラネシ ^レ /C4	SCREW	1
9	201252	ハネサ ^レ カ ^レ ネ	WASHER	1
10	XXXXXX	ハリイタ	NEEDLE PLATE	1
11	1732	サ ^レ ネシ ^レ /C5	SCREW	1
12	205406	ブラケット	BRACKET	1
13	206215	エイコウ ^レ ピ ^レ ン	PIN	2
14	5381	ヒラネシ ^レ /C10	SCREW	2
15	205407	ブラケット	BRACKET	1
16	1175-2	ヒラネシ ^レ /C4	SCREW	2
17	202403	ハリイタ/3MM	NEEDLE PLATE	1
18	205832	ハリイタ/4MM	NEEDLE PLATE/4MM	1
19	5328-HC	ヒラネシ ^レ /C4	SCREW	1
20	202404	ブラケット	BRACKET	1
21	1156	ヒラネシ ^レ /C5	SCREW	2
22	202405	エイコウ ^レ ピ ^レ ン	PIN	1
23	202490	ハリウケ	NEEDLE GUARD	1
24	1175-2	ヒラネシ ^レ /C4	SCREW	1
25	202437	シ ^レ ヨウキ ^レ	GUIDE	1
26	1202	ヒラネシ ^レ /C4	SCREW	1
27	202474A	ハリウケ(ウシロ)	NEEDLE GUARD (REAR)	1
28	202688	ハリウケ(ウシロ)	NEEDLE GUARD (REAR)	1
29	201453B	ハリウケ(マエ)	NEEDLE GUARD (FRONT)	1
30	201454B	ハリウケ(マエ)	NEEDLE GUARD (FRONT)	1
31	5364	ワツカク ^レ ネシ ^レ /C4	SCREW	2
32	202491	ブラケット(ウシロ)	BRACKET	1
33	202724	ブラケット(マエ)	BRACKET	1
34	1175-3	ヒラネシ ^レ /C4	SCREW	2
35	202749	イト ^レ ウシキハリウケ	MOVABLE NEEDLE GUARD	1
36	1186	ヒラネシ ^レ /C3	SCREW	1

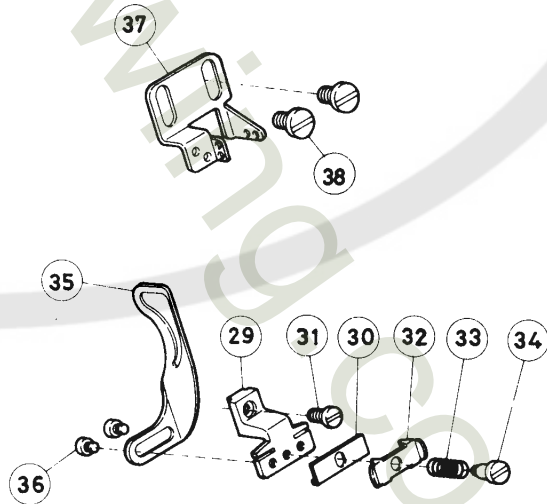
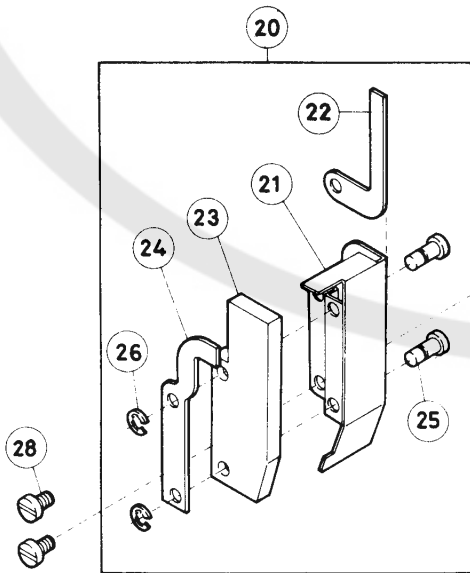
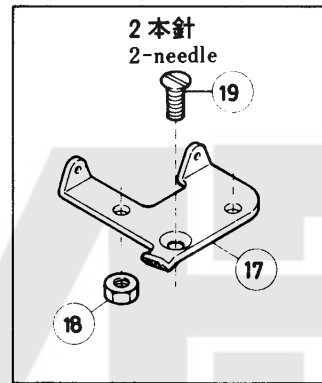
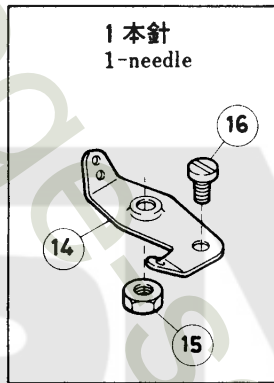
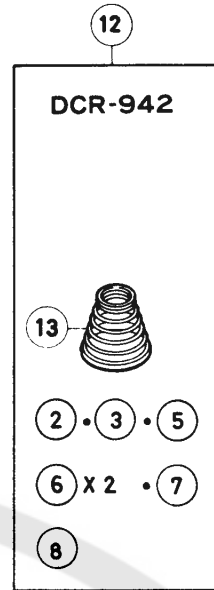
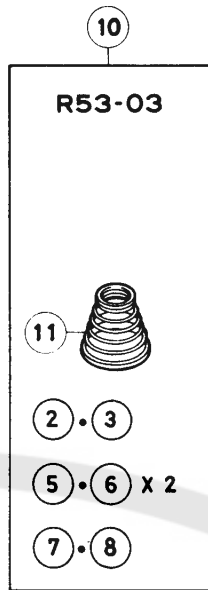
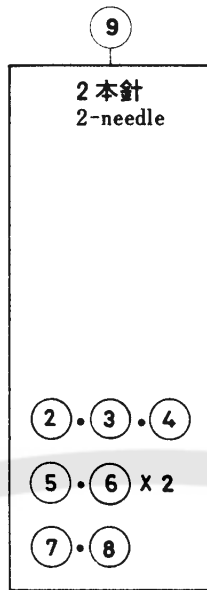
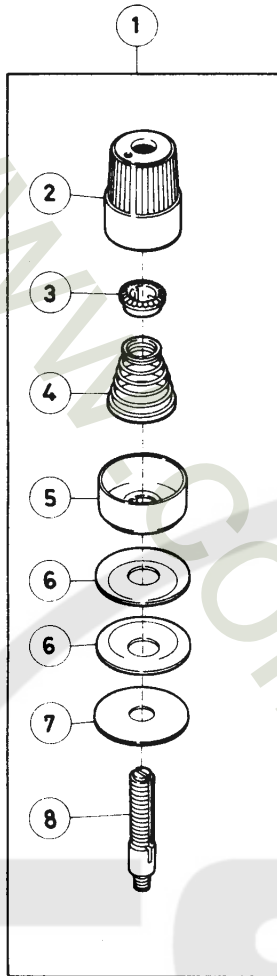

REF. NO.	機種	MACHINE	QT.
①	R53・1本針 (R53-03は除く) R53-41	1-needle R53 except R53-03. R53-41	1
⑨	R53-03	R53-03	2
⑩	R53・2本針	2-needle R53	1
⑫	DCR-942	DCR-942	1

針棒機構(3)

NEEDLE DRIVE MECHANISM(3)

REF. NO.	PART NO.	メイシヨウ	NAME	QT.
1	208488	イトチヨウシ(クミ)	THREAD TENSION COMPLETE	1
2	208447	チヨウシナツト	POST NUT	1
3	208448	トメハ ^o イフ ^o	SPRING BUSHING	1
4	201037	アツシユクハ ^o ネ/キヨウ	TENSION SPRING (HEAVY)	1
5	208450	ウケサ ^o ラ	CAP	1
6	201482	チヨウシサ ^o ラ	DISC	2
7	208449	フェルト	FELT	1
8	5082A	チヨウシホ ^o ウ	POST	1
9	208488	イシチヨウシ(クミ)	THREAD TENSION COMPLETE	1
10	208489	イトチヨウシ(クミ)	THREAD TENSION COMPLETE	1
11	201086	アツシユクハ ^o ネ/チユウ	TENSION SPRING (MEDIUM)	1
12	208490	イトチヨウシ(クミ)	THREAD TENSION COMPLETE	1
13	201068	アツシユクハ ^o ネ/シ ^o ヤク	TENSION SPRING (LIGHT)	1
14	205770	チヨウシタ ^o イ	GUIDE	1
15	5137	ロツカクナツト/C5	NUT	1
16	4009-1	ヒラネシ ^o /C5	SCREW	1
17	201243A	チヨウシタ ^o イ	BRACKET	1
18	5137	ロツカクナツト/C5	NUT	1
19	1732	サラネシ ^o /C5	SCREW	1
20	208568	ハリホ ^o ウリンクカハ ^o -(クミ)	COVER COMPLETE/NEEDLE BAR LINK	1
21	208560	ハリホ ^o ウリンクカハ ^o -	COVER	1
22	208561	フェルト	OIL FELT	1
23	208562	キユウシフェルト	OIL FELT	1
24	208563	トメイタ	OIL FELT PLATE	1
25	208713	タ ^o ンツキヒ ^o ン	PIN	2
26	200555	トメフ	RETAINING RING	2
27	205703	サ ^o カ ^o ネ	WASHER	1
28	5117	ヒラネシ ^o /C5	SCREW	2
29	202705A	コチヨウシ タ ^o イ	RETAINER BRACKET	1
30	202495	アテカ ^o ネ	GUIDE	1
31	5359	ヒラネシ ^o /C3	SCREW	1
32	200041	コチヨウシ サ ^o ラ	GUIDE	1
33	200205	アツシユクハ ^o ネ	SPRING	1
34	9070-2	タ ^o ンツキネシ ^o	SCREW	1
35	202706A	ハリイト チヨウセツキ	THREAD TAKEUP	1
36	5299	ヒラネシ ^o /C3	SCREW	2
37	208777	イトミチ(A)/ハリ	NEEDLE THREAD GUIDE	1
38	4009-1	ヒラネシ ^o /C5	SCREW	1

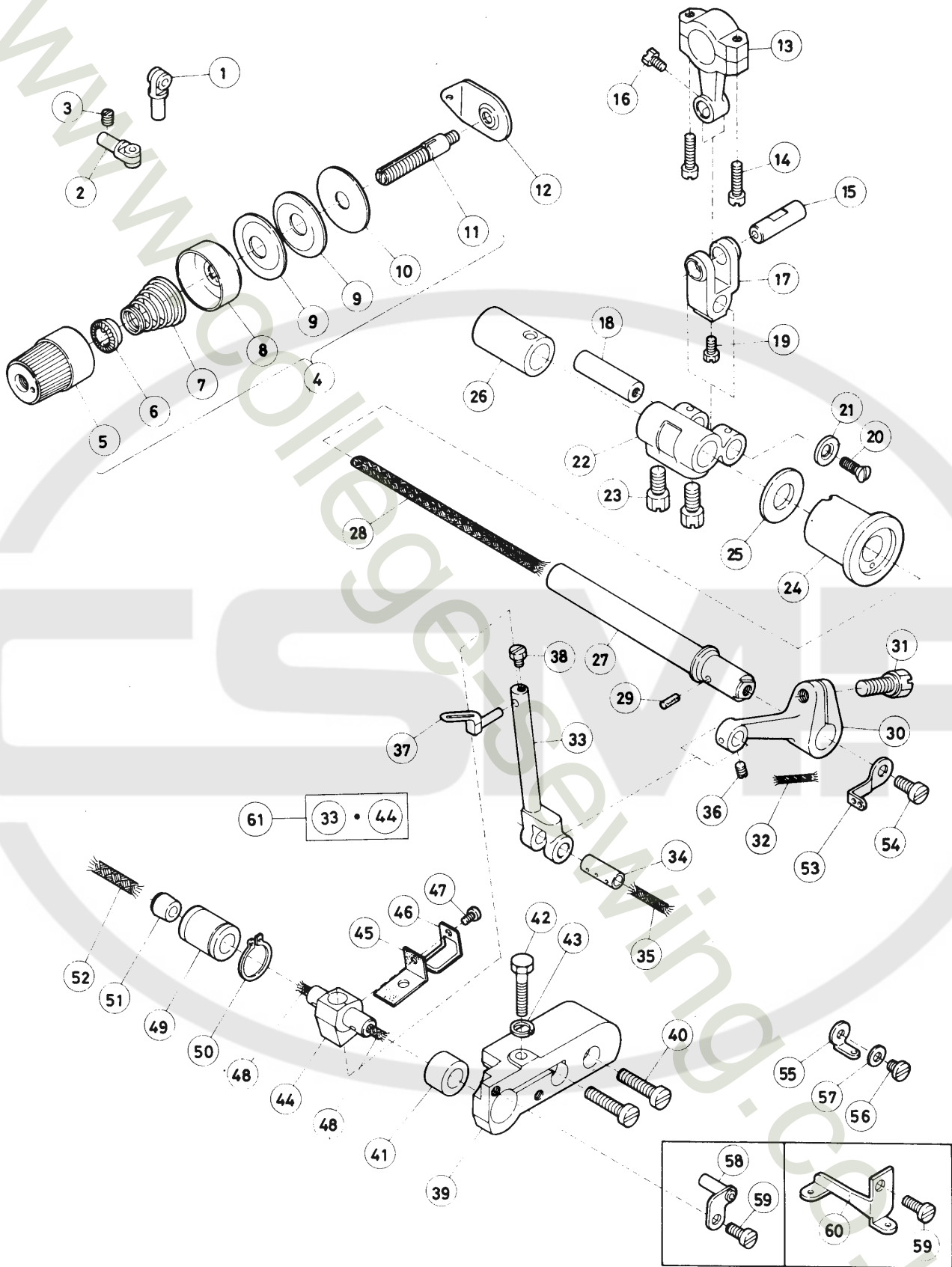

R53-41,49
DCR-942

移動式針受用
For movable
needle guard

上ルーパー機構

UPPER LOOPER DRIVE MECHANISM

REF. NO.	PART NO. フ ハ ン	メイシヨウ	NAME	QT.
1	201048A	イトミチ	THREAD EYELET	1
2	201048A	イトミチ	THREAD EYELET	1
3	1459	トメネシ/C4	SCREW	1
4	208490	イトチヨウシ(クミ)/ウフル-ハ°-	THREAD TENSION COMPLETE	1
5	208447	チヨウシナツト	TENSION NUT	1
6	208448	トメハ°イフ°	SPRING BUSHING	1
7	201068	アツシユクハ°ネ/シ°ヤク	TENSION SPRING (LIGHT)	1
8	208450	ウケサ°ヲ	CAP	1
9	201482	チヨウシサ°ヲ	DISC	2
10	208449	フェルト	FELT	1
11	5082A	チヨウシホ°ウ	POST	1
12	202849	チヨウシタイ	TENSION GUIDE PLATE	1
13	202619A	ロツク/ウフル-ハ°-	CONNECTION	1
14	5002	ヒラネシ/C5	SCREW	2
15	205495	ハイコウピン	PIN	1
16	5084	ロツカクネシ/C5	SCREW	1
17	202709A	レンゲツカン	LINK	1
18	202712A	ハイコウピン	PIN	1
19	5084	ロツカクネシ/C5	SCREW	1
20	5373	サラネシ/C4	SCREW	1
21	202757A	サ°カ°ネ	WASHER	1
22	202710A	クランク(ウシロ)/ウフル-ハ°-	CRANK	1
23	2022-4	ロツカクネシ/C10	SCREW	2
24	202623A	フ°ツシ(マエ)	BUSHING	1
25	202922	サ°カ°ネ	WASHER	1
26	210125	フ°ツシ(ウシロ)	BUSHING (REAR)	1
27	202622B	シャク/ウフル-ハ°-	SHAFT	1
28	202177	キユウジヒモ	OIL WICK	1
29	202081	キユウジフエルト	OIL WICK	1
30	202626A	クランク(マエ)/ウフル-ハ°-	CRANKSHAFT	1
31	5219	ロツカクネシ/C10	SCREW	1
32	202176	キユウジヒモ	OIL WICK	1
33	202827	ウフル-ハ°-タイ	UPPER LOOPER HOLDER	1
34	202625	ハイコウピン	PIN	1
35	202176	キユウジヒモ	OIL WICK	1
36	5146	トメネシ/C4	SCREW	1
37	XXXXXX	ウフル-ハ°-	UPPER LOOPER	1
38	5220	ロツカクネシ/C4	SCREW	1
39	205408	シャクウケト°タイ	BASE	1
40	5095	ヒラネシ/C5	SCREW	2
41	202917	フ°ツシ(マエ)	BUSHING (FRONT)	1
42	5305	ロツカクネシ/C5	SCREW	1
43	202286	ハ°ネサ°カ°ネ	WASHER	1
44	202914	ウフル-ハ°-タイアンナイ	GUIDE	1
45	202915	キユウジフエルト	OIL WICK	1
46	202916	オサエカ°ネ	PLATE	1
47	1231	ヒラネシ/C1	SCREW	1
48	202175	キユウジヒモ	OIL WICK	2
49	202919	フ°ツシ(ウシロ)	BUSHING (REAR)	1
50	202920	トメワ	RING	1
51	202921	ピン	PLUG	1
52	202174	キユウジヒモ	OIL WICK	1
53	202631A	イトクリ/ウフル-ハ°-	THREAD TAKEUP	1
54	5064	ヒラネシ/C5	SCREW	1
55	201089	イトミチ/ウフル-ハ°-	THREAD GUIDE	1
56	5519	ヒラネシ/C3	SCREW	1
57	202875	サ°カ°ネ	WASHER	1
58	205441	イトミチハ°イフ°	THREAD TUBE	1
59	5328	ヒラネシ/C4	SCREW	1
60	205295	イトミチ	THREAD GUIDE	1
61	205771	ウフル-ハ°-タイ(クミ)	UPPER LOOPER HOLDER COMPLETE	1

WWW.COM

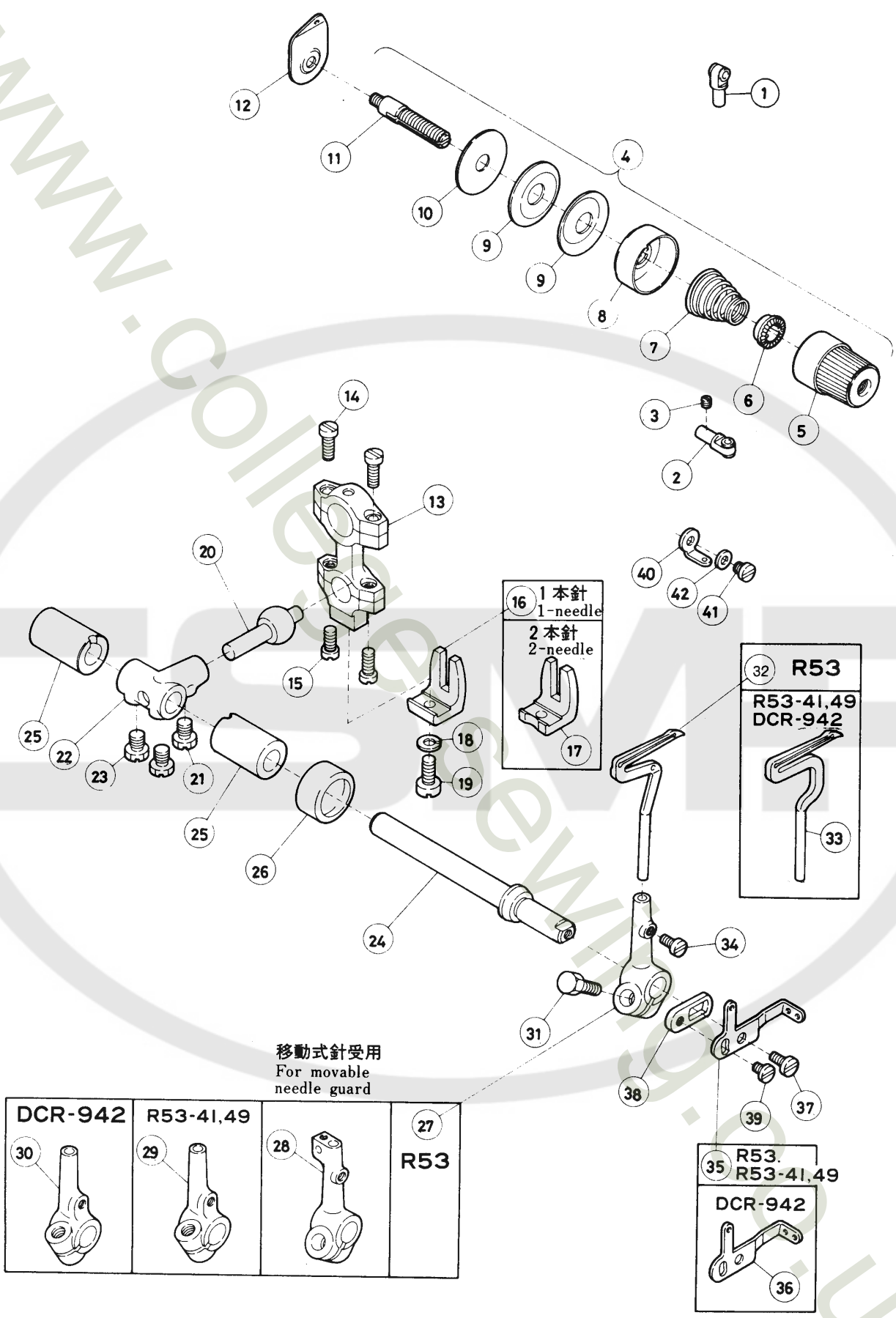

下ルーパー機構

LOWER LOOPER DRIVE MECHANISM

REF. NO.	PART NO.	メイシヨウ	NAME	QT.
1	201048A	イトミチ	THREAD EYELET	1
2	201048A	イトミチ	THREAD EYELET	1
3	1459	トメネシ [〃] /C4	SCREW	1
4	208489	イトチヨウシ(クミ)	THREAD TENSION COMPLETE	1
5	208447	チヨウシナツト	TENSION NUT	1
6	208448	トメハ ^〇 イフ ^〇	SPRING BUSHING	1
7	201086	アツシユクハ ^〇 ネ(チヨウ)	TENSION SPRING (MEDIUM)	1
8	208450	ウケサ ^〇 ラ	CAP	1
9	201482	チヨウシサ ^〇 ラ	DISC	2
10	208449	フェルト	FELT	1
11	5082A	チヨウシホ ^〇 ウ	POST	1
12	202849	チヨウシタ ^〇 イ	TENSION GUIDE PLATE	1
13	201073B	ロツツ [〃] /シタル-ハ ^〇 -	CONNECTION	1
14	5002	ヒラネシ [〃] /C5	SCREW	2
15	1170-1	ヒラネシ [〃] /C4	SCREW	2
16	201074A	フレト [〃] メ	CONNECTION GUIDE	1
17	202790	フレト [〃] メ	CONNECTION GUIDE	1
18	202286	ハ ^〇 ネサ ^〇 カ ^〇 ネ	WASHER	1
19	1156	ヒラネシ [〃] /C5	SCREW	1
20	201075	ロツツ [〃] キユウ	BALL STUD	1
21	5048	ロツカクネシ [〃] /C8	SCREW	1
22	201079A	クランク/シタル-ハ ^〇 -	CRANK/LOWER LOOPER DRIVE	1
23	5048	ロツカクネシ [〃] /C8	SCREW	2
24	201080	シ [〃] ク/シタル-ハ ^〇 -	SHAFT	1
25	205778	フツシユ	BUSHING	2
26	202923	アフ ^〇 ラウケ	RETAINER	1
27	201438A	シタル-ハ ^〇 -タ ^〇 イ	LOWER LOOPER HOLDER	1
28	202728	シタル-ハ ^〇 -タ ^〇 イ	LOWER LOOPER HOLDER	1
29	205409	シタル-ハ ^〇 -タ ^〇 イ	LOWER LOOPER HOLDER	1
30	202736	シタル-ハ ^〇 -タ ^〇 イ	LOWER LOOPER HOLDER	1
31	5274	ロツカクネシ [〃]	SCREW	1
32	202703	シタル-ハ ^〇 -	LOWER LOOPER	1
33	202408	シタル-ハ ^〇 -	LOWER LOOPER	1
34	5328	ヒラネシ [〃] /C4	SCREW	1
35	202633	イトクリ/シタル-ハ ^〇 -	THREAD TAKEUP	1
36	202732	イトクリ/シタル-ハ ^〇 -	THREAD TAKEUP	1
37	2921	ヒラネシ [〃] /C3	SCREW	1
38	201088	ブラケツト	BRACKET	1
39	1202	ヒラネシ [〃] /C4	SCREW	1
40	201809	イトミチ/シタル-ハ ^〇 -	COVER	1
41	5519	ヒラネシ [〃] /C3	SCREW	1
42	202875	サ ^〇 カ ^〇 ネ	WASHER	1

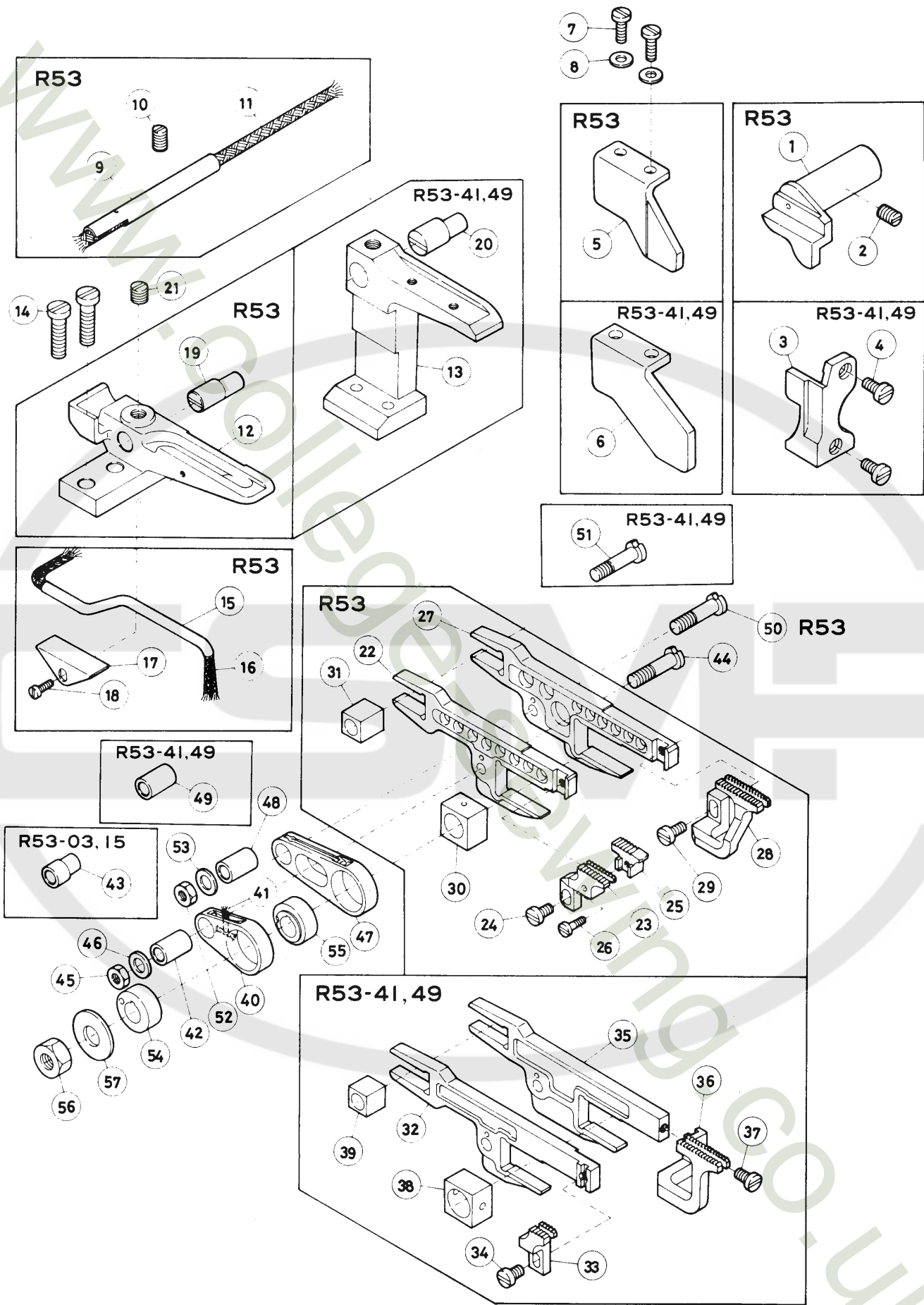

送り機構(1)

FEED MECHANISM(1)

REF. NO.	PART NO. フ*ハ*ン	メイシヨウ	NAME	QT.
1	202941B	オクリタ*イアンナイ(マイ)	FEED BAR GUIDE (FRONT)	1
2	2022-3	トメネシ*/C10	SCREW	1
3	205421A	オクリタ*イアンナイ(マイ)	FEED BAR GUIDE (FRONT)	1
4	5328	ヒラネシ*/C4	SCREW	2
5	201109	オクリタ*イアンナイ(ミキ*)	FEED BAR GUIDE (RIGHT)	1
6	205420	オクリタ*イアンナイ(ミキ*)	FEED BAR GUIDE (RIGHT)	1
7	1175-3	ヒラネシ*/C4	SCREW	2
8	167066	サ*カ*ネ	WASHER	2
9	201110	ハ*イフ*/オクリタ*イキユウ	OIL TUBE	1
10	1435	トメネシ*/C5	SCREW	1
11	202181	キユウヒモ	OIL WICK	1
12	202201A	オクリタ*イアンナイ(ヒタ*リ)	FEED BAR GUIDE (LEFT)	1
13	205422	オクリタ*イアンナイ(ヒタ*リ)	FEED BAR GUIDE (LEFT)	1
14	5095	ヒラネシ*/C5	SCREW	2
15	202202	ハ*イフ*/オクリエキセンキユウ	OIL TUBE	1
16	202176	キユウヒモ	OIL WICK	1
17	202203	オサイカ*ネ	HOLDER	1
18	1196	ヒラネシ*/C3	SCREW	1
19	202200	タ*ンツキヒ*ン	PIN	1
20	205419	タ*ンツキヒ*ン	PIN	1
21	2022	トメネシ*/C10	SCREW	1
22	201093A	シユ オクリ タ*イ	MAIN FEED BAR	1
23	XXXXXX	シユオクリハ*	MAIN FEED DOG	1
24	1202	ヒラネシ*/C4	SCREW	1
25	XXXXXX	ホシ*ヨオクリハ*	AUX. FEED DOG	1
26	5086	ヒラネシ*/C1	SCREW	1
27	201096A	サ*ウ オクリ タ*イ	DIFF. FEED BAR	1
28	XXXXXX	サ*ウオクリハ*	DIFF. FEED DOG	1
29	1202	ヒラネシ*/C4	SCREW	1
30	201106	カクコ*マ/オクリシ*ヨウケ*	BLOCK/FEED BAR LIFT	1
31	205857	カクコ*マ/オクリタ*イアンナイ	BLOCK/FEED BAR GUIDE	1
32	205410	シユオクリタ*イ	MAIN FEED BAR	1
33	XXXXXX	シユオクリハ*	MAIN FEED DOG	1
34	1202	ヒラネシ*/C4	SCREW	1
35	205414	サ*ウ オクリタ*イ	DIFF. FEED BAR	1
36	XXXXXX	サ*ウオクリハ*	DIFF. FEED DOG	1
37	1175-2	ヒラネシ*/C4	SCREW	1
38	205417	カクコ*マ/オクリシ*ヨウケ*	BLOCK/FEED BAR LIFT	1
39	205418	カクコ*マ/オクリタ*イアンナイ	BLOCK/FEED BAR GUIDE	1
40	205850	リンク	LINK	1
41	202175	キユウヒモ	OIL WICK	2
42	201099	フ*ツシユ	BUSHING	1
43	201154	フ*ツシユ	BUSHING	1
44	201100	タ*ンツキネシ*	SCREW	1
45	3044	ワツカクナツ/C5	NUT	1
46	200098	サ*カ*ネ	WASHER	1
47	201101	リンク	LINK	1
48	201099	フ*ツシユ	BUSHING	1
49	206119	フ*ツシユ	BUSHING	1
50	201100	タ*ンツキネシ*	SCREW	1
51	206120	タ*ンツキネシ*	SCREW	1
52	3044	ワツカクナツ/C5	NUT	1
53	200098	サ*カ*ネ	WASHER	1
54	201103B-	オクリエキセン	FEED ECCENTRIC	1
55	201103B-	オクリエキセン	FEED ECCENTRIC	1
56	5213	ワツカクナツ/C12	NUT	1
57	202924	サ*カ*ネ	WASHER	1

送り機構(2)

FEED MECHANISM(2)

REF. NO.	PART NO.	メイシヨウ	NAME	QT.
1	202412	ロツク/オクリセ"ンコ"	CONNECTION/FEED DRIVE	1
2	2213-1	ヒラネシ" /C5	SCREW	2
3	205495	ハイコウヒ"ン	PIN	1
4	1458	トメネシ" /C5	SCREW	1
5	202416	クランク(ミキ")/オクリセ"ンコ"	CRANK (RIGHT)/FEED DRIVE	1
6	5002	ヒラネシ" /C5	SCREW	2
7	202414A	フ"ツシユ	BUSHING	2
8	201139	カラ-	COLLAR	1
9	5084	ロツククネシ" /C5	SCREW	2
10	202413	シ"ク/オクリタ"イ	SHAFT/FEED BAR	1
11	201110	ハ"イフ"	OIL PIPE	1
12	1435	トメネシ" /C5	SCREW	1
13	202176	キ"ウ"ヒモ	OIL WICK	1
14	205842	ハ"イフ"	PIPE	1
15	200174	トメカ"ネ	CLAMP	1
16	5091	ヒラネシ" /C5	SCREW	1
17	205843	キ"ウ"フ"ルト	OIL FELT	1
18	205844	トメカ"ネ	CLAMP	1
19	1227	ヒラネシ" /C3	SCREW	1
20	205845	オクリタ"イアンナイ(ナカ)	FEED BAR GUIDE (CENTER)	1
21	5095	ヒラネシ" /C5	SCREW	2
22	202420B	オクリ タ"イ アンナイ (マ"イ)	FEED BAR GUIDE (FRONT)	1
23	2022-3	トメネシ" /C10	SCREW	1
24	202422	オクリ タ"イ アンナイ (ウシロ)	FEED BAR GUIDE (REAR)	1
25	1175-3	ヒラネシ" /C4	SCREW	2
26	167066	サ"カ"ネ	WASHER	2
27	201096A	オクリタ"イ	FEED BAR	1
28	202733	オクリハ"	FEED DOG	1
29	1202	ヒラネシ" /C4	SCREW	1
30	202734	ホシ"ヨ オクリハ"	AUX. FEED DOG	1
31	5003	ヒラネシ" /C3	SCREW	1
32	205417	カクコ"マ/オクリシ"ヨウケ"	BLOCK/FEED BAR LIFT	1
33	201107	オクコ"マ/オクリタ"イアンナイ	BLOCK/FEED BAR GUIDE	1
34	202417	オクリ レンゲツ カ"ン	CONNECTING LINK	1
35	202309	フ"ツシユ	BUSHING	1
36	202310	タ"ンツキネシ"	SCREW	1
37	3044	ロツククナツト/C5	NUT	1
38	200098	サ"カ"ネ	WASHER	1
39	202395A	クランク(ヒタ"リ)/オクリセ"ンコ"	CRANK (LEFT)/FEED DRIVE	1
40	2237	ヒラネシ" /C5	SCREW	2
41	202781	スフ"リンク"ヒ"ン	PIN	1
42	202418	タ"ンツキヒ"ン	PIN	1
43	200098	サ"カ"ネ	WASHER	1
44	3044	ロツククナツト/C5	NUT	1

WWW

DCR-942

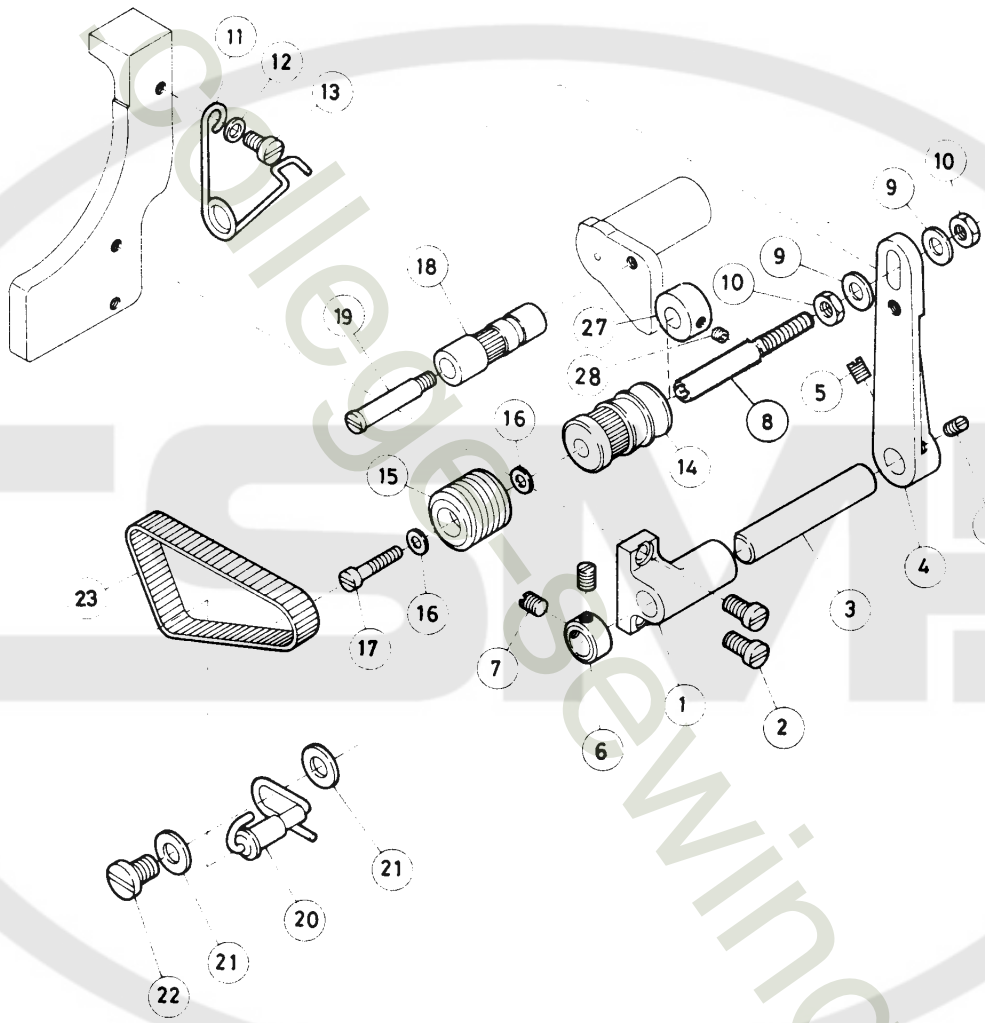

送り機構(3)
DCR-942専用

FEED MECHANISM(3)
FOR DCR-942 ONLY

REF. PART NO. NO.	フ ャ ハ ン	メイシヨウ	NAME	QT.
1	202438	シヅクケ	BUSHING	1
2	1174	ヒラネシヅ/C4	SCREW	2
3	202426	シヅク	PIN	1
4	202425	ブラケット	BRACKET	1
5	1457	トメネシヅ/C5	SCREW	2
6	202427	カラー	COLLAR	1
7	1457	トメネシヅ/C5	SCREW	2
8	205892	タツキネシヅ	SCREW	1
9	201185	サカカネ	WASHER	2
10	3044	ロツカクナツ/C5	NUT	2
11	202428	ヘンサイクハネ	SPRING	1
12	137906	サカカネ	WASHER	1
13	1216	ヒラネシヅ/C4	SCREW	1
14	202423	オクリローラ-(マE)	FEED ROLLER (FRONT)	1
15	202429	ウオーム/フノアンナイ	WORM/FABRIC GUIDE	1
16	200821	サカカネ	WASHER	2
17	2928	ヒラネシヅ/C4	SCREW	1
18	202430	オクリローラ-(ウシD)	FEED ROLLER (REAR)	1
19	202442	タツキネシヅ	SCREW	1
20	202449	オクリローラ-(シタ)	FEED ROLLER (LOWER)	1
21	202433	サカカネ	WASHER	2
22	5092	ヒラネシヅ/C9	SCREW	1
23	202431-1	フノオクリベルト/118ヤマ	FEED BELT/118 PITCHES	1
24	202431-2	フノオクリベルト(キ)/123ヤマ	FEED BELT/123 PITCHES/YELLOW	1
25	202431-3	フノオクリベルト(アカ)/128ヤマ	FEED BELT/128 PITCHES/RED	1
26	202431-4	フノオクリベルト(シロ)/144ヤマ	FEED BELT/144 PITCHES/WHITE	1
27	205893	カラー	COLLAR	1
28	5292	トメネジ	SCREW	1

WWW

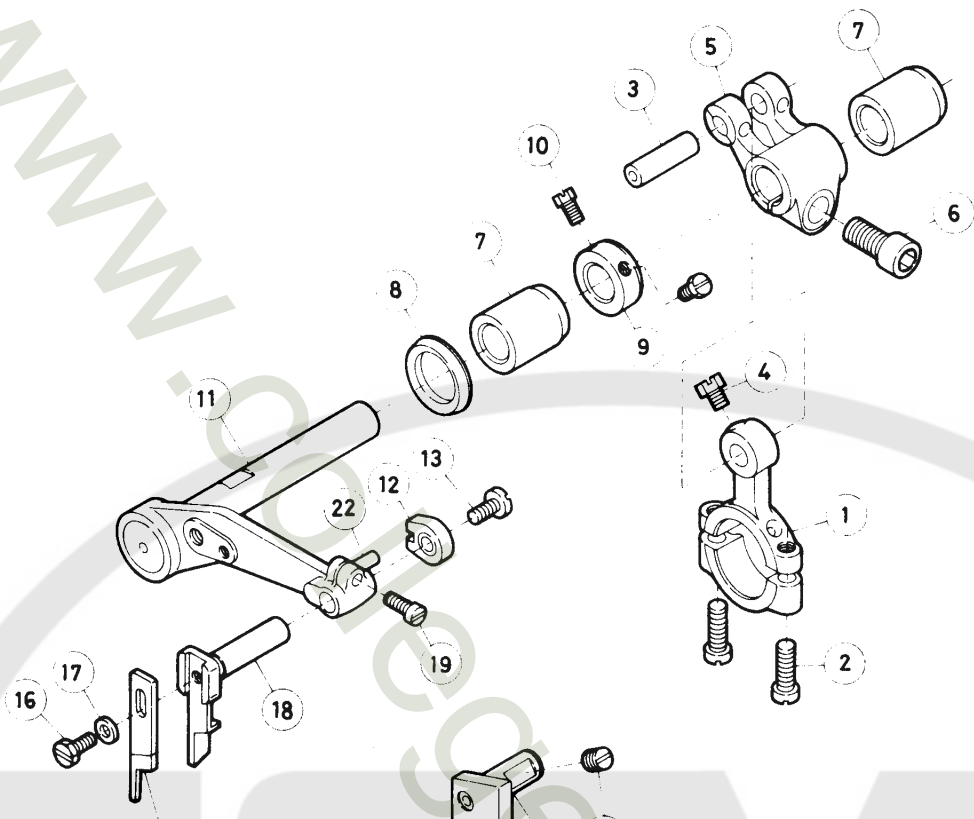

1 本針 1-needle	14
2 本針 2-needle	15

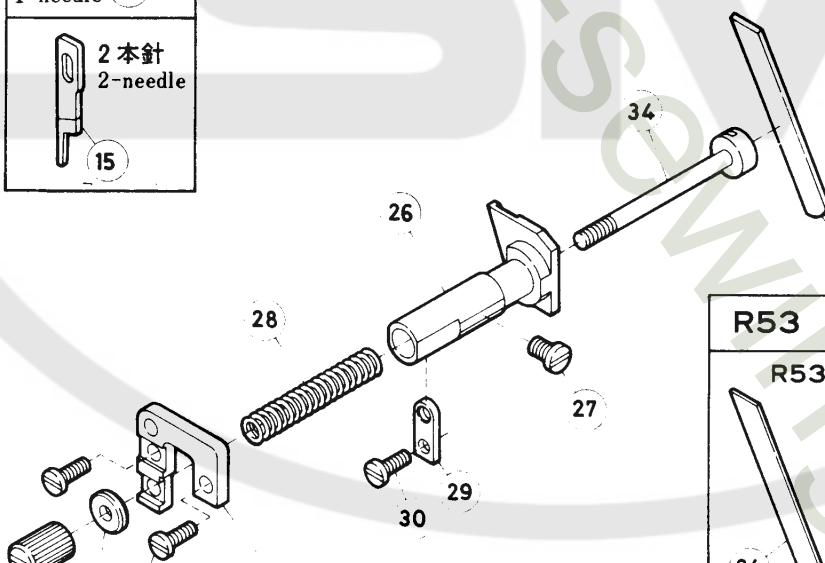

R53	23
R53	R53-41,49
24	25

35	36	33
37	~R53-41	

31	R53
R53-41,49	
32	

KYU-UK

上下メス機構

UPPER AND LOWER KNIFE MECHANISM

REF. NO.	PART NO.	メイシヨウ	NAME	QT.
1	202925	ロツツ/ウフメス	CONNECTION/UPPER KNIFE DRIVE	1
2	5187	ヒラネシム/C5	SCREW	2
3	205495	ハコウヒン	PIN	1
4	5084	ロツカクネシム/C5	SCREW	1
5	201381A	クランク/ウフメス	CRANK/UPPER KNIFE DRIVE	1
6	5381	ヒラネシム/C10	SCREW	1
7	201115A	フツシユ	BUSHING	2
8	202927	オイルシール	OIL SEAL	1
9	201117	カラー	COLLAR	1
10	5328	ヒラネシム/C4	SCREW	2
11	205292	ウフメスタイ	LEVER	1
12	202638B	ウフメス タキ アンナイ	GUIDE	1
13	1189	ヒラネシム/C4	SCREW	1
14	201121A	ウフメス	UPPER KNIFE	1
15	205258	ウフメス	UPPER KNIFE	1
16	5088	ロツカクネシム/C4	SCREW	1
17	211376	サカガネ	WASHER	1
18	202637B	ウフメス タキ	UPPER KNIFE HOLDER	1
19	1175-2	ヒラネシム/C4	SCREW	1
20	202636	ウフメス タイ アンナイ	GUIDE	1
21	2022	トメネシム/C10	SCREW	1
22	201125	ハコウヒン	PIN	1
23	202295	シタメス	LOWER KNIFE	1
24	201127	シタメス	LOWER KNIFE	1
25	205423	シタメス	LOWER KNIFE	1
26	202739	シタメス タイ	LOWER KNIFE HOLDER	1
27	4009-1	ヒラネシム/C5	SCREW	1
28	201129	アツシユクハネ	SPRING	1
29	201130A	ハネオサヒ	RETAINER	1
30	1175-3	ヒラネシム/C4	SCREW	1
31	201131A	アンナイイタ	GUIDE/LOWER KNIFE HOLDER	1
32	205424	アンナイイタ	GUIDE/LOWER KNIFE HOLDER	1
33	1175-3	ヒラネシム/C4	SCREW	2
34	201132B	シタメス トメヒン	LOWER KNIFE CLAMP STUD	1
35	5260	マルナツト	NUT	1
36	201134	サカガネ	WASHER	1
37	5111	ロツカクナツト/C5	NUT	1

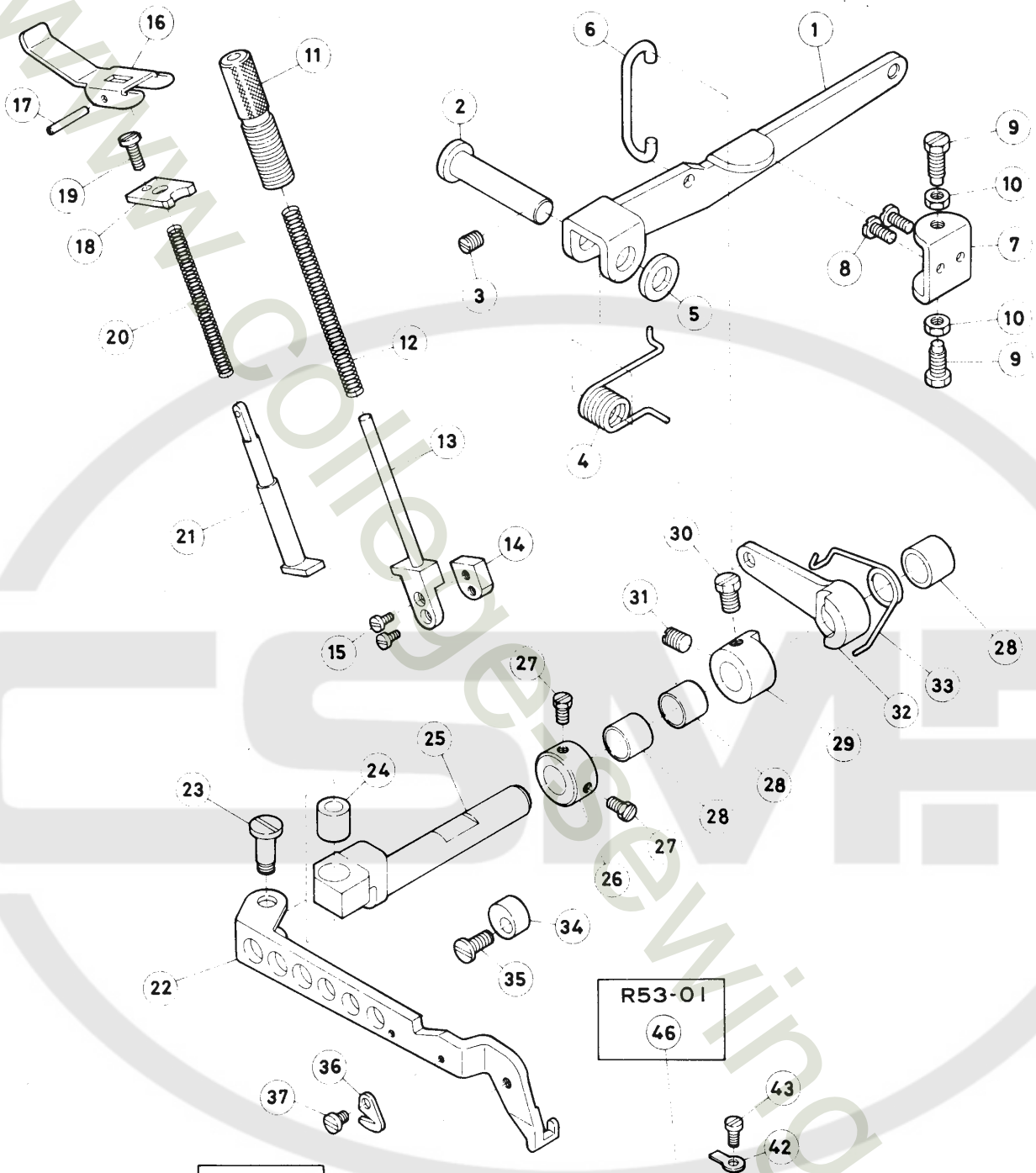

R53-01
46

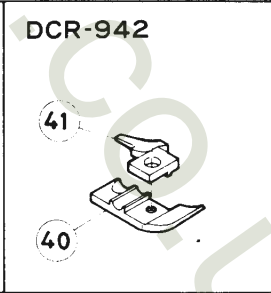
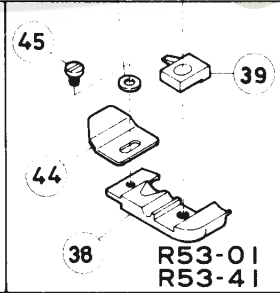
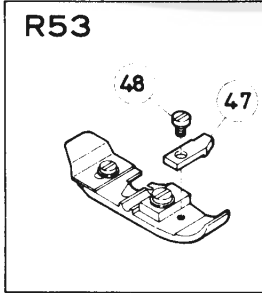
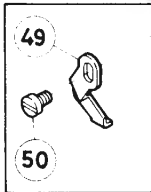

押工機構

PRESSER FOOT MECHANISM

REF. NO.	PART NO.	メイシヨウ	NAME	QT.
1	201160B	アシアケ [〃] (タイ)	FOOT LIFT LEVER	1
2	201161	タ [〃] ンツキヒ [〃] ン	STUD	1
3	2022-3	トメネシ [〃] /C10	SCREW	1
4	201162A	ネシ [〃] リハ [〃] ネ	SPRING	1
5	202868	サ [〃] カ [〃] ネ	WASHER	1
6	205702	レンケツヒ [〃] ン	PIN	1
7	201167A	チヨウセツタ [〃] イ	BRACKET	1
8	5142	ヒラネシ [〃] /C4	SCREW	2
9	5097	タ [〃] ンツキネシ [〃] /C5	SCREW	2
10	3044	ロツカクナツト/C5	NUT	2
11	205719	チヨウセツネシ [〃]	SCREW	1
12	208773	アツシユクハ [〃] ネ	PRESSER BAR SPRING	1
13	202641	オサ [〃] イ ホ [〃] ウ	PLUNGER	1
14	202642	オサ [〃] イホ [〃] ウ [〃] ヘ [〃] ン	GUIDE	1
15	5053	ヒラネシ [〃] /C4	SCREW	2
16	208598	テアケ [〃]	HAND LIFT LEVER	1
17	202647A	スフ [〃] リンク [〃] ヒ [〃] ン	HINGE PIN	1
18	208599	フ [〃] ツシ [〃]	BUSHING	1
19	5029	ヒラネシ [〃] /C3	SCREW	1
20	201395	アツシユクハ [〃] ネ	SPRING	1
21	202645	シ [〃] ク/テアケ [〃]	PLUNGER	1
22	202639	オサ [〃] イ タイ	ARM	1
23	5164	タ [〃] ンツキネシ [〃] /C8	SCREW	1
24	201141	フ [〃] ツシ [〃]	BUSHING	1
25	202640A	シ [〃] ク	SHAFT/FOOT LIFT	1
26	202756	カラ [〃]	COLLAR	1
27	5084	ロツカクネシ [〃] /C5	SCREW	2
28	202589	フ [〃] ツシ [〃]	BUSHING	3
29	201164A	カラ [〃]	COLLAR	1
30	2022-4	ロツカクネシ [〃] /C10	SCREW	1
31	2022	トメネシ [〃] /C10	SCREW	1
32	205704	アシアケ [〃] (シヨウ)	INTERMEDIATE LEVER	1
33	205705	ネシ [〃] リハ [〃] ネ	SPRING	1
34	202683	ストツハ [〃]	REGULATOR	1
35	5345	ヒラネシ [〃] /C5	SCREW	1
36	202451	チ [〃] インカツター	CHAINCUTTER	1
37	2921	ヒラネシ [〃] /C3	SCREW	1
38	201152E	オサ [〃] イ	PRESSER FOOT	1
39	201155C	オサ [〃] イ ツメ	PRESSER FOOT FINGER	1
40	202434	オサ [〃] イ	PRESSER FOOT	1
41	202453A	オサ [〃] イツメ	FINGER	1
42	201156	トリツケイタ	SPRING	1
43	5089	ヒラネシ [〃] /C3	SCREW	1
44	210584	ホシ [〃] ヨイタ	UNCURLER	1
45	5030	ヒラネシ [〃] /C1	SCREW	1
46	210585	サ [〃] カ [〃] ネ	WASHER	1
47	201265B	ホシ [〃] ヨ オサ [〃] イ	FABRIC GUARD	1
48	1231	ヒラネシ [〃] /C1	SCREW	1
49	202682A	コテイカ [〃] ネ	PRESSER FOOT REGULATOR	1
50	1196	ヒラネシ [〃] /C3	SCREW	1

給油機構

LUBRICATING MECHANISM

REF. NO.	PART NO. フマホン	メイショク	NAME	QT.
1	205378	ギヤ-ポンプ (クミ)	GEAR PUMP	1
2	2213-1	ヒラネシ/C5	SCREW	4
3	201288A	ケースング (クミ)	CASING COMPLETE	1
4	201293A	ソクイタ	PLATE	1
5	5117	ヒラネシ/C5	SCREW	4
6	205887	ギヤ(A)/ポンプ	PUMP GEAR (RIGHT)	1
7	201295	ギヤ (B)	PUMP GEAR	1
10	201297	シャフト(B)	SHAFT	1
11	1458	トメネシ/C5	SCREW	2
12	201299	ウオーム ホイル	WORM WHEEL	1
13	5060	トメネシ/C8	SCREW	2
14	201338	フィルター (クミ)	FILTER COMPLETE	1
15	201341	トリツケイタ	FILTER FRAME	1
16	1175-2	ヒラネシ/C4	SCREW	3
17	201300A	ツキテ	OIL SPLASH JOINT	1
18	201301	ツキテネシ	OIL SPLASH SCREW	1
19	201319A	チューブ	TUBE	1
20	201304	ホコハネ	SPRING	1
21	201303	クランプ	TUBE CLAMP	2
22	201300A	ツキテ	OIL SPLASH JOINT	2
23	201301	ツキテネシ	OIL SPLASH SCREW	2
24	202928	アブラハイフンキ	DISTRIBUTOR	1
25	1156	ヒラネシ/C5	SCREW	1
26	200136	ツキテ	OIL SPLASH JOINT	2
27	200152	ツキテネシ	OIL SPLASH SCREW	2
28	205763	チューブ	OIL TUBE	1
29	202199	クランプ	TUBE CLAMP	2
30	202193	チューブ/6X9X170	VINYL TUBE	1
31	205294	ホコハネ	CLAMP SPRING	1
32	201303	クランプ	TUBE CLAMP	2
33	202929	チューブ/6X9X140	OIL TUBE	1
34	202930	ホコハネ	CLAMP	1
35	201422B	アブラ ハイフン キ	DISTRIBUTOR	1
36	201423	カステット	GASKET	1
37	5095	ヒラネシ/C5	SCREW	3
38	202794	ファン ヒョウシキ (クミ)	INDICATOR COMPLETE	1
39	201328	オイル マット	OIL SPLASH SIGHT WINDOW	1
40	201329	カステット	GASKET	1
41	202777	ワッシャー	WASHER	1
42	1175-3	ヒラネシ/C4	SCREW	3
43	200136	ツキテ	OIL SPLASH JOINT	1
44	200137	ツキテネシ	OIL SPLASH SCREW	1
45	201426A	チューブ/4X7X35	OIL TUBE	1
46	202199	クランプ	TUBE CLAMP	2
47	201424A	ファン カン	OIL SPLASH PIPE	1
48	5261	ヒラネシ/C7	SCREW	1
49	202775	コムフツシ	BUSHING	1
50	202776	ワッシャー	WASHER	2
51	5020	ロツカクツツ/C10	NUT	1
52	205833	オイルハシ (クミ)	OIL RESERVOIR COMPLETE	1
53	205768	オイルハシ	OIL RESERVOIR	1
55	5138B	ヒラネシ/H11	SCREW	1
56	202287A	カステット	WASHER	1
57	209150	カセ アンタイ	AIR GUIDE	1
58	5441	ヒラネシ/C5	STOP SCREW	2
59	202286	ワッシャー	WASHER	2
60	201335	カステット	GASKET	1
61	205440	カステット	OIL PAN GASKET	1
62	5150B	ヒラネシ/C12	BOLT	4
63	5208B	ヒラネシ/C12	BOLT	4
64	204806	カステット	WASHER	4
65	202737	アンタイ	REGULATOR	1
66	5113	ヒラネシ/C5	SCREW	1
67	200138	ガスケツト	GASKET	2

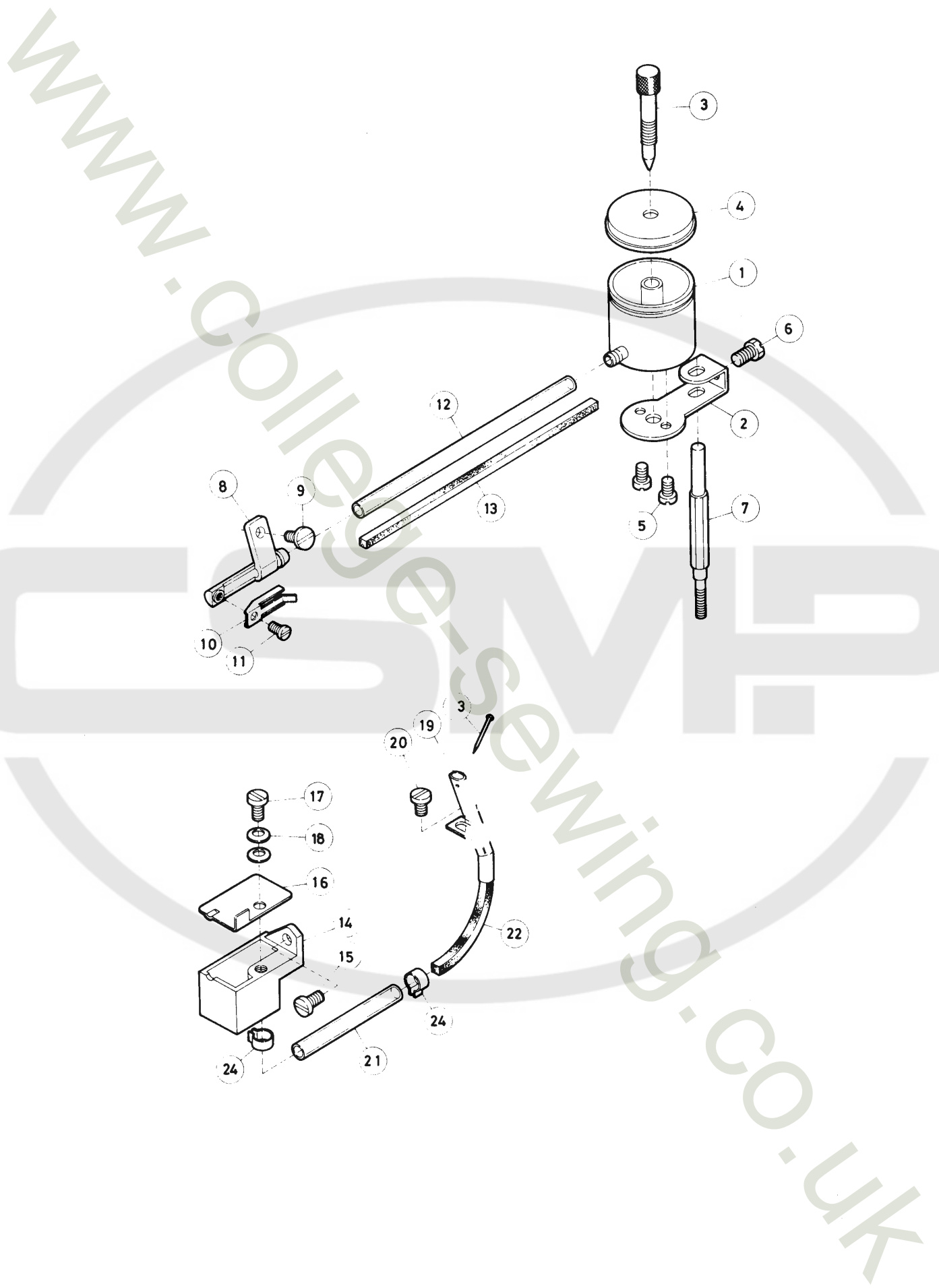

HR装置

HR DEVICE
(Needle and Thread Lubricators)

REF. NO.	PART NO.	メイショウ	NAME	QT.
1	202476-1	シリコンタンク(ウイ)	SILICONE OIL RESERVOIR	1
2	202476-2	トリツケイタ	BRACKET	1
3	202476-3	シリヨウチヨウセツホウ	SILICONE OIL REGULATOR	1
4	202476-4	フタ	CAP COVER	1
5	1216	ヒラネシメ/C4	SCREW	2
6	2193	ロツカクネシメ/C5	SCREW	1
7	202461	トリツケホウ	SCREW STUD	1
8	208446	シリコンハーフ(ウイ)	THREAD LUBRICATOR	1
9	4009-1	ヒラネシメ/C5	SCREW	1
10	208487	アテカンネ	PLATE	1
11	5012	ヒラネシメ/C3	SCREW	1
12	202030A	チューブ/4X6X140	OIL TUBE	1
13	200633	キョウワフィル	OIL WICK	1
14	202455	シリコンタンク(シタ)	SILICONE OIL RESERVOIR	1
15	5117	ヒラネシメ/C5	SCREW	1
16	202456	フタ	CAP COVER	1
17	5184	タツツキネシメ/C5	SCREW	1
18	201191	ハネサカカンネ	WASHER	2
19	202745A	シリコンハーフ(シタ)	NEEDLE COOLER	1
20	4009-1	ヒラネシメ/C5	SCREW	1
21	202472	チューブ/4X6X65	OIL TUBE	1
22	200633	キョウワフィル	OIL WICK	1
23	210766	トメピン	OIL FELT PIN	1
24	202199	クランプ	HOLDER	2

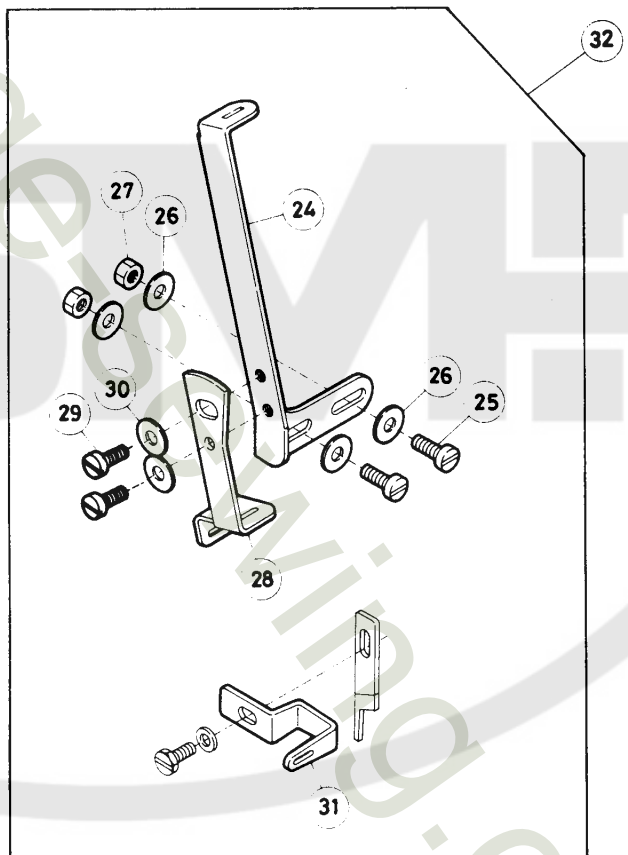
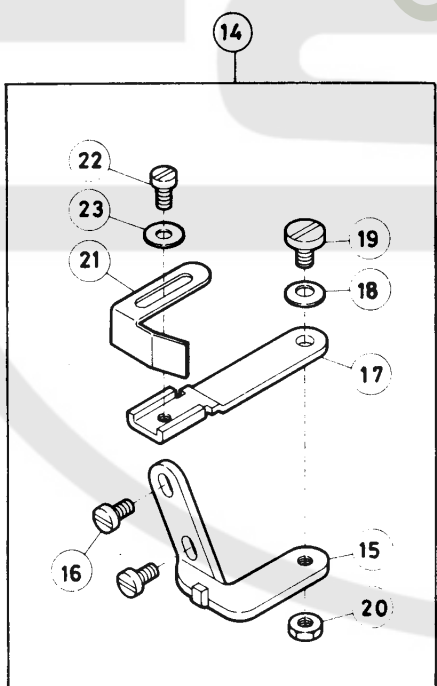
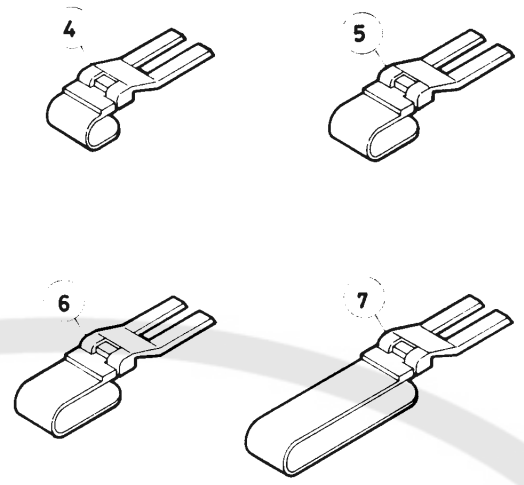
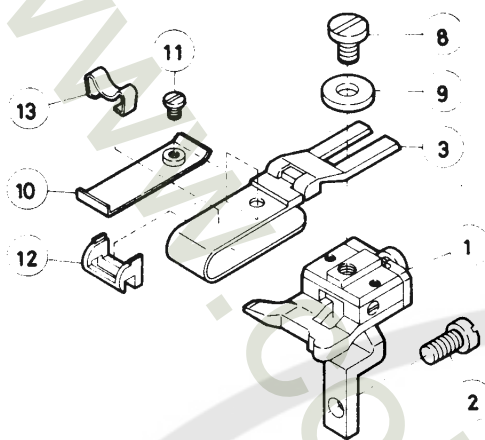

アタッチメント/特別注文品

ATTACHMENTS/SPECIAL ORDER PARTS

REF. NO.	PART NO.	メイシヨウ	NAME	QT.
1	201206A	スツビキシヨウキタイ	WELT GUIDE HOLDER	1
2	1175-2	ヒラネシ/C4	SCREW	1
3	201211B	シヨウキハネ(40MM)	FOLDER/40MM	1
4	205457	シヨウキハネ(14MM)	FOLDER/14MM	1
5	205678	シヨウキハネ(21MM)	FOLDER/21MM	1
6	205679	シヨウキハネ(26MM)	FOLDER/26MM	1
7	205456	シヨウキハネ(51MM)	FOLDER/51MM	1
8	2905	ヒラネシ/C5	SCREW	1
9	137142	サカネ	WASHER	1
10	205835	ホシヨハネ	AUXILIARY	1
11	5299	ヒラネシ/C3	SCREW	1
12	303312A	ハネコマ	FOLDER REGULATOR	1
13	303313	イタハネ	CLAMP	1
14	201500	アテシヨウキ(クミ)	EDGE GUIDE COMPLETE	1
15	201232A	ブラケット(A)	BRACKET	1
16	1202	ヒラネシ/C4	SCREW	2
17	201485	ブラケット(B)	BRACKET	1
18	201191	サラハネ	WASHER	1
19	5184	タンツキネシ/C5	SCREW	1
20	3044	ロツカクナツ/C5	NUT	1
21	201233A	アテシヨウキ	EDGE GUIDE	1
22	1202	ヒラネシ/C4	SCREW	1
23	137906	サカネ	WASHER	1
24	208915	テープアンナイ(ウエ)	TAPE GUIDE (UPPER)	1
25	1175-3	ヒラネシ/C4	SCREW	2
26	137906	サカネ	WASHER	4
27	3091	ロツカクナツ/C4	NUT	2
28	208916	テープアンナイ(シタ)	TAPE GUIDE (LOWER)	1
29	1216	ヒラネシ/C4	SCREW	2
30	137906	サカネ	WASHER	2
31	205319	テープサハキ	TAPE TAKEUP	1
32	209402-91	テープアンナイ(クミ)	TAPE GUIDE COMPLETE	1

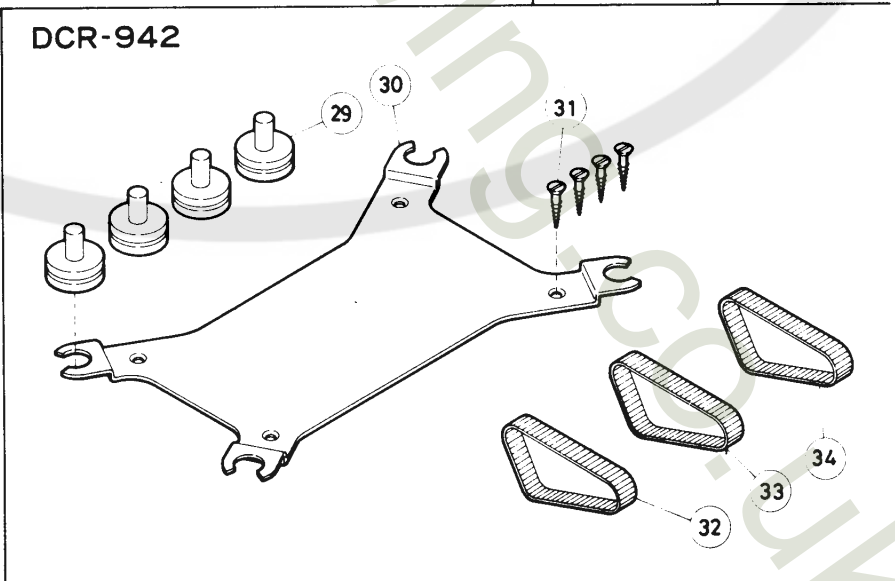
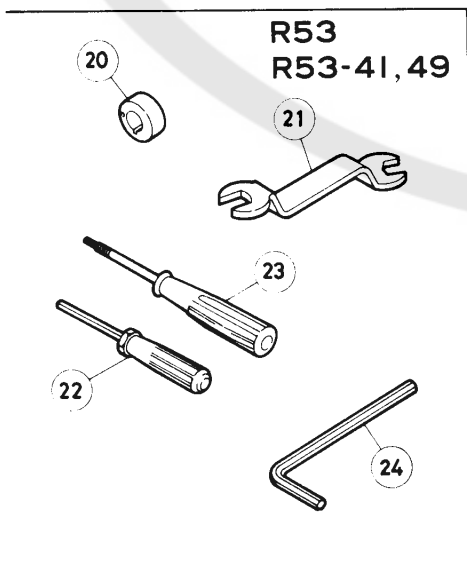
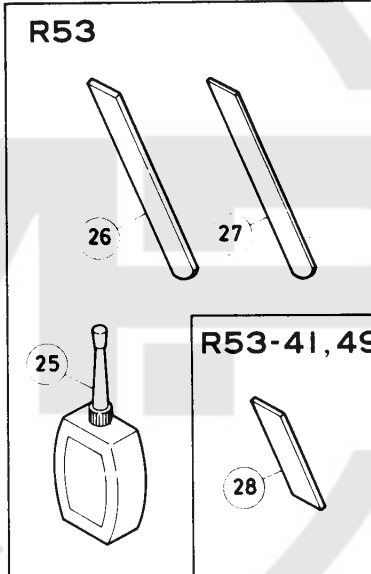
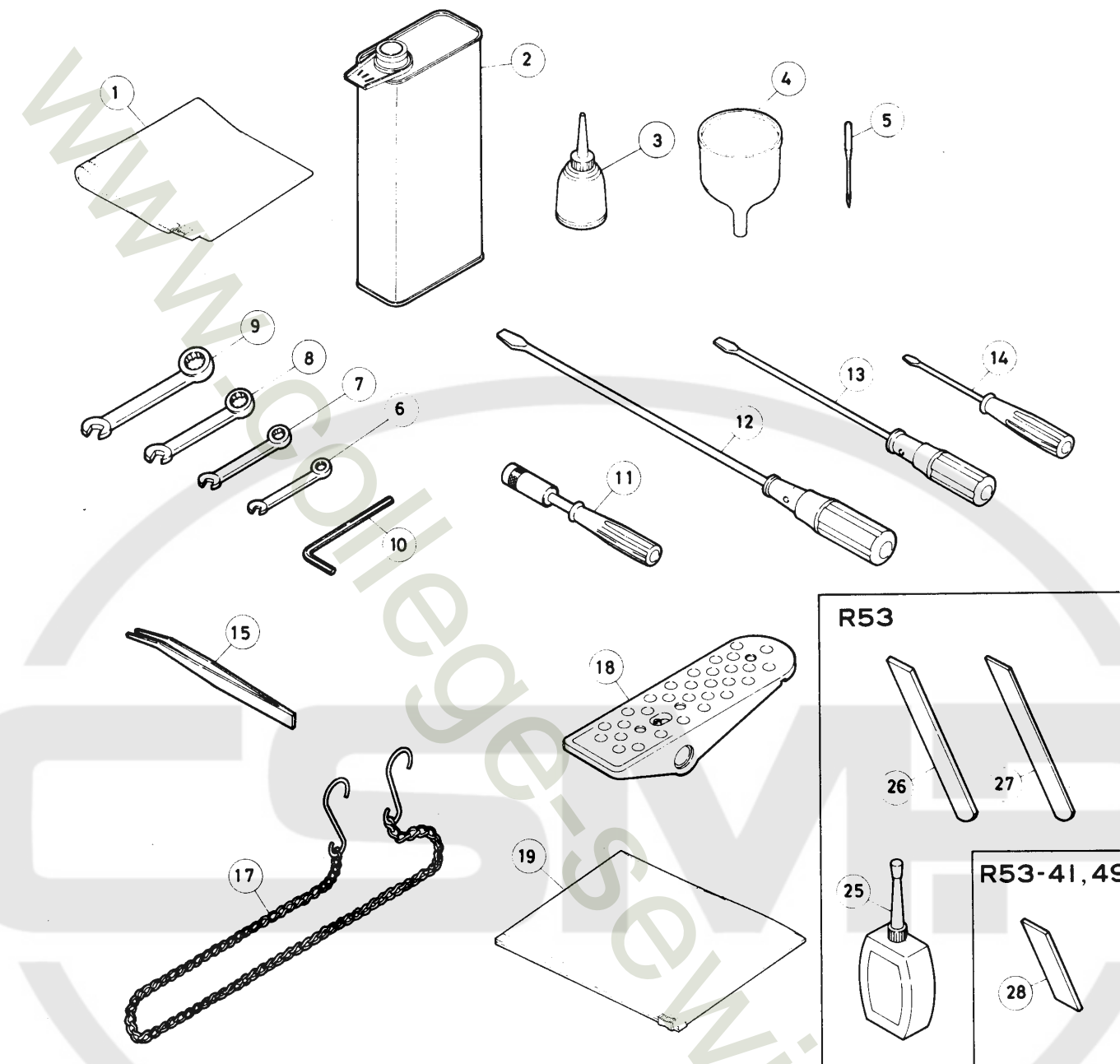

付属品

ACCESSORIES

REF. NO.	PART NO.	メイシヨウ	NAME
1	908	ナイロンカバー	DUST COVER
2	452	アブラカン(750CC)	OIL CONTAINER
3	485	アブラサシ	OILER
4	484	シヨウコ	FUNNEL
5	DCX1	ハリ	NEEDLE
6	282	スパナ/5MM	WRENCH/5MM
7	283	スパナ/6MM	WRENCH/6MM
8	284	スパナ/7MM	WRENCH/7MM
9	286	スパナ/9.5MM	WRENCH/9.5MM
10	200	キーレンチ/4.76MM	WRENCH/4.76MM
11	152	ホツクストライバー/7MM	WRENCH/7MM
12	127	ドライバー(タイ)	DRIVER
13	128	ドライバー(チウ)	DRIVER
14	129	ドライバー(シヨウ)	DRIVER
15	131	ピンセット	TWEEZERS
17	126	クサリ/マル	CHAIN
18	478	ハタル	TREADLE
19	482	アクセサリバッグ	ACCESSARY BAG
20	201103B	オクリエキセン	FEED ECCENTRIC
21	130A	スパナ(12X14)	WRENCH(12X14)
22	179	キーレンチドライバー/1.56MM	ALLEN KEY DRIVER/1.56MM
23	154	エキセンエキトリク	EXTRACTOR/FEED ECCENTRIC
24	272	キーレンチ/6.0MM	ALLEN KEY
25	178	シリコンオイル/50CC	CONTAINER - SILICONE
26	201127	シタメス	LOWER KNIFE
27	202295	シタメス	LOWER KNIFE
28	205423	シタメス	LOWER KNIFE
29	201480	クツシヨンコ	CUSHION PLUG
30	201479	トメイタ	PLATE
31	4909	モクネジ	SCREW
32	202431-3	ヌノオクリベルト(アカ)/128ヤマ	FEED BELT
33	202431-2	ヌノオクリベルト(キ)/123ヤマ	FEED BELT
34	202431-4	ヌノオクリベルト(シロ)/144ヤマ	FEED BELT

SW = 縫巾

SW = Seam Width.

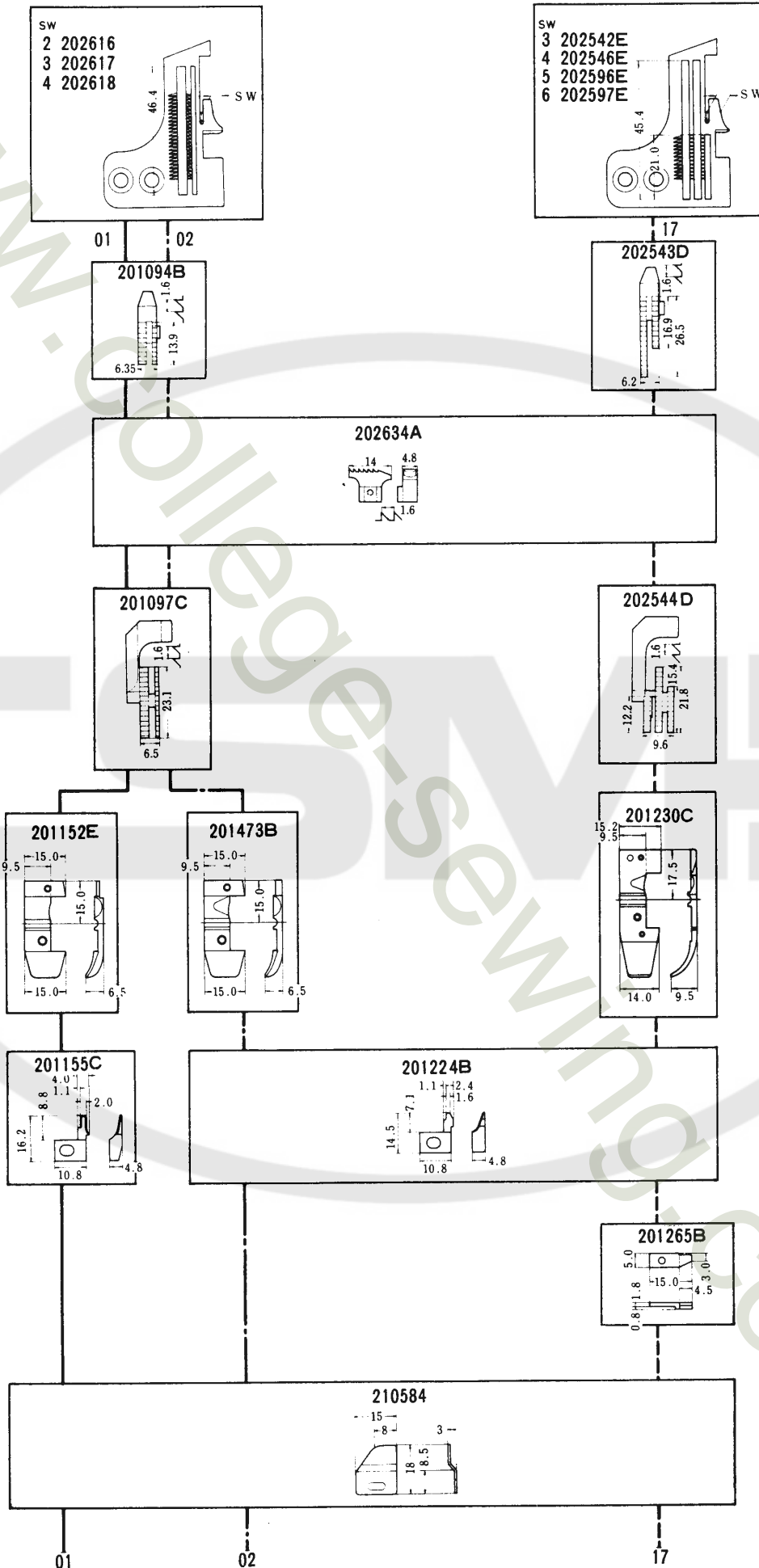

41頁まで。
Up to page 41.

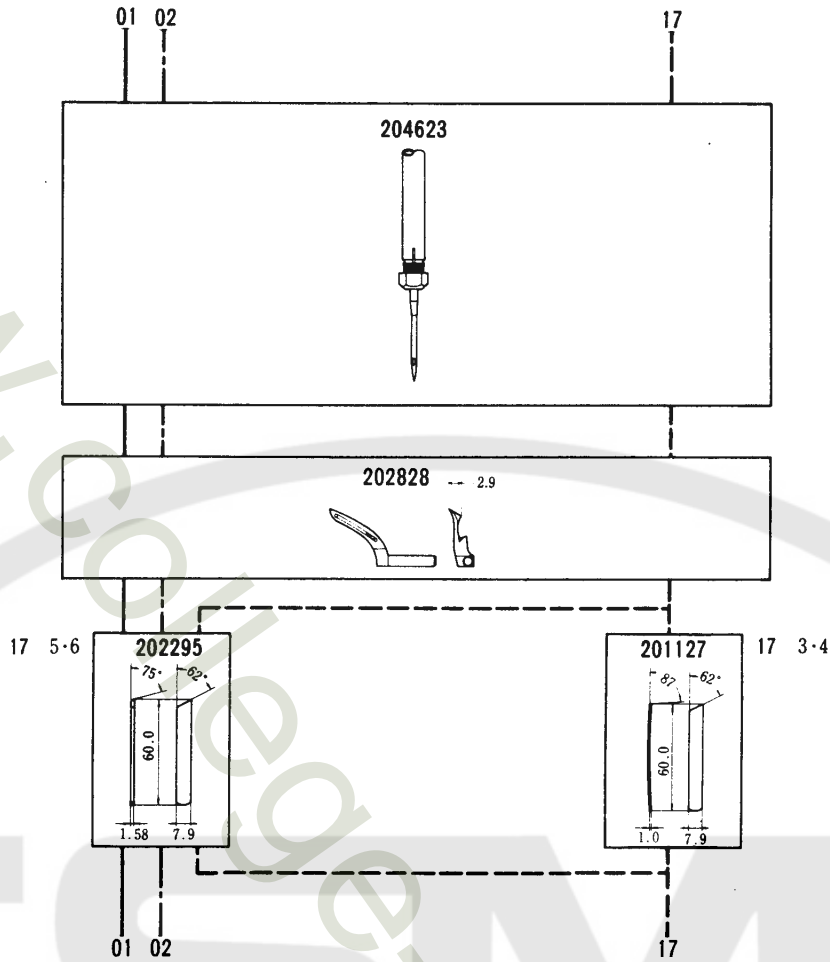

共通パーツ Common parts	
202703	
201453B	
202474A	
201121A	
主送り Main Feed	差動送り Diff. Feed
12	10
5.5	5.5
R53-03	

R53-01	2, 3, 4	505	8-14	薄生地、中厚生地の裾引及び地縫 一般メリヤス肌着 (U首シャツ、ランニング、ショーツ)	Three thread blindstitch hemming on U-necked undershirts athletic shirts, mens and womens briefs etc.
R53-02	2, 3, 4	504	8-14	薄生地、中厚生地の地縫 (メリヤス肌着、婦人子供服)	For sleeve, side and shoulder closing operations on light to medium weight materials such as underwear and ladies' and children's outerwear.
R53-17	3, 4, 5, 6	504	8-14	薄生地、中厚生地の地縫 (セーター、婦人子供服、スラックス)	For sleeve, side and shoulder closing operations on light to medium weight materials such as underwear and ladies' and children's outerwear.
R53-81	2, 3, 4	505	8-14	合織の薄生地、中厚生地の裾引及び地縫 ●H.R装置付 婦人用下着(スリッパ、 negligie)	Same as R53-01, but with needle cooler and thread lubricator (HR device)

SW = 縫巾

SW = Seam Width.

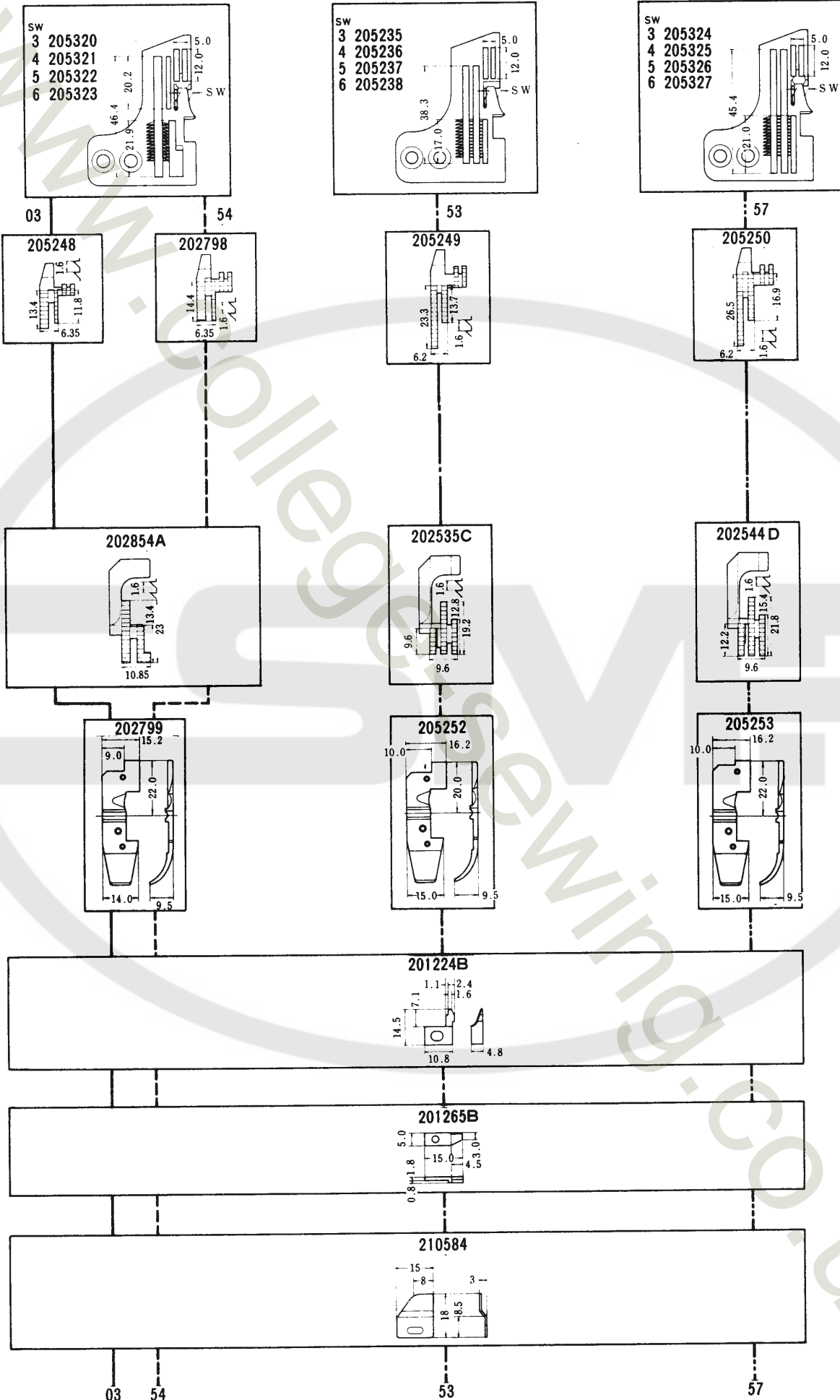

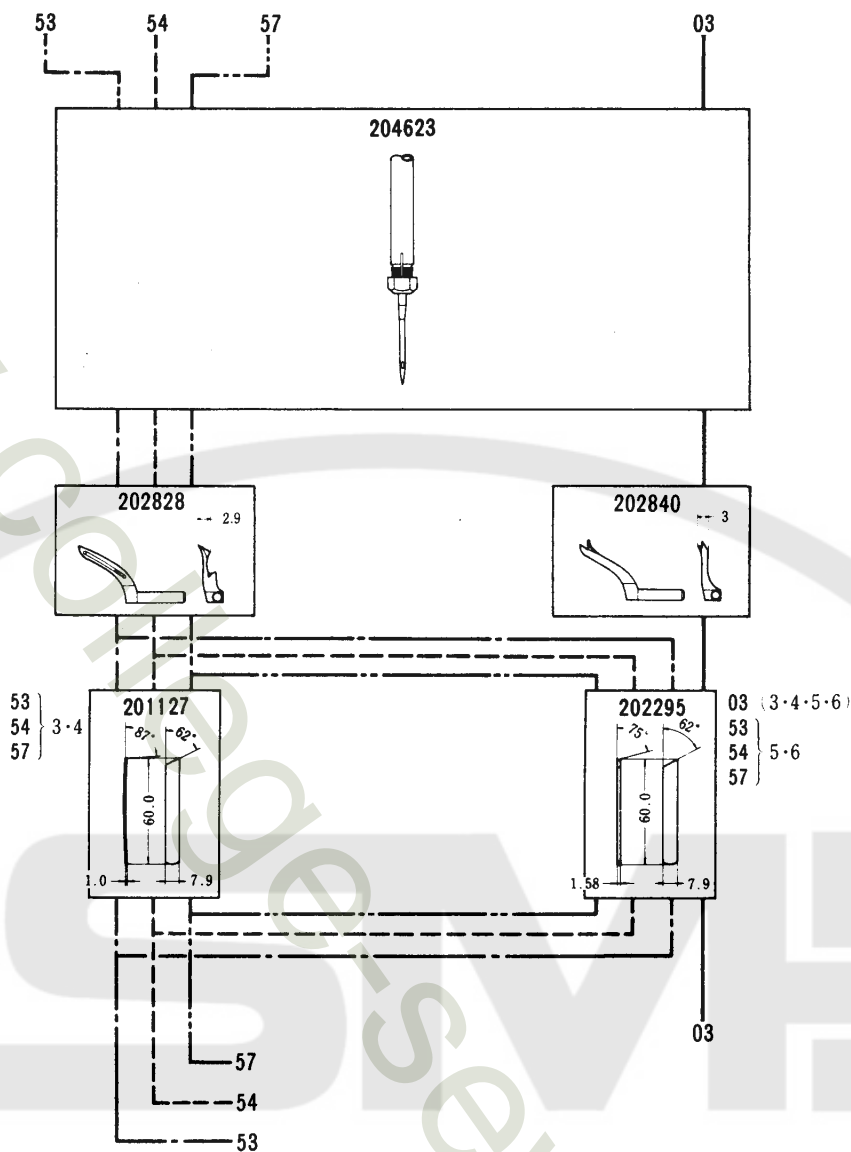

R53-03	3, 4, 5, 6	503	5.5-7	中厚生地のステ縫 (学生服、ズボン、ジャケット)	General serging operations on slacks, jackets working wear etc.
R53-53	3, 4, 5, 6	504	8-14	薄生地、中厚生地の地縫 (下着、セーター、ドレス)	For sleeve, side and shoulder closing operations on light to medium weight materials such as underwear and ladies' and children's outerwear.
R53-54	3, 4, 5, 6	504	8-14	薄生地、中厚生地の地縫 (婦人子供服、スポーツ着)	For sleeve, side and shoulder closing operations on light to medium weight materials such as underwear and ladies' and children's outerwear.
R53-57	3, 4, 5, 6	504	8-14	中厚生地の地縫 (ベッドカバー、椅子カバー)	For sleeve, side and shoulder closing operations on light to medium weight materials such as underwear and ladies' and children's outerwear.

ゲージパーツ系列構成図

R53-05, 09, 15, 55, 59

GAUGE PARTS CONSTRUCTION CHART

SW = 縫巾
NG = 針巾

SW = Seam Width.
NG = Needle Gauge.

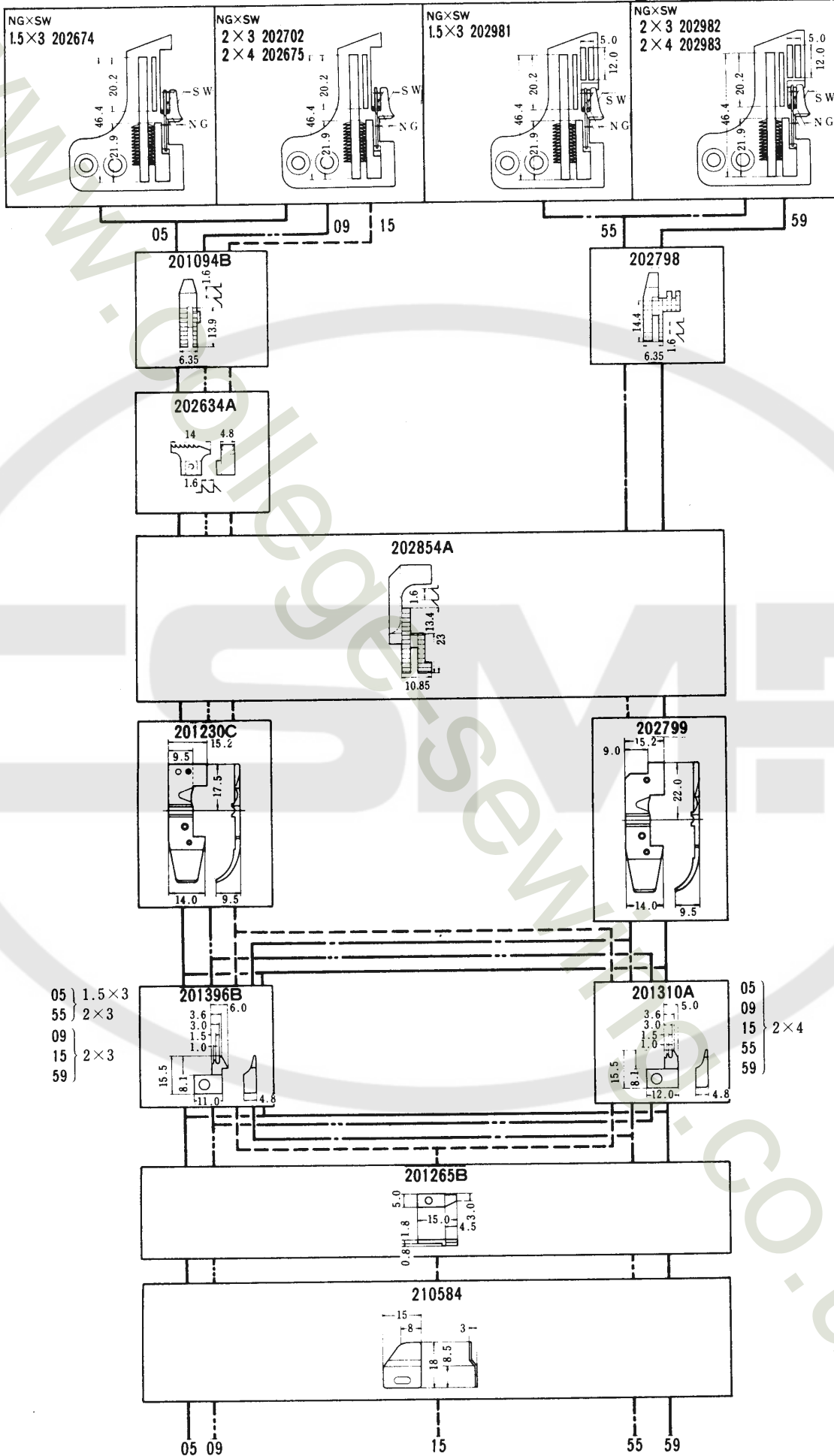

05 } 1.5×3
55 } 2×3
09 }
15 } 2×3
59 }

05 }
09 }
15 } 2×4
55 }
59 }

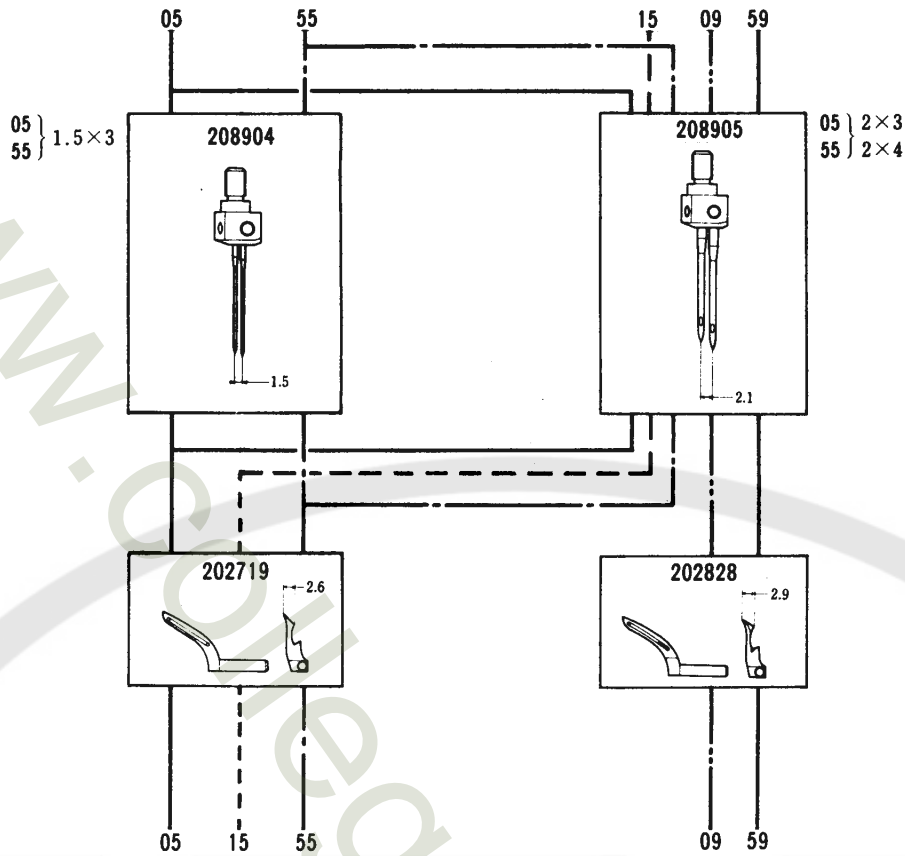

共通パーツ
Common parts

202703

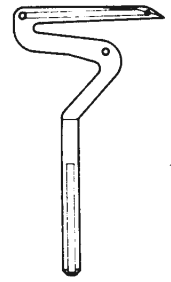

201454B



202749



205258



202295



主送り
Main Feed

12



6

差動送り
Diff. Feed

10



10

R53-15





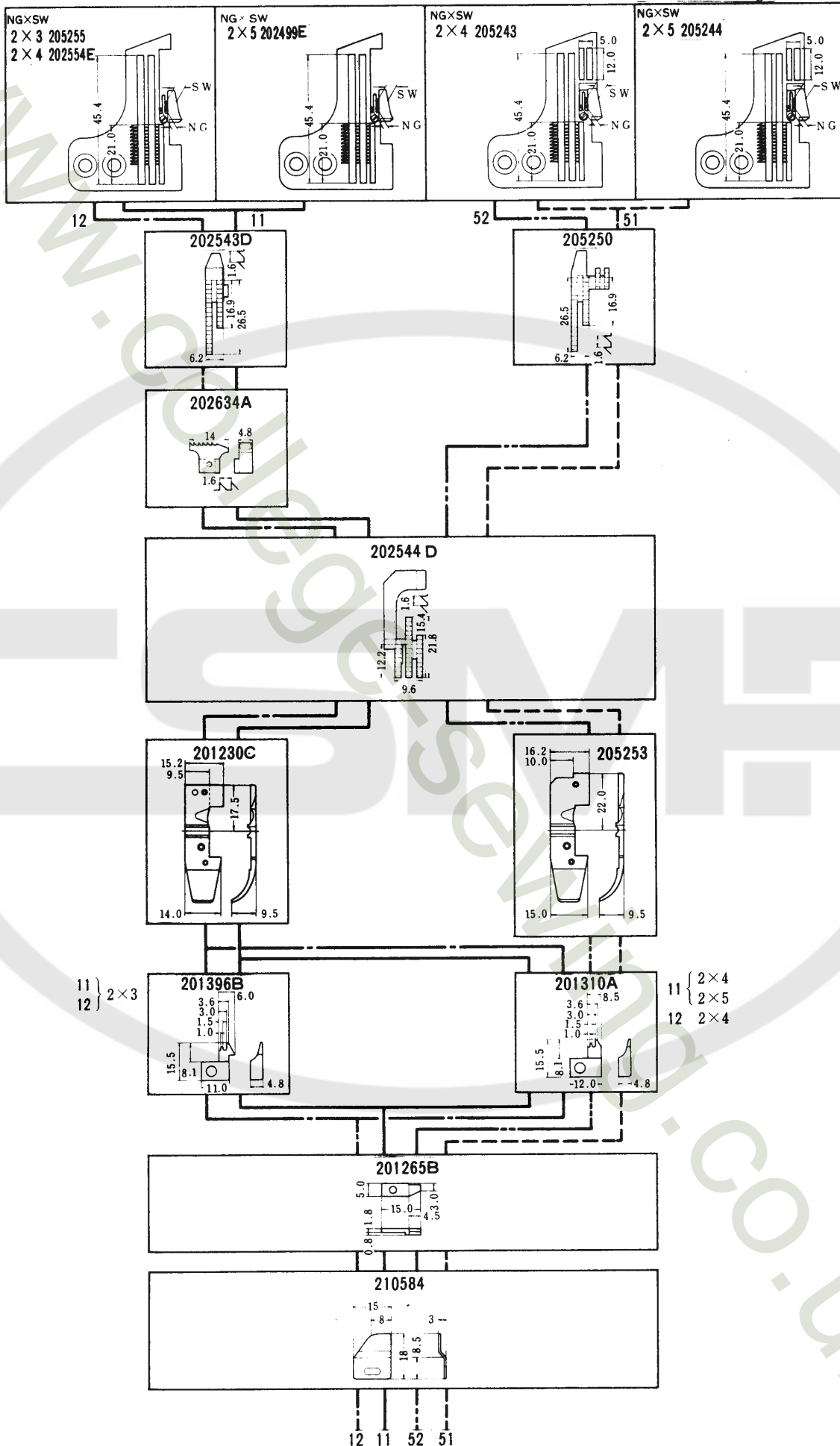

R53-05	1.5 2	3 3,4	514	8-14	薄生地、中厚生地の地縫 (メリヤス肌着、婦人子供服)	Two needle machines for closing and attaching sleeves and side closing on light to medium weight materials.
R53-09	2	3,4	512	8-14	薄生地、中厚生地の地縫 (カッターシャツ、ブラウス、ワンピース)	Closing and attaching sleeves and side closing on dress shirts.
R53-15	2	3,4	514	6-12	毛編物の地縫 (セーター、カーディガン)	Specially designed for seaming bulky knit materials such as sweaters, cardigans etc.
R53-55	1.5 2	3 3,4	514	8-14	薄生地、中厚生地の地縫 (メリヤス肌着、U首シャツ、ランニング、スリーマー)	Two needle machines for closing and attaching sleeves and side closing on light to medium weight materials.
R53-59	2	3,4	512	8-14	薄生地、中厚生地の地縫 (水着、ガードル、セーター、カッターシャツ)	Closing and attaching sleeves and side closing on dress shirts.
R53-85	1.5 2	3 3,4	514	8-14	合織の薄生地、中厚生地の地縫 ● HR装置付 (水着、スラックス)	Same as R53-05, but with needle cooler and thread lubricator (HR device)
R53-89	2	3,4	512	8-14	合織の薄生地、中厚生地の地縫 ● HR装置付 (水着、ドレス、ブラウス、カッターシャツ)	Same as R53-09, but with needle cooler and thread lubricator (HR device)

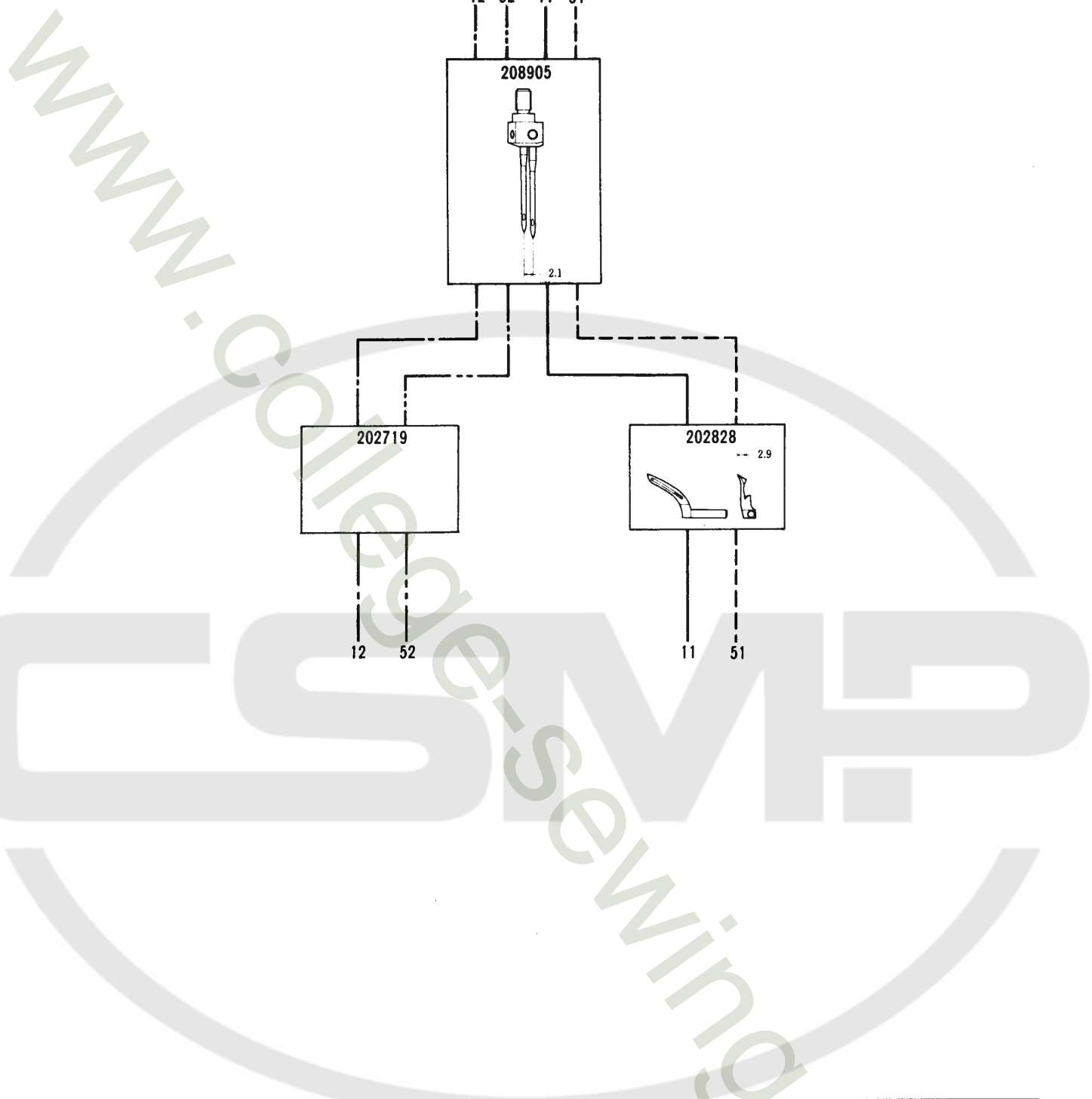
SW = 縫巾
NG = 針巾

SW = Seam Width.
NG = Needle Gauge.





						
R53-11	2	3,4,5	512	8-14	中厚生地の地縫 (水着、作業服、セーター、婦人服)	Closing and attaching sleeves and side closing on dress shirts.
R53-12	2	3,4	514	8-14	中厚生地 of 地縫 (セーター、カーディガン、ガードル、水着)	Two needle machines for closing and attaching sleeves and side closing on light to medium weight materials.
R53-51	2	4,5	512	8-14	中厚生地 of 地縫 (水着、ハジヤマ、作業服、婦人子供服、事務服)	Closing and attaching sleeves and side closing on dress shirts.
R53-52	2	4	514	8-14	薄生地、中厚生地 of 地縫 (セーター、水着、スリーマー)	Two needle machines for closing and attaching sleeves and side closing on light to medium weight materials.

SW = 縫巾
NG = 針巾

SW = Seam Width.
NG = Needle Gauge.

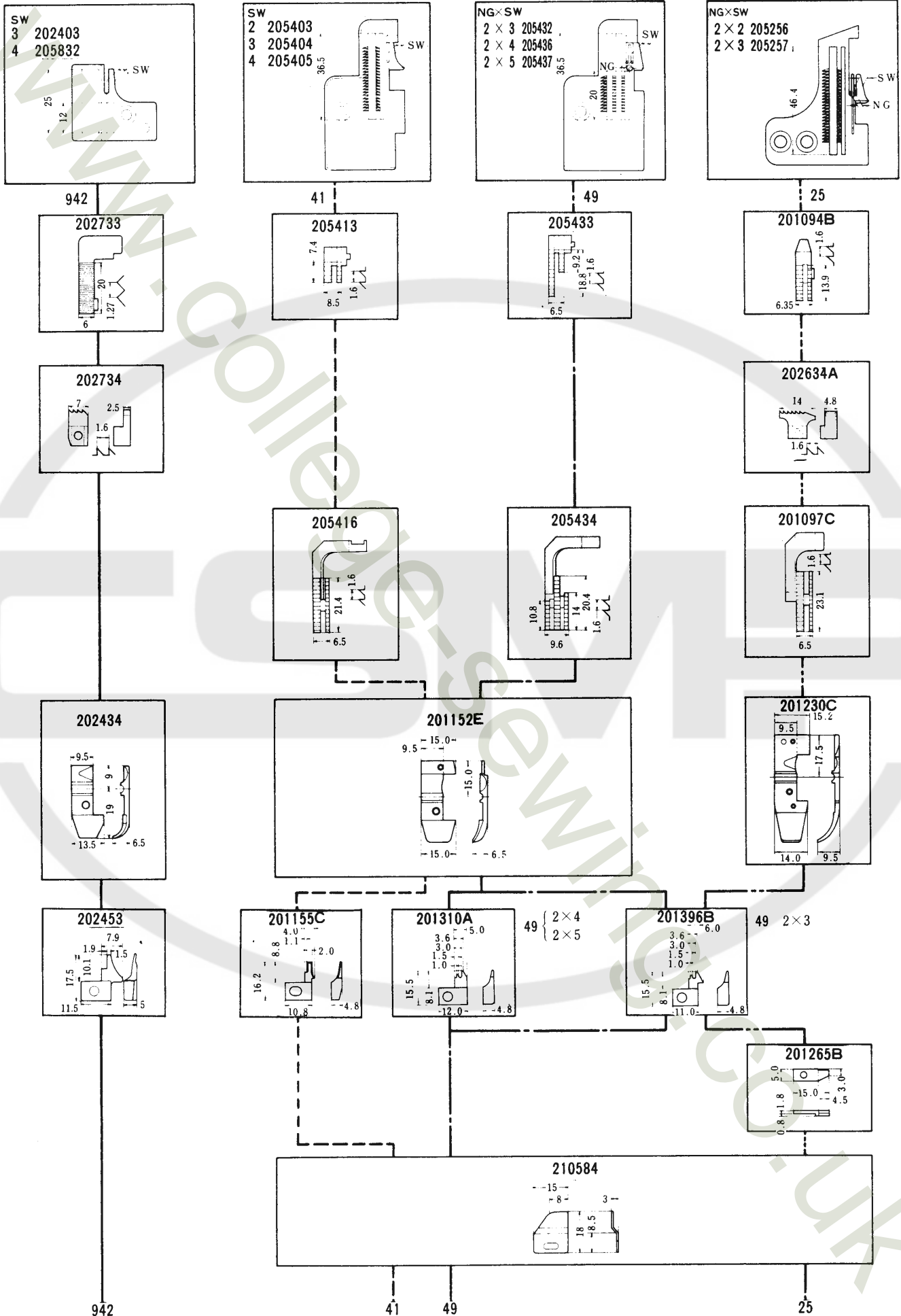

GAUGE PARTS LIST
FOR I-NEEDLE MACHINES

ゲージパーツ表
1本針ミシン用

MACHINE TYPE	GAUGE NG SW タイプ	NEEDLE PLATE	MAIN FEED DOG	AUX. FEED DOG	DIFF. FEED DOG	PRESSER BODY	FINGER	UNCURLER タイプ	FAB.GRD	LOWER KNIFE	UPPER LOOPER	NEEDLE HOLDER	FEED ECC. MAIN DIFF	STITCH TYPE	NDL
R53-01	2	202616	201094B	202634A	201097C	201152E	201155C	210584		202295	202828	204623	12 10	505	DCX1 #9
R53-02	2	202616	201094B	202634A	201097C	201473B	201224B	210584		202295	202828	204623	12 10	504	DCX1 #9
R53-03	3	205320			202854A	202799	201224B	210584	201265B	202295	202840	204623	5.5 5.5	503	DCX1 #14
R53-17	3	202542E	202543D	202634A	202544D	201230C	201224B	210584	201265B	201127	202828	204623	12 10	504	DCX1 #11
R53-53	3	205235	205249		202535C	205252	201224B	210584	201265B	201127	202828	204623	12 10	504	DCX1 #11
R53-54	3	205320	202798		202854A	202799	201224B	210584	201265B	201127	202828	204623	12 10	504	DCX1 #14
R53-54A	3	202684	201094B	202634A	202854A	201230C	201224B	210584	201265B	201127	205891	204623	12 10	504	DCX1 #14
R53-57	3	205324	205250		202544D	205253	201224B	210584	201265B	201127	202828	204623	12 10	504	DCX1 #14
R53-41	2	205403	205413		205416	201152E	201155C	210584		205423	202828	204623	12 10	505	DCX1 #9
DCR-942	3	202403	202733	202734		202434	202453				205891	204623	-- --	504	DCX1 #16

COMMON GAUGE PARTS
FOR THE ABOVE MACHINES

202703	Lower looper	下ルーバー
202408	Lower looper For R53-41, DCR-942 only.	下ルーバー R53-41, DCR-942専用。
201453B	Needle guard (front)	針受 (前)
202474A	Needle guard (rear)	針受 (後)
202490	Needle guard (rear) For DCR-942 only.	針受 (後) DCR-942専用。
201121A	Upper knife	上メス

R53-81 Same gauge parts as R53-01.
ゲージパーツは、R53-01と同じです。

送りエキセンについて

送りエキセンは、ゲージパーツ表中のものをミシンにセットしていただきます。
又、左表のものを付属品に入れていただきます。

機種	付属の エキセン	部品番号	仮番号
R53-03	# 6, # 6	201103B055	#5.5
R53-15	# 8, # 12	201103B060	# 6
その他のR53	# 8, # 14	201103B100	# 8
		201103B120	#10
		201103B140	#12
			#14

なお、ご注文は、右表の部品番号をお使いください。

GAUGE PARTS LIST
FOR 2-NEEDLE MACHINES

ゲージパーツ表
2本針マシン用

MACHINE TYPE	GAUGE NG SW	NEEDLE PLATE	MAIN FEED DOG	AUX. FEED DOG	DIFF. FEED DOG	DIFF. FEED DOG	PRESSER BODY	FOOT FINGER	UNCURLER	FAB.GRD	LOWER KNIFE	UPPER LOOPER	NEEDLE HOLDER	FEED ECC. MAIN	FEED ECC. DIFF	STITCH TYPE	NDL
マシンタイプ	ゲージ	ハリ	シフト	補助	差	圧	足	指	巻き	生地	下	上	針	送り	差	タイプ	
R53-05	1-53	202674	201094B	202634A	202854A	201230C	201396B	210584	201265B	202295	202719	208904	12	10	514	DCX1	ハリ
	2	202702	"	"	"	"	201310A	"	"	"	"	#6	208905	"	"	DCX1	#9
	2	202675	"	"	"	"	201310A	"	"	"	"	"	"	"	"	DCX1	#9
R53-12	2	205255	202543D	202634A	202544D	201230C	201396B	210584	201265B	202295	202719	208905	12	10	514	DCX1	#11
	2	202554E	"	"	"	"	201310A	"	"	"	"	#6	"	"	"	DCX1	#11
R53-15	2	202702	201094B	202634A	202854A	201230C	201396B	210584	201265B	202295	202719	208905	6	10	514	DCX1	#14
	2	202675	"	"	"	"	201310A	"	"	"	"	#6	"	"	"	DCX1	#14
R53-25	2	205256	201094B	202634A	201097C	201230C	201396B	210584	201265B	202295	202719	208905	12	10	514	DCX1	#9
	2	205257	"	"	"	"	"	"	"	"	"	#6	"	"	"	DCX1	#9
R53-52	2	205243	205250	-----	202544D	205253	201310A	210584	201265B	202295	202719	208905	12	10	514	DCX1	#9
	2	202981	202798	-----	202854A	202799	201396B	210584	201265B	202295	202719	208904	12	10	514	DCX1	#9
	2	202982	"	-----	"	"	"	"	"	"	"	#6	208905	"	"	DCX1	#9
	2	202983	"	-----	"	"	201310A	"	"	"	"	"	"	"	"	DCX1	#9
R53-09	2	202702	201094B	202634A	202854A	201230C	201396B	210584	201265B	201127	202828	208905	12	10	512	DCX1	#11
	2	202675	"	"	"	"	201310A	"	"	"	"	#4	"	"	"	DCX1	#11
R53-11	2	205255	202543D	202634A	202544D	201230C	201396B	210584	201265B	202295	202828	208905	12	10	512	DCX1	#14
	2	202554E	"	"	"	"	201310A	"	"	"	"	#4	"	"	"	DCX1	#14
	2	202499E	"	"	"	"	"	"	"	"	"	"	"	"	"	DCX1	#14
R53-51	2	205243	205250	-----	202544D	205253	201310A	210584	201265B	202295	202828	208905	12	10	512	DCX1	#14
	2	205244	"	-----	"	"	"	"	"	"	"	#4	"	"	"	DCX1	#14
R53-59	2	202982	202798	-----	202854A	202799	201396B	210584	201265B	202295	202828	208905	12	10	512	DCX1	#11
	2	202983	"	-----	"	"	201310A	"	"	"	"	#4	"	"	"	DCX1	#11
R53-45	2	205432	205433	-----	205434	201152E	201396B	210584	-----	205423	202719	208905	12	10	514	DCX1	#9
	2	205436	"	-----	"	"	201310A	"	-----	"	"	#6	"	"	"	DCX1	#9
R53-49	2	205432	205433	-----	205434	201152E	201396B	210584	-----	205423	202828	208905	12	10	512	DCX1	#11
	2	205436	"	-----	"	"	201310A	"	-----	"	"	#4	"	"	"	DCX1	#11
	2	205437	"	-----	"	"	"	"	-----	"	"	"	"	"	"	DCX1	#11

R53-85	Same gauge parts as R53-05. ゲージパーツは、R53-05と同じです。	針 (needle) DC×1
R53-89	Same gauge parts as R53-09. ゲージパーツは、R53-09と同じです。	#11

FEED ECCENTRIC

When shipped, the individual machines have the Feed Eccentrics as shown on the Gauge Parts List. The following Feed Eccentrics are additionally put in the Accessory Can.

Machine	Feed Eccentric in Accessory Can	I. D.
R53-03	#6, #6	Part No. No. 201103B055 #5.5 201103B060 #6 201103B080 #8 201103B100 #10 201103B120 #12 201103B140 #14
R53-15	#8, #12	
Other R53	#8, #14	

When placing orders for Feed Eccentrics, please specify the PART NUMBER in the right list.

COMMON GAUGE PARTS
FOR THE ABOVE MACHINES

202703	Lower looper	下ルーパー
202408	Lower looper For R53-45-49 only.	下ルーパー R53-45-49専用。
201454B	Needle guard (front)	針受 (前)
202749	Needle guard (rear) (movable type)	針受 (後) (移動式)
205258	Upper knife	上メス
202688A	Needle guard (rear) R53-49	針受 (後)

上記機種の
共通ゲージパーツ

SPECIFIC PARTS LIST

専用部品表

MACHINE TYPE	TYPE PLATE	NEEDLE BAR CRANK (REAR)	NDL THREAD TEN.SPRING	MAIN FEED LINK BUSH.	CLOTH PLATE FAB. GUARD
機 種	形 式 板	針 棒 クランク(後)	針 糸 調子バネ	主送リリンク ブッシュ	衣 除 ケ
R53-01	212799	201360B	201037	201099	202651A
02	"	"	"	"	"
03	"	"	201086	201154	202796
17	"	"	201037	201099	202651A
53	"	"	"	"	202796
54	"	"	"	"	"
57	"	"	"	"	"
81	"	"	"	"	202651A
05	"	"	"	"	"
12	"	"	"	"	"
15	"	201441B	"	201154	"
25	"	201360B	"	201099	"
52	"	"	"	"	202796
55	"	"	"	"	"
09	"	201441B	"	"	202651A
11	"	"	"	"	"
51	"	"	"	"	202796
59	"	"	"	"	"
85	"	201360B	"	"	202651A
89	"	201441B	"	"	"
41	"	201360B	"	"	205518
49	"	201441B	"	"	"
DCR-942	"	"	201068	202309	-----

MACHINE	NDL THREAD TEN. GUIDE	LOWER LOOPER HOLDER	FRONT COVER (LEFT)	UPR LOOPER HLDR COVER	UPR LOOPER THREAD GUIDE	LWR LOOPER CON.GUIDE
機 種	針 糸 調子台	下ルーバー台	前カバー(左)	上ルーバー台 カバー	上ルーバー 糸道	下ルーバー ロッド振止
1-needle R53 R53・1本針	205770	201438A	* 202680	202937	-----	201074A
2-needle R53 R53・2本針	201243A	202728	** 202755	205296	205295	202790
R53-41	205770	205409	205398	205400	205441	201074A
R53-49	201243A	"	"	"	"	202790
DCR-942	205770	202736	"	"	"	201074A

*202750 for R53-81 R53-81用
 **202741 for R53-85,89 R53-85,89用

PART NUMBER INDEX

部品番号インデックス

PART NO.	PAGE	REF. NO.	PART NO.	PAGE	REF. NO.	PART NO.	PAGE	REF. NO.	PART NO.	PAGE	REF. NO.	PART NO.	PAGE	REF. NO.
DCX1	11	39	1196	29	50	4009-1	7	40	5164	29	23	201002	3	4
DCX1	37	5	1202	7	6	4009-1	15	16	5184	33	17	201002	3	8
DCX3	11	40	1202	13	26	4009-1	15	38	5184	35	19	201004	3	27
126	37	17	1202	19	39	4009-1	27	27	5185	11	2	201009	9	11
127	37	12	1202	21	24	4009-1	33	9	5187	27	2	201009	9	17
128	37	13	1202	21	29	4009-1	33	20	5198	3	14	201009	31	9
129	37	14	1202	21	34	4009-1HC	13	2	5208B	31	63	201010A	9	25
130A	37	21	1202	23	29	4012	57	24	5213	21	56	201017A	9	42
131	37	15	1202	35	16	4012	57	28	5219	17	31	201034A	13	3
132	37	3	1202	35	22	4014	57	21	5220	17	38	201037	15	4
152	37	11	1206	5	20	4021	57	17	5233	11	4	201048A	17	1
153	37	16	1216	5	23	4022	57	35	5234	11	6	201048A	17	2
154	37	23	1216	5	26	4513	55	7	5237	3	6	201048A	19	1
178	37	25	1216	5	35	4803	57	8	5260	27	35	201048A	19	2
179	37	22	1216	5	39	4803	57	22	5261	31	48	201068	15	13
200	37	10	1216	5	41	4803	57	25	5274	19	31	201068	17	7
233-JA	57	23	1216	5	43	4803	57	29	5292	11	20	201073B	19	13
272	37	24	1216	5	47	4805	57	18	5292	11	38	201074A	19	16
282	37	6	1216	5	53	4904	55	11	5292	25	28	201075	19	20
283	37	7	1216	7	5	4905	55	15	5293	7	15	201079A	19	22
284	37	8	1216	7	17	4909	37	31	5299	15	36	201080	19	24
286	37	9	1216	7	24	5002	17	14	5299	35	11	201086	15	11
293B	57	26	1216	25	13	5002	19	14	5305	17	42	201086	19	7
293C	57	27	1216	33	5	5002	23	6	5312	11	16	201088	19	38
380A	57	6	1216	35	29	5003	23	31	5328	11	13	201089	17	55
382-JA	57	11	1227	23	19	5010	9	46	5328	17	59	201092A	13	5
383-JA	57	19	1231	17	47	5012	33	11	5328	19	34	201093A	21	22
384	57	20	1231	29	48	5020	31	51	5328	21	4	201094B	48	
386	57	36	1234	5	6	5029	29	19	5328	27	10	201094B	49	
4022	57	14	1234	7	45	5030	29	45	5328-HC	13	19	201096A	21	27
452	37	2	1326	7	33	5048	19	21	5345	29	35	201096A	23	27
478	37	18	1435	7	20	5048	19	23	5359	15	31	201097C	48	
482	37	19	1435	7	21	5053	11	31	5364	13	31	201097C	49	
484	37	4	1435	21	10	5053	13	4	5373	17	20	201099	21	42
486B91	57		1435	23	12	5053	29	15	5381	11	9	201099	21	48
486C91	57		1457	11	25	5060	9	26	5381	13	14	201100	21	44
502-JA	57	15	1457	25	5	5060	9	28	5381	27	6	201100	21	50
503-JA	57	1	1457	25	7	5060	31	13	5422	7	42	201101	21	47
504-JA	57	16	1458	9	41	5064	17	54	5434	7	28	201103B	37	20
505-JA	57	4	1458	23	4	5078	3	3	5441	31	58	201103B055	48	
505-JA	57	30	1458	31	11	5080	9	43	5476	57	3	201103B055	49	
505AJA	57	5	1459	17	3	5081	17	44	5519	17	56	201103B060	48	
505AJA	57	31	1459	19	3	5082A	15	8	5519	19	41	201103B060	49	
506	57	32	1732	13	11	5082A	17	11	7102	57	12	201103B080	48	
507	57	10	1732	15	19	5082A	19	11	7102	57	33	201103B080	49	
509	57	2	1892	9	15	5084	17	16	9050	55	12	201103B100	48	
512	57	13	2022	21	21	5084	17	19	9070-2	15	34	201103B100	49	
512	57	34	2022	27	21	5084	23	9	137142	35	9	201103B120	48	
908	37	1	2022	29	31	5084	27	4	137906	5	16	201103B120	49	
1156	13	21	2022-3	21	2	5084	29	27	137906	25	12	201103B140	48	
1156	19	19	2022-3	23	23	5086	21	26	137906	35	23	201103B140	49	
1156	31	25	2022-3	29	3	5088	27	16	137906	35	26	201106	21	30
1170-1	19	15	2022-4	11	17	5089	29	43	137906	35	30	201107	23	33
1170-3	11	23	2022-4	17	23	5091	23	16	167066	21	8	201109	21	5
1174	25	2	2022-4	29	30	5092	25	22	167066	23	26	201110	21	9
1175-2	3	19	2193	33	6	5095	5	2	198192	5	10	201110	23	11
1175-2	9	2	2213-1	7	30	5095	7	9	200030	11	26	201115A	11	11
1175-2	9	13	2213-1	23	2	5095	17	40	200041	15	32	201115A	27	7
1175-2	9	20	2213-1	31	2	5095	21	14	200098	21	46	201117	11	12
1175-2	9	33	2237	23	40	5095	23	21	200098	21	53	201117	27	9
1175-2	13	6	2905	5	36	5095	31	37	200098	23	38	201121A	27	14
1175-2	13	16	2905	35	8	5097	29	9	200098	23	43	201121A	48	
1175-2	13	24	2921	5	29	5099	7	12	200136	31	26	201125	27	22
1175-2	21	37	2921	19	37	5113	31	66	200136	31	43	201127	27	24
1175-2	27	19	2921	29	37	5117	3	13	200137	31	44	201127	37	26
1175-2	31	16	2928	25	17	5117	3	22	200138	31	67	201127	48	
1175-2	35	2	3044	7	22	5117	7	47	200152	31	27	201127	49	
1175-3	5	14	3044	21	45	5117	7	49	200155	33	24	201129	27	28
1175-3	13	8	3044	21	52	5117	15	28	200159A	7	8	201130A	27	29
1175-3	13	34	3044	23	37	5117	31	5	200162A	7	18	201131A	27	31
1175-3	21	7	3044	23	44	5117	33	15	200163A	7	19	201132B	27	34
1175-3	23	25	3044	25	10	5137	15	15	200174	23	15	201134	27	36
1175-3	27	30	3044	29	10	5137	15	18	200183	7	10	201139	23	8
1175-3	27	33	3044	35	20	5138B	31	55	200205	15	33	201141	29	24
1175-3	31	42	3091	5	15	5142	7	38	200555	15	26	201152E	29	38
1175-3	35	25	3091	35	27	5142	29	8	200633	33	13	201152E	48	
1186	13	36	3119	11	34	5146	17	36	200633	33	22	201152E	49	
1189	3	29				5149A	9	40	200654	11	19	201154	21	43
1189	27	13	4009-1	5	8	5150B	31	62	200821	7	13	201155C	29	39
1196	21	18	4009-1	5	18	5163	3	7	200821	25	16	201155C	48	

PART NUMBER INDEX

部品番号インデックス

PART NO.	PAGE	REF. NO.	PART NO.	PAGE	REF. NO.	PART NO.	PAGE	REF. NO.	PART NO.	PAGE	REF. NO.	PART NO.	PAGE	REF. NO.
201156	29	42	202174	17	52	202476-2	33	2	202734	23	30	205248		48
201160B	29	1	202175	9	16	202476-3	33	3	202734	48		205249		48
201161	29	2	202175	17	48	202476-4	33	4	202736	19	30	205250		48
201162A	29	4	202175	21	41	202490	13	23	202737	31	65	205250		49
201164A	29	29	202176	11	21	202490	48		202739	27	26	205252		48
201167A	29	7	202176	17	32	202491	13	32	202741	5	33	205253		48
201181C	7	2	202176	17	35	202495	15	30	202745A	33	19	205253		49
201184	7	4	202176	21	16	202526	3	25	202749	13	35	205255		49
201185	7	7	202176	23	13	202535C	48		202749	49		205256		49
201185	25	9	202177	17	28	202542E	48		202750	5	31	205257		49
201186	7	16	202181	21	11	202543D	48		202755	5	32	205258	27	15
201191	5	50	202193	31	30	202543D	49		202756	29	26	205258		49
201191	33	18	202199	31	29	202544D	48		202757A	17	21	205261	9	10
201191	35	18	202199	31	46	202544D	49		202775	31	49	205292	27	11
201200-FD	5	21	202200	21	19	202546E	48		202776	31	50	205294	31	31
201201	5	22	202201A	21	12	202554E	49		202777	31	41	205295	17	60
201202	5	24	202202	21	15	202559	48		202781	23	41	205296	5	58
201203	5	25	202203	21	17	202589	29	28	202790	19	17	205319	35	31
201206A	35	1	202286	17	43	202596E	48		202794	31	38	205320		48
201211B	35	3	202286	19	18	202597E	48		202796	5	45	205321		48
201212D	9	24	202286	31	59	202605	11	3	202798	48		205322		48
201221A	7	11	202287A	31	56	202606	11	14	202798	49		205323		48
201224B	48		202295	27	23	202616	48		202799	48		205324		48
201230C	49		202295	37	27	202617	48		202799	49		205325		48
201233A	35	21	202295	48		202618	48		202827	17	33	205326		48
201243A	15	17	202295	49		202619A	17	13	202828	48		205378	31	1
201252	13	9	202309	23	35	202622B	17	27	202828	49		205382	7	23
201252	57	7	202310	23	36	202623A	17	24	202840	48		205383	7	37
201265B	29	47	202354	3	16	202625	17	34	202849	17	12	205387	7	25
201265B	48		202355	3	31	202626A	17	30	202849	19	12	205388-FD	7	26
201265B	49		202355	3	34	202631A	17	53	202854A	48		205389	7	27
201288A	31	3	202395A	23	39	202633	19	35	202854A	49		205390	7	29
201293A	31	4	202403	13	17	202634A	48		202864	9	22	205391	7	31
201297	31	10	202404	13	20	202634A	49		202865	7	14	205392	7	32
201298	9	27	202405	13	22	202636	27	20	202868	29	5	205393	7	34
201299	31	12	202408	19	33	202637B	27	18	202875	17	57	205394	7	35
201300A	31	17	202408	48		202638B	27	12	202875	19	42	205395	7	36
201300A	31	22	202408	49		202639	29	22	202901	9	6	205396	7	39
201301	31	18	202412	23	1	202640A	29	25	202902	9	5	205398	5	34
201301	31	23	202413	23	10	202641	29	13	202902	9	29	205399	5	28
201303	31	21	202414A	23	7	202642	29	14	202903	9	7	205400	5	40
201303	31	32	202416	23	5	202645	29	21	202905	9	32	205401	9	18
201304	31	20	202417	23	34	202647A	29	17	202907	9	4	205402A	9	12
201310A	49		202418	23	42	202648C	3	11	202908	9	3	205403		48
201319A	31	19	202420B	23	22	202649A	3	12	202914	17	44	205404		48
201328	31	39	202422	23	24	202651A	5	44	202915	17	45	205405		48
201329	31	40	202423	25	14	202653	5	4	202916	17	46	205406	13	12
201330	3	20	202425	25	4	202660	5	27	202917	17	41	205407	13	15
201335	31	60	202426	25	3	202662	3	17	202919	17	49	205408	17	39
201338	31	14	202427	25	6	202663D	3	18	202920	17	50	205409	19	29
201341	31	15	202428	25	11	202669	48		202921	17	51	205410	21	32
201356A	11	10	202429	25	15	202674	49		202922	17	25	205413		48
201360B	11	7	202430	25	18	202675	49		202923	19	26	205414	21	35
201381A	27	5	202431-1	25	23	202680	5	30	202924	21	57	205416		48
201395	29	20	202431-2	25	24	202682A	29	49	202925	27	1	205417	21	38
201396B	49		202431-2	37	33	202683	29	34	202927	27	8	205417	23	32
201404	5	7	202431-3	25	25	202684	48		202928	31	24	205418	21	39
201422B	31	35	202431-3	37	32	202685	48		202929	31	33	205419	21	20
201423	31	36	202431-4	25	26	202686B-HD	5	1	202930	31	34	205420	21	6
201424A	31	47	202431-4	37	34	202687	3	15	202937	5	37	205421A	21	3
201426A	31	45	202433	25	21	202688A	13	28	202940	9	1	205422	21	13
201438A	19	27	202434	29	40	202688A	49		202941B	21	1	205423	27	25
201441B	11	8	202434	48		202689	5	5	202942	5	42	205423	37	28
201453	13	29	202437	13	25	202702	49		202981	49		205424	27	32
201453B	48		202438	25	1	202703	19	32	202982	49		205432		49
201454B	13	30	202439-FD	7	48	202703	48		202983	49		205433		49
201454B	49		202442	25	19	202703	49		202990	9	8	205434		49
201473B	48		202449	25	20	202705A	15	29	202999	11	1	205436		49
201479	37	30	202451	29	36	202706A	15	35	204273	9	21	205437		49
201480	37	29	202453	48		202709A	17	17	204623	11	33	205440	31	61
201482	15	6	202453A	29	41	202710A	17	22	204623	48		205441	17	58
201482	17	9	202455	33	14	202712A	17	18	204625A	11	27	205448	9	14
201482	19	9	202456	33	16	202716	3	2	204627	11	28	205457	35	4
201485	35	17	202461	33	7	202719	49		204806	31	64	205466	55	8
201500	35	14	202466	7	1	202724	13	33	205235	48		205467	55	3
201809	19	40	202467-FD	7	3	202728	19	28	205236	48		205468-JA	55	13
202030A	33	12	202472	33	21	202730	9	23	205237	48		205469-JA	55	14
202081	9	9	202474A	13	27	202732	19	36	205238	48		205470-JA	55	10
202081	17	29	202474A	48		202733	23	28	205243	49		205471	9	45
202132A	35	15	202476-1	33	1	202733	48		205244	49		205473	55	9

PART NUMBER INDEX

部品番号インデックス

PART NO.	PAGE	REF. NO.	PART NO.	PAGE	REF. NO.	PART NO.	PAGE	REF. NO.	PART NO.	PAGE	REF. NO.
205479	13	7	208449	15	7						
205495	11	5	208449	17	10						
205495	17	15	208449	19	10						
205495	23	3	208450	15	5						
205495	27	3	208450	17	8						
205518	5	46	208450	19	8						
205526	9	30	208487	33	10						
205544	5	49	208488	15	1						
205545	5	51	208488	15	9						
205678	35	5	208489	15	10						
205679	35	6	208489	19	4						
205685	5	12	208490	15	12						
205689-FD	3	1	208490	17	4						
205690-FD	3	5	208560	15	21						
205691	3	9	208561	15	22						
205692	3	10	208562	15	23						
205693-FD	3	21	208563	15	24						
205694	5	3	208568	15	20						
205697	11	30	208598	29	16						
205698	9	38	208599	29	18						
205700	9	31	208617	11	32						
205701	9	34	208621	11	24						
205702	29	6	208713	15	25						
205703	15	27	208725	5	9						
205704	29	32	208744	5	13						
205705	29	33	208747	5	11						
205708	3	28	208773	29	12						
205711	9	39	208777	15	37						
205713	9	36	208903	11	35						
205714	5	48	208904	11	36						
205719	29	11	208904	49							
205720	9	35	208905	11	37						
205763	31	28	208905	49							
205764	55	5	208915	35	24						
205765	55	6	208916	35	28						
205767	5	19	209150	31	57						
205768	31	53	210125	17	26						
205770	15	14	210584	29	44						
205771	17	61	210584	48							
205778	19	25	210584	49							
205828	3	26	210585	29	46						
205829	3	30	210679	3	24						
205830	3	33	210766	33	23						
205832	13	18	211301	7	43						
205832	48		211376	27	17						
205833	31	52	212186	11	29						
205835	35	10	212279	3	23						
205836-FD	7	41	212279	3	32						
205840	7	44	212279	3	35						
205841	7	46	303312A	35	12						
205842	23	14	303313	35	13						
205843	23	17	305456	35	7						
205844	23	18									
205845	23	20									
205846	9	19									
205850	21	40									
205857	21	31									
205859	5	52									
205887	31	6									
205891	48										
205892	25	8									
205893	25	27									
206119	21	49									
206120	21	51									
206215	13	13									
206336	55	1									
206337	55	2									
206337	55	4									
208272	9	37									
208424	11	15									
208425	11	18									
208427	11	22									
208430	5	17									
208446	33	8									
208447	15	2									
208447	17	5									
208447	19	5									
208448	15	3									
208448	17	6									
208448	19	6									

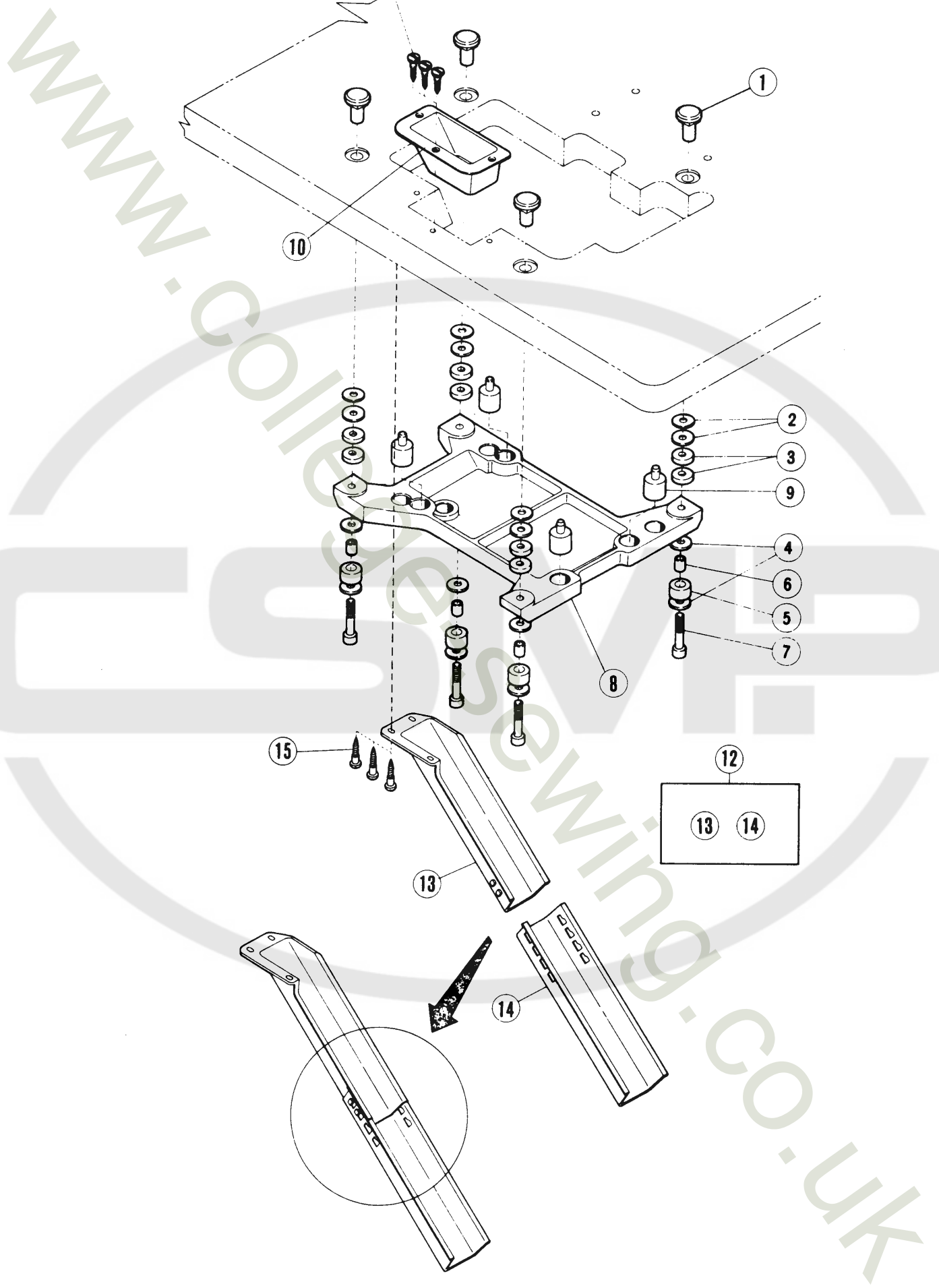

半沈床式据付付属品

SEMI-SUBMERGED INSTALLATION PARTS

REF. PART NO. NO.	フマハツ メシヨウ	NAME	QT.	
1	206336	マルナツト	NUT	4
2	206337	サカカネ	WASHER	8
3	205467	スヘーサー(タイ)	SPACER	8
4	206337	サカカネ	WASHER	4
5	205764	ホウシンゴム	RUBBER	4
6	205765	ライナー	LINER	4
7	4513	ホルト/M8	HANGER BOLT	4
8	205466	マシンエツケイタ	MACHINE REST BOARD	4
9	205473	ホウシンゴム	CUSHION RUBBER	4
10	205470-JA	キルクスウケC	WASTE CHUTE TOP	1
11	4904	サラネシ	SCREW	3
12	9050	キルクスウケA・B(クミ)	WASTE CHUTE SET	1
13	205468-JA	キルクスウケA	WASTE CHUTE	1
14	205469-JA	キルクスウケB	WASTE CHUTE EXTENSION	1
15	4905	ヒラネシ	SCREW	3

WWW.

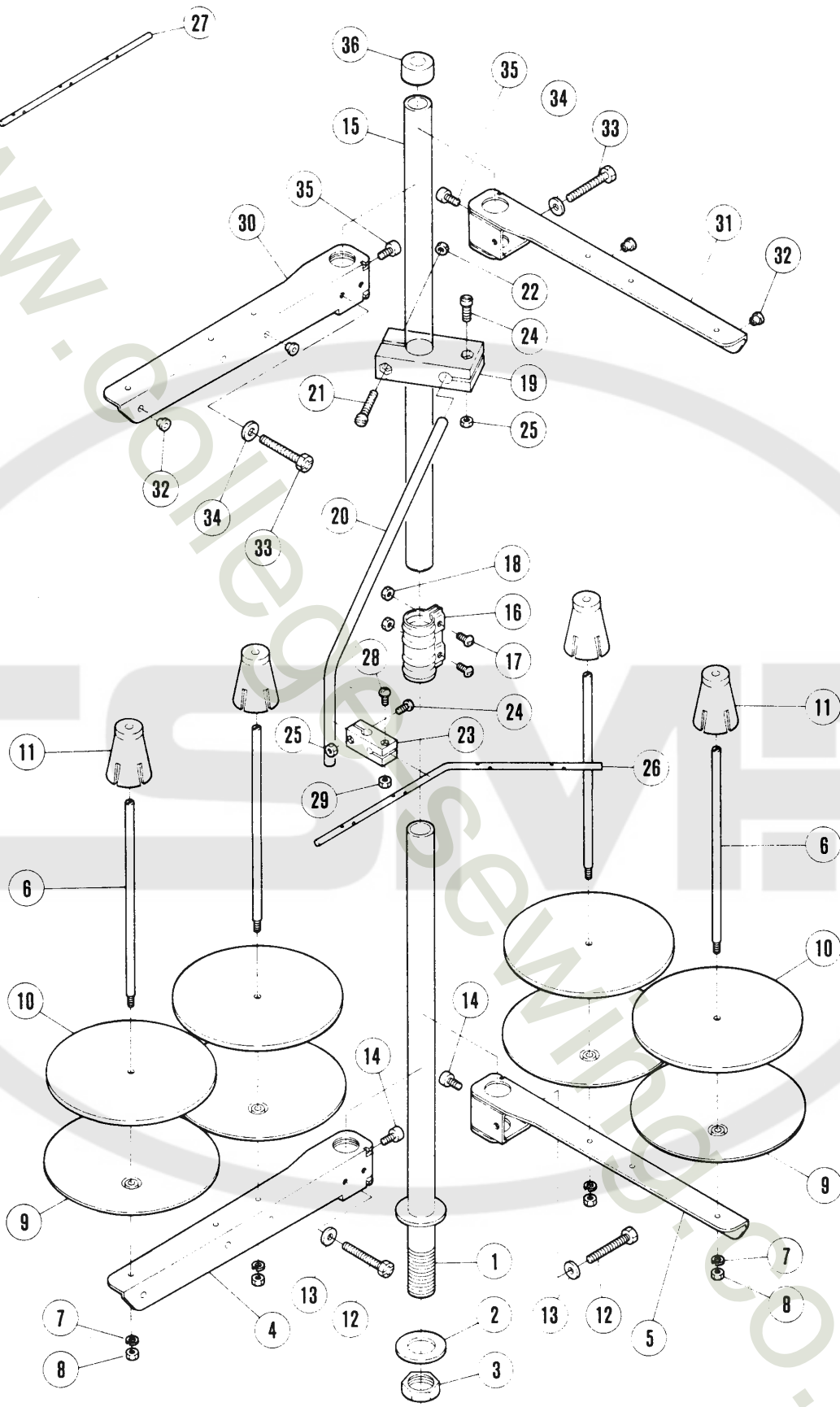

REF. NO.	PART NO.	名 称	NAME	3-spools 3本立	4-spools 4本立
	486C9C	糸立(組)(3本立)	THREAD STAND ASSEMBLY	1	
	486B9C	糸立(組)(4本立)	THREAD STAND ASSEMBLY		1
1	503-CA	スタンド棒(下)	THEAD STAND ROD	1	1
2	509	座金	WASHER	1	1
3	5476	六角ナット	NUT	1	1
4	505-CA	ブラケット(3本立)	BRACKET	1	
5	505ACA	ブラケット(2本立)	BRACKET		2
6	380A	糸立棒	SPOOL PIN	3	4
7	201252	パネ座金	WASHER	3	4
8	4803	六角ナット M 4	NUT	3	4
9	381-CA	受皿	SPOOL TRAY	3	4
10	507	ウレタン	CUSHION	3	4
11	382-CA	ユレ止め	SPPOOL RETAINING FIN	3	4
12	7102	六角ネジ M 6	SCREW	1	2
13	512	座金	WASHER	1	2
14	4022	平ネジ M 6	SCREW	1	2
15	502-CA	スタンド棒(上)	THREAD STAND ROD	1	1
16	504-CA	ジョイント	JOINT	1	1
17	4021	平ネジ M 5	SCREW	2	2
18	4805	六角ナット M 5	NUT	2	2
19	383-CA	ブラケット	BRACKET	1	1
20	384	糸道棒腕	THREAD GUIDE BAR ROD	1	1
21	4014	平ネジ M 4	SCREW	1	1
22	4803	六角ナット M 4	NUT	1	1
23	233-CA	ホルダー	HOLDER	1	1
24	4012	平ネジ M 4	SCREW	2	2
25	4803	六角ナット M 4	NUT	2	2
26	293C	糸道棒	THREAD GUIDE BAR	1	
27	293B	糸道棒	THREAD GUIDE BAR		1
28	4012	平ネジ M 4	SCREW	1	1
29	4803	六角ナット M 4	NUT	1	1
30	505-CA	ブラケット(3本立)	BRACKET	1	
31	505ACA	ブラケット(2本立)	BRACKET		2
32	506	糸目穴	THREAD EYELET	3	4
33	7102	六角ネジ M 6	SCREW	1	2
34	512	座金	WASHER	1	2
35	4022	平ネジ M 6	SCREW	1	2
36	386	キャップ	ROD CAP	1	1

**■ PEGASUS
SEWING MACHINE MFG.
CO., LTD.®**



First edition December, 1970.
Second edition December, 1976 (12762T500).
Third edition November, 1980 (111T404).(D)