

*Revolutionize Production through
worker creativity by pegasus!*

EXT SERIES

EXT3200 Series 差動上下送り安全縫いミシン
Variable top feed safety stitch machines

EXT5200 Series 差動上下送りオーバーロックミシン
Variable top feed overedgers

専用部品パーツカタログ
Specific parts Catalog



PEGASUS®

パーツカタログの見方

■このパーツカタログは、1992年5月製造中のEXT3200・5200シリーズミシンの専用部品のみを次の要領で編集しています。

※専用部品以外の部品は、EX3200・5200シリーズと同じ部品を使用しています。EXシリーズパーツブックをご覧ください。(Cat. No. 9605)

■2~31頁には部品を機構別に収録し、左頁が部品の分解図、右頁がパーツリストになっています。

また、部品分解図に付されている番号は、パーツリストのREF. NO.(参照番号)を示しています。

■ゲージパーツ系列構成図・ゲージパーツ表(32~57頁)

これらの部品は、特定の形式にのみ使用されている部品で、系列構成図は32~51頁に、ゲージパーツ表は52~57頁に一括して記載しています。

■58頁以降には部品番号インデックスを記載し、部品番号だけで、その図解、名称などが容易に引き出せます。

■部品を御注文いただくときは、必ず部品番号だけを明示して下さい。

なお、このパーツカタログの記載事項は改良により、予告なく変更されることがありますので、あらかじめご了承ください。

INTRODUCTION

■ This parts catalog contains only special parts for the EXT3200・5200 Series that are in the making as of May, 1992.

※ Since common parts are used between the EX3200・5200 Series and EXT3200・5200 Series, refer to the EX3200・5200 Series parts book (Cat. No. 9605) for parts except special ones.

■ On pages 2~31, each mechanism is arranged on facing pages, the first page containing the illustrations and the second page containing the data of the individual parts.

The number given to each illustrations is the REF. NO. on the parts list.

■ Gauge parts construction charts / gauge parts list.

Gauge parts are used in some machine types and sewing gauges only. Pages 32~51 contain the gauge parts construction charts in order to know the illustrations and the combinations of the parts, and pages 52~57 contain the gauge parts lists to obtain the data at a glance.

■ A part number index is attached to the back of this catalog for convenience.

■ When placing orders for parts from this catalog, use ONLY THE PART NUMBER.

■ This parts catalog is applicable to your machine and is subject to change without notification.

掲載機種 (Models inserted)

EXT3200 Series

(15)
EXT3216-02/223

(15)
EXT3216-03/233

EXT3244-03/333

(15)
EXT3216-04/435K

(15)
EXT3216H-05/535K

EXT3244-04/435K

EXT3244H-05/535K

(15)
EXT3216-42/233

(15)
EXT3216-C3P1/233

(15)
EXT3216-C3P2/233

EXT5200 Series

EXT5204-02/233

EXT5214-03/333

EXT5214-M03/333

EXT5205-12/223

EXT5214-43/333

EXT5214-54S1/433

EXT5214-54S2/433

EXT5214-54S1/443

EXT5214-54S2/443

EXT5214H-55/545

EXT5214-84/433

EXT5214-C3P1/333

EXT5214-C3P2/333

目次

頁

上送り機構(1)~(2).....	2- 7
ベッド,カバー機構.....	8- 9
糸調子機構(糸道,糸繰り関係).....	10- 11
針振り機構.....	12- 13
押エ機構.....	14- 15
給油機構(1)~(2).....	16- 19
専用部品(1)~(5).....	20- 29
当定規.....	30- 31
ゲージパーツ系列構成図.....	32- 51
ゲージパーツ表.....	52- 57
部品番号インデックス.....	58

TABLE OF CONTENTS

Page

TOP FEED MECHANISM(1)~(2).....	2- 7
MACHINE BED FRAME , COVER.....	8- 9
THREAD GUIDE & THREAD TAKEUP.....	10- 11
NEEDLE DRIVE MECHANISM.....	12- 13
PRESSER FOOT MECHANISM.....	14- 15
LUBRICATION MECHANISM(1)~(2).....	16- 19
SPECIFIC PARTS(1)~(5).....	20- 29
FABRIC EDGE GUID.....	30- 31
GAUGE PARTS CONSTRUCTION CHART.....	32- 51
GAUGE PARTS LIST.....	52- 57
PART NUMBER INDEX.....	58

CSMP

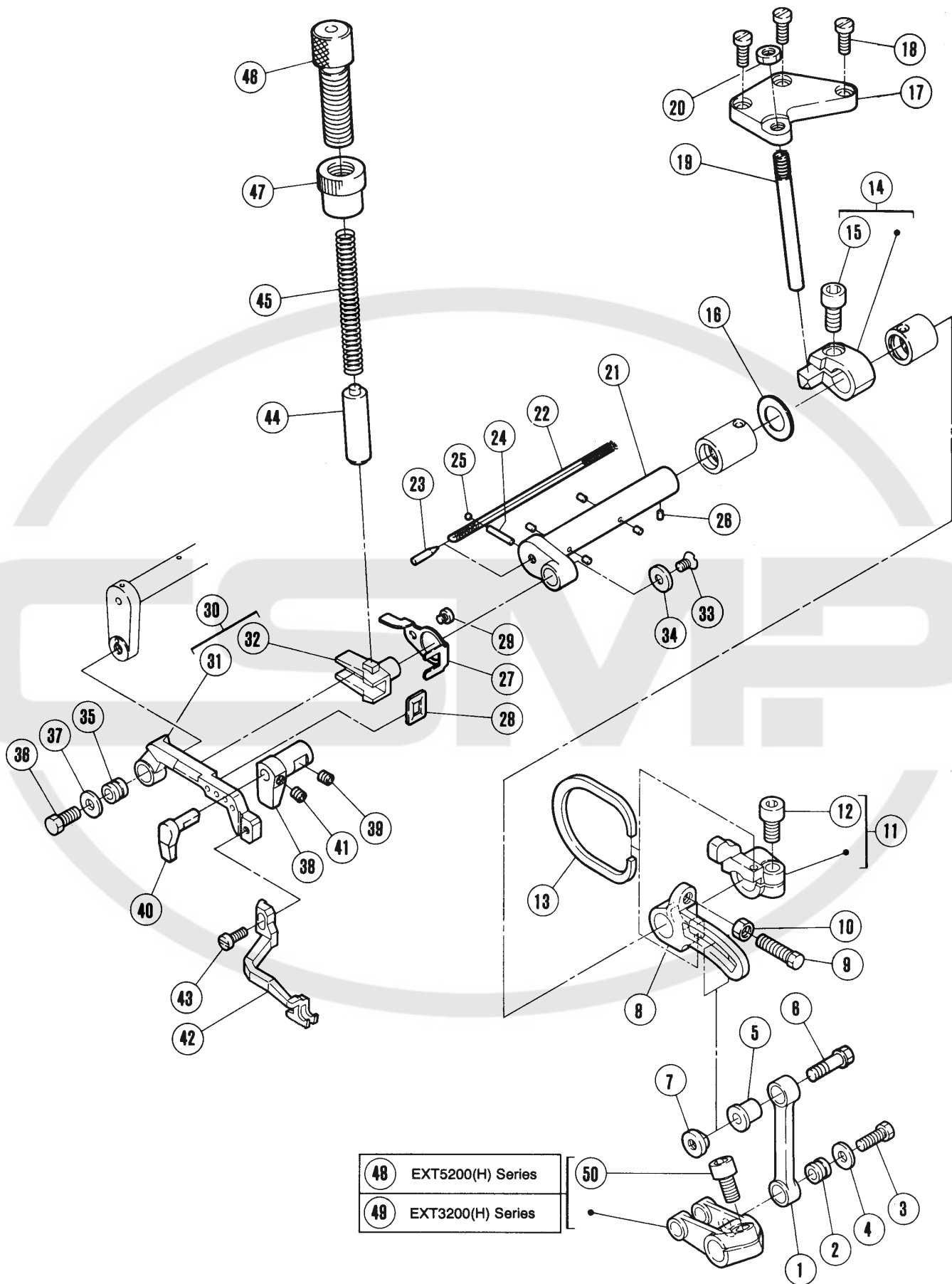

上送り機構(1)

TOP FEED MECHANISM (1)

*=原則販売不可 (Not for sale basically)

REF. NO.	PART NO.	部品番号	名称	NAME	QT.
1	276534		リンク	LINK	1
2	179160-05		ブッシュ	BUSHING	1
3	7056		六角ネジ / M 5 × 1 3	SCREW	1
4	240039		座金	WASHER	1
5	276535		ブッシュ	BUSHING	1
6	7233		六角ボルト	BOLT	1
7	276526		ナット	NUT	1
8	276533		クランク	CRANK	1
9	7206		六角ボルト	BOLT	1
10	7207		六角ナット	NUT	1
11	276536-92		カラー	COLLAR	1
12	4533		平ネジ / M 6 × 1 2	SCREW	1
13	276538		板バネ	FLAT SPRING	1
14	276520-92		カラー	COLLAR	1
15	4534		平ネジ / M 6 × 1 4	SCREW	1
16	208235		座金	WASHER	1
17	276521		ブラケット	BRACKET	1
18	7021		平ネジ / M 4 × 1 2	SCREW	3
19	276522		ストッパー	STOPPER	1
20	7207		六角ナット	NUT	1
21	276527		クランク軸	CRANKSHAFT	1
22	202176		給油紐	OIL WICK	1
23	240368		ピン	PIN	1
24	179320-05		フェルト	OIL FELT	1
25	240148		栓	PLUG	1
26	207358		フェルト	OIL FELT	5
27	276540		油切り案内	GUIDE/FEED BAR OIL SEAL	1
28	276539		油切り	OIL SEAL	1
29	7007		平ネジ / M 3 × 3	SCREW	1
30	276528-91		上送り台 (組)	TOP FEED BAR ASSEMBLY	1
*31	276529		上送り台	TOP FEED BAR	1
*32	276530		上下案内	GUIDE	1
33	7044		皿ネジ / M 4 × 1 0	SCREW	1
34	240294		座金	WASHER	1
35	179160-05		ブッシュ	BUSHING	1
36	7056		六角ネジ / M 5 × 1 3	SCREW	1
37	240039		座金	WASHER	1
38	276531		上送り台案内	GUIDE/TOP FEED BAR	1
39	4543		止ネジ / M 4 × 4	SCREW	1
40	276532		上送り台案内	GUIDE/TOP FEED BAR	1
41	4543		止ネジ / M 4 × 4	SCREW	1
42	XXXXXX		上送り歯	TOP FEED DOG	1
43	7014		平ネジ / M 3 . 5 × 1 0	SCREW	1
44	274035		押エ棒	PRESSER BAR	1
45	240291		圧縮バネ	SPRING	1
46	274036		調節ネジ	SCREW	1
47	274037		ナット	NUT	1
48	273001A92		クランク	CRANK	1
49	273002A92		クランク	CRANK	1
50	4533		平ネジ / M 6 × 1 2	SCREW	1

XXXXXXはゲージパーツです。

52-57頁のゲージパーツ表で確認してください。

XXXXXX is one of the gauge parts.

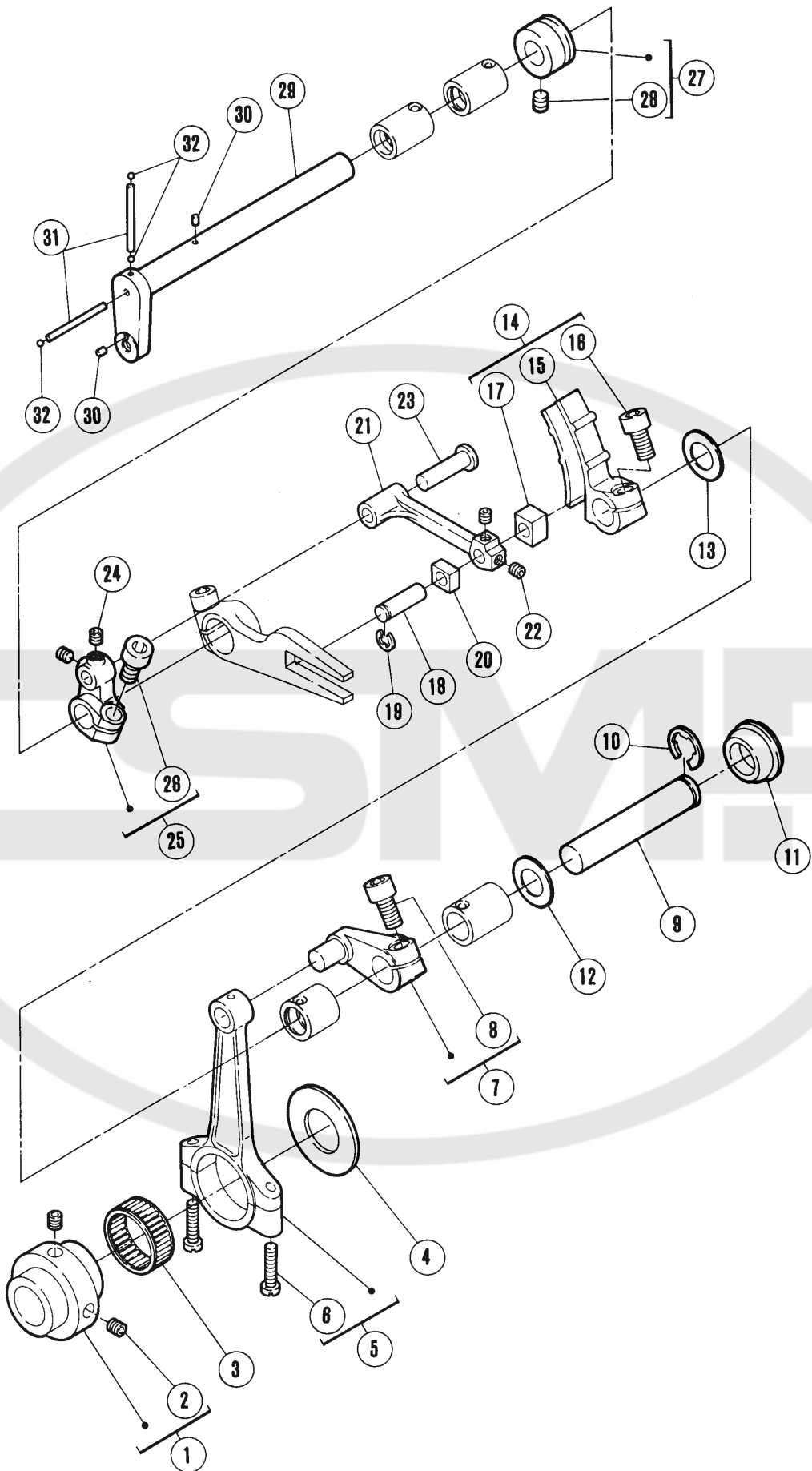

上送り機構(2)

TOP FEED MECHANISM (2)

*=原則販売不可 (Not for sale basically)

REF. NO.	PART NO. 部品番号	名称	NAME	QT.
1	276500-92	エキセン	ECCENTRIC	1
2	4514	止ネジ / M 5 × 5	SCREW	2
3	240298	ニードルベアリング	NEEDLE BEARING	1
4	240297	座金	WASHER	1
5	276501-92	ロッド	CONNECTION	1
6	7024	平ネジ / M 4 × 1 8	SCREW	2
7	276502-92	クランク	CRANK	1
8	4533	平ネジ / M 6 × 1 2	SCREW	1
9	271003B	軸	ROD	1
10	202577	止メ輪	RING	1
11	240110	栓	PLUG	1
12	208235	座金	WASHER	1
13	208235	座金	WASHER	1
14	276504-91	クランク (組)	CRANK ASSEMBLY	1
*15	276505	クランク本体	CRANK	1
16	4533	平ネジ / M 6 × 1 2	SCREW	1
*17	276506	角駒	BLOCK	1
18	276507	平行ピン	PIN	1
19	201629	止メ輪	RING	1
20	276508	角駒	BLOCK	1
21	276509	リンク	LINK	2
22	4543	止ネジ / M 4 × 4	SCREW	1
23	276510	ピン	PIN	1
24	4543	止ネジ / M 4 × 4	SCREW	2
25	276511-92	クランク	CRANK	1
26	4533	平ネジ / M 6 × 1 2	SCREW	1
27	276537-92	カラ	COLLAR	1
28	4514	止ネジ / M 5 × 5	SCREW	1
29	276512	クランク軸	CRANKSHAFT	1
30	207358	フェルト	OIL FELT	2
31	240351	フェルト	FELT	2
32	240148	栓	PLUG	3

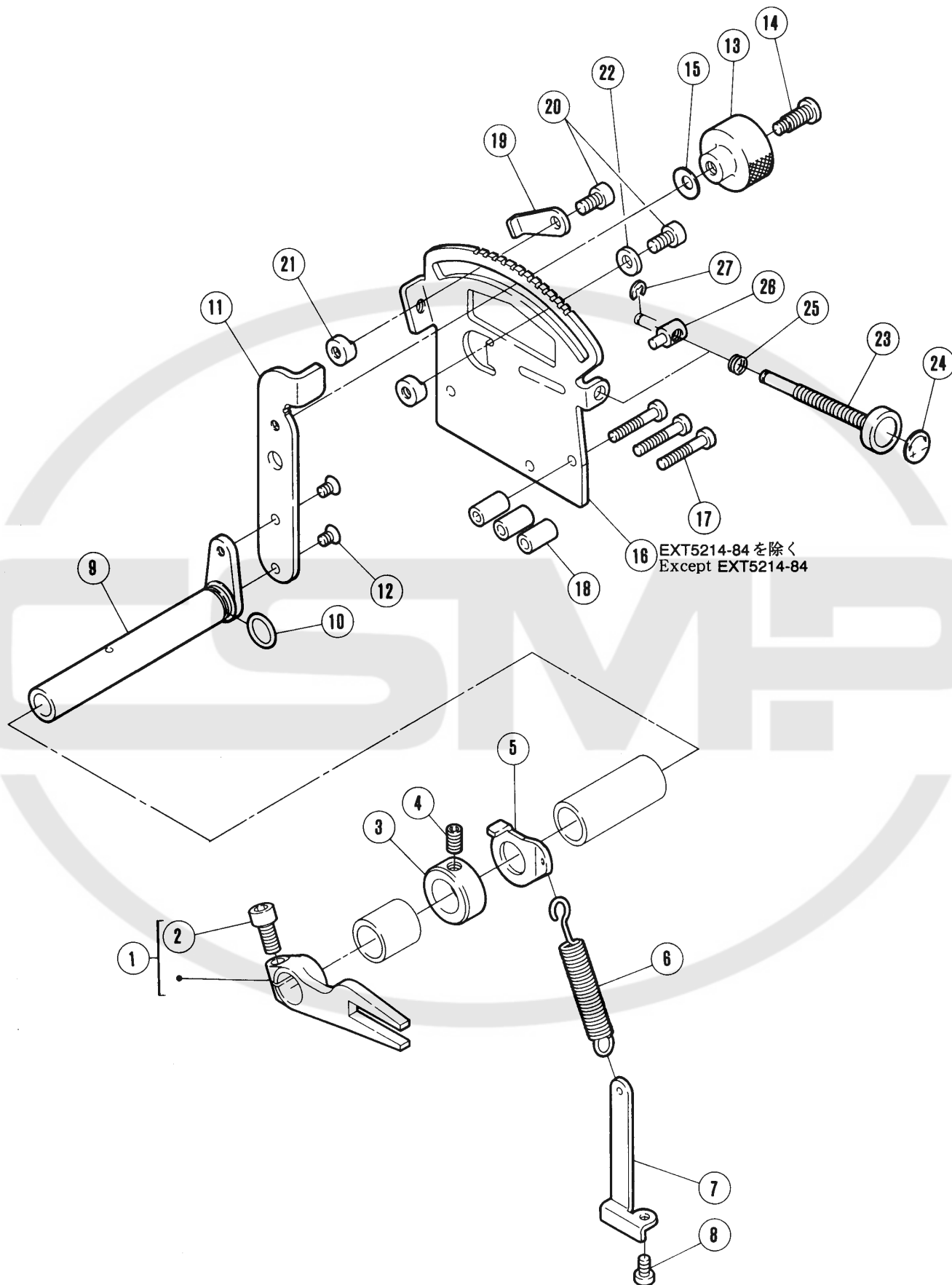

REF. NO.	PART NO. 部品番号	名称	NAME	QT.
1	276513-92	レバー	LEVER	1
2	4534	平ネジ / M 6 × 1 4	SCREW	1
3	240296	カラ	COLLAR	1
4	4521	止ネジ / M 6 × 1 0	SCREW	1
5	276515	ラッチ	LATCH	1
6	276503	引張りバネ	SPRING	1
7	276516	ラッチ	LATCH	1
8	7019	平ネジ / M 4 × 8	SCREW	1
9	276514	軸	ROD	1
10	201022	リング	O RING	1
11	276517	レバー	LEVER	1
12	7077	皿ネジ / M 4 × 7	SCREW	2
13	276519	ナット	NUT	1
14	7059	段付ネジ / 4 . 5	SCREW	1
15	211301	皿バネ	SPRING WASHER	1
16	276518	調節板	BLADE GUIDE	1
17	7026	平ネジ / M 4 × 2 5	SCREW	3
18	240332	スペーサー	SPACER	3
19	276524	ストップバー	STOPPER	1
20	4500	平ネジ / M 5 × 1 0	SCREW	2
21	179201-15	ナット	NUT	2
22	240042	座金	WASHER	1
23	272538A	調節棒	ADJUSTING BAR	1
24	240322	シール	SEAL	1
25	210533	圧縮バネ	SPRING	1
26	272539A	段付ピン	PIN	1
27	200555	止メ輪	RING	1

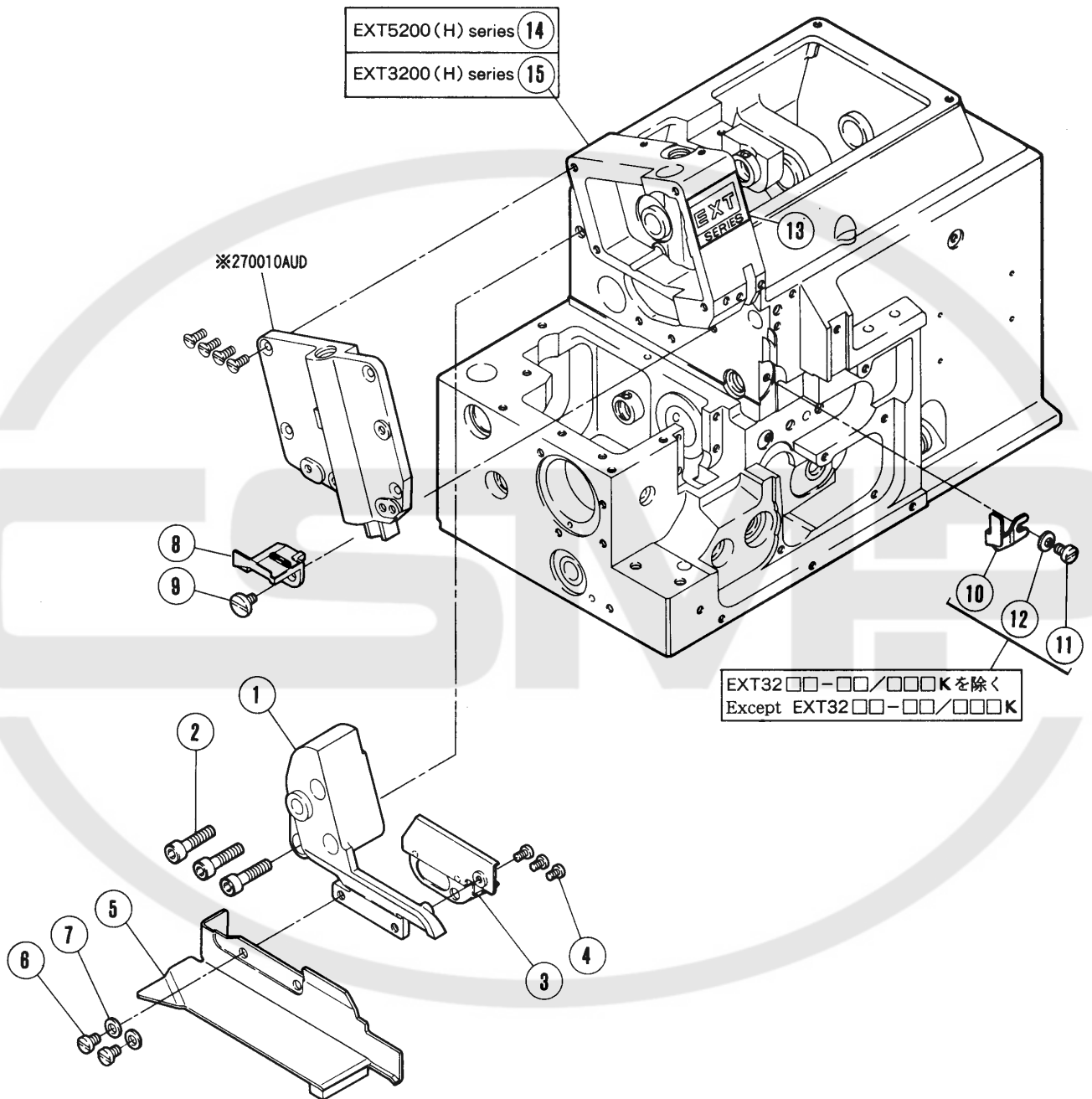

※印は、EX3200H・EX5200Hと共通使用部品です。
Marked ※ parts are the common ones between
EX3200H・EX5200H and EXT series.

カバ-機構

COVER

REF. NO.	PART NO. 部品番号	名称	NAME	QT.
1	270068	ブラケット	BRACKET	1
2	4511	平ネジ / M 6 × 2.5	SCREW	3
3	270067	カバ-	COVER	1
4	7154	平ネジ / M 3 × 3.5	SCREW	3
5	270069-91	布案内	FABRIC GUARD	1
6	7063	平ネジ / M 4.5 × 8	SCREW	2
7	200098	座金	WASHER	2
8	270079	カバ-	COVER	1
9	7066	段付ネジ / M 4	SCREW	1
10	270081	カバ-	COVER	1
11	7143	平ネジ / M 4 × 5.5	SCREW	1
12	210930	皿バネ	SPRING WASHER	1
13	270071	銘板	NAME PLATE	1
14	270073-9S	ベッド (組)	MACHINE BED COMPLETE	1
15	270073A9S	ベッド (組)	MACHINE BED COMPLETE	1

EXT5200 (H) series

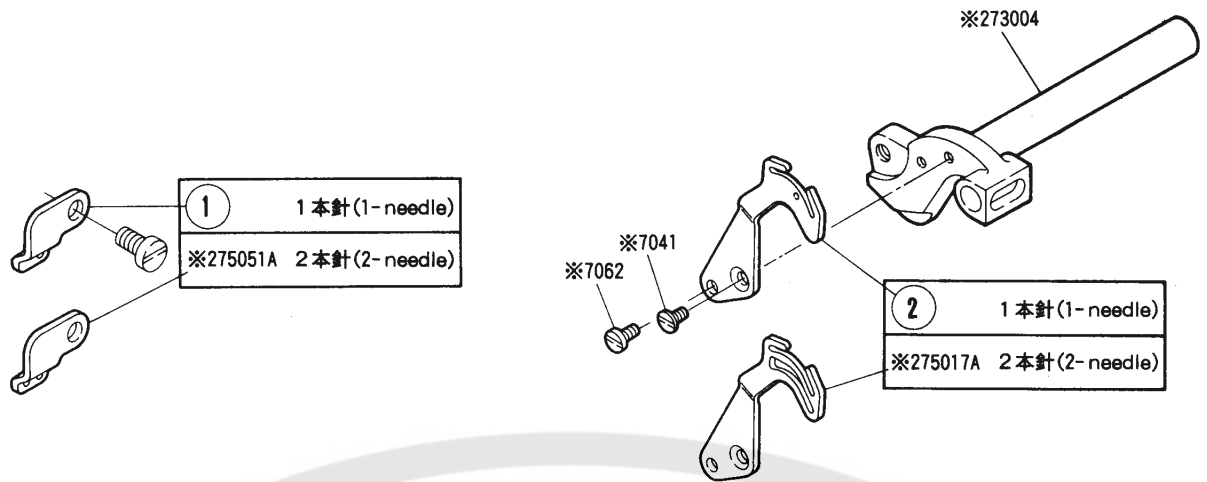

EXT3200 (H) series

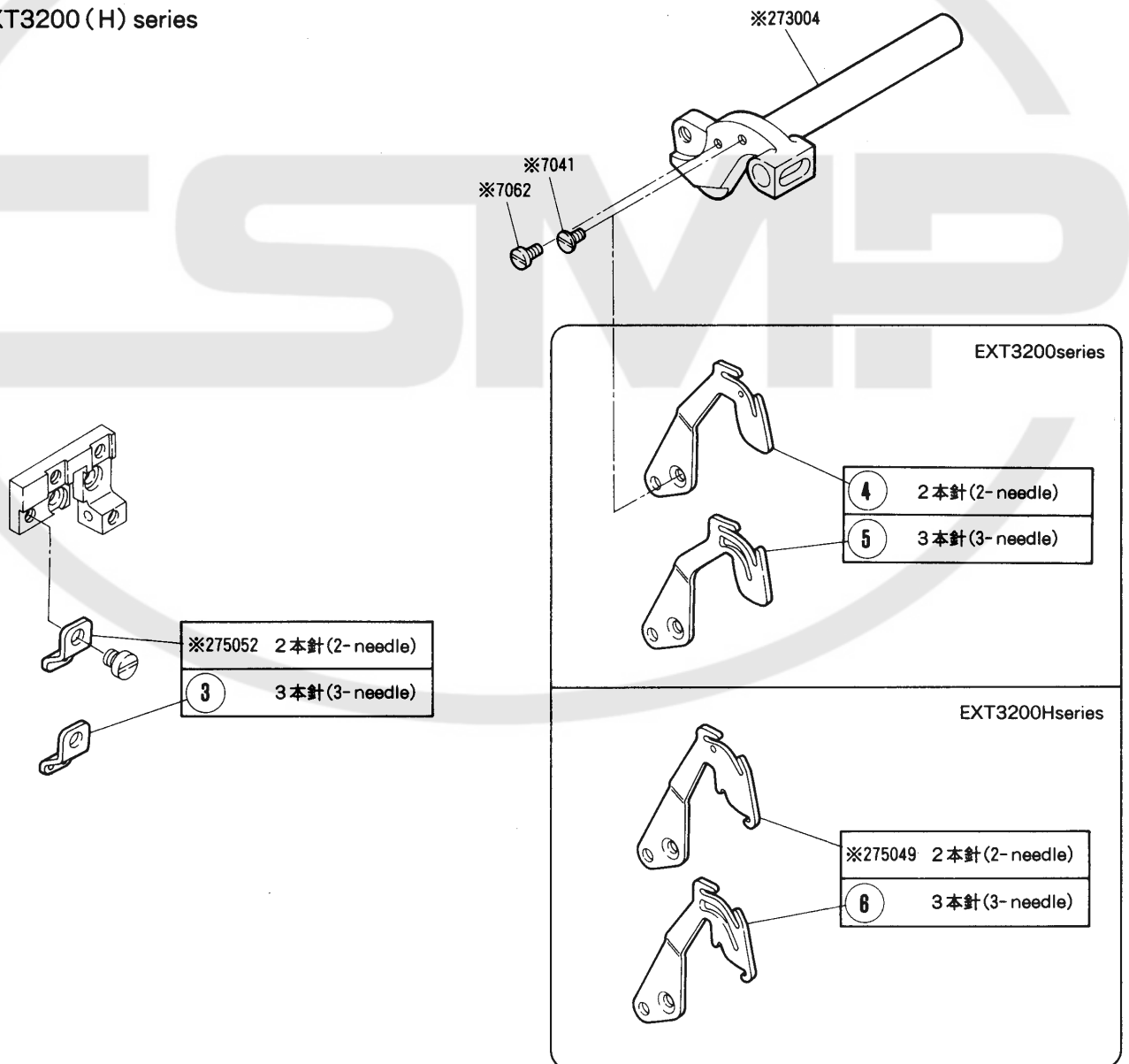

※印は、EX3200H・EX5200Hと共通使用部品です。
Marked ※ parts are the common ones between
EX3200H・EX5200H and EXT series.

[糸道・糸繰り関係]

REF. NO.	PART NO. 部品番号	名称	NAME	QT.
1	275051	糸道	THREAD EYELET	1
2	275016A	針糸繰り	THREAD TAKEUP	1
3	275052A	糸道	THREAD EYELET	1
4	275027A	針糸繰り	THREAD TAKEUP	1
5	275044A	針糸繰り	THREAD TAKEUP	1
6	275050	針糸繰り	THREAD TAKEUP	1



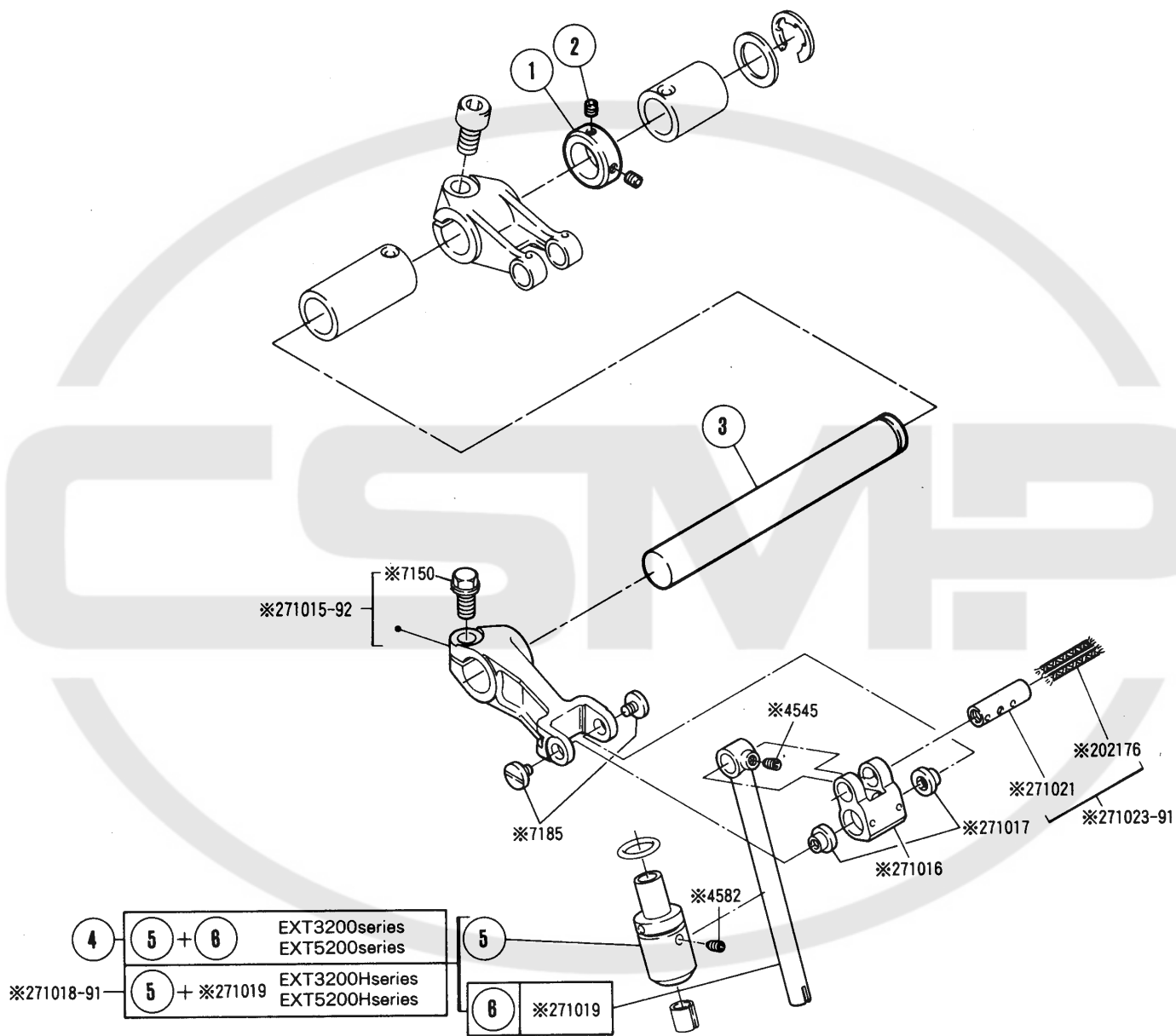

※印は、EX3200H・EX5200Hと共通使用部品です。
 Marked ※ parts are the common ones between
 EX3200H・EX5200H and EXT series.

針振り機構

NEEDLE DRIVE MECHANISM

*=原則販売不可 (Not for sale basically)

REF. PART NO.	NO. 部品番号	名称	NAME	QT.
	1 240292	カラー	COLLAR	1
	2 4554	止ネジ / M 3 × 3	SCREW	2
	3 271003A	軸	ROD	1
	4 271018A91	ブッシュ (組) / 針棒	BUSHING ASSEMBLY	1
*	5 271020	ブッシュ	BUSHING	1
*	6 271019A	針棒	NEEDLE BAR	1



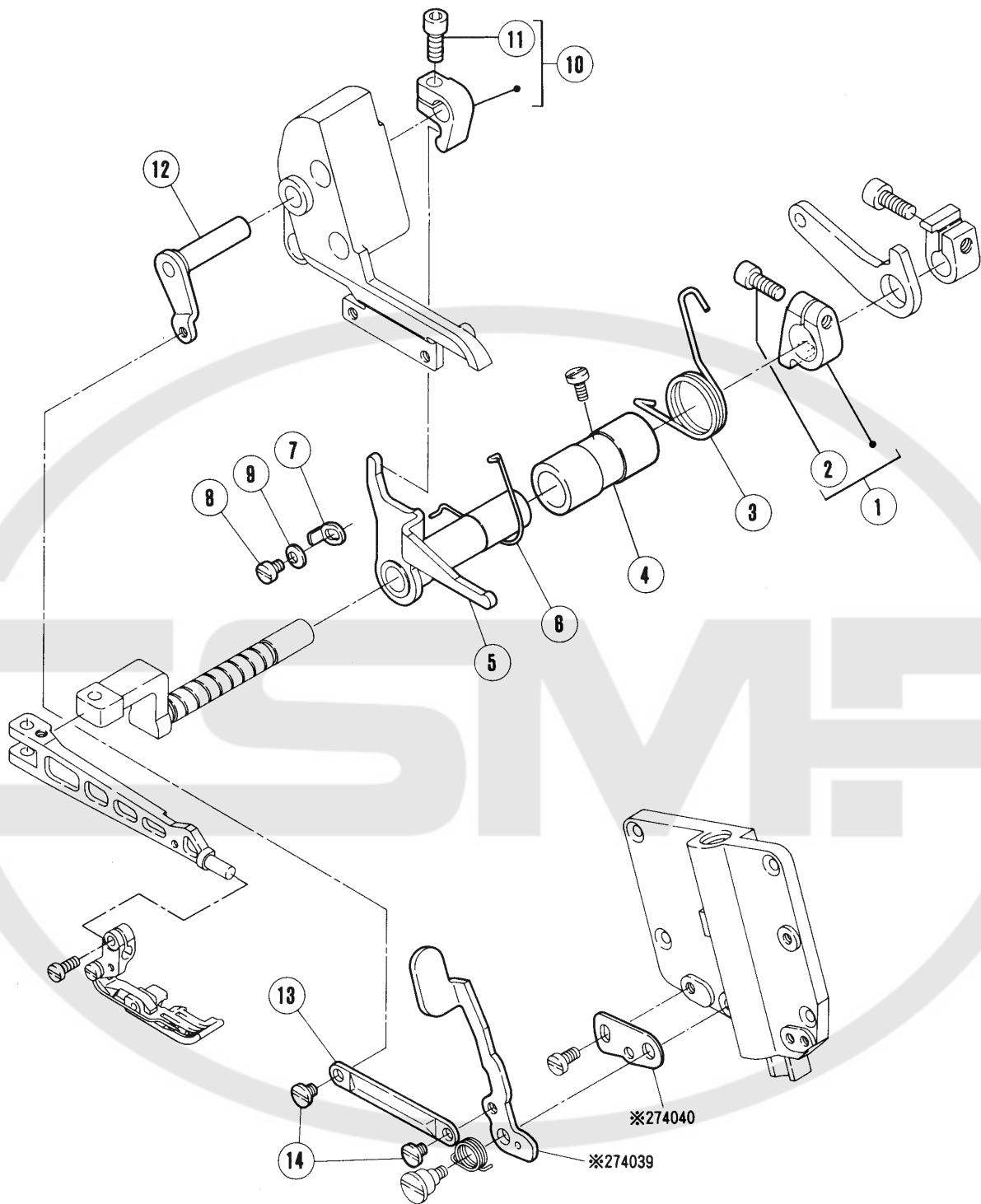

※印は、EX3200H・EX5200Hと共通使用部品です。
 Marked ※ parts are the common ones between
 EX3200H・EX5200H and EXT series.

REF. NO.	PART NO.	名称	NAME	QT.
1	274042-92	カラー	COLLAR	1
2	4501	平ネジ / M 5 × 1 4	SCREW	1
3	274043	ネジリバネ	SPRING	1
4	274044	ブッシュ	BUSHING	1
5	274045-91	レバー	LEVER	1
6	274055	線細工バネ	SPRING	1
7	274054	ストッパー	STOPPER	1
8	7018	平ネジ / M 4 × 6	SCREW	1
9	210930	皿バネ	SPRING WASHER	1
10	213218A92	レバー	LEVER	1
11	4531	平ネジ / M 5 × 1 2	SCREW	1
12	274048-91	レバー	LEVER	1
13	274041	リンク	LINK	1
14	7193	段付ネジ	SCREW	2

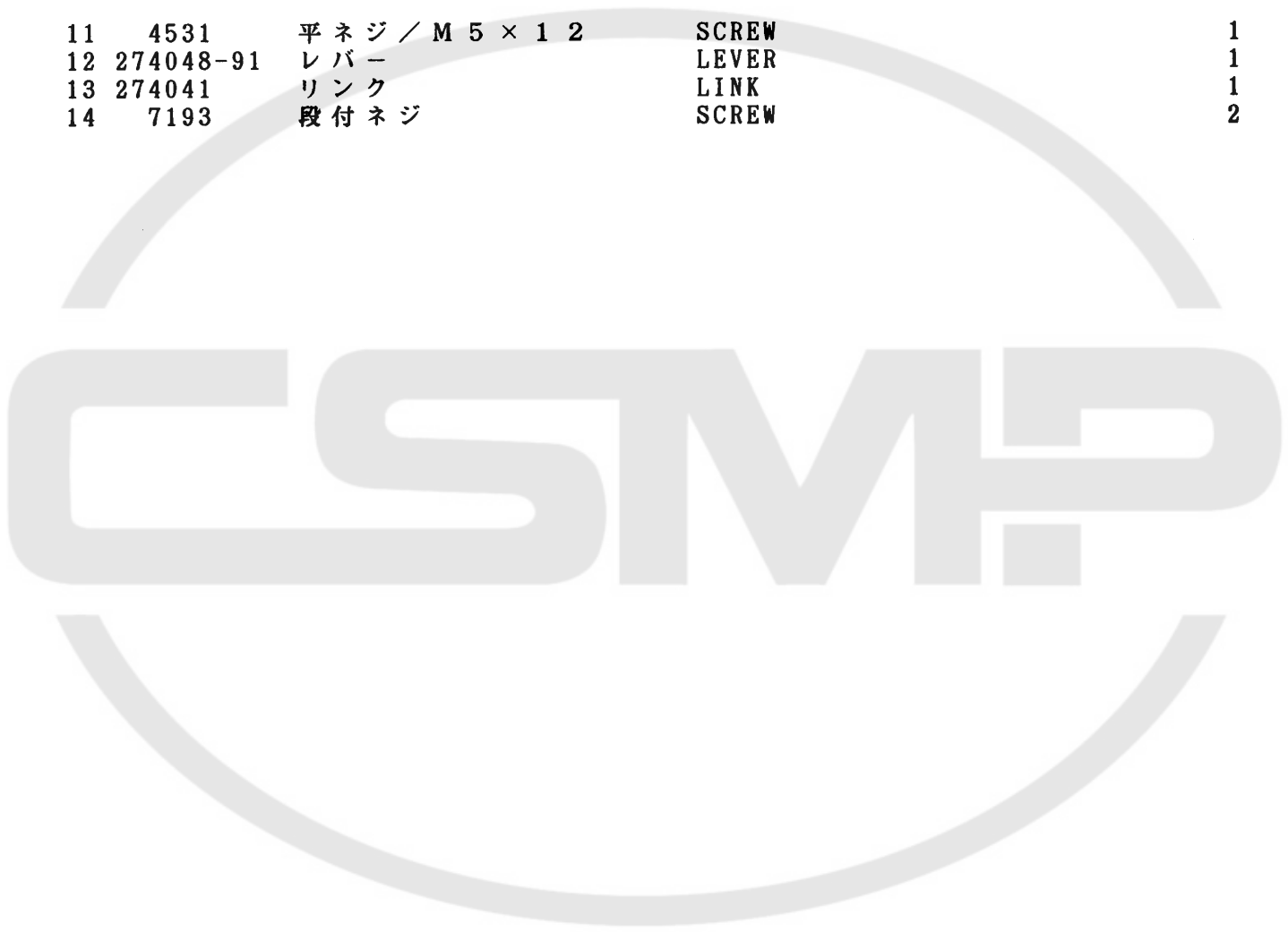

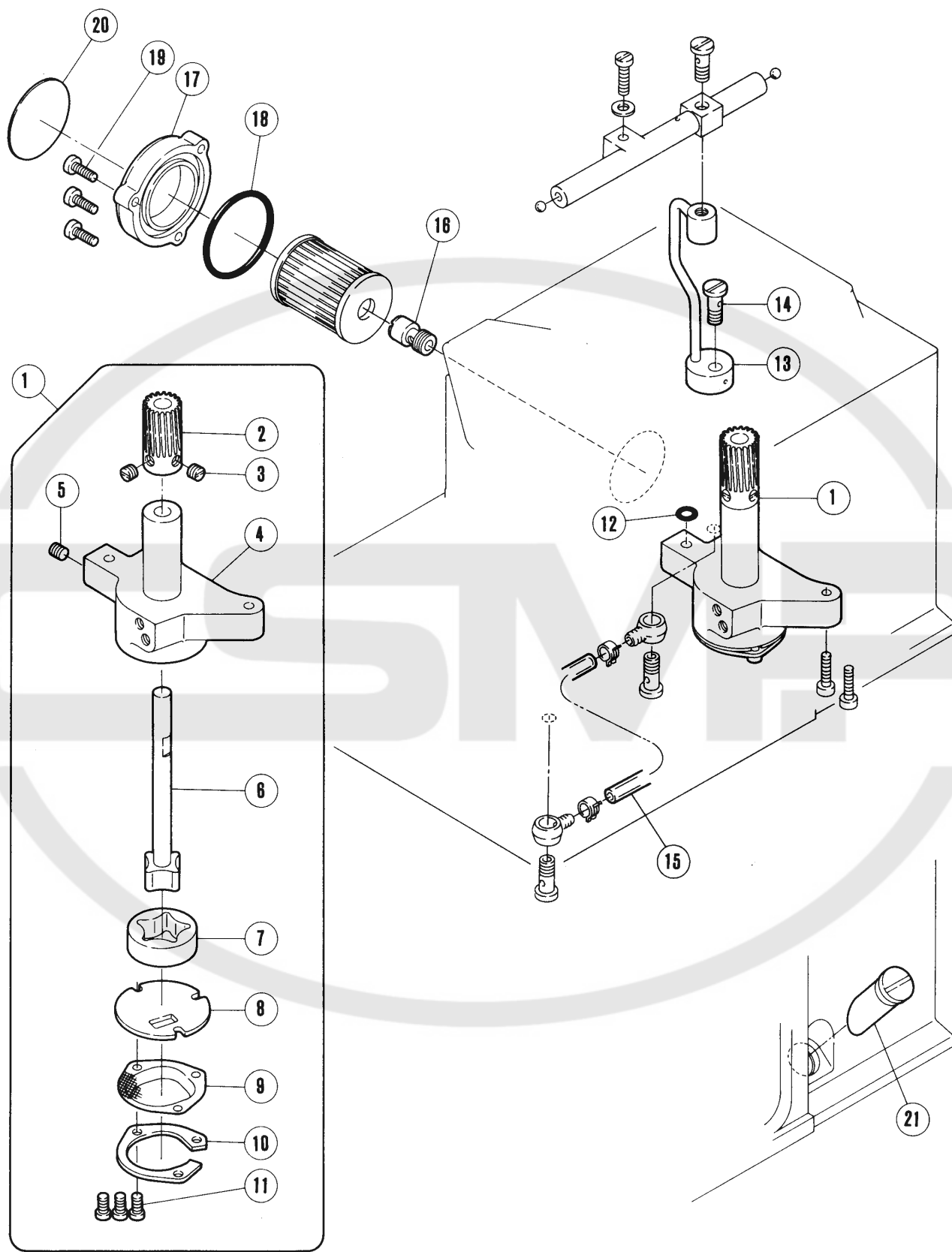

給油機構(1)

LUBRICATION MECHANISM (1)

* =原則販売不可 (Not for sale basically)

REF. NO.	PART NO.	部品番号	名称	NAME	QT.
	1	274546-91	ポンプ (組)	OIL PUMP ASSEMBLY	1
	2	211618	ウォームホイール	WORM WHEEL	1
	3	5060	止ネジ / C 8 × 4 . 5	SCREW	2
*	4	274547	ポンプ本体	PUMP BODY	1
	5	4522	止ネジ / M 6 × 6	SCREW	1
*	6	212978-91	ローター (内) 軸	ROTOR (INSIDE) SHAFT	1
*	7	212981	ローター (外)	ROTOR (OUTSIDE)	1
	8	274508	側板	CASING PLATE	1
	9	213578	フィルター	FILTER	1
	10	213579	当金	GUIDE	1
	11	7013	平ネジ / M 3 . 5 × 8	SCREW	3
	12	204185	Oリング	O RING	1
	13	274532-91	油配分器	OIL DISTRIBUTOR	1
	14	240328	継手ネジ	SCREW	1
	15	205113A	給油パイプ	OIL TUBE	1
	16	274528	継手	JOINT	1
	17	210201-SD	フィルター 蓋	OIL FILTER CAP	1
	18	206431	Oリング	O RING	1
	19	7021	平ネジ / M 4 × 1 2	SCREW	3
	20	9A3002	フィルター シール	FILTER SEAL	1
	21	274539	オイルゲージ	OIL SIGHT GAUGE	1

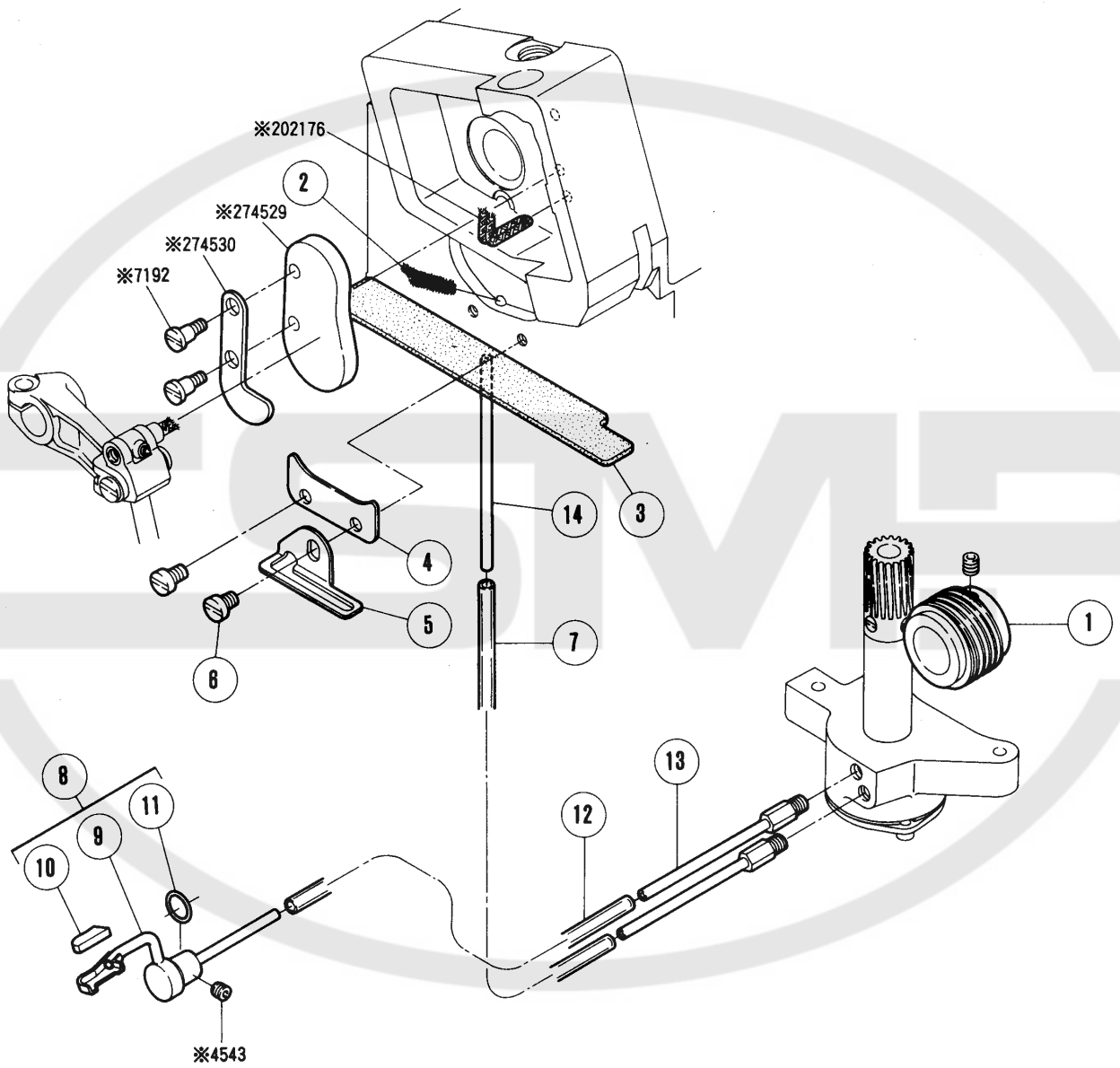

※印は、EX3200H・EX5200Hと共通使用部品です。
 Marked ※ parts are the common ones between
 EX3200H・EX5200H and EXT series.

REF. NO.	PART NO. 部品番号	名称	NAME	QT.
1	274507	ウォーム	WORM	1
2	240152	モール	OIL WICK	1
3	274549	フェルト	FELT	1
4	274550	カバー	COVER	1
5	274559	当金	SPACER	1
6	7018	平ネジ / M 4 × 6	SCREW	1
7	212152	チューブ	TUBE	1
8	274551A91	継手 (組)	JOINT	1
9	274552A91	継手	JOINT	1
10	274556	フェルト	OIL FELT	1
11	204185	Oリング	O RING	1
12	240371	チューブ	TUBE	1
13	274548-91	継手	JOINT	2
14	210320	排油管	EXHAUST OIL DISTRIBUTOR	1



CSMP

地縫い (Plain seaming)
EXT5200(H) Series

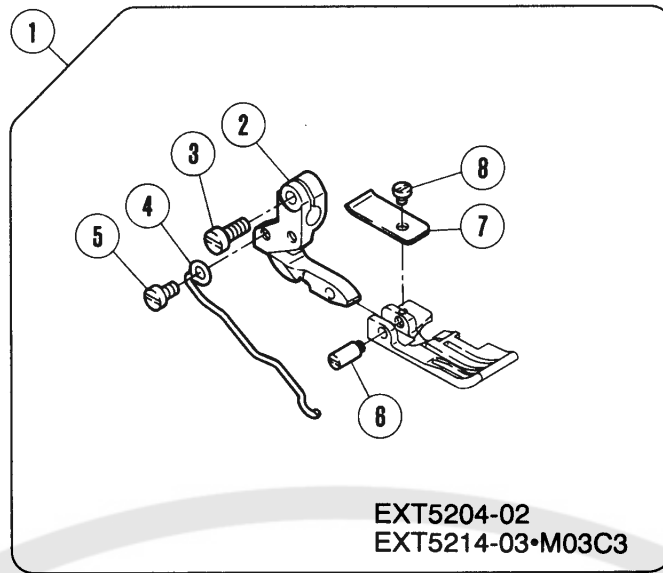

EXT3200(H) Series

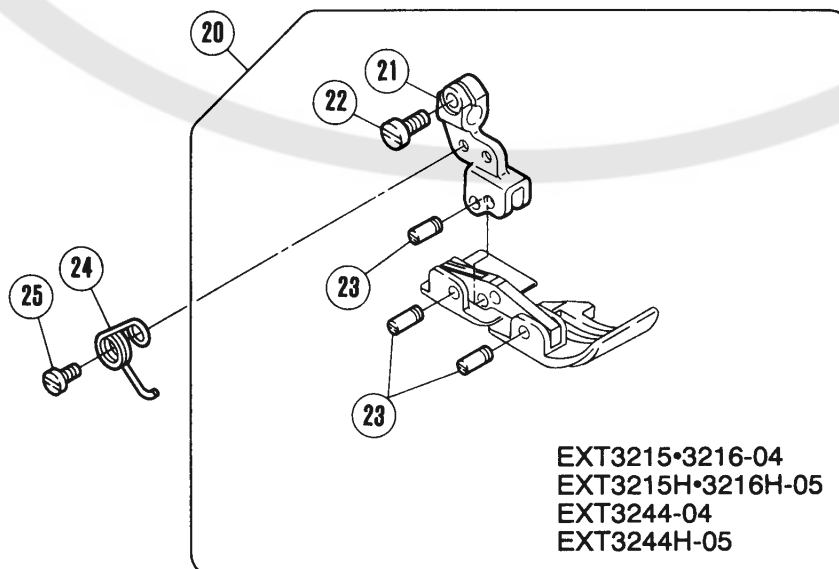
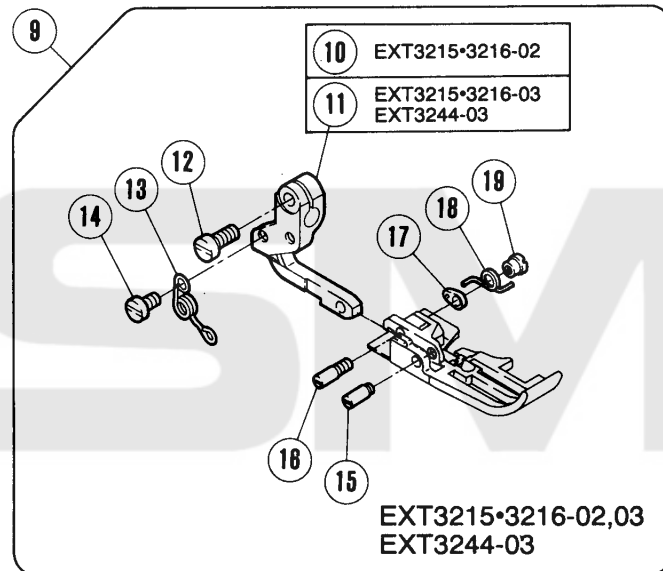

専用部品(1)

SPECIFIC PARTS (1)

*=原則 販売不可 (Not for sale basically)

REF. NO.	PART NO.	部品番号	名称	NAME	QT.
	1	XXXXXX	押エ (組)	PRESSER FOOT COMPLETE	1
*	2	277136	ホルダー	HOLDER	1
	3	7013	平ネジ / M 3 . 5 × 8	SCREW	1
	4	274051	ネジリバネ	SPRING	1
	5	7009	平ネジ / M 3 × 5	SCREW	1
	6	212059-B	ピン	PIN	1
	7	212668	補助板	EUXILIARY PLATE	1
	8	5030	平ネジ / C 1 × 2 . 3	SCREW	1
	9	XXXXXX	押エ (組)	PRESSER FOOT COMPLETE	1
*	10	277138	ホルダー	HOLDER	1
*	11	277139	ホルダー	HOLDER	1
	12	7013	平ネジ / M 3 . 5 × 8	SCREW	1
	13	274053	ネジリバネ	SPRING	1
	14	7009	平ネジ / M 3 × 5	SCREW	1
	15	209229-B	ピン	PIN	1
	16	209229AB	ピン	PIN	1
	17	212498	ラッチ	LATCH	1
	18	274028	ネジリバネ	SPRING	1
	19	3153	ナット	NUT	1
	20	XXXXXX	押エ (組)	PRESSER FOOT COMPLETE	1
*	21	277130	ホルダー	HOLDER	1
	22	7013	平ネジ / M 3 . 5 × 8	SCREW	1
	23	208958-B	ピン付ネジ / C 3	SCREW	3
	24	274034	ネジリバネ	SPRING	1
	25	7008	平ネジ / M 3 × 4	SCREW	1

裾引き (Blindhemming)
EXT5205-12

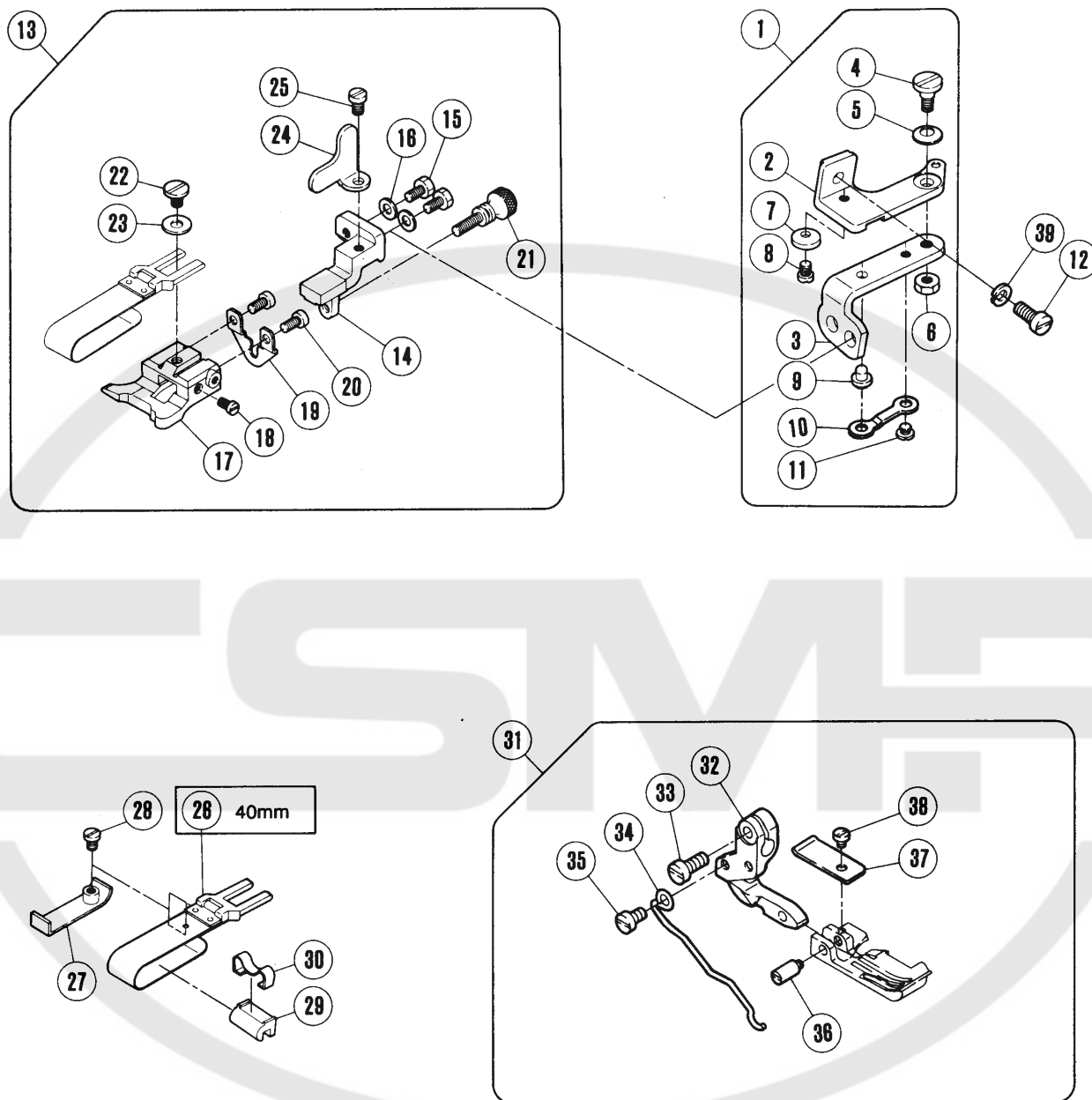

専用部品(2)

SPECIFIC PARTS (2)

*=原則 販売不可 (Not for sale basically)

REF. NO.	PART NO.	名 称	NAME	QT.
1	210685	定規ブラケット (組)	CLOTH GUIDE BRACKET ASSEMBLY	1
2	210680	定規ブラケット	CLOTH GUIDE BRACKET	1
3	210681	ヒンジ/定規ブラケット	HINGE/EDGE GUIDE BRACKET	1
4	5184	段付ネジ / C 5	SCREW	1
5	201191	皿バネ	SPRING	1
6	3044	六角ナット / C 5	NUT	1
7	210682	ストッパー / ヒンジ	STOPPER	1
8	5053	平ネジ / C 4 × 4 . 8	SCREW	1
9	210683	段付ピン	PIN	1
10	210684	板バネ	FLAT SPRING	1
11	2906	平ネジ / C 4 × 2 . 6	SCREW	1
12	7020	平ネジ / M 4 × 1 0	SCREW	1
13	210691	裾引定規台 (組)	CLOTH GUIDE COMPLETE	1
14	210690	ブラケット	BRACKET	1
15	5088	六角ネジ / C 4 × 7 . 5	SCREW	2
16	167066	座金	WASHER	2
17	205361	裾引定規台	CLOTH GUIDE	1
18	5057	平ネジ / C 3 × 5	SCREW	1
19	210689	調節板	ADJUSTING PLATE	1
20	5157	平ネジ / C 3 × 4 . 5	SCREW	2
21	2430	調節ネジ / C 3	SCREW	1
22	2905	平ネジ / C 5 × 4 . 5	SCREW	1
23	137142	座金	WASHER	1
24	210692	ストッパー	STOPPER	1
25	1206	平ネジ / C 4 × 5 . 3	SCREW	1
26	201211C91	定規羽根 (40MM)	FOLDER COMPLETE (40MM)	1
27	205835	補助羽根	AUXILIARY PLATE	1
28	5299	平ネジ / C 3 × 2 . 6	SCREW	1
29	303312A	羽根駒	REGULATOR	1
30	303313	板バネ	FLAT SPRING	1
31	XXXXXX	押エ (組)	PRESSER FOOT COMPLETE	1
*32	277136	ホルダー	HOLDER	1
33	7013	平ネジ / M 3 . 5 × 8	SCREW	1
34	274051	ネジリバネ	SPRING	1
35	7009	平ネジ / M 3 × 5	SCREW	1
36	212059-B	ピン	PIN	1
37	212668	補助板	EUXILIARY PLATE	1
38	5030	平ネジ / C 1 × 2 . 3	SCREW	1
39	201252	バネ座金	SPRING WASHER	1

ヒタ取り (Shirring)

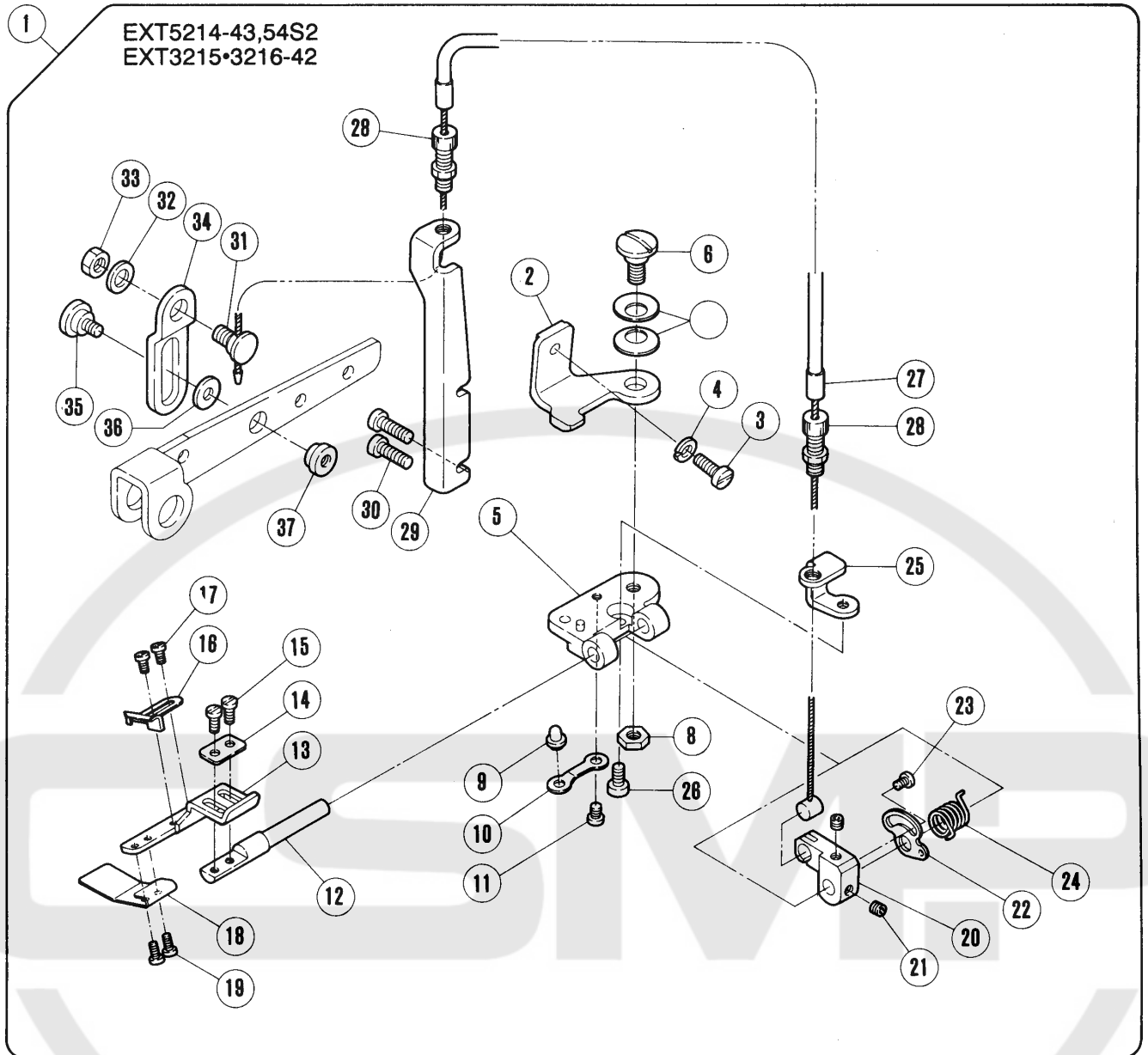

テープ付け (Attaching tape)

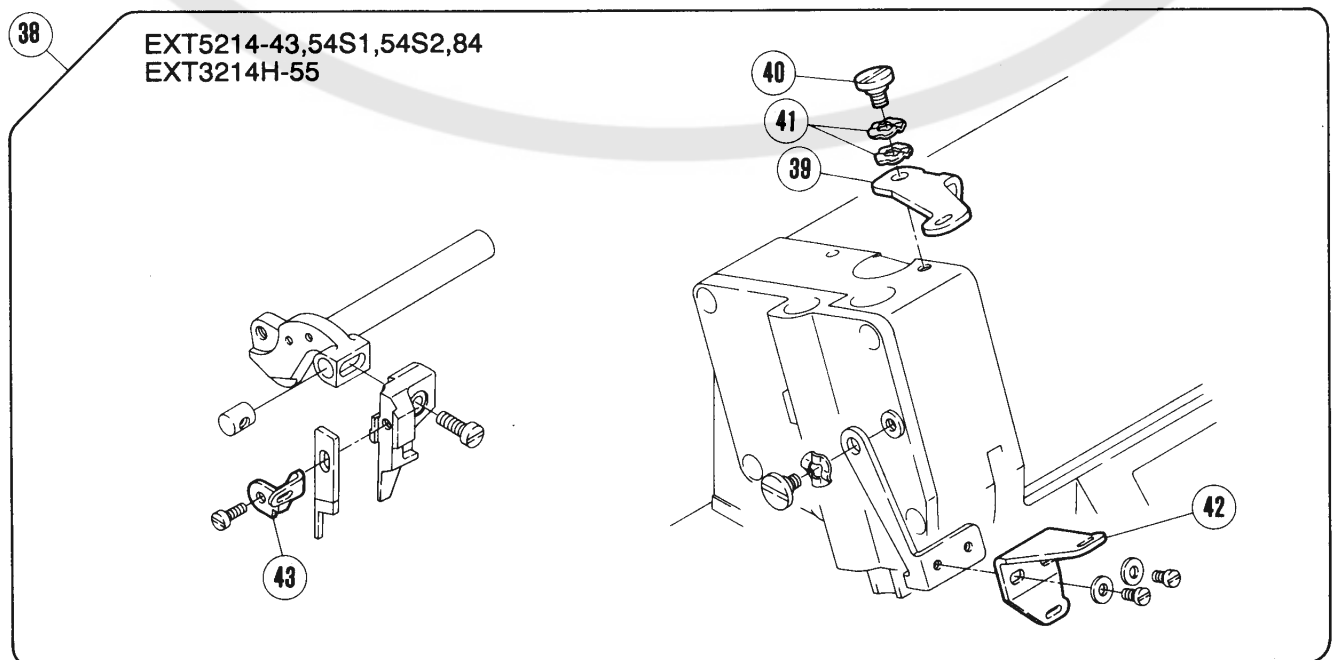

専用部品(3)

SPECIFIC PARTS (3)

REF. NO.	PART NO.	部品番号	名称	NAME	QT.
1	275532-91		ヒダ取り装置 (組)	SHIRRING ATTACHMENT COMPLETE	1
2	275533		ブラケット	BRACKET	1
3	7020		平ネジ / M 4 × 1 0	SCREW	1
4	201252		バネ座金	SPRING WASHER	1
5	212601		ブラケット	BRACKET	1
6	5380		段付ネジ / C 8	SCREW	1
7	204888		皿バネ	SPRING	2
8	5104		六角ナット / C 8	NUT	1
9	210683		段付ピン	PIN	1
10	210684		板バネ	FLAT SPRING	1
11	1234		平ネジ / C 4 × 3 . 8	SCREW	1
12	212603		軸	ROD	1
13	275539		ブラケット	BRACKET	1
14	210955		座金	WASHER	1
15	1196		平ネジ / C 3 × 6 . 5	SCREW	2
16	212660		布ガイド	CLOTH GUIDE	1
17	5077		平ネジ / C 1 × 3	SCREW	2
18	212658		ブレード	SHIRRING BLADE	1
19	5077		平ネジ / C 1 × 3	SCREW	2
20	275534		ブラケット	BRACKET	1
21	4543		止ネジ / M 4 × 4	SCREW	2
22	275535		ラッチ	LATCH	1
23	7008		平ネジ / M 3 × 4	SCREW	1
24	275537		ネジリバネ	SPRING	1
25	275536		ブラケット	BRACKET	1
26	7021		平ネジ / M 4 × 1 2	SCREW	1
27	212435		ケーブル	CABLE	1
28	212436		ケーブル受ケ	CABLE SUPPORT	2
29	275523		ブラケット	BRACKET	1
30	7022		平ネジ / M 4 × 1 4	SCREW	2
31	7099		段付ネジ / M 6	SCREW	1
32	202433		座金	WASHER	1
33	4806		六角ナット / M 6	NUT	1
34	275522		ラッチ	LATCH	1
35	7164		段付ネジ / M 4	SCREW	1
36	240104		座金	WASHER	1
37	179765-15		ナット / M 4	NUT	1
38	275542-91		テープ案内 (組)	TAPE GUIDE ASSEMBLY	1
39	275510		テープ案内	TAPE GUIDE	1
40	7066		段付ネジ / M 4	SCREW	1
41	210307		波板座金	WASHER	2
42	275511		テープ案内	TAPE GUIDE	1
43	211267		テープ繰り	TAPE TAKEUP	1

ヒダ取り (Shirring)

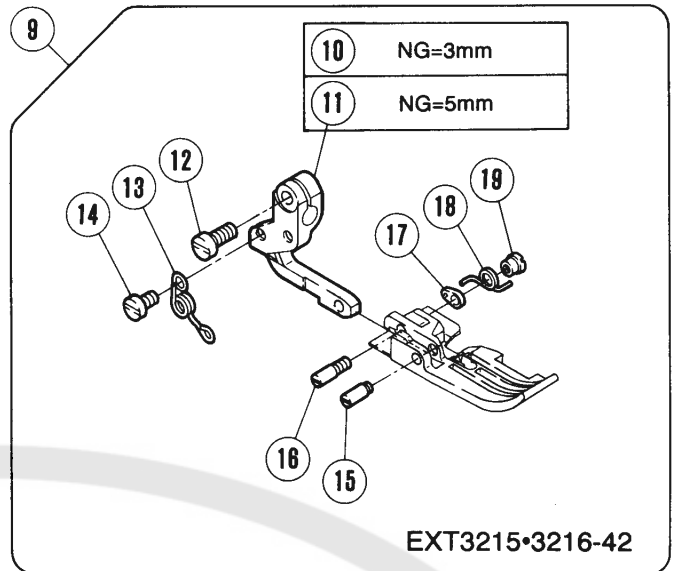
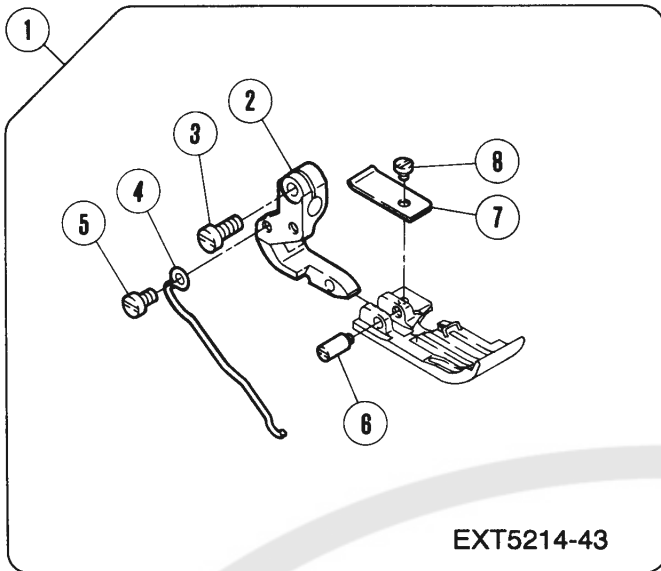

テープ付け (Attaching tape)

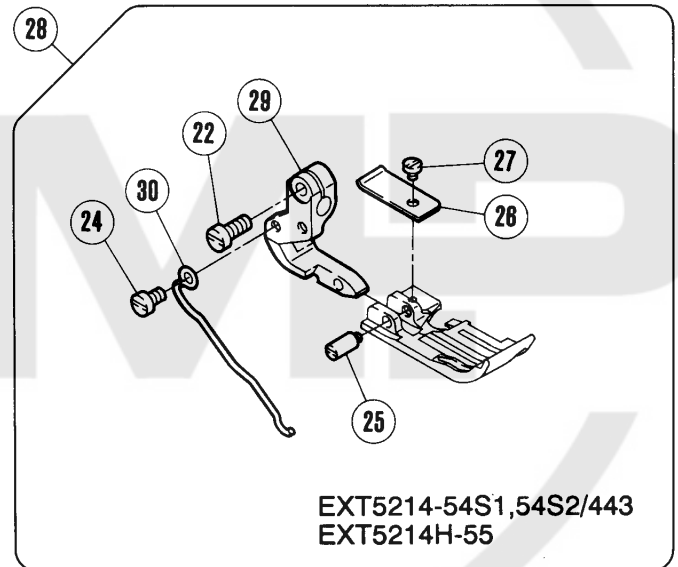
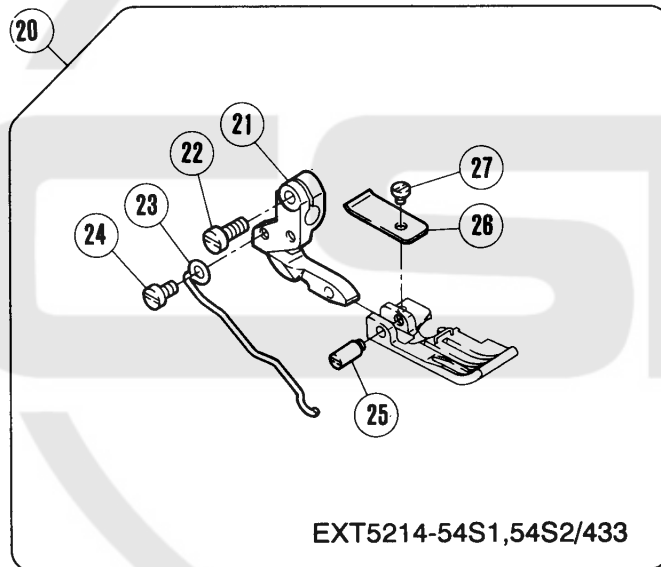

バックタック (Backlatching)

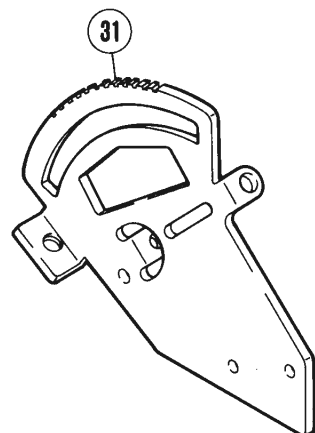
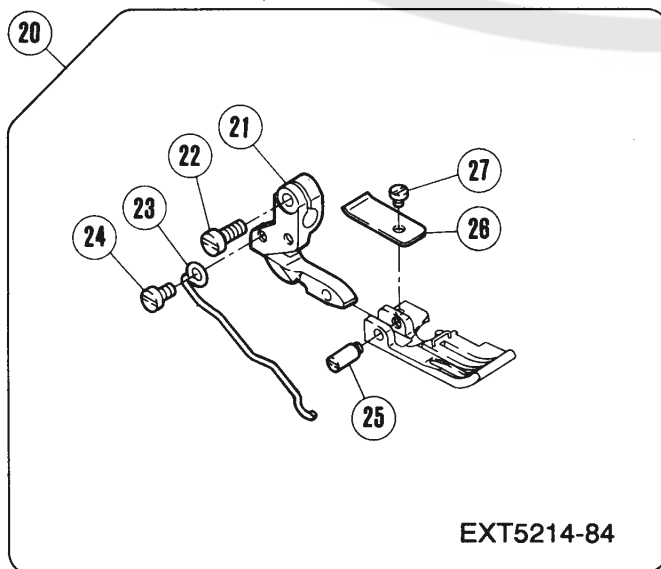

専用部品(4)

SPECIFIC PARTS (4)

*=原則販売不可 (Not for sale basically)

REF. NO.	PART NO.	名称	NAME	QT.
	1 XXXXXX	押エ (組)	PRESSER FOOT COMPLETE	1
*	2 277137	ホルダー	HOLDER	1
	3 7013	平ネジ / M 3 . 5 × 8	SCREW	1
	4 274052	ネジリバネ	SPRING	1
	5 7009	平ネジ / M 3 × 5	SCREW	1
	6 212059-B	ピン	PIN	1
	7 212668	補助板	EUXILIARY PLATE	1
	8 5030	平ネジ / C 1 × 2 . 3	SCREW	1
	9 XXXXXX	押エ (組)	PRESSER FOOT COMPLETE	1
*	10 277138	ホルダー	HOLDER	1
*	11 277139	ホルダー	HOLDER	1
	12 7013	平ネジ / M 3 . 5 × 8	SCREW	1
	13 274053	ネジリバネ	SPRING	1
	14 7009	平ネジ / M 3 × 5	SCREW	1
	15 209229-B	ピン	PIN	1
	16 209229AB	ピン	PIN	1
	17 212498	ラッチ	LATCH	1
	18 274056	ネジリバネ	SPRING	1
	19 3153	ナット	NUT	1
	20 XXXXXX	押エ (組)	PRESSER FOOT COMPLETE	1
*	21 277137	ホルダー	HOLDER	1
	22 7013	平ネジ / M 3 . 5 × 8	SCREW	1
	23 274051	ネジリバネ	SPRING	1
	24 7009	平ネジ / M 3 × 5	SCREW	1
	25 212059-B	ピン	PIN	1
	26 212668	補助板	EUXILIARY PLATE	1
	27 5030	平ネジ / C 1 × 2 . 3	SCREW	1
	28 XXXXXX	押エ (組)	PRESSER FOOT COMPLETE	1
*	29 277137	ホルダー	HOLDER	1
	30 274052	ネジリバネ	SPRING	1
	31 276525	調節板	BLADE GUIDE	1

パイピング (Piping)

EXT5214-C3P1,C3P2

EXT3215・3216-C3P1,C3P2

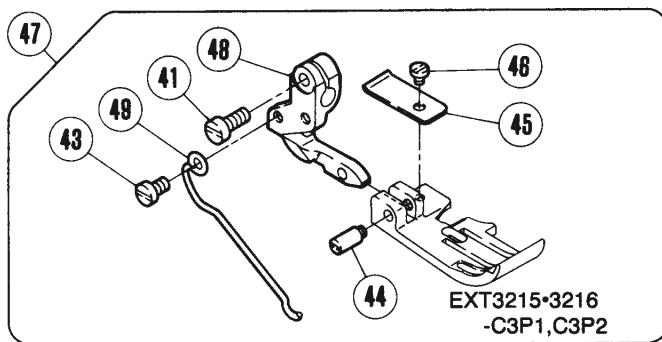
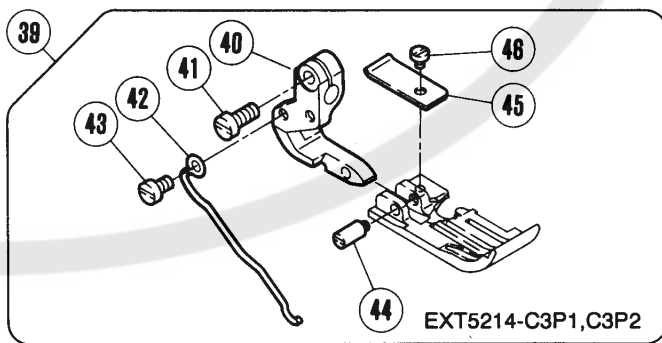
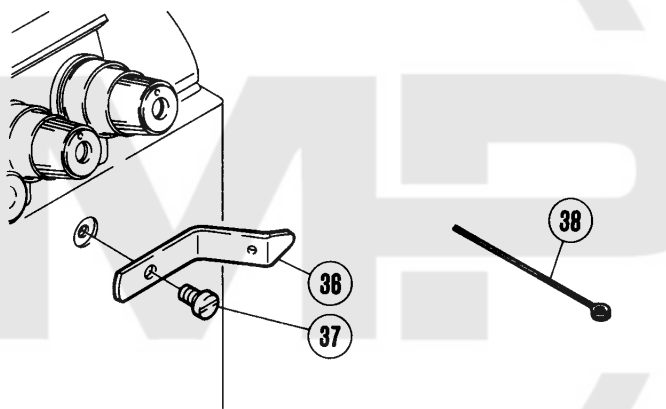
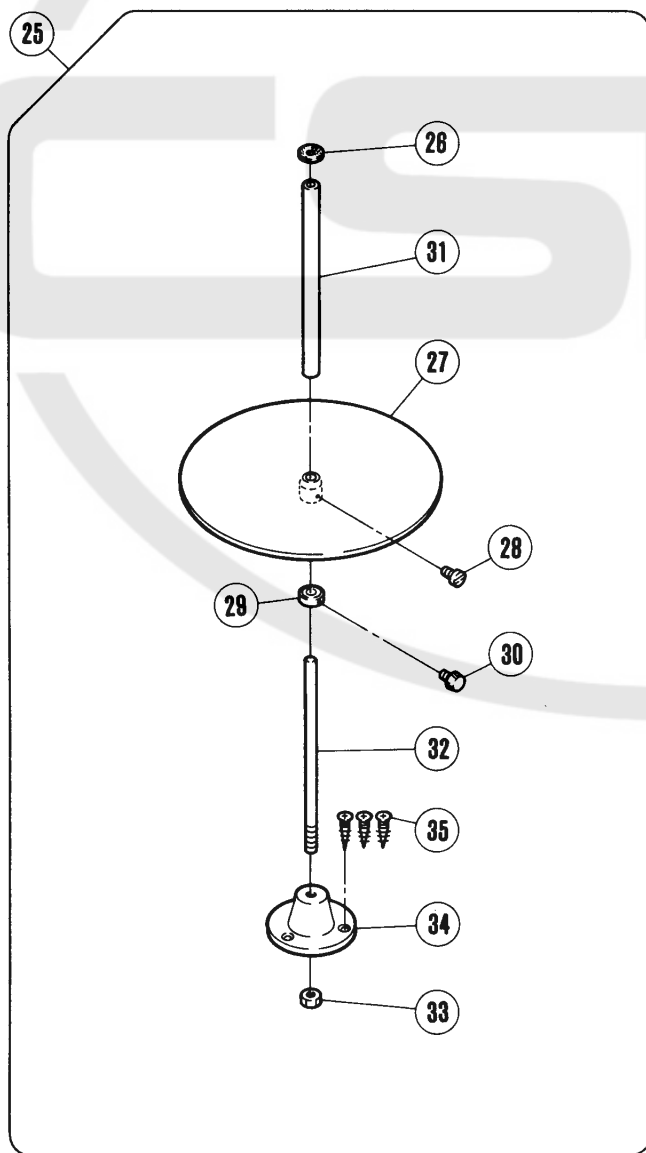
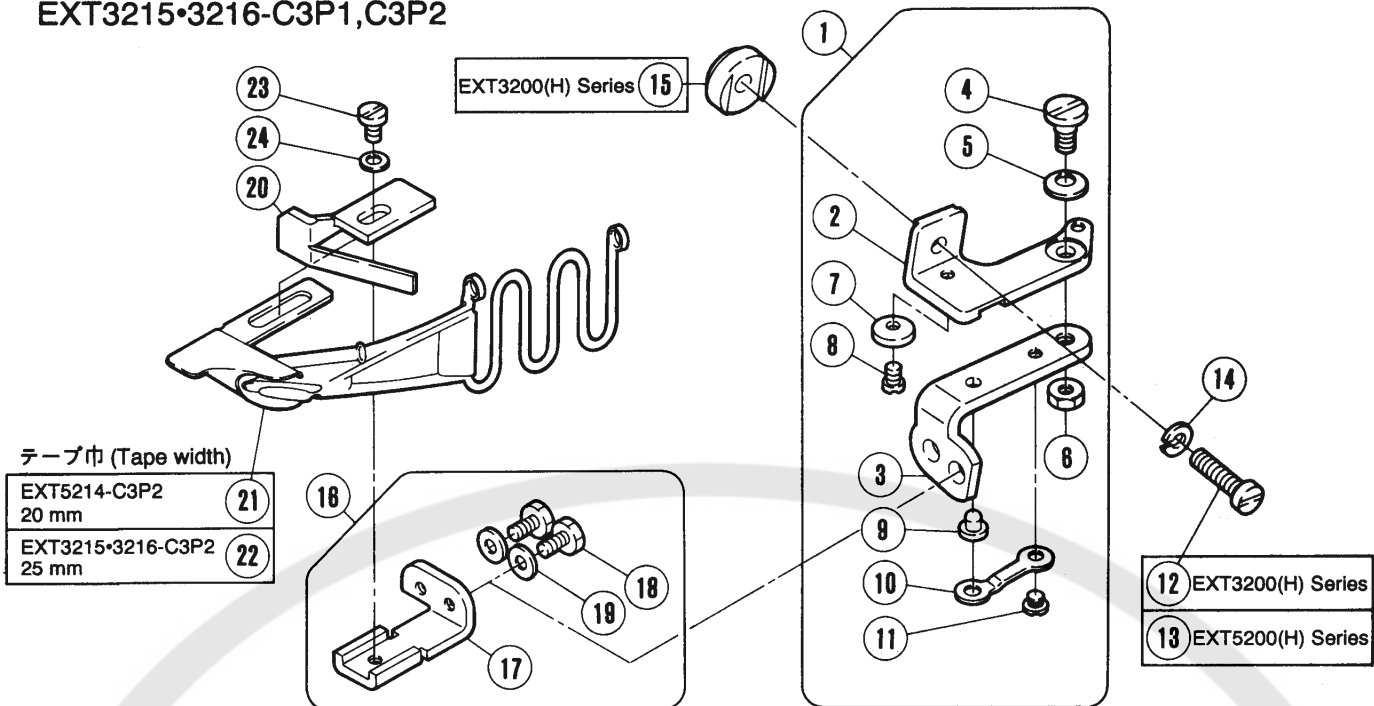

専用部品(5)

SPECIFIC PARTS (5)

*=原則 販売不可 (Not for sale basically)

REF. NO.	PART NO.	名 称	NAME	QT.
1	210685	定規ブラケット (組)	CLOTH GUIDE BRACKET ASSEMBLY	1
2	210680	定規ブラケット	CLOTH GUIDE BRACKET	1
3	210681	ヒンジ/定規ブラケット	HINGE/EDGE GUIDE BRACKET	1
4	5184	段付ネジ / C 5	SCREW	1
5	201191	皿バネ	SPRING	1
6	3044	六角ナット / C 5	NUT	1
7	210682	ストッパー / ヒンジ	STOPPER	1
8	5053	平ネジ / C 4 × 4 . 8	SCREW	1
9	210683	段付ピン	PIN	1
10	210684	板バネ	FLAT SPRING	1
11	2906	平ネジ / C 4 × 2 . 6	SCREW	1
12	7023	平ネジ / M 4 × 1 6	SCREW	1
13	7020	平ネジ / M 4 × 1 0	SCREW	1
14	201252	バネ座金	SPRING WASHER	1
15	212287	スペーサー	SPACER	1
16	210686	当定規台 (組)	BRACKET COMPLETE/EDGE GUIDE	1
17	210687	当定規台	BRACKET/EDGE GUIDE	1
18	5088	六角ネジ / C 4 × 7 . 5	SCREW	2
19	167066	座金	WASHER	2
20	211879	当定規	EDGE GUIDE	1
21	211880	バインダー (2 0)	BINDER (20)	1
22	211946	バインダー (2 5)	BINDER (25)	1
23	1202	平ネジ / C 4 × 7	SCREW	1
24	167066	座金	WASHER	1
25	403-9S	テープガイド (組)	TAPE DISC ASSEMBLY	1
26	406	フェルト	FELT	1
27	404	カノコ台	TAPE DISC	1
28	4012	平ネジ / M 4 × 1 2	SCREW	1
29	407	カラ	COLLAR	1
30	408	調節ネジ	ADJUSTING SCREW	1
31	405	取付棒	FIXING ROD	1
32	409	軸	SHAFT	1
33	4818	六角ナット / M 6	NUT	1
34	410	ブラケット	BRACKET	1
35	4908	木ネジ (皿) / 4 . 5	SCREW	3
36	211949	案内板	CORD GUIDE PLATE	1
37	7019	平ネジ / M 4 × 8	SCREW	1
38	413	テープ通シ具	TAPE INSERTING TOOL	1
39	XXXXXX	押エ (組)	PRESSER FOOT COMPLETE	1
*40	277137	ホルダー	HOLDER	1
41	7013	平ネジ / M 3 . 5 × 8	SCREW	1
42	274052	ネジリバネ	SPRING	1
43	7009	平ネジ / M 3 × 5	SCREW	1
44	212059-B	ピン	PIN	1
45	212668	補助板	EUXILIARY PLATE	1
46	5030	平ネジ / C 1 × 2 . 3	SCREW	1
47	XXXXXX	押エ (組)	PRESSER FOOT COMPLETE	1
*48	277136A	ホルダー	HOLDER	1
49	274057	ネジリバネ	SPRING	1

XXXXXXはゲージパーツです。

52-57頁のゲージパーツ表で確認してください。

XXXXXX is one of the gauge parts.

Please confirm the correct part by the gauge parts lists on pages 52-57.

オプション (Option)

EXT5204-02
 EXT5214-03,54S1,M03
 EXT5214H-55

EXT3215-02,03,04
 EXT3216
 EXT3215H-05
 EXT3216H
 EXT3244-03,04
 EXT3244H-05

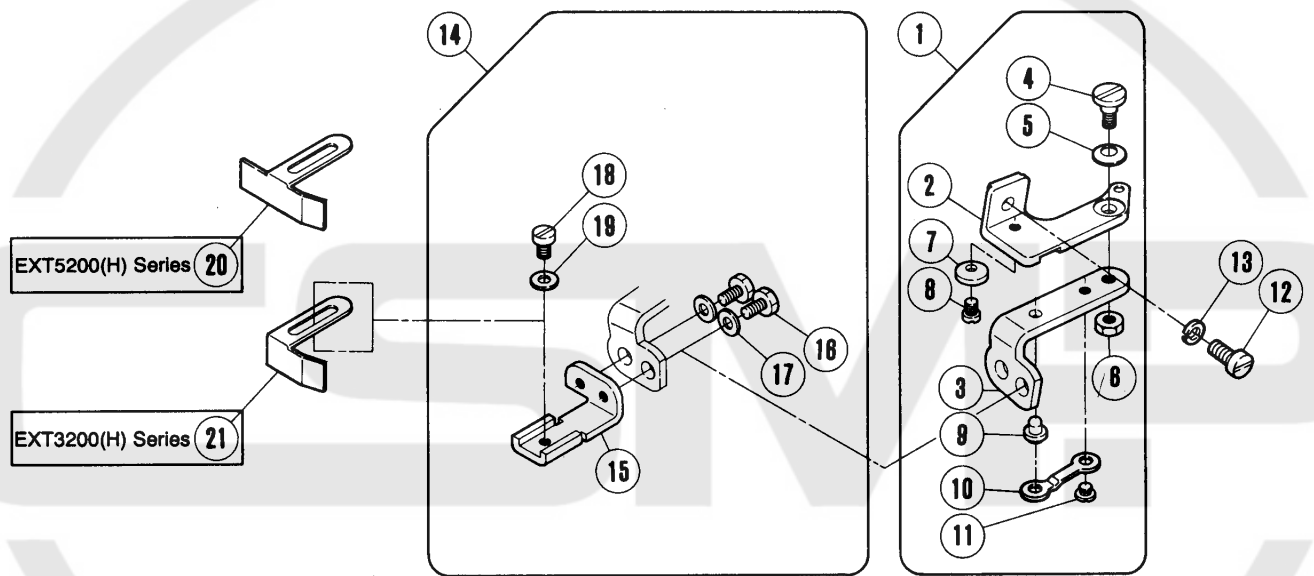

REF. NO.	PART NO. 部品番号	名称	NAME	QT.
1	210685	定規ブラケット (組)	CLOTH GUIDE BRACKET ASSEMBLY	1
2	210680	定規ブラケット	CLOTH GUIDE BRACKET	1
3	210681	ヒンジ/定規ブラケット	HINGE/EDGE GUIDE BRACKET	1
4	5184	段付ネジ/C 5	SCREW	1
5	201191	皿バネ	SPRING	1
6	3044	六角ナット/C 5	NUT	1
7	210682	ストッパー/ヒンジ	STOPPER	1
8	5053	平ネジ/C 4 × 4. 8	SCREW	1
9	210683	段付ピン	PIN	1
10	210684	板バネ	FLAT SPRING	1
11	2906	平ネジ/C 4 × 2. 6	SCREW	1
12	7020	平ネジ/M 4 × 1 0	SCREW	1
13	201252	バネ座金	SPRING WASHER	1
14	210686	当定規台 (組)	BRACKET COMPLETE/EDGE GUIDE	1
15	210687	当定規台	BRACKET/EDGE GUIDE	1
16	5088	六角ネジ/C 4 × 7. 5	SCREW	1
17	167066	座金	WASHER	1
18	1202	平ネジ/C 4 × 7	SCREW	1
19	167066	座金	WASHER	1
20	204667	当定規	EDGE GUIDE	1
21	201233A	当定規	EDGE GUIDE	1

EXT3216
EXT3215-02/223(K)

EXT3216
EXT3215-03/233(K)

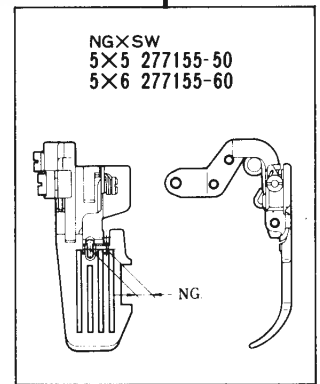
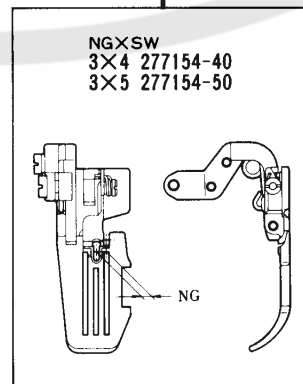
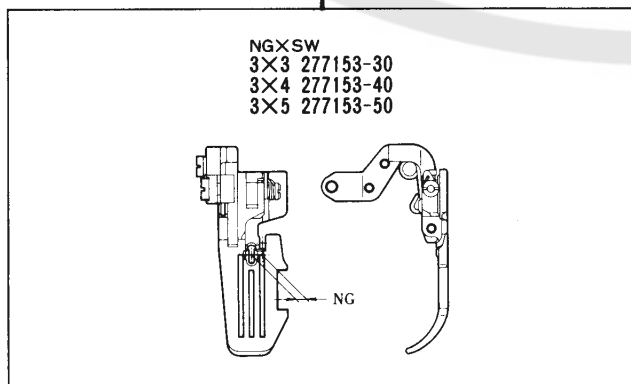
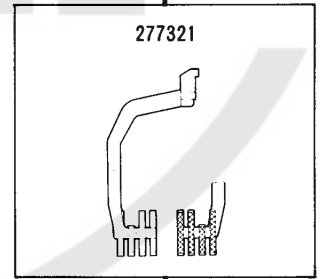
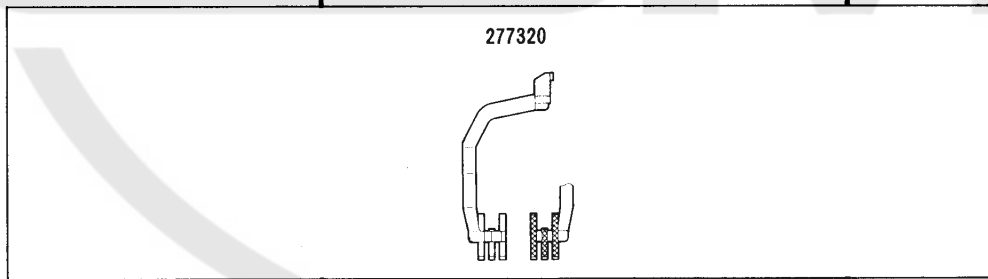
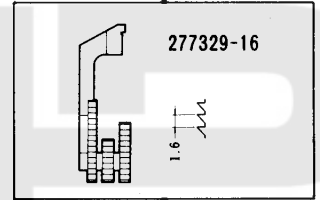
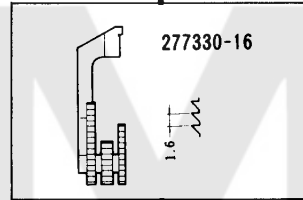
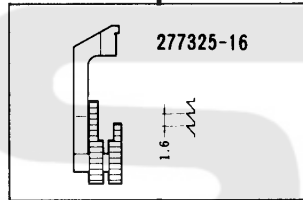
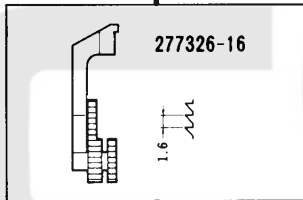
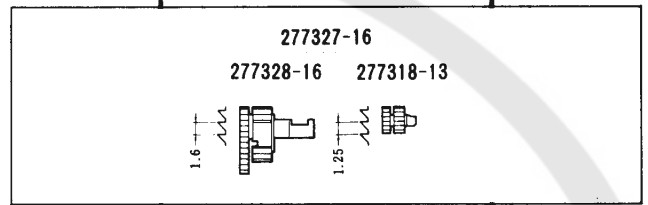
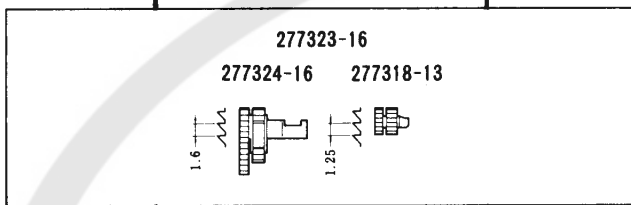
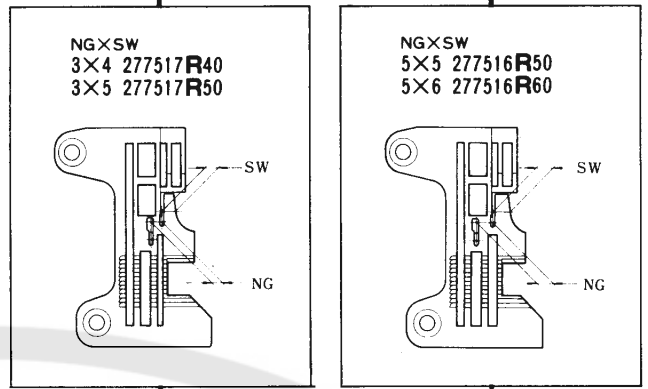
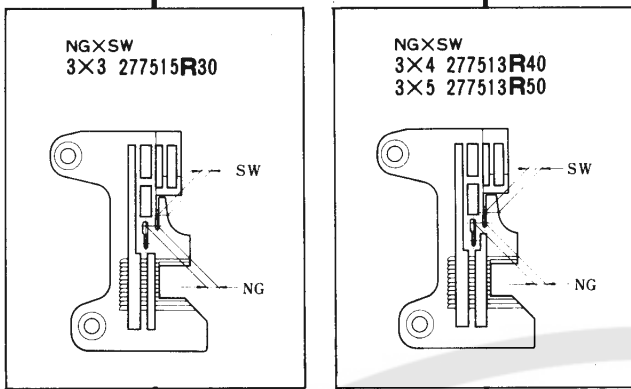

EXT3216
EXT3215-02/223(K)

EXT3216
EXT3215-03/233(K)

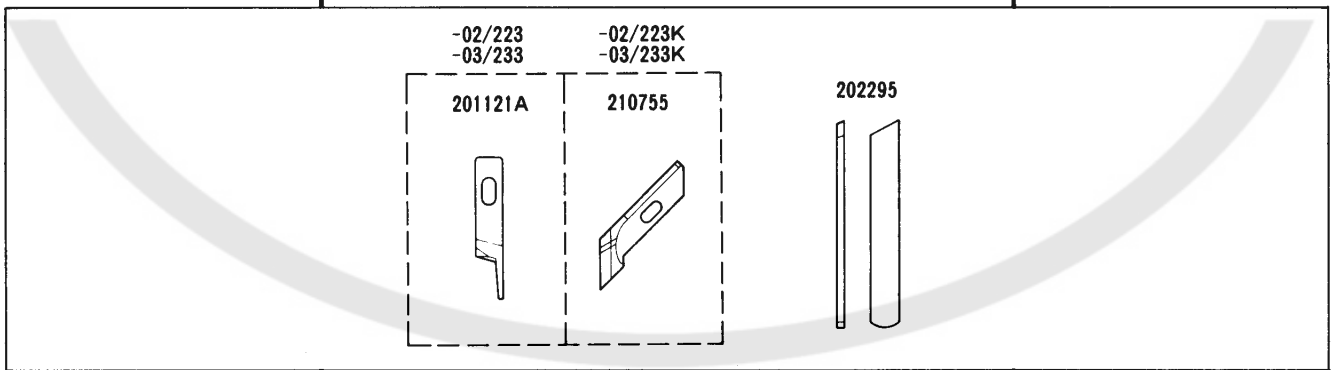
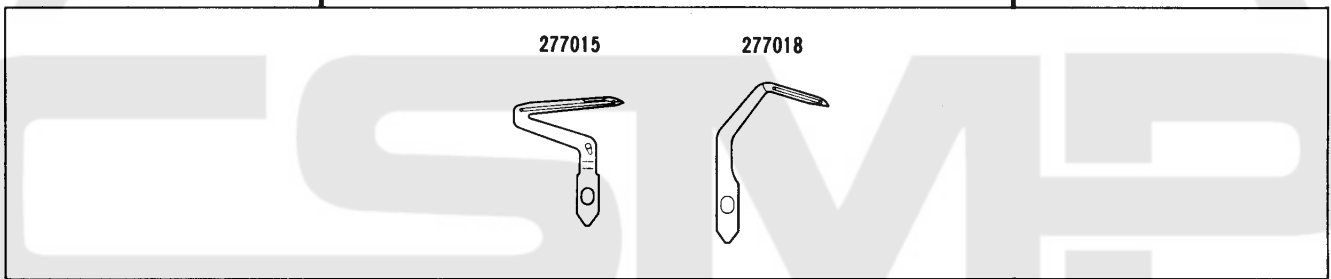
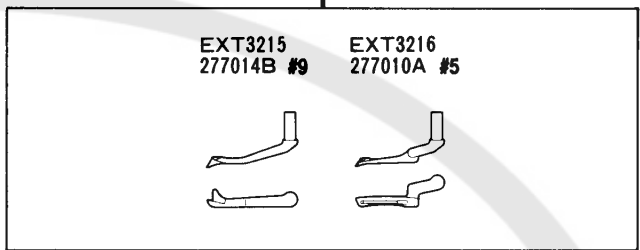
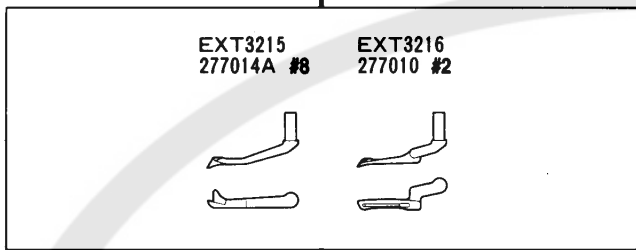
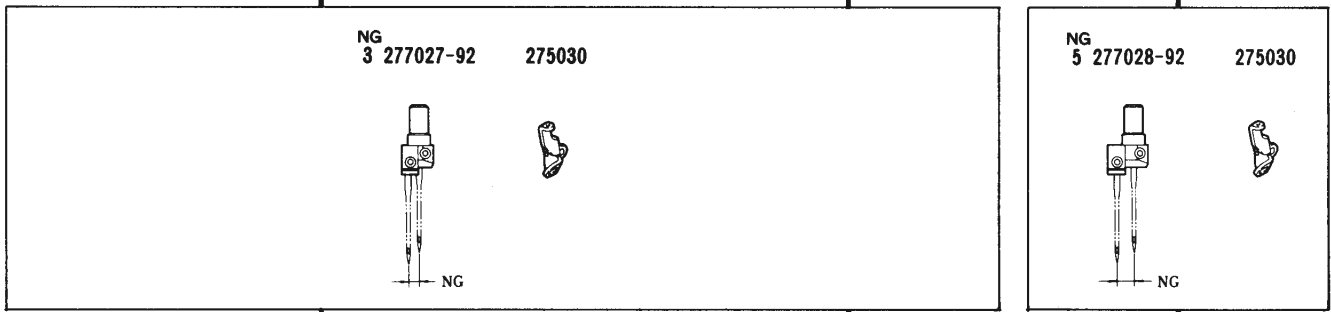

地縫用(薄生地)
PLAIN SEAMING
(LIGHT FABRIC)

地縫用(中厚生地)
PLAIN SEAMING
(MEDIUM FABRIC)

EXT3200 Series 共通部品
COMMON PARTS



EXT3216
EXT3215^{04/435K}

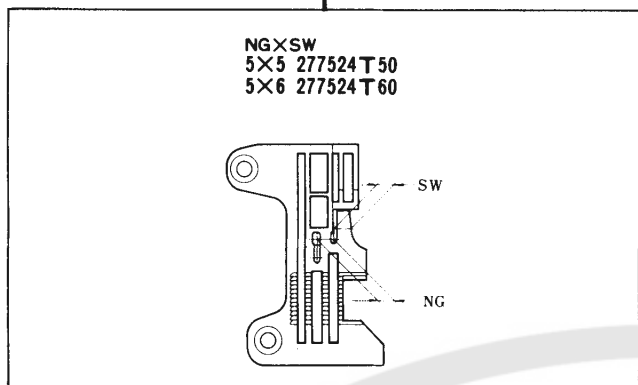

EXT3216H
EXT3215H^{05/535K}

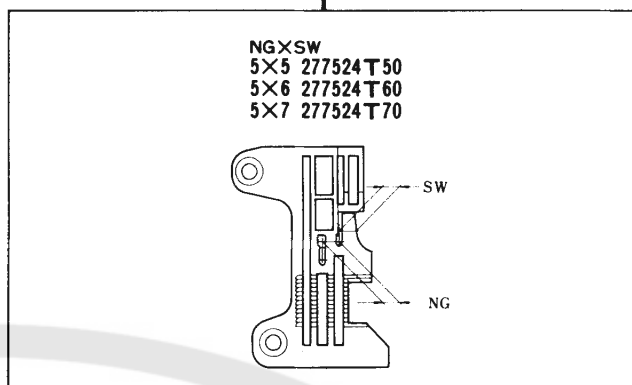

277337-25
277338-25 277318-13

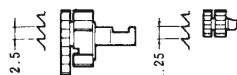

277339-25

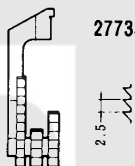

277343-20

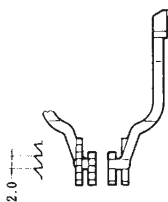

NGXSW
5×5 277156-50
5×6 277156-60

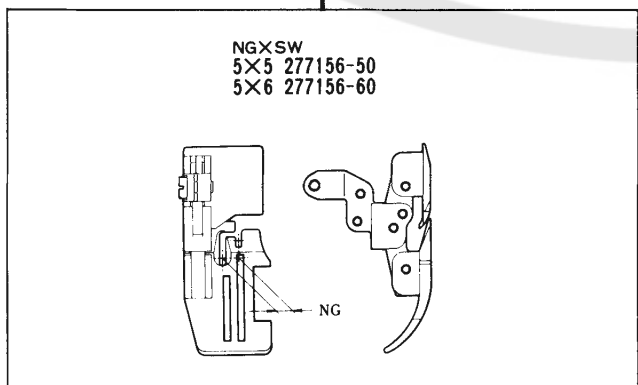

NGXSW
5×5 277156-50
5×6 277156-60
5×7 277156-70

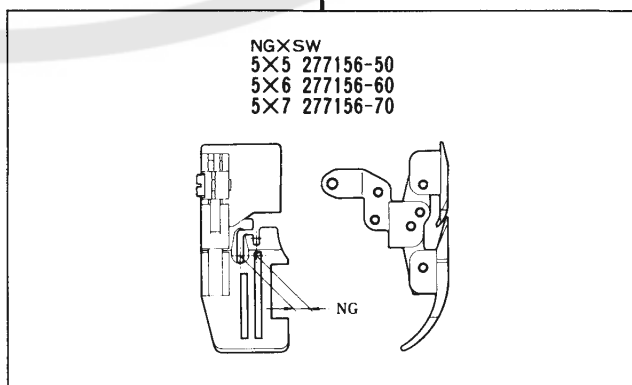

EXT3216
EXT3215-04/435K

EXT3216H
EXT3215H-05/535K

NG
5 277029-92 275030A

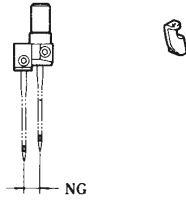

EXT3215
277014 #1

EXT3216
277011 #3

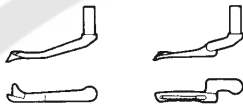

EXT3215
277014A #8

EXT3216
277017 #11



277015

277018-C

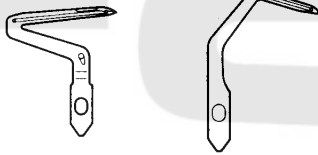

277015A

277018-C

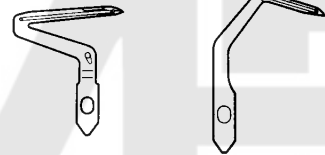

211662

277009

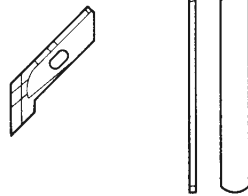

地縫用(厚生地)
PLAIN SEAMING
(HEAVY FABRIC)

地縫用(極厚生地)
PLAIN SEAMING
(EXTRA HEAVY FABRIC)

EXT3244-03/333(K)

EXT3244-04/435K

EXT3244H-05/535K

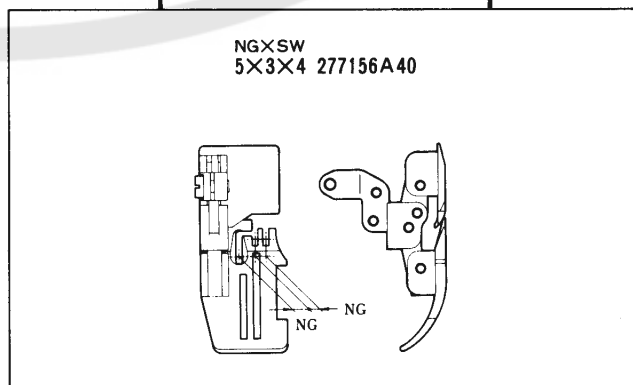
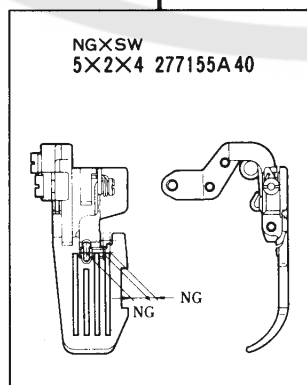
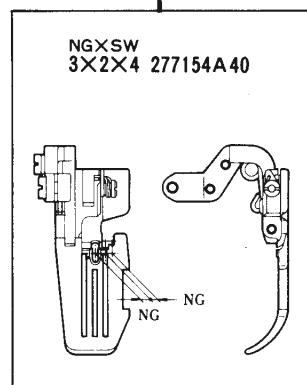
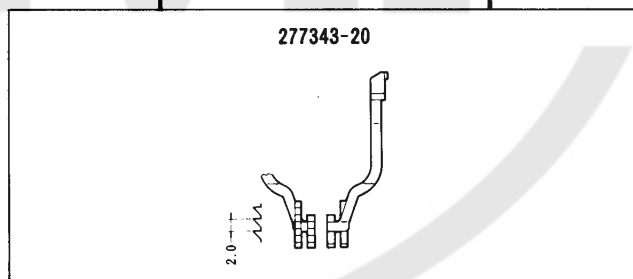
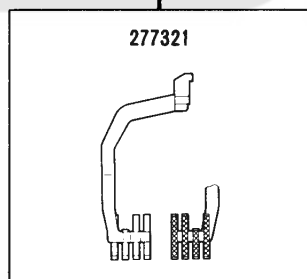
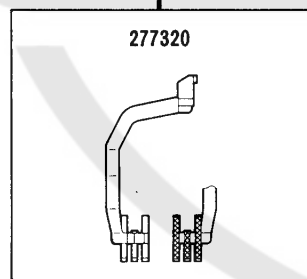
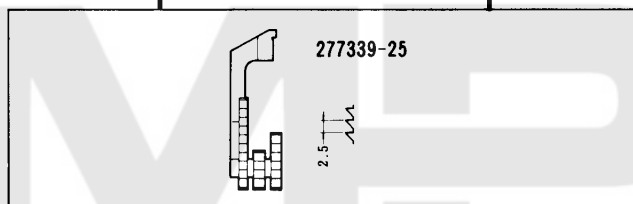
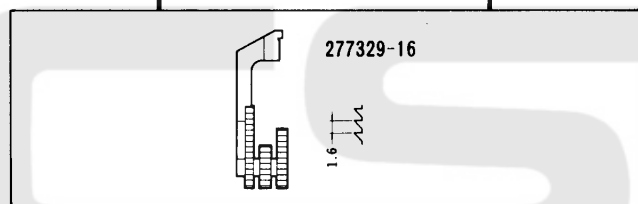
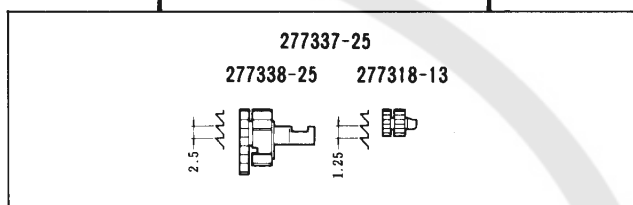
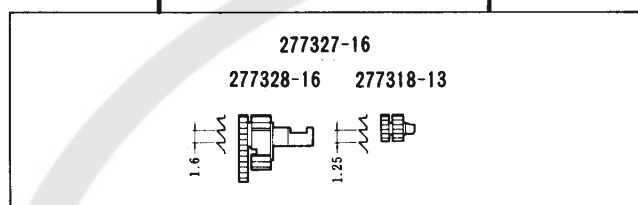
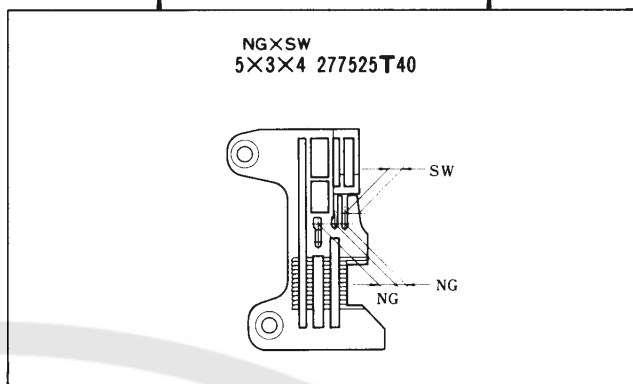
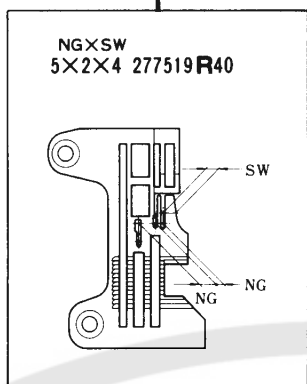
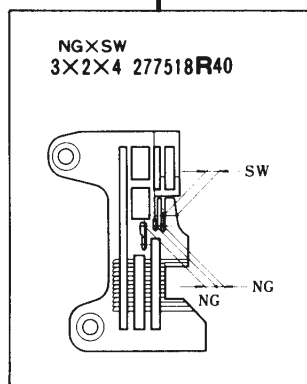

EXT3244-03/333(K)

EXT3244-04/435K

EXT3244H-05/535K

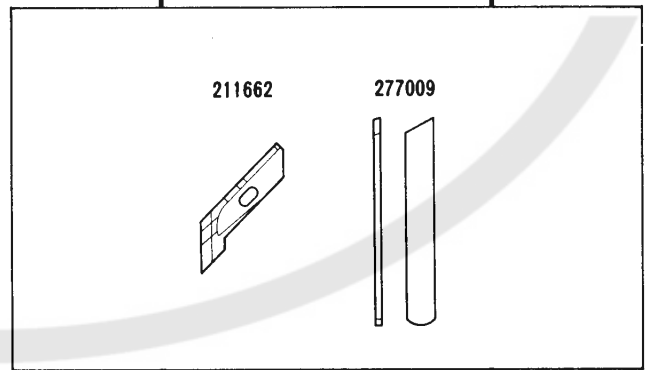
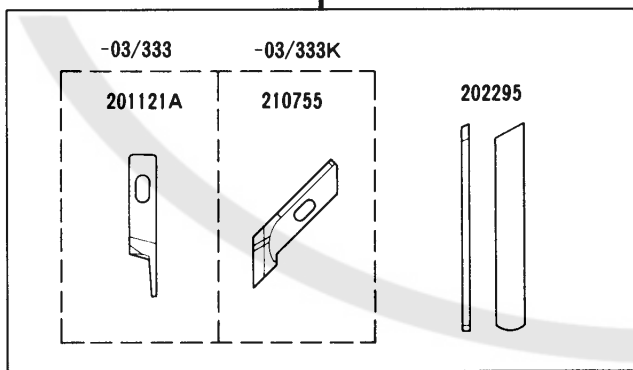
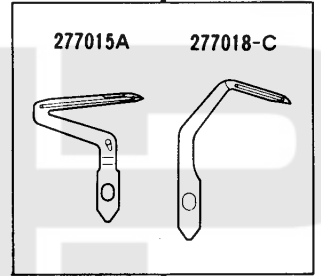
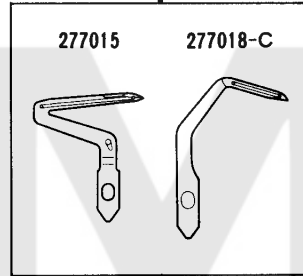
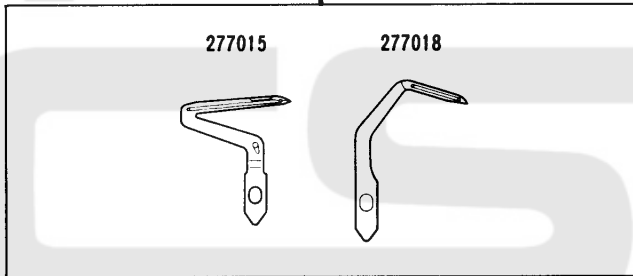
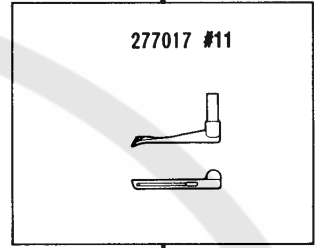
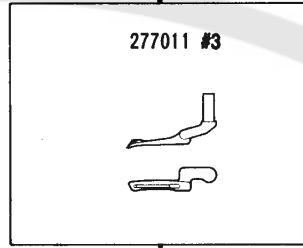
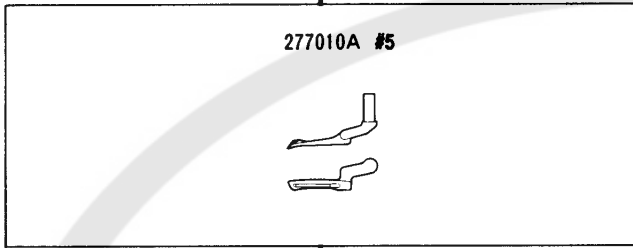
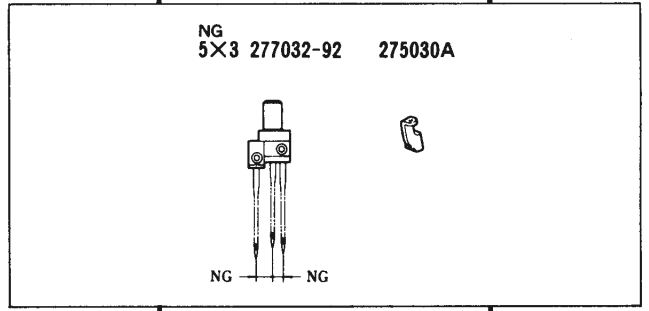
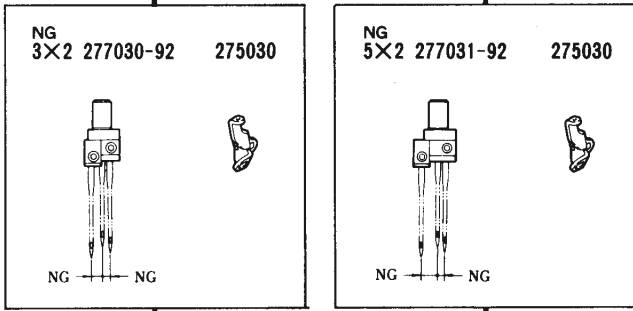

地縫用(中厚生地)
PLAIN SEAMING
(MEDIUM FABRIC)

地縫用(厚生地)
PLAIN SEAMING
(HEAVY FABRIC)

地縫用(極厚生地)
PLAIN SEAMING
(EXTRA HEAVY FABRIC)

EXT3216
EXT3215-42/233(K)

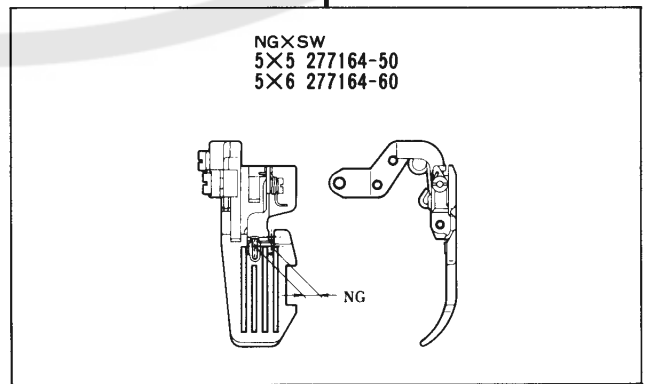
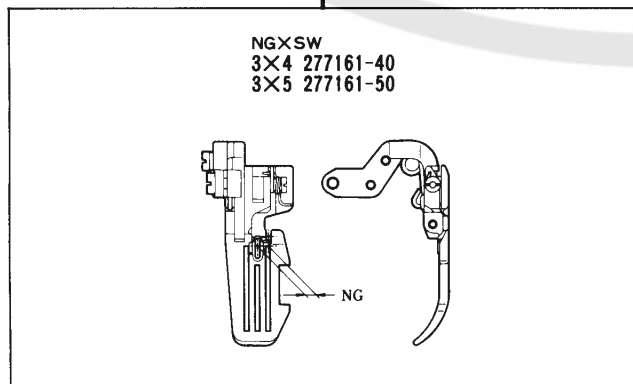
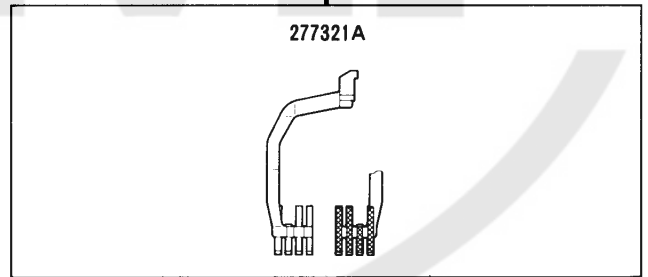
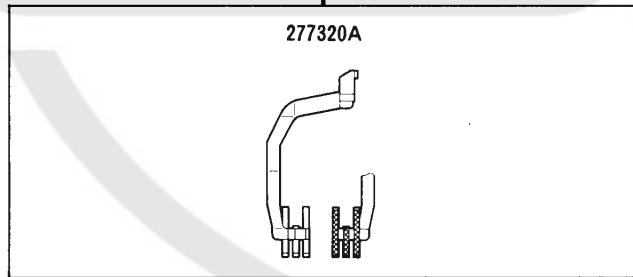
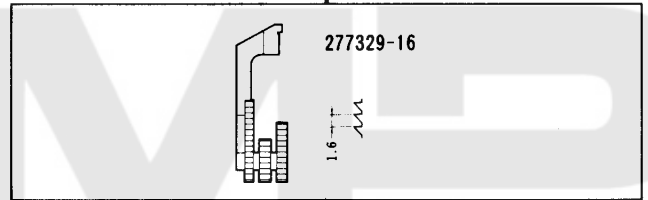
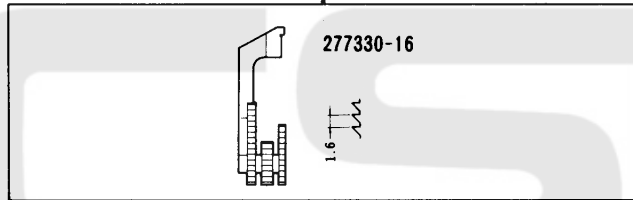
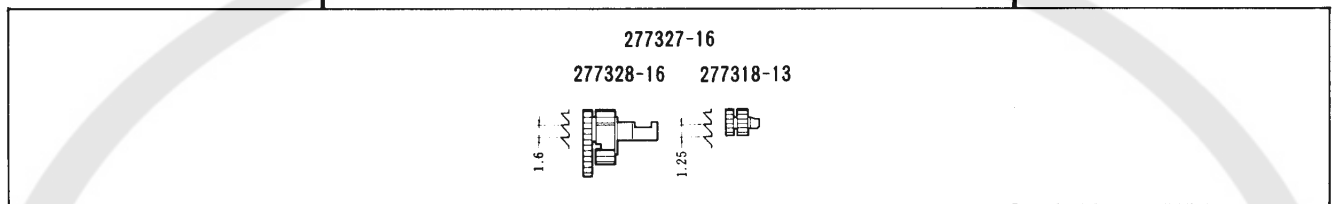
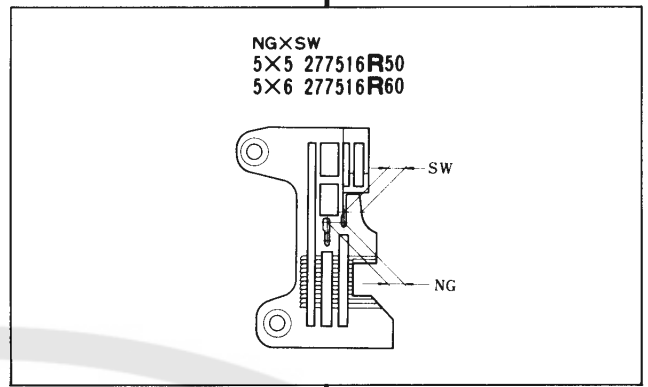
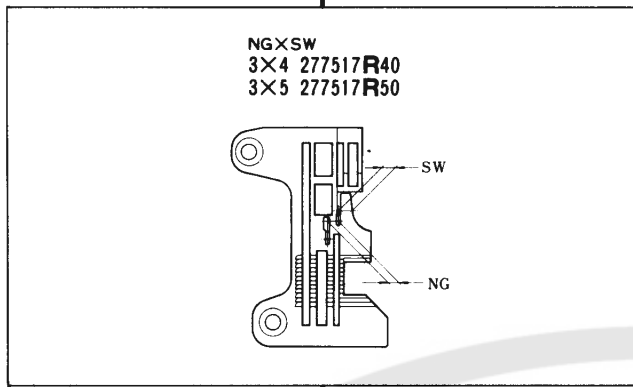

EXT3216-42/233(K)
EXT3215

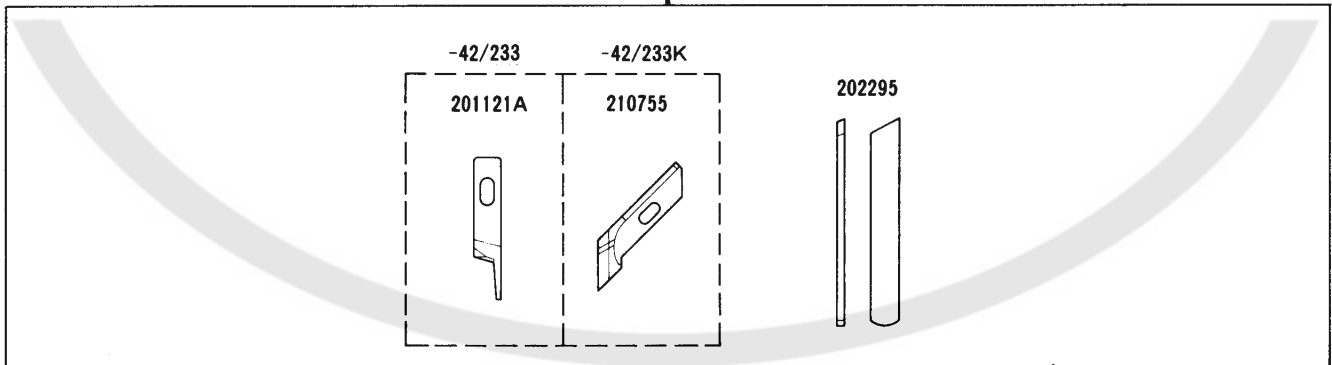
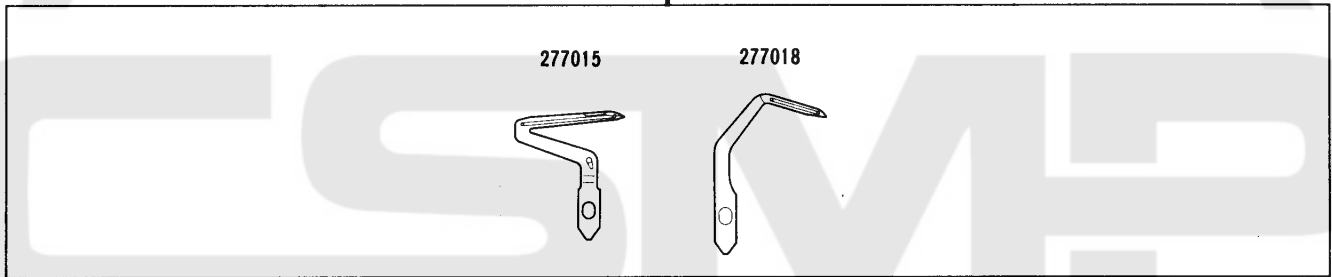
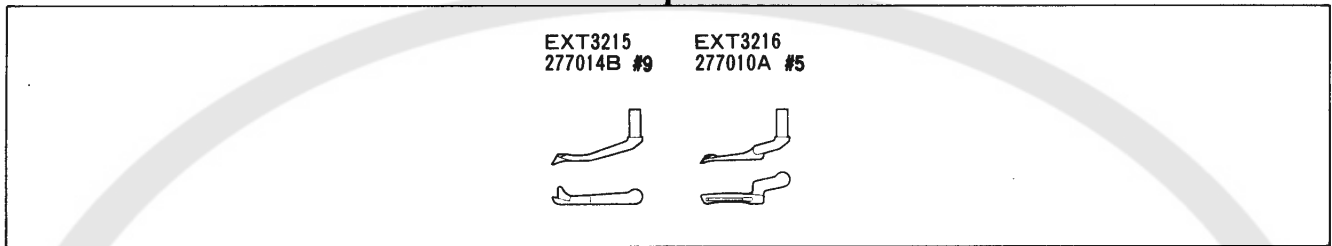
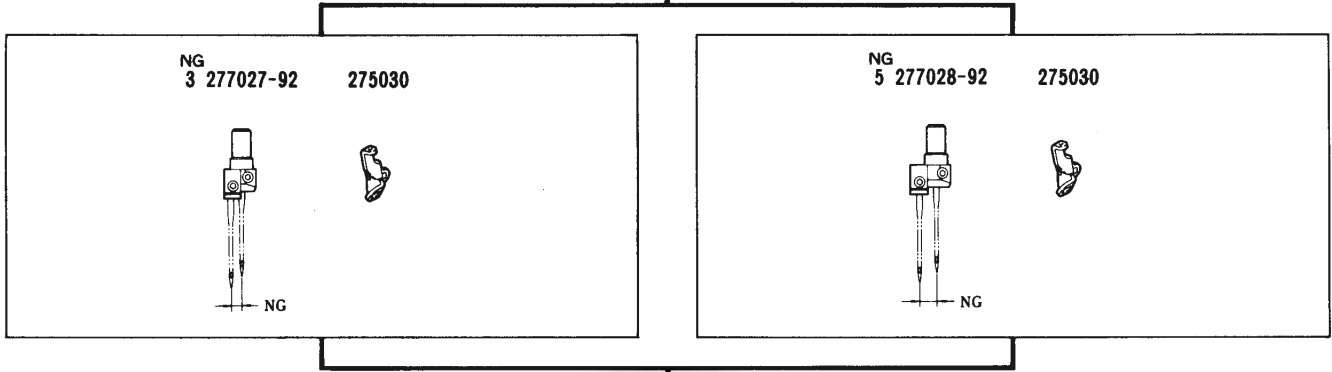

ヒダ取り用(薄生地)
SHIRRING
(LIGHT FABRIC)

EXT3215・3216-C3P1/233(K)
EXT3215・3216-C3P2/233(K)

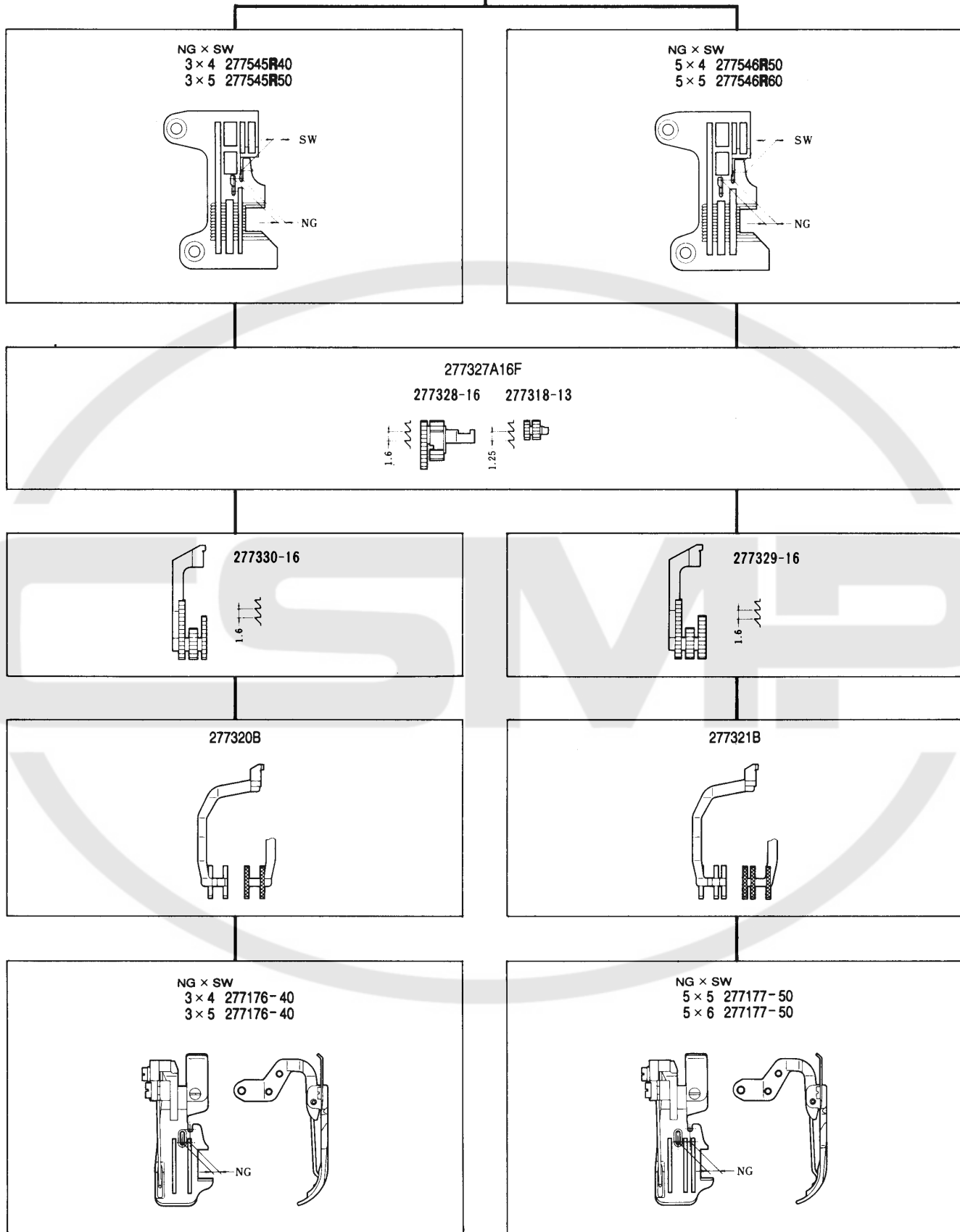

EXT3215•3216-C3P1/233(K)
EXT3215•3216-C3P2/233(K)

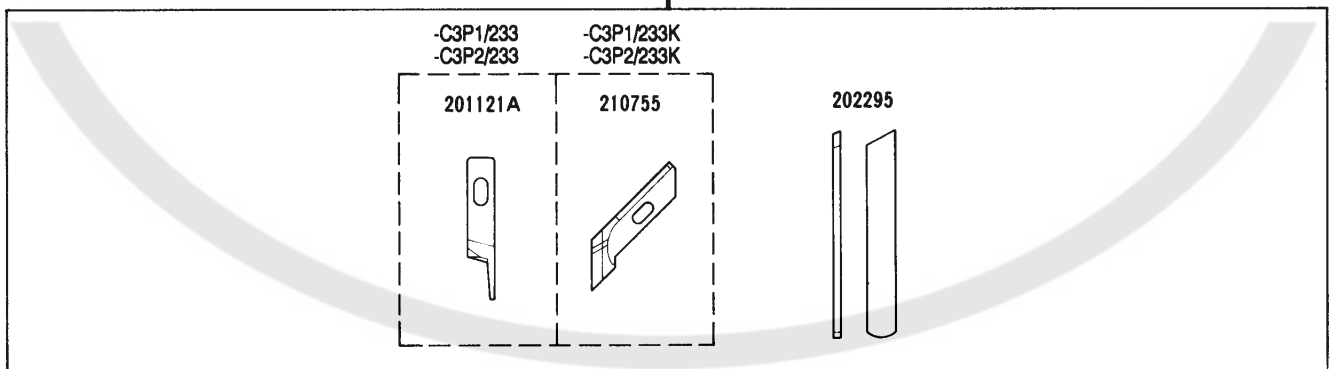
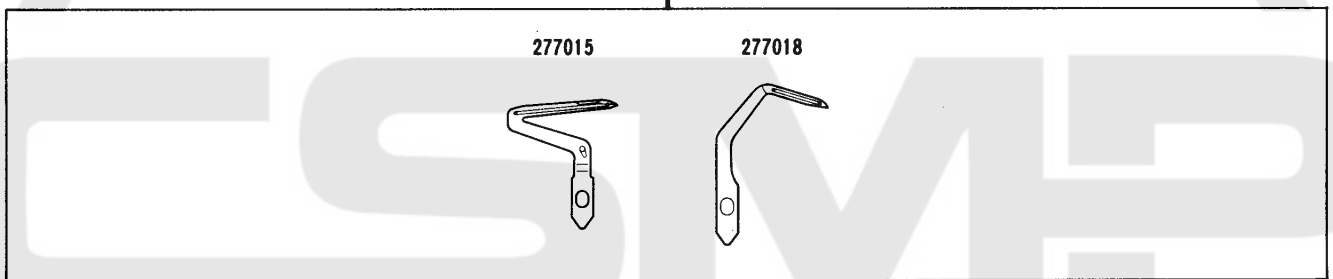
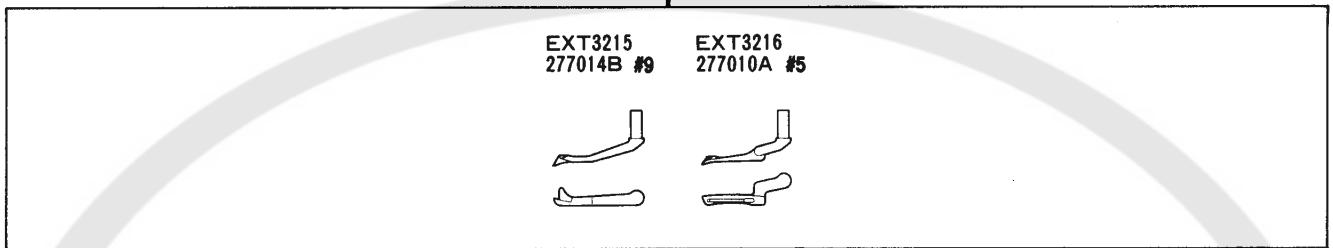
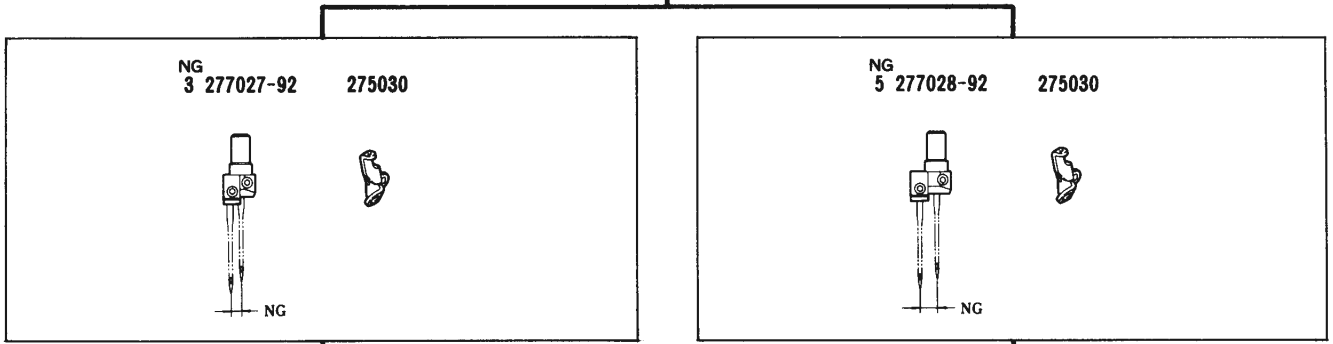

パイピング用(中厚生地)
PIPING
(MEDIUM FABRIC)

EXT5204-02/233(K)

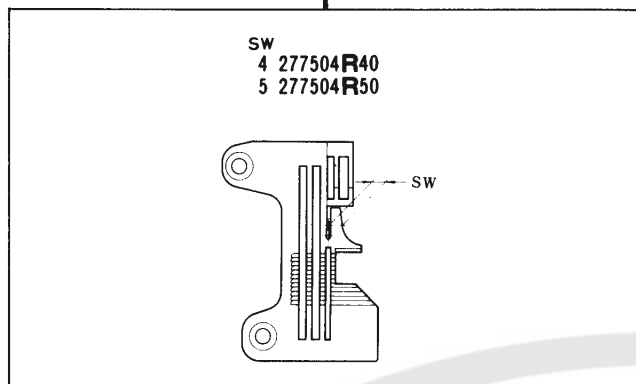

EXT5214-03/333(K)
EXT5214-M03/333(K)

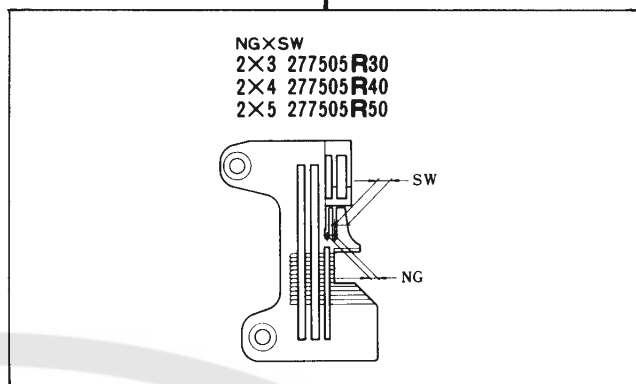

277303-16F
277304-16F 277318-13

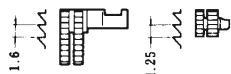

277305-16F

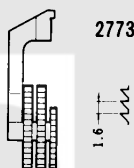

277344

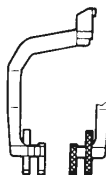

SW
4 277149-40
5 277149-50

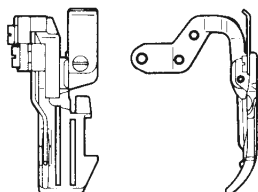

NGXSW
2X3 277150-30
2X4 277150-40
2X5 277150-50

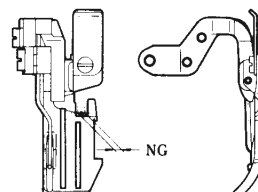

EXT5204-02/233(K)

EXT5214-03/333(K)
EXT5214-M03/333(K)

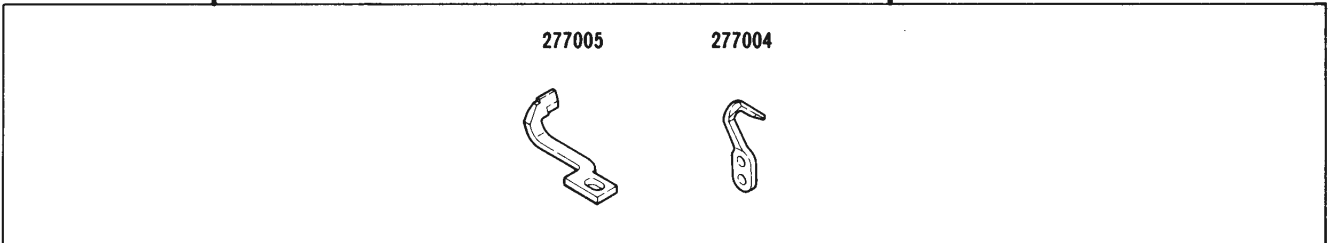
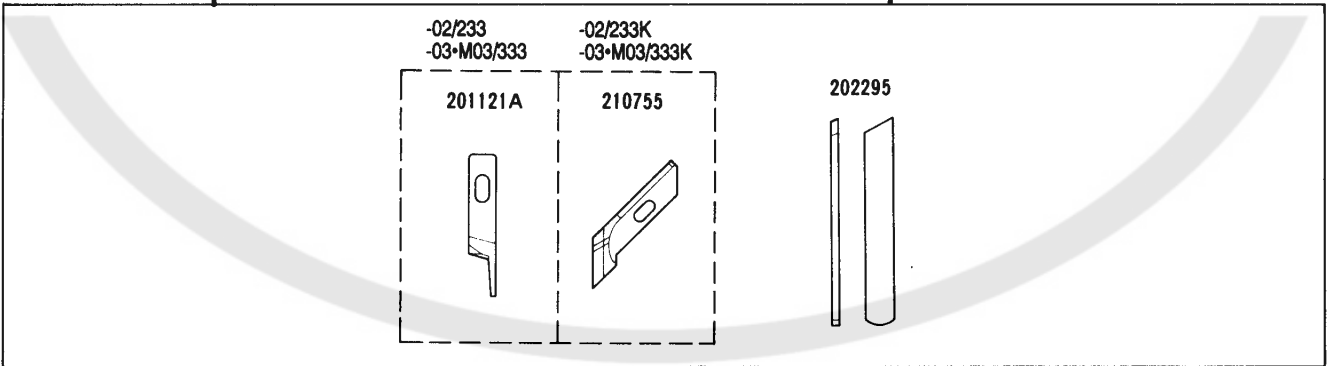
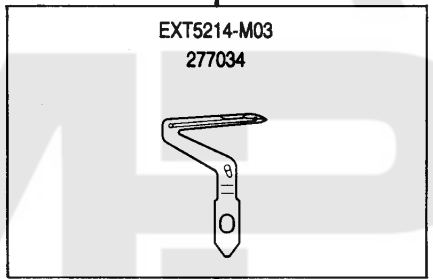
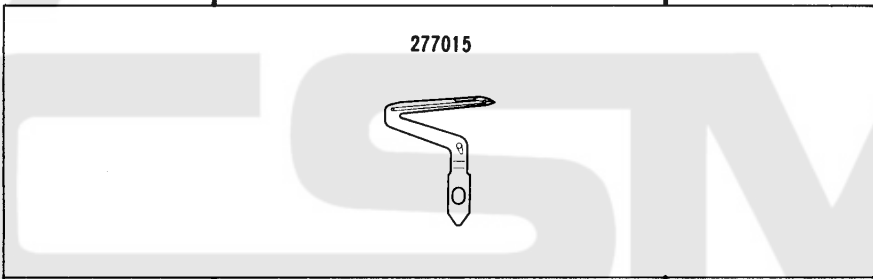
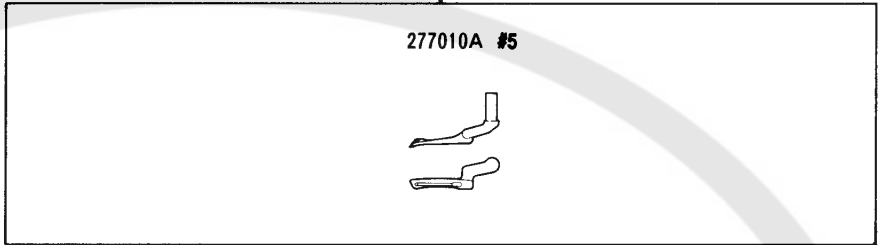
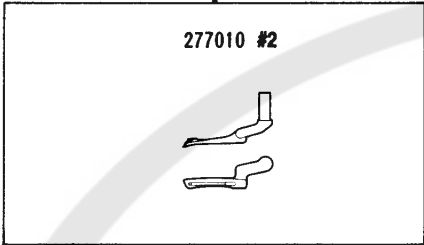
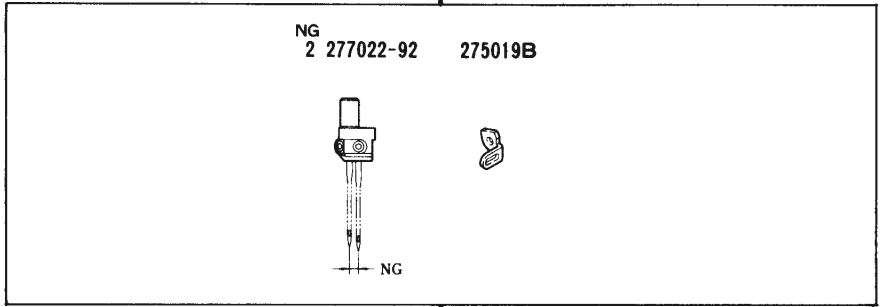
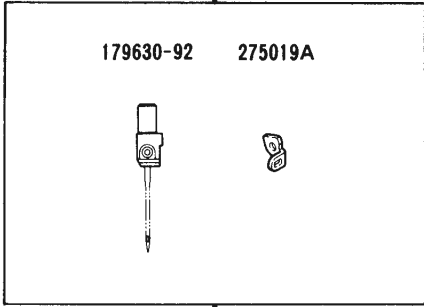

地縫用(薄生地)
PLAIN SEAMING
(LIGHT FABRIC)

地縫用(中厚生地)
PLAIN SEAMING
(MEDIUM FABRIC)

EXT5204-12/223(K)

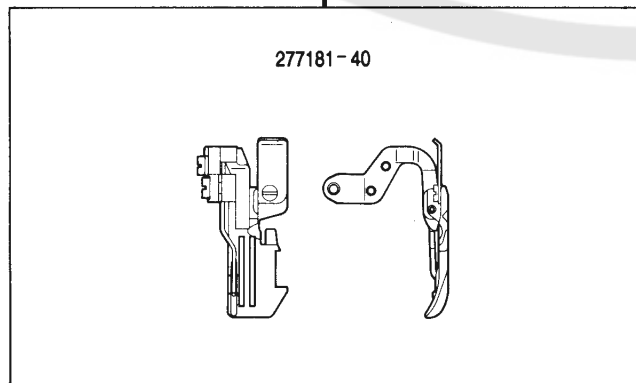
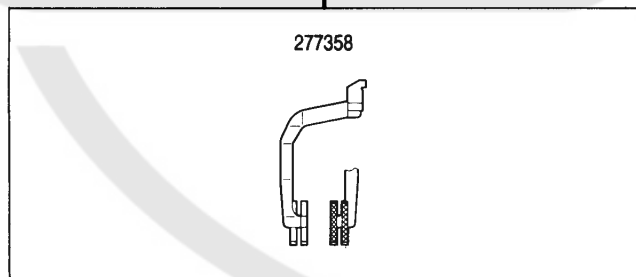
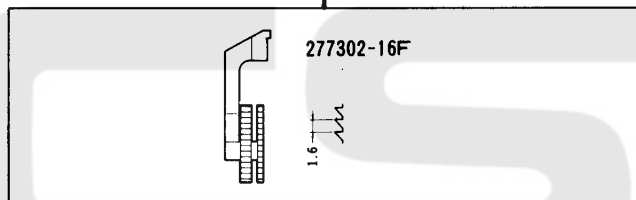
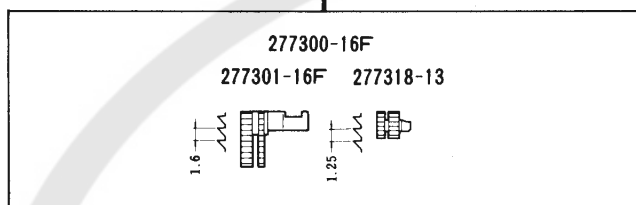
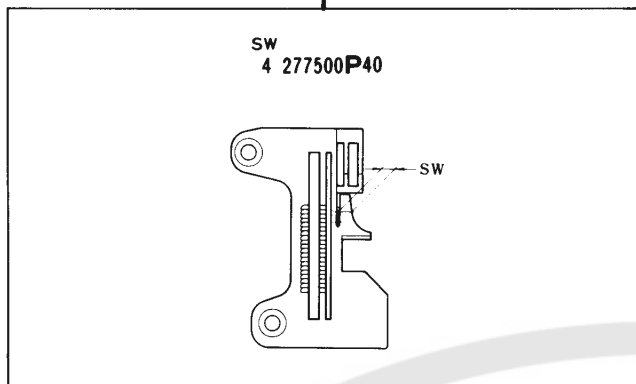

EXT5214-43/333(K)

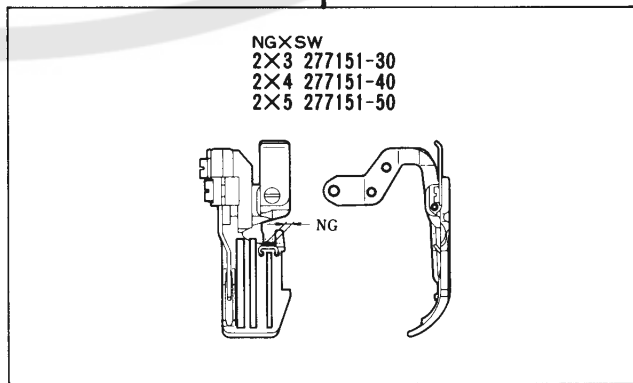
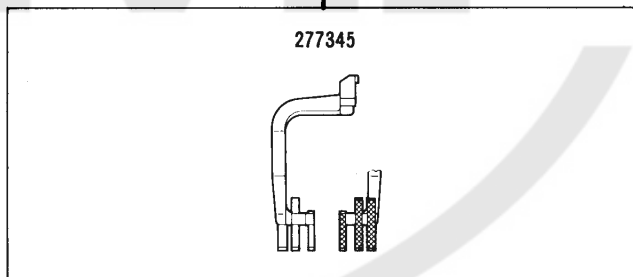
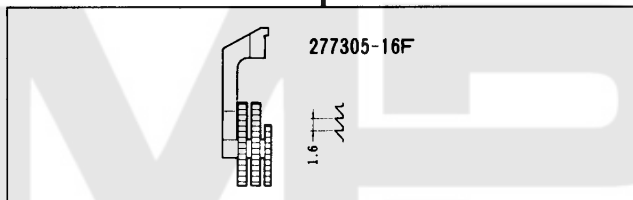
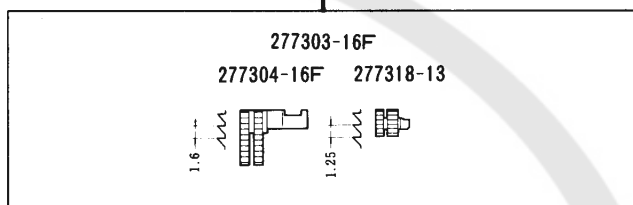
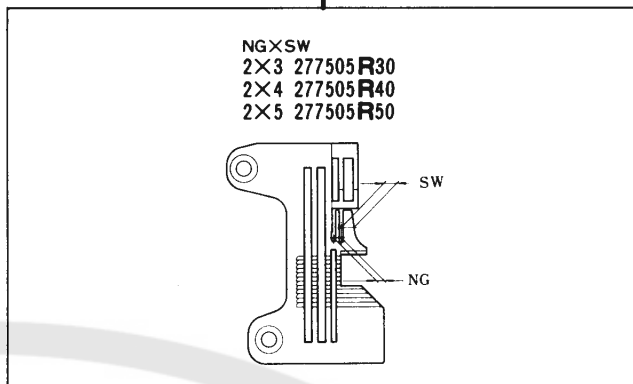

EXT5204-12/223(K)

EXT5214-43/333(K)

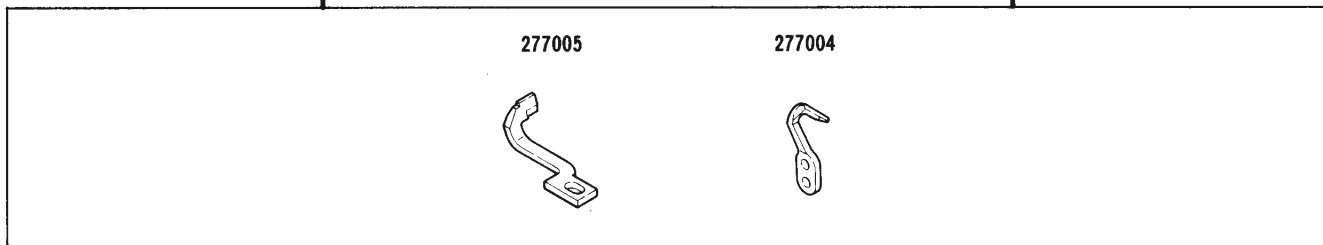
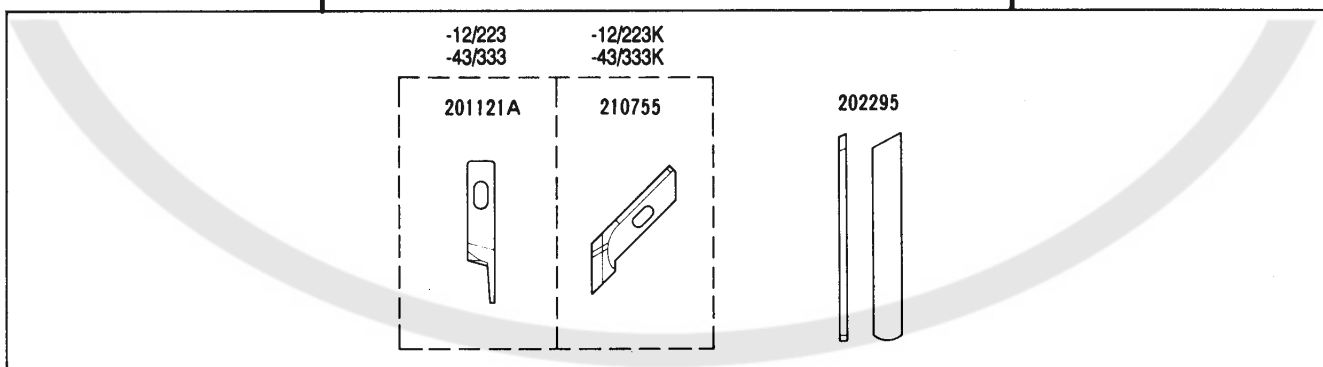
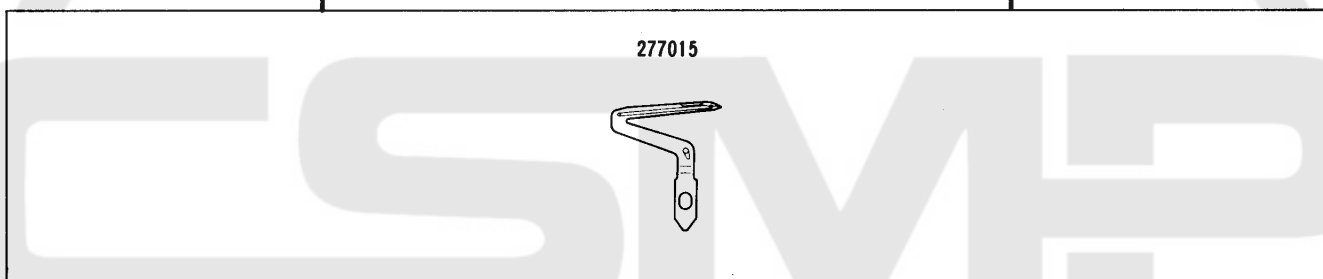
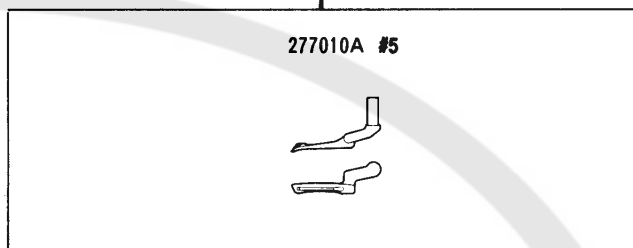
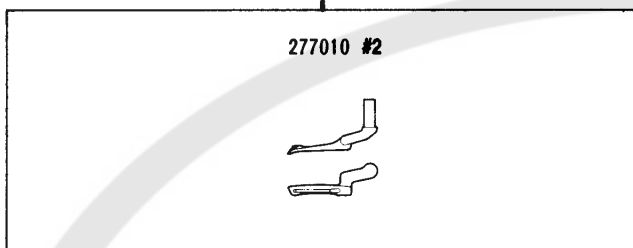
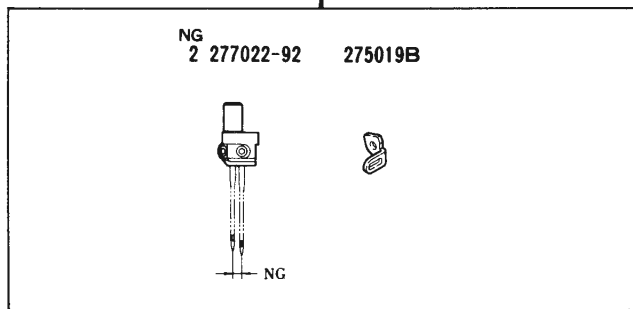
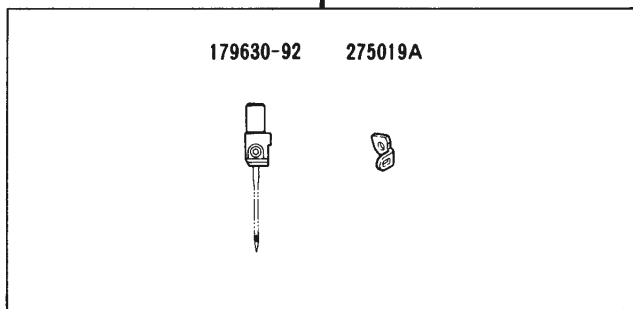

裾引用(薄生地)
BLINDSTITCH HEMMING
(LIGHT FABRIC)

ヒダ取り用(中厚生地)
SHIRRING
(MEDIUM FABRIC)

EXT5214-54S1/433(K)
EXT5214-54S2/433(K)

EXT5214-54S1/443(K)
EXT5214-54S2/443(K)

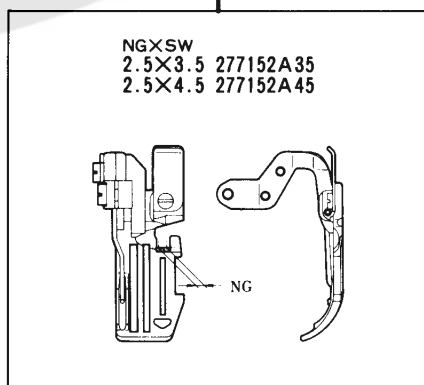
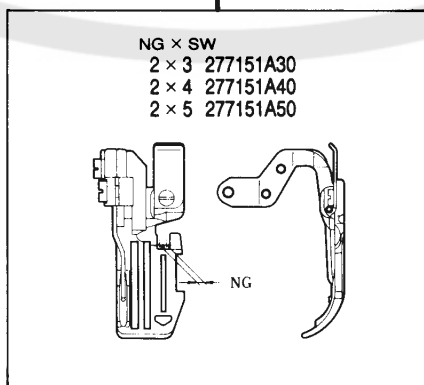
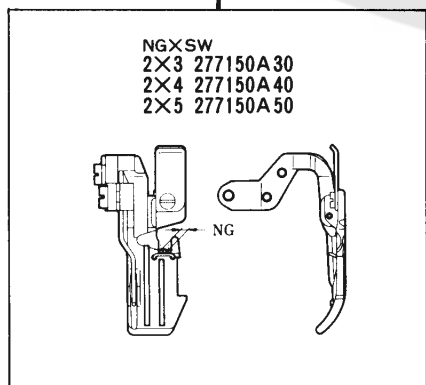
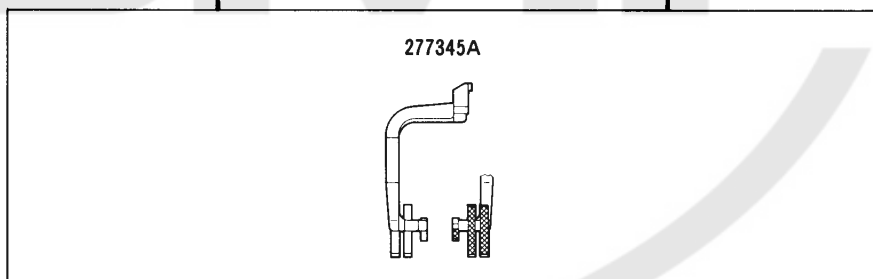
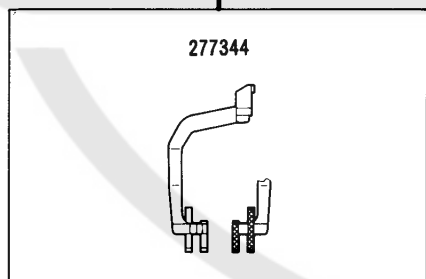
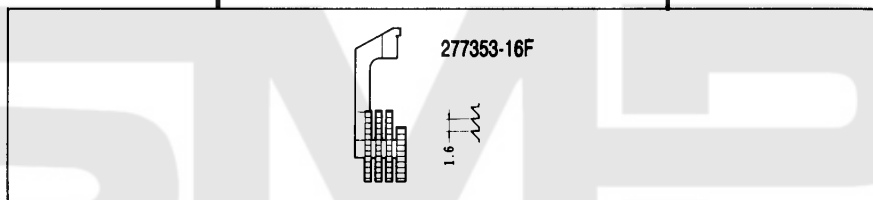
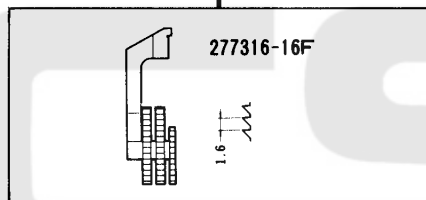
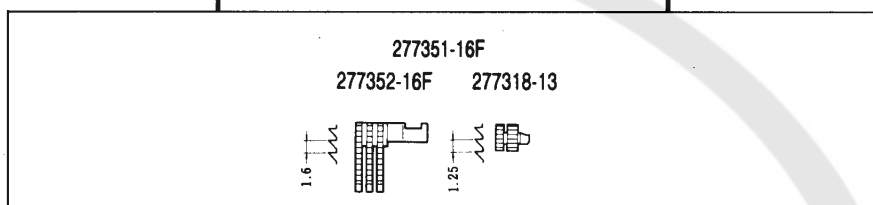
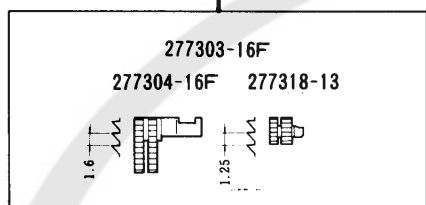
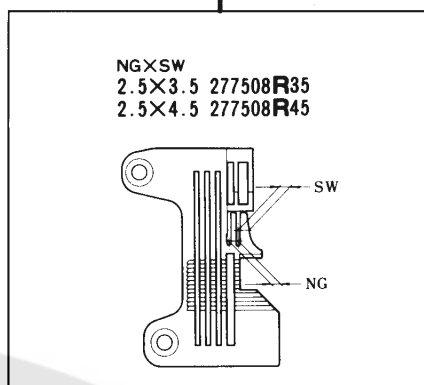
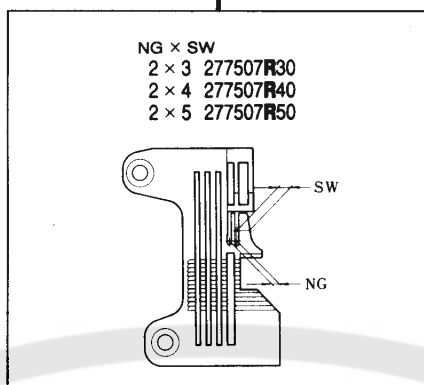
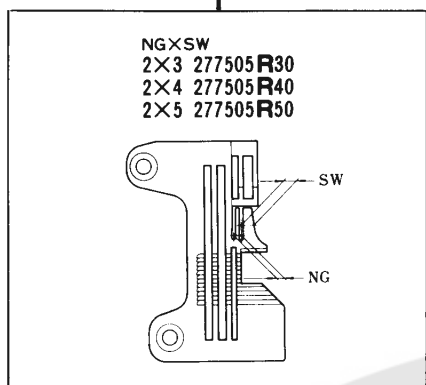

EXT5214-54S1/433(K)
EXT5214-54S2/433(K)

EXT5214-54S1/443(K)
EXT5214-54S2/443(K)

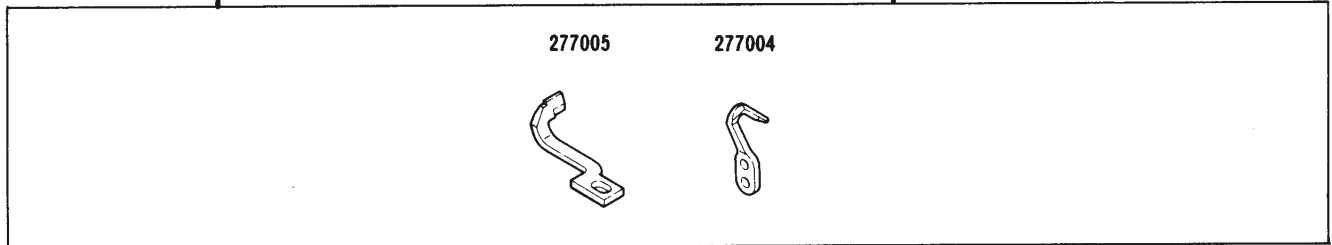
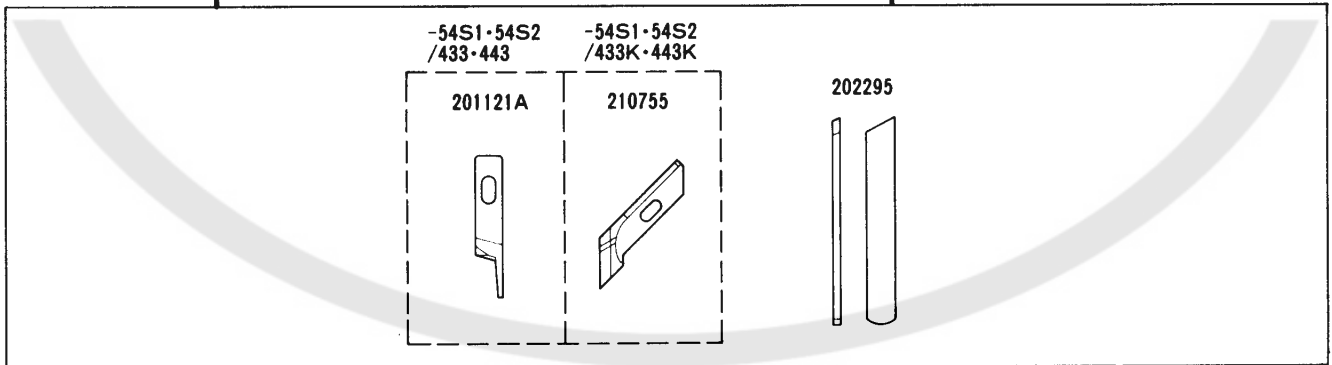
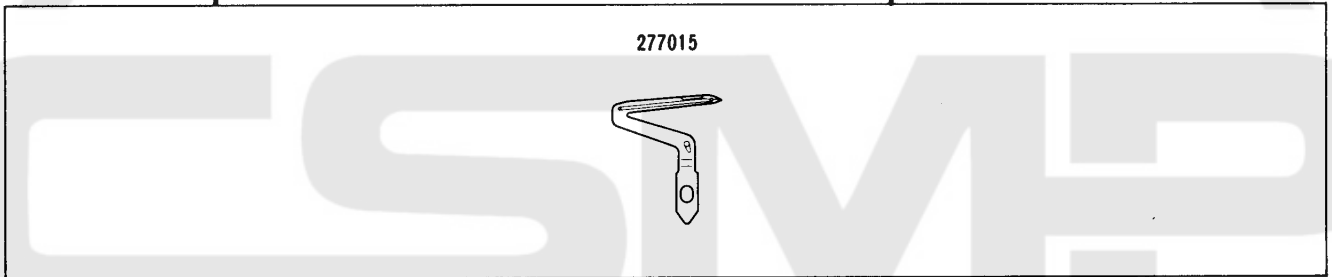
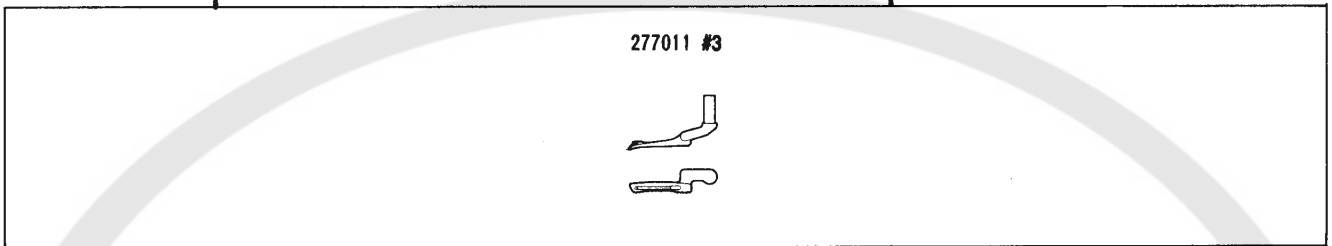
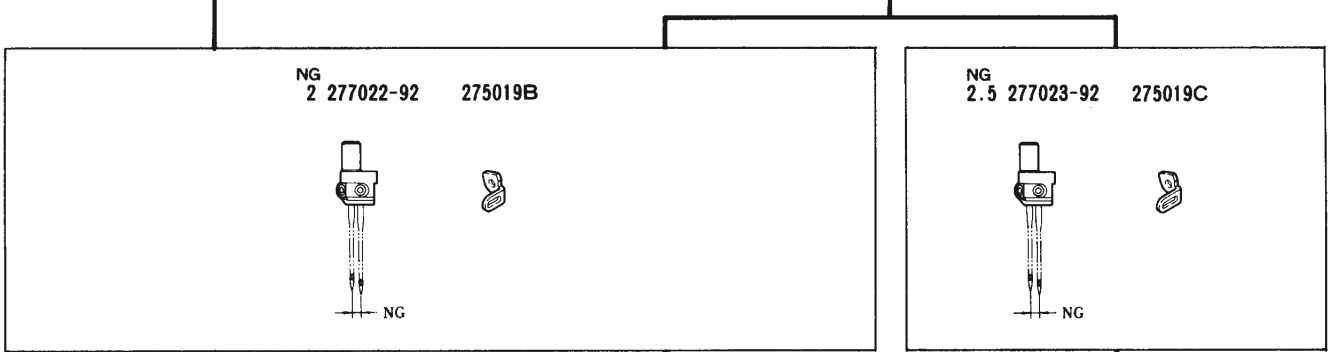

テープ付用(厚生地)
ATTACHING TAPE
(HEAVY FABRIC)

テープ付用(厚生地)
ATTACHING TAPE
(HEAVY FABRIC)

EXT5214H-55/545(K)

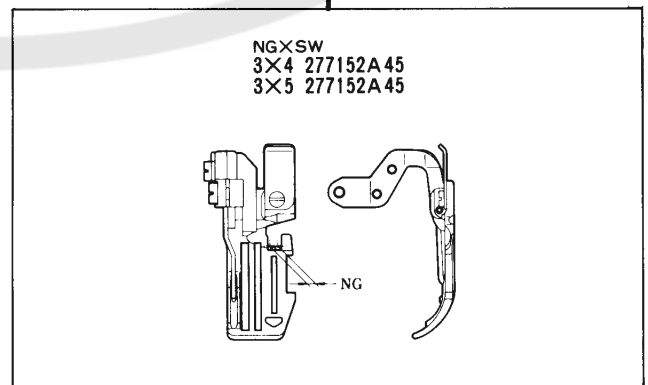
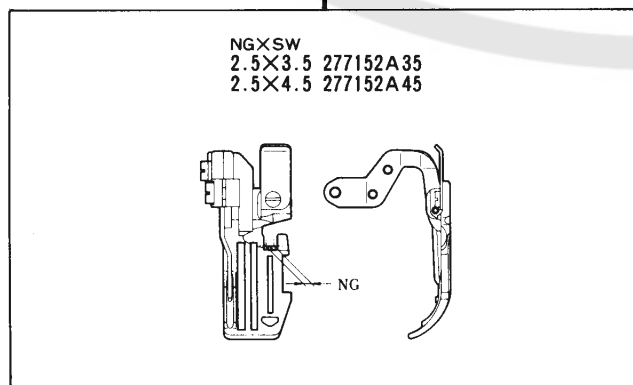
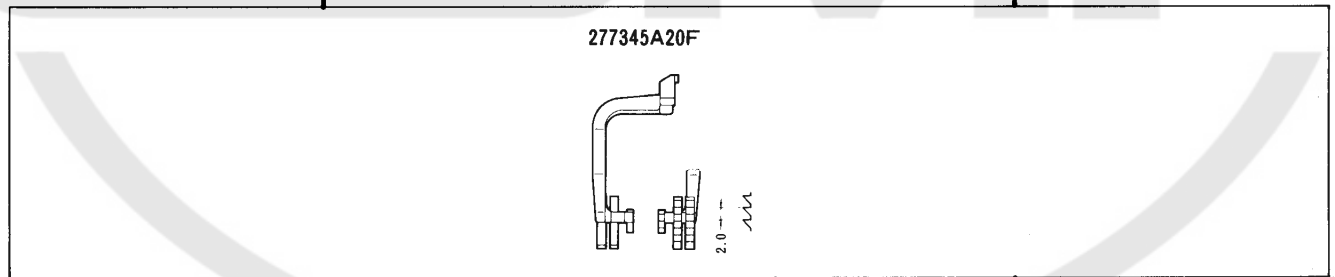
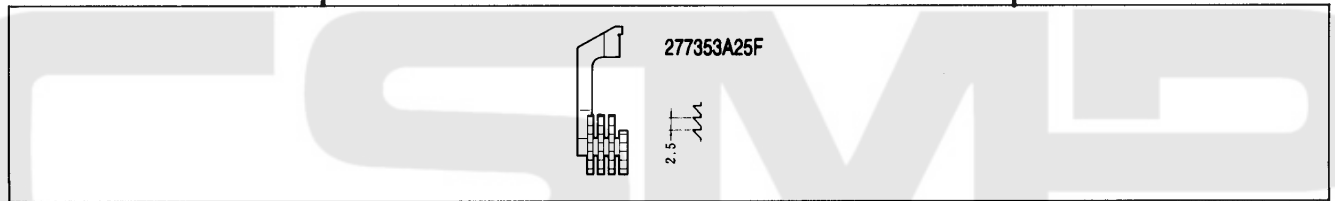
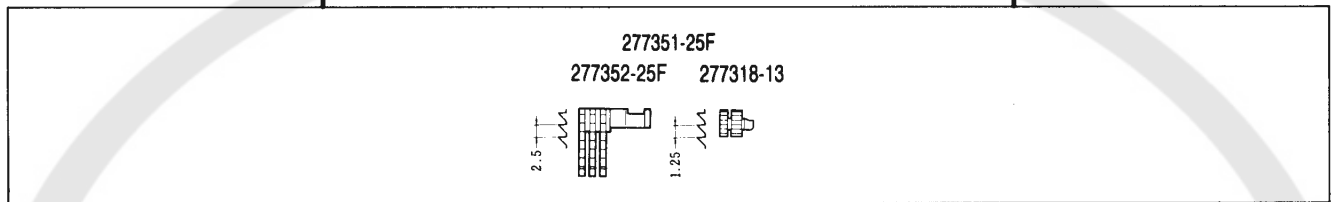
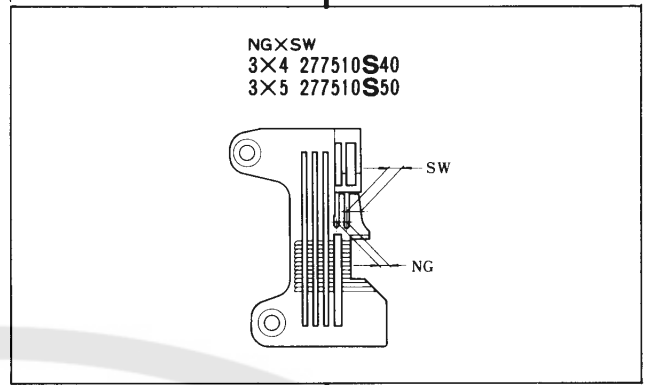
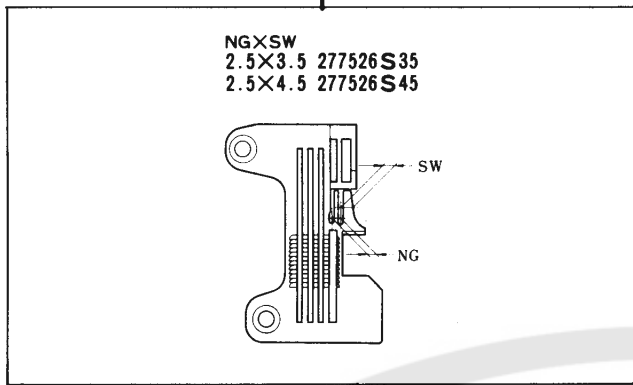

EXT5214H-55/545(K)

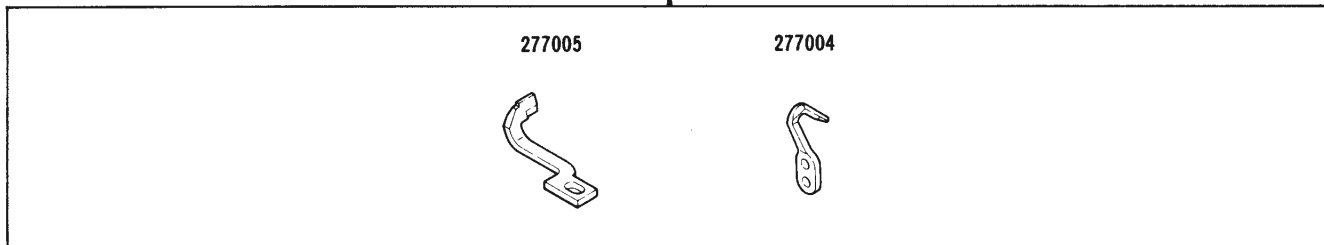
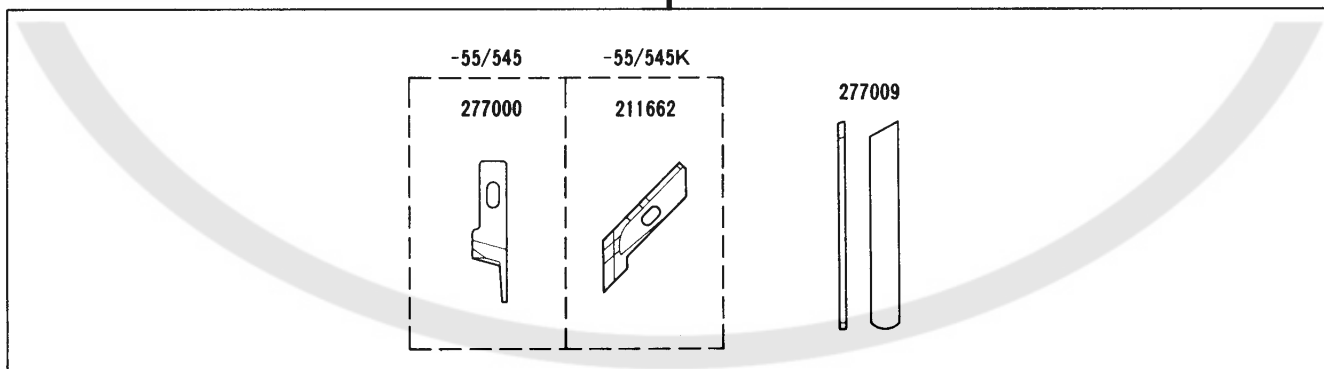
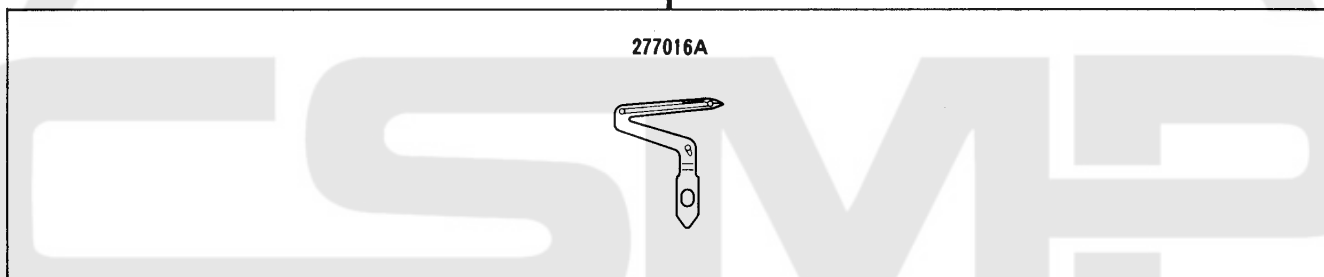
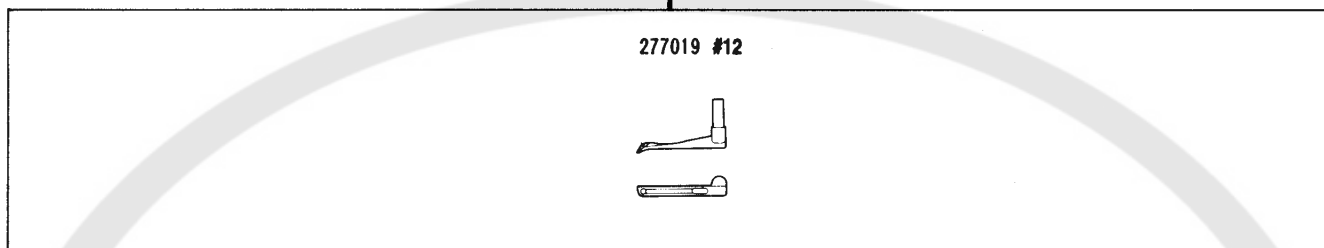
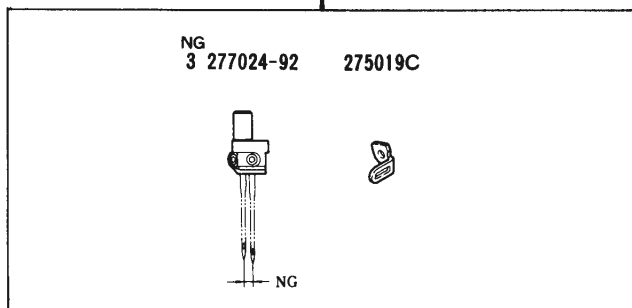
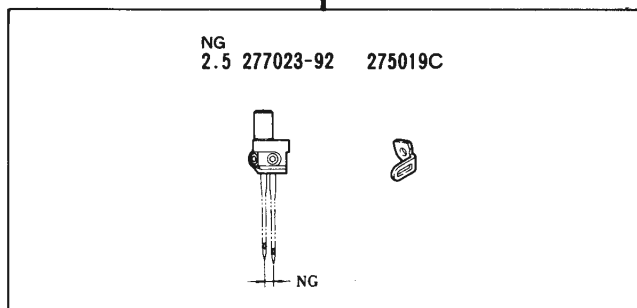

テープ付用(極厚生地)
ATTACHING TAPE
(EXTRA HEAVY FABRIC)

EXT5214-84/433(K)

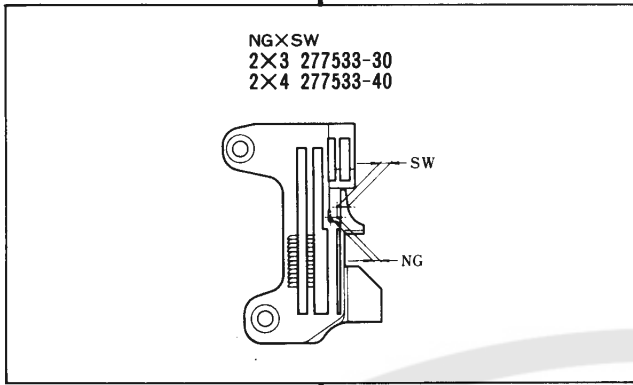

EXT5214-C3P1/333(K)
EXT5214-C3P2/333(K)

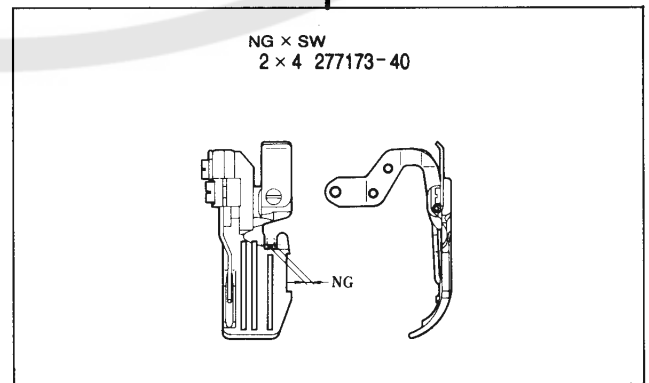
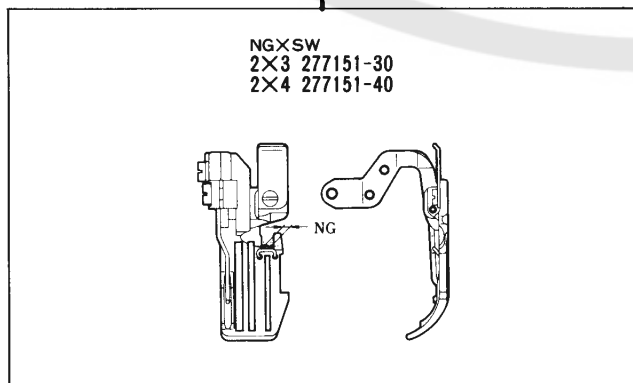
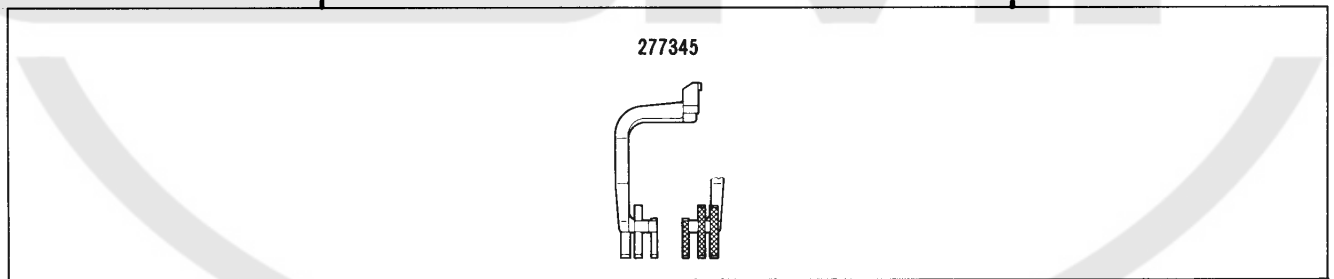
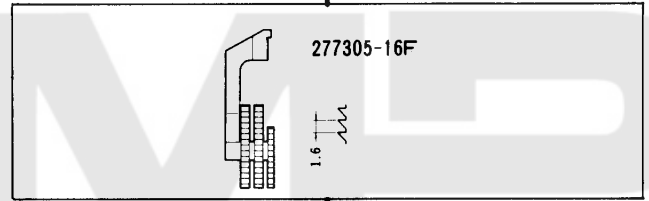
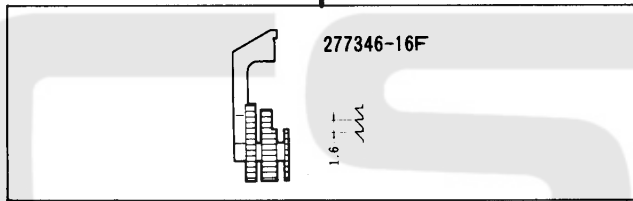
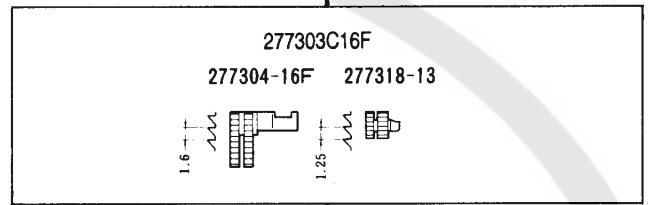
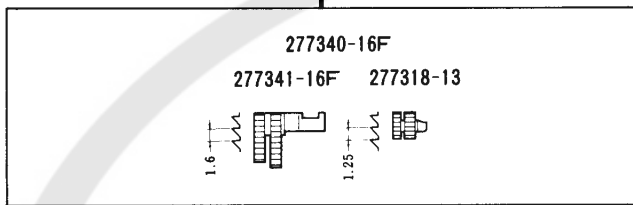
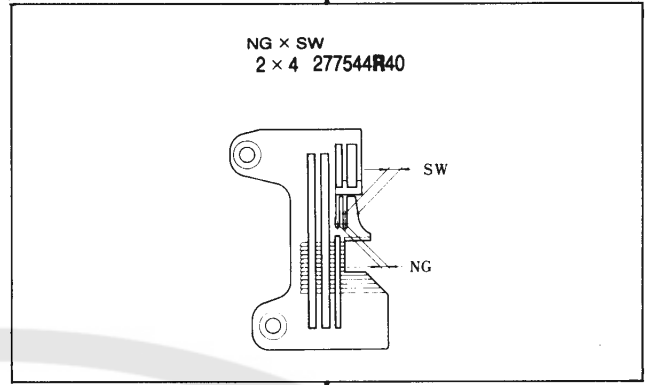

EXT5214-84/433(K)

EXT5214-C3P1/333(K)
EXT5214-C3P2/333(K)

NG
2 277022-92 275019B

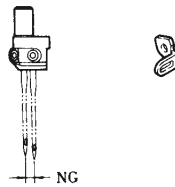

277011 #3

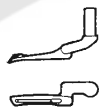

277010A #5

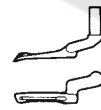

277015

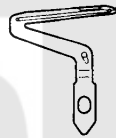

-84/433 -84/433K

201121A



210755

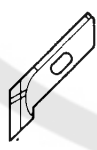

SW 3 201127 SW 4 202295



-C3P1/333 -C3P1/333K
-C3P2/333 -C3P2/333K

201121A



210755

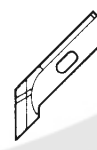

202295



277005A

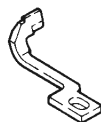

277004



バックタック用(厚生地)
BACKLATCHING
(HEAVY FABRIC)

パイピング用(中厚生地)
PIPING
(MEDIUM FABRIC)

EXT3200 Series
ゲージパーツ表(1)

EXT3200 Series
GAUGE PARTS LIST (1)

形式 MACHINE TYPE /SPEC.	ゲージ		針板 NEEDLE PLATE	主送り歯(組)		主送り歯本体 MAIN FEED DOG	補助送り歯 AUX. FEED DOG	差動送り歯 DIFF. FEED DOG	上送り歯 TOP FEED DOG	押エ(組) PRESSER FOOT ASS.	上ルーバー UPPER LOOPER	上スプレッダー UPPER SPREADER	下ルーバー LOWER LOOPER	二重繰ルーバー CHAINSTITCH LOOPER
	NG	SW		MAIN FEED DOG ASS.	MAIN FEED DOG									
(15) EXT3216-02/223(K)	3	3	277515R30	277323-16		(277324-16)	(277318-13)	277326-16	277320	277153-30 " -40 " -50	277010 #2	277014A #8	277015	277018
		4	277513R40											
		5	" 50											
(15) EXT3216-03/233(K)	3	4	277517R40	277327-16		(277328-16)	(277318-13)	277330-16	277320	277154-40 " -50 277155-50 " -60	277010A #5	277014B #9	277015	277018
		5	" 50											
		5	277518R50											
EXT3244-03/333(K)	3 × 2	4	277518R40	277327-16		(277328-16)	(277318-13)	277329-16	277320	277154A40 277155A40	277010A #5	—	277015	277018
		4	277519R40											
		4	277519R40											

形式 MACHINE TYPE /SPEC.	ゲージ		上メス		下メス LOWER KNIFE	オーバー針受		二重繰針受		針留 NEEDLE HOLDER	針留糸道 THREAD GUIDE (NDL HOLDER)	針 NEEDLE
	NG	SW	平メス UPPER KNIFE FLAT KNIFE	角メス ANGLED KNIFE		前 FRONT	後 REAR	前 FRONT	後 REAR			
(15) EXT3216-02/223(K)	3	3	201121A	210755	202295	277007	277004	277008	277006	277027-92	275030	DC × 27 # 11
		4										
		5										
(15) EXT3216-03/233(K)	3	4	201121A	210755	202295	277007	277004	277008	277006	277027-92 277028-92	275030	DC × 27 # 14
		5										
		5										
EXT3244-03/333(K)	3 × 2	4	201121A	210755	202295	277007	277004	277008	277006	277030-92 277031-92	275030	DC × 27 # 11
		4										

EXT3200 Series
ゲージパーツ表 (2)

EXT3200 Series
GAUGE PARTS LIST (2)

形式 MACHINE TYPE /SPEC.	ゲージ GAUGE		針板 NEEDLE PLATE	主送り歯(組) MAIN FEED DOG ASS.		主送り歯本体 MAIN FEED DOG	補助送り歯 AUX. FEED DOG	差動送り歯 DIFF. FEED DOG	上送り歯 TOP FEED DOG	押エ(組) PRESSER FOOT ASS.	上ルーバー UPPER LOOPER	上スプレッダー UPPER SPREADER	下ルーバー LOWER LOOPER	二重環ルーバー CHAINSTITCH LOOPER
	NG	SW		5	6									
(15) EXT3216-04/435K	5	5	277524T50	277337-25	(277338-25)	(277318-13)	277339-25	277343-20	277156-50	277011 #3	277014 #1	277015	277018-C	
		6	" 60						" -60					
(15) EXT3244-04/435K	5 × 3	4	277525T40	277337-25	(277338-25)	(277318-13)	277339-25	277343-20	277156A40	277011 #3		277015	277018-C	
		5	277524T50						277156-50					
		6	" 60	277337-25	(277338-25)	(277318-13)	277339-25	277343-20	" -60	277017 #11	277014A #8	277015A	277018-C	
(15) EXT3244H-05/535K	5 × 3	4	277525T40	277337-25	(277338-25)	(277318-13)	277339-25	277343-20	277156A40	277017 #11		277015A	277018-C	
		4	277517R40						277161-40					
		5	" 50	277327-16	(277328-16)	(277318-13)	277330-16	277320A	" -50	277010A #5	277014B #9	277015	277018	
(15) EXT3216-42/233(K)	5	5	277516R50				277329-16	277321A	277164-50					
		6	" 80						" -80					

形式 MACHINE TYPE /SPEC.	ゲージ GAUGE		上メス UPPER KNIFE		下メス LOWER KNIFE	オーバー針受 OVERLOCK NEEDLE GUARD		二重環針受 CHAINSTITCH NEEDLE GUARD		針留 NEEDLE HOLDER	針留糸道 THREAD GUIDE (NDL HOLDER)	針 NEEDLE
	NG	SW	平メス FLAT KNIFE	角メス ANGLED KNIFE		前 FRONT	後 REAR	前 FRONT	後 REAR			
	(15) EXT3216-04/435K	5	5		211662	277009	277007	277004	277008	277006	277029-92	275030A
		6									275030A	DC × 27 # 21
(15) EXT3244-04/435K	5 × 3	4		211662	277009	277007	277004	277008	277006	277029-92	275030A	DO × 5 # 21
		5										
		6										
(15) EXT3244H-05/535K	5 × 3	4		211662	277009	277007	277004	277008	277006	277029-92	275030A	DO × 5 # 21
		4										
		5	201121A							277027-92		
(15) EXT3216-42/233(K)	5	5		210755	202295	277007	277004	277008	277006	277028-92	275030	DC × 27 # 14
		6										

形式 MACHINE TYPE /SPEC.	ゲージ		針板 NEEDLE PLATE	主送り歯(組)		主送り歯本体 MAIN FEED DOG	補助送り歯 AUX. FEED DOG	差動送り歯 DIFF. FEED DOG	上送り歯 TOP FEED DOG	押工(組) PRESSER FOOT ASS.	上ルーバー UPPER LOOPER	上スプレッダー UPPER SPREADER	下ルーバー LOWER LOOPER	二重環ルーバー CHAINSTITCH LOOPER											
	NG	SW		MAIN FEED DOG ASS.	MAIN FEED DOG																				
(15) EXT3216-C3P1/ 233(K)	3	4	277545R40	277327A16	(277328-16)		(277318-13)	277330-16	277320B	277176-40	277010A #5	277014B #9	277015	277018											
		5	" 50																						
	5	5	277546R50																						
		6	" 60																						
	3	4	277545R40												277327A16	(277328-16)		(277318-13)	277330-16	277320B	277176-40	277010A #5	277014B #9	277015	277018
		5	" 50																						
5	5	277546R50																							
	6	" 60																							

形式 MACHINE TYPE /SPEC.	ゲージ		上メス		下メス LOWER KNIFE	オーバー針受		二重環針受		針留 NEEDLE HOLDER	針留米道 THREAD GUIDE (NDL HOLDER)	針 NEEDLE										
	NG	SW	平メス UPPER KNIFE FLAT KNIFE	角メス ANGLED KNIFE		前	後	前	後													
(15) EXT3216-C3P1/ 233(K)	3	4	201121A	210755	202295	277007	277004	277008	277006	277027-92	275030	DC X 27 # 14										
		5																				
	5	5																				
		6																				
	3	4											201121A	210755	202295	277007	277004	277008	277006	277027-92	275030	DC X 27 # 14
		5																				
5	5																					
	6																					

形式 MACHINE TYPE /SPEC.	ゲージ		針板 NEEDLE PLATE	主送り歯(組)		主送り歯本体 MAIN FEED DOG	補助送り歯 AUX. FEED DOG	差動送り歯 DIFF. FEED DOG	上送り歯 TOP FEED DOG	押工(組) PRESSER FOOT ASS.	上ルーバー	下ルーバー
	NG	SW		4	5						277010 #2	277015
EXT5204 - 02/ 233(K)	-	4	277504R40	277303 - 16F	(277304 - 16F)	(277318 - 13)	277305 - 16F	277344	277149 - 40	" 50	277010 #2	277015
		5	" 50									
EXT5214 - 03/ 333(K)	2	3	277505R30	277303 - 16F	(277304 - 16F)	(277318 - 13)	277305 - 16F	277344	277150 - 30	" 40	277010A #5	277015
		4	" 40									
		5	" 50									
EXT5214 - M03/ 333(K)	2	3	277505R30	277303 - 16F	(277304 - 16F)	(277318 - 13)	277305 - 16F	277344	277150 - 30	" 40	277010A #5	277034
		4	" 40									
		5	" 50									
EXT5204 - 12/ 223(K)	-	4	277500P40	277300 - 16F	(277301 - 16F)	(277318 - 13)	277302 - 16F	277358	277181 - 40	277010 #2	277015	

形式 MACHINE TYPE /SPEC.	ゲージ		上メス		下メス	針受		針留	針留糸道 THREAD GUIDE (NDL HOLDER)	針 NEEDLE
	NG	SW	平メス UPPER KNIFE FLAT KNIFE	角メス ANGLED KNIFE		前 NEEDLE GUARD FRONT	後 CHAINSTITCH REAR			
EXT5204 - 02/ 233(K)	-	4	201121A	210755	202295	277005	277004	179630 - 92	275019A	DC X 27 # 9
		5								
EXT5214 - 03/ 333(K)	2	3	201121A	210755	202295	277005	277004	277022 - 92	275019B	DC X 27 # 9
		4								
		5								
EXT5214 - M03/ 333(K)	2	3	201121A	210755	202295	277005	277004	277022 - 92	275019B	DC X 27 # 9
		4								
		5								
EXT5204 - 12/ 223(K)	-	4	201121A	210755	202295	277005	277004	179630 - 92	275019A	DC X 27 # 9

形式形式 MACHINE TYPE /SPEC.	ゲージ		針板 NEEDLE PLATE	主送り歯(組)		主送り歯本体 MAIN FEED DOG	補助送り歯 AUX. FEED DOG	差動送り歯 DIFF. FEED DOG	上送り歯 TOP FEED DOG	押エ(組) PRESSER FOOT ASS.	上ルーバー	下ルーバー
	NG	SW		MAIN FEED DOG ASS.	MAIN FEED DOG						UPPER LOOPER	LOWER LOOPER
EXT5214-43/333(K)	2	3	277505R30	277303-16F	(277304-16F)	(277318-13)	277305-16F	277345	277345	277151-30	277010A #5	277015
		4	" 40									
		5	" 50									
EXT5214-54S1/433(K) EXT5214-54S2/433(K)	2	3	277505R30	277303-16F	(277304-16F)	(277318-13)	277316-16F	277344	277344	277150A30	277011 #3	277015
		4	" 40									
		5	" 50									
EXT5214-54S1/443(K) EXT5214-54S2/443(K)	2	3	277507R30	277351-16F	(277352-16F)	(277318-13)	277353-16F	277345A	277345A	277151A30	277011 #3	277015
		4	" 40									
		5	" 50									
2.5	3.5	4.5	277508R35	277351-16F	(277352-16F)	(277318-13)	277353-16F	277345A	277345A	277152A35	277011 #3	277015
		4.5	" 45									

形式 MACHINE TYPE /SPEC.	ゲージ		上メス		下メス LOWER KNIFE	針受		針留 NEEDLE HOLDER	針留糸道 THREAD GUIDE (NDL HOLDER)	針 NEEDLE
	NG	SW	平メス UPPER KNIFE/LOWER FLAT KNIFE	角メス ANGLED KNIFE		前 NEEDLE GUARD/CHAINSTITCH FRONT	後 REAR			
EXT5214-43/333(K)	2	3	201121A	210755	202295	277005	277004	277022-92	275019B	DC X 27 # 11
		4	"	"	"	"	"	"	"	"
		5	"	"	"	"	"	"	"	"
EXT5214-54S1/433(K) EXT5214-54S2/433(K)	2	3	201121A	210755	202295	277005	277004	277022-92	275019B	DC X 27 # 11
		4	"	"	"	"	"	"	"	"
		5	"	"	"	"	"	"	"	"
EXT5214-54S1/443(K) EXT5214-54S2/443(K)	2	3	201121A	210755	202295	277005	277004	277022-92	275019B	DC X 27 # 11
		4	"	"	"	"	"	"	"	"
		5	"	"	"	"	"	"	"	"
2.5	3.5	4.5	201121A	210755	202295	277005	277004	277023-92	275019C	DC X 27 # 11
		4.5	"	"	"	"	"	"	"	"

形式 MACHINE TYPE /SPEC.	ゲージ		針板 NEEDLE PLATE	主送り歯(組) MAIN FEED DOG ASS.	主送り歯本体 MAIN FEED DOG	補助送り歯 AUX. FEED DOG	差動送り歯 DIFF. FEED DOG	上送り歯 TOP FEED DOG	押エ(組) PRESSER FOOT ASS.	上ルーバー	下ルーバー
	NG	SW								UPPER LOOPER	LOWER LOOPER
EXT5214H-55/545(K)	2.5	3.5	277526S35	277351-25F	(277352-25F)	(277318-13)	277353A25F	277345A20F	277152A35	277019 #12	277016A
		4.5	" 45								
	3	4	277510S40								
		5	" 50								
EXT5214-82/433(K)	2	3	277533-30	277340-16F	(277341-16F)	(277318-13)	277346-16F	277345	277151-30	277011 #3	277015
		4	" 40								
EXT5214-C3P1/ 333(K)	2	4	277544R40	277303C16F	(277304-16F)	(277318-13)	277305-16F	277345	277173-40	277010A #5	277015
EXT5214-C3P2/ 333(K)	2	4	277544R40	277303C16F	(277304-16F)	(277318-13)	277305-16F	277345	277173-40	277010A #5	277015

形式 MACHINE TYPE /SPEC.	ゲージ		上メス		下メス	針受		針留	針留糸道 THREAD GUIDE (NDL HOLDER)	針
	NG	SW	平メス UPPER KNIFE FLAT KNIFE	角メス ANGLED KNIFE		前 FRONT	後 REAR			
EXT5214H-55/545(K)	2.5	3.5	277000	211862	277009	277005	277004	277023-92	275019C	DO X 5 # 16
		4.5								
	3	4								
		5								
EXT5214-82/433(K)	2	3	201121A	210755	201127	277005A	277004	277022-92	275019B	DC X 27 # 11
		4	201121A	202295						
EXT5214-C3P1/ 333(K)	2	4	201121A	210755	202295	277005	277004	277022-92	275019B	DC X 27 # 9
EXT5214-C3P2/ 333(K)	2	4	201121A	210755	202295	277005	277004	277022-92	275019B	DC X 27 # 9

INDEX

PART NO.	PAGE	NO. REF.	PART NO.	PAGE	NO. REF.	PART NO.	PAGE	NO. REF.	PART NO.	PAGE	NO. REF.	PART NO.	PAGE	NO. REF.
DCX27 # 9	55		7009	27	24	205361	23	17	240042	7	22	275532-91	25	1
DCX27 # 9	57		7009	29	43	205835	23	27	240104	25	36	275533	25	2
DCX27 #11	52		7013	17	11	206431	17	18	240110	5	11	275534	25	20
DCX27 #11	56		7013	21	3	207358	3	26	240148	3	25	275535	25	22
DCX27 #11	57		7013	21	12	207358	5	30	240148	5	32	275536	25	25
DCX27 #14	52		7013	21	22	208235	3	16	240152	19	2	275537	25	24
DCX27 #14	53		7013	23	33	208235	5	12	240291	3	45	275539	25	13
DCX27 #14	54		7013	27	3	208235	5	13	240292	13	1	275542-91	25	38
DCX27 #21	53		7013	27	12	208958-B	21	23	240294	3	34	276500-92	5	1
DOX 5 #16	57		7013	27	22	209229-B	21	15	240296	7	3	276501-92	5	5
DOX 5 #21	53		7013	29	41	209229-B	27	15	240297	5	4	276502-92	5	7
403	29	25	7014	3	43	209229AB	21	16	240298	5	3	276503	7	6
404	29	27	7018	15	8	209229AB	27	16	240322	7	24	276504-91	5	14
405	29	31	7018	19	6	210201-SD	17	17	240328	17	14	276505	5	15
406	29	26	7019	7	8	210307	25	41	240332	7	18	276506	5	17
407	29	29	7019	29	37	210320	19	14	240351	5	31	276507	5	18
408	29	30	7020	23	12	210533	7	25	240368	3	23	276508	5	20
409	29	32	7020	25	3	210680	23	2	240371	19	12	276509	5	21
410	29	34	7020	29	13	210680	29	2	270067	9	3	276510	5	23
413	29	38	7020	31	12	210680	31	2	270068	9	1	276511-92	5	25
1196	25	15	7021	3	18	210681	23	3	270069-91	9	5	276512	5	29
1202	29	23	7021	17	19	210681	29	3	270071	9	13	276513-92	7	1
1202	31	18	7021	25	26	210681	31	3	270073-9S	9	14	276514	7	9
1206	23	25	7022	25	30	210682	23	7	270073A9S	9	15	276515	7	5
1234	25	11	7023	29	12	210682	29	7	270079	9	8	276516	7	7
2430	23	21	7024	5	6	210682	31	7	270081	9	10	276517	7	11
2905	23	22	7026	7	17	210683	23	9	271003A	13	3	276518	7	16
2906	23	11	7044	3	33	210683	25	9	271003B	5	9	276519	7	13
2906	29	11	7056	3	3	210683	29	9	271018A91	13	4	276520-92	3	14
2906	31	11	7056	3	36	210683	31	9	271019A	13	6	276521	3	17
3044	23	6	7059	7	14	210684	23	10	271020	13	5	276522	3	19
3044	29	6	7063	9	6	210684	25	10	272538A	7	23	276524	7	19
3044	31	6	7066	9	9	210684	29	10	272539A	7	26	276525	27	31
3153	21	19	7066	25	40	210684	31	10	273001A92	3	48	276526	3	7
3153	27	19	7077	7	12	210685	23	1	273002A92	3	49	276527	3	21
4012	29	28	7099	25	31	210685	29	1	274028	21	18	276528-91	3	30
4500	7	20	7143	9	11	210685	31	1	274034	21	24	276529	3	31
4501	15	2	7154	9	4	210686	29	16	274035	3	44	276530	3	32
4511	9	2	7164	25	35	210686	31	14	274036	3	46	276531	3	38
4514	5	2	7193	15	14	210687	29	17	274037	3	47	276532	3	40
4514	5	28	7206	3	9	210687	31	15	274041	15	13	276533	3	8
4521	7	4	7207	3	10	210689	23	19	274042-92	15	1	276534	3	1
4522	17	5	7207	3	20	210690	23	14	274043	15	3	276535	3	5
4531	15	11	7233	3	6	210691	23	13	274044	15	4	276536-92	3	11
4533	3	12	137142	23	23	210692	23	24	274045-91	15	5	276537-92	5	27
4533	3	50	167066	23	16	210755	52		274048-91	15	12	276538	3	13
4533	5	8	167066	29	19	210755	53		274051	21	4	276539	3	28
4533	5	16	167066	29	24	210755	54		274051	23	34	276540	3	27
4533	5	26	167066	31	17	210755	55		274051	27	23	277000	57	
4534	3	15	167066	31	19	210755	56		274052	27	4	277004	52	
4534	7	2	179160-05	3	2	210755	57		274052	27	30	277004	53	
4543	3	39	179160-05	3	35	210930	9	12	274052	29	42	277004	54	
4543	3	41	179201-15	7	21	210930	15	9	274053	21	13	277004	55	
4543	5	22	179320-05	3	24	210955	25	14	274053	27	13	277004	56	
4543	5	24	179630-92	55		211267	25	43	274054	15	7	277004	57	
4543	25	21	179765-15	25	37	211301	7	15	274055	15	6	277005	55	
4554	13	2	200098	9	7	211618	17	2	274056	27	18	277005	56	
4806	25	33	200555	7	27	211662	53		274057	29	49	277005	57	
4818	29	33	201022	7	10	211662	57		274507	19	1	277005A	57	
4908	29	35	201121A	52		211879	29	20	274508	17	8	277006	52	
5030	21	8	201121A	53		211880	29	21	274528	17	16	277006	53	
5030	23	38	201121A	54		211946	29	22	274532-91	17	13	277006	54	
5030	27	8	201121A	55		211949	29	36	274539	17	21	277007	52	
5030	27	27	201121A	56		212059-B	21	6	274546-91	17	1	277007	53	
5030	29	46	201121A	57		212059-B	23	36	274547	17	4	277007	54	
5053	23	8	201127	57		212059-B	27	6	274548-91	19	13	277008	52	
5053	29	8	201191	23	5	212059-B	27	25	274549	19	3	277008	53	
5053	31	8	201191	29	5	212059-B	29	44	274550	19	4	277008	54	
5057	23	18	201191	31	5	212152	19	7	274551A91	19	8	277009	53	
5060	17	3	201211C91	23	26	212287	29	15	274552A91	19	9	277009	57	
5077	25	17	201233A	31	21	212435	25	27	274556	19	10	277010	52	
5077	25	19	201252	23	39	212436	25	28	274559	19	5	277010	55	
5088	23	15	201252	25	4	212498	21	17	275016A	11	2	277010A	52	
5088	29	18	201252	29	14	212498	27	17	275019A	55		277010A	53	
5088	31	16	201252	31	13	212601	25	5	275019B	55		277010A	54	
5104	25	8	201629	5	19	212603	25	12	275019B	56		277010A	55	
5157	23	20	202176	3	22	212658	25	18	275019B	57		277010A	56	
5184	23	4	202295	52		212660	25	16	275019C	56		277010A	57	
5184	29	4	202295	53		212668	21	7	275019C	57		277011	53	
5184	31	4	202295	54		212668	23	37	275027A	11	4	277011	56	
5299	23	28	202295	55		212668	27	7	275030	52		277011	57	
5380	25	6	202295	56		212668	27	26	275030	54		277014	53	
7007	3	29	202295	57		212668	29	45	275044A	11	5	277014A	52	
7008	21	25	202433	25	32	212978-91	17	6	275050	11	6	277014A	53	
7008	25	23	202577	5	10	212981	17	7	275051	11	1	277014B	52	
7009	21	5	204185	17	12	213218A92	15	10	275052A	11	3	277014B	53	
7009	21	14	204185	19	11	213578	17	9	275510					

INDEX

PART NO.	PAGE	NO. REF.	PART NO.	PAGE	NO. REF.	PART NO.	PAGE	NO. REF.
277015	55		277304-16F	56		277533-40	57	
277015	56		277304-16F	57		277544R40	57	
277015	57		277305-16F	55		277545R40	54	
277015A	53		277305-16F	56		277545R50	54	
277016A	57		277305-16F	57		277546R50	54	
277017	53		277316-16F	56		277546R60	54	
277018	52		277318-13	52		303312A	23	29
277018	53		277318-13	53		303313	23	30
277018	54		277318-13	54		9A3002	17	20
277018-C	53		277318-13	55				
277019	57		277318-13	56				
277022-92	55		277318-13	57				
277022-92	56		277320	52				
277022-92	57		277320A	53				
277023-92	56		277320B	54				
277023-92	57		277321	52				
277024-92	57		277321A	53				
277027-92	52		277321B	54				
277027-92	53		277323-16	52				
277027-92	54		277324-16	52				
277028-92	52		277325-16	52				
277028-92	53		277326-16	52				
277028-92	54		277327-16	52				
277029-92	53		277327-16	53				
277030	53		277327A16	54				
277030-92	52		277328-16	52				
277030A	53		277328-16	53				
277031-92	52		277328-16	54				
277032-92	53		277329-16	52				
277034	55		277329-16	53				
277130	21	21	277329-16	54				
277136	21	2	277330-16	52				
277136	23	32	277330-16	53				
277136A	29	48	277330-16	54				
277137	27	2	277337-25	53				
277137	27	21	277338-25	53				
277137	27	29	277339-25	53				
277137	29	40	277340-16F	57				
277138	21	10	277341-16F	57				
277138	27	10	277343-20	53				
277139	21	11	277344	55				
277139	27	11	277344	56				
277149-40	55		277345	56				
277149-50	55		277345	57				
277150-30	55		277345A	56				
277150-40	55		277345A20F	57				
277150-50	55		277346-16F	57				
277150A30	56		277351-16F	56				
277150A40	56		277351-25F	57				
277150A50	56		277352-16F	56				
277151-30	56		277352-25F	57				
277151-30	57		277353-16F	56				
277151-40	56		277353A25F	57				
277151-40	57		277358	55				
277151-50	56		277500P40	55				
277151A30	56		277504R40	55				
277151A40	56		277504R50	55				
277151A50	56		277505R30	55				
277152A35	56		277505R30	56				
277152A35	57		277505R40	55				
277152A45	56		277505R40	56				
277152A45	57		277505R50	55				
277153-30	52		277505R50	56				
277153-40	52		277507R30	56				
277153-50	52		277507R40	56				
277154-40	52		277507R50	56				
277154-50	52		277508R35	56				
277154A40	52		277508R45	56				
277155-50	52		277510S40	57				
277155-60	52		277510S50	57				
277155A40	52		277513R40	52				
277156-50	53		277513R50	52				
277156-60	53		277515R30	52				
277156-70	53		277516R50	52				
277156A40	53		277516R50	53				
277161-40	53		277516R60	52				
277161-50	53		277516R60	53				
277164-50	53		277517R40	52				
277164-60	53		277517R40	53				
277173-40	57		277517R50	52				
277176-40	54		277517R50	53				
277177-50	54		277518R40	52				
277181-40	55		277519R40	52				
277300-16F	55		277524T50	53				
277301-16F	55		277524T60	53				
277302-16F	55		277524T70	53				
277303-16F	55		277525T40	53				
277303-16F	56		277526S35	57				
277303C16F	57		277526S45	57				
277304-16F	55		277533-30	57				





■ PEGASUS
SEWING MACHINE MFG.
CO., LTD.®

