

*Revolutionize Production through
worker creativity by pegasus!*

EX5100

Cylinder Bed Overedgers
シリンダーベッド型オーバーロックミシン

Parts Catalog



PEGASUS®

パーツカタログの見方

■このパーツカタログは、1996年1月製造中のEX5100シリーズのミシンを次の要領で編集しています。

■2~45頁には部品を機構別に収録し、左頁が部品の分解図、右頁がパーツリストになっています。

また、部品分解図に付されている番号は、パーツリストのREF. NO.(参照番号)を示しています。

■ゲージパーツ系列構成図・ゲージパーツ表(46~51頁)

これらの部品は、特定の形式にのみ使用されている部品で、系列構成図は46~49頁に、ゲージパーツ表は50~51頁に一括して記載しています。

■52頁以降には部品番号インデックスを記載し、部品番号だけで、その図解、名称などが容易に引き出せます。

■部品を御注文いただくときは、必ず部品番号だけを明示して下さい。

なお、このパーツカタログの記載事項は改良により、予告なく変更されることがありますので、あらかじめご了承ください。

INTRODUCTION

■ This parts catalog covers the EX5100 series machine manufactured January, 1996.

■ On pages 2~45, each mechanism is arranged on facing pages, the first page containing the illustrations and the second page containing the data of the individual parts.

The number given to each illustrations is the REF. NO. on the parts list.

■ Gauge parts construction charts / gauge parts list.

Gauge parts are used in some machine types and sewing gauges only. Pages 46~49 contain the gauge parts construction charts in order to know the illustrations and the combinations of the parts, and pages 50~51 contain the gauge parts lists to obtain the data at a glance.

■ A numeric index of the parts is attached to page 52 on and after. The illustration and/or description of the required part can be easily referred to by the part number.

■ Always give the part numbers when ordering parts.

The contents of this parts catalog are subject to change to without notice.

掲載機種 (Models)

EX5100 Series

EX5104-02/233N

EX5104-04/433

EX5104-04/433N

EX5104-52D/333

EX5105-12/223N

EX5114-03/333N

EX5114-04/433

EX5114-04/433N

EX5114-92M2/223N

EX51 □□-□□/□□-□□/2041

目次

頁

ベッド機構	2-3
カバー機構(1)~(2)	4-7
クランクシャフト機構	8-9
針振り機構	10-11
上ルーパー機構	12-13
下ルーパー機構	14-15
送り機構(1)~(2)	16-19
上下メス機構	20-21
押エ機構	22-23
給油機構(1)~(2)	24-27
糸調子機構	28-29
糸道,糸線り	30-31
H.R.装置	32-33
裾引き用アタッチメント・当定規	34-35
半沈床式据付付属品	36-37
糸立台	38-39
付属品	40-41
専用部品(1)~(2)	42-45
ゲージパーツ系列構成図	46-49
ゲージパーツ表	50-51
部品番号インデックス	52-53

TABLE OF CONTENTS

Page

MACHINE BED FRAME	2-3
COVER(1)~(2)	4-7
CRANKSHAFT DRIVE MECHANISM	8-9
NEEDLE DRIVE MECHANISM	10-11
UPPER LOOPER DRIVE MECHANISM	12-13
LOWER LOOPER DRIVE MECHANISM	14-15
FEED MECHANISM(1)~(2)	16-19
KNIFE DRIVE MECHANISM	20-21
PRESSER FOOT MECHANISM	22-23
LUBRICATION MECHANISM(1)~(2)	24-27
THREAD TENTION MECHANISM	28-29
THREAD GUIDE & THREAD TAKEUP	30-31
H.R. DEVICE	32-33
ATTACHMENT FOR BLINDSTITCH HEMMING • FABRIC EDGE GUIDE	34-35
PARTS FOR SEMI - SUBMERGED INSTALLATION	36-37
THREAD STAND	38-39
ACCESSORIES	40-41
SPECIFIC PARTS(1)~(2)	42-45
GAUGE PARTS CONSTRUCTION CHART	46-49
GAUGE PARTS LIST	50-51
PART NUMBER INDEX	52-53

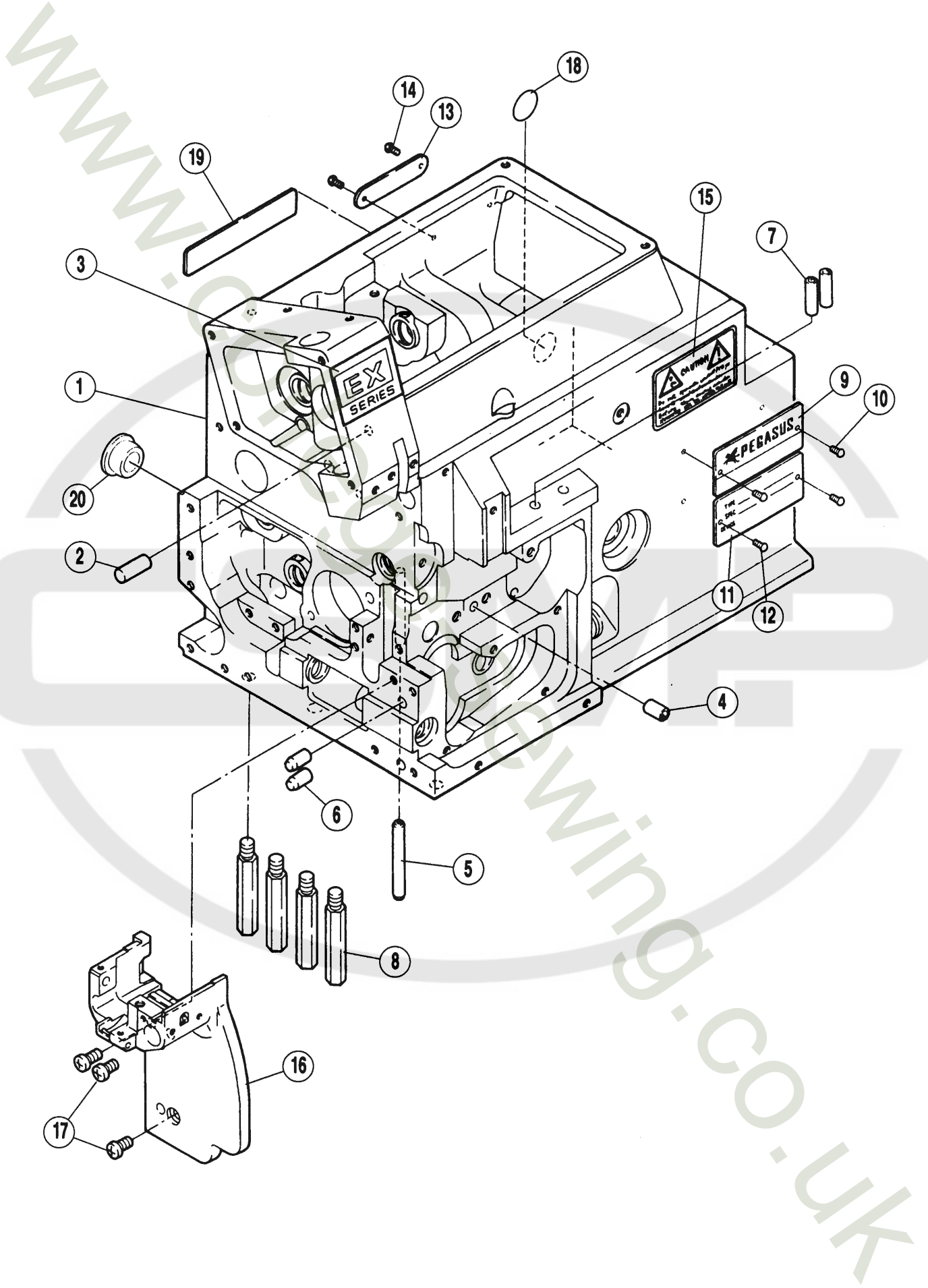

REF. NO.	PART NO. 部品番号	名称	NAME	QT.
01	270164-9S	ベッド (組)	MACHINE BED COMPLETE	1
02	201002	スプリングピン	PIN	1
03	270052	銘板	NAME PLATE	1
04	210182	スプリングピン	PIN	1
05	240299	スプリングピン	PIN	1
06	240094	ピン	PIN	2
07	240325	パイプ	PIPE	2
08	270047	足ピン	BED PIN	4
*09	270053	銘板	NAME PLATE	1
10	210679	止ピン	PIN	2
*11	250233	形式板	TYPE PLATE	1
12	210679	止ピン	PIN	2
13	230047A	機番板	SERIAL NUMBER PLATE	1
14	210679	止ピン	PIN	2
15	9A3048	シール	STICKER	1
*16	270154-SD	ブラケット	BRACKET ASSEMBLY	1
17	007019A	平ネジ / M4 × 8	SCREW	3
18	9A3071	シール	STICKER	1
*19	202526	記銘板	NAME PLATE	1
20	240310	栓	PLUG	1

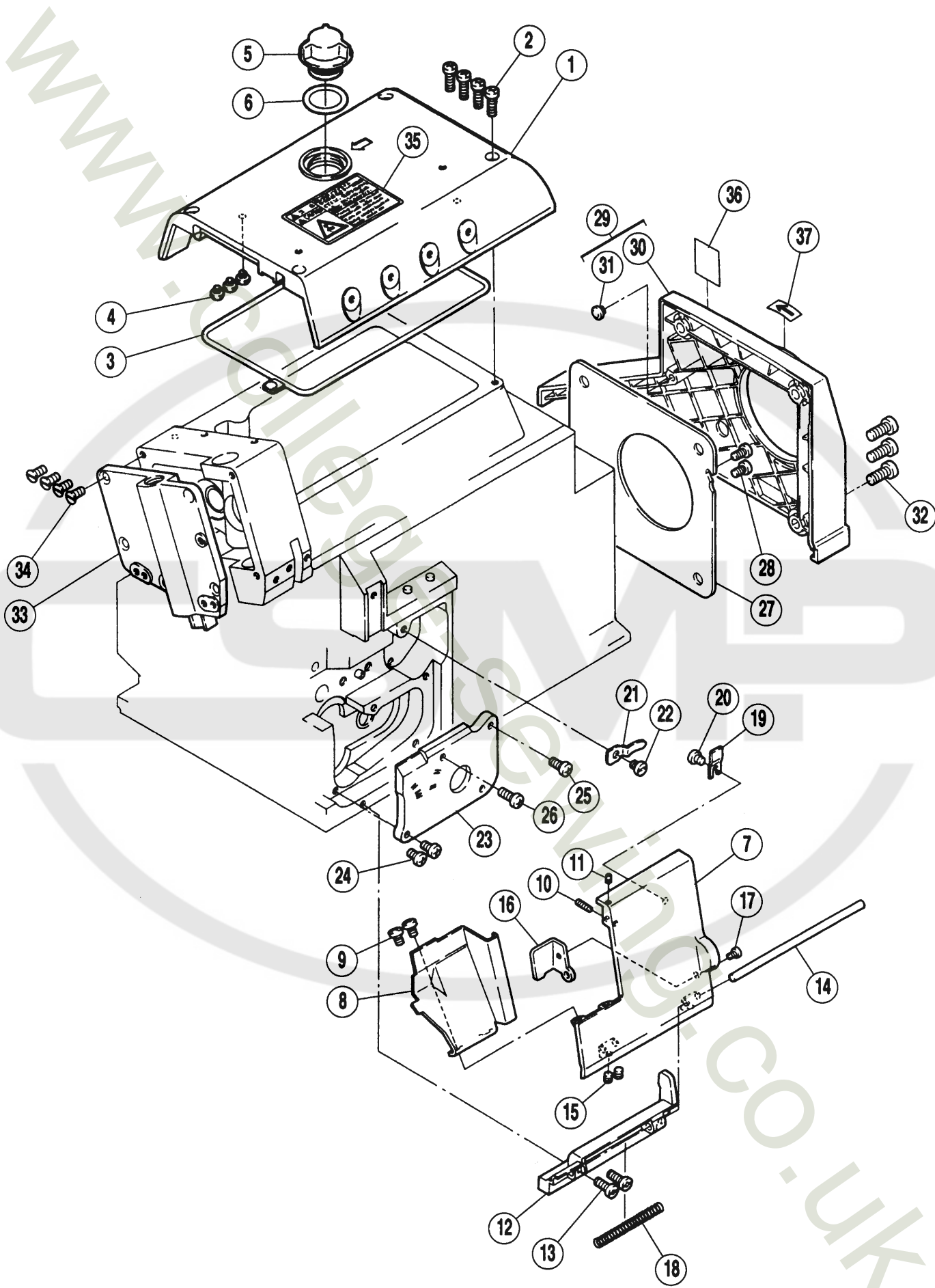

カバー機構 (1)

COVER (1)

REF. NO.	PART NO. 部品番号	名称	NAME	QT.
01	270148-SD	上カバー	TOP COVER	1
02	007022A	平ネジ	SCREW	4
03	270149	ガスケット	GASKET	1
04	240305	防振ゴム	CUSHION RUBBER	3
05	206457	オイル窓	OIL SIGHT WINDOW	1
06	206682	ガスケット	GASKET	1
07	270150-UD	前カバー (右)	FRONT COVER (RIGHT)	1
08	270151	前カバー (左)	FRONT COVER (LEFT)	1
09	007018A	平ネジ / M4 × 6	SCREW	2
10	004574	止ネジ / M3 × 12	SCREW	1
11	004535	止ネジ / M3 × 4	SCREW	1
12	270014A	ヒンジ	HINGE	1
13	007021A	平ネジ / M4 × 12	SCREW	2
14	240043A	平行ピン	PIN	1
15	004543	止ネジ / M4 × 4	SCREW	2
16	270018	ラッチ	LATCH	1
17	007009	平ネジ / M3 × 5	SCREW	1
18	240301	圧縮バネ	SPRING	1
19	270152	ラッチ	LATCH	1
20	007017A	平ネジ / M4 × 5	SCREW	1
21	210044	板バネ	FLAT SPRING	1
22	007017A	平ネジ / M4 × 5	SCREW	1
23	270153	カバー	COVER	1
24	007020A	平ネジ / M4 × 10	SCREW	2
25	007021A	平ネジ / M4 × 12	SCREW	1
26	007022A	平ネジ	SCREW	1
27	270025	ファンカバー	FAN COVER	1
28	007019A	平ネジ / M4 × 8	SCREW	2
29	270024-9U	ベルトカバー (組)	BELT COVER ASSEMBLY	1
30	270077-UB	ベルトカバー	BELT COVER	1
31	240305	防振ゴム	CUSHION RUBBER	1
32	007176	平ネジ / M6 × 14	SCREW	3
33	270010BUD	側面カバー	SIDE COVER	1
34	007044	皿ネジ / M4 × 10	SCREW	4
35	9A3067	シール	STICKER	1
36	9A3069	シール	STICKER	1
37	9A3072	シール	STICKER	1

WWW.COLEMAN.CO.UK

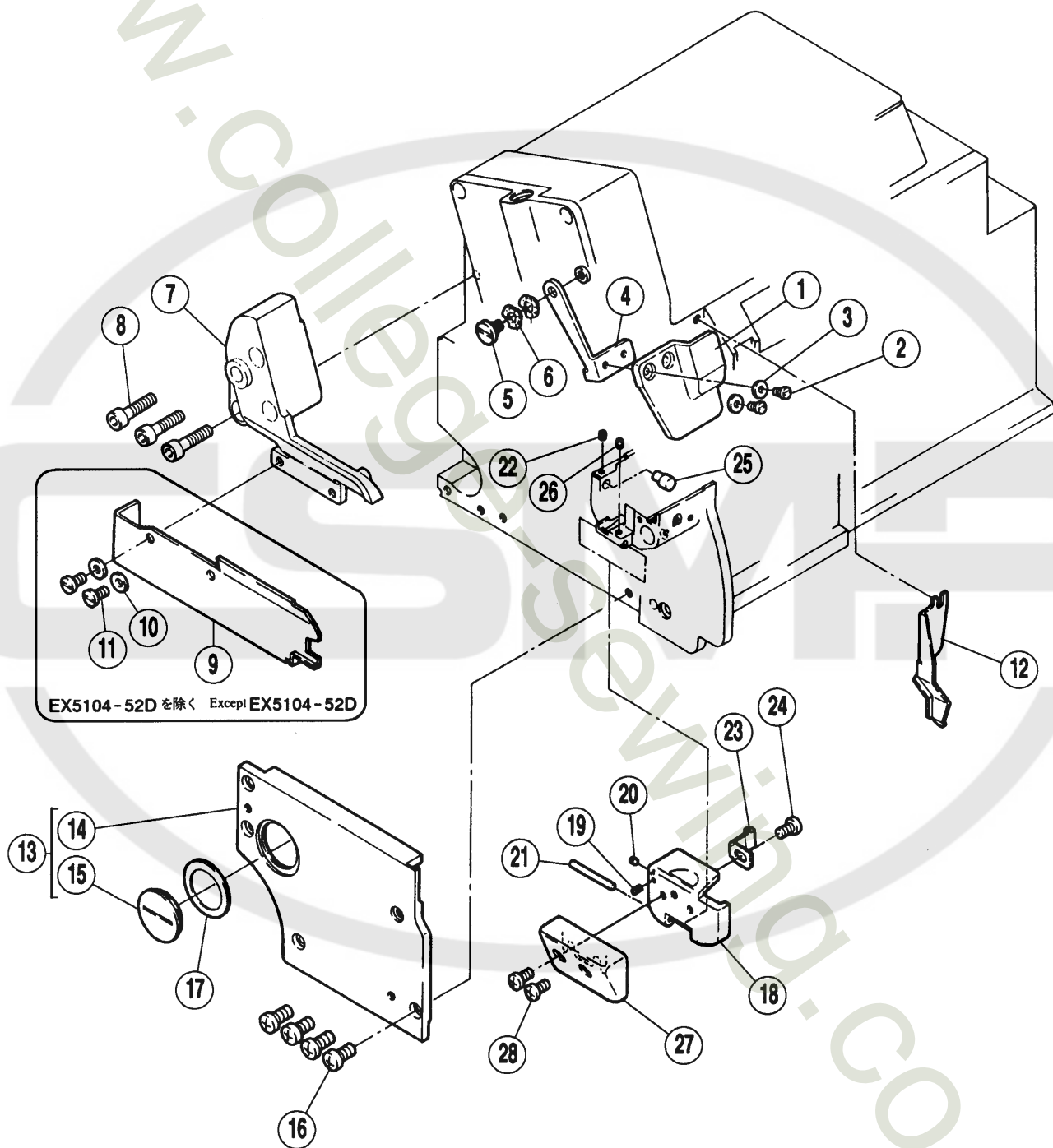

カバー機構 [2]

COVER [2]

REF. NO.	PART NO. 部品番号	名称	NAME	QT.
01	270032	アイガード	EYE GUARD	1
02	007062	平ネジ / M3 × 6	SCREW	2
03	202875	座金	WASHER	2
04	270034	ブラケット	BRACKET	1
05	007066	段付ネジ / M4	SCREW	1
06	210307	波板座金	WASHER	2
07	270068	ブラケット	BRACKET	1
08	004511	六角穴ボルト / M6 × 25	BOLT	3
09	270167	布案内	FABRIC GURAD	1
10	200098	座金	WASHER	2
11	007063	平ネジ / M4.5 × 8	SCREW	2
12	270179	カバー	COVER	1
13	270166-SD	横カバー (組)	SIDE COVER ASSEMBLY	1
14	270144	横カバー	SIDE COVER	1
15	270145	蓋	CAP	1
16	007019A	平ネジ / M4 × 8	SCREW	4
17	270175	ガスケット	GASKET	1
18	213062A	横蓋	CAP	1
19	004596	止ネジ / M3 × 6	SCREW	1
20	004554	止ネジ / M3 × 3	SCREW	1
21	306920	平行ピン	PIN	1
22	004554	止ネジ / M3 × 3	SCREW	1
23	213063	板バネ	FLAT SPRING	1
24	007196	平ネジ / M4 × 4	SCREW	1
25	213273	ラッチ	LATCH	1
26	004554	止ネジ / M3 × 3	SCREW	1
27	213094-91	カバー	COVER	1
28	007017A	平ネジ / M4 × 5	SCREW	2

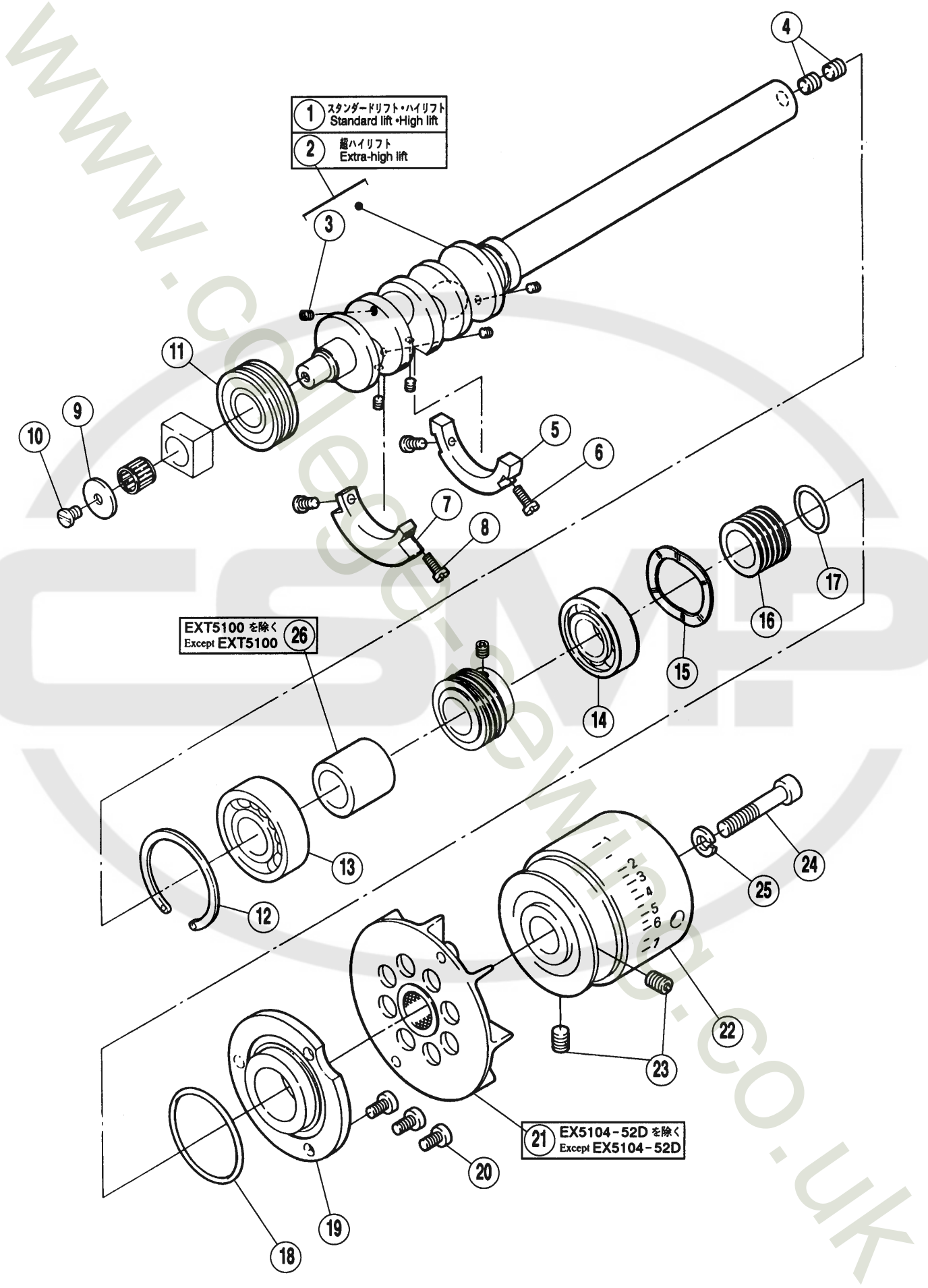

- ① スタンダードリフト・ハイリフト
Standard lift + High lift
- ② 超ハイリフト
Extra-high lift

EXT5100 を除く
Except EXT5100 ②6

EX5104-52D を除く
Except EX5104-52D ②1

REF. NO.	PART NO. 部品番号	名称	NAME	QT.
01	270522A	クランク軸	CRANKSHAFT	1
02	270522B	クランク軸	CRANKSHAFT	1
03	007151	止ネジ	SCREW	5
04	004522	止ネジ / M6 × 6	SCREW	2
05	270502	バランスウエイト	BALANCE WEIGHT	1
06	007011	平ネジ / M3 × 8	SCREW	2
07	270524	バランスウエイト	BALANCE WEIGHT	1
08	007011	平ネジ / M3 × 8	SCREW	2
09	240503	座金	WASHER	1
10	007143	平ネジ / M4 × 5.5	SCREW	1
11	240330	ボールベアリング	BALL BEARING	1
12	240335	止メ輪	RING	1
13	212987	ボールベアリング	BALL BEARING	1
14	211526	ボールベアリング	BALL BEARING	1
15	240306	波板座金	WASHER	1
16	210056	油切り	OIL SEAL	1
17	210057	Oリング	O RING	1
18	240340	Oリング	O RING	1
19	211528	ハウジング	BALL BEARING RETAINER	1
20	007020A	平ネジ / M4 × 10	SCREW	3
21	270505	ファン (組)	FAN COMPLETE	1
22	270504-UD	プーリー	MACHINE PULLEY	1
23	004541	止ネジ / M6 × 8	SCREW	2
24	004523	六角穴ボルト / M6 × 35	BOLT	1
25	204293	バネ座金	SPRING WASHER	1
26	270523	スペーサー	SPACER	1

WWW.COM

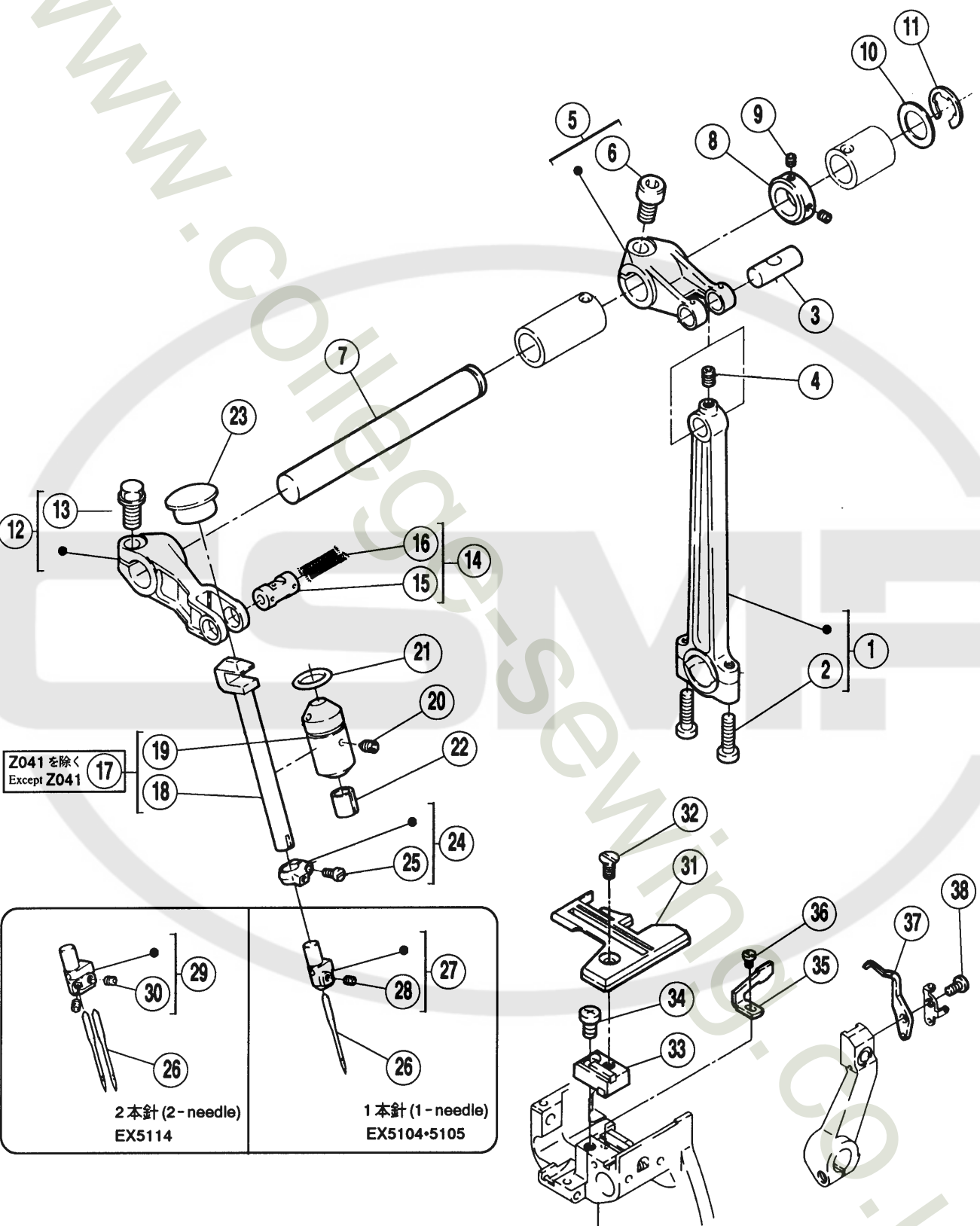

針振り機構

NEEDLE DRIVE MECHANISM

REF. NO.	PART NO. 部品番号	名称	NAME	QT.
01	271000-92	ロッド	CONNECTION	1
02	007023A	平ネジ / M4 × 16	SCREW	2
03	271001	ピン	PIN	1
04	004538	止ネジ / M4 × 6	SCREW	1
05	271002-92	クランク	CRANK	1
06	004533	六角穴ボルト	BOLT	1
07	271003D	軸	SHAFT	1
08	240292	カラー	COLLAR	1
09	004554	止ネジ / M3 × 3	SCREW	2
10	208235	座金	WASHER	1
11	202577	止メ輪	RING	1
12	271004-92	レバー	LEVER	1
13	007150	六角ボルト / M6 × 12	BOLT	1
14	271022A91	軸 (組)	SHAFT ASSEMBLY	1
15	271008A	軸	SHAFT	1
16	202177	給油紐	OIL WICK	2
17	271005-91T	ブッシュ (組) / 針棒	BUSHING ASSEMBLY	1
18	271006-T	針棒	NEEDLE BAR	1
19	271007	ブッシュ	BUSHING	1
20	004546	止ネジ / M4 × 5	SCREW	1
21	201022	リング	O RING	1
22	179009-05	フェルト	OIL FELT	1
23	240310	栓	PLUG	1
24	271009-92	リング	RING	1
25	007035	平ネジ / M3 × 6	SCREW	1
26	XXXXXX	針	NEEDLE	1
27	XXXXXX	針留	NEEDLE HOLDER	1
28	004554	止ネジ / M3 × 3	SCREW	1
29	XXXXXX	針留	NEEDLE HOLDER	1
30	004554	止ネジ / M3 × 3	SCREW	2
31	XXXXXX	針板	NEEDLE PLATE	1
32	007170	皿ネジ / M4 × 7.5	SCREW	1
33	213060A91	ブラケット (組)	BLACKET ASSEMBLY	1
34	007019A	平ネジ / M4 × 8	SCREW	1
35	XXXXXX	針受 (前)	NEEDLE GUARD (FRONT)	1
36	007031	平ネジ / M2.5 × 6	SCREW	1
37	XXXXXX	針受 (後)	NEEDLE GUARD (REAR)	1
38	007062	平ネジ / M3 × 6	SCREW	1

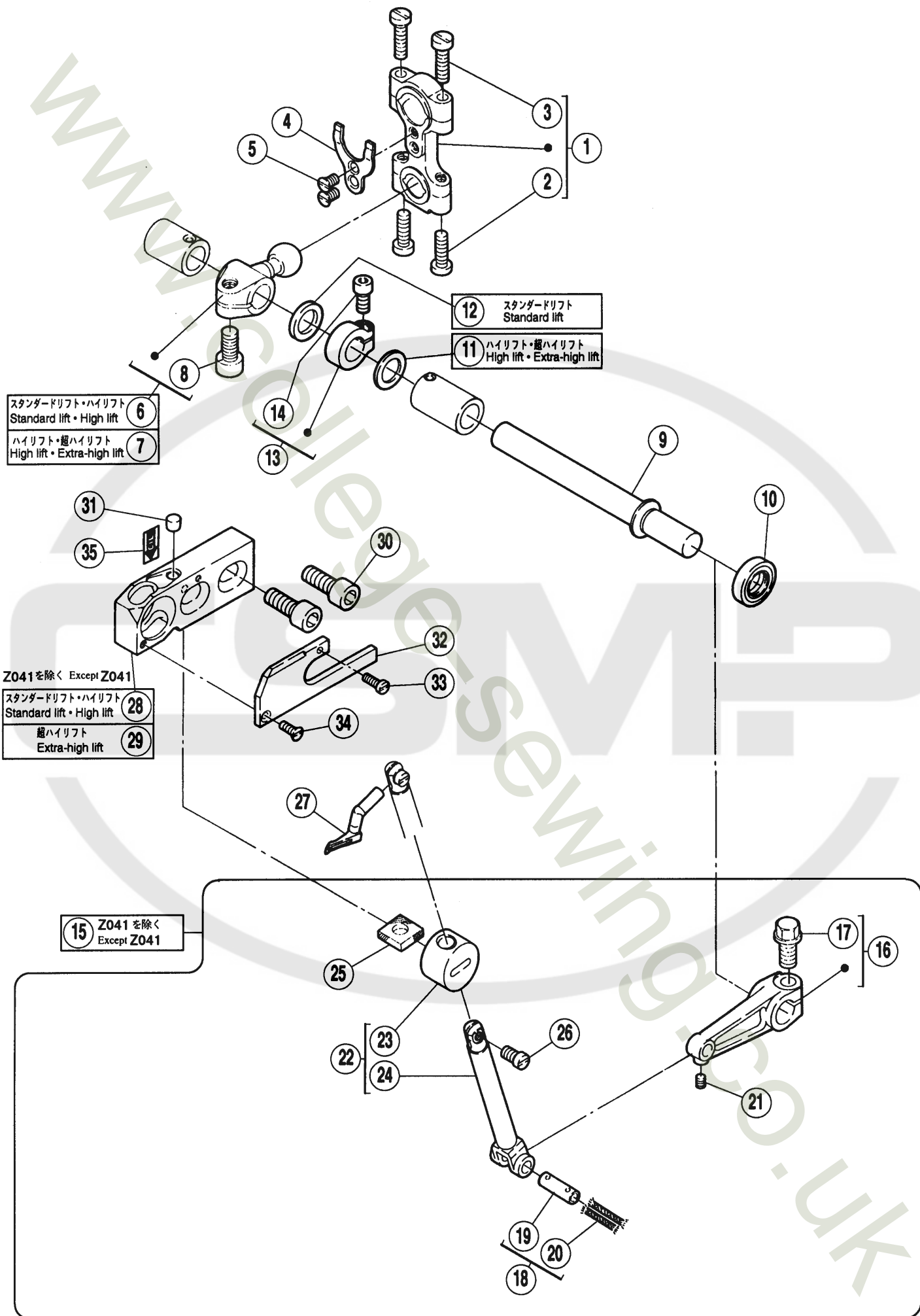

REF. NO.	PART NO. 部品番号	名称	NAME	QT.
01	271500-92	ロッド	CONNECTION	1
02	007022A	平ネジ / M4 × 14	SCREW	2
03	007023A	平ネジ / M4 × 16	SCREW	2
04	271501	振レ止	GUIDE	1
05	007041	皿ネジ / M3 × 6	SCREW	2
06	271502-92	クランク	CRANK	1
07	271503-92	クランク	CRANK	1
08	004533	六角穴ボルト	BOLT	1
09	271535	軸	SHAFT	1
10	210586A	オイルシール	OIL SEAL	1
11	240102	座金	WASHER	1
12	240312	座金	WASHER	1
13	240201-92	カラー	COLLAR	1
14	007110	六角穴ボルト / M4 × 9	BOLT	1
*15	271538-91	上ルーパー台セット	UPPER LOOPER HOLDER ASSEMBLY	1
16	271505-92	レバー	LEVER	1
17	007150	六角ボルト / M6 × 12	BOLT	1
18	179136-01	平行ピン (組)	PIN ASSEMBLY	1
19	179137-05	平行ピン	PIN	1
20	202176	給油紐	OIL WICK	2
21	004545	止ネジ / M3 × 4	SCREW	1
*22	271533-91	上ルーパー台 (組)	UPPER LOOPER HOLDER ASSEMBLY	1
*23	179129-05	上ルーパー台案内	GUIDE/UPPER LOOPER HOLDER	1
*24	271516	上ルーパー台	UPPER LOOPER HOLDER	1
25	179130-05	フェルト	OIL FELT	1
26	007054	平ネジ / M3.5 × 6.7	SCREW	1
27	XXXXXX	上ルーパー	UPPER LOOPER	1
28	271510D	上ルーパー土台	BASE/UPPER LOOPER HOLDER	1
29	271510E	上ルーパー土台	BASE/UPPER LOOPER HOLDER	1
30	004510	六角穴ボルト / M6 × 16	BOLT	2
31	271519	フィルター	FILTER	1
32	271534	カバー	COVER	1
33	007033	平ネジ / M2.5 × 8	SCREW	1
34	007039	皿ネジ / M2.5 × 6	SCREW	1
35	008421	オイルマーク	OIL MARK	1

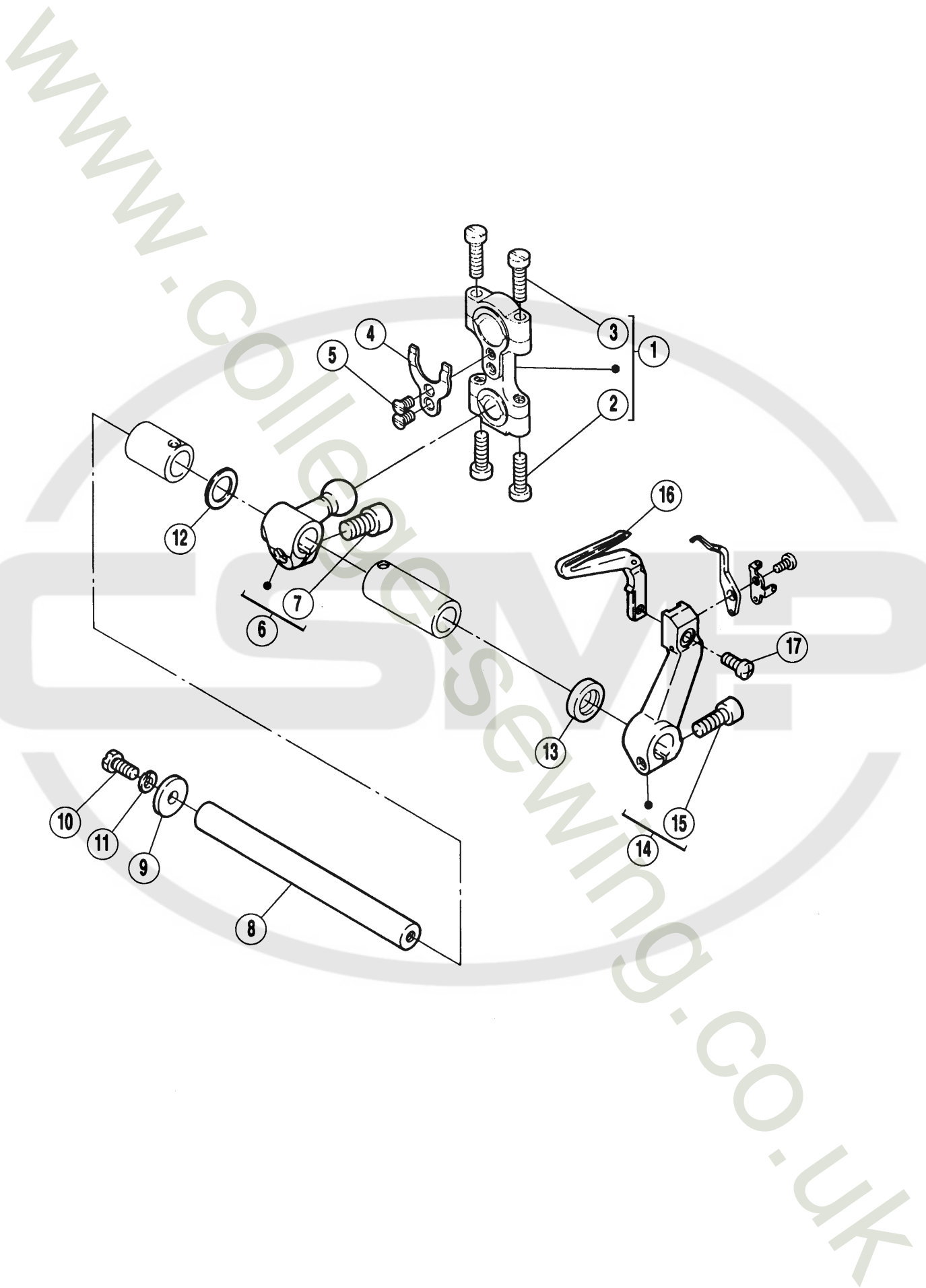

REF. NO.	PART NO. 部品番号	名称	NAME	QT.
01	271500-92	ロッド	CONNECTION	1
02	007022A	平ネジ / M4 × 14	SCREW	2
03	007023A	平ネジ / M4 × 16	SCREW	2
04	271501	振レ止	GUIDE	1
05	007041	皿ネジ	SCREW	2
06	272010-92	クランク	CRANK	1
07	004533	六角穴ボルト / M6 × 12	BOLT	1
08	271504B	軸	SHAFT	1
09	240338	座金	WASHER	1
10	007174	六角ネジ / M4 × 10	SCREW	1
11	303067	バネ座金	SPRING WASHER	1
12	240311	座金	WASHER	1
13	204052A	オイルシール	OIL SEAL	1
14	272011-91	下ルーパー台 (組)	LOWER LOOPER HOLDER ASSEMBLY	1
15	004501	六角穴ボルト / M5 × 14	BOLT	1
16	XXXXXX	下ルーパー	LOWER LOOPER	1
17	007013A	平ネジ	SCREW	1

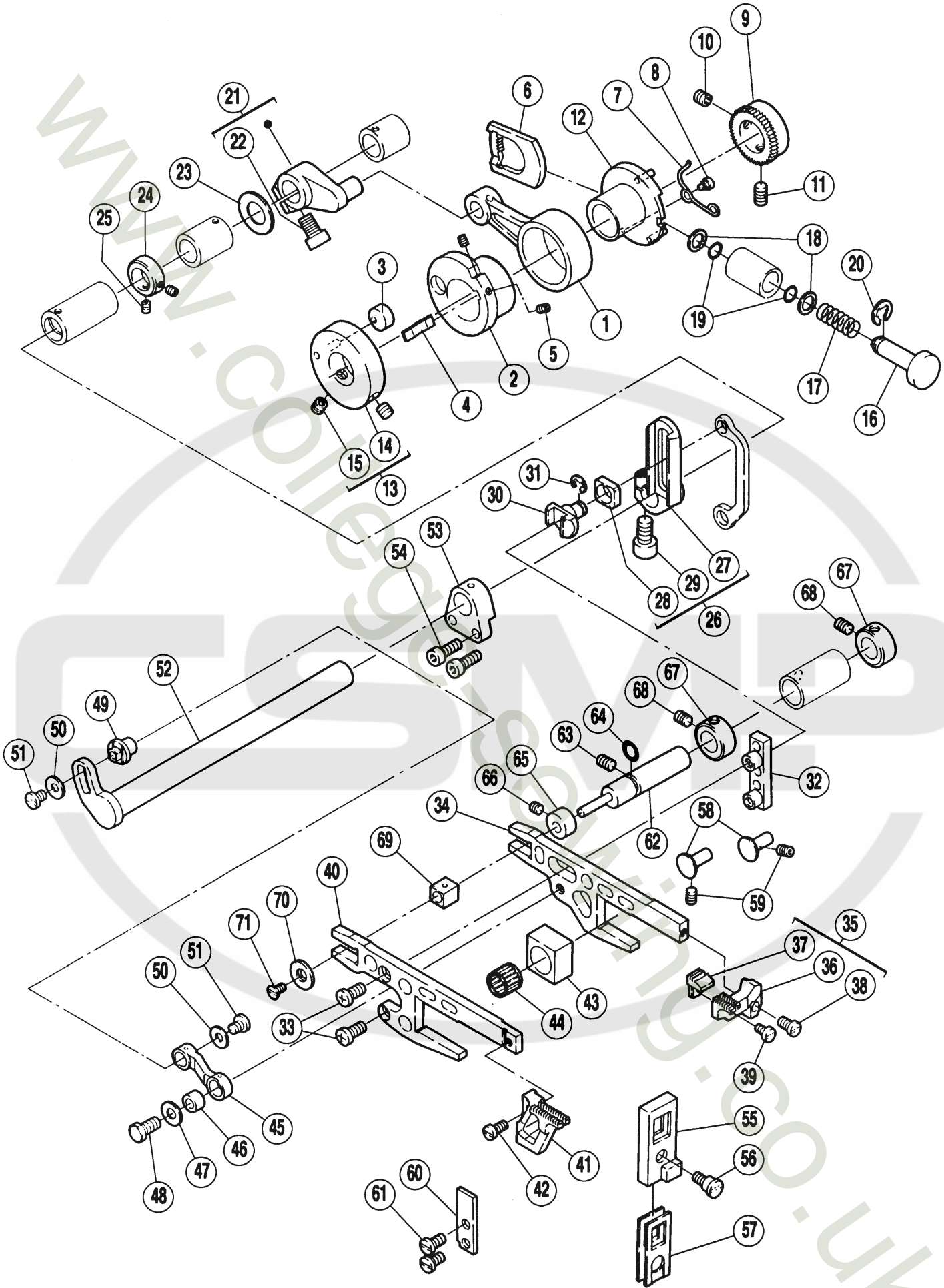

REF. NO.	PART NO. 部品番号	名称	NAME	QT.
01	272602	ロッキン	CONNECTION	1
02	272596	ドセ	ECCENTRIC	1
03	210129	送リ	GUIDE/FEED ECCENTRIC	1
04	210130A	エキセン	FLAT SPRING	1
05	004535	止	SCREW	1
06	272599	ラチ	RACHET	1
07	272613	チ	SPRING	1
08	007038	付	SCREW	1
09	272600	ネ	RATCHET	1
10	004514	止	SCREW	1
11	004572	止	SCREW	1
12	272597-91	調節	ECCENTRIC	1
13	272595-91	調節	REGULATOR	1
*14	272594	調節	BASE/REGULATOR	1
15	004514	止	SCREW	2
16	272610	プ	PUSH BUTTON	1
17	240517	縮	SPRING	1
18	240484	バネ	WASHER	2
19	200020	金	O RING	2
20	202522	座	RING	1
21	272603-92	ク	CRANK	1
22	004533	ラ	BOLT	1
23	208235	角	WASHER	1
24	240292	穴	COLLAR	1
25	004554	止	SCREW	2
26	272581-91	ク	CRANK ASSEMBLY	1
*27	272615	ラ	CRANK	1
28	272582	角	BLOCK	1
29	004533	穴	BOLT	1
30	272583	止	SLIDER	1
31	201629	メ	RING	1
32	272584	内	GUIDE	1
33	007020A	送	SCREW	2
34	272580	平	MAIN FEED BAR	1
35	XXXXXX	主	MAIN FEED DOG COMPLETE	1
36	XXXXXX	主	MAIN FEED DOG	1
37	XXXXXX	送	AUXILIARY FEED DOG	1
38	007010	助	SCREW	1
39	007013	ネ	SCREW	1
40	272585	差	DIFFERENTIAL FEED DOG BAR	1
41	XXXXXX	差	DIFFERENTIAL FEED DOG	1
42	007013	動	SCREW	1
43	272605	駒	BLOCK	1
44	240454-1	ニ	NEEDLE BEARING	1
44	240454-2	ニ	NEEDLE BEARING	1
44	240454-3	ニ	NEEDLE BEARING	1
45	272579	リ	LINK	1
46	272609	ン	BUSHING	1
47	240504	座	WASHER	1
48	007291	六	SCREW	1
49	272604	段	PIN	1
50	240505	付	WASHER	2
51	007143	金	SCREW	2
52	272578	平	CRANK SHAFT	1
53	272607	ク	BLOCK	1
54	004528	六	BOLT	2
55	272611	角	GUIDE/OIL SEAL	1
56	007292	内	SCREW	1
57	272612	切	OIL SEAL	2
58	272592	油	GUIDE/FEED BAR	2
59	004538	案	SCREW	2
60	272593	内	GUIDE/FEED BAR	1
61	007082	送	SCREW	2
62	272587	リ	PIN	1
63	004538	止	SCREW	1
64	204185	オ	O RING	1
65	240303	力	COLLAR	1
66	004543	止	SCREW	1
67	240404	力	COLLAR	2
68	004538	止	SCREW	2
69	272526	角	BLOCK	1
70	240055	座	WASHER	1
71	007041	皿	SCREW	1

●* = 販売不可
 ●XXXXXXはゲージパーツです。
 46-51頁のゲージパーツ表で確認してください。

●* = Not for sale basically
 ●XXXXXX is one of the gauge parts.
 Please confirm the correct part by the gauge parts lists on pages 46-51.

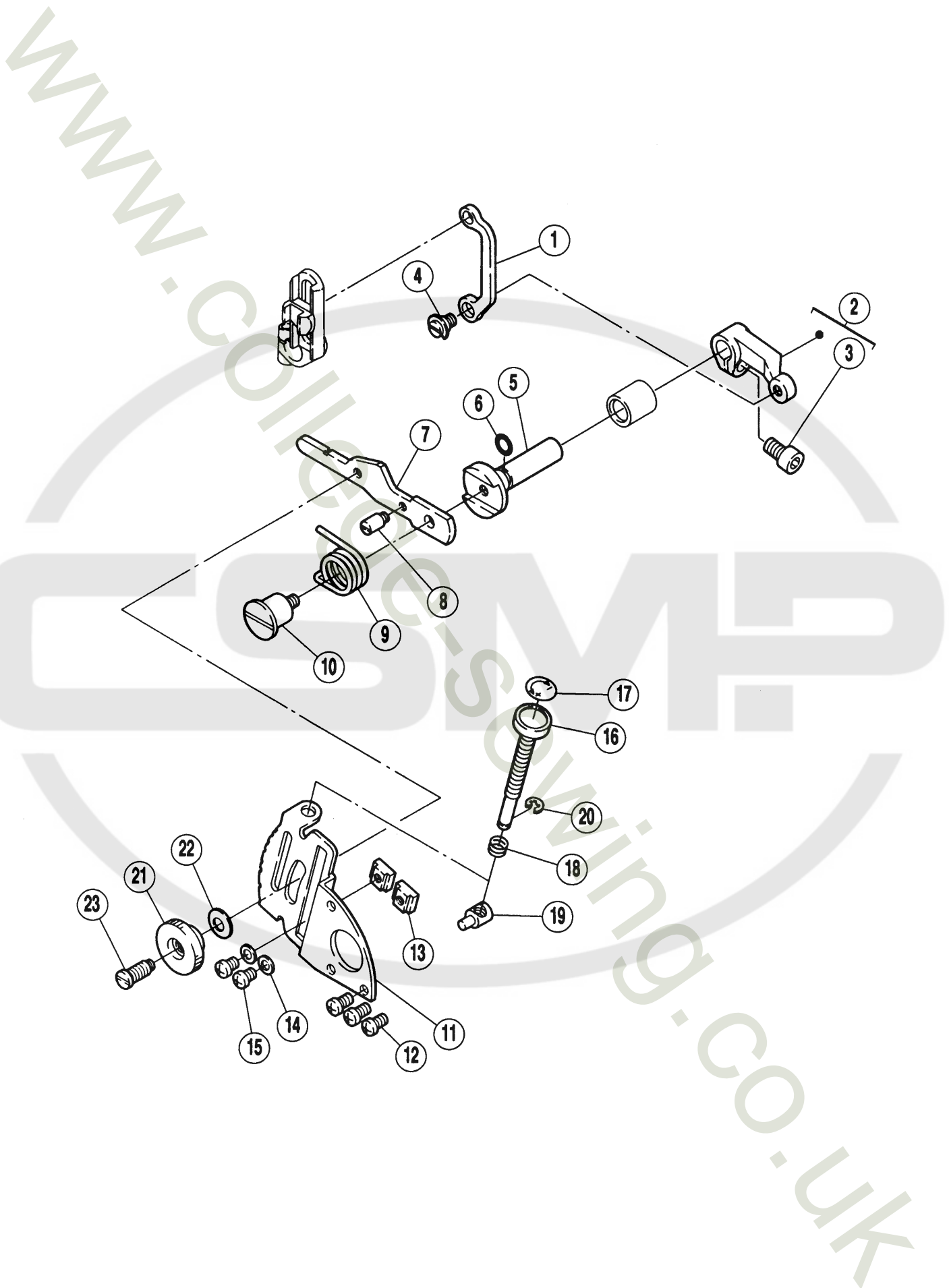

REF. NO.	PART NO. 部品番号	名称	NAME	QT.
01	272588	リンク	LINK	1
02	272589-92	レバー	LEVER	1
03	004533	六角穴ボルト / M6 × 12	BOLT	1
04	007058	段付ネジ / M5	SCREW	1
05	272590	軸	SHAFT	1
06	204185	Oリング	O RING	1
07	272591	レバー	LEVER	1
08	007139	ピン付ネジ / M4	SCREW	1
09	272614	ネジリバネ	SPRING	1
10	007161	段付ネジ / M5	SCREW	1
11	272586	調節板	REGULATOR PLATE	1
12	007019A	平ネジ / M4 × 8	SCREW	3
13	252658	ストッパー	STOPPER	2
14	303448	座金	WASHER	2
15	007018A	平ネジ / M4 × 6	SCREW	1
16	272538A	調節棒	ADJUSTING BAR	1
17	240332	シール	STICKER	1
18	210533	圧縮バネ	SPRING	1
19	272539A	段付ピン	PIN	1
20	200555	止メ輪	RING	1
21	252069	ナット	NUT	1
22	211301	バネ座金	SPRING WASHER	1
23	007059	段付ネジ / M4.5	SCREW	1

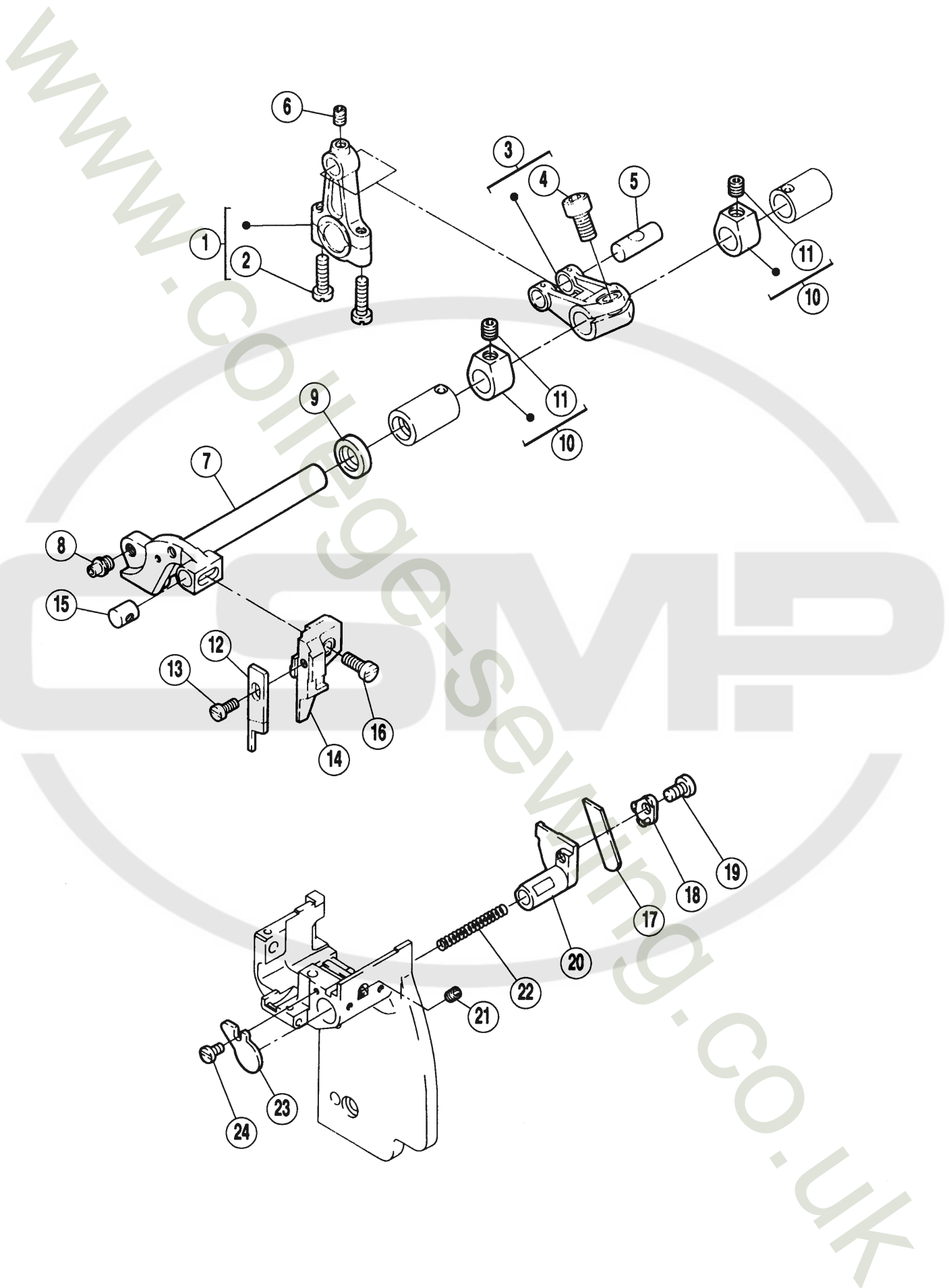

REF. NO.	PART NO. 部品番号	名称	NAME	QT.
01	273000-92	ロッド	CONNECTION	1
02	007023A	平ネジ / M4 × 16	SCREW	2
03	273001-92	クランク	CRANK	1
04	004533	六角穴ボルト / M6 × 12	BOLT	1
05	271001	ピン	PIN	1
06	004538	止ネジ / M4 × 6	SCREW	1
07	273004A	上メス台軸	UPPER KNIFE LEVER	1
08	308036	ピン付ネジ	SCREW	1
09	204052A	オイルシール	OIL SEAL	1
10	240235-92	カラー	COLLAR	2
11	004547	止ネジ / M6 × 5	SCREW	2
12	XXXXXX	上メス	UPPER KNIFE	1
13	007013	平ネジ / M3.5 × 8	SCREW	1
14	179712-05	上メス抱キ	UPPER KNIFE CLAMP	1
15	273006	案内ピン	PIN	1
16	007021	平ネジ / M4 × 12	SCREW	1
17	XXXXXX	下メス	LOWER KNIFE	1
18	213264-91	下メス押エ	CLAMP/LOWER KNIFE	1
19	007019	平ネジ / M4 × 8	SCREW	1
20	273027	下メス台軸	LOWER KNIFE HOLDER	1
21	004543	止ネジ / M4 × 4	SCREW	1
22	240518	圧縮バネ	SPRING	1
23	213084	蓋	CAP	1
24	007010	平ネジ / M3 × 6	SCREW	1

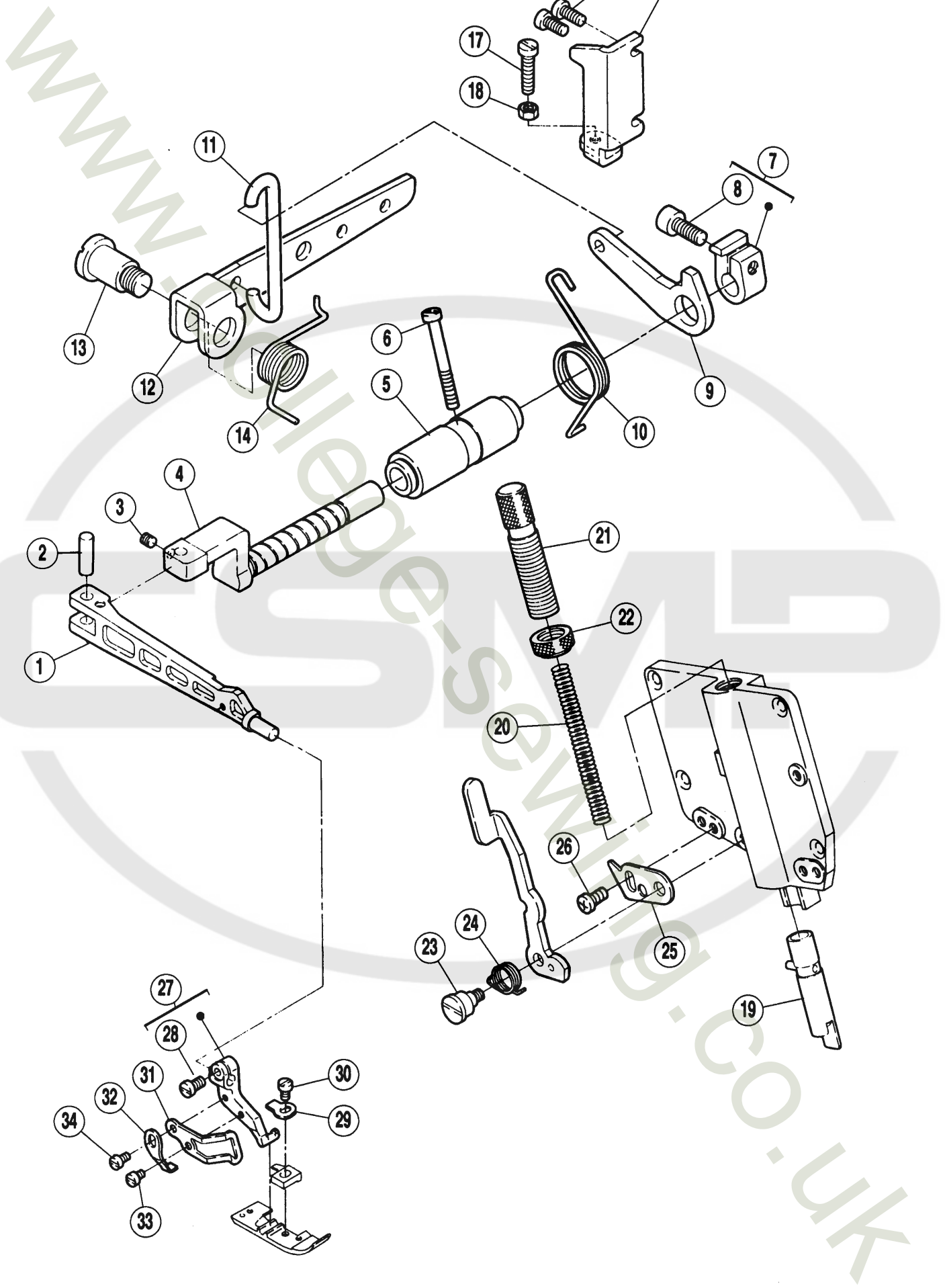

REF. NO.	PART NO. 部品番号	名称	NAME	QT.
01	274000-B	押エ台	PRESSER ARM	1
02	208549	平行ピン	PIN	1
03	004594	止ネジ / M4 × 4	SCREW	1
04	274001	軸 / 押エ台	SHAFT	1
05	274002	ブッシュ	BUSHING	1
06	007105	平ネジ / M4 × 40	SCREW	1
07	274003-92	カラー	COLLAR	1
08	004534	六角穴ボルト / M6 × 14	BOLT	1
09	274004	レバー	LEVER	1
10	274005A	ネジリバネ	SPRING	1
11	274006	リンク	LINK	1
12	274007	レバー	LEVER	1
13	007060	段付ネジ / M10	SCREW	1
14	274008	ネジリバネ	SPRING	1
15	274009	ストッパー	STOPPER	1
16	007020A	平ネジ / M4 × 10	SCREW	2
17	007175	平ネジ / M5 × 24	SCREW	1
18	004805	六角ナット / M5	NUT	1
19	274011-91	押エ棒	PRESSER BAR	1
20	208773	圧縮バネ	SPRING	1
21	274014A	調節ネジ	ADJUSTING SCREW	1
22	274015	ナット	NUT	1
23	007171	段付ネジ / M4	SCREW	1
24	274017	ネジリバネ	SPRING	1
25	274010	ストッパー	STOPPER	1
26	007019A	平ネジ / M4 × 8	SCREW	8
27	274018-92B	ホルダー	HOLDER	1
28	007013	平ネジ / M3.5 × 8	SCREW	1
29	274019	板バネ	FLAT SPRING	1
30	005089	平ネジ / C3 × 5.45	SCREW	1
31	274033A	フィンガーガード	FINGER GUARD	1
32	274020	ストッパー	STOPPER	1
33	007008	平ネジ / M3 × 4	SCREW	1
34	007009	平ネジ / M3 × 5	SCREW	1

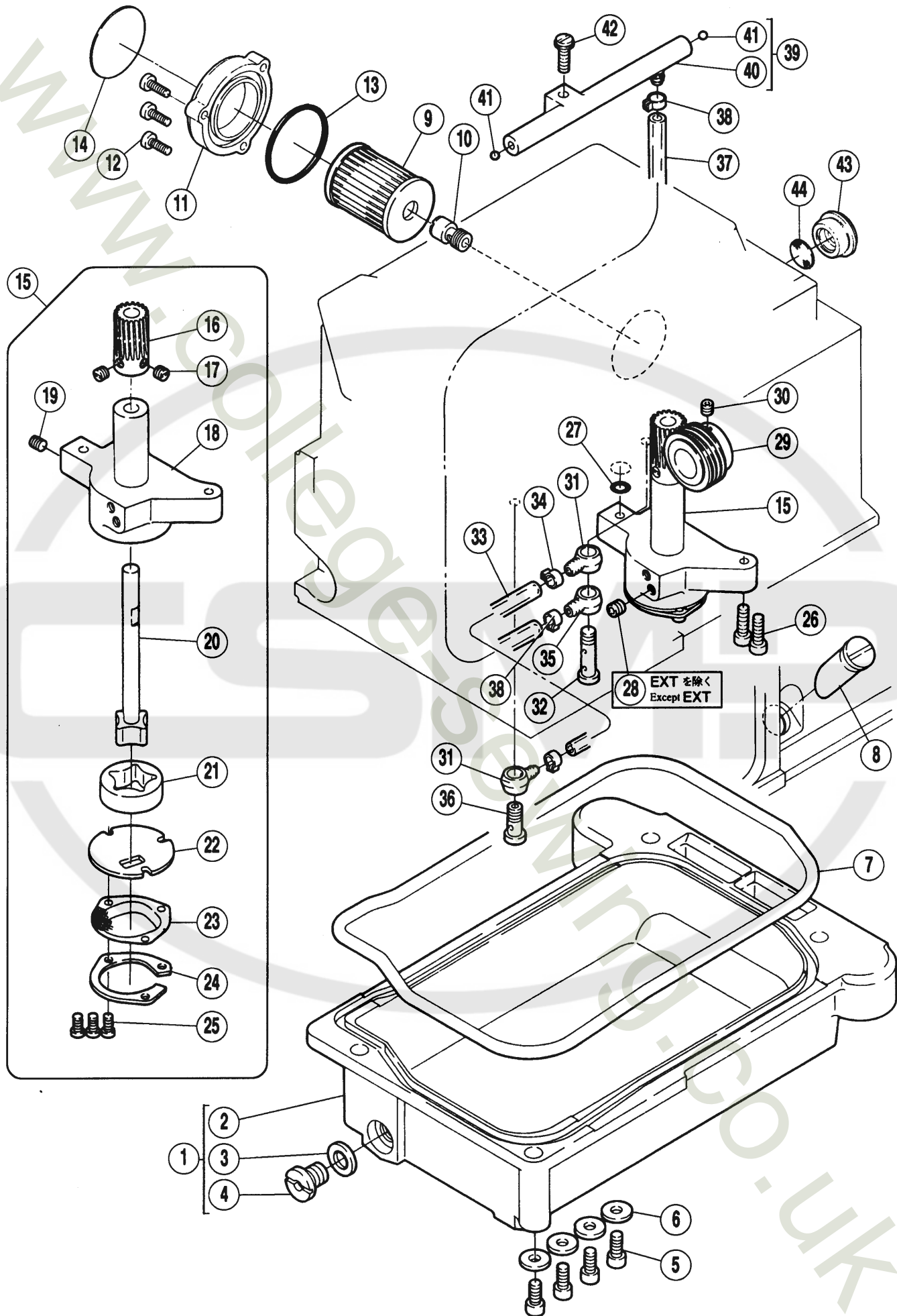

REF. NO.	PART NO. 部品番号	名称	NAME	QT.
01	274587-91	オイルパン (組)	OIL RESERVOIR ASSEMBLY	1
*02	274582	オイルパン	OIL RESERVOIR	1
03	202287A	座金	WASHER	1
04	005138B	平ネジ / H11 × 12	SCREW	1
05	004531	六角穴ボルト / M5 × 12	BOLT	4
06	240339	座金	WASHER	4
07	274583	ガスケット	GASKET	1
08	274539	オイルゲージ	OIL SIGHT GAUGE	1
09	206233	エレメント	OIL FILTER	1
10	274528A	継手	JOINT	1
11	210201-SD	フィルタ - 蓋	OIL FILTER CAP	1
12	007021A	平ネジ / M4 × 12	SCREW	3
13	206431	Oリング	O RING	1
14	9A3002	フィルタ - シール	FILTER SEAL	1
15	274546-91	ポンプ (組)	OIL PUMP ASSEMBLY	1
16	211618	ウォームホイール	WORM WHEEL	1
17	005060	止ネジ / C8 × 4.5	SCREW	2
*18	274547	ポンプ本体	PUMP BODY	1
19	004522	止ネジ / M6 × 6	SCREW	1
20	212978-91	ロータ - (内) 軸	ROTOR (INSIDE) SHAFT	1
21	212981	ロータ - (外)	ROTOR (OUTSIDE)	1
*22	274508	側板	CASING PLATE	1
23	213578	フィルタ -	FILTER	1
24	213579	当金	GUIDE	1
25	007013A	平ネジ	SCREW	3
26	004529	六角穴ボルト / M4 × 16	BOLT	2
27	204185	Oリング	O RING	1
28	004522	止ネジ / M6 × 6	SCREW	1
29	274507A	ウォーム	WORM	1
30	004514	止ネジ / M5 × 5	SCREW	1
31	200136	継手	JOINT	2
32	274586	継手ネジ	SCREW	1
33	200140A	給油パイプ	OIL TUBE	1
34	202199	クランプ	CLAMP	2
35	200136	継手	JOINT	1
36	240328	継手ネジ	SCREW	1
37	206840	給油パイプ (下)	OIL TUBE	1
38	202199	クランプ	CLAMP	2
39	274591-91	油配分器 (組)	OIL DISTRIBUTOR COMPLETE	1
*40	274590	油配分器	OIL DISTRIBUTOR	1
41	210214	栓	PLUG	2
42	004211-HU	座金組込小ネジ / M4 × 16	SCREW	1
43	275540	栓	PLUG	1
44	275541	フィルタ -	FILTER	1

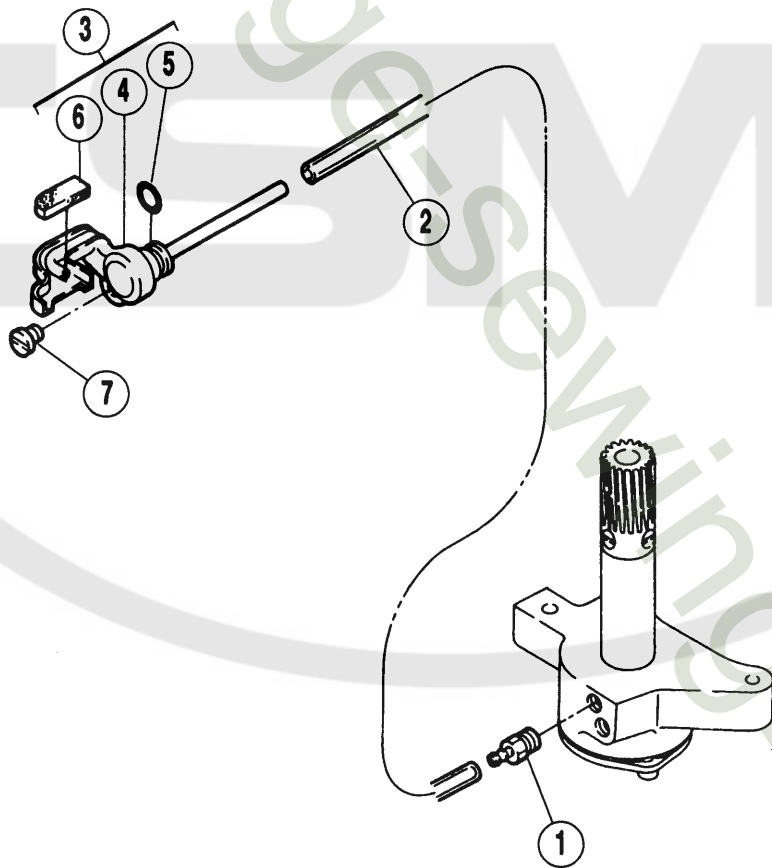
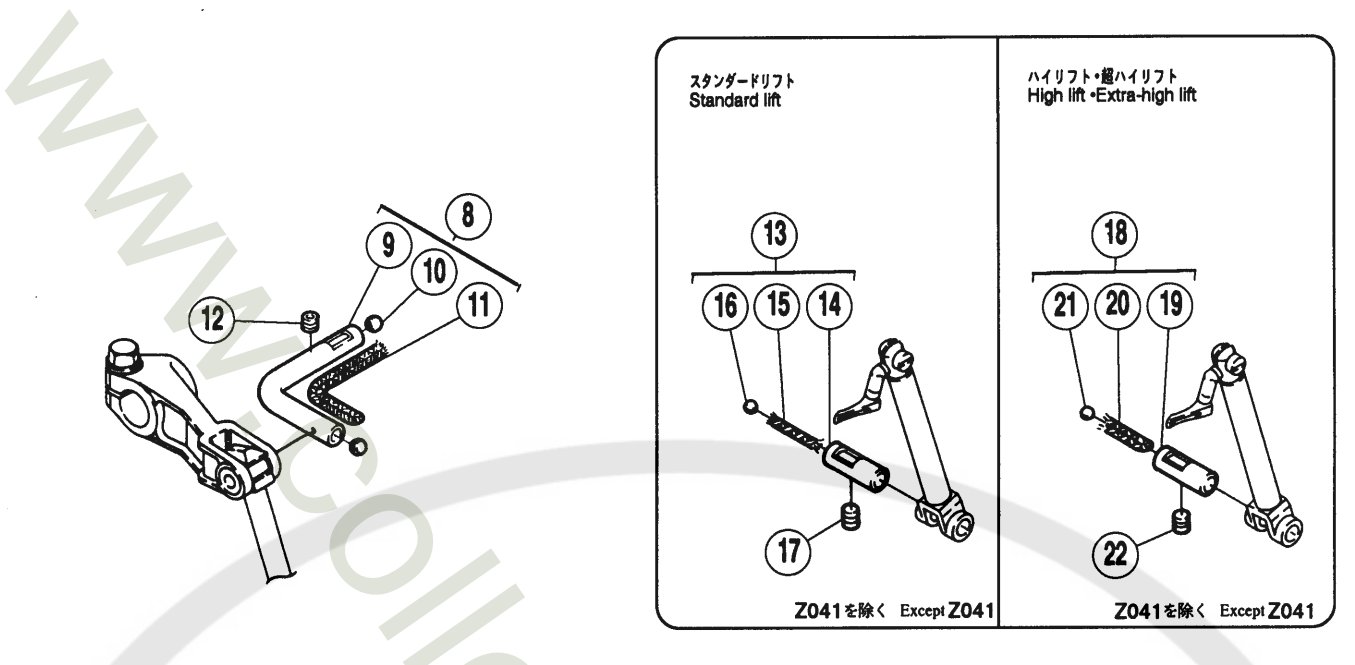

REF. NO.	PART NO. 部品番号	名称	NAME	QT.
01	274592	継手	JOINT	1
*02	274520	チューブ	TUBE	1
03	274584-91	継手 (組)	JOINT ASSEMBLY	1
*04	274585-91	排油継手	JOINT	1
05	204185	Oリング	O RING	1
*06	274522	フェルト	OIL FELT	1
07	007143	平ネジ / M4 × 5.5	SCREW	1
08	274516-91	パイプ (組)	PIPE ASSEMBLY	1
*09	274513	パイプ	PIPE	1
10	240097	栓	PLUG	2
11	202175	給油紐	OIL WICK	1
12	004543	止ネジ / M4 × 4	SCREW	1
13	274517A91	パイプ (組)	PIPE ASSEMBLY	1
*14	274514	パイプ	PIPE	1
15	202175	給油紐	OIL WICK	1
16	240097	栓	PLUG	1
17	004543	止ネジ / M4 × 4	SCREW	1
18	274517-91	パイプ (組)	PIPE ASSEMBLY	1
*19	274514	パイプ	PIPE	1
20	202175	給油紐	OIL WICK	1
21	240097	栓	PLUG	1
22	004543	止ネジ / M4 × 4	SCREW	1

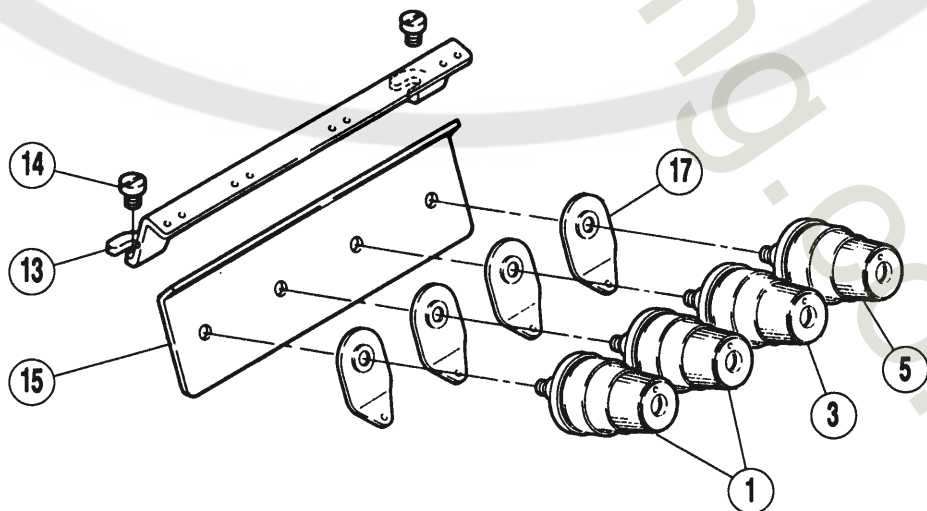
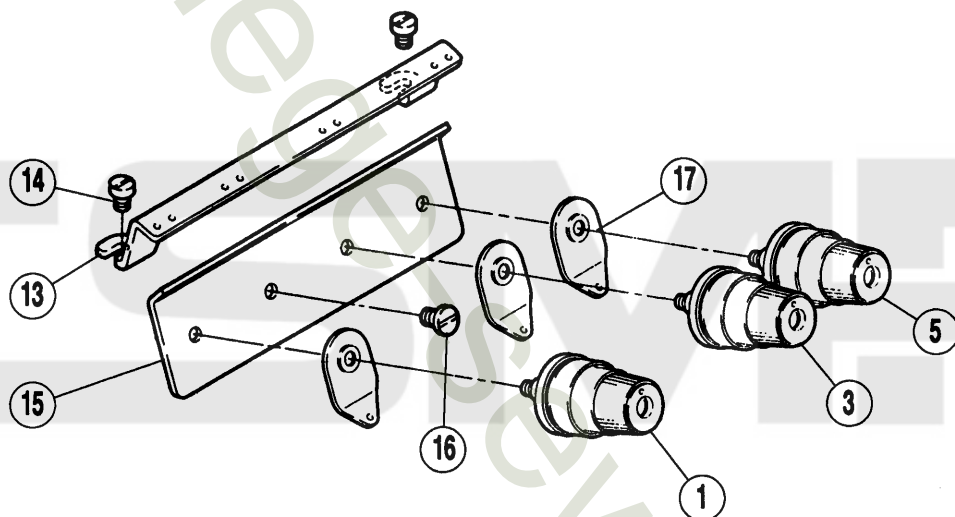
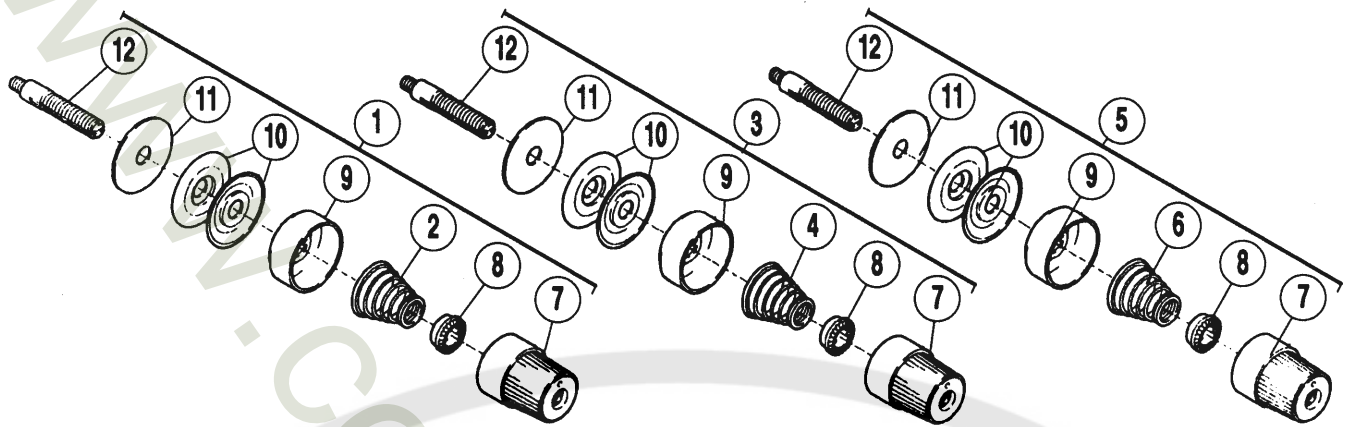

REF. NO.	PART NO. 部品番号	名称	NAME	QT.
01	210529-9U	糸調子 (組)	THREAD TENSION COMPLETE	1
02	201037	圧縮バネ (強)	SPRING (HEAVY)	1
03	210530-9U	糸調子 (組)	THREAD TENSION COMPLETE	1
04	201086	圧縮バネ (中)	SPRING (MEDIUM)	1
05	210531-9U	糸調子 (組)	THREAD TENSION COMPLETE	1
06	201068	圧縮バネ (弱)	SPRING (LIGHT)	1
07	208447-UA	調子ナット	POST NUT	1
08	208448	ラチェット	RATCHET	1
09	208450-UA	受皿	CUP	1
10	210319	調子皿	TENSION DISC	2
11	208449	フェルト	FELT	1
12	005082A	調子棒 / C5	SCREW STUD	1
13	275000	糸道	THREAD EYELET	1
14	007018A	平ネジ / M4 × 6	SCREW	1
15	275001	糸道	THREAD EYELET	1
16	004009-HC	平ネジ / C5 × 7.5	SCREW	1
*17	202849	調子台	TENSION GUIDE	1

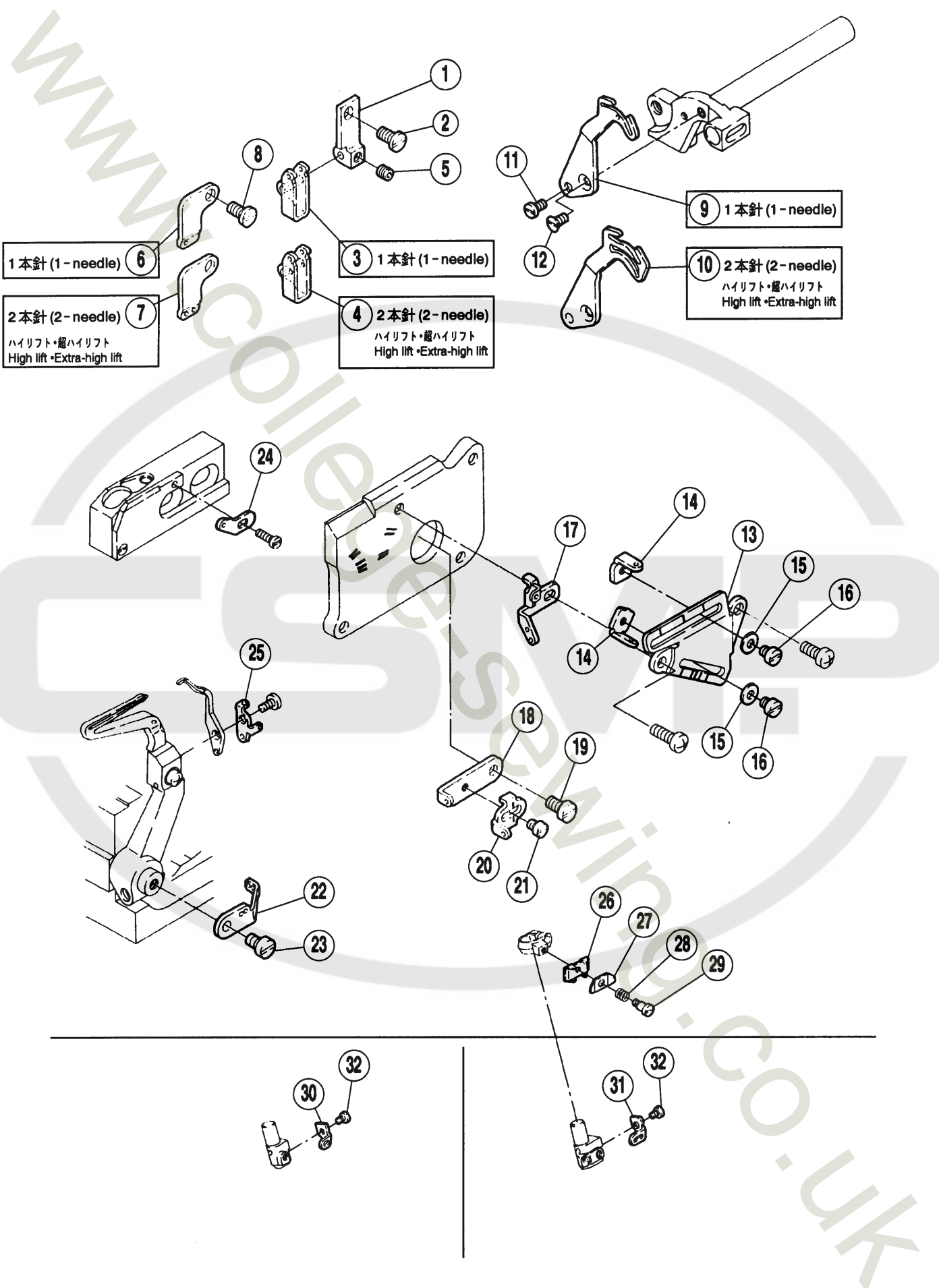

REF. NO.	PART NO. 部品番号	名称	NAME	QT.
01	275015	ブラケット	BRACKET	1
02	007082	平ネジ / M4 × 8	SCREW	1
03	275013A	糸道	THREAD EYELET	1
04	275013	糸道	THREAD EYELET	1
05	004543	止ネジ / M4 × 4	SCREW	1
06	275018	糸道	THREAD EYELET	1
07	275018A	糸道	THREAD EYELET	1
08	007082	平ネジ / M4 × 8	SCREW	1
09	275016A	針糸繰り	THREAD TAKEUP	1
10	275017A	針糸繰り	THREAD TAKEUP	1
11	007062	平ネジ / M3 × 6	SCREW	1
12	007041	皿ネジ / M3 × 6	SCREW	1
13	275004	ブラケット	BRACKET	1
14	275047	糸道	THREAD GUIDE (RIGHT)	2
15	202875	座金	WASHER	2
16	007008	平ネジ / M3 × 4	SCREW	2
17	275107	糸道	THREAD GUIDE	1
18	275005	糸繰り	THREAD TAKEUP	1
19	007019	平ネジ / M4 × 8	SCREW	1
20	275006	糸道	THREAD EYELET	1
21	007008	平ネジ / M3 × 5	SCREW	1
22	275108	糸繰り	THREAD TAKEUP	1
23	007018	止ネジ / M4 × 6	SCREW	1
24	275010	糸道	THREAD EYELET	1
25	275109	糸道	THREAD EYELET	1
26	275011	小調子台	BRACKET	1
27	275012	小調子皿	THREAD RETAINER	1
28	240326	圧縮バネ	SPRING	1
29	007163	段付ネジ / M2	SCREW	1
30	275019A	糸道	THREAD GUIDE	1
31	275019B	糸道	THREAD GUIDE	1
32	007120	平ネジ / M2 × 3	SCREW	2

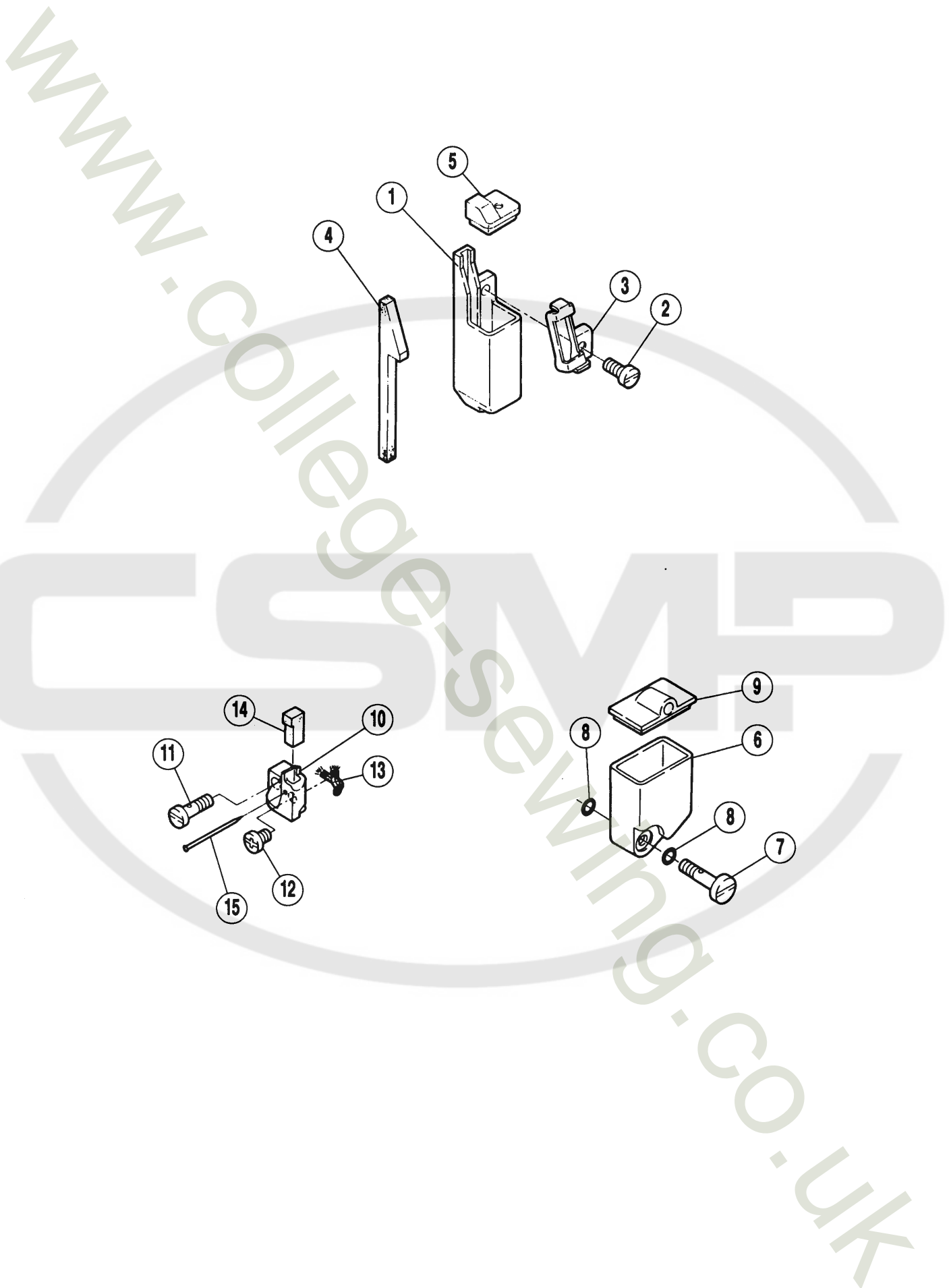

REF. NO.	PART NO. 部品番号	名称	NAME	QT.
01	275500	シリコンタンク (上)	SILICONE OIL RESERVOIR (UPPER)	1
02	007020	平ネジ / M4 × 10	SCREW	1
03	275502	糸案内	THREAD GUIDE	1
04	275503	フェルト	FELT	1
05	275501	蓋	CAP	1
06	275570	シリコンタンク (下)	SILICONE OIL RESERVOIR (UPPER)	1
07	275572	継手ネジ	SCREW	1
08	208949	Oリング	O RING	2
09	275571	蓋	CAP	1
*10	275576-91	針冷却器	NEEDLE COOLER	1
11	275573	継手ネジ	SCREW	1
12	007017A	平ネジ / M4 × 5	SCREW	1
13	202174	給油紐	OIL WICK	1
14	213090	フェルト	OIL FELT	1
15	210766	止ピン	PIN	1

裾引き (Blindstitch hemming)

EX5105 - 12

EX5114 - 92M2

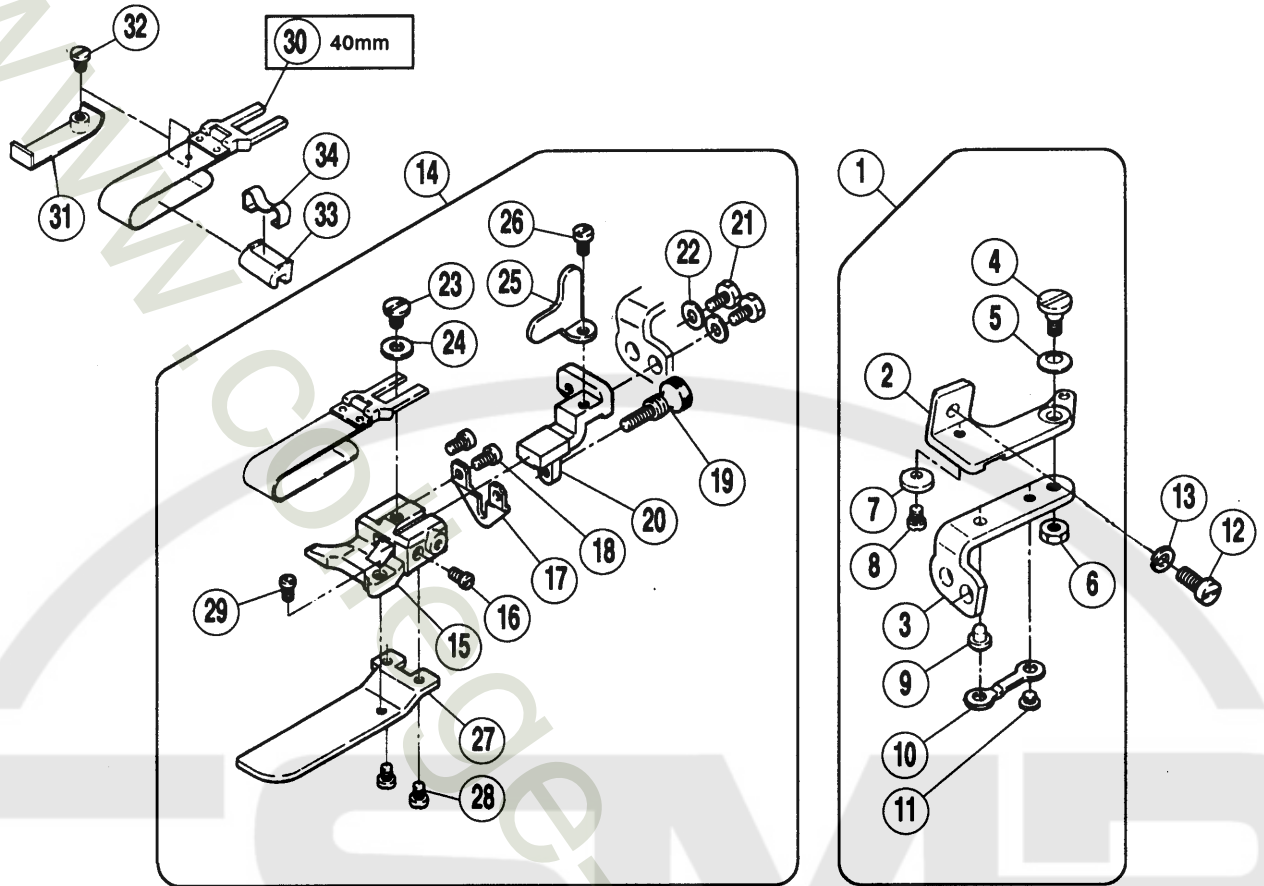

当定規 (Fabric edge guide)

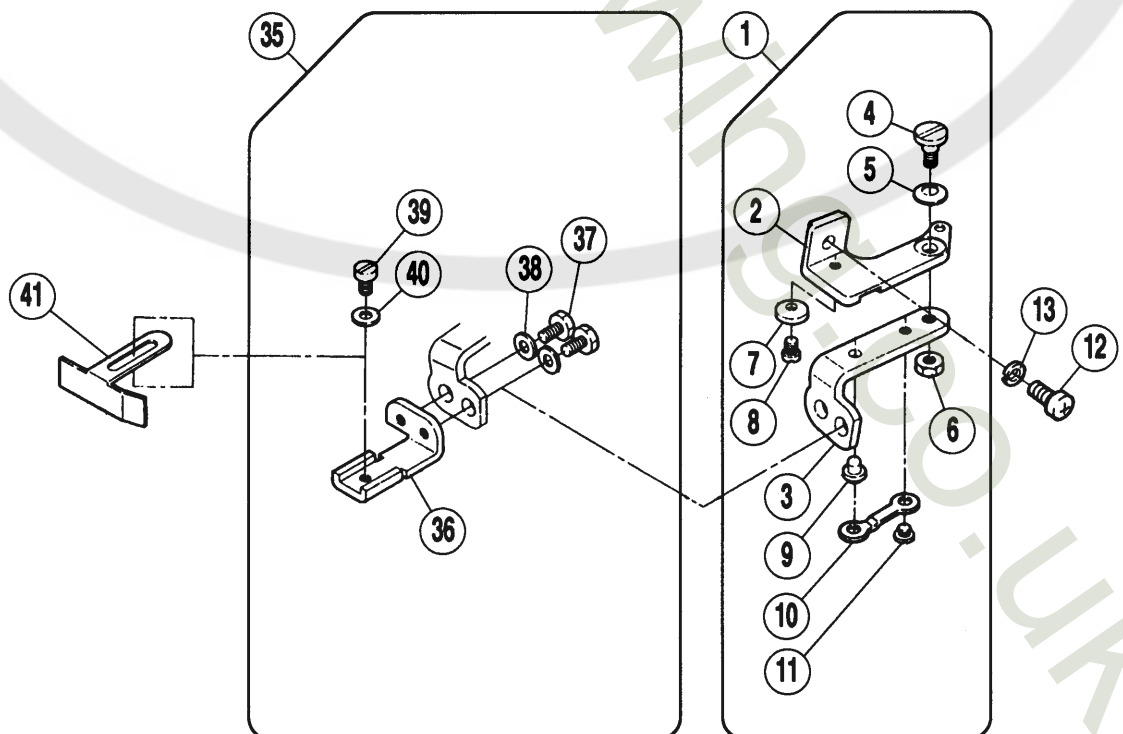

裾引き用アタッチメント
当定規

ATTACHMENT FOR BLINDHEMMING
FABRIC EDGE GUIDE

REF. NO.	PART NO. 部品番号	名称	NAME	QT.
01	210685	定規ブラケット (組)	CLOTH GUIDE BRACKET ASSEMBLY	1
02	210680	定規ブラケット	CLOTH GUIDE BRACKET	1
*03	210681	ヒンジ/定規ブラケット	HINGE/EDGE GUIDE BRACKET	1
04	005184	段付ネジ/C5	SCREW	1
05	201191	皿バネ	SPRING	1
06	003044	六角ナット/C5	NUT	1
07	210682	ストッパー/ヒンジ	STOPPER	1
08	005053	平ネジ/C4×4.8	SCREW	1
09	210683	段付ピン	PIN	1
10	210684	板バネ	FLAT SPRING	1
11	002906	平ネジ/C4×2.6	SCREW	1
12	007020	平ネジ/M4×10	SCREW	1
13	201252	バネ座金	SPRING WASHER	1
14	210691A91	裾引定規台 (組)	CLOTH GUIDE COMPLETE	1
*15	205361A	定規台	CLOTH GUIDE	1
16	005057	平ネジ/C3×5	SCREW	1
17	210689	調節板	ADJUSTING PLATE	1
18	005157	平ネジ/C3×4.5	SCREW	2
19	002430	調節ネジ/C3	SCREW	1
20	210690	ブラケット	BRACKET	1
21	005088	六角ネジ/C4×7.5	SCREW	2
22	167066	座金	WASHER	2
23	002905	平ネジ/C5×4.5	SCREW	1
24	137142	座金	WASHER	1
25	210692	ストッパー	STOPPER	1
26	001206	平ネジ/C4×5.3	SCREW	1
27	213095	補助板	AUXILIARY PLATE	1
28	001229	平ネジ/C3×4.5	SCREW	2
29	005057	平ネジ/C3×5	SCREW	1
30	201211C91	定規羽根 (40MM)	FOLDER COMPLETE (40MM)	1
31	205835	補助羽根	AUXILIARY PLATE	1
32	005299	平ネジ/C3×2.6	SCREW	1
33	303312A	羽根駒	REGULATOR	1
34	303313	板バネ	FLAT SPRING	1
35	210686	当定規台 (組)	BRACKET COMPLETE/EDGE GUIDE	1
36	210687	当定規台	BRACKET/EDGE GUIDE	1
37	005088	六角ネジ/C4×7.5	SCREW	2
38	167066	座金	WASHER	2
39	001202	平ネジ/C4×7	SCREW	1
40	167066	座金	WASHER	1
41	204667	当定規	EDGE GUIDE	1

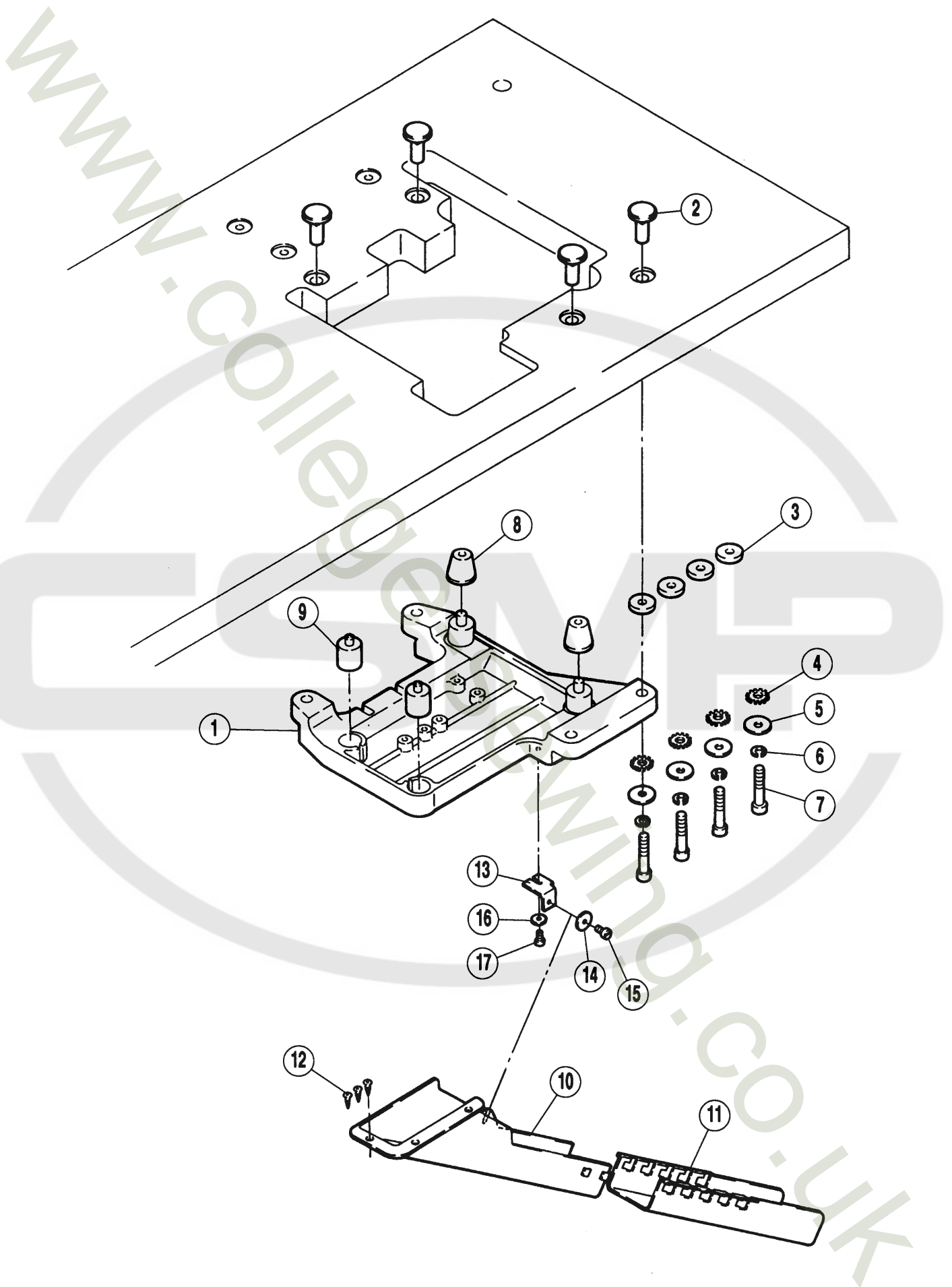

REF. NO.	PART NO. 部品番号	名称	NAME	QT.
01	276017	据付板	REST BOARD	1
02	206336	半沈用ナット	NUT	4
03	205467	スペーサー	SPACER	4
04	240304	歯付座金	WASHER	4
05	206337	座金	WASHER	4
06	201477	バネ座金	SPRING WASHER	4
07	004575	六角穴ボルト / M8 × 45	BOLT	4
08	179483-05	クッションゴム	CUSHION RUBBER	2
09	205473	防振ゴム	CUSHION RUBBER	2
10	276002-UA	シューター (上)	WASTE CHUTE	1
11	276003-UA	シューター (下)	WASTE CHUTE	1
12	004904	木ネジ (Ⅲ) / 3.5	SCREW	3
13	276004	取付板	BRACKET	1
14	303026	座金	WASHER	1
15	004109	平ネジ / M4 × 10	SCREW	1
16	240104	座金	WASHER	1
17	004109	平ネジ / M4 × 10	SCREW	1

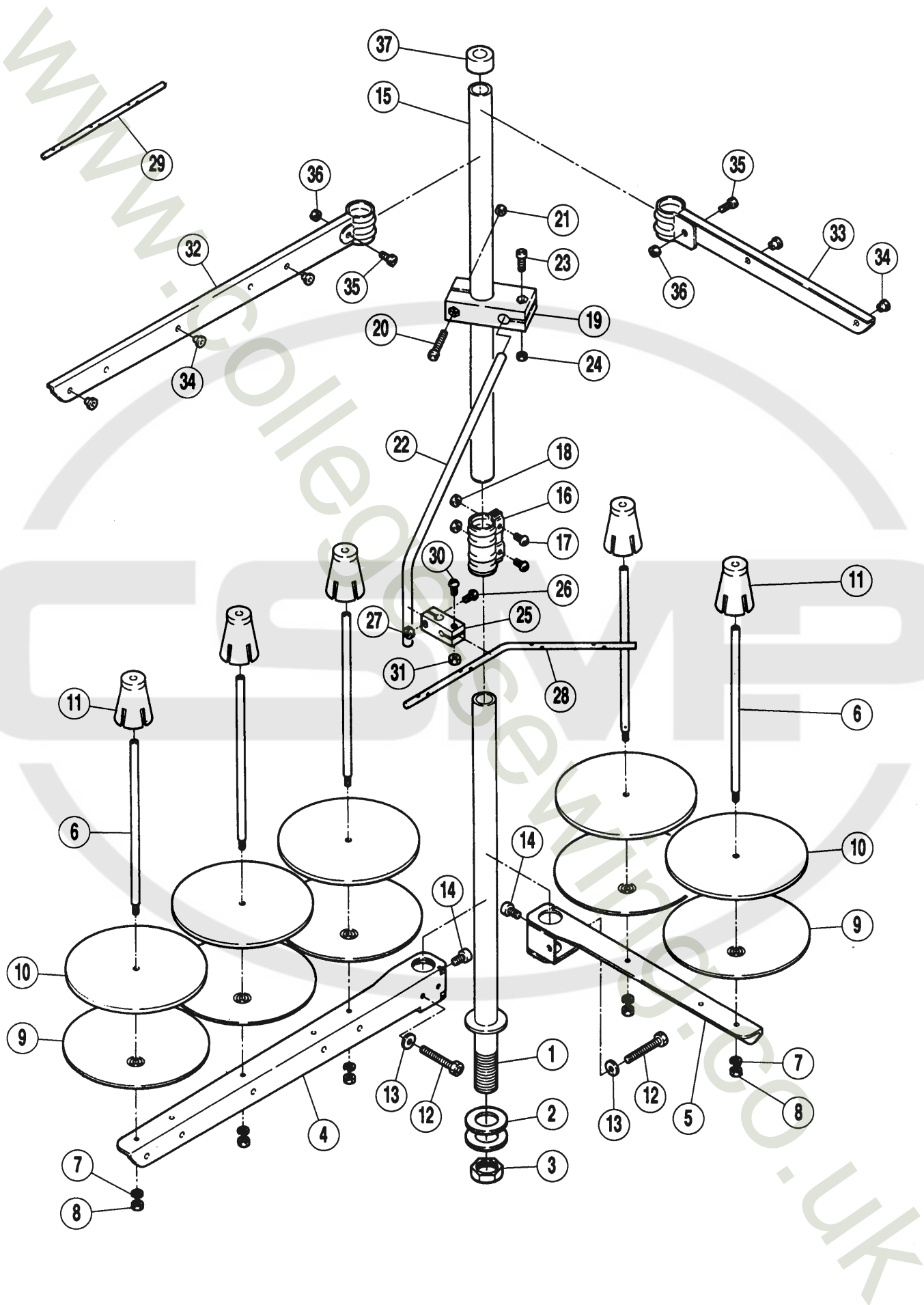

糸立台

THREAD STAND

REF. NO.	PART NO. 部品番号	名称	NAME	QT.
	000486B9S	糸立 (組) (4本立)	THREAD STAND ASS. (4-SPOOLS)	1
	000486C9S	糸立 (組) (3本立)	THREAD STAND ASS. (3-SPOOLS)	1
01	000503-SA	スタンド棒 (下)	THREAD STAND ROD (LOWER)	1 1
02	000509	座金	WASHER	2 2
03	005476	六角ナット	NUT	1 1
04	000505-SA	ブラケット (3本立)	BRACKET	1
05	000505ACA	ブラケット (2本立)	BRACKET	2
06	000380A	糸立棒	SPOOL PIN	3 4
07	201252	バネ座金	SPRING WASHER	3 4
08	004803	六角ナット / M4	NUT	3 4
09	000381-SA	受皿	SPOOL TRAY	3 4
10	000507	ウレタン	CUSHION	3 4
11	000382-SA	ユレ止め	SPOOL RETAINING FIN	3 4
12	007102	六角ネジ / M6 × 32	SCREW	1 2
13	000512	座金	WASHER	1 2
14	004022	平ネジ / M6 × 10	SCREW	1 2
15	000502-SA	スタンド棒 (上)	THREAD STAND ROD (UPPER)	1 1
16	000504-SA	ジョイント	JOINT	1 1
17	004021	平ネジ / M5 × 16	SCREW	2 2
18	004805	六角ナット / M5	NUT	2 2
19	000383-SA	ブラケット	BRACKET	1 1
20	004014	平ネジ / M4 × 25	SCREW	1 1
21	004803	六角ナット / M4	NUT	1 1
22	000384	糸道棒腕	THREAD GUIDE BAR ROD	1 1
23	004012	平ネジ / M4 × 12	SCREW	1 1
24	004803	六角ナット / M4	NUT	1 1
25	000233-SA	ホルダー	HOLDER	1 1
26	004012	平ネジ / M4 × 12	SCREW	1 1
27	004803	六角ナット / M4	NUT	1 1
28	000293B	糸道棒 (4本立)	THREAD GUIDE BAR (4-SPOOLS)	1
29	000293C	糸道棒 (3本立)	THREAD GUIDE BAR (3-SPOOLS)	1
30	004012	平ネジ / M4 × 12	SCREW	1 1
31	004803	六角ナット / M4	NUT	1 1
32	000527-SA	ブラケット (3本立)	BRACKET	1
33	000527ACA	ブラケット (2本立)	BRACKET	2
34	000506	糸目穴	THREAD EYELET	3 4
35	004117	平ネジ / M5	SCREW	1 2
36	004805	六角ナット / M5	NUT	1 2
37	000386	キャップ	ROD CAP	1 1

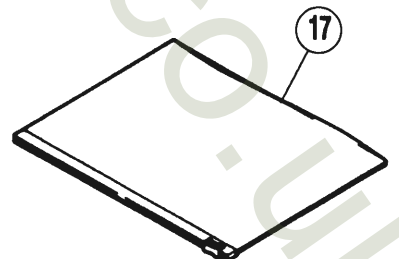
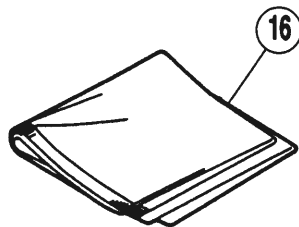
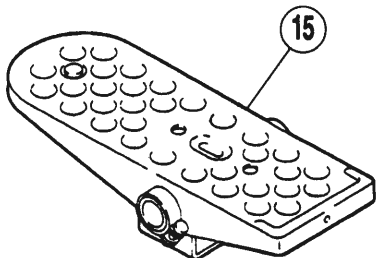
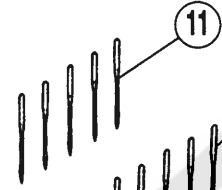
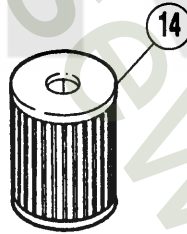
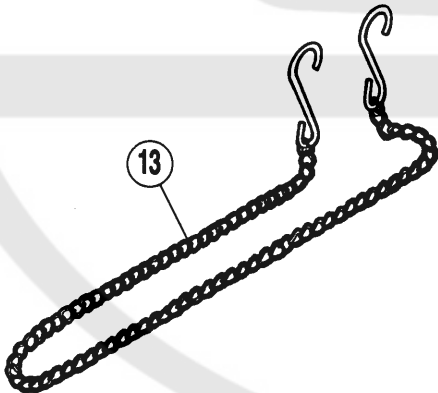
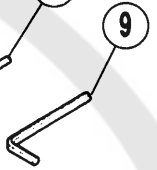
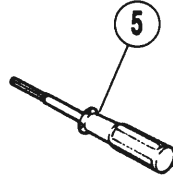
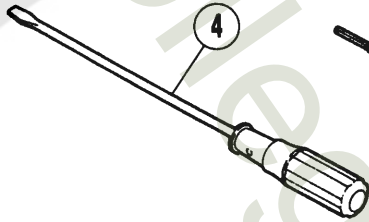
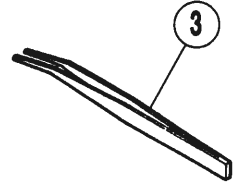
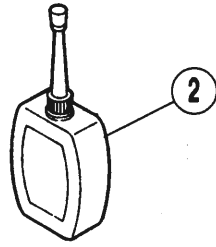
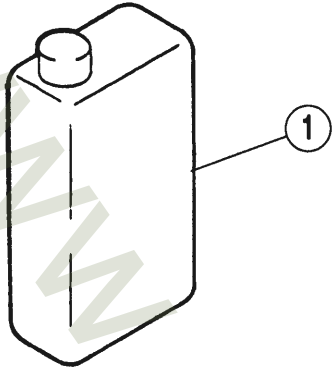

付属品

ACCESSORIES

REF. NO.	PART NO. 部品番号	名称	NAME	QT.
01	000453	油缶 / 1000CC	OIL CONTAINER/1000CC	1
02	000178	シリコンオイル / 50CC	CONTAINER - SILICONE	1
03	000131	ピンセット	TWEEZERS	1
04	000127	ドライバー (大)	SCREWDRIVER (LARGE)	1
05	000474	キーレンチドライバー	ALLEN KEY DRIVER/1.5MM	1
06	000285	スパナ / 8MM	WRENCH/8MM	1
07	000464	キーレンチ / 2MM	ALLEN KEY/2MM	1
08	000271	キーレンチ / 4MM	ALLEN KEY/4MM	1
09	000272	キーレンチ / 6MM	ALLEN KEY/6MM	1
10	213108	下メス	LOWER KNIFE	1
*11	000642B	針 DC × 27 # 9	NEEDLE	1
*12	000629B	針 DC × 27 # 11	NEEDLE	1
13	000392	鎖	CHAIN	1
14	206233	エレメント	OIL FILTER	1
15	000480	ペダル	PEDAL	1
16	000908	ナイロンカバー (中)	DUST COVER	1
17	000482	アクセサリバッグ	ACCESSORY BAG	1

地縫い (Plain seaming)

EX5104 - 02・04

EX5114 - 03・04

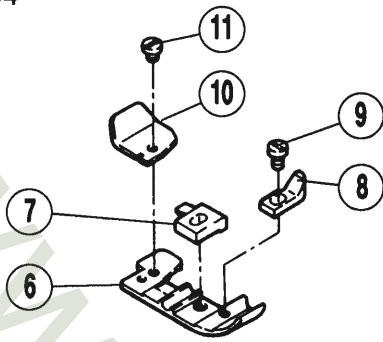

裾引き (Blindstitch hemming)

EX5105 - 12

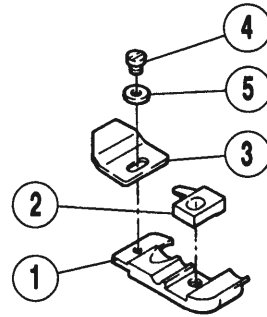

テープ付 (Attaching tape)

EX5104 - 52D

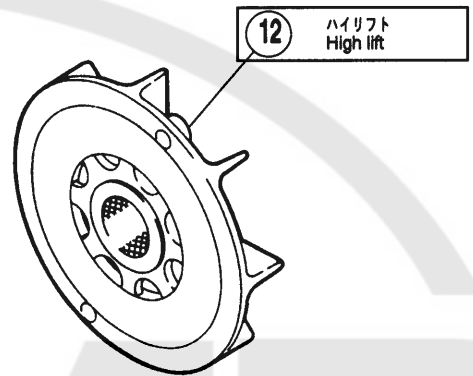
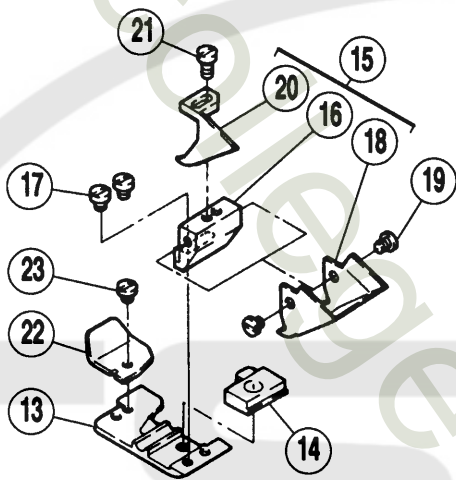

多用途 (Versatile)

EX5114 - 92M2

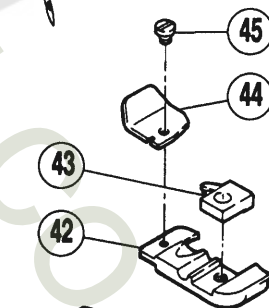
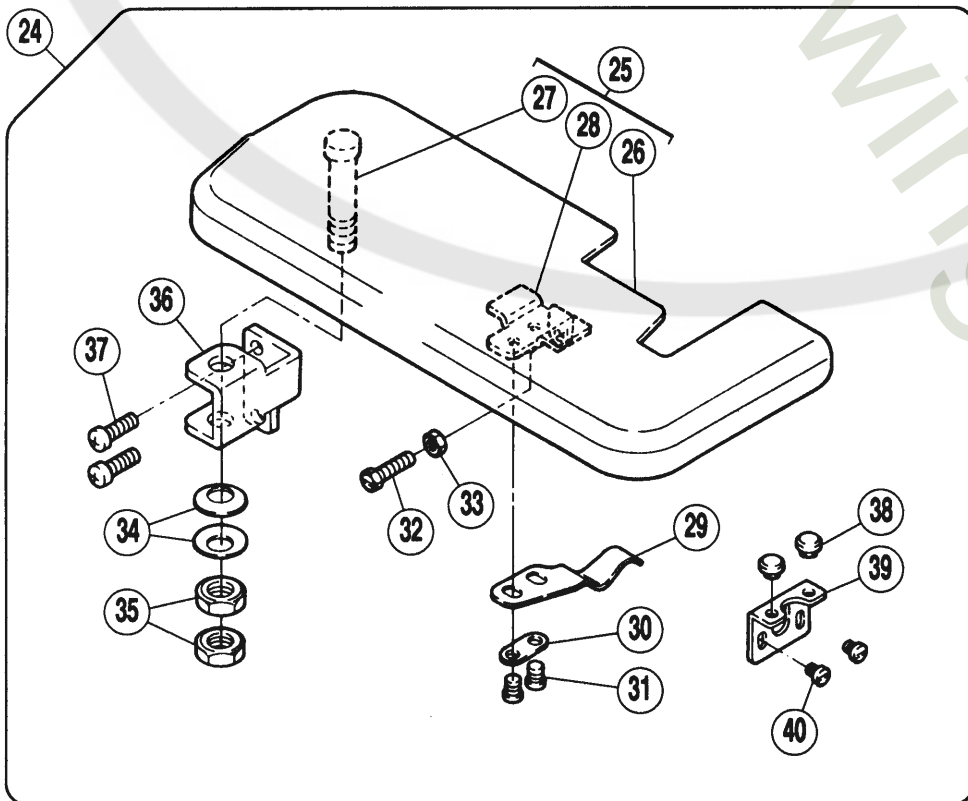

REF. NO.	PART NO. 部品番号	名称	NAME	QT.
01	201152E	押エ	PRESSER FOOT	1
02	277115	押エ爪	PRESSER FOOT FINGER	1
03	210584	押エ補助板	UNCURLER	1
04	005030	平ネジ / C1 × 2.3	SCREW	1
05	210585	座金	WASHER	1
06	201152E	押エ	PRESSER FOOT	1
07	277115	押エ爪	PRESSER FOOT FINGER	1
08	211557	補助押エ	FABRIC GUARD	1
09	001333	平ネジ / C1 × 4	SCREW	1
10	211600	押エ補助板	UNCURLER	1
11	005030	平ネジ / C1 × 2.3	SCREW	1
12	305276-91	ファン (組)	FAN COMPLETE	1
13	213672	押エ	PRESSER FOOT	1
14	210371B	押エ爪	PRESSER FOOT FINGER	1
15	213679-91	ガイド (組)	GUIDE PLATE ASSEMBLY	1
16	213673	ブラケット	BLACKET	1
17	007078	平ネジ / M2.5 × 3	SCREW	2
18	213674	案内	GUIDE	1
19	005615	平ネジ	SCREW	2
20	213675	案内	GUIDE	1
21	002922	平ネジ / C1 × 5.5	SCREW	1
22	211600	押エ補助板	UNCURLER	1
23	005030	平ネジ / C1 × 2.3	SCREW	1
24	270174-91	クロスプレート (組)	CLOTH PLATE ASSEMBLY	1
25	270170-91	クロスプレート	CLOTH PLATE SET	1
*26	270171	クロスプレート本体	CLOTH PLATE	1
*27	270172	ヒンジピン	PIN	1
28	213268	ブラケット	BLACKET	1
29	204218	板バネ	FLAT SPRING	1
30	200162A	座金	WASHER	1
31	005053	平ネジ / C4 × 4.8	SCREW	2
32	005121A	六角ネジ / C4 × 16	SCREW	1
33	003091	六角ナット / C4	NUT	1
34	204888	皿バネ	SPRING WASHER	2
35	004808	六角ナット / M8	NUT	2
36	270173	ブラケット	BLACKET	1
37	007022A	平ネジ	SCREW	2
38	240305	防振ゴム	CUSHION RUBBER	2
39	305014	ブラケット	BRACKET	1
40	007008	平ネジ / M3 × 4	SCREW	2
41	205269	ニードルピン	NEEDLE PIN	1
42	201152E	押エ	PRESSER FOOT	1
43	210373	押エ爪	PRESSER FOOT FINGER	1
44	211600	押エ補助板	UNCURLER	1
45	005030	平ネジ / C1 × 2.3	SCREW	1
46	275017A	針糸繰り	THREAD TAKEUP	1

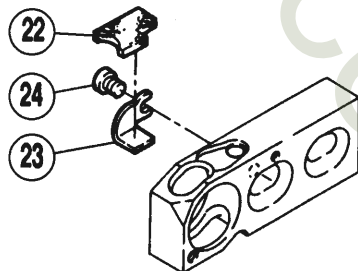
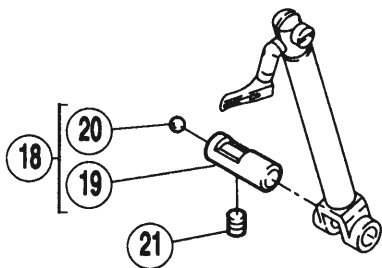
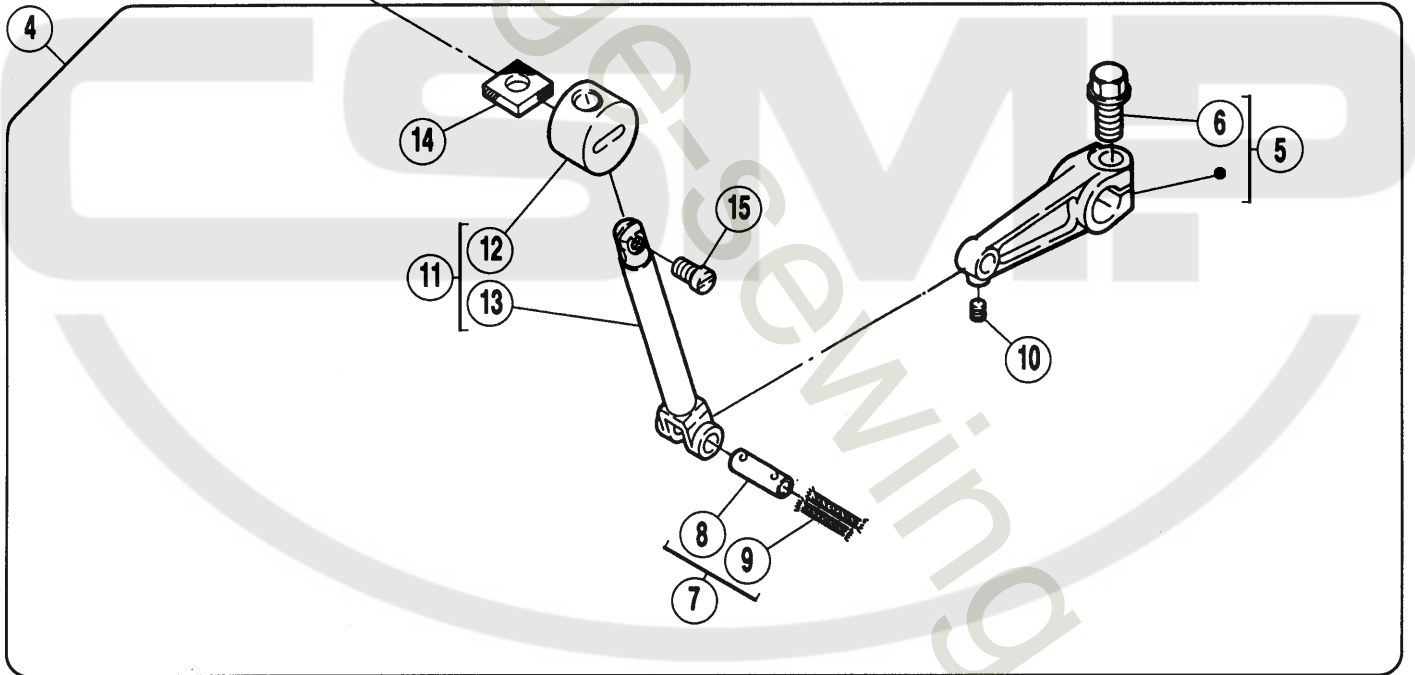
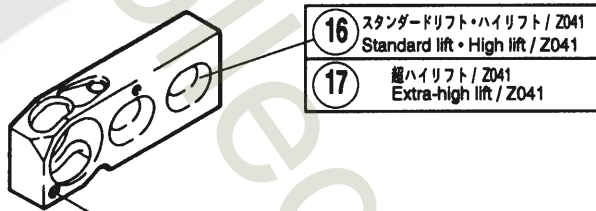
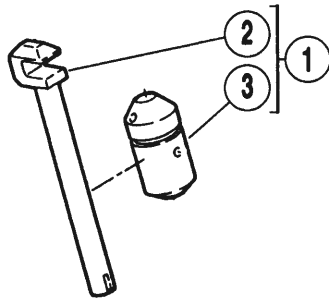

REF. NO.	PART NO. 部品番号	名称	NAME	QT.
01	271005B91	針棒・ブッシュ (組)	BUSHING ASSEMBLY	1
02	271006-C	針棒	NEEDLE BAR	1
03	271007	ブッシュ	BUSHING	1
04	271538A91	上ルーパ-台セット	UPPER LOOPER HOLDER ASSEMBLY	1
05	271505-92	レバ-	LEVER	1
06	007150	六角ボルト/M6×12	BOLT	1
07	179136-01	平行ピン (組)	PIN ASSEMBLY	1
08	179137-05	平行ピン	PIN	1
09	202176	給油紐	OIL WICK	1
10	004545	止ネジ/M3×4	SCREW	1
11	271533A91	上ルーパ-台 (組)	UPPER LOOPER HOLDER ASSEMBLY	1
*12	179129-05	上ルーパ-台案内	GUIDE/UPPER LOOPER HOLDER	1
13	271516A91	上ルーパ-台	UPPER LOOPER HOLDER	1
14	179130-05	フェルト	OIL FELT	1
15	007054	平ネジ/M3.5×6.7	SCREW	1
16	271510M	上ルーパ-土台	BASE/UPPER LOOPER HOLDER	1
17	271510N	上ルーパ-土台	BASE/UPPER LOOPER HOLDER	1
18	274517B91	パイプ (組)	PIPE ASSEMBLY	1
*19	274514A	パイプ	PIPE	1
20	240097	栓	PLUG	1
21	004543	止ネジ/M4×4	SCREW	1
22	274589	フェルト	OIL FELT	1
23	274588	止メ板	PLATE	1
24	007008	平ネジ/M3×4	SCREW	1

地縫用 (1本針)
 テープ付用
 裾引用

EX5100 Series

Plain seaming (1-Needle)
 Attaching tape
 Blindstitch hemming

EX5104-02/233N

EX5104-04/433N

EX5104-52D/333

EX5104-04/433

EX5105-12/223N

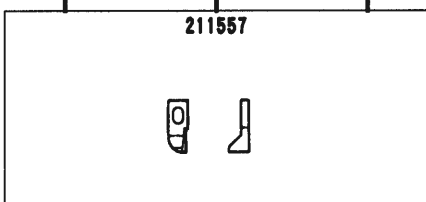
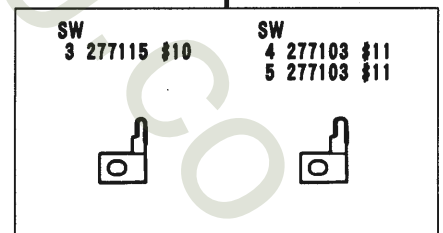
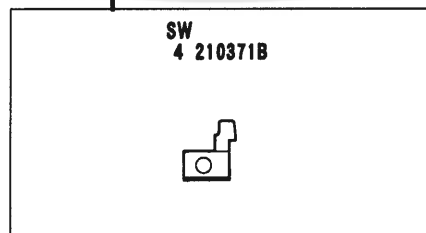
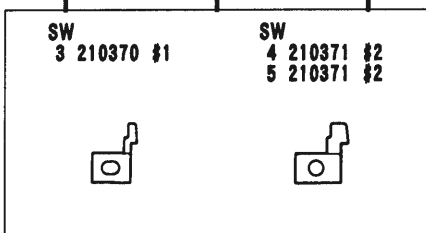
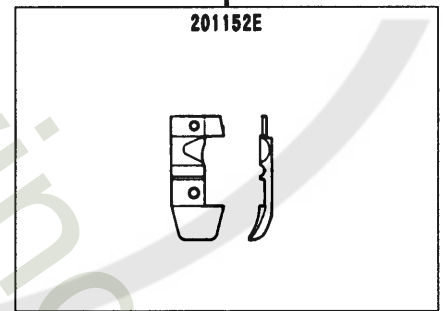
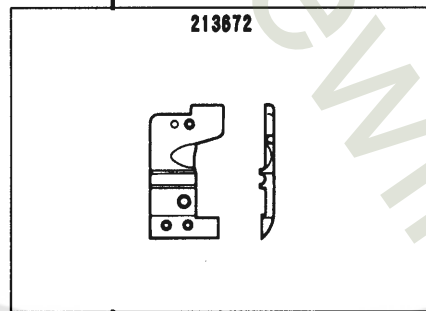
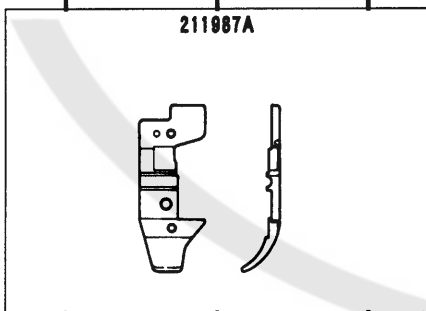
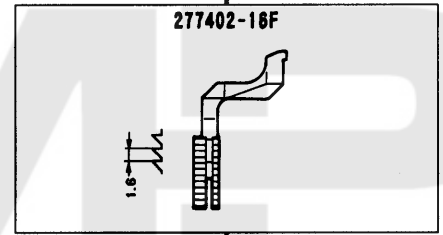
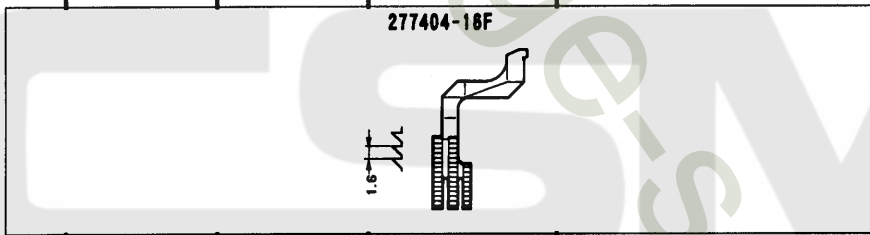
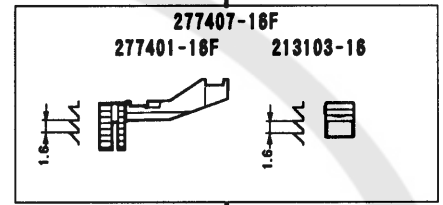
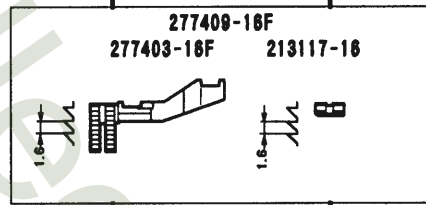
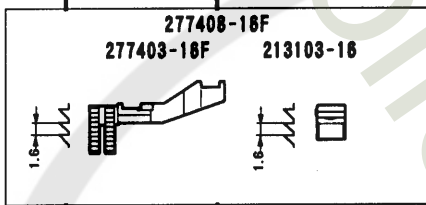
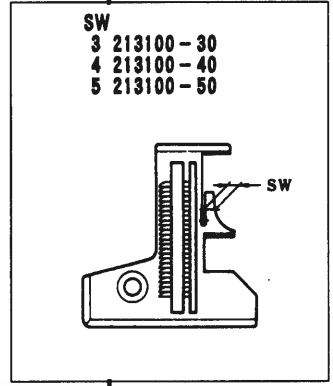
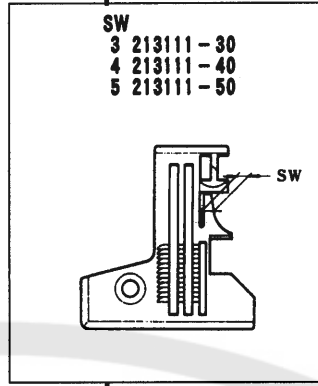
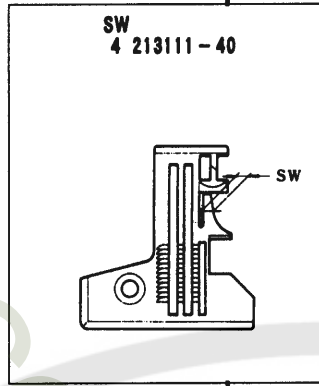
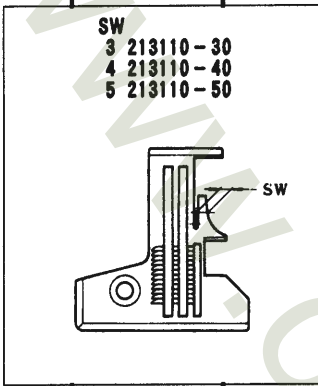

EX5104-02/233N EX5105-12/223N EX5104-04/433 EX5104-04/433N EX5104-52D/333

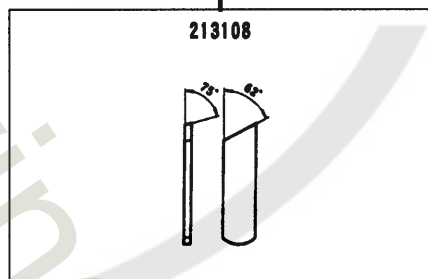
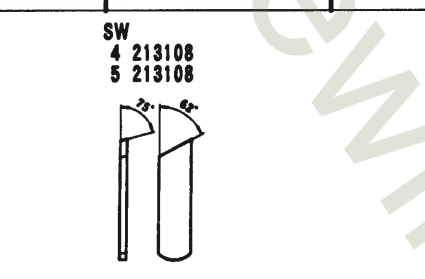
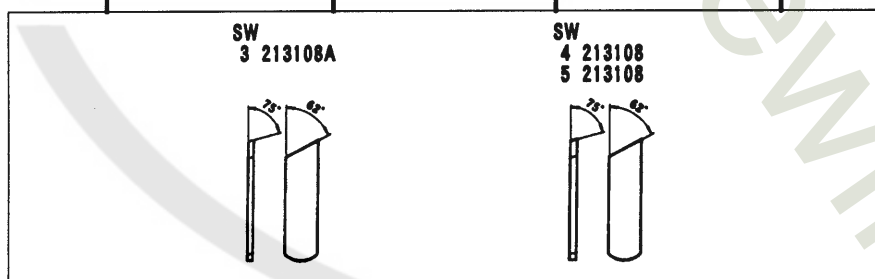
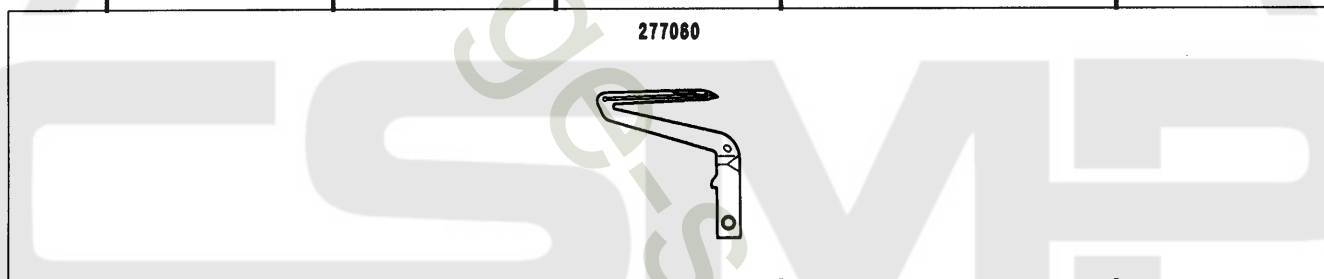
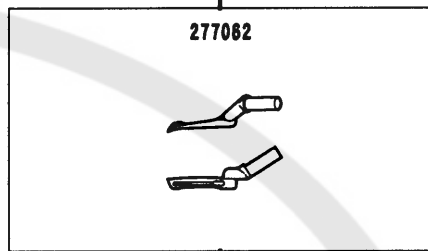
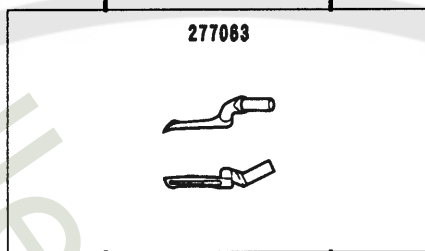
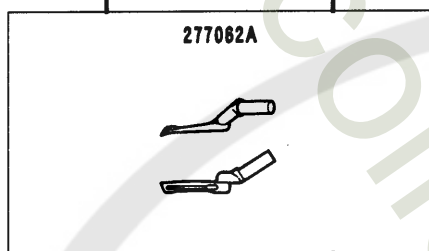
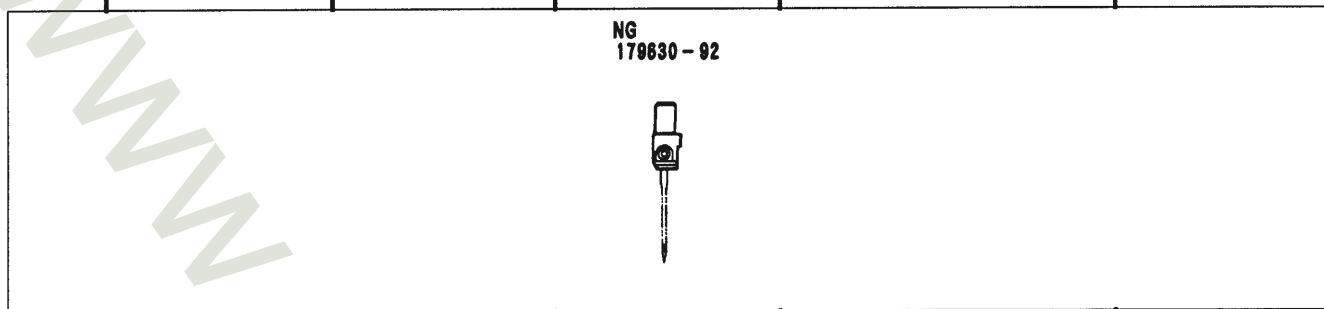

地縫用(薄-中厚生地)
PLAIN SEAMING
(LIGHT-MEDIUM WEIGHT FABRIC)

地縫用(厚-極厚生地)
PLAIN SEAMING
(HEAVY-EXTRA HEAVY FABRIC)

テープ付用(薄-中厚生地)
ATTACHING TAPE
(LIGHT-MEDIUM WEIGHT FABRIC)

裾引用(薄-中厚生地)
BLINDSTITCH HEMMING
(LIGHT-MEDIUM WEIGHT FABRIC)

地縫用(厚-極厚生地)
PLAIN SEAMING
(HEAVY-EXTRA HEAVY FABRIC)

共通部品 COMMON PARTS

上メス UPPER KNIFE
201121A



針受(前) NEEDLE GUARD(FRONT)
213107



針受(後) NEEDLE GUARD(REAR)
277061



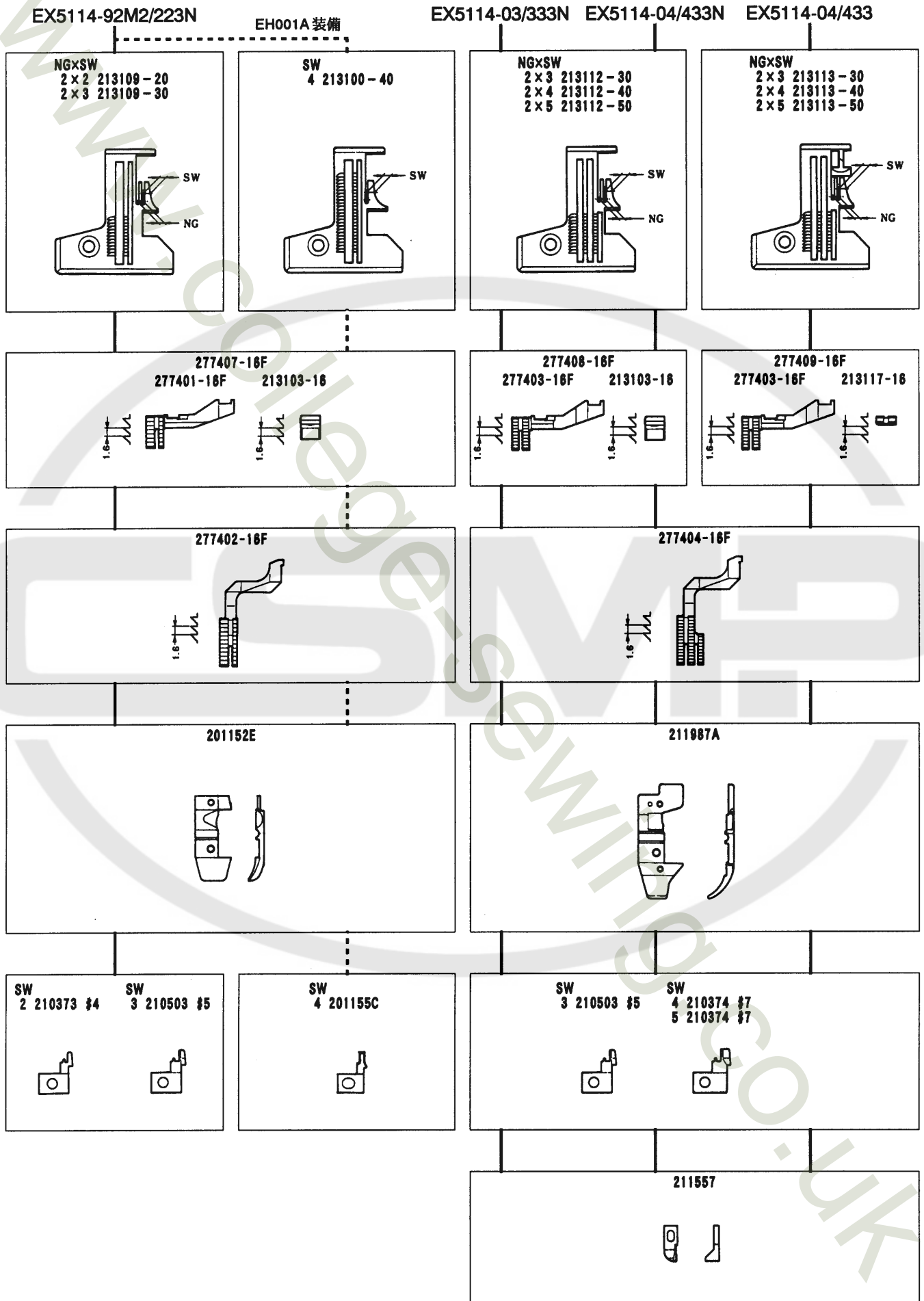

EX5114-03/333N

EX5114-92M2/223N

EX5114-04/433

EX5114-04/433N

NG
277022-92



277062B

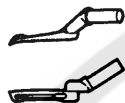

277062C

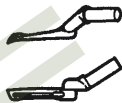

277063



277001

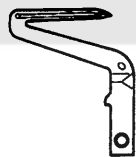

277060

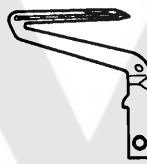

213108



地縫用(中厚~厚生地)
PLAIN SEAMING
(MEDIUM WEIGHT -HEAVY FABRIC)

多用途用(薄~中厚生地)
VERSATILE
(LIGHT-MEDIUM WEIGHT FABRIC)

地縫用(厚~極厚生地)
PLAIN SEAMING
(HEAVY -EXTRA HEAVY FABRIC)

地縫用(厚~極厚生地)
PLAIN SEAMING
(HEAVY -EXTRA HEAVY FABRIC)

共通部品 COMMON PARTS

上メス UPPER KNIFE
201121A



針受(前) NEEDLE GUARD(FRONT)
213107



針受(後) NEEDLE GUARD(REAR)
277081



EX5100 Series
ゲージパーツ表 (1)

EX5100 Series
GAUGE PARTS LIST(1)

形式 MACHINE TYPE /SPEC.	ゲージ		針板 NEEDLE PLATE	主送り歯(組) MAIN FEED DOG ASS.	主送り歯本体 MAIN FEED DOG	補助送り歯 AUX. FEED DOG	差動送り歯 DIFF. FEED DOG	押し PRESSER FOOT	押し爪 PRESSER FOOT FINGER	補助押し UNCURLER
	NG	SW								
EX5104-02/233N	-	3	213110-30	277408-16F	(277403-16F)	(213103-16)	277404-16F	211987A	210370 #1	211557
		4	213110-40							
		5	213110-50							
EX5104-52D/333	-	3	213111-30	277409-16F	(277403-16F)	(213117-16)	277404-16F	213872	210371 #1	-
		4	213111-40							
		5	213111-50							
EX5104-04/433	-	3	213110-30	277408-16F	(277403-16F)	(213103-16)	277404-16F	211987A	210370 #1	211557
		4	213110-40							
		5	213110-50							
EX5105-12/223N	-	3	213100-30	277407-16F	(277401-16F)	(213103-16)	277402-16F	201152E	277115 #10	-
		4	213100-40							
		5	213100-50							

形式 MACHINE TYPE /SPEC.	ゲージ		上ルーバー UPPER LOOPERS	下マス LOWER KNIFE	前 NEEDLE GUARD FRONT	後 REAR	針留 NEEDLE HOLDER	針 NEEDLE
	NG	SW						
EX5104-02/233N	-	3	277062A	213108A	213107	277061	179630-92	000642 #9
		4	277062A					
		5	277062A					
EX5104-52D/333	-	3	277062	213108	213107	277061	179630-92	000642 #9
		4	277062					
		5	277062					
EX5104-04/433	-	3	277063	213108A	213107	277061	179630-92	000629 #11
		4	277063					
		5	277063					
EX5104-04/433N	-	3	277063	213108A	213107	277061	179630-92	000629 #11
		4	277063					
		5	277063					
EX5105-12/223N	-	3	277062A	213108A	213107	277061	179630-92	000642 #9
		4	277062A					
		5	277062A					

形式 MACHINE TYPE /SPEC.	ゲージ		針板 NEEDLE PLATE	主送り歯 (組) MAIN FEED DOG ASS.	主送り歯本体 MAIN FEED DOG	補助送り歯 AUX. FEED DOG	差動送り歯 DIFF. FEED DOG	押し PRESSER FOOT	押し爪 PRESSER FOOT FINGER	補助押し UNCURLER
	NG	SW								
EX5114-92M2/223N " (EH001A 装備)	2	2	213109-20	277407-16F	(277401-16F)	(213103-16)	277402-16F	201152E	210373 # 4 210503 # 5 201155C 210503 # 5	-
		3	213109-30							
		4	213100-40							
		5	213112-30							
EX5114-03/333N	2	2	213112-40	277408-16F	(277403-16F)	(213103-16)	277404-16F	211987A	210374 # 7 210503 # 5	211557
		3	213112-50							
		4	213113-30							
		5	213113-40							
		5	213113-50							
EX5114-04/433N	2	2	213112-30	277409-16F	(277403-16F)	(213117-16)	277404-16F	211987A	210503 # 5	211557
		3	213112-40							
		4	213112-50							
		5	213113-30							
		5	213113-40							

形式 MACHINE TYPE /SPEC.	ゲージ		上ルーバー UPPER LOOPER	下ルーバー LOWER LOOPER	上メス UPPER KNIFE	下メス LOWER KNIFE	針受		針留 NEEDLE HOLDER	針 NEEDLE
	NG	SW					前 FRONT	後 REAR		
EX5114-92M2/223N " (EH001A 装備)	2	2	277062C	277060	201121A	213108	213107	277061	277022-92	000642 # 9
		3								
		4								
		5								
EX5114-03/333N	2	2	277062B	277001	201121A	213108	213107	277061	277022-92	000642 # 9
		3								
		4								
		5								
		5								
EX5114-04/433N	2	2	277063	277060	201121A	213108	213107	277061	277022-92	000629 # 11
		3								
		4								
		5								
		5								

INDEX

PART NO.	PAGE	NO. REF.	PART NO.	PAGE	NO. REF.	PART NO.	PAGE	NO. REF.	PART NO.	PAGE	NO. REF.	PART NO.	PAGE	NO. REF.
213108	50	67	240518	21	22	272584	17	32	275016A	31	9	303312A	35	33
213108	50	71	250233	3	11	272585	17	40	275017A	31	10	303313	35	34
213108	50	72	252069	19	21	272586	19	11	275017A	43	46	303448	19	14
213108	51	57	252858	19	13	272587	17	62	275018	31	6	305014	43	39
213108	51	58	270010BUD	5	33	272588	19	1	275018A	31	7	305276-91	43	12
213108	51	59	270014A	5	12	272589-92	19	2	275019A	31	30	306920	7	21
213108	51	60	270018	5	16	272590	19	5	275019B	31	31	308036	21	8
213108A	50	66	270024-9U	5	29	272591	19	7	275047	31	14	9A3002	25	14
213108A	50	68	270025	5	27	272592	17	58	275107	31	17	9A3048	3	15
213108A	50	69	270032	7	1	272593	17	60	275108	31	22	9A3067	5	35
213108A	50	70	270034	7	4	272594	17	14	275109	31	25	9A3069	5	36
213109-20	51	1	270047	3	8	272595-91	17	13	275500	33	1	9A3071	3	18
213109-30	51	2	270052	3	3	272596	17	2	275501	33	5	9A3072	5	37
213110-30	50	1	270053	3	9	272597-91	17	12	275502	33	3			
213110-30	50	8	270068	7	7	272599	17	6	275503	33	4			
213110-40	50	2	270077-UB	5	30	272600	17	9	275540	25	43			
213110-40	50	9	270144	7	14	272602	17	1	275541	25	44			
213110-40	50	10	270145	7	15	272603-92	17	21	275570	33	6			
213110-50	50	3	270148-SD	5	1	272604	17	49	275571	33	9			
213111-30	50	5	270149	5	3	272605	17	43	275572	33	7			
213111-40	50	4	270150-UD	5	7	272607	17	53	275573	33	11			
213111-40	50	6	270151	5	8	272609	17	46	275576-91	33	10			
213111-50	50	7	270152	5	19	272610	17	16	276002-UA	37	10			
213112-30	51	4	270153	5	23	272611	17	55	276003-UA	37	11			
213112-30	51	10	270154-SD	3	16	272612	17	57	276004	37	13			
213112-40	51	5	270164-9S	3	1	272613	17	7	276017	37	1			
213112-40	51	11	270166-SD	7	13	272614	19	9	277001	51	50			
213112-50	51	6	270167	7	9	272615	17	27	277022-92	51	70			
213112-50	51	12	270170-91	43	25	273000-92	21	1	277022-92	51	71			
213113-30	51	7	270171	43	26	273001-92	21	3	277022-92	51	72			
213113-40	51	8	270172	43	27	273004A	21	7	277022-92	51	73			
213113-50	51	9	270173	43	36	273006	21	15	277060	50	56			
213117-16	50	25	270174-91	43	24	273027	21	20	277060	50	57			
213117-16	50	26	270175	7	17	274000-B	23	1	277060	50	58			
213117-16	51	23	270179	7	12	274001	23	4	277060	50	59			
213264-91	21	18	270502	9	5	274002	23	5	277060	50	60			
213268	43	28	270504-UD	9	22	274003-92	23	7	277060	51	49			
213273	7	25	270505	9	21	274004	23	9	277060	51	51			
213578	25	23	270522A	9	1	274005A	23	10	277060	51	52			
213579	25	24	270522B	9	2	274006	23	11	277061	50	78			
213672	43	13	270523	9	26	274007	23	12	277061	50	79			
213672	50	35	270524	9	7	274008	23	14	277061	50	80			
213673	43	16	271000-92	11	1	274009	23	15	277061	50	81			
213674	43	18	271001	11	3	274010	23	25	277061	50	82			
213675	43	20	271001	21	5	274011-91	23	19	277061	51	66			
213679-91	43	15	271002-92	11	5	274014A	23	21	277061	51	67			
230047A	3	13	271003D	11	7	274015	23	22	277061	51	68			
240043A	5	14	271004-92	11	12	274017	23	24	277061	51	69			
240055	17	70	271005-91T	11	17	274018-92B	23	27	277062	50	52			
240094	3	6	271005B91	45	1	274019	23	29	277062A	50	51			
240097	27	10	271006-C	45	2	274020	23	32	277062A	50	55			
240097	27	16	271006-T	11	18	274033A	23	31	277062B	51	46			
240097	27	21	271007	11	19	274507A	25	29	277062C	51	45			
240097	45	20	271007	45	3	274508	25	22	277063	50	53			
240102	13	11	271008A	11	15	274513	27	9	277063	50	54			
240104	37	16	271009-92	11	24	274514	27	14	277063	51	47			
240201-92	13	13	271022A91	11	14	274514	27	19	277063	51	48			
240235-92	21	10	271500-92	13	1	274514A	45	19	277103	50	47			
240292	11	8	271500-92	15	1	274516-91	27	8	277115	43	2			
240292	17	24	271501	13	4	274517-91	27	18	277115	43	7			
240299	3	5	271501	15	4	274517A91	27	13	277115	50	46			
240301	5	18	271502-92	13	6	274517B91	45	18	277401-16F	50	23			
240303	17	65	271503-92	13	7	274520	27	2	277401-16F	51	17			
240304	37	4	271504B	15	8	274522	27	6	277402-16F	50	33			
240305	5	4	271505-92	13	16	274528A	25	10	277402-16F	51	25			
240305	5	31	271505-92	45	5	274539	25	8	277403-16F	50	19			
240305	43	38	271510D	13	28	274546-91	25	15	277403-16F	50	20			
240306	9	15	271510E	13	29	274547	25	18	277403-16F	50	21			
240310	3	20	271510M	45	16	274582	25	2	277403-16F	50	22			
240310	11	23	271510N	45	17	274583	25	7	277403-16F	51	18			
240311	15	12	271516	13	24	274584-91	27	3	277403-16F	51	19			
240312	13	12	271516A91	45	13	274585-91	27	4	277403-16F	51	20			
240325	3	7	271519	13	31	274586	25	32	277404-16F	50	29			
240326	31	28	271533-91	13	22	274587-91	25	1	277404-16F	50	30			
240328	25	36	271533A91	45	11	274588	45	23	277404-16F	50	31			
240330	9	11	271534	13	32	274589	45	22	277404-16F	50	32			
240332	19	17	271535	13	9	274590	25	40	277404-16F	51	26			
240335	9	12	271538-91	13	15	274591-91	25	39	277404-16F	51	27			
240338	15	9	271538A91	45	4	274592	27	1	277404-16F	51	28			
240339	25	6	272010-92	15	6	275000	29	13	277407-16F	50	14			
240340	9	18	272011-91	15	14	275001	29	15	277407-16F	50	18			
240404	17	67	272526	17	69	275004	31	13	277407-16F	51	13			
240454-1	17	44	272538A	19	16	275005	31	18	277408-16F	50	17			
240454-2	17	44	272539A	19	19	275006	31	20	277408-16F	51	14			
240454-3	17	44	272578	17	52	275010	31	24	277408-16F	51	16			
240484	17	18	272579	17	45	275011	31	26	277409-16F	50	15			
240503	9	9	272580	17	34	275012	31	27	277409-16F	50	16			
240504	17	47	272581-91	17	26	275013	31	4	277409-16F	51	15			
240505	17	50	272582	17	28	275013A	31	3	303026	37	14			
240517	17	17	272583	17	30	275015	31	1	303067	15	11			

www.collegesewing.co.uk

■ PEGASUS
SEWING MACHINE MFG.
CO., LTD.®

