

# EX2200

EX2200 Series

高速二重環縫いミシン

High speed double chainstitch  
machine

## Parts Catalog



**PEGASUS®**



## 目次

	頁
ベッド機構	2~3
カバー機構 (1)	4~5
カバー機構 (2)	6~7
クランクシャフト機構	8~9
糸調子機構	10~11
糸道・糸繰り	12~13
針振り機構 (1)	14~15
針振り機構 (2)	16~17
針振り機構 (3)	18~19
二重環ルーパー機構 (1)	20~21
二重環ルーパー機構 (2)	22~23
二重環ルーパー機構 (3)	24~25
送り機構 (1)	26~27
送り機構 (2)	28~29
上下メス機構	30~31
押エ機構	32~33
給油機構 (1)	34~35
給油機構 (2)	36~37
H.R.装置	38~39
糸立台	40~41
半沈床式据付付属品	42~43
専用部品	44~45
ゲージパーツ表	46
部品番号インデックス	47~48

## TABLE OF CONTENTS

	page
MACHINE BED FRAME	2~3
COVER (1)	4~5
COVER (2)	6~7
CRANKSHAFT DRIVE MECHANISM	8~9
THREAD TENSION MECHANISM	10~11
THREAD GUIDE & THREAD TAKEUP	12~13
NEEDLE DRIVE MECHANISM (1)	14~15
NEEDLE DRIVE MECHANISM (2)	16~17
NEEDLE DRIVE MECHANISM (3)	18~19
DOUBLE CHAINSTITCH LOOPER DRIVE MECHANISM (1)	20~21
DOUBLE CHAINSTITCH LOOPER DRIVE MECHANISM (2)	22~23
DOUBLE CHAINSTITCH LOOPER DRIVE MECHANISM (3)	24~25
FEED MECHANISM (1)	26~27
FEED MECHANISM (2)	28~29
KNIFE DRIVE MECHANISM	30~31
PRESSER FOOT MECHANISM	32~33
LUBRICATION MECHANISM (1)	34~35
LUBRICATION MECHANISM (2)	36~37
H.R. DEVICE	38~39
THREAD STAND	40~41
PARTS FOR SEMI-SUBMERGED INSTALLATION	42~43
SPECIFIC PARTS	44~45
GAUGE PARTS LIST	46
PART NUMBER INDEX	47~48

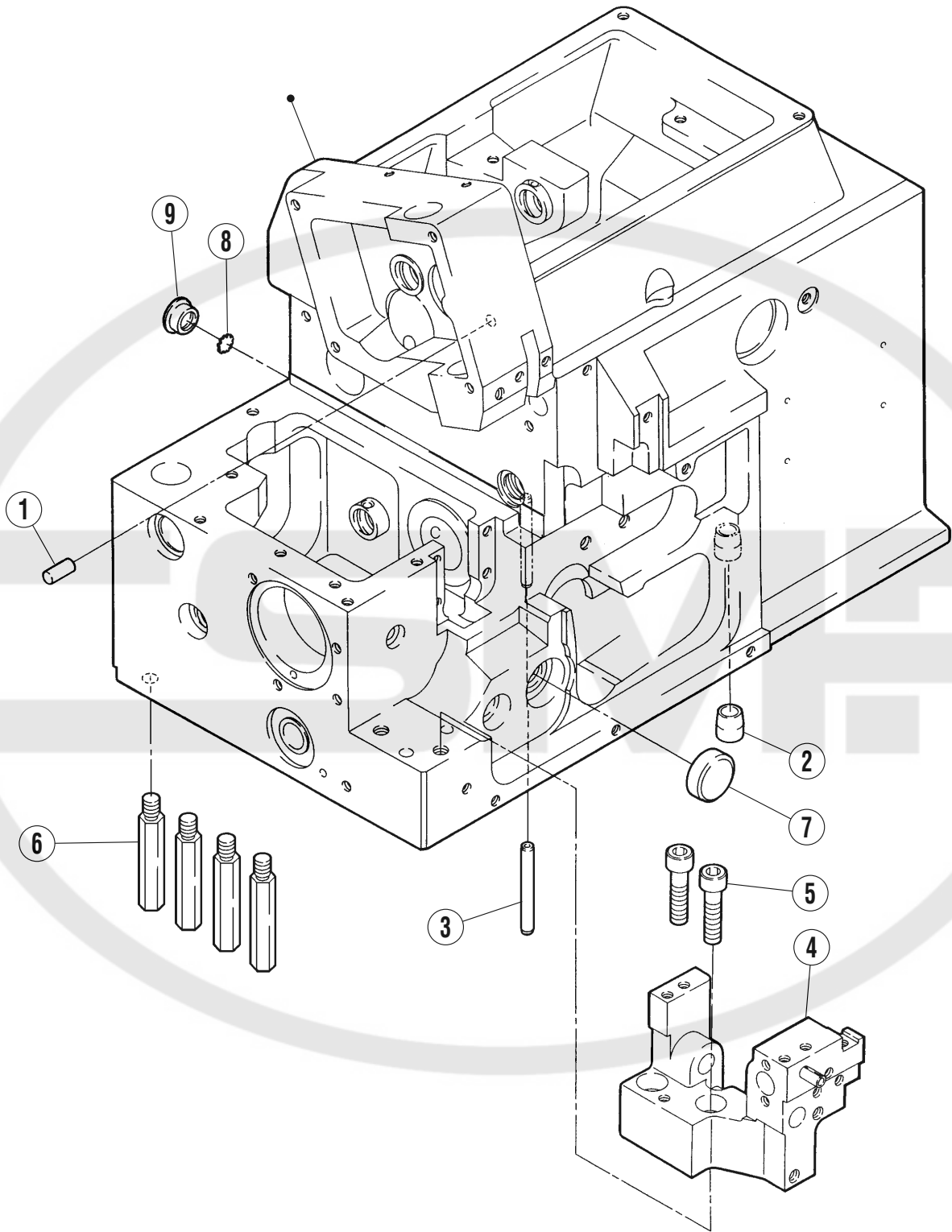

ベッド機構

MACHINE BED FRAME

REF.NO.	PART NO.	部品名称	DESCRIPTION	QT.
1	2010020	スプリングピン	SPRING PIN	1
2	2101940	案内／オイル指示	INDICATOR GUIDE	1
3	2402990	スプリングピン	SPRING PIN	1
4	270008-910	ブラケット (組)	BRACKET ASSEMBLY	1
5	0045110	六角穴ボルト/M6×25	BOLT	2
6	2700470	足ピン	BED PIN	4
7	2090840	栓	PLUG	1
8	2755410	フィルタ	FILTER	1
9	2755400	栓	PLUG	1



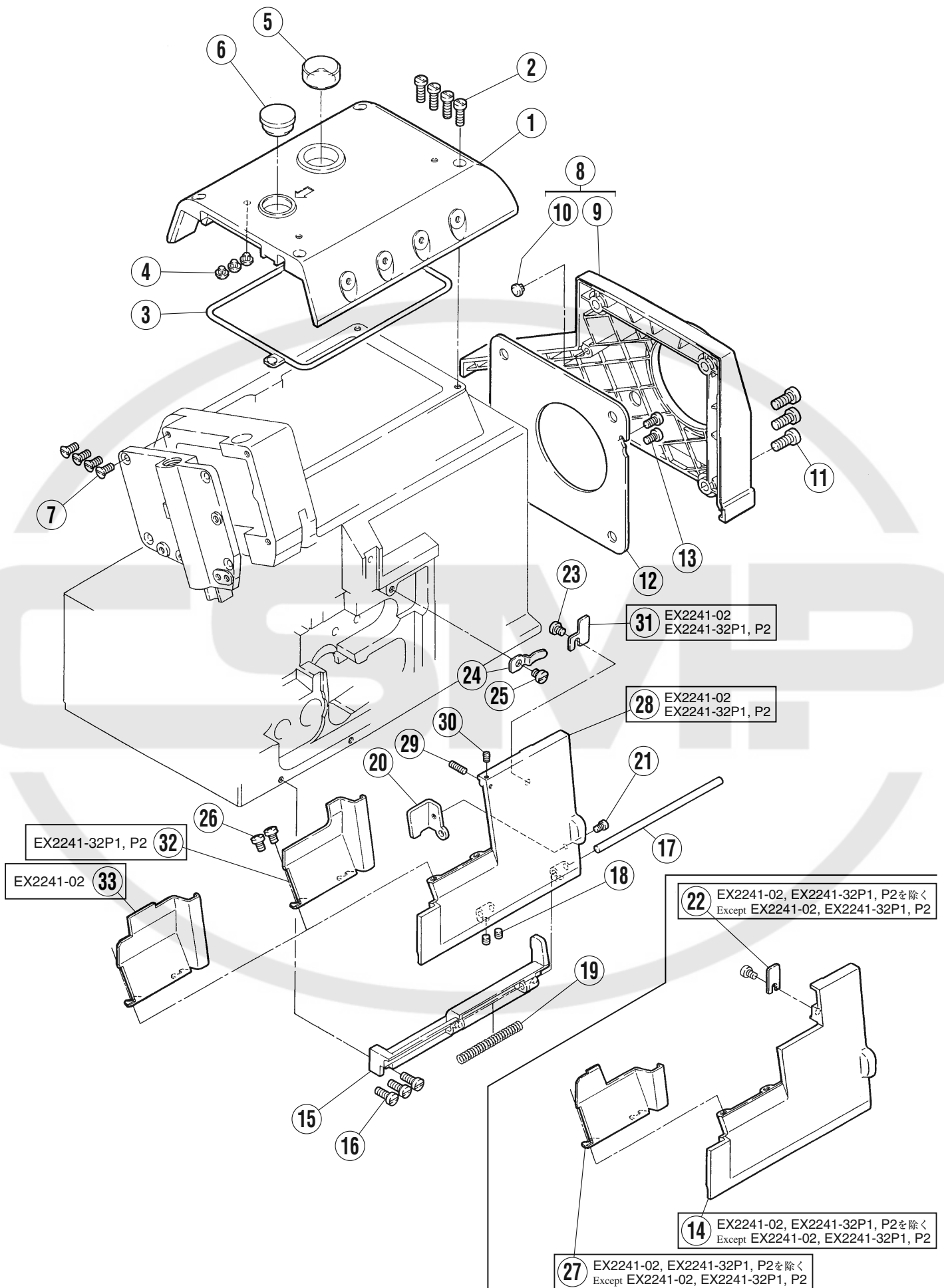

カバー機構 (1)

COVER (1)

REF.NO.	PART NO.	部品名称	DESCRIPTION	QT.
1	270020-SD0	上カバー	TOP COVER	1
2	007022A0	平ネジ/M4×14	SCREW	4
3	2700210	ガスケット	GASKET	1
4	2403050	防振ゴム	CUSHION RUBBER	3
5	179107-050	オイル窓	OIL SIGHT WINDOW	1
6	2401100	栓	PLUG	1
7	0070440	皿ネジ/M4×10	SCREW	4
8	270024-9U0	ベルトカバー (組)	BELT COVER ASSEMBLY	1
9	270077-UB0	ベルトカバー	BELT COVER	1
10	2403050	防振ゴム	CUSHION RUBBER	1
11	0071760	平ネジ/M6×14	SCREW	3
12	2700250	ファンカバー	FAN COVER	1
13	007019A0	平ネジ/M4×8	SCREW	2
14	270011AUD0	前カバー (右)	FRONT COVER (RIGHT)	1
15	2700140	ヒンジ	HINGE	1
16	007021A0	平ネジ/M4×12	SCREW	3
17	2400430	平行ピン	PIN	1
18	0045430	止ネジ/M4×4	SCREW	2
19	2403010	圧縮バネ	SPRING	1
20	2700180	ラッチ	LATCH	1
21	0070090	平ネジ/M3×5	SCREW	1
22	270152A0	ラッチ	LATCH	1
23	007017A0	平ネジ/M4×5	SCREW	1
24	2100440	板バネ	FLAT SPRING	1
25	007017A0	平ネジ/M4×5	SCREW	1
26	007018A0	平ネジ/M4×6	SCREW	2
27	270013C0	前カバー (左)	FRONT COVER (LEFT)	1
28	270011-UD0	前カバー (右)	FRONT COVER (RIGHT)	1
29	0045740	止ネジ/M3×12	SCREW	1
30	0045350	止ネジ/M3×4	SCREW	1
31	2700170	ラッチ	LATCH	1
32	270013D0	前カバー (左)	FRONT COVER (LEFT)	1
33	2700130	前カバー (左)	FRONT COVER (LEFT)	1

EX2241-32P1, P2を除く Except EX2241-32P1, P2	1
EX2241-32P1, P2	2

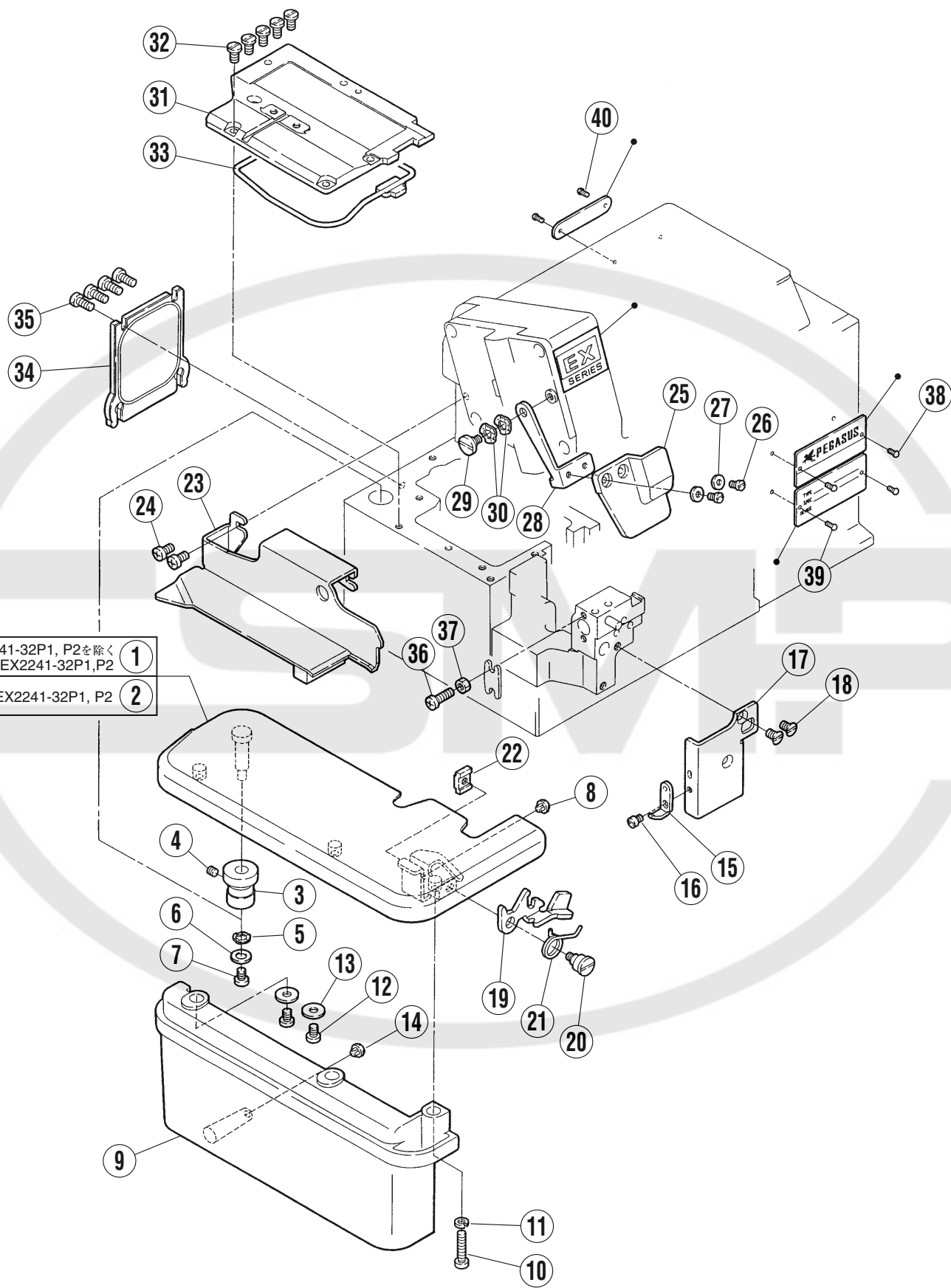



## カバ-機構 (2)

## COVER (2)

REF.NO.	PART NO.	部品名称	DESCRIPTION	QT.
1	2700350	クロスプレート (広巾)	CLOTH PLATE (WIDE)	1
2	270035F911	クロスプレート (広巾)	CLOTH PLATE (WIDE)	1
3	2700420	ブッシュ	BUSHING	1
4	0045430	止ネジ/M4×4	SCREW	1
5	2103070	波板座金	WASHER	1
6	2041150	座金	WASHER	1
7	007018A0	止ネジ/M4×6	SCREW	1
8	2403050	防振ゴム	CUSHION RUBBER	1
9	270030-UB0	横カバー (広巾)	SIDE COVER (WIDE)	1
10	007025A0	平ネジ/M4×20	SCREW	1
11	2012520	バネ座金	SPRING WASHER	1
12	007018A0	平ネジ/M4×6	SCREW	2
13	2403430	座金	WASHER	2
14	2403050	防振ゴム	CUSHION RUBBER	1
15	2700490	ラッチ	LATCH	1
16	0071800	平ネジ/M3.5×4.5	SCREW	1
17	2700150	当板	PLATE	1
18	0070770	皿ネジ/M4×7	SCREW	2
19	2700430	レバー	LEVER	1
20	0071720	段付ネジ/M4	SCREW	1
21	2700440	ネジリバネ	SPRING	1
22	2700450	ブラケット	BRACKET	1
23	2700190	布案内	FABRIC GUARD	1
24	007019A0	平ネジ/M4×8	SCREW	2
25	2700330	アイガード	EYE GUARD	1
26	0070620	平ネジ/M3×6	SCREW	2
27	2028750	座金	WASHER	2
28	2700340	ブラケット	BRACKET	1
29	0070660	段付ネジ/M4	SCREW	1
30	2103070	波板座金	WASHER	2
31	2701770	上蓋	BED COVER PLATE	1
32	0070840	六角ボルト/M4×8	BOLT	5
33	2700230	ガスケット	GASKET	1
34	2700260	後蓋	COVER PLATE	1
35	0070200	平ネジ/M4×10	SCREW	4
36	007023A0	平ネジ/M4×16	SCREW	1
37	0048210	六角ナット/M4	NUT	1
38	2106790	ピン	PIN	2
39	2106790	ピン	PIN	2
40	2106790	ピン	PIN	2

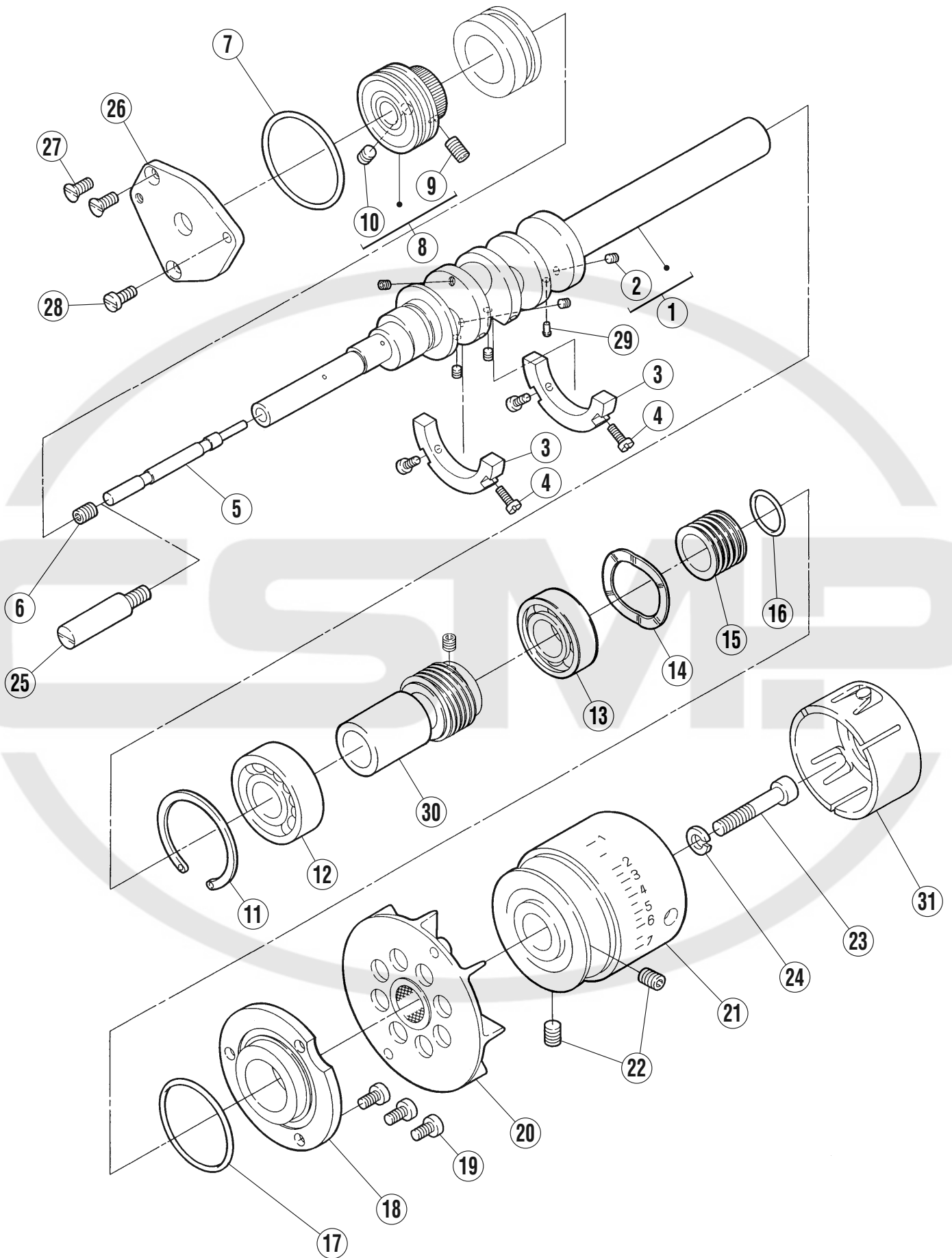

## クランクシャフト機構

## CRANKSHAFT DRIVE MECHANISM

REF.NO.	PART NO.	部品名称	DESCRIPTION	QT.
1	270500A0	クランク軸	CRANKSHAFT	1
2	0071510	止ネジ/M3.5×3	SCREW	5
3	2705020	バランスウエイト	BALANCE WEIGHT	2
4	0070110	平ネジ/M3×8	SCREW	4
5	2705030	段付ピン	PIN	1
6	0045410	止ネジ/M6×8	SCREW	1
7	2403400	Oリング	O RING	1
8	270507-910	ボールベアリング (組)	BALL BEARING ASSEMBLY	1
9	0045720	止ネジ/M5×10	SCREW	1
10	0045140	止ネジ/M5×5	SCREW	1
11	2403350	止メ輪	RING	1
12	2129870	ボールベアリング	BALL BEARING	1
13	2115260	ボールベアリング	BALL BEARING	1
14	2403060	波板座金	WASHER	1
15	2100560	油切り	OIL SEAL	1
16	2100570	Oリング	O RING	1
17	2403400	Oリング	O RING	1
18	2115280	ハウジング	HOUSING	1
19	007020A0	平ネジ/M4×10	SCREW	3
20	2705050	ファン (組)	FAN ASSEMBLY	1
21	270504-UD0	プーリー	MACHINE PULLEY	1
22	0045410	止ネジ/M6×8	SCREW	2
23	0045230	六角穴ボルト/M6×35	BOLT	1
24	2042930	バネ座金	SPRING WASHER	1
25	2705100	段付ピン	PIN	1
26	2705090	蓋	COVER	1
27	0070440	皿ネジ/M4×10	SCREW	2
28	0070200	平ネジ/M4×10	SCREW	1
29	2086270	油栓	PLUG	1
30	270523A0	スペーサー	SPACER	1
31	2705260	プーリー蓋	PULLEY COVER	1

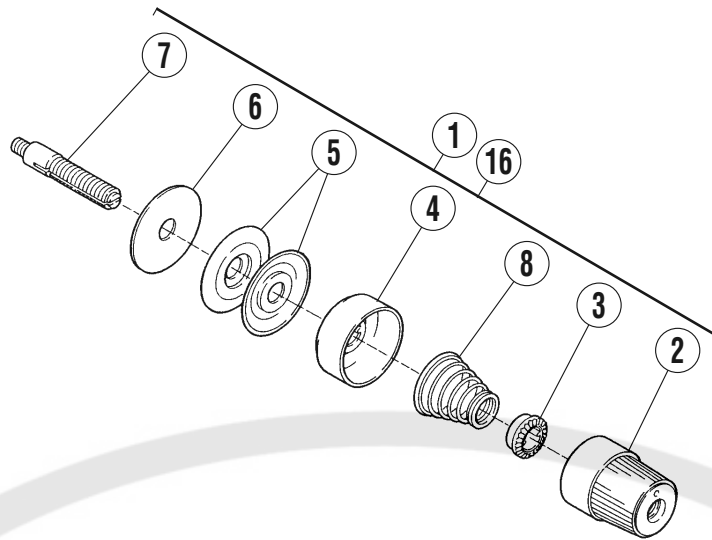

EX2241

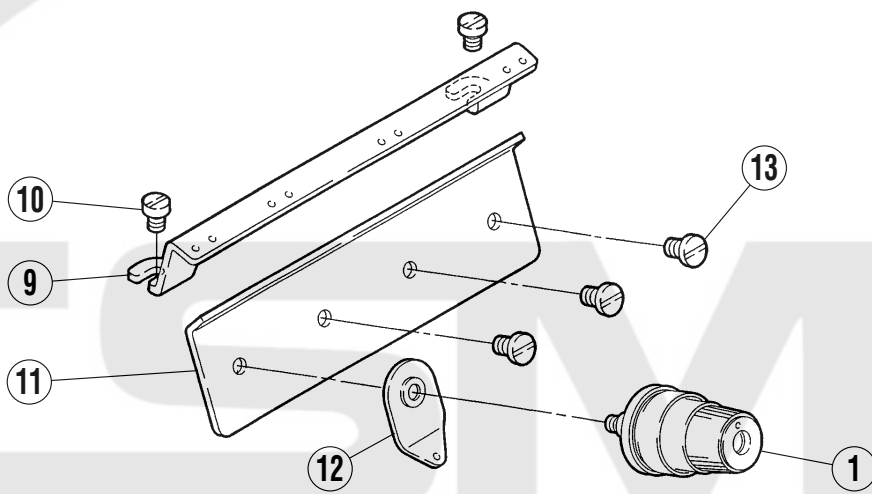

EX2242

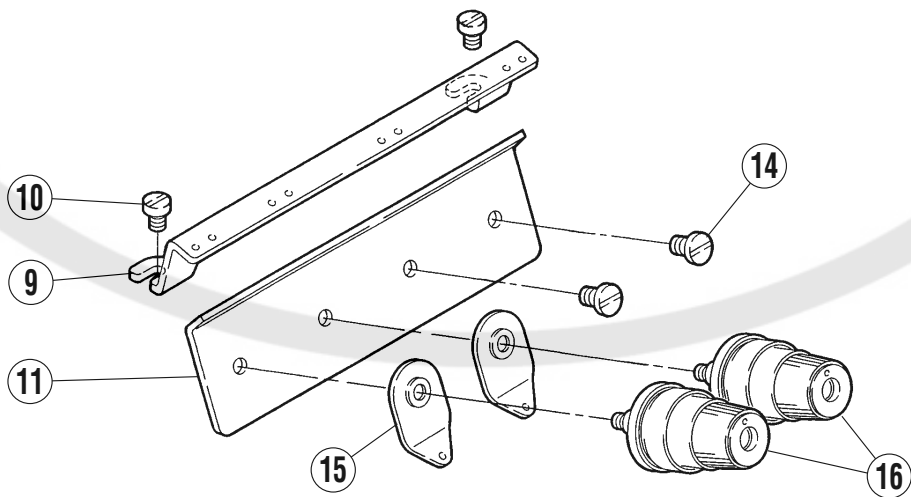

## 糸調子機構

## THREAD TENSION MECHANISM

REF.NO.	PART NO.	部品名称	DESCRIPTION	QT.
1	210529-9T0	糸調子 (組)	TENSION SPRING ASSEMBLY	1
2	263543-TA	調子ナット	NUT	1
3	2084480	ラチェット	RATCHET	1
4	263544-TA	受皿	CUP	1
5	2103190	調子皿	TENSION DISC	2
6	2084490	フェルト	FELT	1
7	005082A0	調子棒/C5	SCREW STUD	1
8	2010370	圧縮バネ (強)	SPRING (HEAVY)	1
9	2750000	糸道	THREAD GUIDE	1
10	007018A0	平ネジ/M4×6	SCREW	2
11	2750010	糸道	THREAD GUIDE	1
12	2028490	調子台	TENSION GUIDE	1
13	004009-1HC0	平ネジ/C5×7.5	SCREW	3
14	004009-1HC0	平ネジ/C5×7.5	SCREW	2
15	2028490	調子台	TENSION GUIDE	2
16	210529-9T0	糸調子 (組)	TENSION SPRING ASSEMBLY	2



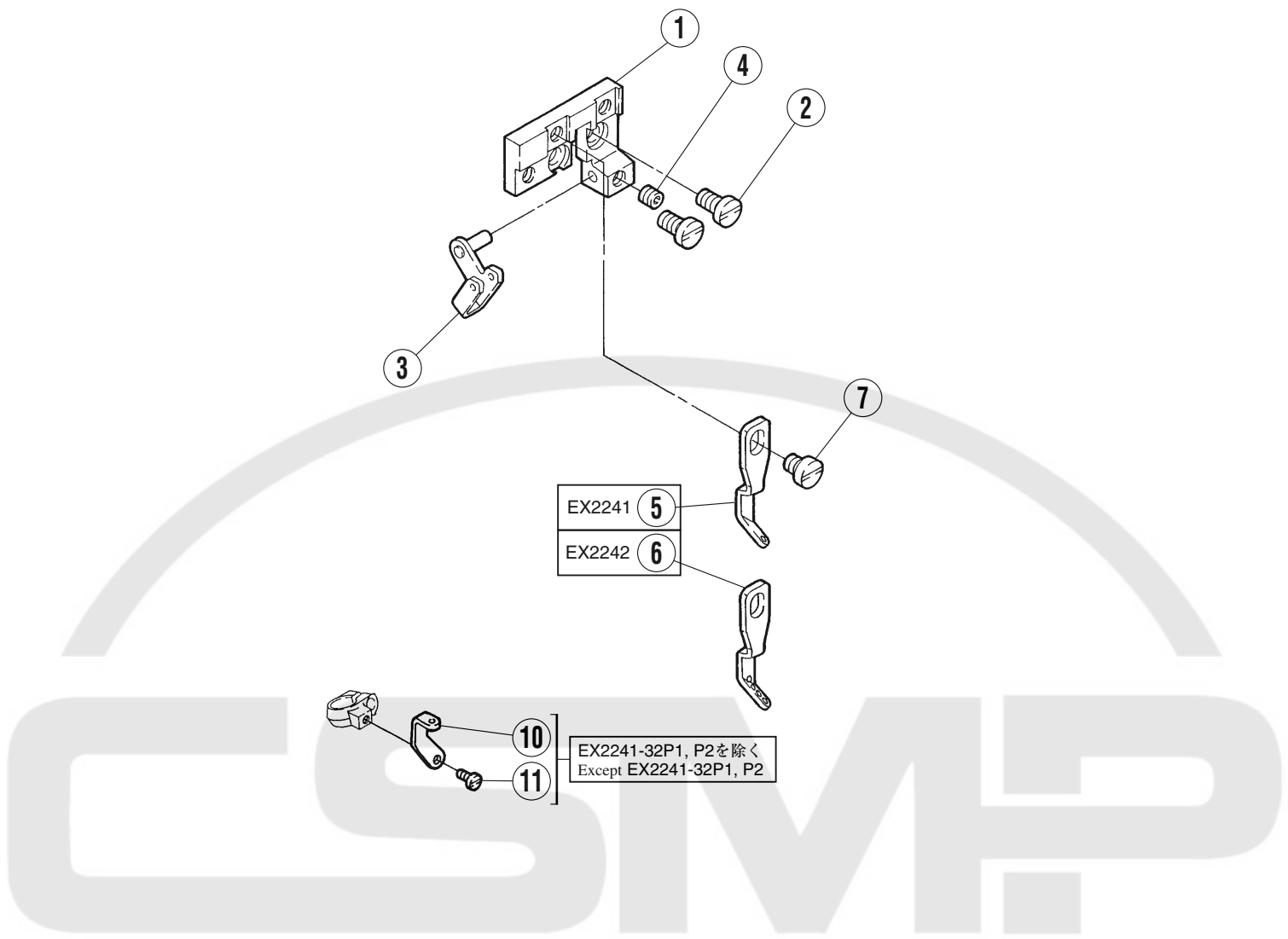

EX2241 5  
EX2242 6

EX2241-32P1, P2を除く  
Except EX2241-32P1, P2

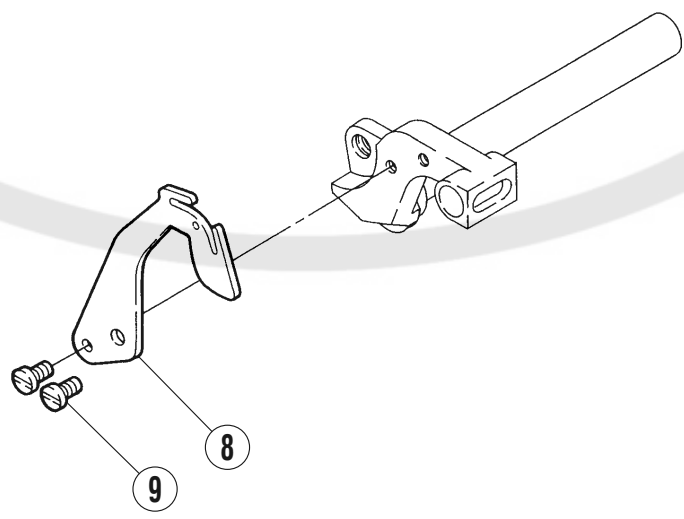

## 糸道・糸繰り

## THREAD GUIDE &amp; THREAD TAKEUP

REF.NO.	PART NO.	部品名称	DESCRIPTION	QT.
1	2750210	ブラケット	BRACKET	1
2	0070820	平ネジ/M4×8	SCREW	2
3	2750220	糸道	THREAD GUIDE	1
4	0045430	止ネジ/M4×4	SCREW	1
5	2750280	糸道	THREAD GUIDE	1
6	275028A0	糸道	THREAD GUIDE	1
7	0070170	平ネジ/M4×5	SCREW	1
8	2750270	針糸繰り	THREAD TAKE-UP	1
9	0070620	平ネジ/M3×6	SCREW	2
10	2750650	糸道	THREAD GUIDE	1
11	0071200	平ネジ/M2×3	SCREW	1



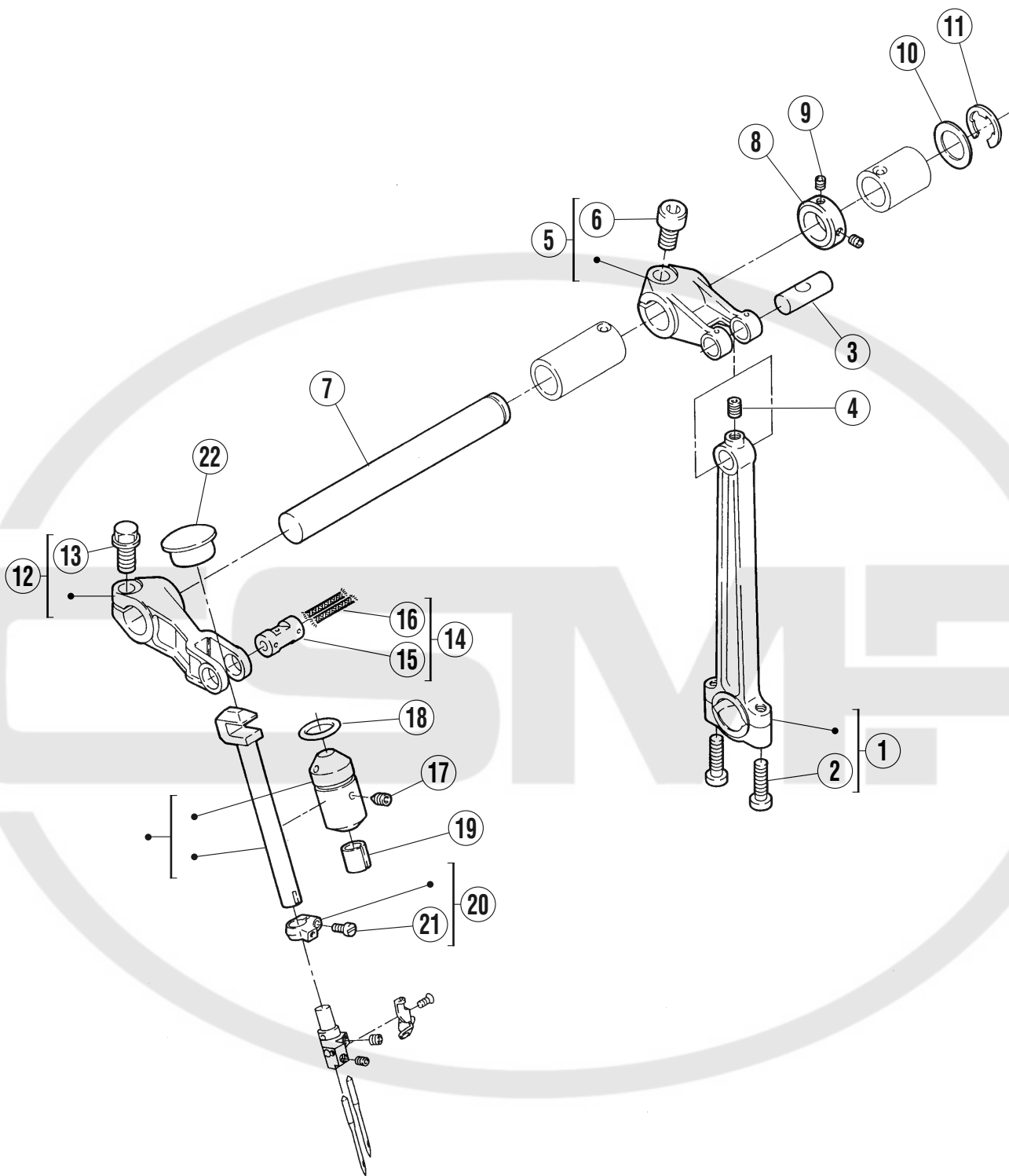



## 針振り機構 (1)

## NEEDLE DRIVE MECHANISM (1)

REF.NO.	PART NO.	部品名称	DESCRIPTION	QT.
1	271000-920	ロッド (組)	CONNECTION ASSEMBLY	1
2	007023A0	平ネジ/M4×16	SCREW	2
3	2710010	ピン	PIN	1
4	0045380	止ネジ/M4×6	SCREW	1
5	271002-920	クランク (組)	CRANK ASSEMBLY	1
6	0045330	六角穴ボルト/M6×12	BOLT	1
7	2710030	軸	SHAFT	1
8	2403080	カラー	COLLAR	1
9	0045430	止ネジ/M4×4	SCREW	2
10	2082350	座金	WASHER	1
11	2025770	止メ輪	RING	1
12	271004-920	レバー	LEVER	1
13	0071500	六角ボルト/M6×12	BOLT	1
14	271022A910	軸 (組)	SHAFT ASSEMBLY	1
15	271008A0	軸	SHAFT	1
16	2021770	給油紐	OIL STRING	2
17	0045460	止ネジ/M4×5	SCREW	1
18	2010220	Oリング	O RING	1
19	179009-050	フェルト	FELT	1
20	271009-920	リング	RING	1
21	0070350	平ネジ/M3×6	SCREW	1
22	2403100	栓	PLUG	1

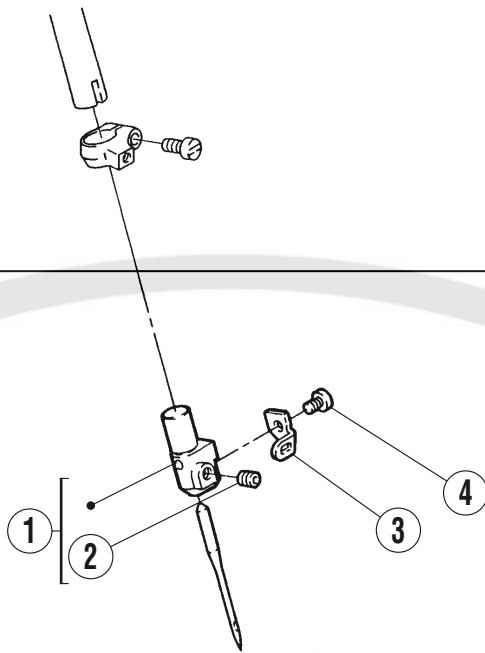

■ 1本針 (1-needle)  
EX2241-42P2, 52P2

■ 2本針 (2-needle)  
EX2242-52P2

EX2241-32P1, P2  
EX2241-02

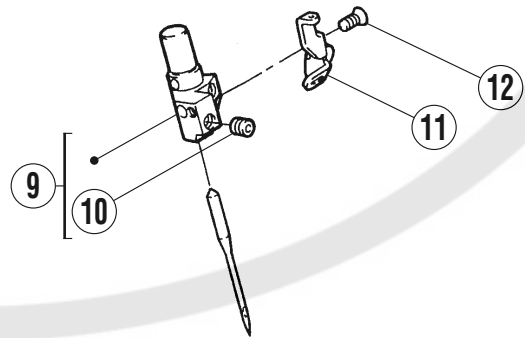
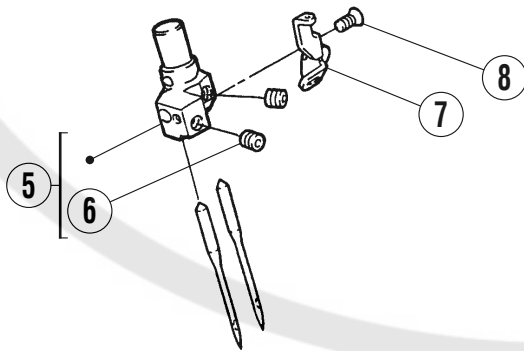

## 針振り機構 (2)

## NEEDLE DRIVE MECHANISM (2)

REF.NO.	PART NO.	部品名称	DESCRIPTION	QT.
1	XXXXXX	針留 (組)	NEEDLE HOLDER ASSEMBLY	1
2	0045540	止ネジ/M3×3	SCREW	1
3	275019A0	糸道	THREAD GUIDE	1
4	0071200	平ネジ/M2×3	SCREW	1
5	XXXXXX	針留	NEEDLE HOLDER	1
6	0045540	止ネジ/M3×3	SCREW	2
7	2750300	糸道	THREAD GUIDE	1
8	0071190	皿ネジ/M2×5	SCREW	1
9	XXXXXX	針留	NEEDLE HOLDER	1
10	0045540	止ネジ/M3×3	SCREW	1
11	2750300	糸道	THREAD GUIDE	1
12	0071190	皿ネジ/M2×5	SCREW	1



●XXXXXXはゲージパーツです。  
部品番号は、46頁のゲージパーツ表で確認してください。

●"XXXXXX" represents the gauge part.  
Please refer to the gauge part list on page 46.

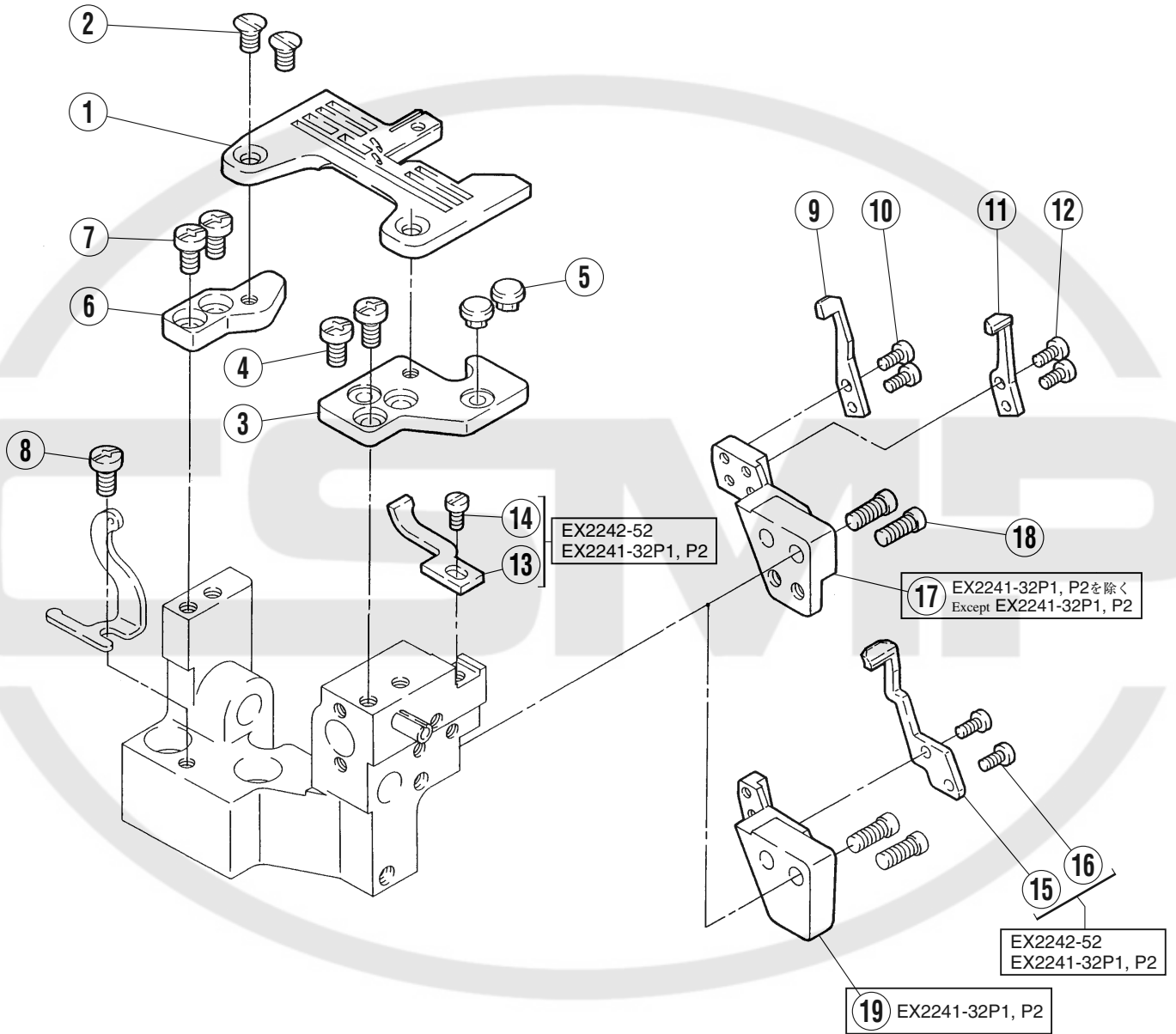

## 針振り機構 (3)

## NEEDLE DRIVE MECHANISM (3)

REF.NO.	PART NO.	部品名称	DESCRIPTION	QT.
1	XXXXXX	針板	NEEDLE PLATE	1
2	0071700	平ネジ/M4×7.5	SCREW	2
3	2710100	取付板 (前)	BRACKET (FRONT)	1
4	007019A0	平ネジ/M4×8	SCREW	2
5	2403050	防振ゴム	CUSHION RUBBER	2
6	2710110	取付板 (後)	BRACKET (REAR)	1
7	007019A0	平ネジ/M4×8	SCREW	2
8	007019A0	平ネジ/M4×8	SCREW	1
9	XXXXXX	針受 (前)	NEEDLE GUARD (FRONT)	1
10	0070100	平ネジ/M3×6	SCREW	2
11	XXXXXX	針受 (後)	NEEDLE GUARD (REAR)	1
12	0070100	平ネジ/M3×6	SCREW	2
13	XXXXXX	針受 (前)	NEEDLE GUARD (FRONT)	1
14	0070190	平ネジ/M4×8	SCREW	1
15	XXXXXX	針受 (後)	NEEDLE GUARD (REAR)	1
16	0070100	平ネジ/M3×6	SCREW	2
17	2710240	ブラケット	BRACKET	1
18	0071140	平ネジ/M4×10	SCREW	2
19	271013A0	ブラケット	BRACKET	1

●XXXXXXはゲージパーツです。  
部品番号は、46頁のゲージパーツ表で確認してください。

●"XXXXXX" represents the gauge part.  
Please refer to the gauge part list on page 46.

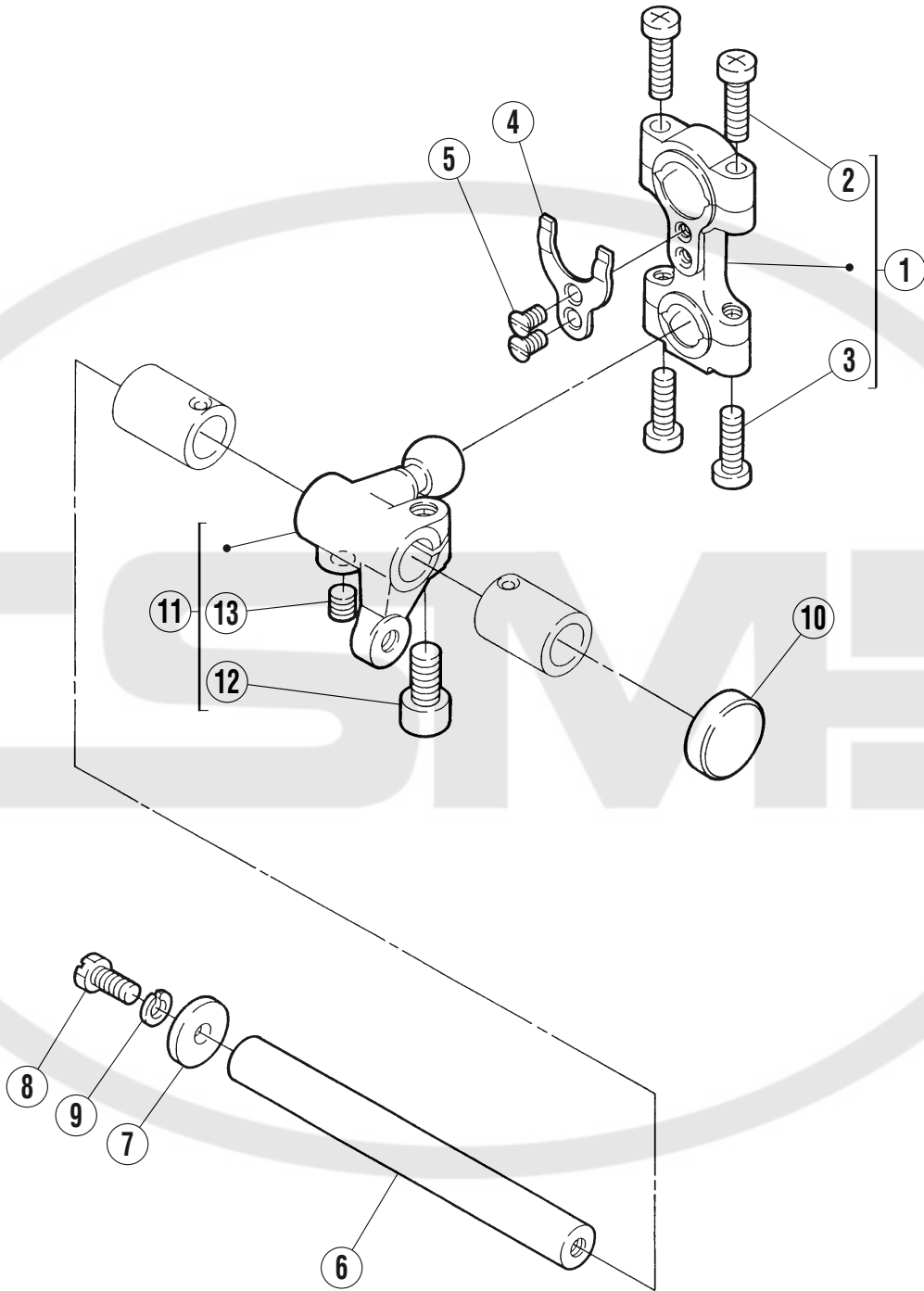

二重環ルーパー機構 (1)

DOUBLE CHAINSTITCH LOOPER DRIVE MECHANISM (1)

REF.NO.	PART NO.	部品名称	DESCRIPTION	QT.
1	271500-920	ロッド	CONNECTION	1
2	007023A0	平ネジ/M4×16	SCREW	2
3	007022A0	平ネジ/M4×14	SCREW	2
4	2715010	振れ止め	GUIDE	1
5	0070410	皿ネジ/M3×6	SCREW	2
6	271504A0	軸	SHAFT	1
7	2403380	座金	WASHER	1
8	0071740	六角ネジ/M5×10	SCREW	1
9	3030670	バネ座金	SPRING WASHER	1
10	2090840	蓋	COVER	1
11	273511-920	クランク	CRANK	1
12	0045330	六角穴ボルト/M6×12	BOLT	1
13	0045140	止ネジ/M5×5	SCREW	1



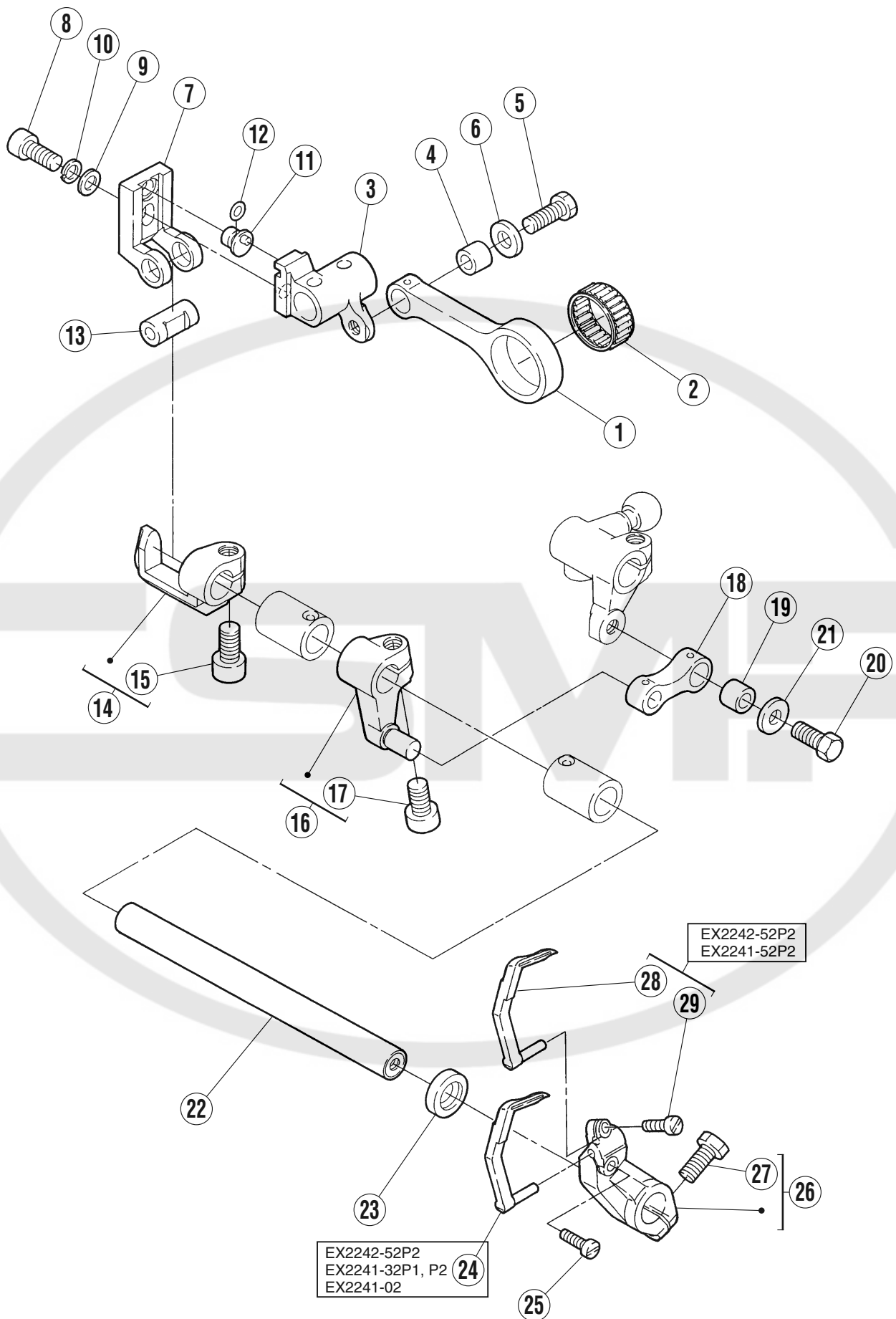



## 二重環ルーパー機構 (2)

## DOUBLE CHAINSTITCH LOOPER DRIVE MECHANISM (2)

REF.NO.	PART NO.	部品名称	DESCRIPTION	QT.
1	2735000	ロッド	CONNECTION	1
2	205015-20	ニードルベアリング	NEEDLE BEARING	1
3	2735010	クランク	CRANK	1
4	2405420	ブッシュ	BUSHING	1
5	0070560	六角ネジ/M5×13	SCREW	1
6	2400390	座金	WASHER	1
7	2735020	スライダー	SLIDER	1
8	0045310	六角穴ボルト/M5×12	BOLT	1
9	2400620	座金	WASHER	1
10	3030670	バネ座金	SPRING WASHER	1
11	2525150	段付ピン	PIN	1
12	2089490	Oリング	O RING	1
13	2735040	軸	SHAFT	1
14	273505-920	ホルダー	HOLDER	1
15	0045330	六角穴ボルト/M6×12	BOLT	1
16	273509-920	クランク	CRANK	1
17	0045330	六角穴ボルト/M6×12	BOLT	1
18	2725170	リンク	LINK	1
19	2405420	ブッシュ	BUSHING	1
20	0070560	六角ネジ/M5×13	SCREW	1
21	2400390	座金	WASHER	1
22	2735060	軸	SHAFT	1
23	204052A0	オイルシール	OIL SEAL	1
24	XXXXXX	二重環ルーパー	DOUBLE CHAINSTITCH LOOPER	1
25	0070140	止ネジ/M3.5×10	SCREW	1
26	273513-920	ルーパー台	LOOPER HOLDER	1
27	0070550	六角ネジ/M5×13	SCREW	1
28	XXXXXX	二重環ルーパー	DOUBLE CHAINSTITCH LOOPER	1
29	0070130	平ネジ/M3.5×8	SCREW	1

●XXXXXXXはゲージパーツです。  
部品番号は、46頁のゲージパーツ表で確認してください。

●"XXXXXXX" represents the gauge part.  
Please refer to the gauge part list on page 46.

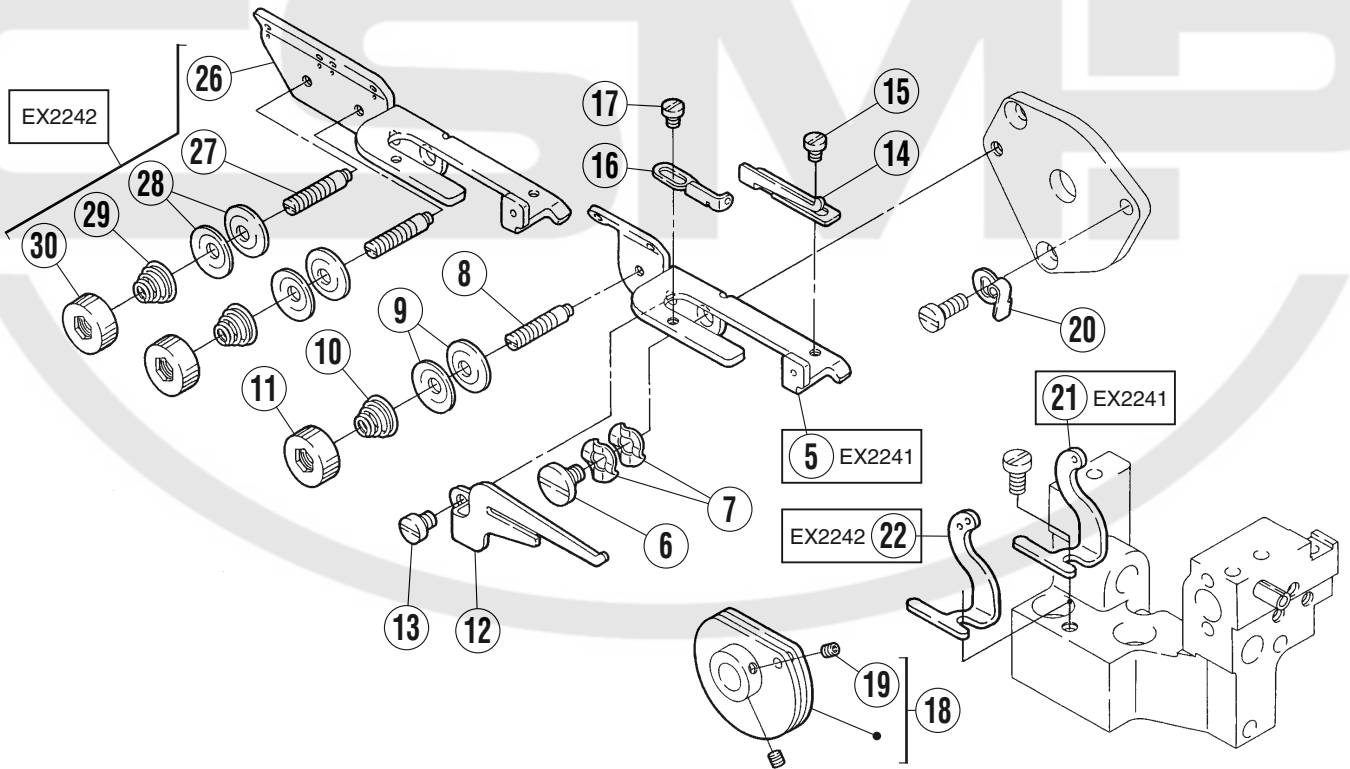
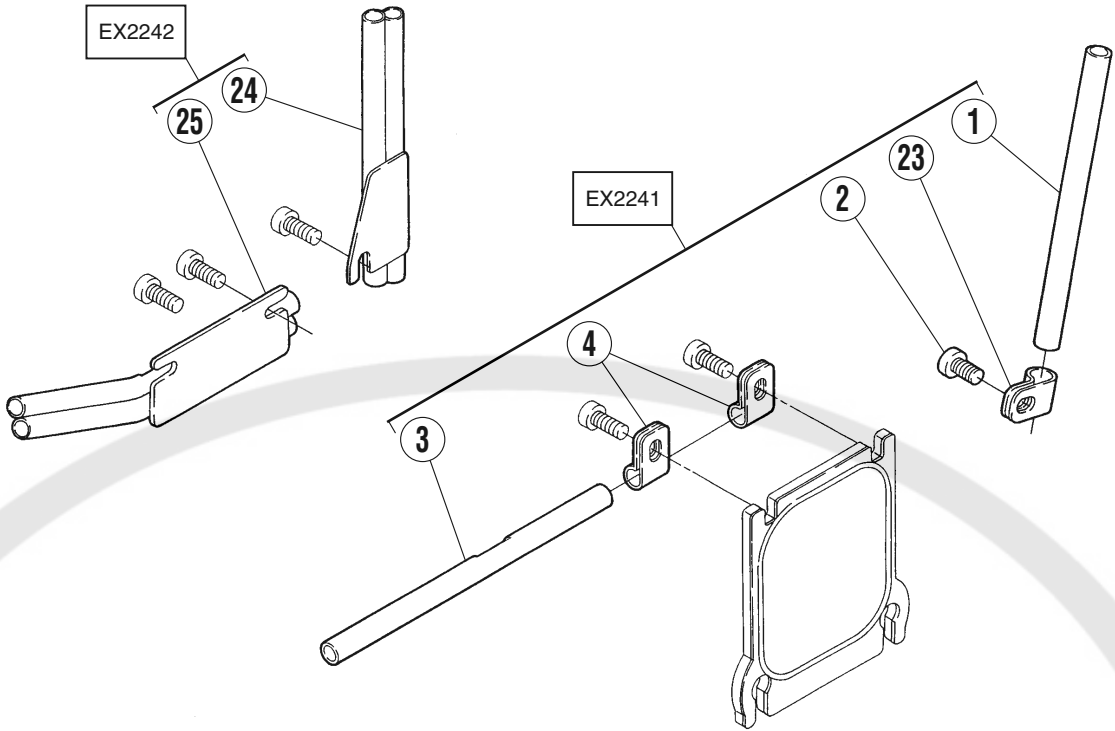

二重環ルーパー機構 (3)

DOUBLE CHAINSTITCH LOOPER DRIVE MECHANISM (3)

REF.NO.	PART NO.	部品名称	DESCRIPTION	QT.
1	1921200	糸道パイプ	THREAD GUIDE PIPE	1
2	007019A0	平ネジ/M4×8	SCREW	1
3	2750320	糸道パイプ	THREAD GUIDE PIPE	1
4	2061150	ブラケット	BRACKET	2
5	2750330	ブラケット	BRACKET	1
6	0070660	段付ネジ/M4	SCREW	1
7	2103070	波板座金	WASHER	2
8	0071671	段付ネジ/M3	SCREW	1
9	1371080	調子皿	TENSION DISC	2
10	2113880	圧縮バネ	SPRING	1
11	2750340	ツマミ	KNOB	1
12	2750350	糸受	THREAD GUIDE	1
13	0070170	平ネジ/M4×5	SCREW	1
14	2750360	糸道	THREAD GUIDE	1
15	0070080	平ネジ/M3×4	SCREW	1
16	2750390	糸道	THREAD GUIDE	1
17	0070080	平ネジ/M3×4	SCREW	1
18	179498-920	ルーパー糸繰り (組)	LOOPER THREAD TAKE-UP ASSEMBLY	1
19	0045540	止ネジ/M3×3	SCREW	2
20	2750370	板バネ	FLAT SPRING	1
21	2750380	糸道	THREAD GUIDE	1
22	275038A0	糸道	THREAD GUIDE	1
23	2061150	ブラケット	BRACKET	1
24	275066-910	糸道パイプ (組)	THREAD PIPE ASSEMBLY	1
25	275061-910	糸道パイプ (組)	THREAD PIPE ASSEMBLY	1
26	2750640	ブラケット	BRACKET	1
27	0071671	段付ネジ/M3	SCREW	2
28	1371080	調子皿	TENSION DISC	4
29	2113880	圧縮バネ	SPRING	2
30	2750340	ツマミ	KNOB	2

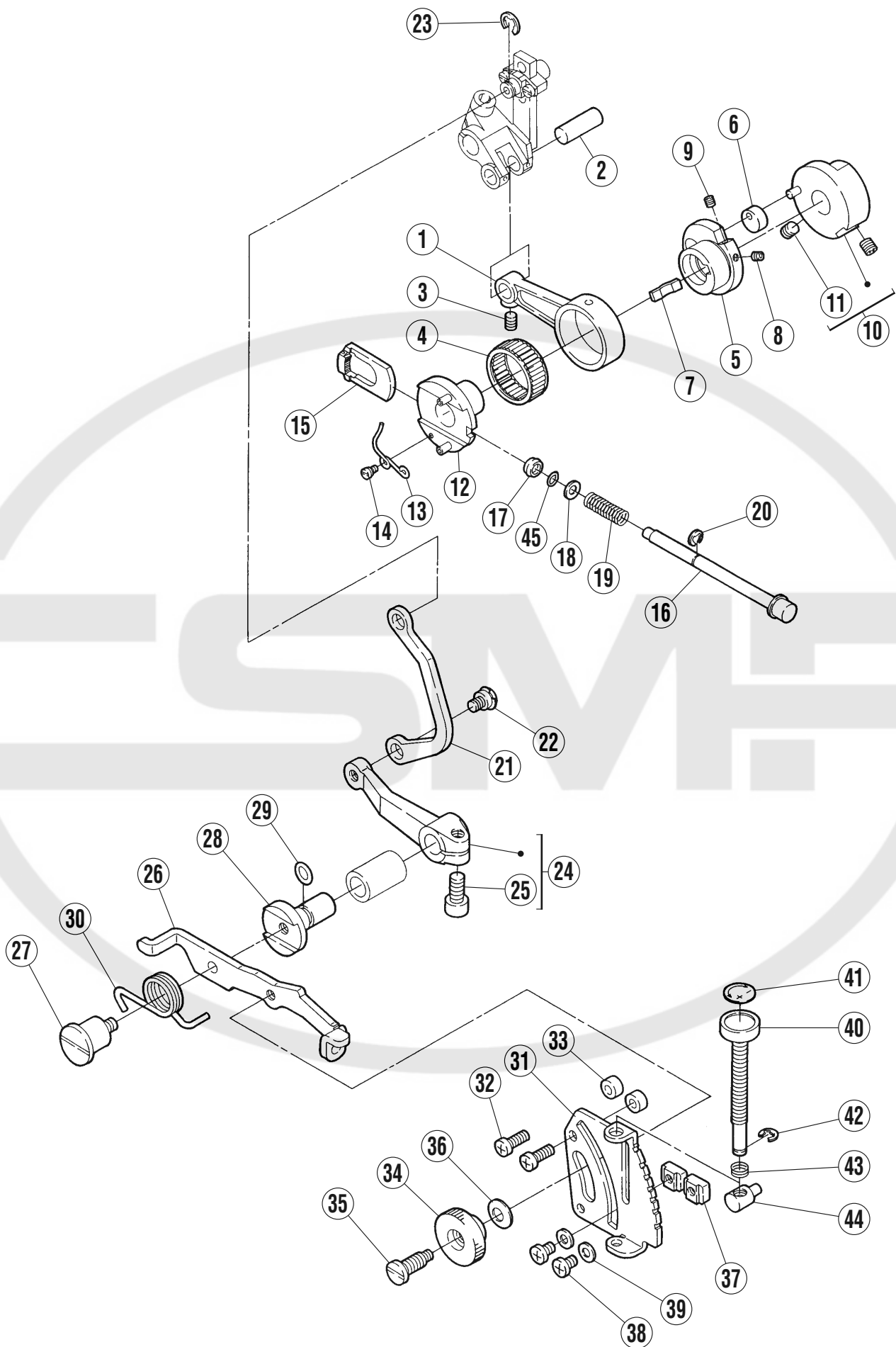

## 送り機構 (1)

## FEED MECHANISM (1)

REF.NO.	PART NO.	部品名称	DESCRIPTION	QT.
1	2725000	ロッド	CONNECTION	1
2	2710010	ピン	PIN	1
3	0045380	止ネジ/M4×6	SCREW	1
4	240012-20	ニードルベアリング	NEEDLE BEARING	1
5	2725010	エキセン	ECCENTRIC	1
6	2101290	案内/送りエキセン	GUIDE (FEED ECCENTRIC)	1
7	2101300	板バネ	FLAT SPRING	1
8	0045350	止ネジ/M3×4	SCREW	1
9	0045350	止ネジ/M3×4	SCREW	1
10	272506-910	調節台	REGULATOR	1
11	0045140	止ネジ/M5×5	SCREW	2
12	272504-910	エキセン (組)	ECCENTRIC ASSEMBLY	1
13	2725030	ネジリバネ	SPRING	1
14	0070380	段付ネジ/M2	SCREW	1
15	2725020	ラチェット	RATCHET	1
16	2725090	プッシュボタン	PUSH BUTTON	1
17	2403150	ガスケット	GASKET	1
18	2403140	座金	WASHER	1
19	2403170	圧縮バネ	SPRING	1
20	2005550	止メ輪	RING	1
21	2725290	リンク	LINK	1
22	0070580	段付ネジ/M5	SCREW	1
23	2025220	止メ輪	RING	1
24	272530A920	レバー	LEVER	1
25	0045330	六角穴ボルト/M6×12	BOLT	1
26	2725320	レバー	LEVER	1
27	0071610	段付ネジ/M5	SCREW	1
28	272533A1	軸	SHAFT	1
29	2041850	Oリング	O RING	1
30	2725340	ネジリバネ	SPRING	1
31	2725350	調節板	REGULATOR PLATE	1
32	007021A0	平ネジ/M4×12	SCREW	2
33	2403210	スペーサー	SPACER	2
34	2520690	ナット	NUT	1
35	0070590	段付ネジ/M4.5	SCREW	1
36	2113010	バネ座金	SPRING WASHER	1
37	2526580	ストッパー	STOPPER	2
38	007018A0	平ネジ/M4×6	SCREW	2
39	3034480	座金	WASHER	2
40	272538A0	調節棒	ADJUSTING BAR	1
41	2403220	シール	SEAL	1
42	2005550	止メ輪	RING	1
43	2405590	圧縮バネ	SPRING	1
44	272539A0	段付ピン	PIN	1
45	2063660	Oリング	O RING	1

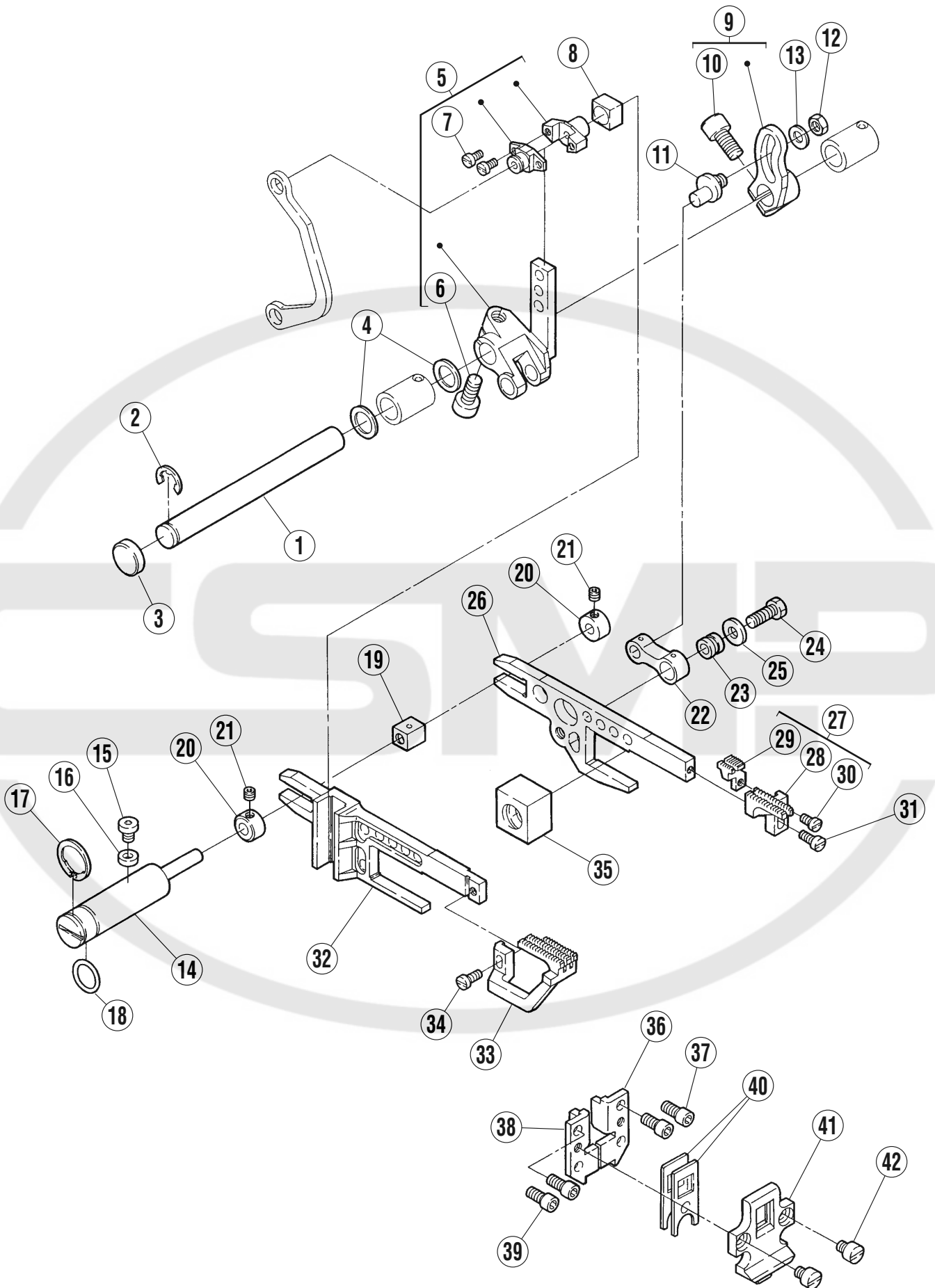

## 送り機構 (2)

## FEED MECHANISM (2)

REF.NO.	PART NO.	部品名称	DESCRIPTION	QT.
1	2725160	軸	SHAFT	1
2	2050610	止メ輪	RING	1
3	2081731	栓	PLUG	1
4	2403110	座金	WASHER	2
5	272510-910	クランク	CRANK	1
6	0045330	六角穴ボルト/M6×12	BOLT	1
7	0070100	平ネジ/M3×6	SCREW	2
8	2725180	角駒	BLOCK	1
9	272514-921	クランク	CRANK	1
10	0045330	六角穴ボルト/M6×12	BOLT	1
11	2725151	ピン	PIN	1
12	0048050	六角ナット/M5	NUT	1
13	2400620	座金	WASHER	1
14	2725250	段付ピン	PIN	1
15	0072380	六角穴ボルト/M4×6	BOLT	1
16	2403180	ガスケット	GASKET	1
17	2403190	止メ輪	RING	1
18	2010220	Oリング	O RING	1
19	2725260	角駒	BLOCK	1
20	2403030	カラー	COLLAR	2
21	0045430	止ネジ/M4×4	SCREW	2
22	2725170	リンク	LINK	1
23	2405420	ブッシュ	BUSHING	1
24	0070560	六角ネジ/M5×13	SCREW	1
25	2400390	座金	WASHER	1
26	2725270	主送り台	MAIN FEED BAR	1
27	XXXXXX	主送り歯 (組)	MAIN FEED DOG ASSEMBLY	1
28	XXXXXX	主送り歯	MAIN FEED DOG	1
29	XXXXXX	補助送り歯	AUXILIARY FEED DOG	1
30	0070100	平ネジ/M3×6	SCREW	1
31	0070130	平ネジ/M3.5×8	SCREW	1
32	2725280	差動送り台	DIFFERENTIAL FEED BAR	1
33	XXXXXX	差動送り歯	DIFFERENTIAL FEED DOG	1
34	0070130	平ネジ/M3.5×8	SCREW	1
35	2725240	角駒	BLOCK	1
36	2725190	送り台案内 (右)	FEED BAR GUIDE (RIGHT)	1
37	0071100	六角穴ボルト/M4×9	BOLT	2
38	2725200	送り台案内 (左)	FEED BAR GUIDE (LEFT)	1
39	0071100	六角穴ボルト/M4×9	BOLT	2
40	2725210	油切り	OIL SEAL	2
41	2726170	油切り案内	GUIDE (FEED BAR OIL SEAL)	1
42	0045730	平ネジ/M4×5	SCREW	2

●XXXXXXXはゲージパーツです。  
部品番号は、46頁のゲージパーツ表で確認してください。

●"XXXXXXX" represents the gauge part.  
Please refer to the gauge part list on page 46.

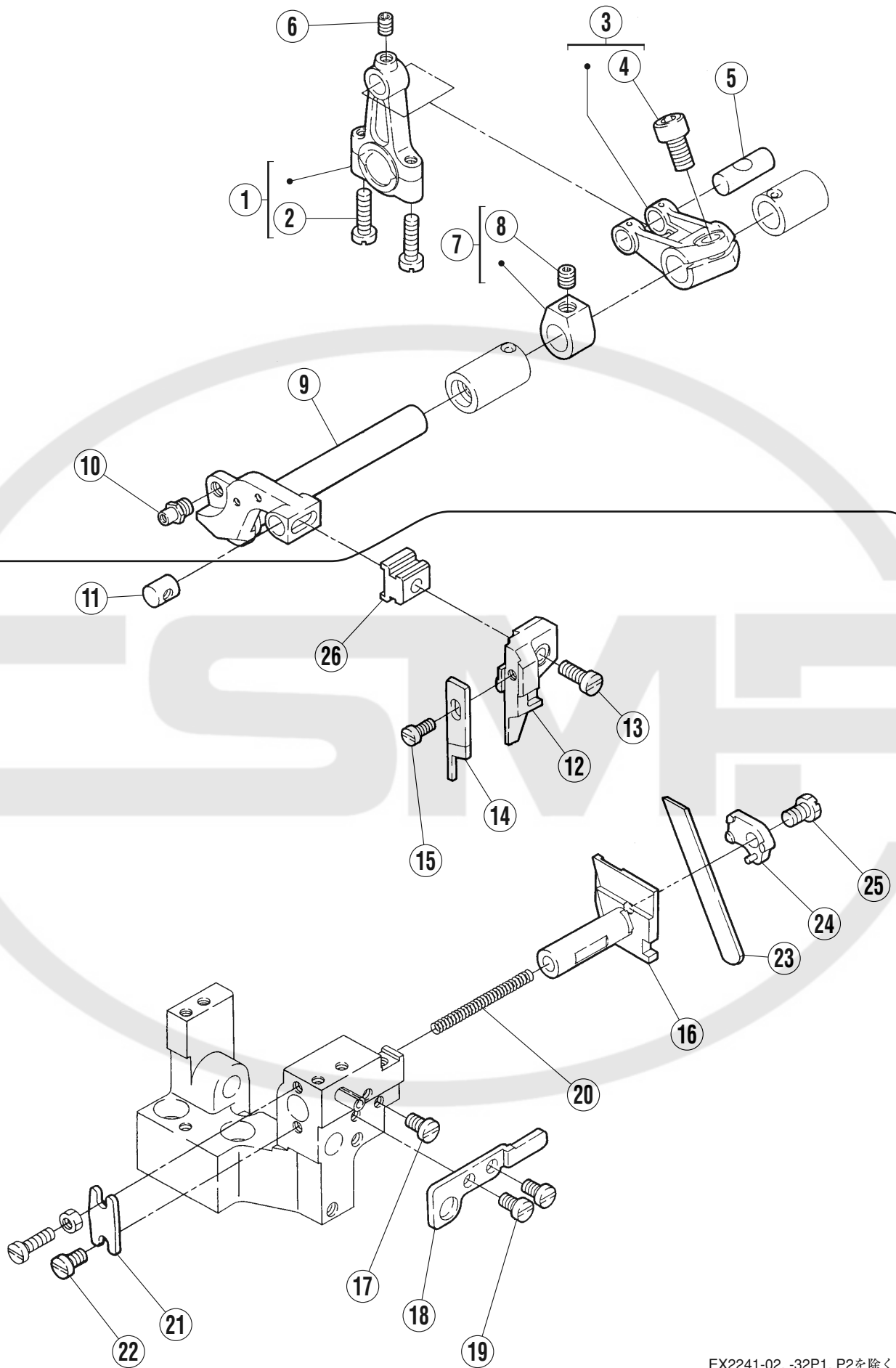

EX2241-02, -32P1, P2を除く  
 Except EX2241-02, -32P1, P2



## 上下メス機構

## KNIFE DRIVE MECHANISM

REF.NO.	PART NO.	部品名称	DESCRIPTION	QT.
1	273000-920	ロッド	CONNECTION	1
2	007023A0	平ネジ/M4×16	SCREW	2
3	273001A920	クランク	CRANK	1
4	0045330	六角穴ボルト/M6×12	BOLT	1
5	2710010	ピン	PIN	1
6	0045380	止ネジ/M4×6	SCREW	1
7	240235-920	カラー	COLLAR	1
8	0045470	止ネジ/M6×5	SCREW	1
9	2730030	上メス台	UPPER KNIFE HOLDER	1
10	3080360	ピン付ネジ	SCREW	1
11	2730060	案内ピン	PIN	1
12	2730140	上メス抱キ	UPPER KNIFE CLAMP	1
13	0070250	平ネジ/M4×20	SCREW	1
14	XXXXXX	上メス	UPPER KNIFE	1
15	0070130	平ネジ/M3.5×8	SCREW	1
16	273009B0	下メス台	LOWER KNIFE HOLDER	1
17	0070190	平ネジ/M4×8	SCREW	1
18	2730100	案内/下メス台	LOWER KNIFE HOLDER GUIDE	1
19	007019A0	平ネジ/M4×8	SCREW	2
20	2403240	圧縮バネ	SPRING	1
21	2730070	当板	PLATE	1
22	007019A0	平ネジ/M4×8	SCREW	1
23	XXXXXX	下メス	LOWER KNIFE	1
24	2730120	下メス押工	LOWER KNIFE CLAMP	1
25	0071730	六角ボルト/M5×8	BOLT	1
26	2730130	スペーサー	SPACER	1

●XXXXXXはゲージパーツです。  
部品番号は、46頁のゲージパーツ表で確認してください。

●"XXXXXX" represents the gauge part.  
Please refer to the gauge part list on page 46.

EX2241-02  
EX2241-42P2

EX2241-02を除く  
Except EX2241-02 26  
EX2241-02 40

EX2241-02, -42P2を除く  
Except EX2241-02, -42P2

EX2241-32P1, P2

EX2241-32P1, P2を除く  
Except EX2241-32P1, P2

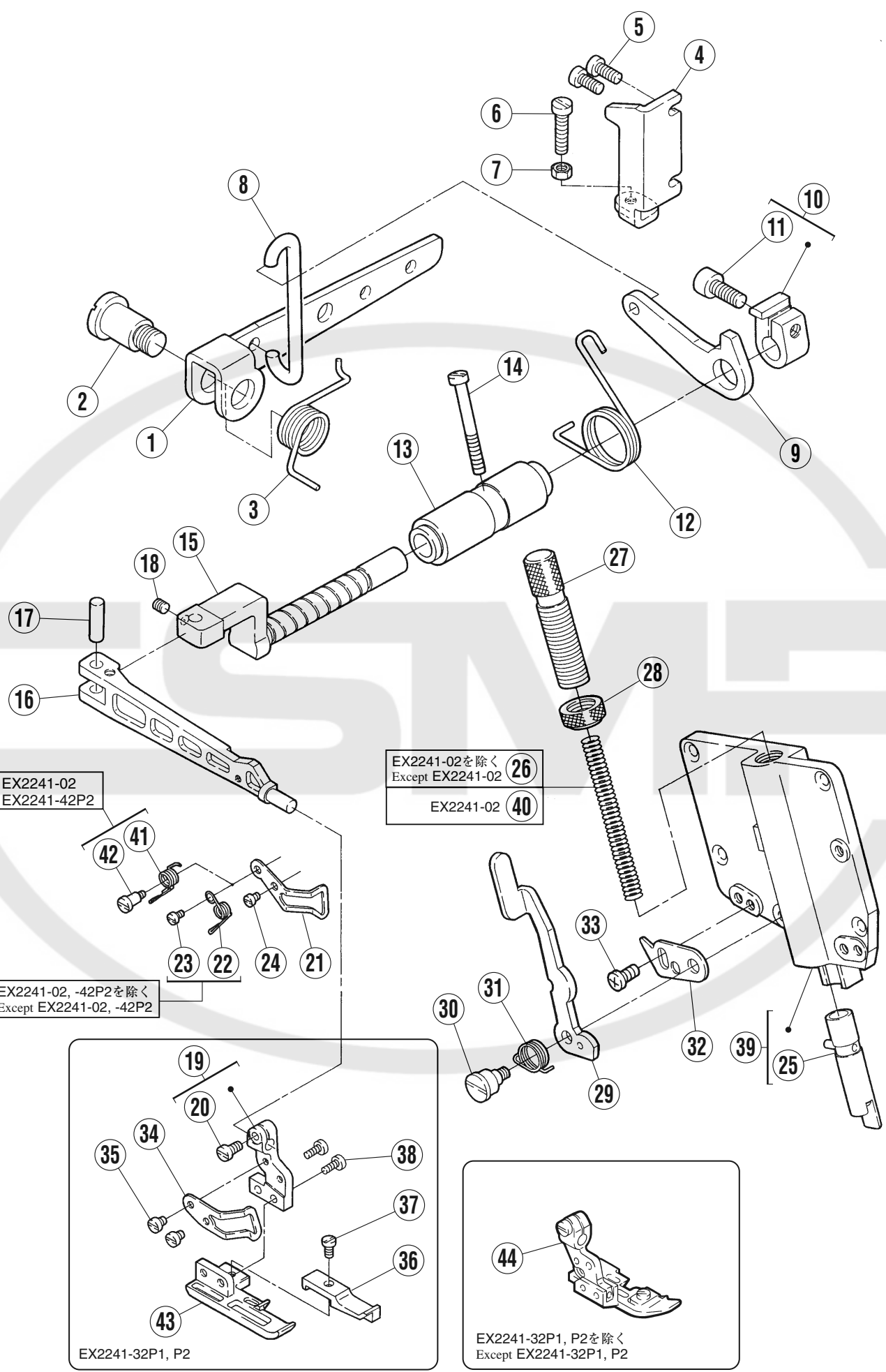

押工機構

PRESSER FOOT MECHANISM

REF.NO.	PART NO.	部品名称	DESCRIPTION	QT.
1	2740070	レバー	LEVER	1
2	0070600	段付ネジ/M10	SCREW	1
3	2740080	ネジリバネ	SPRING	1
4	2740090	ストッパー	STOPPER	1
5	007020A0	平ネジ/M4×10	SCREW	2
6	0071750	平ネジ/M5×24	SCREW	1
7	0048050	六角ナット/M5	NUT	1
8	2740060	リンク	LINK	1
9	2740040	レバー	LEVER	1
10	274003-921	カラー	COLLAR	1
11	0045340	六角穴ボルト/M6×14	BOLT	1
12	2740050	ネジリバネ	SPRING	1
13	2740020	ブッシュ	BUSHING	1
14	0071050	平ネジ/M4×40	SCREW	1
15	2740010	軸/押工台	SHAFT	1
16	274000-B0	押工台	PRESSER ARM	1
17	2085490	平行ピン	PIN	1
18	0045940	止ネジ/M4×4	SCREW	1
19	274061-920	ホルダー	HOLDER	1
20	0070130	平ネジ/M3.5×8	SCREW	1
21	274027A0	フィンガーガード	FINGER GUARD	1
22	2740580	ネジリバネ	SPRING	1
23	0070090	平ネジ/M3×5	SCREW	1
24	0070080	平ネジ/M3×4	SCREW	1
25	274011-910	押工棒	PRESSER BAR	1
26	2087730	圧縮バネ	SPRING	1
27	274014A1	調節ネジ	SCREW	1
28	2740150	ナット	NUT	1
29	2740160	レバー	LEVER	1
30	0071710	段付ネジ/M4	SCREW	1
31	2740170	ネジリバネ	SPRING	1
32	2740100	ストッパー	STOPPER	1
33	0070190	平ネジ/M4×8	SCREW	1
34	274026A0	フィンガーガード	FINGER GUARD	1
35	0070080	平ネジ/M3×4	SCREW	2
36	XXXXXX	小押工	SHOE/PRESSER FOOT	1
37	0012290	平ネジ/C3×4.5	SCREW	1
38	0011960	平ネジ/C3×6.5	SCREW	2
39	270083-9U0	側面カバー (組)	SIDE COVER ASSEMBLY	1
40	2403471	圧縮バネ	SPRING	1
41	2740240	ネジリバネ	SPRING	1
42	0071660	段付ネジ/M3	SCREW	1
43	XXXXXX	押工	PRESSER FOOT	1
44	XXXXXX	押工 (組)	PRESSER FOOT ASSEMBLY	1

●XXXXXXはゲージパーツです。  
部品番号は、46頁のゲージパーツ表で確認してください。

●"XXXXXX" represents the gauge part.  
Please refer to the gauge part list on page 46.

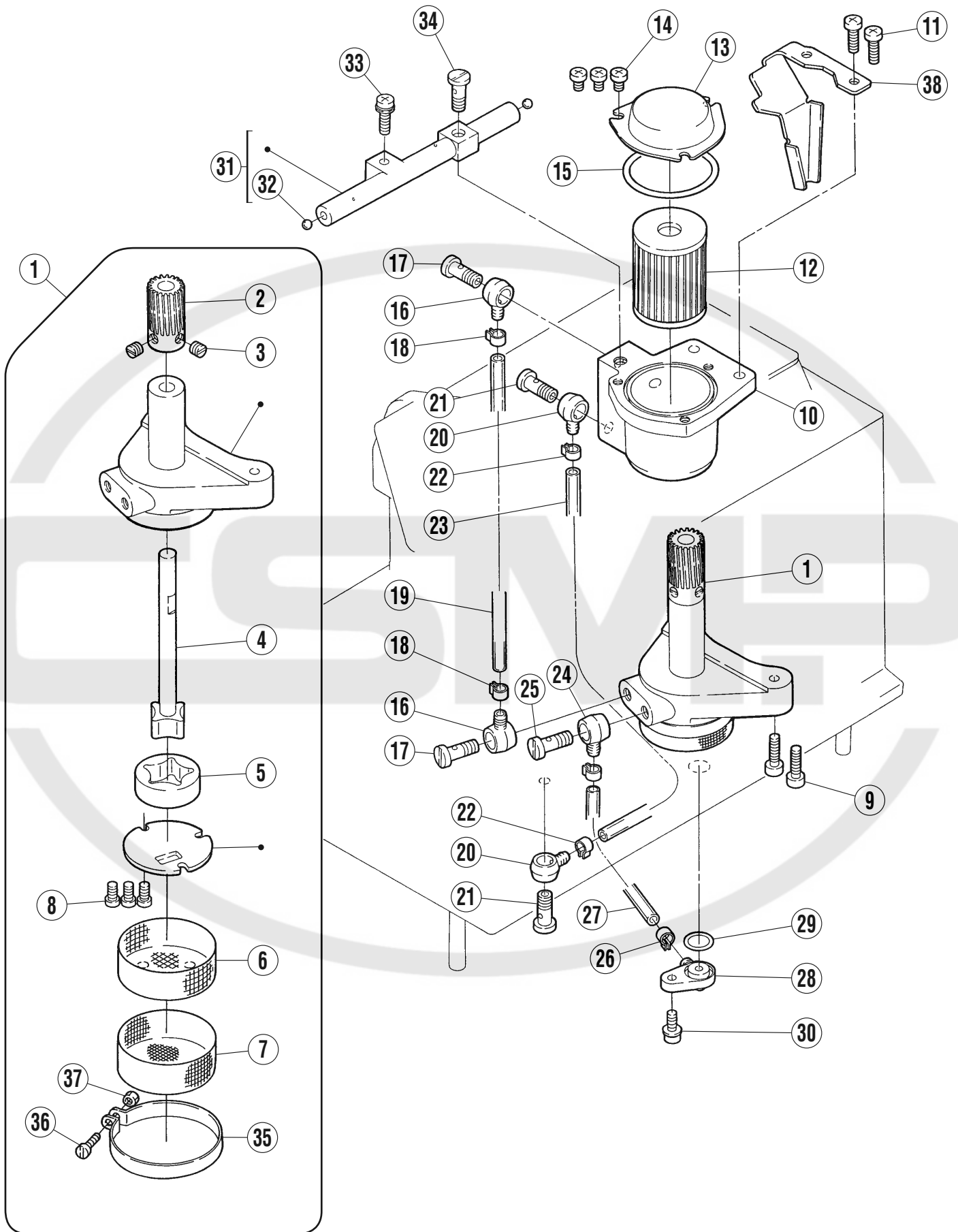

## 給油機構 (1)

## LUBRICATION MECHANISM (1)

REF.NO.	PART NO.	部品名称	DESCRIPTION	QT.
1	274505A910	ポンプ	PUMP	1
2	2116180	ウォームホイール	WORM WHEEL	1
3	0050600	止ネジ/C8×4.5	SCREW	2
4	212978-910	ローター (内) 軸	ROTOR (INSIDE) SHAFT	1
5	2129810	ローター (外)	ROTOR (OUTSIDE)	1
6	2094080	フィルタ	FILTER	1
7	2094090	フィルタ	FILTER	1
8	0070120	平ネジ/M3.5×8	SCREW	3
9	0045290	六角穴ボルト/M4×16	BOLT	2
10	2745090	タンク	TANK	1
11	007022A0	平ネジ/M4×14	SCREW	2
12	2062330	エレメント	OIL FILTER	1
13	2745100	蓋	COVER	1
14	007018A0	平ネジ/M4×6	SCREW	3
15	2403070	Oリング	O RING	1
16	2001360	継手	JOINT	2
17	2403280	継手ネジ	JOINT SCREW	2
18	2021990	クランプ	CLAMP	2
19	2403270	チューブ	TUBE	1
20	2001360	継手	JOINT	2
21	2403280	継手ネジ	JOINT SCREW	2
22	2021990	クランプ	CLAMP	2
23	2401350	チューブ	TUBE	1
24	2001360	継手	JOINT	1
25	2403280	継手ネジ	JOINT SCREW	1
26	2021990	クランプ	CLAMP	2
27	2403340	チューブ	TUBE	1
28	2745120	継手	JOINT	1
29	2400200	Oリング	O RING	1
30	004210-HU0	平ネジ/M4×12	SCREW	1
31	274515-910	油分配器 (組)	OIL DISTRIBUTOR ASSEMBLY	1
32	2102140	栓	PLUG	2
33	004211-HU0	平ネジ/M4×16	SCREW	1
34	2403280	継手ネジ	JOINT SCREW	1
35	2094100	クランプ	CLAMP	1
36	0070110	平ネジ/M3×8	SCREW	1
37	0048000	六角ナット	NUT	1
38	2745250	給油案内	OIL GUIDE	1

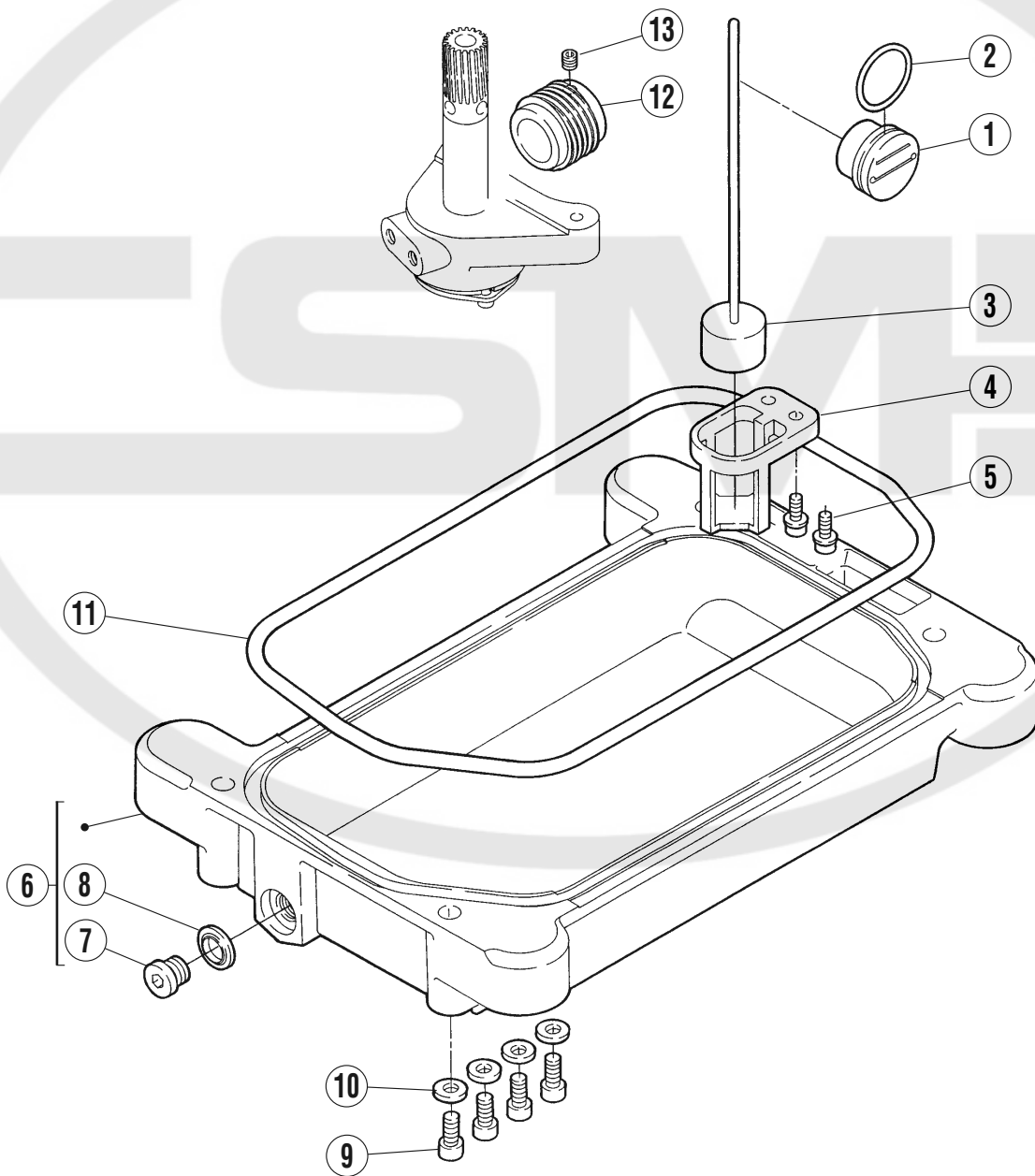
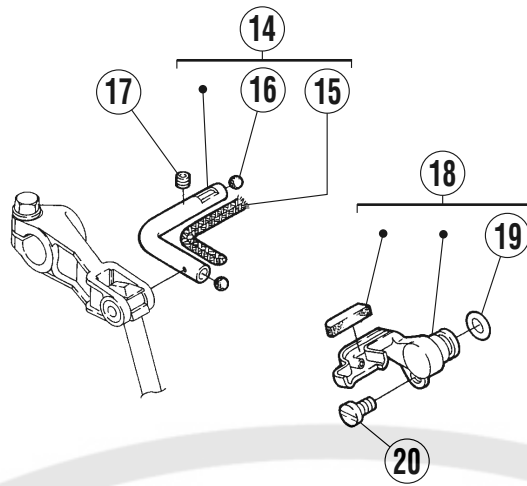

## 給油機構 (2)

## LUBRICATION MECHANISM (2)

REF.NO.	PART NO.	部品名称	DESCRIPTION	QT.
1	274502A0	オイルゲージ	OIL SIGHT GAUGE	1
2	2300430	Oリング	O RING	1
3	210193A910	オイル指示 (組)	INDICATOR ASSEMBLY	1
4	2105100	オイル指示受	OIL INDICATOR SUPPORT	1
5	004210-HU0	平ネジ/M4×12	SCREW	2
6	274503-910	オイルパン (組)	OIL RESERVOIR ASSEMBLY	1
7	005138B0	平ネジ/H11×12	SCREW	1
8	202287A0	ガスケット	GASKET	1
9	0045310	六角穴ボルト/M5×12	BOLT	4
10	2403390	座金	WASHER	4
11	2745010	ガスケット	GASKET	1
12	2745070	ウォーム	WORM	1
13	0045140	止ネジ/M5×5	SCREW	1
14	274516-910	パイプ (組)	PIPE ASSEMBLY	1
15	2021750	給油紐	OIL STRING	1
16	2400970	栓	PLUG	2
17	0045430	止ネジ/M4×4	SCREW	1
18	274523-910	継手 (組)	JOINT	1
19	2041850	Oリング	O RING	1
20	007019A0	平ネジ/M4×8	SCREW	1

EX2241-02

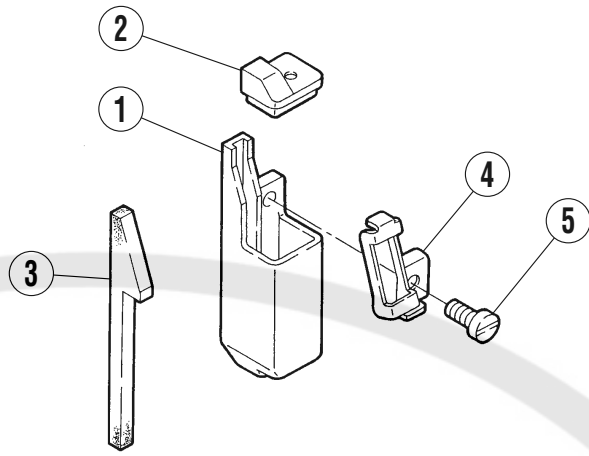

EX2241-32P1, P2を除く  
Except EX2241-32P1, P2

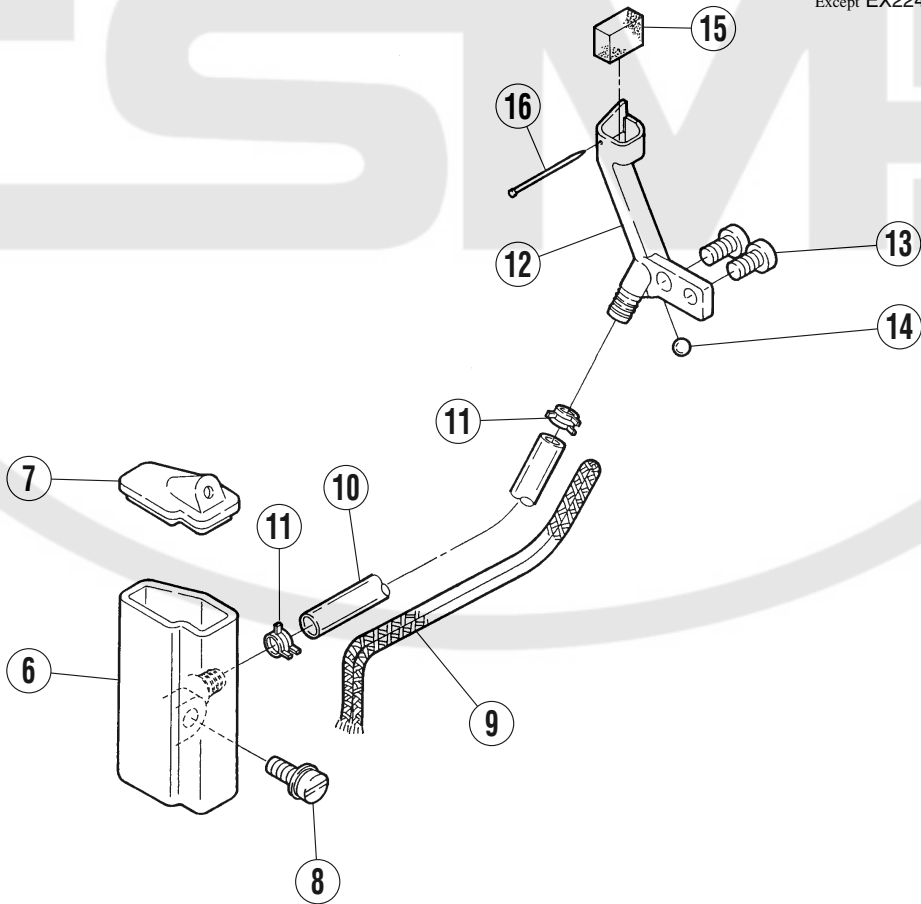



## H.R.装置

## H.R. DEVICE

REF.NO.	PART NO.	部品名称	DESCRIPTION	QT.
1	2755000	シリコンタンク (上)	SILICONE OIL RESERVOIR (UPPER)	1
2	2755010	蓋	COVER	1
3	2755080	フェルト	FELT	1
4	2755070	糸案内	THREAD GUIDE	1
5	007020A0	平ネジ/M4×10	SCREW	1
6	2755040	シリコンタンク (下)	SILICONE OIL RESERVOIR (LOWER)	1
7	2755050	蓋	COVER	1
8	004210-HU0	平ネジ/M4×12	SCREW	1
9	2021750	給油紐	OIL STRING	1
10	2403310	チューブ	TUBE	1
11	2001550	クランプ	CLAMP	2
12	275509A0	針冷却器	NEEDLE THREAD LUBRICATOR	1
13	007019A0	平ネジ/M4×8	SCREW	2
14	2102140	栓	PLUG	1
15	2044660	給油フェルト	OIL FELT	1
16	2107660	止ピン	PIN	1



CSTMP

- |                 |   |
|-----------------|---|
| 3 本立<br>3-spool | 1 |
| 4 本立<br>4-spool | 2 |

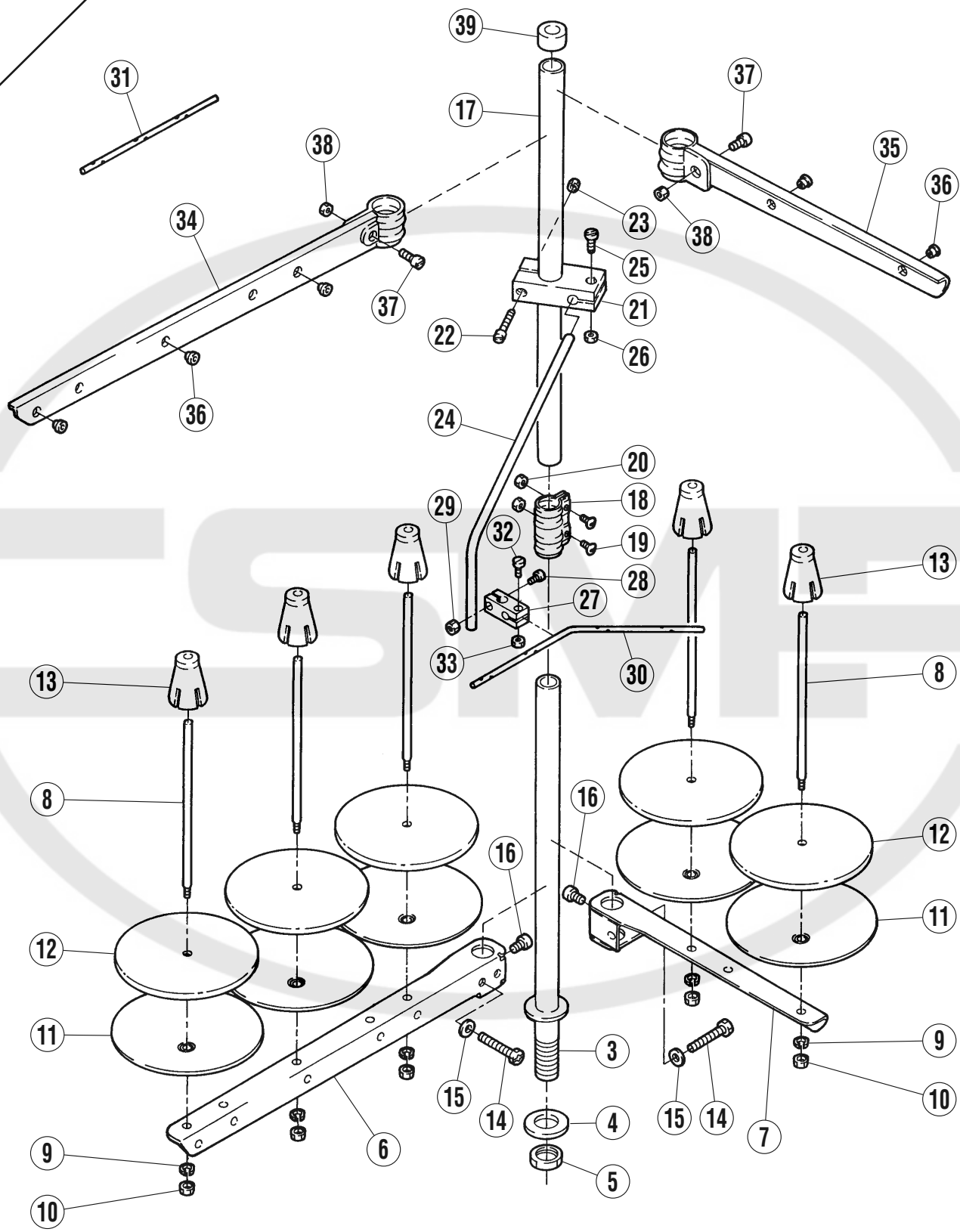

## 糸立台

## THREAD STAND

REF.NO.	PART NO.	部品名称	DESCRIPTION	QT.
1	000486C9P0	糸立 (組) (3本立)	THREAD STAND ASSEMBLY (3-SPOOL)	0 1
2	000486B9P0	糸立 (組) (4本立)	THREAD STAND ASSEMBLY (4-SPOOL)	1 0
3	000503-PA0	スタンド棒 (下)	COLUMN PIPE (LOWER)	1 1
4	0005090	座金	WASHER	1 1
5	0054760	六角ナット	NUT	1 1
6	000505-PA0	ブラケット (3本立)	BRACKET (3-SPOOL)	0 1
7	000505APA0	ブラケット (2本立)	BRACKET (2-SPOOL)	2 0
8	000380A0	糸立棒	SPOOL PIN	4 3
9	2012520	バネ座金	SPRING WASHER	4 3
10	0048030	六角ナット/M4	NUT	4 3
11	000381-PA0	受皿	SPOOL SEAT DISC	4 3
12	0005070	ウレタン	SPOOL MAT	4 3
13	000382-PA0	揺れ止め	SPOOL CUSHION	4 3
14	0071020	六角ネジ/M6×32	SCREW	2 1
15	0005120	座金	WASHER	2 1
16	0040220	平ネジ/M6×10	SCREW	2 1
17	000502-PA0	スタンド棒 (上)	COLUMN PIPE (UPPER)	1 1
18	000504-PA0	ジョイント	JOINT	1 1
19	0040210	平ネジ/M5×16	SCREW	2 2
20	0048050	六角ナット/M5	NUT	2 2
21	000383-PA0	ブラケット	HOLDER	1 1
22	0040140	平ネジ/M4×25	SCREW	1 1
23	0048030	六角ナット/M4	NUT	1 1
24	0003840	糸道棒腕	THREAD GUIDE ARM	1 1
25	0040120	平ネジ/M4×12	SCREW	1 1
26	0048030	六角ナット/M4	NUT	1 1
27	000233-PA0	ホルダー	HOLDER	1 1
28	0040120	平ネジ/M4×12	SCREW	1 1
29	0048030	六角ナット/M4	NUT	1 1
30	000293B0	糸道棒 (4本立)	THREAD GUIDE (4-SPOOL)	1 0
31	000293C0	糸道棒 (3本立)	THREAD GUIDE (3-SPOOL)	0 1
32	0040120	平ネジ/M4×12	SCREW	1 1
33	0048030	六角ナット/M4	NUT	1 1
34	000527-PA0	ブラケット (3本立)	BRACKET (3-SPOOL)	0 1
35	000527APA0	ブラケット (2本立)	BRACKET (2-SPOOL)	2 0
36	0005060	糸目穴	THREAD EYELET	4 3
37	0041170	平ネジ/M5	SCREW	2 1
38	0048050	六角ナット/M5	NUT	2 1
39	0003860	キャップ	ROD CAP	1 1

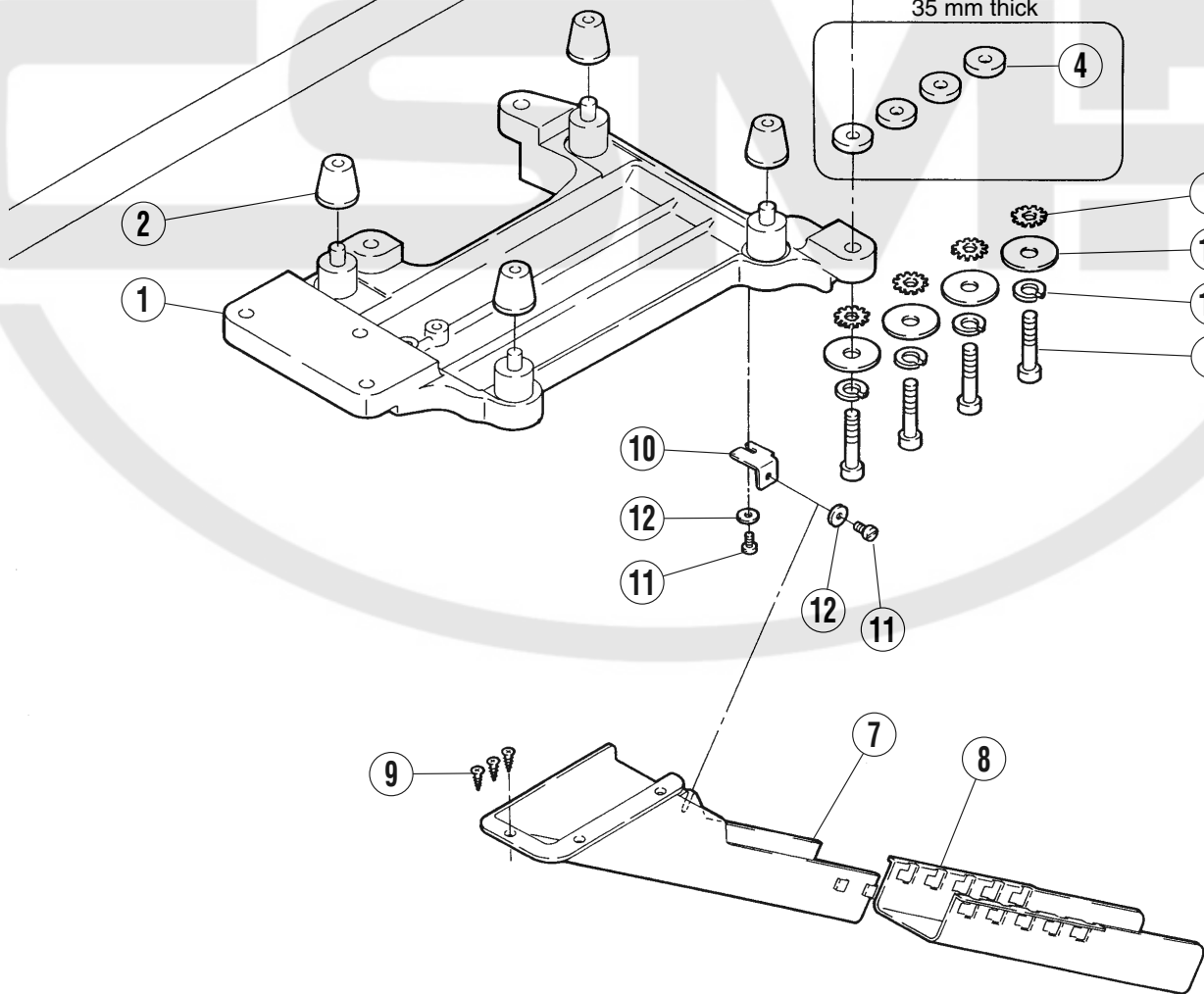
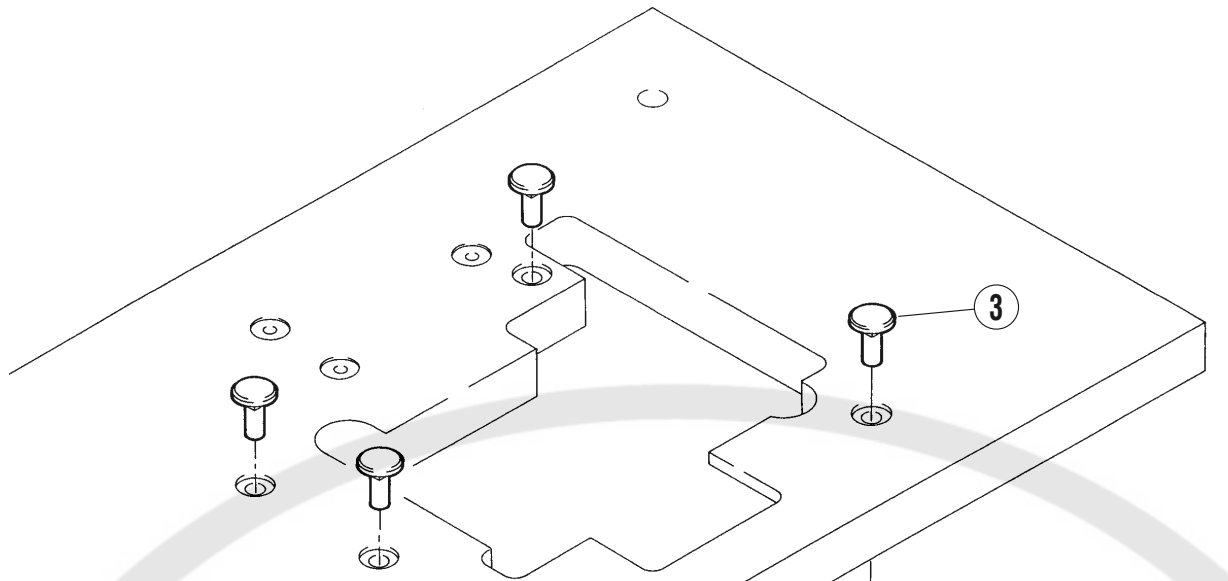

## 半沈床式据付附属品

## PARTS FOR SEMI-SUBMERGED INSTALLATION

REF.NO.	PART NO.	部品名称	DESCRIPTION	QT.
1	2760010	据付板	REST BOARD	1
2	179483-050	クッションゴム	CUSHION RUBBER	4
3	2063360	半沈用ナット/M8	NUT	4
4	2054670	スペーサー	SPACER	4
5	0045750	六角穴ボルト/M8×45	BOLT	4
6	2403040	歯付座金	WASHER	4
7	276002-UA0	シュータ (上)	WASTE CHUTE TOP	1
8	276003-UA0	シュータ (下)	WASTE CHUTE EXTENSION	1
9	0049040	木ネジ/3.5	SCREW	3
10	2760040	取付板	BRACKET	1
11	0041090	平ネジ/M4×10	SCREW	2
12	2401040	座金	WASHER	2
13	2063370	座金	WASHER	4
14	2014770	バネ座金	SPRING WASHER	4



EX2242-52P2  
EX2241-42P2  
EX2241-52P2

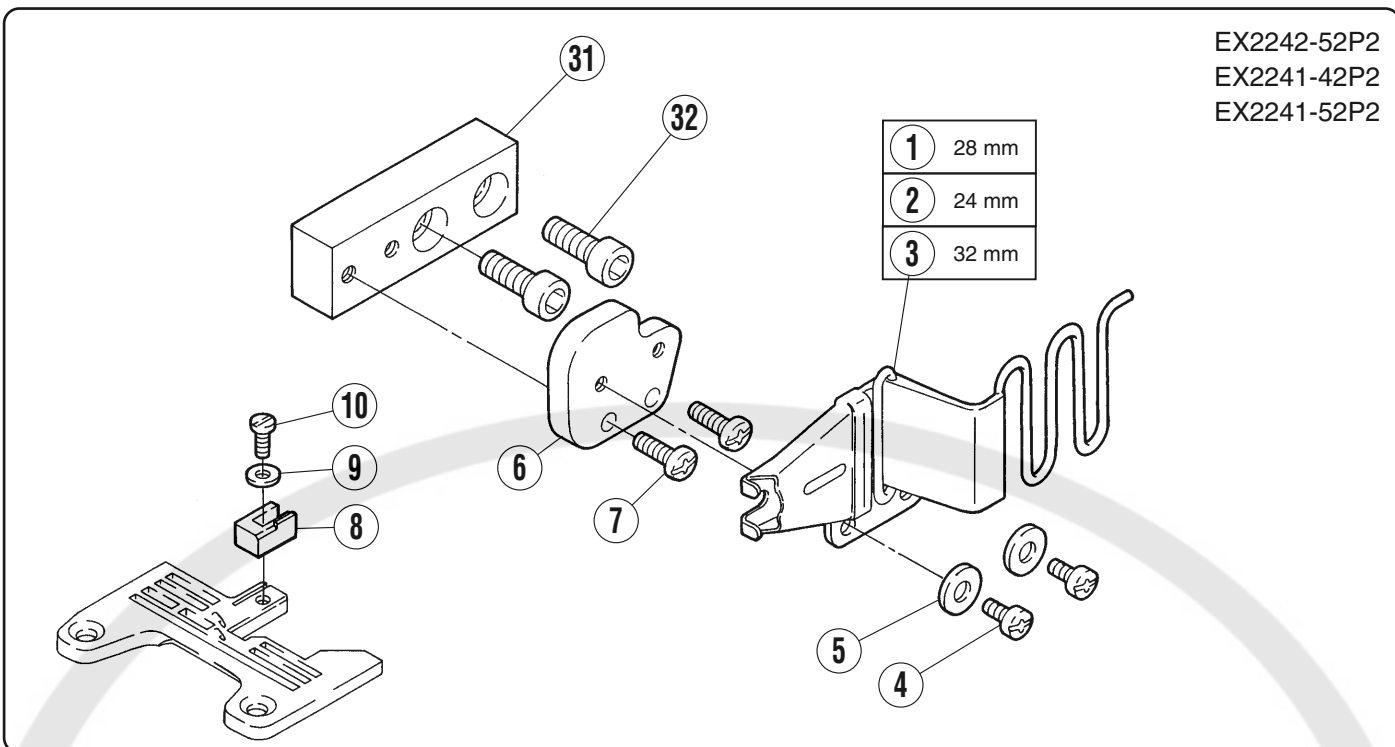

EX2241-32P1, P2

EX2241-32P2のみ

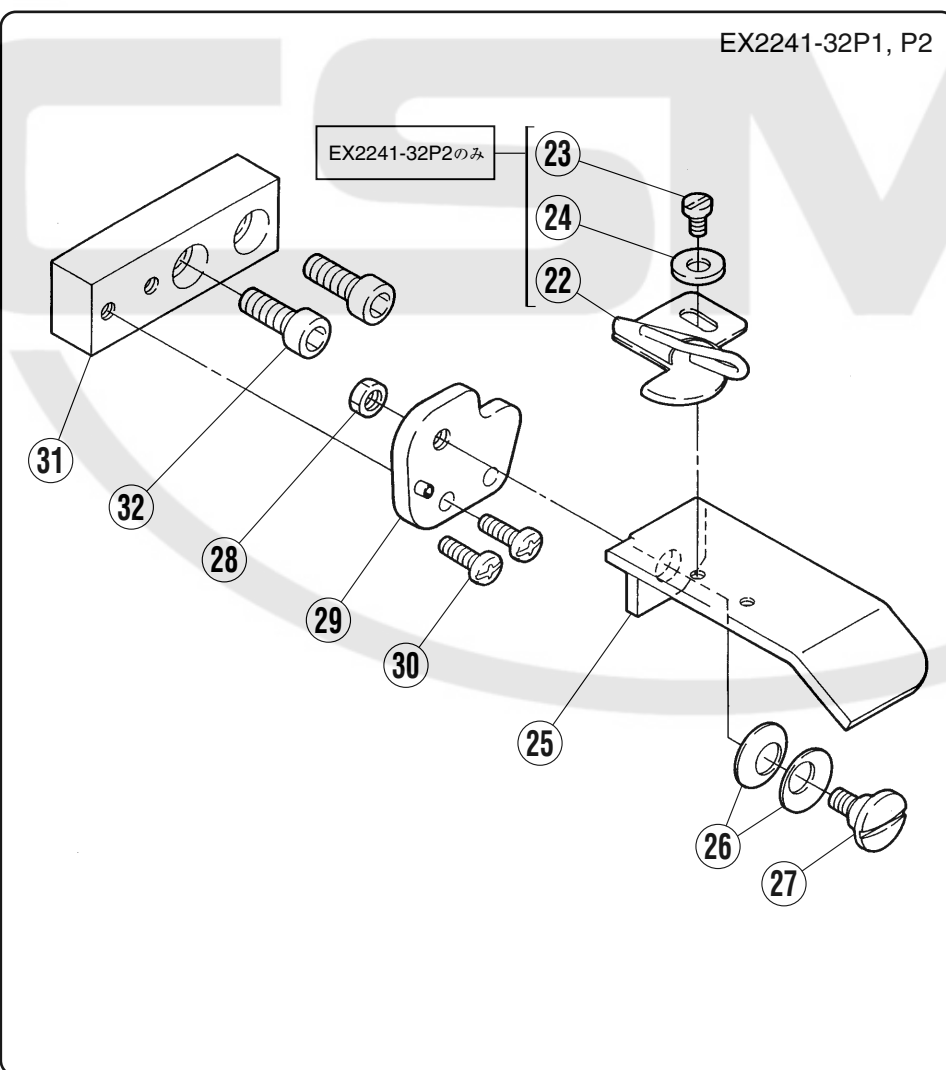

EX2242-52P2  
EX2241-42P2  
EX2241-52P2

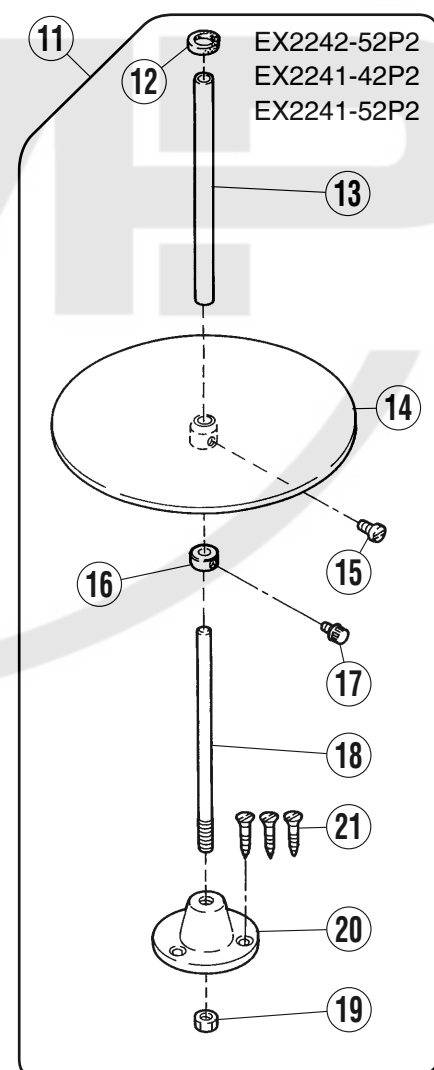

## 専用部品

## SPECIFIC PARTS

REF.NO.	PART NO.	部品名称	DESCRIPTION	QT.
1	2083890	バインダー (組) (28)	BINDER ASSEMBLY (28)	1
2	2083900	バインダー (組) (24)	BINDER ASSEMBLY (24)	1
3	2087570	バインダー (組) (32)	BINDER ASSEMBLY (32)	1
4	007013A0	平ネジ/M3.5×8	SCREW	2
5	1371420	座金	WASHER	2
6	2700860	ブラケット	BRACKET	1
7	007021A0	平ネジ/M4×12	SCREW	2
8	2085690	補助板	TAPE GUIDE	1
9	2028750	座金	WASHER	1
10	0070110	平ネジ/M3×8	SCREW	1
11	000403-9S0	テープガイド (組)	TAPE DISC ASSEMBLY	1
12	0004060	フェルト	FELT	1
13	0004050	取付棒	FIXING ROD	1
14	0004040	カノコ台	TAPE DISC	1
15	0040120	平ネジ/M4×12	SCREW	1
16	0004070	カラー	COLLAR	1
17	0004080	調節ネジ	ADJUSTING SCREW	1
18	0004090	軸	SHAFT	1
19	0048180	六角ナット/M6	NUT	1
20	000410-SA0	ブラケット	BRACKET	1
21	0049080	木ネジ (皿) /4.5	SCREW	3
22	2086380	バインダー (組)	BINDER	1
23	0012160	平ネジ/C4×5.5	SCREW	1
24	1371420	座金	WASHER	1
25	2118610	補助クロスプレート	BRACKET	1
26	2048880	皿バネ	SPRING WASHER	2
27	0053800	段付ネジ/C8	SCREW	1
28	0051040	六角ナット/C8	NUT	1
29	270087-910	ブラケット	BRACKET	1
30	007021A0	平ネジ/M4×12	SCREW	2
31	2700850	ブラケット	BRACKET	1
32	0045100	六角穴ボルト/M6×16	BOLT	2

EX2200 ゲージパーツ表

EX2200 GAUGE PARTS LIST

マシン形式 MACHINE TYPE /SPEC	ゲージ GAUGE		針板 NEEDLE PLATE	主送り歯(組) MAIN FEED DOG ASSY.	主送り歯本体 MAIN FEED DOG	補助送り歯 AUX. FEED DOG	差動送り歯 DIFF. FEED DOG	押エ(組) PRESSER FOOT ASSY.	小押し SHOE PRESSER FOOT	ルーパー LOOPER	針受(前) NEEDLE GUARD FRONT	針受(後) NEEDLE GUARD REAR
	NG	SW										
<b>EX2241-52P2/083</b>	-	24	277548R0	277359-160	(277360-160)	(277361-160)	277362-160	2771940	—	2770380	2770410	2770420
	-	28										
	-	32										
<b>EX2241-42P2/083</b>	-	24	277548R0	277359-160	(277360-160)	(277361-160)	277362-160	2771960	—	2770380	2770410	2770420
	-	28										
	-	32										
<b>EX2242-52P2/083</b>	5	24	277549R0	277359-160	(277360-160)	(277361-160)	277362-160	2771950	—	2770380 (2ヶ) (2 pieces)	2770410 2770080	2770420 2770060
	-	28										
	-	32										
<b>EX2241-32P1/063</b>	-	4	277550R0	—	277363-160	—	277364-160	2087670	2087680	2770380	2770080	2770060
	-	5										
	-	6										
<b>EX2241-32P2/063</b>	-	4	277550R0	—	277363-160	—	277364-160	2087670	2087680	2770380	2770080	2770060
	-	5										
	-	6										
<b>EX2241-02/083</b>	-	-	277591R0	—	277433-160	—	277434-160	2780220	—	2770380	2770080	2770060

EX2200 ゲージパーツ表

EX2200 GAUGE PARTS LIST

マシン形式 MACHINE TYPE /SPEC	ゲージ GAUGE		針留 NEEDLE HOLDER	上メス UPPER KNIFE	下メス LOWER KNIFE	針 NEEDLE
	NG	SW				
<b>EX2241-52P2/083</b>	-	24	179630-920	202527A0	2022950	DCX27 #14
	-	28				
	-	32				
<b>EX2241-42P2/083</b>	-	24	179630-920	202527A0	2022950	DCX27 #14
	-	28				
	-	32				
<b>EX2242-52P2/083</b>	5	24	277028A920	202527A0	2022950	DCX27 #14
	-	28				
	-	32				
<b>EX2241-32P1/063</b>	-	4	277027-920	—	—	DCX27 #16
	-	5				
	-	6				
<b>EX2241-32P2/063</b>	-	4	277027-920	—	—	DCX27 #16
	-	5				
	-	6				
<b>EX2241-02/083</b>	-	-	277028-920	—	—	DCX27 #16



PART. NO.	PAGE	REF. NO.	PART. NO.	PAGE	REF. NO.	PART. NO.	PAGE	REF. NO.	PART. NO.	PAGE	REF. NO.	PART. NO.	PAGE	REF. NO.
000233-PA0	41	27	0045750	43	5	0070440	9	27	2081731	29	3	2403340	35	27
000293B0	41	30	0045940	33	18	0070550	23	27	2082350	15	10	2403350	9	11
000293C0	41	31	0048000	35	37	0070560	23	5	2083890	45	1	2403380	21	7
000380A0	41	8	0048030	41	10	0070560	23	20	2083900	45	2	2403390	37	10
000381-PA0	41	11	0048030	41	23	0070560	29	24	2084480	11	3	2403400	9	7
000382-PA0	41	13	0048030	41	26	0070580	27	22	2084490	11	6	2403400	9	17
000383-PA0	41	21	0048030	41	29	0070590	27	35	2085490	33	17	2403430	7	13
0003840	41	24	0048030	41	33	0070600	33	2	2085690	45	8	2403471	33	40
0003860	41	39	0048050	29	12	0070620	7	26	2086270	9	29	2405420	23	4
000403-9S0	45	11	0048050	33	7	0070620	13	9	2086380	45	22	2405420	23	19
0004040	45	14	0048050	41	20	0070660	7	29	2087570	45	3	2405420	29	23
0004050	45	13	0048050	41	38	0070660	25	6	2087730	33	26	2405590	27	43
0004060	45	12	0048180	45	19	0070770	7	18	2089490	23	12	2520690	27	34
0004070	45	16	0048210	7	37	0070820	13	2	2090840	3	7	2525150	23	11
0004080	45	17	0049040	43	9	0070840	7	32	2090840	21	10	2526580	27	37
0004090	45	18	0049080	45	21	0071020	41	14	2094080	35	6	263543-TA0	11	2
000410-SA0	45	20	0050600	35	3	0071050	33	14	2094090	35	7	263544-TA0	11	4
000486B9P0	41	2	005082A0	11	7	0071100	29	37	2094100	35	35	270008-910	3	4
000486C9P0	41	1	0051040	45	28	0071100	29	39	2100440	5	24	270011-AUDO	5	14
000502-PA0	41	17	005138B0	37	7	0071140	19	18	2100560	9	15	270011-UD0	5	28
000503-PA0	41	3	0053800	45	27	0071190	17	8	2100570	9	16	2700130	5	33
000504-PA0	41	18	0054760	41	5	0071190	17	12	2101290	27	6	270013C0	5	27
000505APAO	41	7	0070080	25	15	0071200	13	11	2101300	27	7	270013D0	5	32
000505-PA0	41	6	0070080	25	17	0071200	17	4	210193A910	37	3	2700140	5	15
0005060	41	36	0070080	33	24	0071500	15	13	2101940	3	2	2700150	7	17
0005070	41	12	0070080	33	35	0071510	9	2	2102140	35	32	2700170	5	31
0005090	41	4	0070090	5	21	0071610	27	27	2102140	39	14	2700180	5	20
0005120	41	15	0070090	33	23	0071660	33	42	2103070	7	5	2700190	7	23
000527APAO	41	35	0070100	19	10	0071671	25	8	2103070	7	30	270020-SD0	5	1
000527-PA0	41	34	0070100	19	12	0071671	25	27	2103070	25	7	2700210	5	3
0011960	33	38	0070100	19	16	0071700	19	2	2103190	11	5	2700230	7	33
0012160	45	23	0070100	29	7	0071710	33	30	2105100	37	4	270024-9U0	5	8
0012290	33	37	0070100	29	30	0071720	7	20	210529-9T0	11	1	2700250	5	12
004009-1HCO	11	13	0070110	9	4	0071730	31	25	210529-9T0	11	16	2700260	7	34
004009-1HCO	11	14	0070110	35	36	0071740	21	8	2106790	7	38	270030-UB0	7	9
0040120	41	25	0070110	45	10	0071750	33	6	2106790	7	39	2700330	7	25
0040120	41	28	0070120	35	8	0071760	5	11	2106790	7	40	2700340	7	28
0040120	41	32	0070130	23	29	0071800	7	16	2107660	39	16	2700350	7	1
0040120	45	15	0070130	29	31	0072380	29	15	2113010	27	36	270035F911	7	2
0040140	41	22	0070130	29	34	1371080	25	9	2113880	25	10	2700420	7	3
0040210	41	19	0070130	31	15	1371080	25	28	2113880	25	29	2700430	7	19
0040220	41	16	0070130	33	20	1371420	45	5	2115260	9	13	2700440	7	21
0041090	43	11	007013A0	45	4	1371420	45	24	2115280	9	18	2700450	7	22
0041170	41	37	0070140	23	25	179009-050	15	19	2116180	35	2	2700470	3	6
004210-HU0	35	30	0070170	13	7	179107-050	5	5	2118610	45	25	2700490	7	15
004210-HU0	37	5	0070170	25	13	179483-050	43	2	212978-910	35	4	270077-UB0	5	9
004210-HU0	39	8	007017A0	5	23	179498-920	25	18	2129810	35	5	270083-9U0	33	39
004211-HU0	35	33	007017A0	5	25	1921200	25	1	2129870	9	12	2700850	45	31
0045100	45	32	007018A0	5	26	2001360	35	16	2300430	37	2	2700860	45	6
0045110	3	5	007018A0	7	7	2001360	35	20	240012-20	27	4	270087-910	45	29
0045140	9	10	007018A0	7	12	2001360	35	24	2400200	35	29	270152A0	5	22
0045140	21	13	007018A0	11	10	2001550	39	11	2400390	23	6	2701770	7	31
0045140	27	11	007018A0	27	38	2005550	27	20	2400390	23	21	270500A0	9	1
0045140	37	13	007018A0	35	14	2005550	27	42	2400390	29	25	2705020	9	3
0045230	9	23	00701900	19	14	2010020	3	1	2400430	5	17	2705030	9	5
0045290	35	9	00701900	31	17	2010220	15	18	2400620	23	9	270504-UD0	9	21
0045310	23	8	00701900	33	33	2010220	29	18	2400620	29	13	2705050	9	20
0045310	37	9	007019A0	5	13	2010370	11	8	2400970	37	16	270507-910	9	8
0045330	15	6	007019A0	7	24	2012520	7	11	2401040	43	12	2705090	9	26
0045330	21	12	007019A0	19	4	2012520	41	9	2401100	5	6	2705100	9	25
0045330	23	15	007019A0	19	7	2014770	43	14	2401350	35	23	270523A0	9	30
0045330	23	17	007019A0	19	8	2021750	37	15	240235-920	31	7	2705260	9	31
0045330	27	25	007019A0	25	2	2021750	39	9	2402990	3	3	271000-920	15	1
0045330	29	6	007019A0	31	19	2021770	15	16	2403010	5	19	2710010	15	3
0045330	29	10	007019A0	31	22	2021990	35	18	2403030	29	20	2710010	27	2
0045330	31	4	007019A0	37	20	2021990	35	22	2403040	43	6	2710010	31	5
0045340	33	11	007019A0	39	13	2021990	35	26	2403050	5	4	271002-920	15	5
0045350	5	30	0070200	7	35	202287A0	37	8	2403050	5	10	2710030	15	7
0045350	27	8	0070200	9	28	2025220	27	23	2403050	7	8	271004-920	15	12
0045350	27	9	007020A0	9	19	2025770	15	11	2403050	7	14	271008A0	15	15
0045380	15	4	007020A0	33	5	2028490	11	12	2403050	19	5	271009-920	15	20
0045380	27	3	007020A0	39	5	2028490	11	15	2403060	9	14	2710100	19	3
0045380	31	6	007021A0	5	16	2028750	7	27	2403070	35	15	2710110	19	6
0045410	9	6	007021A0	27	32	2028750	45	9	2403080	15	8	271013A0	19	19
0045410	9	22	007021A0	45	7	204052A0	23	23	2403100	15	22	271022A910	15	14
0045430	5	18	007021A0	45	30	2041150	7	6	2403110	29	4	2710240	19	17
0045430	7	4	007022A0	5	2	2041850	27	29	2403140	27	18	271500-920	21	1
0045430	13	4	007022A0	21	3	2041850	37	19	2403150	27	17	2715010	21	4
0045430	15	9	007022A0	35	11	2042930	9	24	2403170	27	19	271504A0	21	6
0045430	29	21	007022A0	35	39	2044660	39	15	2403180	29	16	2725000	27	1
0045430	37	17	007023A0	7	36	2048880	45	26	2403190	29	17	2725010	27	5
0045460	15	17	007023A0	15	2	205015-20	23	2	2403210	27	33	2725020	27	15
0045470	31	8	007023A0	21	2	2050610	29	2	2403220	27	41	2725030	27	13
0045540	17	2	007023A0	31	2	2054670	43	4	2403240	31	20	272504-910	27	12
0045540	17	6	0070250	31	13	2061150	25	4	2403270	35	19	272506-910	27	10
0045540	17	10	007025A0	7	10	2061150	25	23	2403280	35	17	2725090	27	16
0045540	25	19	0070350	15	21	2062330	35	12	2403280	35	21	272510-910	29	5
0045720	9	9	0070380	27	14	2063360	43	3	2403280	35	25	272514-921	29	9
0045730	29	42	0070410	21	5	2063370	43	13	2403280	35	34	2725151	29	11
0045740	5	29	0070440	5	7	2063660	27	45	2403310	39	10	2725160	29	1

# インデックス

# INDEX

PART. NO.	PAGE	REF. NO.	PART. NO.	PAGE	REF. NO.	PART. NO.	PAGE	REF. NO.	PART. NO.	PAGE	REF. NO.	PART. NO.	PAGE	REF. NO.
2725170	23	18	275038A0	25	22									
2725170	29	22	2750390	25	16									
2725180	29	8	275061-910	25	25									
2725190	29	36	2750640	25	26									
2725200	29	38	2750650	13	10									
2725210	29	40	275066-910	25	24									
2725240	29	35	2755000	39	1									
2725250	29	14	2755010	39	2									
2725260	29	19	2755040	39	6									
2725270	29	26	2755050	39	7									
2725280	29	32	2755070	39	4									
2725290	27	21	2755080	39	3									
272530A920	27	24	275509A0	39	12									
2725320	27	26	2755400	3	9									
272533A1	27	28	2755410	3	8									
2725340	27	30	2760010	43	1									
2725350	27	31	276002-UA0	43	7									
272538A0	27	40	276003-UA0	43	8									
272539A0	27	44	2760040	43	10									
2726170	29	41	3030670	21	9									
273000-920	31	1	3030670	23	10									
273001A920	31	3	3034480	27	39									
2730030	31	9	3080360	31	10									
2730060	31	11												
2730070	31	21												
273009B0	31	16												
2730100	31	18												
2730120	31	24												
2730130	31	26												
2730140	31	12												
2735000	23	1												
2735010	23	3												
2735020	23	7												
2735040	23	13												
273505-920	23	14												
2735060	23	22												
273509-920	23	16												
273511-920	21	11												
273513-920	23	26												
274000-B0	33	16												
2740010	33	15												
2740020	33	13												
274003-921	33	10												
2740040	33	9												
2740050	33	12												
2740060	33	8												
2740070	33	1												
2740080	33	3												
2740090	33	4												
2740100	33	32												
274011-910	33	25												
274014A1	33	27												
2740150	33	28												
2740160	33	29												
2740170	33	31												
2740240	33	41												
274026A0	33	34												
274027A0	33	21												
2740580	33	22												
274061-920	33	19												
2745010	37	11												
274502A0	37	1												
274503-910	37	6												
274505A910	35	1												
2745070	37	12												
2745090	35	10												
2745100	35	13												
2745120	35	28												
274515-910	35	31												
274516-910	37	14												
274523-910	37	18												
2745250	35	38												
2750000	11	9												
2750010	11	11												
275019A0	17	3												
2750210	13	1												
2750220	13	3												
2750270	13	8												
2750280	13	5												
275028A0	13	6												
2750300	17	7												
2750300	17	11												
2750320	25	3												
2750330	25	5												
2750340	25	11												
2750340	25	30												
2750350	25	12												
2750360	25	14												
2750370	25	20												
2750380	25	21												



# ペガサスミシン製造株式会社

本社 〒553-0002 大阪市福島区鷺洲5-7-2 TEL (06)6458-4739  
FAX (06)6454-8785

PEGASUS SEWING MACHINE MFG. CO., LTD.  
5-7-2, Sagisu, Fukushima-ku, Osaka 553-0002, Japan. Phone :(06)6458-4739  
Telefax:(06)6454-8785

Cat. No. 9B600600000 May 2002

© 2002 PEGASUS SEWING MACHINE MFG. CO., LTD.

このパーツカタログに記載されている内容は、改良のため予告なく変更することがあります。

The description in this PARTS CATALOG is subject to change without notice.