

E22 SERIES

First edition; issued in April, 1991

初 版 (1991年 4月 発行)



PEGASUS®

www.collegesewing.co.uk



パーツカタログの見方

- このパーツカタログは、1991年4月製造中のE22のミシンを次の要領で編集しています。
- 2～41頁には部品を機構別に収録し、左頁が部品の分解図、右頁がパーツリストになっています。
また、部品分解図に付されている番号は、パーツリストのREF.NO.(参照番号)を示しています。
- ゲージパーツ系列構成図・ゲージパーツ表(42～44頁)
これらの部品は、特定の形式にのみ使用されている部品で、系列構成図は42～43頁に、ゲージパーツ表は44頁に一括して記載しています。
- 46～47頁には部品番号インデックスを記載し、部品番号だけで、その図解、名称などが容易に引き出せます。
- 部品をご注文いただくときは、必ず部品番号だけを明示してください。
なお、このパーツカタログの記載事項は改良により、予告なく変更されることがありますので、あらかじめご了承ください

INTRODUCTION

- This parts catalog covers the E22 machine manufactured April, 1991.
- On pages 2～41, each mechanism is arranged on facing pages, the first page containing the illustrations and the second page containing the data of the individual parts.
The number given to each illustration is the REF. NO. on the parts list.
- Gauge parts construction charts/gauge parts lists.
Gauge parts are used in some machine types and sewing gauges only. Pages 42～43 contain the gauge parts construction charts in order to know the illustrations and the combinations of the parts, and page 44 contain the gauge parts lists to obtain the data at a glance.
- A part number index is attached to the back of this catalog for convenience.
- When placing orders for parts from this catalog, use ONLY THE PART NUMBER.
- This parts catalog is applicable to your machine and is subject to change without notification.

目次

	頁
アーム、ベッド機構	2—3
カバー機構(1)	4—5
カバー機構(2)	6—7
クランクシャフト機構	8—9
針振り機構(1)	10—11
針振り機構(2)	12—13
ルーパー機構(1)	14—15
ルーパー機構(2)	16—17
送り機構(1)	18—19
送り機構(2)	20—21
送り機構(3)	22—23
上下メス機構	24—25
押エ機構(1)	26—27
押エ機構(2)	28—29
給油機構	30—31
H.R. 装置	32—33
アタッチメント	34—35
糸立台	36—37
半沈床式据付付属品	38—39
付属品	40—41
ゲージパーツ系列構成図	42—43
ゲージパーツ表	44
部品番号インデックス	45—46

TABLE OF CONTENTS

	Page
Machine bed frame	2—3
Cover (1)	4—5
Cover (2)	6—7
Crankshaft drive mechanism	8—9
Needle drive mechanism (1)	10—11
Needle drive mechanism (2)	12—13
Looper drive mechanism (1)	14—15
Looper drive mechanism (2)	16—17
Feed mechanism (1)	18—19
Feed mechanism (2)	20—21
Feed mechanism (3)	22—23
Knife drive mechanism	24—25
Presser foot mechanism (1)	26—27
Presser foot mechanism (2)	28—29
Lubrication mechanism	30—31
H. R. device	32—33
Attachment	34—35
Thread stand	36—37
Parts for semi-submerged installation	38—39
Accessories	40—41
Gauge parts construction charts	42—43
Gauge parts lists	44
Part number index	45—46

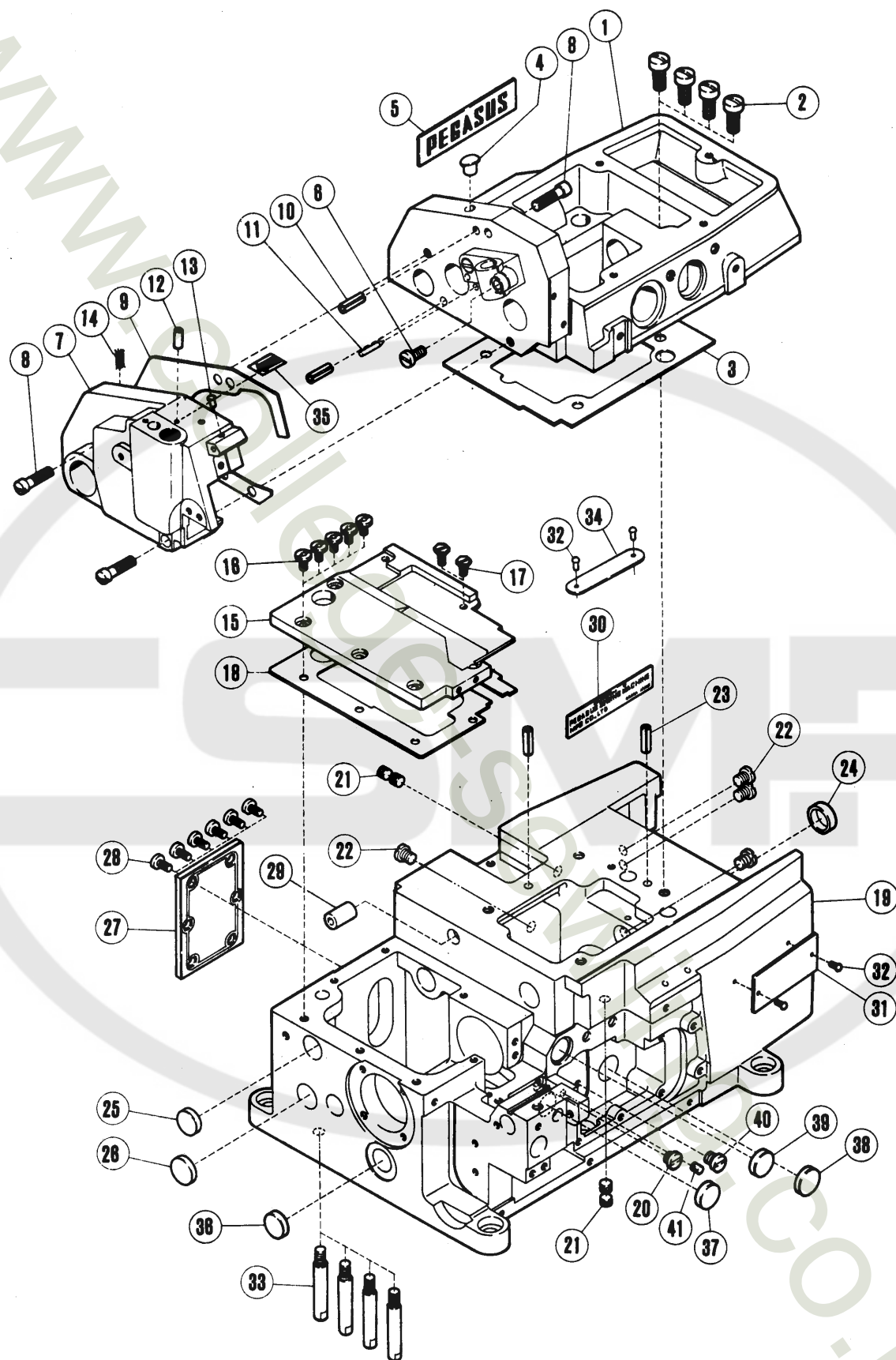

アーム、ベッド機構

MACHINE BED FRAME

REF. NO.	PART NO. 部品番号	名称	NAME	QT.
1	210218-HD	アーム (右)	MACHINE ARM (RIGHT)	1
2	5078	平ネジ / C 11 × 1.5	SCREW	4
3	210002	ガスケット	GASKET	1
4	240052	栓	PLUG	1
5	210525	銘板	NAME PLATE	1
6	5357	平ネジ / C 9 × 1.1	SCREW	1
7	210219-HD	アーム (左)	MACHINE ARM (LEFT)	1
8	5163	平ネジ / C 8 × 2.0	SCREW	3
9	210220	ガスケット	GASKET	1
10	201002	スプリングピン	PIN	2
11	240190	ピン	PIN	1
12	210528	給油パイプ	OIL PIPE	1
13	198192	当ゴム	CUSHION RUBBER	1
14	202174	給油紐	OIL WICK	1
15	210008	上蓋	COVER PLATE	1
16	4009-1	平ネジ / C 5 × 7.5	SCREW	5
17	5482	六角ネジ / C 5 × 7.5	SCREW	2
18	210009	ガスケット	GASKET	1
19	212327-FD	ベッド	MACHINE BED	1
20	5434	平ネジ / C 10 × 4	SCREW	1
21	2913-1	止ネジ / C 10 × 4.5	SCREW	4
22	5332A	平ネジ / C 10 × 7	SCREW	4
23	201002	スプリングピン	PIN	2
24	210003	栓	PLUG	1
25	208173	栓	PLUG	1
26	210003	栓	PLUG	1
27	210005	送リ調節蓋	COVER PLATE	1
28	5117	平ネジ / C 5 × 8.5	SCREW	6
29	210583	チューブ	PIPE	1
30	202526	配銘板	NAME PLATE	1
31	212279A	形式板	TYPE PLATE	1
32	210679	止ピン	PIN	4
33	204006	足ピン	BED PIN	4
34	230047A	機番板	SERIAL NUMBER PLATE	1
35	8421	オイルマーク	OIL MARK	1
36	208173	栓	PLUG	1
37	209084	蓋	PLUG	1
38	210003	栓	PLUG	1
39	208173	栓	PLUG	1
40	4009-1	平ネジ / C 5 × 7.5	SCREW	1
41	202047	給油フェルト	OIL FELT	1

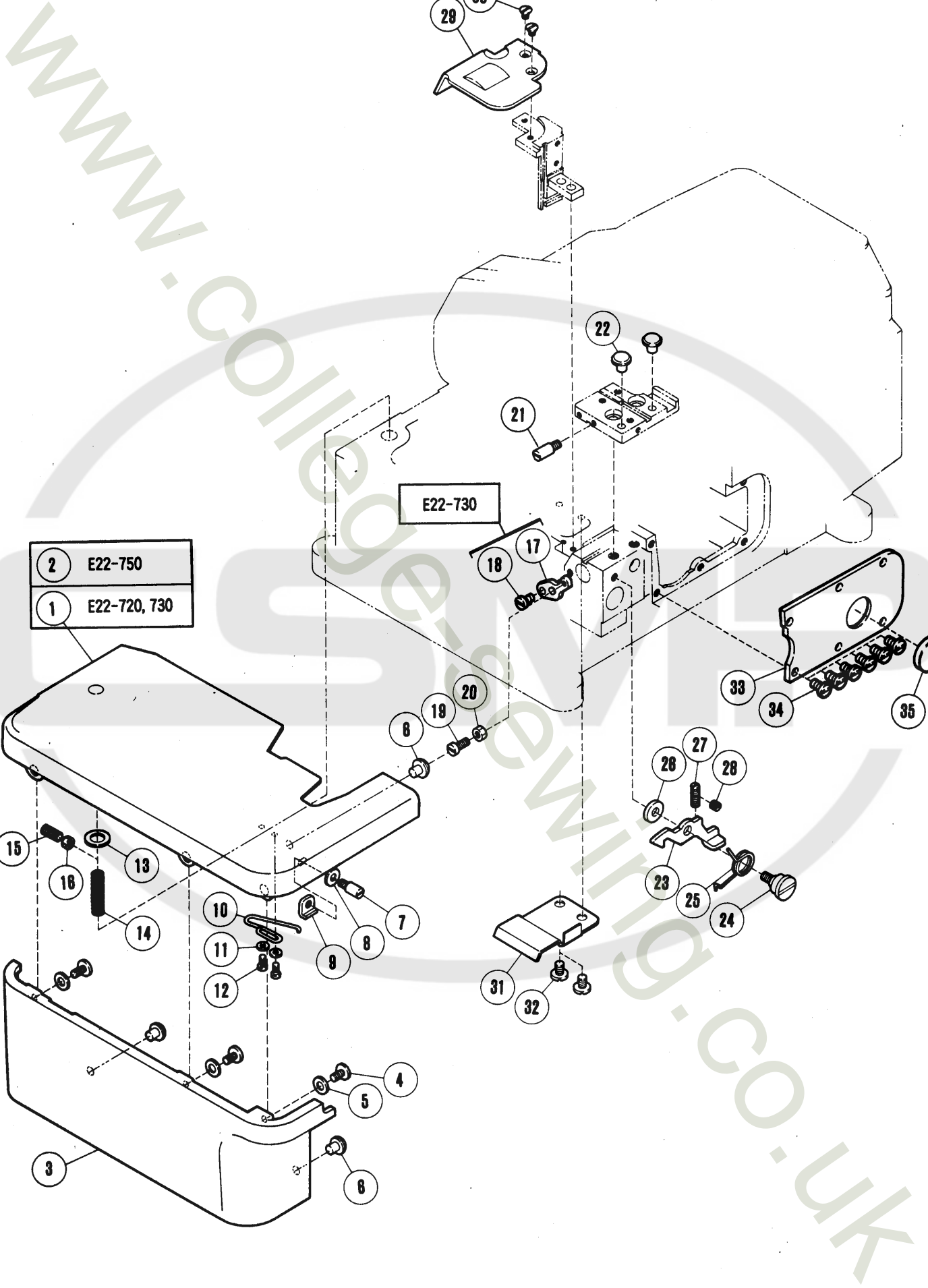

2	E22-750
1	E22-720, 730

E22-730

カバ-機構(1)

COVER (1)

REF. NO.	PART NO. 部品番号	名称	NAME	QT.
1	211977	クロスプレート	CLOTH PLATE	1
2	210883	クロスプレート (広巾)	CLOTH PLATE(WIDE)	1
3	210027-FB	横カバ- (広巾)	SIDE COVER (WIDE)	1
4	4009-1	平ネジ / C 5 × 7. 5	SCREW	3
5	201185	座金	WASHER	3
6	210025	振動止メ	CUSHION	3
7	210022	ピン付ネジ / C 4	SCREW	1
8	137906	座金	WASHER	1
9	211300	四角ナット / C 4	NUT	1
10	210024	繊細工バネ	SPRING	1
11	202875	座金	WASHER	2
12	5012	平ネジ / C 3 × 5. 5	SCREW	2
13	210020	座金	WASHER	1
14	192130	圧縮バネ	SPRING	1
15	5483	止ネジ / C 3 × 1 2	SCREW	1
16	3044	六角ナット / C 5	NUT	1
17	210183	下メスバネ受ケ	SPRING RETAINER	1
18	5117	平ネジ / C 5 × 8. 5	SCREW	1
19	1174	平ネジ / C 4 × 9. 5	SCREW	1
20	3091	六角ナット / C 4	NUT	1
21	210022	ピン付ネジ / C 4	SCREW	1
22	210025	振動止メ	CUSHION	2
23	210021	ラッチ	LATCH	1
24	5488	段付ネジ / C 5	SCREW	1
25	210023	ネジリバネ	SPRING	1
26	208245	座金	WASHER	1
27	1435	止ネジ / C 5 × 1 2. 7	SCREW	1
28	1459	止ネジ / C 4 × 3	SCREW	1
29	210006	送りエキセンカバ-	COVER/FEED ECCENTRIC	1
30	5480	皿ネジ / C 3 × 3. 9	SCREW	2
31	210007	カバ- / 送り台	FEED BAR COVER	1
32	2905	平ネジ / C 5 × 4. 5	SCREW	2
33	210117	上ル-バ-台カバ-	UPPER LOOPER HOLDER COVER	1
34	4009-1	平ネジ / C 5 × 7. 5	SCREW	6
35	211247	栓	PLUG	1

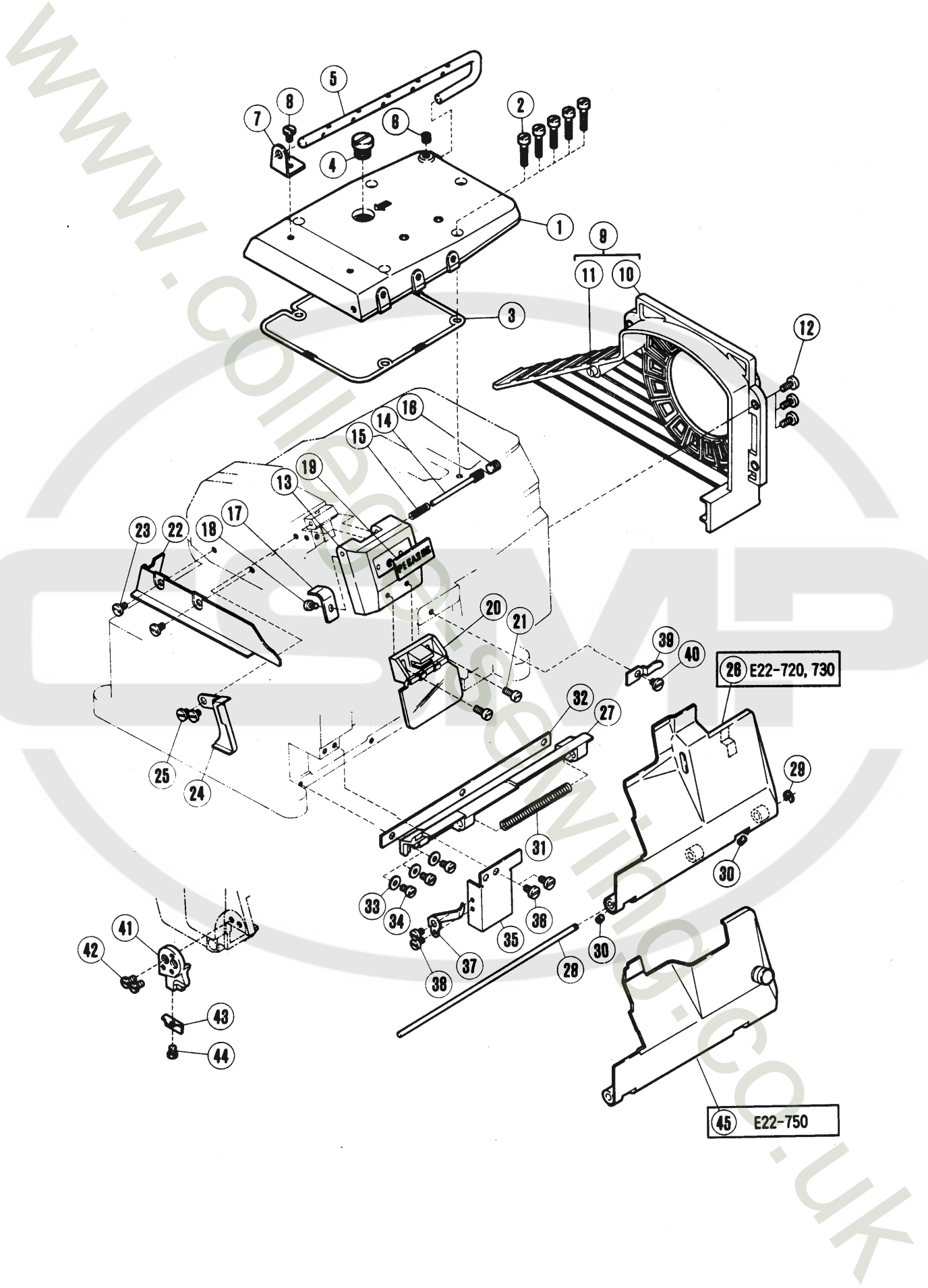

カバー機構(2)

COVER (2)

REF. NO.	PART NO. 部品番号	名称	NAME	QT.
1	210034-HD	上カバー	TOP COVER	1
2	5095	平ネジ / C 5 × 1 9	SCREW	5
3	210035	Oリング	O RING	1
4	5198	平ネジ / C 1 4 × 1 0	SCREW	1
5	210036	糸道棒	THREAD GUIDE BAR	1
6	5060	止ネジ / C 8 × 4 . 5	SCREW	1
7	210037	ブラケット	BRACKET	1
8	4009-1	平ネジ / C 5 × 7 . 5	SCREW	1
9	210028-FB	ベルトカバー	BELT COVER	1
10	212955-FB	ベルトカバー - 本体	BELT COVER	1
11	200697	当ゴム	CUSHION RUBBER	1
12	5117	平針糸カバー	SCREW	3
13	211959-HD	針糸付ネジ / C 8	NEEDLE THREAD COVER	1
14	5589	段圧縮バネ	SCREW	1
15	211958	圧縮バネ	SPRING	1
16	5060	止ネジ / C 8 × 4 . 5	SCREW	1
17	210223	板バネ	FLAT SPRING	1
18	1216	平ネジ / C 4 × 5 . 5	SCREW	1
19	205722	銘板	NAME PLATE	1
20	208747	安全カバー (組)	EYE GUARD COMPLETE	1
21	1175-3	平ネジ / C 4 × 1 0	SCREW	2
22	210224	布案内	FABRIC GUARD	1
23	4009-1	平ネジ / C 5 × 7 . 5	SCREW	2
24	210221	カバー (A) / アーム左	COVER/MACHINE ARM LEFT	1
25	2905	平ネジ / C 5 × 4 . 5	SCREW	2
26	211855	前カバー (組)	FRONT COVER ASSEMBLY	1
27	210042	ヒンジ / 前カバー	HINGE/FRONT COVER	1
28	208009	平行ピン	PIN	1
29	200555	止メ輪	RING	1
30	5292	止ネジ / C 3 × 2 . 7	SCREW	2
31	210043	圧縮バネ	SPRING	1
32	210047	ガスケット	GASKET	1
33	137906	座金	WASHER	3
34	1202	平ネジ / C 4 × 7	SCREW	3
35	210046	案内 / 前カバー	GUIDE/FRONT COVER	1
36	4009-1	平ネジ / C 5 × 7 . 5	SCREW	2
37	210045	板バネ	FLAT SPRING	1
38	1216	平ネジ / C 4 × 5 . 5	SCREW	2
39	210044	板バネ	FLAT SPRING	1
40	2905	平ネジ / C 5 × 4 . 5	SCREW	1
41	211389	カバー (B) / アーム左	COVER/MACHINE ARM LEFT	1
42	5328	平ネジ / C 4 × 6 . 3	SCREW	2
43	212984	カバー	COVER	1
44	5053	平ネジ / C 4 × 4 . 8	SCREW	1
45	212636	前カバー	FRONT COVER	1

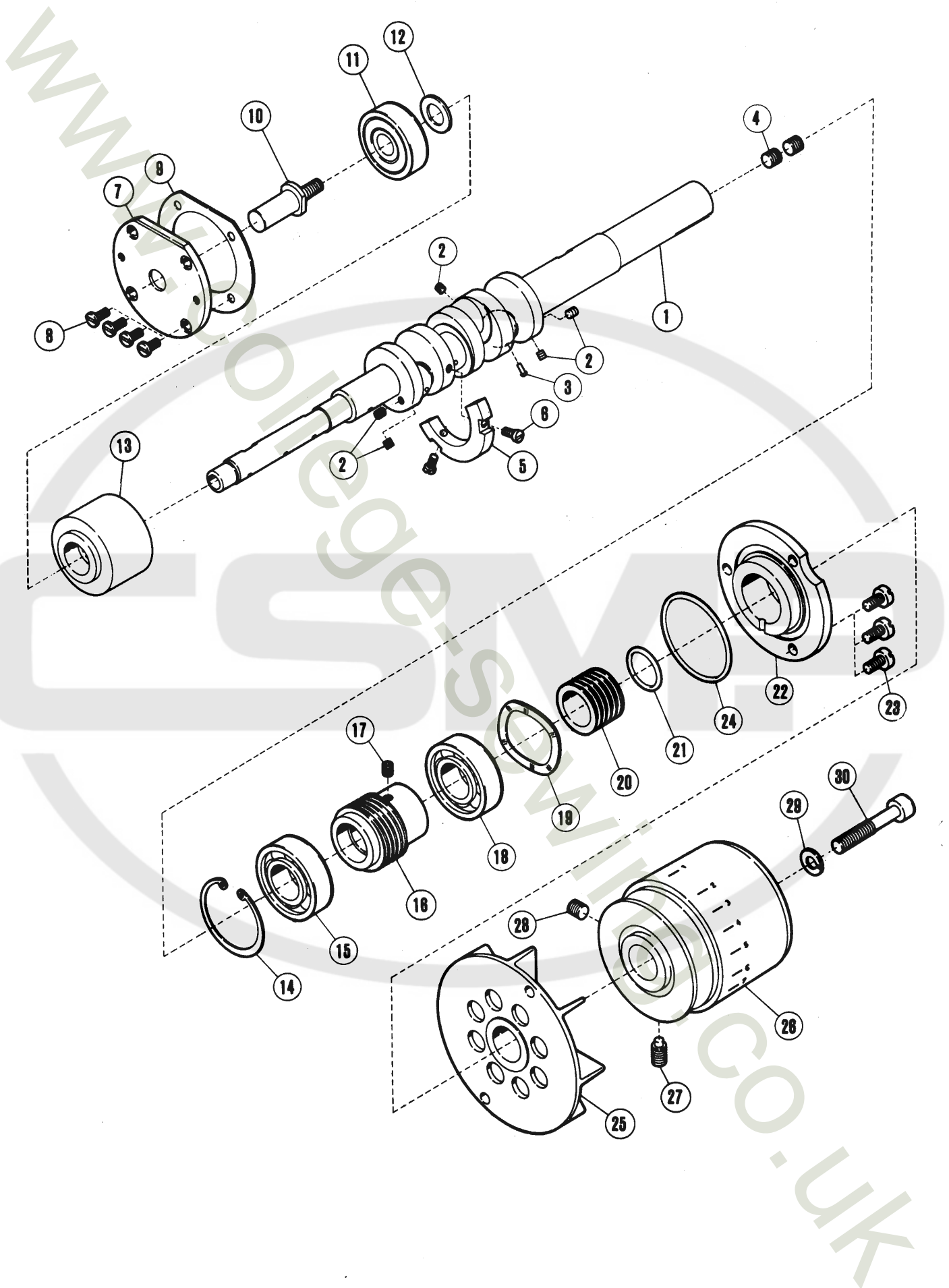

クランクシャフト機構

CRANKSHAFT DRIVE MECHANISM

REF. NO.	PART NO. 部品番号	名称	NAME	QT.
1	210228-PB	クランクシャフト	CRANKSHAFT	1
2	1459	止ネジ / C 4 × 3	SCREW	5
3	208627	栓	OIL PLUG	1
4	1448	止ネジ / C 9 × 5 . 2	SCREW	2
5	210062	バランスウエイト	BALANCE WEIGHT	1
6	5029	平ネジ / C 3 × 7 . 5	SCREW	2
7	204881	ハウジング	HOUSING	1
8	5328	平ネジ / C 4 × 6 . 3	SCREW	4
9	204319	ガスケット	GASKET	1
10	204873	段付ピン	CRANK SHAFT EXTENSION	1
11	204010	ボールベアリング	BUSHING	1
12	240102	座金	WASHER	1
13	211533	ブッシュ	BUSHING	1
14	211527	止メ輪	RING	1
15	212987	ボールベアリング	BALL BEARING	1
16	211530	ウォーム	WORM	1
17	5461	止ネジ / C 5 × 5	SCREW	1
18	211526	ボールベアリング	BALL BEARING	1
19	211529	波板座金	WASHER	1
20	210056	油切り	OIL SEAL	1
21	210057	Oリング	O RING	1
22	211528	ハウジング	BALL BEARING RETAINER	1
23	5117	平ネジ / C 5 × 8 . 5	SCREW	3
24	210055	Oリング	O RING	1
25	210058	ファン	COOLING FAN	1
26	211345AHD	プーリー	MACHINE PULLEY	1
27	5523	止ネジ / C 9 × 1 1 . 5	SCREW	1
28	5050	止ネジ / C 9 × 7	SCREW	1
29	204293	バネ座金	SPRING WASHER	1
30	5522	平ネジ / C 9 × 3 3 . 5	SCREW	1

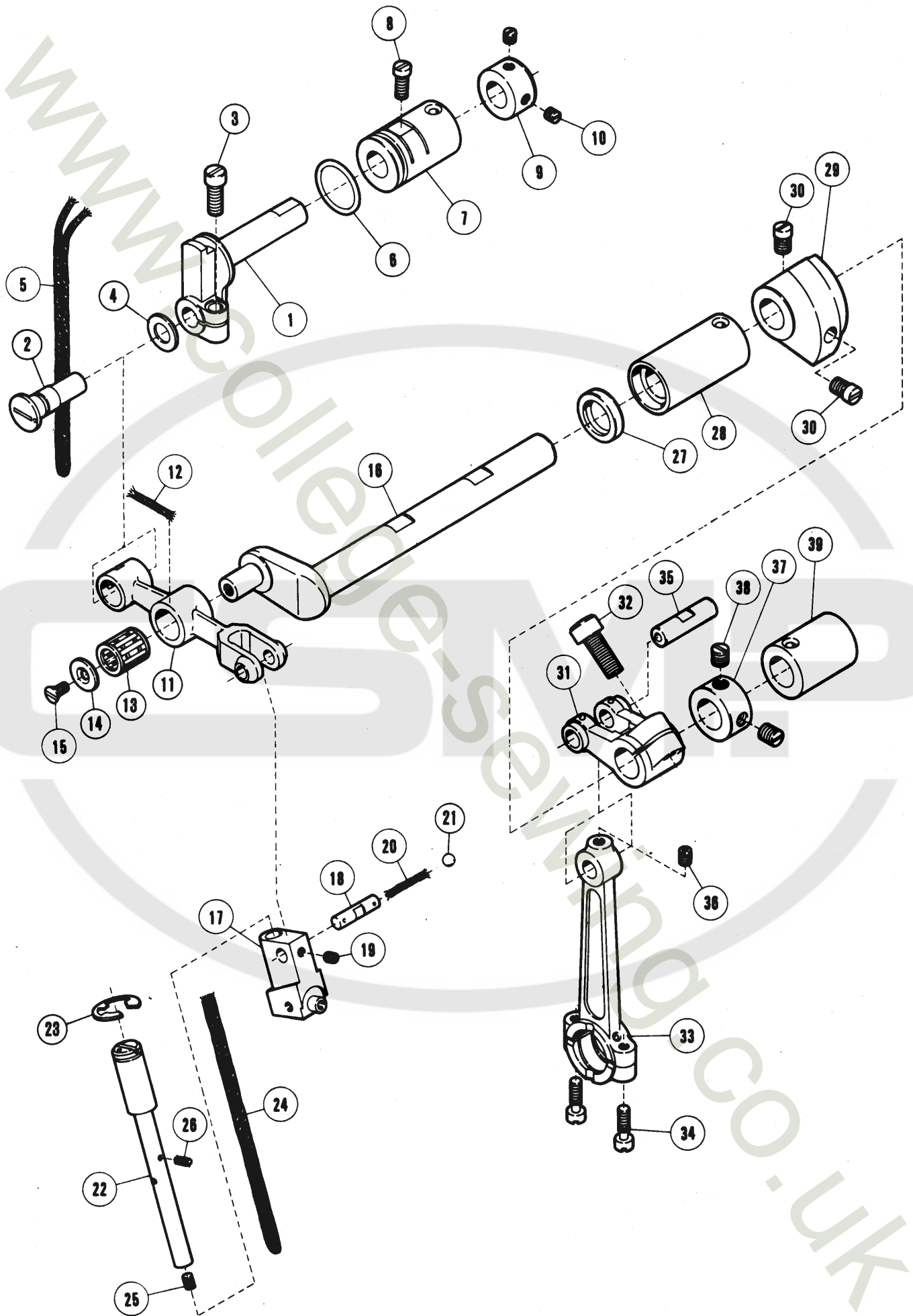

針振り機構(1)

NEEDLE DRIVE MECHANISM (1)

REF. NO.	PART NO. 部品番号	名称	NAME	QT.
1	210239	針振り案内	HOLDER	1
2	210240	エキセンピン	PIN	1
3	5485	平ネジ / C 7 × 1 2 . 5	SCREW	1
4	210241	座金	WASHER	1
5	212186	給油紐	OIL WICK	1
6	210057	Oリング	O RING	1
7	210242	ブッシュ	BUSHING	1
8	2133-1	平ネジ / C 5 × 1 2 . 5	SCREW	1
9	201056	カラージ	COLLAR	1
10	1457	止ネジ / C 5 × 4	SCREW	2
11	210235	レバー / 針振り	LEVER/NEEDLE DRIVE	1
12	202175	給油紐	OIL WICK	1
13	210238	ニードルベアリング	NEEDLE BEARING	1
14	210236	座金	WASHER	1
15	5022	皿ネジ / C 3 × 6 . 3	SCREW	1
16	210232A	軸 / 針振り	SHAFT/NEEDLE DRIVE	1
17	210243	針留案内	NEEDLE HOLDER GUIDE	1
18	210237A	平行ピン	PIN	1
19	5292	止ネジ / C 3 × 2 . 7	SCREW	1
20	202175	給油紐	OIL WICK	1
21	240148	栓	PLUG	1
22	210244	軸 / 針留案内	SHAFT	1
23	202577	止メ輪	RING	1
24	202176	給油紐	OIL WICK	1
25	5292	止ネジ / C 3 × 2 . 7	SCREW	1
26	202174	給油紐	OIL WICK	1
27	210069	オイルシール	OIL SEAL	1
28	210234	ブッシュ	BUSHING	1
29	210511	バランスウェイト	BALANCE WEIGHT	1
30	5059	平ネジ / C 8 × 6 . 5	SCREW	2
31	210230	クランク / 針	CRANK/NEEDLE DRIVE	1
32	5457	平ネジ / C 9 × 1 5	SCREW	1
33	210229	口ツド / 針振り	CONNECTION/NEEDLE DRIVE	1
34	5376	平ネジ / C 4 × 1 2 . 5	SCREW	2
35	204146	平行ピン	PIN	1
36	5461	止ネジ / C 5 × 5	SCREW	1
37	201635	カラージ	COLLAR	1
38	5060	止ネジ / C 8 × 4 . 5	SCREW	2
39	210233	ブッシュ	BUSHING	1

WWW.CSILK

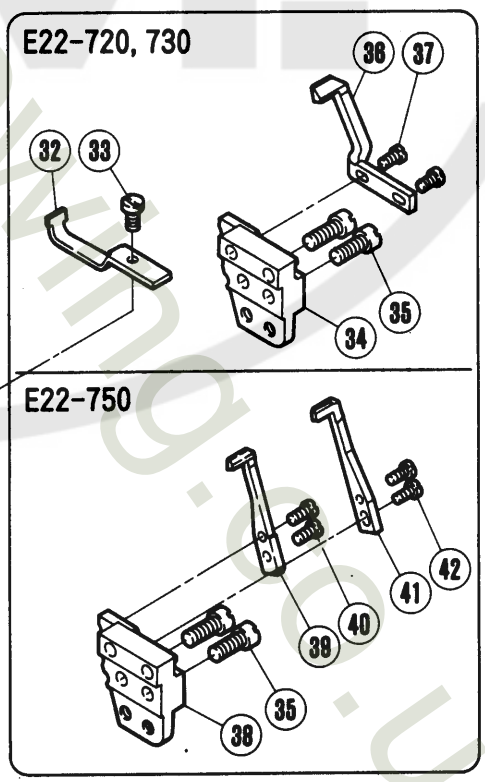
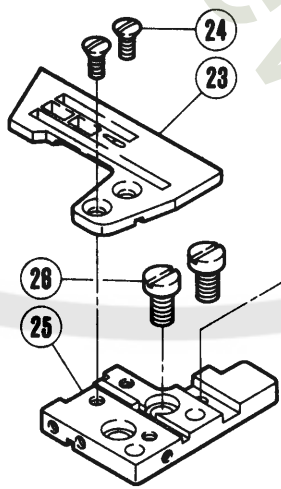
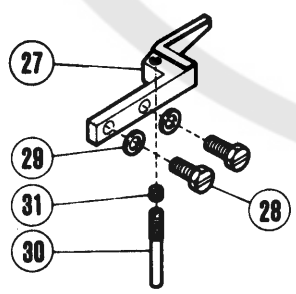
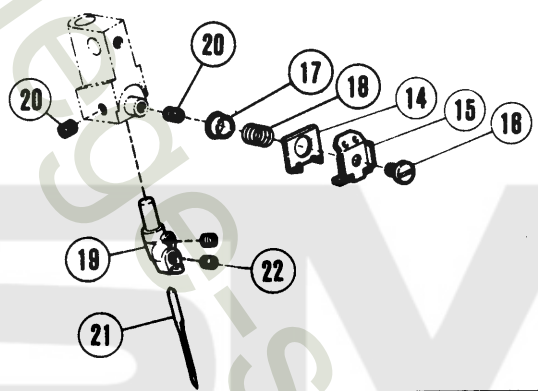
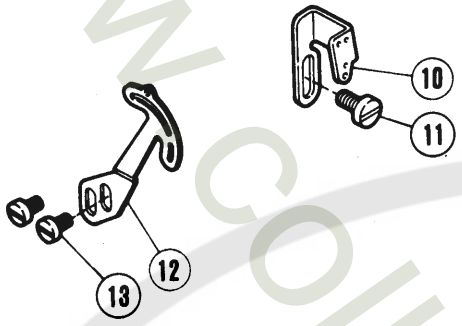
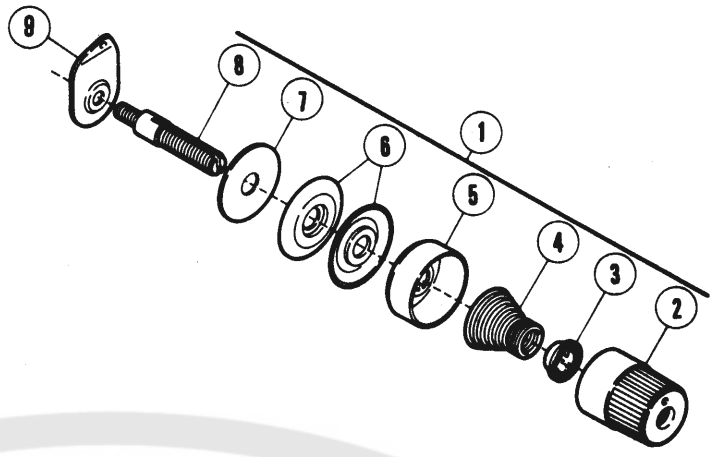

針振り機構(2)

NEEDLE DRIVE MECHANISM (2)

REF. NO.	PART NO. 部品番号	名称	NAME	QT.
1	210529	糸調子(組)(強)	THREAD TENSION COMPLETE	1
2	208447	調子ナット	POST NUT	1
3	208448	ラチエット	SPRING BUSHING	1
4	201037	圧縮バネ(強)	SPRING (HEAVY)	1
5	208450	受皿	CUP	1
6	210319	調子皿	TENSION DISC	2
7	208449	フェルト	FELT	1
8	5082A	調子棒 / C 5	SCREW STUD	1
9	202849	調子台	TENSION GUIDE	1
10	210264	糸道 / 針糸(右)	THREAD GUIDE	1
11	5117	平ネジ / C 5 × 8 . 5	SCREW	1
12	211398	糸繰リ / 針糸	THREAD TAKEUP	1
13	1175-3	平ネジ / C 4 × 1 0	SCREW	2
14	210749	小調子皿	NEEDLE THREAD RETAINER	1
15	210260	小調子台	BRACKET	1
16	1229	平ネジ / C 3 × 4 . 5	SCREW	1
17	210750	案内	GUIDE	1
18	210751	圧縮バネ	SPRING	1
19	XXXXXX	針留	NEEDLE HOLDER	1
20	5292	止ネジ / C 3 × 2 . 7	SCREW	2
21	XXXXXX	針	NEEDLE	1
22	5292	止ネジ / C 3 × 2 . 7	SCREW	1
23	XXXXXX	針板	NEEDLE PLATE	1
24	5484-HC	皿ネジ / C 5 × 8	SCREW	2
25	211392	針板ブラケット(組)	BRACKET COMPLETE	1
26	5357	平ネジ / C 9 × 1 1	SCREW	2
27	210922	針板受(組)	SUPPORT COMPLETE/NEEDLE PLATE	1
28	5501	六角ネジ / C 4 × 9 . 5	SCREW	2
29	210898	バネ座金	WASHER	2
30	210923	ピン付ネジ / C 4	SCREW	1
31	1459	止ネジ / C 4 × 3	SCREW	1
32	210278	針受(前) / 二重環	CHAINSTITCH NEEDLE GUARD FRONT	1
33	5328	平ネジ / C 4 × 6 . 3	SCREW	1
34	210277A	ブラケット / 針受	BRACKET	1
35	5002	平ネジ / C 5 × 1 0 . 5	SCREW	2
36	210279	針受(後) / 二重環	CHAINSTITCH NEEDLE GUARD REAR	1
37	5492	平ネジ / C 1 × 6	SCREW	2
38	210277	ブラケット / 針受	BRACKET/NEEDLE GUARD	1
39	212638	針受(前)	NEEDLE GUARD (FRONT)	1
40	5492	平ネジ / C 1 × 6	SCREW	2
41	212639	針受(後)	NEEDLE GUARD (REAR)	1
42	5492	平ネジ / C 1 × 6	SCREW	2

注:「XXXXXX」はゲージパーツです。

44頁を参照してください。

PLEASE NOTE:「XXXXXX」 is one of the gauge parts.

So please refer to page 44 and confirm the correct parts.

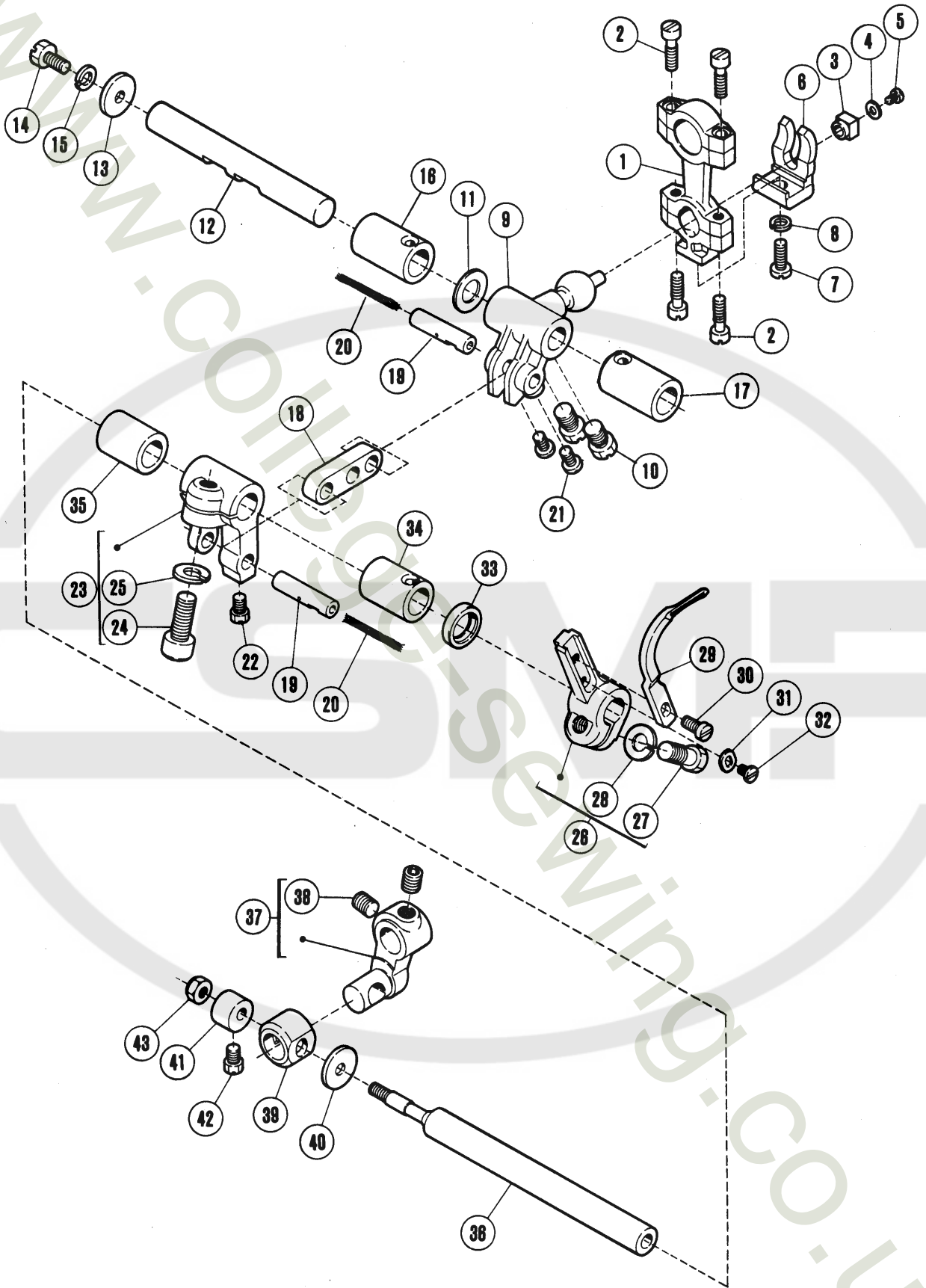

REF. NO.	PART NO.	名称	NAME	QT.
1	210091	口ッド	CONNECTION	1
2	5376	平ネジ / C 4 × 1 2 . 5	SCREW	4
3	210093	角駒	BLOCK	1
4	210585	座金	WASHER	1
5	1231	平ネジ / C 1 × 3 . 4	SCREW	1
6	210092	振レ止メ	GUIDE/CONNECTION	1
7	5546	平ネジ / C 5 × 1 0	SCREW	1
8	202286	バネ座金	SPRING WASHER	1
9	210736	クラック / 下ルーパー	CRANK/LOWER LOOPER DRIVE	1
10	2022-4	六角ネジ / C 1 0 × 9	SCREW	2
11	240102	座金	WASHER	1
12	208582	クラック軸	CRANKSHAFT	1
13	204107	座金	WASHER	1
14	2193	六角ネジ / C 5 × 8 . 5	SCREW	1
15	202286	バネ座金	SPRING WASHER	1
16	210125	ブッシュ	BUSHING	1
17	210124	ブッシュ	BUSHING	1
18	208194	リンク / ルーパー振り	LINK/LOOPER DRIVE	1
19	208195	平行ピン	PIN	2
20	202176	給油紐	OIL WICK	2
21	5328	平ネジ / C 4 × 6 . 3	SCREW	2
22	5084	六角ネジ / C 5 × 5 . 5	SCREW	1
23	210294	クラック / ルーパー振り	CRANK/LOOPER DRIVE	1
24	5457	平ネジ / C 9 × 1 5	SCREW	1
25	204293	バネ座金	SPRING WASHER	1
26	210298	ルーパー台	LOOPER HOLDER	1
27	5487	六角ネジ / C 9 × 1 4 . 5	SCREW	1
28	204293	バネ座金	SPRING WASHER	1
29	210357	二重環ルーパー	DOUBLE CHAINSTITCH LOOPER	1
30	1175-2	平ネジ / C 4 × 8	SCREW	1
31	210299	調節金	REGULATOR	1
32	2922	平ネジ / C 1 × 5 . 5	SCREW	1
33	210586	オイルシール	OIL SEAL	1
34	210296	ブッシュ	BUSHING	1
35	210297	ブッシュ	BUSHING	1
36	208196	軸 / ルーパー振り	SHAFT/LOOPER DRIVE	1
37	210288	レバー / ルーパー前後	LEVER/LOOPER AVOIDING	1
38	5461	止ネジ / C 5 × 5	SCREW	2
39	210289	角駒 / ルーパー前後	BLOCK	1
40	208028	座金	WASHER	1
41	208029	カラー	COLLAR	1
42	5084	六角ネジ / C 5 × 5 . 5	SCREW	1
43	4802	六角ナット / M 4	NUT	1

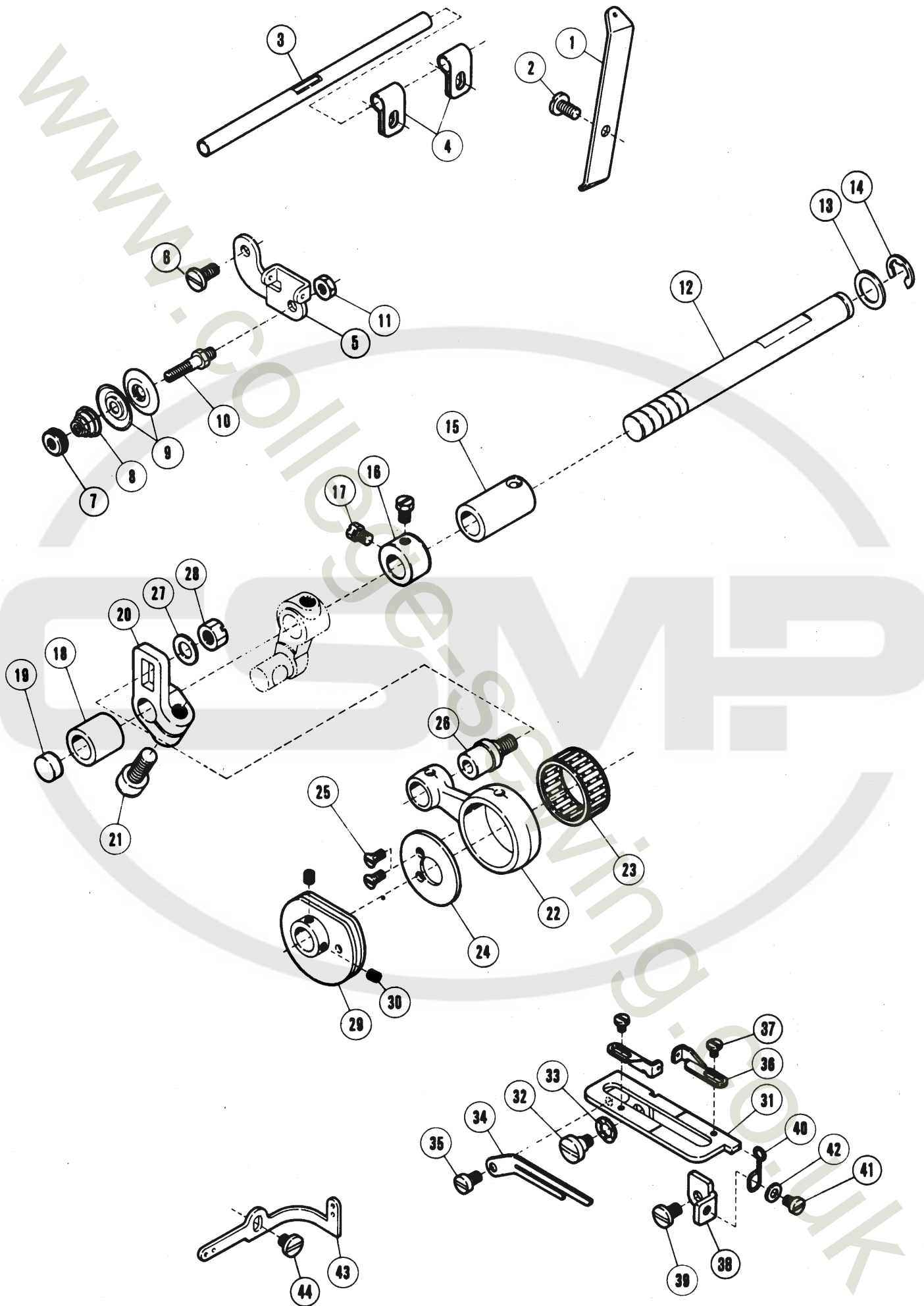

REF. NO.	PART NO. 部品番号	名称	NAME	QT.
1	210309	糸道 / ルーパー (後)	THREAD GUIDE	1
2	4009-1	平ネジ / C 5 × 7 . 5	SCREW	1
3	210310	糸道パイプ	THREAD TUBE	1
4	206115	ホルダー	HOLDER	2
5	211386	糸調子台	THREAD GUIDE	1
6	5117	平ネジ / C 5 × 8 . 5	SCREW	1
7	5526	丸ナット / C 4	NUT	1
8	211388	圧縮バネ	SPRING	1
9	137108	調子皿	TENSION DISC	2
10	211387	糸調子棒	TENSION POST	1
11	3044	六角ナット / C 5	NUT	1
12	212654	軸 / ルーパー 前後	SHAFT/LOOPER AVOIDING	1
13	240102	座金	WASHER	1
14	205061	止メ輪	RING	1
15	252005	ブッシュ	BUSHING	1
16	210293	カラー	COLLAR	1
17	5084	六角ネジ / C 5 × 5 . 5	SCREW	2
18	210292	ブッシュ	BUSHING	1
19	205088	栓	PLUG	1
20	210287	クランク / ルーパー 前後	CRANK/LOOPER AVOIDING	1
21	5457	平ネジ / C 9 × 1 5	SCREW	1
22	210284	口ド / ルーパー 前後	CONNECTION/LOOPER AVOIDING	1
23	205015	ニードルベアリング	NEEDLE BEARING	1
24	210283	カラ	COLLAR	1
25	5259	皿ネジ / C 1 × 5 . 2	SCREW	2
26	210285	段付ピン	PIN	1
27	202433	座金	WASHER	1
28	5455	六角ナット / C 8	NUT	1
29	210300	糸繰り / ルーパー	THREAD TAKEUP	1
30	5292	止ネジ / C 3 × 2 . 7	SCREW	2
31	210304	ルーパー糸繰り台	BRACKET/LOOPER THREAD GUIDE	1
32	5494	段付ネジ / C 5	SCREW	1
33	210307	波板座金	WASHER	1
34	210302	糸繰り案内	GUIDE/THREAD TAKEUP	1
35	1216	平ネジ / C 4 × 5 . 5	SCREW	1
36	210303	糸道 / ルーパー糸繰り	THREAD GUIDE	2
37	5077	平ネジ / C 1 × 3	SCREW	2
38	210308	ストッパー	STOPPER	1
39	5453	平ネジ / C 5 × 6 . 5	SCREW	1
40	210306	線細工バネ	SPRING	1
41	1234	平ネジ / C 4 × 3 . 8	SCREW	1
42	137906	座金	WASHER	1
43	210311	糸道	THREAD GUIDE	1
44	4009-1	平ネジ / C 5 × 7 . 5	SCREW	1

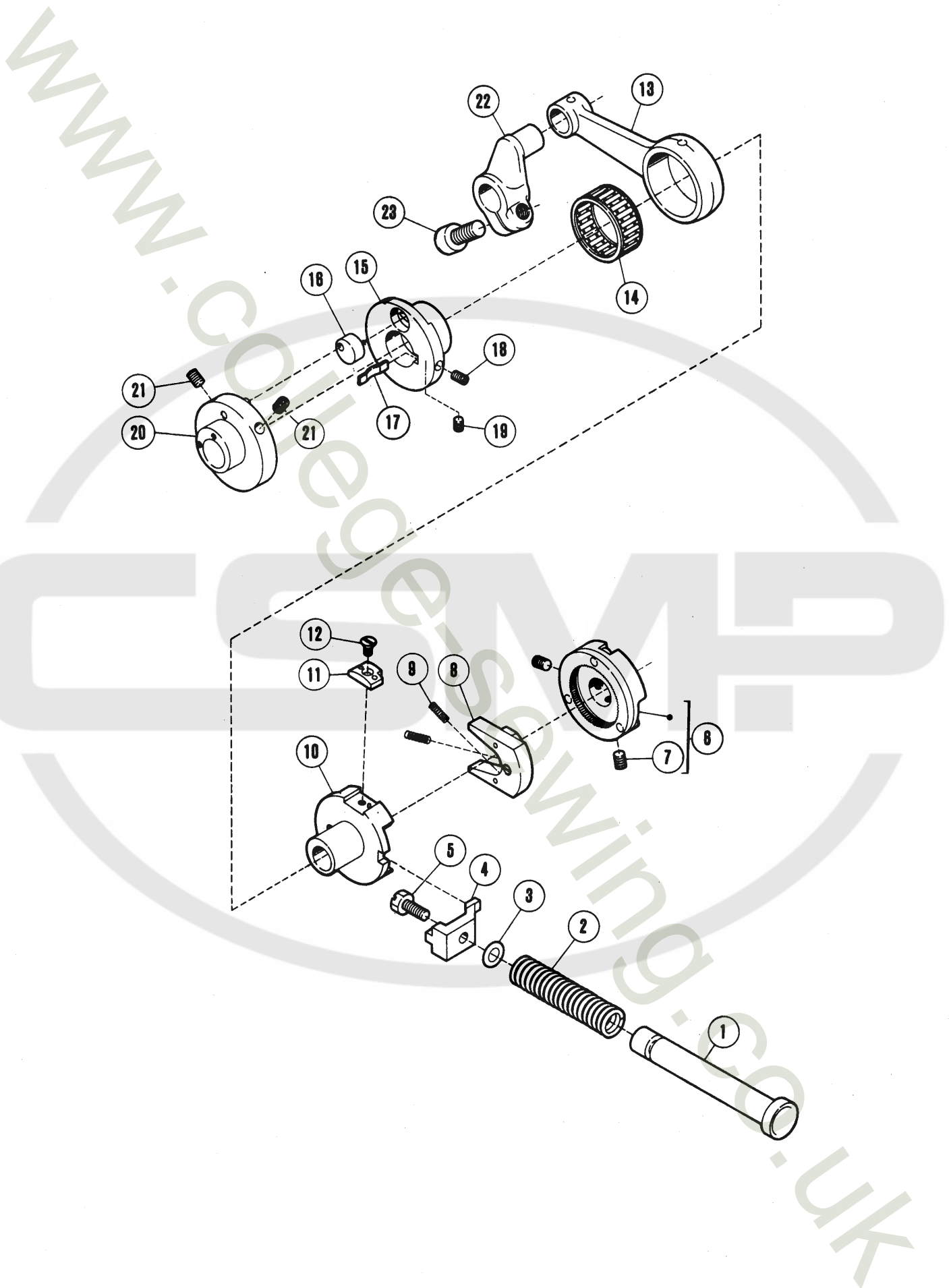

送り機構(1)

FEED MECHANISM (1)

REF. NO.	PART NO. 部品番号	名称	NAME	QT.
1	210137	プッシュボタン	PUSH BUTTON	1
2	210139	圧縮バネ	SPRING	1
3	204185	Oリング	O RING	1
4	210138	ストッパ	STOPPER	1
5	2193	六角ネジ / C 5 × 8 . 5	SCREW	1
6	210136	ラチェットホイール (組)	RATCHET WHEEL COMPLETE	1
7	5461	止ネジ / C 5 × 5	SCREW	2
8	208411	エキセン調節器 (爪) 組	FEED REGULATING RATCHET	1
9	208415	圧縮バネ	SPRING	2
10	211802A	エキセン / 送り調節	ECCENTRIC/FEED REGULATING	1
11	211804	ストッパ	STOPPER	1
12	5437	皿ネジ / C 3 × 5 . 5	SCREW	1
13	210140	送りロッド	CONNECTION/FEED DRIVE	1
14	204084	ニードルベアリング	NEEDLE BEARING	1
15	210127	送りエキセン	ECCENTRIC/FEED DRIVE	1
16	210129	案内 / 送りエキセン	GUIDE/FEED ECCENTRIC	1
17	210130	板バネ	FLAT SPRING	1
18	5427	止ネジ / C 3 × 5 . 5	SCREW	1
19	5292	止ネジ / C 3 × 2 . 7	SCREW	1
20	210282A	エキセン / ルーパー前後	ECCENTRIC/LOOPER AVOIDING	1
21	5461	止ネジ / C 5 × 5	SCREW	2
22	210141	送りクランク	CRANK/FEED DRIVE	1
23	5457	平ネジ / C 9 × 1 5	SCREW	1

E22-730

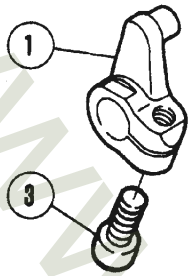

E22-720
E22-750

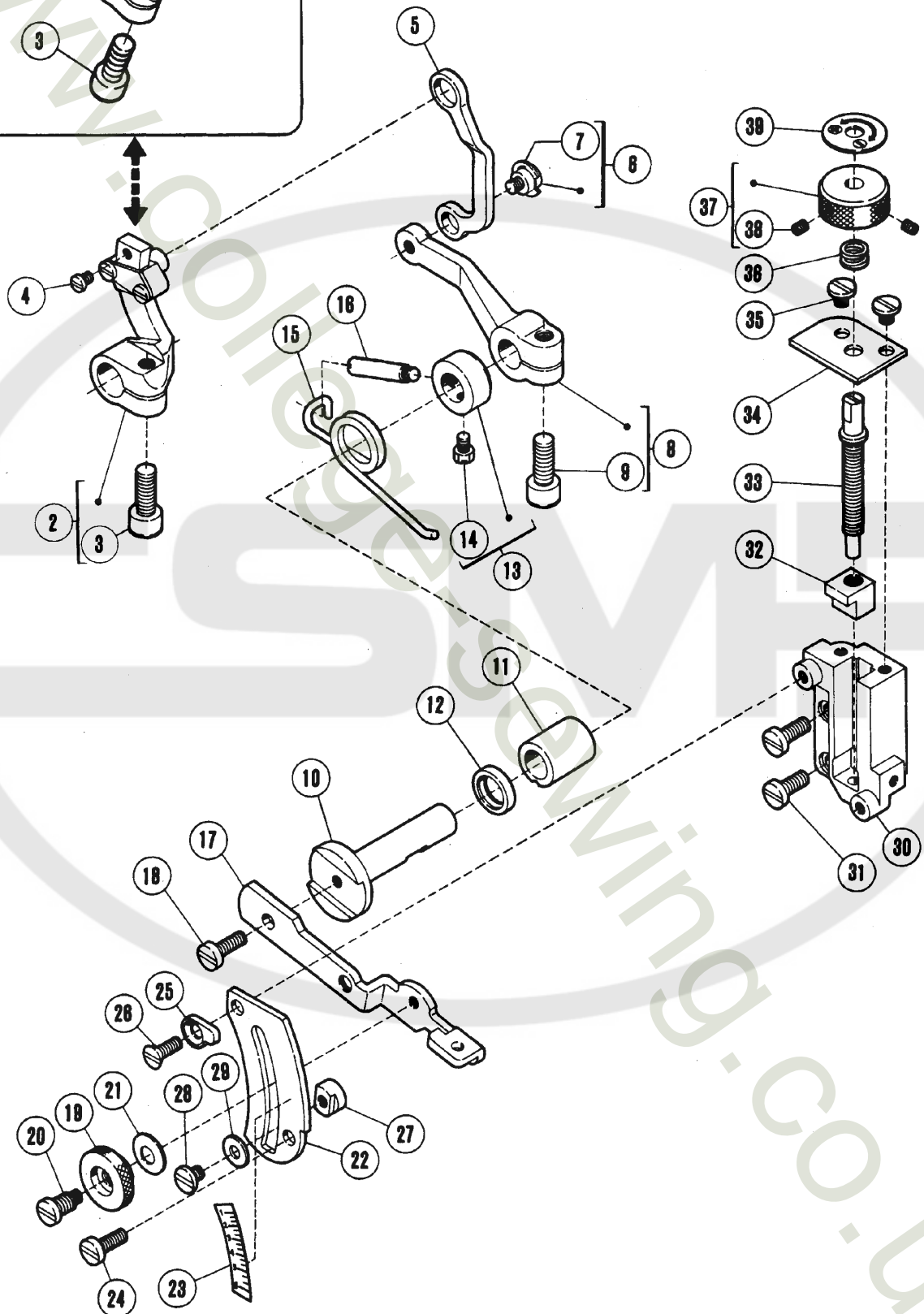

送り機構(2)

FEED MECHANISM (2)

REF. NO.	PART NO. 部品番号	名称	NAME	QT.
1	209059	クランク / 差動送り	CRANK/DIFFERENTIAL FEED	1
2	210152	クランク (組) / 差動送り	CRANK COMPLETE/DIFF. FEED	1
3	5457	平ネジ / C 9 × 1.5	SCREW	1
4	5346	平ネジ / C 3 × 4.2	SCREW	1
5	210161	リンク / 差動調節	LINK/DIFF. FEED REGULATING	1
6	5316	段付ネジ / C 5	SCREW	1
7	202522	止メ輪	RING	1
8	210162	レバー / 差動調節	LEVER/DIFF. FEED REGULATING	1
9	5457	平ネジ / C 9 × 1.5	SCREW	1
10	210163	軸 / 差動調節	SHAFT/DIFF. FEED REGULATING	1
11	210164	ブッシュ	BUSHING	1
12	204052A	オイルシール	OIL SEAL	1
13	204754A	オカラ	COLLAR	1
14	5084	六角ネジ / C 5 × 5.5	SCREW	1
15	204756	ネジリバネ	SPRING	1
16	204757	段付ピン	PIN	1
17	210166	レバー / 差動調節 (左)	LEVER/DIFF. FEED REGULATING	1
18	5117	平ネジ / C 5 × 8.5	SCREW	1
19	210167	ツマミ	THUMB NUT	1
20	5486	段付ネジ / C 5	SCREW	1
21	211301	皿バネ	SPRING WASHER	1
22	210168	案内 / 差動調節	REGULATING PLATE/DIFF. FEED	1
23	210170	目盛板	INDICATION PLATE	1
24	5117	平ネジ / C 5 × 8.5	SCREW	1
25	210700	ストッパ	STOPPER	1
26	1732	皿ネジ / C 5 × 10.5	SCREW	1
27	210171	ストッパ	STOPPER	1
28	2905	平ネジ / C 5 × 4.5	SCREW	1
29	201185	座金	WASHER	1
30	211314	差動調節台	REGULATING BASE/DIFF. FEED	1
31	5118	平ネジ / C 5 × 1.2	SCREW	2
32	210535	角駒 / 差動調節	BLOCK/DIFF. FEED REGULATING	1
33	210172	差動調節棒	REGULATING BAR/DIFF. FEED	1
34	210534	案内 / 差動調節棒	GUIDE/DIFF. FEED REG. BAR	1
35	5091	平ネジ / C 5 × 7.5	SCREW	2
36	210533	圧縮バネ	SPRING	1
37	210532	ツマミ	THUMB NUT	1
38	5292	止ネジ / C 3 × 2.7	SCREW	2
39	212179	標示板	MARK	1

WWW.KUN

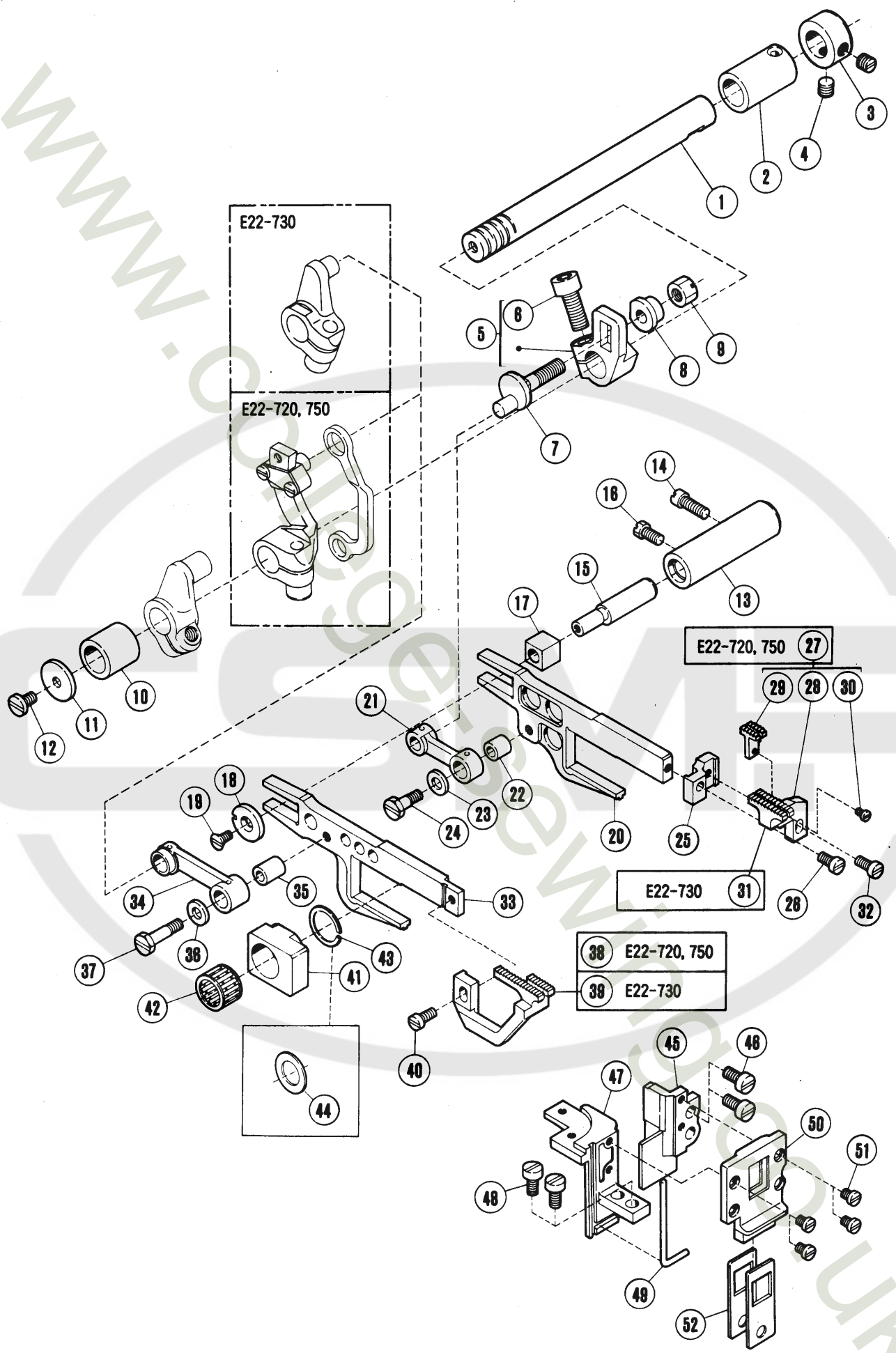

送り機構(3)

FEED MECHANISM (3)

REF. NO.	PART NO. 部品番号	名称	NAME	QT.
1	210142	軸 / 送り	FEED SHAFT	1
2	210102	ブッシュ	BUSHING	1
3	201635	カラ	COLLAR	1
4	5060	止ネジ / C 8 × 4 . 5	SCREW	2
5	210144	クラック / 主送り	CRANK/MAIN FEED	1
6	5457	平ネジ / C 9 × 1 5	SCREW	1
7	210145	エキセンピン	PIN	1
8	210146	座金	WASHER	1
9	5455	六角ナット / C 8	NUT	1
10	210143	ブッシュ	BUSHING	1
11	210100	座金	WASHER	1
12	4009-1	平ネジ / C 5 × 7 . 5	SCREW	1
13	204129A	送り台案内軸	BUSHING	1
14	2133-1	平ネジ / C 5 × 1 2 . 5	SCREW	1
15	204128A	段付ピン	PIN	1
16	5084	六角ネジ / C 5 × 5 . 5	SCREW	1
17	205418	角駒 / 送り台案内	BLOCK/FEED BAR GUIDE	1
18	204439A	座金	WASHER	1
19	5317	皿ネジ / C 3 × 6	SCREW	1
20	210154	主送り台	MAIN FEED BAR	1
21	210147	リンク / 主送り	LINK/MAIN FEED	1
22	210148	ブッシュ	BUSHING	1
23	204115	座金	WASHER	1
24	5489	六角ネジ / C 5 × 1 2 . 5	SCREW	1
25	210343	ブラケット / 主送り歯	BRACKET/MAIN FEED DOG	1
26	1175-2	平ネジ / C 4 × 8	SCREW	1
27	XXXXXX	主送り歯 (組)	MAIN FEED DOG COMPLETE	1
28	XXXXXX	主送り歯	MAIN FEED DOG	1
29	XXXXXX	補助送り歯	AUXILIARY FEED DOG	1
30	5492	平ネジ / C 1 × 6	SCREW	1
31	211858	送り歯 (右)	FEED DOG (RIGHT)	1
32	5590	段付ネジ / C 4	SCREW	1
33	210155	差動送り台	DIFFERENTIAL FEED BAR	1
34	210153	リンク / 差動送り	LINK/DIFFERENTIAL FEED	1
35	204114	ブッシュ	BUSHING	1
36	204115	座金	WASHER	1
37	5231	六角ネジ / C 5 × 1 6 . 5	SCREW	1
38	XXXXXX	差動送り歯	DIFFERENTIAL FEED DOG	1
39	211859	送り歯 (左)	FEED DOG (LEFT)	1
40	1175-2	平ネジ / C 4 × 8	SCREW	1
41	210156	角駒	BLOCK	1
42	206128	ニードルベアリング	NEEDLE BEARING	1
43	206129	止メ輪	RING	1
44	208235	座金	WASHER	1
45	210157	案内 (右) / 送り台	GUIDE (RIGHT)/FEED BAR	1
46	5205	平ネジ / C 5 × 8	SCREW	2
47	210158	案内 (左) / 送り台	GUIDE (LEFT)/FEED BAR	1
48	2902	平ネジ / C 5 × 1 0	SCREW	2
49	208168	ガスケット	GASKET	1
50	210160	案内 / 油切り	GUIDE/FEED BAR OIL SEAL	1
51	5346	平ネジ / C 3 × 4 . 2	SCREW	4
52	210159	油切り / 送り台	OIL SEAL	2

注: 「XXXXXXX」はゲージパーツです。

44頁を参照してください。

PLEASE NOTE: 「XXXXXXX」 is one of the gauge parts.

So please refer to page 44 and confirm the correct parts.

WWW

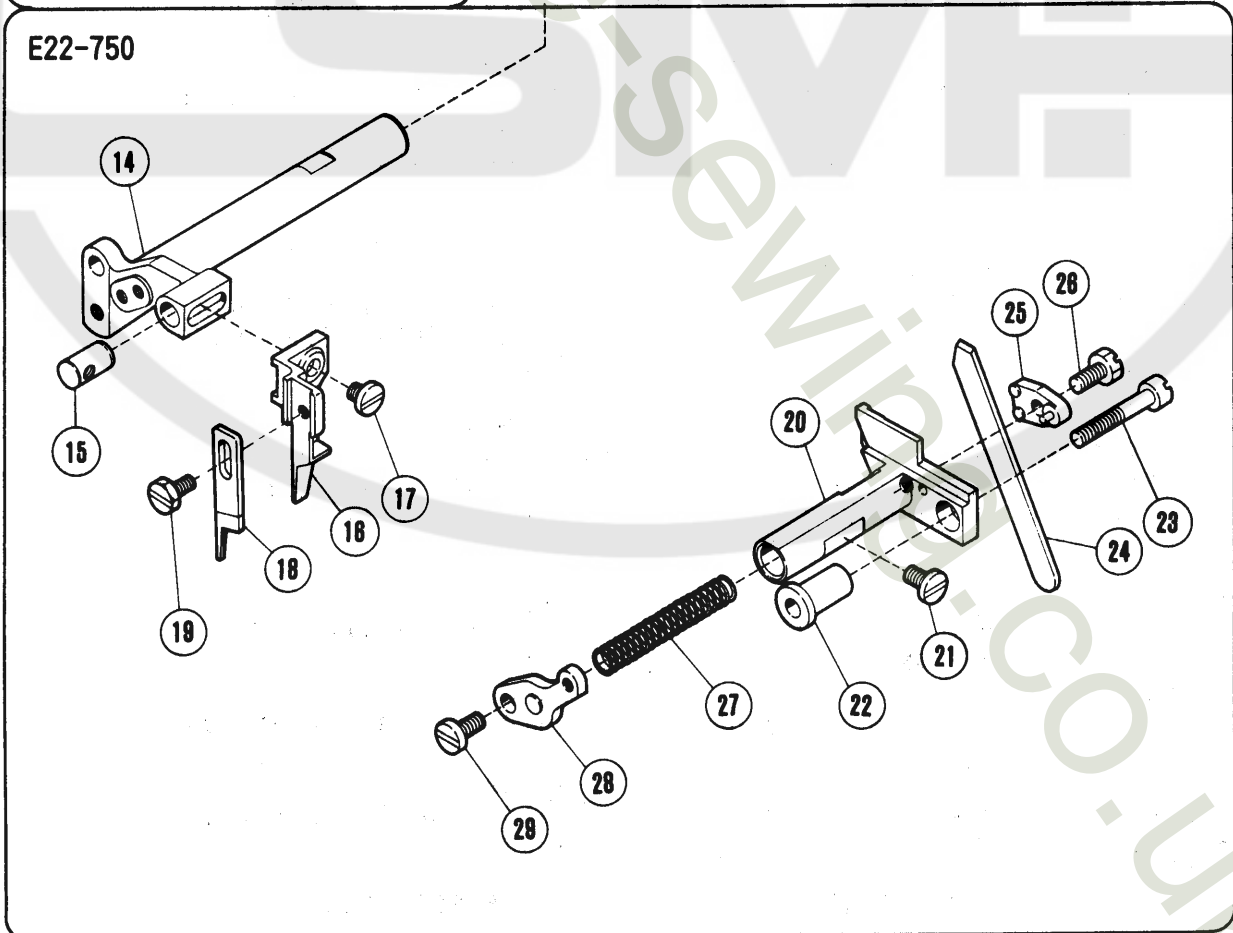
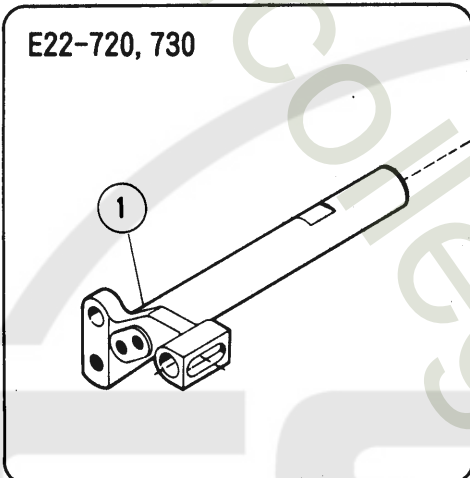
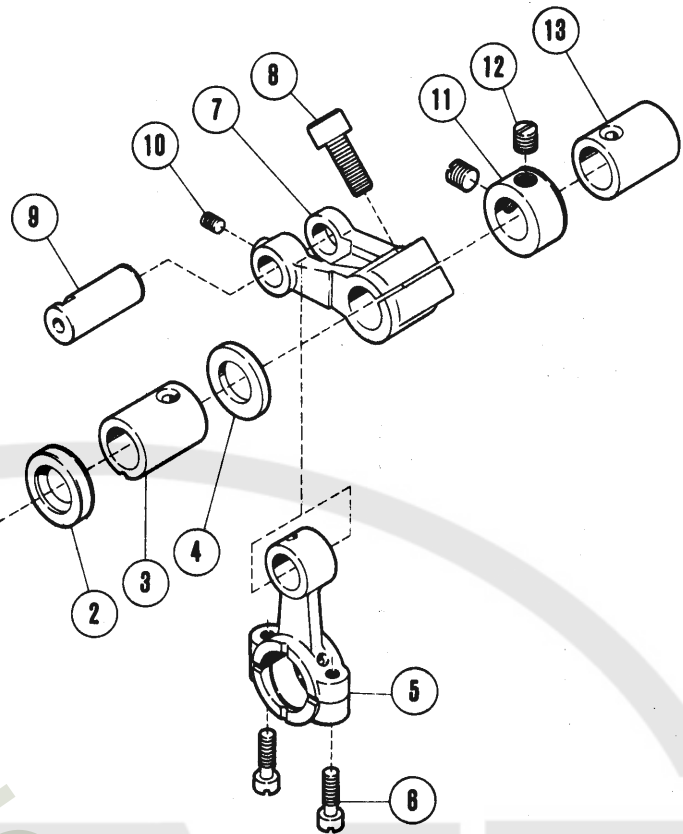

上下メス機構

KNIFE DRIVE MECHANISM

REF. PART NO. NO. 部品番号	名称	NAME	QT.
1 210269	上メス台	UPPER KNIFE LEVER	1
2 210069	オイルシール	OIL SEAL	1
3 210068	ブッシュ	BUSHING	1
4 206180	座金	WASHER	1
5 210173	ロッド/上メス	CONNECTION/UPPER KNIFE DRIVE	1
6 5376	平ネジ/C 4 × 1 2 . 5	SCREW	2
7 210314	クランク/上メス	CRANK/UPPER KNIFE DRIVE	1
8 5457	平ネジ/C 9 × 1 5	SCREW	1
9 210175	平行ピン	PIN	1
10 5461	止ネジ/C 5 × 5	SCREW	1
11 201635	カラー	COLLAR	1
12 5060	止ネジ/C 8 × 4 . 5	SCREW	2
13 210067	ブッシュ	BUSHING	1
14 212640	上メス台	UPPER KNIFE LEVER	1
15 208579	平行ピン	PIN	1
16 210315C	上メス抱キ	UPPER KNIFE CLAMP	1
17 5118	平ネジ/C 5 × 1 2	SCREW	1
18 202527A	上メス(狭巾)	UPPER KNIFE (NARROW)	1
19 5088	六角ネジ/C 4 × 7 . 5	SCREW	1
20 210316A	下メス台	LOWER KNIFE HOLDER	1
21 4009-1	平ネジ/C 5 × 7 . 5	SCREW	1
22 210180	案内/下メス台	GUIDE/LOWER KNIFE HOLDER	1
23 5094	平ネジ/C 5 × 2 6	SCREW	1
24 202295A	下メス/厚メス	LOWER KNIFE/THICK	1
25 210184	下メス押エ	CLAMP/LOWER KNIFE	1
26 2193	六角ネジ/C 5 × 8 . 5	SCREW	1
27 202340	圧縮バネ	SPRING	1
28 210183	下メスバネ受ケ	SPRING RETAINER	1
29 5117	平ネジ/C 5 × 8 . 5	SCREW	1

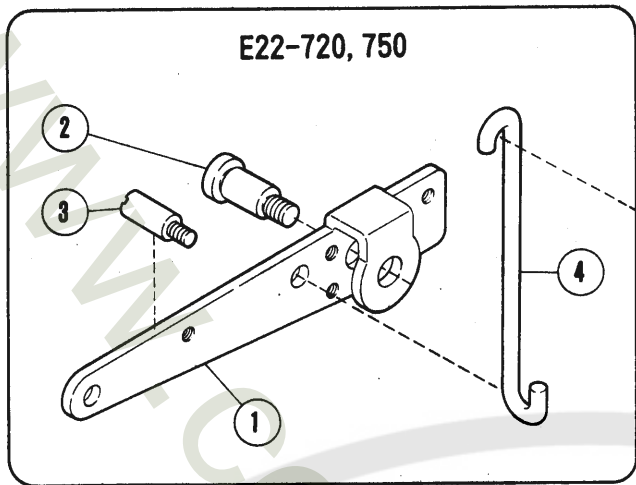

E22-730	8
E22-720, 750	7

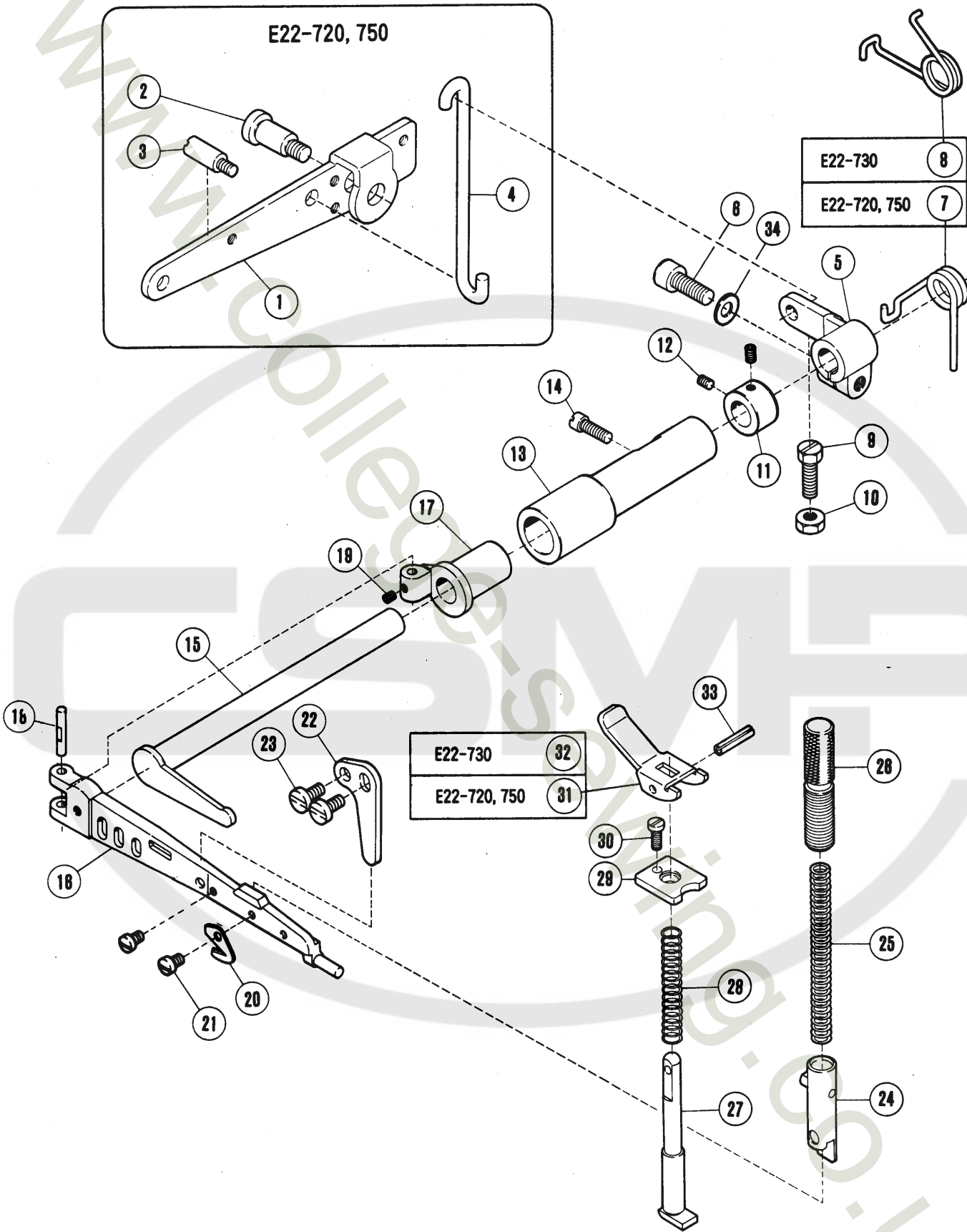

E22-730	32
E22-720, 750	31

押エ機構(1)

PRESSER FOOT MECHANISM (1)

REF. NO.	PART NO.	名称	NAME	QT.
1	211636	レバー / 足揚ゲ	LEVER/FOOT LIFT	1
2	2285	段付ネジ / C 9	SCREW	1
3	5481	ピン付ネジ / C 5	SCREW	1
4	210335	リンク / 足揚ゲレバー	LINK/FOOT LIFT LEVER	1
5	210329	レバー / 押エ揚ゲ	LEVER/FOOT LIFT	1
6	5457	平ネジ / C 9 × 1 5	SCREW	1
7	212988	ネジリバネ	SPRING	1
8	211860	ネジリバネ	SPRING	1
9	5276	六角ネジ / C 7 × 1 6	SCREW	1
10	5426	六角ナット / C 7	NUT	1
11	210728	カラー	COLLAR	1
12	5292	止ネジ / C 3 × 2 . 7	SCREW	2
13	210727	ブッシュ	BUSHING	1
14	2133-1	平ネジ / C 5 × 1 2 . 5	SCREW	1
15	210326	軸 / 押エ台	SHAFT/FOOT LIFT	1
16	210321	押エ台	PRESSER ARM	1
17	210322	ヒンジ / 押エ台	HINGE/PRESSER ARM	1
18	210323	平行ピン	PIN	1
19	5292	止ネジ / C 3 × 2 . 7	SCREW	1
20	202451	チェーンカッター	CHAIN CUTTER	1
21	1229	平ネジ / C 3 × 4 . 5	SCREW	2
22	210517	ストッパー / 押エ台	STOPPER/PRESSER ARM	1
23	5117	平ネジ / C 5 × 8 . 5	SCREW	2
24	208537	押エ棒 (組)	PRESSER BAR COMPLETE	1
25	210337	圧縮バネ	SPRING	1
26	208774	調節ネジ	THUMB SCREW	1
27	202645	手揚軸	PLUNGER	1
28	201395	圧縮バネ	SPRING	1
29	208599	案内板	BUSHING	1
30	5029	平ネジ / C 3 × 7 . 5	SCREW	1
31	211657	手揚ゲ	LEVER/HAND LIFT	1
32	211253	レバー / 手揚ゲ	LEVER/HAND LIFT	1
33	202647A	スプリングピン	PIN	1
34	207924	座金	WASHER	1

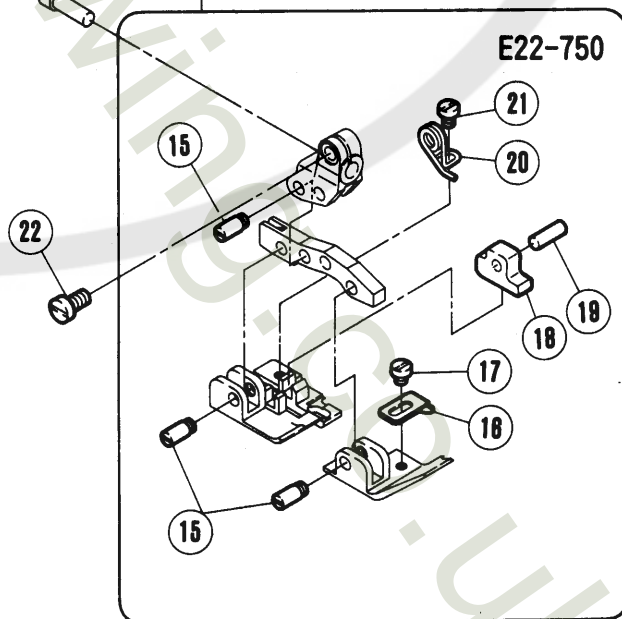
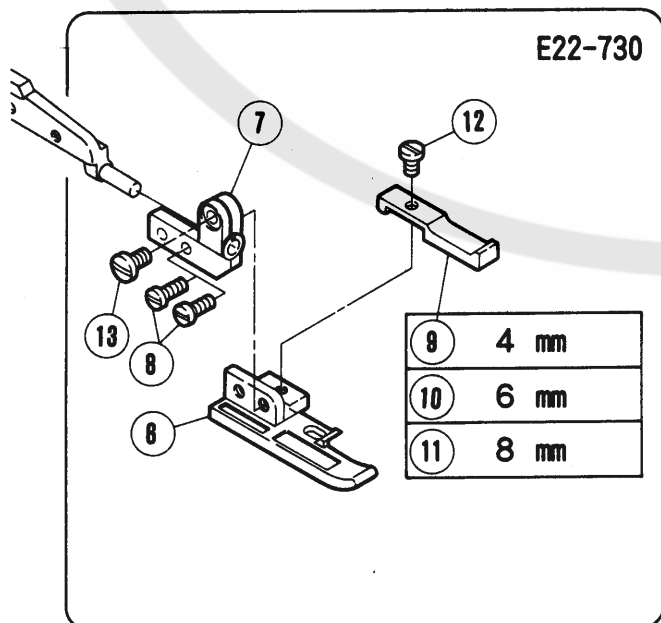
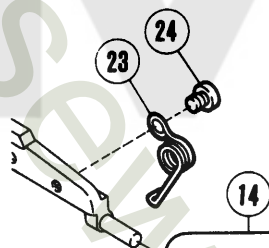
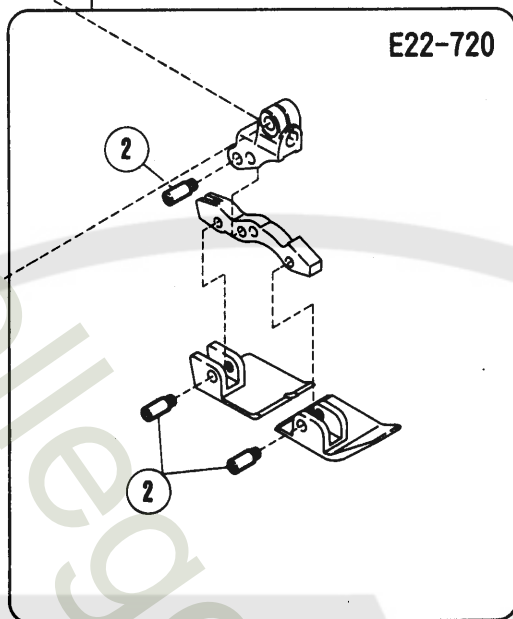
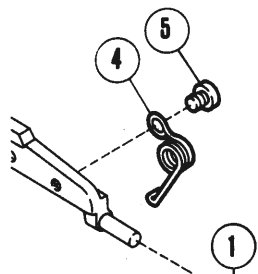

REF. PART NO. NO. 部品番号	名称	NAME	QT.
1 212863	押エ (組)	PRESSER FOOT COMPLETE	1
2 208958-B	ピン付ネジ / C 3	SCREW	3
3 5328	平ネジ / C 4 × 6 . 3	SCREW	1
4 208960	ネジリバネ	SPRING	1
5 2921	平ネジ / C 3 × 4	SCREW	1
6 208767	押エ (長)	PRESSER FOOT (LONG)	1
7 208636	押エ取付台	BRACKET/PRESSER FOOT	1
8 1196	平ネジ / C 3 × 6 . 5	SCREW	2
9 208768	小押エ (4)	SHOE/PRESSER FOOT (4)	1
10 208769	小押エ (6)	SHOE/PRESSER FOOT (6)	1
11 208770	小押エ (8)	SHOE/PRESSER FOOT (8)	1
12 1229	平ネジ / C 3 × 4 . 5	SCREW	1
13 5328	平ネジ / C 4 × 6 . 3	SCREW	1
14 209238	押エ (組)	PRESSER FOOT COMPLETE	1
15 208958-B	ピン付ネジ / C 3	SCREW	3
16 208575	補助押エ	FABRIC GUARD	1
17 5030	平ネジ / C 1 × 2 . 3	SCREW	1
18 208899	空環押エ	CLAMP/THREAD CHAIN	1
19 208900	平行ピン	PIN	1
20 208374	ネジリバネ	SPRING	1
21 1231	平ネジ / C 1 × 3 . 4	SCREW	1
22 5328	平ネジ / C 4 × 6 . 3	SCREW	1
23 208960	ネジリバネ	SPRING	1
24 2921	平ネジ / C 3 × 4	SCREW	1

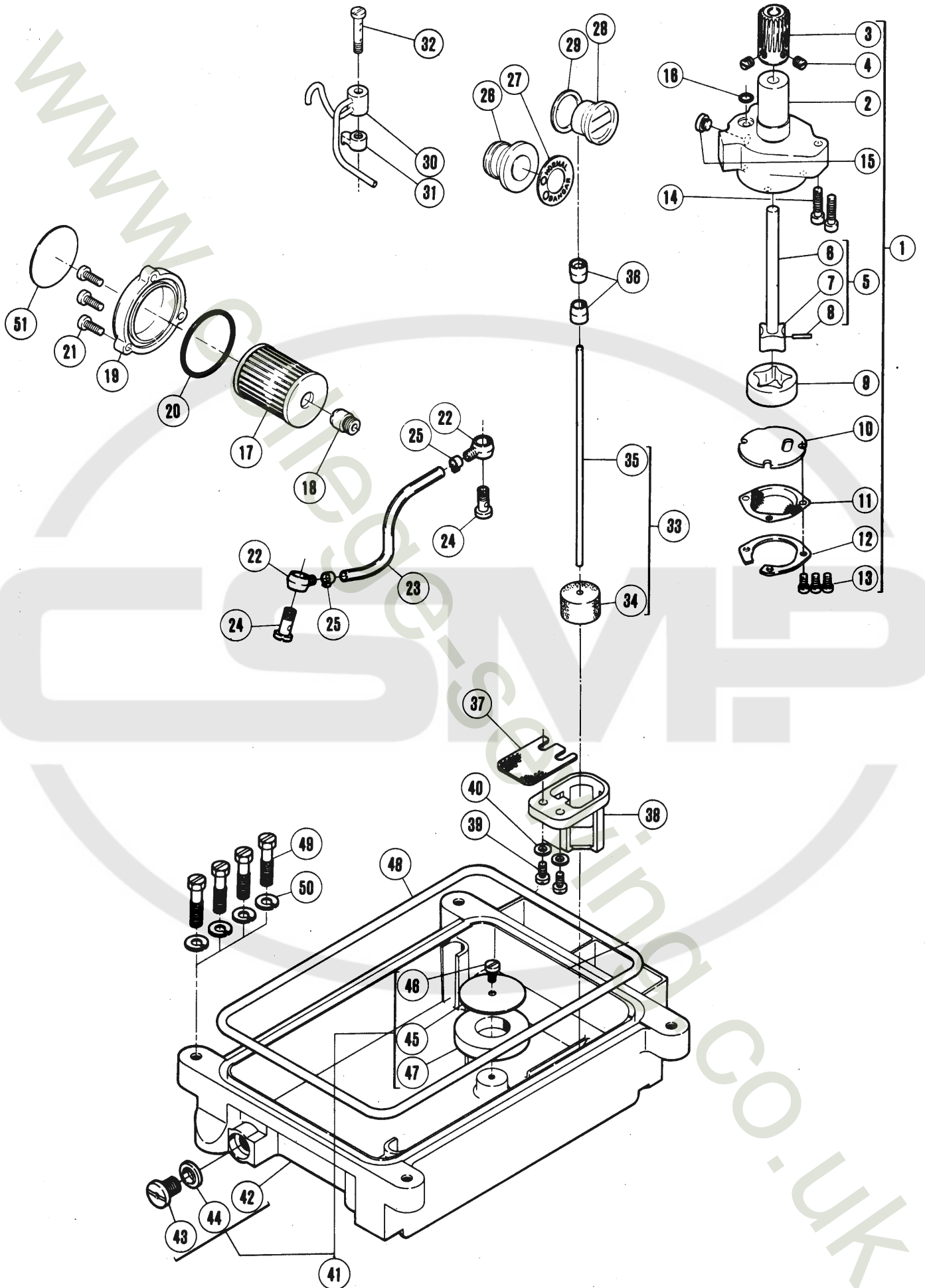

給油機構

LUBRICATION MECHANISM

REF. NO.	PART NO. 部品番号	名称	NAME	QT.
1	212972-91	ポンプ (組)	TROCHOID PUMP ASSEMBLY	1
2	212976	ポンプ本体	TROCHOID PUMP	1
3	211531	ウォームホイール	WORM WHEEL	1
4	5060	止ネジ / C 8 × 4 . 5	SCREW	2
5	212978-91	ローター (内) 軸	ROTOR (INSIDE) SHAFT	1
6	212979	軸	SHAFT	1
7	212980	ローター (内)	ROTOR (INSIDE)	1
8	206468	平行ピン	PIN	1
9	212981	ローター (外)	ROTOR (OUTSIDE)	1
10	212982	側板	PLATE	1
11	213578	フィルター	FILTER	1
12	213579	当金	GUIDE	1
13	1175-2	平ネジ / C 4 × 8	SCREW	3
14	5095	平ネジ / C 5 × 1 9	SCREW	2
15	5145	平ネジ / C 1 0 × 3	SCREW	1
16	204185	リング	O RING	1
17	206233	エレメント	OIL FILTER	1
18	210200	ブラケット / フィルター	BRACKET/OIL FILTER	1
19	210201-FD	フィルター蓋	OIL FILTER CAP	1
20	206431	リング	O RING	1
21	5118	平ネジ / C 5 × 1 2	SCREW	3
22	200136	継手	JOINT	2
23	205113A	給油パイプ	OIL TUBE	1
24	200152	継手ネジ	JOINT SCREW	2
25	202199	クランプ	CLAMP	2
26	210198	給油標示 (組)	OIL MONITOR COMPLETE	1
27	210199	銘板 / 給油標示	NAME PLATE/OIL MONITOR	1
28	210190	オイルゲージ	OIL SIGHT GAUGE	1
29	211369	座金	WASHER	1
30	212188	噴油管	OIL DISTRIBUTOR	1
31	210202	給油ブロック	LUBRICATION BLOCK	1
32	212998	継手ネジ	JOINT SCREW	1
33	210193	オイル指示 (組)	INDICATOR COMPLETE	1
34	179257-05	フロート	FLOAT	1
35	210192	オイル指示	INDICATOR	1
36	210194	案内 / オイル指示	INDICATOR GUIDE	2
37	213633	フィルター	FILTER	1
38	210510	オイル指示受	INDICATOR SUPPORT	1
39	5118	平ネジ / C 5 × 1 2	SCREW	2
40	201185	座金	WASHER	2
41	212634	オイルパン (組)	OIL RESERVOIR COMPLETE	1
42	210211	オイルパン	OIL RESERVOIR	1
43	5138B	平ネジ / H 1 1 × 1 2	SCREW	1
44	202287A	座金	WASHER	1
45	210521	マグネット台座	MAGNET BRACKET	1
46	5117	平ネジ / C 5 × 8 . 5	SCREW	1
47	210520	マグネット	MAGNET	1
48	210212	リング	O RING	1
49	5133	六角ボルト	BOLT	4
50	202045	バネ座金	SPRING WASHER	4
51	9A3002	フィルターシール	FILTER SEAL	1

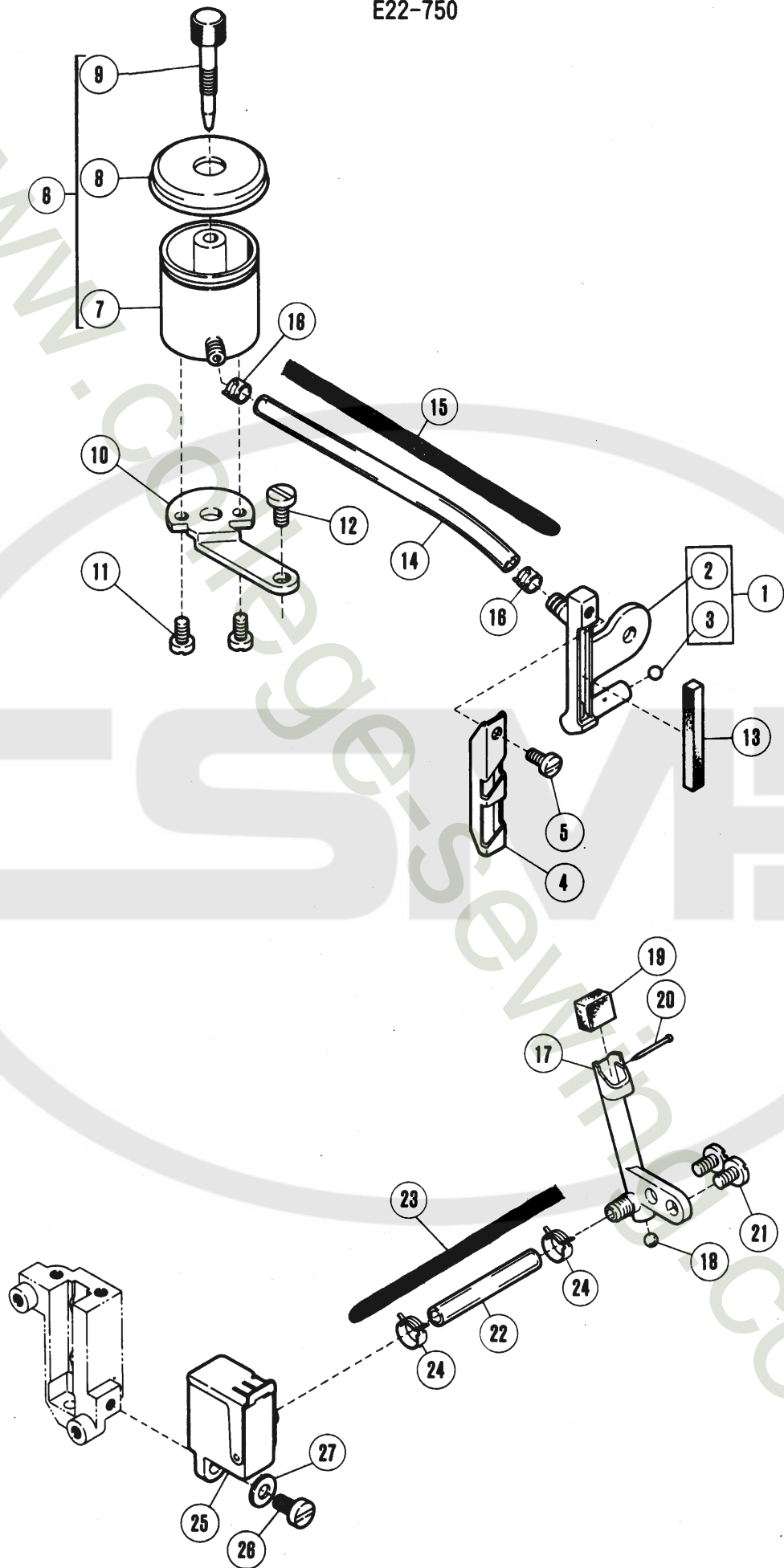

H.R.装置

H. R. DEVICE

REF. NO.	PART NO.	名称	NAME	QT.
1	212635-ME	針冷却器(組)	NEEDLE COOLER ASSEMBLY	1
2	211315	針冷却器	NEEDLE THREAD LUBRICATOR	1
3	240097	栓	PLUG	1
4	211316	糸案内	THREAD GUIDE	1
5	1202	平ネジ / C 4 × 7	SCREW	1
6	205897-91	シリコンタンク(上)組	SILICONE OIL RESERVOIR (UPPER)	1
7	202476-1	シリコンタンク(上)	SILICONE OIL RESERVOIR (UPPER)	1
8	202476-4	蓋	CAP	1
9	202476-3	油量調節棒	SILICONE OIL REGULATOR	1
10	211317	ブラケット	BRACKET	1
11	1202	平ネジ / C 4 × 7	SCREW	2
12	5117	平ネジ / C 5 × 8 . 5	SCREW	1
13	211318	フェルト	OIL FELT	1
14	211319	チューブ	OIL TUBE	1
15	202176	給油紐	OIL WICK	1
16	200155	クランプ	TUBE CLAMP	2
17	212642	針冷却器	NEEDLE COOLER	1
18	210214	栓	PLUG	1
19	204466	給油フェルト	OIL WICK	1
20	210766	止ピン	PIN	1
21	5091	平ネジ / C 5 × 7 . 5	SCREW	2
22	211639	チューブ	OIL TUBE	1
23	202176	給油紐	OIL WICK	1
24	200155	クランプ	TUBE CLAMP	2
25	210539	シリコンタンク(下)組	SILICONE OIL RESERVOIR (LOWER)	1
26	5345	平ネジ / C 5 × 1 1	SCREW	1
27	201185	座金	WASHER	1

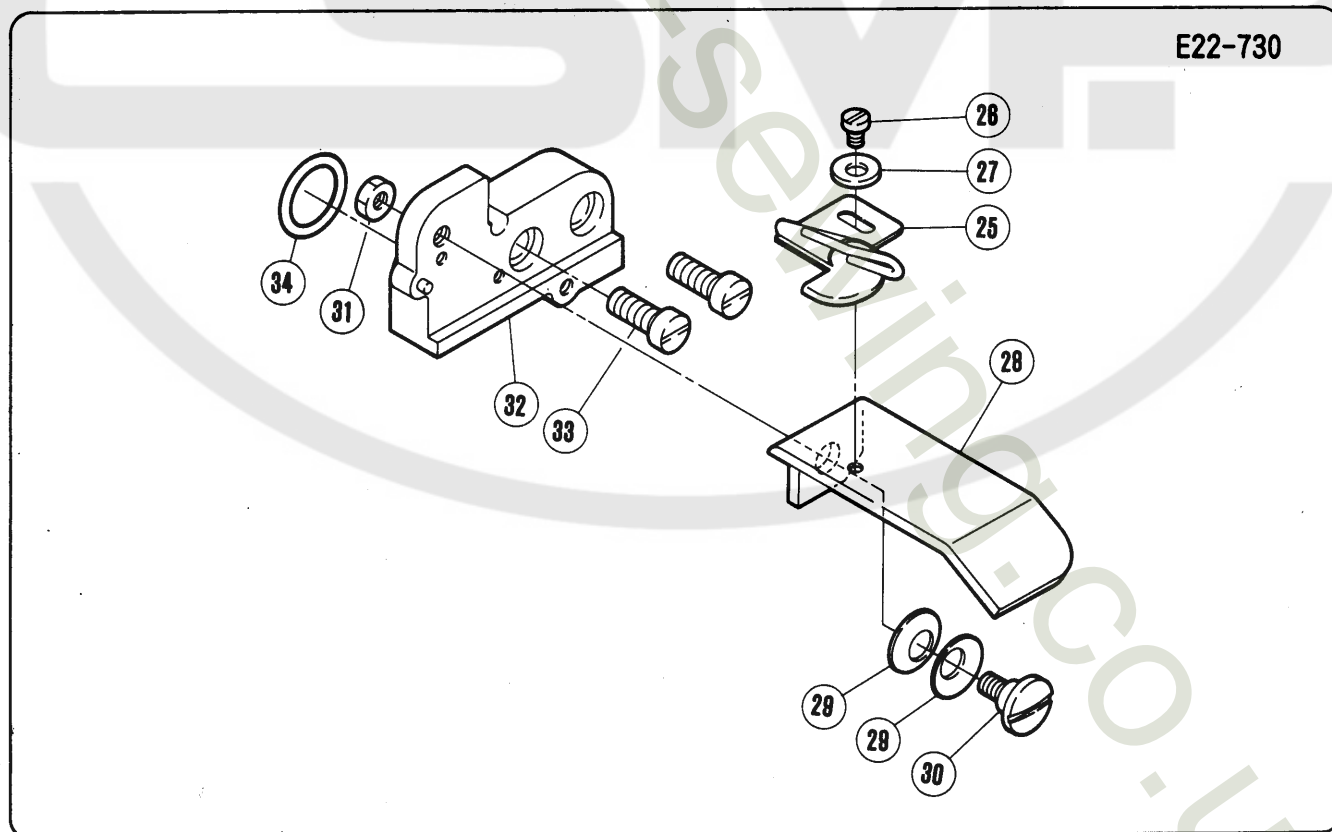
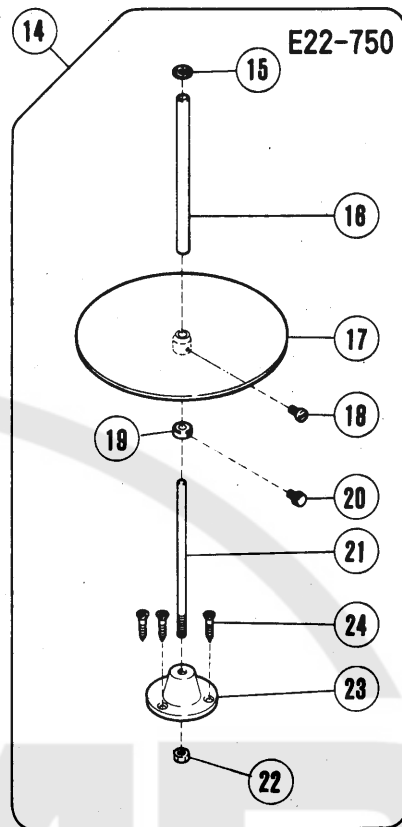
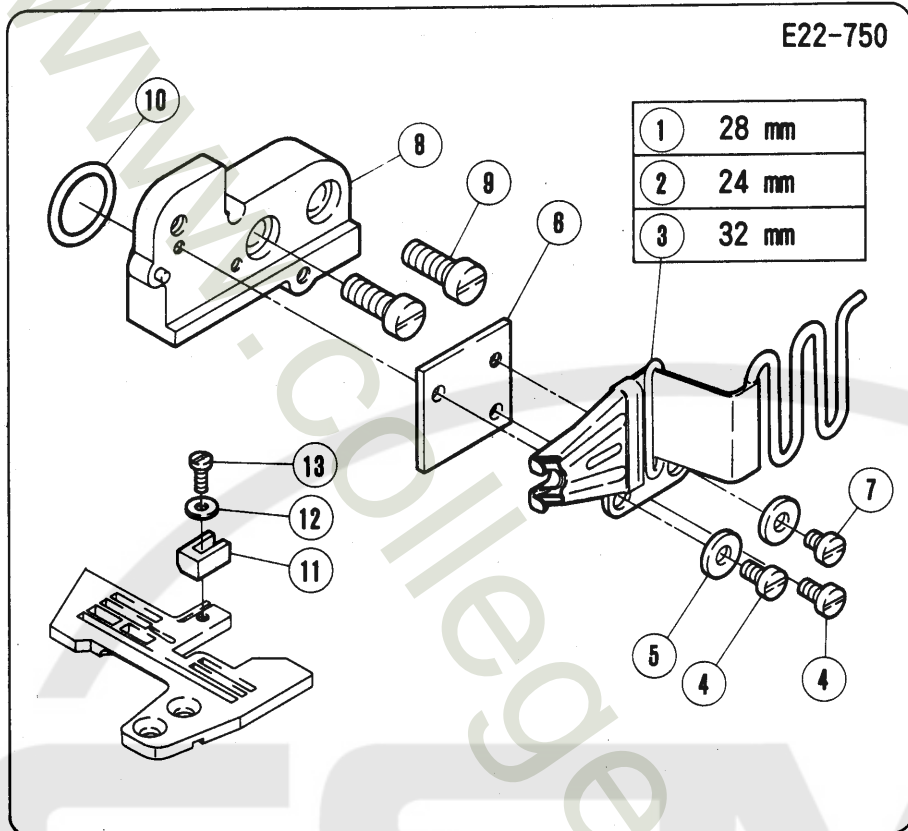

REF. NO.	PART NO. 部品番号	名称	NAME	QT.
1	208389	バインダー (組) (28)	BINDER COMPLETE (28)	1
2	208390	バインダー (組) (24)	BINDER COMPLETE (24)	1
3	208757	バインダー (組) (32)	BINDER COMPLETE (32)	1
4	1189	平ネジ / C 4 × 7.5	SCREW	2
5	137142	座金	WASHER	2
6	212641	ブラケット	BRACKET	1
7	1216	平ネジ / C 4 × 5.5	SCREW	1
8	211862	ブラケット	BRACKET	1
9	5282	平ネジ / C 9 × 16	SCREW	2
10	206004	Oリング	O RING	1
11	208569	バインダー補助板	TAPE GUIDE	1
12	2918	平ネジ / C 3 × 8.5	SCREW	1
13	202875	座金	WASHER	1
14	403	テープガイド (組)	TAPE DISC ASSEMBLY	1
15	406	フェルト	FELT	1
16	405	取付棒	FIXING ROD	1
17	404	カノコ台	TAPE DISC	1
18	4012	平ネジ / M 4 × 12	SCREW	1
19	407	カラージ	COLLAR	1
20	408	調節ネジ	ADJUSTING SCREW	1
21	409	軸	SHAFT	1
22	4818	六角ナット / M 6	NUT	1
23	410-JA	ブラケット	BRACKET	1
24	4908	木ネジ (皿) / 4.5	SCREW	3
25	208638	バインダー (組)	BINDER COMPLETE	1
26	1216	平ネジ / C 4 × 5.5	SCREW	1
27	137142	座金	WASHER	1
28	211861	ブラケット / バインダー	BRACKET/BINDER	1
29	204888	皿バネ	SPRING	2
30	5380	段付ネジ / C 8	SCREW	1
31	5104	六角ナット / C 8	NUT	1
32	211862	ブラケット	BRACKET	1
33	5282	平ネジ / C 9 × 16	SCREW	2
34	206004	Oリング	O RING	1

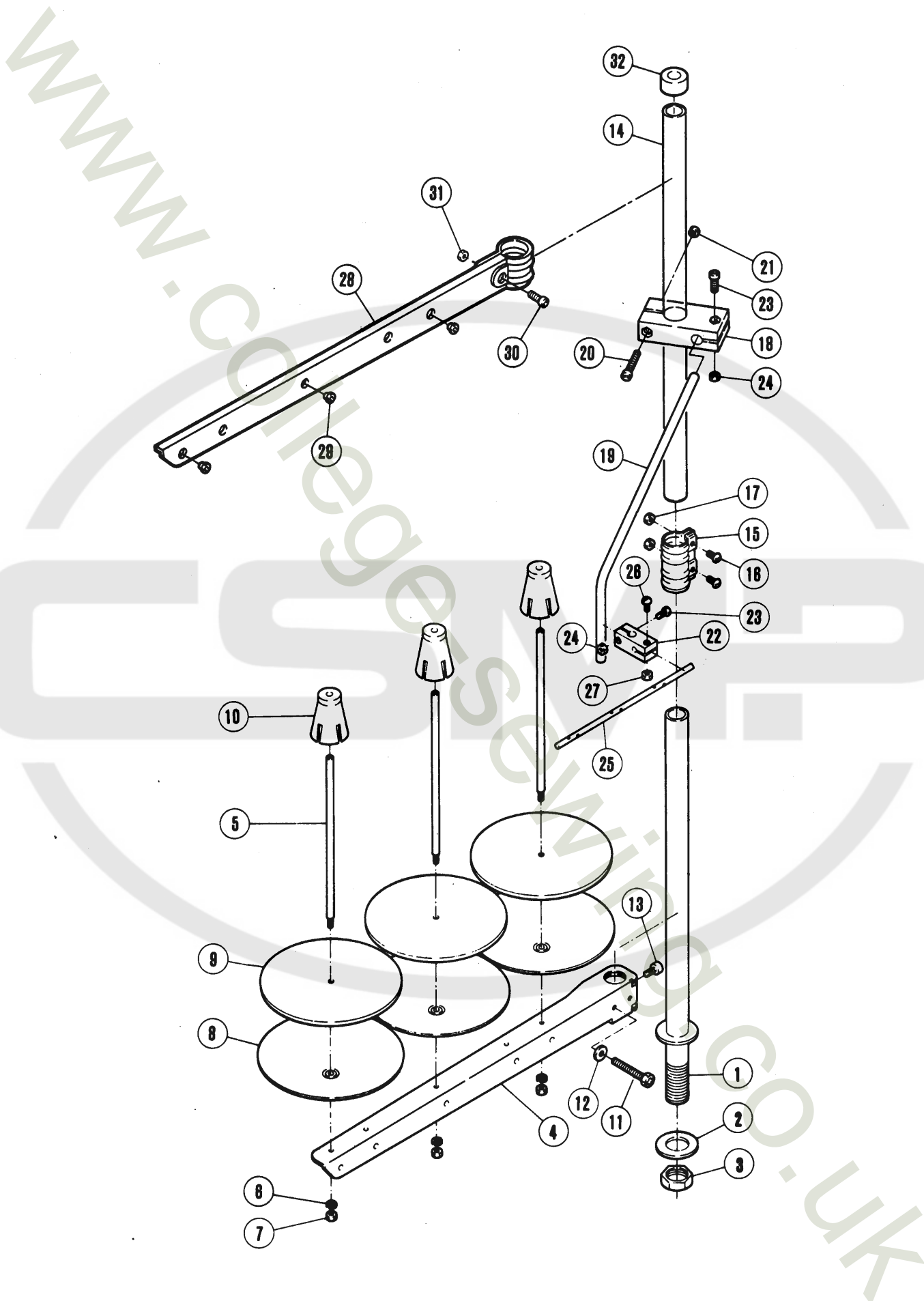

糸立台

THREAD STAND

REF. NO.	PART NO. 部品番号	名称	NAME	QT.
1	486C9C	糸立(組)(3本立)	THREAD STAND ASS. (3-SPOOLS)	1
2	503-CA	スタンド棒(下)	THREAD STAND ROD (LOWER)	1
3	509	座金	WASHER	1
4	5476	六角ナット	NUT	1
5	505-CA	ブラケット(3本立)	BRACKET	1
6	380A	糸立棒	SPOOL PIN	3
7	201252	バネ座金	SPRING WASHER	3
8	4803	六角ナット/M4	NUT	3
9	381-CA	受皿	SPOOL TRAY	3
10	507	ウレタン	CUSHION	3
11	382-CA	ユレ止メ	SPOOL RETAINING FIN	3
12	7102	六角ネジ/M6×3.2	SCREW	1
13	512	座金	WASHER	1
14	4022	平ネジ/M6×1.0	SCREW	1
15	502-CA	スタンド棒(上)	THREAD STAND ROD (UPPER)	1
16	504-CA	ジョイント	JOINT	1
17	4021	平ネジ/M5×1.6	SCREW	2
18	4805	六角ナット/M5	NUT	2
19	383-CA	ブラケット	BRACKET	1
20	384	糸道棒腕	THREAD GUIDE BAR ROD	1
21	4014	平ネジ/M4×2.5	SCREW	1
22	4803	六角ナット/M4	NUT	1
23	233-CA	ホルダー	HOLDER	1
24	4012	平ネジ/M4×1.2	SCREW	2
25	4803	六角ナット/M4	NUT	2
26	293C	糸道棒(3本立)	THREAD GUIDE BAR (3-SPOOLS)	1
27	4012	平ネジ/M4×1.2	SCREW	1
28	4803	六角ナット/M4	NUT	1
29	527-CA	ブラケット(3本立)	BRACKET	1
30	506	糸道	THREAD GUIDE	3
31	4117	止ネジ/M5×1.2	SCREW	1
32	4805	六角ナット/M5	NUT	1
33	386	キャップ	ROD CAP	1

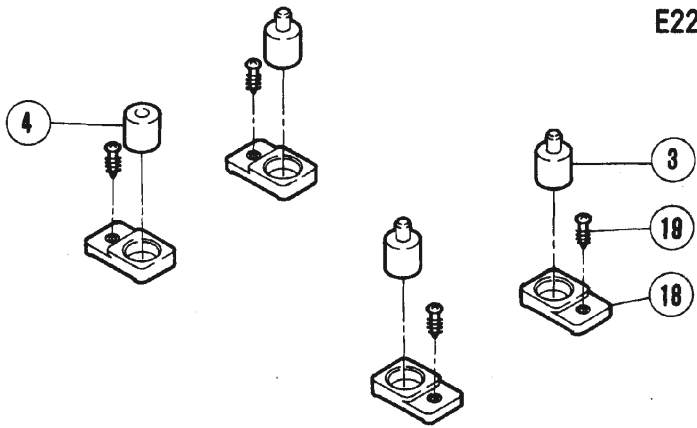
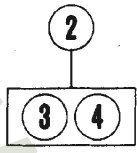

E22-750

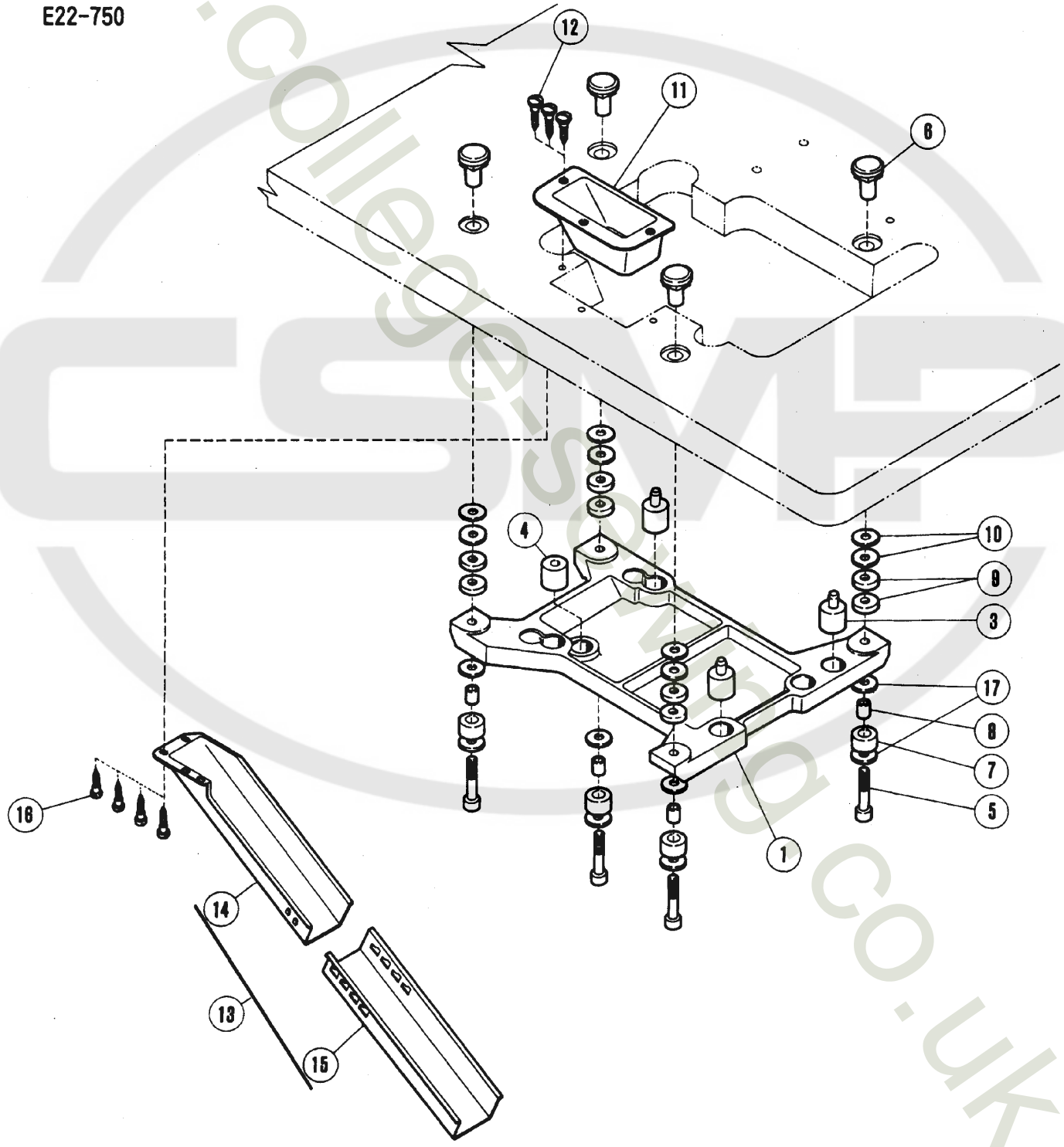

半沈床式据付付属品

PARTS FOR SEMI-SUBMERGED INSTALLATION

REF. NO.	PART NO. 部品番号	名称	NAME	QT.
1	205466	マシン据付板	MACHINE REST BOARD	1
2	9029	防振ゴム (セット)	CUSHION RUBBER (SET)	1
3	205473	防振ゴム	CUSHION RUBBER	3
4	210523	防振ゴム	CUSHION RUBBER	1
5	4513	ボルト / M 8	BOLT	4
6	206336	半沈用ナット	NUT	4
7	205764	防振ゴム	CUSHION RUBBER	4
8	205765	ライナー	LINER	4
9	205467	スペーサー	SPACER	8
10	206337	座金	WASHER	8
11	205470-JA	切屑受	WASTE CHUTE TOP	1
12	4904	木ネジ (皿) / 3. 5	SCREW	3
13	9106	切屑受 (セット)	WASTE CHUTE SET	1
14	205468-JA	切屑受 (A)	WASTE CHUTE TOP (A)	1
15	205469-JA	切屑受 (B)	WASTE CHUTE TOP (B)	1
16	4905	木ネジ (平) / 4. 5	SCREW	4
17	206337	座金	WASHER	8
18	208756	取付台 / クッションゴム	BRACKET / CUSHION RUBBER	4
19	4905	木ネジ (平) / 4. 5	SCREW	4

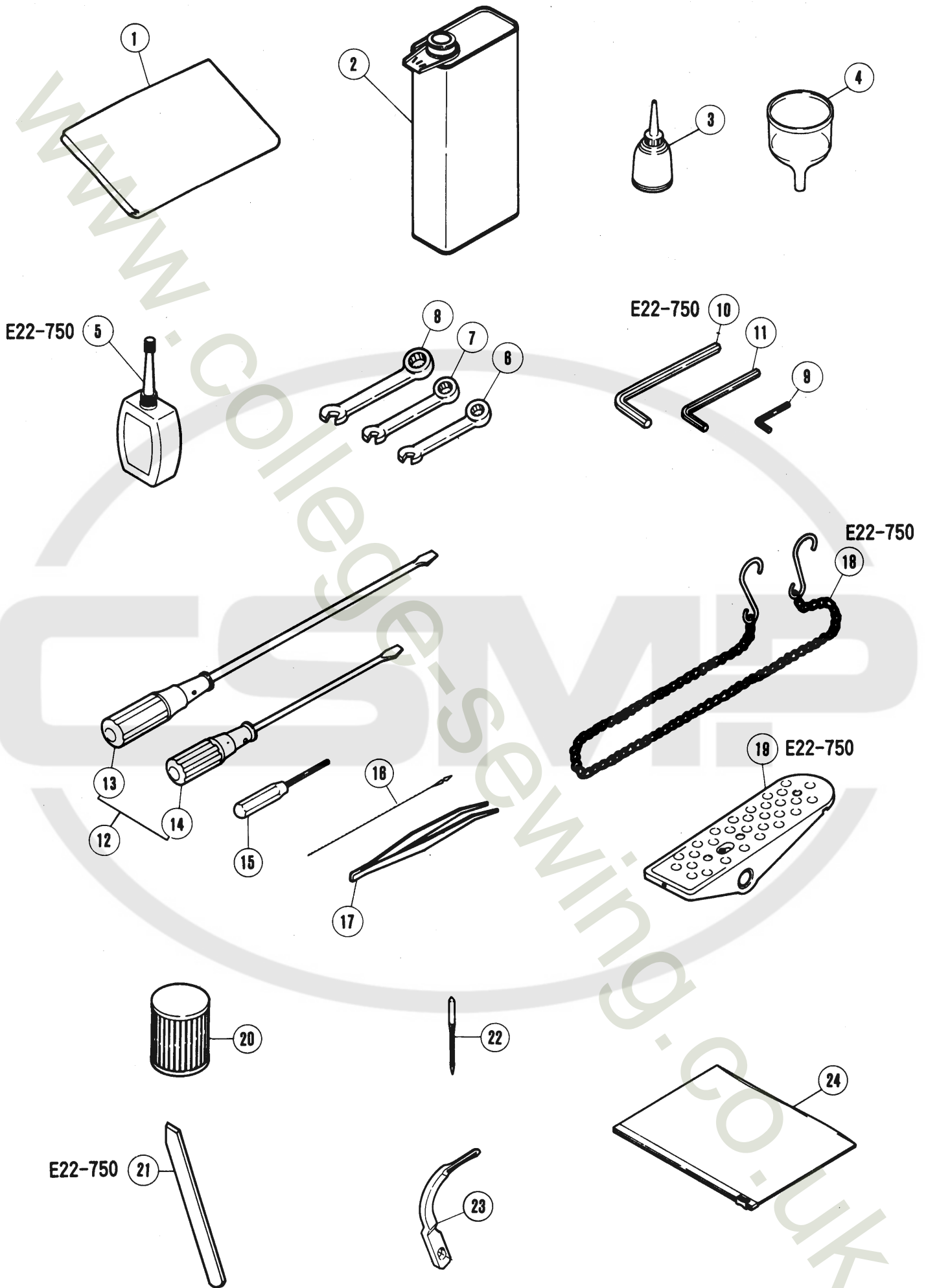

付属品

ACCESSORIES

REF. NO.	PART NO. 部品番号	名称	NAME	QT.
1	908	ナイロンカバー (中)	DUST COVER	
2	453	油缶 / 1000CC	OIL CONTAINER/1000CC	
3	485	油差シ	OILER	
4	484	ジョウゴ	OIL FUNNEL	
5	178	シリコンオイル / 50CC	CONTAINER - SILICONE	
6	391	スパナ / 5MM	WRENCH/5MM	
7	284	スパナ / 7MM	WRENCH/7MM	
8	285	スパナ / 8MM	WRENCH/8MM	
9	322	キーレンチ / 2.38MM	ALLEN KEY/2.38MM	
10	272	キーレンチ / 6MM	ALLEN KEY/6MM	
11	200	キーレンチ / 4.76MM	ALLEN KEY/4.76MM	
12	9105	ドライバー組 (大, 中)	SCREWDRIVER (LARGE, MEDIUM)	
13	127	ドライバー (大)	SCREWDRIVER (LARGE)	
14	128	ドライバー (中)	SCREWDRIVER (MEDIUM)	
15	179	キーレンチドライバー	ALLEN KEY DRIVER	
16	153	糸通シ具	THREADING WIRE	
17	131	ピンセット	TWEEZERS	
18	392	鎖	CHAIN	
19	478	ペダル	PEDAL	
20	206233	エレメント	OIL FILTER	
21	202295A	下メス / 厚メス	LOWER KNIFE/THICK	
22	XXXXXX	針	NEEDLE	
23	210357	二重環ルーバー	DOUBLE CHAINSTITCH LOOPER	
24	482	アクセサリバッグ	ACCESSORY BAG	

注: 「XXXXXX」はゲージパーツです。

44頁を参照してください。

PLEASE NOTE: 「XXXXXX」 is one of the gauge parts.

So please refer to page 44 and confirm the correct parts.

E22-730/401-203

E22-720/401-293

E22-750/401-253

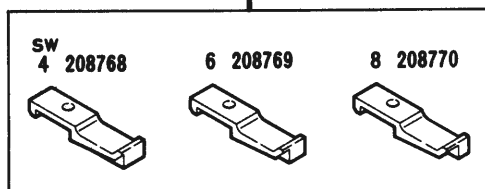
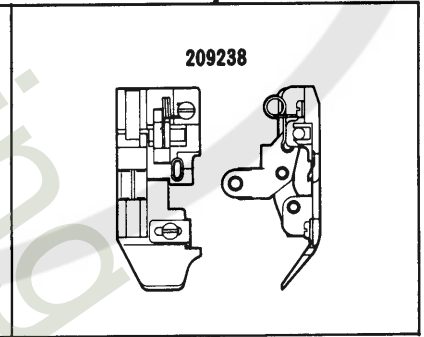
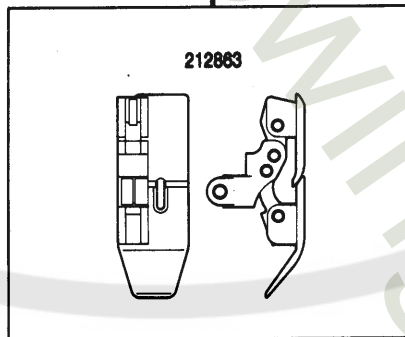
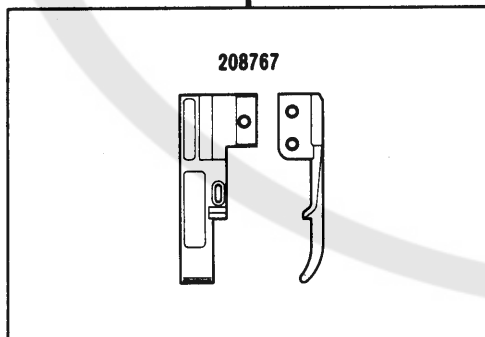
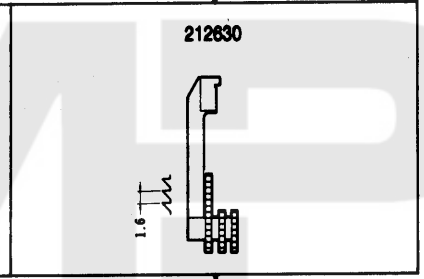
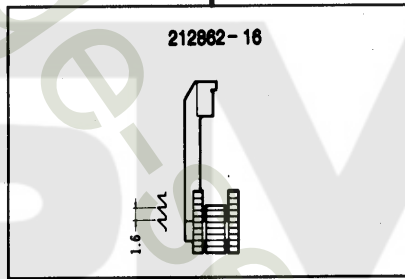
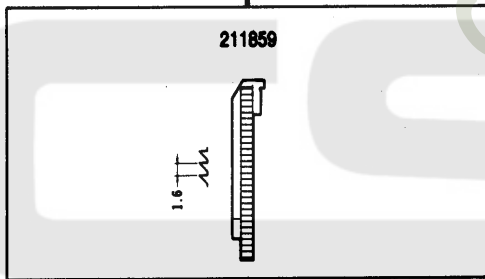
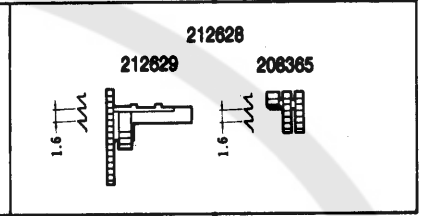
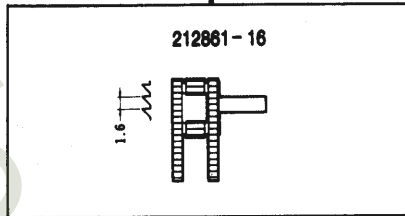
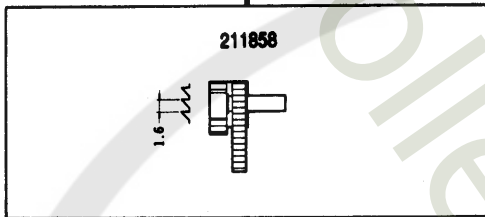
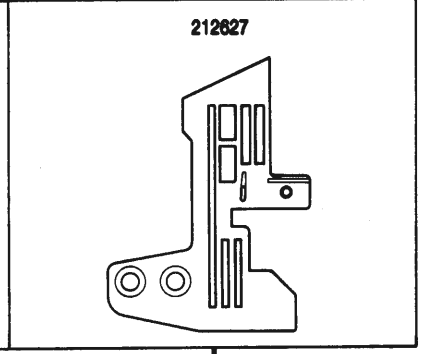
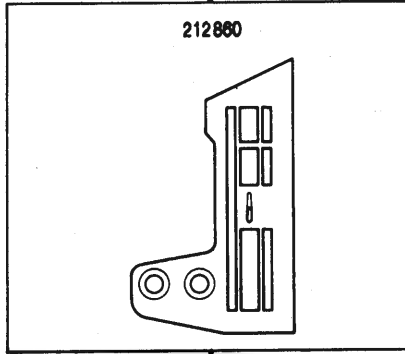
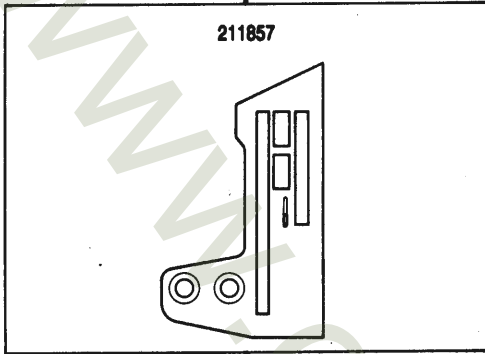

E22-730/401-203

E22-720/401-293

E22-750/401-253

E22-730/401-203

E22-720/401-293

E22-750/401-253

210357

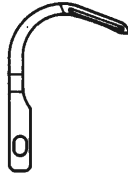

210278

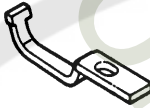

210279

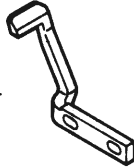

212638



212639



210273



210274



210274A



202527A



202295A



型式 MACHINE TYPE	ゲージ	針板	主送り歯(組)	(主送り歯本体)	(補助送り歯)	差動送り歯	押エ(組)	ルーパー
	GAUGE	NEEDLE PLATE	MAIN FEED DOG ASS.	MAIN FEED DOG	AUX. FEED DOG	DIFF. FEED DOG	PRESSER FOOT	LOOPER
E22-720/401-293	NG	212860		212861-16		212862-16	212863	210357
E22-750/401-253		212627	212628	212629	208365	212630	209238	210357

型式 MACHINE TYPE	ゲージ	針受(前)	針受(後)	針置	上メス	下メス	針
	GAUGE	NDL GUARD (FRONT)	NDL GUARD (REAR)	NEEDLE HOLDER	UPPER KNIFE	LOWER KNIFE	NEEDLE
E22-720/401-293	NG	210278	210279	210274			DC X 27 #16
E22-750/401-253		212638	212639	210274A	202527A	208393	DC X 27 #14

型式 MACHINE TYPE	ゲージ	針板	送り歯(右)	送り歯(左)	押エ	小押エ	ルーパー	針受(前)	針受(後)	針置	上メス	下メス	針
	GAUGE	NEEDLE PLATE	FEED DOG (RIGHT)	FEED DOG (LEFT)	PRESSER FOOT	SHOE	LOOPER	NDL GUARD (FRONT)	NDL GUARD (REAR)	NEEDLE HOLDER	UPPER KNIFE	LOWER KNIFE	NEEDLE
E22-730	NG	211857	211858	211859	208767	208768	210357	210278	210279	210273			DC X 27 #16
/401-203						208769							
						208770							

INDEX

PART NO.	PAGE	NO. REF.	PART NO.	PAGE	NO. REF.	PART NO.	PAGE	NO. REF.	PART NO.	PAGE	NO. REF.	PART NO.	PAGE	NO. REF.	PART NO.	PAGE	NO. REF.
DCX27 #14	44		2913-1	3	21	5205	23	46	137906	17	42	205473	39	3			
DCX27 #16	44		2918	35	12	5231	23	37	179257-05	31	34	205722	7	19			
	127	41 13	2921	29	5	5259	17	25	192130	5	14	205764	39	7			
	128	41 14	2921	29	24	5276	27	9	198192	3	13	205765	39	8			
	131	41 17	2922	15	32	5282	35	9	200136	31	22	205897-91	33	6			
	153	41 16	3044	5	16	5282	35	33	200152	31	24	206004	35	10			
	178	41 5	3044	17	11	5292	7	30	200155	33	16	206004	35	34			
	179	41 15	3091	5	20	5292	11	19	200155	33	24	206115	17	4			
	200	41 11	4009-1	3	16	5292	11	25	200555	7	29	206128	23	42			
233-CA	37	22	4009-1	3	40	5292	13	20	200697	7	11	206129	23	43			
	272	41 10	4009-1	5	4	5292	13	22	201002	3	10	206180	25	4			
	284	41 7	4009-1	5	34	5292	17	30	201002	3	23	206233	31	17			
	285	41 8	4009-1	7	8	5292	19	19	201037	13	4	206233	41	20			
	293C	37 25	4009-1	7	23	5292	21	38	201056	11	9	206336	39	6			
	322	41 9	4009-1	7	36	5292	27	12	201185	5	5	206337	39	10			
	380A	37 5	4009-1	17	2	5292	27	19	201185	21	29	206337	39	17			
	381-CA	37 8	4009-1	17	44	5316	21	6	201185	31	40	206431	31	20			
	382-CA	37 10	4009-1	23	12	5317	23	19	201185	33	27	206468	31	8			
	383-CA	37 18	4009-1	25	21	5328	7	42	201252	37	6	208009	7	28			
	384	37 19	4012	35	18	5328	9	8	201395	27	28	208028	15	40			
	386	37 32	4012	37	23	5328	13	33	201635	11	37	208029	15	41			
	391	41 6	4012	37	26	5328	15	21	201635	23	3	208168	23	49			
	392	41 18	4014	37	20	5328	29	3	201635	25	11	208173	3	25			
	403	35 14	4021	37	16	5328	29	13	202045	31	50	208173	3	36			
	404	35 17	4022	37	13	5328	29	22	202047	3	41	208173	3	39			
	405	35 16	4117	37	30	5332A	3	22	202174	3	14	208194	15	18			
	406	35 15	4513	39	5	5345	33	26	202174	11	26	208195	15	19			
	407	35 19	4802	15	43	5346	21	4	202175	11	12	208196	15	36			
	408	35 20	4803	37	7	5346	23	51	202175	11	20	208235	23	44			
	409	35 21	4803	37	21	5357	3	6	202176	11	24	208245	5	26			
	410-JA	35 23	4803	37	24	5357	13	26	202176	15	20	208365	44				
	453	41 2	4803	37	27	5376	11	34	202176	33	15	208374	29	20			
	478	41 19	4805	37	17	5376	15	2	202176	33	23	208389	35	1			
	482	41 24	4805	37	31	5376	25	6	202199	31	25	208390	35	2			
	484	41 4	4818	35	22	5380	35	30	202286	15	8	208393	44				
	485	41 3	4904	39	12	5426	27	10	202286	15	15	208411	19	8			
	486C9C	37	4905	39	16	5427	19	18	202287A	31	44	208415	19	9			
	502-CA	37 14	4905	39	19	5434	3	20	202295A	25	24	208447	13	2			
	503-CA	37 1	4908	35	24	5437	19	12	202295A	41	21	208448	13	3			
	504-CA	37 15	5002	13	35	5453	17	39	202340	25	27	208449	13	7			
	505-CA	37 4	5012	5	12	5455	17	28	202433	17	27	208450	13	5			
	506	37 29	5022	11	15	5455	23	9	202451	27	20	208537	27	24			
	507	37 9	5029	9	6	5457	11	32	202476-1	33	7	208569	35	11			
	509	37 2	5029	27	30	5457	15	24	202476-3	33	9	208575	29	16			
	512	37 12	5030	29	17	5457	17	21	202476-4	33	8	208579	25	15			
	527-CA	37 28	5050	9	28	5457	19	23	202522	21	7	208582	15	12			
	908	41 1	5053	7	44	5457	21	3	202526	3	30	208599	27	29			
	1174	5 19	5059	11	30	5457	21	9	202527A	25	18	208627	9	3			
	1175-2	15 30	5060	7	6	5457	23	6	202527A	44		208636	29	7			
	1175-2	23 26	5060	7	16	5457	25	8	202577	11	23	208638	35	25			
	1175-2	23 40	5060	11	38	5457	27	6	202645	27	27	208747	7	20			
	1175-2	31 13	5060	23	4	5461	9	17	202647A	27	33	208756	39	18			
	1175-3	7 21	5060	25	12	5461	11	36	202849	13	9	208757	35	3			
	1175-3	13 13	5060	31	4	5461	15	38	202875	5	11	208767	29	6			
	1189	35 4	5077	17	37	5461	19	7	202875	35	13	208767	44				
	1196	29 8	5078	3	2	5461	19	21	204006	3	33	208768	29	9			
	1202	7 34	5082A	13	8	5461	25	10	204010	9	11	208768	44				
	1202	33 5	5084	15	22	5476	37	3	204052A	21	12	208769	29	10			
	1202	33 11	5084	15	42	5480	5	30	204084	19	14	208769	44				
	1216	7 18	5084	17	17	5481	27	3	204107	15	13	208770	29	11			
	1216	7 38	5084	21	14	5482	3	17	204114	23	35	208770	44				
	1216	17 35	5084	23	16	5483	5	15	204115	23	23	208774	27	26			
	1216	35 7	5088	25	19	5484-HC	13	24	204115	23	36	208899	29	18			
	1216	35 26	5091	21	35	5485	11	3	204128A	23	15	208900	29	19			
	1229	13 16	5091	33	21	5486	21	20	204129A	23	13	208958-B	29	2			
	1229	27 21	5094	25	23	5487	15	27	204146	11	35	208958-B	29	15			
	1229	29 12	5095	7	2	5488	5	24	204185	19	3	208960	29	4			
	1231	15 5	5095	31	14	5489	23	24	204185	31	16	208960	29	23			
	1231	29 21	5104	35	31	5492	13	37	204293	9	29	209059	21	1			
	1234	17 41	5117	3	28	5492	13	40	204293	15	25	209084	3	37			
	1435	5 27	5117	5	18	5492	13	42	204293	15	28	209238	29	14			
	1448	9 4	5117	7	12	5492	23	30	204319	9	9	209238	44				
	1457	11 10	5117	9	23	5494	17	32	204439A	23	18	210002	3	3			
	1459	5 28	5117	13	11	5501	13	28	204466	33	19	210003	3	24			
	1459	9 2	5117	17	6	5522	9	30	204754A	21	13	210003	3	26			
	1459	13 31	5117	21	18	5523	9	27	204756	21	15	210003	3	38			
	1732	21 26	5117	21	24	5526	17	7	204757	21	16	210005	3	27			
	2022-4	15 10	5117	25	29	5546	15	7	204873	9	10	210006	5	29			
	2133-1	11 8	5117	27	23	5589	7	14	204881	9	7	210007	5	31			

INDEX

PART NO.	PAGE	NO. REF.	PART NO.	PAGE	NO. REF.	PART NO.	PAGE	NO. REF.	PART NO.	PAGE	NO. REF.
210028-FB	7	9	210230	11	31	210766	33	20	240097	33	3
210034-HD	7	1	210232A	11	16	210883	5	2	240102	9	12
210035	7	3	210233	11	39	210898	13	29	240102	15	11
210036	7	5	210234	11	28	210922	13	27	240102	17	13
210037	7	7	210235	11	11	210923	13	30	240148	11	21
210042	7	27	210236	11	14	211247	5	35	240190	3	11
210043	7	31	210237A	11	18	211253	27	32	252005	17	15
210044	7	39	210238	11	13	211300	5	9	9A3002	31	51
210045	7	37	210239	11	1	211301	21	21			
210046	7	35	210240	11	2	211314	21	30			
210047	7	32	210241	11	4	211315	33	2			
210055	9	24	210242	11	7	211316	33	4			
210056	9	20	210243	11	17	211317	33	10			
210057	9	21	210244	11	22	211318	33	13			
210057	11	6	210260	13	15	211319	33	14			
210058	9	25	210264	13	10	211345AHD	9	26			
210062	9	5	210269	25	1	211369	31	29			
210067	25	13	210273	44		211386	17	5			
210068	25	3	210274	44		211387	17	10			
210069	11	27	210274A	44		211388	17	8			
210069	25	2	210277	13	38	211389	7	41			
210091	15	1	210277A	13	34	211392	13	25			
210092	15	6	210278	13	32	211398	13	12			
210093	15	3	210278	44		211526	9	18			
210100	23	11	210279	13	36	211527	9	14			
210102	23	2	210279	44		211528	9	22			
210117	5	33	210282A	19	20	211529	9	19			
210124	15	17	210283	17	24	211530	9	16			
210125	15	16	210284	17	22	211531	31	3			
210127	19	15	210285	17	26	211533	9	13			
210129	19	16	210287	17	20	211636	27	1			
210130	19	17	210288	15	37	211639	33	22			
210136	19	6	210289	15	39	211657	27	31			
210137	19	1	210292	17	18	211802A	19	10			
210138	19	4	210293	17	16	211804	19	11			
210139	19	2	210294	15	23	211855	7	26			
210140	19	13	210296	15	34	211857	44				
210141	19	22	210297	15	35	211858	23	31			
210142	23	1	210298	15	26	211858	44				
210143	23	10	210299	15	31	211859	23	39			
210144	23	5	210300	17	29	211859	44				
210145	23	7	210302	17	34	211860	27	8			
210146	23	8	210303	17	36	211861	35	28			
210147	23	21	210304	17	31	211862	35	8			
210148	23	22	210306	17	40	211862	35	32			
210152	21	2	210307	17	33	211958	7	15			
210153	23	34	210308	17	38	211959-HD	7	13			
210154	23	20	210309	17	1	211977	5	1			
210155	23	33	210310	17	3	212179	21	39			
210156	23	41	210311	17	43	212186	11	5			
210157	23	45	210314	25	7	212188	31	30			
210158	23	47	210315C	25	16	212279A	3	31			
210159	23	52	210316A	25	20	212327-FD	3	19			
210160	23	50	210319	13	6	212627	44				
210161	21	5	210321	27	16	212628	44				
210162	21	8	210322	27	17	212629	44				
210163	21	10	210323	27	18	212630	44				
210164	21	11	210326	27	15	212634	31	41			
210166	21	17	210329	27	5	212635-ME	33	1			
210167	21	19	210335	27	4	212636	7	45			
210168	21	22	210337	27	25	212638	13	39			
210170	21	23	210343	23	25	212638	44				
210171	21	27	210357	15	29	212639	13	41			
210172	21	33	210357	41	23	212639	44				
210173	25	5	210357	44		212640	25	14			
210175	25	9	210510	31	38	212641	35	6			
210180	25	22	210511	11	29	212642	33	17			
210183	5	17	210517	27	22	212654	17	12			
210183	25	28	210520	31	47	212860	44				
210184	25	25	210521	31	45	212861-16	44				
210190	31	28	210523	39	4	212862-16	44				
210192	31	35	210525	3	5	212863	29	1			
210193	31	33	210528	3	12	212863	44				
210194	31	36	210529	13	1	212955-FB	7	10			
210198	31	26	210532	21	37	212972-91	31	1			
210199	31	27	210533	21	36	212976	31	2			
210200	31	18	210534	21	34	212978-91	31	5			
210201-FD	31	19	210535	21	32	212979	31	6			
210202	31	31	210539	33	25	212980	31	7			
210211	31	42	210583	3	29	212981	31	9			
210212	31	48	210585	15	4	212982	31	10			
210214	33	18	210586	15	33	212984	7	43			
210218-HD	3	1	210679	3	32	212987	9	15			
210219-HD	3	7	210700	21	25	212988	27	7			
210220	3	9	210727	27	13	212998	31	32			
210221	7	24	210728	27	11	213578	31	11			
210223	7	17	210736	15	9	213579	31	12			
210224	7	22	210749	13	14	213633	31	37			
210228-PB	9	1	210750	13	17	230047A	3	34			
210229	11	33	210751	13	18	240052	3	4			

www.collegesewing.co.uk



www.collegesewing.co.uk



www.collegesewing.com



www.collegesewing.co.uk

■ PEGASUS
SEWING MACHINE MFG.
CO., LTD.®

