



PEGASUS

INDUSTRIAL

SEWING MACHINE

PARTS LIST

MODEL

DC-MS230

DC-MS205

DC-MS220

DC-MS250

HIGH SPEED

2 NEEDLES

5 THREADS

**SAFETY-STITCH
MACHINES**



MODEL DC-MS230

PEGASUS SEWING MACHINE MFG. CO., LTD.

www.collegesewing.com



IN ORDERING PARTS

This list has been arranged to simplify ordering repair parts for DC-MS series machines on the basis of model DC-MS230.

Various sections of the mechanisms are shown on each page. On the page opposite the illustration will be found a listing of the parts with their reference numbers, parts numbers, name and the number of pieces required.

A parts whose number is marked with an asterisk, e.g. *202075A, Page 3, is not recommended for the individual replacement, so complete assembly or sub-assembly should be ordered.

Organization parts for all models, whose numbers are marked with two asterisks, e.g. **200711, Ref. No.31, Page 5, are again illustrated and listed on the pages 26-29 so that the parts numbers of relating other organization parts for repair or conversion may be obtained.

If the parts are used exclusively for certain models only, such machine models are specified in the column "Name" listed on Page 3 to 23.

In ordering parts from this list, USE ONLY the PARTS NUMBER in the second column. Reference number should never be used in ordering parts.

This Parts List applies to the machines manufactured in August, 1979.

部品表御利用に際して

本パーツ・リストは、DC-MS230型ミシンを基に、DC-MSシリーズ・ミシンの修理用部品を容易にご利用戴けるよう編集されています。

機構別に各頁に収録され、部品図解頁の反対頁には参照番号、部品番号、名称、使用数量の順で記載されています。

部品番号の左に*印の付された部品は、複数の部品が組合された部品の一部で個々に販売はしていません。ご入用の際はこれらの部品が組合された部品をご注文下さい。(例：3頁、*202075A、クランクシャフト・*200605、クランクシャフト油受リングが組合されて、参照番号7、202074、クランクシャフト(組)・となっています。)

印の付された部品はゲージ・パーツです。ゲージ・パーツは26頁～27頁に図解を、28頁～29頁に機種別、用途別(使用糸別)に該当ゲージ・パーツの一覧表を記載していますので、この一覧表を参照して下さい。(例：5頁、参照番号31、部品番号200711針棒)

本パーツ・リストの3頁～23頁にわたって、名称欄に使用機種名を指定しています部品は、指定された機種のみを使用される部品であります。したがって使用機種名を指定していない部品は、全機種に共用できます。

本パーツ・リストに基き部品ご注文の際、参照番号は絶対に使用されず、部品番号のみを明示して下さい。

本パーツ・リストは1979年8月現在製造中のミシンをもとに作成されています。

CONTENTS

	目次	PAGE 頁
ARM-BED & CRANKSHAFT MECHANISM	アーム・ベッド、主軸機構.....	2 ~ 3
NEEDLE DRIVE MECHANISM	針棒機構.....	4 ~ 5
RIGHT & LEFT LOOPER DRIVE MECHANISM	大・小ルーパー機構.....	6 ~ 7
(1) DOUBLE CHAINSTITCH LOOPER DRIVE MECHANISM	二重環ルーパー機構(1).....	8 ~ 9
(2) DOUBLE CHAINSTITCH LOOPER DRIVE MECHANISM	二重環ルーパー機構(2).....	10 ~ 11
FEED MECHANISM	送り機構.....	12 ~ 13
PRESSER FOOT & LIFT MECHANISM	押エ機構.....	14 ~ 15
UPPER & LOWER KNIFE MECHANISM	上・下メス機構.....	14 ~ 15
(1) PUMP LUBRICATING MECHANISM	給油機構(1).....	16 ~ 17
(2) PUMP LUBRICATING MECHANISM	給油機構(2).....	18 ~ 19
(1) MACHINE FRAME AND MISCELLANEOUS COVERS	カバー・外装機構(1).....	20 ~ 21
(2) MACHINE FRAME AND MISCELLANEOUS COVERS	カバー・外装機構(2).....	22 ~ 23
LIST OF ORGANIZATION PARTS	ゲージ・パーツ表.....	26 ~ 29
ACCESSORIES	付属品.....	30 ~ 31
NUMERICAL INDEX OF PARTS	部品番号索引.....	32 ~ 33
		30 ~ 31

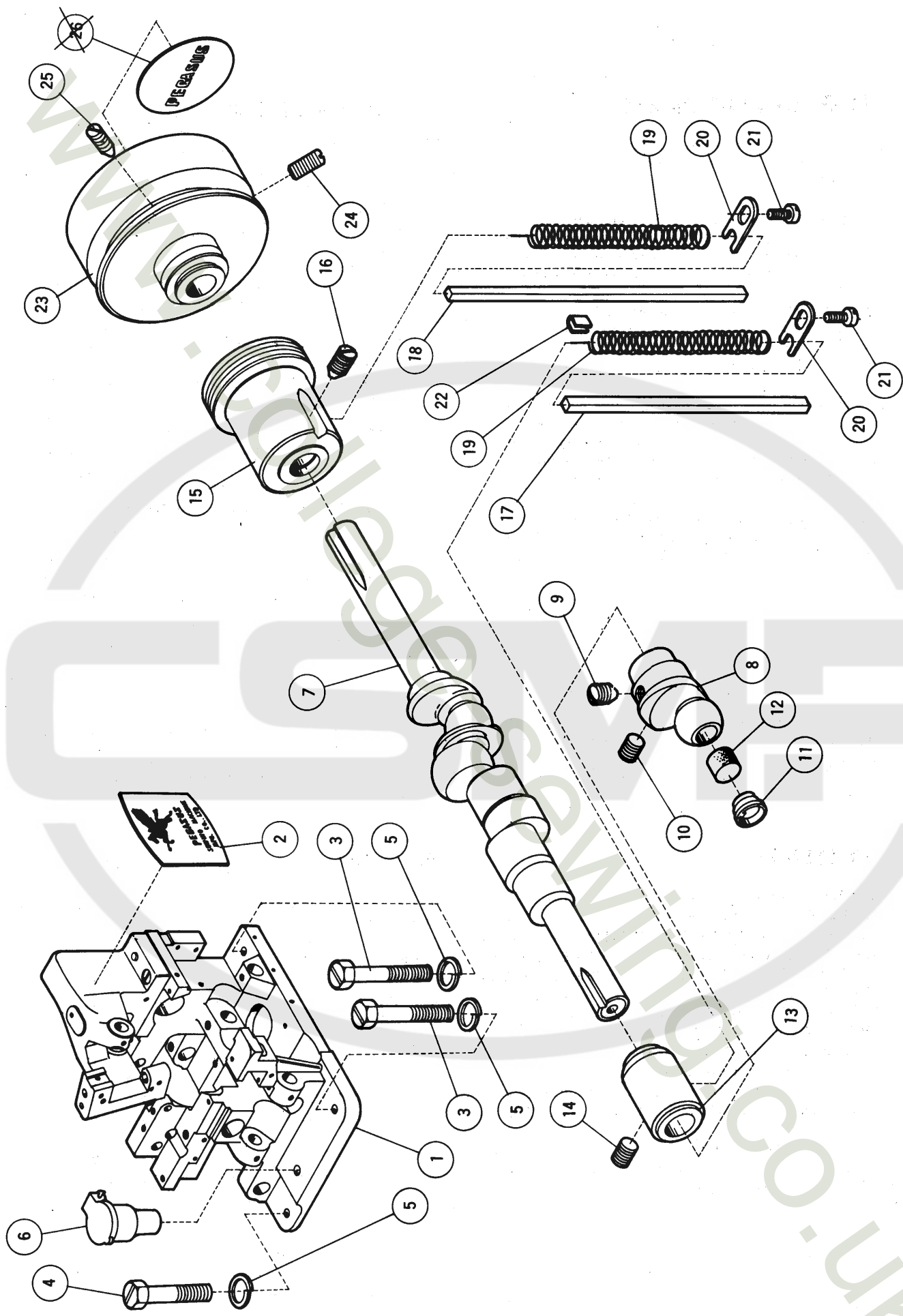

ARM-BED & CRANKSHAFT MECHANISM

アーム・ベッド, 主軸機構

Ref. No. 参照番号	Parts No. 部品番号	Name	名 称	Qt. 数量
1	202070	Machine arm-bed, complete with 202001, 202071, 1936x2 & 13795x2. (DC-MS205M, 220, 230 & 250 only)	アーム・ベッド(組)202001, 202071, 1936×2, 13795×2 トノ組 (DC-MS205, 220, 230, 250用)	1
	*202001	Machine arm	アーム	1
	*202071	Machine bed	ベッド	1
	1936A	Machine arm-bed screw	アーム・ベッド締付ネジ	2
	137950	" " hinge pin	" " テーパーピン	2
2	202046	Brand plate	銘板	1
3	5132	Machine bed bolt (long)	ベッド取付ボルト(長)	2
4	5133	" " " (short)	" " (短)	1
5	202045 202051	" " " washer	" " 座金	3
6	200211	Oil filler cup	オイルカップ	1
7	202074	Crankshaft, complete with 202075A & 200605. (DC-MS205, 220, 230 & 250 only)	クランクシャフト(組)202075A, 200605 /組 (DC-MS205, 220, 230, 250用)	1
	*202075A	Crankshaft	クランクシャフト	1
	*200605	" oil ring	" 油受リング	1
8	200703	" crank	エキセンクランク	1
9	5058	" " position screw	" 止メジ(先有)	1
10	2913-1	" " screw	" " (先無)	1
11	200607	" " oil plug	" 油栓	1
12	200389	" " " wick	" 給油フェルト	1
13	200707	" bushing (DC-MS205, 220, 230 & 250 only)	小ブッシュ (DC-MS205, 220, 230, 250用)	1
14	2022-3	" " screw	" 止ネジ	1
15	202006	" flanged bushing	大ブッシュ	1
16	2368	" " " screw	" 止ネジ	1
17	200633	" bushing oil wick	小ブッシュ給油フェルト	1
18	202024	" flanged bushing oil wick	大ブッシュ給油フェルト	1
19	202025	" bushing and flanged bushing oil wick spring	大、小ブッシュ給油フェルト押エバネ	2
20	202026	" " " flanged bushing oil wick spring clamp	" " " " " 止板	2
21	4009-1	" " " flanged bushing oil wick spring clamp screw	" " " " " 止ネジ	2
22	200664	" " " oil wick clamp	小ブッシュ給油フェルト調節金	1
23	202007	Pulley	プーリー	1
24	5051	" screw	" 止ネジ(先無)	1
25	5052	" position screw	" " (先有)	1
26	201019 202019	" name plate	" 銘板	1

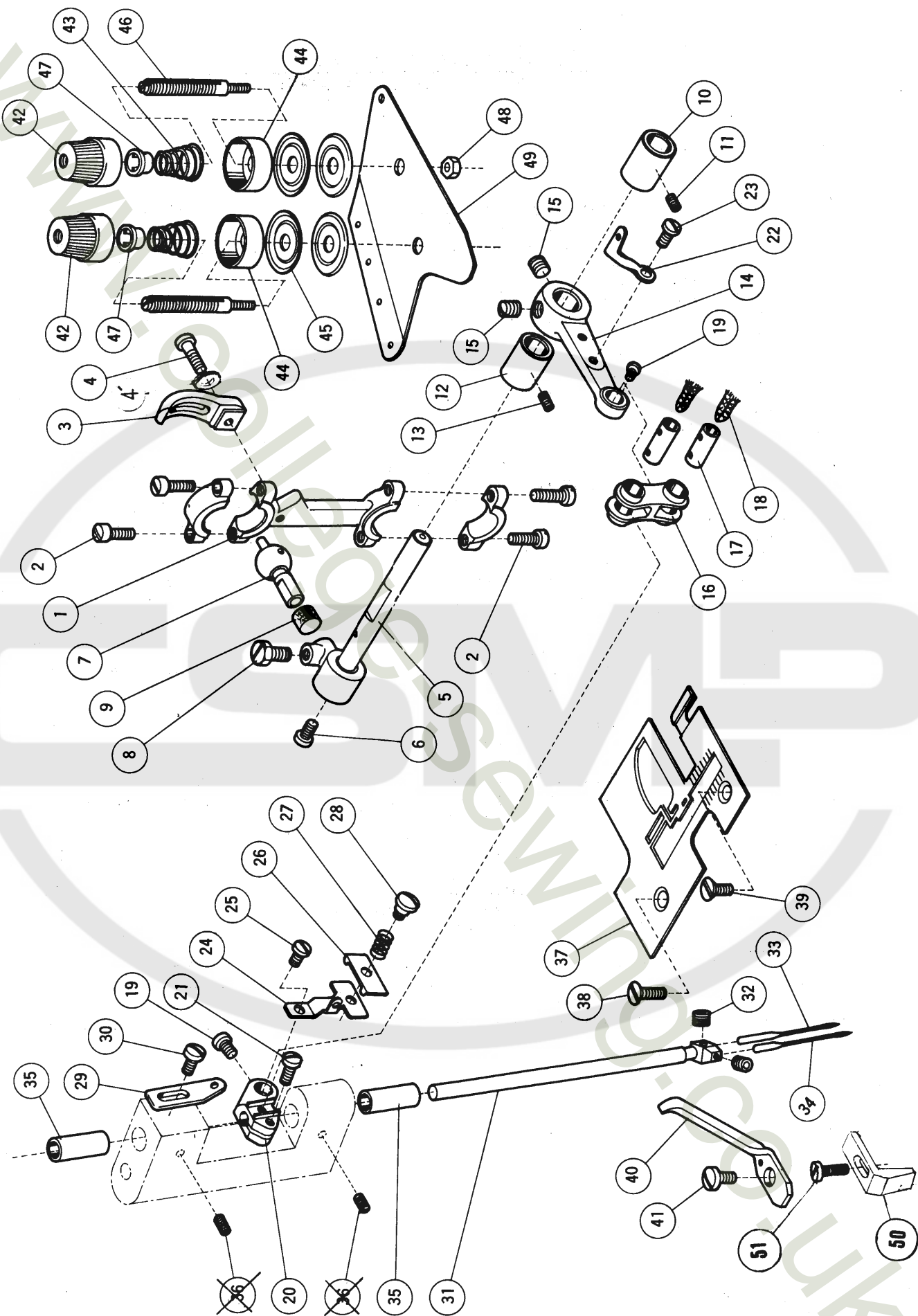

NEEDLE DRIVE MECHANISM

針 棒 機 構

Ref. No. 参照番号	Parts No. 部品番号	Name	名称	Qt. 数量
1	200034	Needle bar connection, complete with 200033 & 2213x4	大ロッド(組)200033,2213-1×4トノ組	1
2	200033	" " connection	〃	1
3	2213-1	" " " cap screw	〃 蓋止ネジ	4
4	137130	" " " guide	〃 振り止メ	1
4	5010	" " " " screw	〃 〃 止ネジ	1
4	200821	" " " " " screw	〃 〃 〃 座金	1
5	200534	" " drive crankshaft	針棒クランク軸	1
6	1234	" " " " plug screw	〃 蓋ネジ	1
7	200265	" " " " ball stud	針棒後クランク球	1
8	2022-4	" " " " " " screw	〃 止ネジ	1
9	200389	" " " " " " oil wick	〃 給油フェルト	1
10	200037	" " " " bushing (front)	針棒クランク軸ブッシュ前	1
11	1457	" " " " " " screw	〃 〃 〃 止ネジ	1
12	202010	" " " " " (rear)	〃 〃 〃 後	1
13	1457	" " " " " " screw	〃 〃 〃 止ネジ	1
14	200652	" " " " crank	針棒前クランク	1
15	5385 2022	" " " " " screw	〃 止ネジ	2
16	200653	" " connecting link	針棒リンク	1
17	200654	" " " " pin	〃 ピン	2
18	202177	" " " " " oil wick	〃 〃 給油紐	2
19	1222	" " " " " screw	〃 〃 止ネジ	2
20	200655	" " " " bracket	針棒抱キ	1
21	1170-3	" " " " " screw	〃 止ネジ	1
22	200531	" thread take-up	上糸振り糸道	1
23	1196	" " " " screw	〃 止ネジ	1
24	200709	" " retainer bracket	小調子台	1
25	1186	" " " " " screw	〃 止ネジ	1
26	192070	" " " " guide	小調子皿	1
27	1920 70-1	" " " " spring	小調子バネ	1
28	9070-2	" " " " " screw	〃 止ネジ	1
29	137101	" " eyelet	上糸道	1
30	1216	" " " " " screw	〃 止ネジ	1
31	**200711	" bar, complete with 141122, 200713 & 5292x2 (DC-MS230 & 230D only)	針棒(組)141122,200713,5292×2ノ組 (DC-MS230,230D用)	1
	*141122	" bar	針棒	1
	*200713	" clamp	針株	1
32	5292	" " screw	針止ネジ	2
33	DC×1	Needle for overlock stitch or right needle	針	1
34	DM×13	" for double chain stitch or left needle	〃	1
35	137123	" bar bushing	針棒ブッシュ	2
36	1457	" " " " screw	〃 〃 止ネジ	2
37	**200715A	" plate	針板(DC-MS230用,(カタン糸用))	1
38	1732	" " " screw (long)	〃 止ネジ(長)	1
39	5061	" " " (short)	〃 〃 (短)	1
40	200716	" guard	針受	1
41	1202	" " " screw	〃 止ネジ	1
42	201035A	" thread tension nut	針糸調子ナット	2
43	201037	" " " " spring	〃 バネ	2
44	201039	" " " " " cup	〃 〃 受皿	2
45	101111	" " " " disc	〃 皿	4
46	1817-2A	" " " " post	〃 棒	2
47	202278	" " " " spring bushing	〃 〃 ナット止パイプ	2
48	3044	" " " " post nut	〃 〃 ナット	1
49	141105	" " " " guide	上糸調子台	1
50	202184	" " " " " "	金針受(三重環針用)	1
51	2922	" " " " " "	〃 止ネジ	1

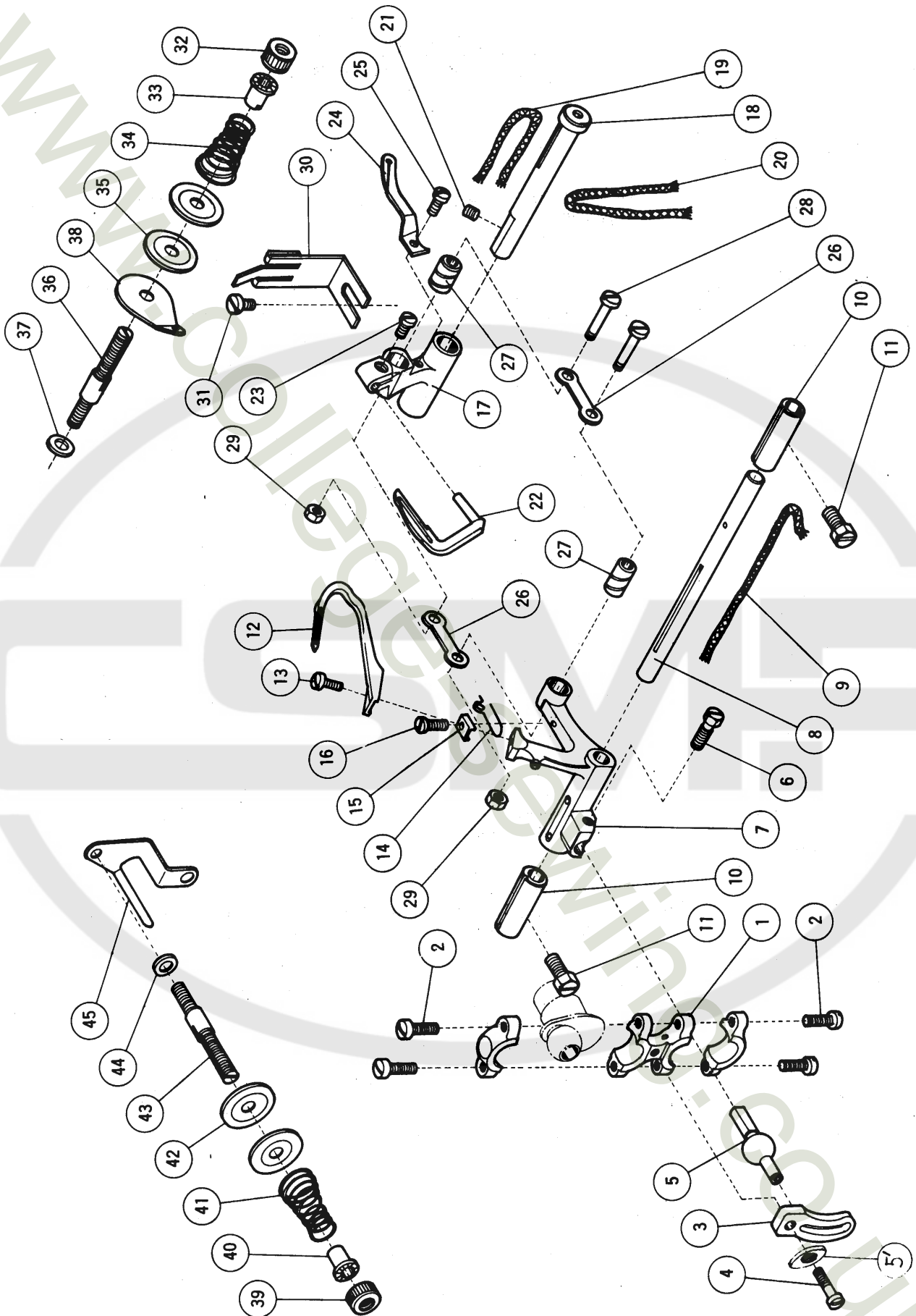

RIGHT & LEFT LOOPER DRIVE MECHANISM

大・小 ル ー パ ー 機 構

Ref. No.	Parts No.	Name	名 称	Qt.
参照番号	部品番号			数量
1	200618	Right looper drive connection	小ロッド	1
2	2213-1	" " " " cap screw	〃 蓋止ネジ	4
3	137130	" " " " guide	〃 振り止メ	1
4	5010	" " " " " screw	〃 〃 止ネジ	1
5	137121	" " " " ball stud	〃 球	1
5'	200821	" " " " " " " screw	〃 振り止メ止ネジ座金	1
6	2022-4	" " " " " " " screw	〃 〃 止ネジ	1
7	202135	" " " lever	大ルーパー台	1
8	200620	" " " shaft	〃 ピン	1
9	202176	" " " " oil wick	〃 〃 給油紐	1
10	137409	" " " " bushing	割ブッシュ	2
11	2022-4	" " " " " " " screw	〃 〃 止ネジ	2
12	**137301	" " " looper	大ルーパー	1
13	1196	" " " screw	〃 止ネジ	1
14	137307A	Left looper thread eyelet	大ルーパー台糸道	1
15	200947	" " " " " " clamp	〃 板金	1
16	2922	" " " " " " screw	〃 〃 止ネジ	1
17	200624	" " " lever	小ルーパー台	1
18	200625	" " " shaft	〃 ピン	1
19	202176	" " " " " oil wick	〃 〃 給油紐	1
20	202179	" " " " " wick	〃 〃 給油紐	1
21	2022-3	" " " " " " screw	〃 〃 止ネジ	1
22	**137302	" " " looper	小ルーパー	1
23	5053	" " " screw	〃 止ネジ	1
24	200717	Right looper thread take-up	大ルーパー糸道	1
25	1196	" " " " " " screw	〃 〃 止ネジ	1
26	200621A	Looper connecting link	ルーパーリンク	2
27	200622A	" " " " " bushing	〃 ブッシュ	2
28	200623A	" " " " " " screw	〃 締付ネジ	2
29	3044	" " " " " " nut	〃 〃 ナット	2
30	137104	Right looper thread staple	三又糸道	1
31	1216	" " " " " " screw	〃 止ネジ	1
32	3056	" " " " " tension nut	前糸調子ナット	1
33	101113	" " " " " spring bushing	〃 〃 止パイプ	1
34	137115	" " " " " spring	〃 バネ	1
35	101111	" " " " " disc	〃 皿	2
36	1817-2A	" " " " " post	〃 棒	1
37	137142	" " " " " " washer	〃 〃 座金	1
38	137106	" " " " " " guide	〃 〃 台	1
39	3056	Left looper thread tension nut	裏糸調子ナット	1
40	101113	" " " " " " spring bushing	〃 〃 止パイプ	1
41	137114	" " " " " " spring	〃 バネ	1
42	101111	" " " " " " disc	〃 皿	2
43	1817-2A	" " " " " " post	〃 棒	1
44	137142	" " " " " " washer	〃 〃 座金	1
45	200718	" " " " " " guide	〃 〃 台	1

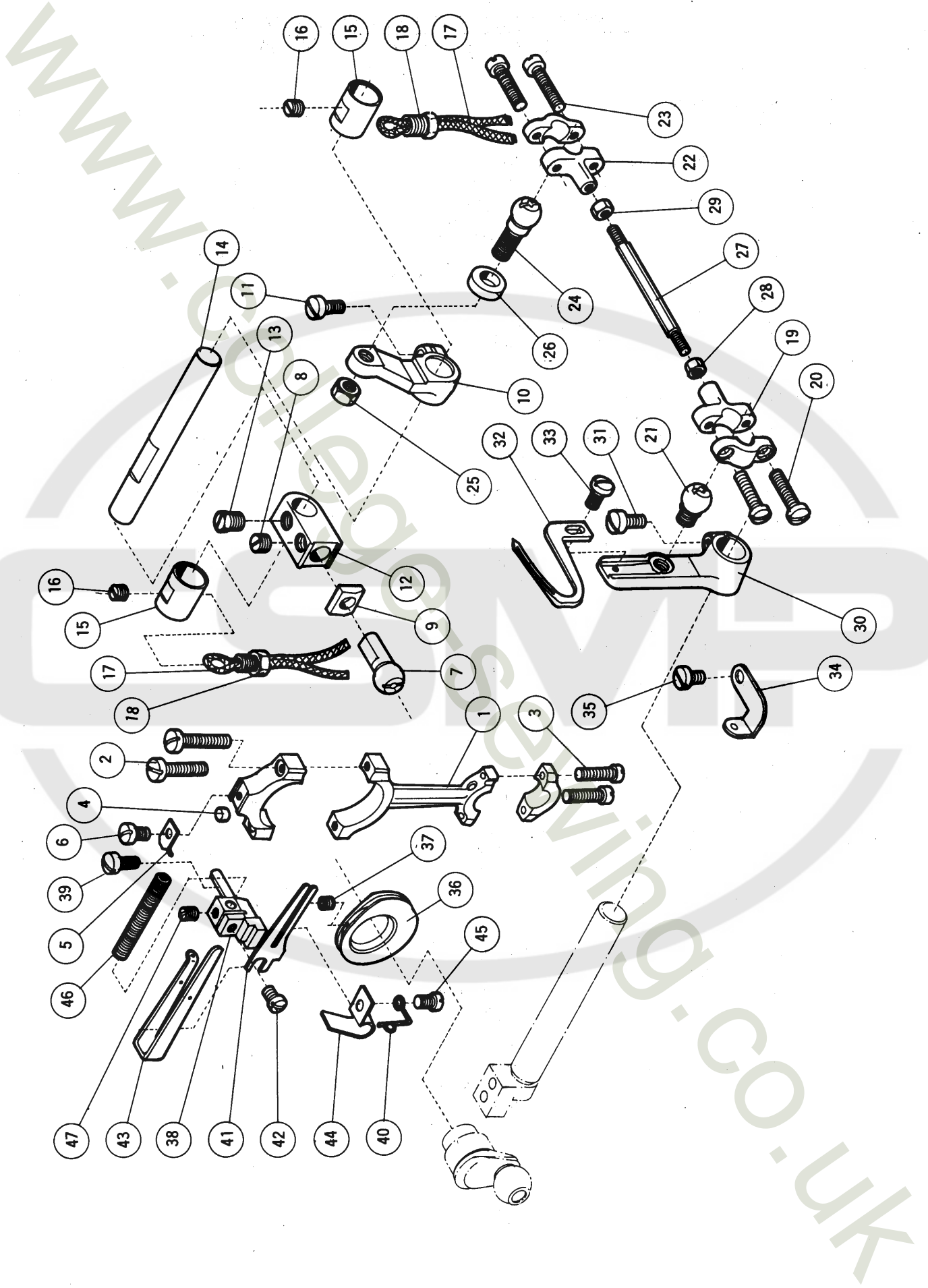

(1) DOUBLE CHAINSTITCH LOOPER DRIVE MECHANISM

二重環ルーパー機構 (1)

Ref. No.	Parts No.	Name	名称	Qt.
参照番号	部品番号			数量
	202076	Looper drive connection, complete with 202077A, 2213-1x2 & 1170x2	二重環ルーパー振り大ロッド(組)202077 A, 2213-1×2, 1170×2 ノ組	1
1	202077 A	" " connection	" "	1
2	2213-1	" " " cap screw (large)	" " 蓋止ネジ(大)	2
3	1170	" " " " (small)	" " (小)	2
4	202081	" " " oil wick	" " 給油フェルト	1
5	202083A	" " " " " spring	" " 給油紐押エバネ	1
6	1216	" " " " " screw	" " " 止ネジ	1
7	200756	" " " ball stud	" " 球(小)	1
8	2022	" " " " " screw	" " 止ネジ	1
9	200757	" " " guide	" " 振り止メファイバー	1
10	200758	" " crank (front)	二重環ルーパー振りクランク(前)	1
11	1156	" " " " screw	" " " 止ネジ	1
12	200759	" " " (rear)	" " (後)	1
13	2022-4	" " " " screw	" " 止ネジ	1
14	200760	" " " shaft	二重環ルーパー振りクランク軸	1
15	200761	" " " " bushing	" " ブッシュ	2
16	2022	" " " " screw	" " 止ネジ	2
17	202176	" " " " oil wick	" " 給油紐	2
18	200742	" " " " " screw	" " 止ネジ	2
19	202138	" connecting rod end (left), complete with 1174x2	二重環ルーパー振り小ロッド(左)1174×2 トノ組	1
20	1174	" " " " cap screw	" " 蓋止ネジ	2
21	200401	" " " " ball stud	" " 球(左)	1
22	200396	" " " " (right), complete with 1174x2	" " (右)1174×2 トノ組	1
23	1174	" " " " cap screw	" " 蓋止ネジ	2
24	200400	" " " " ball stud	" " 球(右)	1
25	3018	" " " " " nut	" " 止ナット	1
26	200398	" " " " guide	" " 振り止メ	1
27	200767	" " rod	二重環ルーパー連結棒	1
28	3091	" " " nut (left)	" " ナット(左)	1
29	3092	" " " " (right)	" " (右)	1
30	200782	" lever	二重環ルーパー台	1
31	5002 5064	" " clamp screw	" 止ネジ	1
32	**200785	Looper	二重環ルーパー	1
33	1202	" screw	" 止ネジ	1
34	202136	" thread eyelet	" 糸道	1
35	1202	" " " screw	" " 止ネジ	1
36	200799B	" " take-up	下糸調節器	1
37	5292	" " " screw	" 止ネジ	1
38	200787 A	" " cast-off bracket	下糸調節台	1
39	5064	" " " " screw	" 止ネジ	1
40	202137	" " guide	" 糸道	1
41	200798B	" " cast-off	下糸サバキ	1
42	1234	" " " screw	" 止ネジ	1
43	200795A	" " staple	二又糸道	1
44	200793	" " " lock spring	" 押エバネ	1
45	1202	" " " " " screw	" " 止ネジ	1
46	200719	" " guide tube	糸道パイプ	1
47	1457-1	" " " " screw	" 止ネジ	1

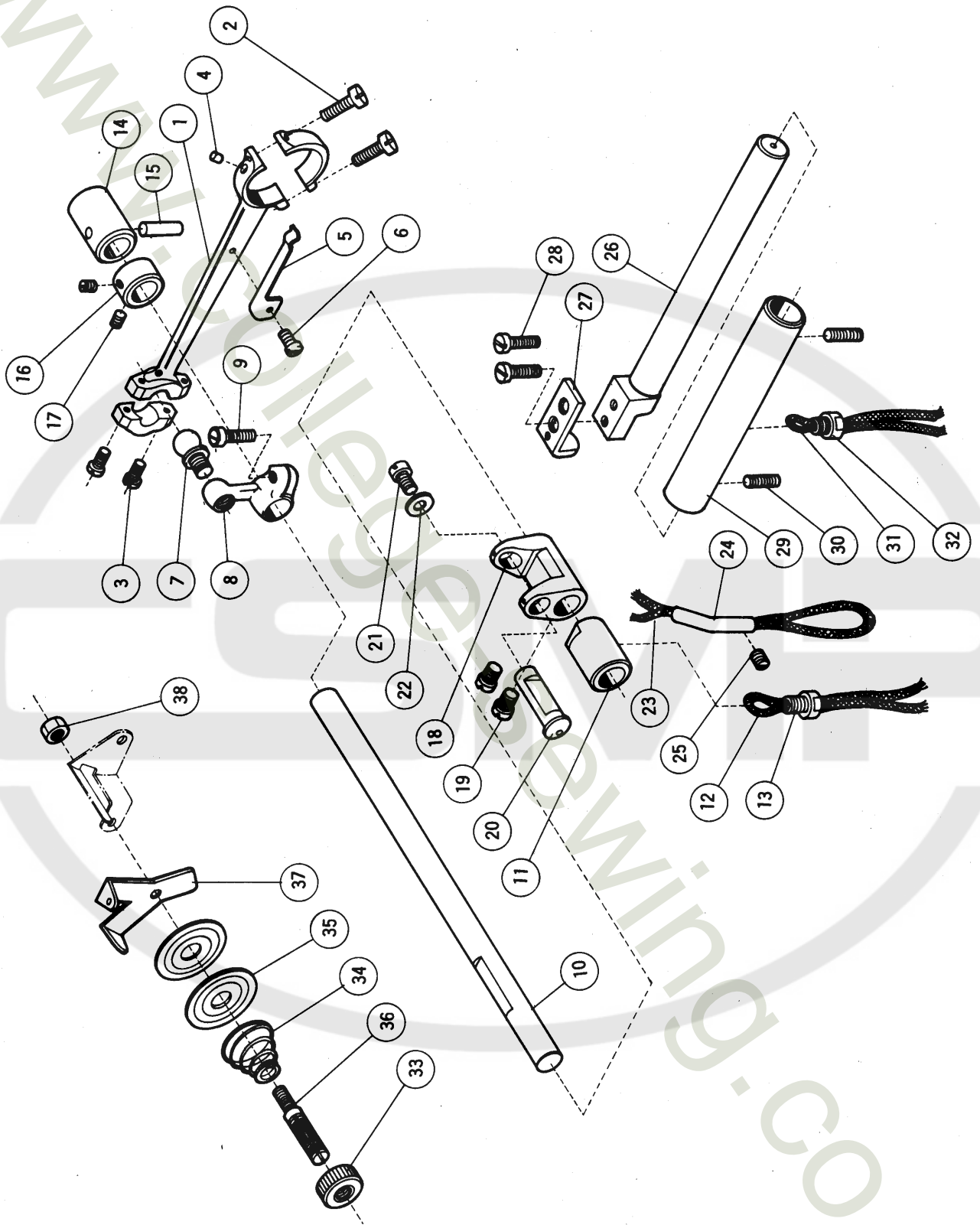

(2) DOUBLE CHAINSTITCH LOOPER DRIVE MECHANISM

二重環ルーパー機構 (2)

Ref. No.	Parts No.	Name	名称	Qt.
参照番号	部品番号			数量
1	200764 200763	Looper avoiding connection, complete with 5002x2 & 2918x2.	二重環ルーパー前後ロッド(組)5002×2, 2918×2 トノ組	1
2	5002	" " " cap screw (large)	〃 〃 蓋止ネジ(大)	2
3	2918	" " " " (small)	〃 〃 (小)	2
4	202047	" " " oil wick	〃 〃 給油フェルト	1
5	200737	" " " " " spring	〃 〃 給油紐押エバネ	1
6	1186	" " " " " " screw	〃 〃 〃 〃 止メジ	1
7	200770	" " " ball stud	〃 〃 球	1
8	200771	" " " crank	二重環ルーパー前後振りクランク	1
9	5002	" " " clamp screw	〃 〃 止ネジ	1
10	200772	" " " shaft	二重環ルーパー前後振りシャフト	1
11	200773	" " " bushing (left)	〃 〃 ブッシュ(左)	1
12	202176	" " " " " oil wick	〃 〃 〃 〃 給油紐	1
13	200742	" " " " " " " screw	〃 〃 〃 〃 止ネジ	1
14	200773	" " " " " (right)	〃 〃 〃 (右)	1
15	200741	" " " " " oil wick	〃 〃 〃 給油フェルト	1
16	200775	" " " collar	〃 〃 カラー	1
17	1457-1	" " " " " screw	〃 〃 〃 止ネジ	2
18	200776	" " " link	二重環ルーパー前後振りリンク	1
19	2237	" " " screw	〃 〃 止ネジ	2
20	200777	" " " pin	〃 〃 ピン	1
21	5317-1196	" " " " " plug screw	〃 〃 〃 蓋ネジ	1
22	202757A	" " " " " thrust washer	〃 〃 〃 スラストワッシャー	1
23	202176	" " " " " oil wick	〃 〃 〃 給油紐	1
24	200632	" " " " " tube	〃 〃 〃 給油管	1
25	1457	" " " " " screw	〃 〃 〃 止ネジ	1
26	200779	" " " lever shaft	二重環ルーパー台シャフト	1
27	200780	" " " " " guide	〃 〃 L形	1
28	1175-3	" " " " " screw	〃 〃 〃 止ネジ	2
29	200781	" " " " " bushing	〃 〃 ブッシュ	1
30	1435	" " " " " screw	〃 〃 〃 止ネジ	2
31	202176	" " " " " oil wick	〃 〃 〃 給油紐	1
32	200742	" " " " " " " screw	〃 〃 〃 〃 止ネジ	1
33	3056	" " " thread tension nut	下糸調子ナット	1
34	167077	" " " " " spring	〃 バネ	1
35	101111	" " " " " disc	〃 皿	2
36	167072	" " " " " post	〃 棒	1
37	200204	" " " " " guide	〃 台	1
38	3044	" " " " " post nut	〃 棒取付ナット	1

WWW

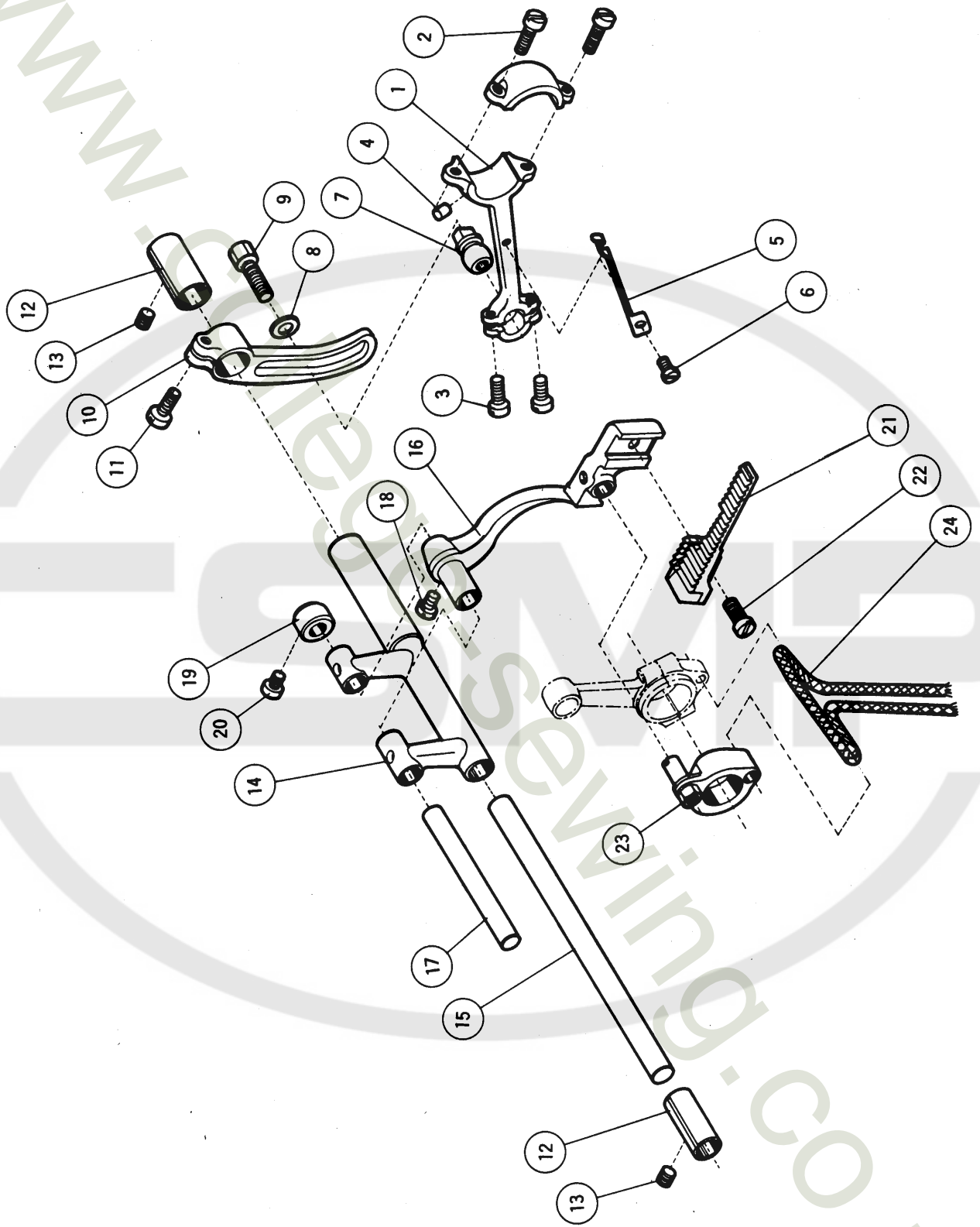

FEED MECHANISM

送 り 機 構

Ref. No. 参照番号	Parts No. 部品番号	Name	名 称	Qt. 数量
1	200503	Feed drive connection, complete with 5002x2 & 5003x2	送り前後ロッド(組) 5002×2, 5003×2 トノ組	1
2	5002	" " " cap screw (large)	〃 蓋止ネジ(大)	2
3	5003	" " " " " (small)	〃 " (小)	2
4	202047	" " " oil wick	〃 給油フェルト	1
5	200737	" " " " " spring	〃 給油紐押エバネ	1
6	1186	" " " " " " screw	〃 " " 止ネジ	1
7	137419	" " " ball stud	〃 球	1
8	137142	" " " " " washer	〃 〃座金	1
9	5001	" " " " " screw	〃 〃止ネジ	1
10	200322	" regulating segment	送り調節器	1
11	1156	" " " clamp sprew	〃 抱締ネジ	1
12	137409	" rocker pin bushing (One piece only requires for DC-MS205D, 220D, 230D & 250D)	割ブッシュ (DC-MS205D, 220D, 230D, 250Dハ所要数1ケ)	2
13	2022-3	" " " " " screw	〃 〃 止ネジ	2
14	140402	" rocker	送りロックシャフト	1
15	137417	" " " pin	送り台シャフト	1
16	202088	" bar	送りに取付台	1
17	137442	" " " hinge pin	〃 ピン	1
18	2237	" " " " " screw	〃 〃 止ネジ	1
19	137442-1	" " " " " collar	〃 〃 カラー	DC-MS205, 1
20	5053	" " " " " " screw	〃 〃 〃 止ネジ	220, 230, 1 250用
21	* *200723A	" dog	送り歯	1
22	1175-2	" " " screw	〃 止ネジ	1
23	200627	" lift connection, complete with 200628 & 198106 200629 3044	送り上下ダルマ(組) 200628, 198106 3044 トノ組	1
	*200628	" " " " " screw	〃 〃 芯ネジ	1
3044	* 200629	" " " " " nut	〃 〃 ナット	1
24	202176	" " " oil wick (also used for upper knif drive connection)	〃 給油紐 (上メスロッド共用)	1

★ The parts, whose reference numbers are 14 to 24,
are used only for model DC-MS205, 220, 230 & 250.

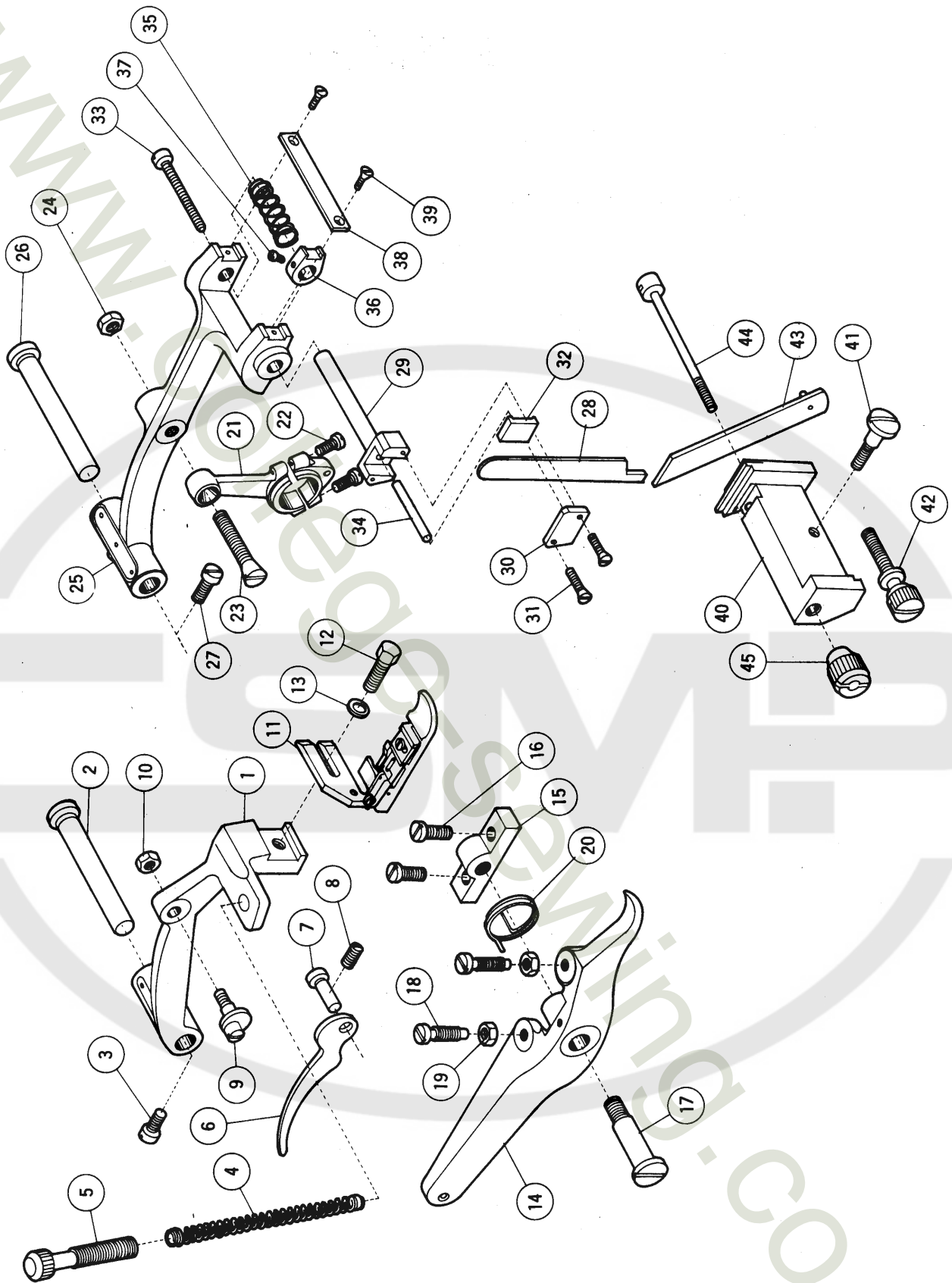

PRESSER FOOT & LIFT MECHANISM

押 工 機 構

Ref. No.	Parts No.	Name	名 称	Qt.
参照番号	部品番号			数量
1	137140	Presser arm (DC-MS205, 220, 230 & 250 only)	押エ台 (DC-MS205, 220, 230, 250用)	1
2	137552	" " pivot stud	〃 ピン	1
3	2213	" " " " screw	〃 〃 止ネジ	1
4	137141	" " spring	〃 バネ	1
5	2371	" " regulating thumb screw	〃 〃 調節ネジ	1
6	137143	Hand lift lever	押エ手揚ゲ	1
7	5056	" " " " pin	〃 ピン	1
8	1458	" " " " screw	〃 〃 止ネジ	1
9	2370	" " " " eccentric screw	〃 エキセンネジ	1
10	3044	" " " " " " nut	〃 ナット	1
11	**200731	Presser foot, complete	押エ(組)	1
12	2308	" " " " screw	〃 止ネジ	1
13	137142	" " " " washer	〃 〃 座金	1
14	137146	Foot lift lever	押エ足揚ゲ	1
15	137145A	" " " " " " bracket	〃 台	1
16	2213	" " " " " " screw	〃 〃 止ネジ	2
17	2285	" " " " " " pivot stud	〃 取付ネジ	1
18	2133	" " " " " " adjust screw	〃 調節ネジ	2
19	3044	" " " " " " " " nut	〃 ナット	2
20	137147	" " " " " " spring	〃 バネ	1

UPPER & LOWER KNIFE MECHANISM

上・下 メ ス 機 構

21	200631	Upper knife drive connection, complete with 1174x2	上メスロッド(組) 1174×2 トノ組	1
22	1174	" " " " " " cap screw	〃 蓋止ネジ	2
23	2366-2	" " " " " " stud	〃 テーパーネジ	1
24	3018	" " " " " " " " nut	〃 ナット	1
25	200725A	" " " " lever	上メス台	1
26	137552	" " " " " " pin	〃 ピン	1
27	2133-1	" " " " " " screw	〃 〃 止ネジ	1
28	**138559	" " knife	上メス	1
29	138555A	" " " " carrier	上メス抱キ	1
30	138555-1	" " " " " " cap	〃 蓋	1
31	5224	" " " " " " screw	〃 〃 止ネジ	2
32	138556	" " " " " " clamp	上メス押し	1
33	1132	" " " " " " screw	〃 ネジ	1
34	137560	" " " " " " pin	〃 ピン	1
35	137558	" " " " " " spring	〃 バネ	1
36	137554	" " " " " " guide	上メス案内	1
37	1222	" " " " " " screw	〃 止ネジ	1
38	137553	" " " " " " bar	〃 板	1
39	5259	" " " " " " screw	〃 〃 止ネジ	2
40	200726A	Lower knife carrier	下メス台	1
41	5065	" " " " " " screw	〃 止ネジ	1
42	5070	" " " " " " adjust screw	〃 調節ネジ	1
43	**137562	" " knife	下メス	1
44	137563	" " " " " " clamp	〃 止ピン	1
45	5069	" " " " " " nut	〃 ナット	1

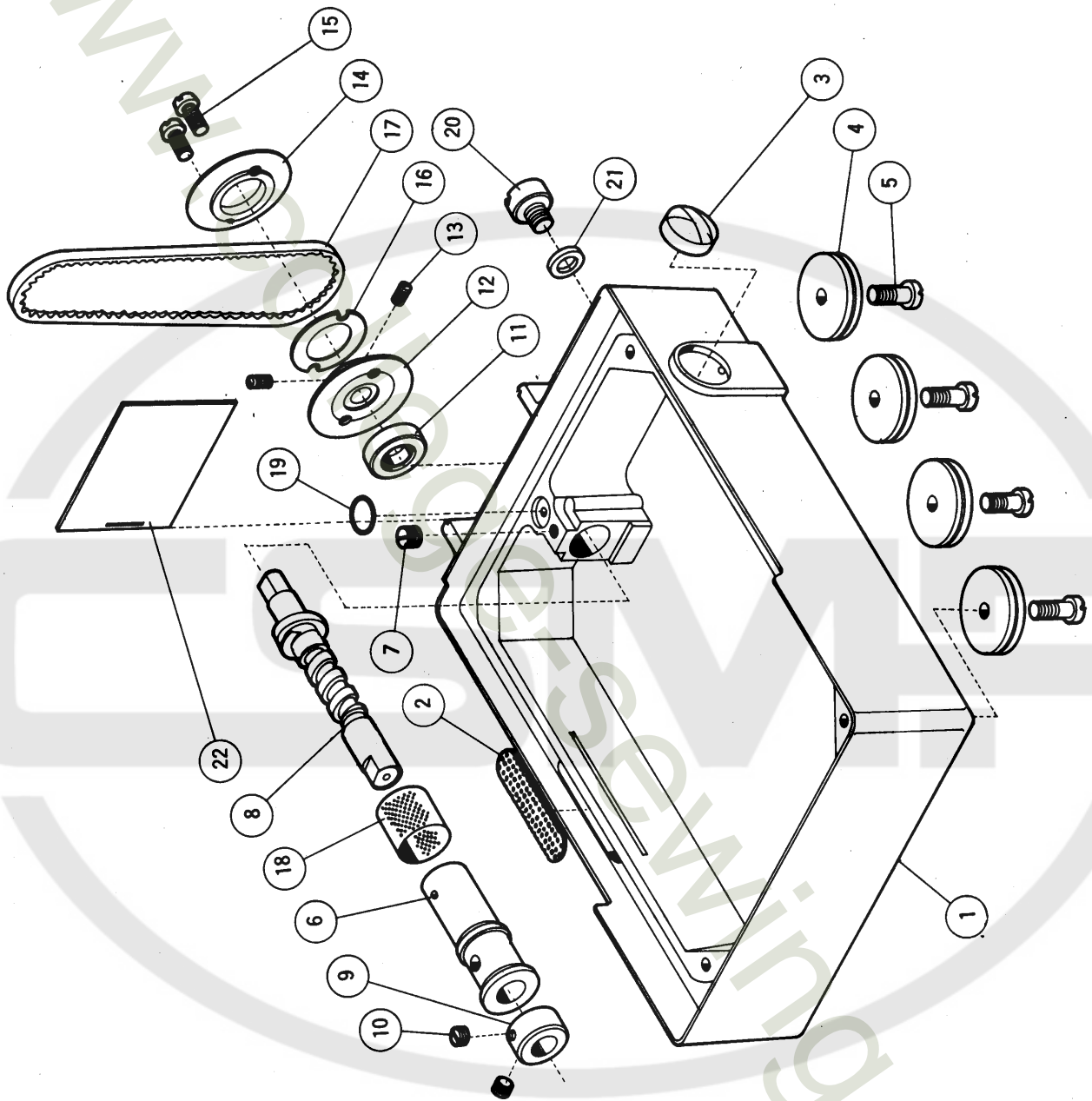

(1) PUMP LUBRICATING MECHANISM

給油機構 (1)

Ref. No.	Parts No.	Name	名称	Qt.
参照番号	部品番号			数量
			<u>202011A</u>	
			<u>202011A</u>	
1	202012A	Oil pan, complete with 200119 & 200120	オイルパン(組)200119, 200120トノ組	1
2	200119	" " filter	" 油濾金網	1
3	* 200120	" sight gauge	オイルゲージ	1
4	202013	Cushion rubber, complete with 202058	クッションゴム(組)202058トノ組	4
	* 202058	" " washer	" 座金	4
5	5134	" " screw	" 止ネジ	4
6	202015	Sleeve	スリーブ	1
7	5234 5000	" screw	" 止ネジ	1
8	202016	Spiral shaft	螺旋軸	1
9	201139	" " thrust collar	" スラストカラー	1
10	1457	" " " " screw	" " 止ネジ	2
11	202017	" " oil seal	オイルシール	1
12	202048	Oil pump pulley (right)	ポンププーリー(A)	1
13	1459	" " " " screw	" " 止ネジ	2
14	202049A	" " " (left)	" " (B)	1
15	5293	" " " " screw	" " 止ネジ	2
16	202066	" " " washer	" " 調節ワッシャー	1
17	202021	" " " belt	ポンプベルト	1
18	202022A	" filter	フィルター	1
19	202023	" pump outlet "O" ring	吐出口Oリング	1
20	5138B	" drain plug screw	排油穴蓋ネジ	1
21	202287A	" " " " washer	" 座金	1
22	202044A	" pan slide plate	オイルパン差板	1

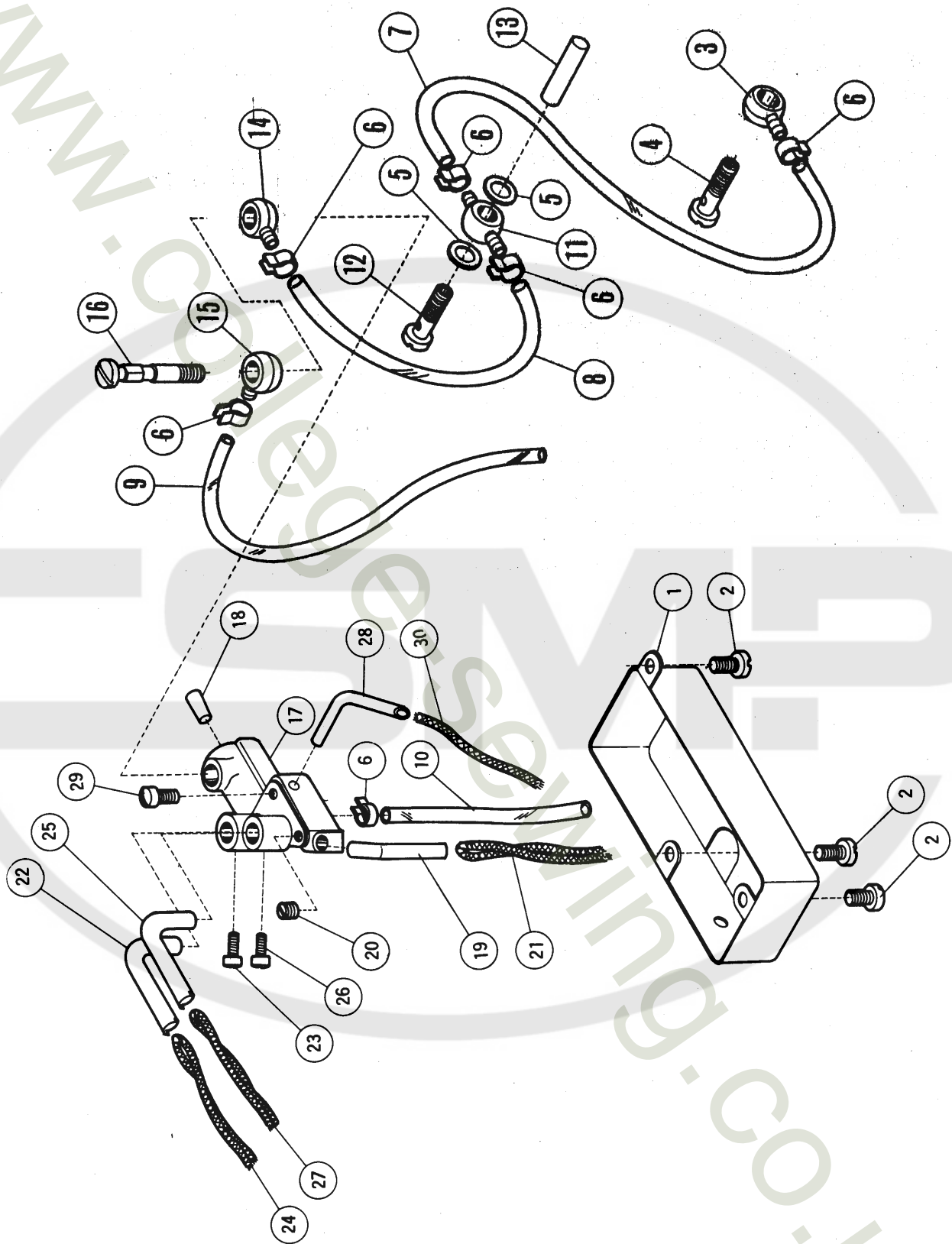

(2) PUMP LUBRICATING MECHANISM

給油機構 (2)

Ref. No.	Parts No.	Name	名称	Qt.
参照番号	部品番号			数量
1	202027	Machine frame bottom cover	底カバー	1
2	4009-1	" " " " screw	〃 止ネジ	3
3	200136	Oil vinyl tube joint	ベッド吐出管継手(雌)	1
4	200137	" " " " stud	〃 (雄)	1
5	200138	" " " washer	給油管継手パッキン	※ 2
6	202199	" " " clamp	ビニールパイプ抱キバネ	6
7	202028A	" " tube	上軸給油ビニールパイプ	1
8 205763 200134A-B	200134A-B	" " tube	油配分器用ビニールパイプ	1
9 202028A 200699	200699	" " tube	排油用ビニールパイプ	1
10 200140A 200698	200698	" " tube	油配分器排油用ビニールパイプ	1
11	202032	" " " joint	上軸給油管継手(雌)	1
12	200137	" " " " stud	〃 (雄)	1
13	202033	Needle bar drive crankshaft oil wick	上軸給油フェルト	1
14	200136	Oil vinyl tube joint	油配分器用ビニールパイプ継手(雌)	1
15	200136	" " " joint	排油用ビニールパイプ継手(雌)	1
16	202034	" distributor joint stud	油配分器継手(雄)	1
17	202035A	" distributor	油配分器	1
18	202903	" " plug	〃 油栓	1
19	200632	" tube	トリプルエキセン給油管	1
20	5113	" " screw	〃 〃 止ネジ	1
21	202176	Oil wick	〃 給油紐	1
22	202040	" tube	送りロックシャフト給油管	DC-MS 1
23	5064	" " screw	〃 〃 止ネジ	205, 220, 1
24	202176	" wick	〃 給油紐	230, 250用 1
25	202040	" tube	上メス台給油管	1
26 5064 5066	5066	" " screw	〃 〃 止ネジ	1
27	202176	" wick	〃 給油紐	1
28	202079	" tube	二重環ルーバー振り大ロッド給油管	1
29	2924	" " screw	〃 〃 〃 止ネジ	1
30	202175	" wick	〃 〃 給油紐	1

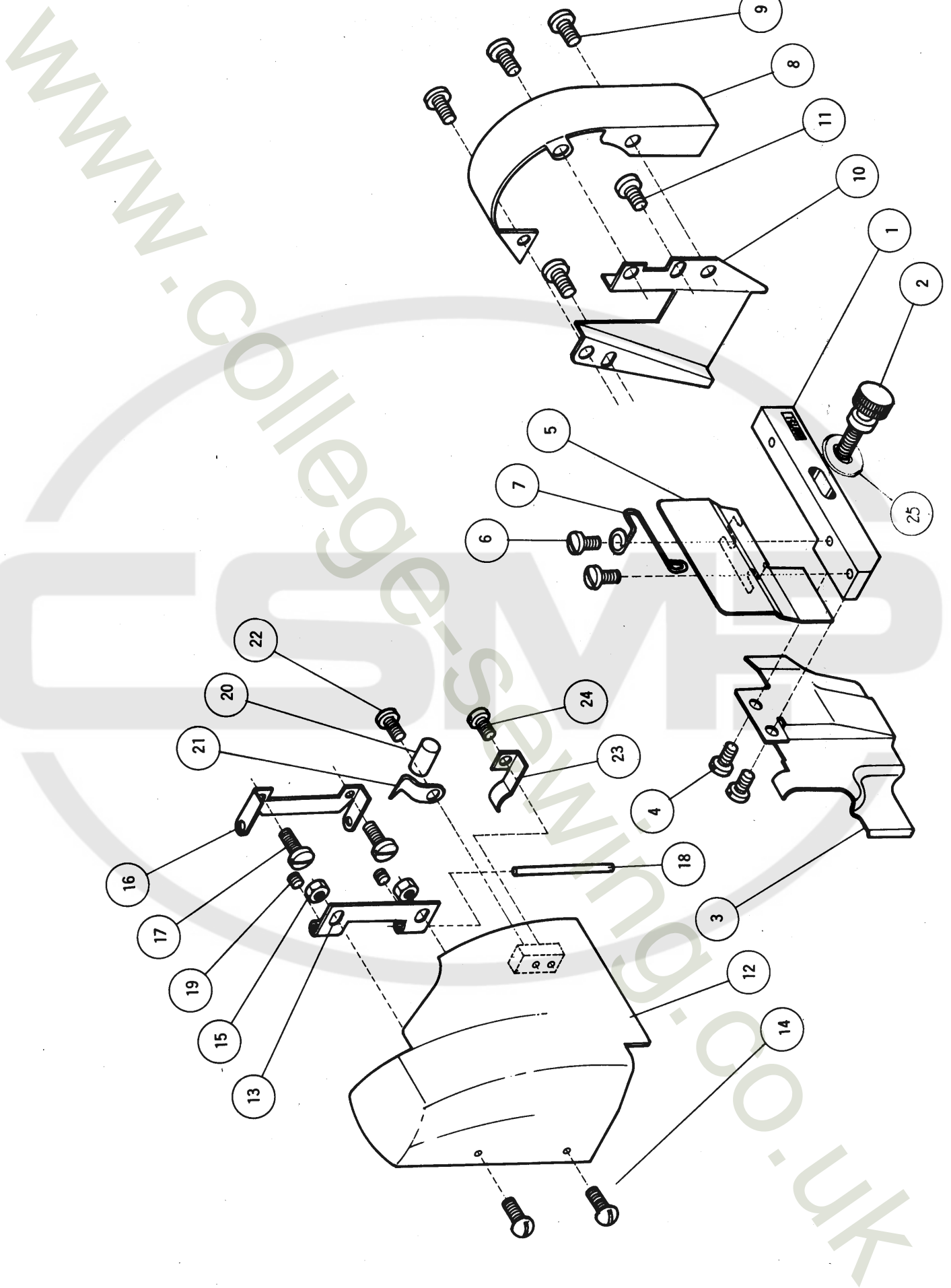

(1) MACHINE FRAME AND MISCELLANEOUS COVERS

カバ-・外装機構(1)

Ref. No.	Parts No.	Name	名称	Qt.
参照番号	部品番号			数量
1	200751	Front cover extension holder	角台	1
2	1281	" " " " screw	止ネジ	1
3	200752	Frame front oil shield	カバー	1
4	1216	" " " " screw	止ネジ	2
5	202087A	Front cover extension	切屑除ケ(メッキ)	1
5'	202185		色 (PW)	1
6	1202	" " " " screw	止ネジ	2
7	200187A	" " " " lock spring	前カバー止バネ	1
8	202008	Pulley cover	プーリーカバー	1
9	4009-1	" " " " screw	止ネジ	3
10	202050	Oil pump belt cover	ベルトカバー	1
11	5227 1106	" " " " screw	止ネジ	2
12	200670A	Needle bar cover	上カバー	1
13	200168	" " " " hinge (interior)	ヒンジ(A)	1
14	1326	" " " " " " screw	止ネジ	2
15	3091	" " " " " " nut	ナット	2
16	200671	" " " " (exterior)	(B)	1
17	2905	" " " " " " screw	止ネジ	2
18	200672	" " " " " " pin	ピン	1
19	5025 5028	" " " " " " screw	止ネジ	2
20	200697	" " " " " " rubber catch	当ゴム	1
21	200174	" " " " " " washer	座金	1
22	5328 5136	" " " " " " " " screw	止ネジ	1
23	200673	" " " " " " lock spring	止バネ	1
24	5328 5136	" " " " " " " " screw	止ネジ	1
25	137142		角台 止ネジ座金	1

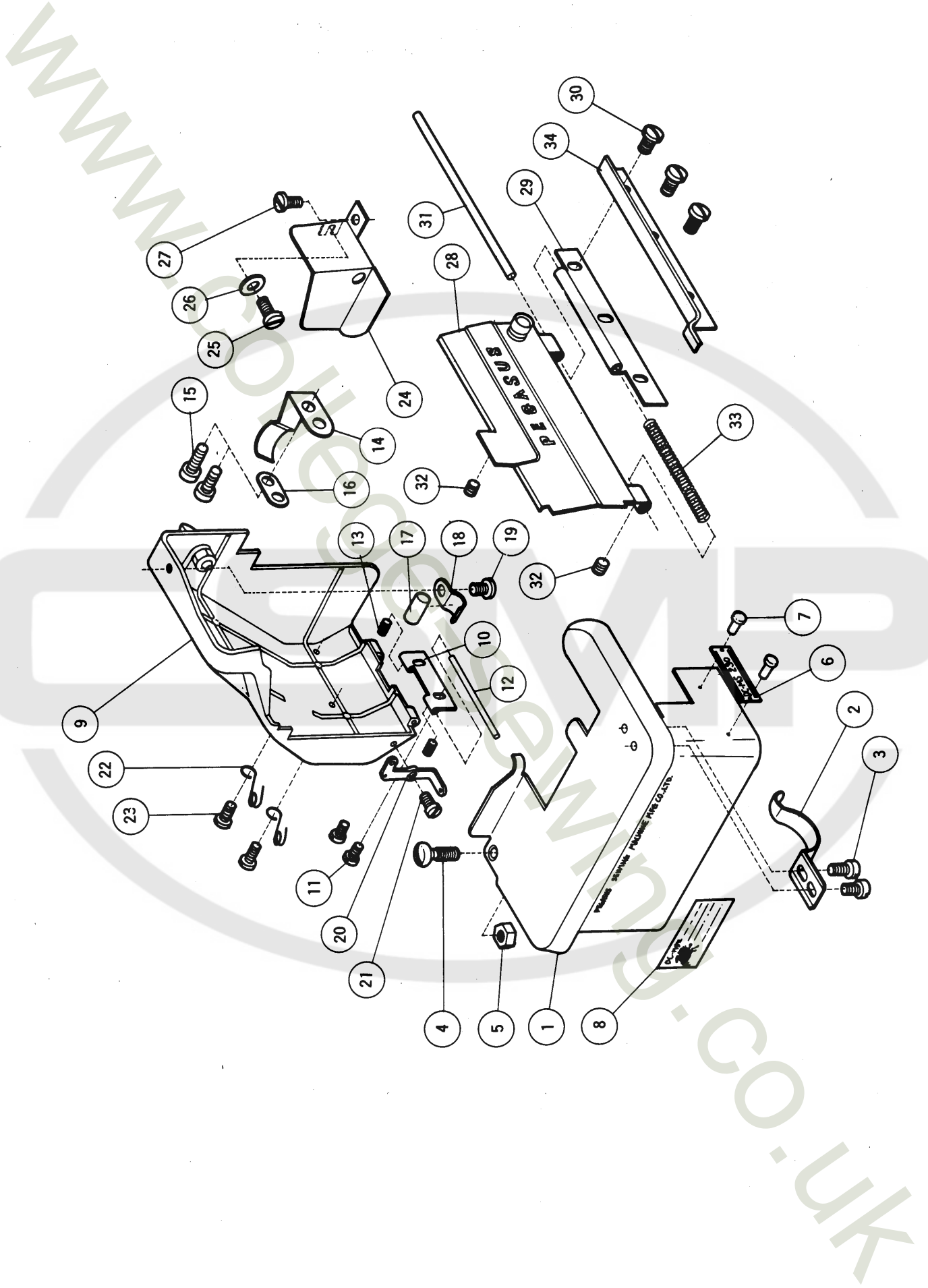

(2) MACHINE FRAME AND MISCELLANEOUS COVERS

カバ-・外装機構 (2)

Ref. No. 参照番号	Parts No. 部品番号	Name	名称	Qt. 数量
1	200743	Cloth plate, complete with 200744 & 200745	DC-MS 大カバー(組)200744, 200745ノ組	DC-MS 1
	*200744	" plate	205, 220, " (上)	205, 220, 1
	* 200745 200638	" " extension	230 & " (下)	230, 250用 1
2	137008	" " lock spring	250 only " 裏バネ	1
3	1234	" " " " screw	" " 止ネジ	2
4	2419	" " screw	" 止ネジ	DC-MS205, 220, 1
5	3144	" " " nut	" " ナット	230, 250用 1
6	202097 202073	Model plate (DC-MS230 only)	形式板 (DC-MS230用)	1
7	137011	" " pin	" 止ピン(白)	2
8	202082B	Patent plate	特許マーク	1
9	200640A	Frame cover (rear), complete with 200170 & 3044	後カバー(組)200170, 3044トノ組	1
	*200170	" " " knob	" ツマミ	1
	3044	" " " " nut	" " ナット	1
10	200168	" " " hinge	" ヒンジ	1
11	1216	" " " " screw	" " 止ネジ	2
12	200169	" " " " pin	" " ピン	1
13	5025	" " " " " screw	" " " 止ネジ	2
14	200172	" " " lock spring	" 止バネ	1
15	1175-2	" " " " " screw	" " 止ネジ	2
16	200162A	" " " " " " washer	" " " 座金	1
17	200173 200097	" " " " rubber catch	" 当ゴム	1
18	200174	" " " " " washer	" " 座金	1
19	2905	" " " " " " screw	" " " 止ネジ	1
20	200783A	Thread guide	糸道(A)	1
21	5012	" " " screw	" " 止ネジ	1
22	193174	" eyelet	" (B)	2
23	1326	" " screw	" " 止ネジ	2
24	200641	Needle bar connection cover	大ロッドカバー	1
25	4009-1	" " " " " screw (rear)	" 止ネジ(後)	1
26	137142	" " " " " " washer	" " " 座金	1
27	1175-2	" " " " " (front)	" " (前)	1
28	200961 200746	Front cover, complete with 200747, 200748x2 & 200186	前カバー(組)200747, 200748×2, 200186ノ組	1
	200862 *200747	" cover	" 本体	1
	*200748	" " hinge(interior)	" ヒンジ(上)	2
	*200186	" " knob	" ツマミ	1
29	200184	" " hinge (exterior)	" ヒンジ(下)	1
30	1216	" " " " " screw	" " " 止ネジ	3
31	200749	" " " " pin	" " ピン	1
32	5025	" " " " " screw	" " " 止ネジ	2
33	200750	" " " " " spring	" " " バネ	1
34	200260	Arm-bed & oil pan interstice cover	オイルパン隙間カバー	1
	149010	"	大カバー用銘板(ベガサス用)	1
	202188	"	" (W-G用)	1
	137911	"	" (PFAFF用)	1

◦ DC-MS 230 ◦

1

◦ DC MS 220 ◦

2

◦ DC-MS 205 ◦

3

◦ DC-MS 250 ◦

4

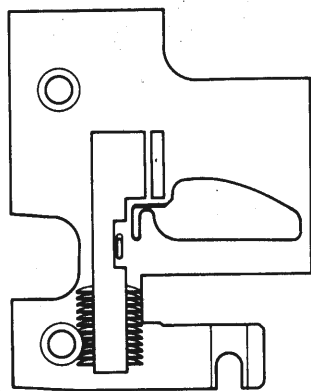

11

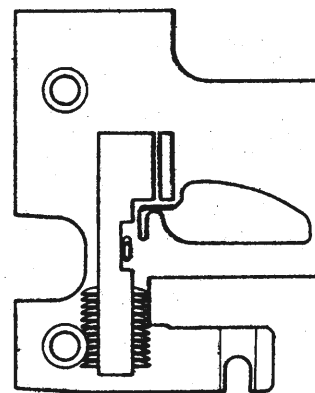

13

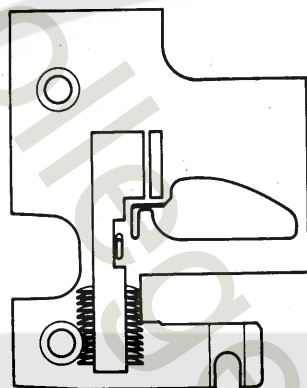

12

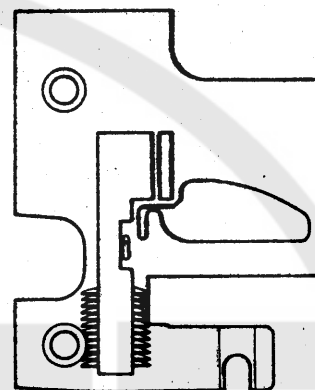

14

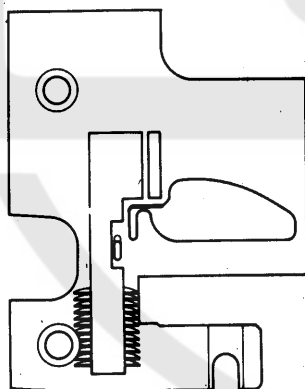

9

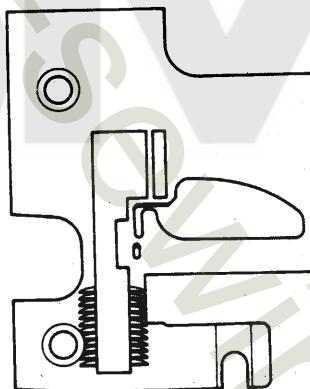

15

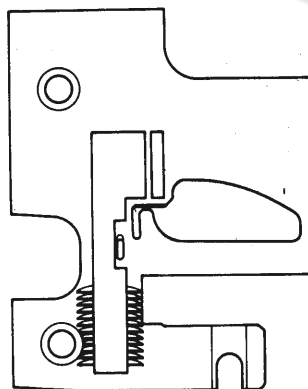

10

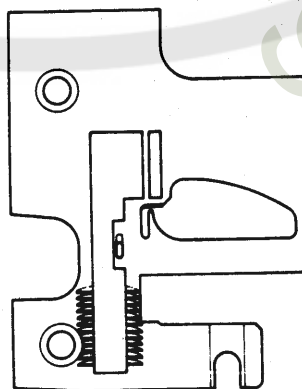

16

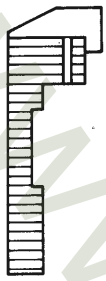

23

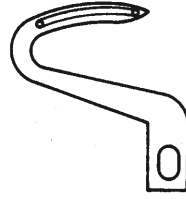

34

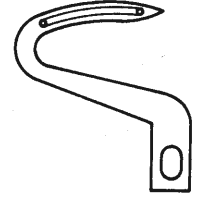

35



26

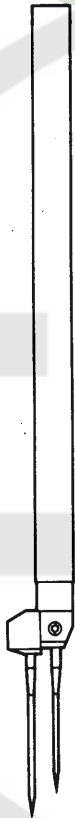

27

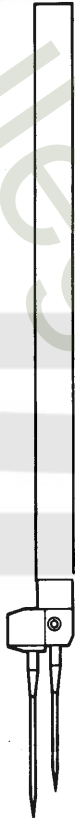

28



29

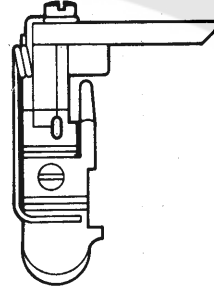

36

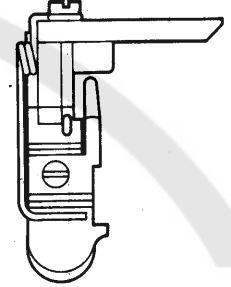

37

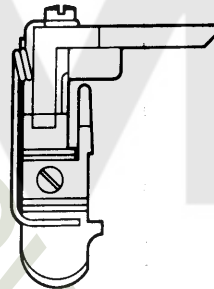

38

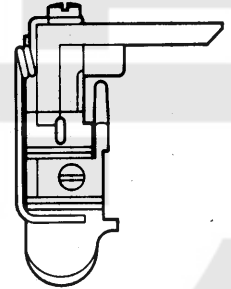

39

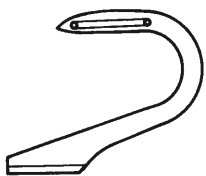

30

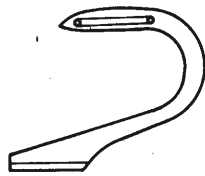

31

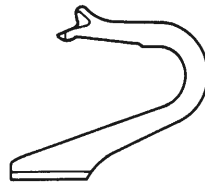

32

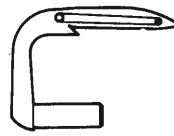

33



40



41

LIST OF ORGANIZATION PARTS

ゲージ・パーツ表

ゲージ・パーツ表ご利用に際して

- このゲージ・パーツ表には、機種、ゲージ（針巾×縫巾）、オーバーロック側に使用される糸の種類、本数別に各ゲージ・パーツを記載しています。
太字で表示している機種はDC-MSシリーズの標準機種であります。（注）縫巾とはオーバーロック縫巾です。
- このゲージ・パーツ表に記載されている押エ（組）は、押エ本体ピン200796、押エ200734、押エ爪200735 A、押エ爪止ネジ1231、押エ補助バネ200729 A、押エ補助バネ止ネジ1229、（使用数各1）の全機種共通パーツと、
DC-MS230, (200731) には押エ本体200733が組合せられています。
DC-MS220, (200730) 〃 200732 〃
DC-MS205, (202120) 〃 202121 〃
DC-MS250, (202086) 〃 202101 〃
- 針棒（組）は針棒141122、針止ネジ5292（使用数2）の全機種共通パーツと、
DC-MS230, (700711) には針株700713が組合せられています。
DC-MS220, (200710) 〃 200712 〃
DC-MS205, (202119) 〃 202118 〃
DC-MS250, (202100) 〃 202084 〃

Model	Gauge(Needle gauge × Seam width)	Threads used for overlock stitch.	Page	Ref. No.	Model plate	Page	Ref. No.	Needle plate	Page	Ref. No.	Feed dog (Plain feed)	Page	Ref. No.	Main feed dog	Page	Ref. No.	Differential feed dog
形式	ゲージ(mm) (針巾×縫巾)	オーバーロック側 使用糸	頁	参照 番号	形式板	頁	参照 番号	針板	頁	参照 番号	送り歯 (1枚送り)	頁	参照 番号	主送り歯	頁	参照 番号	差動 送り歯
DC-MS230	3mm×3mm	カタン糸又ハウリー糸 Cotton or Woolly yarn	26	1	202097 202073	26	9	200715A	27	23	200723A						
〃	〃	綿糸 Soft(Spool)	〃	〃	〃	〃	10	200949	〃	〃	〃						
〃	〃	カタン糸又ハウリー糸 (2本糸) Cotton or Woolly yarn (2-thread machine)	〃	〃	〃	〃	11	200953	〃	〃	〃						
DC-MS220	2mm×3mm	カタン糸又ハウリー糸 Cotton or Woolly yarn	26	2	202096 202072	26	12	200714A	27	23	200723A						
〃	〃	綿糸 Soft(Spool)	〃	〃	〃	〃	13	200948	〃	〃	〃						
〃	〃	カタン糸又ハウリー糸 (2本糸) Cotton or Woolly yarn (2-thread machine)	〃	〃	〃	〃	14	200952	〃	〃	〃						
DC-MS205	0.5mm×3mm	綿糸 Soft(Spool)	26	3	202098 202095	26	15	202123	27	23	200723A						
DC-MS250	5mm×3mm	綿糸 Soft(Spool)	26	4	202099 202091	26	16	202085	27	23	200723A						

IN ORDERING ORGANIZATION PARTS

This List contains the Organization Parts for each machine model and gauge (needle gauge x overlock seam width), and enables you to know necessary parts for repairs or converting your machine to another model or gauge. And the models in BLOCK type are the standard machines of DC-MS series.

All presser feet (complete) shown on this List consist of a PRESSER FOOT BODY with each needle gauge (List I) and the common parts to all models of DC-MS series (List II).

— List I —

PRESSER FOOT BODY PRESSER FOOT (COMPLETE)
Parts No.200733 . . for Parts No.200731 of model DC-MS230 .

PRESSER FOOT BODY PRESSER FOOT (COMPLETE)
Parts No.202121 . . for No.202120 of model DC-MS205
No.202101 . . for No.202086 of model DC-MS250 .

No.200732 . . for No.200730 of model DC-MS220 .

— List II —

THE COMMON PARTS TO ALL MODELS

Parts No.200796 (Presser foot body pin)
No.200734 (Presser foot body bracket)
No.200735A (Presser foot chaining-off finger)

Parts No.1231 (Presser foot chaining-off finger screw)
No.200729A (Presser foot spring)
No.1229 (Presser foot spring screw)

All needle bars (complete) in this List consist of NEEDLE BAR (No.141122), 2 pieces NEEDLE CLAMP SCREWS (No.5292) and the following NEEDLE CLAMP with each needle gauge.

NEEDLE CLAMP

Parts No.200713 . . for No.200711 of model DC-MS230
No.200712 . . for No.200710 of model DC-MS220 .

Parts No.202118 . . for No.202119 of model DC-MS205
No.202084 . . for No.202100 of model DC-MS250

Page	Ref. No.	Needle bar (complete)	Page	Ref. No.	Right looper	Page	Ref. No.	Left looper	Page	Ref. No.	Double chain-stitch looper	Page	Ref. No.	Presser foot (complete)	Page	Ref. No.	Upper knife	Page	Ref. No.	Lower knife
頁	参照番号	針棒(組)	頁	参照番号	大ルーバー	頁	参照番号	小ルーバー	頁	参照番号	二重環ルーバー	頁	参照番号	押工(組)	頁	参照番号	上メス	頁	参照番号	下メス
27	26	200711	27	30	137301	27	33	137302	27	34	200785	27	36	200731	27	40	138559	27	41	137562
〃	〃	〃	〃	〃	〃	〃	〃	〃	〃	〃	〃	〃	〃	〃	〃	〃	〃	〃	〃	〃
〃	〃	〃	27	32	139301	〃	〃	〃	〃	〃	〃	〃	〃	〃	〃	〃	〃	〃	〃	〃
27	27	200710	27	30	137301	27	33	137302	27	34	200785	27	37	200730	27	40	138559	27	41	137562
〃	〃	〃	〃	〃	〃	〃	〃	〃	〃	〃	〃	〃	〃	〃	〃	〃	〃	〃	〃	〃
〃	〃	〃	27	32	139301	〃	〃	〃	〃	〃	〃	〃	〃	〃	〃	〃	〃	〃	〃	〃
27	28	202119	27	30	137301	27	33	137302	27	35	202133	27	38	202120	27	40	138559	27	41	137562
27	29	202100	27	31	200340	27	33	137302	27	34	200785	27	39	202086	27	40	138559	27	41	137562

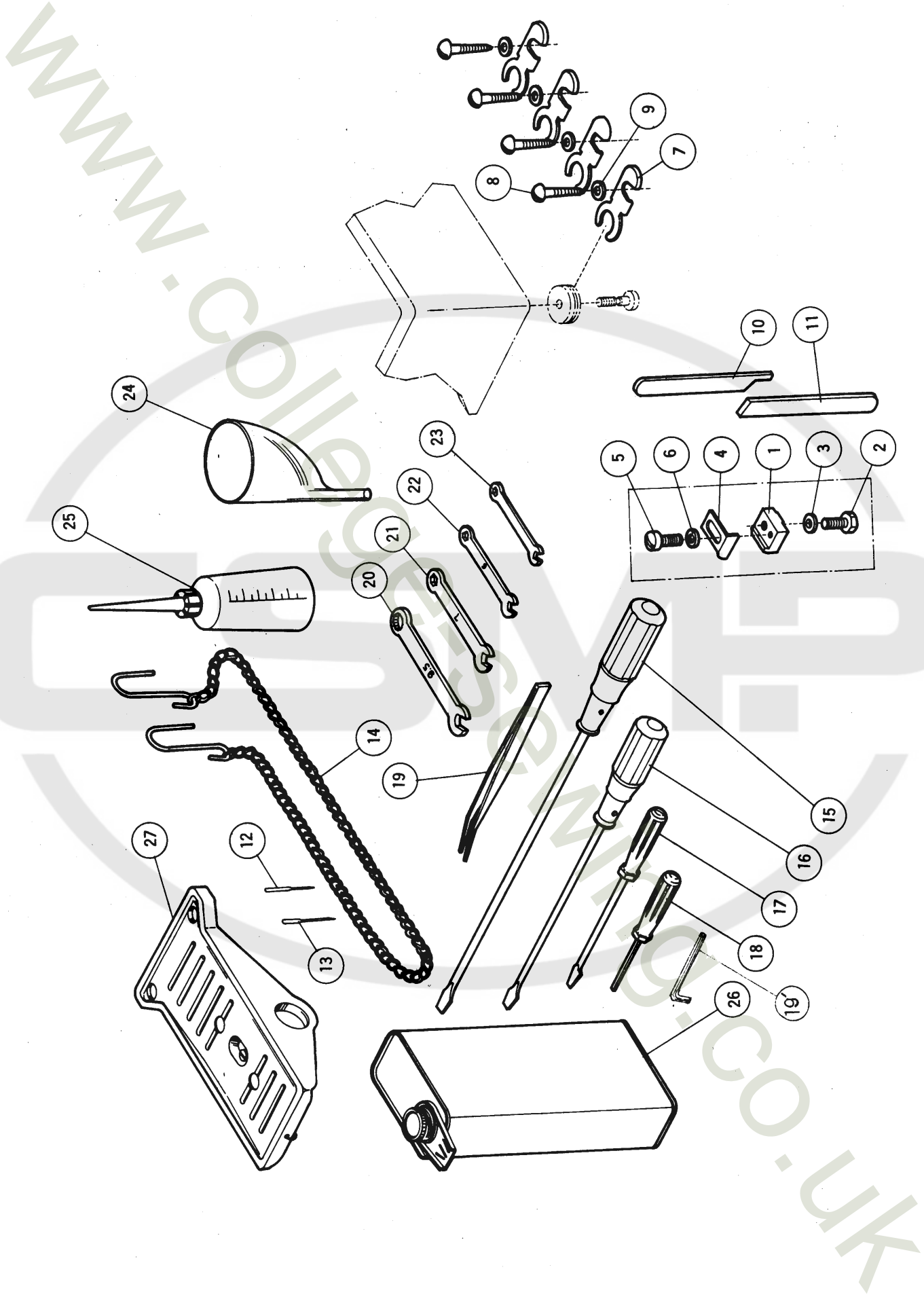

ACCESSORIES

付 属 品

Ref. No. 参照番号	Parts No. 部品番号	Name	名 称	Qt. 数量
	200472	Cloth guide, complete with 138905, 2193, 137142, 200668, 1202 & 137906	定規台(組)138905, 2193, 137142, 200668, 1202, 137906ノ組	1
1	138905	" guide bracket	"	1
2	2193	" " screw	" 止ネジ	1
3	137142	" " " washer	" " 座金	1
4	200668	" guide	定規	1
5	1202	" " screw	" 止ネジ	1
6	137906	" " " washer	" " 座金	1
7	202014A	Oil pan set hook	オイルパン足金	4
8	4905 3018	" " " " wood screw	" 据付用木ネジ	4
9	137142	" " " " " " " washer	" " 座金	4
10	138559	Upper knife (for exports only)	上メス(貿易用)	1
11	137562	Lower knife (" " ")	下メス(")	1
12	DC×1	Needle	針	10
13	DM×13	Needle	"	10
14	126	Treadle chain	鎖	1
15	127	Screw driver (large)	ドライバー(大)	1
16	128	" " (medium)	" (中)	1
17	129	" " (small)	" (小)	1
18	179	Allen wrench	ソケットスクリュー用ドライバー	1
19	131	Tweezers	ピンセット	1
19	182		ピンレンチ(3.2mm用)	1
20	286 130A-9.5	Wrench (9.5mm)	スパナ 9.5mm	1
21	284 130A-7	" (7.0mm)	" 7 mm	1
22	283 130A-6	" (6.0mm)	" 6 mm	1
23	281 130A-4	" (4.0mm)	" 4 mm	1
24	135A	Oil funnel	ジョウゴ	1
25	132	Oiler	油差シ	1
26	133	Oil container (500cc)	油缶(500cc入)	1
27	245 191	Treadle, complete	靴(組)	1
	290		糸立(組)(5本立用) (1979年11月より品番が371に変更されます。)	1

NUMERICAL INDEX OF PARTS

部 品 番 号 索 引

Parts No.	Page	Ref. No.	Parts No.	Page	Ref. No.	Parts No.	Page	Ref. No.	Parts No.	Page	Ref. No.	Parts No.	Page	Ref. No.
部品番号	頁	参照番号	部品番号	頁	参照番号	部品番号	頁	参照番号	部品番号	頁	参照番号	部品番号	頁	参照番号
245 126	5	27	1234	23	3	3044	7	29	101111	5	45	139301	29	32
127	31	27	1281	21	2	3044	11	38	101111	7	35	140402	13	14
128	31	14	1326	23	23	3044	15	10	101111	7	42	141105A	5	49
129	31	15	1326	21	14	3044	15	19	101111	11	35	141122	5	
286 130A-9.5 31	17	16	1435	11	30	3044	23		101113	7	33	141122	28	
284 130A-7 31	20	17	1457	5	11	3056	7	32	101113	7	40	141122	29	
283 130A-6 31	21	21	1457	5	13	3056	7	39	137142	31	3	167072	11	36
281 130A-4 31	22	22	1457	5	36	3056	11	33	137008	23	2	167077	11	34
	23	23	1457	11	25	3091	9	28	137011	23	7	192070	5	26
						3091	21	15	137101	5	29	193174	23	22
131	31	19	1457	17	10	3092	9	29	137104	7	30	200033	5	1
132	31	25	1457-1	9	47	3144	23	5	137106	7	38	200034	5	
133	31	26	1457-1	11	17	4009-1	3	21	137114	7	41	200037	5	10
135A	31	24				4009-1	19	2	137115	7	34			
179	31	18	1458	15	8	4009-1	23	25	137121	7	5			
1132	15	33	1459	17	13	4009-1	21	9	137123	5	35			
1156	9	11	1732	5	38	5001	13	9	137130	5	3			
1156	13	11	1817-2A	5	46	5002	11	2	137130	7	3			
1170	9	3	1817-2A	7	36	5002	11	9	137140	15	1			
1170-3	5	21	1817-2A	7	43	5002	13	2	137141	15	4			
			1936A	3		5003	13	3	137142	7	37			
		27	2022	5	15	5010	5	4	137142	7	44	200119	17	2
1174	9	20	2022	9	8	5010	7	4	137142	13	8	200120	17	3
1174	9	23	2022	9	16	5012	23	21	137142	15	13	200131A	19	8
1174	15	22	2022-3	3	14	4905 5019	23	8	137142	23	26	200136	19	3
			2022-3	7	21	5025 5023	21	19	137142	27	9	200136	19	14
1175-2	13	22	2022-3	13	13	5025	21	13	137143	15	6	200136	19	15
1175-2	23	15	2022-4	5	8	5025	21	32	137145A	15	15	200137	19	4
1175-2	23	27	2022-4	7	6	5051	3	24	137146	15	14	200137	19	12
1175-2	25	19	2022-4	7	11	5052	3	25	137147	15	20	200138	19	5
			2022-4	9	13	5053	7	23	137301	7	12	200162A	23	16
1175-3	11	28	2133	15	18	5053	13	20	137301	29	30	200168	23	10
1186	5	25	2133-1	15	27	5056	15	7	137302	7	22	200168	21	13
1186	11	6	2193	31	2	5058	3	9	137302	29	33	200169	23	12
1186	13	6	2213	15	3	5234 5060	17	7	137307A	7	14	200170	23	
1196	5	23	2213	15	16	5061	5	39	137409	7	10	200172	23	14
1196	7	13	2213-1	5	2	5064	9	31	137409	13	12	200174	23	18
1196	7	25	2213-1	7	2	5064	9	39	137417	13	15	200174	21	21
5317 1196	11	21	2213-1	9	2	5064	19	23	137419	13	7	200184	23	29
1196	21	11	2237	11	19	5064	19	26	137442	13	17	200186	23	
			2237	13	18	5065	15	41	137442-1	13	19	200187A	21	7
1202	5	41	2285	15	17	5069	15	45	137552	15	2	200204	11	37
1202	9	33	2308	15	12	5070	15	42	137552	15	26	200211	3	6
1202	9	35				5113	19	20	137553	15	38	200260	23	34
1202	9	45	2366-2	15	23	5132	3	3	137554	15	36	200265	5	7
1202	21	6	2368	3	16	5133	3	4	137558	15	35			
1202	31	5	2370	15	9	5134	17	5	137560	15	34			
1216	5	30	2371	15	5	5325 5138	21	22	137562	15	43			
1216	7	31	2419	23	4	5328 5136	21	24	137562	29	41			
1216	9	6	2905	23	19				137562	31	11			
1216	23	11												
1216	23	30	2905	21	17	5138B	17	20	137563	15	44			
1216	21	4	2913-1	3	10				137906	31	6	200322	13	10
1222	5	19	2918	11	3	5224	15	31	137950	3		200340	29	31
1222	15	37				5229	28		138555A	15	29	200389	3	12
1229	28		2922	7	16	5229	29		138555-1	15	30	200389	5	9
1229	29		2924	19	29	5259	15	39	138556	15	32	200396	9	22
1231	28					5292	5	32	138559	15	28	200398	9	26
1231	29		3018	9	25	5292	9	37	138559	29	40	200400	9	24
1234	5	6	3018	15	24	5293	17	15	138559	31	10	200401	9	21
1234	9	42	3044	5	48	9070-2	5	28	138905	31	1	200472	31	

Parts No.	Page	Ref. No.	Parts No.	Page	Ref. No.	Parts No.	Page	Ref. No.	Parts No.	Page	Ref. No.	Parts No.	Page	Ref. No.
部品番号	頁	参照番号	部品番号	頁	参照番号	部品番号	頁	参照番号	部品番号	頁	参照番号	部品番号	頁	参照番号
			200725A	15	25	200795A	9	43	202079	19	28	202176	7	19
			200726A	15	40	200796	28		202081	9	4	202176	9	17
200503	13	1	200729A	28		200796	29		202082B	23	8	202176	11	12
200531	5	22	200729A	29		200798B	9	41	202083A	9	5	202176	11	23
200534	5	5	200730	28		200799B	9	36	202084	28		202176	11	31
200605	3		200730	29		200947	7	15	202084	29		202176	13	24
200607	3	11	200730	29	37	200948	28	13	202085	28	16	202176	19	21
200618	7	1	200730	29	37	200948	28	10	202086	28		202176	19	24
200620	7	8	200731	15	11	200950	28	20	202086	29		202176	19	27
200621A	7	26	200731	28		200951	28	18	202086	29				
200622A	7	27	200731	29					202086	29	39			
			200731	29	36	200952	28	14	202087A	17	21	202177	5	18
200623A	7	28	200732	28		200953	28	11	202087A	21	5	202179	7	20
200624	7	17	200732	29		201035A	5	42	202088	13	16			
200625	7	18	200733	28		201037	5	43	202090	28	3			
200627	13	23	200733	29		201039	5	44	202091	28	4	202199	19	6
200628	13		200733	29		201139	17	9	202100	28		202278	5	47
3044 200629	13		200734	28		202001	3		202100	29		202757A	11	22
200631	15	21	200734	29		202006	3	15	202100	29	29	202903	19	18
200632	11	24	200734	29		202007	3	23	202101	28				
200632	19	19	200735	29		202008	21	8	202101	29		DC×1	5	33
200633	3	17	200737	11	5	202010	5	12				DC×1	31	12
			200737	13	5	202012A	17	1				DM×13	5	34
200640A	23	9	200741	11	15	202013	17	4				DM×13	31	13
200641	23	24	200742	9	18	202014A	31	7				202045	3	5
200652	5	14	200742	11	13	202015	17	6				1920	5	27
200653	5	16	200742	11	32	202016	17	8				200821	5,7	4,5'
200654	5	17	200743	21	1	202017	17	11				202184	5	50
200655	5	20	200744	21		202019	3	26				2922	5	51
200664	3	22	200745	23		202021	17	17				200769	11	1
200668	31	4	200746	23	28	202022A	17	18				3044	13	
200670A	21	12	200747	23		202023	17	19				205763	19	8
200671	21	16				202024	3	18				202028A	19	9
			200748	21	23	202025	3	19				200140A	19	10
200672	21	18	200749	21	23	202026	3	20				202185	21	5'
200673	21	23	200750	21	23	202027	19	1	202118	28		137142	21	25
200697	21	17	200751	23	21	202028A	19	7	202118	29		200638	23	
200697	21	20	200752	23	21	202032	19	11	202119	28		202097	23	6
200699	19	10	200756	9	7	202033	19	13	202119	29		200173	23	17
200699	19	9	200757	9	9	202034	19	16	202119	29	28	200961	23	28
200703	3	8	200758	9	10	202035A	19	17	202120	28		200862	23	
200707	3	13	200759	9	12				202120	29		149010	23	
200709	5	24	200760	9	14	202040	19	25	202120	29	38	202188	23	
200710	28		200761	9	15	202044A	17	22	202121	28		137911	23	
			200767	9	27	202046	3	2	202121	29		202097	28	
200710	29	27	200769	11	1	202047	11	4	202123	28	15	202096	28	
200711	5	31	200770	11	7	202048	17	12				202098	28	
200711	28		200771	11	8	202049A	17	14				137142	31	
200711	29		200772	11	10	202050	21	10				290	31	
200711	29	26	200773	11	11	202051	3	5				182	31	19'
200712	28		200773	11	14	202058	17							
200712	29		200775	11	16	202066	17	16						
200713	5		200776	11	18	202070	3	1						
200713	28					202071	3		202133	29	35			
			200777	11	20	202072	28	2						
200713	29		200779	11	26	202073	23	6	202135	7	7			
200714A	28	12	200780	11	27	202074	28	1	202136	9	34			
200715A	5	37	200781	11	29	202074	3	7	202137	9	40			
200715A	28	9	200782	9	30	202075A	3		202138	9	19			
200716	5	40	200783A	23	20	202076	9		202175	19	30			
200717	7	24	200785	9	32	202077A	9	1	202176	7	9			
200718	7	45	200785	29	34									
200719	9	46	200787A	9	38									
200723A	13	21	200793	9	44									
200723A	28	23												

www.collegesewing.co.uk



www.collegesewing.co.uk



www.collegesewing.co.uk



CSMA