

# MITSUBISHI

## 三菱工業用ミシン部品カタログ

## Industrial Sewing Machine Parts Catalog

Model      LT2-2220-L0B  
 LT2-2220-M0B  
 LT2-2220-B0B  
 LT2-2230-L1T  
 LT2-2230-M1TW  
 LT2-2230-B1T

目次	INDEX	Page
① 本 体 部 分	Body & it's accessories .....	2
② 上糸調節器部分(国内用)(I)	Thread tension regulator mechanism (Domestic only) (I) .....	4
③ 上糸調節器部分(輸出用)(II)	Thread tension regulator mechanism (Export only) (II) .....	6
④ 上軸・押え・ひざ上げ機構	Upper shaft & presser foot mechanism .....	8
⑤ 天秤・針棒揺動機構	Thread take-up lever & needle bar rock motion mechanism .....	10
⑥ 縫目加減機構	Stitch regulator mechanism .....	12
⑦ 下軸・送り機構	Lower shaft & feed rock shaft mechanism .....	14
⑧ カマ台機構	Hook saddle mechanism .....	16
⑨ 糸切り機構(I)	Knife mechanism (I) .....	18
⑩ 糸切り機構(II)	Knife mechanism (II) .....	20
⑪ タッチバックおよび検出器機構	Touch back, compensation stitching & detector mechanism .....	22
⑫ ワイパー機構	Wiper mechanism .....	24
⑬ 給油機構	Oil lubrication mechanism .....	26
⑭ 付 属 品	Accessories .....	26
⑮ ゲージ部品表(I) LT2-2220	Gauge parts list (I) .....	30
⑯ ゲージ部品表(II) LT2-2230	Gauge parts list (II) .....	32

① 本体部分  
 BODY AND IT'S ACCESSORIES

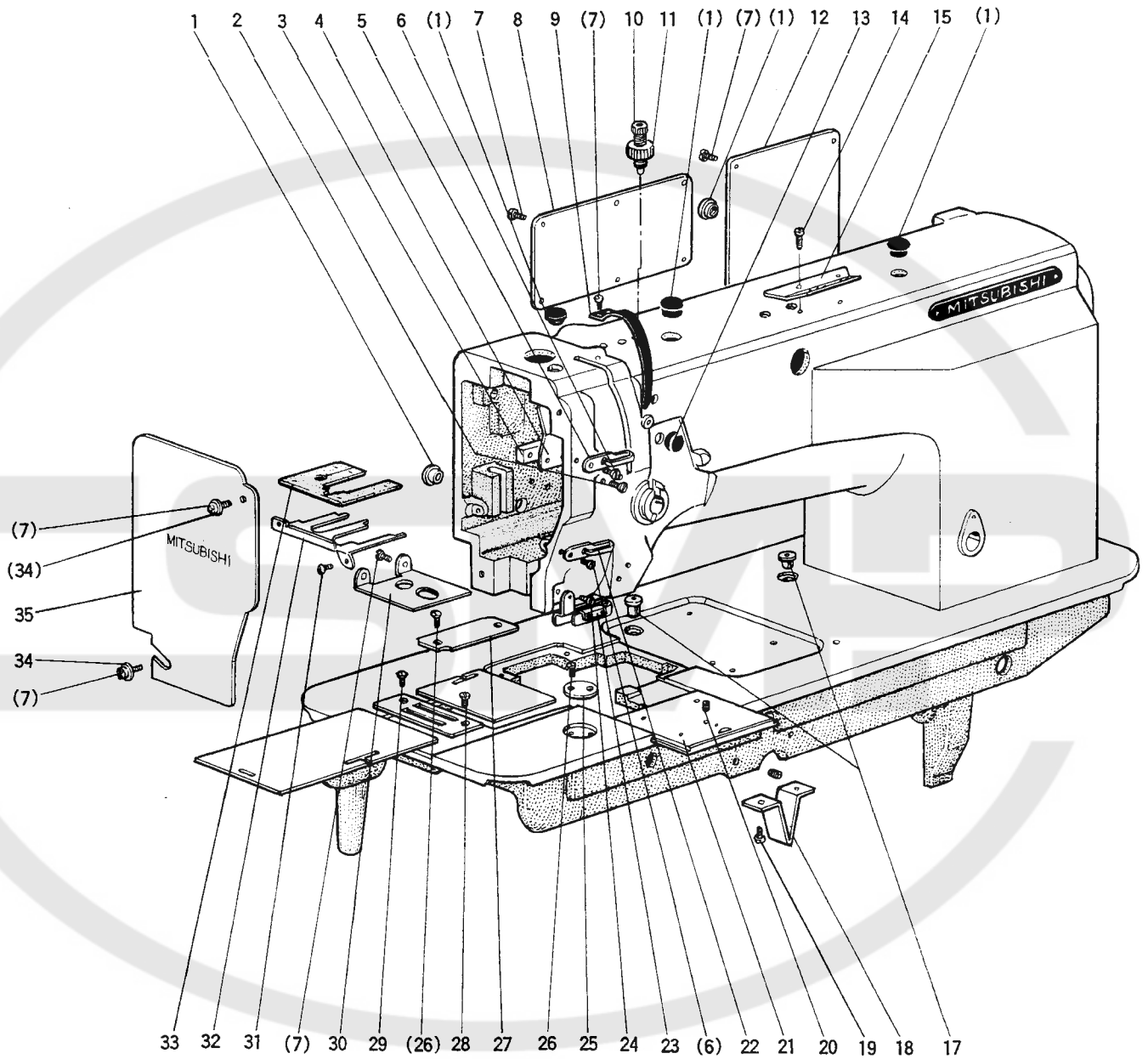

# ① 本体部分 BODY AND IT'S ACCESSORIES

Fig. No.	部品コード Part No.	部 品 名	Description	使用個数 Amt. Req.					
				LT2-2220			LT2-2230		
				LOB	MOB	BOB	LT	MITW	BIT
1	M9 1304 080	ゴム セン	φ13..... Rubber plug φ13.....	5	5	5	5	5	5
2	M9 1201 011	丸皿 ネジ	$3/16(28) \times 11$ ..... Screw $3/16(28) \times 11$ .....	2	2	2	2	2	2
3	MN 10A0 476	油ベ	Spacer.....	1	1	1	1	1	1
4	MN 10A0 131	油受	Oil guard plate.....	1	1	1	1	1	1
5	MN 70A0 181	糸案内	Thread guide.....	1	1	1	1	1	1
6	M9 0904 011	丸皿 ネジ	$9/64(40) \times 6.5$ ..... Screw $9/64(40) \times 6.5$ .....	2	2	2	2	2	2
7	M9 1106 004	丸皿 ネジ	$11/64(40) \times 8$ ..... Screw $11/64(40) \times 8$ .....	15	15	15	11	11	11
8	MN 70A0 880	横蓋	Side cover.....	1	1	1	1	1	1
9	MN 70A0 584	天ビンカバー	Thread take-up cover.....	1	1	1	1	1	1
10	M9 7002 035	ツマミ ネジ	M10×39..... Thumb screw M10×39.....	1	1	1	1	1	1
11	M9 2512 045	トクシュナット	M10..... Special nut M10.....	1	1	1	1	1	1
12	MN 70A0 237	裏蓋	Rear cover.....	1	1	1	1	1	1
13	M9 1305 080	ゴム セン	φ13..... Rubber plug φ13.....	1	1	1	1	1	1
14	M9 1116 002	平ネジ	$11/64(40) \times 8$ ..... Screw $11/64(40) \times 8$ .....	2	2	2	2	2	2
15	MN 40A0 180	糸案内	Thread guide.....	1	1	1	1	1	1
17	MN 10A4 742	蓋 (オイルカップ)	Cap.....	2	2	2	2	2	2
18	MN 50A0 426	支エ	Supportor.....	1	1	1	1	1	1
19	M9 1601 003	丸平ネジ	$1/4(24) \times 9$ ..... Screw $1/4(24) \times 9$ .....	2	2	2	2	2	2
20	M9 1301 001	止メネジ	$13/64(32) \times 4.8$ ..... Screw $13/64(32) \times 4.8$ .....	1	1	1	1	1	1
21	MN 70A0 472	スベリ板	Slide plate (complete).....	1	1	1	1	1	1
22	MN 70A1 181	糸案内	Thread guide.....	1	1	1	1	1	1
23	MN 70E0 181	糸案内	Thread guide (complete).....	1	1	1	1	1	1
24	M9 0920 002	糸平ネジ	$9/64(40) \times 6.5$ ..... Screw $9/64(40) \times 6.5$ .....	1	1	1	1	1	1
25	MN 50A5 742	蓋	Cover.....				1	1	1
26	M9 0916 011	皿ネジ	$9/64(40) \times 6$ ..... Screw $9/64(40) \times 6$ .....				4	4	4
27	MN 72A0 742	皿蓋	Cover.....				1	1	1
28	M9 1106 011	丸皿ネジ	$11/64(40) \times 8$ ..... Screw $11/64(40) \times 8$ .....	1	1	1	1	1	1
29	M9 0952 003	丸平ネジ	$9/64(36) \times 6.5$ ..... Screw $9/64(36) \times 6.5$ .....	1	1	1	1	1	1
30	MN 70A0 339	カバー	Cover.....	1	1	1	1	1	1
31	M9 0910 003	丸平ネジ	$9/64(40) \times 7$ ..... Screw $9/64(40) \times 7$ .....	2	2	2	2	2	2
32	MN 70A0 131	油受け板	Oil guard plate.....	1	1	1	1	1	1
33	MN 70A0 740	フェルト	Felt.....	1	1	1	1	1	1
34	M9 0422 050	フエ座	Washer 4.....	2	2	2	2	2	2
35	MN 70A0 830	前面板	Face plate.....	1	1	1	1	1	1

② 上糸調節器部分(国内用) (I)

THREAD TENSION REGULATOR MECHANISM (Domestic only) (I)

901

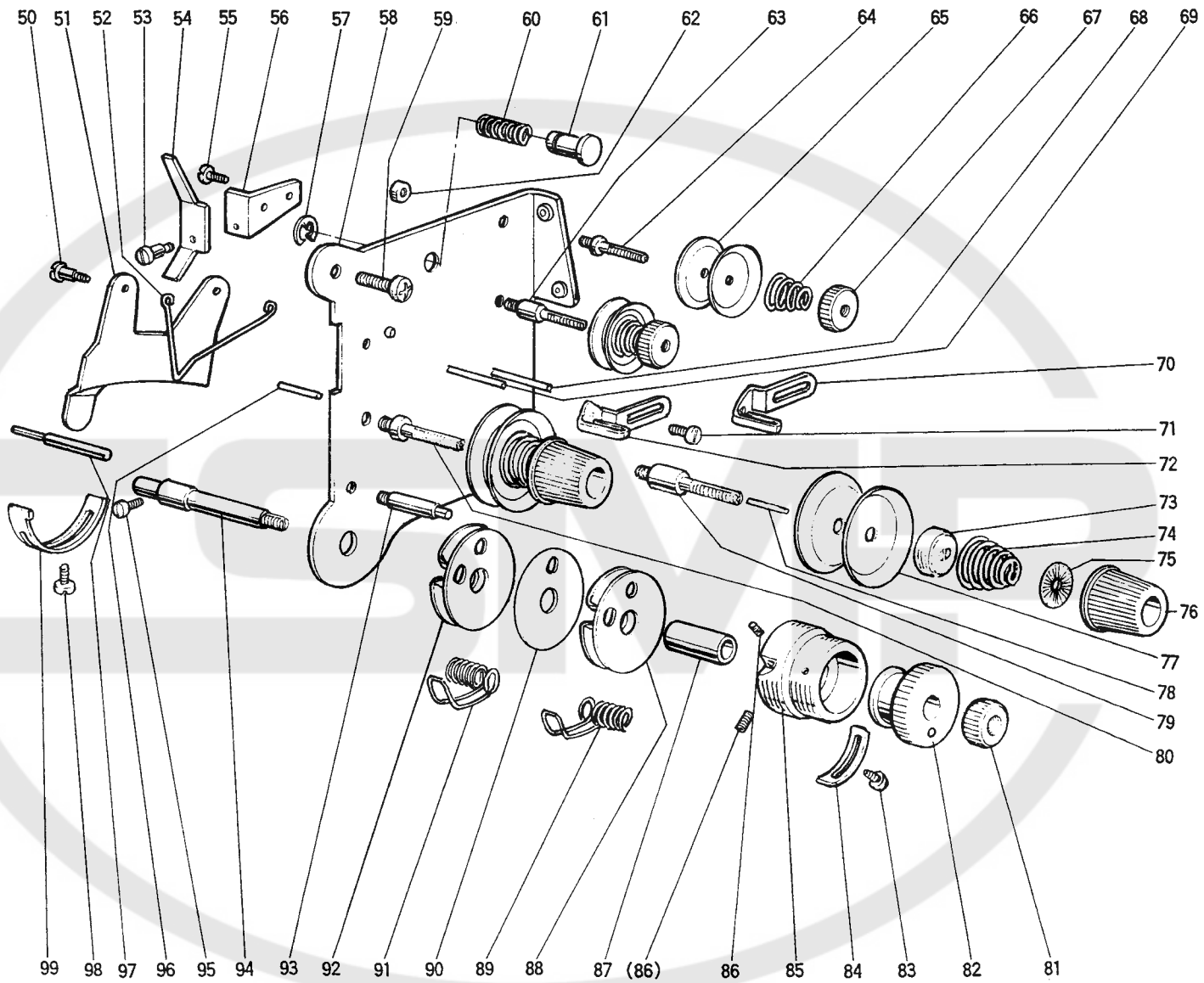

② 上糸調節器部分(国内用) (I)

THREAD TENSION REGULATOR MECHANISM (Domestic only) (I)

Fig. No.	部品コード Part No.	部 品 名	Description	使用個数 Amt. Req.					
				LT2-2220			LT2-2230		
				LOB	MOB	BOB	LT	M1TW	B1T
901	MN 68E0 210	上糸調節器組	(国内のみ) Thread tension regulator complete ...	1					
	MN 70E0 210	上糸調節器組	(国内のみ) Thread tension regulator complete ...		1				
	MN 69E0 210	上糸調節器組	(国内のみ) Thread tension regulator complete ...			1			
	MN 73E0 210	上糸調節器組	(国内のみ) Thread tension regulator complete ...				1		
	MN 72E0 210	上糸調節器組	(国内のみ) Thread tension regulator complete ...					1	
	MN 74E0 210	上糸調節器組	(国内のみ) Thread tension regulator complete ...						1
50	M9 0902 015	平ネジ	9/64(40)×3 Screw 9/64(40)×3	2	2	2	2	2	2
51	MN 50E0 220	セユルメ	Tension releasing plate	1	1	1	1	1	1
52	MN 10A0 851	センサイクバネ	Tension releasing spring	1	1	1	1	1	1
53	M9 0927 015	平ネジ	9/64(40)×4.2 Screw 9/64(40)×4.2				1	1	1
54	MN 72A0 950	レバ	Lever				1	1	1
55	M9 0906 002	平取付板	9/64(40)×4.5 Screw 9/64(40)×4.5				1	1	1
56	MN 50A6 601	取付板	Mounting plate				1	1	1
57	M9 0505 065	E形止メ	5 E-type stopring 5				1	1	1
58	MN 70A0 601	取付板	Mounting plate	1	1	1	1	1	1
59	M9 1106 004	ブラマイネジ	11/64(40)×8 Screw 11/64(40)×8	2	2	2	2	2	2
60	MN 50A4 572	ツル巻バネ	Spring				1	1	1
61	MP 41A1 270	押しボタ	Push button				1	1	1
62	M9 1105 045	ナット	11/64(40) Nut 11/64(40)	2	2	2	2	2	2
63	MN 70A1 553	調子棒	Thread tension stud	1	1	1	1	1	1
64	MN 70A0 553	調子棒	Thread tension stud	1	1	1	1	1	1
65	MF 10A1 555	調子皿	Thread tension disc	4	4	4	4	4	4
66	MN 70A0 245	エンスイバネ	Spring	2	2	2	2	2	2
67	M9 1101 046	マシナット	11/64(40) Thumb nut 11/64(40)	2	2	2	2	2	2
68	M9 7007 060	ピン	Pin	1	1	1	1	1	1
69	M9 0205 060	ピン	Pin	1	1	1	1	1	1
70	MN 69A0 181	糸案内	Thread guide			1			1
71	M9 0909 003	平ネジ	9/64(40)×6 Screw 9/64(40)×6	1	1	1	1	1	1
72	MN 70A2 181	糸案内	Thread guide	1	1		1	1	
73	MM11A0 556	調子皿	Thread tension releasing disc	2	2	2	2	2	2
74	MT 60A0 245	エンスイバネ	Spring	1			1		
	MN 10A3 245	エンスイバネ	Spring		1			1	
	MN 52A1 245	エンスイバネ	Spring			1			1
75	MT 60A0 802	回止メ	Thumb nut revolution stopper	2	2	2	2	2	2
76	M9 1610 046	マシナット	1/4(40) Thumb nut 1/4(40)	2	2	2	2	2	2
77	MF 10A0 555	調子皿	Thread tension disc	4	4	4	4	4	4
78	M9 7008 060	ピン	Pin	1	1	1	1	1	1
79	MN 70A3 553	調子棒	Thread tension stud	1	1	1	1	1	1
80	MN 70A2 553	調子棒	Thread tension stud	1	1	1	1	1	1
81	M9 1611 046	マシナット	1/4(40) Thumb nut 1/4(40)	1	1	1	1	1	1
82	MN 70A0 573	ツマミ	Take-up spring guide	1	1	1	1	1	1
83	M9 0915 003	平ネジ	9/64(40)×6 Screw 9/64(40)×6	1	1	1	1	1	1
84	MN 70A0 477	ストップ	Stopper	1	1	1	1	1	1
85	MN 70A0 154	アンナイガネ	Thread tension post	1	1	1	1	1	1
86	M9 0802 001	止メネジ	1/8(44)×3.9 Screw 1/8(44)×3.9	2	2	2	2	2	2
87	MN 70A0 750	ブッシュ	Bush	1	1	1	1	1	1
88	MN 70E1 175	板組	Plate complete	1	1	1	1	1	1
89	MN 70A1 187	糸取りバネ	Thread take-up spring	1	1	1	1	1	1
90	MN 70A0 308	板	Plate	1	1	1	1	1	1
91	MN 70A0 187	糸取りバネ	Thread take-up spring	1	1	1	1	1	1
92	MN 70E0 175	板組	Plate complete	1	1	1	1	1	1
93	M9 0928 015	段付ネジ	9/64(40)×2.9 Screw 9/64(40)×2.9	1	1	1	1	1	1
94	MN 70A0 554	調子棒	Thread tension stud	1	1	1	1	1	1
95	M9 0910 003	丸平ネジ	9/64(40)×7 Screw 9/64(40)×7	1	1	1	1	1	1
96	M9 7009 060	ピン	Pin	1	1	1	1	1	1
97	M9 0516 060	糸ユルメピン	Tension releasing pin				1	1	1
	M9 7010 060	糸ユルメピン	Tension releasing pin	1	1	1			
98	M9 0906 002	平ネジ	9/64(40)×4.5 Screw 9/64(40)×4.5	1	1	1	1	1	1
99	MN 10A0 477	ストップ	Stopper	1	1	1	1	1	1

③ 上糸調節器部分(輸出用) (II)

THREAD TENSION REGULATOR MECHANISM (Export only) (II)

LT2-2230

903

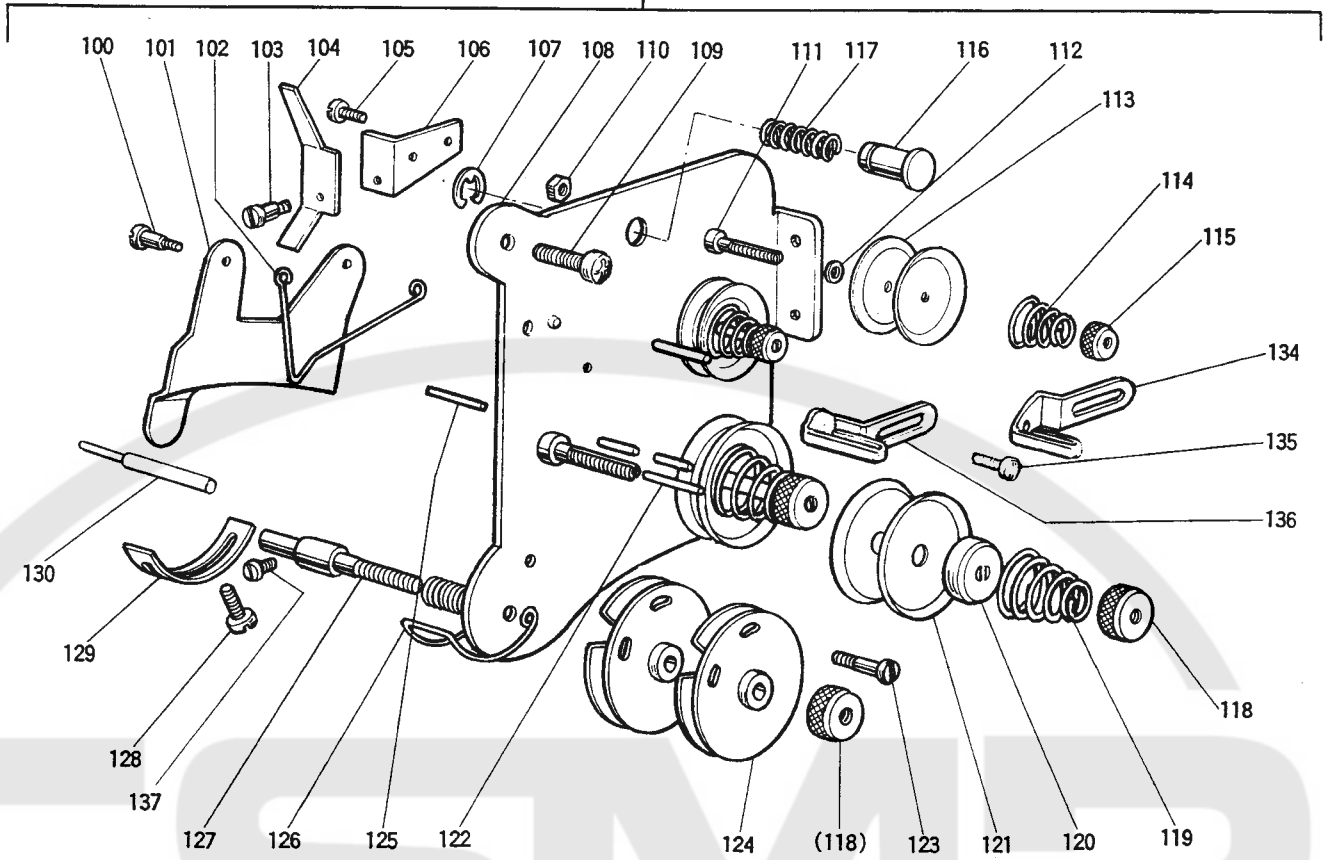

LT2-2220

902

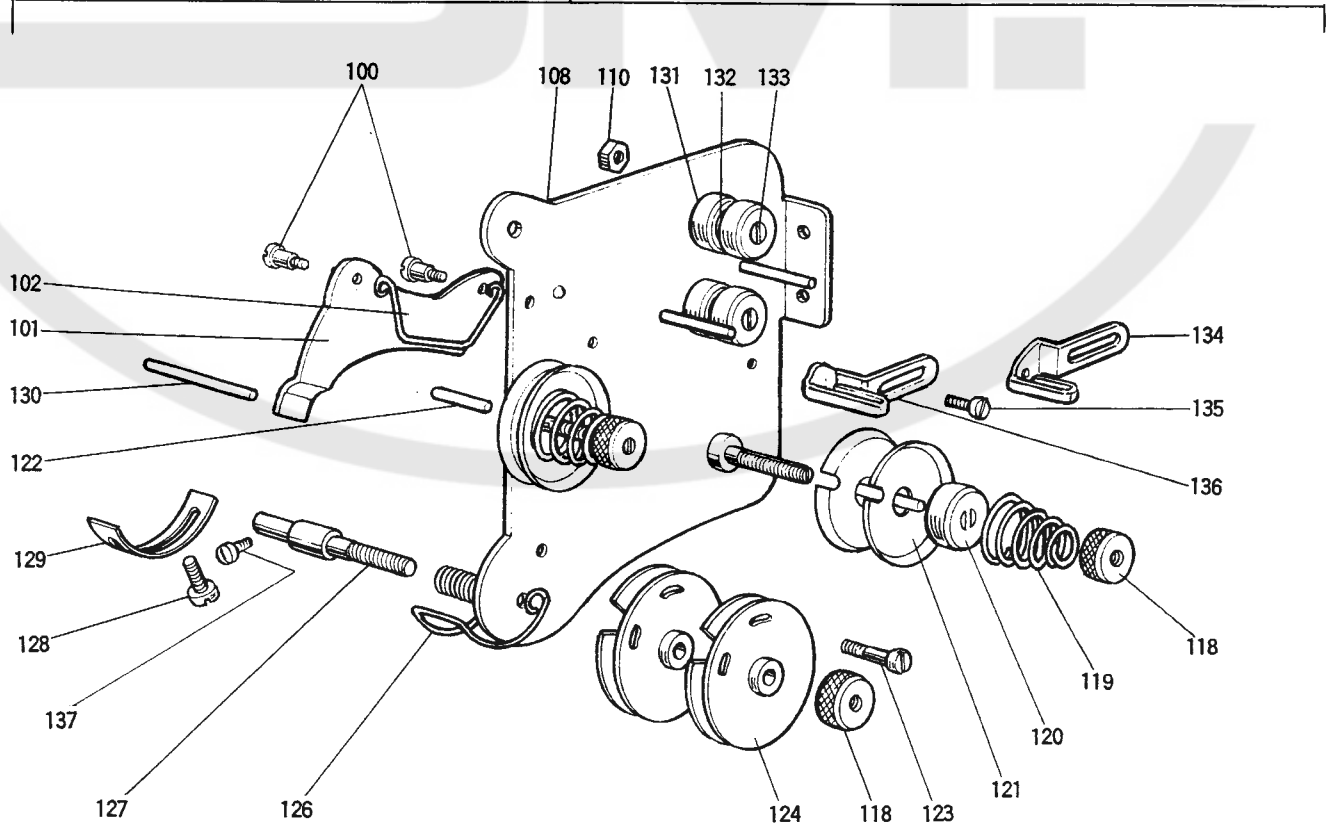

③ 上糸調節器部分(輸出用) (II)

THREAD TENSION REGULATOR MECHANISM (Export only) (II)

Fig. No.	部品コード Part. No.	部 品 名	Description	使用個数 Amt. Req.						
				LT2-2220			LT2-2230			
				LOB	MOB	BOB	LIT	MITW	BIT	
902	MN 68E1 210	上糸調節器組	Thread tension regulator complete	1						
	MN 70E1 210	上糸調節器組	Thread tension regulator complete		1					
	MN 69E1 210	上糸調節器組	Thread tension regulator complete			1				
903	MN 73E1 210	上糸調節器組	Thread tension regulator complete				1			
	MN 72E1 210	上糸調節器組	Thread tension regulator complete					1		
	MN 74E1 210	上糸調節器組	Thread tension regulator complete							1
100	M9 0902 015	平ネジ段付	Screw 9/64(40)	2	2	2	2	2	2	2
101	MN 10A0 220	糸ユルメ	Tension releasing plate	1	1	1		1	1	1
	MN 50E0 220	糸ユルメ	Tension releasing plate					1	1	1
102	MN 10A0 851	センサイクバネ	Tension releasing spring	1	1	1	1	1	1	1
103	M9 0927 015	平ネジ段付	Screw 9/64(40)×4.2				1	1	1	1
104	MN 72A0 950	レバ	Lever				1	1	1	1
105	M9 0906 002	平ネジ	Screw 9/64(40)×4.5				1	1	1	1
106	MN 50A6 601	取付板	Mounting plate				1	1	1	1
107	M9 0505 065	E形止メ輪	E-type stoping 5				1	1	1	1
108	MN 70E0 601	取付板組立	Mounting plate complete	1	1	1				
	MN 72E0 601	取付板組立	Mounting plate complete				1	1	1	1
109	M9 1106 004	ブラマイネジ	Screw 11/64(40)×8	1	1	1	1	1	1	1
110	M9 0901 045	ナット	Nut 9/64(40)	2	2	2				
	M9 1105 045	ナット	Nut 11/64(40)				1	1	1	1
111	MF 10A1 553	調節子	Thread tension stud				2	2	2	2
112	M9 0401 050	座金	Washer 4				1	1	1	1
113	MN 50A0 555	調節子	Thread tension disc				4	4	4	4
114	MN 50A1 245	エンスイバネ	Spring				2	2	2	2
115	M9 1609 046	エツマナット	Thumb nut 1/4(40)				2	2	2	2
116	MP 41A1 270	押しボタン	Push button				1	1	1	1
117	MN 50A4 572	ツル巻バネ	Spring				1	1	1	1
118	M9 1603 046	ツルミナット	Thumb nut 1/4(40)				3	3	3	3
119	MN 10A3 245	エンスイバネ	Spring		2				2	
	MF 10A0 245	エンスイバネ	Spring			2				
	MN 52A1 245	エンスイバネ	Spring							2
	MT 60A0 245	エンスイバネ	Spring	2			2			
120	MN 10A0 556	調節子皿押工	Thread tension releasing disc	2	2	2	2	2	2	2
121	MN 10A0 555	調節子皿	Thread tension disc	4	4	4	4	4	4	4
122	M9 0202 060	ピン	Pin	1	1	1	1	1	1	1
123	M9 0603 003	丸平ネジ	Screw 3/32(56)×12	1	1	1	1	1	1	1
124	MN 10E0 175	板組立	Plate complete	2	2	2	2	2	2	2
125	MN 25A0 220	ピン	Pin	1	1	1	1	1	1	1
126	MN 10A0 187	糸取りバネ	Thread take-up spring	1	1	1	1	1	1	1
127	MN 10A0 554	調節子軸	Tension tension stud	1	1	1	1	1	1	1
128	M9 0906 002	平ネジ	Screw 9/64(40)×4.5	1	1	1	1	1	1	1
129	MN 10A0 447	ストッパ	Stopper	1	1	1	1	1	1	1
130	M9 0521 060	糸ユルメピン	Tension releasing pin	1	1	1				
	M9 0516 060	糸ユルメピン	Tension releasing pin				1	1	1	1
131	MN 10A0 155	案内台	Thread guide bracket	2	2	2				
132	MN 10A1 555	案内子皿	Thread guide disc	2	2	2				
133	M9 0930 016	丸平ネジ段付(組)	Screw (complete)	2	2	2				
134	MN 69A0 181	糸案内	Thread guide				1			1
135	M9 0909 003	丸平ネジ	Screw 9/64(40)×6	1	1	1	1	1	1	1
136	MN 70A2 181	糸案内	Thread guide	1	1		1	1		
137	M9 0910 003	丸平ネジ	Screw 9/64(40)×7	1	1	1	1	1	1	1

④ 上軸・押え・ひざ上げ機構

UPPER SHAFT & PRESSER FOOT MECHANISM

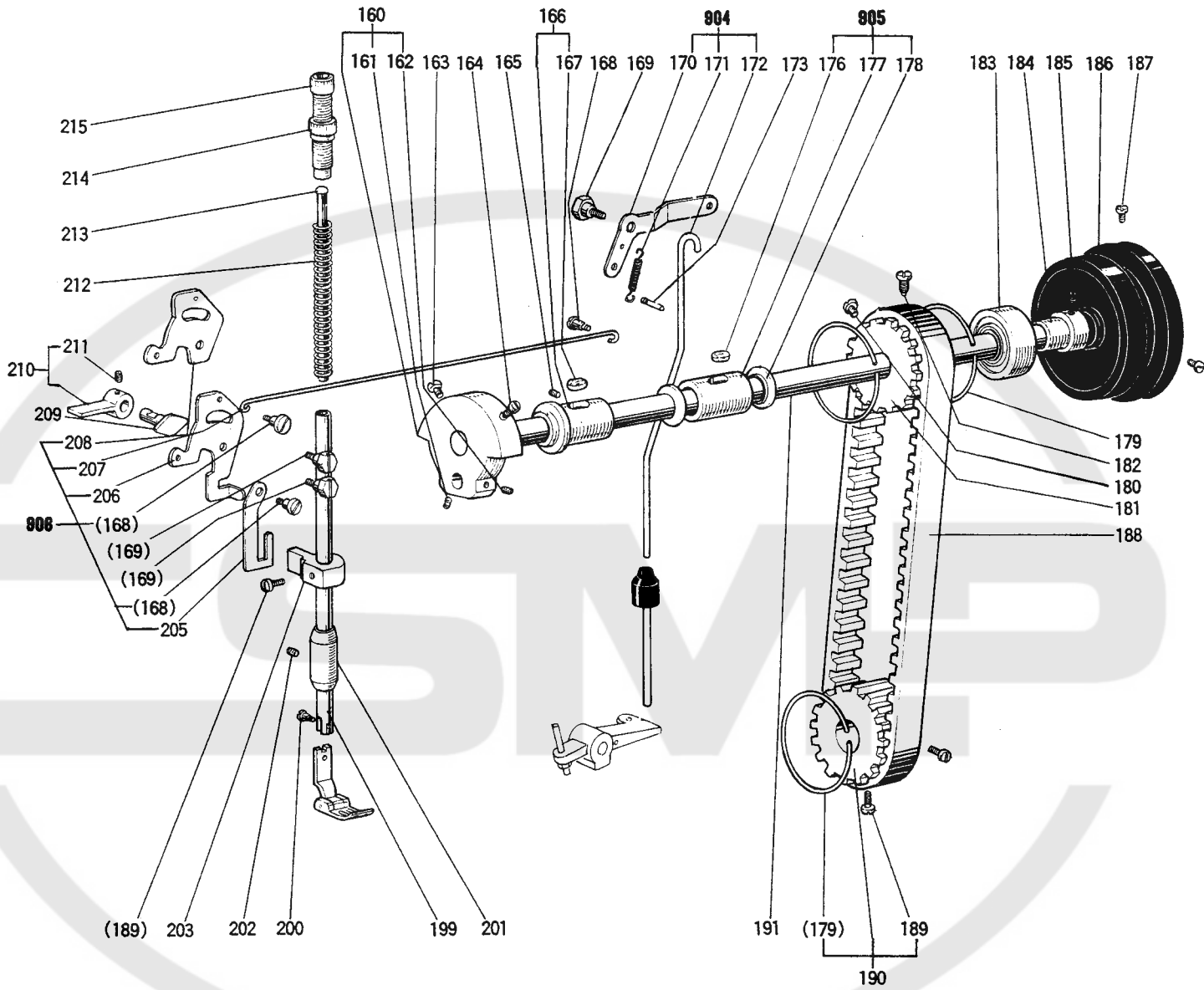



4 上軸・押え・ひざ上げ機構

UPPER SHAFT & PRESSER FOOT MECHANISM

Fig. No.	部品コード Part. No.	部 品 名	Description	使用個数 Amt. Req.					
				LT2-2220			LT2-2230		
				UB	MOB	BOB	LT	MTW	BIT
160	ML 65B0 383	ク ラ ン ク (組)	Crank (complete)	1	1		1	1	
	MN 42A0 383	ク ラ ン ク (組)	Crank (complete)			1			1
161	M9 1602 001	止 メ ネ ジ 1/4(40)×4	Screw 1/4(40)×4	1	1	1	1	1	1
162	M9 1606 001	止 メ ネ ジ 1/4(40)×6	Screw 1/4(40)×6	1	1	1	1	1	1
163	M9 1801 002	平 ネ ジ 9/32(28)×13	Screw 9/32(28)×13	1	1	1	1	1	1
164	M9 1802 006	平 ネ ジ 棒 先 9/32(28)×14	Screw 9/32(28)×14	1	1	1	1	1	1
165	M9 1516 001	止 メ ネ ジ 15/64(28)×14	Screw 15/64(28)×14	1	1	1	1	1	1
166	MN 70A0 232	上 軸 メ タ ル 左(組)	Arm shaft bushing left (complete)	1	1	1	1	1	1
167	MN 10A6 740	フ ェ ル ト	Felt	1	1	1	1	1	1
168	M9 1219 015	平 ネ ジ 段 付 3/16(28)×3.5	Screw 3/16(28)×3.5	3	3	3	3	3	3
169	M9 1503 031	ボ ル ト 15/64(28)×6.7	Bolt 15/64(28)×6.7	3	3	3	3	3	3
904	MN 70E0 252	押 上 ゲ レ バ ー 右 (組)	Knee lifter lever right (complete)	1	1	1	1	1	1
170	MN 70A0 252	押 上 ゲ レ バ ー (右)	Knee lifter lever (right)	1	1	1	1	1	1
171	MN 70A0 572	ツ ル 巻 キ バ ネ	Spring	1	1	1	1	1	1
172	MN 70A0 511	操 作 棒	Knee lifter connecting rod	1	1	1	1	1	1
173	M9 5004 067	溝 付 ピ ン (BX形)φ5×28	Pin φ5×28	1	1	1	1	1	1
905	MN 70E0 234	上 軸 メ タ ル 中 (組)	Arm shaft bushing middle (complete)	1	1		1	1	
176		フ ェ ル ト	Felt	1	1		1	1	
177		上 軸 メ タ ル 中	Arm shaft bushing (middle)	1	1		1	1	
178		オ イ ル シ ー ル	Oil seal	2	2		2	2	
179	MN 10A1 851	セ ン サ イ ク バ ネ	Spring flange	3	3	3	3	3	3
180	M9 1516 002	平 ネ ジ 15/64(28)×8.5	Screw 15/64(28)×8.5	1	1	1	1	1	1
181	MN 40A0 767	歯 形 ベ ル ト 車 (上)	Pulley (upper)	1	1				
	MN 50A0 767	歯 形 ベ ル ト 車 (上)	Pulley (upper)				1	1	1
182	M9 1501 007	丸 平 ネ ジ 棒 先 15/64(28)×14.5	Screw 15/64(28)×14.5	1	1	1	1	1	1
183	MN 70A0 456	軸 受 ケ	Ball bearing	1	1				
184	MN 40A1 750	ブ ッ シ ュ	Bushing	1	1				
185	M9 1516 002	平 ネ ジ 15/64(28)×8.5	Screw 15/64(28)×8.5	2	2	2			
186	MN 70E0 682	プ ー リ	Pulley	1	1				
187	M9 1502 002	平 ネ ジ 15/64(28)×12	Screw 15/64(28)×12	2	2				
188	MN 10A0 523	歯 形 ベ ル ト	Cog belt	1	1		1	1	1
189	M9 1515 002	平 ネ ジ 15/64(28)×10	Screw 15/64(28)×10	3	3	3	3	3	3
190	MN 70A0 768	歯 形 ベ ル ト 車 組(下)	Pulley complete (lower)	1	1	1			
	MN 72A0 768	歯 形 ベ ル ト 車 組(下)	Pulley complete (lower)				1	1	1
191	MN 70A0 230	上 軸	Arm shaft	1	1	1			
	MN 72A0 230	上 軸	Arm shaft				1	1	1
199	MN 70A0 262	押 エ 棒	Presser bar	1	1	1	1	1	1
200	M9 0851 015	平 ネ ジ 段 付 1/8(44)×4	Screw 1/8(44)×4	1	1	1	1	1	1
201	MF 00A0 267	押 エ 棒 メ タ ル	Bushing	1	1	1	1	1	1
202	M9 1513 001	止 メ ネ ジ 15/64(28)×10	Screw 15/64(28)×10	1	1	1	1	1	1
203	MN 70A0 265	押 エ 棒 ダ キ	Presser bar guide bracket	1	1	1	1	1	1
906	MN 70E1 252	押 上 ゲ レ バ ー 左 (組)	Knee lifter lever left (complete)	1	1	1			
	MN 72E0 252	押 上 ゲ レ バ ー 左 (組)	Knee lifter lever left (complete)				1	1	1
205	MN 70A0 510	操 作 板	Operation plate	1	1	1	1	1	1
206	MN 70A1 252	押 上 ゲ レ バ ー 左	Knee lifter lever left	1	1	1			
207	MN 70A0 738	引 棒	Knee lifter rod	1	1	1	1	1	1
208	MN 72A1 252	押 上 ゲ レ バ ー 左	Knee lifter lever left				1	1	1
209	MN 70A0 253	押 エ 上 ゲ カ ム	Presser bar lifting cam	1	1	1	1	1	1
210	MN 70A2 252	押 エ 上 ゲ (組)	Presser bar lifter (complete)	1	1	1	1	1	1
211	M9 1109 001	止 メ ネ ジ 11/64(40)×6.6	Screw 11/64(40)×6.6	2	2	2	2	2	2
212	MF 12B0 259	ツ ル 巻 キ バ ネ	Spring	1	1	1	1	1	1
213	MF 20A0 703	案 内 棒	Presser spring guide	1	1	1	1	1	1
214	M9 3202 047	特 殊 ナ ッ ト 1/2(28)	Special nut 1/2(28)	1	1	1	1	1	1
215	M9 3202 045	ツ マ ミ ネ ジ 1/2(28)×49	Thumb nut 1/2(28)×49	1	1	1	1	1	1

⑤ 天秤・針棒揺動機構  
 THREAD TAKE-UP LEVER & NEEDLE BAR  
 ROCK MOTION MECHANISM

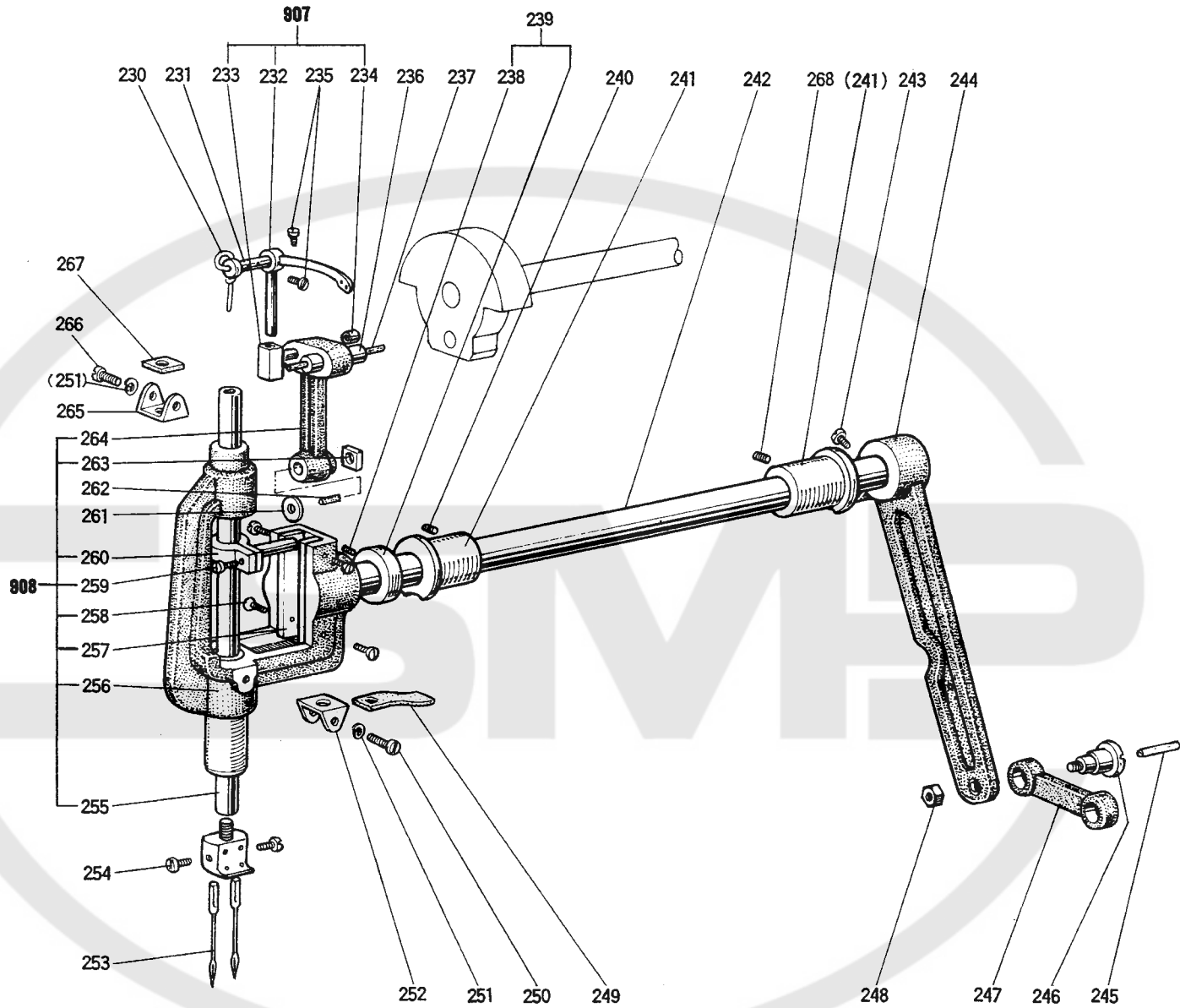

⑤ 天秤・針棒揺動機構

THREAD TAKE-UP LEVER & NEEDLE BAR  
ROCK MOTION MECHANISM

Fig. No.	部品コード Part No.	部 品 名	Description	使用個数 Amt. Req.					
				LT2-2220	LT2-2230				
				LOB	MOB	BOB	LIT	MITW	BIT
230	MF 10E2 148	ヒ モ	φ2.5×240..... Oil wick φ2.5×240.....	1	1	1	1	1	1
231	MN 70A0 587	天ピン支工軸	..... Thread take-up guide bracket pin....	1	1	1	1	1	1
907	MN 68E0 582	天ピン・スベリガネ	(組)..... Thread take-up lever & link (complete)....	1			1		1
	MN 70E0 582	天ピン・スベリガネ	(組)..... Thread take-up lever & link (complete)....		1			1	
	MN 69E0 582	天ピン・スベリガネ	(組)..... Thread take-up lever & link (complete)....			1			1
232	_____	天ビニン	..... Thread take-up lever.....	1			1		
	_____	天ビニン	..... Thread take-up lever.....		1			1	
	_____	天ビニン	..... Thread take-up lever.....			1			1
233	_____	スベリガネ	..... Thread take-up link.....	1	1		1	1	
	_____	スベリガネ	..... Thread take-up link.....			1			1
234	MN 10A0 500	セネン	..... Plug.....	1	1	1	1	1	1
235	M9 1502 002	平ネジ	<sup>15</sup> / <sub>64</sub> (28)×12..... Screw <sup>15</sup> / <sub>64</sub> (28)×12.....	3	3	3	3	3	3
236	MN 70A0 387	針棒クランク軸	..... Needle bar crank pin.....	1	1	1	1	1	1
237	MN 10E3 148	針モ	φ3.0×25..... Oil wick φ3.0×25.....	1	1	1	1	1	1
238	M9 1606 001	止メネジ	<sup>11</sup> / <sub>64</sub> (40)×6..... Screw <sup>11</sup> / <sub>64</sub> (40)×6.....	1	1	1	1	1	1
239	MN 70A0 352	カ ラ ー	(組)..... Collar (complete).....	1	1	1	1	1	1
240	M9 1506 001	止メネジ	<sup>15</sup> / <sub>64</sub> (28)×7..... Screw <sup>15</sup> / <sub>64</sub> (28)×7.....	1	1	1	1	1	1
241	MN 40A0 669	針棒揺動軸メタル	..... Needle bar rock shaft bushing..	2	2	2	2	2	2
242	MN 70A0 668	針棒揺動軸	..... Needle bar rock shaft.....	1	1	1	1	1	1
243	M9 1603 003	丸平ネジ	<sup>1</sup> / <sub>4</sub> (24)×16..... Screw <sup>1</sup> / <sub>4</sub> (24)×16.....	1	1	1	1	1	1
244	MN 40A1 762	針棒揺動腕	..... Needle bar rock shaft crank.....	1	1	1	1	1	1
245	MF 10E2 148	ヒモ	φ2.5×85..... Oil wick φ2.5×85.....	1	1	1	1	1	1
246	M9 2001 015	平ネジ段付	<sup>5</sup> / <sub>16</sub> (24)×26..... Screw <sup>5</sup> / <sub>16</sub> (24)×26.....	1	1	1	1	1	1
247	MN 40A0 956	レンセツカント	..... Link.....	1	1	1	1	1	1
248	M9 2002 045	レンセツカント	<sup>5</sup> / <sub>16</sub> (24)..... Nut <sup>5</sup> / <sub>16</sub> (24).....	1	1	1	1	1	1
249	MN 50A0 740	フェルト	..... Felt.....	1	1	1	1	1	1
250	M9 0805 002	平バネ	<sup>1</sup> / <sub>8</sub> (44)×4.5..... Screw <sup>1</sup> / <sub>8</sub> (44)×4.5.....	2	2	2	2	2	2
251	M9 0301 053	ネ座	3..... Spring washer 3.....	4	4	4	4	4	4
252	MN 10A6 689	ホルダ	..... Holder.....	1	1	1	1	1	1
253	MN 68A0 128	シンピン針	DP×5 #11..... Needle DP×5 #11.....	2			2		
	MV 01A0 128	シンピン針	DP×5 #14..... Needle DP×5 #14.....		2			2	
	MN 10A1 128	シンピン針	DP×5 #18..... Needle DP×5 #18.....			2			2
254	M9 0935 003	丸平ネジ	<sup>9</sup> / <sub>64</sub> (40)×4..... Screw <sup>9</sup> / <sub>64</sub> (40)×4.....	2	2	2	2	2	2
908	MN 70E0 666	支工棒	(組)..... Needle bar rock frame (complete) ..	1	1	1	1	1	1
255	MN 10A0 660	針棒	..... Needle bar.....	1	1	1	1	1	1
256	_____	支工棒	..... Needle bar rock frame.....	1	1	1	1	1	1
257	_____	スベリ	..... Spacer.....	2	2	2	2	2	2
258	M9 0604 011	丸皿ネジ	<sup>3</sup> / <sub>32</sub> (56)×4..... Screw <sup>3</sup> / <sub>32</sub> (56)×4.....	4	4	4	4	4	4
259	M9 0905 002	丸皿ネジ	<sup>9</sup> / <sub>64</sub> (40)×8.5..... Screw <sup>9</sup> / <sub>64</sub> (40)×8.5.....	1	1	1	1	1	1
260	_____	針棒ダキ	..... Needle bar connecting stud.....	1	1	1	1	1	1
261	M9 3003 050	座金	..... Washer.....	1	1	1	1	1	1
262	MN 10A0 740	フェルト	..... Felt.....	1	1	1	1	1	1
263	_____	角胸	..... Square block.....	1	1	1	1	1	1
264	_____	レンセツカント	..... Needle bar connecting link.....	1	1	1	1	1	1
265	MN 10A5 689	ホルダ	..... Holder.....	1	1	1	1	1	1
266	M9 0803 002	平ネジ	<sup>1</sup> / <sub>8</sub> (44)×3.5..... Screw <sup>1</sup> / <sub>8</sub> (44)×3.5.....	2	2	2	2	2	2
267	MN 40A1 740	フェルト	..... Felt.....	1	1	1	1	1	1
268	M9 1513 001	止メネジ	<sup>15</sup> / <sub>64</sub> (28)×10..... Screw <sup>15</sup> / <sub>64</sub> (28)×10.....	1	1	1	1	1	1

⑥ 縫目加減機構  
 STITCH REGULATOR MECHANISM

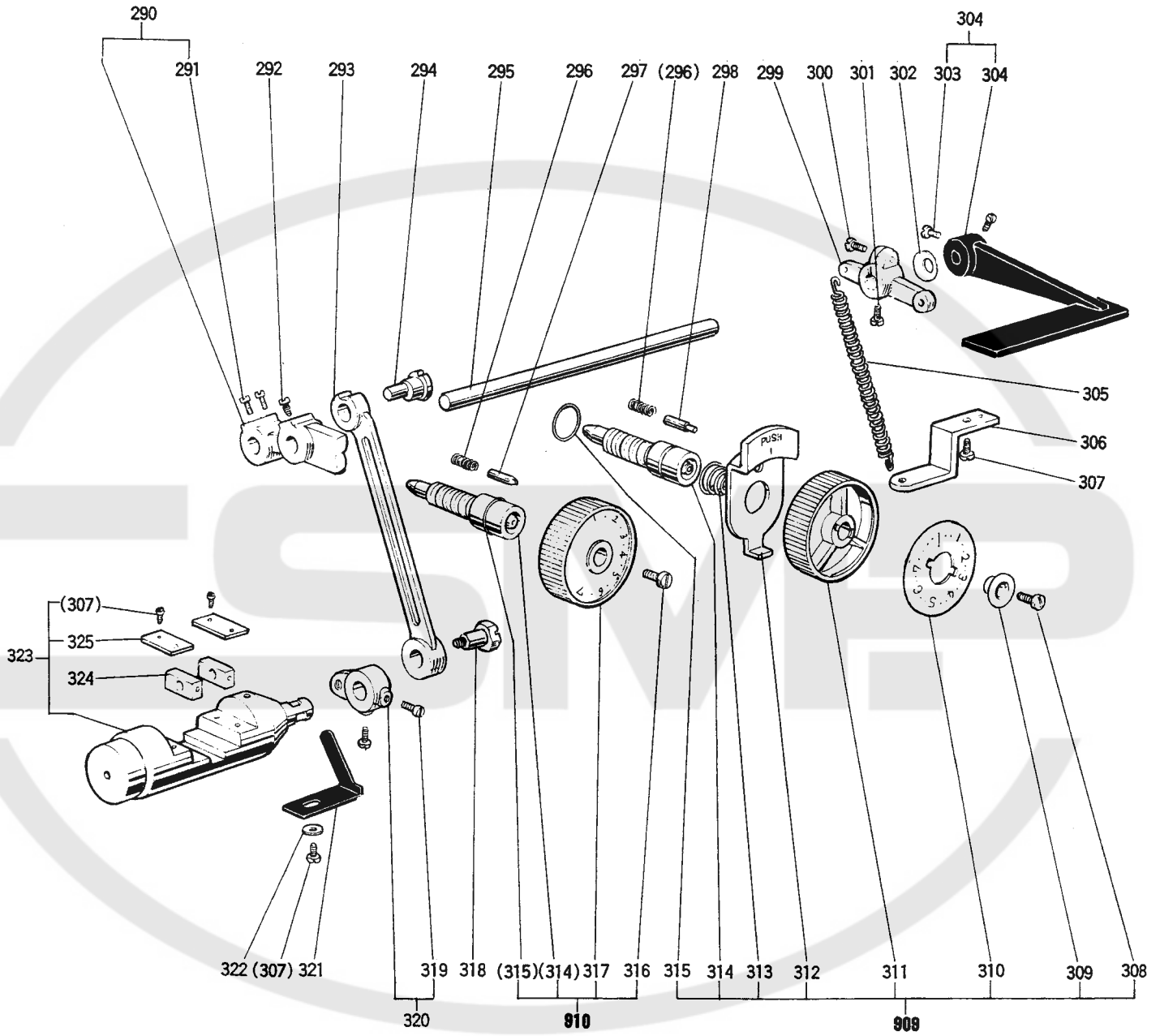

6 縫目加減機構

STITCH REGULATOR MECHANISM

Fig. No.	部品コード Part No.	部 品 名	Description	使用個数 Amt. Req.					
				LT2-2220			LT2-2230		
				LOB	MOB	BOB	LT	MITW	BIT
290	MN 70A0 291	送り調節カム (組)	Feed regulator (complete).....	1	1	1	1	1	1
291	M9 1516 002	平ネジ	$15/64(28) \times 8.5$ Screw $15/64(28) \times 8.5$ .....	2	2	2	2	2	2
292	M9 1505 007	丸平ネジ	$15/64(28) \times 12$ Screw $15/64(28) \times 12$ .....	1	1	1	1	1	1
293	MN 70A1 956	連接棒	Connecting link.....	1	1	1	1	1	1
294	MN 70A0 761	偏心軸	Eccentric shaft.....	1	1	1	1	1	1
295	MN 70A0 320	返し縫イ軸上	Reverse stitch shaft (upper).....	1	1	1			
	MN 72A0 320	返し縫イ軸上	Reverse stitch shaft (upper).....				1	1	1
296	MF 10A2 572	ツル巻キバネ	Spring.....	1	1	1	1	1	1
297	MF 80A0 852	ピン	Pin.....	1	1	1			
298	MF 00A0 852	ピン	Pin.....				1	1	1
299	MN 40A0 228	腕	Arm.....	1	1	1			
	MN 50A6 228	腕	Arm.....				1	1	1
300	M9 0508 003	丸平ネジ	$15/64(28) \times 16.5$ Screw $15/64(28) \times 16.5$ .....	1	1	1	1	1	1
301	M9 1102 002	平ネジ	$11/64(40) \times 8.5$ Screw $11/64(40) \times 8.5$ .....	1	1	1	1	1	1
302	M9 5003 053	平ネジ座	Spring washer.....	1	1	1			
303	M9 1516 002	丸平ネジ	$15/64(28) \times 8.5$ Screw $15/64(28) \times 8.5$ .....	2	2	2			
304	MN 70A0 632	縫目加減レバー (組)	Reverse sewing lever (complete).....	1	1	1			
	MN 72A0 632	縫目加減レバー	Reverse sewing lever.....				1	1	1
305	MN 40A0 572	ツル巻キバネ	Spring.....	1	1	1	1	1	1
306	MN 40A0 154	案内板	Bracket for spring.....	1	1	1			
307	M9 1106 004	ブラマイネジ	$11/64(40) \times 8$ Screw $11/64(40) \times 8$ .....	6	6	6	5	5	5
909	MN 72E0 640	送り調節ネジ組立	Screw bar complete.....				1	1	
	MN 74E0 640	送り調節ネジ組立	Screw bar complete.....						1
308	M9 1215 002	平ネジ	$3/16(28) \times 12$ Screw $3/16(28) \times 12$ .....				1	1	1
309	MF 00A0 257	押し工	Bushing.....				1	1	1
310	MF 01A0 841	目盛板	Stitch length indicating plate.....				1	1	
	MN 74A0 841	目盛板	Stitch length indicating plate.....						1
311	MF 01A0 631	ダイヤル	Dial.....				1	1	1
312	MF 00A0 950	レバ	Stopper pin releasing lever.....				1	1	1
313	MF 02A0 245	円錐バネ	Coil spring.....				1	1	1
314	MF 60A1 640	送り調節ネジ	Screw bar.....	1	1	1	1	1	1
315	M9 1000 085	オリン	O-ring $\phi 10$ .....	1	1	1	1	1	1
910	MN 70E0 640	送り調節ネジ組立	Screw bar complete.....	1	1				
	MN 69E0 640	送り調節ネジ組立	Screw bar complete.....				1		
316	M9 1209 002	平ネジ	$3/16(28) \times 8$ Screw $3/16(28) \times 8$ .....	1	1	1			
317	MN 70A0 631	ダイヤル	Dial.....	1	1				
	MN 69A0 631	ダイヤル	Dial.....				1		
318	M9 1607 031	特殊ボルト	$1/4(40) \times 8$ Bolt $1/4(40) \times 8$ .....	1	1	1	1	1	1
319	M9 1515 002	平ネジ	$15/64(28) \times 10$ Screw $15/64(28) \times 10$ .....	2	2	2	2	2	2
320	MN 70A0 634	縫目加減腕下 (組)	Stitch regulating crank lower (complete).....	1	1	1	1	1	1
321	MN 70A0 257	返し台押し工	Holding plate of reverse bar.....	1	1	1	1	1	1
322	M9 3002 050	返し座	Washer.....	1	1	1	1	1	1
323	MN 70A0 321	返しシ	Reverse bar (complete).....	1	1	1	1	1	1
324	MN 70A0 325	返角案内	Square block.....	2	2	2	2	2	2
325	MN 70A1 154	案内板	Guide plate.....	2	2	2	2	2	2

7 下軸・送り機構

LOWER SHAFT & FEED ROCK SHAFT MECHANISM

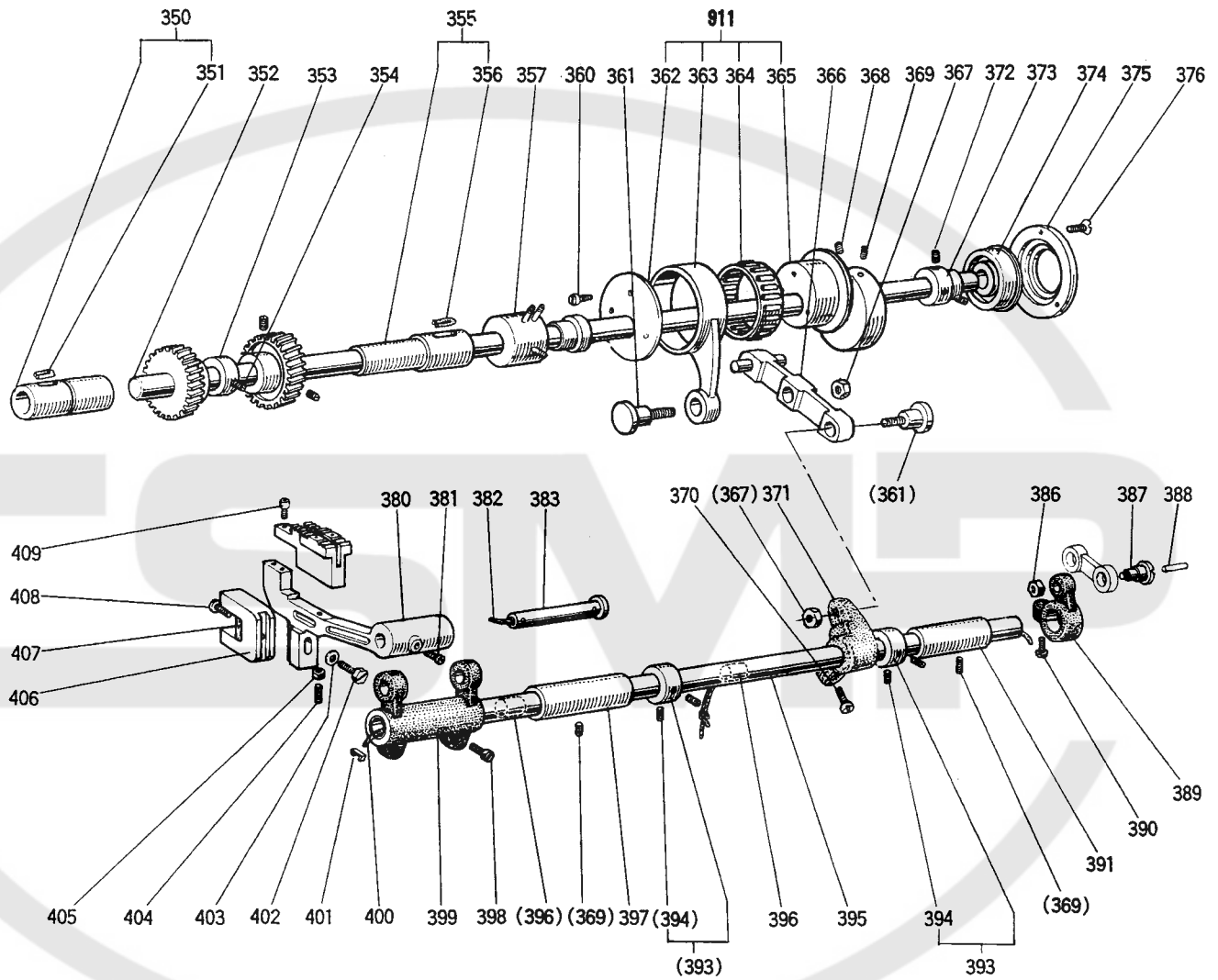

7 下軸・送り機構

LOWER SHAFT & FEED ROCK SHAFT MECHANISM

Fig. No.	部品コード Part. No.	部 品 名	Description	使用個数 Amt. Req.					
				LT2-2220			LT2-2230		
				LOB	MOB	BOB	L	M	BIT
350	MN 70A0 451	下軸メタル	左(組)..... Lower shaft bushing left (complete) .....	1	1	1	1	1	1
351	MN 70E1 148	下ヒモ	φ2×45..... Oil wick φ2×45.....	1	1	1	1	1	1
352	MN 70A0 450	下軸	..... Lower shaft .....	1	1	1	1	1	1
353	MN 70A0 760	下備心	..... Feed lifting cam.....	1	1	1	1	1	1
354	M9 1603 001	止メネジ	1/4(40)×5..... Screw 1/4(40)×5.....	1	1	1	1	1	1
355	MN 70A0 452	下軸メタル	右(組)..... Lower shaft bushing right (complete) .....	1	1	1	1	1	1
356	MN 70E1 148	下ヒモ	φ2×85..... Oil wick φ2×85.....	1	1	1	1	1	1
357	MN 70E0 453	下軸メタル	中(組)..... Lower shaft bushing middle (complete) .....	1	1	1	1	1	1
911	MN 70E0 290	水平送りカムロッド	(組)..... Level feed connecting rod (complete) ..	1	1		1	1	
	MN 69E0 290	水平送りカムロッド	(組)..... Level feed connecting rod (complete) ..			1			1
360	M9 1109 002	平ネジ	11/64(40)×7..... Screw 11/64(40)×7 .....	3	3	3	3	3	3
361	M9 1685 015	平ネジ	1/4(24)×13..... Screw 1/4(24)×13 .....	2	2	2	2	2	2
362		座金	..... Washer .....	1	1	1	1	1	1
363		送り口	..... Feed connecting rod .....	1	1	1	1	1	1
364		軸受	..... Needle bearing .....	1	1	1	1	1	1
365		水平送りカム	..... Level feed connecting cam .....	1	1		1	1	
		水平送りカム	..... Level feed connecting cam .....			1			1
366	MN 70E0 956	連接桿	(組)..... Link (complete) .....	1	1	1	1	1	1
367	M9 1601 045	ナット	1/4(24)..... Nut 1/4(24) .....	2	2	2	2	2	2
368	M9 1513 001	止メネジ	15/64(28)×10..... Screw 15/64(28)×10 .....	1	1	1	1	1	1
369	M9 1516 001	止メネジ	15/64(28)×14..... Screw 15/64(28)×14 .....	3	3	3	3	3	3
370	M9 1506 002	平ネジ	15/64(28)×14..... Screw 15/64(28)×14 .....	1	1	1	1	1	1
371	MN 70A0 273	送り腕	(中)..... Connecting rod crank (middle).....	1	1	1	1	1	1
372	M9 1606 001	止メネジ	1/4(40)×6..... Screw 1/4(40)×6 .....	2	2	2	2	2	2
373	MN 70A1 750	ブッシュ	..... Bushing .....	1	1	1	1	1	1
374	MN 70A2 456	軸受	..... Ball bearing .....	1	1	1	1	1	1
375	MN 70A0 771	軸押丸	..... Bearing holder .....	1	1	1	1	1	1
376	M9 0902 011	皿ネジ	9/64(40)×7..... Screw 9/64(40)×7 .....	3	3	3	3	3	3
380	MN 70A0 281	送り台	..... Feed bar .....	1	1	1			
	MN 72A0 281	送り台	..... Feed bar .....				1	1	1
381	M9 1102 002	平ネジ	11/64(40)×8.5..... Screw 11/64(40)×8.5 .....	1	1	1	1	1	1
382	MN 70E0 148	ヒモ	φ2.5×150..... Oil wick φ2.5×150 .....	1	1	1	1	1	1
383	MN 40A0 283	ツバ付軸	..... Feed bar shaft .....	1	1	1	1	1	1
386	M9 2001 045	平ネジ	5/16(24)..... Nut 5/16(24) .....	1	1	1	1	1	1
387	M9 2001 015	平ネジ	5/16(24)×6..... Screw 5/16(24)×6 .....	1	1	1	1	1	1
388	MF 10E2 148	ヒモ	φ2.5×85..... Oil wick φ2.5×85 .....	1	1	1	1	1	1
389	MN 40A0 279	水平送り腕	(右)..... Feed rock shaft crank (right).....	1	1	1	1	1	1
390	M9 1603 003	丸平ネジ	1/4(24)×16..... Screw 1/4(24)×16 .....	1	1	1	1	1	1
391	MN 70A0 287	送り軸メタル	(右)..... Feed rock shaft bushing (right) ..	1	1	1	1	1	1
393	MF 70A0 352	力ラ	(組)..... Collar (complete) .....	2	2	2	2	2	2
394	M9 1602 001	止メネジ	1/4(40)×4..... Screw 1/4(40)×4 .....	4	4	4	4	4	4
395	MN 40A0 491	水平送り軸	..... Feed rock shaft .....	1	1	1	1	1	1
396	MP 40A2 740	フェルト	..... Felt .....	2	2	2	2	2	2
397	MF 70A0 286	送り軸メタル	(左)..... Feed rock shaft bushing (left) ..	1	1	1	1	1	1
398	M9 1204 003	丸平ネジ	3/16(28)×12..... Screw 3/16(28)×12 .....	2	2	2	2	2	2
399	MN 40A0 278	水平送り腕	(左)..... Feed rock shaft crank (left) .....	1	1	1			
	MN 50A0 278	水平送り腕	(左)..... Feed rock shaft crank (left) .....				1	1	1
400	MN 70E0 148	ヒモ	φ2.5×430..... Oil wick φ2.5×430 .....	1	1	1	1	1	1
401	MF 80A0 780	ホルダ	..... Holder .....	1	1	1	1	1	1
402	M9 1511 022	ボルト	15/64(28)×13.5..... Bolt 15/64(28)×13.5 .....	1	1	1	1	1	1
403	M9 0607 050	座金	6..... Washer 6 .....	1	1	1	1	1	1
404	M9 0851 001	止メネジ	1/8(40)×15..... Screw 1/8(40)×15 .....	1	1	1	1	1	1
405	M9 0801 045	ナット	1/8(40)..... Nut 1/8(40) .....	1	1	1	1	1	1
406	MN 70A0 744	二又	..... Feed bar connecting fork ..	1	1		1	1	
	MN 69A0 744	二又	..... Feed bar connecting fork ..			1			1
407	MN 70A1 740	フェルト	..... Felt .....	1	1	1	1	1	1
408	M9 0804 003	丸平ネジ	1/8(44)×4..... Screw 1/8(44)×4 .....	1	1	1	1	1	1
409	M9 0803 020	六角穴付ボルト	1/8(40)×7..... Bolt 1/8(40)×7 .....	2	2	2	2	2	2

⑧ カマ台機構  
HOOK SADDLE MECHANISM

LT2-2220

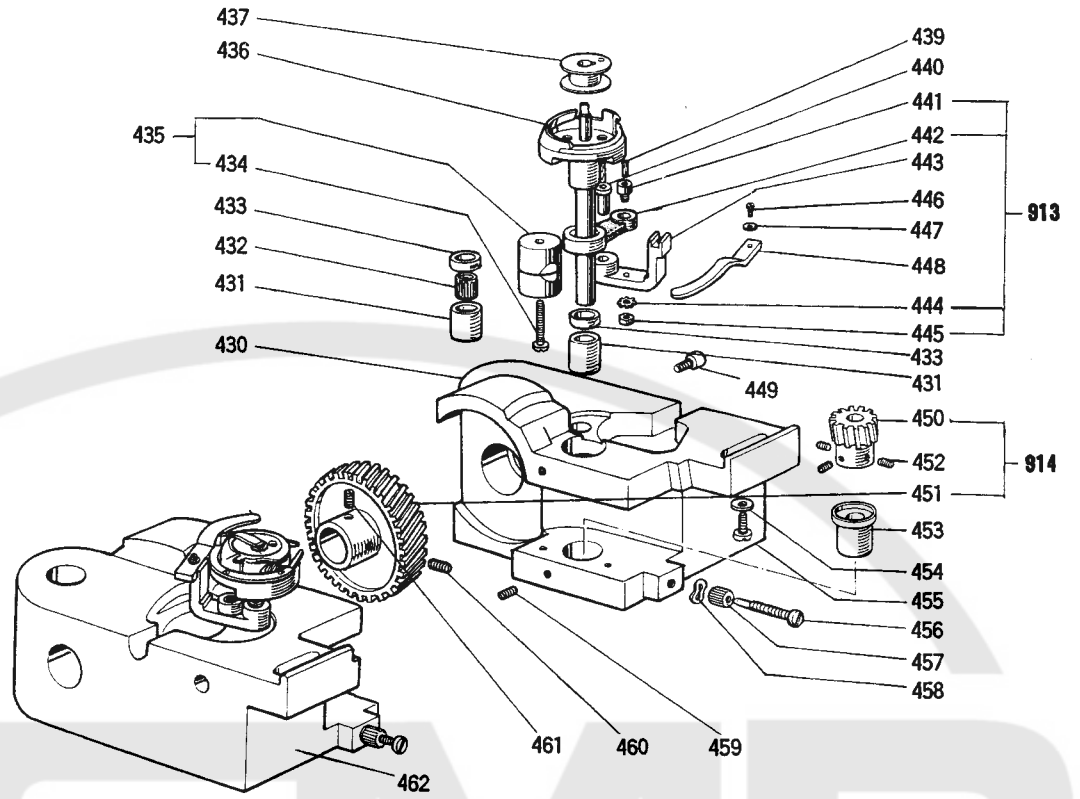

LT2-2230

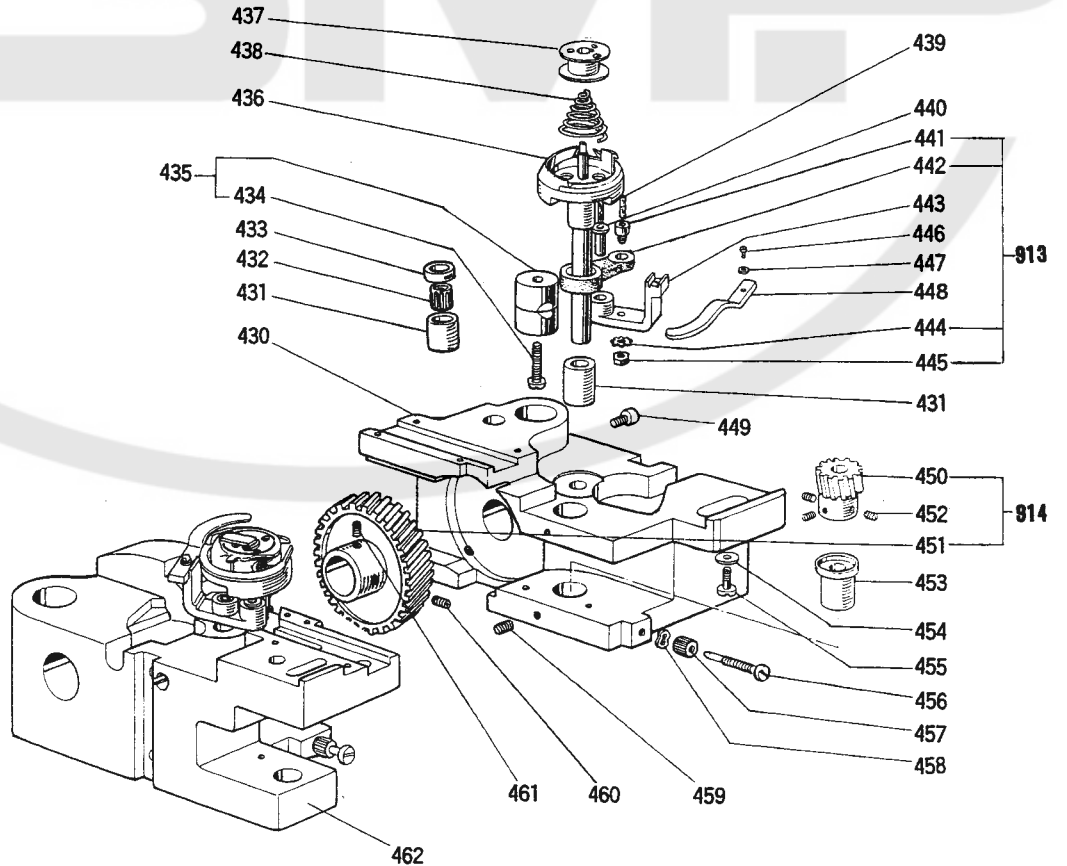



# 8 カマ台機構 HOOK SADDLE MECHANISM

Fig. No.	部品コード Part No.	部 品 名	Description	使用個数 Amt. Req.						
				LT2-2220			LT2-2230			
				LOB	MOB	BOB	LIT	MTTW	BIT	
430	MN 70A0 345	カ マ 台 (右)	Hook saddle (right)	1	1					
	MN 69A0 345	カ マ 台 (右)	Hook saddle (right)			1				
	MN 72A0 345	カ マ 台 (右)	Hook saddle (right)				1	1		
	MN 74A0 345	カ マ 台 (右)	Hook saddle (right)							1
431	MN 70A0 342	カ マ 軸 メ タ ル (上)	Hook shaft bushing (upper)	2	2		2	2		
	MN 69A0 342	カ マ 軸 メ タ ル (上)	Hook shaft bushing (upper)			2				2
432	MN 70A3 456	ジ ク ウ ケ	Needle bearing	2	2		2	2		
433	MN 70A0 476	ス ベ ー サ	Spacer	2	2		2	2		
	MN 69A0 476	ス ベ ー	Spacer			2				2
434	M9 1509 002	平 ネ ジ	Screw 15/64(28)×22	2	2	2	2	2	2	2
435	MN 70A2 750	ブ ッ シ ユ	Bushing (complete)	2	2	2	2	2	2	2
436	MN 10A0 120	カ カ マ (組)	Hook complete	2	2					
	MN 12E0 120	カ カ マ (組)	Hook complete			2				
	MN 72E0 120	カ カ マ (組)	Hook complete				2	2		
	MN 74E0 120	カ カ マ (組)	Hook complete							2
437	MN 40A0 123	ボ ビ ビ ン	Bobbin	2	2					
	MN 10B0 123	ボ ビ ビ ン	Bobbin			2				
	MN 72A0 123	ボ ビ ビ ン	Bobbin				2	2		
	MN 74A0 123	ボ ビ ビ ン	Bobbin							2
438	MN 50A2 245	エ ン ス イ バ ネ	Spring				2	2		
	MN 52A2 245	エ ン ス イ バ ネ	Spring							2
439	MF 10E0 148	ヒ	Oil wick φ2.5×15	2	2	2	2	2	2	2
440	MN 10A0 302	オ ー プ ナ 支 エ 軸	Bobbin case opener holder pin	2	2	2	2	2	2	2
913	MN 40E0 301	オ ー プ ナ 支 エ 組	Bobbin case opener holder complete	2	2		2	2		
	MN 10E0 301	オ ー プ ナ 支 エ 組	Bobbin case opener holder complete			2				2
441	M9 1254 030	特 殊 ネ ジ	Screw 3/16(32)×7.8	2	2	2	2	2	2	2
442	MN 10A0 340	連 接 桿	Link	2	2		2	2		
	MP 40A0 340	連 接 桿	Link			2				2
443	MN 10A0 301	オ ー プ ナ 支 エ	Bobbin case opener holder	2	2		2	2		
	MN 52A0 301	オ ー プ ナ 支 エ	Bobbin case opener holder			2				2
444	M9 0501 053	パ ネ 座 金	Spring washer 5	2	2	2	2	2	2	2
445	M9 1252 045	ナ ツ ト	Nut 3/16(32)×3.5	2	2	2	2	2	2	2
446	M9 0910 003	丸 平 ネ ジ	Screw 9/64(40)×7	2	2	2	2	2	2	2
447	M9 0401 050	座 ー プ 金	Washer	2	2	2	2	2	2	2
448	MN 50A0 300	オ ー プ ナ	Opener	2	2		2	2		
	MN 52A0 300	オ ー プ ナ	Opener			2				2
449	M9 1201 020	六角穴付止メネジ	Screw 3/16(28)×14.5	2	2	2	2	2	2	2
914	MN 70E0 644	ネ ジ 齒 車 (組)	Gear (complete)	2	2	2	2	2	2	2
450		ネ ジ 齒 車 (小)	Gear (small)	2	2	2	2	2	2	2
451		ネ ジ 齒 車 (大)	Gear (large)	2	2	2	2	2	2	2
452	M9 1602 001	止 メ ネ ジ	Screw 1/4(40)×4	6	6	6	6	6	6	6
453	MN 70A0 343	カ マ 軸 メ タ ル (下)	Hook shaft bushing(lower)	2	2	2	2	2	2	2
454	M9 0701 050	力 座 金	Washer	2	2	2	2	2	2	2
455	M9 1652 002	平 ネ ジ	Screw 1/4(24)×23	2	2	2	2	2	2	2
456	M9 1206 030	特 殊 ネ ジ	Screw 3/16(28)×26	2	2	2	2	2	2	2
457	M9 1206 045	ツ マ ミ ナ ッ ト	Nut 3/16(28)	2	2	2	2	2	2	2
458	M9 3005 050	バ ネ 座 金	Spring washer	2	2	2	2	2	2	2
459	M9 1503 001	止 メ ネ ジ	Screw 15/64(28)×4.5	4	4	4	4	4	4	4
460	M9 1606 001	止 メ ネ ジ	Screw 1/4(40)×6	2	2	2	2	2	2	2
461	M9 1655 001	止 メ ネ ジ	Screw 1/4(40)×6.5	2	2	2	2	2	2	2
462	MN 70A0 344	カ マ 台 (左)	Hook saddle (left)	1	1					
	MN 69A0 344	カ マ 台 (左)	Hook saddle (left)			1				
	MN 72A0 344	カ マ 台 (左)	Hook saddle (left)				1	1		
	MN 74A0 344	カ マ 台 (左)	Hook saddle (left)							1

9 糸切り機構 (I)  
KNIFE MECHANISM (I)

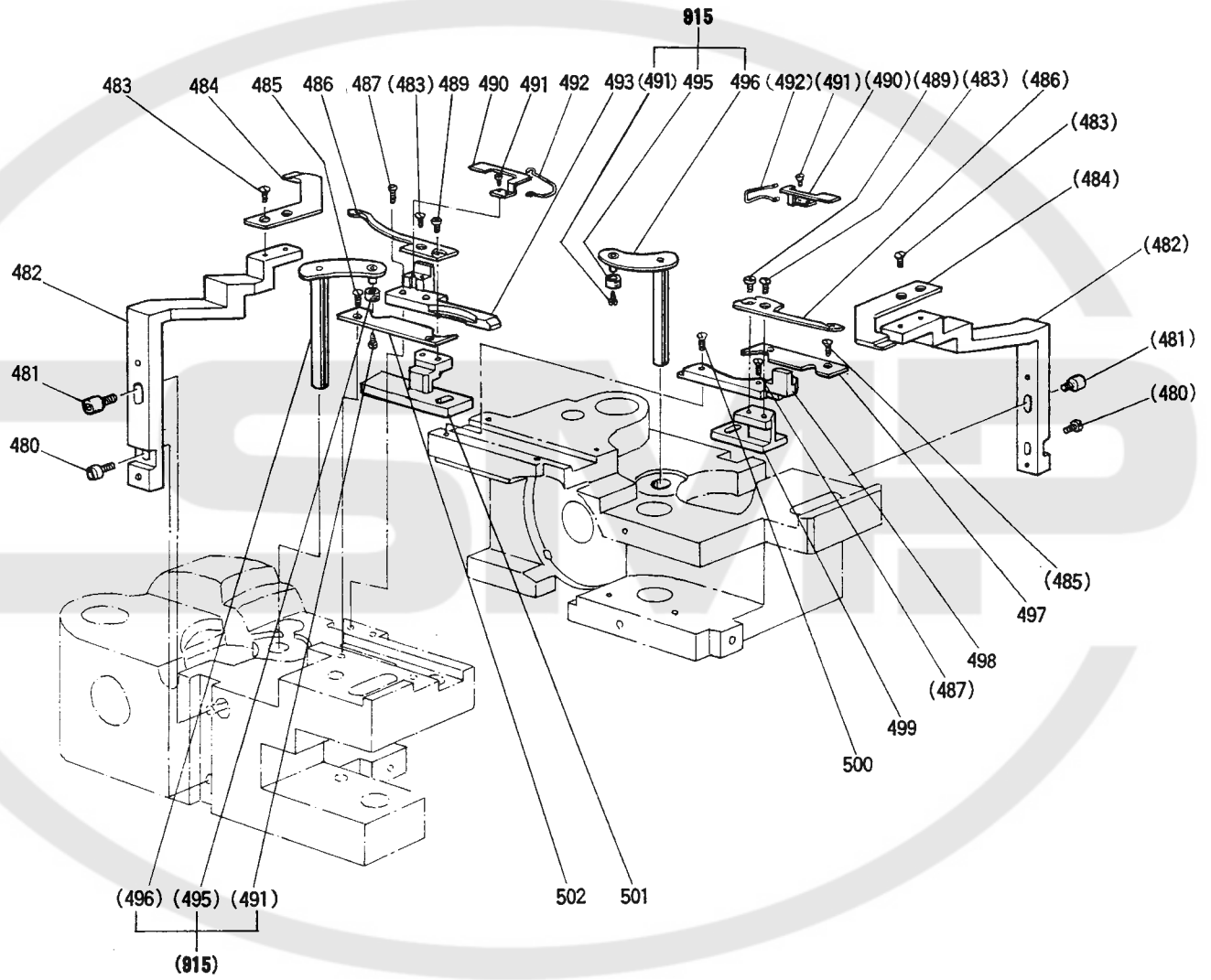

⑨ 糸切り機構 (I)  
KNIFE MECANISM (I)

Fig. No.	部品コード Part No.	部 品 名	Description	使用個数 Amt. Req.					
				LT2-2220			LT2-2230		
				LOB	MOB	BOB	LIT	MITM	BIT
480	M9 0911 030	特殊ネジ	$9/64(40) \times 7$ ..... Screw $9/64(40) \times 7$ .....				2	2	2
481	M9 1106 022	六角穴付ボルト	..... Bolt .....				2	2	2
482	MN 50A0 839	メス取付台	..... Trimming knife holder .....				2	2	2
483	M9 1102 010	皿ネジ	$9/64(40) \times 5$ ..... Screw $9/64(40) \times 5$ .....				6	6	6
484	MP 41A0 838	皿固定メ	..... Fixed blade .....				2	2	2
485	M9 0916 011	皿ネジ	$9/64(40) \times 4$ ..... Screw $9/64(40) \times 4$ .....				4	4	4
486	MP 41B0 838	移動メ	..... Moved knife .....				2	2	2
487	M9 0801 010	皿ネジ	$1/8(40) \times 9.2$ ..... Screw $1/8(40) \times 9.2$ .....				2	2	2
489	M9 0944 002	皿ネジ	$9/64(40) \times 4.5$ ..... Screw $9/64(40) \times 4.5$ .....				2	2	2
490	MN 50A0 192	板バネ	..... Spring plate .....				2	2	2
491	M9 0605 002	皿ネジ	$3/32(56) \times 3.8$ ..... Screw $3/32(56) \times 3.8$ .....				6	6	6
492	MN 50A0 507	センサクバネ	..... Reversing spring .....				2	2	2
493	MN 60A1 154	案内金 (左)	..... Guide (left) .....				1	1	
	MN 60E1 154	案内金 (左)	..... Guide (left) .....						1
915	MN 60A0 950	レバークミタ	..... Lever complete .....				2	2	2
495	MN 60A0 411	コロ	..... Roller .....				2	2	2
496		レバ	..... Lever .....				2	2	2
497	MN 60A2 742	皿蓋 (右)	..... Cover (right) .....				1	1	1
498	MN 60A2 154	案内金 (右)	..... Guide (right) .....				1	1	
	MN 60E0 154	案内金 (右)	..... Guide (right) .....						1
499	MN 60A0 837	メス台 (右)	..... Knife pad (right) .....				1	1	1
500	M9 0906 010	皿ネジ	$9/64(40) \times 9.5$ ..... Screw $9/64(40) \times 9.5$ .....				1	1	1
501	MN 60A0 836	メス台 (左)	..... Knife pad (left) .....				1	1	1
502	MN 60A1 742	皿蓋 (左)	..... Cover (left) .....				1	1	1

Ⅱ 糸切り機構 Ⅱ  
 KNIFE MECHANISM Ⅱ

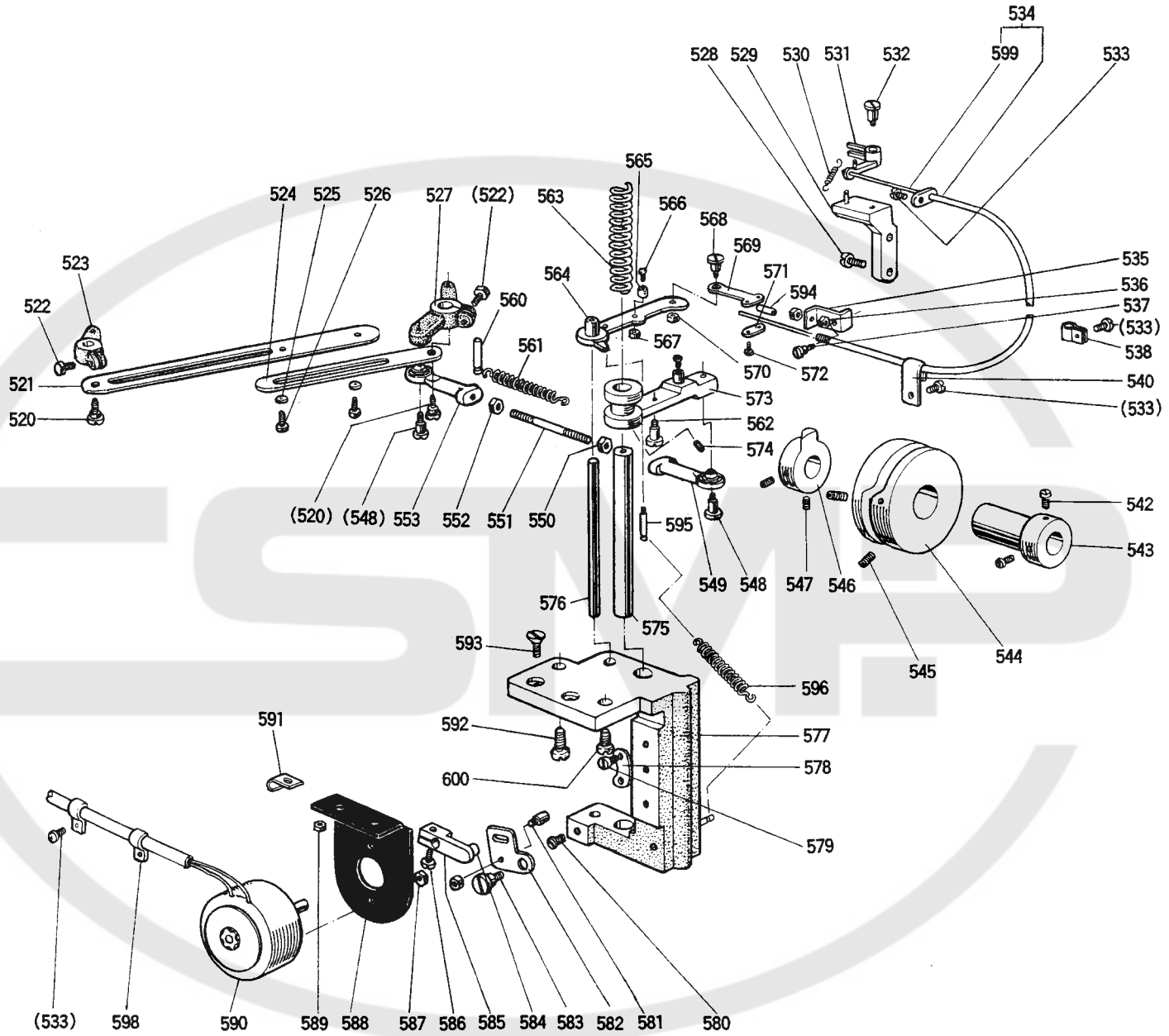

# 10 糸切り機構 (II) KNIFE MECHANISM (II)

Fig. No.	部品コード Part. No.	部 品 名	Description	使用個数 Amt. Req.						
				LT2-2220			LT2-2230			
				LOB	MOB	BOB	L	MTW	BIT	
520	M9 1134 015	平リボ	M5(0.5)×7.5	Screw	2	2	2			
521	MP 43A0 910	リンク	Link		1	1	1			
522	M9 1508 022	ボルト	Bolt		2	2	2			
523	MN 60A3 228	腕	Arm		1	1	1			
524	MN 50A0 910	リ座ボ	Connecting plate		1	1	1			
525	M9 0550 050	ク金	Washer 4.5		2	2	2			
526	M9 1201 022	ボルト	Bolt		2	2	2			
527	MN 60A1 228	腕	Arm		1	1				1
	MN 60A2 228	腕	Arm							1
528	M9 1110 002	平ネジ	<sup>11</sup> / <sub>64</sub> (40)×8	Screw	2	2	2			
529	MN 60A0 172	糸ユルメ	Thread releasing bracket		1	1	1			
530	MN 60A3 572	ツルマキバネ	Spring		1	1	1			
531	MN 60A0 173	糸ユルメ	Thread releasing		1	1	1			
532	M9 1112 015	平ネジ	<sup>11</sup> / <sub>64</sub> (40)×5	Screw	1	1	1			
533	M9 1106 004	ブラマイネジ	<sup>11</sup> / <sub>64</sub> (40)×8	Screw	4	4	4			
534	MN 60E0 746	フレキシブルワイヤ	(組) Flexible wire complete		1	1	1			
535	MN 72A0 601	トリツケイタ	Mounting plate		1	1	1			
536	M9 1373 045	ナット	M5	Nut	2	2	2			
537	M9 1251 015	平ネジ	<sup>3</sup> / <sub>16</sub> (32)×3.5	Screw	1	1	1			
538	MN 60A0 620	ナイロンクリップ	HP-5N	Nylon clip HP-5N	1	1	1			
540	MN 50A0 780	ホルダ	Holder		1	1	1			
542	M9 1516 002	平ネジ	<sup>15</sup> / <sub>64</sub> (28)×8.5	Screw	2	2	2			
543	MN 72A0 750	ブッシュ	Bushing		1	1	1			
544	MN 50A0 350	カム	Cam		1	1	1			
545	M9 1602 020	六角穴付止メネジ	<sup>1</sup> / <sub>4</sub> (40)×9.5	Screw	2	2	2			
546	MN 72A0 350	カム	Cam		1	1	1			
547	M9 1055 020	六角穴付止メネジ	M4×4	Screw	2	2	2			
548	M9 1263 015	平ネジ	M5×8.5	Screw	2	2	2			
549	MN 55A0 975	ロッドエンド	(右) Ball joint		1	1	1			
550	M9 1377 045	ナット	M5	Nut	1	1	1			
551	M9 5004 023	植込ミボルト	Bolt		1	1	1			
552	M9 1374 045	ナット	左M5	Nut M5 (left)	1	1	1			
553	MN 72A0 975	ロッドエンド	(左) Ball joint		1	1	1			
556	M9 5003 067	溝付ピン	BXガタ 5×14	Pin BX-5×14	1	1	1			
561	MN 50A0 572	ツル巻バネ	Spring		1	1	1			
562	M9 1111 015	平ネジ	<sup>11</sup> / <sub>64</sub> (40)×5.5	Screw	1	1	1			
563	MN 60A5 572	ツル巻バネ	Spring		1	1	1			
564	MN 60E0 950	糸ユルメレバー	組立	Thread releasing lever complete	1	1	1			
565	MN 50A0 411	コ	Roller		1	1	1			
566	M9 1131 015	平ネジ	<sup>11</sup> / <sub>64</sub> (40)×3.6	Screw	1	1	1			
567	M9 1107 045	ナット	<sup>11</sup> / <sub>64</sub> (40)	Nut	1	1	1			
568	M9 1231 015	平ネジ	<sup>3</sup> / <sub>16</sub> (28)×5	Screw	1	1	1			
569	MN 72A1 601	取付板	Mounting plate		1	1	1			
570	M9 1201 045	ナット	<sup>3</sup> / <sub>16</sub> (28)	Nut <sup>3</sup> / <sub>16</sub> (28)	1	1	1			
571	MF 36A0 750	ブッシュ	Bushing		1	1	1			
572	M9 0802 002	平ネジ	<sup>1</sup> / <sub>8</sub> (44)×7	Screw	2	2	2			
573	MN 60A0 886	揺動腕	(組) Vibrating crank complete		1	1	1			
574	M9 1001 020	六角穴付止メネジ	<sup>11</sup> / <sub>64</sub> (40)×5	Screw	2	2	2			
575	MN 50A3 454	軸	Shaft		1	1	1			
576	MN 60A0 454	軸	Shaft		1	1	1			
577	MN 60A0 603	取付台	Mounting base		1	1	1			
578	MN 50A0 477	ストップ	Stopper		1	1	1			
579	M9 1109 002	平ネジ	<sup>11</sup> / <sub>64</sub> (40)×7	Screw	2	2	2			
580	M9 1102 002	平ネジ	<sup>11</sup> / <sub>64</sub> (40)×8.5	Screw	1	1	1			
581	M9 1111 033	ピンネジ	<sup>11</sup> / <sub>64</sub> (40)×5	Pin screw <sup>11</sup> / <sub>64</sub> (40)×5	1	1	1			
582	MN 50A3 950	レバー	Lever		1	1	1			
583	M9 1103 016	丸平ネジ	<sup>11</sup> / <sub>64</sub> (40)×3.5	Screw	1	1	1			
584	M9 0615 063	段付ピン	Pin		1	1	1			
585	MN 50A4 228	腕	Arm		1	1	1			
586	M9 1112 002	平ネジ	<sup>11</sup> / <sub>64</sub> (40)×12	Screw	1	1	1			
587	M9 1105 045	ナット	<sup>11</sup> / <sub>64</sub> (40)	Nut <sup>11</sup> / <sub>64</sub> (40)	1	1	1			
588	MN 50A3 601	取付板	Set plate		1	1	1			
589	M9 1373 045	ナット	M5	Nut	2	2	2			
590	M9 1002 095	ソレノイド	(組立) Solenoid complete		1	1	1			
591	MN 50A0 780	ホルダ	Holder		1	1	1			
592	M9 1603 003	丸平ネジ	<sup>1</sup> / <sub>4</sub> (24)×16	Screw	1	1	1			
593	M9 5001 037	Pサラネジ	M5×16	Screw M5×16	2	2	2			
594	MN 72A1 750	ブッシュ	Bushing		1	1	1			
595	M9 1111 030	特殊ネジ	<sup>11</sup> / <sub>64</sub> (40)×4	Screw	1	1	1			
596	MN 50A3 572	ツル巻バネ	Spring		1	1	1			
598	MF 10A0 689	ホルダ	Holder		2	2	2			
599	MN 72A0 746	フレキシブルワイヤ	Flexible wire		1	1	1			
600	M9 1602 003	丸平ネジ	<sup>1</sup> / <sub>4</sub> (24)×13	Screw	1	1	1			

① タッチバックおよび検出器機構  
 TOUCH BACK, COMPENSATION STITCHING &  
 DETECTOR MECHANISM

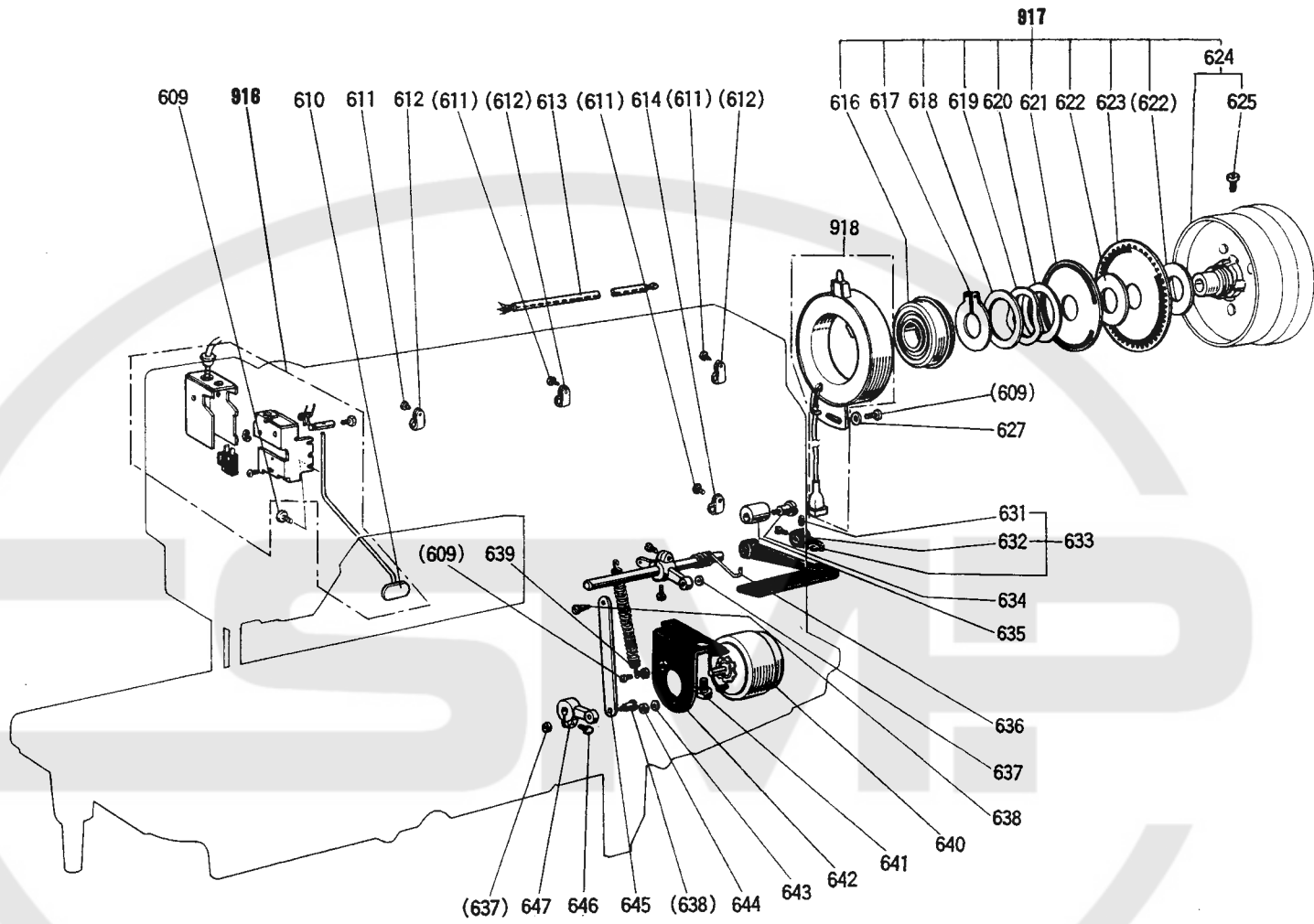

① タッチバックおよび検出器機構  
TOUCH BACK, COMPENSATION STITCHING &  
DETECTOR MECHANISM

Fig. No.	部品コード Part. No.	部 品 名	Description	使用個数 Amt. Req.					
				LT2-2220			LT2-2230		
				LOB	MOB	BOB	LT	MTW	BIT
609	M9 1106 004	ブラマイネジ	$11/64(40) \times 8$ .....				5	5	5
918	MN 72E0 534	タッチスイッチ	(組立) .....				1	1	1
610	MN 72E0 950	レバ	(組立) .....				1	1	1
611	M9 1112 004	ブラマイネジ	$11/64(40) \times 11$ .....				4	4	4
612	M9 4003 099	コードホルダ	.....				3		3
	MN 60A0 620	コードホルダ	.....					3	
613	M9 7003 095	アース線	(組立) .....				1	1	1
614	M9 4008 099	コードホルダ	.....				1	1	1
917	MN 72E0 682	プーリ	(組立) .....				1	1	1
616	MN 70A0 456	軸受	.....				1	1	1
617	M9 0330 065	C形止メ輪	30 .....				1	1	1
618	M9 3001 050	座金	.....				1	1	1
619	MF 01A0 259	反射板押エスプリング	.....				1	1	1
620	MF 01A1 476	スペーサ	B .....				1	1	1
621	MN 72A1 694	反射板	F20 (上) .....				1	1	1
622	MF 01A0 476	スペーサ	A .....				2	2	2
623	MN 72A0 694	反射板	F10 (下) .....				1	1	1
624	MN 72E1 682	プーリ	(組立) .....				1	1	1
625	M9 1520 002	平ネジ	$15/64(28) \times 12$ .....				2	2	2
627	M9 3002 050	座金	.....				1	1	1
918	MF 01E0 406	検出器	(組立) .....				1	1	1
631	M9 1506 001	止メネジ	$15/64(28) \times 7$ .....				1	1	1
632	M9 1519 002	平ネジ	$15/64(28) \times 7.5$ .....				1	1	1
633	MN 72A1 950	レバ	(組立) .....				1	1	1
634	M9 1516 015	平ネジ	段付 $15/64(28) \times 6$ .....				1	1	1
635	MN 50A0 417	ゴム	ワ $\phi 16$ .....				1	1	1
636	MN 50A0 729	ヒネ	リット .....				1	1	1
637	M9 1502 045	ナット	$15/64(28)$ .....				2	2	2
638	M9 1517 015	平ネジ	段付 $15/64(28) \times 14$ .....				2	2	2
639	M9 1105 045	ナット	$11/64(40)$ .....				1	1	1
640	M9 1001 095	ソレノイド	(組立) .....				1	1	1
641	M9 8005 022	ボルト	M8×12 .....				1	1	1
642	MN 50A2 601	取付板	.....				1	1	1
643	M9 0601 053	バネ座金	6 .....				2	2	2
644	M9 1571 045	ナット	M6 .....				2	2	2
645	MN 50A2 910	リンク	.....				1	1	1
646	M9 1502 022	ボルト	$15/64(28) \times 13$ .....				1	1	1
647	MN 50A5 228	腕	.....				1	1	1

12 ワイパー機構  
WIPER MECHANISM

919

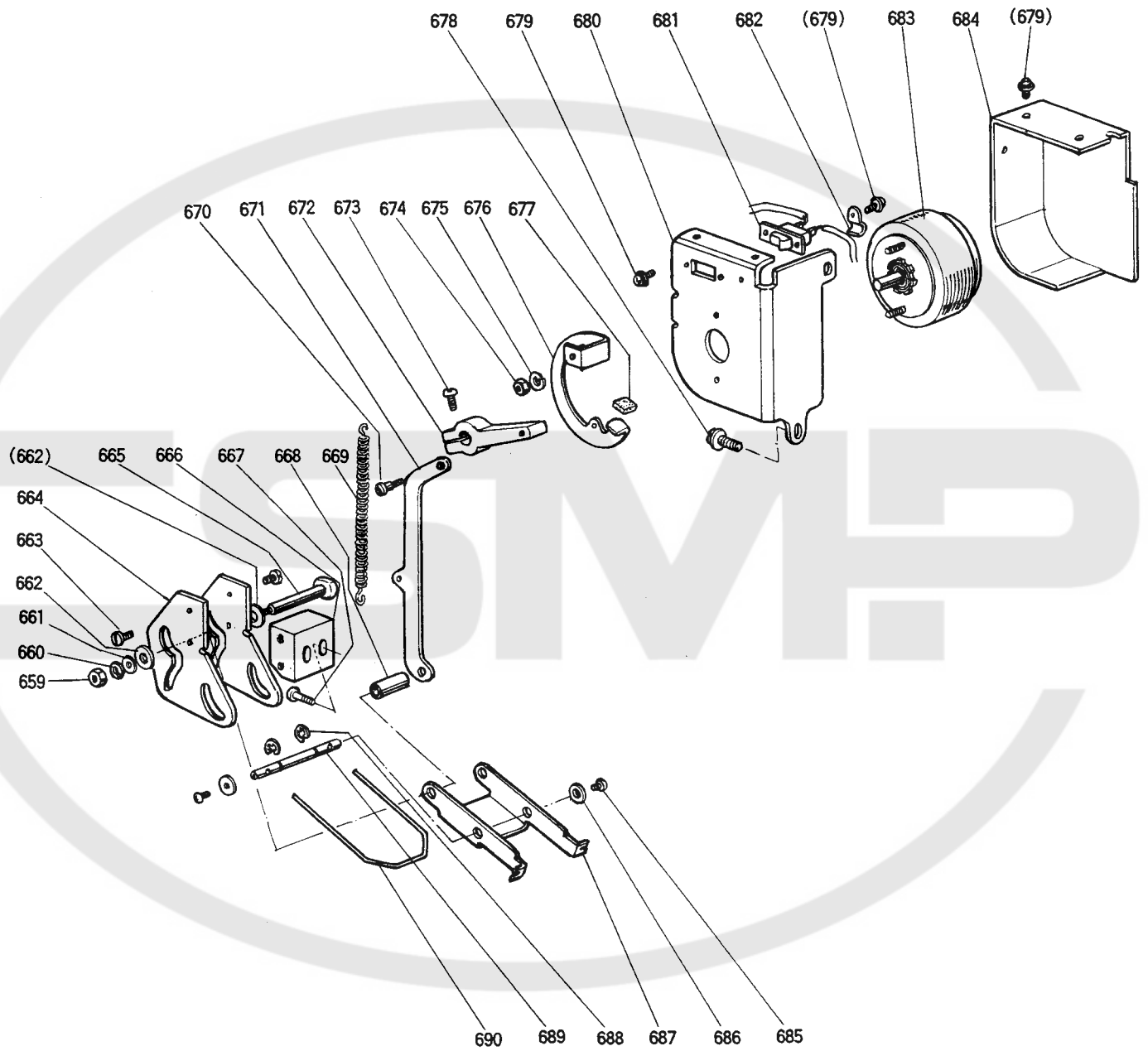



# 12 ワイパー機構 WIPER MECHANISM

Fig. No.	部品コード Part No.	部 品 名	Description	使用個数 Amt. Req.					
				LT2-2220			LT2-2230		
				LOB	MOB	BOB	LIT	MITV	BIT
918	MN 72E0 984	ワイパー機構部分	Wiper mechanism						1
659	M9 0872 045	ナット	Nut M3						1
660	M9 0301 053	バネ座金	Spring washer 3						1
661	M9 0312 050	座金	Washer 3						1
662	M9 0403 050	座金	Washer 4						2
663	M9 1109 002	平ネジ	Screw 11/64(40)×7						4
664	MN 72E0 327	カム板(組)	Cam plate (complete)						1
665	MN 72A0 454	ツバ付軸	Shaft M3×3.5						1
666	MN 72A0 982	ワイパー台	Wiper stand						1
667	M9 1106 003	丸平ネジ	Screw 11/64(40)×20						2
668	MN 72A0 352	カラ	Collar						1
669	MN 50A2 572	ツル巻バネ	Spring						1
670	M9 0929 015	平ネジ	Screw 9/64(40)×7.4						1
671	MN 72A0 910	リンク	Link						1
672	MN 72A0 981	ワイパー腕	Wiper crank						1
673	M9 1117 002	丸平ネジ	Screw 11/64(40)×11.4						1
674	M9 1003 045	ナット	Nut M4						2
675	M9 0401 053	バネ座金	Spring washer 4						2
676	MN 72A0 477	ストップ板	Stopper plate						1
677	MN 72A0 397	クッション	Cushion						1
678	M9 1109 004	座金付ブラマイネジ	Screw 11/64(40)×8.2						2
679	M9 0863 004	座金付ブラマイネジ	Screw M3×6						6
680	MN 72A2 601	ソレノイド取付板	Solenoid plate						1
681	MF 40E2 484	波動スイッチ	Switch						1
682	MF 00A1 780	コードホルダ	Cord holder						1
683	M9 1010 095	ロータリソレノイド	Rotary solenoid						1
684	MN 72A0 339	カバー	Cover						1
685	M9 0806 002	平ネジ	Screw 1/8(44)×6						2
686	M9 1571 045	小座金	Washer 6						2
687	MN 72A0 470	ワイパースベリ板	Wiper slide plate						1
688	M9 0704 065	E形止め輪	E-type stop ring 4						2
689	MN 72A1 454	ワイパー軸	Wiper shaft						1
690	MN 72A0 980	ワイパー	Wiper						1

13 給油機構  
OIL LUBRICATION MECHANISM

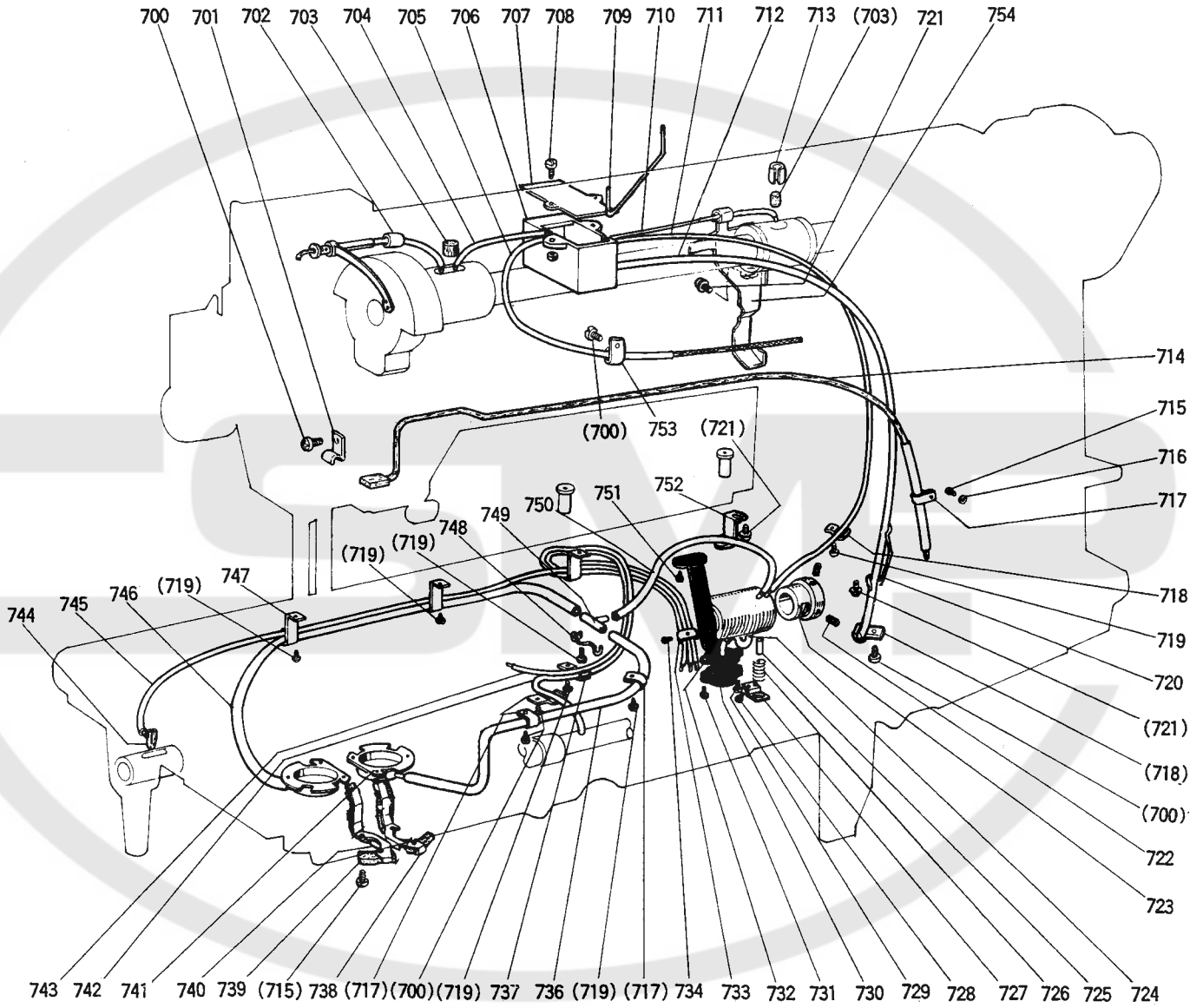

13 給油機構

OIL LUBRICATION MECHANISM

Fig. No.	部品コード Part No.	部 品 名	Description	使用個数 Amt. Req.					
				LT2-2220			LT2-2230		
				LOB	MOB	BOB	LIT	MITW	BIT
700	M9 1106 004	ブラマイネジ	9/64(40)×8	3	3	3	3	3	3
701	MF 70A0 689	ホルダ	Holder	1	1	1	1	1	1
702	MN 70A0 688	パイプ	Pipe	1	1	1	1	1	1
703	MP 40A3 740	フェルト	Felt	2	2	1	2	2	1
704	MN 70E0 688	パイプヒモ (組)	Oil pipe & wick complete	1	1	1	1	1	1
705	MN 70E1 688	パイプヒモ (組)	Oil pipe & wick complete	1	1	1	1	1	1
706	MN 70E0 138	オイルタンク (組)	Oil tank complete	1	1	1	1	1	1
707	MN 70A0 691	ガスケット	Gasket	1	1	1	1	1	1
708	M9 1402 010	P黄銅サラネジ	M4×16	2	2	2	2	2	2
709	MN 70A0 780	ホルダ	Holder	1	1	1	1	1	1
710	MN 70E2 688	パイプヒモ (組)	Oil pipe & wick complete	1	1		1	1	
711	MN 70E7 688	パイプ	3D×1×500	1	1	1	1	1	1
712	MN 70E8 688	パイプ	5D×1×360	1	1	1	1	1	1
713	MN 70A2 688	パイプ	Pipe	1	1		1	1	
714	MN 70E3 688	パイプ・フェルト (組)	Pipe & felt complete	1	1	1	1	1	1
715	M9 0903 002	平ネジ	9/64(40)×6.5	7	7	7	7	7	7
716	M9 0304 053	バネ座金	3.5	1	1	1	1	1	1
717	MF 10A0 689	ホルダ	Holder	4	4	4	4	4	4
718	MN 70A1 780	ホルダ	Holder	2	2	2	2	2	2
719	M9 1107 002	平ネジ	11/64(40)×5.5	7	7	7	6	6	6
720	MN 70A2 780	ホルダ	Holder	1	1	1	1	1	1
721	M9 1109 004	座金付ブラマイネジ	11/64(40)×9	3	3	3	3	3	3
722	M9 1111 001	止メネジ	11/64(40)×10	2	2	2	2	2	2
723	MN 40A0 750	ブッシュ	Bushing	1	1	1	1	1	1
724	MN 70E7 688	パイプ	3D×1×90	1	1	1	1	1	1
725	M9 5007 063	特殊ピン	Pin	1	1	1	1	1	1
726	MN 40A1 572	ツル巻バネ	Spring	1	1	1	1	1	1
727	MN 40A0 705	バネ押エ	Spring holder	1	1	1	1	1	1
728	M9 0805 002	平ネジ	1/8(44)×4.5	1	1	1	1	1	1
729	M9 0908 003	丸平ネジ	9/64(40)×5	1	1	1	1	1	1
730	MN 40E0 337	フィルター	Filter	1	1	1	1	1	1
731	M9 0905 003	丸平ネジ	9/64(40)×7	1	1	1	1	1	1
732	MN 70E1 601	取付板 (組)	Base plate complete	1	1	1	1	1	1
733	MP 40A4 689	ホルダ	Holder	1	1	1	1	1	1
734	M9 0906 002	平ネジ	9/64(40)×4.5	1	1	1	1	1	1
736	MN 70E7 688	パイプ	3D×1×325	1	1	1	1	1	1
737	MQ 60A2 780	ホルダ	Holder	1	1	1	1	1	1
738	MN 70A3 780	ホルダ	Holder (right)	1	1	1	1	1	1
739	MN 70A2 740	フェルト	Felt	2	2	2	2	2	2
740	MN 70A4 780	ホルダ	Holder (left)	1	1	1	1	1	1
741	MN 50E0 742	フタ (組)	Cover complete	2	2	2	2	2	2
742	MN 70E4 688	パイプヒモ (組)	Oil pipe & wick complete	1	1	1	1	1	1
743	MN 70E5 688	パイプヒモ (組)	Oil pipe & wick complete	1	1	1	1	1	1
744	MN 70E0 148	ヒモ	φ2.5×35	3	3	3	3	3	3
745	MN 70E6 688	パイプヒモ (組)	Oil pipe & wick complete	1	1	1	1	1	1
746	MN 70E7 688	パイプ	3D×1×480	1	1	1	1	1	1
747	MN 70A5 780	ホルダ	Holder	3	3	3	2	2	2
748	MN 70A6 780	ホルダ	Holder	1	1	1	1	1	1
749	MP 40A0 571	油ツギ	Oil pipe connector	1	1	1	1	1	1
750	MN 70E7 688	パイプ	3D×1×50	1	1	1	1	1	1
751	MP 1118 002	平ネジ	11/64(40)×10	2	2	2	2	2	2
752	MN 70A0 429	支エ板	Holding plate	1	1	1	1	1	1
753	MF 40A1 780	ホルダ	Holder	1	1	1	1	1	1
754	MN 70A7 780	ホルダ	Holder	1	1	1	1	1	1



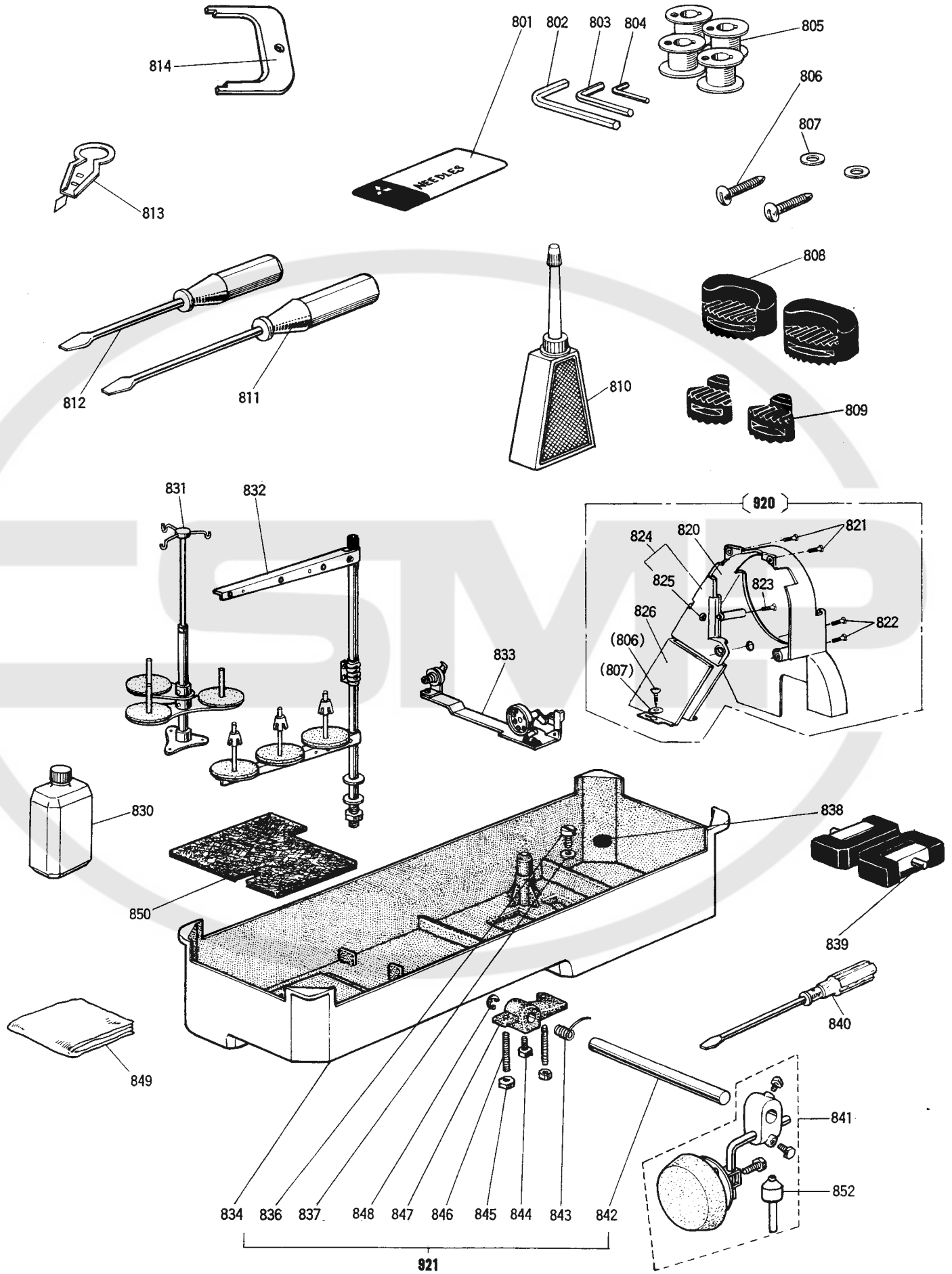







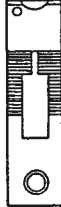



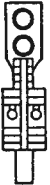

14 付属品  
ACCESSORIES



14 付属品  
ACCESSORIES

Fig. No.	部品コード Part. No.	部 品 名	Description	使用個数 Amt. Req.					
				LT2-2220			LT2-2230		
				LOB	MOB	BOB	LIT	MFTW	BIT
801	MN 68A0 128	ミ シ ン 針	DPX5 #11	6			6		
	MV 01A0 128	ミ シ ン 針	DPX5 #14		6			6	
	MN 42A0 128	ミ シ ン 針	DPX5 #21			6			6
802	MS 02A2 976	六角棒スバナ	3				1	1	1
803	MS 02A1 976	六角棒スバナ	2.5				1	1	1
804	MS 02A0 976	六角棒スバナ	2				1	1	1
805	MN 40A0 123	ボビ	Bobbin	4	4				
	MN 12B0 123	ボビ	Bobbin			4			
	MN 72A0 123	ボビ	Bobbin				4	4	
	MN 74A0 123	ボビ	Bobbin						4
806	M9 0403 041	丸木ネジ	4.5×20	4	4	4	4	4	4
807	M9 0550 050	ガキ座金	5	4	4	4	4	4	4
808	MN 70A0 419	防振ゴム		2	2	2	2	2	2
809	MN 70A1 419	防振ゴム		2	2	2	2	2	2
810	MF 60A0 137	油 差 シ	Oiler	1	1	1	1	1	1
811	MB 02A0 608	ネ ジ 回 シ	(中) Screw driver (middle)	1	1	1	1	1	1
812	MB 02A1 608	ネ ジ 回 シ	(小) Screw driver (small)	1	1	1	1	1	1
813	MN 10A0 172	糸 通 シ	(組) Thread a needle kit	1	1	1	1	1	1
814	MF 01A0 565	反 射 板 調 整 具	Adjusting plate for speed command disc				1	1	1
920	MN 70E0 776	ベルトカバー	(組)(国内のみ) Belt complete (Domestic only)	1	1	1			
	MN 72E0 776	ベルトカバー	(組)(国内のみ) Belt complete (Domestic only)				1	1	1
820	MF 01A0 776	ベルトカバー	1 Belt cover 1	1	1	1	1	1	1
821	M9 1109 004	PW付ブラマイネジ	<sup>11</sup> / <sub>64</sub> (40)×8	2	2	2	2	2	2
822	M9 1506 004	ブラマイネジ	<sup>15</sup> / <sub>64</sub> (28)×8	2	2	2	2	2	2
823	M9 0410 037	P ナベネジ	M4×8	1	1	1	1	1	1
824	MF 01E1 776	ベルトカバー	2 (組) Belt cover 2 (complete)	1	1	1	1	1	1
825	M9 1003 045	ナ ッ ト	M4	1	1	1	1	1	1
826	MF 01A1 776	ベルトカバー	3 Belt cover 3	1	1	1			
	MN 72A0 776	ベルトカバー	3 Belt cover 3				1	1	1
830	MN 70E0 149	油 缶	Oil can	1	1	1	1	1	1
831	MN 10E0 193	糸 立 装 置	3本立(組)(海外用) Cotton stand (Export only)	1	1	1			
832	MN 50E0 193	糸 立 装 置	3本立(組)(国内用) Cotton Stand (Domestic)	1	1	1			
	MN 50E0 193	糸 立 装 置	3本立(組) Cotton Stand				1	1	1
833	MN 70E0 190	糸 巻 仕 掛	(組) Bobbin winder	1	1		1	1	
	MN 69E0 190	糸 巻 仕 掛	(組) Bobbin winder			1			1
834	MP 40A0 139	油 槽	Oil reservoir	1	1	1	1	1	1
836	M9 2002 002	平 ね じ	<sup>5</sup> / <sub>16</sub> (28)×8.2	1	1	1	1	1	1
837	M9 7001 052	特 殊 座 金	14 Washer 14	1	1	1	1	1	1
838	M9 0701 099	O P - S 磁 石		1	1	1	1	1	1
839	MF 01E0 418	蝶	(組) Hinge complete	2	2	2	2	2	2
840	MF 00A0 608	ネ ジ 回 シ	(大) Screw driver (large)	1	1	1	1	1	1
841	MN 40E0 727	小 物 部 品	(組) Small parts	1	1	1	1	1	1
842	MF 20A1 723	膝 上 ゲ 軸	Knee lifter shaft	1	1	1	1	1	1
843	MF 20A1 729	ネ リ バ ネ ト	Spring	1	1	1	1	1	1
844	M9 2001 031	特 殊 ボ ル ト	Bolt	1	1	1	1	1	1
845	M9 1506 045	ナ ッ ト	<sup>15</sup> / <sub>64</sub> (28)	2	2	2	2	2	2
846	M9 1520 001	止 メ ネ ジ	<sup>15</sup> / <sub>64</sub> (28)×27	2	2	2	2	2	2
847	MN 70A0 724	膝 上 ゲ 腕	Knee lifter crank	1	1	1	1	1	1
848	M9 0515 065	E 形 止 メ 輪	9	1	1	1	1	1	1
849	MF 60A0 734	ビ ニール カバ ー	Vinyl cover	1	1	1	1	1	1
850	MN 70A0 740	フ ェ ル ト	Felt	1	1	1	1	1	1
852	MN 40A0 578	膝 上 ゲ ビ ン	Knee lifter pin	1	1	1	1	1	1
921	MN 70E0 139	油 槽	(組) Oil reservoir complete	1	1	1	1	1	1

15 ゲージ部品表(I) LT2-2220  
GAUGE PARTS LIST (I)

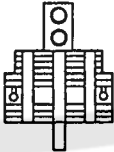
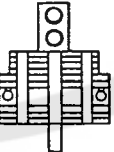
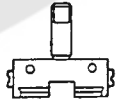









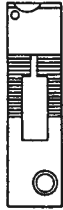





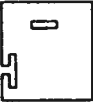

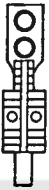
針板 Needle Plate			送り Feed Dog			押工 Presser Foot	針ダキ Needle Clamp	スベリ板 (左) Slide Plate (L)	スベリ板 (右) Slide Plate (R)
LOB	MOB	BOB	LOB	MOB	BOB				
 $3/32 \sim 5/32$			 針穴φ1.6 歯ピッチ 1.15 $3/32 \sim 5/32$	 針穴φ1.9 歯ピッチ 1.7 $3/32 \sim 5/32$	 針穴φ2.5 歯ピッチ 1.7 $3/32 \sim 5/32$				
 $3/16 \sim 3/8$			 針穴φ1.6 歯ピッチ 1.15 $3/16 \sim 3/8$	 針穴φ1.9 歯ピッチ 1.7 $3/16 \sim 3/8$	 針穴φ2.5 歯ピッチ 1.7 $3/16 \sim 3/8$	 LOB $3/32 \sim 3/8$ MOB $3/32 \sim 1 1/2$	 $3/32 \sim 5/8$		
	 $1/2 \sim 3/4$			 針穴φ1.9 歯ピッチ 1.7 $1/2 \sim 3/4$	 針穴φ2.5 歯ピッチ 1.7 $1/2 \sim 3/4$	 BOB $3/32 \sim 1 1/2$		 $3/32 \sim 1 1/2$	 $3/32 \sim 1 1/2$
	 $1/2 \sim 1 1/2$			 針穴φ1.9 歯ピッチ 1.7 $1/2 \sim 1 1/2$	 針穴φ2.5 歯ピッチ 1.7 $1/2 \sim 1 1/2$		 $3/4 \sim 1 1/2$		

15 ゲージ部品表(I) LT2-2220  
GAUGE PARTS LIST (I)

部品コード Parts No.

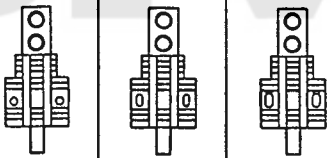
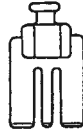
針巾寸法 Gauge Size	針板 Needle Plate	送り Feed Dog	押工 Presser Foot	針ダキ Needle Clamp	スベリ板(左) Slide Plate (L)	スベリ板(右) Slide Plate (R)
<b>TYPE LOB</b>						
3/32(2.4 <sup>m</sup> /m)	MN10J3101	MN70J1104	MN10J3105	MN57J2102	MN70A1473	MN70A1474
1/8(3.2 <sup>m</sup> /m)	MN10J4101	MN70J2104	MN10J4105	MN57J3102	MN70A1473	MN70A1474
5/32(4 <sup>m</sup> /m)	MN10J5101	MN70J3104	MN10J5105	MN57J4102	MN70A1473	MN70A1474
3/16(4.8 <sup>m</sup> /m)	MN10J6101	MN70J4104	MN10J6105	MN57J5102	MN70A1473	MN70A1474
7/32(5.6 <sup>m</sup> /m)	MN10J7101	MN70J5104	MN10J7105	MN57J6102	MN70A1473	MN70A1474
1/4(6.4 <sup>m</sup> /m)	MN10J8101	MN70J6104	MN10J8105	MN57J7102	MN70A1473	MN70A1474
9/32(7.1 <sup>m</sup> /m)	MN70J1101	MN70J7104	MN70J1105	MN57J8102	MN70A1473	MN70A1474
5/16(8 <sup>m</sup> /m)	MN10J9101	MN70J8104	MN10J9105	MN57J9102	MN70A2473	MN70A1474
3/8(9.5 <sup>m</sup> /m)	MN10K1101	MN70J9104	MN10K1105	MN57K1102	MN70A2473	MN70A1474
<b>TYPE MOB</b>						
3/32(2.4 <sup>m</sup> /m)	MN10J3101	MN10J3104	MN10J3105	MN57J2102	MN70A1473	MN70A1474
1/8(3.2 <sup>m</sup> /m)	MN10J4101	MN10J4104	MN10J4105	MN57J3102	MN70A1473	MN70A1474
5/32(4 <sup>m</sup> /m)	MN10J5101	MN10J5104	MN10J5105	MN57J4102	MN70A1473	MN70A1474
3/16(4.8 <sup>m</sup> /m)	MN10J6101	MN10J6104	MN10J6105	MN57J5102	MN70A1473	MN70A1474
7/32(5.6 <sup>m</sup> /m)	MN10J7101	MN10J7104	MN10J7105	MN57J6102	MN70A1473	MN70A1474
1/4(6.4 <sup>m</sup> /m)	MN10J8101	MN10J8104	MN10J8105	MN57J7102	MN70A1473	MN70A1474
5/16(8 <sup>m</sup> /m)	MN10J9101	MN10J9104	MN10J9105	MN57J9102	MN70A2473	MN70A1474
3/8(9.5 <sup>m</sup> /m)	MN10K1101	MN10K1104	MN10K1105	MN57K1102	MN70A2473	MN70A1474
1/2(12.7 <sup>m</sup> /m)	MN10K3101	MN10K3104	MN10K3105	MN57K3102	MN70A3473	MN70A1474
5/8(16 <sup>m</sup> /m)	MN10K4101	MN10K4104	MN10K4105	MN57K5102	MN70A3473	MN70A1474
3/4(19.1 <sup>m</sup> /m)	MN10K5101	MN10K5104	MN10K5105	MN57K6102	MN70A4473	MN70A2474
1(25.4 <sup>m</sup> /m)	MN10K6101	MN10K6104	MN10K6105	MN57K8102	MN70A5473	MN70A2474
1 <sup>1</sup> / <sub>8</sub> (28.5 <sup>m</sup> /m)	MN10K7101	MN10K7104	MN10K7105	MN57K9102	MN70A6473	MN70A2474
1 <sup>1</sup> / <sub>4</sub> (31.8 <sup>m</sup> /m)	MN10K8101	MN10K8104	MN10K8105	MN58K1102	MN70A6473	MN70A2474
1 <sup>1</sup> / <sub>2</sub> (38.1 <sup>m</sup> /m)	MN10K9101	MN10K9104	MN10K9105	MN58K3102	MN70A7473	MN70A2474
<b>TYPE BOB</b>						
3/32(2.4 <sup>m</sup> /m)	MN42J3101	MN10J3104	MN52J3105	MN57J2102	MN70A1473	MN70A1474
1/8(3.2 <sup>m</sup> /m)	MN26J4101	MN12J4104	MN12J4105	MN57J3102	MN70A1473	MN70A1474
5/32(4 <sup>m</sup> /m)	MN42J5101	MN12J5104	MN52J5105	MN57J4102	MN70A1473	MN70A1474
3/16(4.8 <sup>m</sup> /m)	MN26J6101	MN26J6104	MN26J6105	MN57J5102	MN70A1473	MN70A1474
7/32(5.6 <sup>m</sup> /m)	MN42J7101	MN12J7104	MN52J7105	MN57J6102	MN70A1473	MN70A1474
1/4(6.4 <sup>m</sup> /m)	MN26J8101	MN26J8104	MN26J8105	MN57J7102	MN70A1473	MN70A1474
5/16(8 <sup>m</sup> /m)	MN26J9101	MN26J9104	MN26J9105	MN57J9102	MN70A2473	MN70A1474
3/8(9.5 <sup>m</sup> /m)	MN26K1101	MN26K1104	MN26K1105	MN57K1102	MN70A2473	MN70A1474
1/2(12.7 <sup>m</sup> /m)	MN26K3101	MN12K3104	MN26K3105	MN57K3102	MN70A3473	MN70A1474
5/8(16 <sup>m</sup> /m)	MN42K4101	MN12K4104	MN52K4105	MN57K5102	MN70A3473	MN70A1474
3/4(19.1 <sup>m</sup> /m)	MN42K5101	MN12K5104	MN52K5105	MN57K6102	MN70A4473	MN70A2474
1(25.4 <sup>m</sup> /m)	MN42K6101	MN12K6104	MN52K6105	MN57K8102	MN70A5473	MN70A2474
1 <sup>1</sup> / <sub>8</sub> (28.5 <sup>m</sup> /m)	MN42K7101	MN12K7104	MN52K7105	MN57K9102	MN70A6473	MN70A2474
1 <sup>1</sup> / <sub>4</sub> (31.8 <sup>m</sup> /m)	MN42K8101	MN12K8104	MN52K8105	MN58K1102	MN70A6473	MN70A2474
1 <sup>1</sup> / <sub>2</sub> (38.1 <sup>m</sup> /m)	MN70J2101	MN70K1104	MN70J2105	MN58K3102	MN70A7473	MN70A2474

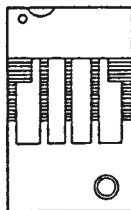
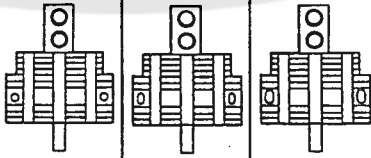
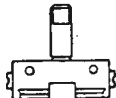
16 ゲージ部品表(II) LT2-2230  
GAUGE PARTS LIST (II)

針板 Needle Plate			送り Feed Dog				押工 Presser Foot	針ダキ Needle Clamp	スベリ板 (左) Slide Plate (L)	スベリ板 (右) Slide Plate (R)
L1T	MITW	BIT	L1T	MITW	MITW (デニム用 Denim)	BIT				
 $3/32 \sim 5/32$			 針穴 $\phi 1.6$ 歯ピッチ 1.15 $3/32 \sim 5/32$	 針穴 $\phi 1.8$ 歯ピッチ 1.7 $3/32 \sim 5/32$	 針穴 $1.8 \times 2.8$ 歯ピッチ 1.7 $3/32 \sim 5/32$	 針穴 $2 \times 3.2$ 歯ピッチ 1.7 $3/32 \sim 5/32$			 $3/32 \sim 1 1/2$	 $3/32 \sim 1 1/2$
 $3/16 \sim 3/8$			 針穴 $\phi 1.6$ 歯ピッチ 1.15 $3/16 \sim 3/8$	 針穴 $\phi 1.8$ 歯ピッチ 1.7 $3/16 \sim 3/8$	 針穴 $1.8 \times 2.8$ 歯ピッチ 1.7 $3/16 \sim 3/8$	 針穴 $2.2 \times 3.2$ 歯ピッチ 1.7 $3/16 \sim 3/8$	 L1T $3/32 \sim 3/16$ MITW $3/32 \sim 1 1/2$	 $3/32 \sim 5/8$		
 $1/2 \sim 3/4$			 針穴 $\phi 1.8$ 歯ピッチ 1.7 $1/2 \sim 3/4$				 BIT $3/32 \sim 1 1/2$		Fig. 551 植え込みボルト Connecting Bolt  $3/32 \sim 5/8$ M95004023 $3/4 \sim 1 1/2$ M95006023	
 $1 \sim 1 1/2$			 針穴 $\phi 1.8$ 歯ピッチ 1.7 $1 \sim 1 1/2$					 $3/4 \sim 1 1/2$	Fig. 690 ワイパー Wiper  $3/32 \sim 1/2$ MN72A0980 $5/8 \sim 3/4$ MN72A1980 $1 \sim 1 1/8$ MN72A2980 $1 1/4 \sim 1 1/2$ MN72A3980	



16 ゲージ部品表(II) LT2-2230  
GAUGE PARTS LIST (II)

部品コード Parts No.

針巾寸法 Gauge Size	針板 Needle Plate	送り Feed Dog	送り(デニム) Feed Dog (for Denim)	押工 Presser Foot	針ダキ Needle Clamp	スベリ板(左) Slide Plate (L)	スベリ板(右) Slide Plate (R)
TYPE LIT							
3/32(2.4 <sup>m</sup> /m)	MN50J3101	MN72J1104		MN10J3105	MN57J2102	MN72A1473	MN72A1474
1/8(3.2 <sup>m</sup> /m)	MN50J4101	MN72J2104		MN10J4105	MN57J3102	MN72A1473	MN72A1474
5/32(4 <sup>m</sup> /m)	MN50J5101	MN72J3104		MN10J5105	MN57J4102	MN72A1473	MN72A1474
3/16(4.8 <sup>m</sup> /m)	MN50H6101	MN72J4104		MN10J6105	MN57J5102	MN72A1473	MN72A1474
7/32(5.6 <sup>m</sup> /m)	MN50J7101	MN72J5104		MN10J7105	MN57J6102	MN72A1473	MN72A1474
1/4(6.4 <sup>m</sup> /m)	MN50J8101	MN72J6104		MN10J8105	MN57J7102	MN72A1473	MN72A1474
5/16(8 <sup>m</sup> /m)	MN50J9101	MN72J7104		MN10J9105	MN57J9102	MN72A2473	MN72A1474
3/8(9.5 <sup>m</sup> /m)	MN50K1101	MN72J8104		MN10K1105	MN57K1102	MN72A2473	MN72A1474
TYPE MITW							
3/32(2.4 <sup>m</sup> /m)	MN50J3101	MN50J3104	MN50J3104	MN10J3105	MN57J2102	MN72A1473	MN72A1474
1/8(3.2 <sup>m</sup> /m)	MN50J4101	MN50J4104	MN60J4104	MN10J4105	MN57J3102	MN72A1473	MN72A1474
5/32(4 <sup>m</sup> /m)	MN50J5101	MN50J5104	MN51J5104	MN10J5105	MN57J4102	MN72A1473	MN72A1474
3/16(4.8 <sup>m</sup> /m)	MN50H6101	MN50J6104	MN51H6104	MN10J6105	MN57J5102	MN72A1473	MN72A1474
7/32(5.6 <sup>m</sup> /m)	MN50J7101	MN50J7104	MN51J7104	MN10J7105	MN57J6102	MN72A1473	MN72A1474
1/4(6.4 <sup>m</sup> /m)	MN50J8101	MN50J8104	MN51J8104	MN10J8105	MN57J7102	MN72A1473	MN72A1474
5/16(8 <sup>m</sup> /m)	MN50J9101	MN50J9104	MN51J9104	MN10J9105	MN57J9102	MN72A2473	MN72A1474
3/8(9.5 <sup>m</sup> /m)	MN50K1101	MN50K1104	MN51K1104	MN10K1105	MN57K1102	MN72A2473	MN72A1474
1/2(12.7 <sup>m</sup> /m)	MN50K3101	MN50K3104	MN51K3104	MN10K3105	MN57K3102	MN72A3473	MN72A1474
5/8(16 <sup>m</sup> /m)	MN50K4101	MN50K4104	MN51K4104	MN10K4105	MN57K5102	MN72A3473	MN72A1474
3/4(19.1 <sup>m</sup> /m)	MN50K5101	MN50K5104	MN51K5104	MN10K5105	MN57K6102	MN72A4473	MN72A2474
1(25.4 <sup>m</sup> /m)	MN50K6101	MN50K6104	MN51K6104	MN10K6105	MN57K8102	MN72A5473	MN72A2474
1 <sup>1</sup> / <sub>8</sub> (28.5 <sup>m</sup> /m)	MN50K7101	MN50K7104	MN51K7104	MN10K7105	MN57K9102	MN72A6473	MN72A2474
1 <sup>1</sup> / <sub>4</sub> (31.8 <sup>m</sup> /m)	MN50K8101	MN50K8104	MN51K8104	MN10K8105	MN58K1102	MN72A6473	MN72A2474
1 <sup>1</sup> / <sub>2</sub> (38.1 <sup>m</sup> /m)	MN50K9101	MN50K9104	MN72K1104	MN10K9105	MN58K3102	MN72A7473	MN72A2474
TYPE BIT							
3/32(2.4 <sup>m</sup> /m)	MN52J3101	MN52J3104		MN52J3105	MN57J2102	MN72A1473	MN72A1474
1/8(3.2 <sup>m</sup> /m)	MN52J4101	MN52J4104		MN26J4105	MN57J3102	MN72A1473	MN72A1474
5/32(4 <sup>m</sup> /m)	MN52J5101	MN52J5104		MN52J5105	MN57J4102	MN72A1473	MN72A1474
3/16(4.8 <sup>m</sup> /m)	MN52J6101	MN52J6104		MN26J6105	MN57J5102	MN72A1473	MN72A1474
7/32(5.6 <sup>m</sup> /m)	MN52J7101	MN52J7104		MN52J7105	MN57J6102	MN72A1473	MN72A1474
1/4(6.4 <sup>m</sup> /m)	MN52J8101	MN52J8104		MN26J8105	MN57J7102	MN72A1473	MN72A1474
5/16(8 <sup>m</sup> /m)	MN52J9101	MN52J9104		MN26J9105	MN57J9102	MN72A2473	MN72A1474
3/8(9.5 <sup>m</sup> /m)	MN52K1101	MN52K1104		MN26K1105	MN57K1102	MN72A2473	MN72A1474
1/2(12.7 <sup>m</sup> /m)	MN52K3101	MN52K3104		MN26K3105	MN57K3102	MN72A3473	MN72A1474
5/8(16 <sup>m</sup> /m)	MN52K4101	MN52K4104		MN52K4105	MN57K5102	MN72A3473	MN72A1474
3/4(19.1 <sup>m</sup> /m)	MN52K5101	MN52K5104		MN52K5105	MN57K6102	MN72A4473	MN72A2474
1(25.4 <sup>m</sup> /m)	MN52K6101	MN52K6104		MN52K6105	MN57K8102	MN72A5473	MN72A2474
1 <sup>1</sup> / <sub>8</sub> (28.5 <sup>m</sup> /m)	MN52K7101	MN52K7104		MN52K7105	MN57K9102	MN72A6473	MN72A2474
1 <sup>1</sup> / <sub>4</sub> (31.8 <sup>m</sup> /m)	MN52K8101	MN52K8104		MN52K8105	MN58K1102	MN72A6473	MN72A2474
1 <sup>1</sup> / <sub>2</sub> (38.1 <sup>m</sup> /m)	MN72K1101	MN52K9104		MN70J2105	MN58K3102	MN72A7473	MN72A2474