

三菱工業用ミシン部品カタログ

MITSUBISHI

Industrial Sewing Machine Parts Catalog

Model

DB-130G

目次	INDEX	Page
1. 機 構 図	Total assembly	
2. 本 体 関 係	Arm bed & its accessories	1
3. 天 秤・針 棒 関 係	Thread take-up lever & needle bar mechanism	5
4. 上 軸・豎 軸 関 係	Arm shaft & vertical shaft mechanism	7
5. 送 り 調 節 器 関 係	Stich length regulator mechanism	9
6. 押 工 関 係	Presser foot mechanism	11
7. 水 平 送 り 軸・上 下 送 り 軸 関 係	Feed rock shaft & feed lifting shaft mechanism	13
8. 下 軸・カ マ 関 係	Rotating hook shaft & rotating hook mechanism	15
9. 給 油 関 係	Lubricaton mechanism	17
10. 付 属 品 箱 関 係	Accessory box & its accessories	19
11. 油 槽、トソノ他付属品関係	Oil reservoir & other accessories	21

本体関係

ARM BED & ITS ACCESSORIES

DB-130G

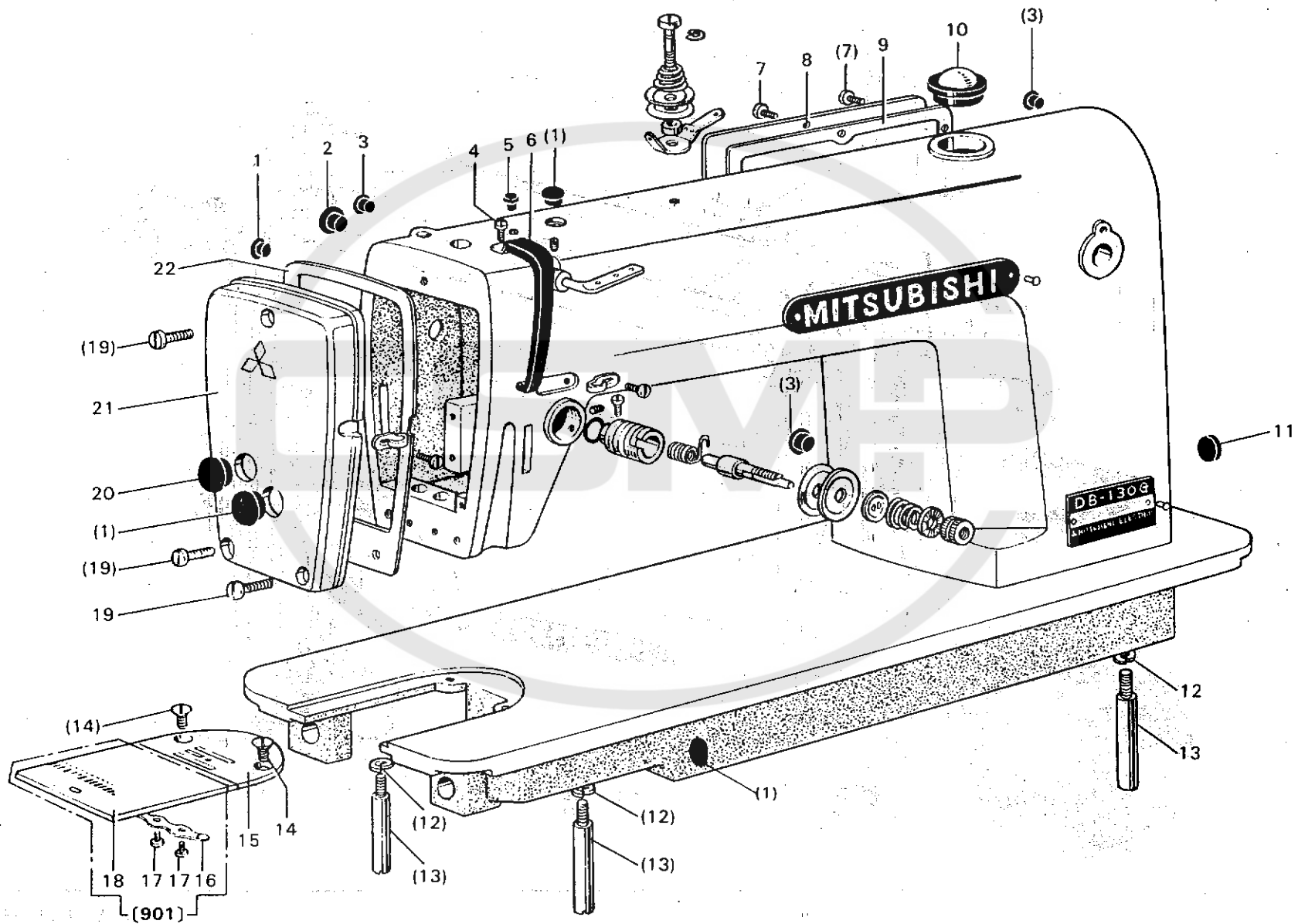

本体関係

ARM-BED & ITS ACCESSORIES

Fig. No.	部品コード Parts No.	資材コード Ref. No.	部 品 名	Description	使用 個数 Amt. Req.	共通部品 Common Parts																	
						DB-130G-10	DB-130G-11	DB-130G-12-7	DB-130G-22	DB-130E-10	DB-130E-11	DB-130E-12-7	DB-130E-22										
1	M9 1180 080	W502069H01	ゴ ム 栓 (φ11.8)	Rubber plug (φ11.8)	4	○	○	○	○														
2	M9 1900 080	W501374H01	ゴ ム 栓 (φ19)	Rubber plug (φ19)	1	○	○	○	○	○	○	○	○	○	○								
3	M9 0880 080	W501320H01	ゴ ム 栓 (φ8.8)	Rubber plug (φ8.8)	4	○	○	○	○	○	○	○	○	○	○								
4	M9 1107 002	W500092H01	平 ネ ジ 11/64(40)×5.5	Screw 11/64(40)×5.5	1	○	○	○	○	○	○	○	○	○	○								
5	M9 0570 080	W502078H01	ゴ ム 栓 (φ5.7)	Rubber plug (φ5.7)	1	○	○	○	○														
6	MF 10A0 584	W468291H01	天 秤 カ バ ー	Thread take-up cover	1	○	○	○		○	○	○											
	MF 17B0 584	W458150H01	天 秤 カ バ ー (2倍ガマ)	Thread take-up cover	1					○						○							
7	M9 1101 004	W466810H01	ブ ラ マ イ ネ ジ 11/64(40)× 8	Screw 11/64(40)× 8	8	○	○	○	○	○	○	○	○	○	○								
8	MF 80A0 880	W344943H01	横 蓋	Arm side cover	1	○	○	○	○	○	○	○	○	○	○								
9	MF 80A0 691	W344944H01	ガ ス ケ ッ ト (横蓋)	Gasket for arm side cover	1	○	○	○	○	○	○	○	○	○	○								
10	MF 20A0 135	P 674006X01	油 窓	Oil check window	1	○	○	○	○	○	○	○	○	○	○								
11	M9 2700 080	W486306H01	ゴ ム 栓 (φ27)	Rubber plug (φ27)	1	○	○	○	○														
12	M9 0621 053	S 561111H02	バ ネ 座 金 #6	Spring washer for leg #6	3	○	○	○	○	○	○	○	○	○	○								
13	MF 10A0 151	W452343H01	脚	Leg	3	○	○	○	○	○	○	○	○	○	○								
14	M9 1102 011	W500197H01	丸 皿 ネ ジ 11/64(40)×7	Screw 11/64(40)×7	2	○	○	○	○	○	○	○	○	○	○								
15	MF 11D0 101	W326261H01	針 板 (B.1.6)	Needle plate (B1.6)	1	○				○													
	MF 21D1 101	W324529H01	針 板 (A.1.6)	Needle plate (A1.6)	1		○				○												
	MF 26B0 101	W322721H01	針 板 (B.2.6)7mm	Needle plate (B2.6) 7mm	1			○	○					○	○								
16	MF 10A0 471	B 419207H01	板 バ ネ (スベリ板)	Spring for slide plate	1	○	○	○	○	○	○	○	○	○	○								
17	M9 0604 002	B 509070H01	平 ネ ジ 3/32(56)×2.2	Screw 3/32(56)×2.2	2	○	○	○	○	○	○	○	○	○	○								
18	MG 30A0 470	B 419208H02	ス ベ リ 板	Slide plate	1	○	○	○	○														
901	MF 80E0 470	W461757G02	ス ベ リ 板 (組)	Slide plate complete	1	○	○	○	○														
19	M9 1102 004	W467880H01	ブ ラ マ イ ネ ジ 11/64(40)×10	Screw 11/64(40)×10	3	○	○	○	○	○	○	○	○	○	○								
20	M9 5002 080	W472710H01	ゴ ム 栓 (φ19)	Rubber plug(φ19)	1	○	○	○	○	○	○	○	○	○	○								
21	MF 20A1 830	W331470H02	面 板	Face plate	1	○	○	○	○														
22	MF 70A2 691	W470264H02	ガ ス ケ ッ ト (面板)	Gasket for face plate	1	○	○	○	○	○	○	○	○	○	○								

本体関係

ARM-BED & ITS ACCESSORIES

DB-130G

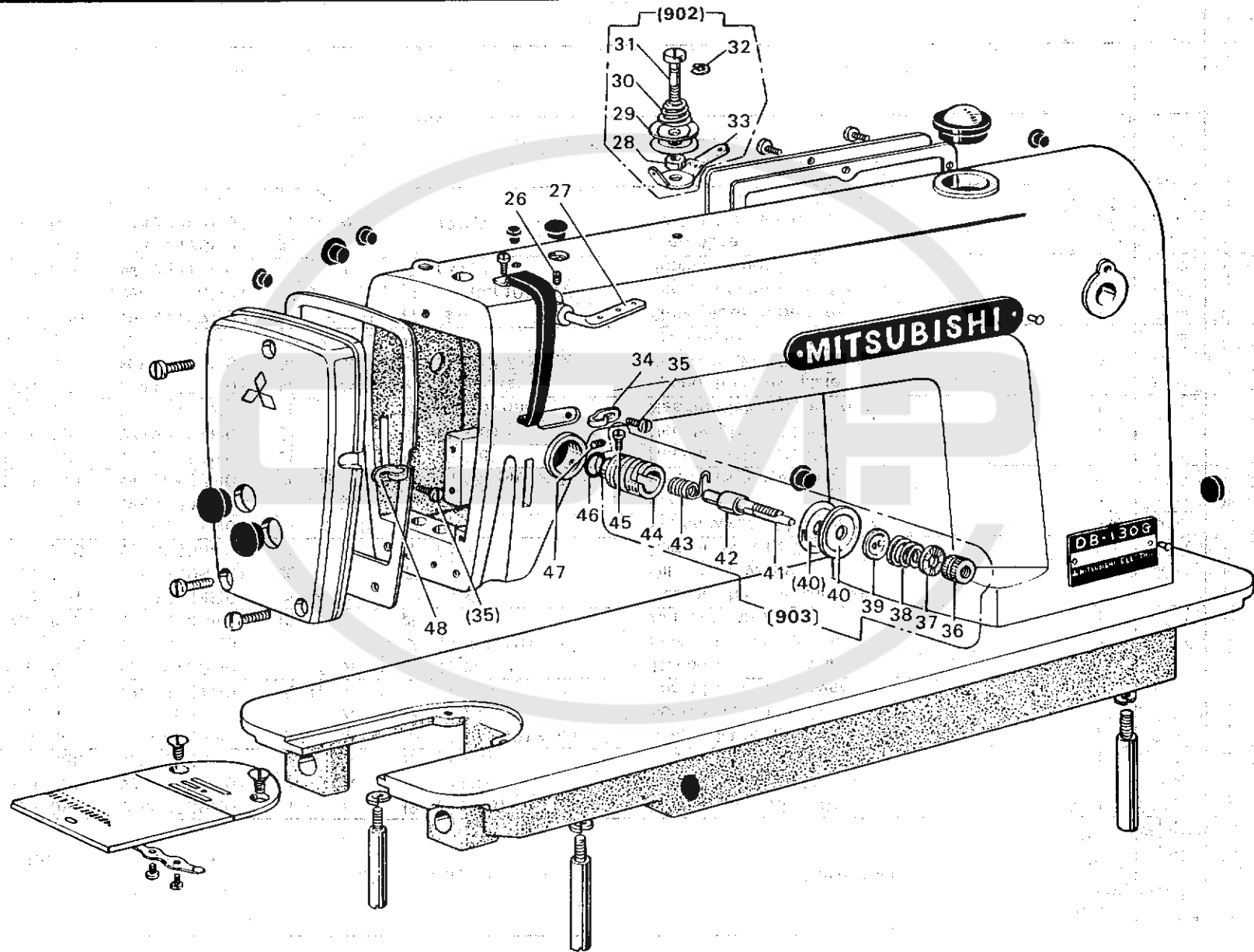

本体関係

ARM-BED & ITS ACCESSORIES

Fig. No.	部品コード Parts No.	資材コード Ref. No.	部 品 名	Description	使用 個数 Amt. Req.	共通部品 Common Parts																
						DB-130-G-10	DB-130G-11	DB-130G-12-7	DB-130G-22	DB-130E-10	DB-130E-11	DB-130E-12-7	DB-130E-22									
26	M9 1108 001	B 503846H01	頭ナシ止メネジ 11/64(40)×5.5	Set screw 11/64(40)×5.5	1	○	○	○	○	○	○	○	○									
27	MF 10A0 180	B 409034H01	系 案 内 (上) (三ツ目系掛)	Three hole thread guide	1	○	○	○	○	○	○	○	○									
28	MF 20A0 476	W470268H01	ス ペ ー サ (プリテンション)	Spacer for pre-tension	1	○	○	○	○	○	○	○	○									
29	MF 10A1 555	W501636H01	調 子 皿 (プリテンション)	Tension discs for pre-tension	2	○	○	○	○	○	○	○	○									
30	MF 20A0 245	W475419H01	円 錐 バ ネ (プリテンション)	Tension spring for pre-tension	1	○	○	○	○	○	○	○	○									
31	M9 1104 016	W470267H01	段付丸平ネジ 11/64(40)×16	Screw type tension stud	1	○	○	○	○	○	○	○	○									
32	M9 0503 065	S 592411H03	E 形 止 め 輪 #3	E-type stop ring #3	1	○	○	○	○	○	○	○	○									
33	MF 70A0 180	W481446H01	系 案 内 (プリテンション)	Thread guide for pre-tension	1	○	○	○	○	○	○	○	○									
902	MF 70E0 550	W341647G01	プリテンション (組)	Pre-tension complete	1	○	○	○	○	○	○	○	○									
34	MF 80A0 181	W483484H01	系 案 内 (中)	Thread guide for arm center	1	○	○	○	○	○	○	○	○									
	MF 83A0 181	W483485H01	系 案 内 (中) (2倍ガマ)	Thread guide for arm center	1					○				○								
35	M9 0909 003	W501901H01	丸 平 ネ ジ 9/64(40)×6	Screw 9/64(40)×6	2	○	○	○	○	○	○	○	○									
36	M9 1608 046	W476469H01	調 節 ナ ッ ト (上系調節器)	Thumb nut for thread tension regulator	1	○	○	○	○	○	○	○	○									
37	MT 60A0 802	W476470H01	回 り 止 め (上系調節器)	Thumb nut revolution stopper	1	○	○	○	○	○	○	○	○									
38	MN 10A3 245	W461785H01	円 錐 バ ネ (上系調節器) (標準)	Thread tension spring	1	○	○			○	○											
	MF 10A0 245	W450071H01	円 錐 バ ネ (上系調節器) (厚物)	Thread tension spring	1			○	○			○	○									
39	MM 11A0 556	W477611H01	調 子 皿 押 エ (上系調節器)	Thread tension releasing discs	1	○	○	○	○	○	○	○	○									
40	MF 10A0 555	W444059H01	調 子 皿 (上系調節器)	Thread tension discs	2	○	○	○	○	○	○	○	○									
41	M9 0204 060	B 509216H01	ピ ン (上系調節器)	Thread tension releasing pin	1	○	○	○	○	○	○	○	○									
42	MF 10A0 553	B 419178H01	調 子 棒	Thread tension stud	1	○	○	○	○	○	○	○	○									
43	MF 80A1 187	W486372H01	系 取 リ バ ネ (上系調節器) (標準)	Thread take-up spring	1	○	○			○	○											
	MF 83A1 187	W486372H02	系 取 リ バ ネ (上系調節器) (厚物)	Thread take-up spring	1					○	○			○								
44	MF 10A0 709	W453140H01	ブ ッ シ ュ (上系調節器)	Thread tension regulating bushing	1	○	○	○	○	○	○	○	○									
45	M9 0901 002	W500741H01	平 ネ ジ 9/64(40)×4	Set screw 9/64(40)×4	1	○	○	○	○	○	○	○	○									
46	M9 1501 085	P 648001X01	オ リ ン グ S15	Rubber ring S15	1	○	○	○	○	○	○	○	○									
47	M9 1508 001	B 509088H01	頭ナシ止メネジ 15/64(28)×8	Set screw 15/64(28)×8	3	○	○	○	○	○	○	○	○									
48	MF 10A0 181	W452151H01	系 案 内 (面板)	Thread guide for face plate	1	○	○	○	○	○	○	○	○									
	MF 17B0 181	W470968H01	系 案 内 (面板) (2倍ガマ)	Thread guide for face plate	1					○				○								
903	MF 80E0 210	W346065G01	上 系 調 節 器 (組) (標準)	Thread tension regulator complete	1	○	○															
	MF 82E0 210	W346065G02	上 系 調 節 器 (組) (厚物)	Thread tension regulator complete	1			○	○													

天秤・針棒関係

THREAD TAKE-UP LEVER & NEEDLE BAR MECHANISM

DB-130G

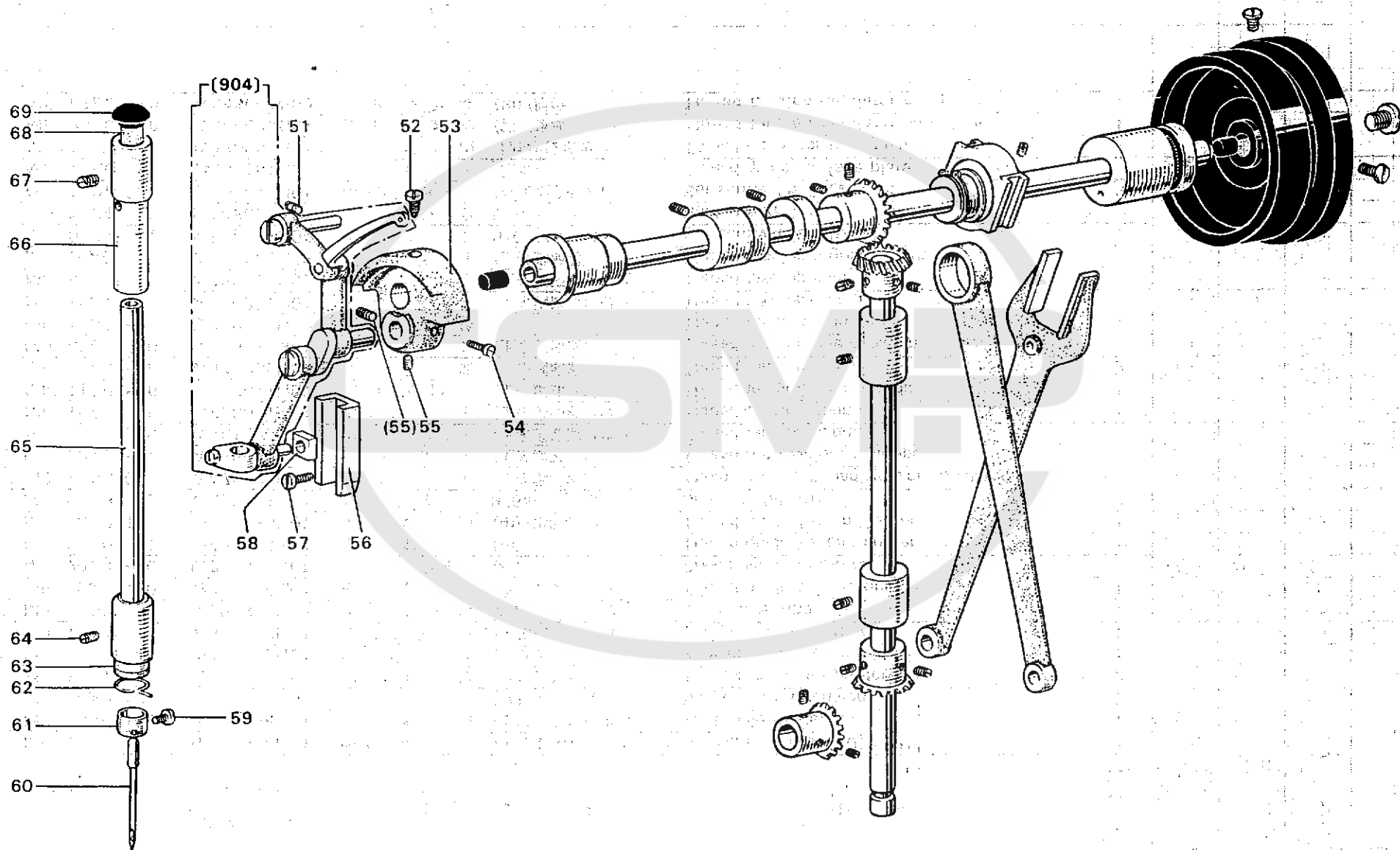

天秤・針棒関係

THREAD TAKE-UP LEVER & NEEDLE BAR MECHANISM

Fig. No.	部品コード Parts No.	資材コード Ref. No.	部 品 名	Description	使用 個数 Amt. Req.	共通部品 Common Parts												
						DB-130G-10	DB-130G-11	DB-130G-12-7	DB-130G-22	DB-130E-10	DB-130E-11	DB-130E-12-7	DB-130E-22					
904	MF 80E0 580	W346054G01	天秤針ク(組)(標準)	Thread take-up lever complete	1	○	○											
	MF 82E0 580	W346054G02	天秤針ク(組)(厚物)	Thread take-up lever complete	1			○										
	MF 83E0 580	W346054G03	天秤針ク(組)(2倍ガマ)	Thread take-up lever complete	1				○									
51	M9 1516 001	W500006H01	頭ナシ止メネジ 15/64(28)×13	Set screw 15/64(28)×13	1	○	○	○	○	○	○	○	○					
52	M9 1802 006	B 503851H01	棒先平ネジ 9/32(28)×14	Set screw 9/32(28)×14	1	○	○	○	○	○	○	○	○					
53	MF 80E0 383	W484898H01	クランク(標準)	Crank	1	○		○										
	MF 81E0 383	W486325H01	クランク(薄物)	Crank	1		○											
54	M9 1801 002	W500306H01	平ネジ 9/32(28)×13	Set screw 9/32(28)×13	1	○	○	○	○	○	○	○	○					
55	M9 1608 001	B 504016H01	頭ナシ止メネジ 1/4(40)×6	Set screw 1/4(40)×6	2	○	○	○	○									
56	MF 80A0 662	W444056H02	針棒クランクガイド(案内台)	Needle bar connecting link guide	1	○	○	○	○	○	○	○	○					
57	M9 1110 002	W500294H01	平ネジ 11/64(40)×8	Screw 11/64(40)×8	2	○	○	○	○	○	○	○	○					
58	MF 10A0 325	W443934H01	角駒(針棒ダキ)	Square block	1	○	○	○	○	○	○	○	○					
59	M9 0815 002	W484210H01	平ネジ 1/8(44)×4.5	Needle clamp screw 1/8(44)×4.5	1	○	○	○	○									
60	MF 70A0 128	S 970010H01	ミシン針 DB×1-2-14	Needle DB×1-2-14	1	○				○								
	MF 21D0 128	S 970001H01	ミシン針 DA×1 #11	Needle DA×1 #11	1		○				○							
	MF 83A0 128	S 970002H03	ミシン針 DB×1 #22	Needle DB×1 #22	1			○	○			○	○					
61	MF 80A1 181	W486318H01	糸案内(糸カケ)(針棒)	Thread guide for needle bar	1	○	○	○	○	○	○	○	○					
62	MF 10A1 181	W502073H01	糸案内(針棒メタル下)	Thread guide for needle bar bushing	1	○	○	○	○	○	○	○	○					
63	MF 10A0 664	W450055H01	針棒メタル(下)(標準)	Needle bar bushing (lower)	1	○	○	○	○	○	○	○	○					
	MF 17B0 664	W457585H01	針棒メタル(下)(2倍ガマ)	Needle bar bushing (lower)	1			○					○					
64	M9 1102 001	W500489H01	頭ナシ止メネジ 11/64(40)×2.7	Set screw 11/64(40)×2.7	1	○	○	○	○	○	○	○	○					
65	MF 80A0 660	W486319H01	針棒(標準)	Needle bar	1	○												
	MF 81A0 660	W486321H01	針棒(薄物)	Needle bar	1		○											
	MF 82A0 660	W486322H01	針棒(厚物)	Needle bar	1			○										
	MF 83A0 660	W486310H01	針棒(2倍ガマ)	Needle bar	1				○									
66	MF 70A0 663	W481449H01	針棒メタル(上)	Needle bar bushing (upper)	1	○	○	○	○	○	○	○	○					
67	M9 1503 001	B 508971H01	頭ナシ止メネジ 15/64(28)×4.5	Set screw 15/64(28)×4.5	1	○	○	○	○	○	○	○	○					
68	MF 10A2 740	W500003H01	フェルト(針棒メタル上)	Felt for Needle bar bushing (upper)	1	○	○	○	○									
69	M9 0881 080	W502944H01	ゴム栓 φ8.8(針棒メタル上)	Rubber plug φ8.8	1	○	○	○	○									

上軸・豎軸関係

ARM SHAFT & VERTICAL SHAFT MECHANISM

DB-130G

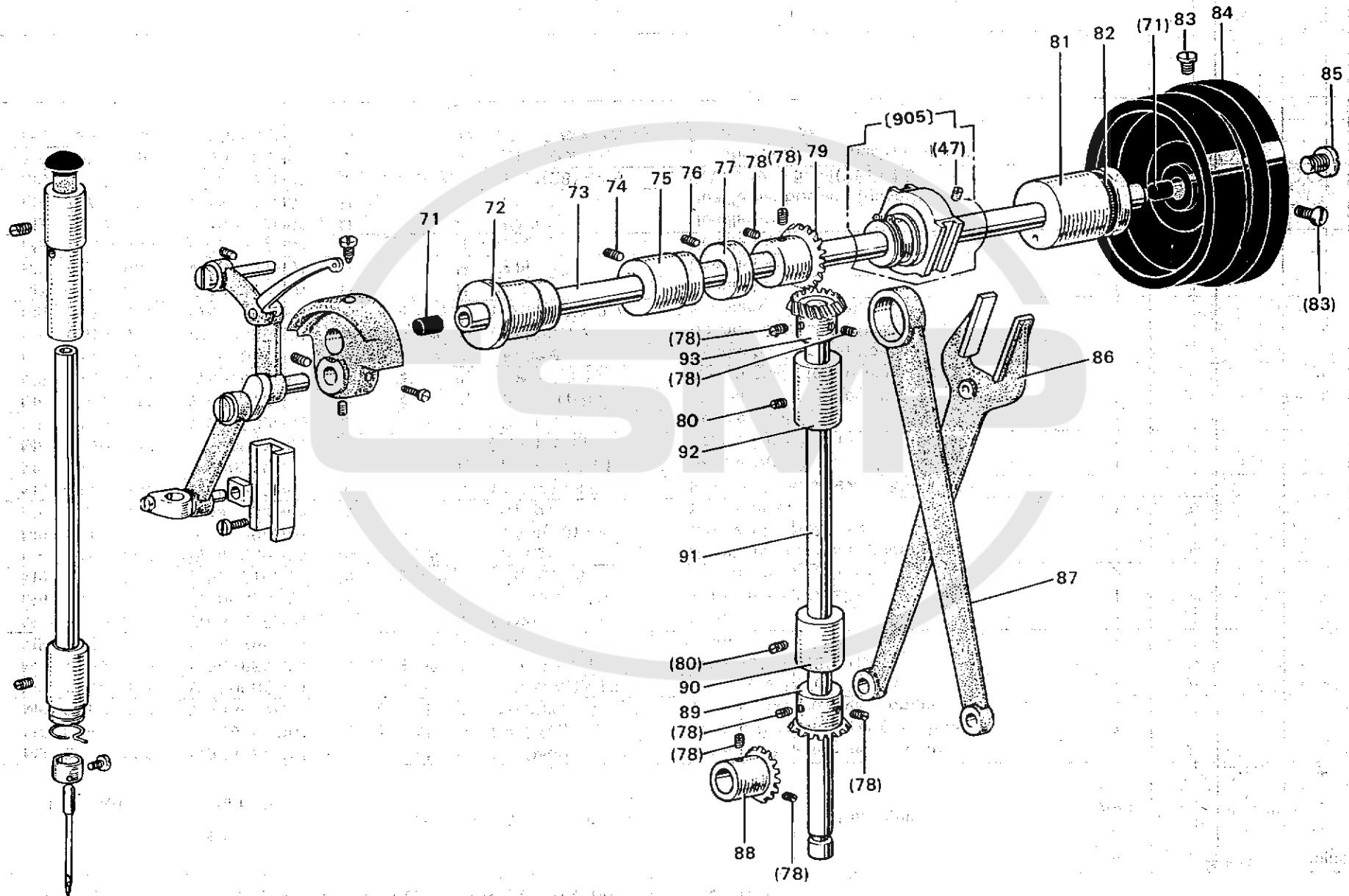

上軸・縦軸関係

ARM SHAFT & VERTICAL SHAFT MECHANISM

Fig. No.	部品コード Parts No	資材コード Ref. No.	部 品 名	Description	使用 個数 Amt. Req.	共通部品 Common Parts														
						DB-130G-10	DB-130G-11	DB-130G-12-7	DB-130G-22	DB-130E-10	DB-130E-11	DB-130E-12-7	DB-130E-22							
71	M9 0740 080	W478175H01	ゴム栓 (上軸) $\phi 7.4 \times 10$	Rubber plug for arm shaft $\phi 7.4 \times 10$	2	○	○	○	○	○	○	○								
72	MF 80A0 232	W486300H01	上軸メタル (左)	Bushing for arm shaft (left)	1	○	○	○	○											
73	MF 80A0 230	W346047H01	上軸	Arm shaft	1	○	○	○	○											
74	M9 1516 001	W500006H01	頭ナシ止メネジ $15/64(28) \times 15$	Set screw $15/64(28) \times 15$	1	○	○	○	○	○	○	○								
75	MF 70A0 234	W481452H01	上軸メタル (中)	Bushing for arm shaft (middle)	1	○	○	○	○	○	○	○								
76	M9 1602 001	W500036H01	頭ナシ止メネジ $1/4(40) \times 4$	Set screw $1/4(40) \times 4$	2	○	○	○	○	○	○	○								
77	MF 70A0 352	W476422H01	カラ (上軸)	Collar for arm shaft	1	○	○	○	○	○	○	○								
78	M9 1606 001	P 911000X01	頭ナシ止メネジ $1/4(40) \times 7$	Set screw $1/4(40) \times 7$	8	○	○	○	○	○	○	○								
79	MF 10A0 331	P 611003X02	傘歯車 (上軸)	Bevel gear for arm shaft	1	○	○	○	○	○	○	○								
905	MF 70E0 280	W481451G01	偏心輪 (組) (送りカム)	Feed cam complete	1	○	○	○	○	○	○	○								
80	M9 1513 001	B 509060H01	頭ナシ止メネジ $15/64(28) \times 10.5$	Set screw $15/64(28) \times 10.5$	2	○	○	○	○	○	○	○								
81	MF 70A0 233	W481413H01	上軸メタル (右)	Bushing for arm shaft (right)	1	○	○	○	○	○	○	○								
82	M9 1473 086	W481476H01	オイルシール (上軸右)	Oil seal for arm shaft (right)	1	○	○	○	○	○	○	○								
83	M9 1502 002	W500509H01	平ネジ $15/64(28) \times 12$	Set screw $15/64(28) \times 12$	2	○	○	○	○	○	○	○								
84	MF 10A0 682	W453500H01	ハズミ車	Balance wheel	1	○	○	○	○	○	○	○								
85	M9 2201 003	W461726H01	丸平ネジ $11/32(28) \times 10$	Screw $11/32(28) \times 10$	1	○	○	○	○	○	○	○								
86	MF 10A0 744	W320448H01	フタ又	Feed forked connecting rod	1	○	○			○	○									
	MF 26B0 744	W327698H01	フタ又 (7mm)	Feed forked connecting rod (7mm feed)	1			○	○		○	○								
87	MF 70A0 384	W450961H01	クランクロッド (連接桿)	Crank rod for feed lifting rock shaft	1	○	○	○	○	○	○	○								
88	MF 10A0 332	P 611002X02	傘歯車 (下軸)	Bevel gear for hook shaft	1	○	○	○	○	○	○	○								
89	MF 10A0 334	P 611001X02	傘歯車 (縦軸下)	Bevel gear for vertical shaft (lower)	1	○	○	○	○	○	○	○								
90	MF 70A0 522	W481418H02	縦軸メタル (下)	Bushing for vertical shaft (lower)	1	○	○	○		○	○	○								
	MF 74B0 522	W481696H01	縦軸メタル (下) (2倍ガマ)	Bushing for vertical shaft (lower)	1				○			○								
91	MF 10A0 520	W450080H01	縦軸	Vertical shaft	1	○	○	○	○											
92	MF 70A0 521	W481418H03	縦軸メタル (上)	Bushing for vertical shaft (upper)	1	○	○	○	○	○	○	○								
93	MF 10A0 333	P 611000X02	傘歯車 (縦軸上)	Bevel gear for vertical shaft (upper)	1	○	○	○	○	○	○	○								

送り調節器関係

STITCH LENGTH REGULATOR MECHANISM

DB-130G

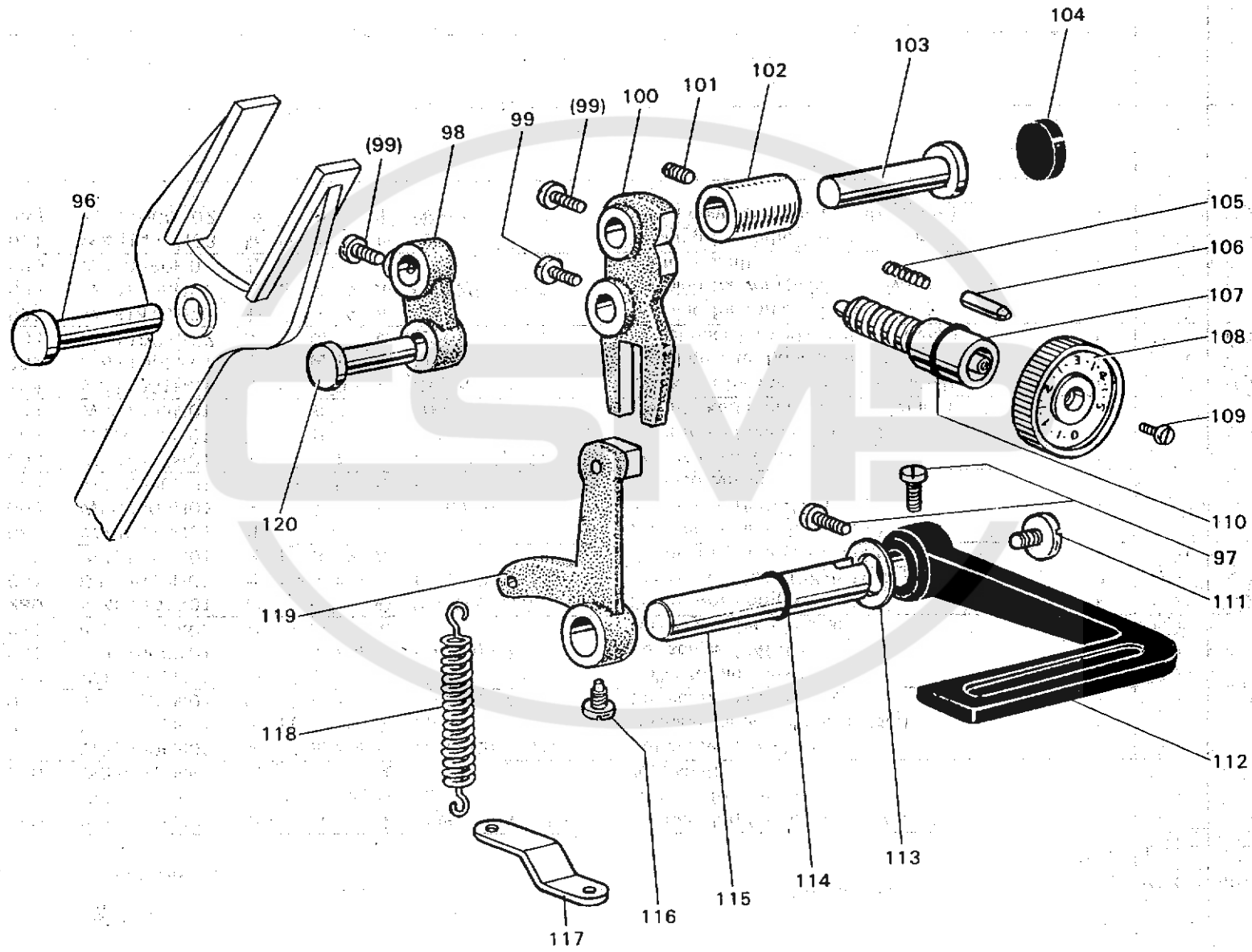

送り調節器関係

STITCH LENGTH REGULATOR MECHANISM

Fig. No.	部品コード Parts No.	資材コード Ref. No.	部 品 名	Description	使用 個数 Amt. Req.	共通部品 Common Parts														
						DB-130G-10	DB-130G-11	DB-130G-12-7	DB-130G-22	DB-130E-10	DB-130E-11	DB-130E-12-7	DB-130E-22							
96	M9 0718 063	W481425H01	段付キ軸 (フタ又) $\phi 7.2 \times 19$	Set pin $\phi 7.2 \times 19$	1	○	○	○	○	○	○	○	○							
97	M9 1501 002	W502945H01	平ネジ $15/64(28) \times 8.5$	Screw $15/64(28) \times 8.5$	2	○	○	○	○	○	○	○	○							
98	MF 70A0 153	W481677H01	連結桿 (案内テコ継ぎ)	Feed connecting link	1	○	○	○	○	○	○	○	○							
99	M9 1504 002	B 508963H01	平ネジ $15/64(28) \times 10$	Screw $15/64(28) \times 10$	3	○	○	○	○	○	○	○	○							
100	MF 80A0 152	W447221H02	案内テコ	Feed regulator	1	○	○													
	MF 82A1 152	W336661H02	案内テコ (7mm)	Feed regulator (7mm feed)	1			○												
101	M9 1513 001	B 509060H01	頭ナシ止メネジ $15/64(28) \times 11$	Set screw $15/64(28) \times 11$	1	○	○	○	○	○	○	○	○							
102	MF 70A0 750	W479396H03	ブッシュ (案内テコ)	Bushing for feed regulator	1	○	○	○	○	○	○	○	○							
103	M9 0904 063	W479395H01	段付キ軸 (案内テコ)	Set pin	1	○	○	○	○	○	○	○	○							
104	M9 2001 080	W479394H01	ゴム栓 (案内テコ) $\phi 20 \times 4$	Rubber plug $\phi 20 \times 4$	1	○	○	○	○	○	○	○	○							
105	MF 10A2 572	B 509164H01	ツル巻バネ (戻り止め)	Spring for stopper pin	1	○	○	○	○	○	○	○	○							
106	MF 80A0 852	W481688H02	戻り止め (縫目加減ダイヤル)	Stopper pin for stitch length regulator	1	○	○	○	○											
107	MF 80A0 641	W484899H01	ネジ棒	Screw bar	1	○	○	○	○											
108	MF 10A0 631	W331475H01	ダイヤル (縫目加減0-5)	Dial for stitch length regulator (0-5)	1	○				○										
	MF 11D0 631	W331486H01	ダイヤル (縫目加減0-4)	Dial for stitch length regulator (0-4)	1		○				○									
	MF 26B0 631	W331487H01	ダイヤル (縫目加減0-7)	Dial for stitch length regulator (0-7)	1			○	○				○	○						
109	M9 1209 002	B 503887H01	平ネジ $3/16(28) \times 8$	Screw $3/16(28) \times 8$	1	○	○	○	○	○	○	○	○							
110	M9 1000 085	S 648001H06	Oリング $\phi 10$ (ネジ棒)	O-ring $\phi 10$ for screw bar	1	○	○	○	○	○	○	○	○							
111	M9 1207 003	B 509288H01	丸平ネジ $3/16(28) \times 6.5$	Screw $3/16(28) \times 6.5$	1	○	○	○	○	○	○	○	○							
112	MF 80A0 632	W346067H01	レバー (縫目加減)	Reverse sewing lever	1	○	○	○	○	○	○	○	○							
113	M9 5003 053	B 503895H01	バネ座金 (レバー)	Spring washer	1	○	○	○	○	○	○	○	○							
114	M9 0600 085	S 648001H04	Oリング $\phi 6$ (軸)	O-ring for reverse sewing lever shaft	1	○	○	○	○	○	○	○	○							
115	MF 10A0 633	W450088H01	軸 (縫目加減)	Shaft for reverse sewing lever	1	○	○	○	○	○	○	○	○							
116	M9 1501 007	B 509256H01	棒先丸平ネジ $15/64(28) \times 14.5$	Screw $15/64(28) \times 14.5$	1	○	○	○	○	○	○	○	○							
117	MF 10A0 708	W501378H01	バネ止め板	Bracket for spring	1	○	○	○	○	○	○	○	○							
118	MF 10A0 572	W447225H01	ツル巻バネ (縫目加減)	Spring for reverse sewing crank	1	○	○	○	○	○	○	○	○							
119	MF 40E1 635	W462614G03	縫目加減腕 (コロ・ネジ付キ) (組)	Reverse sewing crank complete	1	○	○	○	○											
120	M9 0905 063	W501377H01	ピン (案内テコ継ぎ)	Set pin for feed connecting link	1	○	○	○	○	○	○	○	○							

押工関係

PRESSER-FOOT MECHANISM

DB-130G

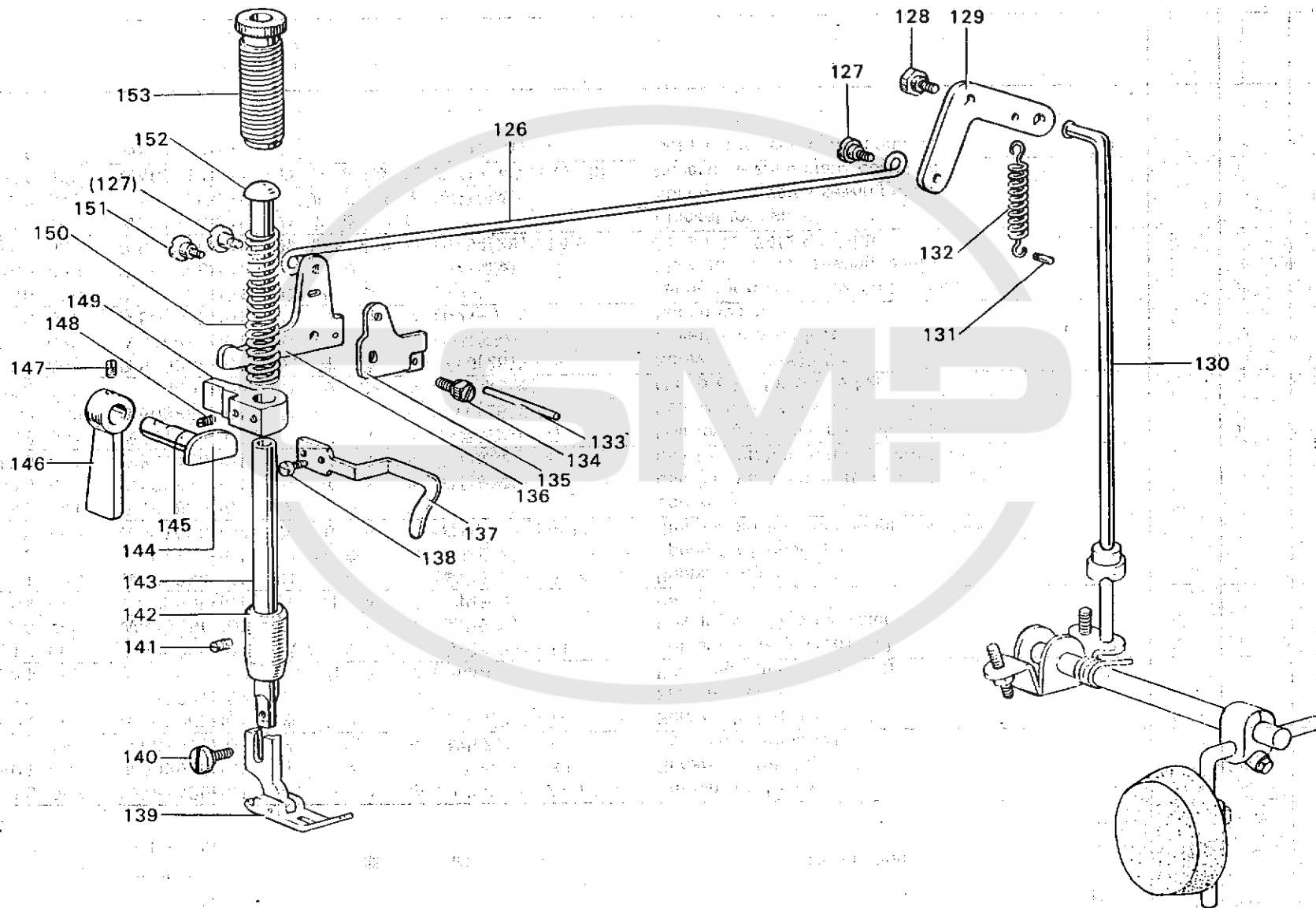

水平送り軸・上下送り軸関係

FEED ROCK SHAFT & FEED LIFTING SHAFT MECHANISM

DB-130G

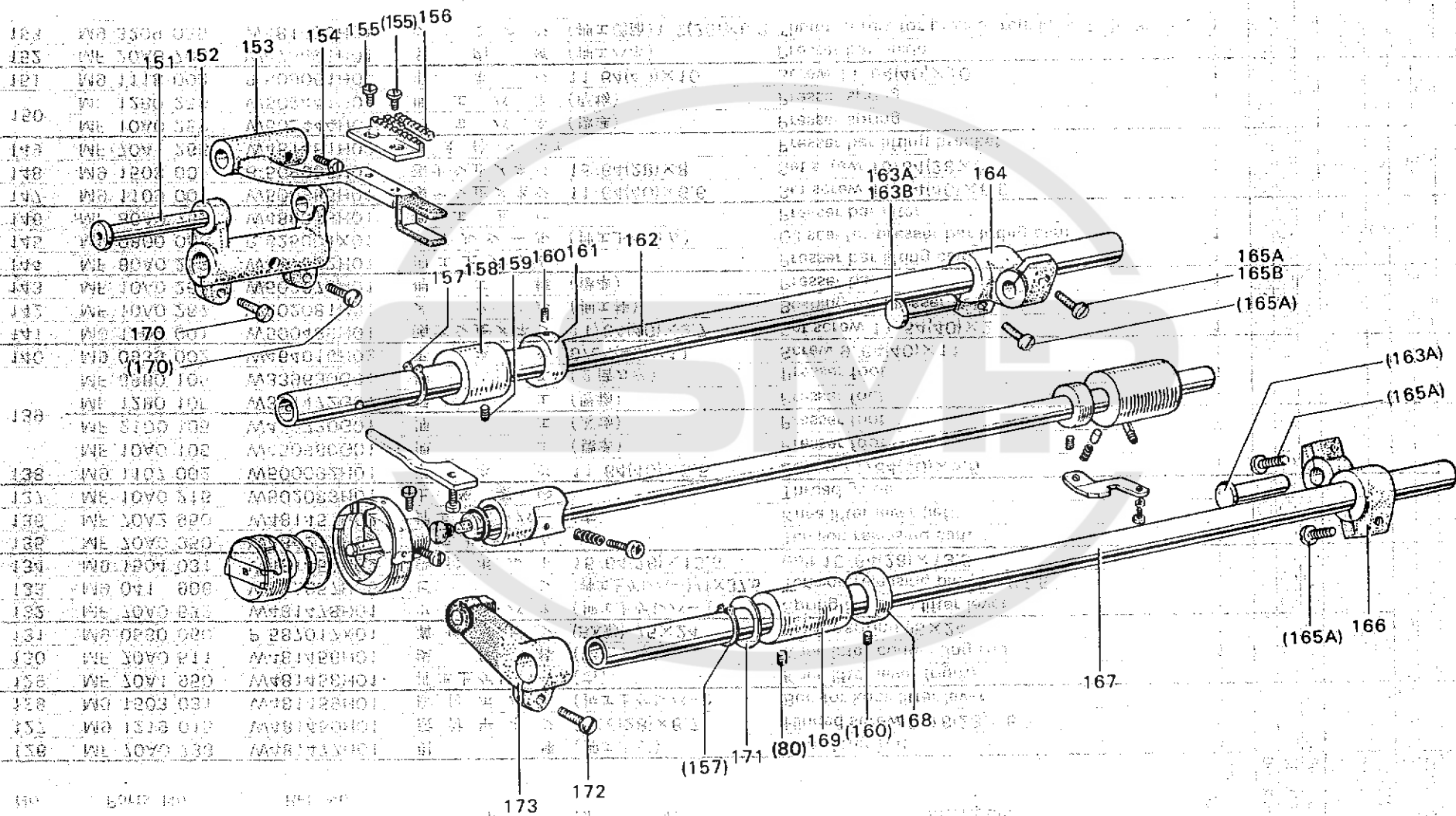

水平送り軸・上下送り軸関係

FEED ROCK SHAFT & FEED LIFTING SHAFT MECHANISM

Fig. No.	部品コード Parts No.	資材コード Ref. No.	部 品 名	Description	使用 個数 Amt. Req.	共通部品 Common Parts													
						DB-130G-10	DB-130G-11	DB-130G-12-7	DB-130G-22	DB-130E-10	DB-130E-11	DB-130E-12-7	DB-130E-22						
151	MF 70A0 283	W481422H01	軸 (送り台支エ)	Shaft for feed bar	1	○	○	○	○	○	○	○	○						
152	MF 70A0 278	W481421H01	送り腕 (水平左)	Feed rock shaft crank (left)	1	○	○	○	○	○	○	○	○						
153	MF 70A1 281	W484831H01	送り台	Feed bar	1	○	○	○	○										
154	M9 1103 002	B 509062H01	平ネジ 11/64(40)×5	Screw 11/64(40)×5	1	○	○	○	○	○	○	○	○						
155	M9 0806 002	B 508857H01	平ネジ 1/8(44)×6	Screw 1/8(44)×6	2	○	○	○	○	○	○	○	○						
156	MF 10A0 104	W462604H01	送り (標準3枚歯)	Feed dog	1	○		○	○	○		○	○						
	MF 11D0 104	W457555H01	送り (薄物4枚歯)	Feed dog	1		○					○							
157	M9 0315 065	S 591411H15	C形止め輪 (軸用15)	C-type stop ring	2	○	○	○	○	○	○	○	○						
158	MF 70A1 286	W481475H01	水平送り軸メタル (左)	Bushing for feed rock shaft (left)	1	○	○	○	○	○	○	○	○						
159	M9 1503 001	B 508971H01	頭ナシ止メネジ 15/64(28)×4.5	Set screw 15/64(28)×4.5	1	○	○	○	○	○	○	○	○						
160	M9 1602 001	W500036H01	頭ナシ止メネジ 1/4(40)×4	Set screw 1/4(40)×4	4	○	○	○	○	○	○	○	○						
161	MF 80A0 352	W482357H01	カラ	Collar	1	○	○	○	○										
162	MF 70A0 491	W481420H01	水平送り軸	Feed rock shaft	1	○	○	○	○	○	○	○	○						
163A	M9 0904 060	W502476H02	ピン (ツバツキ軸)φ9.53×21	Pin for feed rock shaft crank (right)	2	○	○			○	○	○	○						
163B	M9 0906 060	W486307H01	ピン (ツバツキ軸)φ9.53×21	Pin for feed rock shaft crank (right)	1			○	○										
164	MF 70A0 279	W481473H01	送り腕 (水平右)	Feed rock shaft crank (right)	1	○	○			○	○								
	MF 83A0 279	W486308H01	送り腕 (水平右)	Feed rock shaft crank (right)	1			○	○										
165A	M9 1204 003	B 508978H01	丸平平ネジ 3/16(28)×12	Screw 3/16(28)×12		4	4	3	3	○	○								
165B	M9 1515 002	B 508963H02	平ネジ 15/64(28)×10	Screw 15/64(28)×10				1	1										
166	MF 80A0 277	W486374H01	上下送り腕 (右)	Feed lifting rock shaft crank (right)	1	○	○	○	○	○	○	○	○						
167	MF 70A0 460	W481673H02	上下送り軸	Feed lifting rock shaft	1	○	○	○	○	○	○	○	○						
168	MF 70A0 352	W476422H01	カラ	Collar for feed lifting rock shaft	1	○	○	○	○	○	○	○	○						
169	MF 70A0 286	W481663H01	上下送り軸メタル (左)	Bushing for feed lifting rock shaft (left)	1	○	○	○	○	○	○	○	○						
170	M9 1513 001	B 509178H01	平ネジ 3/16(28)×15	Screw	2	○	○	○	○	○	○	○	○						
171	M9 1502 050	W481674H01	座金	Washer	1	○	○	○	○	○	○	○	○						
172	M9 1112 002	W501889H01	平ネジ 11/64(40)×12	Screw 11/64(40)×12	1	○	○	○	○										
173	MF 70E0 276	W484828G01	腕 (組)(送り腕上下左)	Crank complete for feed lifting rock shaft	①	○	○	○	○										
174	M9 1203 002	B 509178H01	平ネジ 3/16(28)×15	Screw	2	○	○	○	○										

下軸・カマ関係

ROTATING HOOK SHAFT & ROTATING HOOK MECHANISM

DB-130G

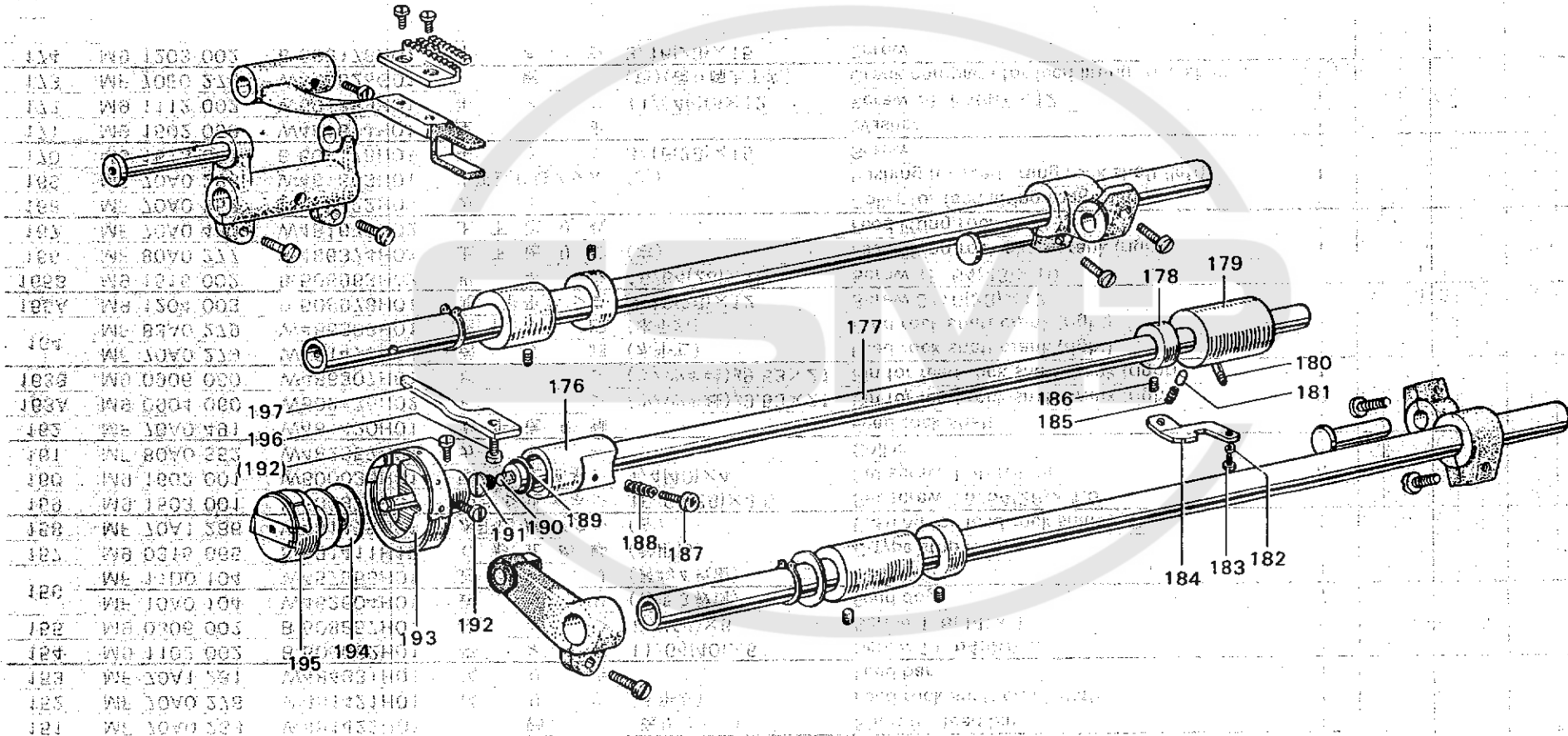

NO	品名	数量	単位	備考
172	軸	1	個	
173	ナット	1	個	
174	ワッシャー	1	個	
175	ピン	1	個	
176	ブッシュ	1	個	
177	軸	1	個	
178	ブラケット	1	個	
179	シリンダ	1	個	
180	フック	1	個	
181	ピン	1	個	
182	スプリング	1	個	
183	レバー	1	個	
184	ナット	1	個	
185	ワッシャー	1	個	
186	ブッシュ	1	個	
187	ピン	1	個	
188	スプリング	1	個	
189	ブッシュ	1	個	
190	ピン	1	個	
191	ブラケット	1	個	
192	ブッシュ	1	個	
193	ピン	1	個	
194	ブッシュ	1	個	
195	ピン	1	個	
196	ブッシュ	1	個	
197	ピン	1	個	

ROTATING HOOK SHAFT & ROTATING HOOK MECHANISM

下軸・カマ関係

下軸・カマ関係

ROTATING HOOK SHAFT & ROTATING HOOK MECHANISM

Fig. No.	部品コード Parts. No.	資材コード Ref. No.	部 品 名	Description	使用 個数 Amt. Req.	共通部品 Common Parts														
						DB-130G-10	DB-130G-11	DB-130G-12-7	DB-130G-22	DB-130E-10	DB-130E-11	DB-130E-12-7	DB-130E-22							
176	MF 80A0 451	W346051H01	下軸メタル(左)	Bushing for hook shaft (left)	1	○	○	○	○											
177	MF 80A0 450	W486311H01	下 軸 (標準)	Rotating hook shaft	1	○	○	○												
	MF 83A0 450	W486311H02	下 軸 (2倍ガマ)	Rotating hook shaft	1			○												
178	MF 10A0 352	B 422844H01	カ ラ ー (下軸)	Collar for hook shaft	1	○	○	○	○	○	○	○								
179	MF 80A0 452	W486309H01	下軸メタル(右)	Bushing for hook shaft (right)	1	○	○	○	○											
180	MF 80A0 688	W486304H01	パイプ	Pipe for hook shaft bushing	1	○	○	○	○											
181	M9 5008 063	W486305H01	プランジャー(特殊ピン)	Plunger	1	○	○	○	○											
182	M9 0601 053	S 561121H05	バネ座金	Spring washer	1	○	○	○	○											
183	M9 1515 002	B 508963H02	平ネジ 15/64(28)×10	Screw 15/64(28)×10	1	○	○	○	○											
184	MF 80A0 154	W486312H01	案内板	Guide plate	1	○	○	○												
	MF 83A0 154	W486312H02	案内板(2倍ガマ)	Guide plate	1			○												
185	MF 80A0 572	W486303H01	ツル巻バネ	Spring	1	○	○	○	○											
186	M9 1503 001	B 508971H01	頭ナシ止メネジ 15/64(28)×4.5	Set screw 15/64(28)×4.5	2	○	○	○	○	○	○	○								
187	M9 1506 030	W486327H01	特殊ネジ(油調節)	Oil adjusting screw	1	○	○	○	○											
188	MF 80A1 572	W486330H01	ツル巻バネ(油調節)	Spring for oil adjuster	1	○	○	○	○											
189	M9 0803 086	P 625002X01	オイルシール(下軸)	Oil seal for rotating hook shaft	1	○	○	○	○											
190	MF 70A4 740	W486324H01	フェルト	Felt for hook shaft	1	○	○	○	○											
191	M9 1251 030	W500190H01	特殊ネジ 3/16(32)×6.7	Special screw 3/16(32)×6.7	1	○	○	○	○	○	○	○								
192	M9 1101 002	W500194H01	平ネジ 11/64(40)×4.0	Set screw 11/64(40)×4.0	2	○	○	○	○	○	○	○								
193	MF 10A0 120	P 975008X01	カマ(HSL-BS(J)/KHS-12S)	Rotating hook (HSL-BS(J)/KHS-12SM)	1	○	○			○	○									
	MF 22B0 120	P 975010X01	カマ(HSL-AN/KHS-12R)	Rotating hook (HSL-AN/KHS-12R)	1			○				○								
	MF 25B0 120	P 975005X01	カマ(HSM-A/KHS-20RM2)	Rotating hook (HSM-A/KHS-20RM2)	1				○				○							
194	MF 10A0 123	W462632H01	ボビン(標準)	Bobbin	1	○	○	○		○	○	○								
	MF 25B0 123	W470215H01	ボビン(2倍ガマ)	Bobbin	1				○				○							
195	MF 10E0 125	P 976009X01	ボビンケース(標準)	Bobbin case	1	○	○	○		○	○	○								
	MF 25E0 125	P 976015X01	ボビンケース(2倍ガマ)	Bobbin case	1				○				○							
196	M9 1118 002	B 509061H01	平ネジ 11/64(40)×10	Screw 11/64(40)×10	1	○	○	○	○	○	○	○								
197	MF 10A0 229	W462633H01	内ガマ止メ(標準)	Rotating hook positioner	1	○	○			○	○									
	MF 17B0 229	W470246H01	内ガマ止メ(極厚)	Rotating hook positioner	1			○					○							
	MF 20A0 229	W468837H01	内ガマ止メ(2倍ガマ)	Rotating hook positioner	1				○					○						

給油関係

LUBRICATION MECHANISM

DB-130G

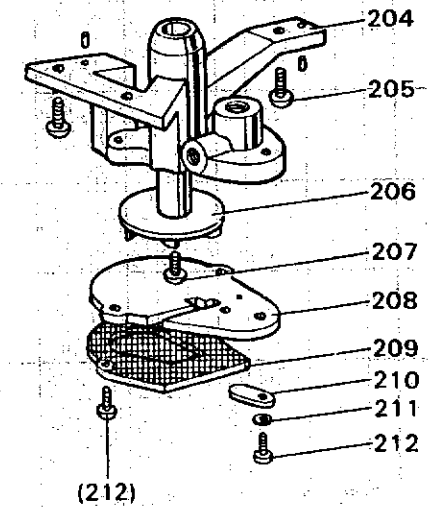
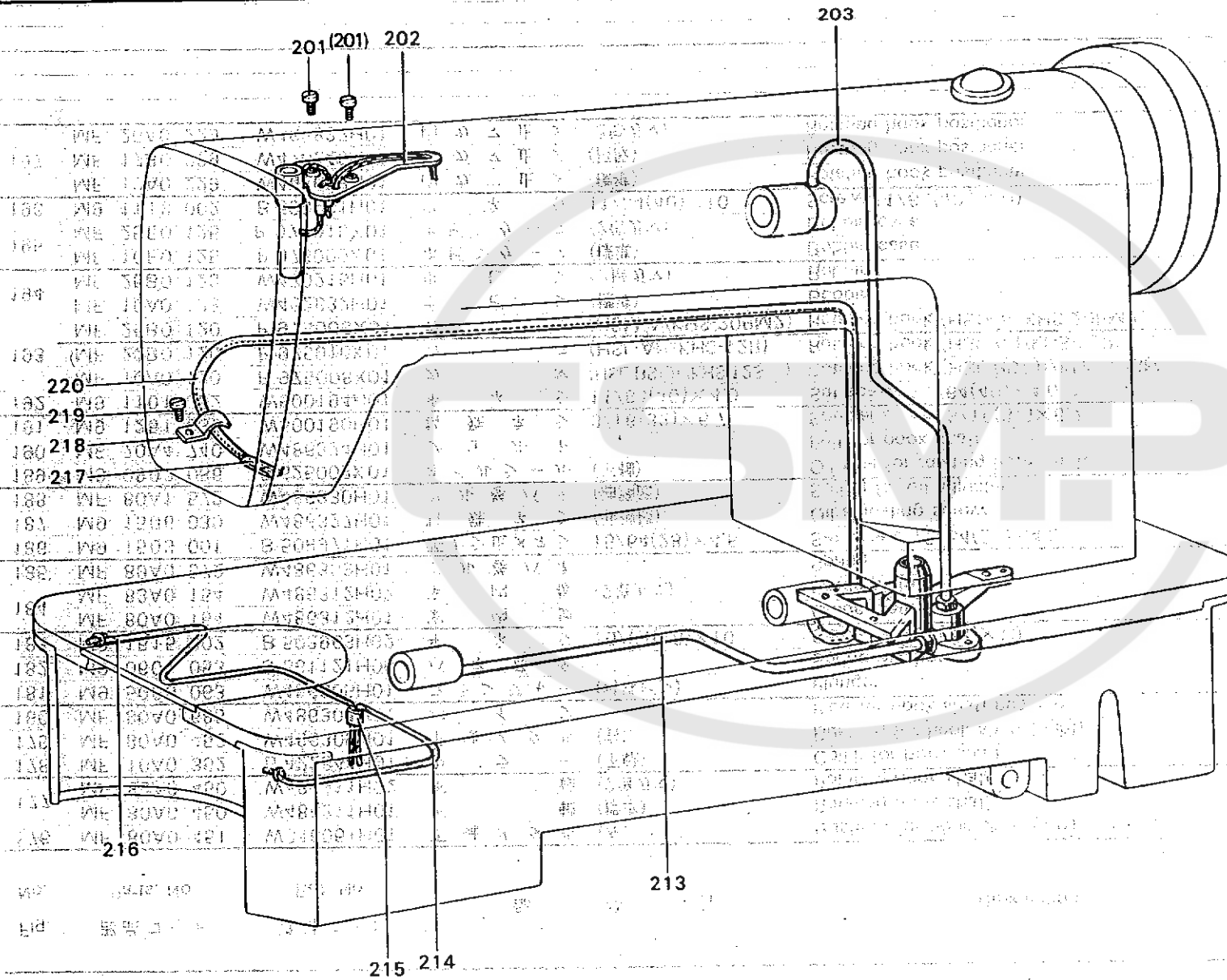

給油関係

LUBRICATION MECHANISM

Fig. No.	部品コード Parts No.	資材コード Ref. No.	部 品 名	Description	使用 個数 Amt. Req.	共通部品 Common Parts													
						DB-130G-10	DB-130G-11	DB-130G-12-7	DB-130G-22	DB-130E-10	DB-130E-12-7								
201	M9 0939 002	W464016H02	平 ネ シ 9/64(40)×11	Screw 9/64(40)×11	2	○	○	○	○										
202	MF 80A0 601	W486313G01	取 付 板 (紐付き)(組)	Oil braid fitting plate	1	○	○												
	MF 80A1 601	W486313G02	取 付 板 (紐付き)(組)	Oil braid fittir	1			○	○										
203	MF 80A1 688	W476410G02	バ イ プ (上軸給油)(組)	Oil pipe for arm shaft	1	○	○	○	○										
204	MF 80A0 783	W346046H01	ポンプケース	Oil pump (body)	1	○	○	○	○										
205	M9 1103 004	W467868H01	ブラマイネジ 11/64(40)×13	Screw 11/64(40)×13	3	○	○	○	○										
206	MF 10A0 685	W470288H01	羽 根 車	Oil pump impeller	1	○	○	○	○										
207	M9 0810 002	W501133H01	平 ネ シ 1/8(44)×8	Screw 1/8(44)×8	1	○	○	○	○										
208	MF 10A0 601	W461088H01	取 付 板	Oil pump fitting plate	1	○	○	○	○										
209	MF 10E0 337	W481402G01	金 網	Oil pump screen	1	○	○	○	○										
210	MF 10A1 742	W470250H01	蓋	Oil adjusting plate	1	○	○	○	○										
211	M9 0402 053	W500297H01	バ ネ 座 金	Spring washer	1	○	○	○	○										
212	M9 0801 004	W467881H01	ブラマイネジ 1/8(44)×13	Screw 1/8(44)×13	3	○	○	○	○										
213	MF 80A2 288	W461745G02	バ イ プ (下軸給油)(組)	Oil pipe for hook shaft	1	○	○	○	○										
214	MF 20E2 148	W444138H01	油 紐 (上下送り腕)φ2.5×240	Oil braid for feed lifting mechanism	1	○	○	○	○										
215	MF 80A0 680	W501092H01	ホ ル ダ	Holder for oil braid	1	○	○	○	○										
216	MF 10E2 148	W462982H01	油 紐 (水平送り腕)φ2.5×330	Oil braid for feed rock mechanism	1	○	○	○	○										
217	MF 10A0 740	W502394H01	フ ェ ル ト	Felt pouch for return oil filter	1	○	○	○	○										
218	MF 70A0 689	W484833H01	ホ ル ダ ー	Holder for oil pipe	1	○	○	○	○										
219	M9 1107 002	W500092H01	平 ネ シ 11/64(40)×5.5	Screw 11/64(40)×5.5	1	○	○	○	○										
220	MF 20A0 731	W484209H03	ビニールパイプ	Oil return pipe	1	○	○	○	○										

ACCESSORY BOX & ITS ACCESSORIES

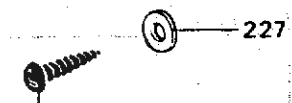
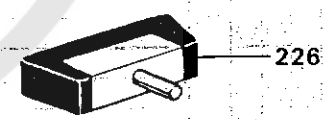
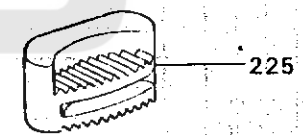
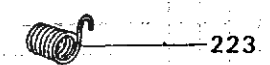
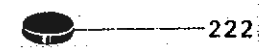
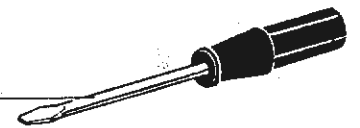
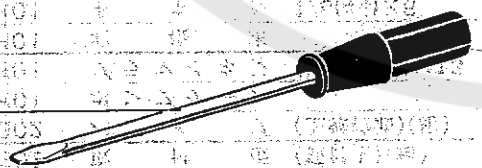
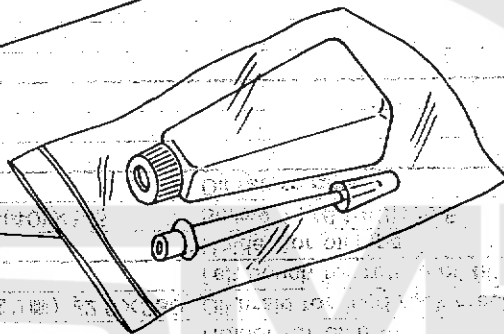
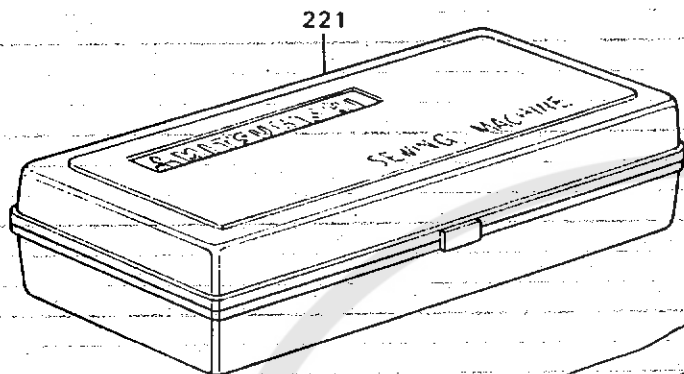

233
 232
 231
 230
 229

222
 223
 224
 225
 226
 227
 228

油槽、ソノ他付属品関係
OIL RESERVOIR & OTHER ACCESSORIES

DB-130G

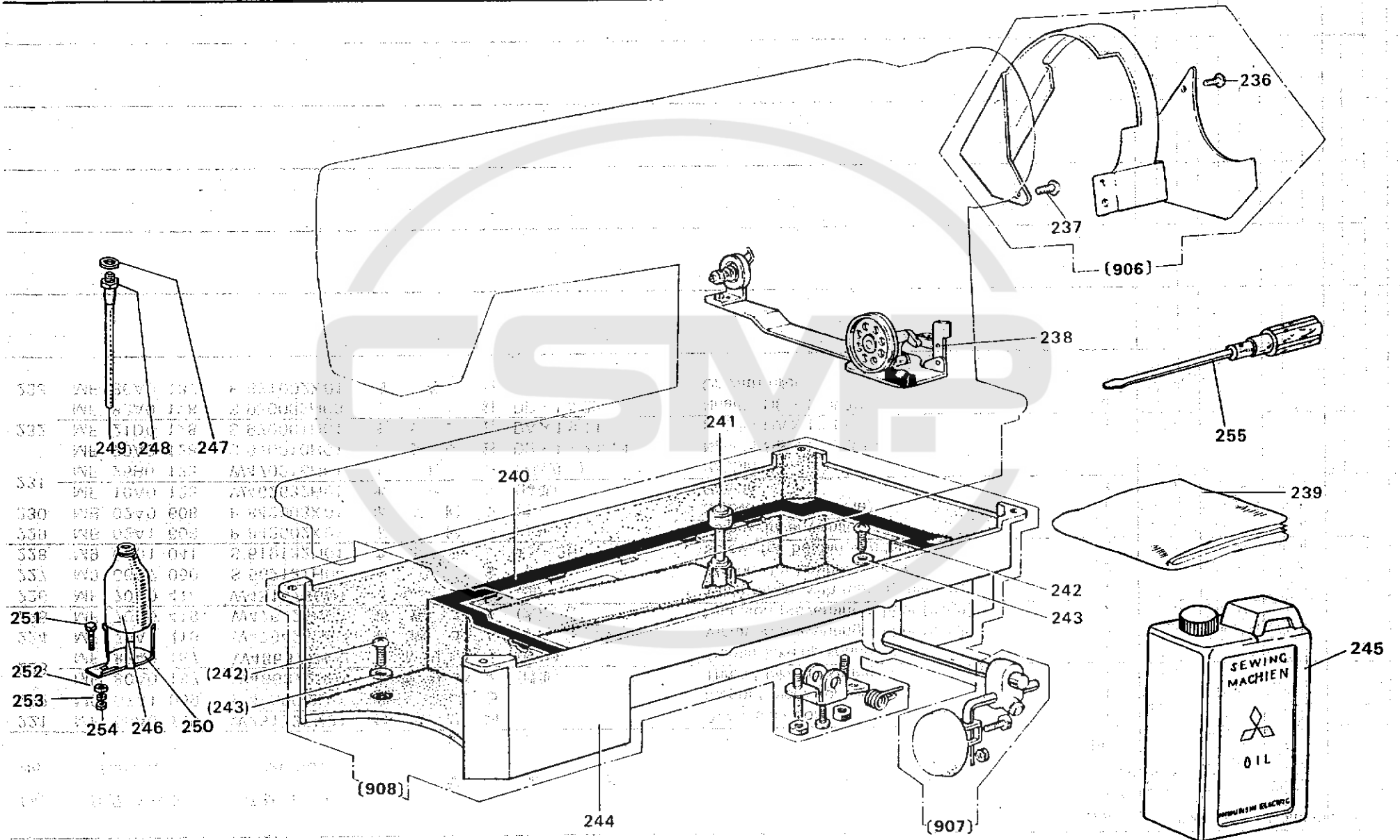

油槽、ソノ他付属品関係

油槽、ソノ他付属品関係

油槽、ソノ他付属品関係

OIL RESERVOIR & OTHER ACCESSORIES

Fig. No.	部品コード Parts No.	資材コード Ref. No.	部 品 名	Description	使用 個数 Amt. Req.	共通部品 Common Parts														
						DB-130G-10	DB-130G-11	DB-130G-12-7	DB-130G-22	DB-130E-10	DB-130E-11	DB-130E-12-7	DB-130E-22							
236	M9 1101 004	W466810H01	プライマネジ 11/64(40)×8	Screw 11/64(40)×8	3	○	○	○	○	○	○	○								
237	M9 1505 004	W467868H02	プライマネジ 15/64(28)×8	Screw 11/64(40)×8	3	○	○	○	○	○	○	○								
906	MF 20E0 776	W341683G01	ベルトカバー (組)(BE-2)	Belt cover complete (BE-2)	1	○	○			○	○									
	MF 25E0 776	W341683G08	ベルトカバー (組)(BE-11)	Belt cover complete (BE-11)	1			○	○			○	○							
238	MF 20E0 190	P 992002X01	糸巻仕掛 (組)	Bobbin winder complete	1	○	○	○		○	○	○								
	MF 25E0 190	P 992004X01	糸巻仕掛 (組)(2倍ガマ)	Bobbin winder complete	1				○				○							
239	MF 60A0 734	W220627H02	ビニールカバー	Vinyl cover	1	○	○	○	○	○	○	○	○	○						
240	MF 20A2 691	W471440H02	ガスケット (小)(油槽)	Gasket for oil reservoir (small)	1	○	○	○	○	○	○	○	○							
	MF 20A3 691	W471441H02	ガスケット (大)(油槽)	Gasket for oil reservoir (large)	1	○	○	○	○	○	○	○	○							
241	MF 70A0 578	W481685H02	膝上ゲビン	Knee lifter lifting rod	1	○	○	○	○	○	○	○								
242	M9 2002 002	W486334H01	平ネジ 5/16(28)×10	Oil drain screw 5/16(28)×10	2	2	2	2	1											
243	M9 7001 052	W470200H01	特殊座金	Washer	2	○	○	○	○	○	○	○								
907	MF 40E0 227	W341682G04	膝上ゲ仕掛 (組)	Knee lifter complete	1	○	○	○	○	○	○	○	○							
244	MF 90A0 139	W115610H01	油槽	Oil reservoir	1	○	○	○	○											
908	MT 70E0 139	W341681G01	油槽 (組)	Oil reservoir complete	1	○	○	○												
	MF 90E0 139	W341681G05	油槽 (組)	Oil reservoir complete	1				○											
245	MF 10E0 149	W227466H01	油缶	Oil can	1	○	○	○	○	○	○	○								
246	MF 20A0 130	W319422H01	油ビン	Oil bottle	1				○				○							
247	MF 10A4 691	W500812H01	ガスケット	Packing	1				○				○							
248	M9 2001 047	W446050H01	トクシュネジ	Screw	1					○				○						
249	MF 36A0 731	W451152H01	パイプ	Pipe	1					○				○						
250	MF 20A0 130	W453513H01	油受台	Oil bottle holder	1					○				○						
251	M9 1551 022	S 531121H04	ボルト 6×12	Bolt	1					○				○						
252	M9 0702 050	W502735H01	ザガネ	Washer	1					○				○						
253	M9 0601 053	S 561121H05	バネザガネ 6	Spring washer	1					○				○						
254	M9 1571 045	S 541121H04	ナット 6	Nut	1					○				○						
255	MF 60A0 608	W319408H01	ネジ回シ (大)	Screw driver (large)	1	○	○	○	○	○	○	○								

機構図

TOTAL ASSEMBLY

DB-130G

