

Pfaff

Mauser Spezial 4542

Mauser Spezial 4562

CSTMP

PFAFF

MAUSER SPEZIAL

4542

4562

Teileliste

List of parts

Liste de pièces

Lista de piezas



Achtung!

Ersatzteile bitte nur mit den im
Index aufgeführten **PFAFF-NUMMERN**
Bestellen (siehe Seiten 106 bis 113).

Important!

Veuillez commander les pièces de
rechange uniquement avec leur
référence complète précisée à
l'index (pages 106 à 113).

Important note:

For spare part orders please only
use the **PFAFF-NUMBERS** listed in
the index (pages 106 to 113).

Atencion!

Sírvanse hacer sus pedidos sólo
con los **NUMEROS-PFAFF** indicados
en el índice (véanse las
páginas 106 à 113).

TABLE OF CONTENTS

Page

MACHINE BED FRAME(1)	2-3
MACHINE BED FRAME(2)	4-5
COVER(1)	6-7
COVER(2) (4562.4542)	8-9
CRANKSHAFT MECHANISM	10-11
.....	
ARM SHAFT MECHANISM	12-13
NEEDLE BAR MECHANISM	14-15
NEEDLE GUARD MECHANISM	16-17
LOOPER MECHANISM	18-19
FEED MECHANISM(1) (4562.4542)	20-21
.....	
FEED MECHANISM(2) (4562.4542)	22-23
PRESSER FOOT MECHANISM	24-25
SPREDER MECHANISM	26-27
THREAD TENSION MECHANISM	28-29
NEEDLE-SPREDER THREAD HANDLING	30-31
.....	
LOOPER THREAD HANDLING	32-33
LOOPER THREAD HANDLING(OLD TYPE)	34-35
LUBRICATION MECHANISM	36-37
HR DEVICE	38-39
4562-02-4542-02 SPECIFIC PARTS	40-41
.....	
4562-05,06,07-4542-05,06,07 SPECIFIC PARTS	42-43
FT DEVICE	44-45
MD DEVICE(1)	46-47
MD DEVICE(2)	48-49
LACE GUIDE REEL STAND	50-51
.....	
4562-01DB-4561-01DB SPECIFIC PARTS	52-53
SEMI-SUBMERGED INSTALLTION PARTS	54-55
THREAD STAND	56-57
ACCESSORIES	58-59
GAUGE PARTS CONSTRUCTION CHARTS	60-93
.....	
GAUGE PARTS LIST	94-104
PART NUMBER INDEX	106-113

(EXAMPLE)

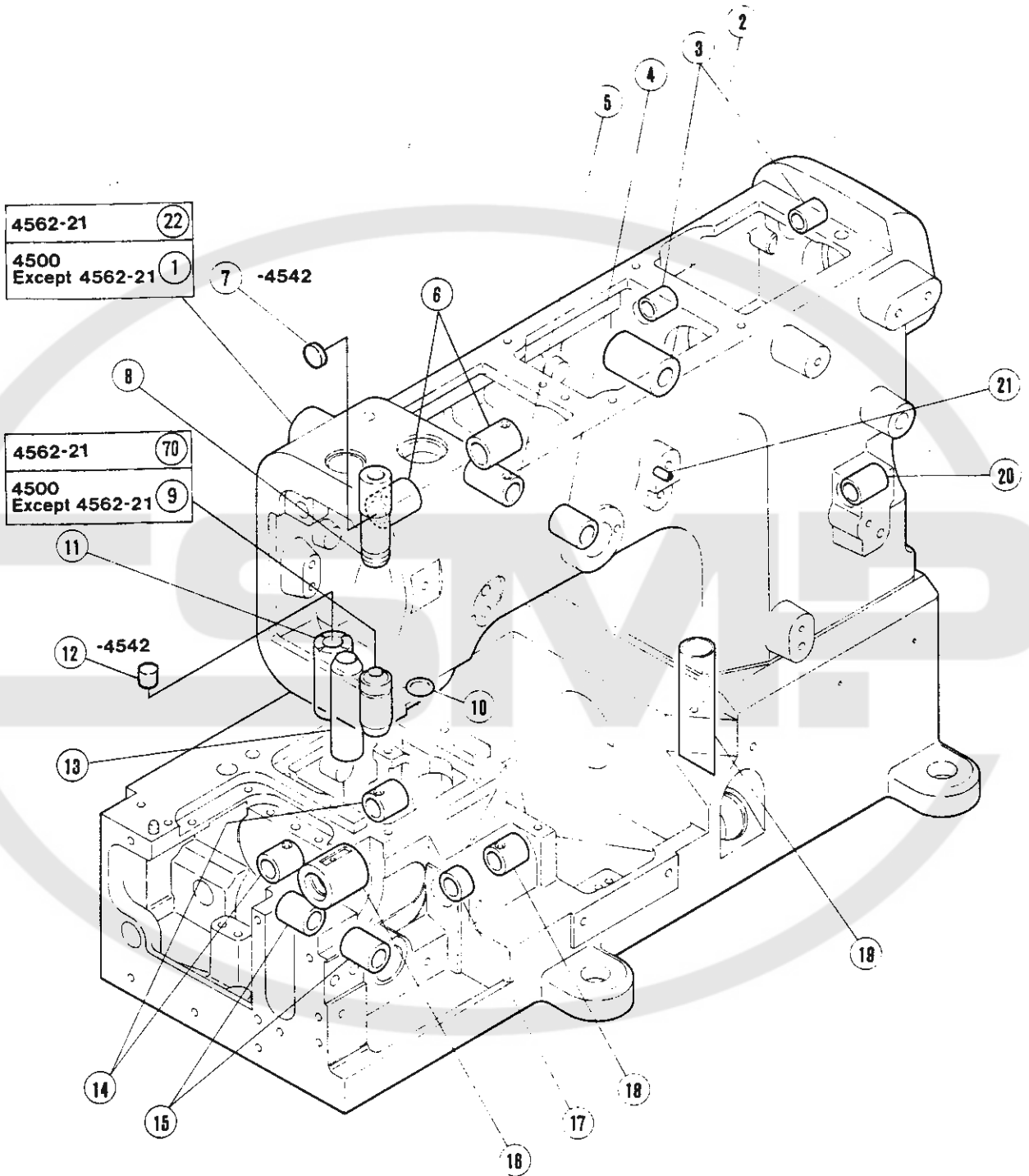

4500=4562-4542

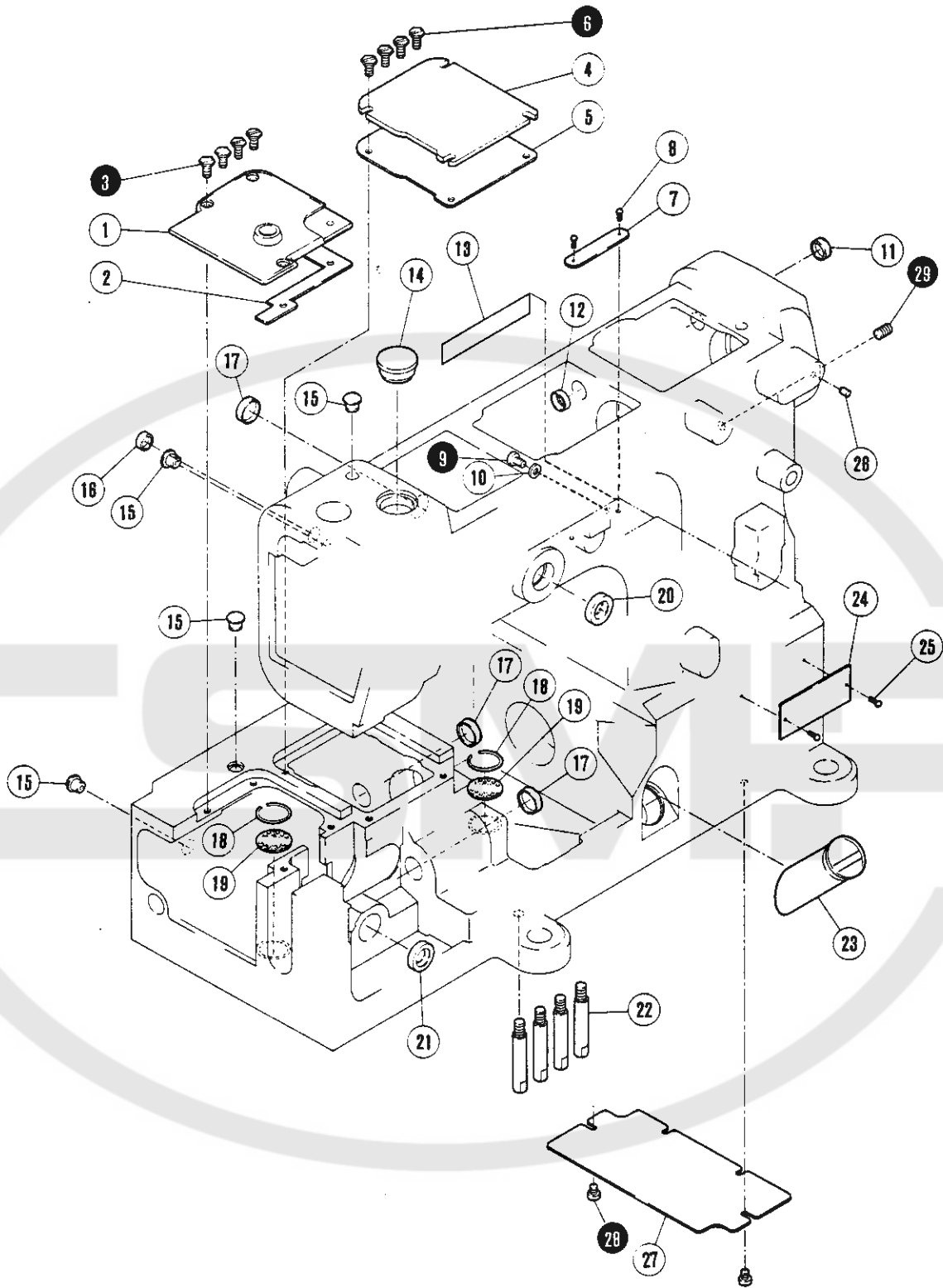

MACHINE BED FRAME (1)

REF. NO.	PART NO.	PFAFF-NO.	NAME	QT.
1	250069	09-009817-04	TOP COVER PLATE (LEFT)	1
2	250049	09-400218-00	GASKET	1
3	7084	09-400090-00	SCREW	4
4	250003	09-400193-00	TOP COVER (RIGHT)	1
5	250004	09-400194-00	GASKET	1
6	7084	09-400090-00	SCREW	4
* 7	230047A	09-009827-17	SERIAL NUMBER PLATE	1
* 8	230047	09-400154-00	SERIAL NUMBER PLATE	11 1 100789
8	210679	09-009617-74	PIN	2
9	7018	11-108171-15	SCREW	1
10	303448	12-305114-15	WASHER	1
11	240111	09-400171-00	PLUG	1
12	206942	09-400141-00	OIL SEAL	1
*13	202526	09-009601-69	NAME PLATE	1
14	240110	09-400170-00	PLUG	1
15	240052	91-179447-05	PLUG	4
16	205088	09-009604-86	PLUG	1
17	208173	09-009604-72	PLUG	3
18	240001	12-516311-05	RING	2
19	255002	09-400334-00	FILTER	2
20	210586	09-009617-44	OIL SEAL	1
21	210586	09-009617-44	OIL SEAL	1
22	204006	09-009601-82	BED PIN	4
23	206590	09-400137-00	OIL SIGHT GAUGE	1
*24	212281A	09-009824-91	TYPE PLATE	1
* 25	212281	91-179362-95	TYPE PLATE	11 1 100789
26	210679	09-009617-74	PIN	2
27	240127	09-400185-00	MARK	1
28	250020	09-400205-00	COVER	1
29	7017	11-108168-15	SCREW	2
30	4541	11-330280-15	SCREW	1

Notice) Parts with mark * are not for sale.

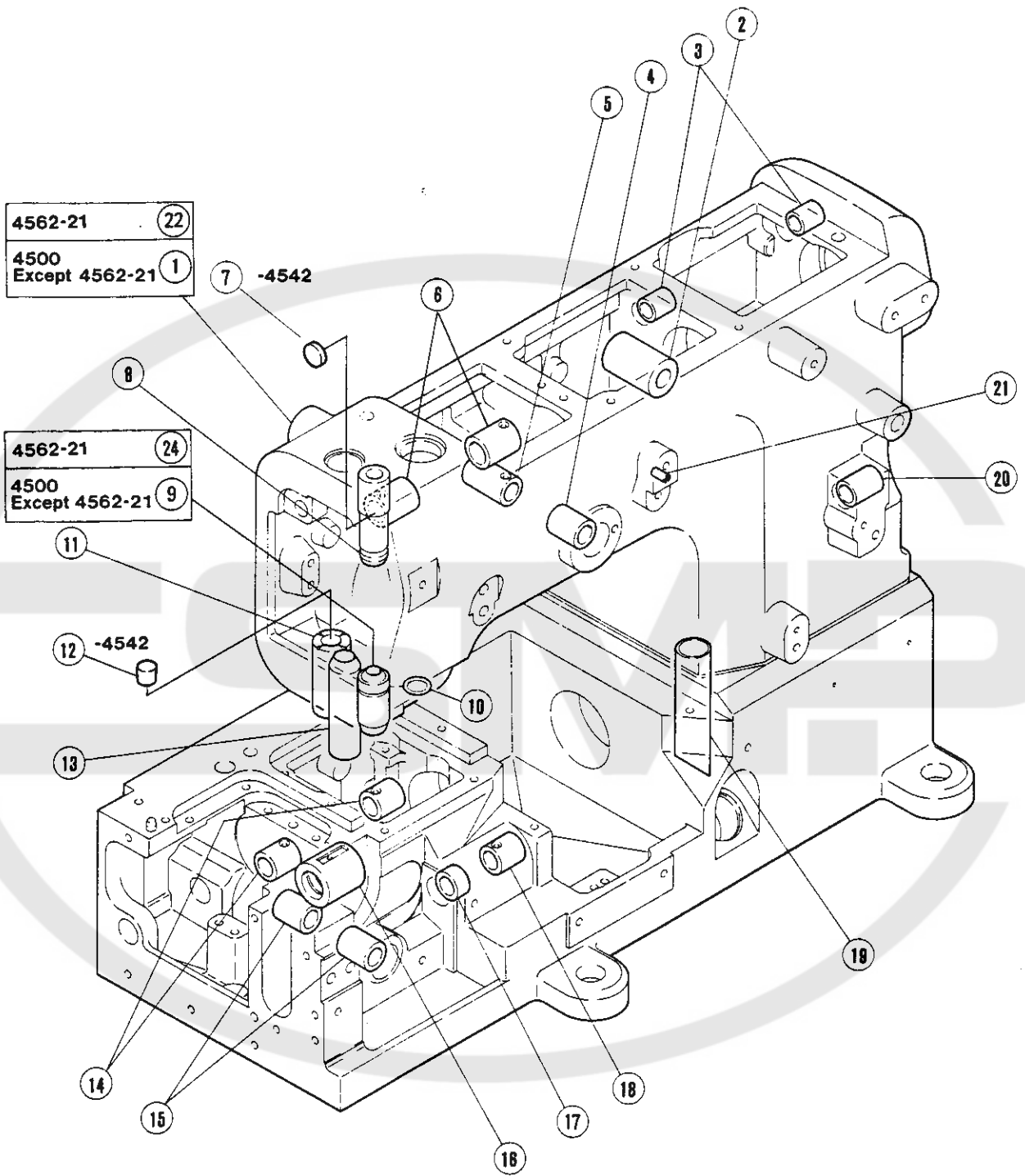

4500=4562·4542

MACHINE BED FRAME (2)

REF. NO.	PART NO.	PFAFF-NO.	NAME	QT.
* 1	250215-SD	09-009840-45	MACHINE FRAME	1
* *	250215-CD	09-009827-58	MACHINE FRAME	09 1 050790
* *	250000-CA	09-009820-21	MACHINE FRAME	09 1 100789
2	253012	09-400278-00	BUSHING	1
3	253016	09-400282-00	BUSHING	2
4	210297	09-009615-49	BUSHING	1
5	210291	09-009615-44	BUSHING	1
6	210102	09-009613-81	BUSHING	2
7	240111	09-400171-00	PLUG	1
	210003	09-009613-03	PLUG	11 1 100789
8	206059A	09-400439-00	BUSHING	1
9	251003	09-400233-00	BUSHING	1
10	240020	15-120909-05	O RING	1
11	254509	09-400329-00	BUSHING	1
12	205088	09-009604-86	PLUG	1
	206527	09-400129-00	PLUG	11 1 100789
13	253007	09-400275-00	BUSHING	1
14	252005	09-400245-00	BUSHING	2
15	210297	09-009615-49	BUSHING	2
16	250503	09-400220-00	BUSHING	1
17	208292	09-009605-76	BUSHING	1
18	252005	09-400245-00	BUSHING	1
19	255020	09-400344-00	PIPE	1
20	256015	09-400382-00	BUSHING	1
21	240108	09-400169-00	PIN	1
*22	250215ASD	09-009840-46	MACHINE FRAME	1
* *	250215ACD	09-009827-59	MACHINE FRAME	09 1 050790
* *	250000ACA	09-009820-22	MACHINE FRAME	09 1 100789
23				
* *	250061-CA	09-009820-31	MACHINE FRAME	10 1 100789
24	251003A	09-009829-27	BUSHING	1

Notice) Parts with mark * are not for sale.

12-52~58 4500
Except 4500/MD

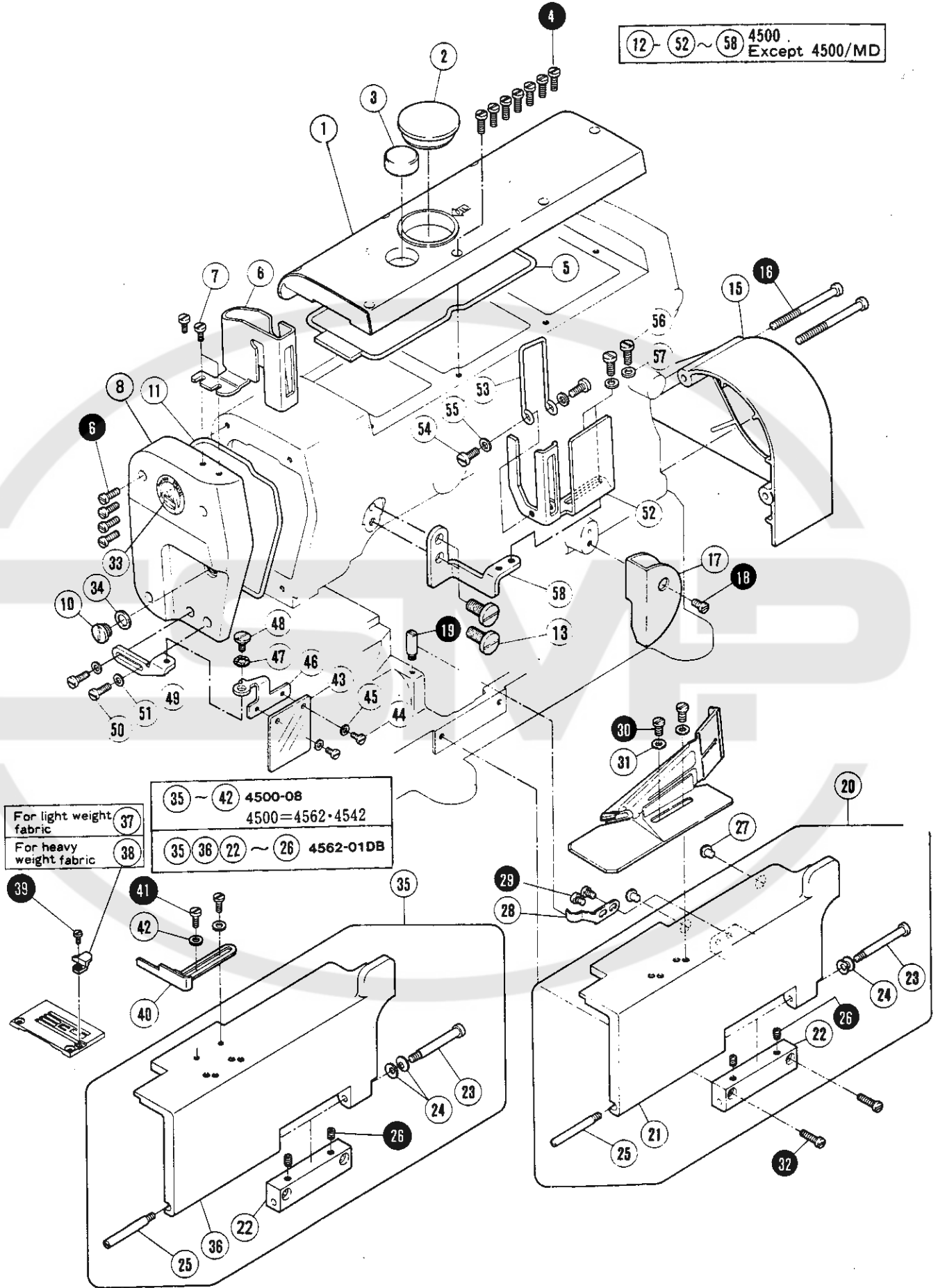

REF. NO.	PART NO.	PFAFF-NO.	NAME	QT.
1	250149AUD	09-009832-22	ARM COVER (TOP)	1
	250149ACD	09-009827-57	ARM COVER (TOP)	09 1 050790
	250018ACD	09-009820-24	ARM COVER (TOP)	09 1 100789
2	5198	09-009054-04	SCREW	1
3	179107-05	91-179107-05	OIL SIGHT WINDOW	1
4	7021	11-108180-15	SCREW	7
5	250019	09-400204-00	O RING	1
6	250224	09-009827-60	NEEDLE BAR GUARD	1
	250021-RA	09-400450-00	NEEDLE BAR COVER	09 1 100789
7	7019	11-108174-15	SCREW	2
8	250016-UD	09-009842-71	ARM COVER (LEFT)	1
	250016-BD	09-009820-23	ARM COVER (LEFT)	09 1 050790
9	7021	11-108180-15	SCREW	4
10	5242	09-009601-06	SCREW	1
11	250017	09-400203-00	O RING	1
12	250231-9S	09-009837-25	THREAD TAKEUP COVER	1
	250231-9C	09-009829-25	THREAD TAKEUP COVER	09 1 050790
	250023-UD	09-009827-52	THREAD TAKEUP COVER	09 1 777777
	250023-RA	09-400452-00	THREAD TAKEUP COVER	09 1 100789
13	7052	91-100187-15	SCREW	2
	7052	91-100187-15	SCREW	09 1
14	207924	09-400145-00	WASHER	10 1
15	250022-UB	09-009842-72	PULLEY COVER	1
	250022-BB	09-009827-51	PULLEY COVER	09 1 050790
	250022-KB	09-400451-00	PULLEY COVER	09 1 100789
16	7075	09-400081-00	SCREW	2
17	250005-UD	09-009827-49	COVER/LOOPER THREAD GUIDE	1
	250005-RA	09-400447-00	COVER/LOOPER THREAD GUIDE	09 1 100789
18	7019	11-108174-15	SCREW	1
19	7089	09-400094-00	SCREW	1
20	250032-SD	09-009836-39	FRONT COVER ASSEMBLY	1
	250032-CD	09-009827-53	FRONT COVER ASSEMBLY	09 1 050790
	250032-JD	09-400454-00	FRONT COVER ASSEMBLY	09 1 100789
*21	250011	09-400198-00	FRONT COVER	1
*22	250012	09-400199-00	HINGE	1
23	250013	09-400200-00	SCREW	1
24	201191	09-009050-43	SPRING	2
25	250014	09-400201-00	SCREW	1
26	4539	11-330217-15	SCREW	2
27	210025	09-009613-16	CUSHION	2
28	250051	09-400219-00	FLAT SPRING	1
29	7018	11-108171-15	SCREW	2
30	7034	11-173225-15	SCREW	2
31	204585	09-009602-15	WASHER	2
32	7023	11-108186-15	SCREW	2
*33	211313	09-009821-00	NAME PLATE	1
34	240263	09-009820-20	WASHER	1
35	250032BSD	09-009836-46	FRONT COVER ASSEMBLY	1
	250032BCD	09-009827-54	FRONT COVER ASSEMBLY	09 1 050790
36	250011B	09-009827-50	FRONT COVER	1
37	257571	09-009821-36	HENMING GUIDE	1
38	257572	09-009821-35	HENMING GUIDE	1
39	7120	09-009819-98	SCREW	1
40	258013-91	09-009828-62	FABRIC GUIDE	1
41	7020	11-108177-15	SCREW	2
42	303448	12-305114-15	WASHER	2
43	250257	09-009827-63	EYE GUARD	1
44	7009	11-108090-15	SCREW	2
45	202875	09-009601-76	WASHER	2
46	250256	09-009827-62	BRACKET	1
47	210307	09-009615-57	WASHER	1
48	7066	91-179529-15	SCREW	1
49	250255	09-009827-61	BRACKET	1
50	7020	11-108177-15	SCREW	2
51	303448	12-305114-15	WASHER	2
52	250225-SD	09-009832-97	THREAD TAKEUP GUARD	1
	250225-CD	09-009829-19	THREAD TAKEUP COVER	09 1 050790
53	250226	09-009829-20	FINGER GUARD	1
54	7017	11-108168-15	SCREW	2
55	303448	12-305114-15	WASHER	2
56	7018	11-108171-15	SCREW	2
57	303448	12-305114-15	WASHER	2
58	250227-SD	09-009840-47	BRACKET	1
	250227-CD	09-009829-21	BRACKET	09 1 050790

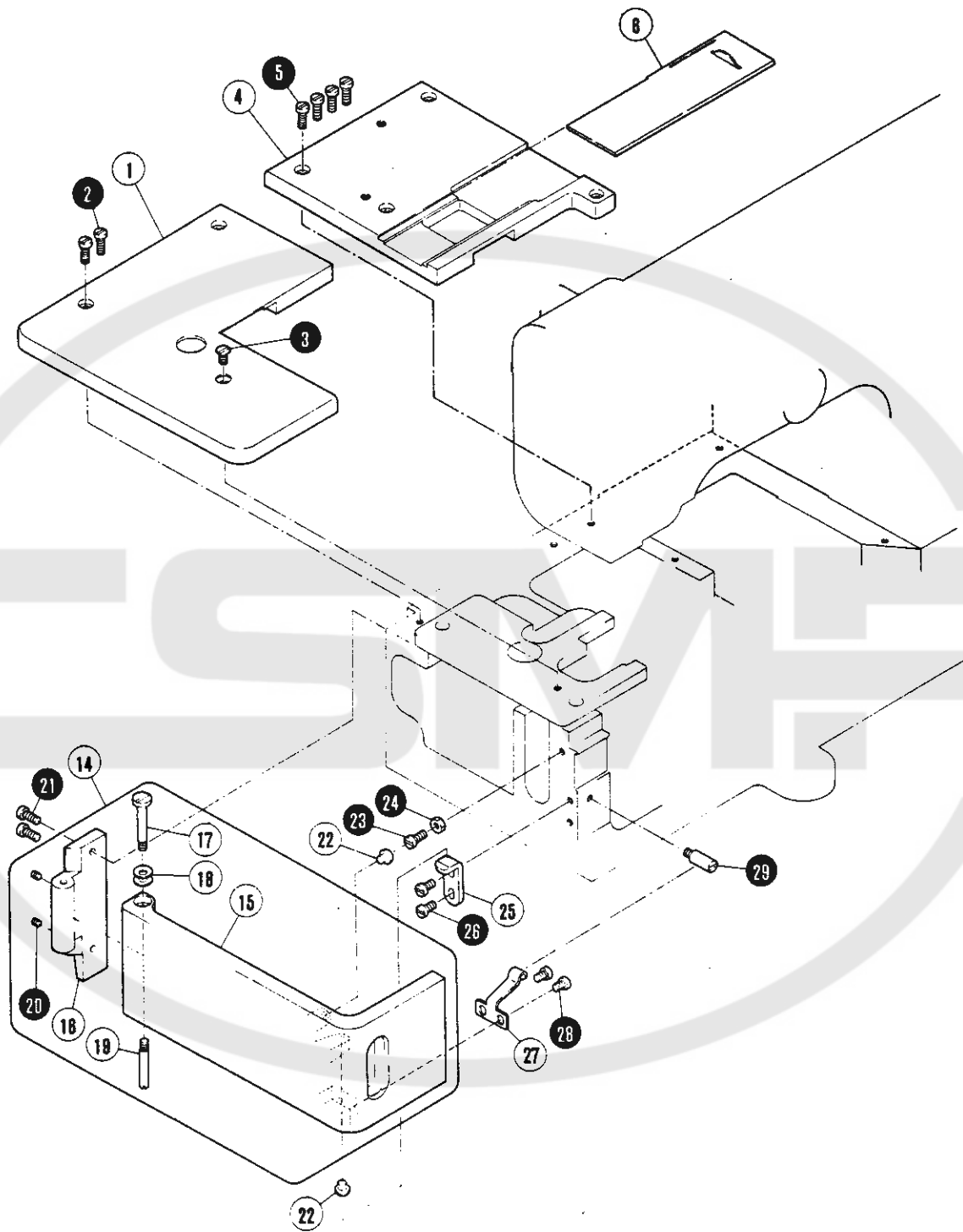

COVER (2)

REF. NO.	PART NO.	PFAFF-NO.	NAME	QT.
1	250052BSD	09-009840-40	BED COVER (LEFT)	1
	250052BCD	09-009820-30	BED COVER (LEFT)	09 1 050790
2	7021	11-108180-15	SCREW	2
3	7043	11-210168-15	SCREW	1
4	250074ASD	09-009840-43	BED COVER (RIGHT)	1
	250074ACD	09-009827-56	BED COVER (RIGHT)	09 1 050790
	250074BCD	09-009812-68	BED COVER (RIGHT)	15 1 100789
5	7021	11-108180-15	SCREW	4
6	250071-91	09-009816-80	SLIDE PLATE	1
14	250039-SD	09-009840-38	SIDE COVER COMPLETE	1
	250039-CD	09-009820-28	SIDE COVER COMPLETE	09 1 050790
*15	250035	09-400212-00	SIDE COVER	1
*16	250036	09-400213-00	HINGE	1
17	250037	09-400214-00	SCREW	1
18	201191	09-009050-43	SPRING	2
19	250038	09-400215-00	SCREW	1
20	4535	11-330085-15	SCREW	2
21	7020	11-108177-15	SCREW	2
22	210025	09-009613-16	CUSHION	2
23	7020	11-108177-15	SCREW	1
24	4821	12-024151-15	NUT	1
25	250047	09-400217-00	BRACKET	1
26	7019	11-108174-15	SCREW	2
27	206023	09-400107-00	FLAT SPRING	1
28	7018	11-108171-15	SCREW	2
29	7089	09-400094-00	SCREW	1

Notice) Parts with mark * are not for sale.

4500 Except 4500-05 4562-21	(45)
4562-21	(43)
4500-05	(1)

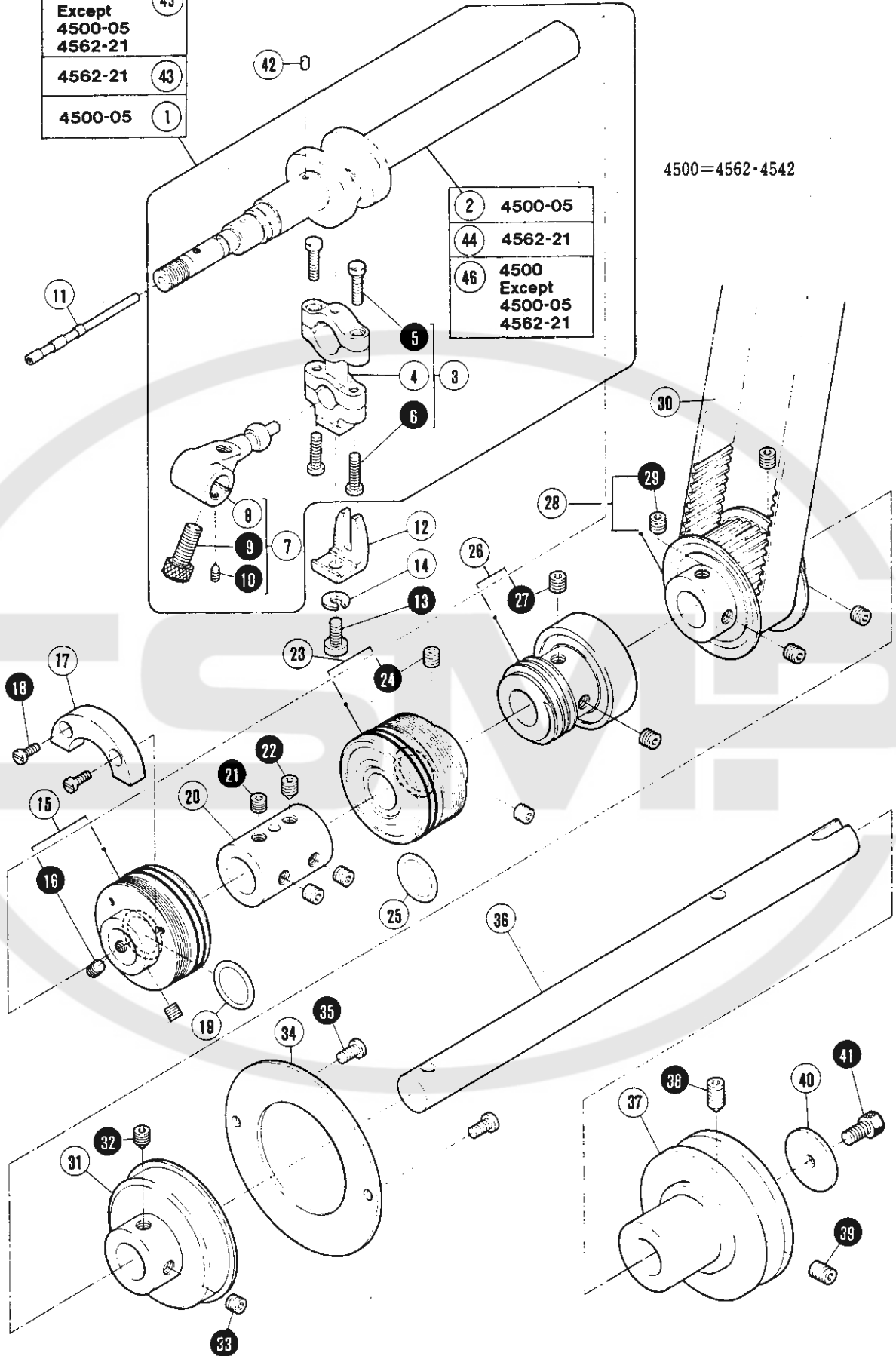

CRANKSHAFT MECHANISM

REF. NO.	PART NO.	PFAFF-NO.	NAME	QT.
1	250532-91	09-400473-00	CRANKSHAFT ASSEMBLY	1
* 2	250501-91	09-400465-00	CRANKSHAFT	1
3	252009-92	09-400482-00	CONNECTION ASSEMBLY	1
* 4	252009	09-400250-00	CONNECTION	1
5	7015	11-108144-15	SCREW	2
6	7015	11-108144-15	SCREW	2
7	252008-92	09-400481-00	CRANK ASSEMBLY	1
* 8	252008	09-400249-00	CRANK BODY	1
9	4534	11-130909-15	SCREW	1
10	4545	11-335085-15	SCREW	1
11	250525	09-400230-00	ADJUSTING BAR	1
12	201074A	09-009049-48	GUIDE	1
13	4019	09-400035-00	SCREW	1
14	201252	09-009050-73	SPRING WASHER	1
15	250504-91	09-400466-00	BUSHING	1
16	4514	11-330280-15	SCREW	2
17	250534	09-400231-00	BALANCE WEIGHT	1
18	7011	11-108096-15	SCREW	2
19	206837	09-400140-00	O RING	1
20	250506	09-009817-12	JOINT	1
21	4547	11-341901-15	SCREW	3
22	4555	09-400060-00	SCREW	1
23	250508-91	09-400467-00	BUSHING	1
24	4547	11-341901-15	SCREW	2
25	206837	09-400140-00	O RING	1
26	250543A91	09-009820-34	BUSHING	1
27	4547	11-341901-15	SCREW	2
28	250511-91	09-400468-00	GEAR (LOWER)	1
29	4547	11-341901-15	SCREW	4
30	206050C	09-009820-17	TIMING BELT	1
31	250530-91	09-400472-00	BUSHING	1
32	4555	09-400060-00	SCREW	1
33	4547	11-341901-15	SCREW	1
34	250514	09-400223-00	SET PLATE	1
35	7082	09-400088-00	SCREW	2
36	250507	09-400222-00	SHAFT	1
37	250515	09-400224-00	MACHINE PULLEY	1
38	4556	09-400061-00	SCREW	1
39	4541	11-330280-15	SCREW	1
40	240126	09-400184-00	WASHER	1
41	4500	11-130224-15	SCREW	1
42	206748	09-400139-00	FELT	1
43	250532C91	09-009827-68	CRANKSHAFT ASSEMBLY	1
	250532A91	09-009817-13	CRANKSHAFT ASSEMBLY	09 1 100789
*44	250501C91	09-009827-65	CRANKSHAFT	1
	250501A91	09-009817-14	CRANKSHAFT	09 1 100789
45	250532B91	09-009827-67	CRANKSHAFT ASSEMBLY	1
*46	250501B91	09-009827-64	CRANKSHAFT	1

Notice) Parts with mark * are not for sale.

34	4562-21
1	4500 Except 4562-21

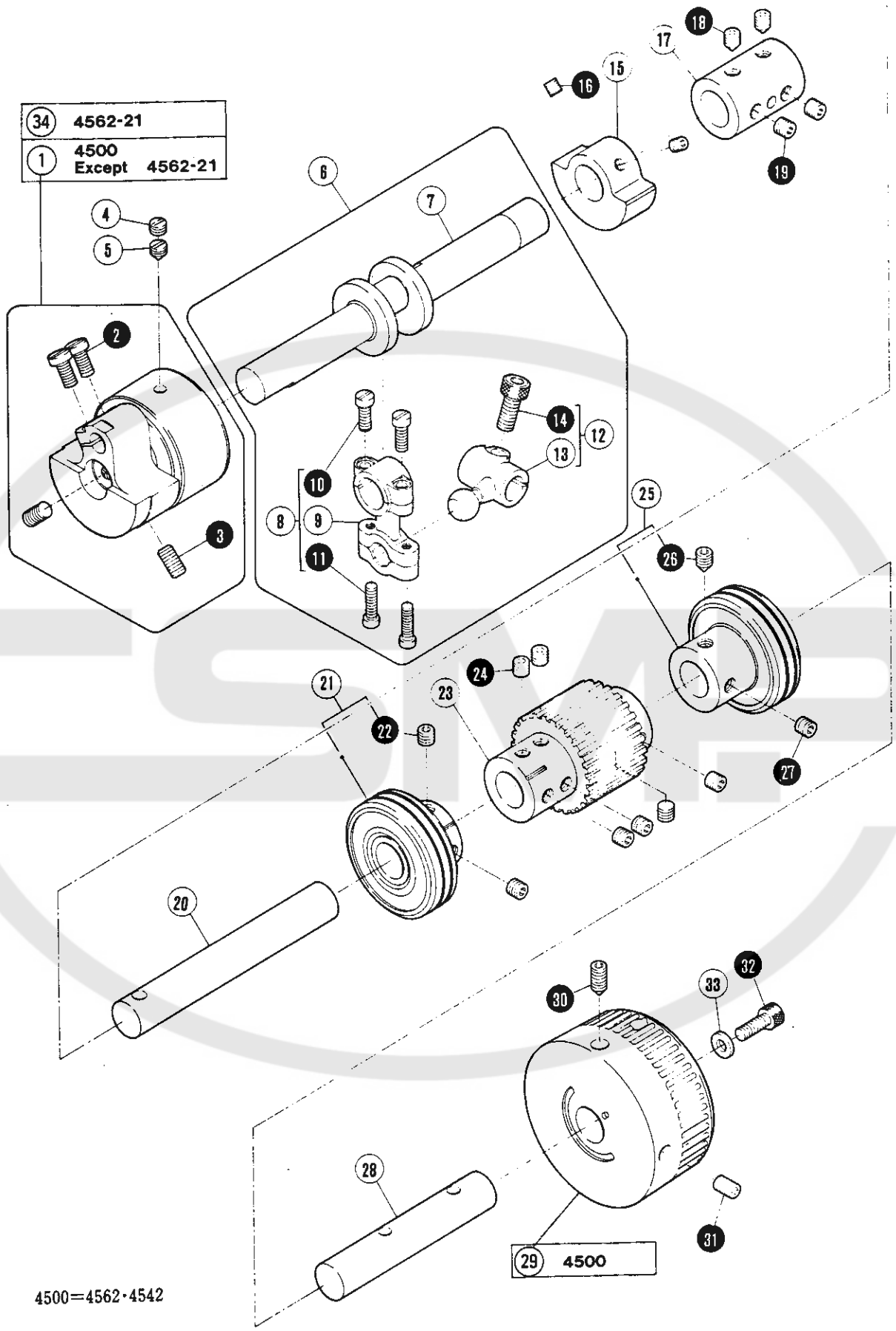

4500=4562-4542

29 4500

ARM SHAFT MECHANISM

REF. NO.	PART NO.	PFAFF-NO.	NAME	QT.
1	250526-91	09-400469-00	MOTION ASSEMBLY	1
2	7028	11-108225-15	SCREW	2
3	4542	11-330286-15	SCREW	2
4	2913-2	09-009600-20	SCREW	1
5	5058	09-009064-85	SCREW	1
6	250533-91	09-400474-00	CRANKSHAFT ASSEMBLY	1
7	250517	09-400225-00	CRANKSHAFT	1
8	253500-92	09-400493-00	CONNECTION ASSEMBLY	1
* 9	253500	09-009285-00	CONNECTION	1
10	7015	11-108144-15	SCREW	2
11	7021	11-108180-15	SCREW	2
12	253501-92	09-400494-00	CRANK ASSEMBLY	1
*13	253501	09-009286-00	CRANK	1
14	4534	11-130909-15	SCREW	1
15	250524	09-400229-00	BALANCE WEIGHT	1
16	4514	11-330280-15	SCREW	2
17	250506	09-009817-12	JOINT	1
18	4555	09-400060-00	SCREW	2
19	4547	11-341901-15	SCREW	2
20	250518	09-400226-00	SHAFT	1
21	250529-91	09-400471-00	BUSHING	1
22	4547	11-341901-15	SCREW	2
23	250521	09-400228-00	GEAR (UPPER)	1
24	4547	11-341901-15	SCREW	6
25	250528-91	09-400470-00	BUSHING	1
26	4555	09-400060-00	SCREW	1
27	4547	11-341901-15	SCREW	1
28	250519	09-400227-00	SHAFT	1
*29	250523EUD	09-009840-50	HANDWHEEL	1
	250523EBD	09-009827-66	HANDWHEEL	09 1 050790
	250523ABD	09-009820-33	HANDWHEEL	09 1 100789
30	4541	11-330280-15	SCREW	1
31	4556	09-400061-00	SCREW	1
32	4501	09-400039-00	SCREW	1
33	204585	09-009602-15	WASHER	1
34	250526A91	09-009817-15	MOTION ASSEMBLY	1

Notice) Parts with mark * are not for sale.

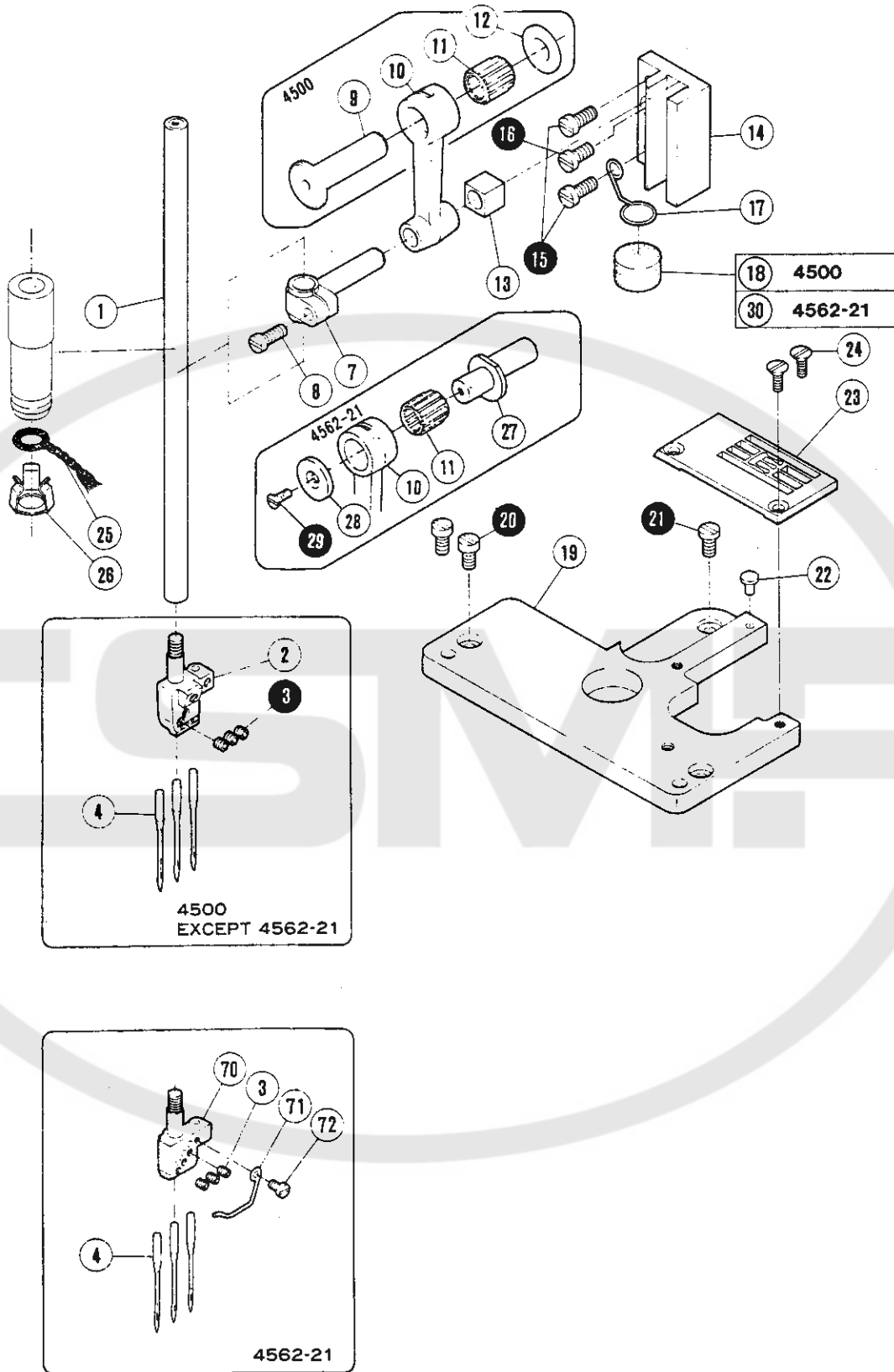

NEEDLE BAR MECHANISM

REF. NO.	PART NO.	PFAFF-NO.	NAME	QT.
1	251000-91	09-400475-00	NEEDLE BAR	1
2	XXXXXX		NEEDLE HOLDER	1
3	4554	11-330082-15	SCREW	3
* 4	UY128GAS		NEEDLE	3
5				
	251008	09-400235-00	NEEDLE THREAD GUIDE	09 1 051089
6				
	7031	11-108849-15	SCREW	09 1 051089
7	206061	09-400111-00	NEEDLE BAR CLAMP	1
8	5325	09-400069-00	SCREW	1
9	206053-2	09-400110-00	PIN	1
10	206052	09-400109-00	LINK/NEEDLE BAR DRIVE	1
11	240098	09-400165-00	NEEDLE BEARING	1
12	240101	09-400166-00	WASHER	1
13	206063	09-400113-00	GUIDE BLOCK	1
14	206062	09-400112-00	GUIDE BLOCK/NEEDLE BAR	1
15	7021	11-108180-15	SCREW	2
16	7020	11-108177-15	SCREW	1
17	251009	09-400236-00	LATCH	1
18	179040-05	91-179040-05	SPONGE	1
19	251007	09-400234-00	BRACKET	1
20	7019	11-108174-15	SCREW	2
21	7082	09-400088-00	SCREW	1
22	240123	09-400181-00	CUSHION RUBBER	1
23	XXXXXX		NEEDLE PLATE	1
24	5373-HC	09-009817-16	SCREW	2
*25	212186	09-009734-34	OIL WICK	1
	202186	09-009817-17	OIL WICK	15 1 100789
26	206524	09-400128-00	OIL WICK RETAINER	1
27	251010A-2	09-009817-18	ECCENTRIC PIN	1
28	205097	09-009817-19	WASHER	1
29	7041	09-009814-11	SCREW	1
30	251011	09-009827-69	SPONGE	1
70	XXXXXX		NEEDLE HOLDER	1
71	251008	09-400235-00	NEEDLE THREAD GUIDE	1
72	7031	11-108849-15	SCREW	1

Notice) Parts with mark * are not for sale.

See pages 60~104 for ×××××.

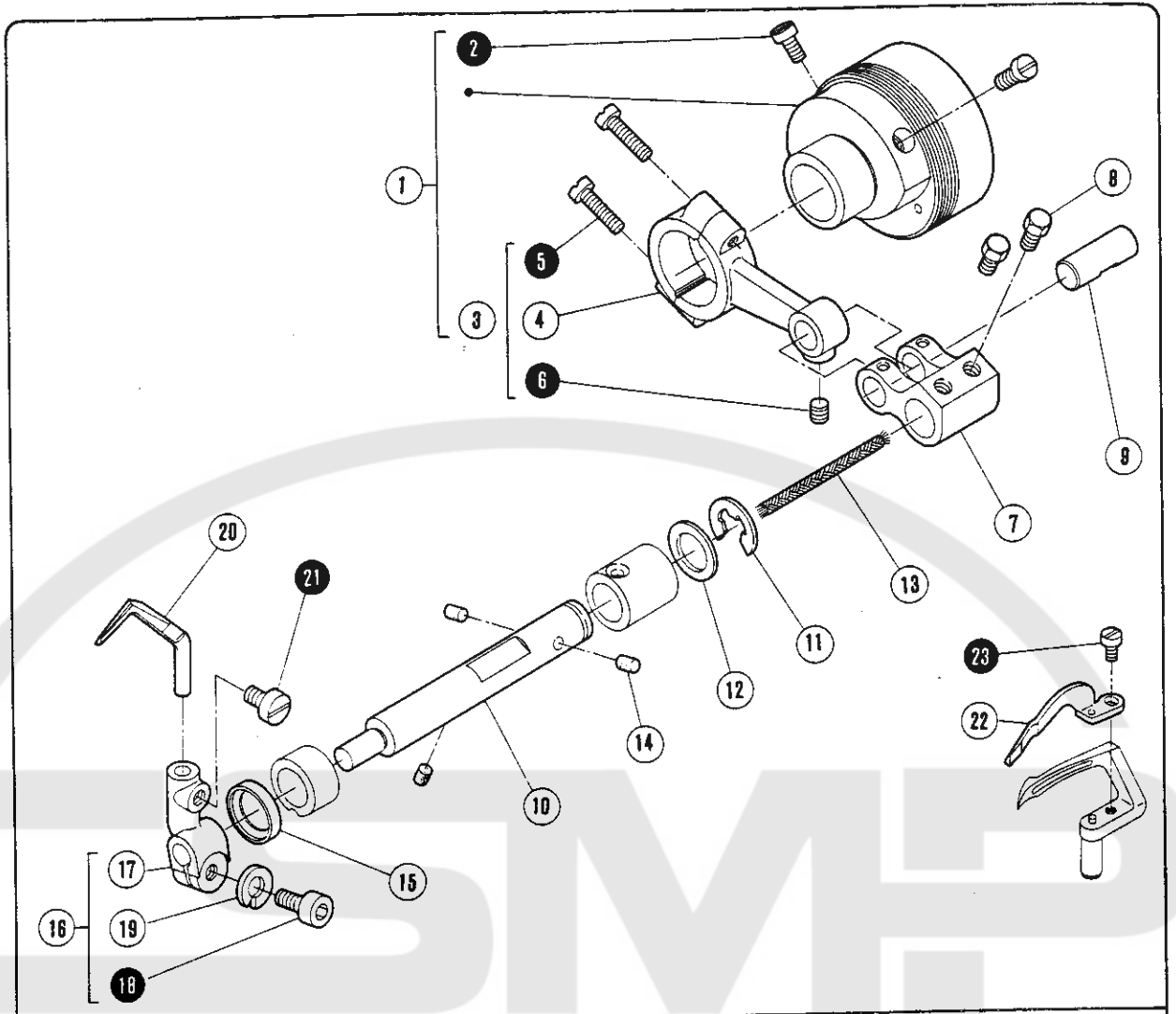

4500-05

4500=4562·4542

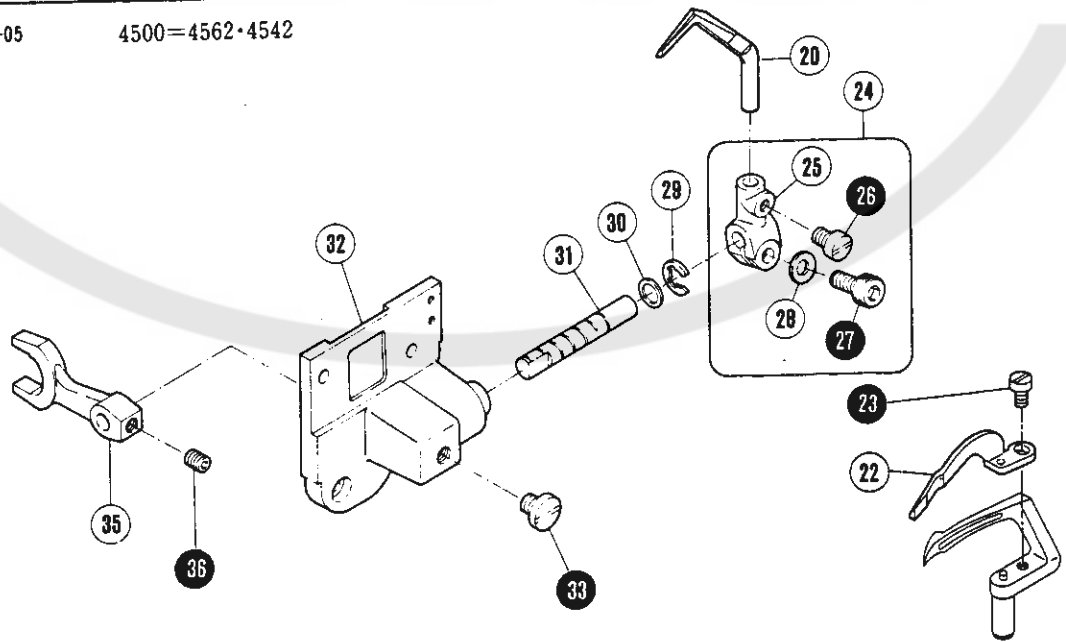

NEEDLE GUARD MECHANISM

REF. NO.	PART NO.	PFAFF-NO.	NAME	QT.
1	251517-91	09-009827-70	ECCENRTIC/CONNECTION ASSEMBLY	1
2	4539	11-330217-15	SCREW	2
3	255501-92	09-400512-00	CONNECTION ASSEMBLY	1
* 4	255501	09-400360-00	CONNECTION	1
5	7015	11-108144-15	SCREW	2
6	4543	11-330955-15	SCREW	1
7	306093	09-400413-00	CRANK	1
8	5084	09-009053-76	SCREW	2
9	205495-2	09-009603-81	PIN	1
10	251518	09-009827-71	SHAFT	1
11	205061	12-640200-55	RING	1
12	240102	09-400167-00	WASHER	1
*13	202176	26-536302-09	OIL WICK	1
14	206748	09-400139-00	FELT	3
15	204052A	09-009064-62	OIL SEAL	1
16	251519-92	09-009827-73	LEVER ASSEMBLY	1
*17	251519	09-009827-72	LEVER	1
18	4500	11-130224-15	SCREW	1
19	303067	12-501170-45	SPRING WASHER	1
20	XXXXXX		NEEDLE GUARD (REAR)	1
21	7017	11-108168-15	SCREW	1
22	XXXXXX		NEEDLE GUARD (FRONT)	1
23	7031	11-108849-15	SCREW	1
24	251505-92	09-400477-00	LEVER ASSEMBLY	1
*25	251505	09-400239-00	LEVER	1
26	7017	11-108168-15	SCREW	1
27	4500	11-130224-15	SCREW	1
28	303067	12-501170-45	SPRING WASHER	1
29	200983	12-640170-55	RING	1
30	207924	09-400145-00	WASHER	1
31	251503	09-400237-00	SHAFT	1
32	251500-91	09-400476-00	BRACKET	1
33	7081	09-400087-00	SCREW	1
34	7019	11-108174-15	SCREW	09 3 100789
*35	251504	09-400238-00	LEVER	1
36	4514	11-330280-15	SCREW	1

Notice) Parts with mark * are not for sale.

See pages 60~104 for ×××××

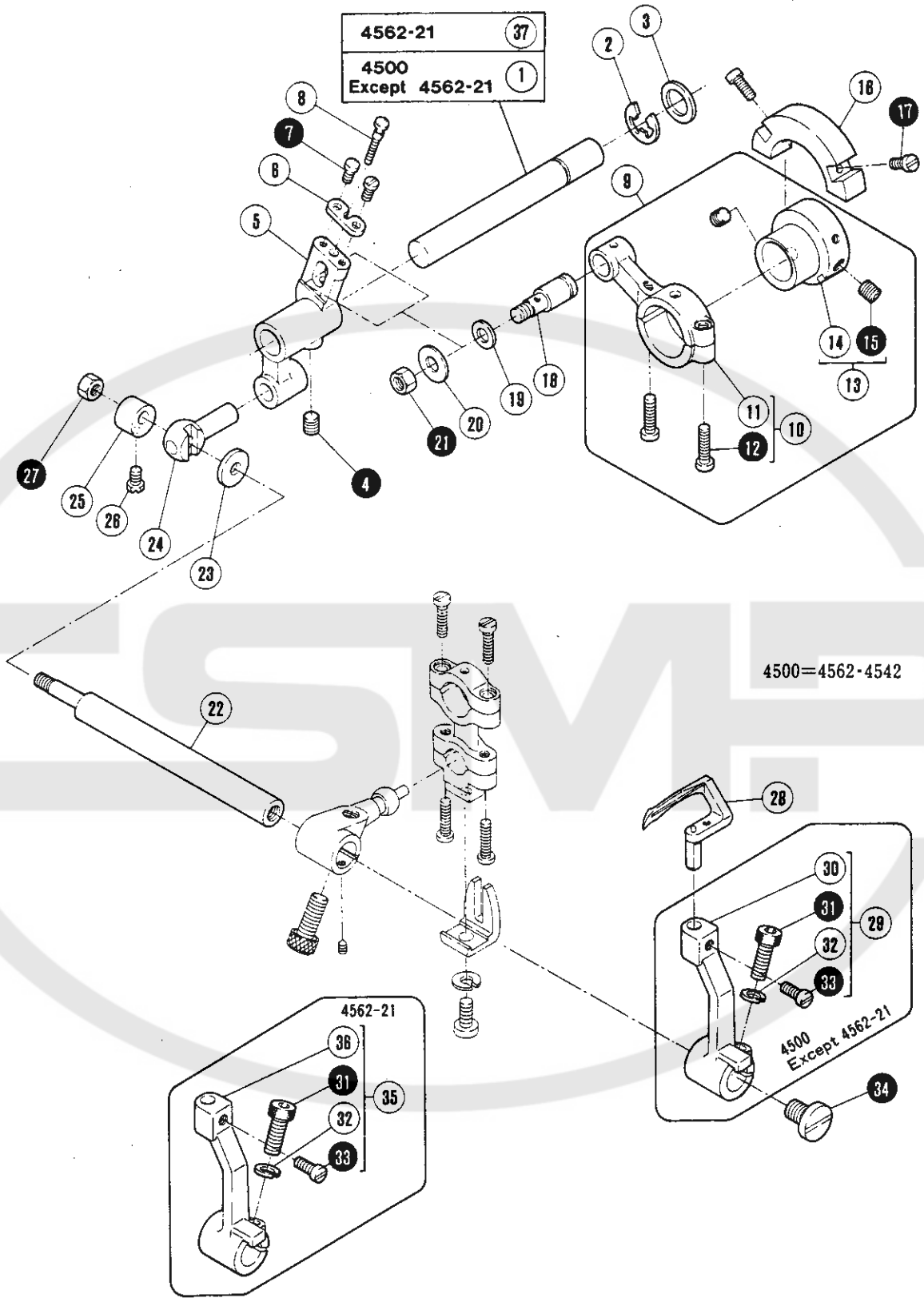

LOOPER MECHANISM

REF. NO.	PART NO.	PFAFF-NO.	NAME	QT.
1	252004	09-400244-00	SHAFT	1
2	205061	12-640200-55	RING	1
3	240102	09-400167-00	WASHER	1
4	4539	11-330217-15	SCREW	1
5	252002	09-400242-00	CRANK	1
6	179402-05	91-179402-05	GUIDE PLATE	1
7	7032	11-108855-15	SCREW	2
8	179403-15	91-179403-15	SCREW	1
9	252011-91	09-400483-00	ECCENTRIC-CONNECTION ASSEMBLY	1
10	252001-92	09-400479-00	CONNECTION ASSEMBLY	1
*11	252001	09-400241-00	CONNECTION	1
12	7015	11-108144-15	SCREW	2
13	252000-92	09-400478-00	ECCENTRIC ASSEMBLY	1
*14	252000	09-400240-00	ECCENTRIC	1
15	4539	11-330217-15	SCREW	2
16	252010	09-400251-00	BALANCE WEIGHT	1
17	7011	11-108096-15	SCREW	2
18	179399-05	91-179399-05	PIN	1
19	240062	91-179509-05	WASHER	1
20	240049	91-179400-05	WASHER	1
21	4805	09-400065-00	NUT	1
22	252006	09-400247-00	SHAFT	1
23	208028	09-009606-17	WASHER	1
24	252003	09-400243-00	BLOCK PIN	1
25	208029	09-009606-18	COLLAR	1
26	5084	09-009053-76	SCREW	1
27	4802	09-400064-00	NUT	1
28	XXXXXX		LOOPER	1
29	252007-92	09-400480-00	LOOPER HOLDER ASSEMBLY	1
*30	252007	09-009848-00	LOOPER HOLDER	1
31	4501	09-400039-00	SCREW	1
32	303067	12-501170-45	SPRING WASHER	1
33	7086	09-400092-00	SCREW	1
34	7085	09-400091-00	SCREW	1
35	252007A92	09-009817-20	LOOPER HOLDER ASSEMBLY	1
*36	252007A	09-009817-21	LOOPER HOLDER	1
37	252004A	09-009829-28	SHAFT	1

Notice) Parts with mark * are not for sale.

See pages 60~104 for XXXXXX.

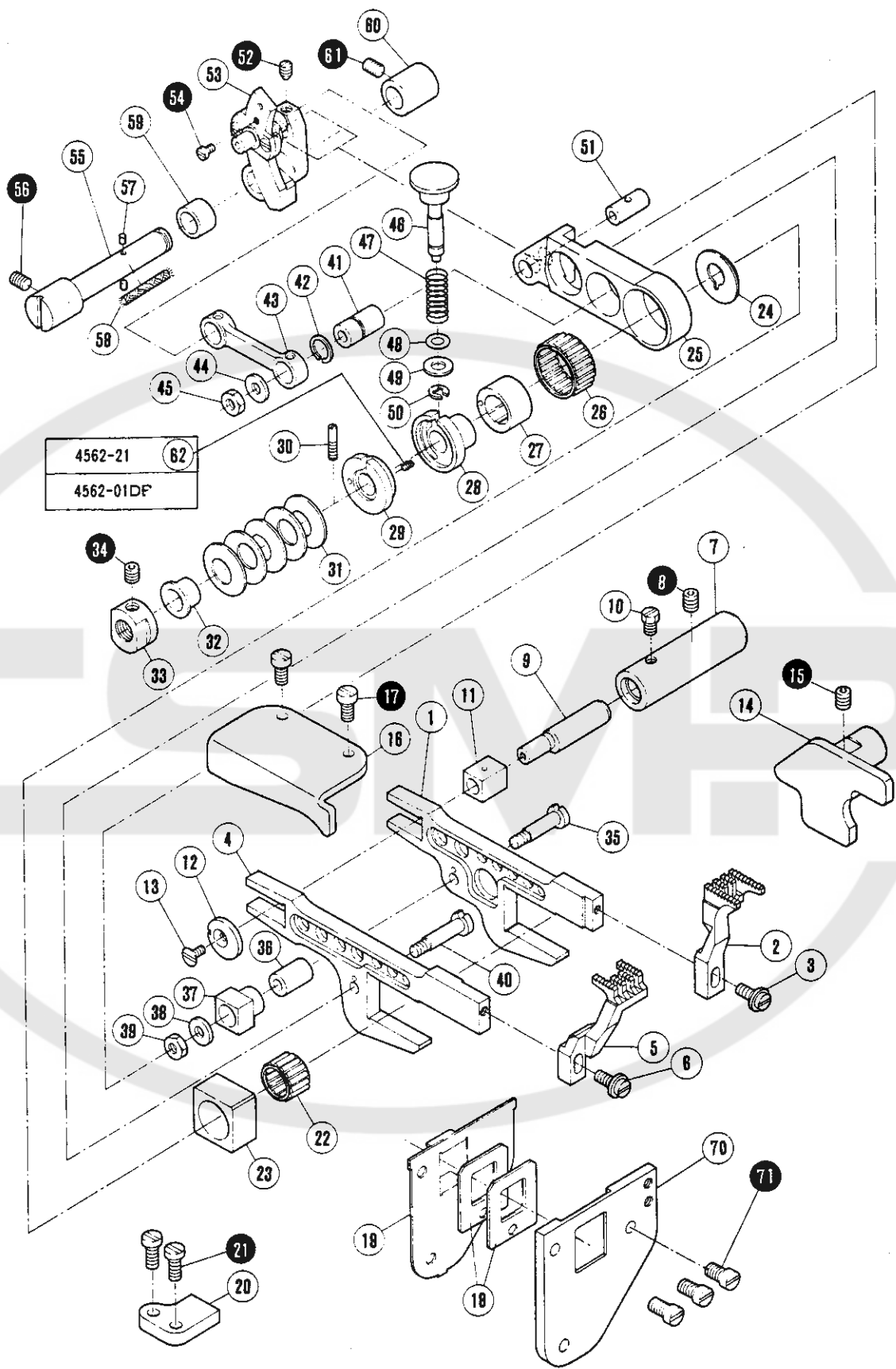

FEED MECHANISM(1)

REF. NO.	PART NO.	PFAFF-NO.	NAME	QT.
1	252500-91	09-400484-00	MAIN FEED BAR	1
2	XXXXXX		MAIN FEED DOG	1
3	5590	09-009734-83	SCREW	1
4	252502-91	09-400485-00	DIFFERENTIAL FEED BAR	1
5	XXXXXX		DIFFERENTIAL FEED DOG	1
6	5590	09-009734-83	SCREW	1
7	204129A	09-009601-84	BUSHING	1
8	4539	11-330217-15	SCREW	1
9	204128A	09-009601-83	PIN	1
10	5084	09-009053-76	SCREW	1
11	205857	09-400106-00	BLOCK/FEED BAR GUIDE	1
12	204439A	09-009602-09	WASHER	1
13	5317	09-009601-17	SCREW	1
14	252504	09-400252-00	GUIDE (RIGHT)	1
15	4539	11-330217-15	SCREW	1
16	252507	09-400253-00	GUIDE (LEFT)	1
17	7019	11-108174-15	SCREW	2
18	206133	09-400115-00	OIL SHIELD	2
19	252509	09-400255-00	COVER	1
20	252508	09-400254-00	GUIDE (LOWER)	1
21	7020	11-108177-15	SCREW	2
22	206128-2	09-009612-90	NEEDLE BEARING	1
23	252519	09-400258-00	BLOCK	1
24	252520	09-400259-00	WASHER	1
25	206562	09-400130-00	LINK/MAIN FEED	1
26	206125-2	09-400114-00	NEEDLE BEARING	1
27	252521	09-400260-00	ECCENTRIC	1
28	252522	09-400261-00	REGULATOR	1
29	252523-91	09-400486-00	ECCENTRIC RETAINER	1
30	252516	09-400257-00	SCREW	1
31	240125	09-400183-00	SPRING	5
32	252525	09-400262-00	SPACER	1
33	252543	09-400272-00	NUT	1
34	4514	11-380280-15	SCREW	1
35	206120	09-009070-56	SCREW	1
36	206119	09-009070-55	BUSHING	1
37	206563	09-400131-00	GUIDE BLOCK	1
38	200098	09-009048-70	WASHER	1
39	3044	09-009053-49	NUT	1
40	206123	09-009070-58	SCREW	1
41	206566	09-400134-00	BUSHING	1
42	206565	09-400133-00	RING	1
43	206564	09-400132-00	DIFFERENTIAL FEED LINK	1
44	200098	09-009048-70	WASHER	1
45	3044	09-009053-49	NUT	1
46	252526	09-400263-00	PIN	1
47	240122	09-400180-00	SPRING	1
48	206366	09-400125-00	O RING	1
49	204585	09-009602-15	WASHER	1
50	200555	09-009071-03	RING	1
51	206569	09-400135-00	PIN	1
52	4546	11-335166-15	SCREW	1
53	252527-91	09-400487-00	CRANK	1
54	7031	11-108849-15	SCREW	1
55	252510	09-400256-00	SHAFT	1
56	4539	11-330217-15	SCREW	1
57	207358	09-400144-00	OIL FELT	2
*58	202175	09-009601-64	OIL WICK	1
59	240119	09-400179-00	SPACER	1
60	206571	09-400136-00	BUSHING	1
61	4539	11-330217-15	SCREW	1
62	7080	09-400086-00	SCREW	1

Notice) Parts with mark * are not for sale.

See pages 60~104 for ×××××.

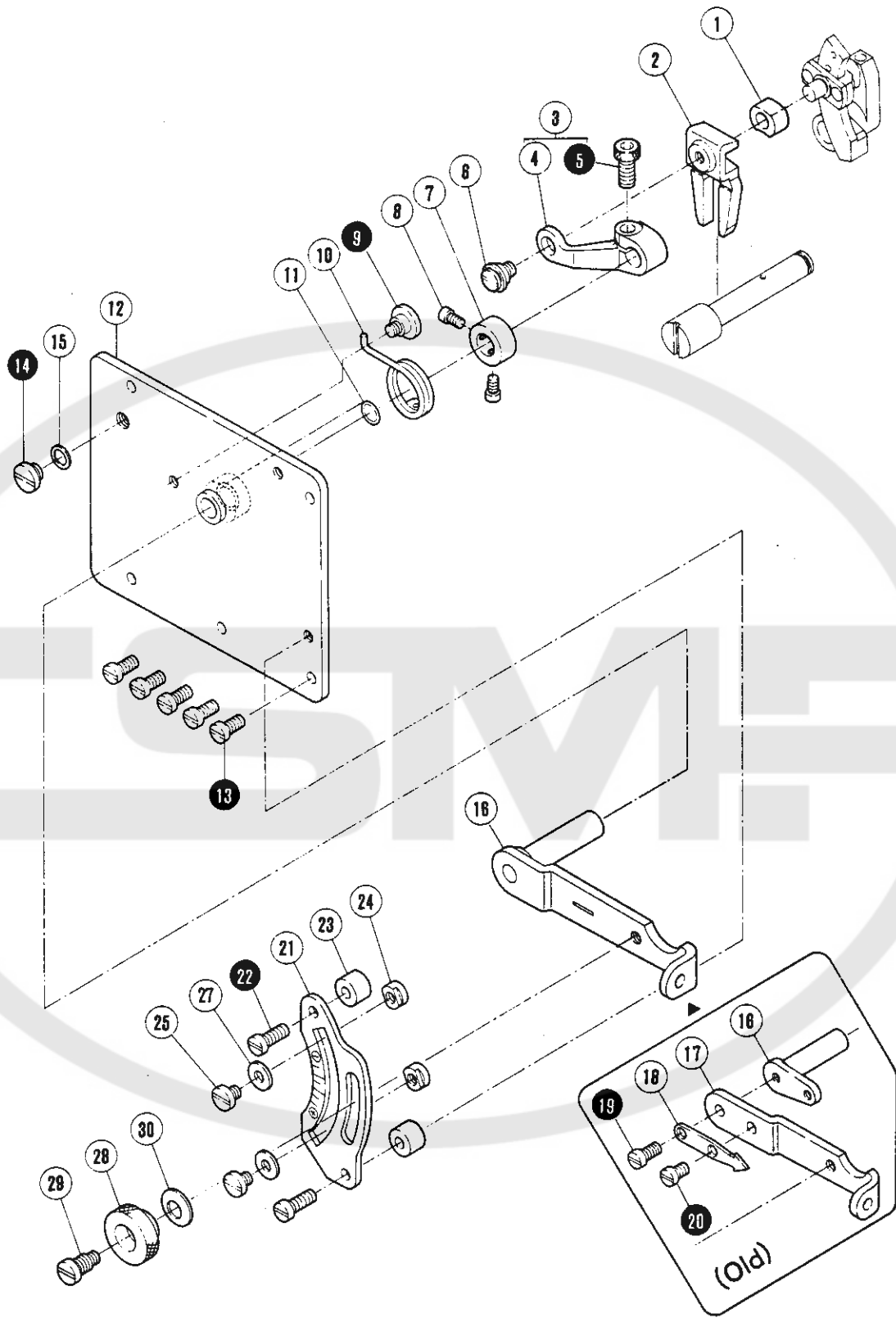

FEED MECHANISM (2)

REF. NO.	PART NO.	PFAFF-NO.	NAME	QT.	
1	252531	09-400264-00	BLOCK	1	
2	252532	09-400265-00	GUIDE/BLOCK	1	
3	252533-92	09-400488-00	LEVER	1	
* 4	252533	09-400266-00	LEVER	1	
5	4531	11-130227-15	SCREW	1	
6	5316	09-009601-16	SCREW	1	
7	240271	09-009827-48	COLLAR	1	
	232508	09-400156-00	COLLAR	01	1 100789
8	1998-2	09-009048-69	SCREW	2	
9	7066	91-179529-15	SCREW	1	
10	252536	09-400269-00	SPRING	1	
11	240129	09-400186-00	O RING	1	
12	252539-91	09-400489-00	BRACKET	1	
13	7019	11-108174-15	SCREW	5	
14	7081	09-400087-00	SCREW	1	
15	200138	09-009066-59	GASKET	1	
16	252664-91	09-009827-74	LEVER ASSEMBLY	1	
* 17	252534	09-400267-00	SHAFT	02	1 051089
* 18	252535	09-400268-00	LEVER	10	1 051089
* 19	252537	09-400270-00	INDICATOR	10	1 051089
20	7013	11-108135-15	SCREW	10	1 051089
	7013	11-108135-15	SCREW	10	1 051089
* 21	7092	09-400095-00	SCREW	09	1 050888
22	252538	09-400271-00	SCALE PLATE	1	
23	7021	11-108180-15	SCREW	2	
24	240124	09-400182-00	SPACER	2	
25	210171	09-009614-41	STOPPER	2	
26	2905	09-009823-33	SCREW	2	
27	201191	09-009050-43	SPRING	10	2 071089
	201185	09-009050-38	WASHER	2	
28	210167	09-009614-38	THUMB NUT	1	
29	5486	09-009612-53	SCREW	1	
30	211301	12-305174-15	SPRING	1	

Notice) Parts with mark * are not for sale.

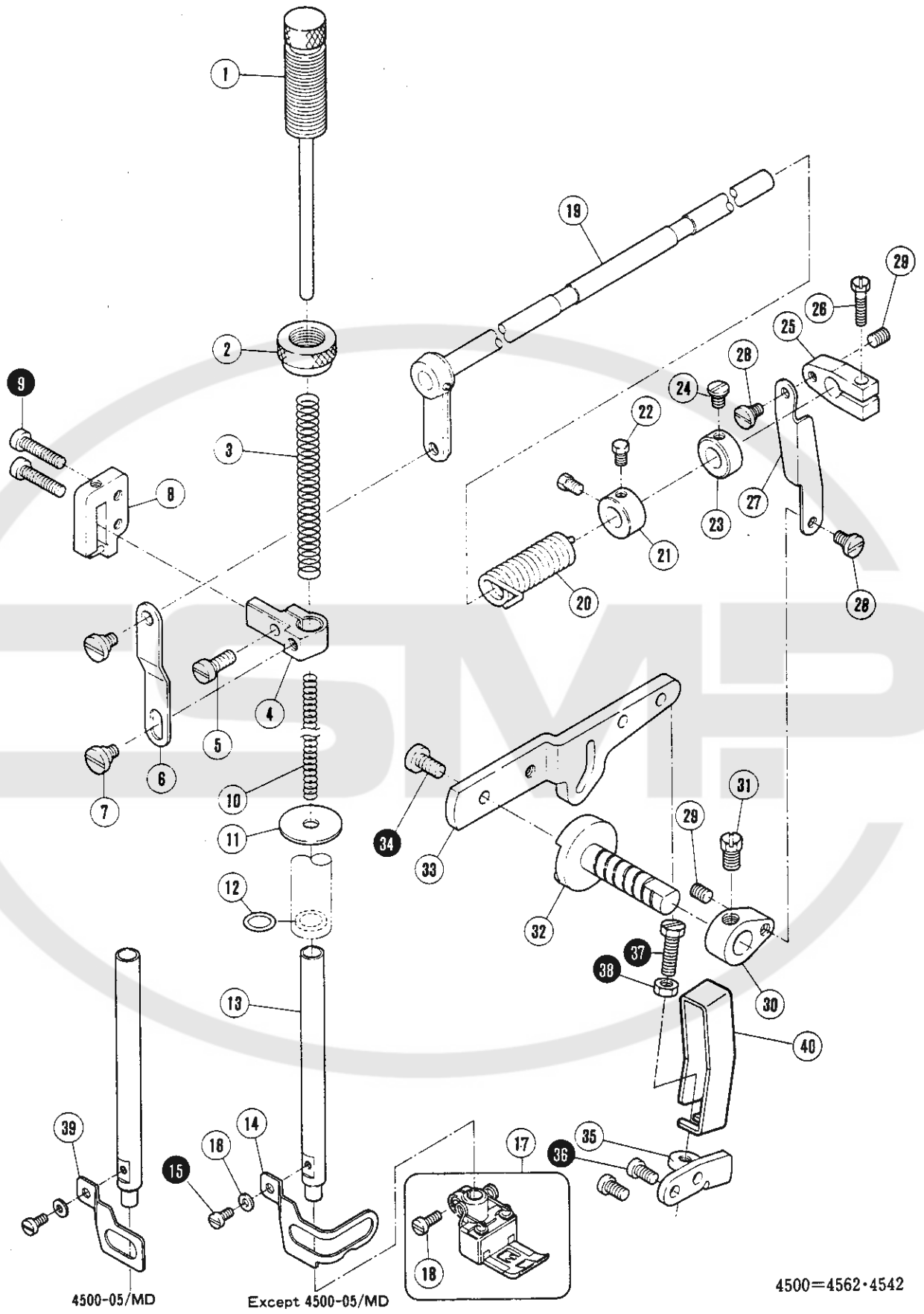

PRESSER FOOT MECHANISM

REF. NO.	PART NO.	PFAFF-NO.	NAME	QT.
1	253000-91	09-400490-00	ADJUSTING BAR	1
2	253003	09-400273-00	NUT	1
3	240112	09-400172-00	SPRING	1
4	206139	09-400116-00	PRESSER BAR CLAMP	1
5	5118	09-009053-89	SCREW	1
6	206157	09-400120-00	LINK	1
7	5386	09-400070-00	SCREW	2
8	253005-91	09-400491-00	GUIDE	1
9	7025	11-108192-15	SCREW	2
10	240113	09-400173-00	SPRING	1
11	253018	09-400284-00	OIL GUARD	1
12	240095	09-400163-00	O RING	1
13	253004	09-400274-00	PRESSER BAR	1
14	253028	09-400283-00	FINGER GUARD	1
*	253017	09-400283-00	FINGER GUARD	09 1 100489
15	7010	11-108093-15	SCREW	1
16	202875	09-009601-76	WASHER	1
17	XXXXXX		PRESSER FOOT ASSEMBLY	1
18	1170-3	09-009054-62	SCREW	1
19	253008-91	09-400492-00	LEVER	1
20	253010	09-400276-00	SPRING	1
21	206156	09-400119-00	COLLAR	1
22	5084	09-009053-76	SCREW	2
23	192024	09-400098-00	COLLAR	1
24	W00030-1	09-400001-00	SCREW	1
25	206149	09-400118-00	BELL CRANK (UPPER)	1
26	5187	09-009601-05	SCREW	1
27	253011	09-400277-00	LINK	1
28	5184	09-009054-02	SCREW	2
29	1457	09-009048-64	SCREW	2
30	206148	09-400117-00	BELL CRANK (LOWER)	1
31	2022-4	09-009051-78	SCREW	1
32	253013	09-400279-00	SHAFT	1
33	253014	09-400280-00	LEVER	1
34	7034	11-173225-15	SCREW	1
35	253015	09-400281-00	BRACKET	1
36	7019	11-108174-15	SCREW	2
37	4549	91-179367-15	SCREW	1
38	4805	09-400065-00	NUT	1
39	253029	09-009824-30	FINGER GUARD	1
40	250230-RA	09-009829-24	GUARD/ FOOT LIFT LEVER	1

Notice) Parts with mark * are not for sale.

See pages 60-104 for x x x x x.

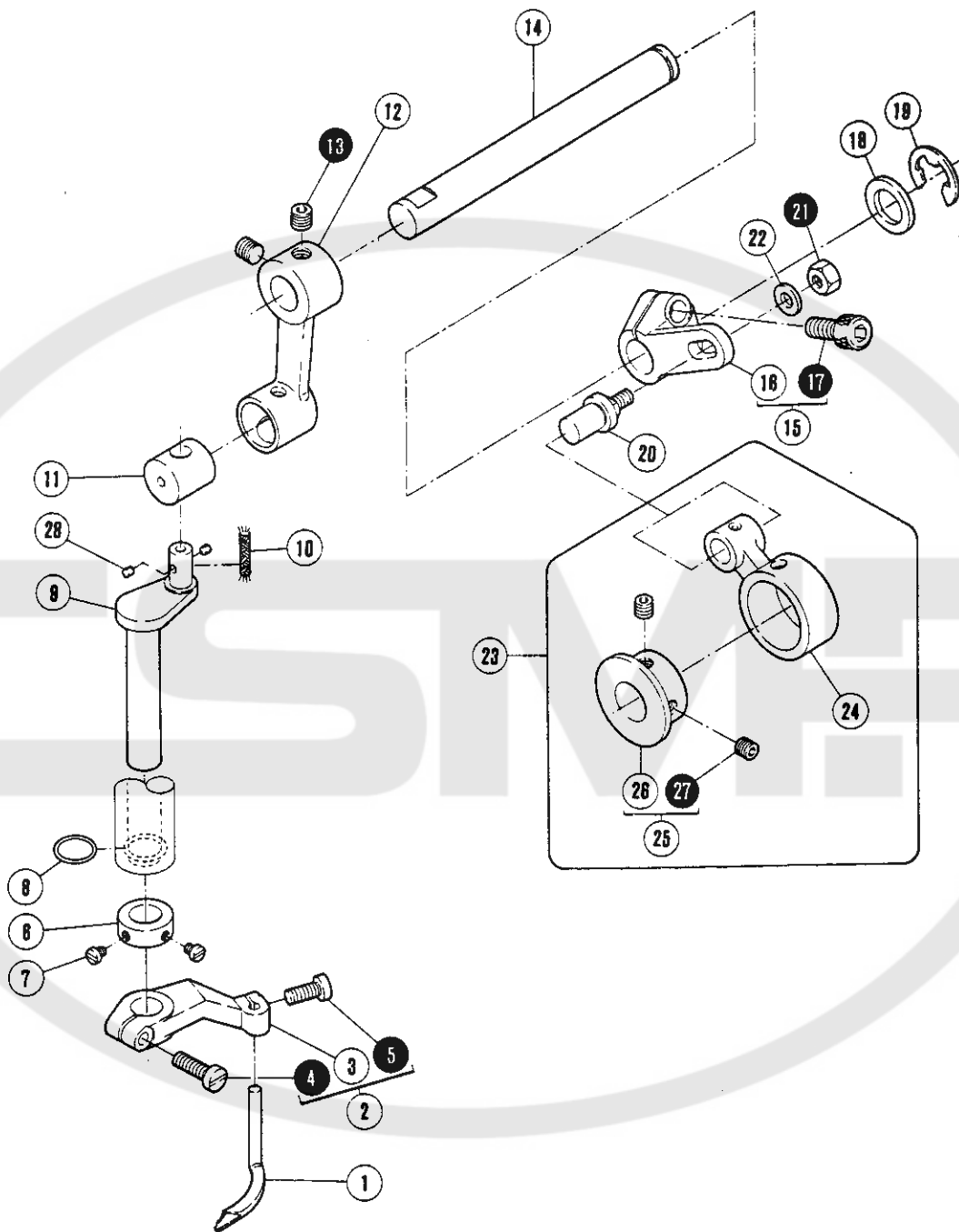

SPREADER MECHANISM

REF. NO.	PART NO.	PFAFF-NO.	NAME	QT.
1	257565	09-009826-28	SPREADER	1
	257552	09-400404-00	SPREADER	09 1 100789
2	254516-92	09-009826-48	LEVER ASSEMBLY	1
	254510-92	09-400506-00	LEVER ASSEMBLY	09 1 100789
* 3	254516	09-009827-80	LEVER	1
	254510	09-400330-00	LEVER	09 1 100789
4	7022	11-108183-15	SCREW	1
5	7020	11-108177-15	SCREW	1
6	212039	09-400152-00	COLLAR	1
7	1227	09-009804-05	SCREW	2
8	233020	09-400158-00	O RING	1
9	254508	09-400328-00	CRANKSHAFT	1
*10	202176	26-536302-09	OIL WICK	1
11	254507	09-400327-00	BLOCK	1
12	254506	09-400326-00	CRANK	1
13	4547	11-341901-15	SCREW	2
14	254519	09-009827-81	SHAFT	1
	254505	09-400325-00	SHAFT	09 1 100789
15	254503-92	09-400505-00	CRANK ASSEMBLY	1
*16	254503	09-400323-00	CRANK	1
17	4534	11-130909-15	SCREW	1
18	201635	09-009051-55	COLLAR	1
19	5048	09-009053-61	SCREW	2
20	254504	09-400324-00	SCREW	1
21	4805	09-400065-00	NUT	1
22	240062	91-179509-05	WASHER	1
23	254500-91	09-400503-00	ECCENTRIC CONNECTION ASSEMBLY	1
24	254511	09-400331-00	CONNECTION	1
25	254501-92	09-400504-00	ECCENTRIC ASSEMBLY	1
*26	254501	09-009322-00	ECCENTRIC	1
27	4514	11-330280-15	SCREW	2
28	207925	09-400146-00	FELT	2

Notice) Parts with mark * are not for sale.

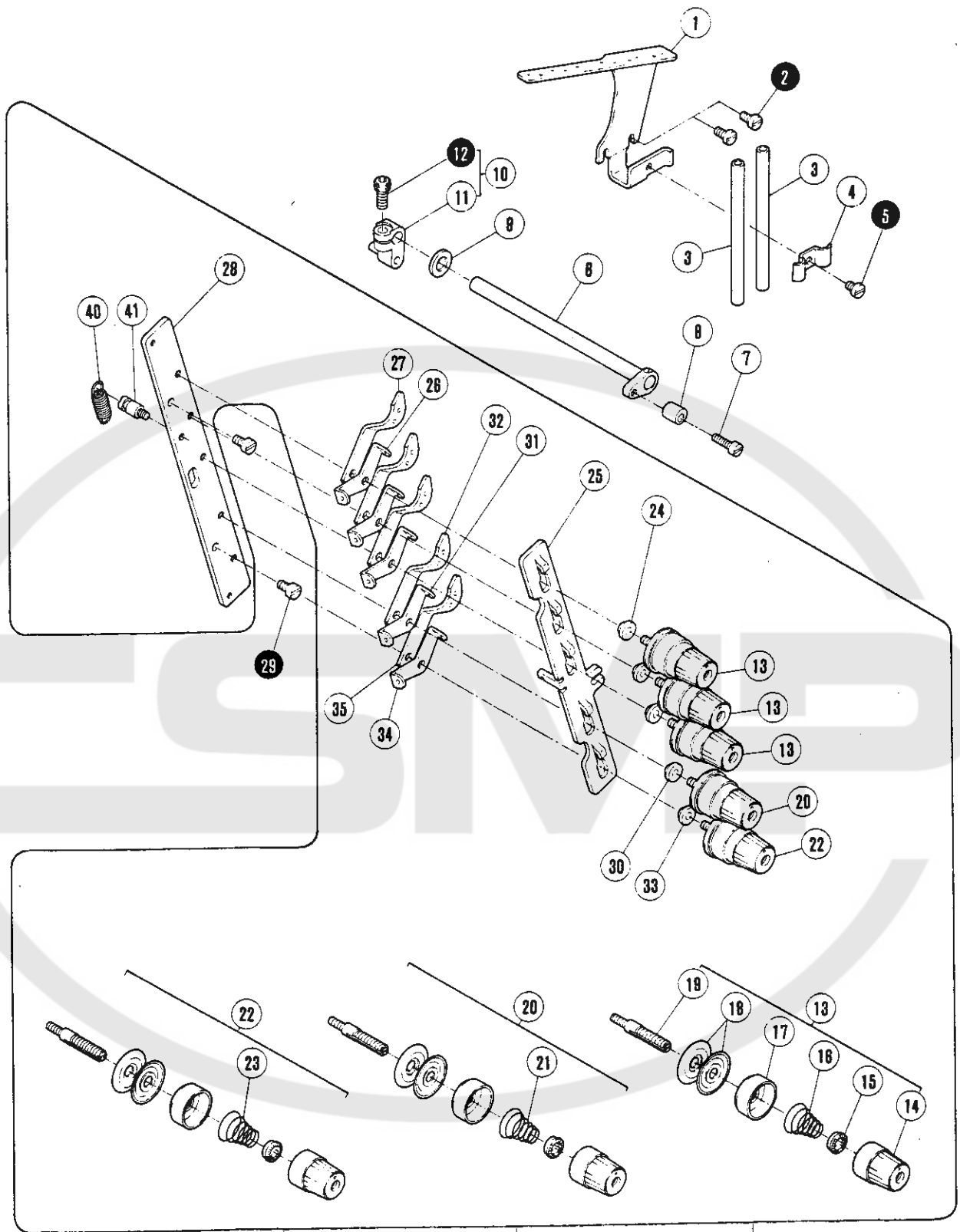

- 36 25, 28, 13 × 2, 22
 (24, 26, 27) × 2
 33 ~ 35, 3

2-Needle
 Without top cover thread.

- 37 25, 28, 13 × 2, 20
 22, (24, 26, 27) × 2
 30 ~ 35, 3 × 2

2-Needle
 With top cover thread.

- 38 25, 28, 13 × 3, 22
 (24, 26, 27) × 3
 33 ~ 35, 3

3-Needle
 Without top cover thread.

- 39 25, 28, 13 × 3, 20
 22, (24, 26, 27) × 3
 30 ~ 35, 3 × 2

3-Needle
 With top cover thread.

THREAD TENSION MECHANISM

REF. NO.	PART NO.	PFAFF-NO.	NAME	QT.
1	254008	09-400320-00	THREAD GUIDE	1
2	7019	11-108174-15	SCREW	2
3	192120	09-400099-00	PIPE	2
4	254009	09-400321-00	LATCH	1
5	7017	11-108168-15	SCREW	1
6	254000-91	09-400497-00	LEVER	1
7	2133-1	09-009053-36	SCREW	1
	5612	09-400074-00	SCREW	09 1 100789
8	254022	09-009827-99	COLLAR	1
	240118	09-400178-00	CUSHION RUBBER	09 1 100789
9	202868	09-009069-58	WASHER	1
10	254003-91	09-400498-00	CRANK	1
*11	254004	09-400288-00	CRANK	1
12	4531	11-130227-15	SCREW	1
13	254010A9U	09-009835-38	THREAD TENSION COMPLETE	
	254010A9B	09-009822-40	THREAD TENSION COMPLETE	09 1 050790
	254010A91	09-400500-00	THREAD TENSION COMPLETE	09 1 100789
14	208447-UA	09-009826-29	POST NUT	1
	208447-BA	09-009607-58	POST NUT	09 1 050790
	208447	09-009813-81	POST NUT	09 1 100789
15	208448	09-009607-59	SPRING BUSHING	1
16	201037	09-009049-22	SPRING (HEAVY)	1
17	208450-UA	09-009831-64	CUP	1
	208450-BA	09-009607-61	CUP	09 1 050790
	208450	09-009813-82	CUP	09 1 100789
18	210319	09-009615-68	TENSION DISC	2
19	1817-2A	09-400438-00	SCREW STUD	1
20	254010B9U	09-009835-39	THREAD TENSION COMPLETE	
	254010B9B	09-009827-94	THREAD TENSION COMPLETE	09 1 050790
	254010B91	09-400501-00	THREAD TENSION COMPLETE	09 1 100789
21	201086	09-009049-57	SPRING (MEDIUM)	1
22	254010C9U	09-009835-40	THREAD TENSION COMPLETE	1
	254010C9B	09-009827-95	THREAD TENSION COMPLETE	09 1 050790
	254010C91	09-400502-00	THREAD TENSION COMPLETE	09 1 100789
23	201068	09-009049-44	SPRING (LIGHT)	1
24	206202	09-400122-00	TENSION POST COLLAR	3
25	254021	09-009827-98	THREAD RELEASER	1
	254006	09-400319-00	THREAD RELEASER	09 1 100789
26	254020	09-009827-97	THREAD GUIDE	3
	206201	09-400121-00	TENSION GUIDE	09 3 100789
27	206203	09-400123-00	THREAD GUIDE	3
28	254019	09-009827-96	BRACKET	1
	254005	09-400318-00	BRACKET	09 1 100789
29	7019	11-108174-15	SCREW	2
30	206202	09-400122-00	TENSION POST COLLAR	1
31	254020	09-009827-97	THREAD GUIDE	1
	206201	09-400121-00	TENSION GUIDE	09 1 100789
32	206203	09-400123-00	THREAD GUIDE	1
33	206202	09-400122-00	TENSION POST COLLAR	1
34	254020	09-009827-97	THREAD GUIDE	1
	206201	09-400121-00	TENSION GUIDE	09 1 100789
35	206203	09-400123-00	THREAD GUIDE	1
36	254023B9U	09-009835-41	TENSION CONTROL MECHANISM	1
	254023E9B	09-009827-76	TENSION CONTROL MECHANISM	09 1 050790
	254013B91	09-009817-24	TENSION CONTROL MECHANISM	09 1 100789
37	254023C9U	09-009835-42	TENSION CONTROL MECHANISM	1
	254023C9B	09-009827-77	TENSION CONTROL MECHANISM	09 1 050790
	254013C91	09-009817-25	TENSION CONTROL MECHANISM	09 1 100789
38	254023D9U	09-009835-43	TENSION CONTROL MECHANISM	1
	254023D9B	09-009827-78	TENSION CONTROL MECHANISM	09 1 050790
	254013D91	09-009817-26	TENSION CONTROL MECHANISM	09 1 100789
39	254023E9U	09-009835-44	TENSION CONTROL MECHANISM	1
	254023E9B	09-009827-79	TENSION CONTROL MECHANISM	09 1 050790
	254013E91	09-009817-27	TENSION CONTROL MECHANISM	09 1 100789
40	306301	09-009826-60	SPRING	1
41	5447	09-009826-61	SCREW	1

Notice) Parts with mark * are not for sale.

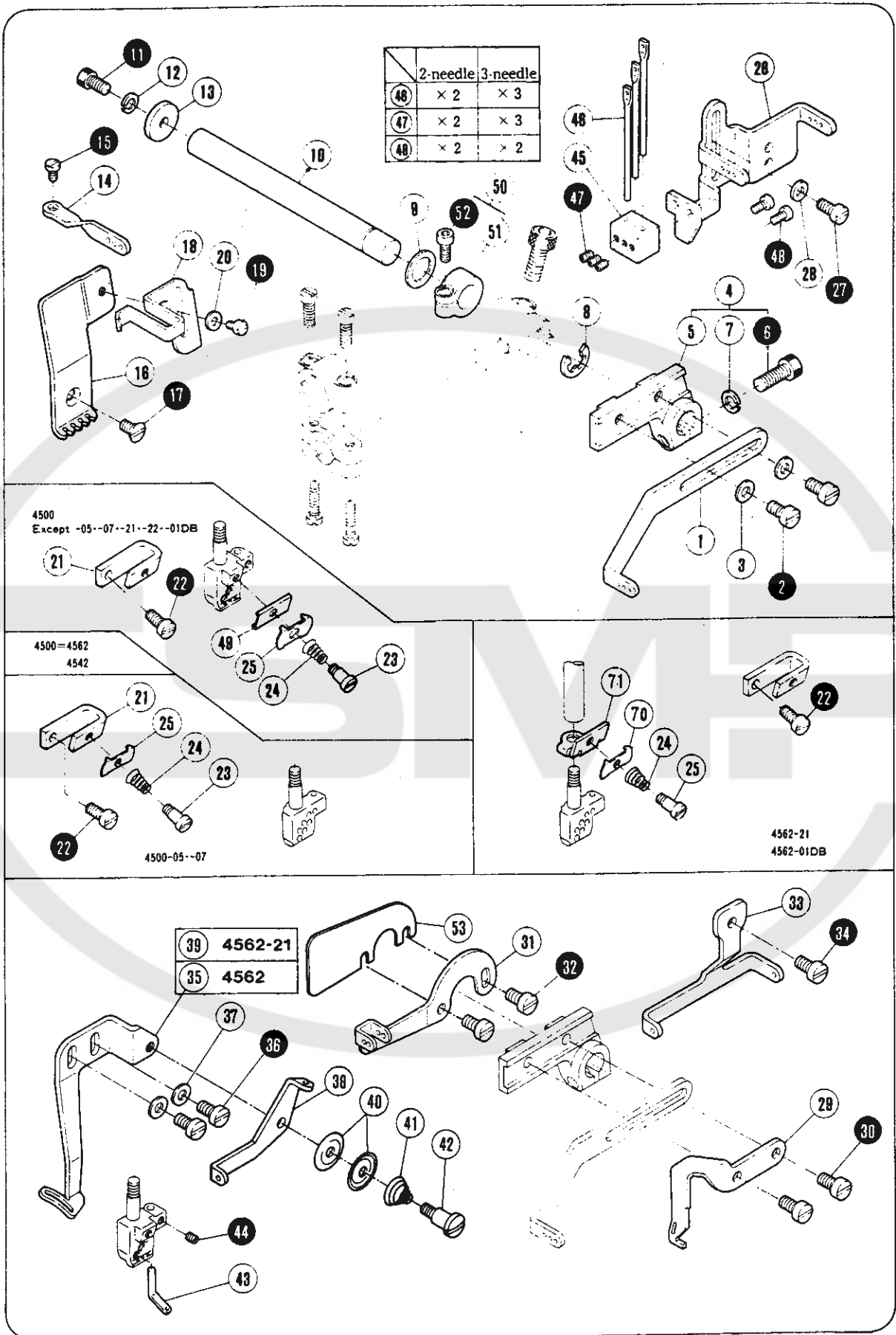

NEEDLE-SPREADER THREAD HANDLING

REF. NO.	PART NO.	PFAFF-NO.	NAME	QT.
1	253505A	09-009817-28	THREAD TAKEUP	1
2	7019	11-108174-15	SCREW	2
3	303448	12-305114-15	WASHER	2
4	253504-92	09-400495-00	LEVER	1
* 5	253504	09-400288-00	LEVER	1
6	4501	09-400039-00	SCREW	1
7	303067	12-501170-45	SPRING WASHER	1
8	205061	12-640200-55	RING	1
9	240102	09-400167-00	WASHER	1
	210122	09-009613-99	SPACER	09 1 100789
10	253503	09-400287-00	SHAFT	1
11	4527	11-130173-15	SCREW	1
12	201252	09-009050-73	SPRING WASHER	1
13	204107	09-009067-58	WASHER	1
14	253507	09-400291-00	THREAD GUIDE	1
15	7009	11-108090-15	SCREW	1
16	253508A	09-009827-75	THREAD GUIDE	1
	253508	09-400292-00	THREAD GUIDE	09 1 100987
17	7077	09-400083-00	SCREW	1
18	253509A	09-009817-29	THREAD SUPPORT	1
19	7009	11-108090-15	SCREW	1
20	202588	09-009052-70	WASHER	1
21	253516	09-400300-00	THREAD GUIDE BRACKET	1
22	7019	11-108174-15	SCREW	1
23	W09070-2	09-009054-35	SCREW	1
24	253517	09-400301-00	SPRING	1
25	253593	09-009825-69	TENSION DISC	1
	192070	09-009048-79	TENSION DISC	09 1 100987
26	253544	09-009817-30	THREAD GUIDE	1
27	7019	11-108174-15	SCREW	1
28	303448	12-305114-15	WASHER	1
29	253506	09-400290-00	THREAD TAKEUP	1
30	7019	11-108174-15	SCREW	1
31	253514	09-400298-00	THREAD GUIDE	1
32	7019	11-108174-15	SCREW	2
33	253515	09-400299-00	THREAD GUIDE	1
34	7019	11-108174-15	SCREW	1
35	253548	09-009817-31	THREAD GUIDE	1
	253512	09-400296-00	THREAD GUIDE	11 1 ??????
36	7019	11-108174-15	SCREW	2
37	303448	12-305114-15	WASHER	2
38	253513	09-400297-00	THREAD GUIDE	1
39	253548A	09-009817-33	THREAD GUIDE/SPREADER	1
	211387	09-009733-00	TENSION POST	11 1 ??????
40	137108	09-400096-00	TENSION DISC	2
*41	253539	09-009817-39	SPRING	1
	253508	09-400292-00	THREAD GUIDE	11 1 ??????
42	5526	09-400072-00	NUT	1
43	253511	09-400295-00	THREAD GUIDE	1
44	4554	11-330082-15	SCREW	1
45	253545	09-009817-35	HOLDER	1
46	234521	09-009817-36	THREAD GUIDE	1
47	4535	11-330085-15	SCREW	1
48	7010	11-108093-15	SCREW	1
49	253584B	09-009820-35	BRACKET	1
50	240201-92	09-009827-46	COLLAR	1
*51	240201	09-009827-45	COLLAR	1
52	7110	09-009827-40	SCREW	1
53	250229	09-009829-23	GUARD/ THREAD TAKEUP LEVER	1
70	192070	09-009048-79	TENSION DISC	1
71	253584B	09-009820-35	BRACKET	1

Notice) Parts with mark * are not for sale.

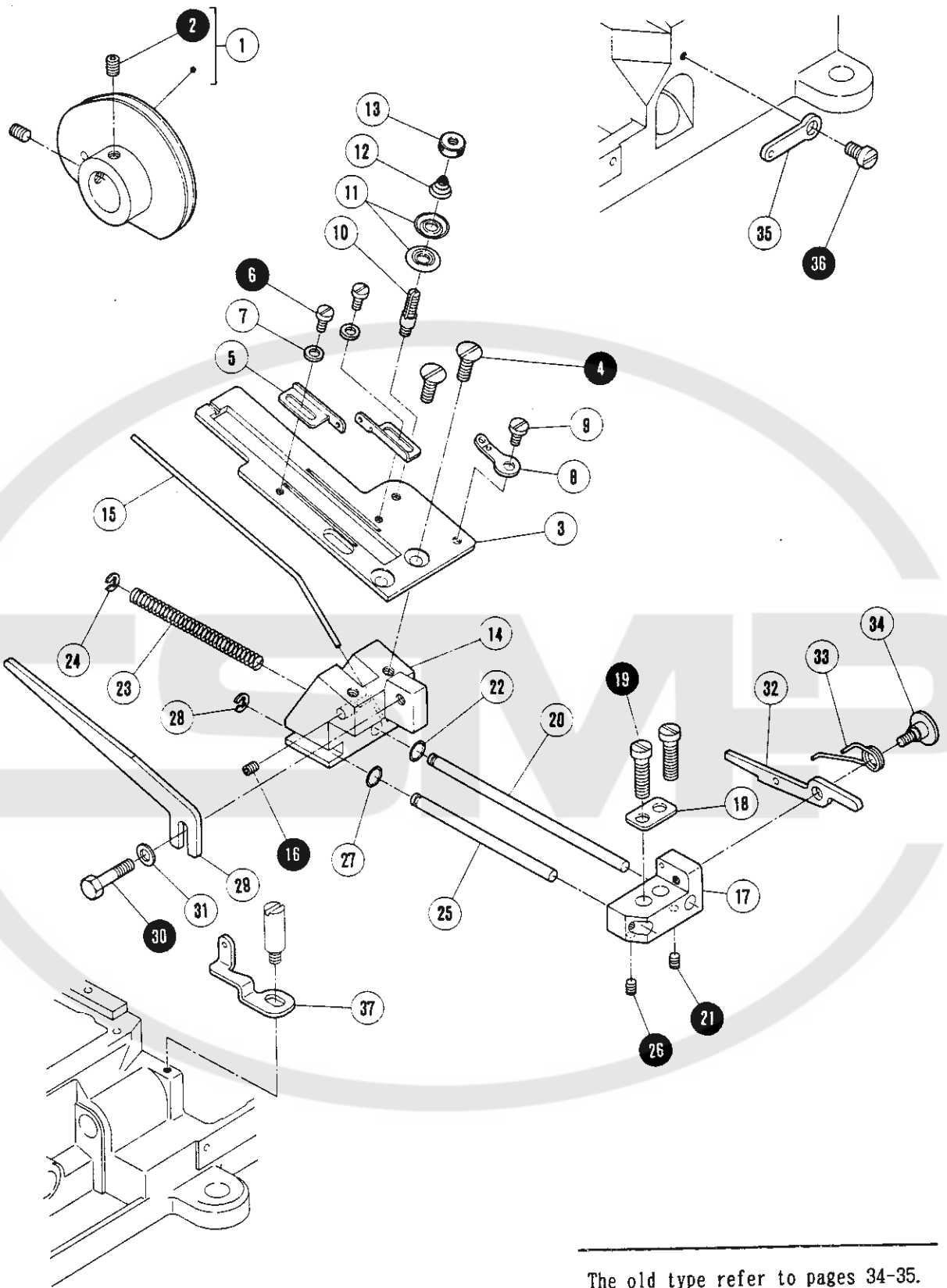

The old type refer to pages 34-35.

LOOPER THREAD HANDLING

REF. NO.	PART NO.	PFAFF-NO.	NAME	QT.
1	253608-91	09-009827-88	THREAD TAKEUP	1
2	4514	11-380280-15	SCREW	2
3	253611	09-009827-89	BRACKET	1
4	7043	11-210168-15	SCREW	2
5	253533A	09-009827-87	THREAD GUIDE	2
6	7031	11-108849-15	SCREW	2
7	210585	09-009617-43	WASHER	2
8	210353	09-009615-97	THREAD GUIDE	1
9	2921	09-009053-46	SCREW	1
10	306328	09-009828-65	TENSION POST	1
11	137108	09-400096-00	TENSION DISC	2
12	211388	91-179419-05	SPRING	1
13	5526	09-400072-00	NUT	1
14	253612	09-009827-90	BRACKET	1
15	253613	09-009827-91	THREAD SUPPORT	1
16	4554	11-330082-15	SCREW	1
17	253524	09-009825-81	BRACKET	1
18	210955A	09-009817-41	WASHER	1
19	7023	11-108186-15	SCREW	2
20	253525	09-400305-00	SHAFT	1
21	4554	11-330082-15	SCREW	1
*22	232507	09-400155-00	O RING	1
23	240115	09-400175-00	SPRING	1
24	200555	09-009071-03	RING	1
25	253526	09-400306-00	SHAFT	1
26	4554	11-330082-15	SCREW	1
*27	232507	09-400155-00	O RING	1
28	200555	09-009071-03	RING	1
29	253614	09-009827-92	THREAD GUIDE	1
30	4325	11-039171-15	SCREW	1
31	303448	12-305114-15	WASHER	1
32	253527	09-400307-00	STOPPER	1
33	253528	09-400308-00	SPRING	1
34	7087	09-400093-00	SCREW	1
35	253536	09-400315-00	THREAD GUIDE	1
36	7018	11-108171-15	SCREW	1
37	253615	09-009827-93	THREAD GUIDE	1

Notice) Parts with mark * are not for sale.

OLD TYPE

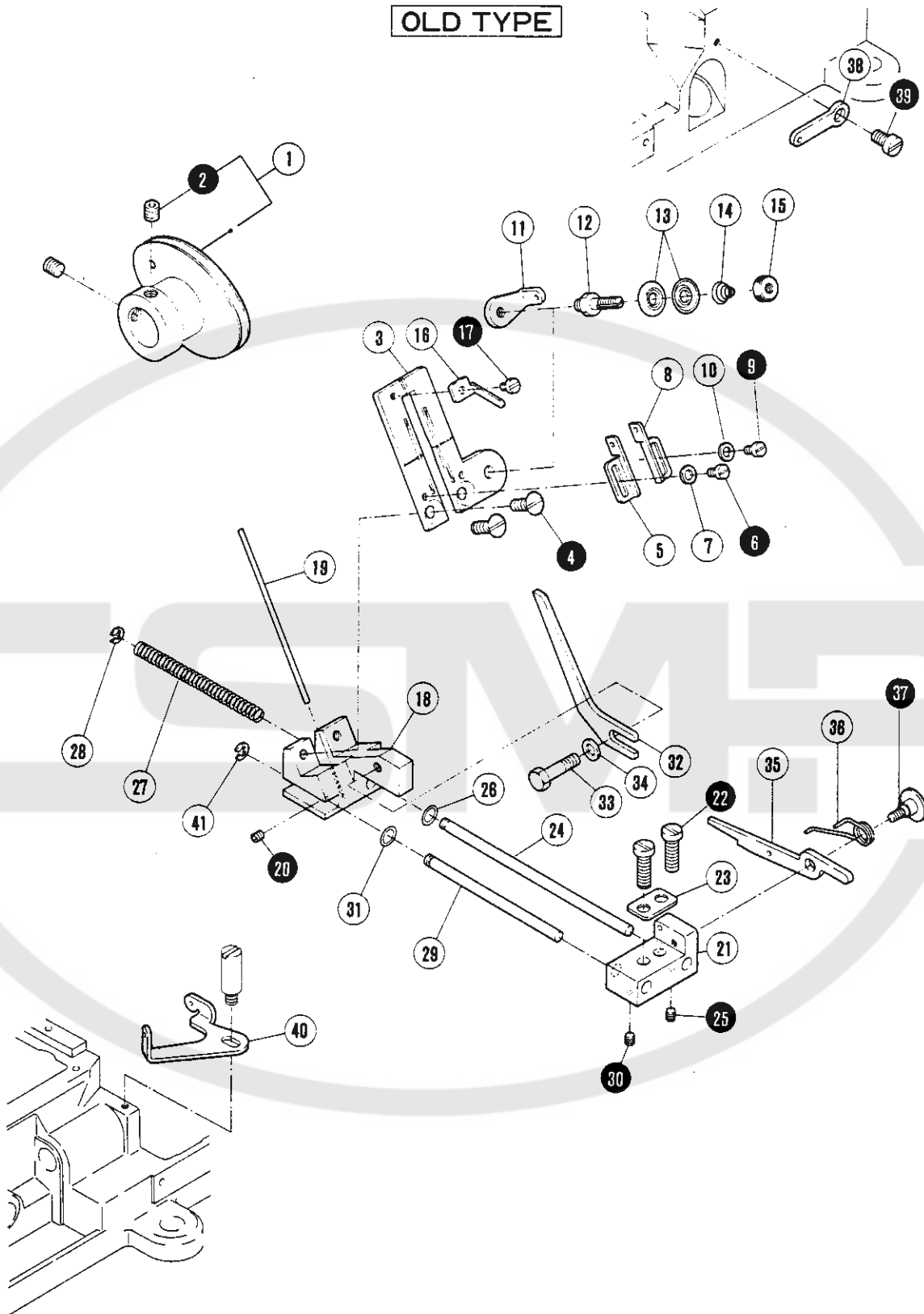

LOOPER THREAD HANDLING (OLD TYPE)

REF. NO.	PART NO.	PFAFF-NO.	NAME	QT.
1	253518A91	09-009817-37	THREAD TAKEUP	1
2	4514	11-330280-15	SCREW	2
3	253522A	09-009817-38	BRACKET	1
4	7043	11-210168-15	SCREW	2
* 5	253534	09-400313-00	THREAD GUIDE (LEFT)	1
6	7031	11-108849-15	SCREW	1
7	210585	09-009617-43	WASHER	1
8	253533	09-400312-00	THREAD GUIDE (RIGHT)	1
9	7031	11-108849-15	SCREW	1
10	210585	09-009617-43	WASHER	1
11	253535	09-400314-00	THREAD GUIDE	1
12	211387	09-009733-00	TENSION POST	1
13	137108	09-400096-00	TENSION DISC	2
14	211388	91-179419-05	SPRING	1
15	5526	09-400072-00	NUT	1
16	253542	09-009817-40	THREAD SUPPORT	1
17	7031	11-108849-15	SCREW	1
18	253523	09-400303-00	BRACKET	1
19	253532	09-400311-00	THREAD SUPPORT	1
20	4554	11-330082-15	SCREW	1
*21	253524A	09-400304-00	BRACKET	1
22	7023	11-108186-15	SCREW	2
23	210955A	09-009817-41	WASHER	1
24	253525	09-400305-00	SHAFT	1
25	4554	11-330082-15	SCREW	1
26	303865	09-009820-38	O RING	1
27	240115	09-400175-00	SPRING	1
28	200555	09-009071-03	RING	1
29	253526	09-400306-00	SHAFT	1
30	4554	11-330082-15	SCREW	1
31	303865	09-009820-38	O RING	1
32	253530	09-400309-00	THREAD GUIDE	1
33	4325	11-039171-15	SCREW	1
34	303448	12-305114-15	WASHER	1
35	253527	09-400307-00	STOPPER	1
36	253528	09-400308-00	SPRING	1
37	7087	09-400093-00	SCREW	1
38	253536	09-400315-00	THREAD GUIDE	1
39	7018	11-108171-15	SCREW	1
40	253543	09-009817-42	THREAD GUIDE	1
41	200555	09-009071-03	RING	1

Notice) Parts with mark * are not for sale.

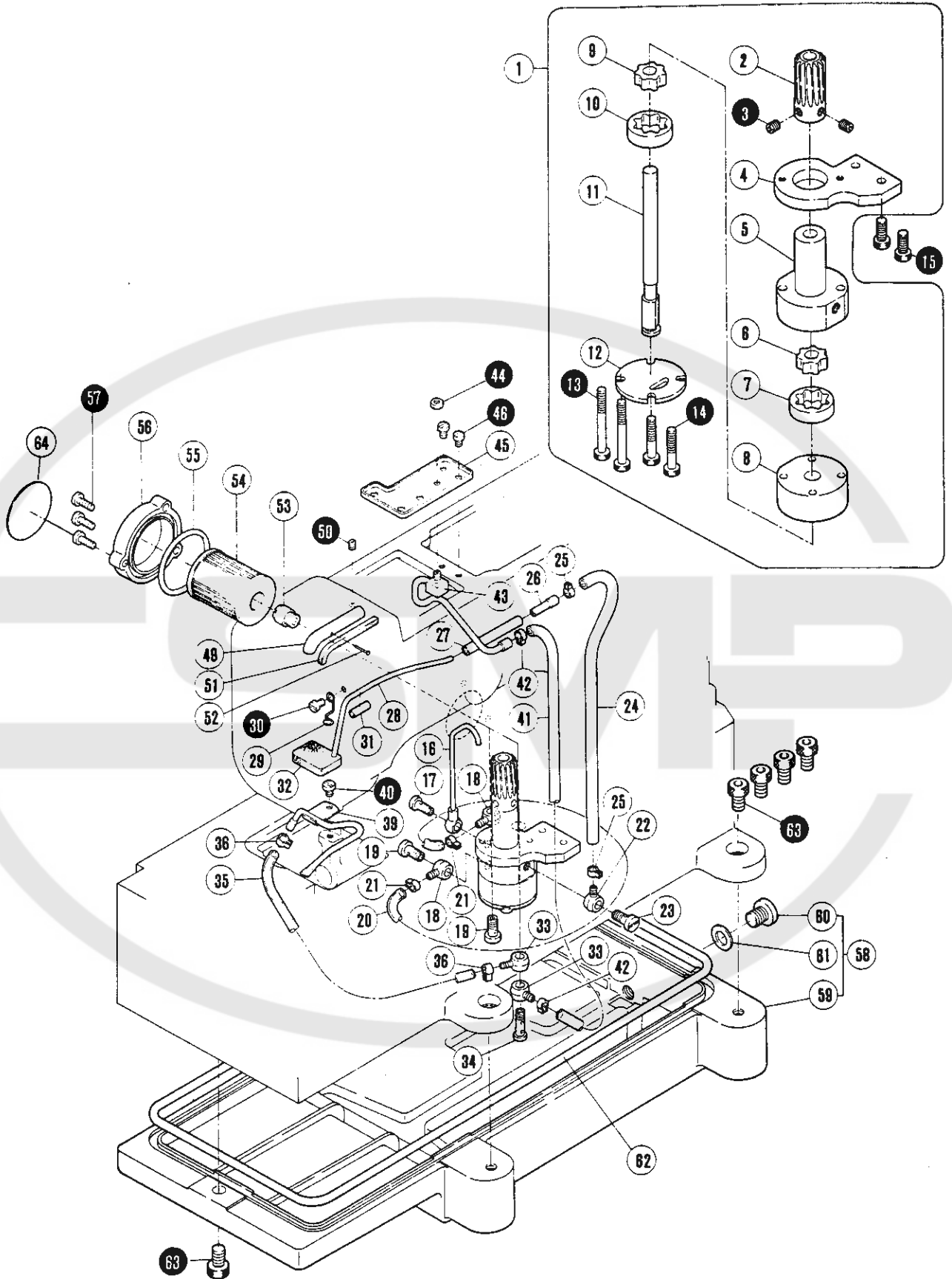

LUBRICATION MECHANISM

REF. NO.	PART NO.	PPAFF-NO.	NAME	QT.
1	255040-91	09-009817-43	PUMP ASSEMBLY	1
2	255019	09-400343-00	WORM WHEEL	1
3	4514	11-330280-15	SCREW	2
* 4	255033	09-400357-00	BRACKET	1
* 5	255022	09-400346-00	PUMP BODY	1
6	255025	09-400349-00	ROTOR	1
7	255027	09-400351-00	ROTOR	1
* 8	255023	09-400347-00	PUMP BODY	1
9	255026	09-400350-00	ROTOR	1
10	255027	09-400351-00	ROTOR	1
11	255024	09-400348-00	SHAFT	1
12	255028	09-400352-00	COVER	1
13	7105	09-009820-15	SCREW	2
14	7026	11-108198-15	SCREW	2
15	4531	11-130227-15	SCREW	2
16	255035-91	09-009817-47	PIPE	1
17	255037	09-009817-48	JOINT SCREW	1
18	200136	09-009054-86	JOINT	2
19	200152	09-009069-37	JOINT SCREW	2
20	205113A	09-009820-16	OIL TUBE	1
21	202199	09-009829-30	CLAMP	2
22	200136	09-009054-86	JOINT	1
23	200152	09-009069-37	JOINT SCREW	1
24	240135	09-400189-00	TUBE	1
25	202199	09-009829-30	CLAMP	2
26	255038	09-009817-50	JOINT	1
27	240144	09-009817-51	TUBE	1
28	255039	09-009817-52	PIPE	1
29	255005	09-400336-00	LATCH	1
30	7018	11-108171-15	SCREW	1
31	240143	09-400191-00	TUBE	1
32	255021	09-400345-00	FELT	1
33	200136	09-009054-86	JOINT	2
34	205111	09-400105-00	JOINT SCREW	1
35	240270	09-009827-47	TUBE	1
	240135	09-400189-00	TUBE	09 1 071088
36	202199	09-009829-30	CLAMP	2
37				
* 38	255034	09-400358-00	SPRING	09 1 071088
	7017	11-108168-15	SCREW	09 1 071088
39	255010-91	09-400509-00	OIL DISTRIBUTOR	1
40	7018	11-108171-15	SCREW	1
41	240134	09-400188-00	TUBE	1
42	202199	09-009829-30	CLAMP	2
43	255007-91	09-400508-00	OIL DISTRIBUTOR	1
44	4821	12-024151-15	NUT	1
45	255006	09-400337-00	OIL GUARD	1
46	7018	11-108171-15	SCREW	2
47				
	255017	09-400342-00	WORM	10 1 100789
48	4547	11-341901-15	SCREW	10 2 100789
49	255003	09-400335-00	PIPE	1
50	4543	11-330955-15	SCREW	1
51	240136	09-400190-00	FELT	1
52				
	210766	09-009618-38	PIN	1 ??????
53	210200	09-009614-64	BRACKET/OIL FILTER	1
54	206233	09-009070-13	OIL FILTER	1
55	206431	09-009070-62	O RING	1
56	210201-SD	09-009831-65	OIL FILTER CAP	1
	210201-CD	09-009814-80	OIL FILTER CAP	09 1 050790
	210201-JD	09-009614-65	OIL FILTER CAP	09 1 100789
57	7021	11-108180-15	SCREW	3
58	255000-92	09-400507-00	OIL RESERVOIR	1
*59	255000	09-400332-00	OIL RESERVOIR	1
60	5138B	09-009067-17	SCREW	1
61	202287A	09-009051-76	WASHER	1
62	255001	09-400333-00	O RING	1
63	4504	09-400040-00	SCREW	5
64	9A3002	09-009814-81	FILTER SEAL	1

Notice) Parts with mark * are not for sale.

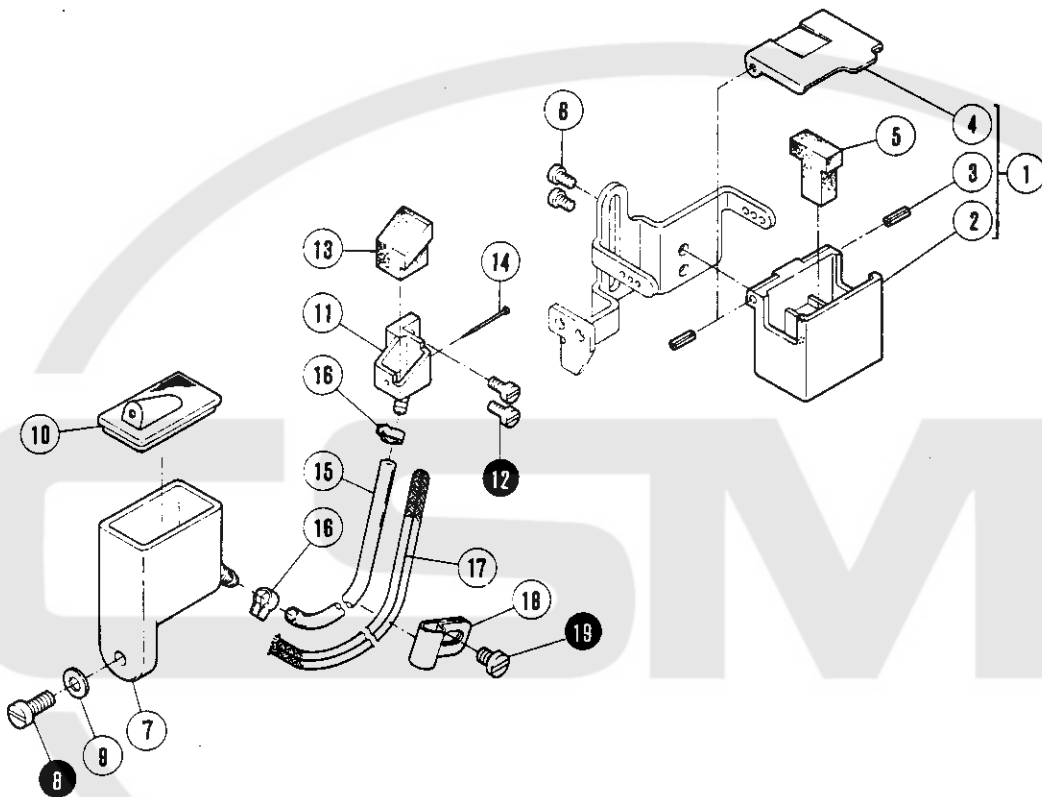

HR DEVICE

REF. NO.	PART NO.	PFAFF-NO.	NAME	QT.
1	207065-9U	09-009831-37	SILI. OIL RESERVOIR UPPER ASS.	1
	207065-9C	09-009827-42	SILICONE OIL RESERVOIR (UPPER)	09 1 050790
	207065-RA	09-400443-00	SILICONE OIL RESERVOIR (UPPER)	09 1 100789
* 2	207066-UD	09-009831-38	SILICONE OIL RESERVOIR (UPPER)	1
	207066-CD	09-009827-43	SILICONE OIL RESERVOIR (UPPER)	09 1 050790
	207066-RA	09-009817-53	SILICONE OIL RESERVOIR (UPPER)	09 1 100789
3	206781	09-009820-18	PIN	2
4	207067-UD	09-009831-39	CAP	1
	207067-CD	09-009827-44	CAP	09 1 050790
	207067-RA	09-400445-00	CAP	09 1 100789
5	207068	09-400143-00	FELT	1
6	5053	09-009053-62	SCREW	2
7	255015	09-400340-00	SILICONE OIL RESERVOIR (LOWER)	1
8	7020	11-108177-15	SCREW	1
9	303448	12-305114-15	WASHER	1
10	255016	09-400341-00	CAP	1
11	255013	09-400338-00	NEEDLE COOLER (LOWER)	1
12	7010	11-108093-15	SCREW	2
13	255014	09-400339-00	FELT	1
*14	210766	09-009618-38	PIN	1
15	240117	09-400177-00	TUBE	1
16	200155	09-009065-56	TUBE CLAMP	1
*17	202175	09-009601-64	OIL WICK	1
18	206115	09-009612-89	HOLDER	1
19	7017	11-108168-15	SCREW	1

Notice) Parts with mark * are not for sale.

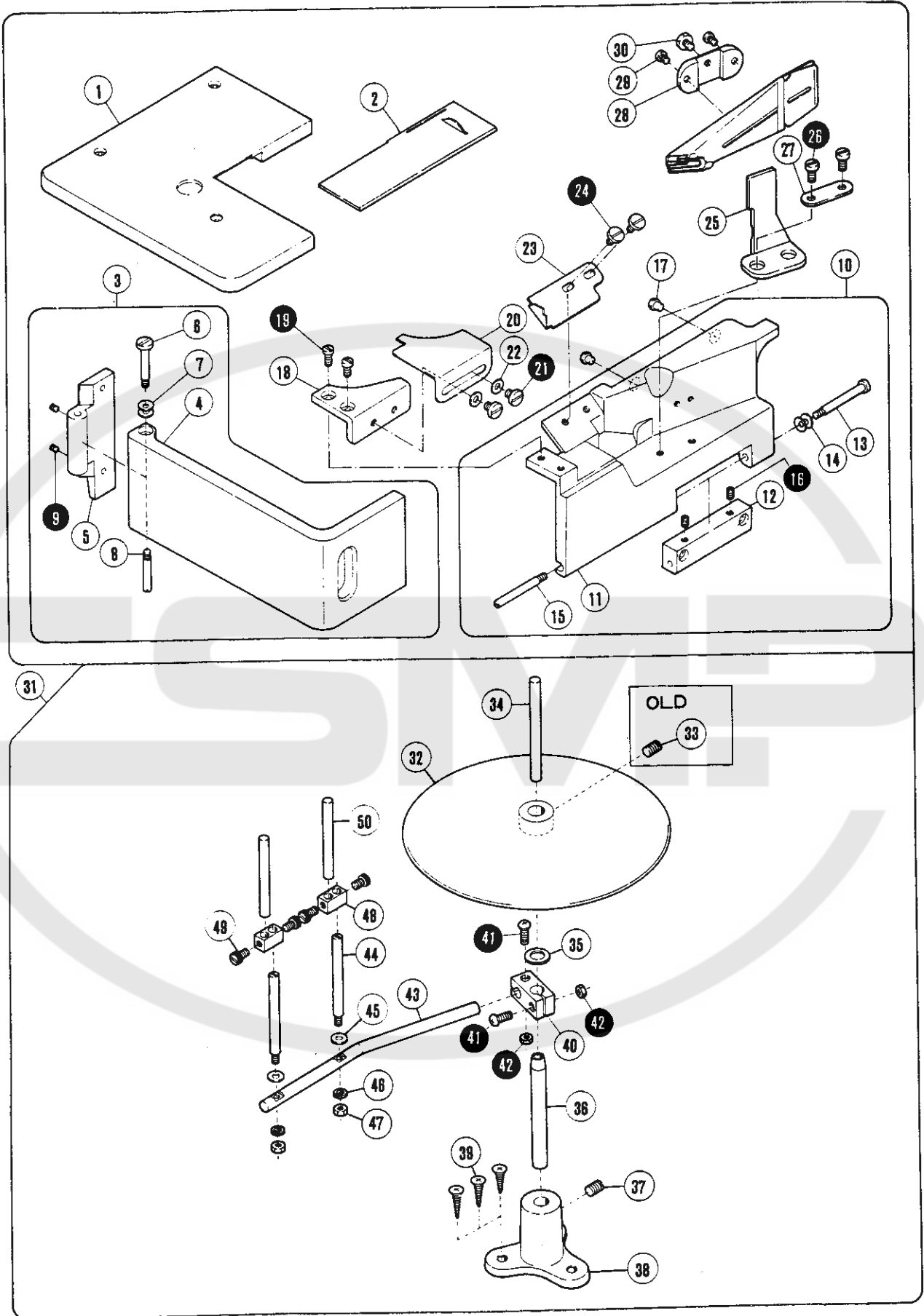

SPECIFIC PARTS

REF. NO.	PART NO.	PFAFF-NO.	NAME	QT.
1	250052BSD	09-009840-40	BED COVER (LEFT)	1
	250052BCD	09-009820-30	BED COVER (LEFT)	09 1 050790
2	250008	09-400196-00	COVER	1
3	250039-SD	09-009840-38	SIDE COVER COMPLETE	1
	250039-CD	09-009820-28	SIDE COVER COMPLETE	09 1 050790
* 4	250035	09-400212-00	SIDE COVER	1
* 5	250036	09-400213-00	HINGE	1
6	250037	09-400214-00	SCREW	1
7	201191	09-009050-43	SPRING	2
8	250038	09-400215-00	SCREW	1
9	4535	11-330085-15	SCREW	2
10	250033-SD	09-009840-36	FRONT COVER ASSEMBLY	1
	250033-CD	09-400456-00	FRONT COVER ASSEMBLY	09 1 050790
*11	250015	09-400202-00	FRONT COVER	1
*12	250012	09-400199-00	HINGE	1
13	250013	09-400200-00	SCREW	1
14	201191	09-009050-43	SPRING	2
15	250014	09-400201-00	SCREW	1
16	4539	11-330217-15	SCREW	2
17	210025	09-009613-16	CUSHION	2
18	250050-SD	09-009840-39	FRONT COVER (SMALL)	1
	250050-CD	09-400461-00	FRONT COVER (SMALL)	09 1 050790
19	7027	11-108222-15	SCREW	2
20	206439	09-400126-00	AUXILIARY PLATE/FRONT COVER	1
21	7079	09-400085-00	SCREW	2
22	204585	09-009602-15	WASHER	2
23	206601A	09-009827-41	FABRIC GUARD	1
	206601	09-400138-00	FABRIC GUARD	01 1 100388
24	7079	09-400085-00	SCREW	2
25	201914	09-400102-00	BRACKET/TAPE BINDER	1
26	7028	11-108225-15	SCREW	2
27	206460	09-400127-00	WASHER	1
28	201913	09-400101-00	CLAMP PLATE	1
29	5113	09-009054-70	SCREW	2
30	5540	09-400073-00	SCREW	1
31	257A9C	09-400400-00	TAPE GUIDE ASSEMBLY	1
* 32	257A91	09-400400-00	TAPE GUIDE ASSEMBLY	09 1 100789
33	247-CA	09-400192-00	TAPE BASE	1
	1457	09-009048-64	SCREW	10 1
34	253	09-400013-00	PIN	1
35	270	09-400016-00	WASHER	1
36	250	09-400011-00	TAPE DISC POST	1
37	1448	09-009054-64	SCREW	1
38	251-CA	09-009820-13	BRACKET	1
39	4913	09-009618-05	SCREW	3
40	256-CA	09-009820-14	HOLDER	1
41	4012	09-009612-25	SCREW	2
42	4803	09-009612-30	NUT	2
43	255	09-400015-00	BAR	1
44	252	09-400012-00	SCREW	2
45	204585	09-009602-15	WASHER	2
46	303067	12-501170-45	SPRING WASHER	2
47	226	09-009619-15	NUT	2
48	254	09-400014-00	HOLDER	2
49	5161	09-400068-00	SCREW	4
50	253	09-400013-00	PIN	2

Notice) Parts with mark * are not for sale.

4562-05-07
4542

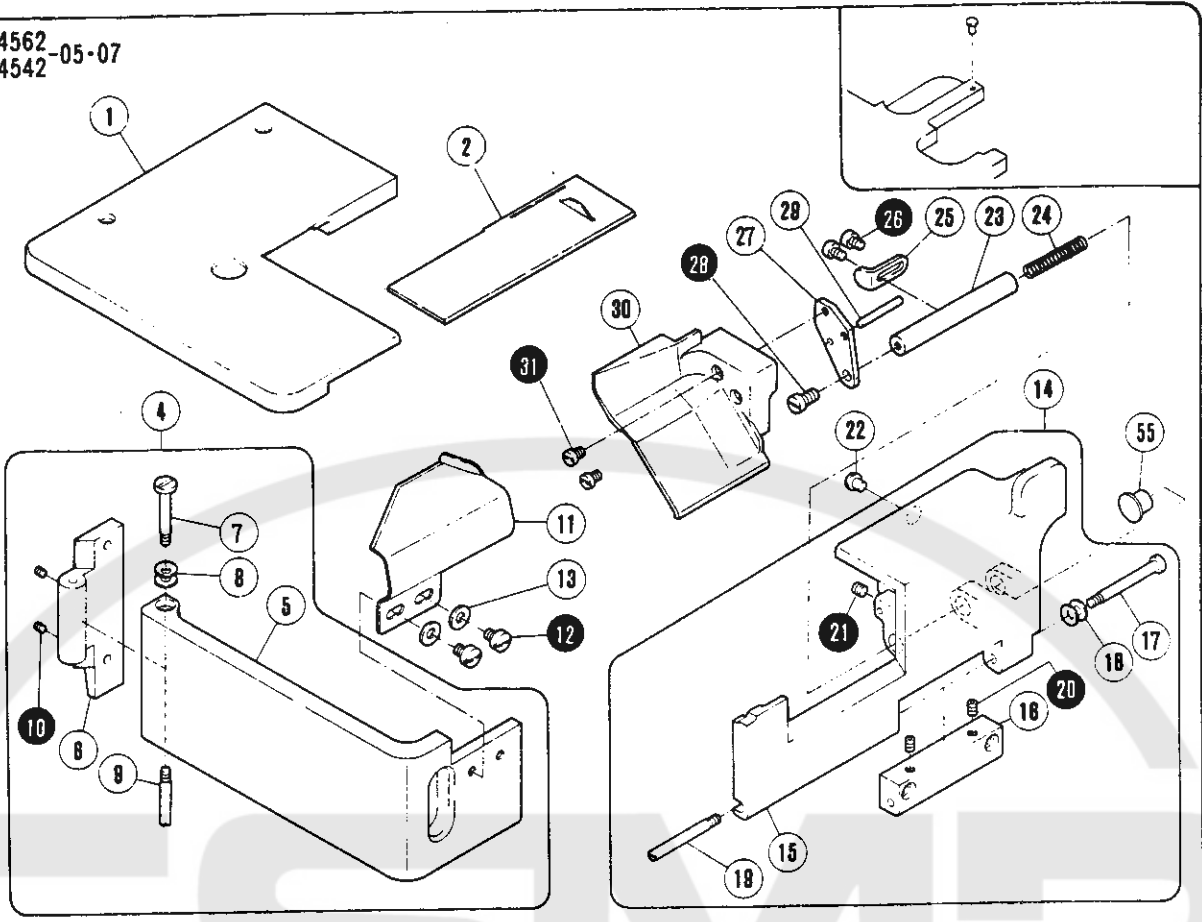

4562-06
4542

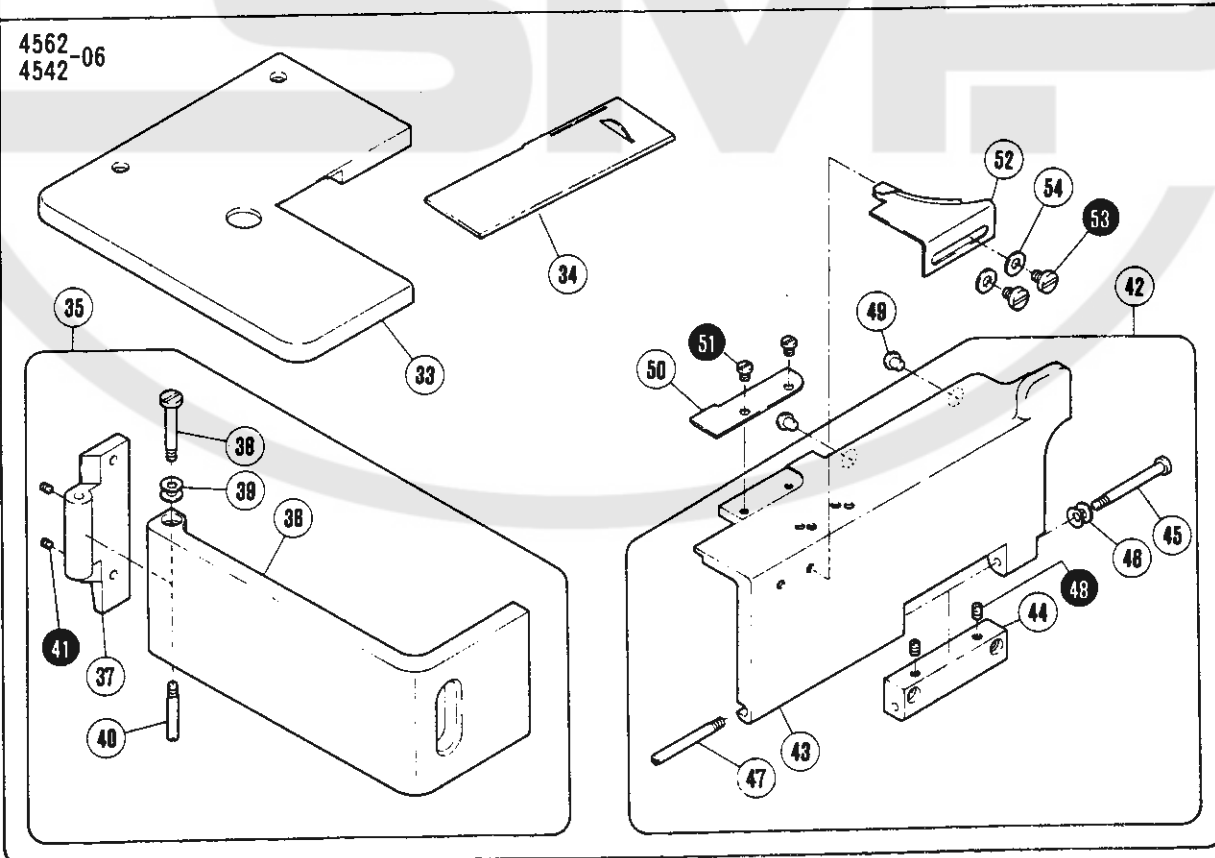

SPECIFIC PARTS

REF. NO.	PART NO.	PFAFF-NO.	NAME	QT.
1	250052CSD	09-009840-41	BED COVER (LEFT)	1
	250052CCD	09-400463-00	BED COVER (LEFT)	09 1 050790
2	250071-91	09-009816-80	SLIDE PLATE	1
	250030	09-400210-00	COVER	15 1 100789
3				
	250031	09-400211-00	COVER (SMALL)	1
4	250039ASD	09-009834-00	SIDE COVER COMPLETE	1
	250039ACD	09-009820-29	SIDE COVER COMPLETE	09 1 050790
* 5	250035A	09-400441-00	SIDE COVER	1
* 6	250036	09-400213-00	HINGE	1
7	250037	09-400214-00	SCREW	1
8	201191	09-009050-43	SPRING	2
9	250038	09-400215-00	SCREW	1
10	4535	11-330085-15	SCREW	2
11	255517	09-400372-00	FABRIC GUIDE	1
12	7079	09-400085-00	SCREW	2
13	204585	09-009602-15	WASHER	2
14	250034-SD	09-009840-37	FRONT COVER ASSEMBLY	1
	250034-CD	09-009820-27	FRONT COVER ASSEMBLY	09 1 050790
* 15	250024	09-009206-00	FRONT COVER	1
* 16	250012	09-400199-00	HINGE	1
17	250013	09-400200-00	SCREW	1
18	201191	09-009050-43	SPRING	2
19	250014	09-400201-00	SCREW	1
20	4539	11-330217-15	SCREW	2
21	4514	11-330280-15	SCREW	1
22	210025	09-009613-16	CUSHION	1
23	250027	09-400208-00	SHAFT	1
24	202340	09-009612-73	SPRING	1
25	250028	09-400209-00	STOPPER	1
26	7018	11-108171-15	SCREW	2
27	250026	09-400207-00	BRACKET	1
28	7028	11-108225-15	SCREW	1
29	306920	09-400437-00	PIN	1
30	250025-ME	09-400453-00	FRONT COVER (SMALL)	1
31	7018	11-108171-15	SCREW	2
32	202588	09-009052-70	WASHER	1
33	250052BSD	09-009840-40	BED COVER (LEFT)	1
	250052BCD	09-009820-30	BED COVER (LEFT)	09 1 050790
34	250008	09-400196-00	COVER	1
35	250039-SD	09-009840-38	SIDE COVER COMPLETE	1
	250039-CD	09-009820-28	SIDE COVER COMPLETE	09 1 050790
* 36	250035	09-400212-00	SIDE COVER	1
* 37	250036	09-400213-00	HINGE	1
38	250037	09-400214-00	SCREW	1
39	201191	09-009050-43	SPRING	2
40	250038	09-400215-00	SCREW	1
41	4535	11-330085-15	SCREW	2
42	250032BSD	09-009836-46	FRONT COVER ASSEMBLY	1
	250032BCD	09-009827-54	FRONT COVER ASSEMBLY	09 1 050790
	250032ACD	09-009820-25	FRONT COVER ASSEMBLY	09 1 100789
* 43	250011A	09-400440-00	FRONT COVER	1
* 44	250012	09-400199-00	HINGE	1
45	250013	09-400200-00	SCREW	1
46	201191	09-009050-43	SPRING	2
47	250014	09-400201-00	SCREW	1
48	4539	11-330217-15	SCREW	2
49	210025	09-009613-16	CUSHION	2
50	306728	09-400436-00	COVER	1
51	7069	91-700335-15	SCREW	2
52	306157	09-400415-00	CLOTH GUIDE	1
53	7079	09-400085-00	SCREW	2
54	204585	09-009602-15	WASHER	2
55	250066	09-009827-55	PLUG	1

Notice) Parts with mark * are not for sale.

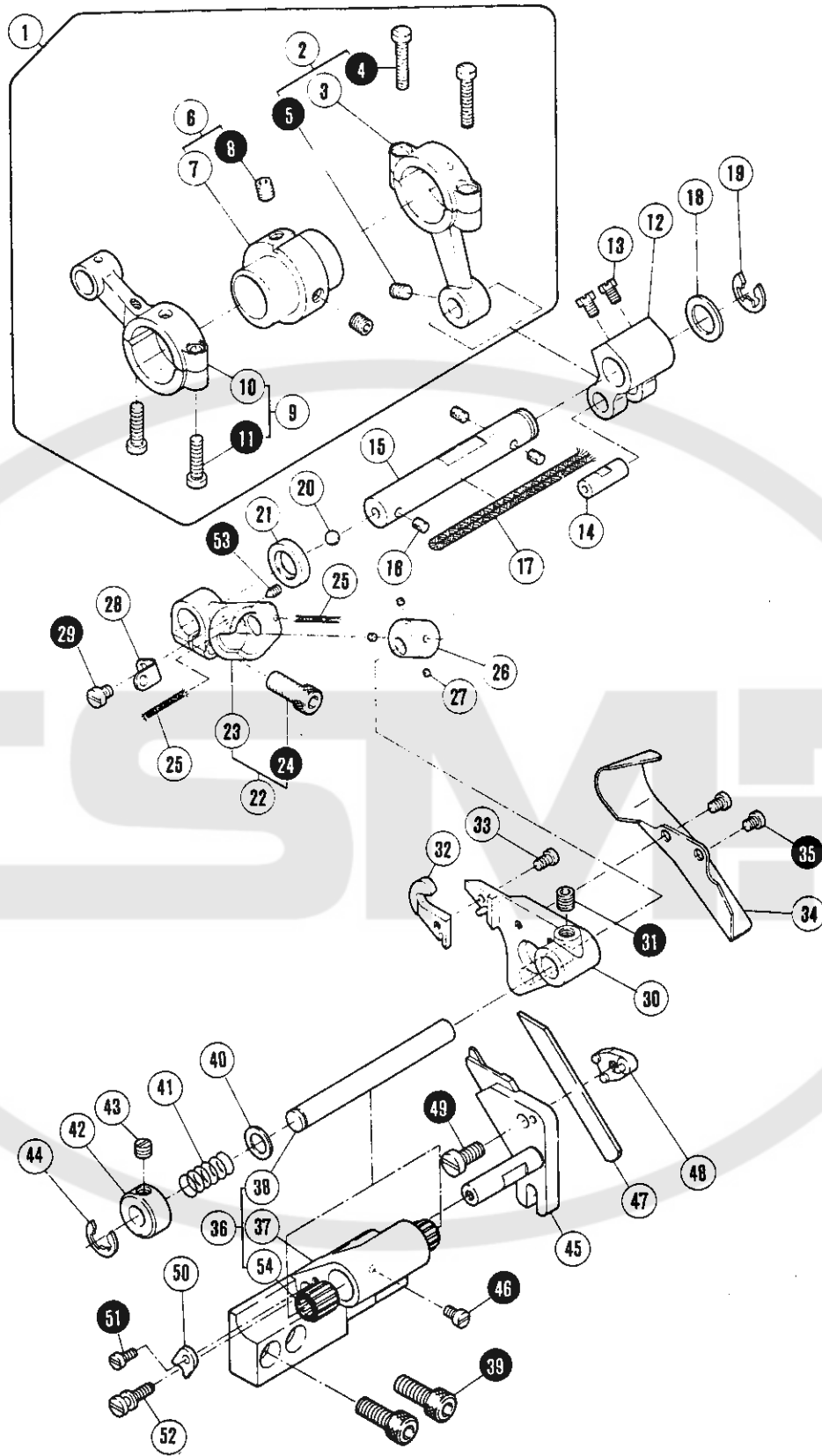

FT DEVICE

REF. NO.	PART NO.	PFAFF-NO.	NAME	QT.
1	255516-91	09-400516-00	ECCENTRIC-CONNECTION ASSEMBLY	1
2	255501-92	09-400512-00	CONNECTION ASSEMBLY	1
* 3	255501	09-400360-00	CONNECTION	1
4	7015	11-108144-15	SCREW	2
5	4543	11-330955-15	SCREW	1
6	255500-92	09-400511-00	ECCENTRIC ASSEMBLY	1
* 7	255500	09-400359-00	ECCENTRIC	1
8	4539	11-330217-15	SCREW	2
9	252001-92	09-400479-00	CONNECTION ASSEMBLY	1
*10	252001	09-400241-00	CONNECTION	1
11	7015	11-108144-15	SCREW	2
12	306093	09-400413-00	CRANK	1
13	5084	09-009053-76	SCREW	2
14	205495-2	09-009603-81	PIN	1
15	255502	09-400361-00	SHAFT	1
16	206748	09-400139-00	FELT	3
*17	202176	26-536302-09	OIL WICK	1
18	240102	09-400167-00	WASHER	1
19	205061	12-640200-55	RING	1
20	240097	09-400164-00	PLUG	1
21	204052A	09-009064-62	OIL SEAL	1
22	255503-92	09-400513-00	LEVER ASSEMBLY	1
*23	255503	09-400362-00	LEVER	1
24	4501	09-400039-00	SCREW	1
*25	202174	09-009612-11	OIL WICK	2
26	255505	09-400364-00	BLOCK	1
27	207925	09-400146-00	FELT	3
28	255504	09-400363-00	LATCH	1
29	7009	11-108090-15	SCREW	1
30	255507-91	09-400514-00	UPPER KNIFE LEVER ASSEMBLY	1
31	4547	11-341901-15	SCREW	1
32	306394	09-400427-00	UPPER KNIFE	1
33	5109	09-009053-87	SCREW	1
34	255515	09-400371-00	CHIP GUARD	1
35	7008	11-108087-15	SCREW	2
*36	255514-91	09-400515-00	BRACKET COMPLETE	1
37	255506	09-400365-00	BRACKET	1
38	255508-2	09-009817-55	SHAFT	1
39	4515	09-400044-00	SCREW	2
40	207045	09-400142-00	WASHER	1
41	306105	09-400414-00	SPRING	1
42	192024	09-400098-00	COLLAR	1
43	W00024-1	09-400000-00	SCREW	1
44	202522	09-009052-03	RING	1
45	255509	09-400367-00	LOWER KNIFE HOLDER	1
46	7036	11-174170-15	SCREW	1
47	204161	09-009053-33	LOWER KNIFE	1
48	255510	09-400368-00	LOWER KNIFE CLAMP	1
49	7028	11-108225-15	SCREW	1
50	255511	09-400369-00	GUIDE	1
51	7010	11-108093-15	SCREW	1
52	255513	09-400370-00	SCREW	1
53	4545	11-335085-15	SCREW	1
54	240099	09-009817-54	NEEDLE BEARING	2

Notice) Parts with mark * are not for sale.

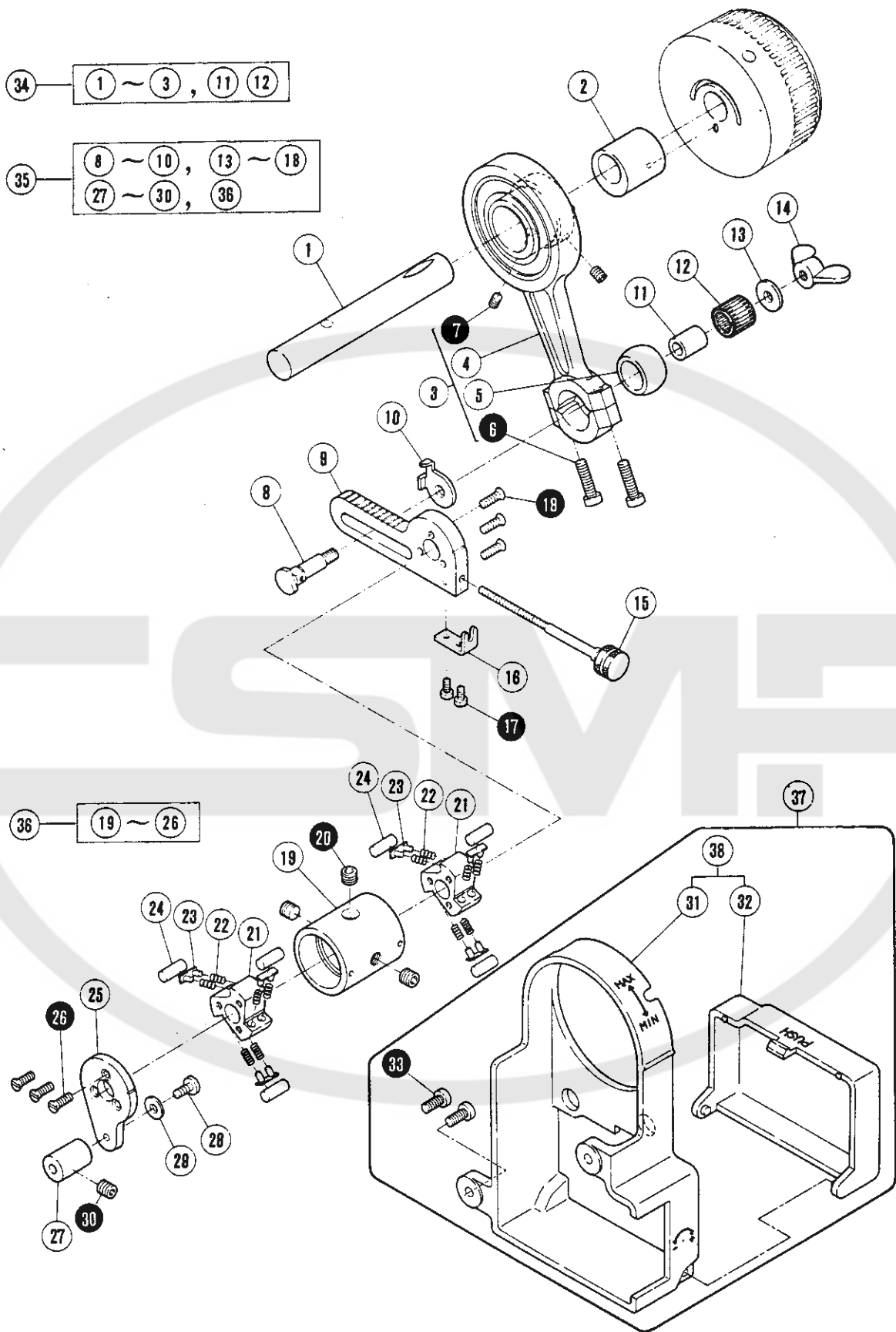

MD DEVICE (1)

REF. NO.	PART NO.	PFAFF-NO.	NAME	QT.
	256066C9U	09-009842-73	METERING DEVICE ASSEMBLY	1
1	256000	09-400374-00	SHAFT	1
2	256043-91	09-400524-00	ECCENTRIC ASSEMBLY	1
3	256005-91	09-400517-00	CONNECTION ASSEMBLY	1
4	256006-92	09-400518-00	CONNECTION ASSEMBLY	1
5	256007	09-400375-00	BALL STUD	1
6	7023	11-108186-15	SCREW	2
7	4514	11-330280-15	SCREW	2
8	256008	09-400376-00	PIN	1
9	256010	09-400378-00	CRANK	1
10	256009	09-400377-00	INDICATOR	1
11	306238	09-400416-00	BUSHING	1
12	306239	09-400417-00	NEEDLE BEARING	1
13	204023	09-009055-16	WASHER	1
14	256048	09-400399-00	NUT	1
15	256041	09-400394-00	SCREW	1
16	256042	09-400395-00	STOP PLATE	1
17	7010	11-108093-15	SCREW	2
18	7083	09-400089-00	SCREW	3
19	256046	09-400397-00	SLEEVE	1
20	4547	11-341901-15	SCREW	3
21	256012	09-400380-00	CLUTCH	2
22	240114A	09-009817-56	SPRING	12
23	306243	09-400418-00	GUIDE PLATE ASSEMBLY	6
24	306500	09-400434-00	PIN	6
25	256011	09-400379-00	STOP PLATE	1
26	7083	09-400089-00	SCREW	3
27	306568	09-400435-00	PIN	1
28	5117	09-009053-88	SCREW	1
29	201185	09-009050-38	WASHER	1
30	4514	11-330280-15	SCREW	1
31	250067-KB	09-009840-42	COVER	1
	250067-BB	09-009817-57	COVER	09 1 050790
32	250068-KB	09-009817-58	COVER	1
	250068-BB	09-009820-40	COVER	09 1 050790
33	7020	11-108177-15	SCREW	2
34	256061-91	09-009820-72	ECCENTRIC-CONNECTION ASSEMBLY	1
35	256062-91	09-009827-84	CRANK ASSEMBLY	1
36	256049-91Y	09-009827-83	CLUTCH ASSEMBLY	1
37	250214-9U	09-009840-44	COVER ASSEMBLY	1
	250214-9B	09-009820-74	COVER ASSEMBLY	09 1 050790
38	250070-91H	09-009820-32	COVER COMPLETE	1

49 — 5 ~ 22, 28 ~ 46

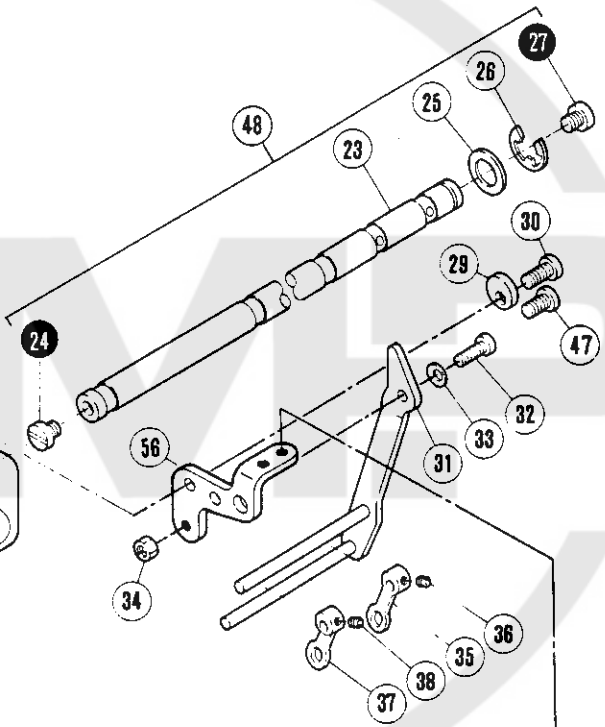
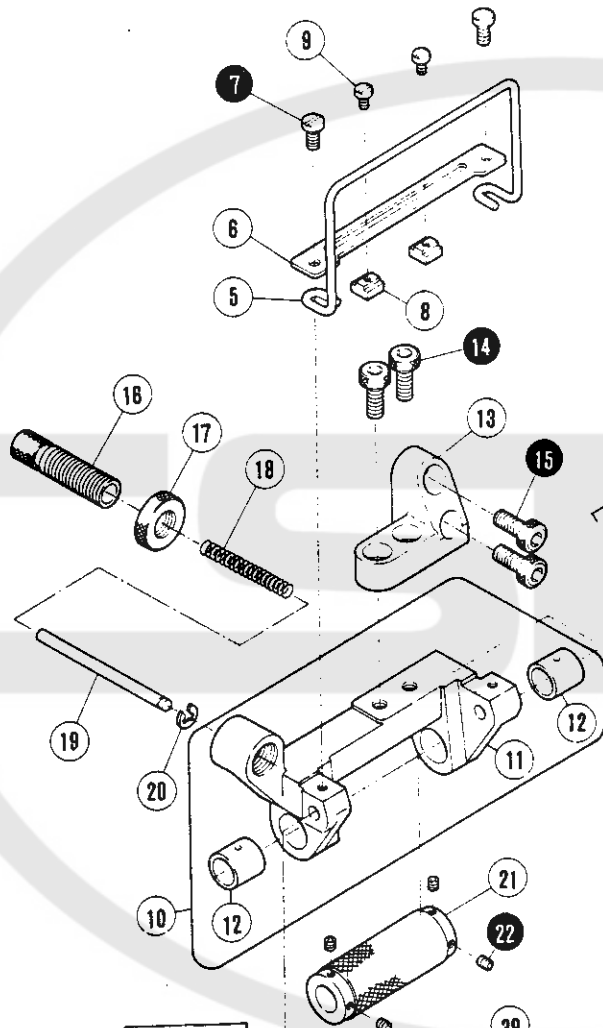
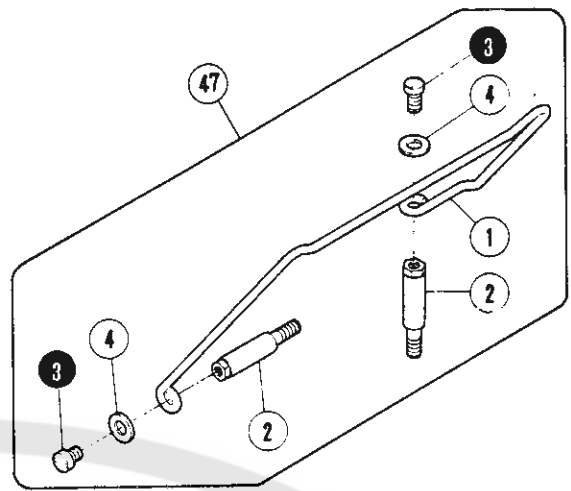

57 — 50 ~ 56

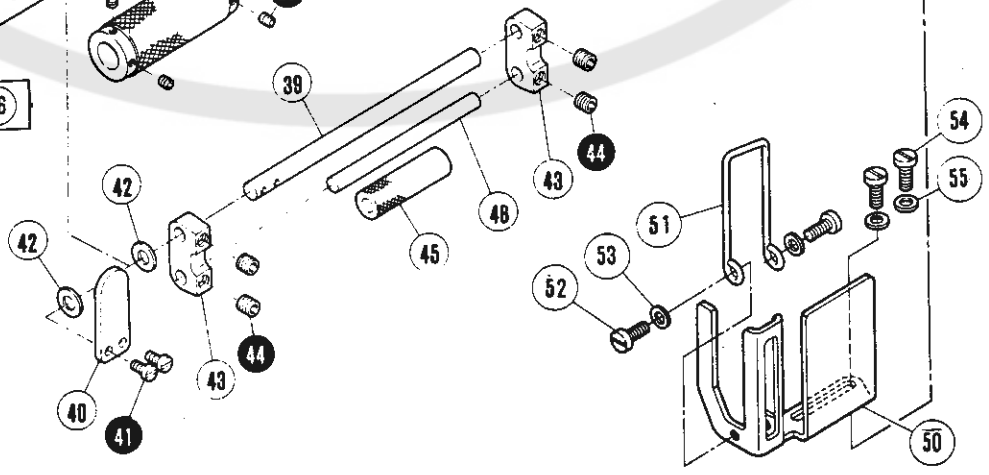

MD DEVICE (2)

REF. NO.	PART NO.	PFAFF-NO.	NAME	QT.
1	256030	09-400389-00	LACE GUIDE	1
2	256031	09-400390-00	SCREW	1
3	7019	11-108174-15	SCREW	2
4	204585	09-009602-15	WASHER	2
5	256027B	09-009827-82	LACE GUIDE	1
	256027	09-400388-00	LACE GUIDE	
6	256026	09-400387-00	GUIDE	1
7	7019	11-108174-15	SCREW	2
8	306057	09-400412-00	BLOCK	2
9	5141	09-009600-24	SCREW	2
10	256016-9S	09-009835-98	BRACKET COMPLETE	1
*	256016-CD	09-009828-00	BRACKET COMPLETE	09 1 050790
	256016ARA	09-009820-37	BRACKET COMPLETE	09 1 100789
11	256017-SD	09-009835-99	BRACKET	1
	256017-CD	09-009828-01	BRACKET	09 1 050790
	256017ARA	09-400520-00	BRACKET	09 1 100789
12	306364	09-400422-00	BUSHING	2
13	256018-SD	09-009836-00	BRACKET	1
	256018-CD	09-009828-01	BRACKET	09 1 050790
	256018-RA	09-400521-00	BRACKET	09 1 100789
14	4515	09-400044-00	SCREW	2
15	4515	09-400044-00	SCREW	2
16	306378	09-400425-00	SCREW	1
17	210328A	09-009829-18	ADJUSTING SCREW NUT	1
	306379	09-400426-00	NUT	1
18	306376	09-400423-00	SPRING	1
19	306377	09-400424-00	SHAFT	1
20	200555	09-009071-03	RING	1
21	256019-91	09-400522-00	ROLLER ASSEMBLY	1
22	4535	11-330085-15	SCREW	4
23	256014	09-400381-00	SHAFT	1
24	7074	09-400080-00	SCREW	1
25	240102	09-400167-00	WASHER	1
26	202577	09-009052-61	RING	1
27	7074	09-400080-00	SCREW	1
28				
	256037	09-400391-00	BRACKET	15 1
29	256038	09-400392-00	STOPPER	1
30	7020	11-108177-15	SCREW	1
31	256034-91	09-400523-00	BRACKET COMPLETE	1
32	4528	11-130179-15	SCREW	1
33	210930	09-009618-32	SPRING WASHER	2
34	4803	09-009612-30	NUT	1
35	256039A	09-400442-00	LACE GUIDE	1
36	4554	11-330082-15	SCREW	1
37	256039	09-400393-00	LACE GUIDE	1
38	4554	11-330082-15	SCREW	1
39	256023	09-400855-00	SHAFT	1
40	256024	09-400385-00	LEVER	1
41	7010	11-108093-15	SCREW	2
42	202433	09-009606-23	WASHER	2
43	256047	09-400398-00	BRACKET	2
44	4514	11-330280-15	SCREW	4
45	256022	09-400383-00	ROLLER	1
46	256025	09-400386-00	SHAFT	1
47	256065-91	09-009827-86	LACE GUIDE ASSEMBLY	1
48	256063-91	09-009820-75	SHAFT ASSEMBLY	1
49	256064B9S	09-009827-85	BASE/FEED ELASTIC	1
*	256064-9C	09-009827-85	BASE/FEED ELASTIC	09 1 050790
50	250225-SD	09-009832-97	THREAD TAKEUP GUARD	1
51	250226	09-009829-20	FINGER GUARD	1
52	7017	11-108168-15	SCREW	2
53	303448	12-305114-15	WASHER	2
54	7018	11-108171-15	SCREW	2
55	303448	12-305114-15	WASHER	2
56	250228-SD	09-009840-48	BRACKET	1
*57	250231B9C	09-009829-26	THREAD TAKEUP COVER	1

Notice) Parts with mark * are not for sale.

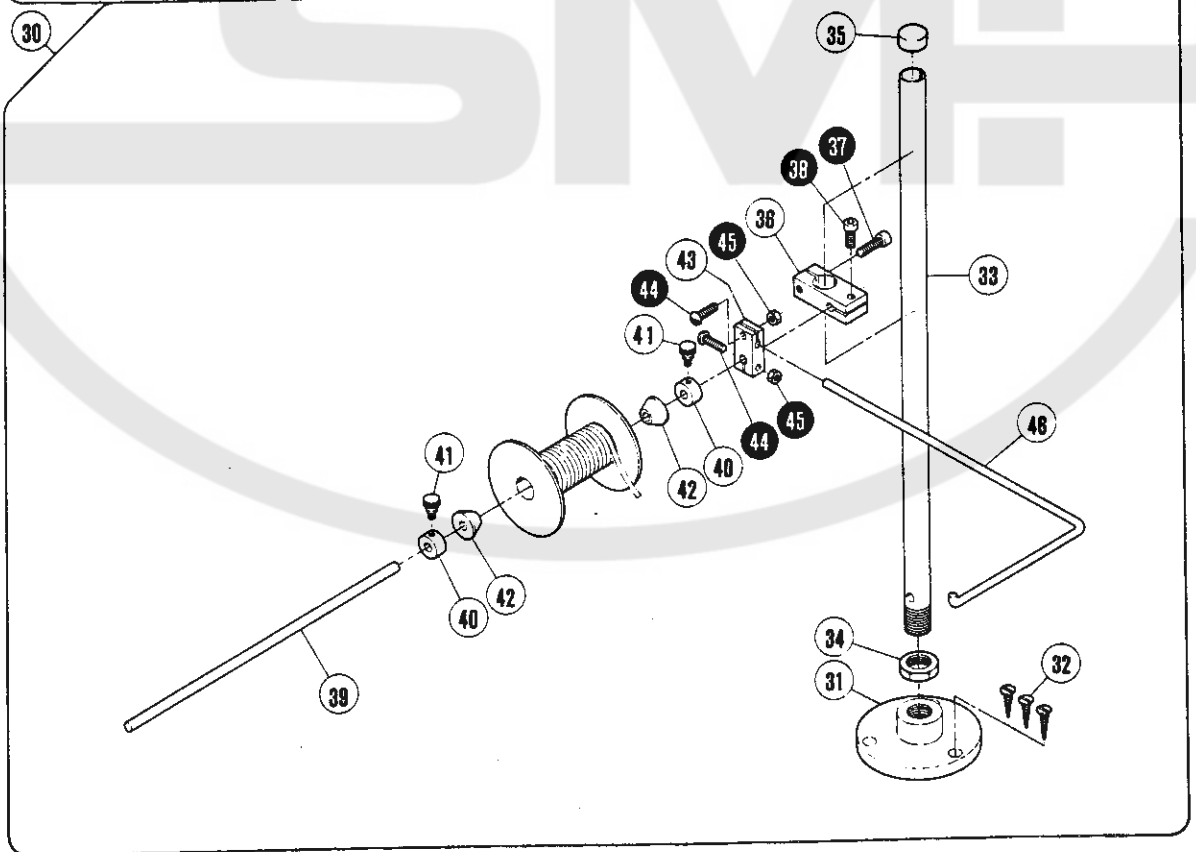
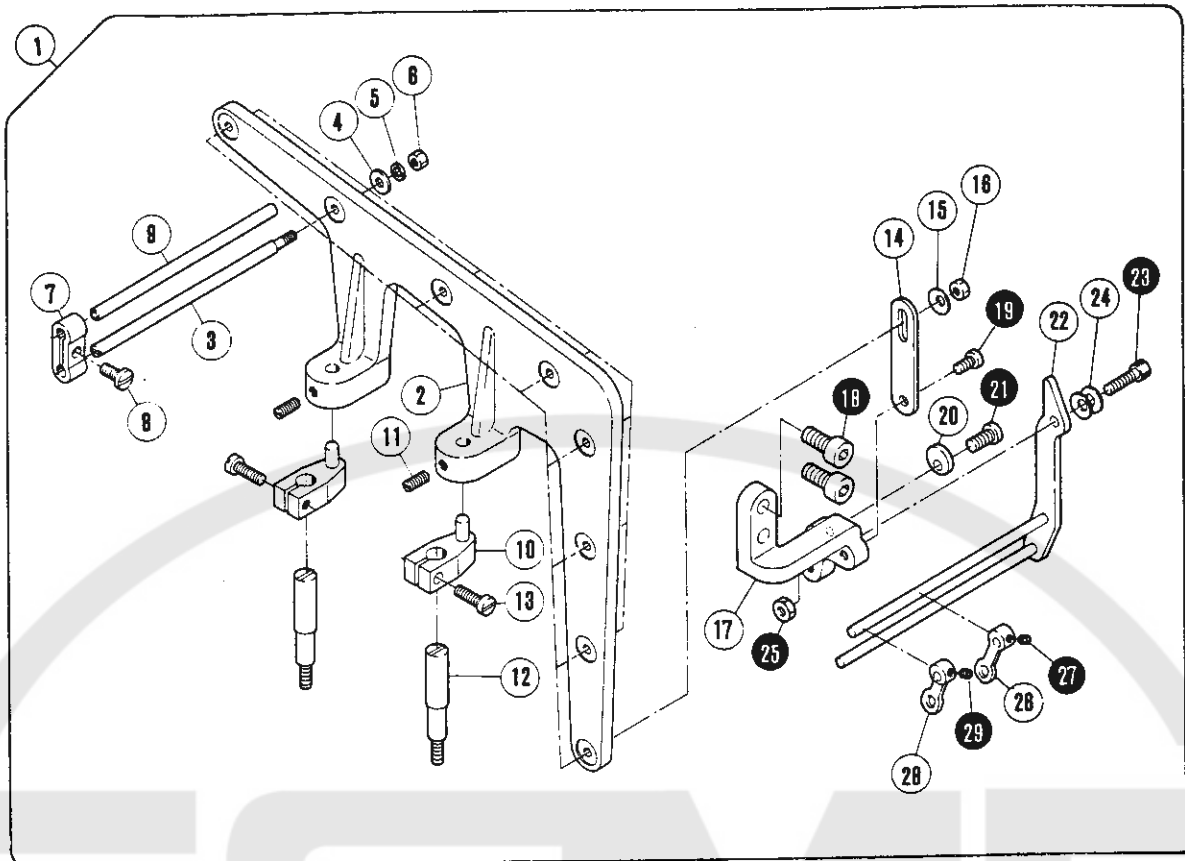

LACE GUIDE REEL STAND

REF. NO.	PART NO.	PFAFF-NO.	NAME	QT.
1	258000-91	09-400761-00	LACE GUIDE ASSEMBLY	1
2	306249-RA	09-009763-00	BRACKET	1
3	306250	09-400419-00	PIN	8
4	167066	09-009601-53	WASHER	7
5	201252	09-009050-73	SPRING WASHER	7
6	3091	09-009053-50	NUT	7
7	306252	09-400421-00	COLLAR	8
8	5116	09-400067-00	SCREW	8
9	306251	09-400420-00	PIN	8
10	206213	09-400124-00	BELL CRANK	2
11	5234	09-009065-83	SCREW	2
12	258001	09-400406-00	SCREW	2
13	5187	09-009601-05	SCREW	2
14	258003	09-400408-00	JOINT	1
15	210930	09-009618-32	SPRING WASHER	1
16	3091	09-009053-50	NUT	1
17	258002	09-400407-00	BRACKET	1
18	4515	09-400044-00	SCREW	2
19	7019	11-108174-15	SCREW	1
20	256038	09-400392-00	STOPPER	1
21	4527	11-130173-15	SCREW	1
22	258004-91	09-400762-00	BRACKET COMPLETE	1
23	4529	11-130185-15	SCREW	1
24	210930	09-009618-32	SPRING WASHER	2
25	4803	09-009612-30	NUT	1
26	256039A	09-400442-00	LACE GUIDE	1
27	4554	11-330082-15	SCREW	1
28	256039	09-400393-00	LACE GUIDE	1
29	4554	11-330082-15	SCREW	1
30	306469A9C	09-400433-00	REEL STAND ASSEMBLY	1
31	306468-CA	09-009820-49	THREAD BRACKET	1
32	4913	09-009618-05	SCREW	3
33	306466-CA	09-009820-48	ROD	1
34	5476	09-009612-45	NUT	1
35	386	09-009612-19	ROD CAP	1
36	383-CA	09-009815-16	BRACKET	1
37	4014	09-009612-27	SCREW	1
38	4803	09-009612-30	NUT	1
39	306464	09-400430-00	BAR	1
40	306463	09-400429-00	COLLAR	2
41	1285	09-400034-00	SCREW	2
42	306462	09-400428-00	REEL GUIDE	2
43	233-CA	09-009619-24	HOLDER	1
44	4012	09-009612-25	SCREW	2
45	4803	09-009612-30	NUT	2
46	306467	09-400432-00	ROD	1

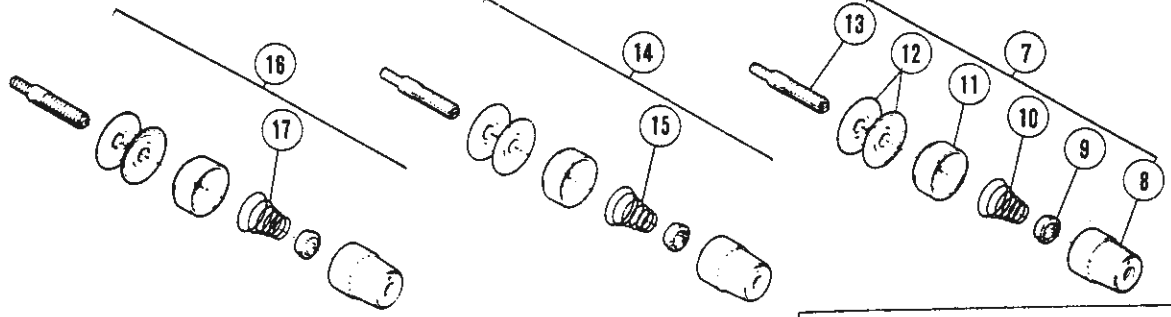
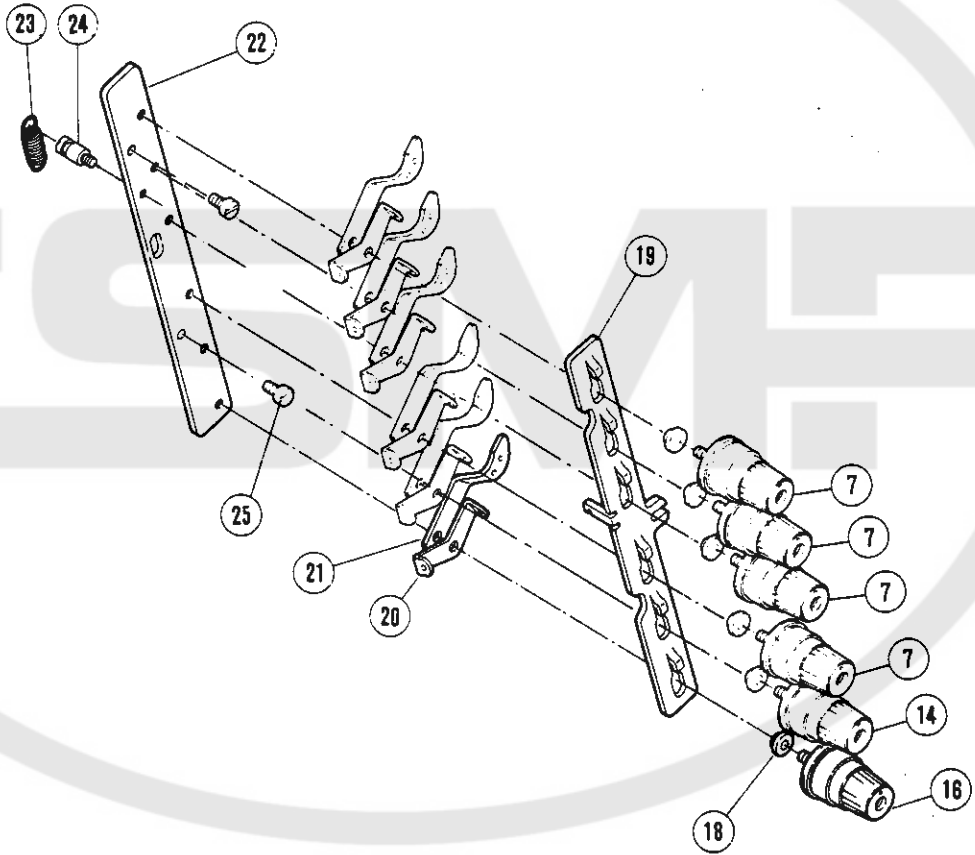
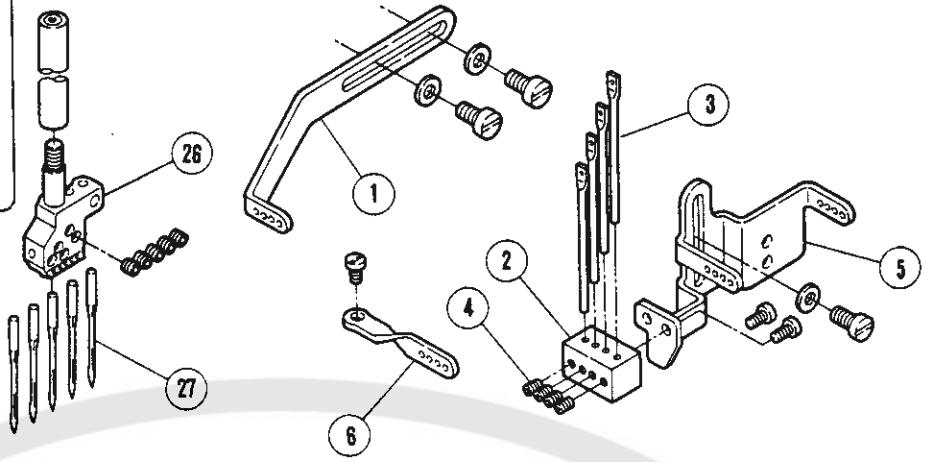
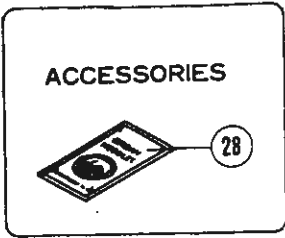

Refer to Page 6, 14, 20, 28, 30

4562-01DB
4561-01DB SPECIFIC PARTS

REF. NO.	PART NO.	PFAFF-NO.	NAME	QT.
1	253505B	09-400289-00	THREAD TAKEUP	1
2	253545A	09-009842-78	HOLDER	1
3	234521	09-009817-36	THREAD GUIDE	4
4	4535	11-330085-15	SCREW	4
5	253544A	09-009842-74	THREAD GUIDE	1
6	253507A	09-009842-75	THREAD GUIDE	1
7	254010A9U	09-009835-38	THREAD TENSION COMPLETE	4
8	208447-UA	09-009826-29	POST NUT	1
9	208448	09-009607-59	SPRING BUSHING	1
10	201037	09-009049-22	SPRING (HEAVY)	1
11	208450-UA	09-009831-64	CUP	1
12	210319	09-009615-68	TENSION DISC	2
13	1817-2A	09-400438-00	SCREW STUD	1
14	254010B9U	09-009835-39	THREAD TENSION COMPLETE	1
15	201086	09-009049-57	SPRING (MEDIUM)	1
16	254010C9U	09-009835-40	THREAD TENSION COMPLETE	1
17	201068	09-009049-44	SPRING (LIGHT)	1
18	206202	09-400122-00	TENSION POST COLLAR	6
19	254021A	09-009842-76	THREAD RELEASER	1
20	254020	09-009827-97	THREAD GUIDE	6
21	206203	09-400123-00	THREAD GUIDE	6
22	254019A	09-009842-77	BRACKET	1
23	306301	09-009826-60	SPRING	1
24	5447	09-009826-61	SCREW	1
25	7019	11-108174-15	SCREW	2
26	XXXXXX		NEEDLE HOLDER	1
* 27	SMX1014B		NEEDLE	5
* 28	681B		NEEDLE	1

Notice) Parts with mark * are not for sale.

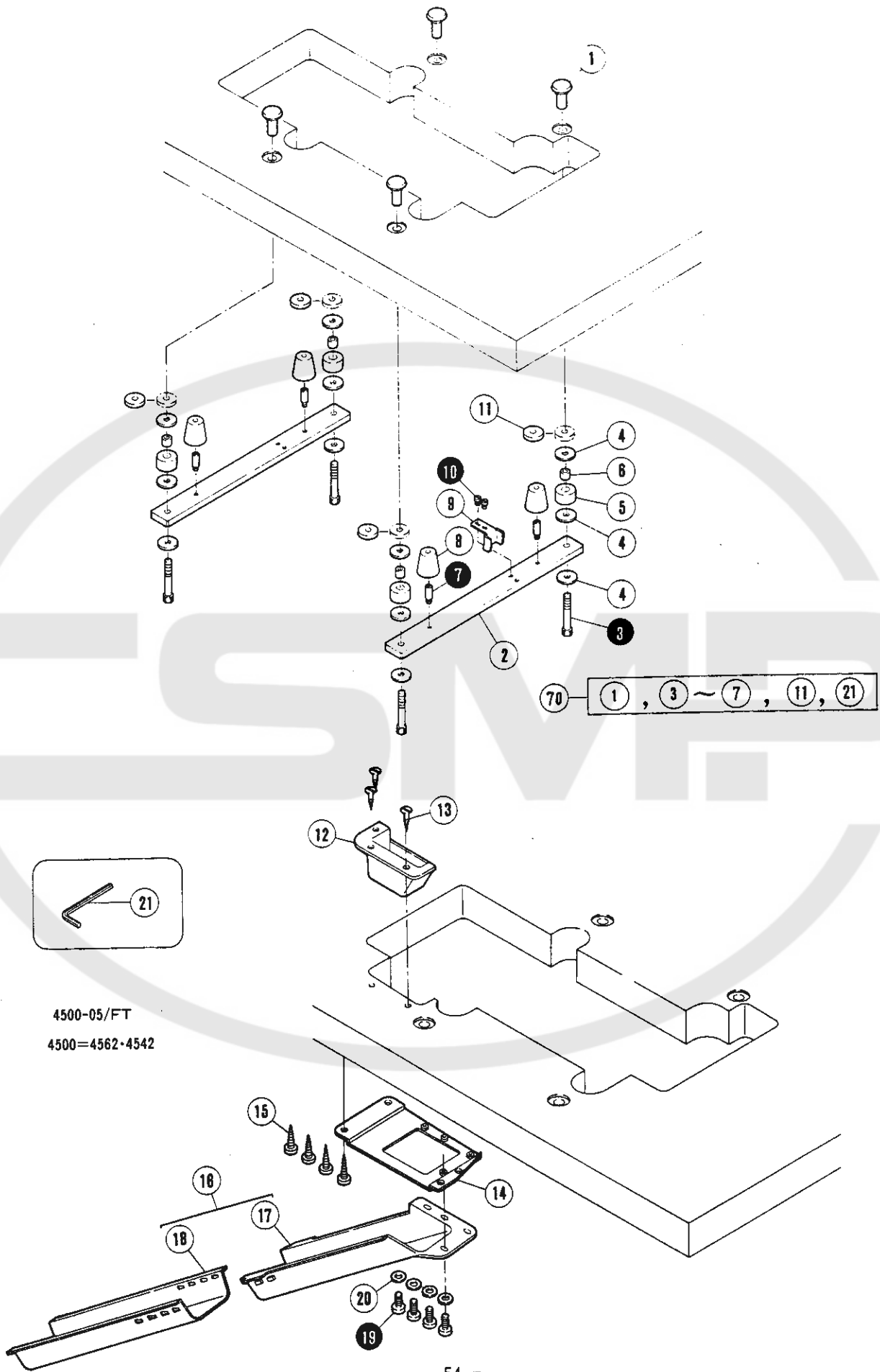

4500-05/FT
 4500=4562-4542

PARTS FOR SEMI-SUBMERGED INSTALLATION

REF. NO.	PART NO.	PFAFF-NO.	NAME	QT.
1	206336	09-009604-60	NUT	4
2	259000	09-400795-00	REST BOARD	2
3	4512	09-400788-00	SCREW	4
4	206337	09-009612-93	WASHER	12
5	205764	09-009612-87	CUSHION RUBBER	4
6	205765	09-009612-88	LINER	4
7	7093	09-400791-00	SCREW	4
8	206338	09-400794-00	CUSHION RUBBER	4
9	206329	09-400793-00	TREADLE CHAIN GUIDE	1
10	7027	11-108222-15	SCREW	2
11	205467	09-009603-76	SPACER	4
12	306473-JA	09-400796-00	WASTE CHUTE TOP	1
13	4904	09-009612-31	SCREW	3
14	306474A	09-009828-66	BRACKET	1
	306474	09-400797-00	BRACKET	02 1 101088
15	4905	09-009612-32	SCREW	4
16	9050	09-009815-93	WASTE CHUTE SET	1
17	205468-JA	09-009603-77	WASTE CHUTE TOP	1
18	205469-JA	09-009603-78	WASTE CHUTE TOP (B)	1
19	4012	09-009612-25	SCREW	4
20	200098	09-009048-70	WASHER	4
21	272	09-009612-01	ALLEN KEY/6MM	1

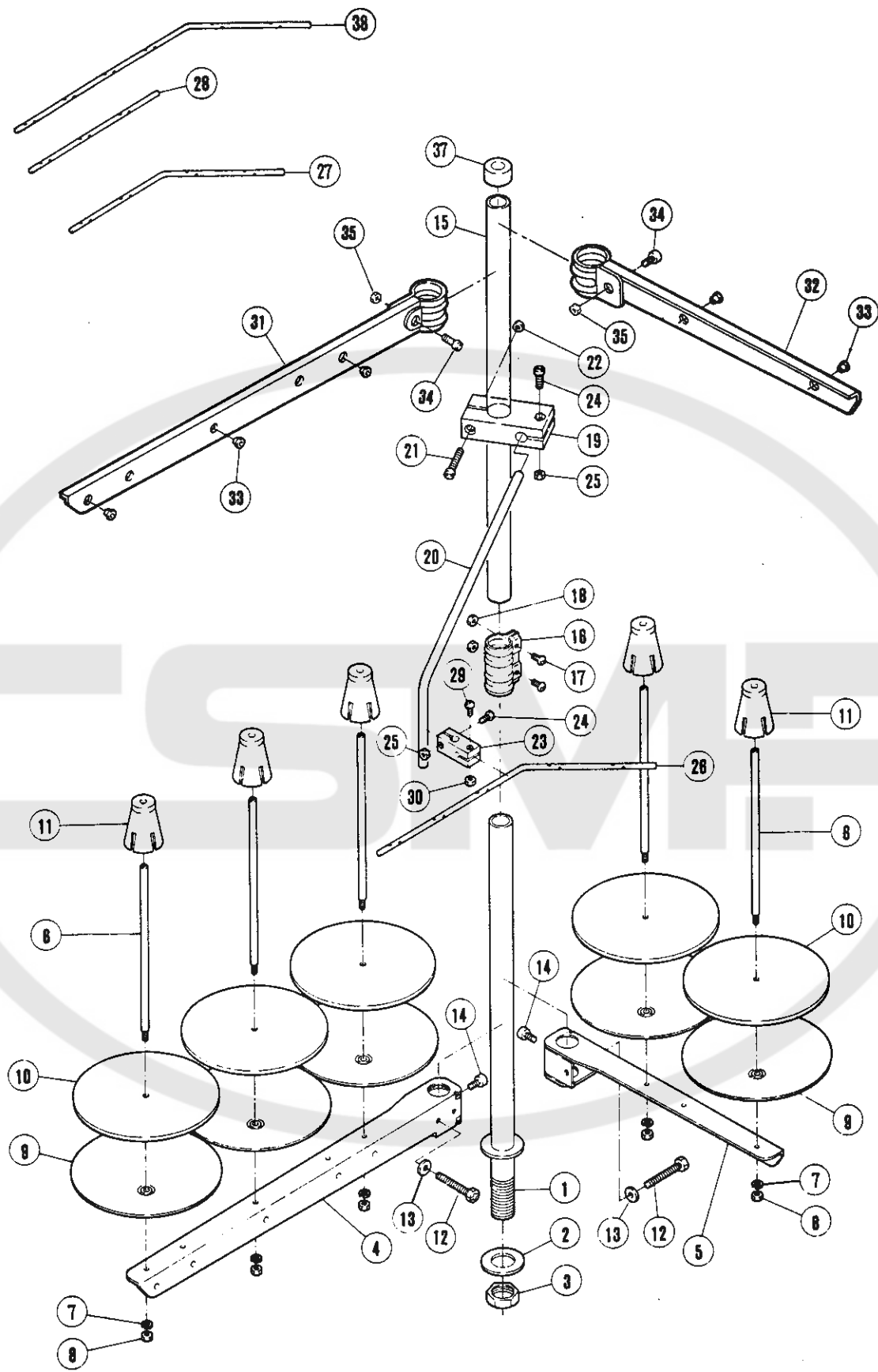

THREAD STAND

REF. NO.	PART NO.	PFAFF-NO.	NAME	QT.	QT.	QT.	QT.
	486-9C	09-400776-00	THREAD STAND ASS. (6-SPOOLS)	1			
	486A9C	09-009612-04	THREAD STAND ASS. (5-SPOOLS)		1		
	486B9C	09-400773-00	THREAD STAND ASS. (4-SPOOLS)			1	
	486C9C	09-400774-00	THREAD STAND ASS. (3-SPOOLS)				1
1	503-CA	09-009815-12	THREAD STAND ROD (LOWER)	1	1	1	1
2	509	09-400784-00	WASHER	1	1	1	1
3	5476	09-009612-45	NUT	1	1	1	1
4	505-CA	09-400781-00	BRACKET	2	1		1
5	505ACA	09-400780-00	BRACKET		1	2	
6	380A	09-009807-04	SPOOL PIN	6	5	4	3
7	201252	09-009050-73	SPRING WASHER	6	5	4	3
8	4803	09-009612-30	NUT	6	5	4	3
9	381-CA	09-009612-14	SPOOL TRAY	6	5	4	3
10	507	09-400783-00	CUSHION	6	5	4	3
11	382-CA	09-009815-13	SPOOL RETAINING FIN	6	5	4	3
12	7102	09-400792-00	SCREW	2	2	2	1
13	512	09-400785-00	WASHER	2	2	2	1
14	4022	09-400787-00	SCREW	2	2	2	1
15	502-CA	09-009815-14	THREAD STAND ROD (UPPER)	1	1	1	1
16	504-CA	09-009815-15	JOINT	1	1	1	1
17	4021	09-400786-00	SCREW	2	2	2	2
18	4805	09-400065-00	NUT	2	2	2	2
19	383-CA	09-009815-16	BRACKET	1	1	1	1
20	384	09-009612-17	THREAD GUIDE BAR ROD	1	1	1	1
21	4014	09-009612-27	SCREW	1	1	1	1
22	4803	09-009612-30	NUT	1	1	1	1
23	233-CA	09-009619-24	HOLDER	1	1	1	1
24	4012	09-009612-25	SCREW	2	2	2	2
25	4803	09-009612-30	NUT	2	2	2	2
26	293A	09-400768-00	THREAD GUIDE BAR (5-SPOOLS)		1		
27	293B	09-009823-35	THREAD GUIDE BAR (4-SPOOLS)			1	
28	293C	09-400770-00	THREAD GUIDE BAR (3-SPOOLS)				1
29	4012	09-009612-25	SCREW	1	1	1	1
30	4803	09-009612-30	NUT	1	1	1	1
31	527-CA	09-009826-63	BRACKET	2	1		1
32	505-CA	09-400781-00	BRACKET	01			110687
	527ACA	09-009826-64	BRACKET		1	2	
	505ACA	09-400780-00	BRACKET	01			3 110687
33	506	09-400782-00	THREAD GUIDE	6	5	4	1
34	4117	09-009826-65	SCREW	2	2	2	
35	7102	09-400792-00	SCREW	01			110687
	4805	09-400065-00	NUT	2	2	2	1
	512	09-400785-00	WASHER	01			110687
36	4022	09-400787-00	SCREW	10			110687
37	386	09-009612-19	ROD CAP	1	1	1	1
70	293	09-009619-27	THREAD GUIDE BAR (6-SPOOLS)	1			

Notice) Parts with mark * are not for sale.

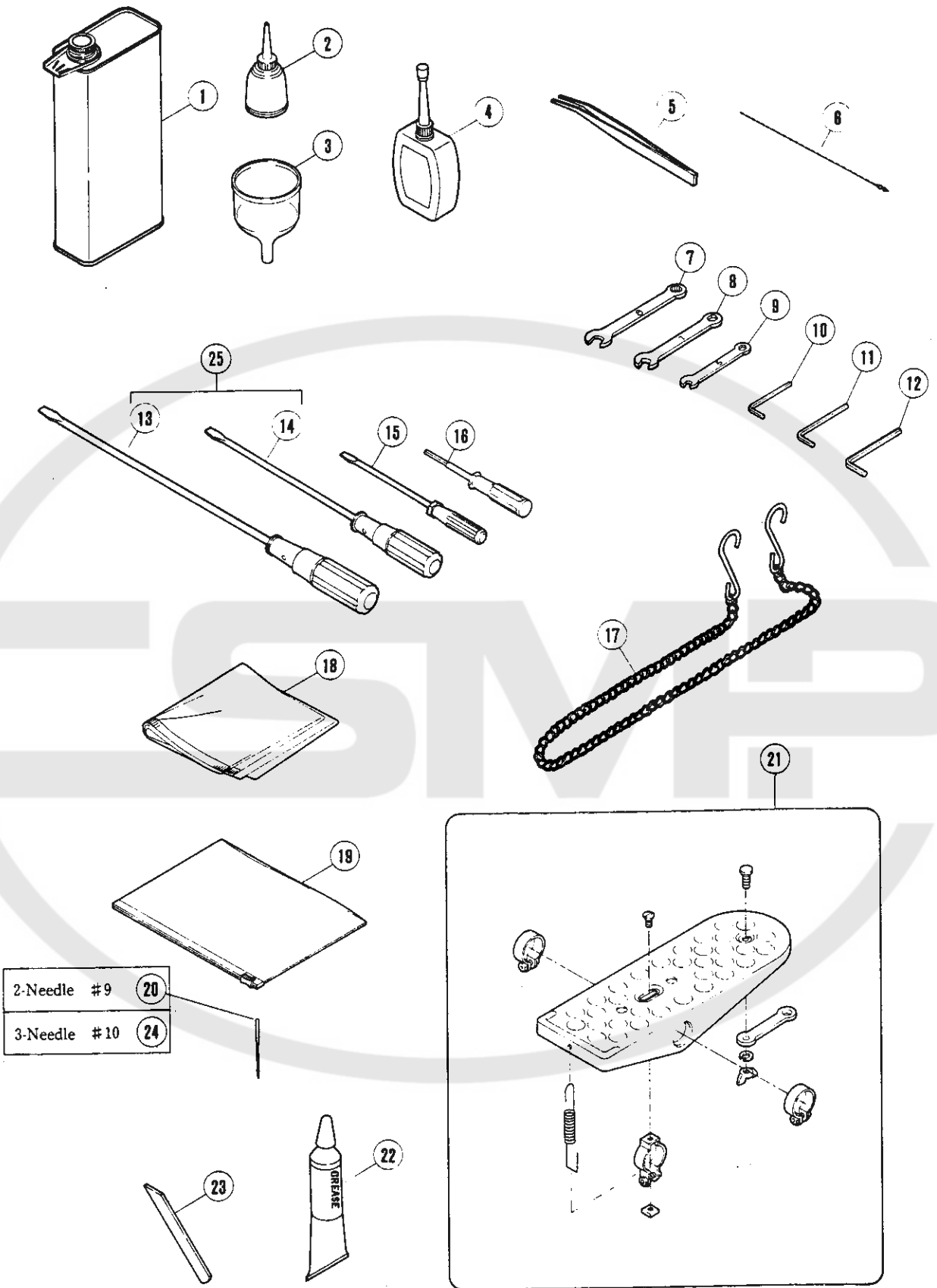

ACCESSORIES

REF. NO.	PART NO.	PFAFF-NO.	NAME	QT.
1	453	09-009734-78	OIL CONTAINER/1000CC	1
2	485	09-400030-00	OILER	1
3	484	09-400029-00	OIL FUNNEL	1
4	178	09-009600-03	CONTAINER - SILICONE	1
5	131	09-009815-08	TWEEZERS	1
6	153	09-009819-55	THREADING WIRE	1
7	285	09-009048-26	WRENCH/8MM	1
8	284	09-009048-25	WRENCH/7MM	1
9	282	09-009048-05	WRENCH/5MM	1
10	465	09-400025-00	ALLEN KEY/2.5MM	1
11	399	09-400024-00	ALLEN KEY/3MM	1
12	271	09-400017-00	ALLEN KEY/4MM	1
13	127	91-029007-91	SCREWDRIVER (LARGE)	1
14	128	91-029480-91	SCREWDRIVER (MEDIUM)	1
15	129	91-029946-91	SCREWDRIVER (SMALL)	1
16	474	09-400026-00	ALLEN KEY DRIVER/1.5MM	1
17	125	09-400002-00	CHAIN	1
18	908	09-400032-00	DUST COVER	1
19	482	09-400028-00	ACCESSORY BAG	1
*20	671B	49-016050-01	NEEDLE	1
21	480	09-009815-09	PEDAL	1
22	138	09-400007-00	GREASE	1
23	204161	09-009053-33	LOWER KNIFE	1
*24	672B	49-016060-01	NEEDLE	1
25	9105	09-009823-11	SCREWDRIVER (LARGE. MEDIUM)	1

Notice) Parts with mark ※ are not for sale.

4562-01CA

GAUGE PARTS CONSTRUCTION CHART

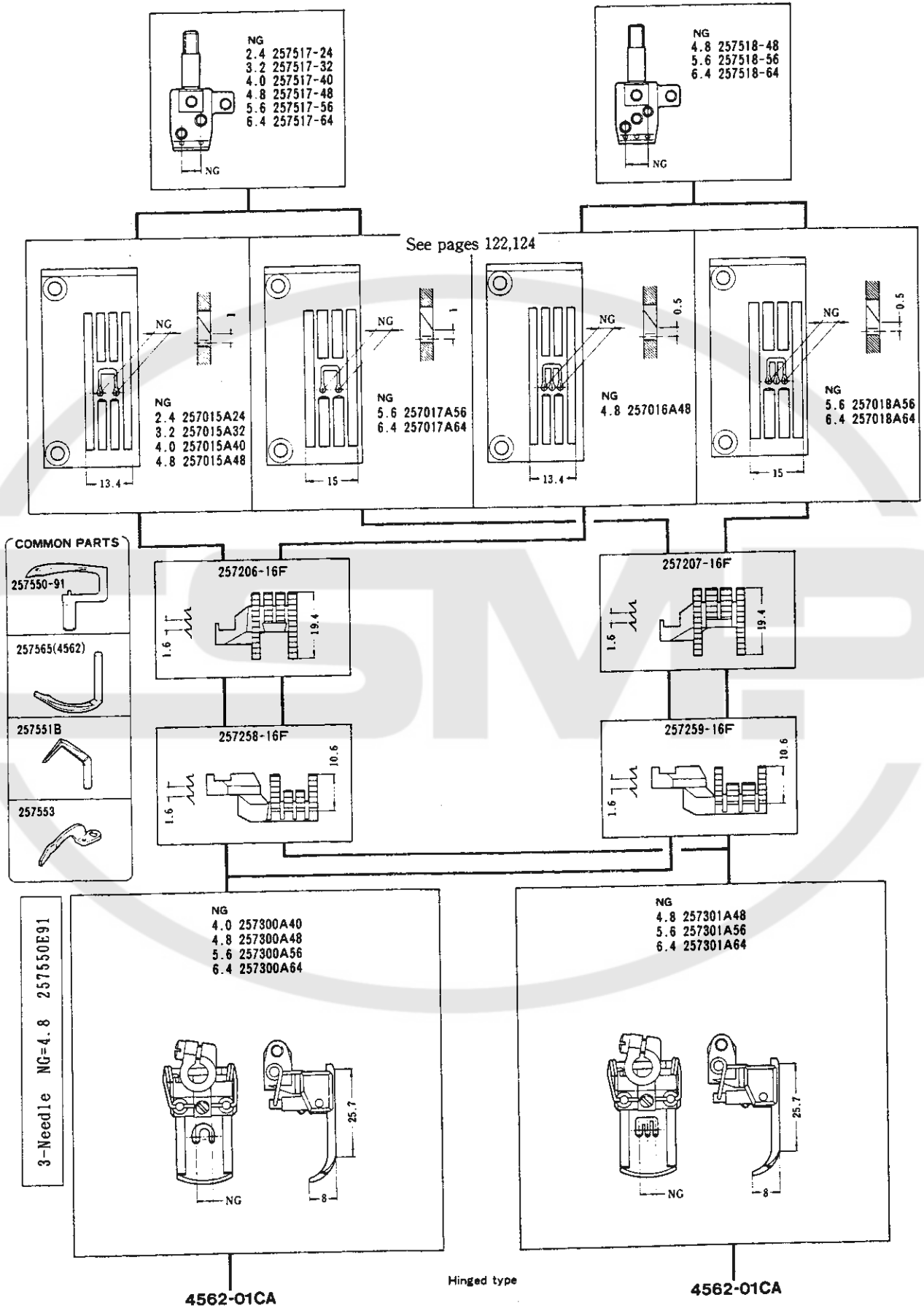

4542-01CA

GAUGE PARTS CONSTRUCTION CHART

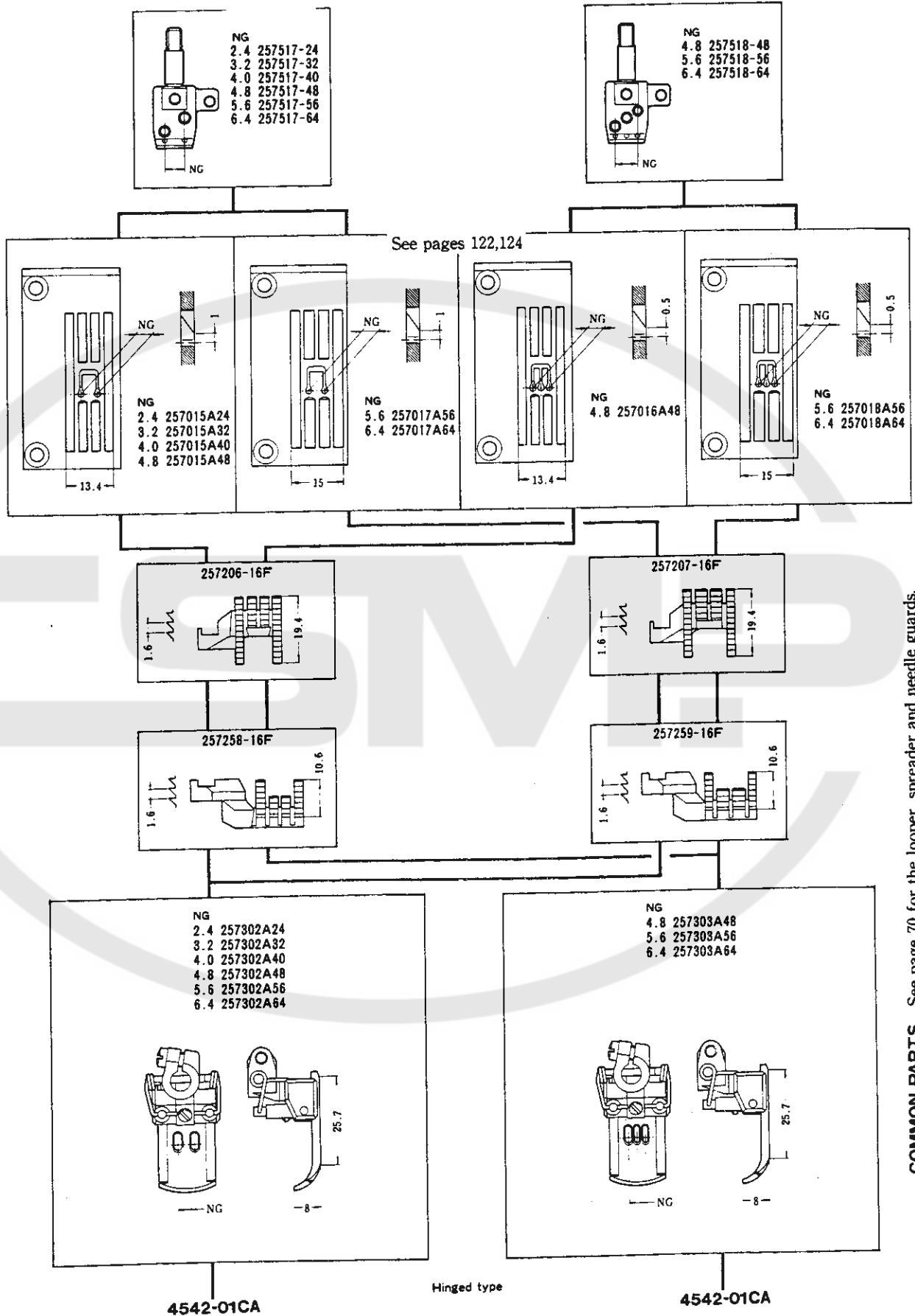

COMMON PARTS See page 70 for the looper, spreader and needle guards.

4562-01CB

GAUGE PARTS CONSTRUCTION CHART

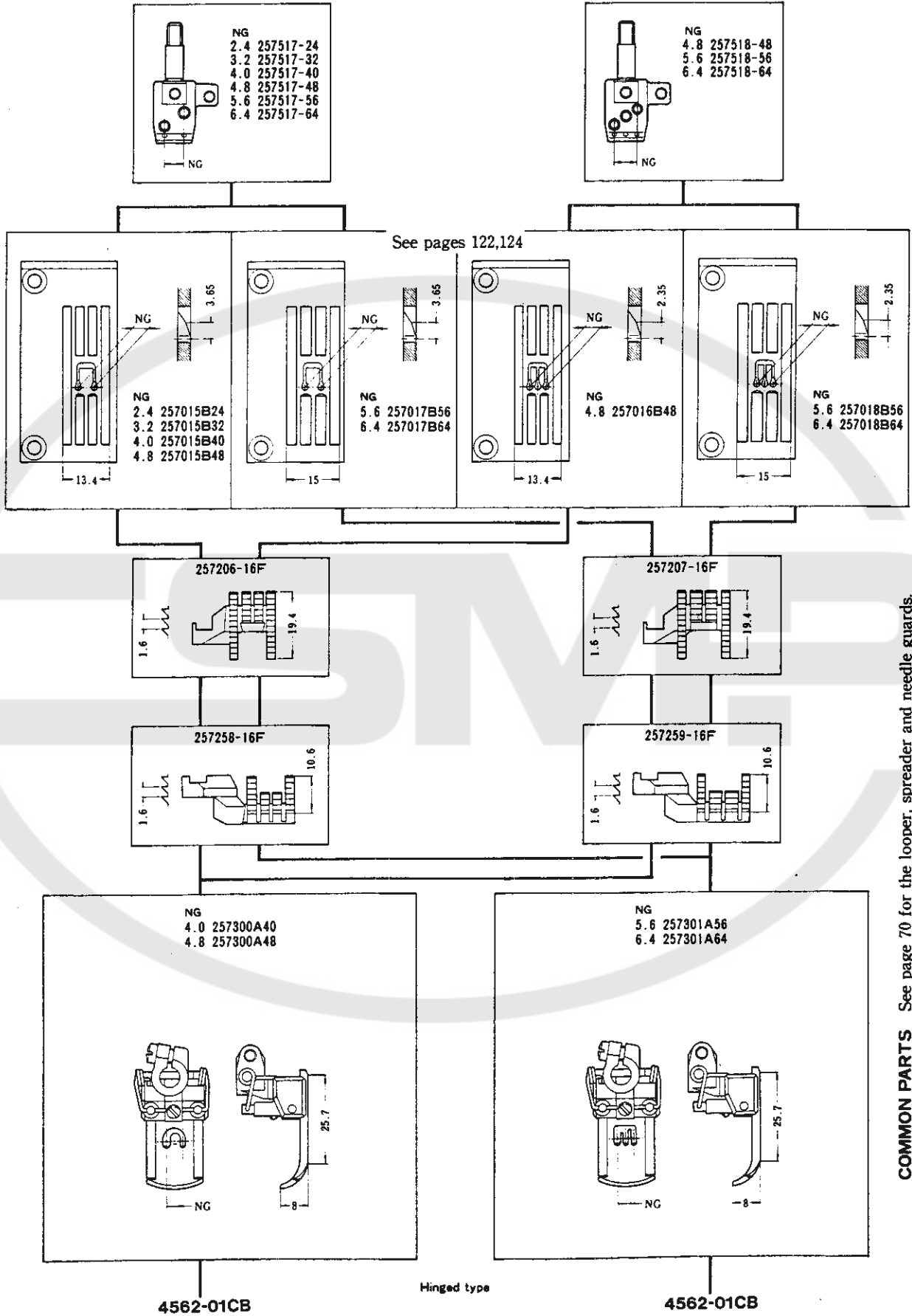

COMMON PARTS See page 70 for the looper, spreader and needle guards.

4542-01CB

GAUGE PARTS CONSTRUCTION CHART

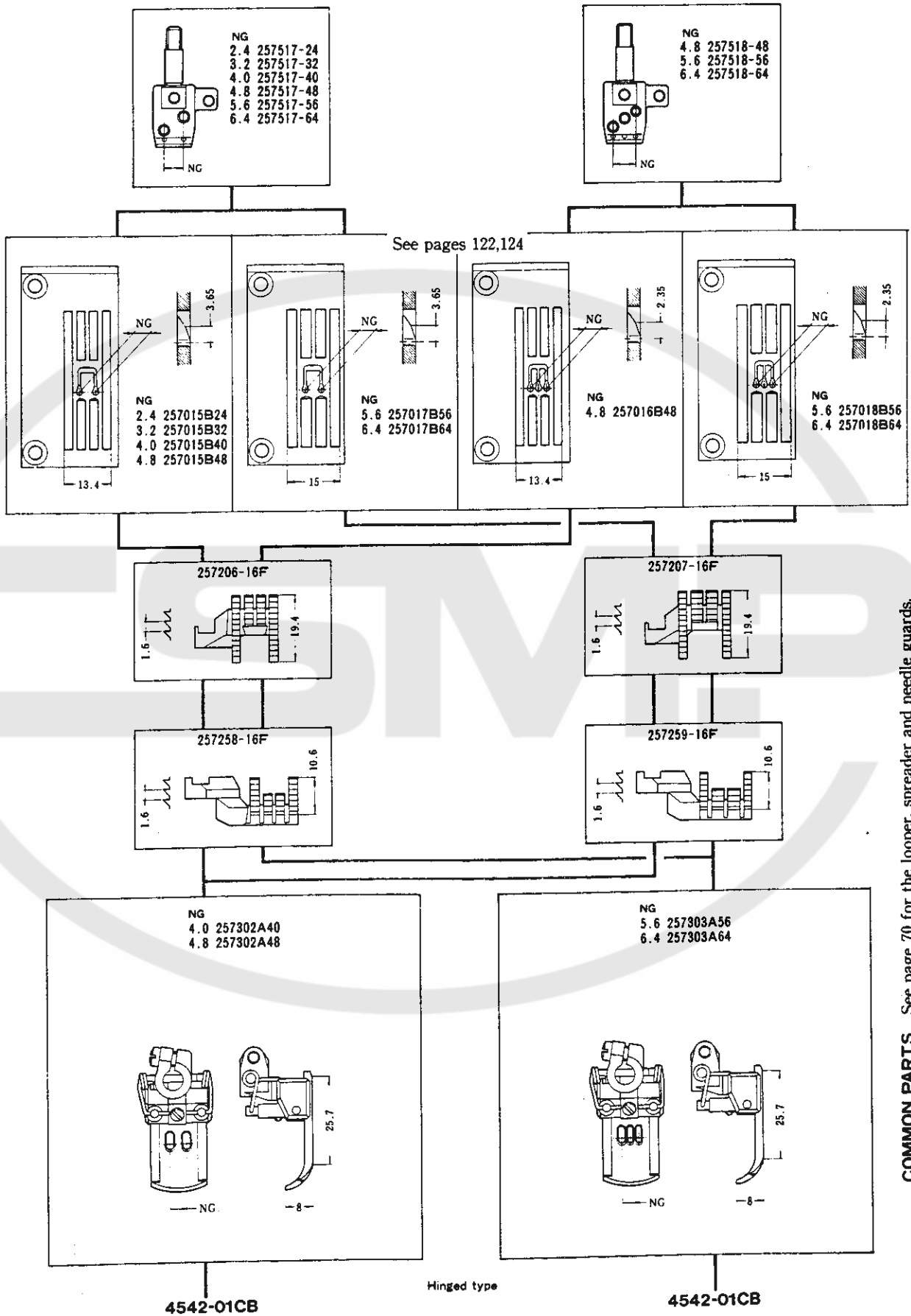

COMMON PARTS See page 70 for the looper, spreader and needle guards.

4562-01CC

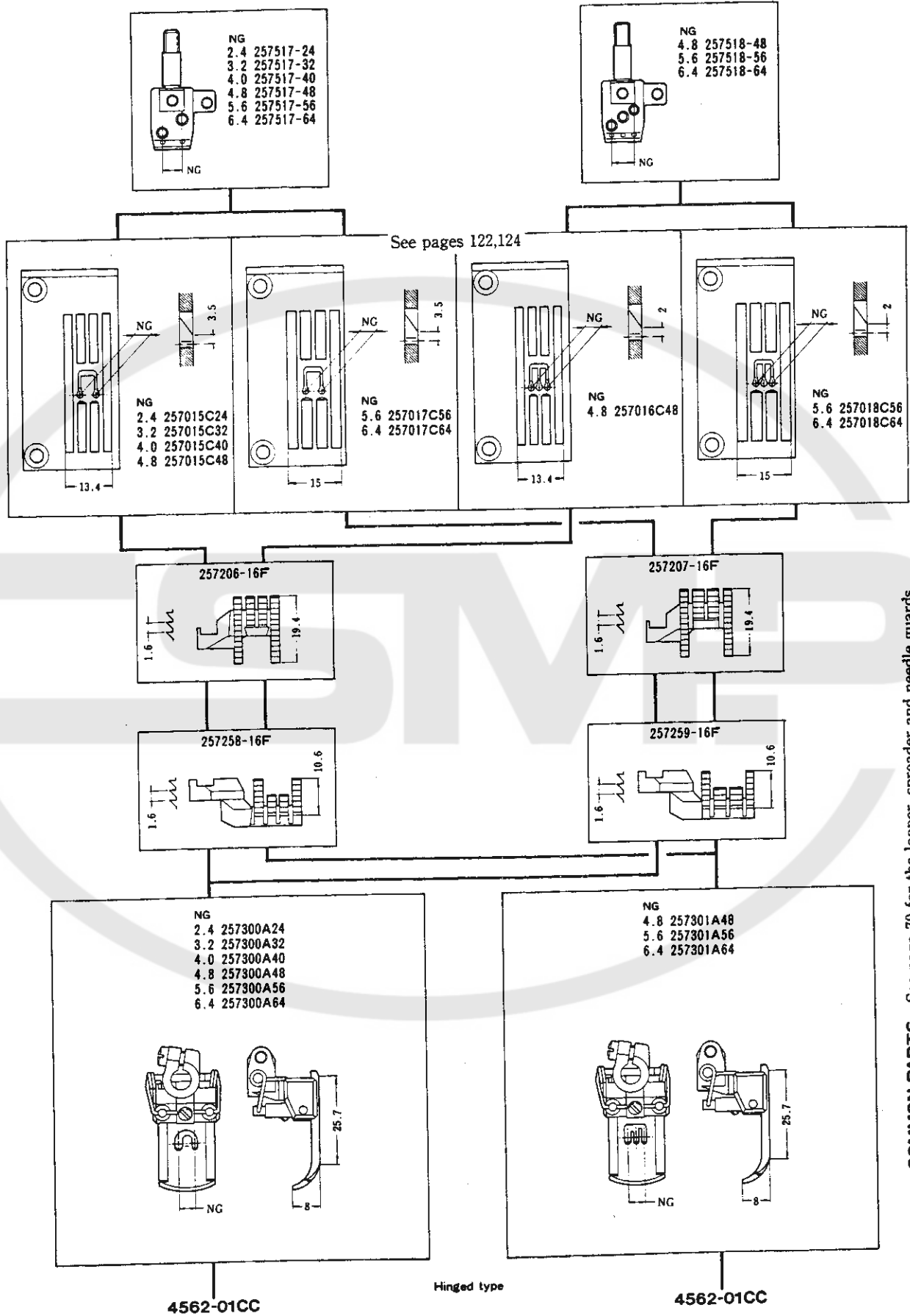

COMMON PARTS See page 70 for the looper, spreader and needle guards.

4542-01CC

GAUGE PARTS CONSTRUCTION CHART

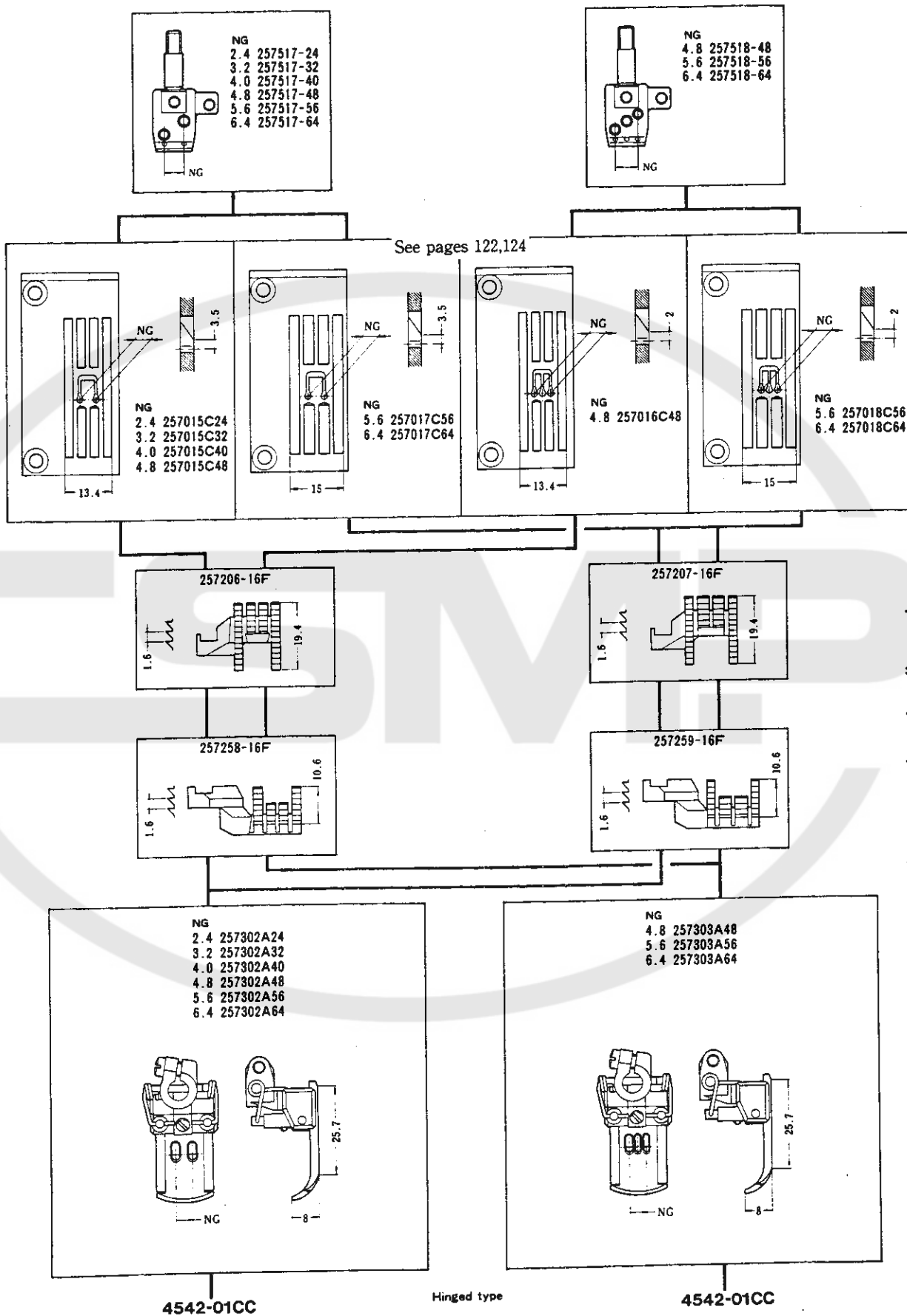

COMMON PARTS See page 70 for the looper, spreader and needle guards.

4542-01CC

Hinged type

4542-01CC

4562-02BA, BB, BC

GAUGE PARTS CONSTRUCTION CHART

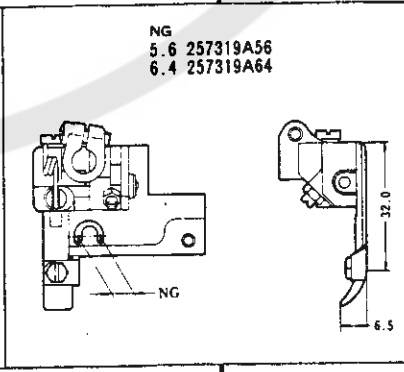
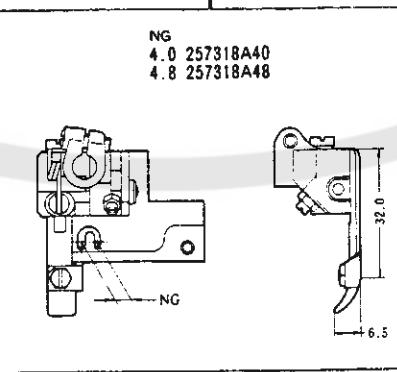
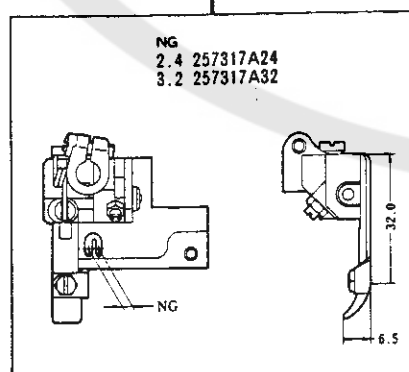
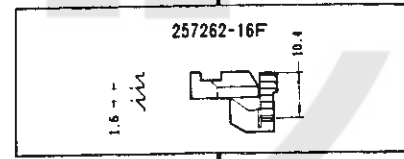
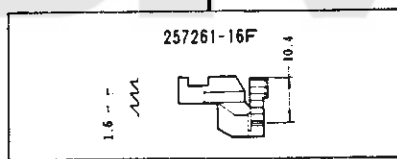
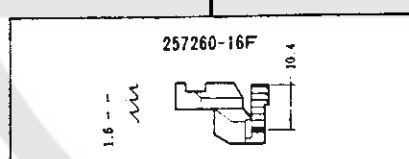
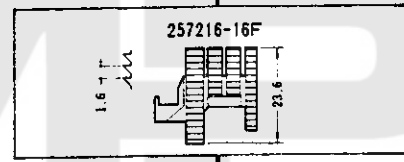
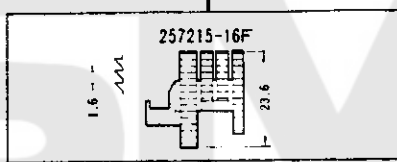
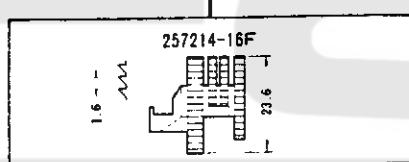
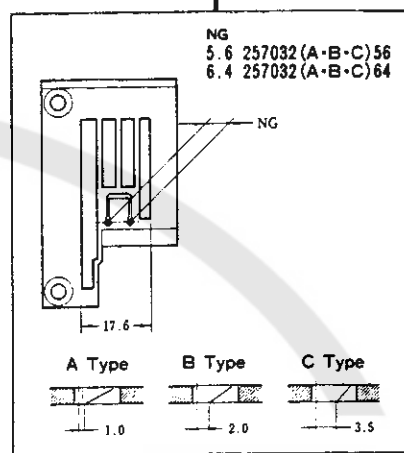
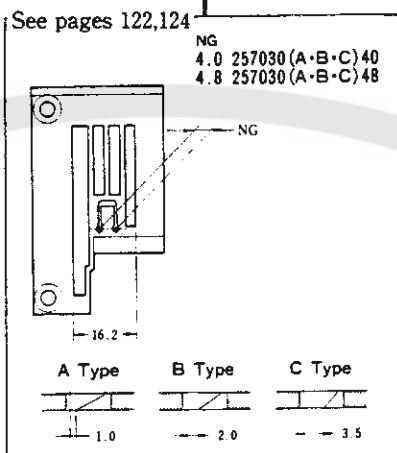
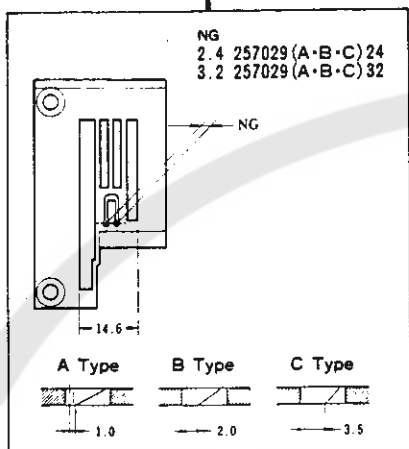
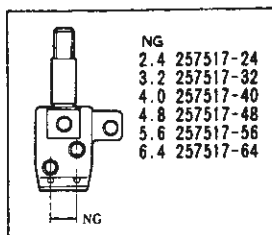

4562-02BA, BB, BC × 224 · 232

4562-02BA, BB, BC × 240 · 248

4562-02BA, BB, BC × 256 · 264

MACHINE	NEEDLE PLATE
4562-02BA	A TYPE
4562-02BB	B TYPE
4562-02BC	C TYPE

COMMON PARTS

See page 70 for the looper and needle guards.

4562-02BA, BB, BC

GAUGE PARTS CONSTRUCTION CHART

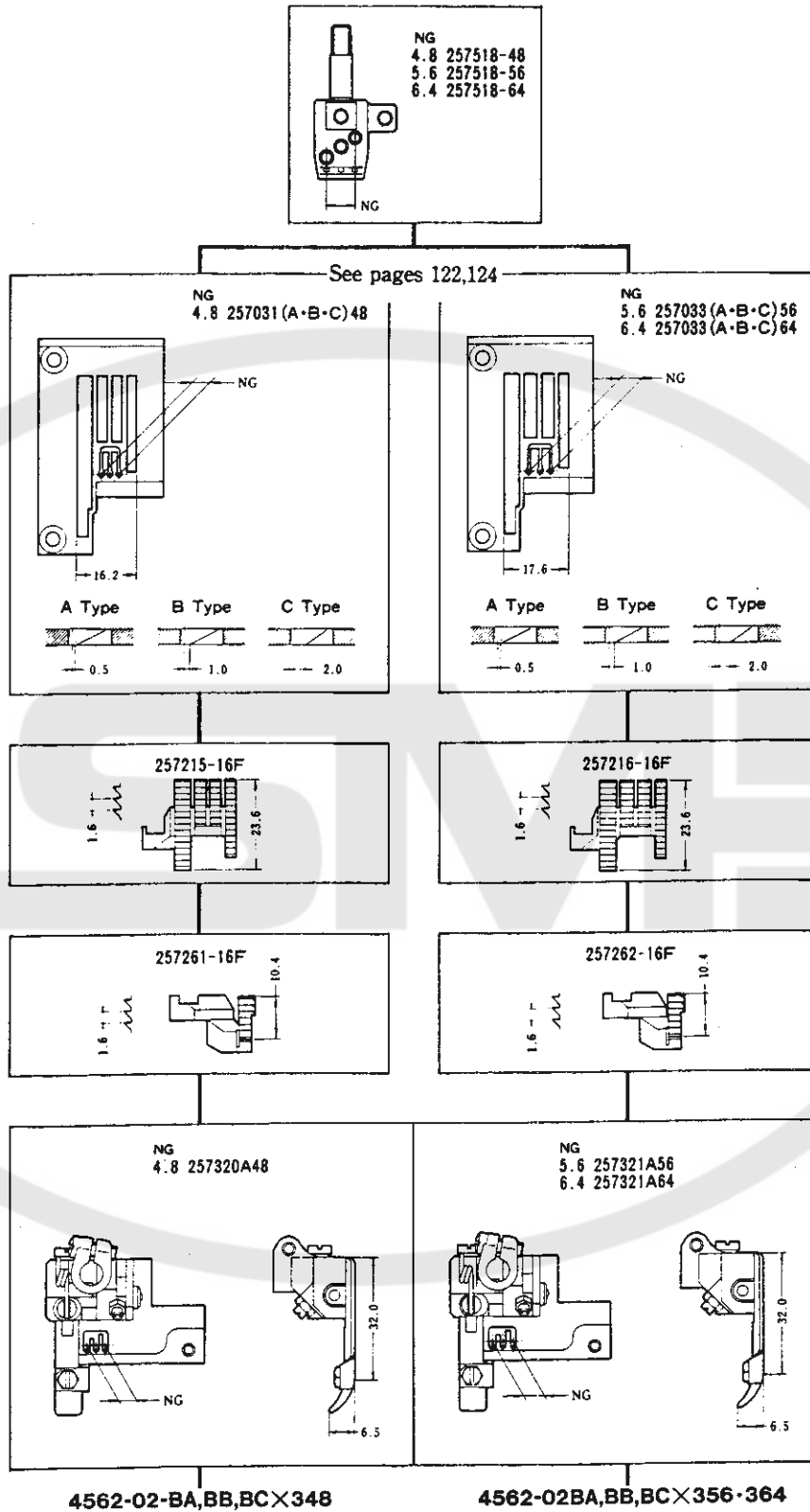

MACHINE	NEEDLE PLATE
4562-02BA	A TYPE
4562-02BB	B TYPE
4562-02BC	C TYPE

COMMON PARTS

See page 70 for the looper and needle guards.

4542-02BA, BB, BC

GAUGE PARTS CONSTRUCTION CHART

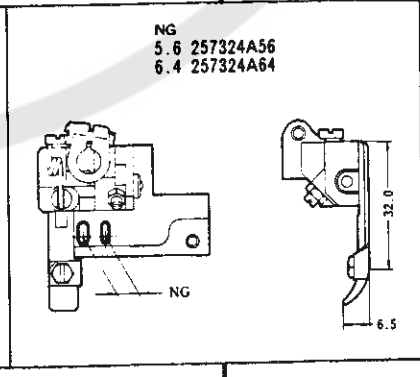
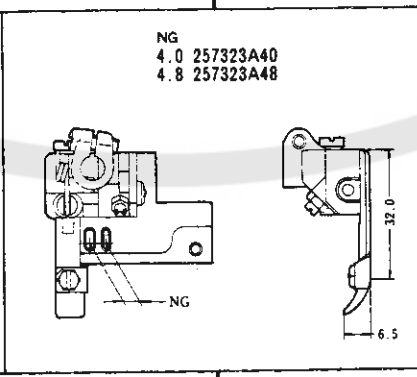
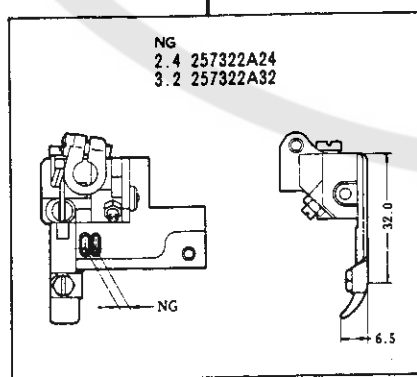
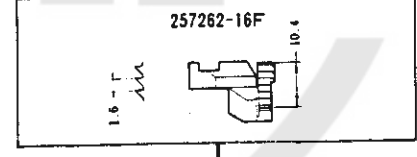
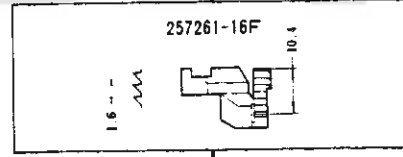
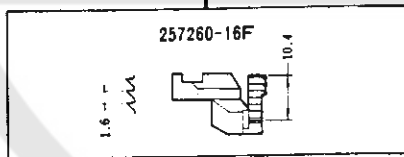
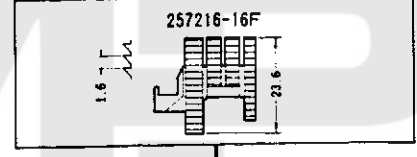
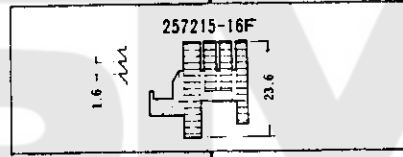
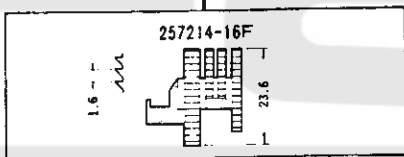
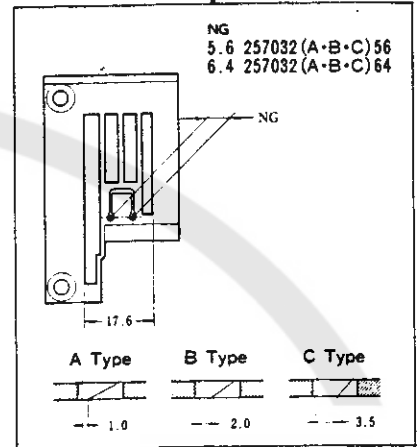
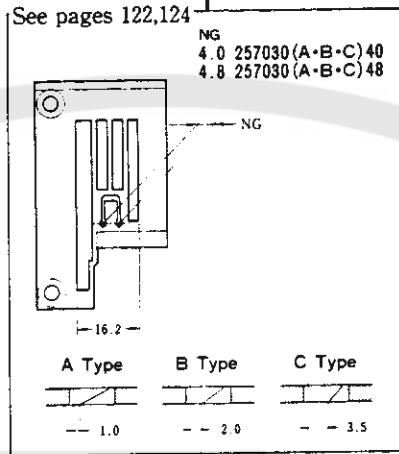
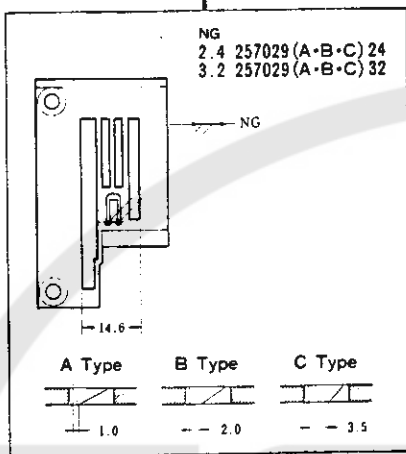
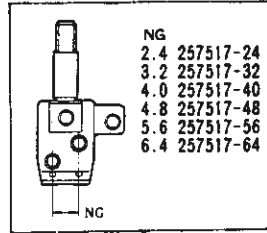

4542-02BA, BB, BC x 224-232

4542-02BA, BB, BC x 240-248

4542-02BA, BB, BC x 256-264

MACHINE	NEEDLE PLATE
4542-02BA	A TYPE
4542-02BB	B TYPE
4542-02BC	C TYPE

COMMON PARTS

See page 70 for the looper and needle guards.

4542-02BA, BB, BC

GAUGE PARTS CONSTRUCTION CHART

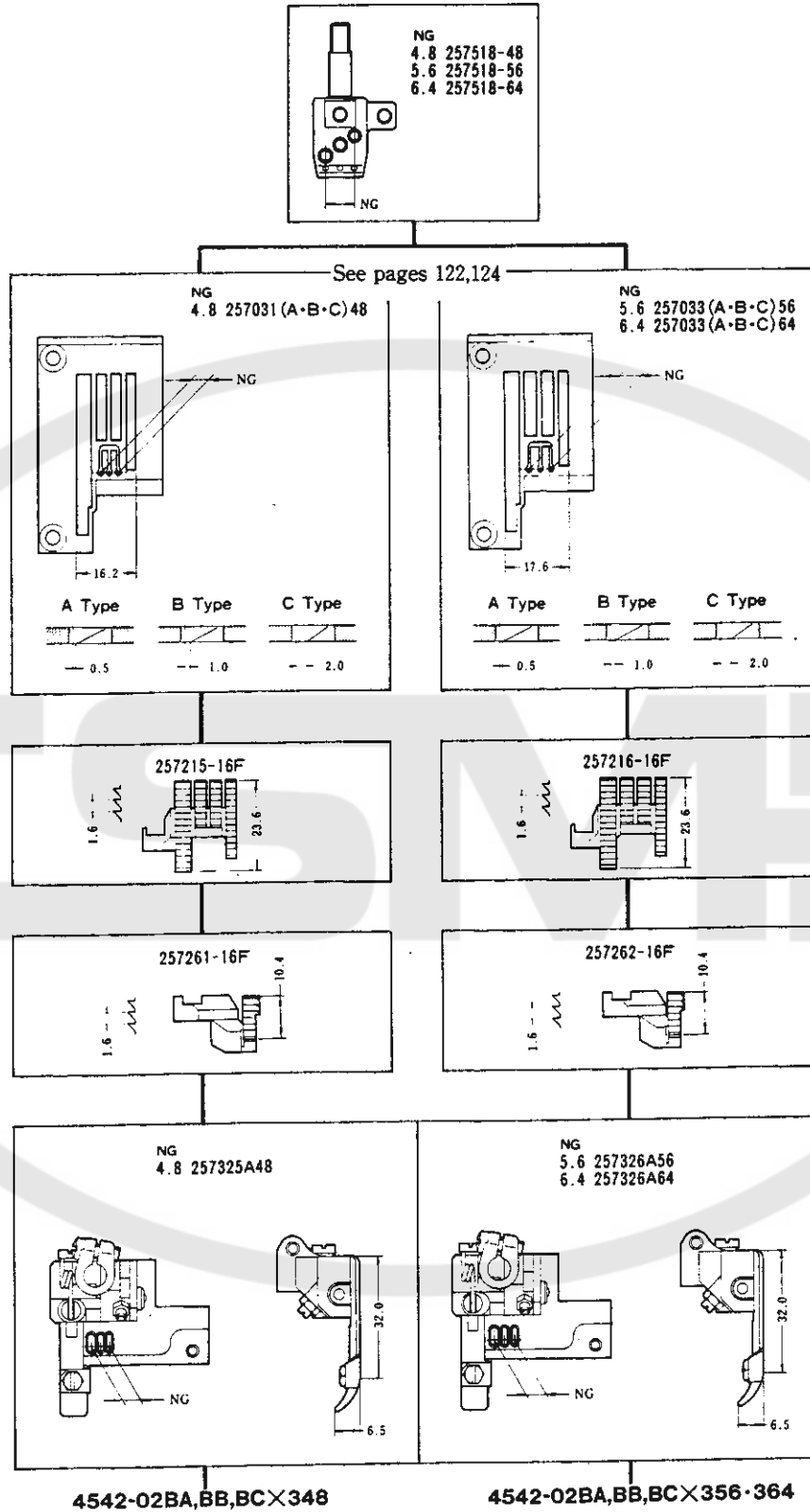

MACHINE	NEEDLE PLATE
4542-02BA	A TYPE
4542-02BB	B TYPE
4542-02BC	C TYPE

COMMON PARTS

See page 70 for the looper and needle guards.

4562-03AB(OLD)

GAUGE PARTS CONSTRUCTION CHART

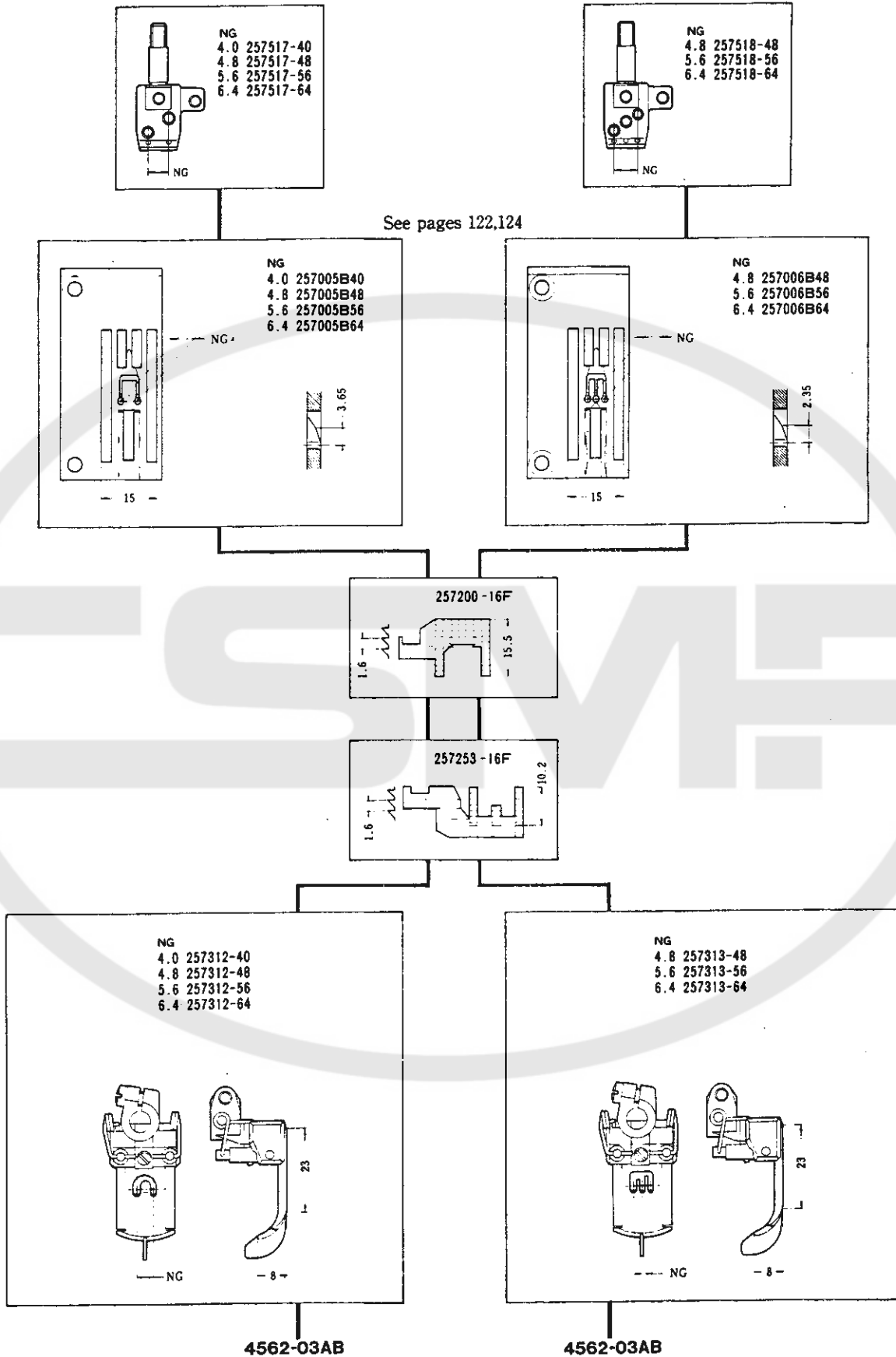

4542-03AB(OLD)

GAUGE PARTS CONSTRUCTION CHART

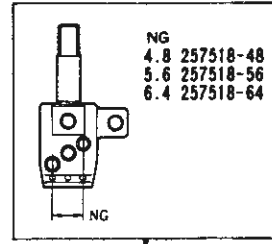
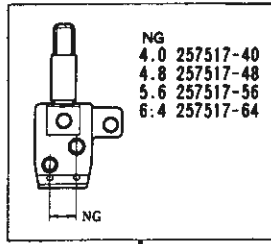

See pages 122,124

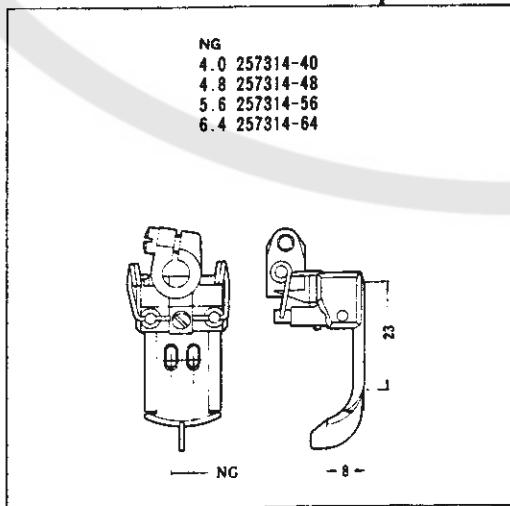
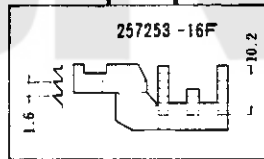
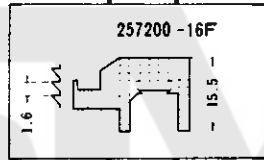
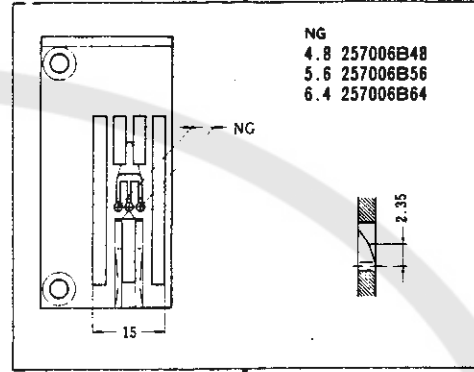
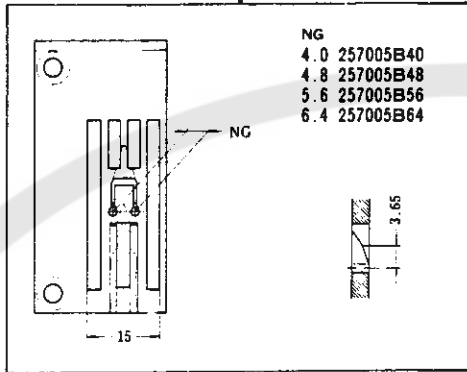

4542-03AB

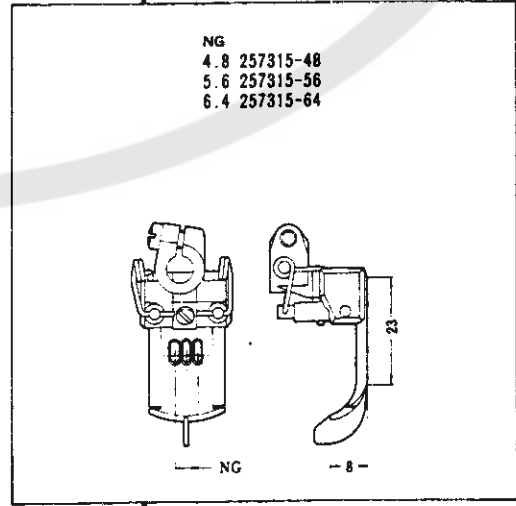

4542-03AB

COMMON PARTS See page 70 for the loop, spreader and needle guards.

4562-03AC(OLD)

GAUGE PARTS CONSTRUCTION CHART

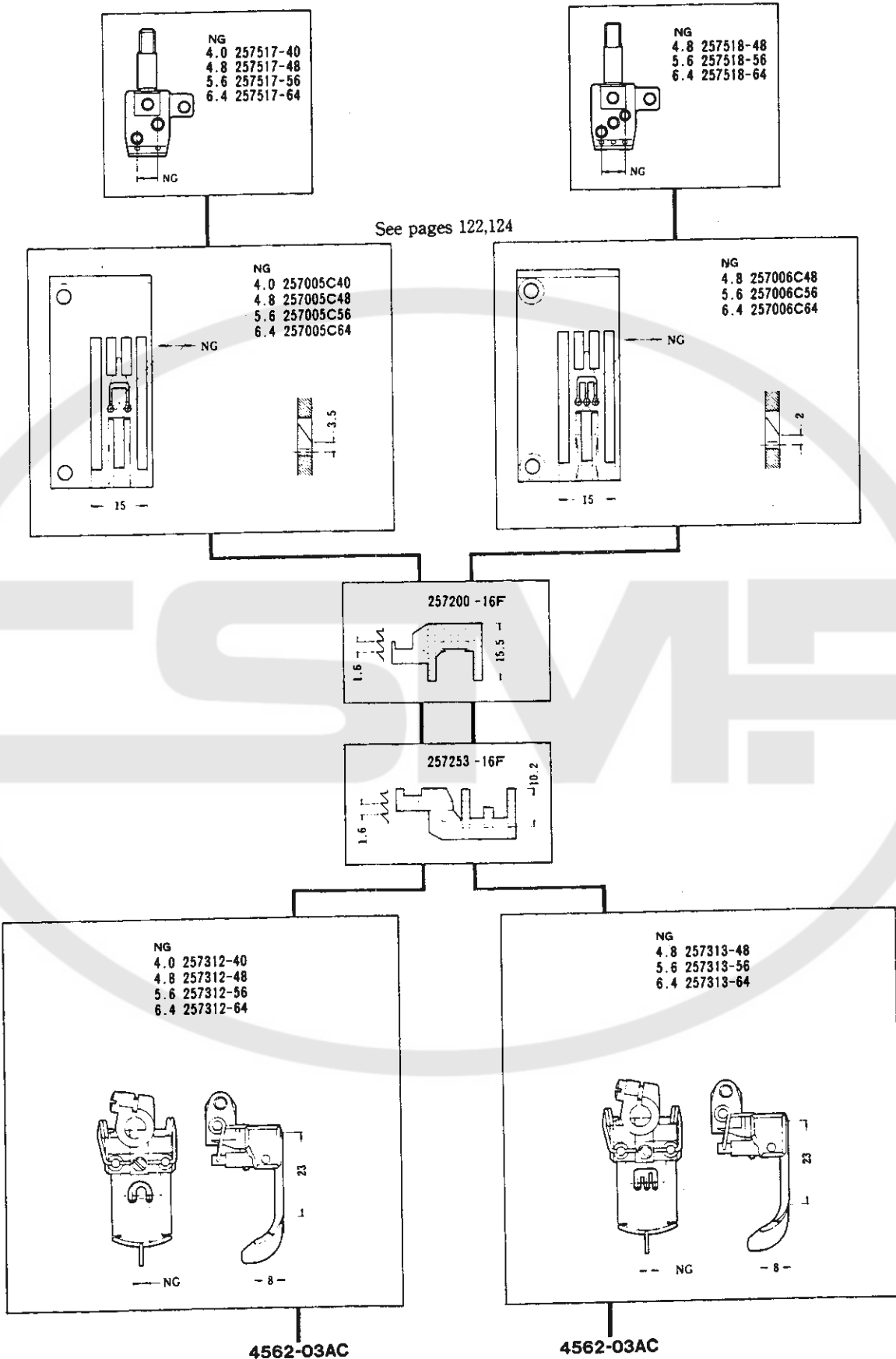

4542-03AC(OLD)

GAUGE PARTS CONSTRUCTION CHART

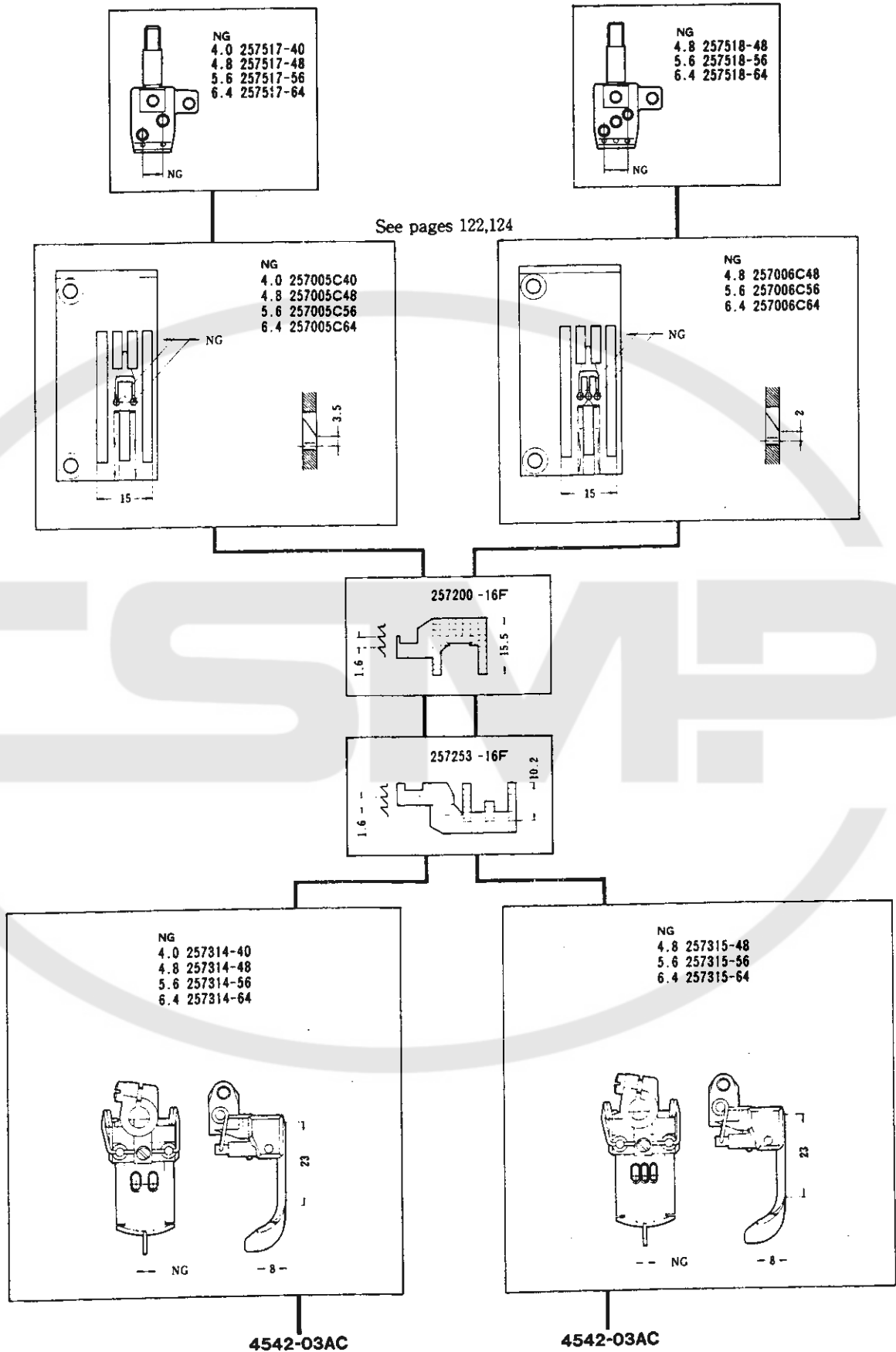

COMMON PARTS See page 70 for the looper, spreader and needle guards.

4562-03BB(OLD)

GAUGE PARTS CONSTRUCTION CHART

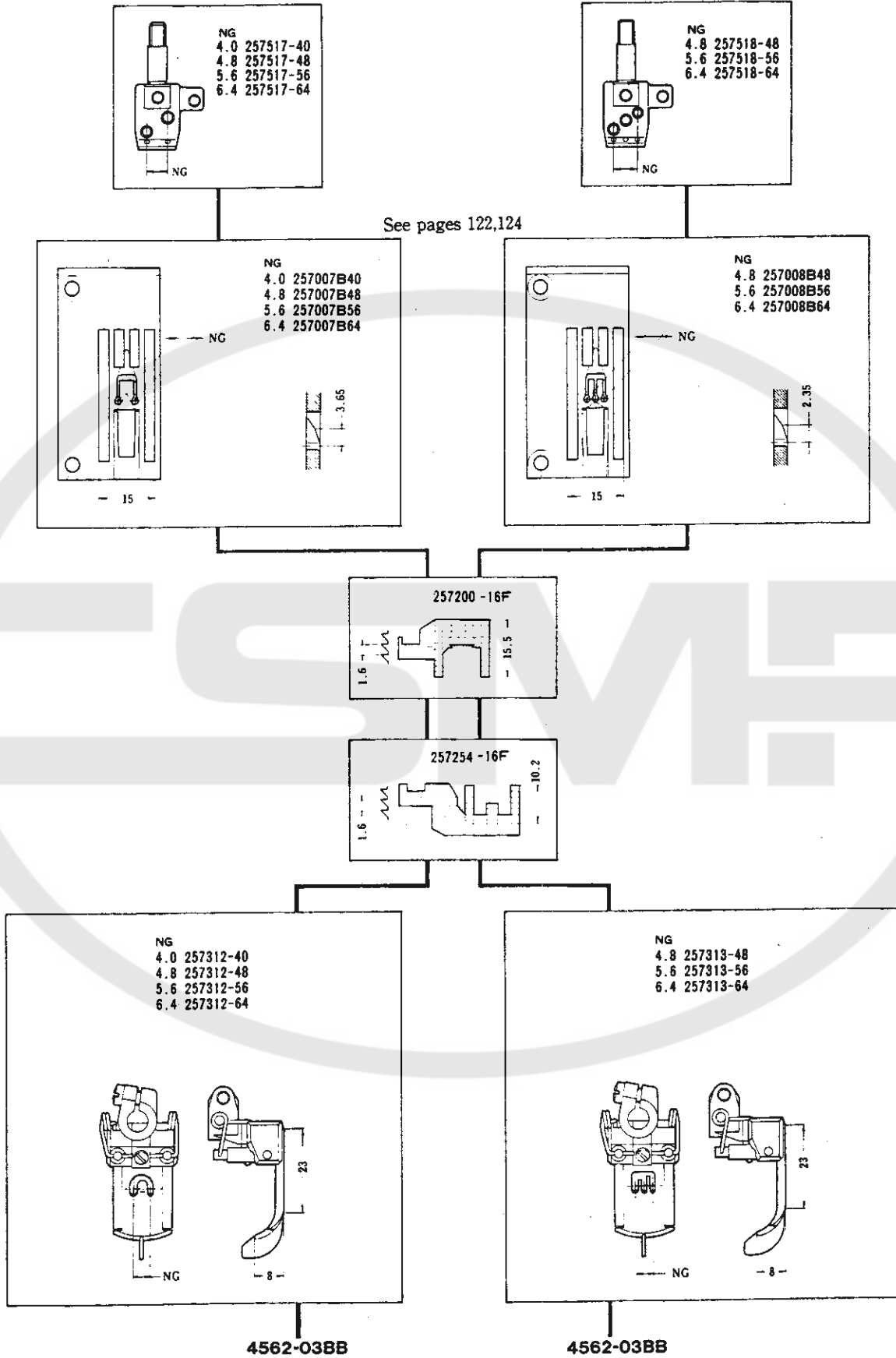

4542-03BB(OLD)

GAUGE PARTS CONSTRUCTION CHART

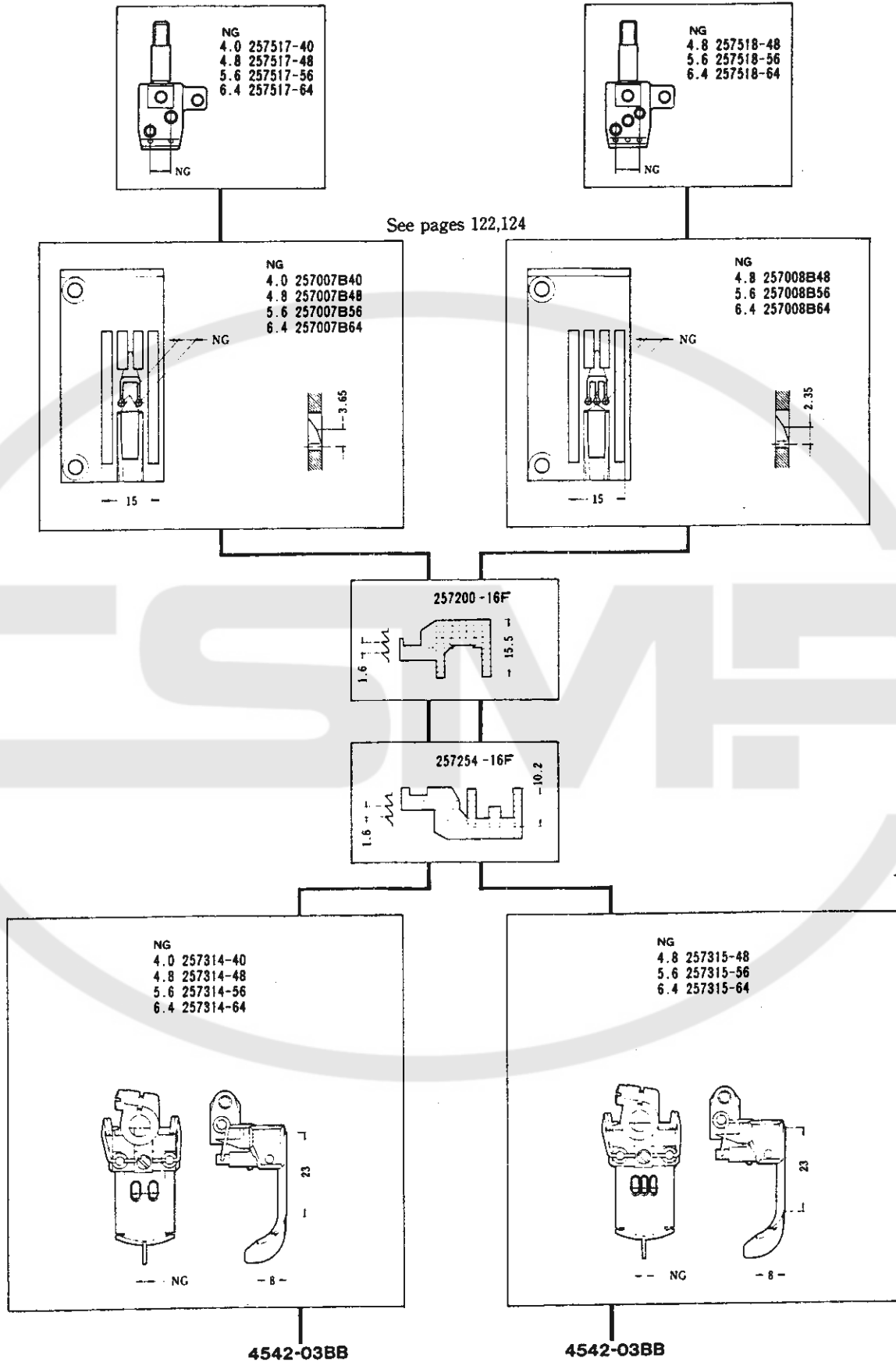

4562-03BC(OLD)

GAUGE PARTS CONSTRUCTION CHART

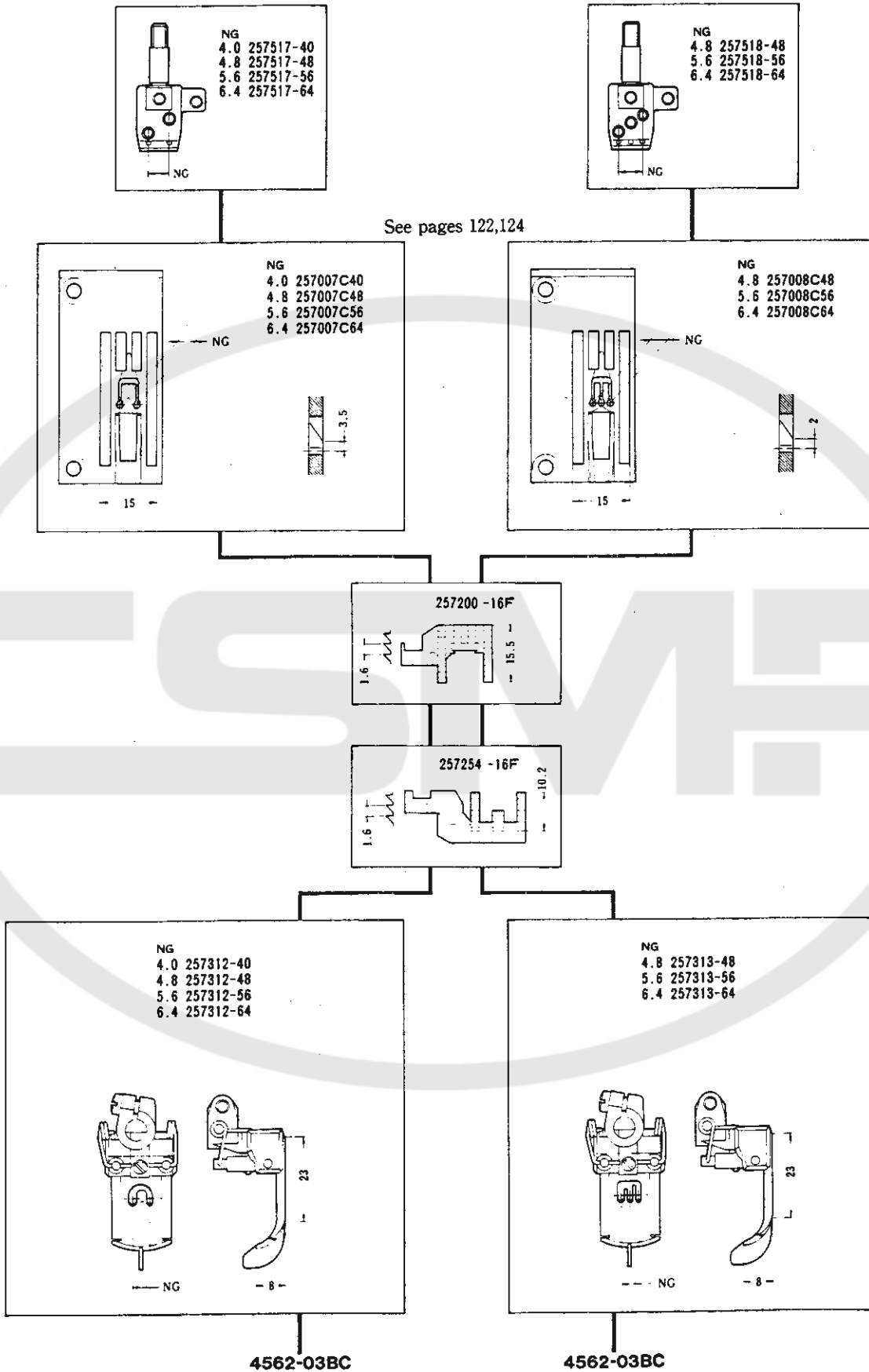

4542-03BC(OLD)

GAUGE PARTS CONSTRUCTION CHART

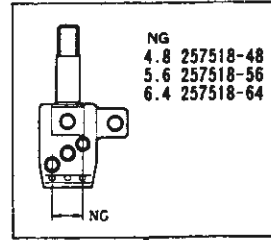
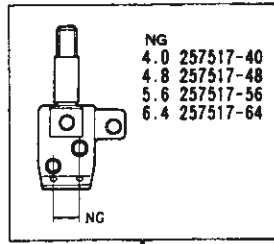

See pages 122,124

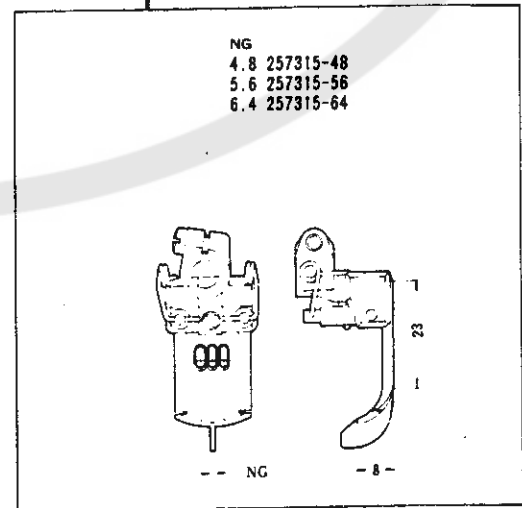
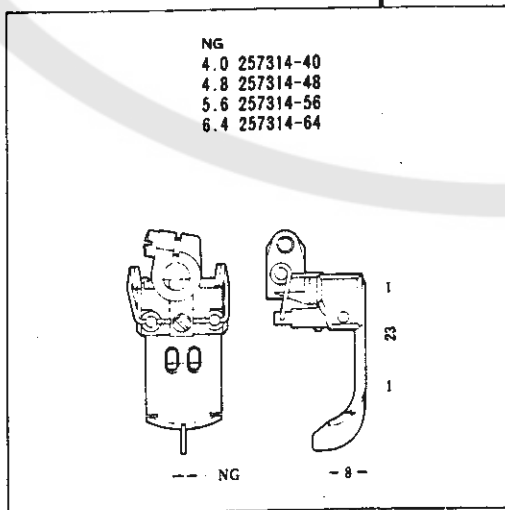
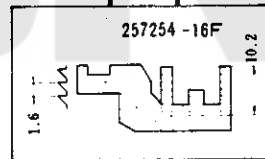
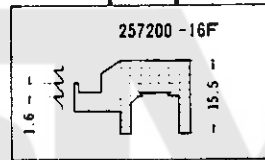
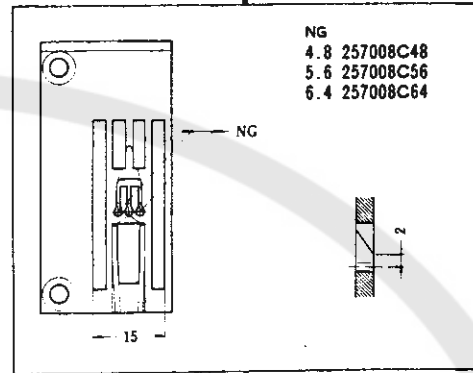
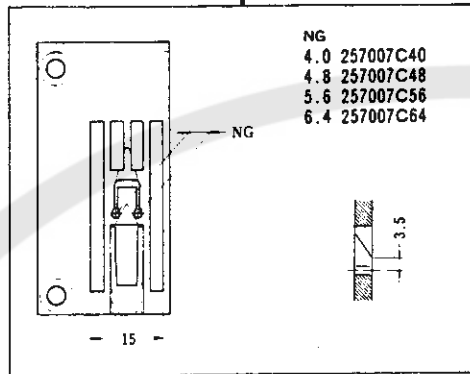

4542-03BC

4542-03BC

COMMON PARTS See page 70 for the looper, spreader and needle guards.

4562-03DB·DC

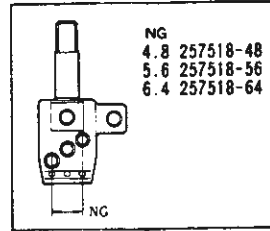
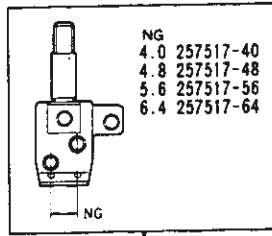

See pages 122,124

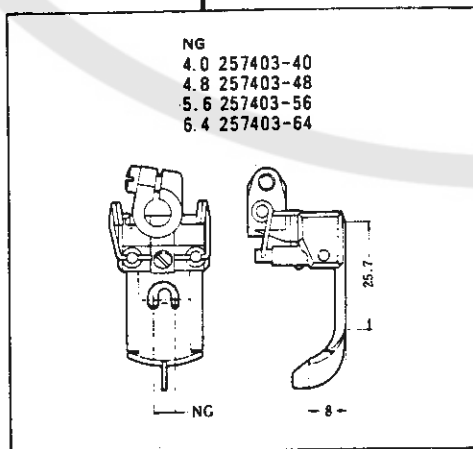
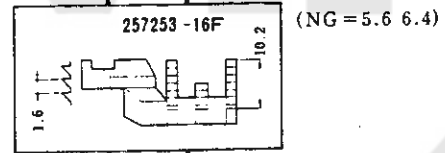
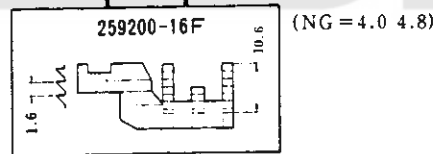
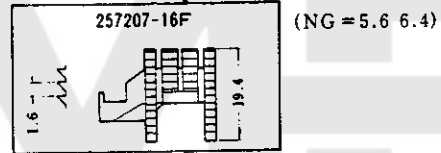
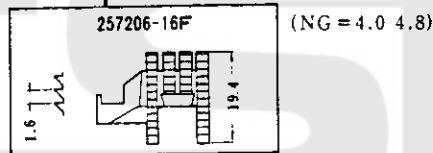
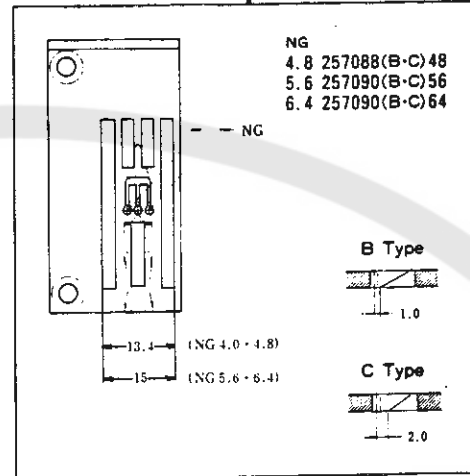
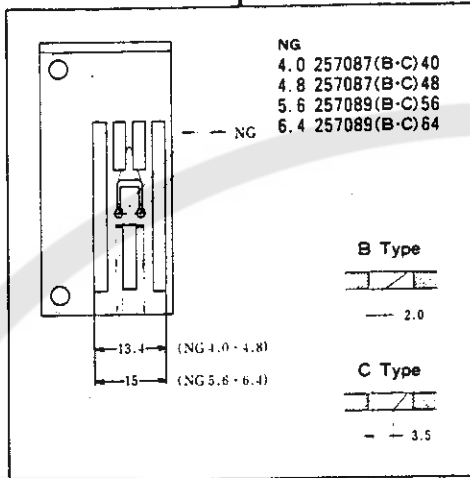

4562-03DB·DC

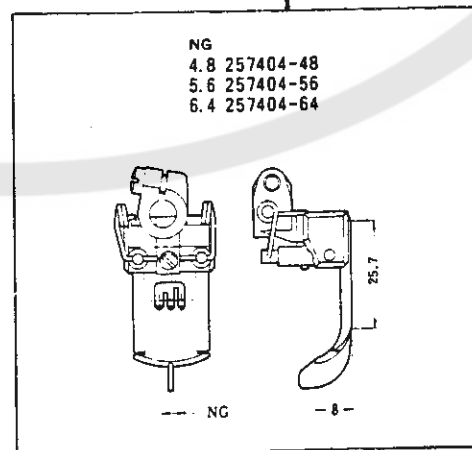

4562-03DB·DC

MACHINE	NEEDLE PLATE
4562-03DB	B TYPE
4562-03DC	C TYPE

COMMON PARTS

See page 70 for the looper and needle guards.

4542-03DB·DC

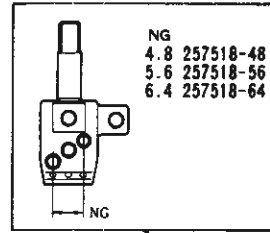
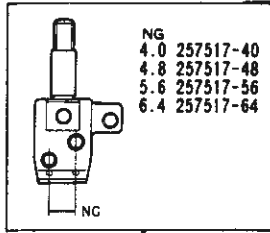

See pages 122,124

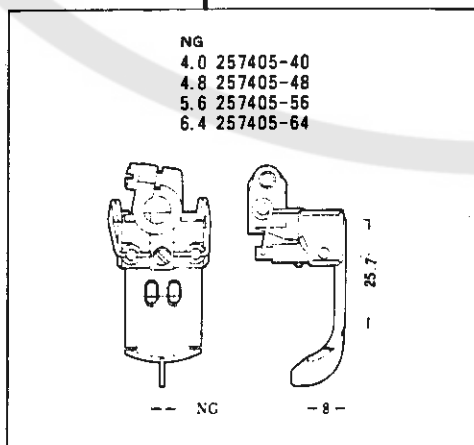
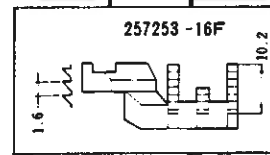
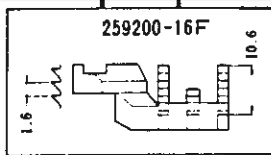
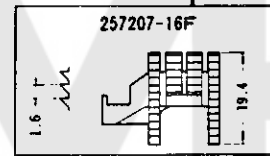
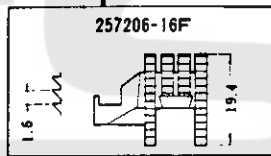
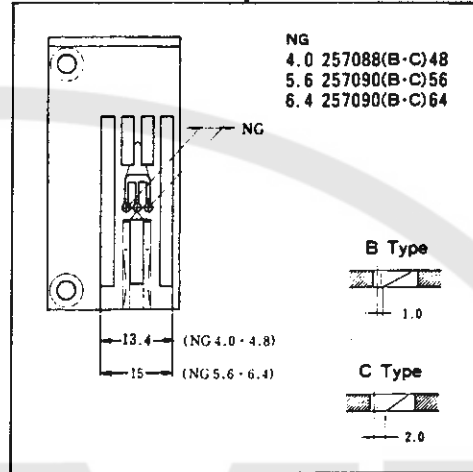
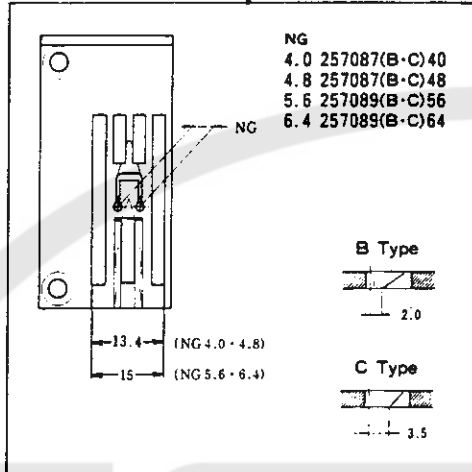

4542-03DB·DC

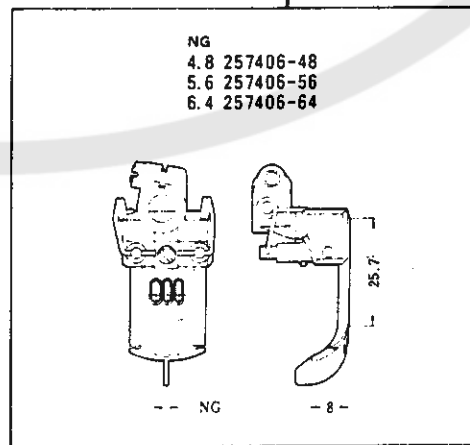

4542-03DB·DC

MACHINE	NEEDLE PLATE
4542-03DB	B TYPE
4542-03DC	C TYPE

COMMON PARTS

See page 70 for the looper and needle guards.

4562-03EB·EC

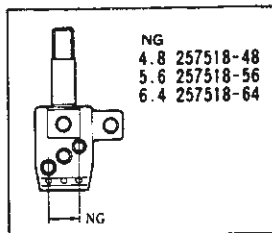
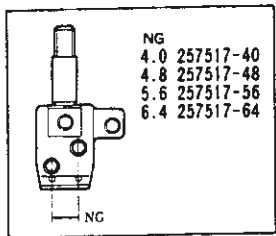

See pages 122,124

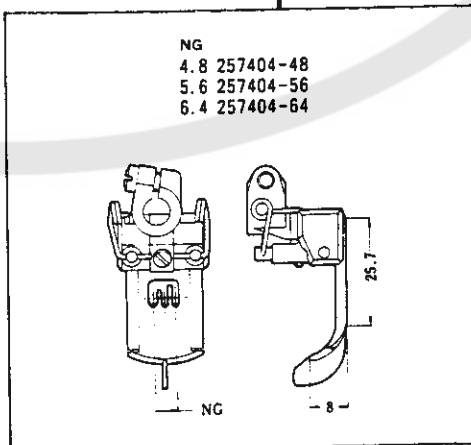
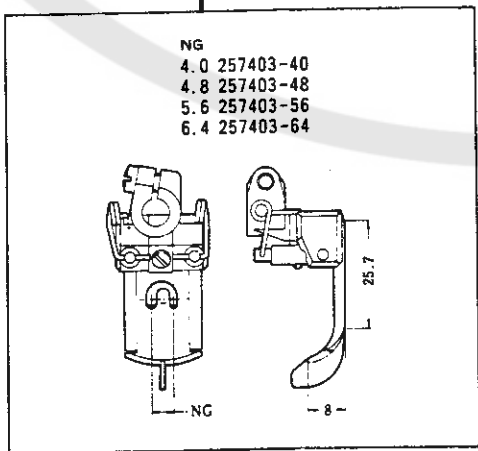
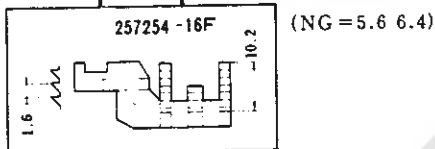
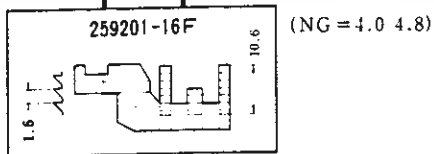
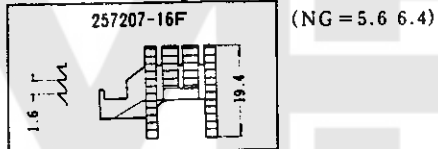
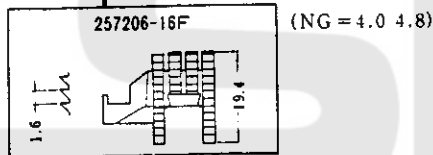
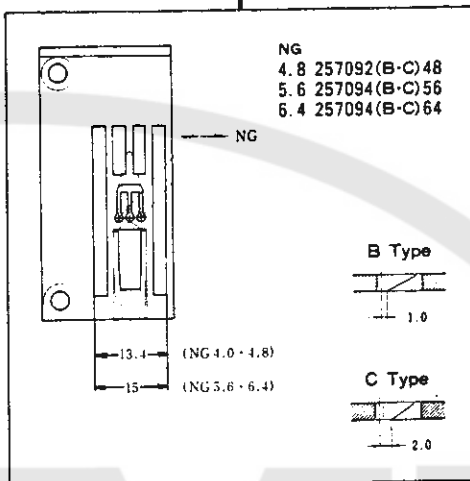
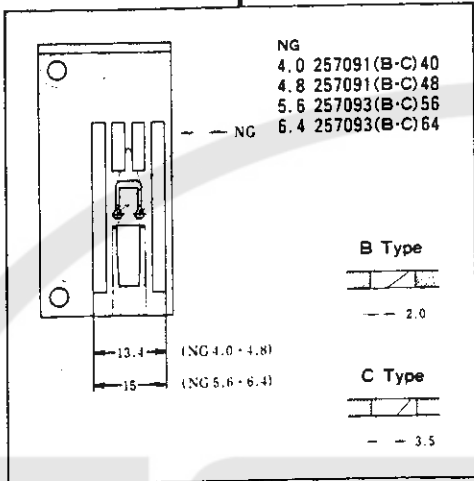

4562-03EB·EC

4562-03EB·EC

MACHINE	NEEDLE PLATE
4562-03EB	B TYPE
4562-03EC	C TYPE

COMMON PARTS

See page 70 for the looper and needle guards.

4542-03EB·EC

CONSTRUCTION CHART

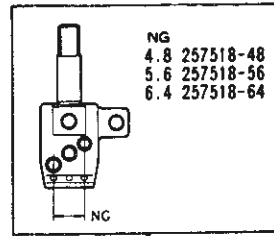
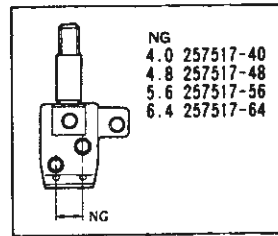

See pages 122,124

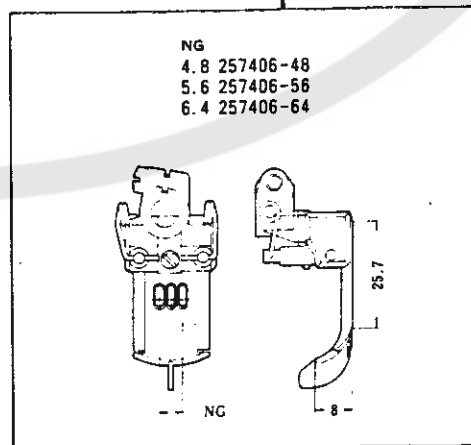
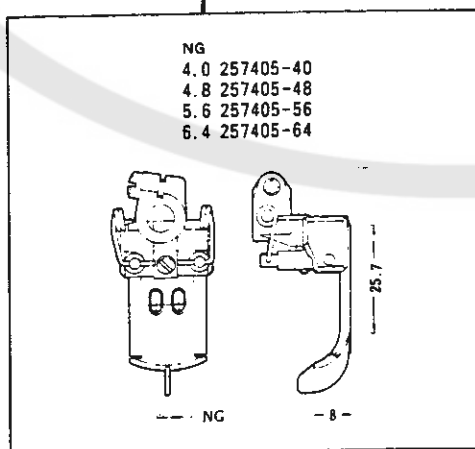
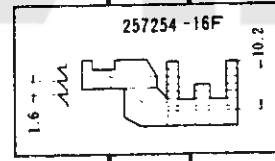
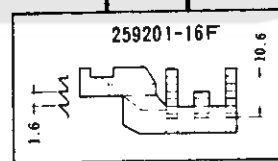
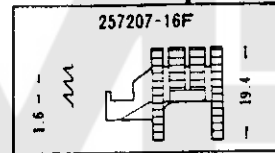
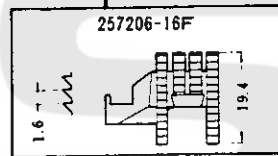
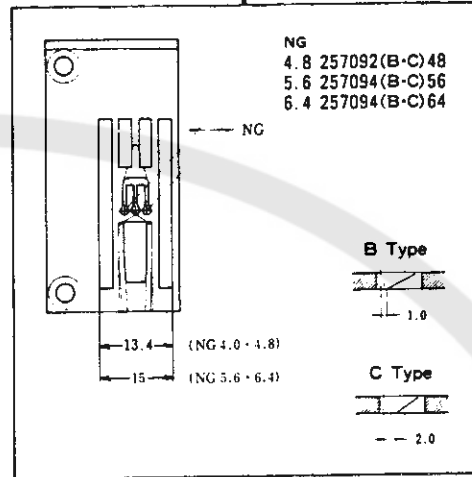
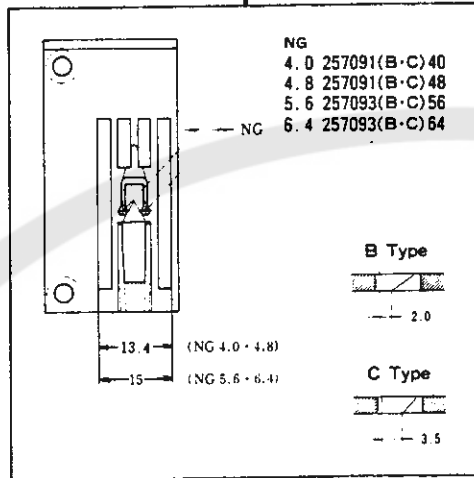

4542-03EB·EC

4542-03EB·EC

MACHINE	NEEDLE PLATE
4542-03EB	B TYPE
4542-03EC	C TYPE

COMMON PARTS

See page 70 for the looper and needle guards.

4562-05BA·BB 4562-05CA·CB

GAUGE PARTS CONSTRUCTION CHART

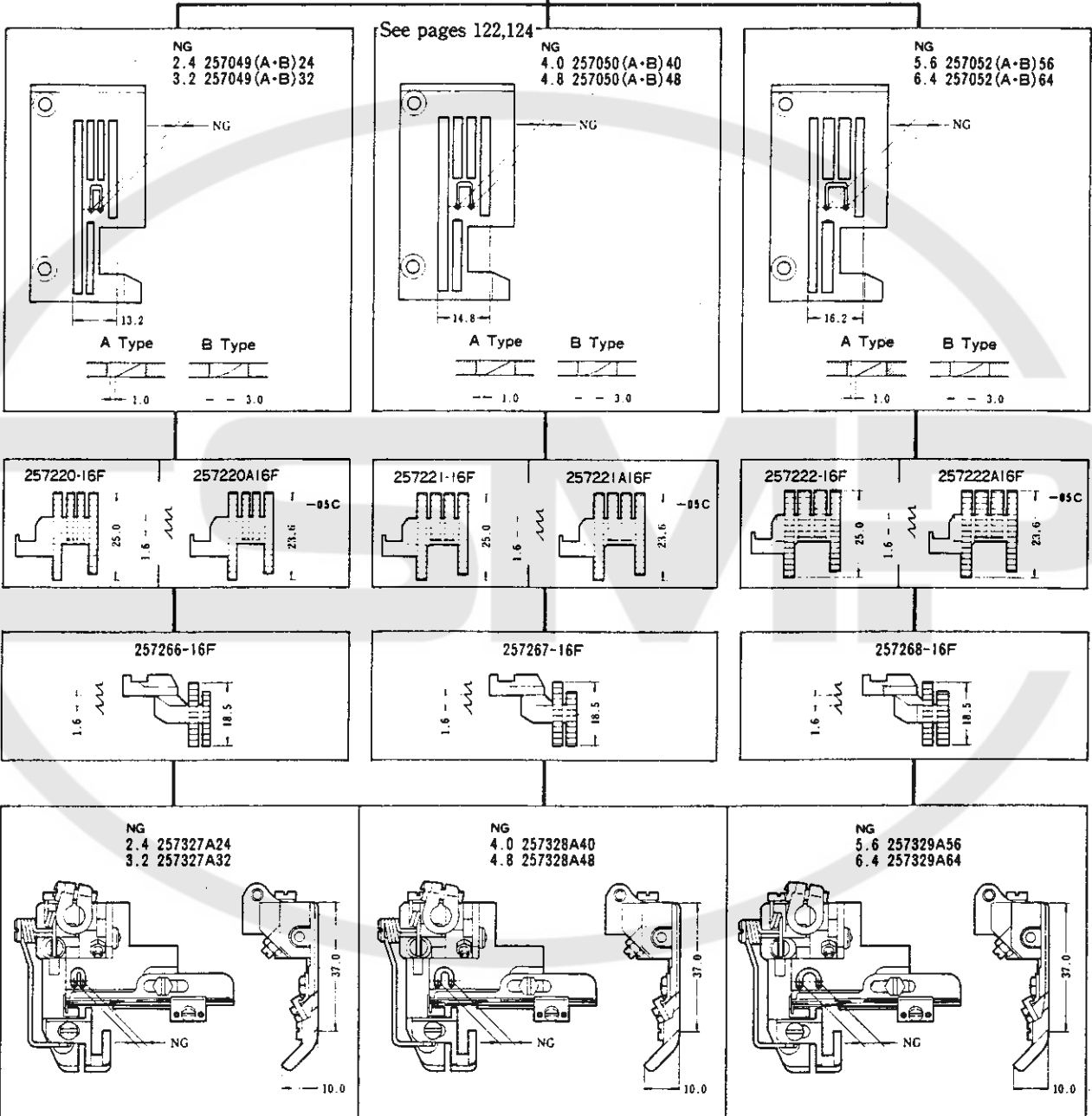
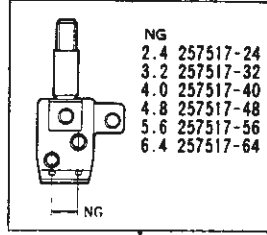

4562-05BA·BB
4562-05CA·CB ×224·232

4562-05BA·BB
4562-05CA·CB ×240·248

4562-05BA·BB
4562-05CA·CB ×256·264

MACHINE	NEEDLE PLATE
4562-05BA	A TYPE
4562-05BB	B TYPE

COMMON PARTS

See page 70 for the looper and needle guards.

It is the same with-05C type.

4562-05BA·BB
4562-05CA·CB

GUAGE PARTS
CONSTRUCTION CHART

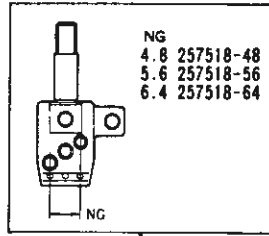

See pages 122,124

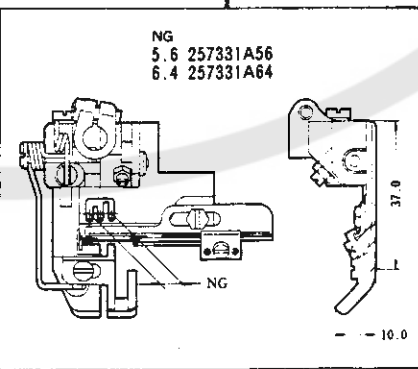
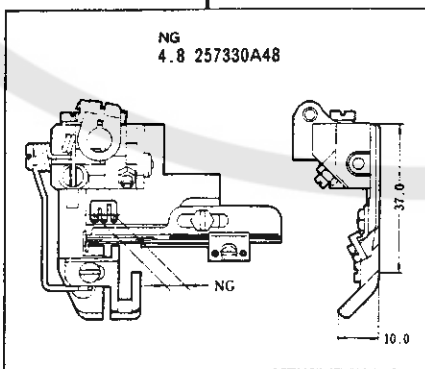
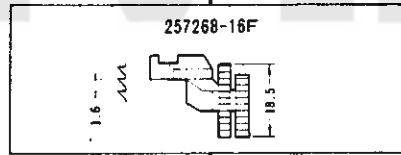
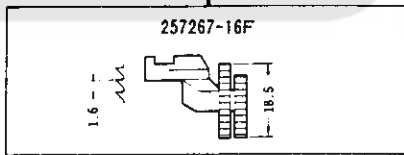
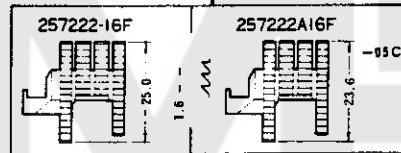
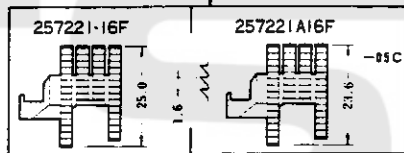
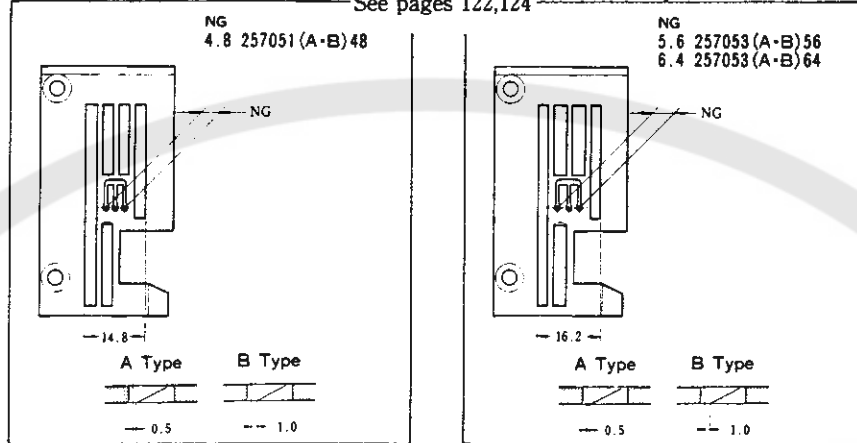

4562-05BA·BB
4562-05CA·CB X348

4562-05BA·BB
4562-05CA·CB X356-364

MACHINE	NEEDLE PLATE
4562-05BA	A TYPE
4562-05BB	B TYPE

COMMON PARTS

See page 70 for the looper and needle guards.

It is the same with -05C type.

4542-05BA·BB
4542-05CA·CB

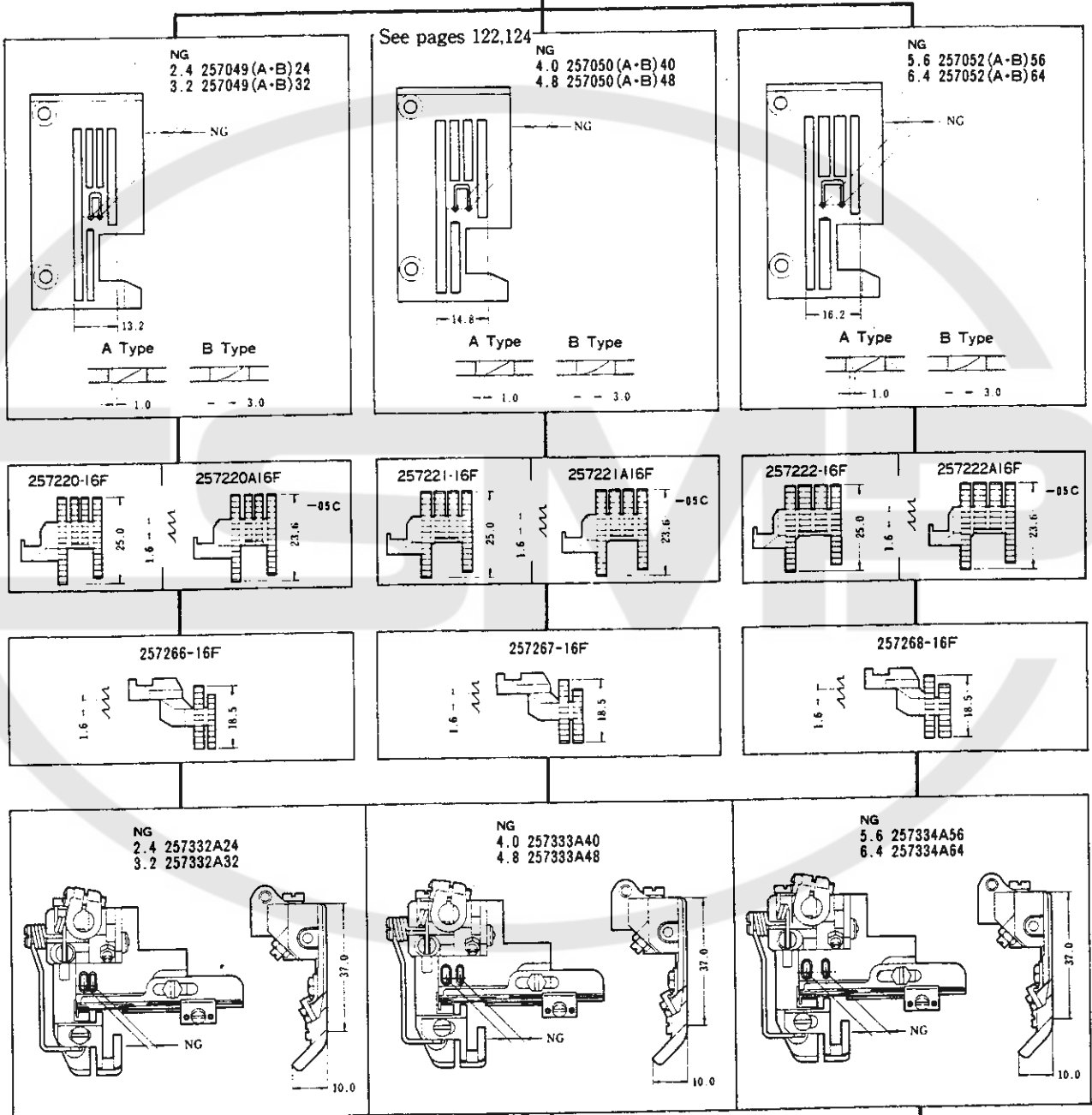
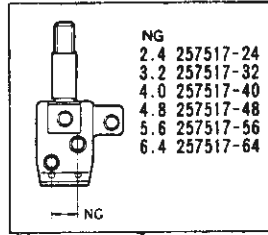

4542-05BA·BB
4542-05CA·CB ×224·232

4542-05BA·BB
4542-05CA·CB ×240·248

4542-05BA·BB
4542-05CA·CB ×256·264

MACHINE	NEEDLE PLATE
4542-05BA	A TYPE
4542-05BB	B TYPE

COMMON PARTS

See page 70 for the looper and needle guards.

It is the same with -05C type.

4542-05BA·BB
4542-05CA·CB

GAUGE PARTS
CONSTRUCTION CHART

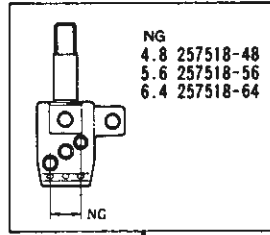

See pages 122,124

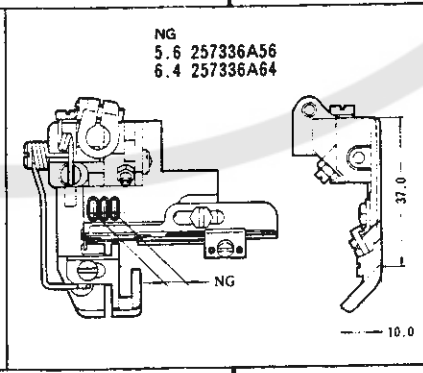
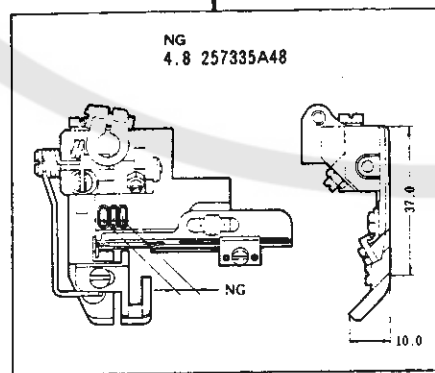
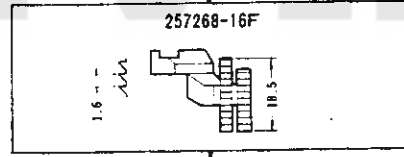
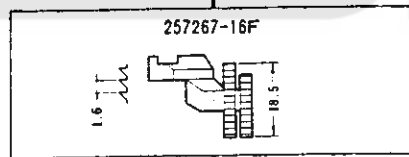
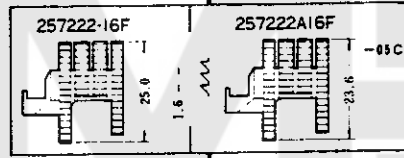
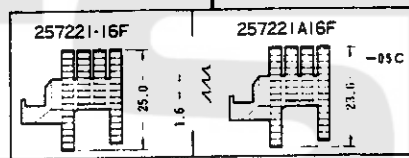
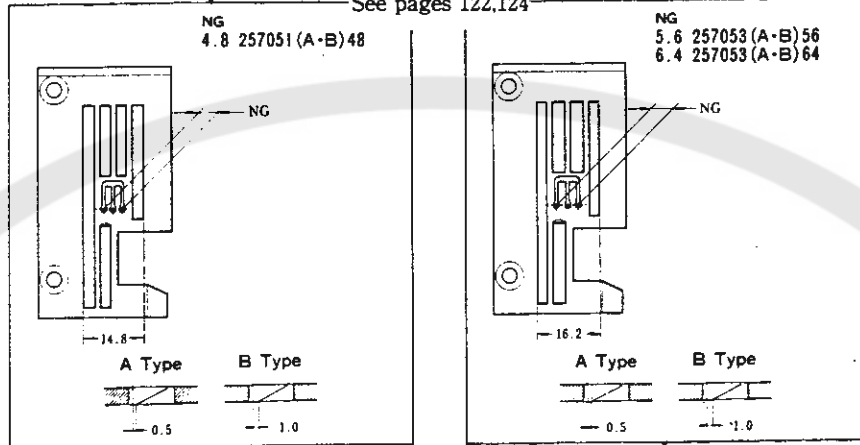

4542-05BA·BB
4542-05CA·CB ×348

4542-05BA·BB
4542-05CA·CB ×356·364

MACHINE	NEEDLE PLATE
4542-05BA	A TYPE
4542-05BB	B TYPE

COMMON PARTS

See page 70 for the looper and needle guards.

It is the same with -05C type.

4562-06-07BA, BB

GAUGE PARTS CONSTRUCTION CHART

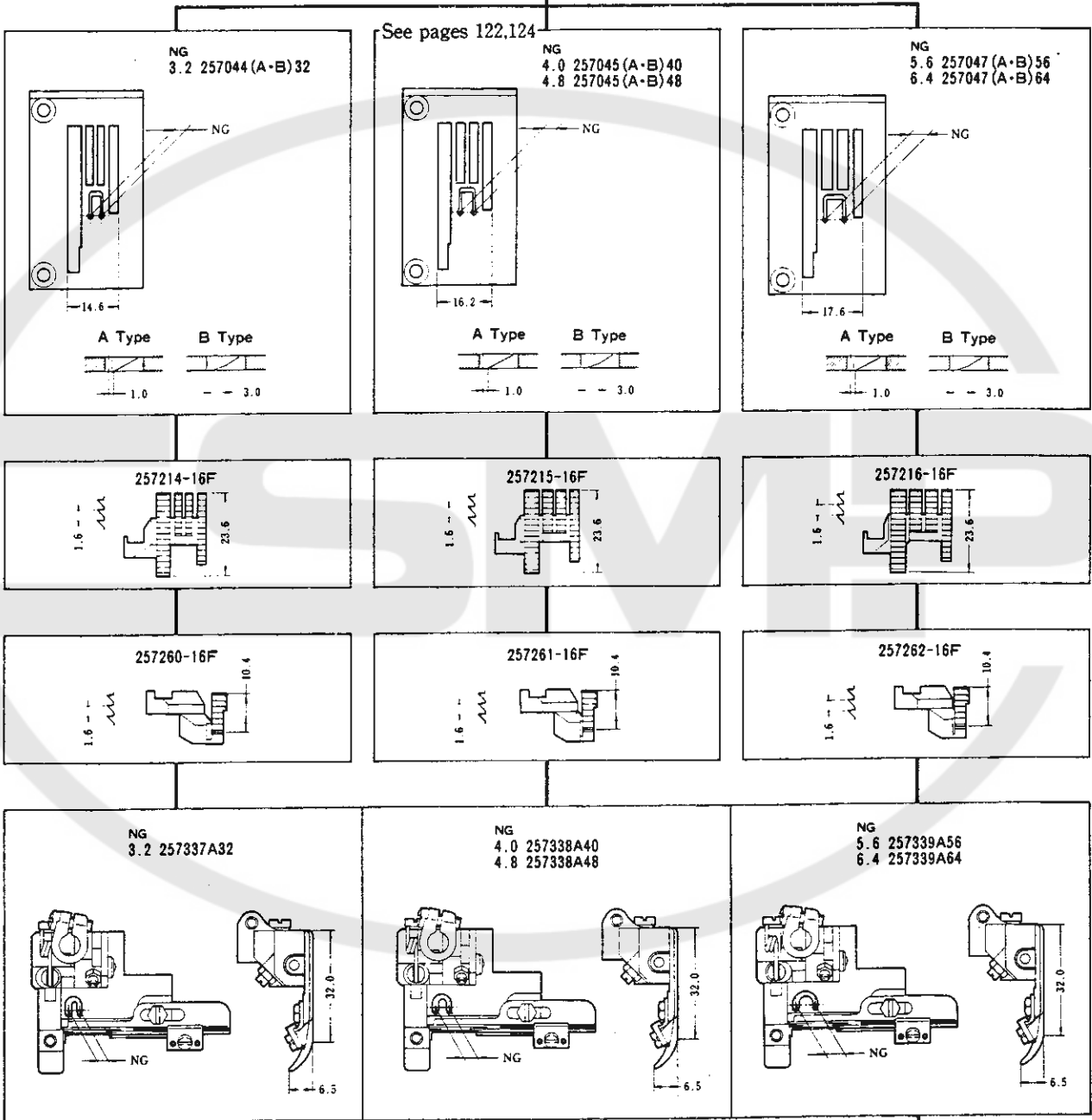
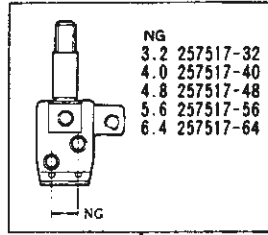

4562-06-07BA, BB × 232

4562-06-07BA, BB × 240-248

4562-06-07BA, BB × 256-264

MACHINE	NEEDLE PLATE
4562-06-07BA	A TYPE
4562-06-07BB	B TYPE

COMMON PARTS

See page 70 for the looper and needle guards.

4562-06-07BA, BB

GAUGE PARTS CONSTRUCTION CHART

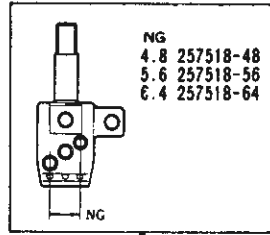

See pages 122,124

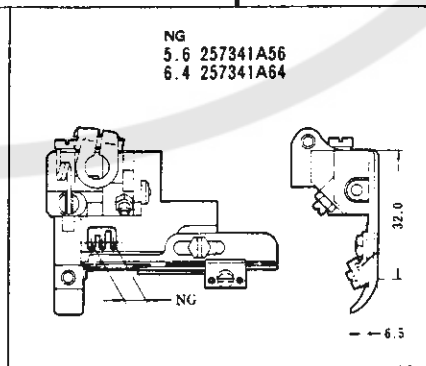
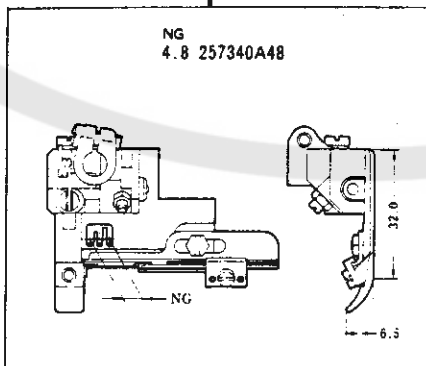
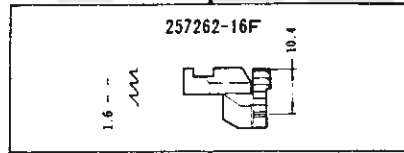
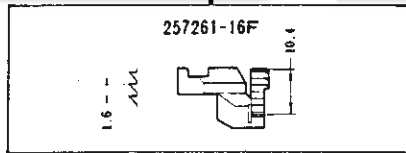
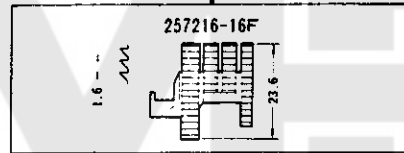
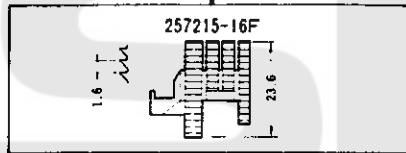
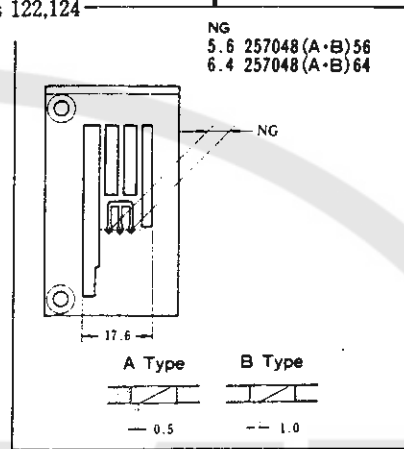
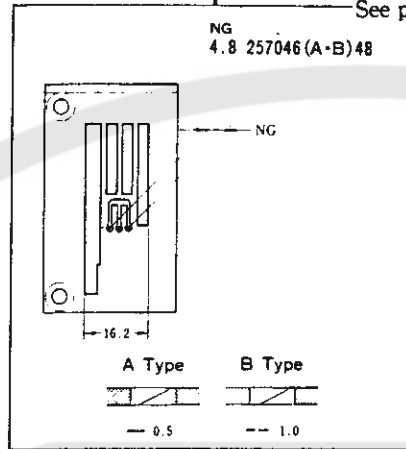

4562-06-07BA, BB X 348

4562-06-07BA, BB X 356-364

MACHINE	NEEDLE PLATE
4562-06-07BA	A TYPE
W562-06-07BB	B TYPE

COMMON PARTS

See page 70 for the looper and needle guards.

4542-06·07BA, BB

GAUGE PARTS CONSTRUCTION CHART

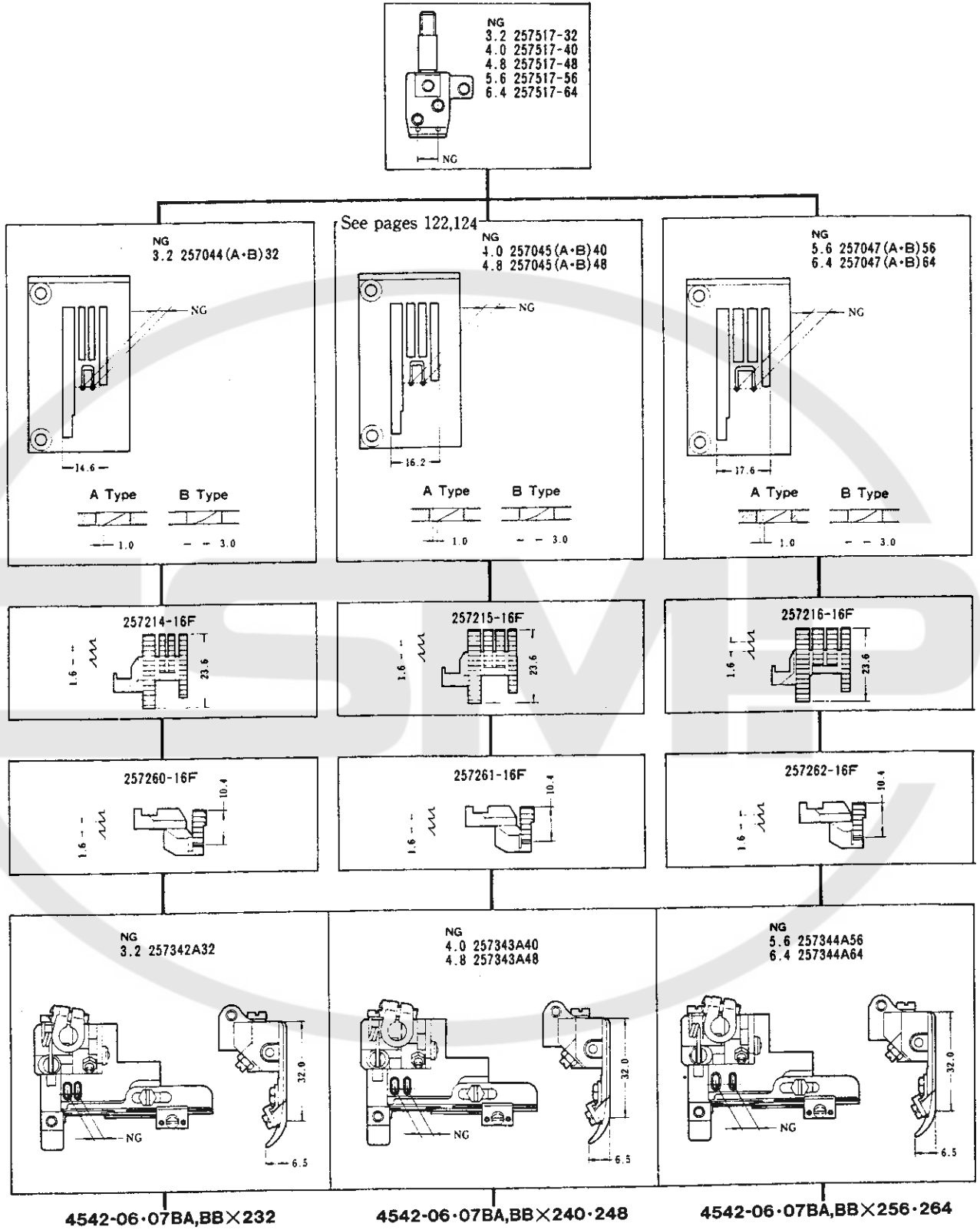

MACHINE	NEEDLE PLATE
4542-06·07BA	A TYPE
4542-06·07BB	B TYPE

COMMON PARTS

See page 70 for the looper and needle guards.

4542-06·07BA, BB

GAUGE PARTS CONSTRUCTION CHART

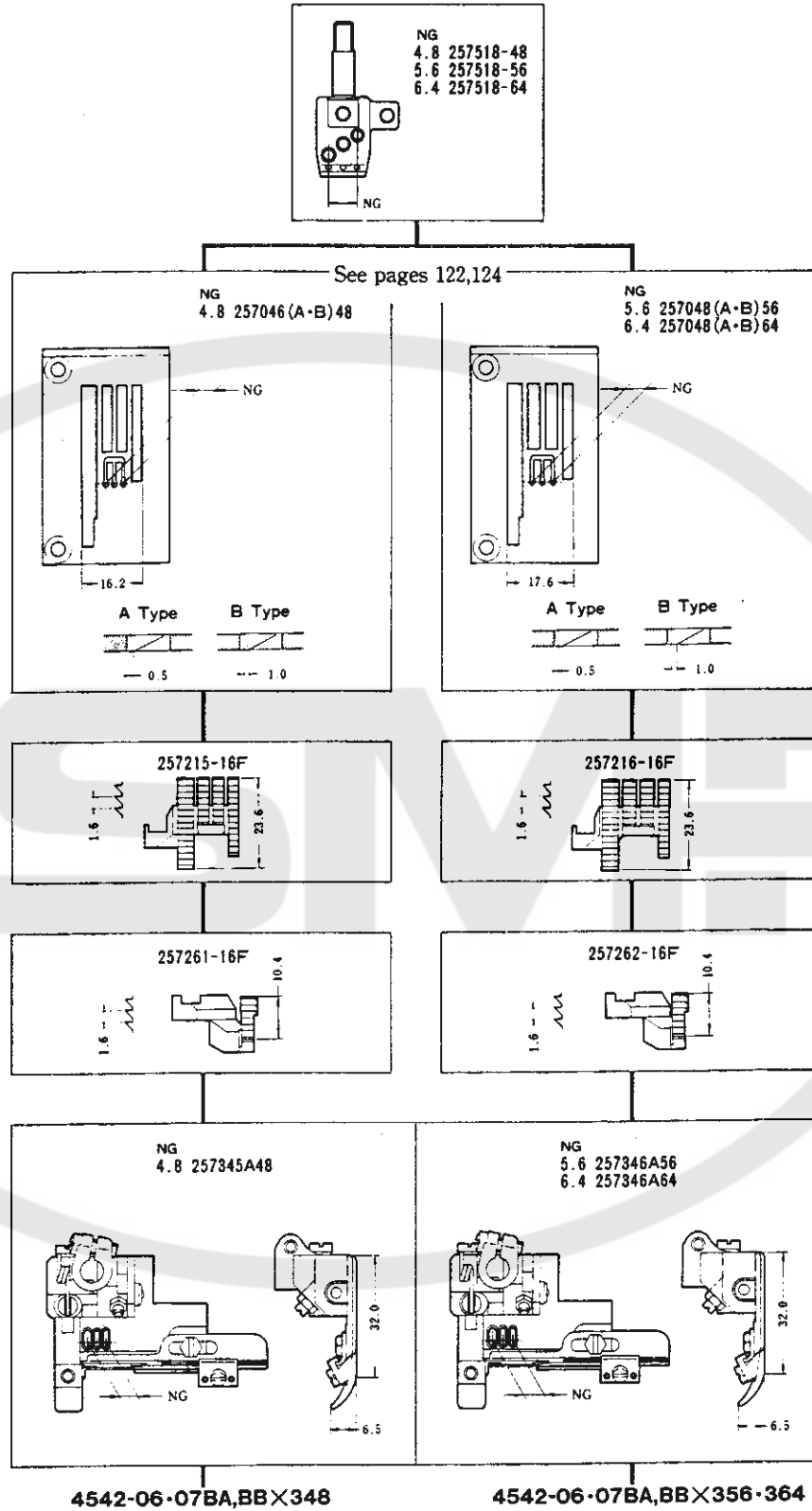

MACHINE	NEEDLE PLATE
4542-06-07BA	A TYPE
4542-06-07BB	B TYPE

COMMON PARTS

See page 70 for the looper and needle guards.

4562-08AB·AC

GAUGE PARTS CONSTRUCTION CHART

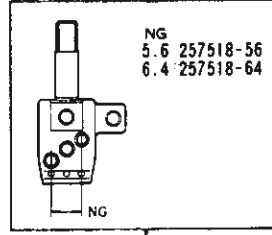
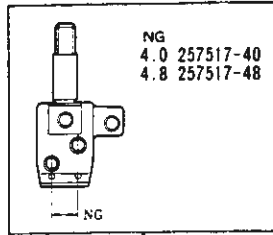

See pages 122,124

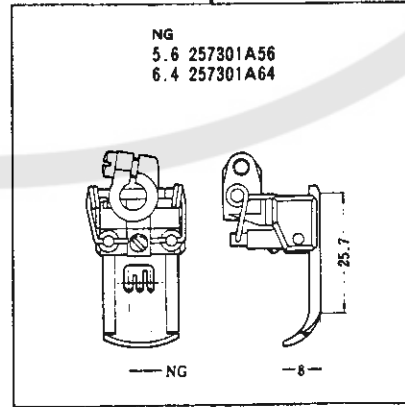
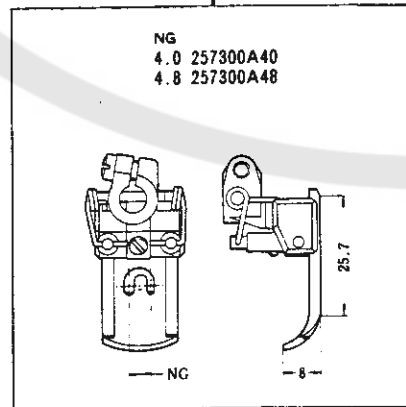
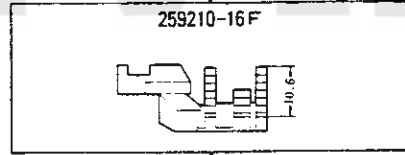
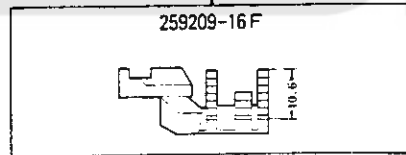
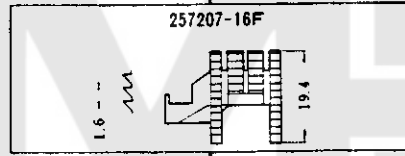
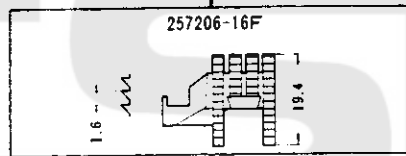
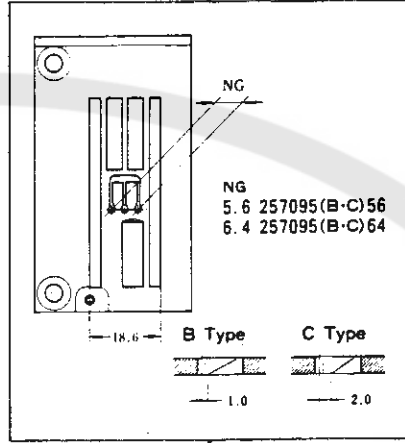
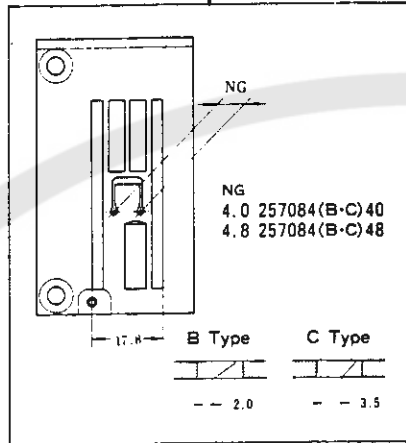

4562-08AB·AC

4562-08AB·AC

MACHINE	NEEDLE PLATE
4562-08AB	B TYPE
4562-08AC	C TYPE

COMMON PARTS

See page 70 for the looper and needle guards.

4542-08AB·AC

GAUGE PARTS CONSTRUCTION CHART

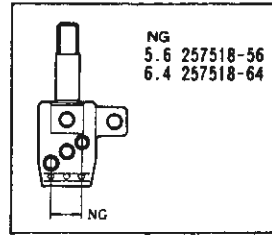
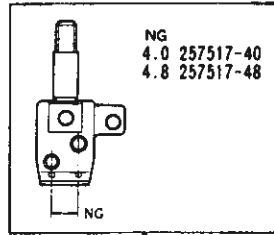

See pages 122,124

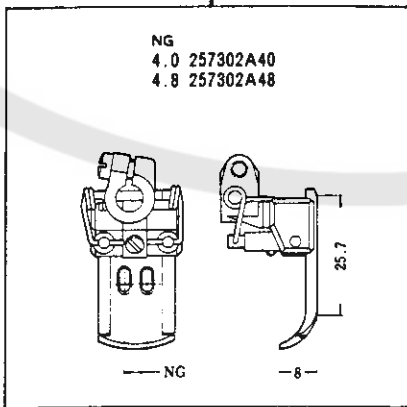
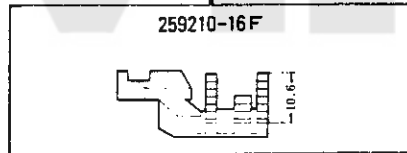
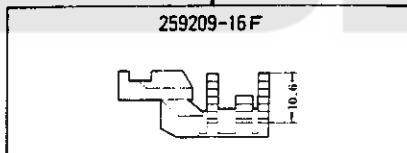
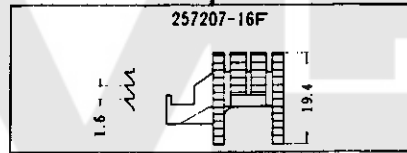
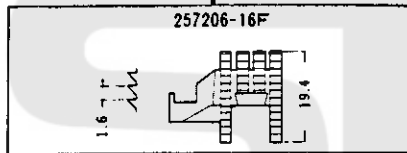
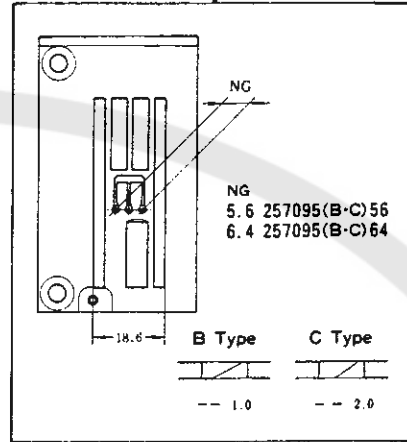
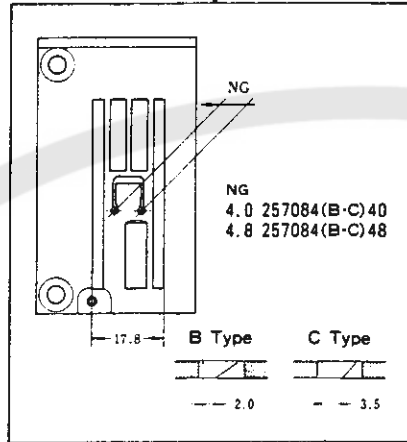

4542-08AB·AC

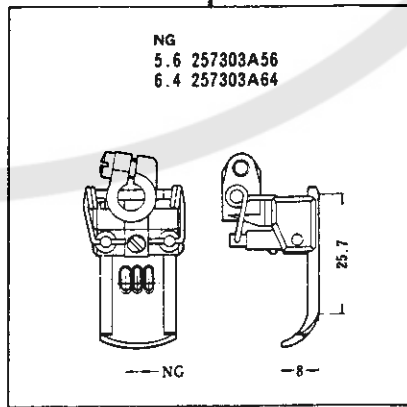

4542-08AB·AC

MACHINE	NEEDLE PLATE
4542-08AB	B TYPE
4542-08AC	C TYPE

COMMON PARTS

See page 70 for the looper and needle guards.

4562-21BA·BB

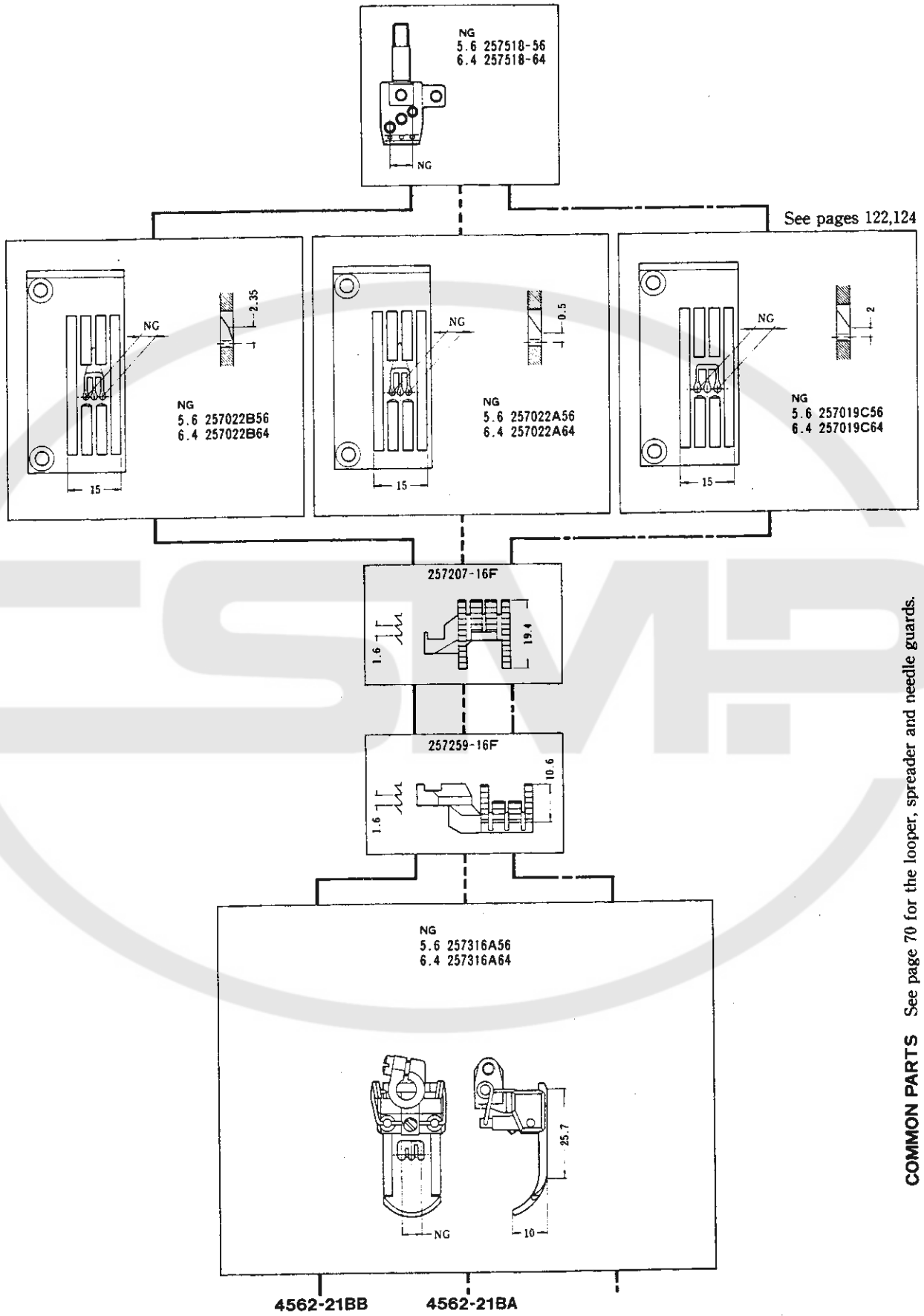







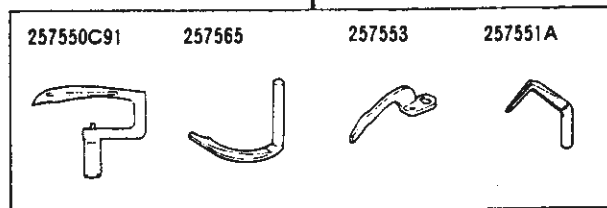
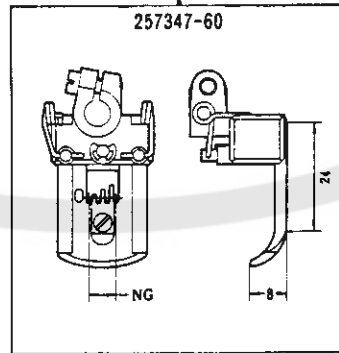
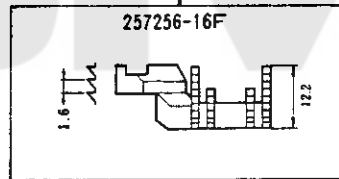
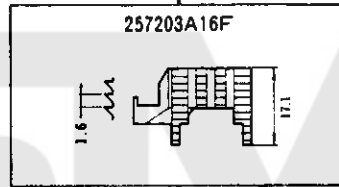
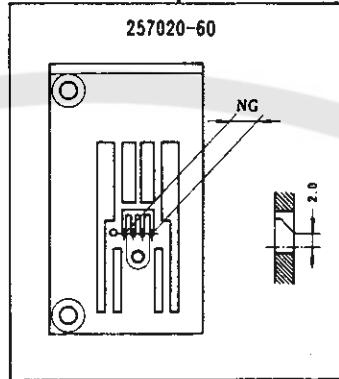
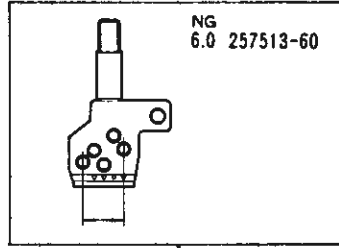



COMMON PARTS See page 70 for the looper, spreader and needle guards.

4562-01DB
4561-01DB

GAUGE PARTS
CONSTRUCTION CHART



											
MACHINE	GAUGE	NEEDLE HOLDER	NEEDLE PLATE	MAIN FEED DOG	DIFF. FEED DOG	PRESSER FOOT ASS.	LOOPER	NDL GUARD (FRONT)	NDL GUARD (REAR)	NEEDLE SYSTEM	NEEDLE SIZE
4562-01CA	224	257517-24	257015A24	257206-16F	257258-16F	257300A24	257550-91	257553	257551B	UY128GAS	#11
	232	" 32	" 32	"	"	" 32	"	"	"	"	"
	240	" 40	" 40	"	"	" 40	"	"	"	"	"
	248	" 48	" 48	"	"	" 48	"	"	"	"	"
	256	" 56	257017A56	257207-16F	257259-16F	" 56	"	"	"	"	"
	264	" 64	" 64	"	"	" 64	"	"	"	"	"
	348	257518-48	257016A48	257206-16F	257258-16F	257301A48	"	"	"	"	#11
	356	" 56	257018A56	257207-16F	257259-16F	" 56	"	"	"	"	"
364	" 64	" 64	"	"	" 64	"	"	"	"	"	
4562-01CB	224	257517-24	257015B24	257206-16F	257258-16F	257300A24	257550-91	257553	257551B	UY128GAS	#11
	232	" 32	" 32	"	"	" 32	"	"	"	"	"
	240	" 40	" 40	"	"	" 40	"	"	"	"	"
	248	" 48	" 48	"	"	" 48	"	"	"	"	"
	256	" 56	257017B56	257207-16F	257259-16F	" 56	"	"	"	"	"
	264	" 64	" 64	"	"	" 64	"	"	"	"	"
	348	257518-48	257016B48	257206-16F	257258-16F	257301A48	"	"	"	"	#11
	356	" 56	257018B56	257207-16F	257259-16F	" 56	"	"	"	"	"
364	" 64	" 64	"	"	" 64	"	"	"	"	"	
4562-01CC	224	257517-24	257015C24	257206-16F	257258-16F	257300A24	257550-91	257553	257551B	UY128GAS	#11
	232	" 32	" 32	"	"	" 32	"	"	"	"	"
	240	" 40	" 40	"	"	" 40	"	"	"	"	"
	248	" 48	" 48	"	"	" 48	"	"	"	"	"
	256	" 56	257017C56	257207-16F	257259-16F	" 56	"	"	"	"	"
	264	" 64	" 64	"	"	" 64	"	"	"	"	"
	348	257518-48	257016C48	257206-16F	257258-16F	257301A48	"	"	"	"	#11
	356	" 56	257018C56	257207-16F	257259-16F	" 56	"	"	"	"	"
364	" 64	" 64	"	"	" 64	"	"	"	"	"	

※
 Looper gauge = 348
 257550-91
 ↓
 257550E91
 Starting in Sept, 1990

MACHINE	GAUGE	NEEDLE HOLDER	NEEDLE PLATE	MAIN FEED DOG	DIFF. FEED DOG	PRESSER FOOT ASS.	LOOPER	NDL GUARD (FRONT)	NDL GUARD (REAR)	NEEDLE SYSTEM	NEEDLE SIZE
4542-01CA	224	257517-24	257015A24	257206-16F	257258-16F	257302A24	257550-91	257553	257551B	UY128GAS	#9
	232	" 32	" 32	"	"	" 32	"	"	"	"	"
	240	" 40	" 40	"	"	" 40	"	"	"	"	"
	248	" 48	" 48	"	"	" 48	"	"	"	"	"
	256	" 56	257017A56	257207-16F	257259-16F	" 56	"	"	"	"	"
	264	" 64	" 64	"	"	" 64	"	"	"	"	"
	348	257518-48	257016A48	257206-16F	257258-16F	257303A48	"	"	"	"	#10
	356	" 56	257018A56	257207-16F	257259-16F	" 56	"	"	"	"	"
364	" 64	" 64	"	"	" 64	"	"	"	"	"	
4542-01CB	224	257517-24	257015B24	257206-16F	257258-16F	257302A24	257550-91	257553	257551B	UY128GAS	#9
	232	" 32	" 32	"	"	" 32	"	"	"	"	"
	240	" 40	" 40	"	"	" 40	"	"	"	"	"
	248	" 48	" 48	"	"	" 48	"	"	"	"	"
	256	" 56	257017B56	257207-16F	257259-16F	" 56	"	"	"	"	"
	264	" 64	" 64	"	"	" 64	"	"	"	"	"
	348	257518-48	257016B48	257206-16F	257258-16F	257303A48	"	"	"	"	#11
	356	" 56	257018B56	257207-16F	257259-16F	" 56	"	"	"	"	"
364	" 64	" 64	"	"	" 64	"	"	"	"	"	
4542-01CC	224	257517-24	257015C24	257206-16F	257258-16F	257302A24	257550-91	257553	257551B	UY128GAS	#11
	232	" 32	" 32	"	"	" 32	"	"	"	"	"
	240	" 40	" 40	"	"	" 40	"	"	"	"	"
	248	" 48	" 48	"	"	" 48	"	"	"	"	"
	256	" 56	257017C56	257207-16F	257259-16F	" 56	"	"	"	"	"
	264	" 64	" 64	"	"	" 64	"	"	"	"	"
	348	257518-48	257016C48	257206-16F	257258-16F	257303A48	"	"	"	"	#11
	356	" 56	257018C56	257207-16F	257259-16F	" 56	"	"	"	"	"
364	" 64	" 64	"	"	" 64	"	"	"	"	"	

※
 Looper gauge=348
 257550-91
 ↓
 257550E91
 Starting in Sept, 1990

4500-02 GAUGE PARTS LIST (3)

MACHINE	GAUGE	NEEDLE HOLDER	NEEDLE PLATE	MAIN FEED DOG	DIFF. FEED DOG	PRESSER FOOT ASS.	LOOPER	NDL GUARD (FRONT)	NDL GUARD (REAR)	NEEDLE SIZE
4562-02RA	2 2.4	257517-24	257029A24	257214-16F	257260-16F	257317A24	257550-91	257553	257551B	UY128GAS #11
	2 3.2	" 32	" A32	" "	" "	" A32	" "	" "	" "	" "
	2 4.0	" 40	257030A40	257215-16F	257261-16F	257318A40	" "	" "	" "	" "
	2 4.8	" 48	" A48	" "	" "	" A48	" "	" "	" "	" "
	2 5.6	" 56	257032A56	257216-16F	257262-16F	257319A56	" "	" "	" "	" "
	2 6.4	" 64	" A64	" "	" "	" A64	" "	" "	" "	" "
	3 4.8	257518-48	257031A48	257215-16F	257261-16F	257320A48	" "	" "	" "	#11
	3 5.6	" 56	257033A56	257216-16F	257262-16F	257321A56	" "	" "	" "	" "
	3 6.4	" 64	" A64	" "	" "	" A64	" "	" "	" "	" "
4562-02BR	2 2.4	257517-24	257029B24	257214-16F	257260-16F	257317A24	257550-91	257553	257551B	UY128GAS #11
	2 3.2	" 32	" B32	" "	" "	" A32	" "	" "	" "	" "
	2 4.0	" 40	257030B40	257215-16F	257261-16F	257318A40	" "	" "	" "	" "
	2 4.8	" 48	" B48	" "	" "	" A48	" "	" "	" "	" "
	2 5.6	" 56	257032B56	257216-16F	257262-16F	257319A56	" "	" "	" "	" "
	2 6.4	" 64	" B64	" "	" "	" A64	" "	" "	" "	" "
	3 4.8	257518-48	257031B48	257215-16F	257261-16F	257320A48	" "	" "	" "	#11
	3 5.6	" 56	257033B56	257216-16F	257262-16F	257321A56	" "	" "	" "	" "
	3 6.4	" 64	" B64	" "	" "	" A64	" "	" "	" "	" "
4562-02BC	2 2.4	257517-24	257029C24	257214-16F	257260-16F	257317A24	257550-91	257553	257551B	UY128GAS #11
	2 3.2	" 32	" C32	" "	" "	" A32	" "	" "	" "	" "
	2 4.0	" 40	257030C40	257215-16F	257261-16F	257318A40	" "	" "	" "	" "
	2 4.8	" 48	" C48	" "	" "	" A48	" "	" "	" "	" "
	2 5.6	" 56	257032C56	257216-16F	257262-16F	257319A56	" "	" "	" "	" "
	2 6.4	" 64	" C64	" "	" "	" A64	" "	" "	" "	" "
	3 4.8	257518-48	257031C48	257215-16F	257261-16F	257320A48	" "	" "	" "	#11
	3 5.6	" 56	257033C56	257216-16F	257262-16F	257321A56	" "	" "	" "	" "
	3 6.4	" 64	" C64	" "	" "	" A64	" "	" "	" "	" "
4542-02BA	2 2.4	257517-24	257029A24	257214-16F	257260-16F	257322A24	257550-91	257553	257551B	UY128GAS #11
	2 3.2	" 32	" A32	" "	" "	" A32	" "	" "	" "	" "
	2 4.0	" 40	257030A40	257215-16F	257261-16F	257323A40	" "	" "	" "	" "
	2 4.8	" 48	" A48	" "	" "	" A48	" "	" "	" "	" "
	2 5.6	" 56	257032A56	257216-16F	257262-16F	257324A56	" "	" "	" "	" "
	2 6.4	" 64	" A64	" "	" "	" A64	" "	" "	" "	" "
	3 4.8	257518-48	257031A48	257215-16F	257261-16F	257325A48	" "	" "	" "	#11
	3 5.6	" 56	257033A56	257216-16F	257262-16F	257326A56	" "	" "	" "	" "
	3 6.4	" 64	" A64	" "	" "	" A64	" "	" "	" "	" "
4542-02BR	2 2.4	257517-24	257029B24	257214-16F	257260-16F	257322A24	257550-91	257553	257551B	UY128GAS #11
	2 3.2	" 32	" B32	" "	" "	" A32	" "	" "	" "	" "
	2 4.0	" 40	257030B40	257215-16F	257261-16F	257323A40	" "	" "	" "	" "
	2 4.8	" 48	" B48	" "	" "	" A48	" "	" "	" "	" "
	2 5.6	" 56	257032B56	257216-16F	257262-16F	257324A56	" "	" "	" "	" "
	2 6.4	" 64	" B64	" "	" "	" A64	" "	" "	" "	" "
	3 4.8	257518-48	257031B48	257215-16F	257261-16F	257325A48	" "	" "	" "	#11
	3 5.6	" 56	257033B56	257216-16F	257262-16F	257326A56	" "	" "	" "	" "
	3 6.4	" 64	" B64	" "	" "	" A64	" "	" "	" "	" "
4542-02BC	2 2.4	257517-24	257029C24	257214-16F	257260-16F	257322A24	257550-91	257553	257551B	UY128GAS #11
	2 3.2	" 32	" C32	" "	" "	" A32	" "	" "	" "	" "
	2 4.0	" 40	257030C40	257215-16F	257261-16F	257323A40	" "	" "	" "	" "
	2 4.8	" 48	" C48	" "	" "	" A48	" "	" "	" "	" "
	2 5.6	" 56	257032C56	257216-16F	257262-16F	257324A56	" "	" "	" "	" "
	2 6.4	" 64	" C64	" "	" "	" A64	" "	" "	" "	" "
	3 4.8	257518-48	257031C48	257215-16F	257261-16F	257325A48	" "	" "	" "	#11
	3 5.6	" 56	257033C56	257216-16F	257262-16F	257326A56	" "	" "	" "	" "
	3 6.4	" 64	" C64	" "	" "	" A64	" "	" "	" "	" "











※
 Looper gauge = 348
 257550-91
 ↓
 257550E.91
 Starting in Sept, 1990



MACHINE	GAUGE	NEEDLE HOLDER	NEEDLE PLATE	MAIN FEED DOG	DIFF. FEED DOG	PRESSER FOOT ASS.	LOOPER	NDL GUARD (FRONT)	NDL GUARD (REAR)	NEEDLE SYSTEM	NEEDLE SIZE
4562-03AB	240	257517-40	257005B40	257200-16F	257253-16F	257312-40	257550-91	257553	257551B	UY128GAS	#11
	248	" 48	" 48	"	"	" 48	"	"	"	"	"
	256	" 56	" 56	"	"	" 56	"	"	"	"	"
	264	" 64	" 64	"	"	" 64	"	"	"	"	"
	348	257518-48	257006B48	"	"	257313-48	"	"	"	"	#11
	356	" 56	" 56	"	"	" 56	"	"	"	"	"
364	" 64	" 64	"	"	" 64	"	"	"	"	"	
4562-03AC	240	257517-40	257005C40	257200-16F	257253-16F	257312-40	257550-91	257553	257551B	UY128GAS	#11
	248	" 48	" 48	"	"	" 48	"	"	"	"	"
	256	" 56	" 56	"	"	" 56	"	"	"	"	"
	264	" 64	" 64	"	"	" 64	"	"	"	"	"
	348	257518-48	257006C48	"	"	257313-48	"	"	"	"	#11
	356	" 56	" 56	"	"	" 56	"	"	"	"	"
364	" 64	" 64	"	"	" 64	"	"	"	"	"	
4562-03BB	240	257517-40	257007B40	257200-16F	257254-16F	257312-40	257550-91	257553	257551B	UY128GAS	#11
	248	" 48	" 48	"	"	" 48	"	"	"	"	"
	256	" 56	" 56	"	"	" 56	"	"	"	"	"
	264	" 64	" 64	"	"	" 64	"	"	"	"	"
	348	257518-48	257008B48	"	"	257313-48	"	"	"	"	#11
	356	" 56	" 56	"	"	" 56	"	"	"	"	"
364	" 64	" 64	"	"	" 64	"	"	"	"	"	
4562-03BC	240	257517-40	257007C40	257200-16F	257254-16F	257312-40	257550-91	257553	257551B	UY128GAS	#11
	248	" 48	" 48	"	"	" 48	"	"	"	"	"
	256	" 56	" 56	"	"	" 56	"	"	"	"	"
	264	" 64	" 64	"	"	" 64	"	"	"	"	"
	348	257518-48	257008C48	"	"	257313-48	"	"	"	"	#11
	356	" 56	" 56	"	"	" 56	"	"	"	"	"
364	" 64	" 64	"	"	" 64	"	"	"	"	"	
4542-03AB	240	257517-40	257005B40	257200-16F	257253-16F	257314-40	257550-91	257553	257551B	UY128GAS	#11
	248	" 48	" 48	"	"	" 48	"	"	"	"	"
	256	" 56	" 56	"	"	" 56	"	"	"	"	"
	264	" 64	" 64	"	"	" 64	"	"	"	"	"
	348	257518-48	257006B48	"	"	257315-48	"	"	"	"	#11
	356	" 56	" 56	"	"	" 56	"	"	"	"	"
364	" 64	" 64	"	"	" 64	"	"	"	"	"	
4542-03AC	240	257517-40	257005C40	257200-16F	257253-16F	257314-40	257550-91	257553	257551B	UY128GAS	#11
	248	" 48	" 48	"	"	" 48	"	"	"	"	"
	256	" 56	" 56	"	"	" 56	"	"	"	"	"
	264	" 64	" 64	"	"	" 64	"	"	"	"	"
	348	257518-48	257006C48	"	"	257315-48	"	"	"	"	#11
	356	" 56	" 56	"	"	" 56	"	"	"	"	"
364	" 64	" 64	"	"	" 64	"	"	"	"	"	
4542-03BB	240	257517-40	257007B40	257200-16F	257254-16F	257314-40	257550-91	257553	257551B	UY128GAS	#11
	248	" 48	" 48	"	"	" 48	"	"	"	"	"
	256	" 56	" 56	"	"	" 56	"	"	"	"	"
	264	" 64	" 64	"	"	" 64	"	"	"	"	"
	348	257518-48	257008B48	"	"	257315-48	"	"	"	"	#11
	356	" 56	" 56	"	"	" 56	"	"	"	"	"
364	" 64	" 64	"	"	" 64	"	"	"	"	"	
4542-03BC	240	257517-40	257007C40	257200-16F	257254-16F	257314-40	257550-91	257553	257551B	UY128GAS	#11
	248	" 48	" 48	"	"	" 48	"	"	"	"	"
	256	" 56	" 56	"	"	" 56	"	"	"	"	"
	264	" 64	" 64	"	"	" 64	"	"	"	"	"
	348	257518-48	257008C48	"	"	257315-48	"	"	"	"	#11
	356	" 56	" 56	"	"	" 56	"	"	"	"	"
364	" 64	" 64	"	"	" 64	"	"	"	"	"	

4500-03 GAUGE PARTS LIST (4) [OLD]

4500-03 GAUGE PARTS LIST (5)

											
MACHINE	GAUGE	NEEDLE HOLDER	NEEDLE PLATE	MAIN FEED DOG	DIFF. FEED DOG	PRESSER FOOT ASS.	LOOPER	NDL GUARD (FRONT)	NDL GUARD (REAR)	NEEDLE SIZE	
4562-03DB	2 4.0	257517-40	257087840 B48	257206-16F	259200-16F	257403-40 -48	257550-91	257553	257551B	UY128GAS #11	
	2 4.8	-	B48	-	-	-48	-	-	-	-	
	2 5.6	-	257089856 B64	257207-16F	257253-16F	-56	-	-	-	-	
	2 6.4	-	B64	-	-	-64	-	-	-	-	
	3 4.8	257518-48	257088848	257206-16F	259200-16F	257404-48	-	-	-	#10	
	3 5.6	-	257090856 B64	257207-16F	257253-16F	-56	-	-	-	-	
3 6.4	-	B64	-	-	-64	-	-	-	-	-	
4562-03DC	2 4.0	257517-40	257087C40 C48	257206-16F	259200-16F	257403-40 -48	257550-91	257553	257551B	UY128GAS #11	
	2 4.8	-	C48	-	-	-48	-	-	-	-	
	2 5.6	-	257089C56 C64	257207-16F	257253-16F	-56	-	-	-	-	
	2 6.4	-	C64	-	-	-64	-	-	-	-	
	3 4.8	257518-48	257088C48	257206-16F	259200-16F	257404-48	-	-	-	#11	
	3 5.6	-	257090C56 C64	257207-16F	257253-16F	-56	-	-	-	-	
3 6.4	-	C64	-	-	-64	-	-	-	-	-	
4562-03EB	2 4.0	257517-40	257091840 B48	257206-16F	259201-16F	257403-40 -48	257550-91	257553	257551B	UY128GAS #11	
	2 4.8	-	B48	-	-	-48	-	-	-	-	
	2 5.6	-	257093856 B64	257207-16F	257254-16F	-56	-	-	-	-	
	2 6.4	-	B64	-	-	-64	-	-	-	-	
	3 4.8	257518-48	257092848	257206-16F	259201-16F	257404-48	-	-	-	#11	
	3 5.6	-	257094856 B64	257207-16F	257254-16F	-56	-	-	-	-	
3 6.4	-	B64	-	-	-64	-	-	-	-	-	
4562-03EC	2 4.0	257517-40	257091C40 C48	257206-16F	259201-16F	257403-40 -48	257550-91	257553	257551B	UY128GAS #11	
	2 4.8	-	C48	-	-	-48	-	-	-	-	
	2 5.6	-	257093C56 C64	257207-16F	257254-16F	-56	-	-	-	-	
	2 6.4	-	C64	-	-	-64	-	-	-	-	
	3 4.8	257518-48	257092C48	257206-16F	259201-16F	257404-48	-	-	-	#11	
	3 5.6	-	257094C56 C64	257207-16F	257254-16F	-56	-	-	-	-	
3 6.4	-	C64	-	-	-64	-	-	-	-	-	
4542-03DB	2 4.0	257517-40	257087840 B48	257206-16F	259200-16F	257405-40 -48	257550-91	257553	257551B	UY128GAS #11	
	2 4.8	-	B48	-	-	-48	-	-	-	-	
	2 5.6	-	257089856 B64	257207-16F	257253-16F	-56	-	-	-	-	
	2 6.4	-	B64	-	-	-64	-	-	-	-	
	3 4.8	257518-48	257088848	257206-16F	259200-16F	257406-48	-	-	-	#11	
	3 5.6	-	257090856 B64	257207-16F	257253-16F	-56	-	-	-	-	
3 6.4	-	B64	-	-	-64	-	-	-	-	-	
4542-03DC	2 4.0	257517-40	257087C40 C48	257206-16F	259200-16F	257405-40 -48	257550-91	257553	257551B	UY128GAS #11	
	2 4.8	-	C48	-	-	-48	-	-	-	-	
	2 5.6	-	257089C56 C64	257207-16F	257253-16F	-56	-	-	-	-	
	2 6.4	-	C64	-	-	-64	-	-	-	-	
	3 4.8	257518-48	257088C48	257206-16F	259200-16F	257406-48	-	-	-	#11	
	3 5.6	-	257090C56 C64	257207-16F	257253-16F	-56	-	-	-	-	
3 6.4	-	C64	-	-	-64	-	-	-	-	-	
4542-03EB	2 4.0	257517-40	257091840 B48	257206-16F	259201-16F	257405-40 -48	257550-91	257553	257551B	UY128GAS #11	
	2 4.8	-	B48	-	-	-48	-	-	-	-	
	2 5.6	-	257093856 B64	257207-16F	257254-16F	-56	-	-	-	-	
	2 6.4	-	B64	-	-	-64	-	-	-	-	
	3 4.8	257518-48	257092848	257206-16F	259201-16F	257406-48	-	-	-	#11	
	3 5.6	-	257094856 B64	257207-16F	257254-16F	-56	-	-	-	-	
3 6.4	-	B64	-	-	-64	-	-	-	-	-	
4542-03EC	2 4.0	257517-40	257091C40 C48	257206-16F	259201-16F	257405-40 -48	257550-91	257553	257551B	UY128GAS #11	
	2 4.8	-	C48	-	-	-48	-	-	-	-	
	2 5.6	-	257093C56 C64	257207-16F	257254-16F	-56	-	-	-	-	
	2 6.4	-	C64	-	-	-64	-	-	-	-	
	3 4.8	257518-48	257092C48	257206-16F	259201-16F	257406-48	-	-	-	#10	
	3 5.6	-	257094C56 C64	257207-16F	257254-16F	-56	-	-	-	-	
3 6.4	-	C64	-	-	-64	-	-	-	-	-	

※
 Looper gauge=348
 257550-91
 ↓
 257550E91
 Starting in Sept, 1990

4562-05 GAUGE PARTS LIST (6)
4542-05

MACHINE	GAUGE	NEEDLE HOLDER	NEEDLE PLATE	MAIN FEED DOG	DIFF. FEED DOG	PRESSER FOOT ASS.	LOOPER	NDL GUARD (FRONT)	NDL GUARD (REAR)	NEEDLE SIZE
4562-05BA	2 2.4	257517-24	257049A24	257220-16F	257266-16F	257327A24	257550-91	257553	257551B	UY128GAS
	2 3.2	" -32	" A32	"	"	" A32	"	"	"	" #11
	2 4.0	" -40	257050A40	257221-16F	257267-16F	257328A40	"	"	"	"
	2 4.8	" -48	" A48	"	"	" A48	"	"	"	"
	2 5.6	" -56	257052A56	257222-16F	257268-16F	257329A56	"	"	"	"
	2 6.4	" -64	" A64	"	"	" A64	"	"	"	"
	3 4.8	257518-48	257051A48	257221-16F	257267-16F	257330A48	"	"	"	" #11
	3 5.6	" -56	257053A56	257222-16F	257268-16F	257331A56	"	"	"	"
	3 6.4	" -64	" A64	"	"	" A64	"	"	"	"
	4562-05BB	2 2.4	257517-24	257049B24	257220-16F	257266-16F	257327A24	257550-91	257553	257551B
2 3.2		" -32	" B32	"	"	" A32	"	"	"	" #11
2 4.0		" -40	257050B40	257221-16F	257267-16F	257328A40	"	"	"	"
2 4.8		" -48	" B48	"	"	" A48	"	"	"	"
2 5.6		" -56	257052B56	257222-16F	257268-16F	257329A56	"	"	"	"
2 6.4		" -64	" B64	"	"	" A64	"	"	"	"
3 4.8		257518-48	257051B48	257221-16F	257267-16F	257330A48	"	"	"	" #11
3 5.6		" -56	257053B56	257222-16F	257268-16F	257331A56	"	"	"	"
3 6.4		" -64	" B64	"	"	" A64	"	"	"	"
4542-05BA		2 2.4	257517-24	257049A24	257220-16F	257266-16F	257332A24	257550-91	257553	257551B
	2 3.2	" -32	" A32	"	"	" A32	"	"	"	" #11
	2 4.0	" -40	257050A40	257221-16F	257267-16F	257333A40	"	"	"	"
	2 4.8	" -48	" A48	"	"	" A48	"	"	"	"
	2 5.6	" -56	257052A56	257222-16F	257268-16F	257334A56	"	"	"	"
	2 6.4	" -64	" A64	"	"	" A64	"	"	"	"
	3 4.8	257518-48	257051A48	257221-16F	257267-16F	257335A48	"	"	"	" #11
	3 5.6	" -56	257053A56	257222-16F	257268-16F	257336A56	"	"	"	"
	3 6.4	" -64	" A64	"	"	" A64	"	"	"	"
	4542-05BB	2 2.4	257517-24	257044B24	257220-16F	257266-16F	257332A24	257550-91	257553	257551B
2 3.2		" -32	" B32	"	"	" A32	"	"	"	" #11
2 4.0		" -40	257050B40	257221-16F	257267-16F	257333A40	"	"	"	"
2 4.8		" -48	" B48	"	"	" A48	"	"	"	"
2 5.6		" -56	257052B56	257222-16F	257268-16F	257334A56	"	"	"	"
2 6.4		" -64	" B64	"	"	" A64	"	"	"	"
3 4.8		257518-48	257051B48	257221-16F	257267-16F	257335A48	"	"	"	" #11
3 5.6		" -56	257053B56	257222-16F	257268-16F	257336A56	"	"	"	"
3 6.4		" -64	" B64	"	"	" A64	"	"	"	"

※
 Looper gauge=348
 257550-91
 ↓
 257550F.91
 Starting in Sept, 1990



MACHINE	GAUGE	NEEDLE HOLDER	NEEDLE PLATE	MAIN FEED DOG	DIFF. FEED DOG	PRESSER FOOT ASS.	LOOPER	NDL GUARD (FRONT)	NDL GUARD (REAR)	NEEDLE SIZE
4562-05CA	2 2.4	257517-24	257049A24	257220A16F	257266-16F	257327A24	257550-91	257553	257551B	UY128GAS
	2 3.2	" -32	" A32	"	"	" A32	"	"	"	" #11
	2 4.0	" -40	257050A40	257221A16F	257267-16F	257328A40	"	"	"	" #11
	2 4.8	" -48	" A48	"	"	" A48	"	"	"	"
	2 5.6	" -56	257052A56	257222A16F	257268-16F	257329A56	"	"	"	"
	2 6.4	" -64	" A64	"	"	" A64	"	"	"	"
	3 4.8	257518-48	257051A48	257221A16F	257267-16F	257330A48	"	"	"	" #11
	3 5.6	" -56	257053A56	257222A16F	257268-16F	257331A56	"	"	"	"
	3 6.4	" -64	" A64	"	"	" A64	"	"	"	"
4562-05CB	2 2.4	257517-24	257049B24	257220A16F	257266-16F	257327A24	257550-91	257553	257551B	UY128GAS
	2 3.2	" -32	" B32	"	"	" A32	"	"	"	" #11
	2 4.0	" -40	257050B40	257221A16F	257267-16F	257328A40	"	"	"	"
	2 4.8	" -48	" B48	"	"	" A48	"	"	"	"
	2 5.6	" -56	257052B56	257222A16F	257268-16F	257329A56	"	"	"	"
	2 6.4	" -64	" B64	"	"	" A64	"	"	"	"
	3 4.8	257518-48	257051B48	257221A16F	257267-16F	257330A48	"	"	"	" #11
	3 5.6	" -56	257053B56	257222A16F	257268-16F	257331A56	"	"	"	"
	3 6.4	" -64	" B64	"	"	" A64	"	"	"	"
4542-05CA	2 2.4	257517-24	257049A24	257220A16F	257266-16F	257332A24	257550-91	257553	257551B	UY128GAS
	2 3.2	" -32	" A32	"	"	" A32	"	"	"	" #11
	2 4.0	" -40	257050A40	257221A16F	257267-16F	257333A40	"	"	"	"
	2 4.8	" -48	" A48	"	"	" A48	"	"	"	"
	2 5.6	" -56	257052A56	257222A16F	257268-16F	257334A56	"	"	"	"
	2 6.4	" -64	" A64	"	"	" A64	"	"	"	"
	3 4.8	257518-48	257051A48	257221A16F	257267-16F	257335A48	"	"	"	" #11
	3 5.6	" -56	257053A56	257222A16F	257268-16F	257336A56	"	"	"	"
	3 6.4	" -64	" A64	"	"	" A64	"	"	"	"
4542-05CB	2 2.4	257517-24	257049B24	257220A16F	257266-16F	257332A24	257550-91	257553	257551B	UY128GAS
	2 3.2	" -32	" B32	"	"	" A32	"	"	"	" #11
	2 4.0	" -40	257050B40	257221A16F	257267-16F	257333A40	"	"	"	"
	2 4.8	" -48	" B48	"	"	" A48	"	"	"	"
	2 5.6	" -56	257052B56	257222A16F	257268-16F	257334A56	"	"	"	"
	2 6.4	" -64	" B64	"	"	" A64	"	"	"	"
	3 4.8	257518-48	257051B48	257221A16F	257267-16F	257335A48	"	"	"	" #11
	3 5.6	" -56	257053B56	257222A16F	257268-16F	257336A56	"	"	"	"
	3 6.4	" -64	" B64	"	"	" A64	"	"	"	"

※ Looper gauge=348 Starting in Sept, 1990
257550-91 → 257550E91

4500-06 GAUGE PARTS LIST (8)



MACHINE	GAUGE	NEEDLE HOLDER	NEEDLE PLATE	MAIN FEED DOG	DIFF. FEED DOG	PRESSER FOOT ASS.	LOOPER	NDL GUARD (FRONT)	NDL GUARD (REAR)	NEEDLE SIZE
4562-06BA	2 3.2	257517-32	257044A32	257214-16F	257260-16F	257337A24	257550-91	257553	257551B	UY128GAS
	2 4.0	" -40	257045A40	257215-16F	257261-16F	257338A40	"	"	"	" #11
	2 4.8	" -48	" A48	"	"	" A48	"	"	"	"
	2 5.6	" -56	257047A56	257216-16F	257262-16F	257339A56	"	"	"	"
	2 6.4	" -64	" A64	"	"	" A64	"	"	"	"
	3 4.8	257518-48	257046A48	257215-16F	257261-16F	257340A48	"	"	"	" #11
	3 5.6	" -56	257048A56	257216-16F	257262-16F	257341A56	"	"	"	"
3 6.4	" -64	" A64	"	"	" A64	"	"	"	"	
4562-06BB	2 3.2	257517-24	257044B32	257214-16F	257260-16F	257337A32	257550-91	257553	257551B	UY128GAS
	2 4.0	" -40	257045B40	257215-16F	257261-16F	257338A40	"	"	"	" #11
	2 4.3	" -48	" B48	"	"	" A48	"	"	"	"
	2 5.6	" -56	257047B56	257216-16F	257262-16F	257339A56	"	"	"	"
	2 6.4	" -64	" B64	"	"	" A64	"	"	"	"
	3 4.8	257518-48	257046B48	257215-16F	257261-16F	257340A48	"	"	"	" #11
	3 5.6	" -56	257048B56	257216-16F	257262-16F	257341A56	"	"	"	"
3 6.4	" -64	" B64	"	"	" A64	"	"	"	"	
4542-06BA	2 3.2	257517-32	257044A32	257214-16F	257260-16F	257342A24	257550-91	257553	257551B	UY128GAS
	2 4.0	" -40	257045A40	257215-16F	257261-16F	257343A40	"	"	"	" #11
	2 4.8	" -48	" A48	"	"	" A48	"	"	"	"
	2 5.0	" -56	257047A56	257216-16F	257262-16F	257344A56	"	"	"	"
	2 6.4	" -64	" A64	"	"	" A64	"	"	"	"
	3 4.8	257518-48	257046A48	257215-16F	257261-16F	257345A48	"	"	"	" #11
	3 5.6	" -56	257043A56	257216-16F	257216-16F	257346A56	"	"	"	"
3 6.4	" -64	" A64	"	"	" A64	"	"	"	"	
4542-06BB	2 3.2	257517-24	257044B32	257214-16F	257260-16F	257342A32	257550-91	257553	257551B	UY128GAS
	2 4.0	" -40	257045B40	257215-16F	257261-16F	257343A40	"	"	"	"
	2 4.8	" -48	" B48	"	"	" A48	"	"	"	"
	2 5.6	" -56	257047B56	257216-16F	257262-16F	257344A56	"	"	"	"
	2 6.4	" -64	" B64	"	"	" A64	"	"	"	"
	3 4.8	257518-48	257046B48	257215-16F	257261-16F	257345A48	"	"	"	" #11
	3 5.6	" -56	257048B56	257216-16F	257262-16F	257346A56	"	"	"	"
3 6.4	" -64	" B64	"	"	" A64	"	"	"	"	

※
 Looper gauge=348
 257550-91
 ↓
 257550E91
 Starting in Sept, 1990

4500-07 GAUGE PARTS LIST (9)



MACHINE	GAUGE	NEEDLE HOLDER	NEEDLE PLATE	MAIN FEED DOG	DIFF. FEED DOG	PRESSER FOOT ASS.	LOOPER	NDL GUARD (FRONT)	NDL GUARD (REAR)	NEEDLE SIZE
4562-07BA	2 3.2	257517-32	257044A32	257214-16F	257260-16F	257337A32	257550-91	257553	257551B	UY128GAS
	2 4.0	" -40	257045A40	257215-16F	257261-16F	257338A40	"	"	"	" #11
	2 4.8	" -48	" A48	"	"	" A48	"	"	"	"
	2 5.6	" -56	257047A56	257216-16F	257262-16F	257339A56	"	"	"	"
	2 6.4	" -64	" A64	"	"	" A64	"	"	"	"
	3 4.8	257518-48	257046A48	257215-16F	257261-16F	257340A48	"	"	"	" #11
	3 5.6	" -56	257048A56	257216-16F	257262-16F	257341A56	"	"	"	"
	3 6.4	" -64	" A64	"	"	" A64	"	"	"	"
4562-07BB	2 3.2	257517-32	257044B32	257214-16F	257260-16F	257337A32	"	"	"	UY128GAS
	2 4.0	" -40	257045B40	257215-16F	257261-16F	257338A40	"	"	"	" #11
	2 4.8	" -48	" B48	"	"	" A48	"	"	"	"
	2 5.6	" -56	257047B56	257216-16F	257262-16F	257339A56	"	"	"	"
	2 6.4	" -64	" B64	"	"	" A64	"	"	"	"
	3 4.8	257518-48	257046B48	257215-16F	257261-16F	257340A48	"	"	"	"
	3 5.6	" -56	257048B56	257216-16F	257262-16F	257341A56	"	"	"	"
	3 6.4	" -64	" B64	"	"	" A64	"	"	"	"
4542-07BA	2 3.2	257517-32	257044A32	257214-16F	257260-16F	257342A32	257550-91	257553	257551B	UY128GAS
	2 4.0	" -40	257045A40	257215-16F	257261-16F	257343A40	"	"	"	" #11
	2 4.8	" -48	" A48	"	"	" A48	"	"	"	"
	2 5.6	" -56	257047A56	257216-16F	257262-16F	257344A56	"	"	"	"
	2 6.4	" -64	" A64	"	"	" A64	"	"	"	"
	3 4.8	257518-48	257046A48	257215-16F	257261-16F	257345A48	"	"	"	"
	3 5.6	" -56	257048A56	257216-16F	257262-16F	257346A56	"	"	"	"
	3 6.4	" -64	" A64	"	"	" A64	"	"	"	"
4542-07BB	2 3.2	257517-32	257044B32	257214-16F	257260-16F	257342A24	257550-91	257553	257551B	UY128GAS
	2 4.0	" -40	257045B40	257215-16F	257261-16F	257343A40	"	"	"	"
	2 4.8	" -48	" B48	"	"	" A48	"	"	"	"
	2 5.6	" -56	257047B56	257216-16F	257262-16F	257344A56	"	"	"	"
	2 6.4	" -64	" B64	"	"	" A64	"	"	"	"
	3 4.8	257518-48	257046B48	257215-16F	257261-16F	257345A48	"	"	"	" #11
	3 5.6	" -56	257048B56	257216-16F	257262-16F	257346A56	"	"	"	"
	3 6.4	" -64	" B64	"	"	" A64	"	"	"	"

※
 Looper gauge=348
 257550-91
 ↓
 257550E91
 Starting in Sept, 1990











4562-08 GAUGE PARTS LIST (10)

MACHINE	GAUGE	NEEDLE HOLDER	NEEDLE PLATE	MAIN FEED DOG	DIFF. FEED DOG	PRESSER FOOT ASS.	LOOPER	NDL GUARD (FRONT)	NDL GUARD (REAR)	NEEDLE SIZE
4562-08AB	2 4.0	257517-40	257084B40	257206-16F	259209-16F	257300A40	257550-91	257553	257551B	UY128GAS
	2 4.8	" -48	" B48	"	"	" A48	"	"	"	" #11
	3 5.6	257518-56	257095B56	257207-16F	259210-16F	257301A56	"	"	"	" #11
	3 6.4	" -64	" B64	"	"	" A64	"	"	"	" #11
4562-08AC	2 4.0	257517-40	257084C40	257206-16F	259209-16F	257300A40	257550-91	257553	257551B	UY128GAS
	2 4.8	" -48	" C48	"	"	" A48	"	"	"	" #11
	3 5.6	257518-56	257095C56	257207-16F	259210-16F	257301A56	"	"	"	" #11
	3 6.4	" -64	" C64	"	"	" A64	"	"	"	" #11
4542-08AB	2 4.0	257517-40	257084B40	257206-16F	259209-16F	257302A40	257550-91	257553	257551B	UY128GAS
	2 4.8	" -48	" B48	"	"	" A48	"	"	"	" #11
	3 5.6	257518-56	257095B56	257207-16F	259210-16F	257303A56	"	"	"	" #11
	3 6.4	" -64	" B64	"	"	" A64	"	"	"	" #11
4542-08AC	2 4.0	257517-40	257084C40	257206-16F	259209-16F	257302A40	257550-91	257553	257551B	UY128GAS
	2 4.8	" -48	" C48	"	"	" A48	"	"	"	" #11
	3 5.6	257518-56	257095C56	257207-16F	259210-16F	257303A56	"	"	"	" #11
	3 6.4	" -64	" C64	"	"	" A64	"	"	"	" #11

4562-21 GAUGE PARTS LIST (10)

MACHINE	GAUGE	NEEDLE HOLDER	NEEDLE PLATE	MAIN FEED DOG	DIFF. FEED DOG	PRESSER FOOT ASS.	LOOPER	NDL GUARD (FRONT)	NDL GUARD (REAR)	NEEDLE SYSTEM	NEEDLE SIZE
4562-21BA	356	257518-56	257022A56	257207-16F	257259-16F	257316A56	257550A91	257553	257551B	UY128GAS	#12
	364	" -64	" 64	"	"	" 64	"	"	"	"	"
4562-21BB	356	257518-56	257022B56	257207-16F	257259-16F	257316A56	257550A91	257553	257551B	UY128GAS	#12
	364	" -64	" 64	"	"	" 64	"	"	"	"	"
4561-22AC	356	257518-56	257019C56	257207-16F	257259-16F	257316A56	257550-91	257553	257551	DPX17	#18

4500-01DB GAUGE PARTS LIST

										
MACHINE	GAUGE	NEEDLE HOLDER	NEEDLE PLATE	MAIN FEED DOG	DIFF. FEED DOG	PRESSER FOOT ASS.	LOOPER	NDL GUARD (FRONT)	NDL GUARD (REAR)	NEEDLE SIZE
4562-01DB (4561-01DB)	460	257513-60	257020-60	257203A16F	257256-16F	257347-60	257550C91	257553	257551A	SMX1014B3 #10

CSMP

INDEX

PART NO.	PEAFF NO	NO. PAGE REF.	PART NO.	PEAFF NO	NO. PAGE REF.	PART NO.	PEAFF NO	NO. PAGE REF.
4543	11-330 955-15	45 5	5161	09-400 068-00	41 49	7020	11-108 177-15	7 50
4545	11-335 085-15	11 10	5184	09-009 054-02	25 28	7020	11-108 177-15	9 21
4545	11-335 085-15	45 53	5187	09-009 601-05	35 26	7020	11-108 177-15	9 23
4546	11-335 166-15	21 52	5187	09-009 601-05	51 13	7020	11-108 177-15	15 16
4547	11-341 901-15	11 21	5198	09-009 054-04	7 2	7020	11-108 177-15	21 21
4547	11-341 901-15	11 21	5234	09-009 065-83	51 11	7020	11-108 177-15	27 5
4547	11-341 901-15	11 27	5242	09-009 601-06	7 10	7020	11-108 177-15	39 8
4547	11-341 901-15	11 29	5316	09-009 601-16	23 6	7020	11-108 177-15	47 35
4547	11-341 901-15	11 33	5317	09-009 601-17	21 13	7020	11-108 177-15	49 30
4547	11-341 901-15	13 19	5325	09-400 069-00	15 8	7021	11-108 180-15	7 4
4547	11-341 901-15	13 22	5375	09-009 817-16	15 24	7021	11-108 180-15	7 9
4547	11-341 901-15	13 24	5386	09-400 070-00	25 7	7021	11-108 180-15	9 2
4547	11-341 901-15	13 27	5447	09-009 826-61	29 41	7021	11-108 180-15	9 5
4547	11-341 901-15	27 13	5447	09-009 826-61	53 24	7021	11-108 180-15	13 11
4547	11-341 901-15	37	5476	09-009 612-45	51 34	7021	11-108 180-15	15 15
4547	11-341 901-15	45 31	5476	09-009 612-45	57 3	7021	11-108 180-15	23 22
4547	11-341 901-15	47 20	5476	09-009 612-45	157 3	7021	11-108 180-15	37 57
4549	01-179 367-15	25 37	5476	09-009 612-45	257 3	7022	11-108 183-15	27 4
4554	11-330 082-15	15 3	5476	09-009 612-45	357 3	7023	11-108 186-15	7 32
4554	11-330 082-15	31 19	5486	09-009 612-53	23 29	7023	11-108 186-15	33 19
4554	11-330 082-15	33 16	5526	09-400 072-00	31 42	7023	11-108 186-15	35 22
4554	11-330 082-15	33 21	5526	09-400 072-00	33 13	7023	11-108 186-15	47 6
4554	11-330 082-15	33 25	5526	09-400 072-00	35 15	7025	11-108 192-15	25 9
4554	11-330 082-15	35 20	5540	09-400 073-00	41 30	7026	11-108 198-15	37 14
4554	11-330 082-15	35 25	5590	09-009 734-83	21 3	7027	11-108 222-15	41 19
4554	11-330 082-15	35 39	5590	09-009 734-83	21 6	7027	11-108 222-15	55 10
4554	11-330 082-15	49 36	5612	09-400 074-00	29	7028	11-108 225-15	33 2
4554	11-330 082-15	49 38	7008	11-108 087-15	45 35	7028	11-108 225-15	41 26
4554	11-330 082-15	51 27	7009	11-108 090-15	7 44	7028	11-108 225-15	43 28
4554	11-330 082-15	51 29	7009	11-108 090-15	31 15	7028	11-108 225-15	45 49
4555	09-400 060-00	11 22	7009	11-108 090-15	31 19	7031	11-108 849-15	15
4555	09-400 060-00	11 32	7009	11-108 090-15	45 29	7031	11-108 849-15	15 72
4555	09-400 060-00	13 18	7010	11-108 093-15	25 15	7031	11-108 849-15	17 23
4555	09-400 060-00	13 26	7010	11-108 093-15	31 48	7031	11-108 849-15	21 54
4556	09-400 061-00	11 58	7010	11-108 093-15	39 12	7031	11-108 849-15	33 6
4556	09-400 061-00	13 31	7010	11-108 093-15	45 51	7031	11-108 849-15	35 6
4802	09-400 064-00	19 27	7010	11-108 093-15	47 17	7031	11-108 849-15	35 9
4803	09-009 612-30	41 12	7010	11-108 093-15	49 41	7031	11-108 849-15	35 17
4803	09-009 612-30	49 34	7011	11-108 096-15	11 18	7032	11-108 855-15	19 7
4803	09-009 612-30	51 25	7011	11-108 096-15	19 17	7033	11-173 225-15	7 30
4803	09-009 612-30	51 38	7013	11-108 137-15	23	7034	11-173 227-15	25 34
4803	09-009 612-30	51 45	7013	11-108 144-15	11 5	7036	11-174 170-15	45 46
4803	09-009 612-30	57 8	7013	11-108 144-15	11 6	7041	09-009 814-31	15 29
4803	09-009 612-30	57 12	7013	11-108 144-15	13 10	7043	11-210 168-15	9 3
4803	09-009 612-30	57 17	7013	11-108 144-15	17 5	7043	11-210 168-15	33 4
4803	09-009 612-30	57 39	7013	11-108 144-15	19 12	7043	11-210 168-15	35 4
4803	09-009 612-30	157 8	7013	11-108 144-15	45 4	7052	01-100 187-15	7 18
4803	09-009 612-30	157 22	7013	11-108 144-15	45 11	7052	01-100 187-15	7 18
4803	09-009 612-30	157 25	7013	11-108 168-15	3 28	7066	01-179 529-17	24 9
4803	09-009 612-30	157 36	7013	11-108 168-15	7 54	7066	01-179 529-17	24 9
4803	09-009 612-30	257 8	7017	11-108 168-15	17 21	7069	91-700 335-15	43 51
4803	09-009 612-30	257 22	7017	11-108 168-15	17 26	7074	09-400 080-00	49 24
4803	09-009 612-30	257 25	7017	11-108 168-15	29 5	7074	09-400 080-00	49 27
4803	09-009 612-30	257 30	7017	11-108 168-15	37 5	7075	09-400 081-00	7 16
4803	09-009 612-30	357 8	7017	11-108 168-15	39 19	7077	09-400 083-00	31 17
4803	09-009 612-30	357 22	7017	11-108 168-15	49 52	7079	09-400 085-00	41 21
4803	09-009 612-30	357 25	7018	11-108 171-15	3 9	7079	09-400 085-00	41 24
4803	09-009 612-30	357 30	7018	11-108 171-15	7 29	7079	09-400 085-00	43 12
4805	09-400 065-00	19 21	7018	11-108 171-15	7 56	7079	09-400 085-00	43 53
4805	09-400 065-00	25 38	7018	11-108 171-15	9 28	7080	09-400 086-00	21 62
4805	09-400 065-00	27 21	7018	11-108 171-15	33 36	7081	09-400 087-00	17 33
4805	09-400 065-00	57 18	7018	11-108 171-15	35 39	7081	09-400 087-00	23 14
4805	09-400 065-00	57 35	7018	11-108 171-15	37 30	7082	09-400 088-00	11 35
4805	09-400 065-00	157 18	7018	11-108 171-15	37 40	7082	09-400 088-00	15 21
4805	09-400 065-00	157 35	7018	11-108 171-15	37 46	7083	09-400 089-00	47 18
4805	09-400 065-00	257 18	7018	11-108 171-15	43 26	7083	09-400 089-00	47 26
4805	09-400 065-00	257 35	7018	11-108 171-15	43 31	7084	09-400 090-00	3 3
4805	09-400 065-00	357 18	7018	11-108 171-15	49 54	7084	09-400 090-00	3 6
4805	09-400 065-00	357 35	7019	11-108 174-15	7 7	7085	09-400 091-00	19 34
4821	12-024 151-15	9 24	7019	11-108 174-15	7 18	7086	09-400 092-00	19 33
4821	12-024 151-15	37 44	7019	11-108 174-15	9 26	7087	09-400 093-00	33 34
4904	09-009 612-31	55 13	7019	11-108 174-15	15 20	7087	09-400 093-00	35 37
4905	09-009 612-32	55 15	7019	11-108 174-15	17	7089	09-400 094-00	7 19
4913	09-009 618-05	41 39	7019	11-108 171-15	21 17	7089	09-400 094-00	9 29
4913	09-009 618-05	51 32	7019	11-108 174-15	23 13	7092	09-400 095-00	23
5048	09-009 053-61	27 19	7019	11-108 174-15	25 36	7093	09-400 091-00	55 7
5053	09-009 053-62	39 6	7019	11-108 174-15	29 2	7102	09-400 092-00	57
5058	09-009 064-85	13 5	7019	11-108 174-15	29 29	7102	09-400 092-00	57 12
5084	09-009 053-76	17 8	7019	11-108 174-15	31 2	7102	09-400 092-00	157
5084	09-009 053-76	19 26	7019	11-108 174-15	31 22	7102	09-400 092-00	157 12
5084	09-009 053-76	21 10	7019	11-108 174-15	31 27	7102	09-400 092-00	257
5084	09-009 053-76	25 22	7019	11-108 174-15	31 30	7102	09-400 092-00	257 12
5084	09-009 053-76	45 13	7019	11-108 174-15	31 32	7102	09-400 092-00	357
5109	09-009 053-87	45 33	7019	11-108 174-15	31 34	7102	09-400 092-00	357 12
5113	09-009 054-70	41 29	7019	11-108 174-15	31 36	7105	09-009 820-15	37 13
5116	09-400 067-00	51 8	7019	11-108 171-15	49 3	7110	09-009 827-40	31 52
5117	09-009 053-88	47 28	7019	11-108 171-15	49 7	7120	09-009 819-98	7 39
5118	09-009 053-89	25 5	7019	11-108 174-15	51 19	9050	09-009 815-93	55 16
5138B	09-009 067-17	37 60	7019	11-108 174-15	53 25	9105	09-009 823-11	59 25
5141	09-009 600-24	49 9	7020	11-108 177-15	7 41	137108	09-400 096-00	31 40

INDEX

PART NO.	PAFF-NO	NO. PAGE REF.	PART NO.	PAFF-NO	NO. PAGE REF.	PART NO.	PAFF-NO	NO. PAGE REF.
257015B24	09-009 817-70	94	257045B48	09-009 818-42	101	257095B56	09-009 828-33	103
257015B24	09-009 817-70	95	257045B48	09-009 818-42	102	257095B64	09-009 828-34	103
257015B32	09-009 817-71	94	257046A48	09-009 818-37	101	257095C56	09-009 821-34	103
257015B32	09-009 817-71	95	257046A48	09-009 818-37	102	257095C64	09-009 828-35	103
257015B40	09-009 817-72	94	257046B48	09-009 818-45	101	257200-16F	09-400 688-00	97
257015B40	09-009 817-72	95	257046B48	09-009 818-45	102	257203A16F	09-009 842-80	104
257015B48	09-009 816-07	94	257047A56	09-009 818-35	101	257206-16F	09-009 816-14	94
257015B48	09-009 816-07	95	257047A56	09-009 818-35	102	257206-16F	09-009 816-14	95
257015C24	09-009 817-77	94	257047A64	09-009 818-36	101	257206-16F	09-009 816-14	98
257015C24	09-009 817-77	95	257047A64	09-009 818-36	102	257206-16F	09-009 816-14	103
257015C32	09-009 817-78	94	257047B56	09-009 818-43	101	257207-16F	09-009 816-15	94
257015C32	09-009 817-78	95	257047B56	09-009 818-43	102	257207-16F	09-009 816-15	95
257015C40	09-009 817-79	94	257047B64	09-009 818-44	101	257207-16F	09-009 816-15	98
257015C40	09-009 817-79	95	257047B64	09-009 818-44	102	257207-16F	09-009 816-15	103
257015C48	09-009 817-80	94	257048A56	09-009 818-38	101	257214-16F	09-009 816-17	96
257015C48	09-009 817-80	95	257048A56	09-009 818-38	102	257214-16F	09-009 816-17	101
257016A48	09-009 817-67	94	257048A64	09-009 818-39	101	257214-16F	09-009 816-17	102
257016A48	09-009 817-67	95	257048A64	09-009 818-39	102	257215-16F	09-009 813-49	96
257016B48	09-009 817-75	94	257048B56	09-009 818-46	101	257215-16F	09-009 813-49	101
257016B48	09-009 817-75	95	257048B56	09-009 818-46	102	257215-16F	09-009 813-49	102
257016C48	09-009 817-83	94	257048B64	09-009 818-47	101	257216-16F	09-009 813-52	96
257016C48	09-009 817-83	95	257048B64	09-009 818-47	102	257216-16F	09-009 816-15	101
257017A56	09-009 817-65	94	257049A24	09-009 818-71	99	257216-16F	09-009 813-52	102
257017A56	09-009 817-65	95	257049A24	09-009 818-71	100	257220-16F	09-009 812-82	99
257017A64	09-009 817-66	94	257049A32	09-009 818-72	99	257220-16F	09-009 828-36	100
257017A64	09-009 817-66	95	257049A32	09-009 818-72	100	257221-16F	09-009 816-18	99
257017B56	09-009 817-73	94	257049B24	09-009 818-80	99	257221-16F	09-009 828-37	100
257017B56	09-009 817-73	95	257049B24	09-009 818-80	100	257222-16F	09-009 816-19	99
257017B64	09-009 817-74	94	257049B32	09-009 812-81	99	257222-16F	09-009 828-38	100
257017B64	09-009 817-74	95	257049B32	09-009 812-81	100	257253-16F	09-009 817-95	97
257017C56	09-009 817-81	94	257050A40	09-009 818-73	99	257254-16F	09-009 817-96	97
257017C56	09-009 817-81	95	257050A40	09-009 818-73	100	257255-16F	09-009 842-84	104
257017C64	09-009 817-82	94	257050A48	09-009 818-74	99	257255-16F	09-009 816-20	94
257017C64	09-009 817-82	95	257050A48	09-009 818-74	100	257258-16F	09-009 816-20	95
257018A56	09-009 817-68	94	257050B40	09-009 816-12	99	257259-16F	09-009 816-21	94
257018A56	09-009 817-68	95	257050B40	09-009 816-12	100	257259-16F	09-009 816-21	95
257018A64	09-009 817-69	94	257050B48	09-009 818-81	99	257259-16F	09-009 816-21	103
257018A64	09-009 817-69	95	257050B48	09-009 818-81	100	257260-16F	09-009 816-22	96
257018B56	09-009 816-08	94	257051A48	09-009 818-77	99	257260-16F	09-009 816-22	101
257018B56	09-009 816-08	95	257051A48	09-009 818-77	100	257267-16F	09-009 816-23	100
257018B64	09-009 817-76	94	257051B48	09-009 819-72	99	257268-16F	09-009 816-24	99
257018B64	09-009 817-76	95	257051B48	09-009 819-72	100	257268-16F	09-009 816-24	100
257018C56	09-009 817-84	94	257052A56	09-009 818-75	99	257300A24	09-009 817-86	94
257018C56	09-009 817-84	95	257052A56	09-009 818-75	100	257300A32	09-009 817-87	94
257018C64	09-009 817-85	94	257052A64	09-009 818-76	99	257300A40	09-009 817-88	94
257018C64	09-009 817-85	95	257052A64	09-009 818-76	100	257300A48	09-009 817-88	103
257019C56	09-400 829-29	103	257052B56	09-009 818-82	99	257300A48	09-009 817-89	94
257020-60	09-009 842-79	104	257052B56	09-009 818-82	100	257300A48	09-009 817-89	103
257022A56	09-009 818-64	103	257052B64	09-009 818-83	99	257300A56	09-009 817-90	94
257022A64	09-009 818-65	103	257052B64	09-009 818-83	100	257300A64	09-009 817-91	94
257022B56	09-009 818-66	103	257053A56	09-009 818-78	99	257301A48	09-009 817-92	94
257022B64	09-009 818-67	103	257053A56	09-009 818-78	100	257301A56	09-009 817-93	94
257029A24	09-009 819-70	96	257053A64	09-009 818-79	99	257301A56	09-009 817-93	103
257029A32	09-009 817-97	96	257053A64	09-009 818-79	100	257301A61	09-009 816-25	94
257029B24	09-009 818-05	96	257053B56	09-009 816-13	99	257301A64	09-009 816-25	103
257029B32	09-009 816-11	96	257053B56	09-009 816-13	100	257302A24	09-009 819-74	95
257029C24	09-009 818-10	96	257053B64	09-009 818-85	99	257302A32	09-009 820-41	95
257029C32	09-009 812-78	96	257053B64	09-009 818-85	100	257302A40	09-009 820-42	95
257030A40	09-009 817-98	96	257084B40	09-009 828-03	103	257302A40	09-009 820-42	103
257030A48	09-009 817-99	96	257084B48	09-009 828-04	103	257302A48	09-009 820-43	95
257030B40	09-009 813-48	96	257084C40	09-009 820-85	103	257302A48	09-009 820-43	103
257030B48	09-009 818-06	96	257084C48	09-009 821-33	103	257302A56	09-009 820-44	95
257030C40	09-009 818-11	96	257087B40	09-009 828-05	98	257302A64	09-009 820-45	95
257030C48	09-009 818-12	96	257087B48	09-009 828-06	98	257303A48	09-009 819-75	95
257031A48	09-009 818-02	96	257087C40	09-009 828-07	98	257303A56	09-009 820-46	95
257031B48	09-009 818-09	96	257087C48	09-009 828-08	98	257303A56	09-009 820-46	103
257031C48	09-009 818-15	96	257088B48	09-009 828-09	98	257303A64	09-009 820-47	95
257032A56	09-009 818-00	96	257088C48	09-009 828-10	98	257303A64	09-009 820-47	103
257032A64	09-009 818-01	96	257089B56	09-009 828-11	98	257312-40	09-400 683-00	97
257032B56	09-009 818-07	96	257089B64	09-009 828-12	98	257312-48	09-400 684-00	97
257032B64	09-009 818-08	96	257089C56	09-009 828-13	98	257312-56	09-400 685-00	97
257032C56	09-009 818-13	96	257089C64	09-009 828-14	98	257312-64	09-400 686-00	97
257033A56	09-009 818-03	96	257090B56	09-009 828-15	98	257313-48	09-400 687-00	97
257033A64	09-009 818-04	96	257090B64	09-009 828-16	98	257313-56	09-400 688-00	97
257033B56	09-009 816-42	96	257090C56	09-009 828-17	98	257313-64	09-400 689-00	97
257033B64	09-009 813-51	96	257090C64	09-009 828-18	98	257314-40	09-400 690-00	97
257033C56	09-009 818-16	96	257091B40	09-009 828-19	98	257314-48	09-400 691-00	97
257033C64	09-009 818-17	96	257091B48	09-009 828-20	98	257314-56	09-400 692-00	97
257044A32	09-009 818-32	101	257091C40	09-009 828-21	98	257314-64	09-400 693-00	97
257044A32	09-009 818-32	102	257091C48	09-009 828-22	98	257092B48	09-009 828-23	98
257044B32	09-009 818-40	99	257092C48	09-009 828-24	98	257093B56	09-009 828-25	98
257044B32	09-009 818-40	101	257093B56	09-009 828-25	98	257093B64	09-009 828-26	98
257044B32	09-009 818-40	102	257093C56	09-009 828-27	98	257093C64	09-009 828-28	98
257045A40	09-009 818-33	101	257094A56	09-009 828-29	98	257094B56	09-009 828-30	98
257045A40	09-009 818-33	102	257094B64	09-009 828-30	98	257094C56	09-009 828-31	98
257045A48	09-009 818-34	101	257094C64	09-009 828-32	98			
257045A48	09-009 818-34	102						
257045B40	09-009 818-41	101						
257045B40	09-009 818-41	102						

INDEX

PART NO.	PFAFF-NO	PAGE	NO. REF.	PART NO.	PFAFF-NO	PAGE	NO. REF.	PART NO.	PFAFF-NO	PAGE	NO. REF.
306364	09-400	422-00	49	12							
306376	09-400	423-00	49	18							
306377	09-400	424-00	49	19							
306378	09-400	425-00	49	16							
306394	09-400	427-00	45	32							
306462	09-400	428-00	51	42							
306463	09-400	429-00	51	40							
306464	09-400	430-00	51	39							
306466-CA	09-009	820-48	51	33							
306467	09-400	432-00	51	46							
306468-CA	09-009	820-49	51	31							
306469A9C	09-400	433-00	51	30							
306473-JA	09-400	796-00	55	12							
306474	09-400	797-00	55								
306474A	09-009	828-66	55	14							
306500	09-400	434-00	47	24							
306568	09-400	435-00	47	27							
306728	09-400	436-00	43	50							
306920	09-400	437-00	43	29							
9A3002	09-009	814-81	37	64							

