

Pfaff

Mauser Spezial	503	4
Mauser Spezial	504	4
Mauser Spezial	512	4
Mauser Spezial	514	4
Mauser Spezial	515	4
Mauser Spezial	516	4

PFAFF

MAUSER SPEZIAL

503-4; 504-4

512-4; 514-4

515-4; 516-4

Teilleiste

List of parts

Liste de pièces

Lista de piezas

CSMP

Achtung!

Ersatzteile bitte nur mit den im Index aufgeführten **PFAFF-NUMMERN** Bestellen (siehe Seiten 135 bis 141).

Important!

Veillez commander les pièces de rechange uniquement avec leur référence complète précisée à l'index (pages 135 à 141).

Important note:

For spare part orders please only use the **PFAFF-NUMBERS** listed in the index (pages 135 to 141).

Atencion!

Sírvanse hacer sus pedidos sólo con los **NUMEROS-PFAFF** indicados en el índice (véanse las páginas 135 à 141).

TABLE OF CONTENTS

	Page
MACHINE BED FRAME	2- 3
COVER (1) ~ (3)	4- 9
CRANKSHAFT DRIVE MECHANISM (1) ~ (3)	10- 15
NEEDLE DRIVE MECHANISM (1) ~ (3)	16- 21
UPPER LOOPER DRIVE MECHANISM (1), (2)	22- 25
LOWER LOOPER DRIVE MECHANISM	26- 27
CHAINSTITCH LOOPER DRIVE MECHANISM (1), (2)	28- 31
FEED MECHANISM (1) ~ (3)	32- 37
KNIFE DRIVE MECHANISM	38- 39
PRESSER FOOT MECHANISM (1) ~ (3)	40- 45
LUBRICATION MECHANISM	46- 47
H. R. DEVICE (OPTION)	48- 49
ATTACHMENT FOR PIPING (1) ~ (3)	50- 55
ATTACHMENT FOR TAPE	56- 57
ATTACHMENT FOR SHIRring	58- 59
ATTACHMENT	60- 61
ATTACHMENT FOR SHIRring (OPTION)	62- 63
ATTACHMENT (OPTION)	64- 65
PARTS FOR SEMI-SUBMERGED INSTALLATION	66- 67
THREAD STAND	68- 69
ACCESSORIES	70- 71
PIPING FOOT/OTHERS	72- 73
GAUGE PARTS CONSTRUCTION CHARTS	74-123
GAUGE PARTS LISTS	124-132
NEEDLE SIZE AND UPPER LOOPER (SPREADER)	133
LIST OF MAIN FEED DOG COMPLETE	133
PART NUMBER INDEX	135-141

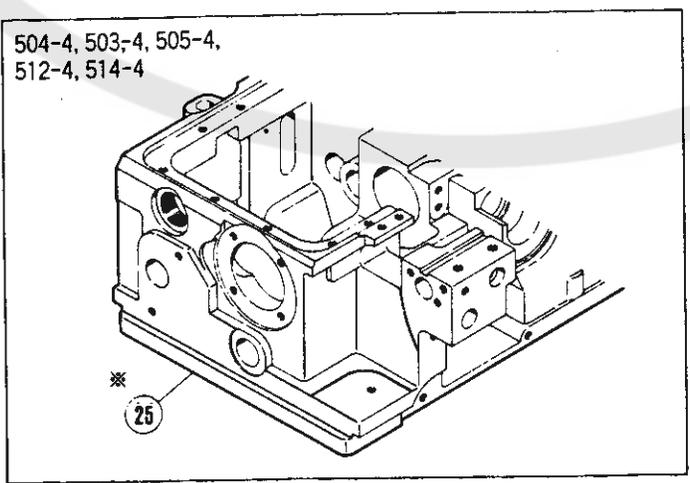
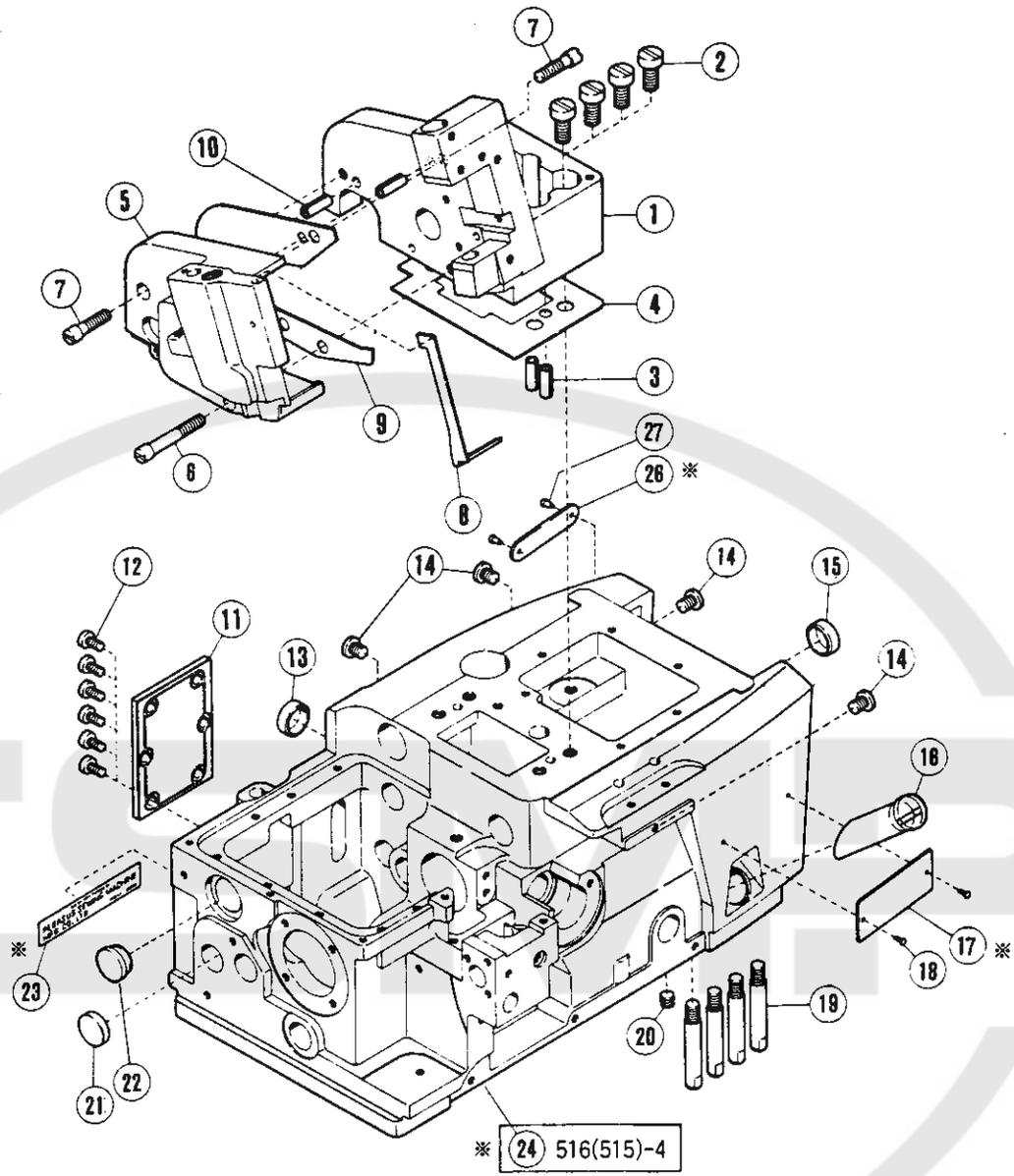

MACHINE BED FRAME

REF. NO.	PART NO.	PFAFF-NO.	NAME	QT.
1	208602-FD	09-009833-62	MACHINE ARM (RIGHT)	1
2	5078	09-009053-69	SCREW	4
3	201002	09-009601-58	PIN	2
4	204251	09-009064-67	GASKET	1
5	208603-FD	09-009833-63	MACHINE ARM (LEFT)	1
6	5237	09-009068-72	SCREW	1
7	5163	09-009054-71	SCREW	2
8	208434	09-009607-56	OIL SHIELD	1
9	208169A	09-009071-15	GASKET	1
10	201002	09-009601-58	PIN	2
11	210005	09-009613-04	COVER PLATE	1
12	5117	09-009053-88	SCREW	6
13	210003	09-009613-03	PLUG	1
14	5332A	09-009813-11	SCREW	4
15	210003	09-009613-03	PLUG	1
16	204003	09-009065-99	OIL SIGHT GAUGE	1
*17	212281A	09-009824-91	TYPE PLATE	1
18	210679	09-009617-74	PIN	2
19	204006	09-009601-82	BED PIN	4
20	2022	09-009051-60	SCREW	1
21	210003	09-009613-03	PLUG	1
22	240162	09-009813-45	PLUG	1
*23	202526	09-009601-69	NAME PLATE	1
*24	208600AFD	09-009833-60	MACHINE BED	1
*25	208601AFD	09-009833-61	MACHINE BED	1
*26	230047A	09-009827-17	SERIAL NUMBER PLATE	1
27	210679	09-009617-74	PIN	2

Notice) Parts with mark * are not for sale.

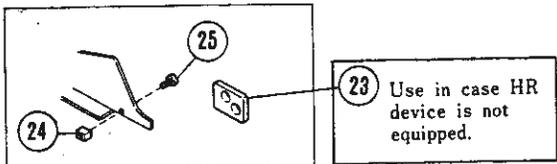
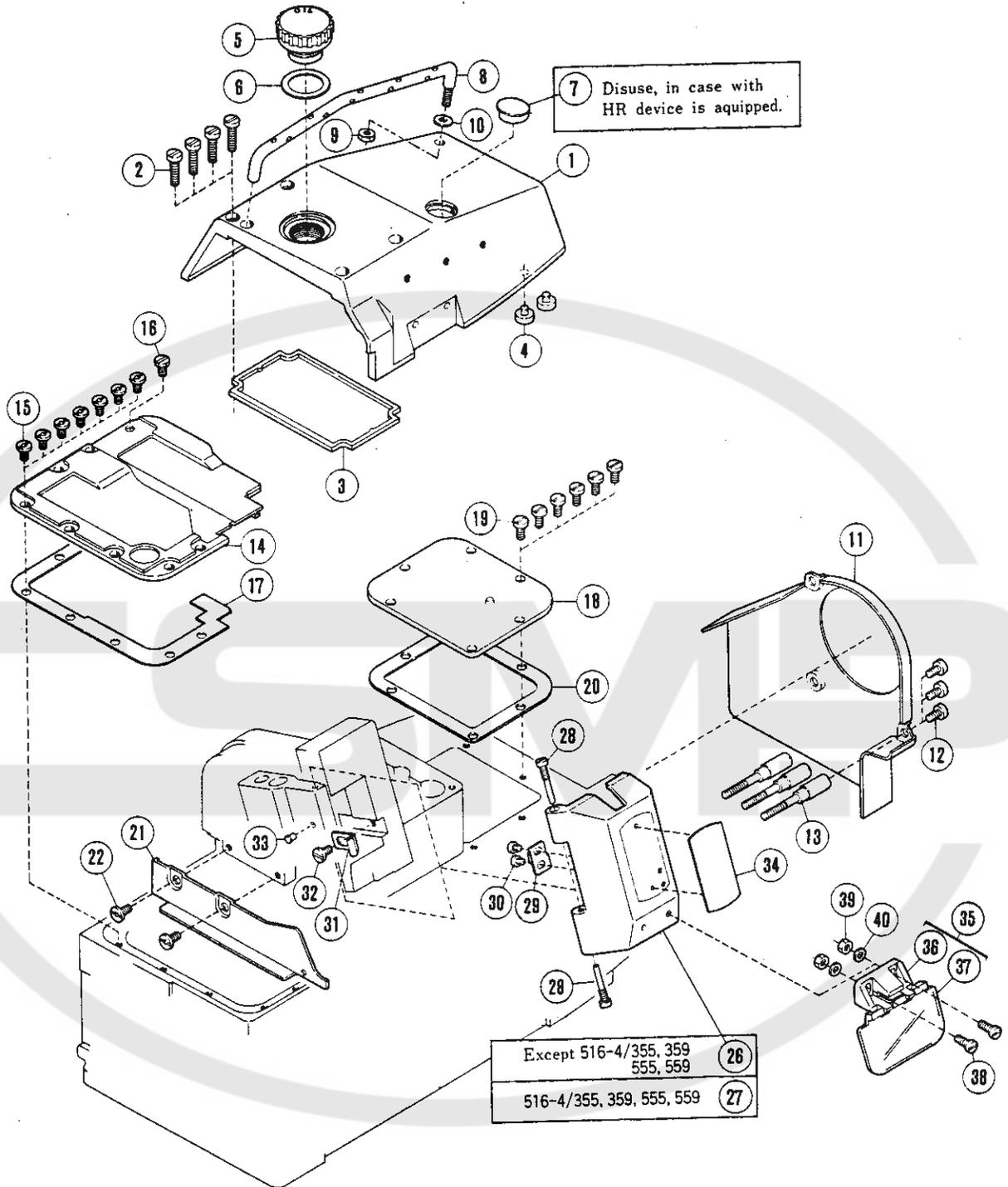

24 25 For Needle Plates without the chaining land.

COVER (1)

REF. NO.	PART NO.	PFAFF-NO.	NAME	QT.
1	208299-HD	09-009833-56	TOP COVER	1
2	5152	09-009053-99	SCREW	4
3	208481	09-009607-63	O RING	1
4	208482	09-009607-64	CUSHION RUBBER	2
5	206457	09-009604-61	OIL SIGHT WINDOW	1
6	206682	09-009800-09	GASKET	1
7	208339	09-009607-20	PLUG	1
8	208802	09-009800-28	THREAD GUIDE BAR	1
9	3044	09-009053-49	NUT	1
10	200098	09-009048-70	WASHER	1
11	205216A	09-009607-76	BELT COVER	1
12	5091	09-009067-20	SCREW	3
13	205217	09-009603-45	SCREW	3
14	208919	09-009800-32	BED PLATE COMPLETE (LEFT)	1
15	4009-1	09-009053-53	SCREW	7
16	5482	09-009612-49	SCREW	1
17	208921	09-009800-33	GASKET	1
18	208341	09-009607-22	BED COVER PLATE (RIGHT)	1
19	5117	09-009053-88	SCREW	6
20	208342	09-009607-23	GASKET	1
21	204848A	09-009068-75	FABRIC GUARD	1
22	4009-1	09-009053-53	SCREW	2
23	204646	09-009067-87	SPACER PLATE	1
24	204681	09-009600-33	SPACER	1
25	2922	09-009065-38	SCREW	1
26	208023AHD	09-009604-65	NEEDLE BAR COVER	1
27	209163-HD	09-009800-47	NEEDLE BAR COVER	1
28	202653	09-009055-00	SCREW	2
29	202689	09-009055-01	FLAT SPRING	1
30	1234	09-009048-23	SCREW	2
31	204223	09-009064-52	FLAT SPRING	1
32	4009-1	09-009053-53	SCREW	1
33	198192	09-009605-10	CUSHION RUBBER	1
34	208726	09-009833-64	NAME PLATE/PFAFF	1
35	208747	09-009603-37	EYE GUARD COMPLETE	1
36	208744	09-009817-02	EYE GUARD BRACKET COMPLETE	1
37	205685	09-009732-75	EYE GUARD	1
38	1175-3	09-009048-14	SCREW	2
39	3091	09-009053-50	NUT	2
40	137906	09-009048-42	WASHER	2

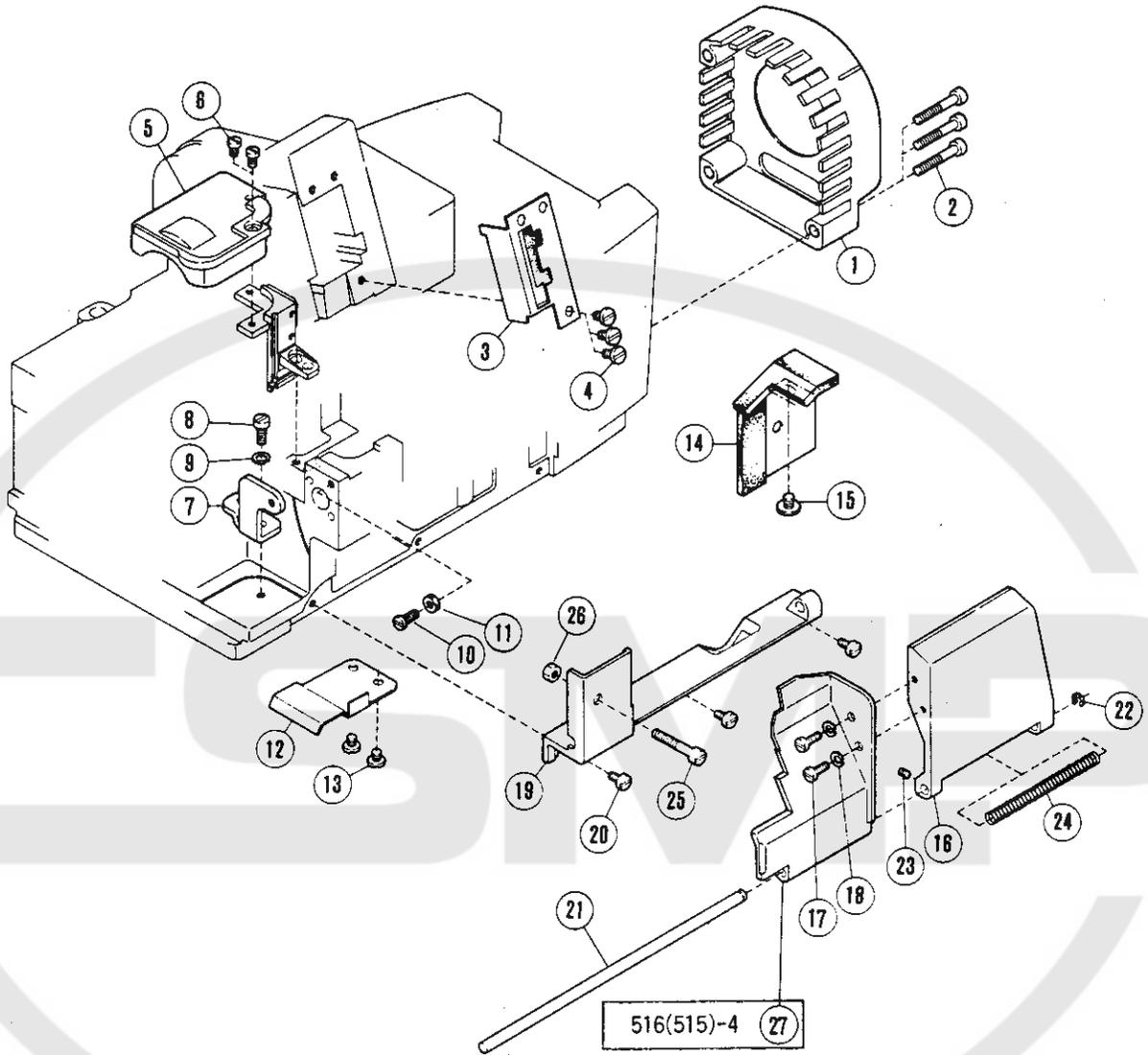

HR DEVICE	※				
	504-4, 503-4, 505-4 (1-needle) (Except 504-4/65)	504-4/65	514-4, 512-4 (2-needle) (NG=1.5mm)	514-4, 512-4 (2-needle) (NG=2.5-3.5mm)	514-4, 512-4 (2-needle) (NG=2.0mm)
YES	29	31	29	33	29
NO	28	30	28	32	34

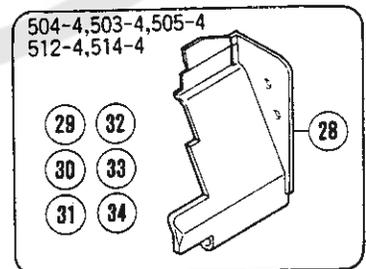

※ 33 Should be used for 512-5/53, 512-4/57 (NG=2.0mm)

COVER (2)

REF. NO.	PART NO.	PFAFF-NO.	NAME	QT.
1	204650A	09-009602-20	COVER	1
2	5094	09-009053-82	SCREW	3
3	208430	09-009607-55	FACE PLATE COMPLETE	1
4	4009-1	09-009053-53	SCREW	3
5	208945	09-009800-34	COVER/FEED ECCENTRIC	1
6	5328	09-009071-11	SCREW	2
7	204868	09-009602-42	SPACER	1
8	2902	09-009053-42	SCREW	1
9	202286	09-009051-75	SPRING WASHER	1
10	5002	09-009053-54	SCREW	1
11	3044	09-009053-49	NUT	1
12	210007	09-009613-06	FEED BAR COVER	1
13	2905	09-009823-33	SCREW	2
14	208604	09-009607-98	OIL SHIELD COMPLETE	1
15	5147	09-009053-96	SCREW	1
16	208001-FD	09-009070-83	FRONT COVER (RIGHT)	1
17	1175-3	09-009048-14	SCREW	2
18	200821	09-009048-98	WASHER	2
19	208008-FD	09-009604-64	HINGE/FRONT COVER	1
20	1216	09-009048-20	SCREW	3
21	208009	09-009070-87	PIN	1
22	200555	09-009071-03	RING	1
23	5146	09-009053-95	SCREW	2
24	208010	09-009070-88	SPRING	1
25	5094	09-009053-82	SCREW	1
26	5137	09-009053-91	NUT	1
27	208401	09-009070-84	FRONT COVER (LEFT)	1
28	208003	09-009070-85	FRONT COVER (LEFT)	1
29	208004	09-009833-49	FRONT COVER (LEFT)	1
30	208005	09-009600-44	FRONT COVER (LEFT)	1
31	208006	09-009833-50	FRONT COVER (LEFT)	1
32	208058	09-009600-45	FRONT COVER (LEFT)	1
33	208056	09-009833-51	FRONT COVER (LEFT)	1
34	209285	09-009821-54	FRONT COVER (LEFT)	1

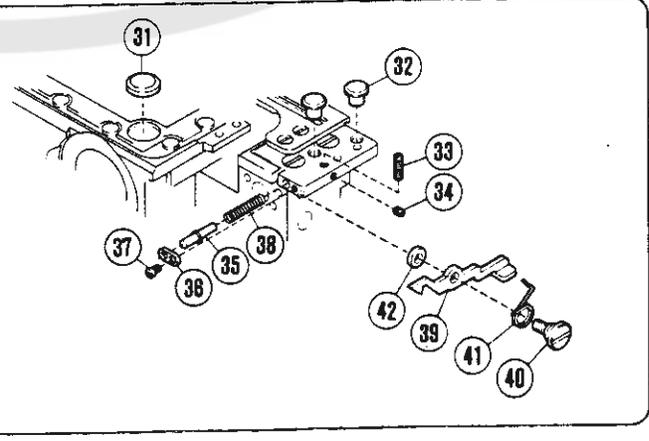
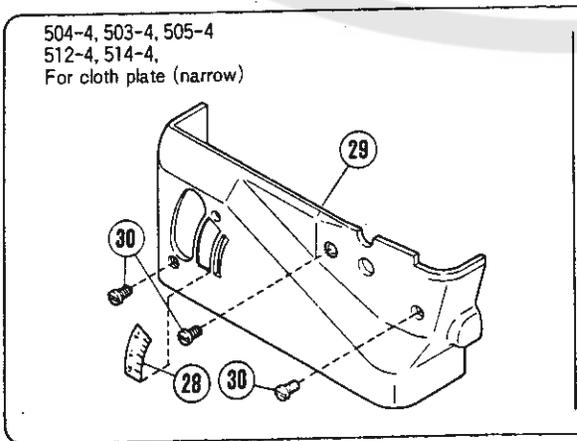
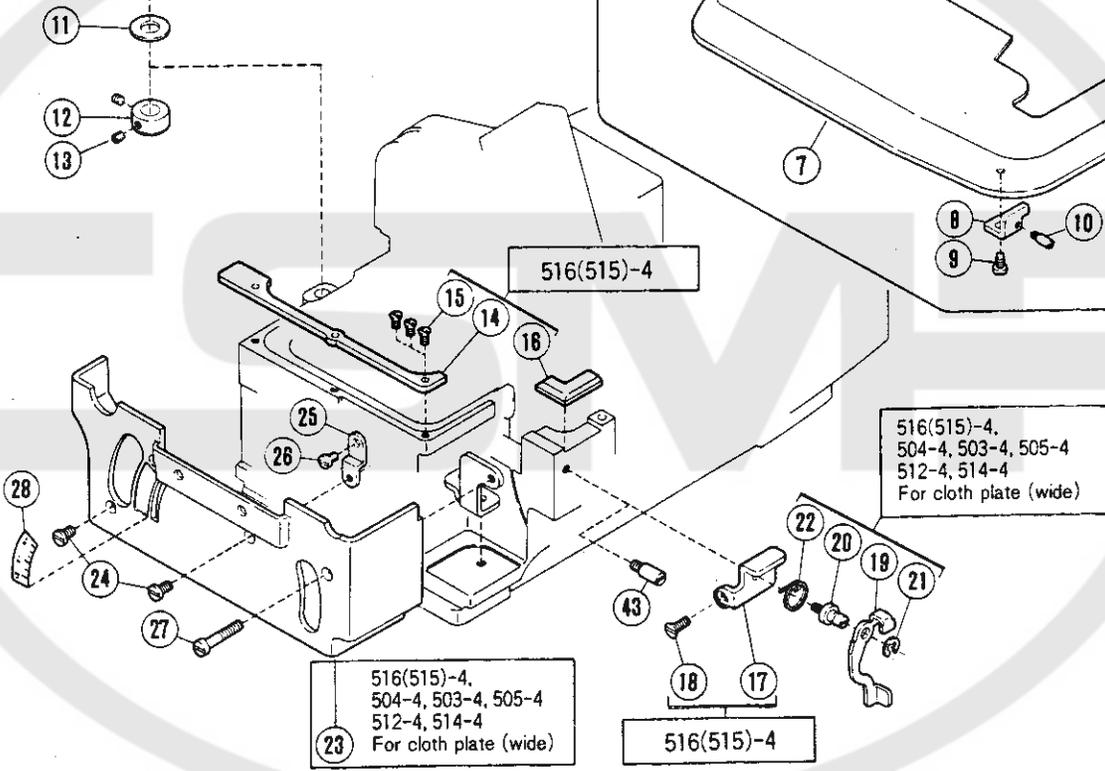
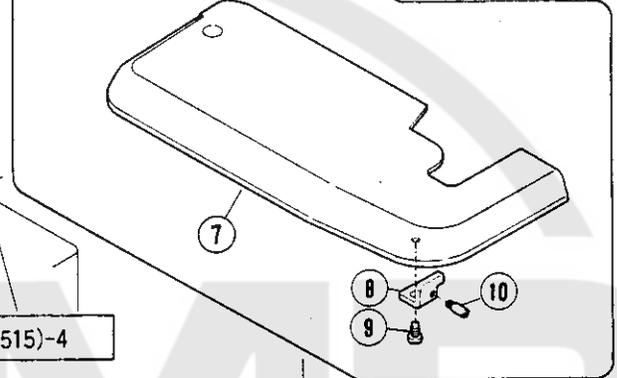
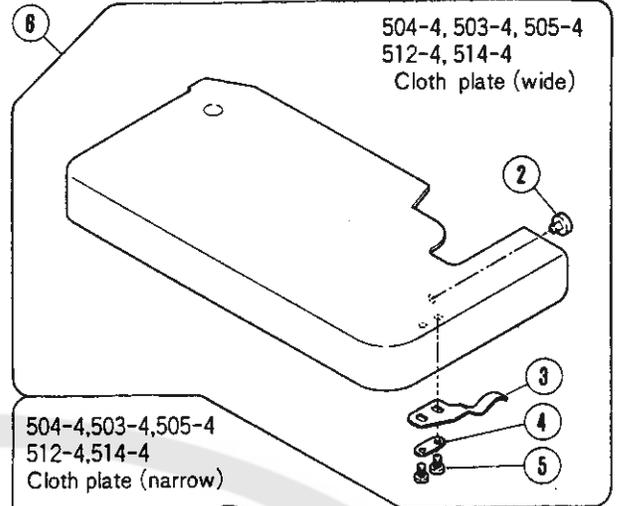
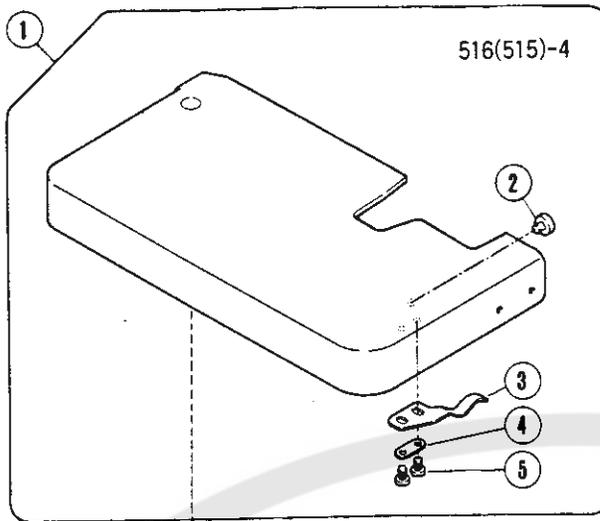

COVER (3)

REF. NO.	PART NO.	PFAFF-NO.	NAME	QT.
1	208610	09-009605-04	CLOTH PLATE COMPLETE	1
2	210025	09-009613-16	CUSHION	1
3	204218	09-009064-49	FLAT SPRING	1
4	200162A	09-009815-02	WASHER	1
5	1216	09-009048-20	SCREW	2
6	208612	09-009600-30	CLOTH PLATE COMPLETE	1
7	208611	09-009600-27	CLOTH PLATE COMPLETE	1
8	204744	09-009068-32	BRACKET	1
9	1202	09-009048-17	SCREW	1
10	204743	09-009068-31	SCREW	1
11	202576	09-009052-60	WASHER	1
12	201139	09-009050-16	COLLAR	1
13	1457	09-009048-64	SCREW	2
14	204242	09-009064-63	RUBBER PLUG	1
15	5022	09-009068-68	SCREW	3
16	204243	09-009064-64	RUBBER PLUG	1
17	208741	09-009833-69	STOPPER	1
18	1732	09-009048-67	SCREW	1
19	208737	09-009833-66	LEVER	1
20	208738	09-009833-67	PIN	1
21	201629	12-610150-45	RING	1
22	208740	09-009833-68	SPRING	1
23	204865A-FA	09-009602-32	SIDE COVER (WIDE)	1
24	5091	09-009067-20	SCREW	2
25	204867	09-009600-54	SPACER	1
26	5113	09-009054-70	SCREW	1
27	5182	09-009601-03	SCREW	1
28	209405	09-009840-01	INDICATION PLATE	1
29	204857A-FA	09-009833-43	SIDE COVER	1
30	5091	09-009067-20	SCREW	3
31	204827	09-009602-25	RUBBER PLUG	1
32	204749	09-009067-83	RUBBER PLUG	2
33	1435	09-009048-63	SCREW	1
34	1459	09-009053-73	SCREW	1
35	204746	09-009600-28	PIN	1
36	204747	09-009068-34	GUIDE	1
37	5053	09-009053-62	SCREW	1
38	204748	09-009068-35	SPRING	1
39	204742	09-009068-29	LATCH	1
40	5362	09-009068-30	SCREW	1
41	204745	09-009068-33	SPRING	1
42	208245	09-009612-96	WASHER	1
43	5232	09-009064-50	SCREW	1

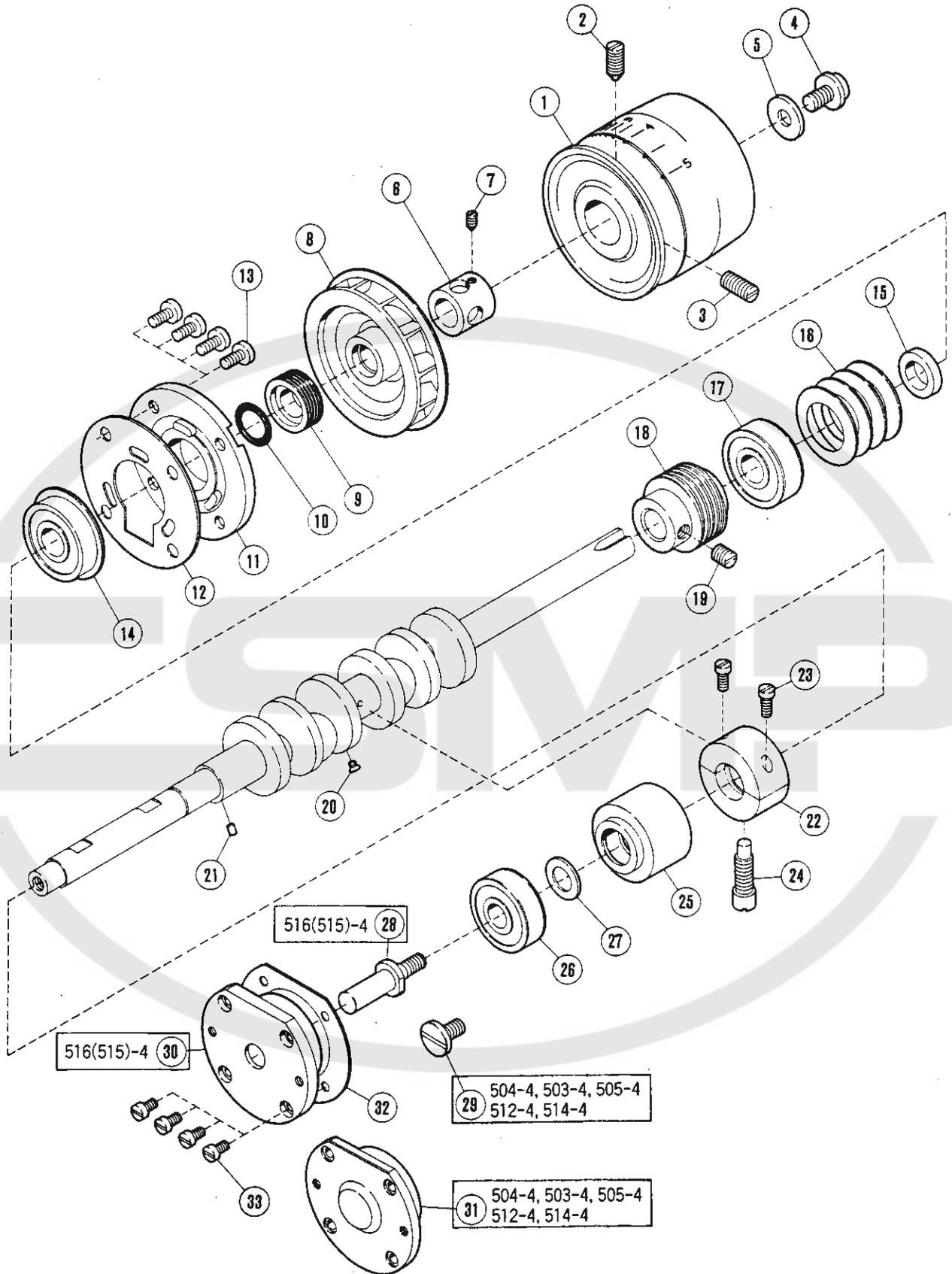

CRANKSHAFT DRIVE MECHANISM (1)

REF. NO.	PART NO.	PFAFF-NO.	NAME	QT.
1	208932-HD	09-009833-73	MACHINE PULLEY	1
2	5080	09-009053-71	SCREW	1
3	5081	09-009053-72	SCREW	1
4	5549	09-009816-63	SCREW	1
5	204023	09-009055-16	WASHER	1
6	204026	09-009067-51	SPACER	1
7	5267	09-009601-07	SCREW	1
8	204198	09-009602-06	COOLING FAN	1
9	208476	09-009800-13	OIL SEAL COLLAR	1
10	208272	09-009069-89	O RING	1
11	208477	09-009800-14	PLATE	1
12	204022	09-009055-13	GASKET	1
13	5117	09-009053-88	SCREW	4
14	204020A	09-009055-11	BUSHING	1
15	204019A	09-009055-10	SPACER	1
16	204018	09-009055-09	SPRING	4
17	201523A	09-009055-08	BALL BEARING	1
18	204186A	09-009833-40	WORM	1
19	2022	09-009051-60	SCREW	1
20	5304	09-009618-25	SCREW	1
21	207358	09-400144-00	OIL FELT	1
22	204016	09-009067-43	BUSHING	1
23	1170-1	09-009048-12	SCREW	2
24	5240	09-009067-45	SCREW	1
25	204014	09-009064-95	BUSHING	1
26	204010	14-018570-01	BUSHING	1
27	240102	09-400167-00	WASHER	1
28	204873	09-009605-33	CRANK SHAFT EXTENSION	1
29	5361	09-009067-79	SCREW	1
30	204881	09-009605-31	HOUSING	1
31	204737	09-009067-81	HOUSING	1
32	204319	09-009065-97	GASKET	1
33	1175-2	09-009048-13	SCREW	4

①	③ ~ ⑬	516(515)-4 except the following models.
②	③ ~ ⑮ • ⑰	516(515)-4/86, 87, 88, 89, 355, 359, 555, 559

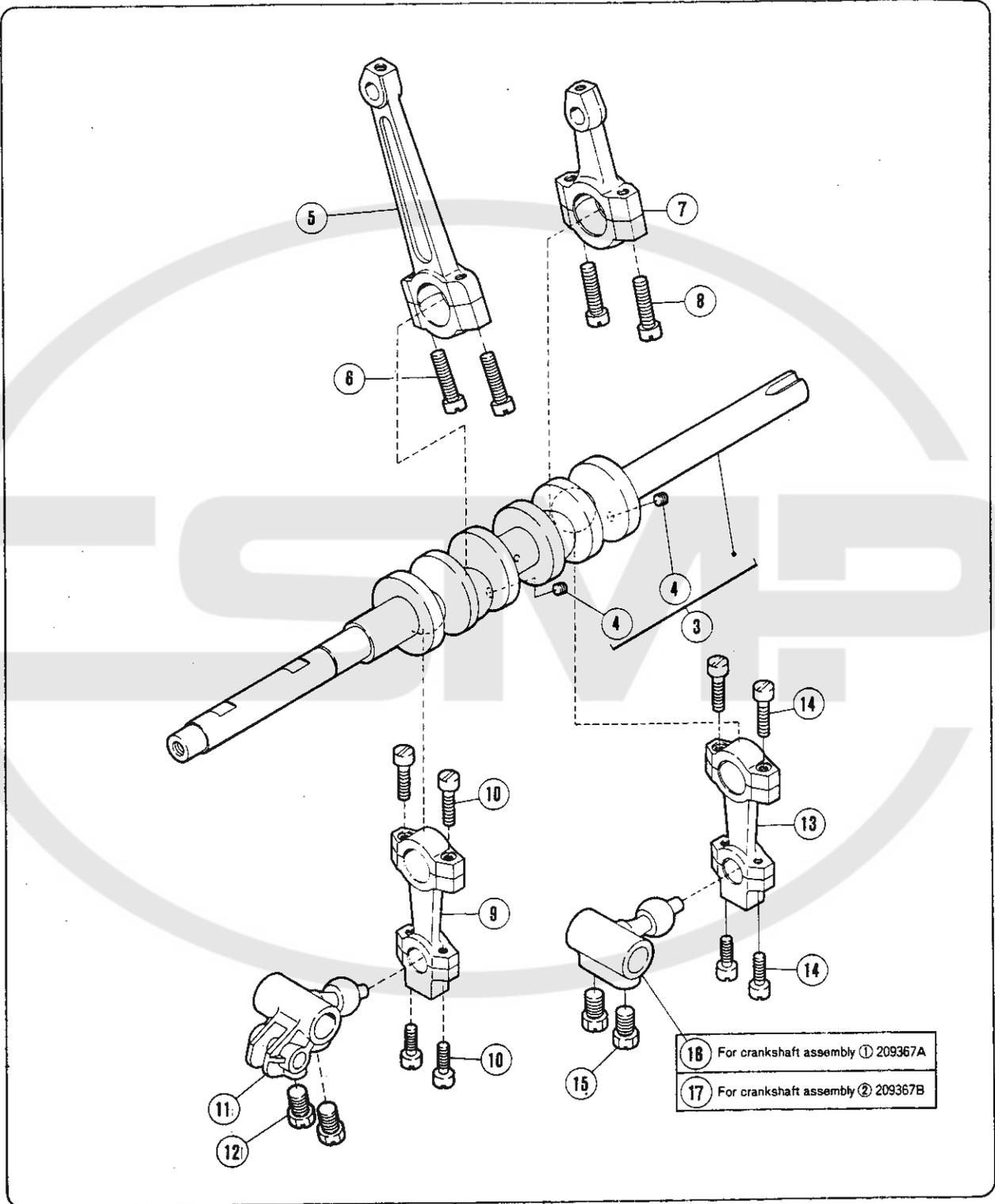

CRANKSHAFT DRIVE MECHANISM (2)

REF. NO.	PART NO.	PFAFF-NO.	NAME	QT.
1	209367A	09-009839-93	CRANKSHAFT ASSEMBLY	1
2	209367B	09-009839-94	CRANKSHAFT ASSEMBLY	1
3	208951	09-009833-76	CRANKSHAFT	1
4	1459	09-009053-73	SCREW	2
5	204029	09-009055-17	CONNECTION	1
6	5233	09-009065-82	SCREW	2
7	204145A	09-009065-70	DRIVE CONNECTION/UPPER KNIFE	1
8	5233	09-009065-82	SCREW	2
9	208346	09-009607-25	CONNECTION	1
10	5376	09-009612-37	SCREW	4
11	208192	09-009605-97	CRANK/LOWER LOOPER	1
12	2022-4	09-009051-78	SCREW	2
13	208346	09-009607-25	CONNECTION	1
14	5376	09-009612-37	SCREW	4
15	2022-4	09-009051-78	SCREW	2
16	204048A	09-009055-28	CRANK	1
17	204788	09-009602-21	CRANK/LOWER LOOPER	1



1	4	~	16	•	18		
2	4	~	15	•	17	•	18
3	4	~	15	•	17	•	19

- ① • 504-4,503-4,505-4(except 504-4/65)
- ② • 514-4,512-4(except 514-4/18,18S1,18S2,18S4,18S5
514-4/67,73.)
• 504-4/65(SW=3.0~6.0mm)
- ③ • 514-4/18, 18S1, 18S2, 18S4, 18S5
514-4/67, 73
• 504-4/65(SW=7.0~8.0mm)

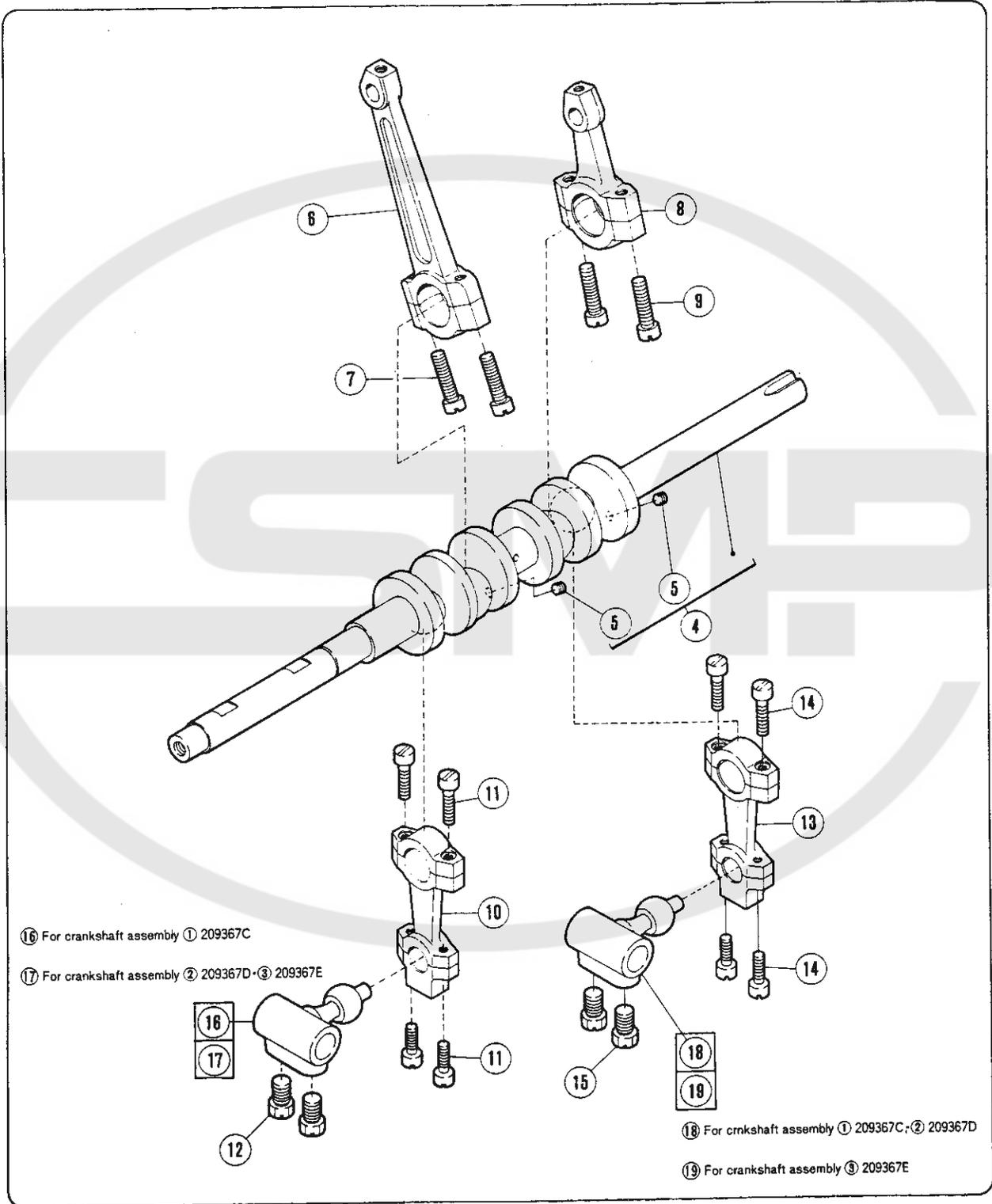

CRANKSHAFT DRIVE MECHANISM (3)

REF. NO.	PART NO.	PFAFF-NO.	NAME	QT.
1	209367C	09-009839-95	CRANKSHAFT ASSEMBLY	1
2	209367D	09-009839-96	CRANKSHAFT ASSEMBLY	1
3	209367E	09-009839-97	CRANKSHAFT ASSEMBLY	1
4	208951	09-009833-76	CRANKSHAFT	1
5	1459	09-009053-73	SCREW	2
6	204029	09-009055-17	CONNECTION	1
7	5233	09-009065-82	SCREW	2
8	204145A	09-009065-70	DRIVE CONNECTION/UPPER KNIFE	1
9	5233	09-009065-82	SCREW	2
10	208346	09-009607-25	CONNECTION	1
11	5376	09-009612-37	SCREW	4
12	2022-4	09-009051-78	SCREW	2
13	208346	09-009607-25	CONNECTION	1
14	5376	09-009612-37	SCREW	4
15	2022-4	09-009051-78	SCREW	2
16	204787	09-009601-24	CRANK/LOWER LOOPER	1
17	204788	09-009602-21	CRANK/LOWER LOOPER	1
18	204048A	09-009055-28	CRANK	1
19	204788	09-009602-21	CRANK/LOWER LOOPER	1

CSMP

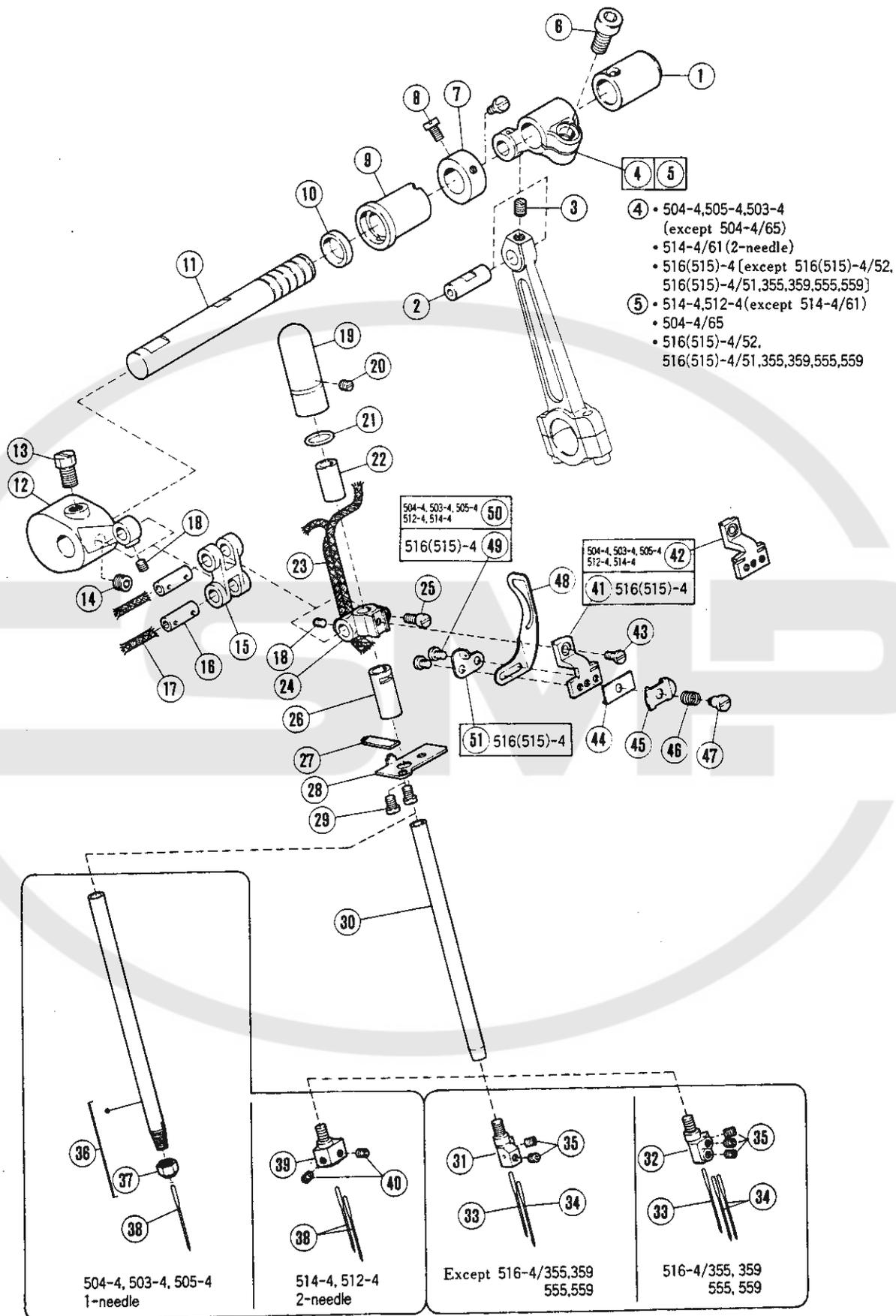

NEEDLE DRIVE MECHANISM (1)

PLEASE NOTE :「XXXXXX」 is one of the gauge parts.
So please refer to pages 74~132 and
confirm the correct parts.

REF. NO.	PART NO.	PFAFF-NO.	NAME	QT.
1	208249	09-009605-47	BUSHING	1
2	205495-2	09-009603-81	PIN	1
3	5234	09-009065-83	SCREW	1
4	201360B	09-009051-43	CRANK	1
5	201441B	09-009068-03	CRANK	1
6	5381	09-009069-26	SCREW	1
7	201117	09-009050-05	COLLAR	1
8	5328	09-009071-11	SCREW	2
9	208248	09-009605-46	BUSHING	1
10	208250	09-009605-48	OIL SEAL	1
11	208247	09-009605-45	SHAFT	1
12	208424	09-009607-51	CRANK/NEEDLE BAR	1
13	2022-4	09-009051-78	SCREW	1
14	5312	09-009601-14	SCREW	1
15	208425	09-009607-52	LINK/NEEDLE BAR DRIVE	1
16	200654	09-009601-57	PIN	2
17	202176	26-536302-09	OIL WICK	2
18	5292	09-009064-89	SCREW	2
19	208621	09-009608-84	CAP	1
20	1457	09-009048-64	SCREW	1
21	200030	09-009601-54	O RING	1
22	204625A	09-009067-90	BUSHING	1
23	212186	09-009734-34	OIL WICK	1
24	208427	09-009607-53	NEEDLE BAR CLAMP	1
25	1170-3	09-009054-62	SCREW	1
26	204627A	09-009067-92	BUSHING	1
27	208617	09-009608-83	OIL FELT	1
28	208616	09-009605-57	DUST SHIELD	1
29	5053	09-009053-62	SCREW	2
30	208903	09-009812-05	NEEDLE BAR	1
31	XXXXXX		NEEDLE HOLDER	1
32	XXXXXX		NEEDLE HOLDER	1
33	XXXXXX		NEEDLE HOLDER	1
34	XXXXXX		NEEDLE HOLDER	1
35	5292	09-009064-89	SCREW	1
36	204623	09-009067-88	NEEDLE BAR COMPLETE	1
37	3119	09-009053-51	NUT	1
38	XXXXXX		NEEDLE	1
39	XXXXXX		NEEDLE HOLDER	1
40	5292	09-009064-89	SCREW	2
41	204706	09-009605-37	RETAINER BRACKET	1
42	202705A	09-009055-02	RETAINER BRACKET	1
43	5359	09-009054-05	SCREW	1
44	202495	09-009070-14	GUIDE	1
45	200041	09-009054-85	GUIDE	1
46	209068	09-009800-43	SPRING	1
47	W09070-2	09-009054-35	SCREW	1
48	202706A	09-009055-03	THREAD TAKEUP	1
49	1186	09-009048-15	SCREW	2
50	5292	09-009064-89	SCREW	2
51	204707	09-009605-59	THREAD GUIDE	1

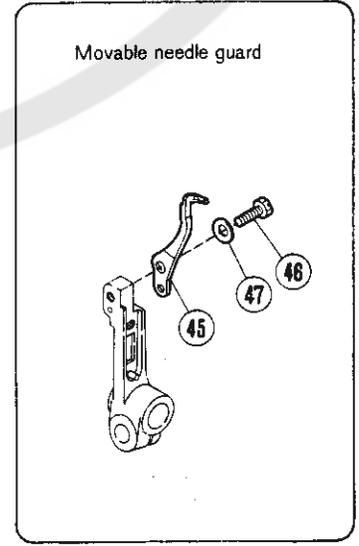
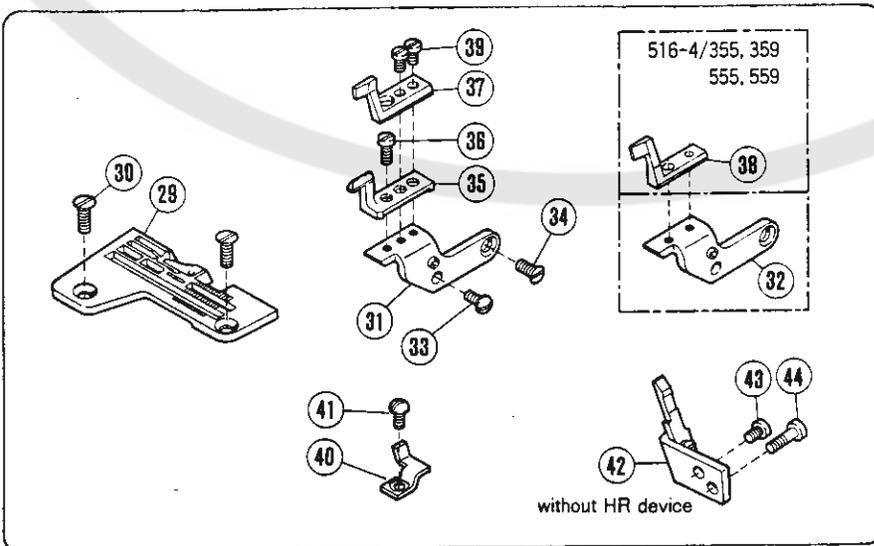
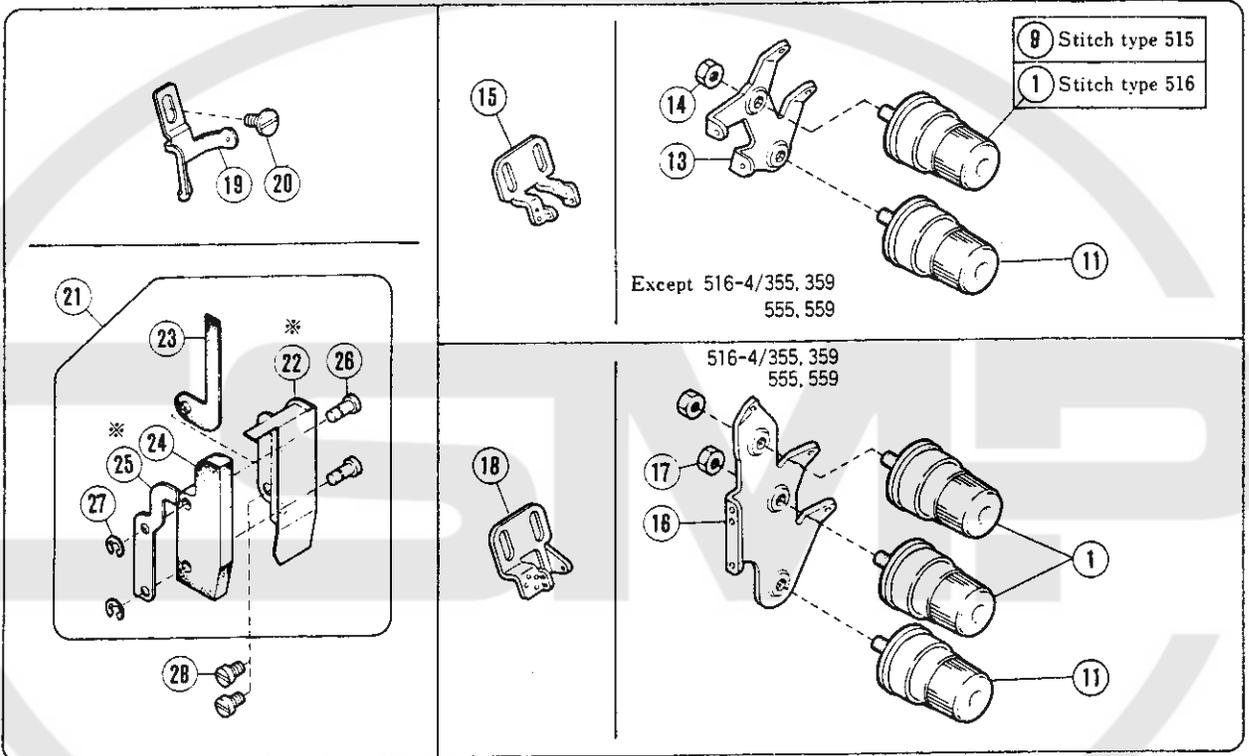
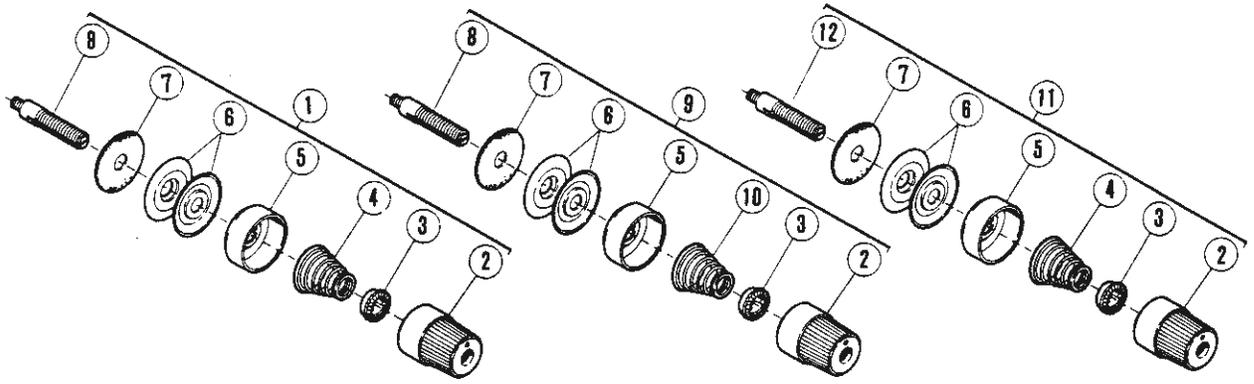

NEEDLE DRIVE MECHANISM (2)

PLEASE NOTE :「XXXXXX」 is one of the gauge parts.
So please refer to pages 74~132 and
confirm the correct parts.

REF. NO.	PART NO.	PFAFF-NO.	NAME	QT.
1	209174	09-009800-50	THREAD TENSION COMPLETE	1
2	208447	09-009813-81	POST NUT	1
3	208448	09-009607-59	SPRING BUSHING	1
4	201037	09-009049-22	SPRING (HEAVY)	1
5	208450	09-009813-82	CUP	1
6	210319	09-009615-68	TENSION DISC	2
7	208449	09-009607-60	FELT	1
8	5143A	09-009600-25	STUD	1
9	209175	09-009800-51	THREAD TENSION COMPLETE	1
10	201068	09-009049-44	SPRING (LIGHT)	1
11	210529	09-009617-17	THREAD TENSION COMPLETE	1
12	5082A	09-009053-74	SCREW STUD	1
13	208307	09-009607-09	TENSION GUIDE	1
14	5137	09-009053-91	NUT	1
15	208778	09-009064-70	THREAD GUIDE	1
16	209161	09-009800-46	TENSION GUIDE	1
17	5137	09-009053-91	NUT	2
18	208777	09-009066-27	THREAD GUIDE	1
19	208399	09-009605-60	THREAD GUIDE	1
20	4009-1	09-009053-53	SCREW	1
21	208568	09-009607-91	NEEDLE BAR LINK COVER COMPLETE	1
*22	208560	09-009840-60	NEEDLE BAR LINK COVER	1
23	208561	09-009607-88	OIL FELT	1
24	208562	09-009607-89	OIL FELT	1
*25	208563	09-009840-61	OIL FELT PLATE	1
26	208713	09-009800-20	PIN	2
27	200555	09-009071-03	RING	2
28	5113	09-009054-70	SCREW	2
29	XXXXXX		NEEDLE PLATE	1
30	1732-HC	09-009833-35	SCREW	2
31	204783	09-009069-30	BRACKET	1
32	209160	09-009800-45	BRACKET/NEEDLE GUARD	1
33	5227	09-009068-73	SCREW	1
34	5107	09-009605-41	SCREW	1
35	204781	09-009069-28	NEEDLE GUARD (REAR)	1
36	5012	09-009065-32	SCREW	1
37	204782	09-009069-29	NEEDLE GUARD (FRONT)	1
38	209159	09-009800-44	NEEDLE GUARD (FRONT)	1
39	5029	09-009053-59	SCREW	2
40	XXXXXX		NEEDLE GUARD	1
41	5227	09-009068-73	SCREW	1
42	XXXXXX		NEEDLE GUARD	1
43	1206	09-009048-19	SCREW	1
44	5010	09-009053-55	SCREW	1
45	209009	09-009800-42	MOVABLE NEEDLE GUARD	1
46	5501	09-009618-31	SCREW	1
47	210930	09-009618-32	SPRING WASHER	1

Notice) Parts with mark * are not for sale.

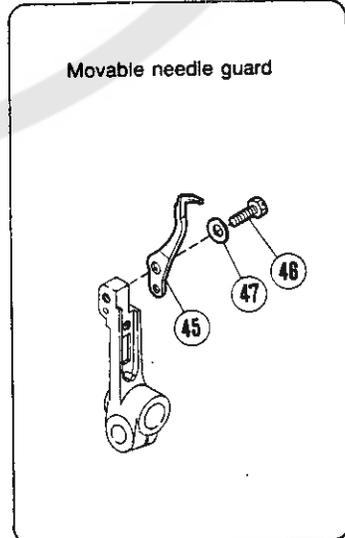
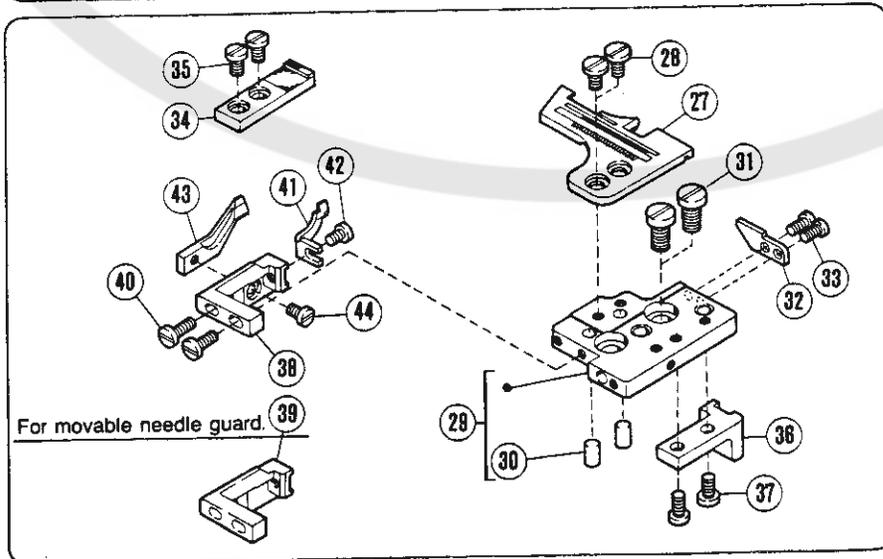
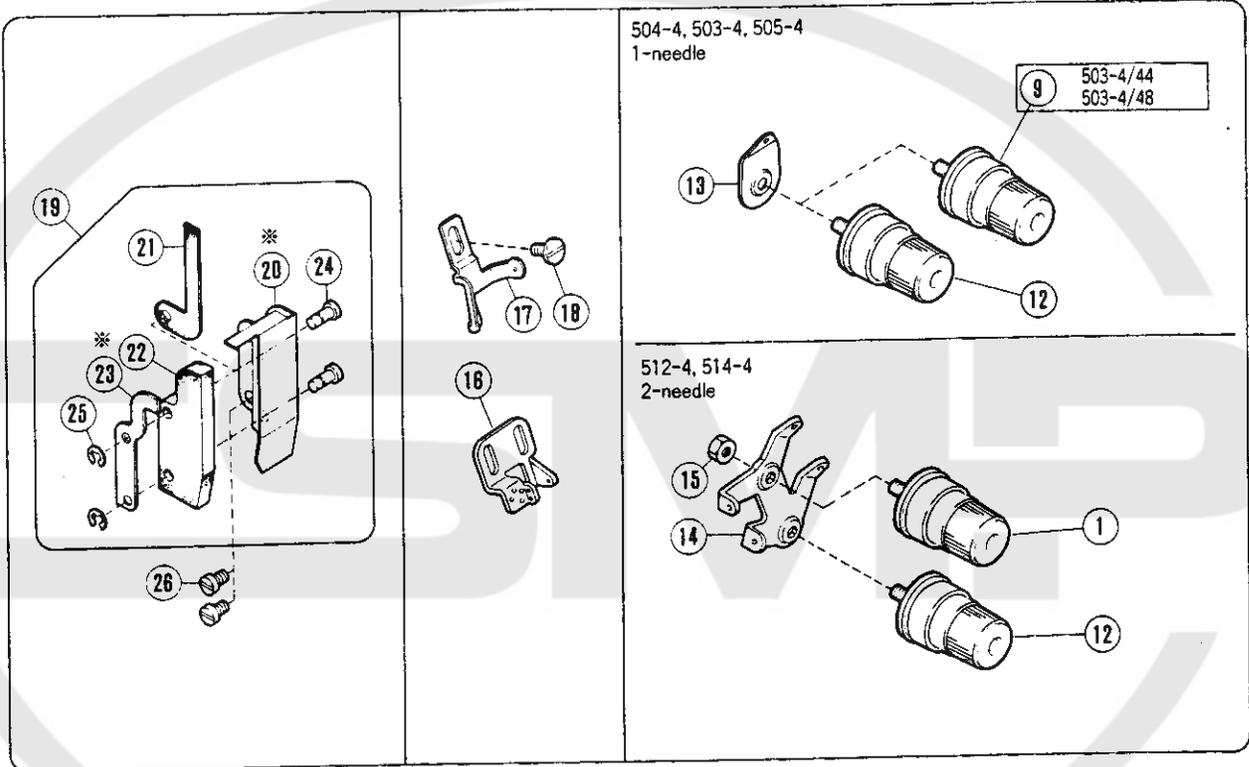
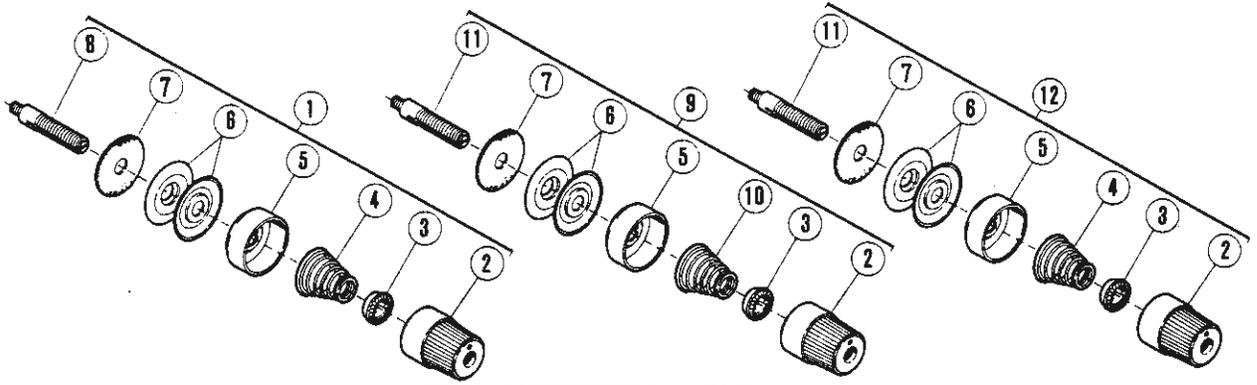

NEEDLE DRIVE MECHANISM(3)

PLEASE NOTE :「XXXXXX」 is one of the gauge parts.
So please refer to pages 74~132 and
confirm the correct parts.

REF. NO.	PART NO.	PFAFF-NO.	NAME	QT.
1	209174	09-009800-50	THREAD TENSION COMPLETE	1
2	208447	09-009813-81	POST NUT	1
3	208448	09-009607-59	SPRING BUSHING	1
4	201037	09-009049-22	SPRING (HEAVY)	1
5	208450	09-009813-82	CUP	1
6	210319	09-009615-68	TENSION DISC	2
7	208449	09-009607-60	FELT	1
8	5143A	09-009600-25	STUD	1
9	210531	09-009617-19	THREAD TENSION COMPLETE	1
10	201068	09-009049-44	SPRING (LIGHT)	1
11	5082A	09-009053-74	SCREW STUD	1
12	210529	09-009617-17	THREAD TENSION COMPLETE	1
13	202849	09-009055-24	TENSION GUIDE	1
14	208307	09-009607-09	TENSION GUIDE	1
15	5137	09-009053-91	NUT	1
16	208777	09-009066-27	THREAD GUIDE	1
17	208400	09-009600-65	THREAD GUIDE	1
18	4009-1	09-009053-53	SCREW	1
19	208568	09-009607-91	NEEDLE BAR LINK COVER COMPLETE	1
*20	208560	09-009840-60	NEEDLE BAR LINK COVER	1
21	208561	09-009607-88	OIL FELT	1
22	208562	09-009607-89	OIL FELT	1
*23	208563	09-009840-61	OIL FELT PLATE	1
24	208713	09-009800-20	PIN	2
25	200555	09-009071-03	RING	2
26	5113	09-009054-70	SCREW	2
27	XXXXXX		NEEDLE PLATE	1
28	4009-1HC	09-009833-37	SCREW	2
29	204750	09-009067-94	BRACKET/NEEDLE PLATE	1
30	204630	09-009600-94	PIN	2
31	5357	09-009067-95	SCREW	2
32	204631	09-009067-96	KEY	1
33	5142	09-009053-94	SCREW	1
34	208935	09-009833-74	SUPPORT/NEEDLE PLATE	1
35	5091	09-009067-20	SCREW	1
36	204762	09-009600-68	BASE/EDGE GUIDE	1
37	5091	09-009067-20	SCREW	2
38	204636	09-009068-02	BRACKET/NEEDLE DUARD	1
39	204636A	09-009833-42	BRACKET/NEEDLE DUARD	1
40	1175-3	09-009048-14	SCREW	2
41	XXXXXX		NEEDLE GUARD (FRONT)	1
42	1206	09-009048-19	SCREW	1
43	XXXXXX		NEEDLE GUARD (REAR)	1
44	1206	09-009048-19	SCREW	1
45	209009	09-009800-42	MOVABLE NEEDLE GUARD	1
46	5501	09-009618-31	SCREW	1
47	210930	09-009618-32	SPRING WASHER	1

Notice) Parts with mark * are not for sale.

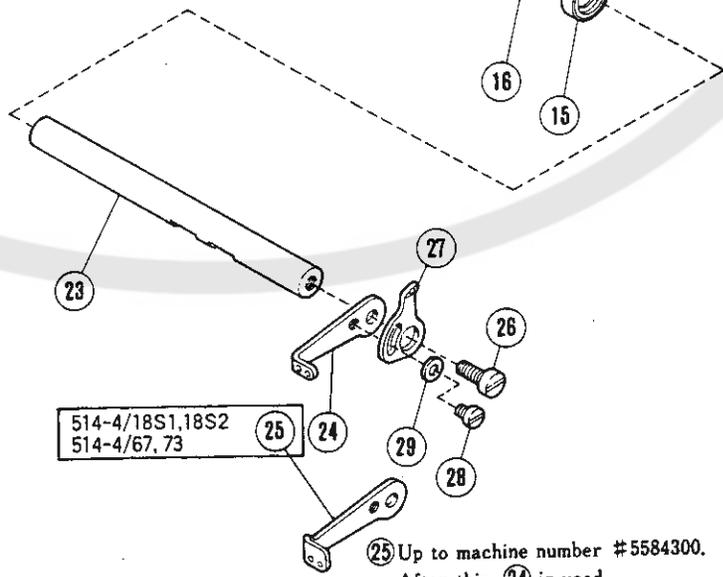
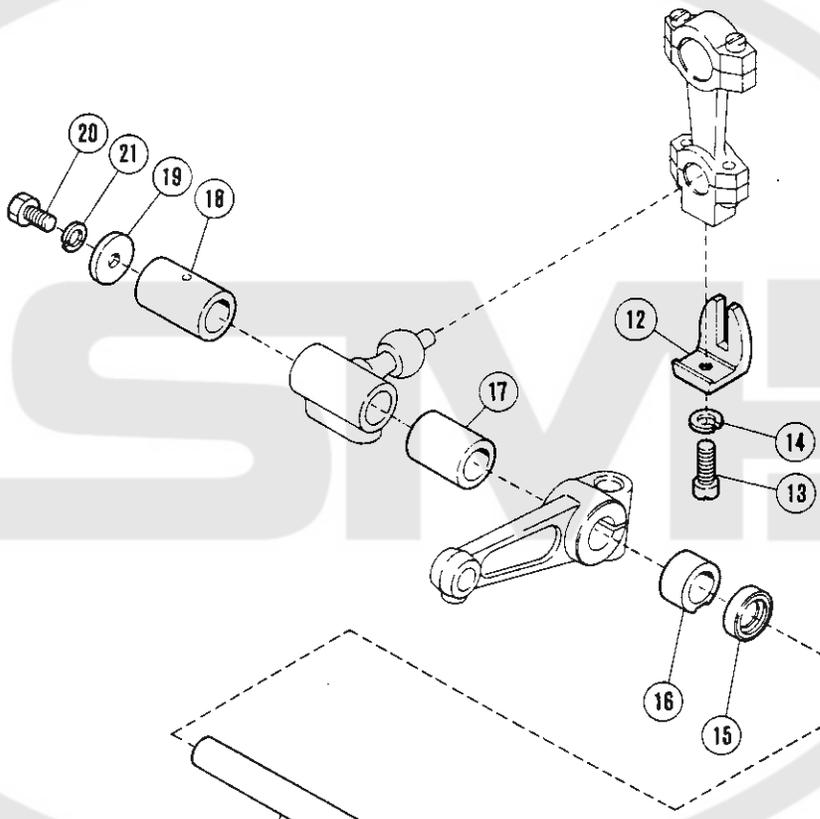
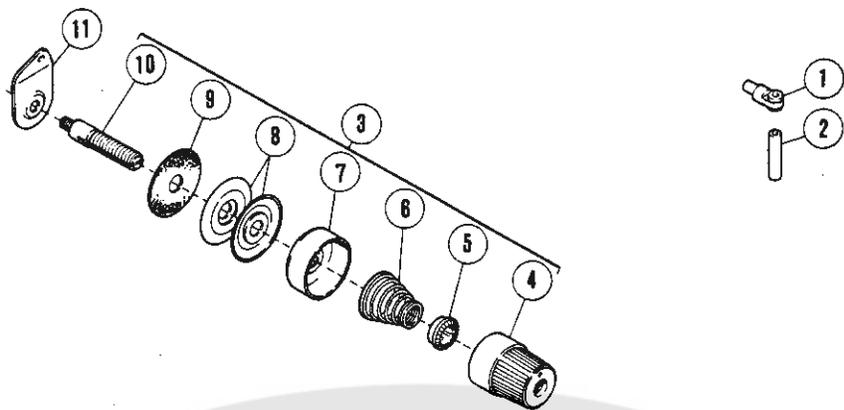

514-4/18S1,18S2
514-4/67, 73

25 Up to machine number #5584300.
After this, 24 is used.

UPPER LOOPER DRIVE MECHANISM (1)

REF. NO.	PART NO.	PFAFF-NO.	NAME	QT.
1	201048A	09-009049-29	THREAD EYELET	1
2	201072A	09-009068-93	PIPE	1
3	210531	09-009617-19	THREAD TENSION COMPLETE	1
4	208447	09-009813-81	POST NUT	1
5	208448	09-009607-59	SPRING BUSHING	1
6	201068	09-009049-44	SPRING (LIGHT)	1
7	208450	09-009813-82	CUP	1
8	210319	09-009615-68	TENSION DISC	2
9	208449	09-009607-60	FELT	1
10	5082A	09-009053-74	SCREW STUD	1
11	202849	09-009055-24	TENSION GUIDE	1
12	201074A	09-009049-48	GUIDE	1
13	5546	09-009732-64	SCREW	1
14	202286	09-009051-75	SPRING WASHER	1
15	204052A	09-009064-62	OIL SEAL	1
16	208292	09-009605-76	BUSHING	1
17	210297	09-009615-49	BUSHING	1
18	208429	09-009607-54	BUSHING (REAR)	1
19	204107	09-009067-58	WASHER	1
20	2193	09-009053-37	SCREW	1
21	202286	09-009051-75	SPRING WASHER	1
22				
23	210281	09-009615-35	SHAFT/LOWER LOOPER	1
24	208445	09-009607-57	THREAD TAKEUP/UPPER LOOPER	1
25	208979	09-009833-77	THREAD TAKEUP/UPPER LOOPER	1
26	2902	09-009053-42	SCREW	1
27	204902	09-009603-16	AUXILIARY THREAD TAKEUP	1
28	2921	09-009053-46	SCREW	1
29	202875	09-009601-76	WASHER	1

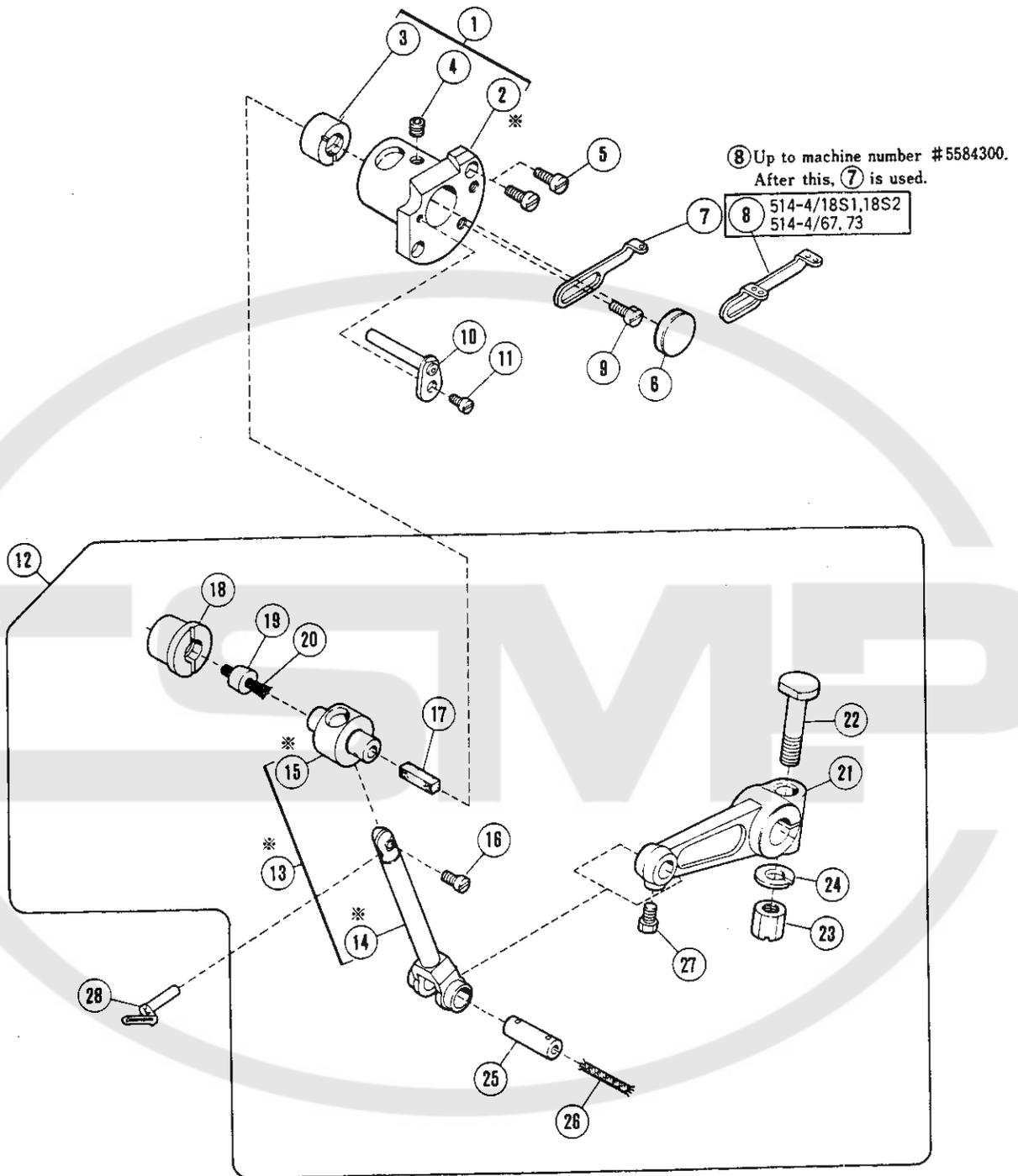

UPPER LOOPER DRIVE MECHANISM (2)

PLEASE NOTE : 「XXXXXX」 is one of the gauge parts.
So please refer to pages 74~132 and
confirm the correct parts.

REF. NO.	PART NO.	PFAFF-NO.	NAME	QT.
1	209250	09-009800-53	HOUSING ASSEMBLY	1
* 2	208937	09-009800-35	HOUSING	1
3	210109	09-009613-88	BUSHING	1
4	5408	09-009070-03	SCREW	1
5	1175-2	09-009048-13	SCREW	2
6	208173	09-009604-72	PLUG	1
7	204905	09-009603-17	THREAD GUIDE	1
8	208980	09-009833-78	THREAD GUIDE (LOWER)	1
9	2905	09-009823-33	SCREW	1
10	204903	09-009068-11	THREAD TUBE	1
11	5012	09-009065-32	SCREW	1
12	209389-91Y	09-009607-17	UPPER LOOPER HOLDER	1
*13	208976	09-009840-62	UPPER LOOPER HOLDER ASSEMBLY	1
*14	208974	09-009800-38	UPPER LOOPER HOLDER	1
*15	210107	09-009613-86	GUIDE/UPPER LOOPER HOLDER	1
16	1998-2	09-009048-69	SCREW	1
17	204274	09-009064-69	OIL WICK	2
18	208938	09-009800-36	BUSHING (REAR)	1
19	208592	09-009607-92	CAP	1
20	202176	26-536302-09	OIL WICK	1
21	204055B	09-009055-33	CRANK/UPPER LOOPER	1
22	5239	09-009054-78	SCREW	1
23	5286	09-009054-01	NUT	1
24	202045	12-500190-45	SPRING WASHER	1
25	208258-2	09-009605-49	PIN	1
26	202176	26-536302-09	OIL WICK	1
27	5084	09-009053-76	SCREW	1
28	XXXXXX		UPPER LOOPER	1

Notice) Parts with mark * are not for sale.

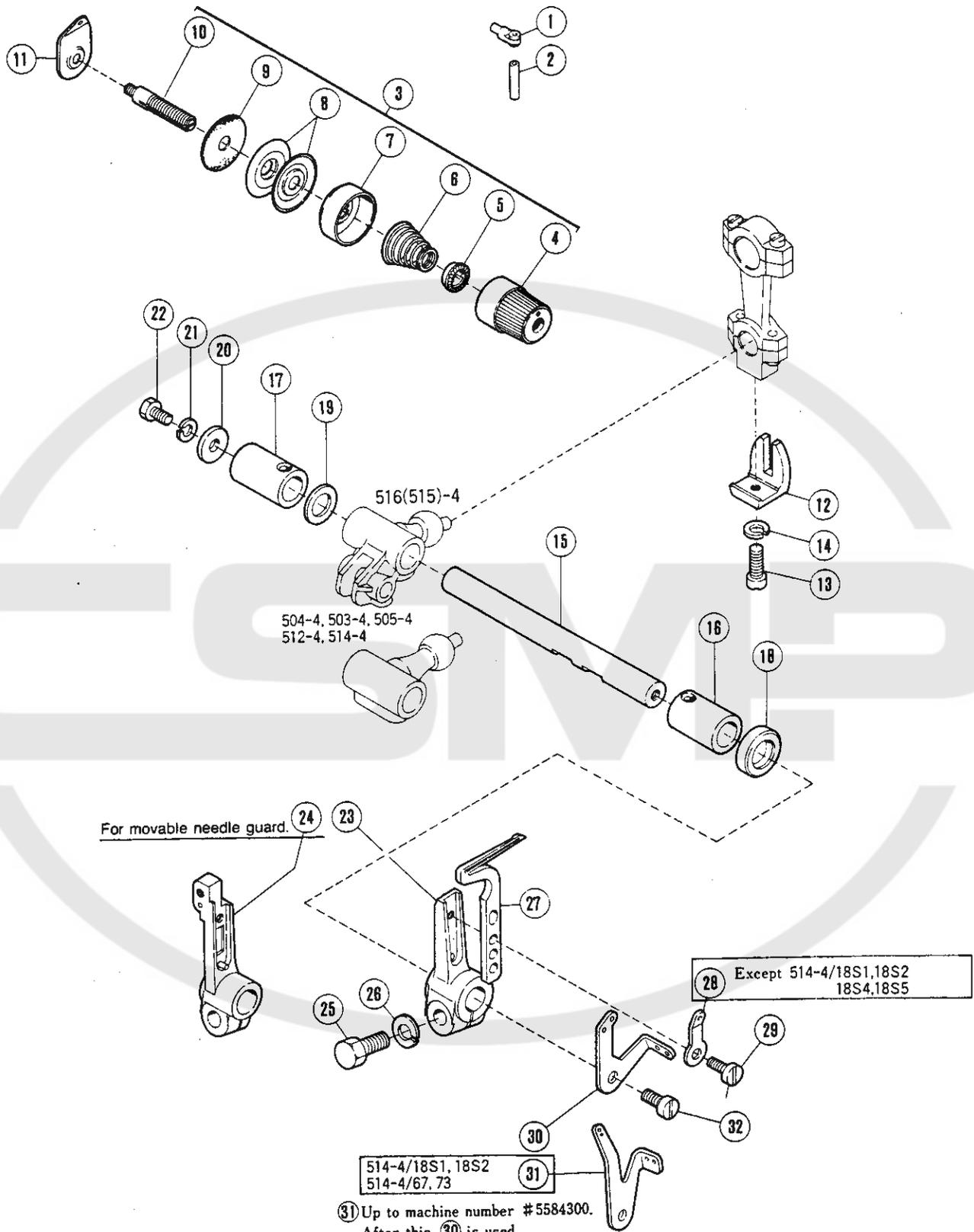

LOWER LOOPER DRIVE MECHANISM

PLEASE NOTE : 「XXXXXX」 is one of the gauge parts.
So please refer to pages 74~132 and
confirm the correct parts.

REF. NO.	PART NO.	PFAFF-NO.	NAME	QT.
1	201048A	09-009049-29	THREAD EYELET	1
2	201072A	09-009068-93	PIPE	1
3	210530	09-009617-18	THREAD TENSION COMPLETE	1
4	208447	09-009813-81	POST NUT	1
5	208448	09-009607-59	SPRING BUSHING	1
6	201086	09-009049-57	SPRING (MEDIUM)	1
7	208450	09-009813-82	CUP	1
8	210319	09-009615-68	TENSION DISC	2
9	208449	09-009607-60	FELT	1
10	5082A	09-009053-74	SCREW STUD	1
11	202849	09-009055-24	TENSION GUIDE	1
12	201074A	09-009049-48	GUIDE	1
13	5546	09-009732-64	SCREW	1
14	202286	09-009051-75	SPRING WASHER	1
15	210281	09-009615-35	SHAFT/LOWER LOOPER	1
16	210124	09-009614-01	BUSHING	1
17	210125	09-009614-02	BUSHING	1
18	210586	09-009617-44	OIL SEAL	1
19	240102	09-400167-00	WASHER	1
20	204107	09-009067-58	WASHER	1
21	202286	09-009051-75	SPRING WASHER	1
22	2193	09-009053-37	SCREW	1
23	204664	09-009068-12	LOWER LOOPER HOLDER	1
24	209007	09-009800-41	LOWER LOOPER LEVER	1
25	5284	09-009067-39	SCREW	1
26	204293	09-009602-07	SPRING WASHER	1
27	XXXXXX		LOWER LOOPER	1
28	210353	09-009615-97	THREAD GUIDE	1
29	1175-3	09-009048-14	SCREW	1
30	204901	09-009070-79	THREAD TAKEUP	1
31	208981	09-009833-79	THREAD TAKEUP/LOWER LOOPER	1
32	2902	09-009053-42	SCREW	1

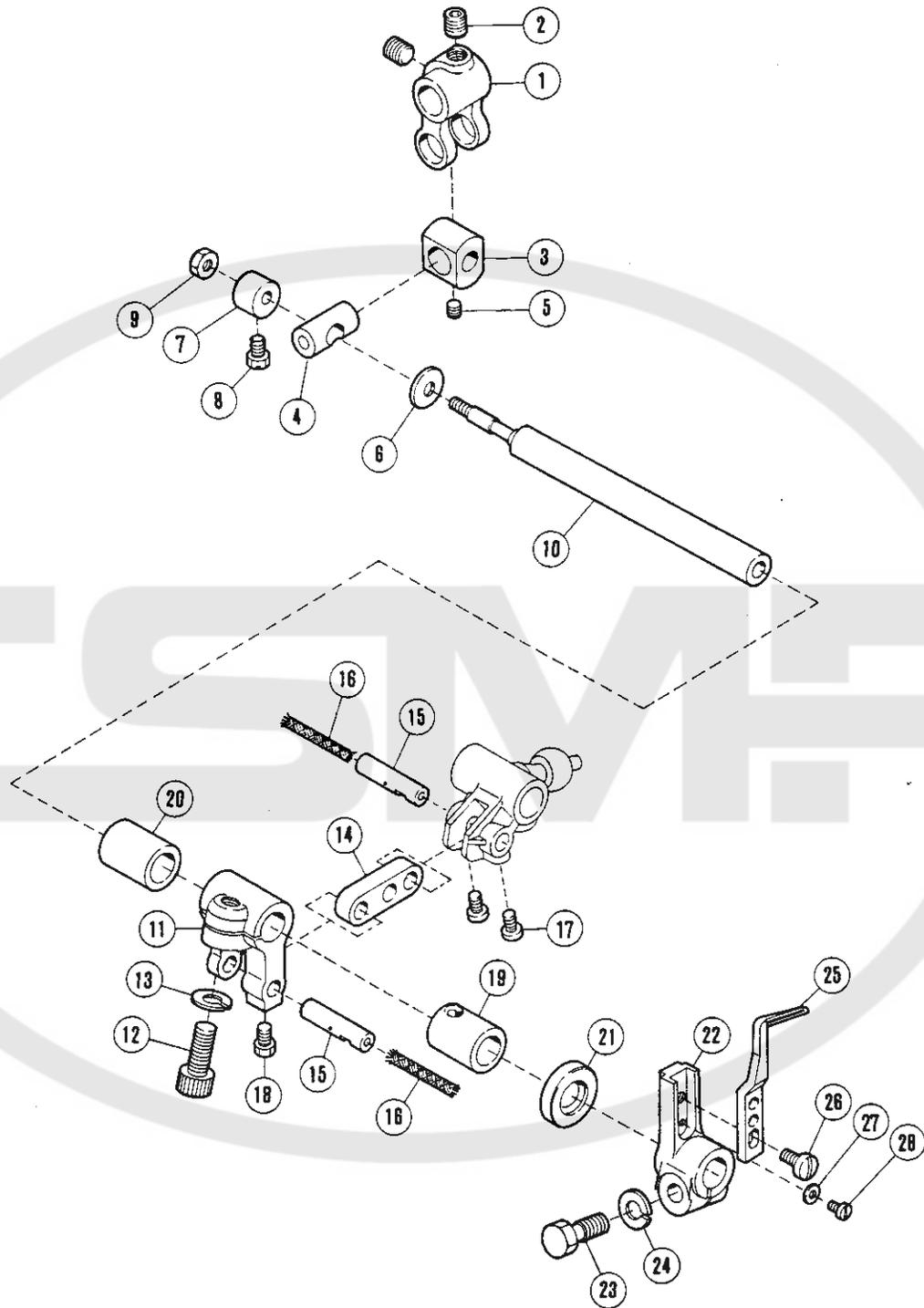

CHAINSTITCH LOOPER DRIVE MECHANISM (1)

PLEASE NOTE :「XXXXXX」 is one of the gauge parts.
So please refer to pages 74~132 and
confirm the correct parts.

REF. NO.	PART NO.	PFAFF-NO.	NAME	QT.
1	208025	09-009606-13	LINK/LOOPER AVOIDING	1
2	5385	09-009606-14	SCREW	2
3	208027	09-009606-16	BLOCK	1
4	208026	09-009606-15	PIN	1
5	5292	09-009064-89	SCREW	1
6	208028	09-009606-17	WASHER	1
7	208029	09-009606-18	COLLAR	1
8	5084	09-009053-76	SCREW	1
9	4802	09-400064-00	NUT	1
10	208196	09-009606-11	SHAFT/LOOPER DRIVE	1
11	210294	09-009615-47	CRANK/LOOPER DRIVE	1
12	5457	09-009612-42	SCREW	1
13	204293	09-009602-07	SPRING WASHER	1
14	208194	09-009606-08	LINK/LOOPER DRIVE	1
15	208195	09-009606-09	PIN	2
16	202176	26-536302-09	OIL WICK	2
17	5328	09-009071-11	SCREW	2
18	5084	09-009053-76	SCREW	1
19	210296	09-009615-48	BUSHING	1
20	210297	09-009615-49	BUSHING	1
21	210586	09-009617-44	OIL SEAL	1
22	204093	09-009055-61	LEVER	1
23	5284	09-009067-39	SCREW	1
24	204293	09-009602-07	SPRING WASHER	1
25	XXXXXX		LOOPER	1
26	1189	09-009054-63	SCREW	1
27	204172	09-009064-31	WASHER	1
28	2922	09-009065-38	SCREW	1

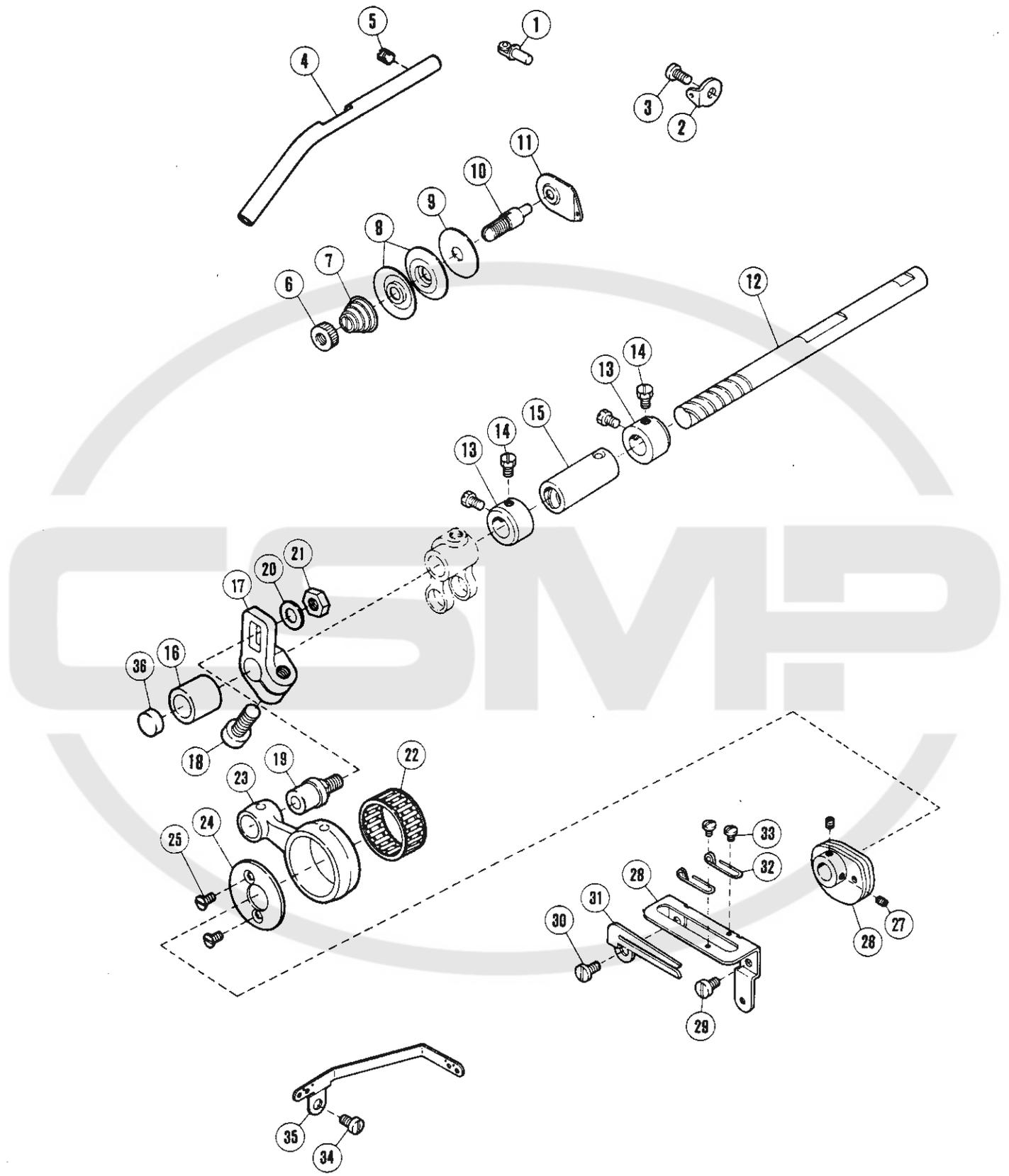

CHAINSTITCH LOOPER DRIVE MECHANISM (2)

REF. NO.	PART NO.	PFAFF-NO.	NAME	QT.
1	201048A	09-009049-29	THREAD EYELET	1
2	167079	09-009605-22	THREAD EYELET	1
3	5091	09-009067-20	SCREW	1
4	204099	09-009606-31	PIPE	1
5	1457	09-009048-64	SCREW	1
6	3056	09-009606-29	NUT	1
7	167077	09-009054-83	SPRING	1
8	210319	09-009615-68	TENSION DISC	2
9	208449	09-009607-60	FELT	1
10	167072	09-009054-81	TENSION POST	1
11	202849	09-009055-24	TENSION GUIDE	1
12	204874	09-009606-25	SHAFT/LOOPER AVOIDING	1
13	201056	09-009049-35	COLLAR	2
14	5084	09-009053-76	SCREW	4
15	204089	09-009055-57	BUSHING	1
16	210292	09-009615-45	BUSHING	1
17	210287	09-009615-40	CRANK/LOOPER AVOIDING	1
18	5457	09-009612-42	SCREW	1
19	210285	09-009615-39	PIN	1
20	208286	09-009607-02	WASHER	1
21	5455	09-009612-41	NUT	1
22	205015-2	09-009612-74	NEEDLE BEARING	1
23	210284	09-009615-38	CONNECTION/LOOPER AVOIDING	1
24	210283	09-009615-37	COLLAR	1
25	5259	09-009054-13	SCREW	2
26	204095A	09-009055-62	THREAD TAKEUP	1
27	5292	09-009064-89	SCREW	2
28	204097A	09-009055-63	BRACKET	1
29	5113	09-009054-70	SCREW	1
30	4009-1	09-009053-53	SCREW	1
31	204096	09-009054-30	THREAD TAKEUP	1
32	204324	09-009065-93	THREAD EYELET	2
33	5077	09-009054-69	SCREW	2
34	5113	09-009054-70	SCREW	1
35	208362	09-009606-30	THREAD GUIDE	1
36	205088	09-009604-86	PLUG	1

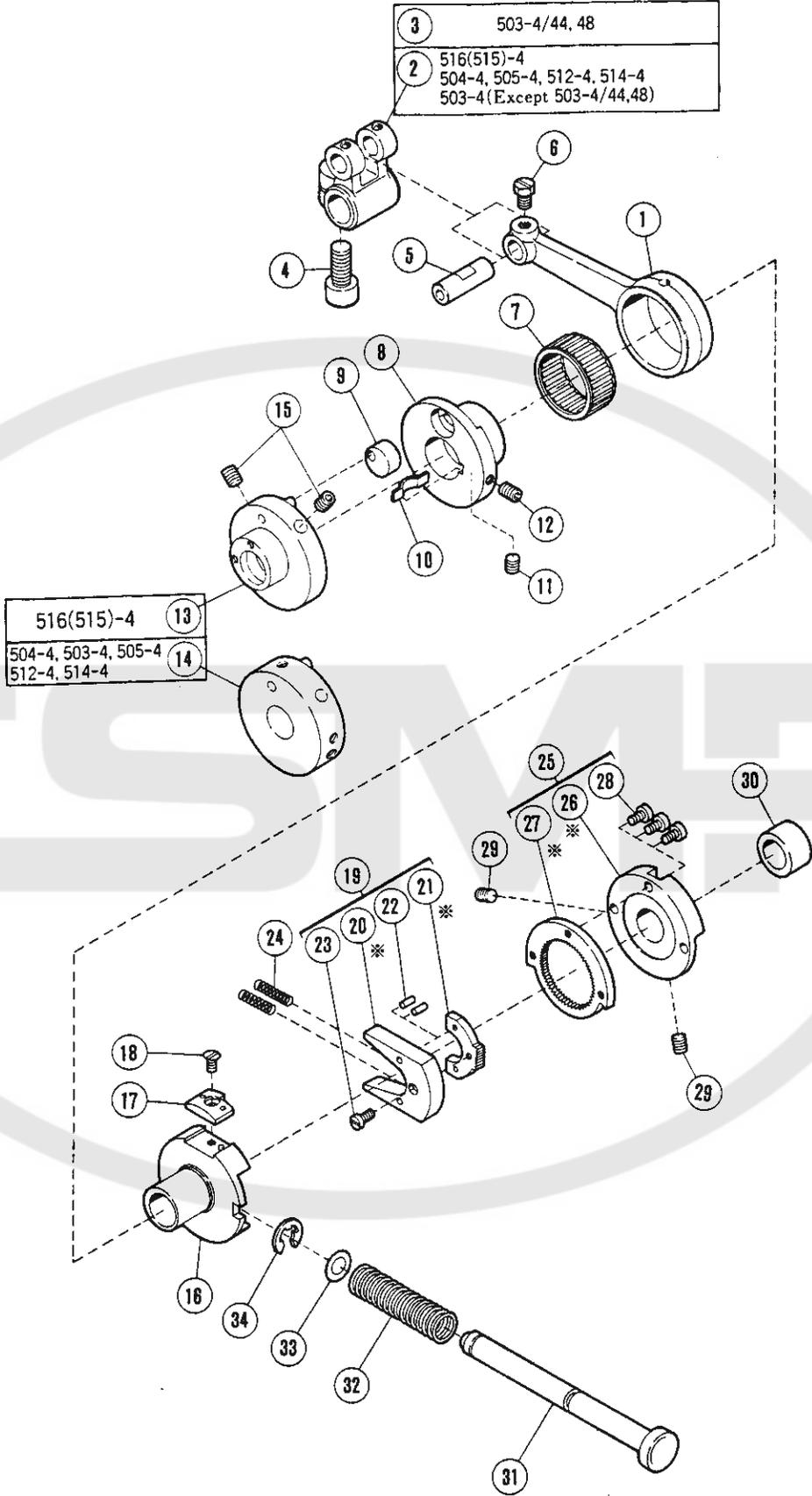

FEED MECHANISM (1)

REF. NO.	PART NO.	PFAFF-NO.	NAME	QT.
1	204100	09-009067-53	CONNECTION	1
2	204085	09-009055-53	CRANK/FEED DRIVE	1
3	208333	09-009601-38	CRANK/FEED DRIVE	1
4	5381	09-009069-26	SCREW	1
5	205495-2	09-009603-81	PIN	1
6	5084	09-009053-76	SCREW	1
7	204084-2	09-009055-52	NEEDLE BEARING	1
8	210127	09-009614-04	ECCENTRIC/FEED DRIVE	1
9	210129	09-009614-06	GUIDE/FEED ECCENTRIC	1
10	210130	09-009614-07	FLAT SPRING	1
11	5292	09-009064-89	SCREW	1
12	5427	09-009611-79	SCREW	1
13	210282A	09-009823-93	ECCENTRIC/LOOPER AVOIDING	1
14	210128A	09-009815-66	FEED ECCENTRIC RETAINER	1
15	5461	09-009612-44	SCREW	2
16	211802A	09-009823-89	ECCENTRIC/FEED REGULATING	1
17	211804	09-009733-33	STOPPER	1
18	5437	09-009606-28	SCREW	1
19	208411	09-009607-41	FEED REGULATING RATCHET	1
*20	208413	09-009607-41	BRACKET	1
*21	208412	09-009607-42	RATCHET	1
22	206781	09-009820-18	PIN	2
23	5336	09-009601-19	SCREW	1
24	208415	09-009607-44	SPRING	2
25	210136	09-009614-11	RATCHET WHEEL COMPLETE	1
*26	211807	09-009840-11	BRACKET	1
*27	211806	09-009840-10	WHEEL	1
28	5157	09-009804-01	SCREW	3
29	5461	09-009612-44	SCREW	2
30	208944	09-009833-75	SPACER	1
31	209304	09-009833-86	PUSH BUTTON	1
32	208421	09-009607-49	SPRING	1
33	208949	15-120911-05	O RING	1
34	202522	09-009052-03	RING	1

Notice) Parts with mark * are not for sale.

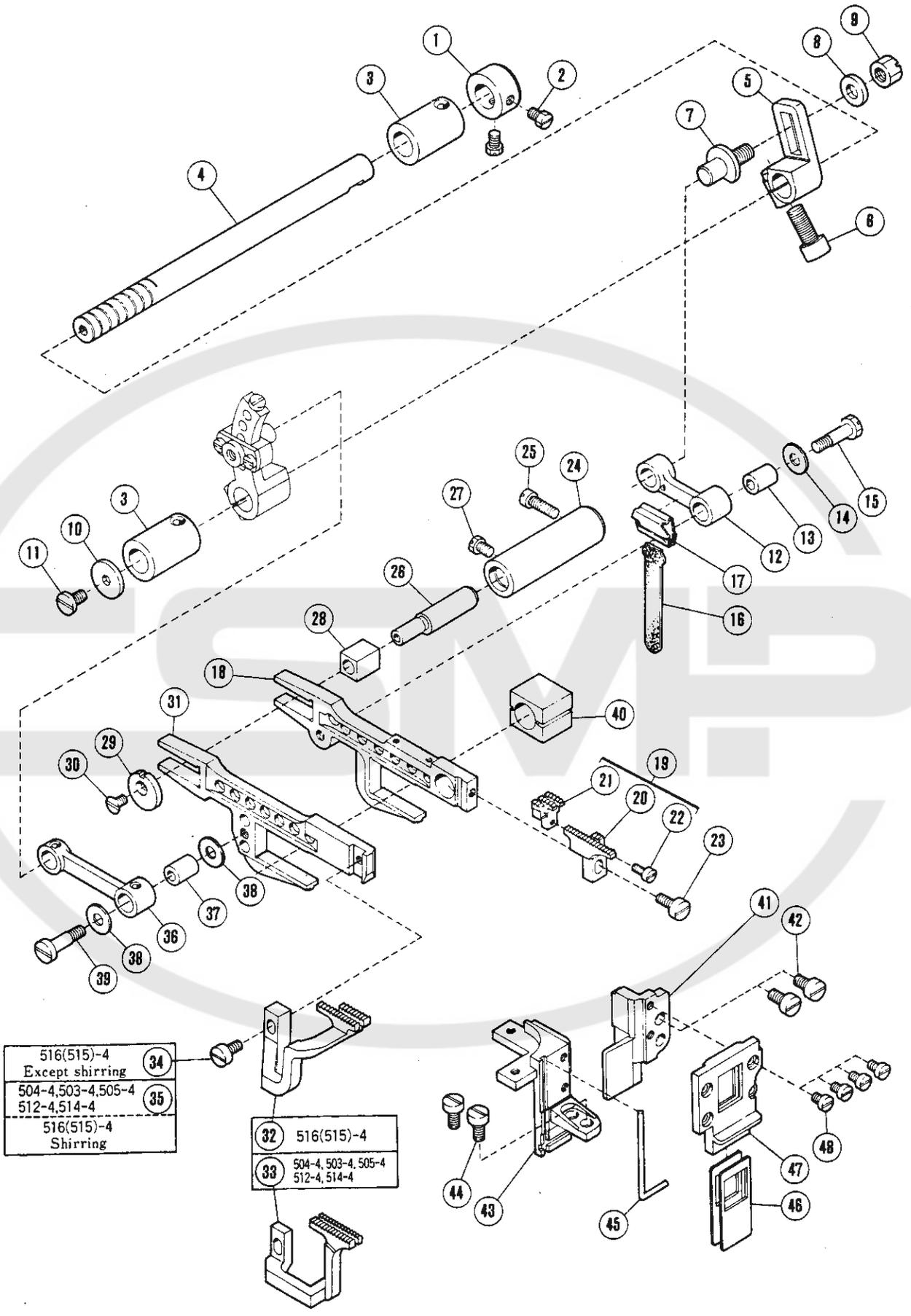

FEED MECHANISM (2)

PLEASE NOTE :「XXXXXX」 is one of the gauge parts.
So please refer to pages 74~132 and
confirm the correct parts.

REF. NO.	PART NO.	PFAFF-NO.	NAME	QT.
1	201056	09-009049-35	COLLAR	1
2	5084	09-009053-76	SCREW	2
3	209169	09-009800-48	BUSHING	2
4	204751	09-009068-20	SHAFT	1
5	208284	09-009605-56	CRANK/MAIN FEED	1
6	5381	09-009069-26	SCREW	1
7	208285	09-009607-01	SCREW	1
8	208286	09-009607-02	WASHER	1
9	5455	09-009612-41	NUT	1
10	204107	09-009067-58	WASHER	1
11	4009-1	09-009053-53	SCREW	1
12	204111A	09-009067-57	LINK/MAIN FEED	1
13	204114	09-009064-01	BUSHING	1
14	204115	09-009064-02	WASHER	1
15	5231	09-009054-77	SCREW	1
16	204618	09-009602-18	OIL WICK	1
17	204588	09-009602-16	RETAINER	1
18	204123A	09-009067-27	MAIN FEED BAR	1
19	XXXXXX		MAIN FEED DOG COMPLETE	1
20	XXXXXX		MAIN FEED DOG	1
21	XXXXXX		AUXILIARY FEED DOG	1
22	2922	09-009065-38	SCREW	1
23	1175-2	09-009048-13	SCREW	1
24	204129A	09-009601-84	BUSHING	1
25	2133-1	09-009053-36	SCREW	1
26	204128A	09-009601-83	PIN	1
27	5084	09-009053-76	SCREW	1
28	205857	09-400106-00	BLOCK/FEED BAR GUIDE	1
29	204439A	09-009602-09	WASHER	1
30	5317	09-009601-17	SCREW	1
31	204124	09-009067-28	DIFFERENTIAL FEED BAR	1
32	XXXXXX		DIFFERENTIAL FEED DOG	1
33	XXXXXX		DIFFERENTIAL FEED DOG	1
34	1175-3	09-009048-14	SCREW	1
35	1189	09-009054-63	SCREW	1
36	204122	09-009064-08	LINK/DIFFERENTIAL FEED	1
37	204114	09-009064-01	BUSHING	1
38	204115	09-009064-02	WASHER	2
39	5231	09-009054-77	SCREW	1
40	204810	09-009067-63	BLOCK/FEED BAR LIFT	1
41	208108	09-009604-68	GUIDE (RIGHT)/FEED BAR	1
42	5205	09-009069-93	SCREW	2
43	208952	09-009800-37	GUIDE (LEFT)/FEED BAR	1
44	5205	09-009069-93	SCREW	2
45	208168	09-009604-71	GASKET	1
46	208109	09-009604-69	OIL SHIELD/FEED BAR GUIDE	2
47	208625	09-009800-16	INSERT PLATE	1
48	5346	09-009068-79	SCREW	4

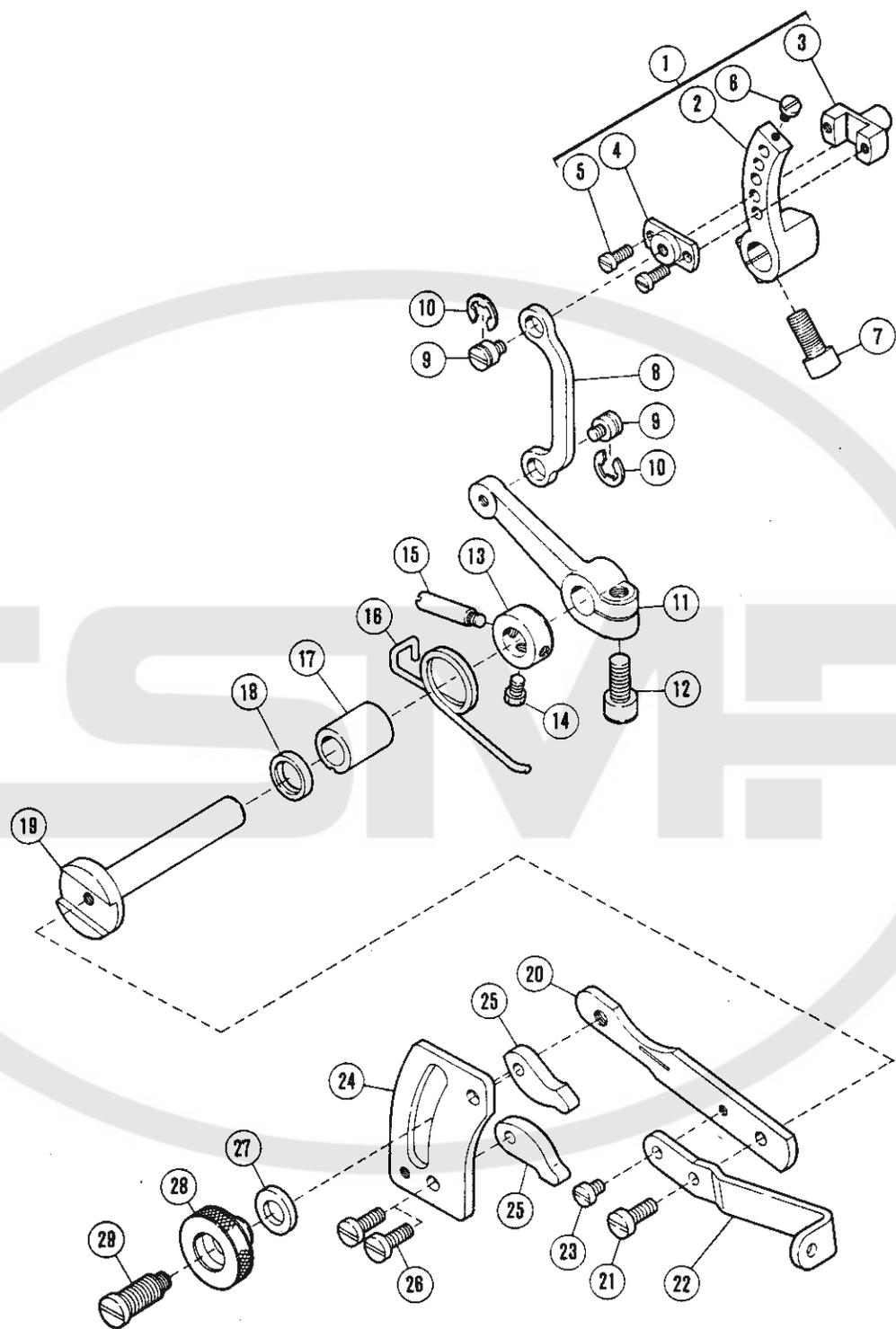

FEED MECHANISM (3)

REF. NO.	PART NO.	PFAFF-NO.	NAME	QT.
1	208273	09-009605-51	REGULATOR COMPLETE/DIFF. FEED	1
2	208274	09-009605-52	CRANK	1
3	208275	09-009605-53	BLOCK	1
4	208276	09-009605-54	COVER	1
5	5029	09-009053-59	SCREW	2
6	5141	09-009600-24	SCREW	1
7	5381	09-009069-26	SCREW	1
8	204140A	09-009064-18	LINK/DIFF. FEED REGULATING	1
9	5316	09-009601-16	SCREW	2
10	202522	09-009052-03	RING	2
11	204139A	09-009064-17	LEVER/DIFF. FEED REGULATING	1
12	5381	09-009069-26	SCREW	1
13	204754A	09-009814-34	COLLAR	1
14	5084	09-009053-76	SCREW	1
15	204757	09-009068-27	PIN	1
16	204756	09-009068-26	SPRING	1
17	210164	09-009614-36	BUSHING	1
18	204052A	09-009064-62	OIL SEAL	1
19	204752	09-009068-21	SHAFT	1
20	204755	09-009068-24	LEVER/DIFF. FEED REGULATING	1
21	5118	09-009053-89	SCREW	1
22	204883	09-009602-46	LEVER	1
23	1216	09-009048-20	SCREW	1
24	204142B	09-009601-85	REGULATING PLATE	1
25	204143A	09-009601-86	STOPPER	2
26	5118	09-009053-89	SCREW	2
27	202868	09-009069-58	WASHER	1
28	204870	09-009602-44	THUMB NUT	1
29	5321A	09-009069-59	SCREW	1

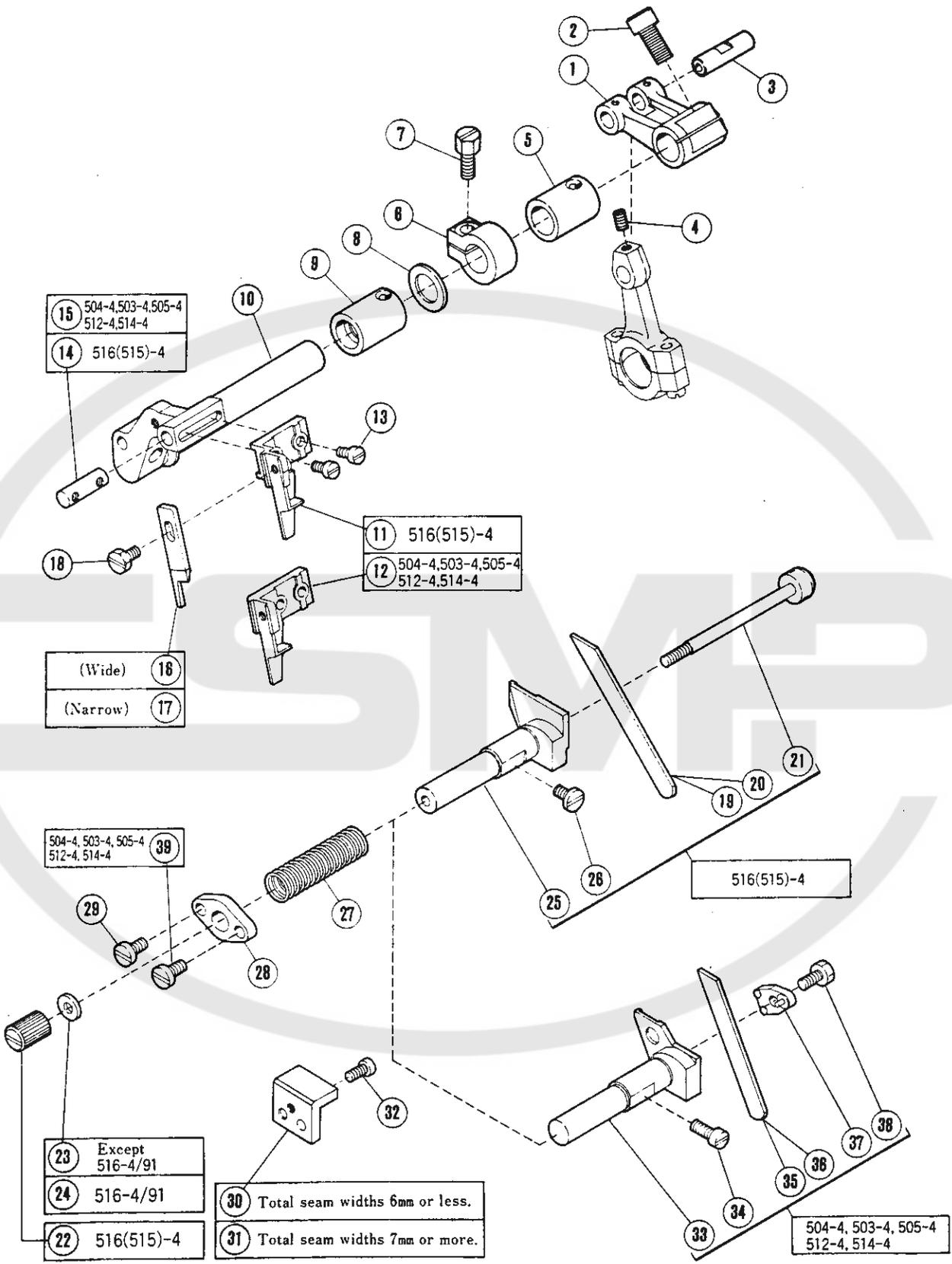

KNIFE DRIVE MECHANISM

REF. NO.	PART NO.	PFAFF-NO.	NAME	QT.
1	204147	09-009064-19	CRANK/UPPER KNIFE	1
2	5381	09-009069-26	SCREW	1
3	204146	09-009065-81	PIN	1
4	1458	09-009048-66	SCREW	1
5	210067	09-009613-54	BUSHING	1
6	206181B	09-009833-48	COLLAR	1
7	5001	09-009814-58	SCREW	1
8	208235	09-009606-51	WASHER	1
9	204149	09-009601-87	BUSHING	1
10	208693	09-009800-19	UPPER KNIFE LEVER	1
11	208402	09-009606-87	UPPER KNIFE CLAMP	1
12	204638	09-009068-15	UPPER KNIFE CLAMP	1
13	1175-2	09-009048-13	SCREW	2
14	204154	09-009066-28	PIN	1
15	204796	09-009601-92	PIN	1
16	201121A	09-009050-06	UPPER KNIFE	1
17	202527A	09-009070-82	UPPER KNIFE (NARROW)	1
18	5088	09-009053-80	SCREW	1
19	204161	09-009053-33	LOWER KNIFE	1
20	204351	09-009606-90	LOWER KNIFE	1
21	204162	09-009064-26	CLAMP STUD/LOWER KNIFE	1
22	5260	09-009054-14	NUT	1
23	200098	09-009048-70	WASHER	1
24	209173	09-009800-49	WASHER	1
25	208404	09-009606-88	LOWER KNIFE HOLDER	1
26	4009-1	09-009053-53	SCREW	1
27	204158	09-009064-24	SPRING	1
28	204159	09-009064-25	STOPPER	1
29	5117	09-009053-88	SCREW	1
30	204160A	09-009601-89	GUIDE/LOWER BAR	1
31	208096	09-009601-95	GUIDE/LOWER KNIFE HOLDER	1
32	1175-2	09-009048-13	SCREW	1
33	208851	09-009601-93	LOWER KNIFE HOLDER	1
34	5002	09-009053-54	SCREW	1
35	202295	09-009066-42	LOWER KNIFE/THICK	1
36	201127	09-009054-43	LOWER KNIFE/THIN	1
37	210184	09-009614-52	CLAMP/LOWER KNIFE	1
38	2193	09-009053-37	SCREW	1
39	5117	09-009053-88	SCREW	1

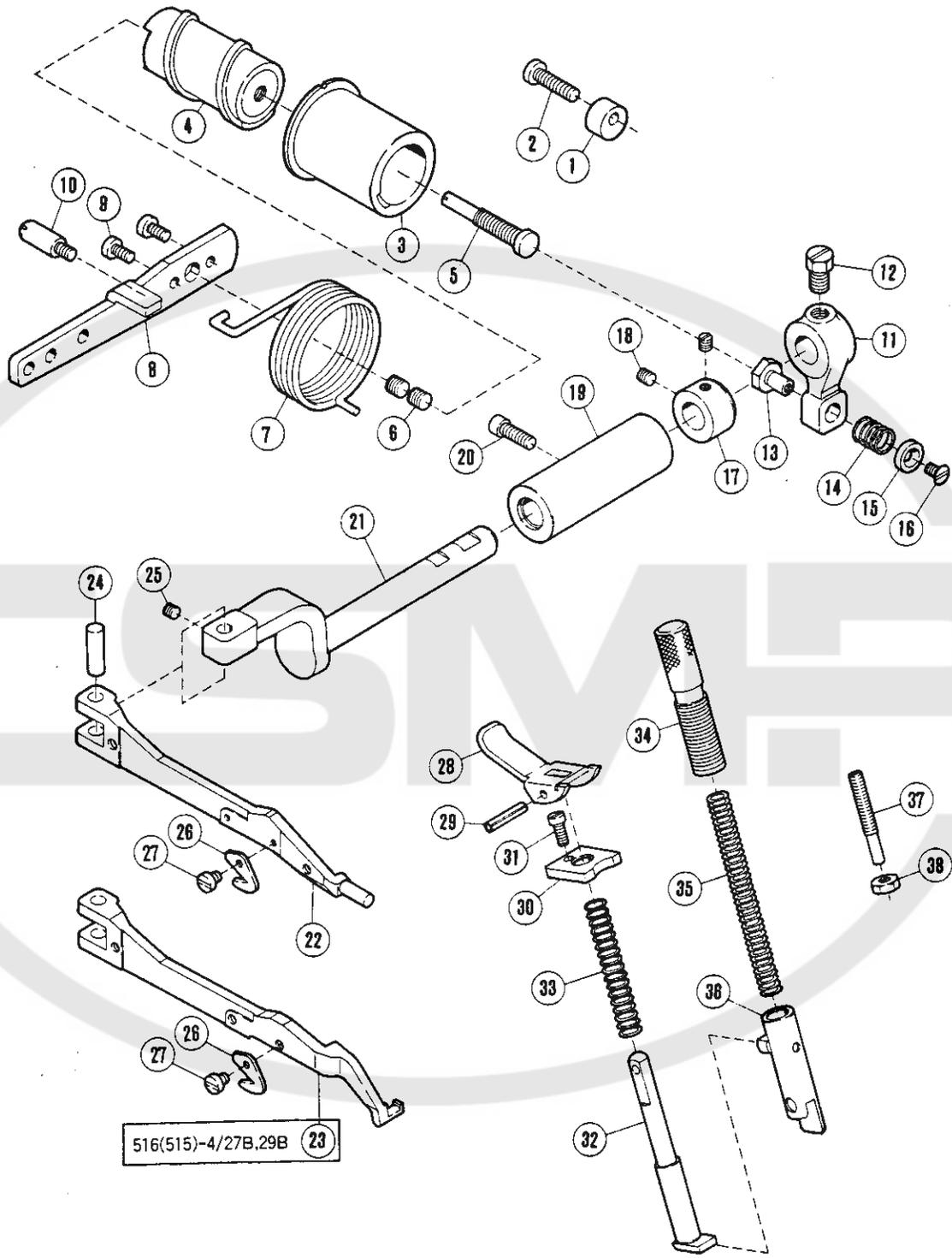

516(515)-4/27B.29B 23

PRESSER FOOT MECHANISM (1)

REF. NO.	PART NO.	PFAFF-NO.	NAME	QT.
1	202683	09-009065-85	STOPPER	1
2	5118	09-009053-89	SCREW	1
3	204930	09-009603-23	BUSHING	1
4	204929	09-009603-22	FOOT LIFT CAM	1
5	208316	09-009607-14	SCREW	1
6	2913-2	09-009600-20	SCREW	2
7	204178	09-009064-36	SPRING	1
8	204177B	09-009067-41	LEVER/FOOT LIFT	1
9	1202	09-009048-17	SCREW	2
10	5232	09-009064-50	SCREW	1
11	208313	09-009607-11	LEVER/INTERMEDIATE	1
12	2022-4	09-009051-78	SCREW	1
13	208314	09-009607-12	PIN	1
14	208315	09-009607-13	SPRING	1
15	202757A	09-009053-13	WASHER	1
16	5317	09-009601-17	SCREW	1
17	201056	09-009049-35	COLLAR	1
18	1457	09-009048-64	SCREW	2
19	208535	09-009607-72	BUSHING	1
20	2133-1	09-009053-36	SCREW	1
21	208534	09-009607-71	SHAFT/FOOT LIFT	1
22	208526	09-009607-70	PRESSER ARM	1
23	209337	09-009839-90	PRESSER ARM	1
24	208549	09-009607-75	PIN	1
25	1457-1	09-009048-65	SCREW	1
26	202451	09-009051-81	CHAIN CUTTER	1
27	2921	09-009053-46	SCREW	1
28	208598	09-009607-94	LEVER/HAND LIFT	1
29	202647A	09-009065-79	PIN	1
30	208599	09-009607-95	BUSHING	1
31	5029	09-009053-59	SCREW	1
32	202645	09-009054-98	PLUNGER	1
33	201395	09-009601-61	SPRING	1
34	208774	09-009612-99	THUMB SCREW	1
35	208773	09-009800-24	SPRING	1
36	208537	09-009607-73	PRESSER BAR COMPLETE	1
37	5271	09-009601-08	SCREW	1
38	3044	09-009053-49	NUT	1

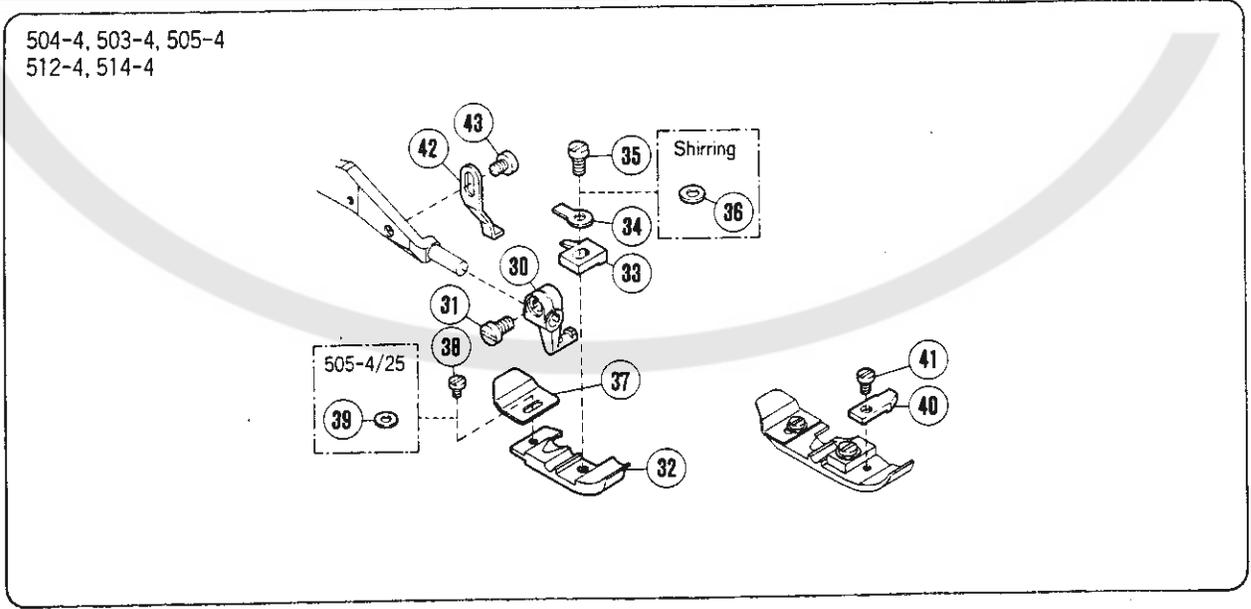
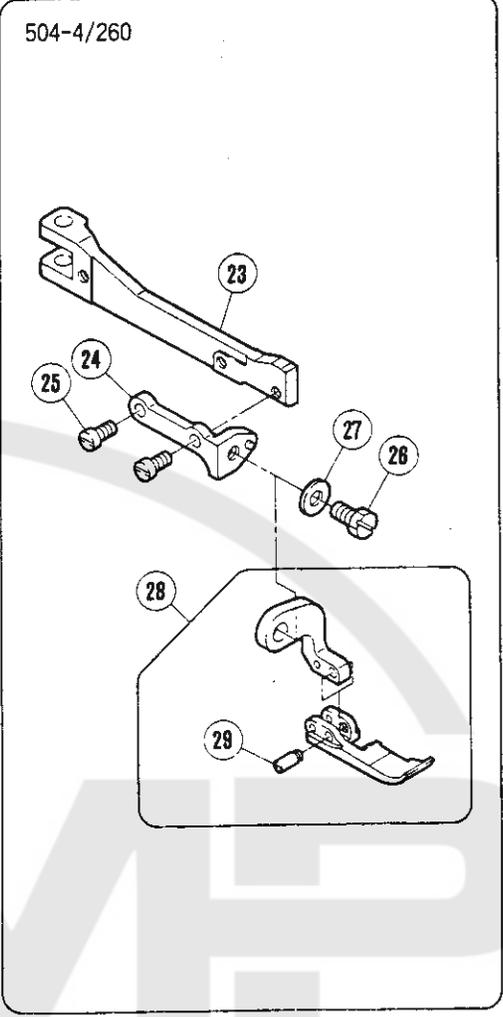
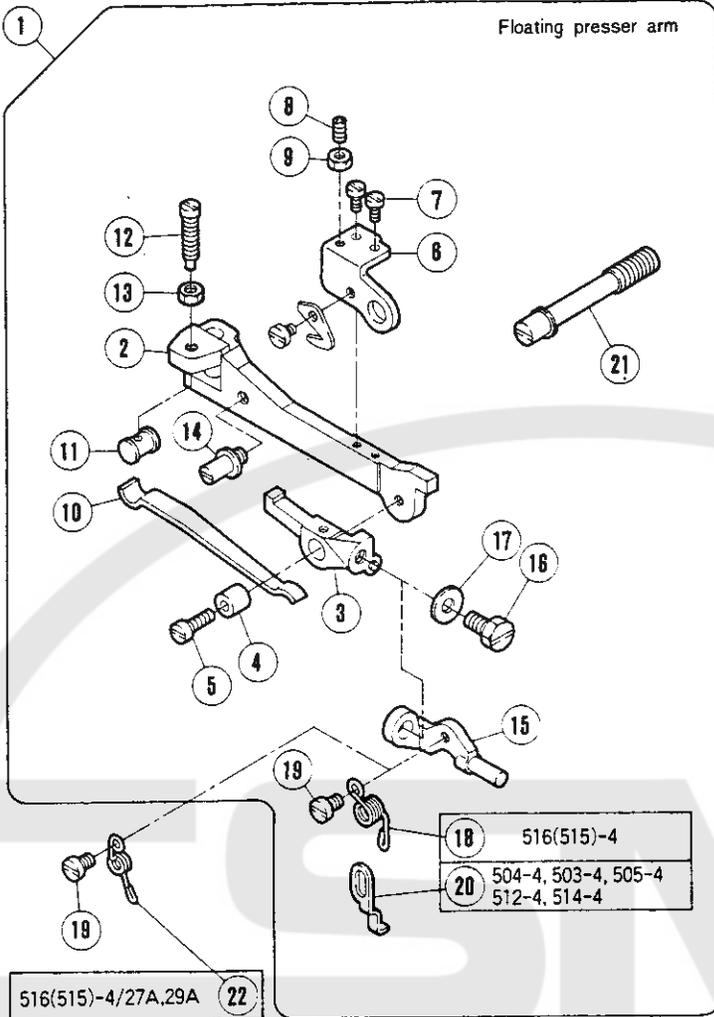

PRESSER FOOT MECHANISM (2)

PLEASE NOTE :「XXXXXX」 is one of the gauge parts.
So please refer to pages 74~132 and
confirm the correct parts.

REF. NO.	PART NO.	PFAFF-NO.	NAME	QT.
1	209307	09-009833-87	PRESSER ARM COMPLETE	1
2	209308	09-009833-88	PRESSER ARM	1
3	209309	09-009833-89	LEVER	1
4	211511	09-009735-01	BUSHING	1
5	5003	09-009600-21	SCREW	1
6	209311	09-009833-90	LEVER HOLDER	1
7	2922	09-009065-38	SCREW	2
8	5427	09-009611-79	SCREW	1
9	5409	09-009070-04	NUT	1
10	211514	09-009735-04	FLAT SPRING	1
11	209312	09-009833-91	SPRING GUIDE	1
12	5538	09-009734-80	SCREW	1
13	3091	09-009053-50	NUT	1
14	209313	09-009833-92	SCREW	1
15	211516	09-009735-06	BRACKET	1
16	2193	09-009053-37	SCREW	1
17	201185	09-009050-38	WASHER	1
18	211517	09-009735-07	SPRING	1
19	2921	09-009053-46	SCREW	1
20	209314	09-009734-89	STOPPER/PRESSER FOOT	1
21	5552	09-009833-39	SCREW	1
22	211944	09-009810-27	SPRING	1
23	209232	09-009806-87	PRESSER ARM	1
24	209230	09-009806-99	BRACKET	1
25	1196	09-009048-16	SCREW	2
26	2193	09-009053-37	SCREW	1
27	201185	09-009050-38	WASHER	1
28	209226	09-009621-97	PRESSER FOOT COMPLETE	1
29	209229-B	09-009833-83	SCREW	1
30	208525-B	09-009807-37	BRACKET/PRESSER FOOT	1
31	5328	09-009071-11	SCREW	1
32	XXXXXX		PRESSER FOOT	1
33	XXXXXX		PRESSER FOOT FINGER	1
34	201156	09-009050-20	SET PLATE/PRESSER FOOT	1
35	5089	09-009053-81	SCREW	1
36	202588	09-009052-70	WASHER	1
37	XXXXXX		PRESSER FOOT UNCURLER	1
38	5030	09-009053-60	SCREW	1
39	210585	09-009617-43	WASHER	1
40	XXXXXX		FABRIC GUARD	1
41	1231	09-009048-09	SCREW	1
42	208547	09-009602-03	REGULATOR	1
43	2921	09-009053-46	SCREW	1

516(515)-4

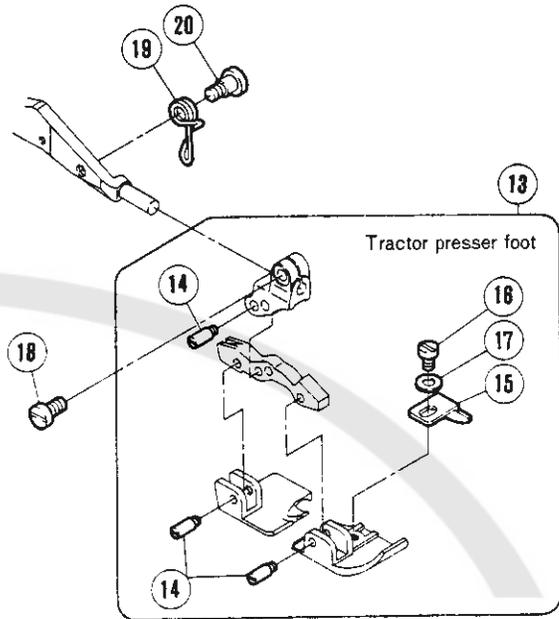
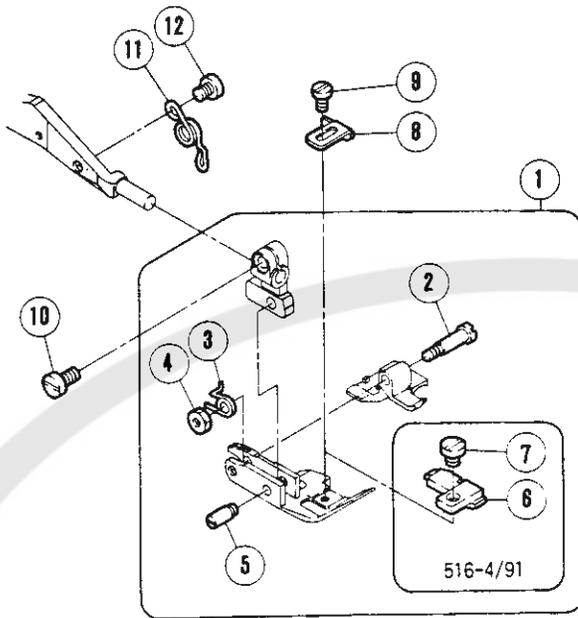

516(515)-4/27A,29A

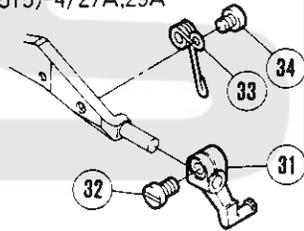

516(515)-4/27B,29B

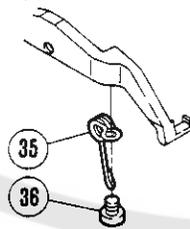

21

Small foot
(Good for cornering)

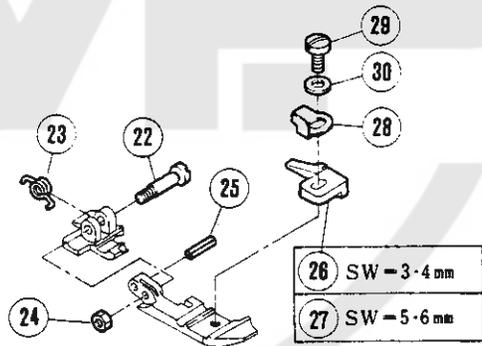

PRESSER FOOT MECHANISM (3)

PLEASE NOTE :「XXXXXX」 is one of the gauge parts.
So please refer to pages 74~132 and
confirm the correct parts.

REF. NO.	PART NO.	PFAFF-NO.	NAME	QT.
1	XXXXXX		PRESSER FOOT COMPLETE	1
2	208528-B	09-009612-97	SCREW	1
3	208913	09-009613-00	SPRING	1
4	5409	09-009070-04	NUT	1
5	208958-B	09-009734-88	SCREW	1
6	208891	09-009833-71	PRESSER FOOT FINGER	1
7	2921	09-009053-46	SCREW	1
8	XXXXXX		FABRIC GUARD	1
9	5030	09-009053-60	SCREW	1
10	5328	09-009071-11	SCREW	1
11	208529	09-009606-96	SPRING	1
12	2921	09-009053-46	SCREW	1
13	XXXXXX		PRESSER FOOT COMPLETE	1
14	208958-B	09-009734-88	SCREW	3
15	204683	09-009609-34	FABRIC GUARD	1
16	5157	09-009804-01	SCREW	1
17	202875	09-009601-76	WASHER	1
18	5328	09-009071-11	SCREW	1
19	208978	09-009800-40	SPRING	1
20	5291	09-009065-72	SCREW	1
21	XXXXXX		PRESSER FOOT COMPLETE	1
22	211919	09-009819-15	PIN	1
23	211918	09-009806-68	SPRING	1
24	3150	09-009833-36	NUT	1
25	211920	09-009840-15	PIN	1
26	211915	09-009830-74	PRESSER FOOT FINGER	1
27	211916	09-009830-27	PRESSER FOOT FINGER	1
28	211917	09-009733-45	BRACKET	1
29	5089	09-009053-81	SCREW	1
30	300248	09-009070-98	WASHER	1
31	211905	09-009803-53	BRACKET/PRESSER FOOT	1
32	5328	09-009071-11	SCREW	1
33	209338	09-009839-91	SPRING	1
34	2921	09-009053-46	SCREW	1
35	211904	09-009803-56	SPRING	1
36	2921	09-009053-46	SCREW	1

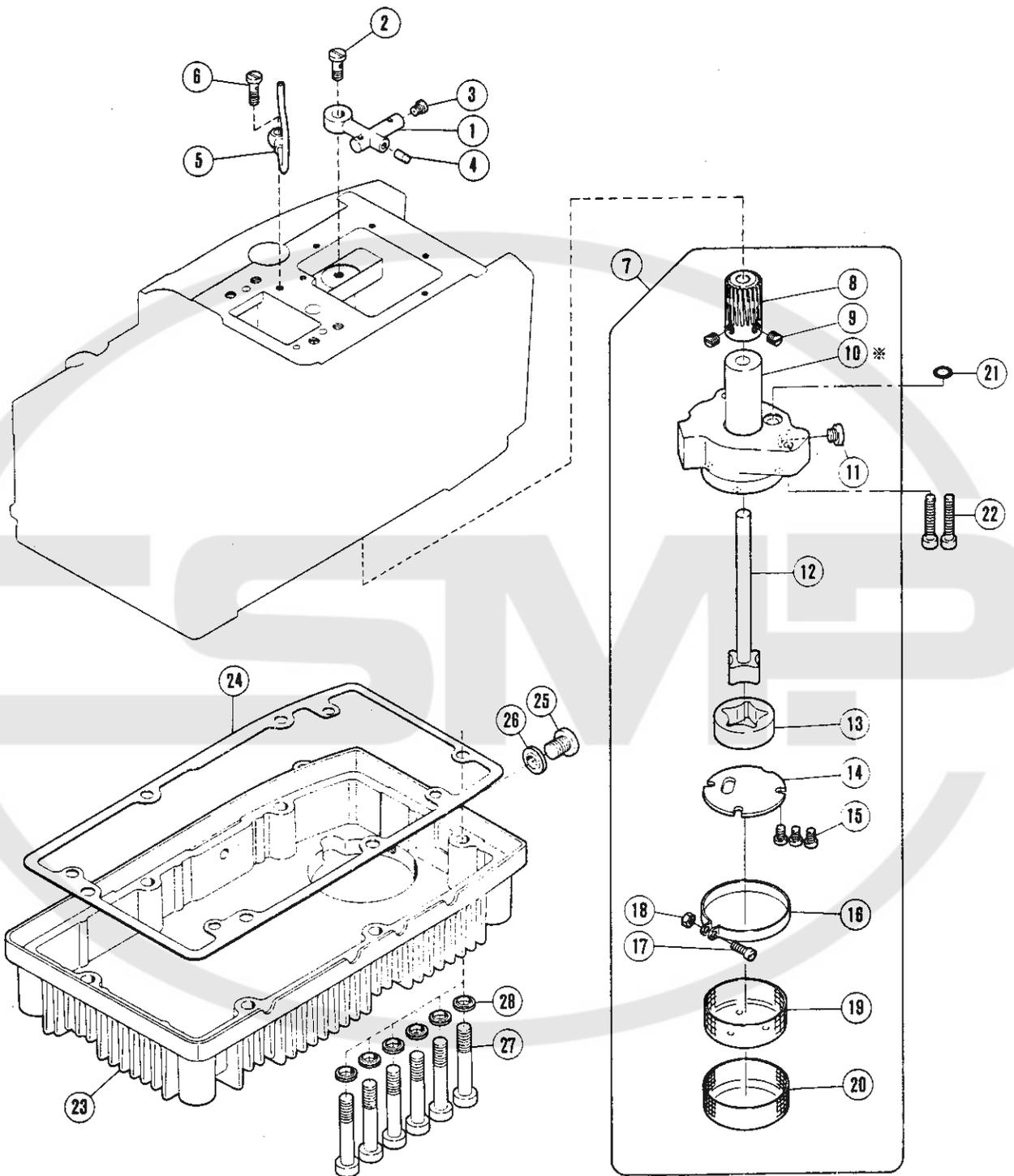

LUBRICATION MECHANISM

REF. NO.	PART NO.	PFAFF-NO.	NAME	QT.
1	204193	09-009069-36	OIL DISTRIBUTOR	1
2	200152	09-009069-37	JOINT SCREW	1
3	201323	09-009051-22	SCREW	1
4	202903	09-009065-53	PLUG	1
5	204194	09-009064-40	PIPE COMPLETE	1
6	201758	09-009051-57	JOINT SCREW	1
7	204593	09-009602-17	TROCHOID PUMP ASSEMBLY	1
8	204187	09-009064-38	WORM WHEEL	1
9	5060	09-009053-64	SCREW	2
*10	209407	09-009840-02	TROCHOID PUMP	1
11	5145	09-009600-26	SCREW	1
12	212978-91	09-009820-04	ROTOR (INSIDE) SHAFT	1
13	212981	09-009820-07	ROTOR (OUTSIDE)	1
14	212982A	09-009840-16	PLATE	1
15	5328	09-009071-11	SCREW	3
16	209410	09-009840-05	CLAMP	1
17	1170-1	09-009048-12	SCREW	1
18	3091	09-009053-50	NUT	1
19	209408	09-009840-03	FILTER (INSIDE)	1
20	209409	09-009840-04	FILTER (OUTSIDE)	1
21	204185	09-009067-40	O RING	1
22	5094	09-009053-82	SCREW	2
23	208260	09-009605-50	OIL RESERVOIR	1
24	208318	09-009607-16	GASKET	1
25	5138B	09-009067-17	SCREW	1
26	202287A	09-009051-76	WASHER	1
27	5150B	09-009053-98	BOLT	6
28	204806	09-009602-24	WASHER	6

Notice) Parts with mark ※ are not for sale.

OPTION

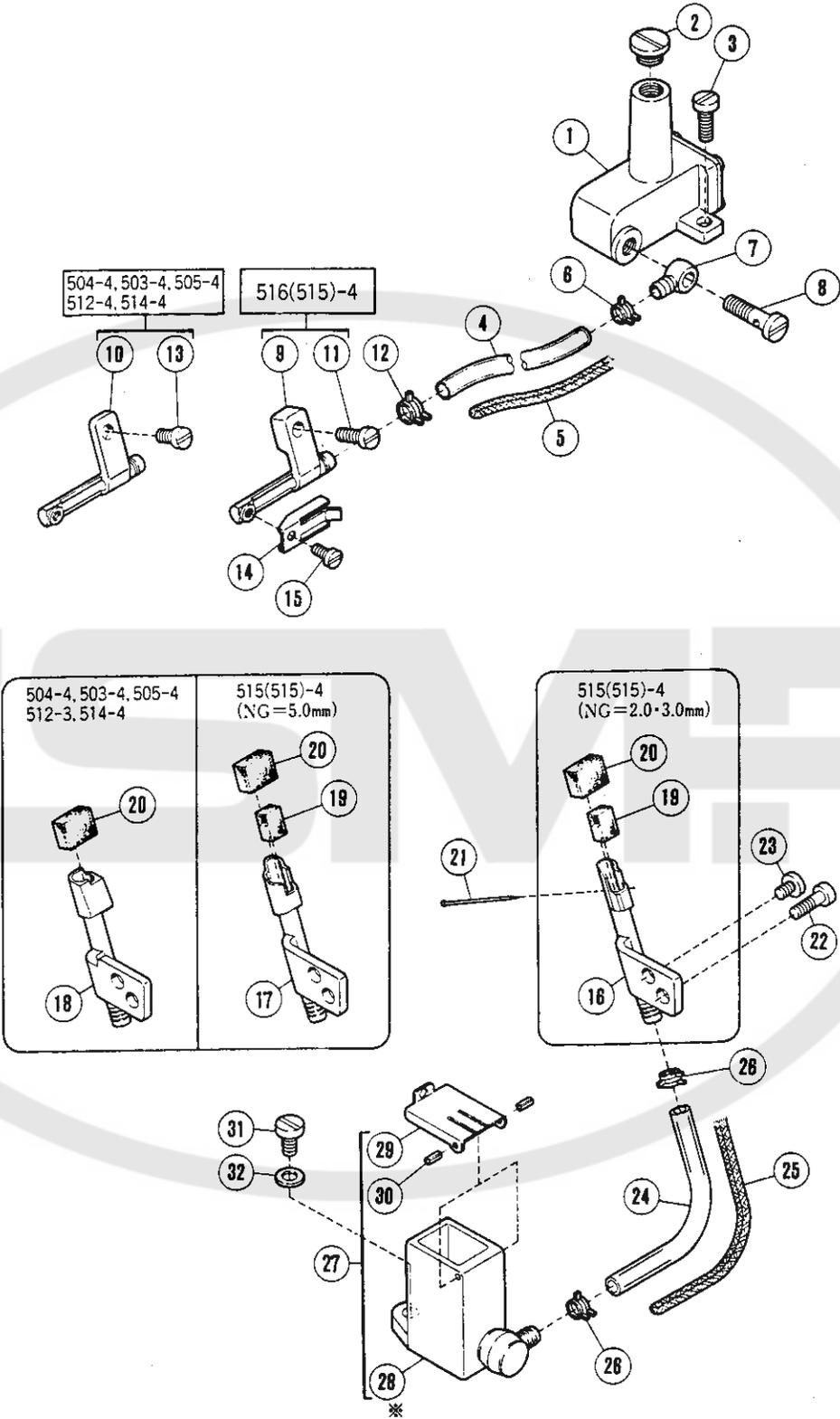

H.R. DEVICE (OPTION)

REF. NO.	PART NO.	PFAFF-NO.	NAME	QT.
1	208308	09-009607-10	SILICONE OIL RESERVOIR (UPPER)	1
2	5242	09-009601-06	SCREW	1
3	5118	09-009053-89	SCREW	1
4	204921	09-009603-18	TUBE	1
5	202176	26-536302-09	OIL WICK	1
6	200155	09-009065-56	TUBE CLAMP	1
7	200136	09-009054-86	JOINT	1
8	200152	09-009069-37	JOINT SCREW	1
9	208486	09-009607-27	THREAD LUBRICATOR	1
10	208446	09-009602-33	THREAD LUBRICATOR	1
11	5345	09-009070-23	SCREW	1
12	202199	09-009829-30	CLAMP	1
13	4009-1	09-009053-53	SCREW	1
14	208487	09-009607-65	PLATE	1
15	5012	09-009065-32	SCREW	1
16	204259	09-009068-76	TUBE	1
17	204435	09-009607-34	TUBE	1
18	204651	09-009602-41	TUBE	1
19	240178	09-009823-80	OIL FELT	1
20	204466	09-009607-37	OIL WICK	1
21	210766	09-009618-38	PIN	1
22	5010	09-009053-55	SCREW	1
23	1206	09-009048-19	SCREW	1
24	204921	09-009603-18	TUBE	1
25	202176	26-536302-09	OIL WICK	1
26	200155	09-009065-56	TUBE CLAMP	2
27	209411-91	09-009840-06	SILICONE OIL RESERVOIR (LOWER)	1
*28	209412-91	09-009840-07	SILICONE OIL RESERVOIR (LOWER)	1
29	204862	09-009602-30	CAP COVER	1
30	206781	09-009820-18	PIN	2
31	5345	09-009070-23	SCREW	1
32	201185	09-009050-38	WASHER	1

Notice) Parts with mark * are not for sale.

504-4/21P1, P2
 514-4/62P1, P2
 516-4/38P1, P2

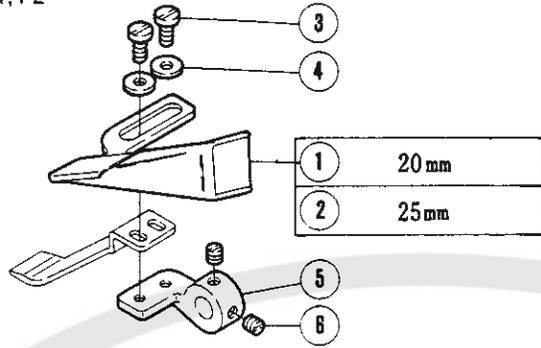

504-4/21P2
 514-4/62P2
 516-4/38P2



- ① • 504-4/21P2, 514-4/62P2
 • 516-4/38P2 (Option)
- ② • 516-4/38P2
 • 504-4/21P2, 514-4/62P2 (Option)

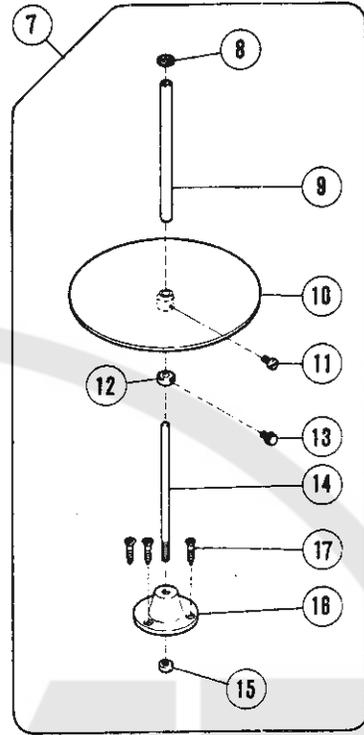

504-4/21P1, 504-4/21P2
 514-4/62P1, 514-4/62P2

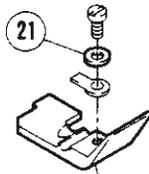

①⑧ CD=2.0mm
 ②⑩ CD=3.0mm

CD=Cord Diameter

516(515)-4/38P1, 516(515)-4/38P2

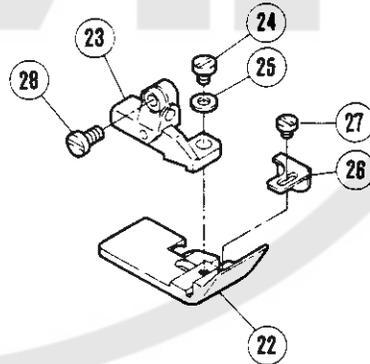

ATTACHMENT FOR PIPING (1)

REF. NO.	PART NO.	PFAFF-NO.	NAME	QT.
1	211885	09-009803-51	BINDER (20)	1
2	211886	09-009803-52	BINDER (25)	1
3	1202	09-009048-17	SCREW	2
4	167066	09-009601-53	WASHER	2
5	210962	09-009618-79	BRACKET/BINDER	1
6	5210	09-009618-57	SCREW	2
7	403	09-009732-44	TAPE DISC ASSEMBLY	1
8	406	09-009732-47	FELT	1
9	405	09-009732-46	FIXING ROD	1
10	404	09-009732-45	TAPE DISC	1
11	4012	09-009612-25	SCREW	1
12	407	09-009732-48	COLLAR	1
13	408	09-009732-49	ADJUSTING SCREW	1
14	409	09-009732-50	SHAFT	1
15	4818	09-009732-56	NUT	1
16	410-JA	09-009813-01	BRACKET	1
17	4908	09-009732-57	SCREW	3
18	413	09-009732-52	TAPE INSERTING TOOL	1
19	208782	09-009801-95	PIPING FOOT	1
20	208783	09-009833-70	PIPING FOOT	1
21	202588	09-009052-70	WASHER	1
22	204502A	09-009813-26	PIPING FOOT	1
23	208554	09-009606-77	BRACKET COMPLETE	1
24	2921	09-009053-46	SCREW	1
25	202875	09-009601-76	WASHER	1
26	204460	09-009071-51	FABRIC GUARD	1
27	5077	09-009054-69	SCREW	1
28	5328	09-009071-11	SCREW	1

514-4/64P1, 514-4/64P2
 504-4/47P1, 504-4/47P2

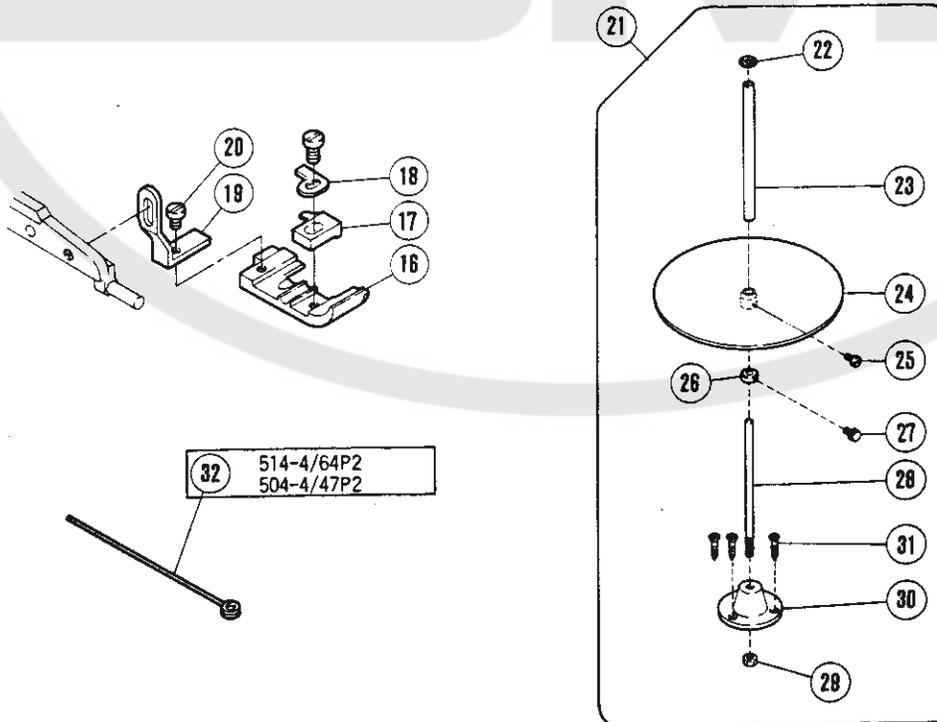
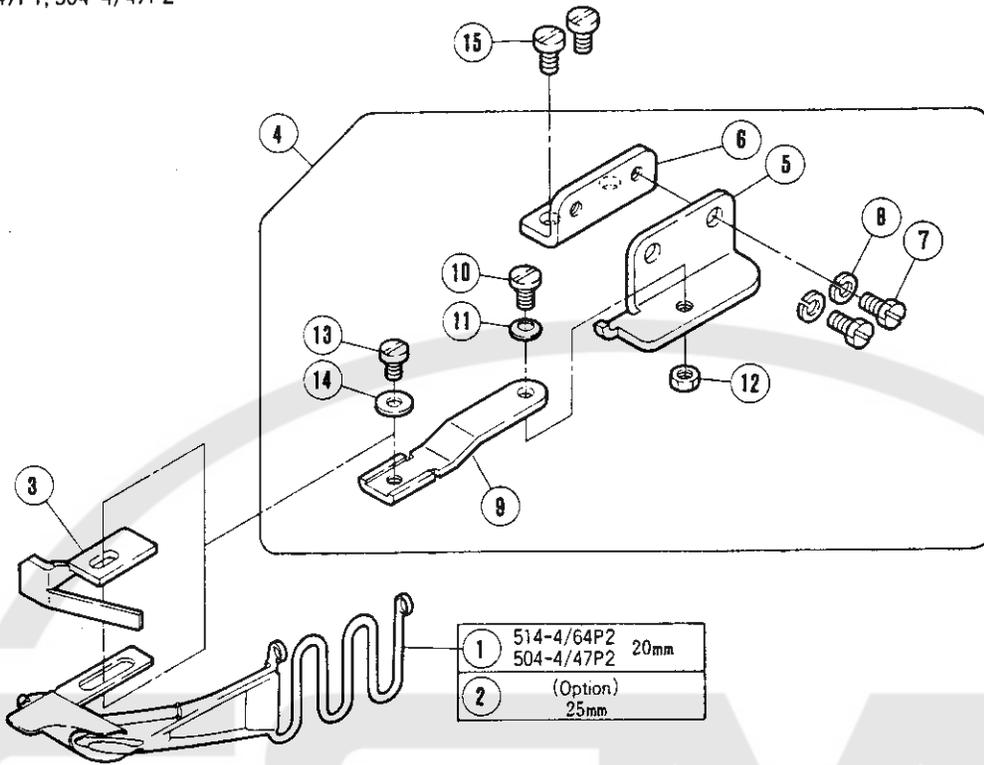

ATTACHMENT FOR PIPING (2)

PLEASE NOTE :「XXXXXX」 is one of the gauge parts.
So please refer to pages 74~132 and
confirm the correct parts.

REF. NO.	PART NO.	PFAFF-NO.	NAME	QT.
1	211880	09-009733-41	BINDER (20)	1
2	211946	09-009733-47	BINDER (25)	1
3	211879	09-009733-40	EDGE GUIDE	1
4	209335	09-009839-89	GUIDE SET	1
5	204452	09-009602-12	BRACKET/EDGE GUIDE	1
6	204451	09-009602-11	BRACKET	1
7	2193	09-009053-37	SCREW	2
8	202286	09-009051-75	SPRING WASHER	2
9	209324	09-009833-93	HINGE	1
10	5184	09-009054-02	SCREW	1
11	201191	09-009050-43	SPRING	1
12	3044	09-009053-49	NUT	1
13	1202	09-009048-17	SCREW	1
14	167066	09-009601-53	WASHER	1
15	5117	09-009053-88	SCREW	2
16	211873-TA	09-009801-78	PRESSER FOOT	1
17	XXXXXX		PRESSER FOOT FINGER	1
18	211876	09-009803-85	SET PLATE/PRESSER FOOT	1
19	211877	09-009803-86	STOPPER/PRESSER FOOT	1
20	1333	09-009048-27	SCREW	1
21	403	09-009732-44	TAPE DISC ASSEMBLY	1
22	406	09-009732-47	FELT	1
23	405	09-009732-46	FIXING ROD	1
24	404	09-009732-45	TAPE DISC	1
25	4012	09-009612-25	SCREW	1
26	407	09-009732-48	COLLAR	1
27	408	09-009732-49	ADJUSTING SCREW	1
28	409	09-009732-50	SHAFT	1
29	4818	09-009732-56	NUT	1
30	410-JA	09-009813-01	BRACKET	1
31	4908	09-009732-57	SCREW	3
32	413	09-009732-52	TAPE INSERTING TOOL	1

504-4/350P1, 504-4/350P2
 514-4/351P1, 514-4/351P2

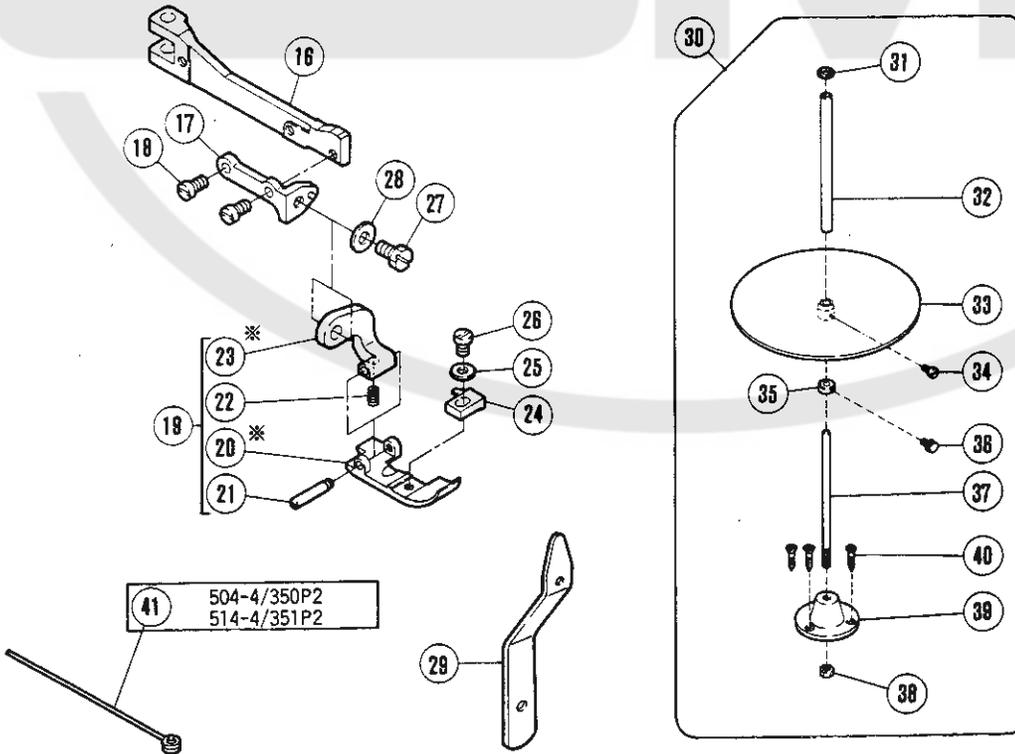
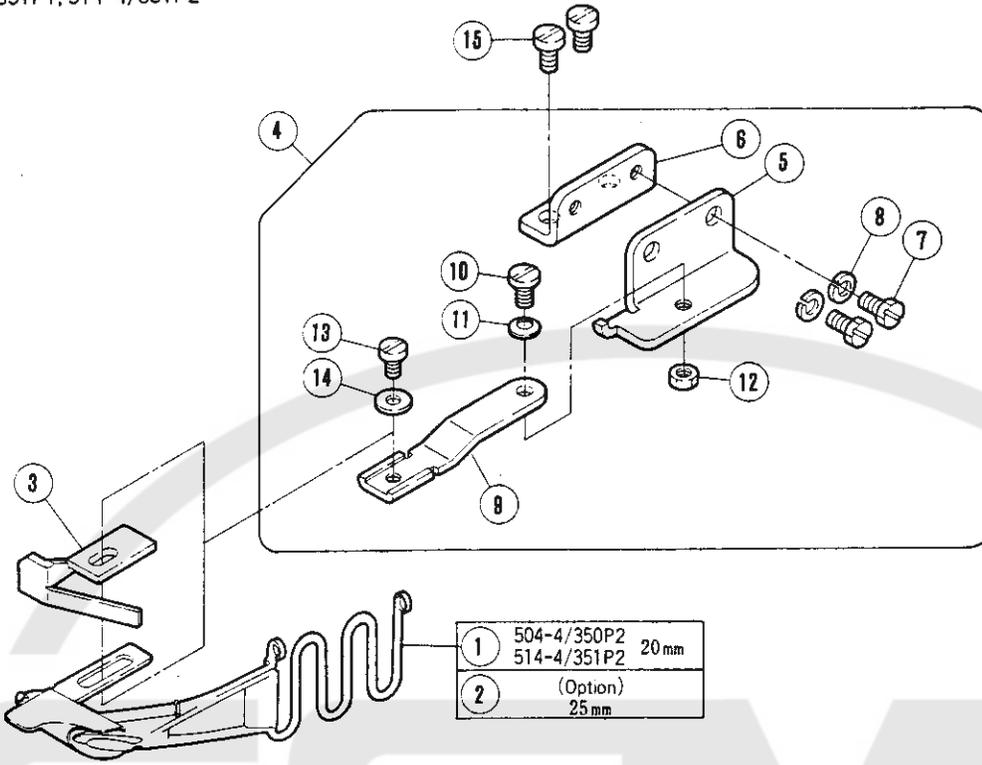

ATTACHMENT FOR PIPING (3)

PLEASE NOTE : 「XXXXXX」 is one of the gauge parts.
So please refer to pages 74~132 and
confirm the correct parts.

REF. NO.	PART NO.	PFAFF-NO.	NAME	QT.
1	211880	09-009733-41	BINDER (20)	1
2	211946	09-009733-47	BINDER (25)	1
3	211879	09-009733-40	EDGE GUIDE	1
4	209335	09-009839-89	GUIDE SET	1
5	204452	09-009602-12	BRACKET/EDGE GUIDE	1
6	204451	09-009602-11	BRACKET	1
7	2193	09-009053-37	SCREW	2
8	202286	09-009051-75	SPRING WASHER	2
9	209324	09-009833-93	HINGE	1
10	5184	09-009054-02	SCREW	1
11	201191	09-009050-43	SPRING	1
12	3044	09-009053-49	NUT	1
13	1202	09-009048-17	SCREW	1
14	167066	09-009601-53	WASHER	1
15	5117	09-009053-88	SCREW	2
16	209232	09-009806-87	PRESSER ARM	1
17	209230	09-009806-99	BRACKET	1
18	1196	09-009048-16	SCREW	2
19	209333-TA	09-009833-97	PRESSER FOOT COMPLETE	1
*20	211895-TA	09-009840-12	PRESSER FOOT BODY	1
21	211897-B	09-009840-13	PIN	1
22	211902	09-009840-14	SPRING	1
*23	209334	09-009833-98	HINGE	1
24	XXXXXX		PRESSER FOOT FINGER	1
25	202588	09-009052-70	WASHER	1
26	5089	09-009053-81	SCREW	1
27	2193	09-009053-37	SCREW	1
28	201185	09-009050-38	WASHER	1
29	211949	09-009733-48	CORD GUIDE PLATE	1
30	403	09-009732-44	TAPE DISC ASSEMBLY	1
31	406	09-009732-47	FELT	1
32	405	09-009732-46	FIXING ROD	1
33	404	09-009732-45	TAPE DISC	1
34	4012	09-009612-25	SCREW	1
35	407	09-009732-48	COLLAR	1
36	408	09-009732-49	ADJUSTING SCREW	1
37	409	09-009732-50	SHAFT	1
38	4818	09-009732-56	NUT	1
39	410-JA	09-009813-01	BRACKET	1
40	4908	09-009732-57	SCREW	3
41	413	09-009732-52	TAPE INSERTING TOOL	1

Notice) Parts with mark * are not for sale.

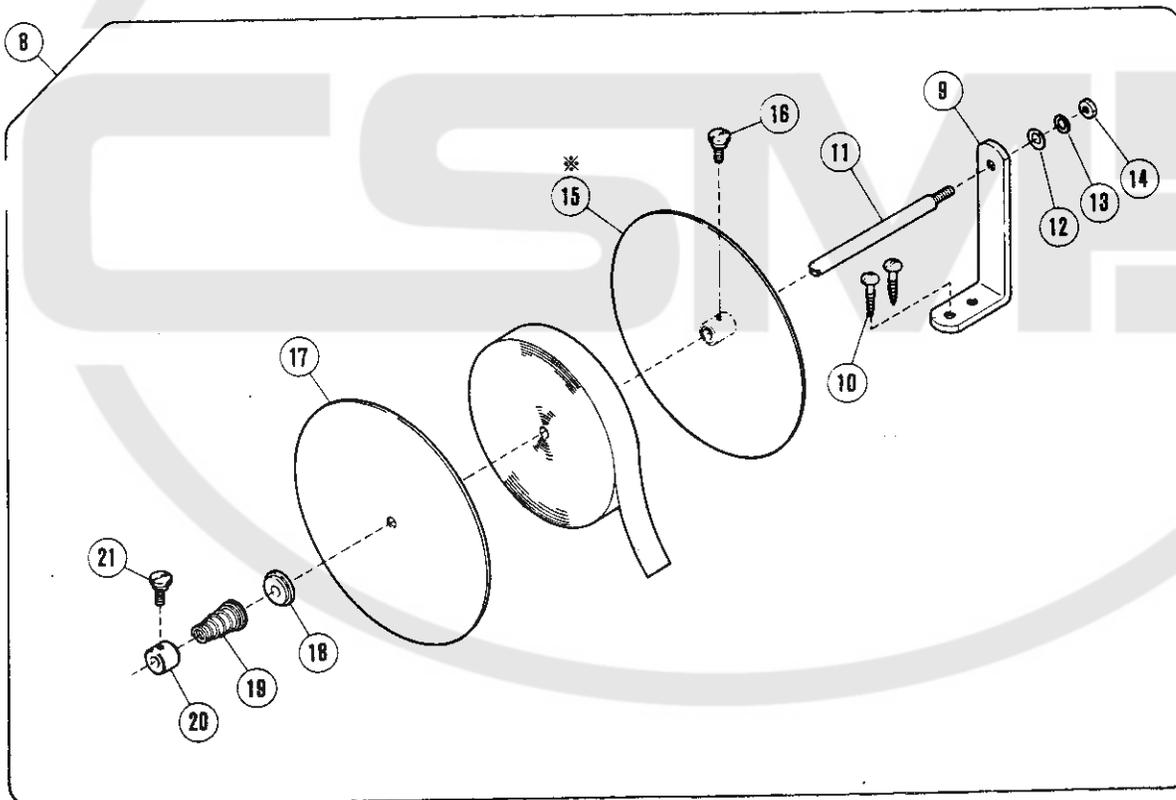
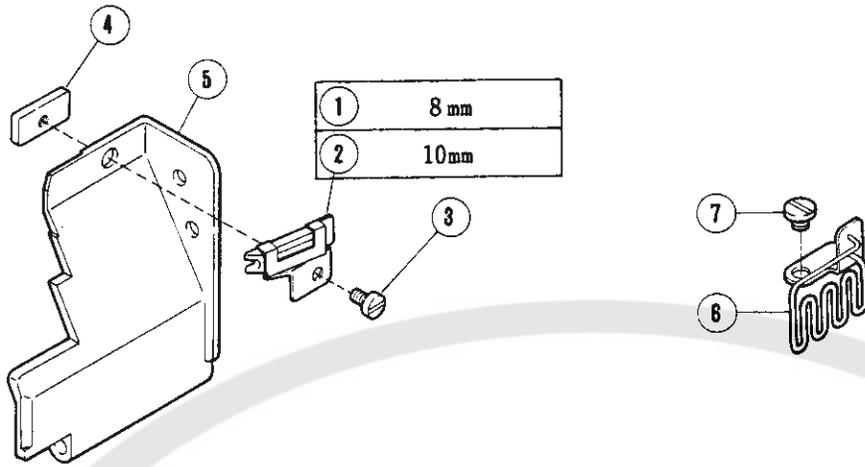

ATTACHING FOR TAPE

REF. NO.	PART NO.	PFAFF-NO.	NAME	QT.
1	208994	09-009803-58	BINDER (8)	1
2	209200	09-009803-59	BINDER (10)	1
3	1216	09-009048-20	SCREW	1
4	208997	09-009803-60	BINDER GUIDE	1
5	209000	09-009833-80	FRONT COVER (LEFT)	1
6	209206	09-009833-81	TAPE GUIDE	1
7	2905	09-009823-33	SCREW	1
8	337	09-009803-63	TAPE DISC ASSEMBLY	1
9	344	09-009803-64	BRACKET	1
10	4911	09-009803-65	SCREW	2
11	341	09-009803-66	ROD	1
12	189	09-009803-67	WASHER	1
13	303067	12-501170-45	SPRING WASHER	1
14	4805	09-400065-00	NUT	1
*15	338	09-009803-68	TAPE DISC	1
16	339	09-009803-74	SCREW	1
17	340	09-009803-70	TAPE DISC COVER	1
18	467	09-009803-71	SPRING SEAT	1
19	343	09-009803-72	SPRING	1
20	468	09-009803-73	COLLAR	1
21	339	09-009803-74	SCREW	1

Notice) Parts with mark ※ are not for sale.

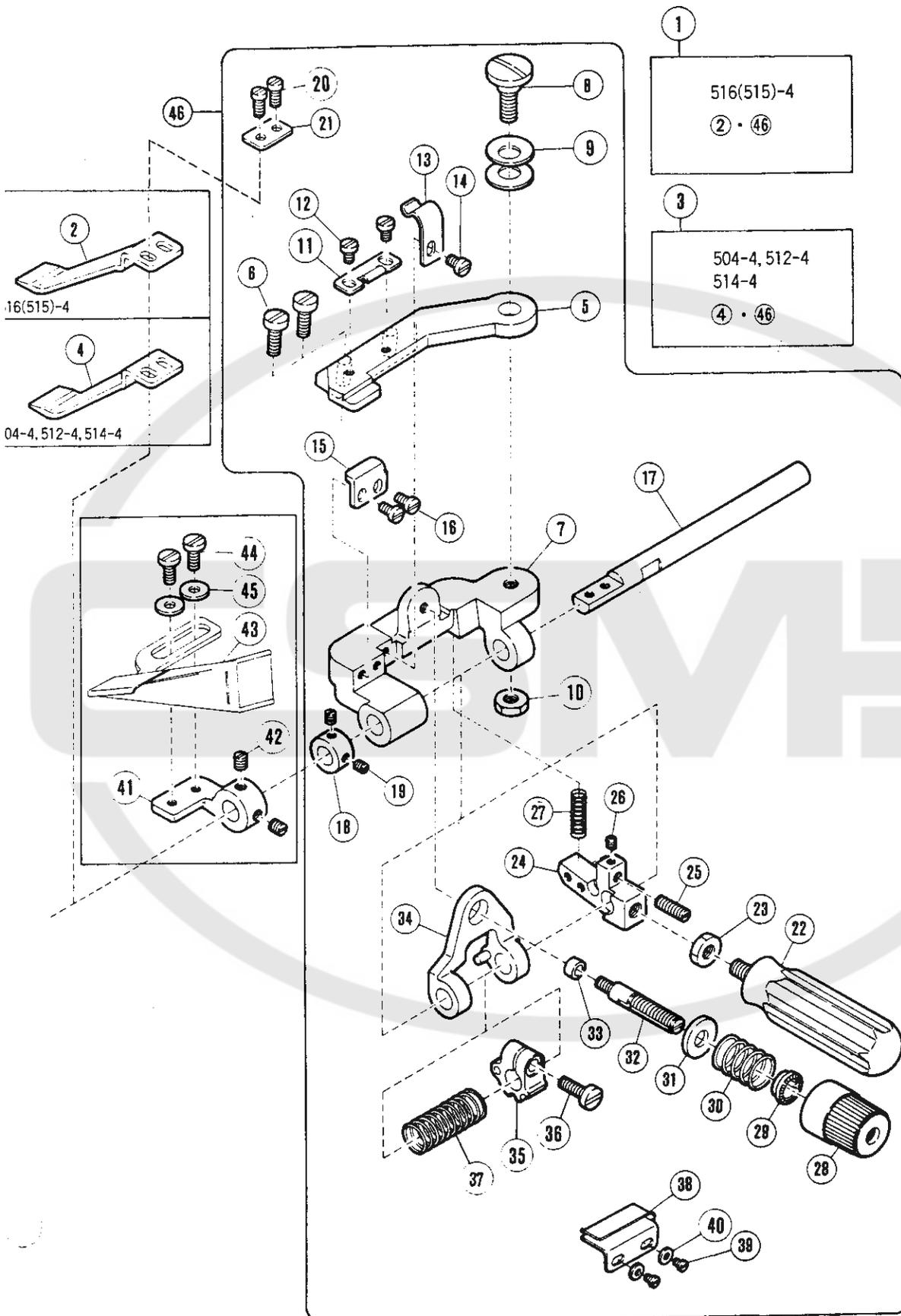

ATTACHMENT FOR SHIRRING

REF. NO.	PART NO.	PFAFF-NO.	NAME	QT.
1	208658	09-009800-17	SHIRRING ATTACHMENT COMPLETE	1
2	210953	09-009800-65	BLADE	1
3	208659	09-009819-34	SHIRRING ATTACHMENT COMPLETE	1
4	210954	09-009618-76	BLADE	1
5	208660	09-009800-18	BRACKET	1
6	5152	09-009053-99	SCREW	2
7	210936	09-009618-62	BRACKET	1
8	5513	09-009618-58	SCREW	1
9	204888	09-009602-49	SPRING	2
10	5104	09-009600-23	NUT	1
11	210947	09-009618-71	FLAT SPRING	1
12	1206	09-009048-19	SCREW	2
13	210946	09-009618-70	FLAT SPRING	1
14	1206	09-009048-19	SCREW	1
15	210945	09-009618-69	STOPPER	1
16	5328	09-009071-11	SCREW	2
17	210937	09-009618-63	SHAFT	1
18	206225	09-009618-60	COLLAR	1
19	1457-1	09-009048-65	SCREW	2
20	5029	09-009053-59	SCREW	2
21	210955	09-009618-77	WASHER	1
22	210948	09-009618-73	LEVER	1
23	5104	09-009600-23	NUT	1
24	211614	09-009800-69	BRACKET	1
25	1435	09-009048-63	SCREW	1
26	5292	09-009064-89	SCREW	1
27	210952	09-009618-75	SPRING	1
28	208447	09-009813-81	POST NUT	1
29	208448	09-009607-59	SPRING BUSHING	1
30	210940	09-009618-66	SPRING	1
31	204091	09-009055-59	WASHER	1
32	5082A	09-009053-74	SCREW STUD	1
33	210944	09-009618-68	WASHER	1
34	211613	09-009800-68	GUIDE	1
35	210938	09-009618-64	LATCH	1
36	5118	09-009053-89	SCREW	1
37	210939	09-009618-65	SPRING	1
38	205091	09-009067-64	SHIRRING EDGE GUIDE	1
39	1234	09-009048-23	SCREW	2
40	137906	09-009048-42	WASHER	2
41	210962	09-009618-79	BRACKET/BINDER	1
42	5210	09-009618-57	SCREW	2
43				1
44	1202	09-009048-17	SCREW	2
45	167066	09-009601-53	WASHER	2
46	209371	09-009819-47	SHIRRING DEVICE	1

Fabric Edge Guide

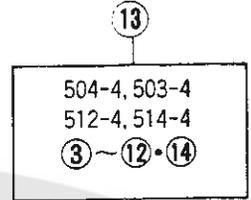
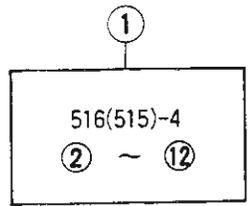
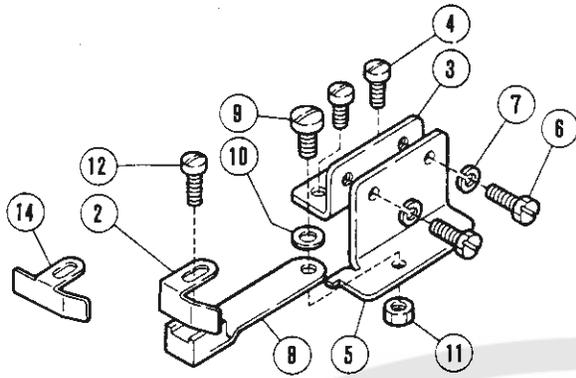

Cloth Guide

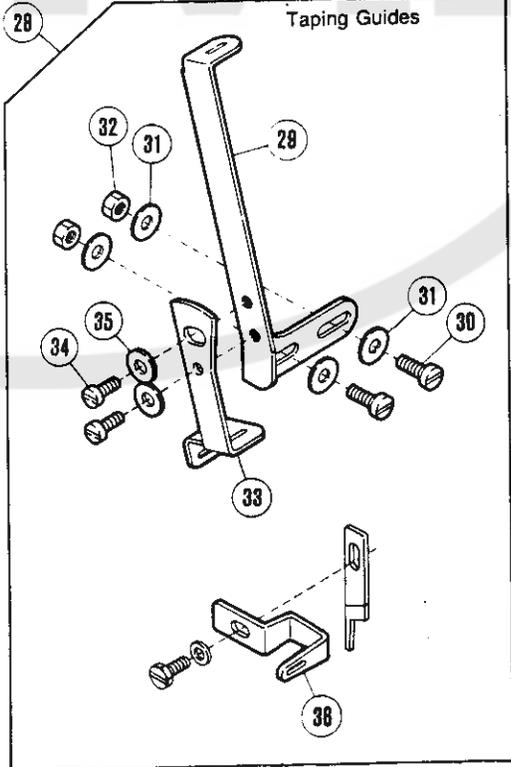
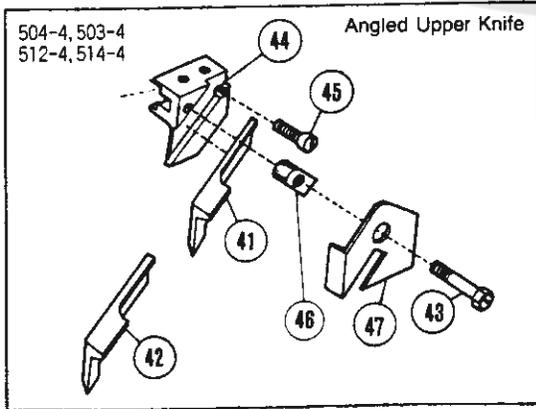
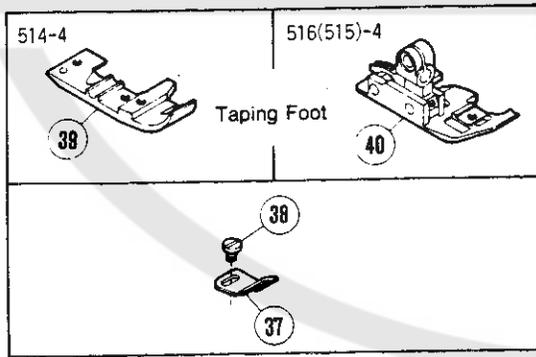
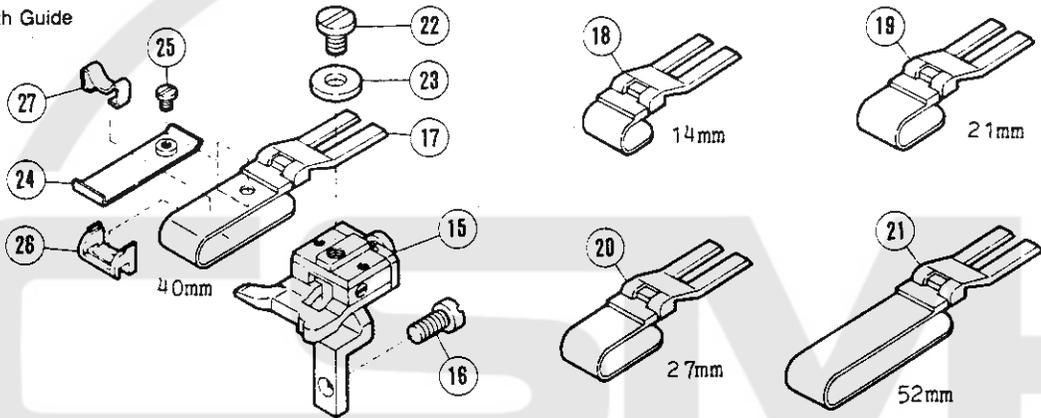

ATTACHMENT

REF. NO.	PART NO.	PFAFF-NO.	NAME	QT.
1	204449	09-009607-78	EDGE GUIDE COMPLETE	1
2	201233A	09-009065-31	EDGE GUIDE	1
3	204451	09-009602-11	BRACKET	1
4	5117	09-009053-88	SCREW	2
5	204452	09-009602-12	BRACKET/EDGE GUIDE	1
6	2193	09-009053-37	SCREW	2
7	202286	09-009051-75	SPRING WASHER	2
8	201485	09-009065-43	BRACKET/EDGE GUIDE	1
9	5184	09-009054-02	SCREW	1
10	201191	09-009050-43	SPRING	1
11	3044	09-009053-49	NUT	1
12	1202	09-009048-17	SCREW	1
13	204896	09-009070-16	BRACKET COMPLETE/EDGE GUIDE	1
14	204667	09-009068-19	EDGE GUIDE	1
15	204760A	09-009603-53	WELT GUIDE HOLDER	1
16	1189	09-009054-63	SCREW	1
17	201211C91	09-009819-99	FOLDER COMPLETE (40MM)	1
18	205457A91	09-009826-67	FOLDER COMPLETE (14MM)	1
19	205678A91	09-009823-16	FOLDER COMPLETE (21MM)	1
20	205679A91	09-009823-17	FOLDER COMPLETE (27MM)	1
21	205456A91	09-009823-15	FOLDER COMPLETE (52MM)	1
22	2905	09-009823-33	SCREW	1
23	137142	09-009048-30	WASHER	1
24	205835	09-009800-07	AUXILIARY PLATE	1
25	5299	09-009067-14	SCREW	1
26	303312A	09-009617-99	REGULATOR	1
27	303313	09-009618-00	FLAT SPRING	1
28	209402-91	09-009840-00	TAPE GUIDE ASSEMBLY	1
29	208915	09-009800-30	TAPE GUIDE (UPPER)	1
30	1175-3	09-009048-14	SCREW	2
31	137906	09-009048-42	WASHER	4
32	3091	09-009053-50	NUT	2
33	208916	09-009800-31	TAPE GUIDE (LOWER)	1
34	1216	09-009048-20	SCREW	2
35	137906	09-009048-42	WASHER	2
36	205319	09-009603-47	TAPE TAKEUP	1
37	208735	09-009800-22	FABRIC GURAD	1
38	1333	09-009048-27	SCREW	1
39	208730	09-009802-81	PRESSER FOOT	1
40	303688	09-009800-70	PRESSER FOOT	1
41	204152	09-009065-29	UPPER KNIFE	1
42	204835	09-009071-09	UPPER KNIFE	1
43	5371	09-009603-27	SCREW	1
44	204830	09-009603-28	UPPER KNIFE CLAMP	1
45	5142	09-009053-94	SCREW	1
46	204155	09-009065-33	GIB	1
47	204156	09-009064-22	WASTE GUARD	1

2	•	41	516(515)-4
32	•	41	504-4, 512-4 514-4

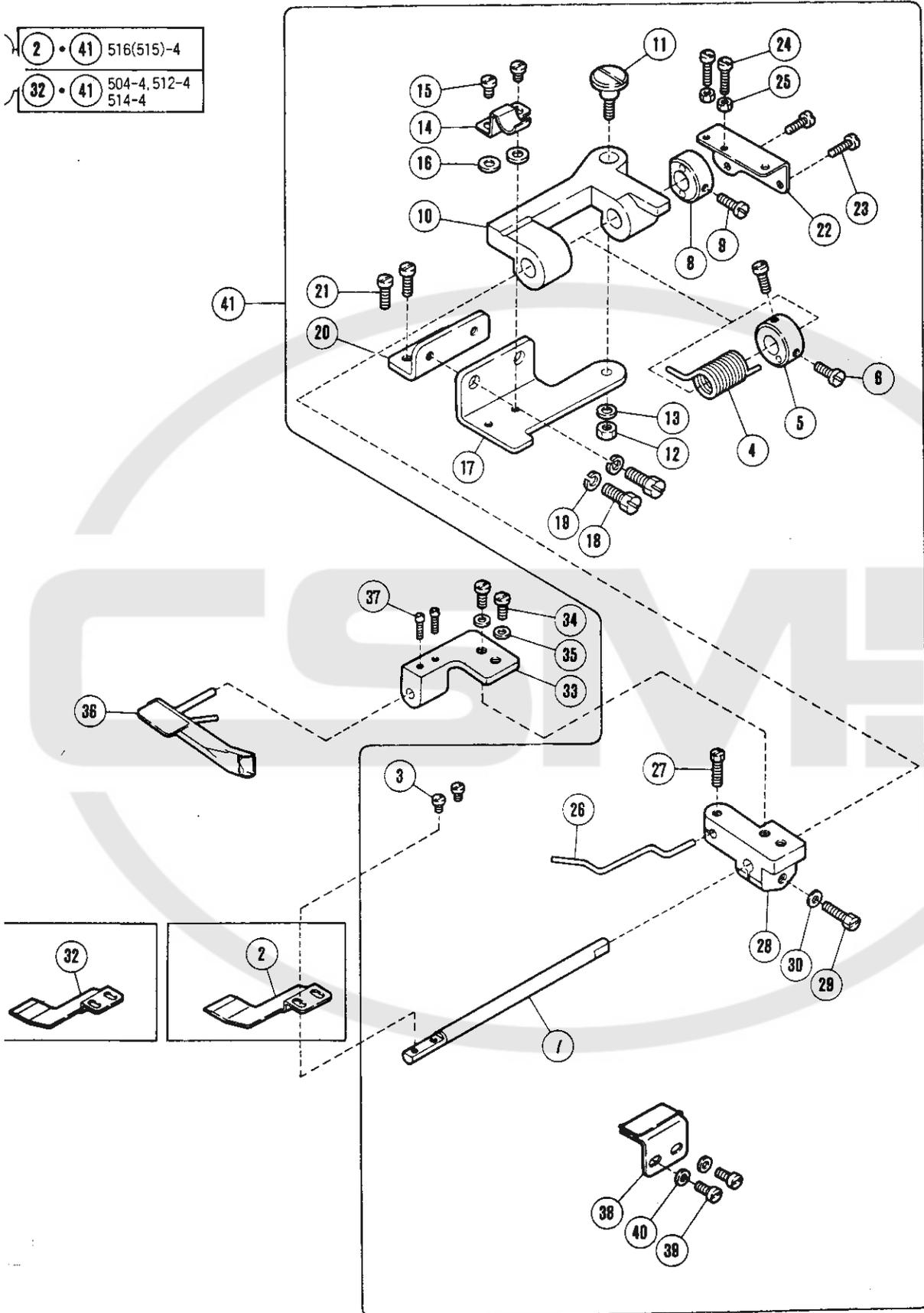

ATTACHMENT FOR SHIRRING (OPTION)

REF. NO.	PART NO.	PFAFF-NO.	NAME	QT.
1	204670	09-009067-65	SHIRRING ATTACHMENT COMPLETE	1
2	205064	09-009067-66	SHIRRING BLADE	1
3	5227	09-009068-73	SCREW	2
4	205065	09-009603-38	SPRING	1
5	205066	09-009603-39	COLLAR	1
6	5064	09-009053-66	SCREW	2
7	205067	09-009603-40	SHAFT	1
8	205068	09-009069-68	COLLAR	1
9	2213	09-009054-65	SCREW	1
10	205069	09-009603-41	BLOCK	1
11	5326	09-009070-24	SCREW	1
12	5137	09-009053-91	NUT	1
13	202286	09-009051-75	SPRING WASHER	1
14	205070	09-009069-15	FLAT SPRING	1
15	1229	09-009048-22	SCREW	2
16	200183	09-009048-77	WASHER	2
17	204495	09-009602-14	PLATE	1
18	2193	09-009053-37	SCREW	2
19	202286	09-009051-75	SPRING WASHER	2
20	204451	09-009602-11	BRACKET	1
21	5117	09-009053-88	SCREW	2
22	205072	09-009069-24	LEVER/PRESSER FOOT	1
23	5117	09-009053-88	SCREW	2
24	1170	09-009054-61	SCREW	2
25	3091	09-009053-50	NUT	2
26	204592	09-009069-14	LIFTER	1
27	5118	09-009053-89	SCREW	1
28	205104	09-009069-13	BLOCK	1
29	5276	09-009601-09	SCREW	1
30	204585	09-009602-15	WASHER	1
31	204882	09-009069-10	SHIRRING ATTACHMENT COMPLETE	1
32	205137	09-009069-11	PRESSER FOOT	1
33	205103	09-009603-42	BRACKET/BINDER	1
34	1175-3	09-009048-14	SCREW	2
35	167066	09-009601-53	WASHER	2
36				1
37	1170-1	09-009048-12	SCREW	2
38	205091	09-009067-64	SHIRRING EDGE GUIDE	1
39	1234	09-009048-23	SCREW	2
40	137906	09-009048-42	WASHER	2
41	204900	09-009833-44	SHIRRING DEVICE	1

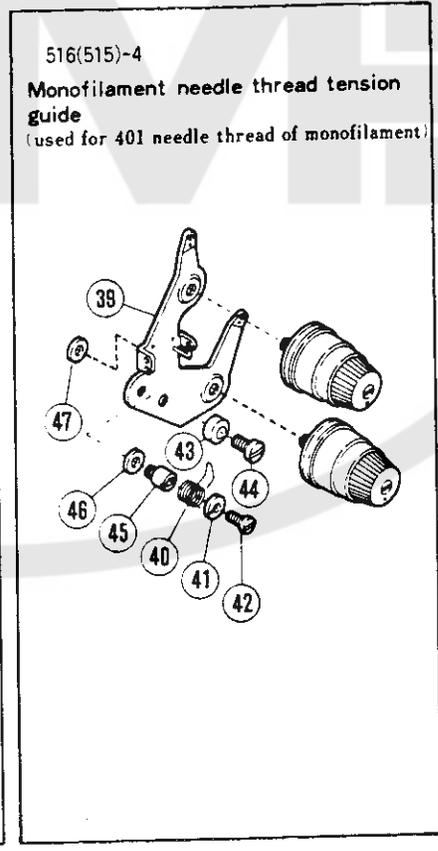
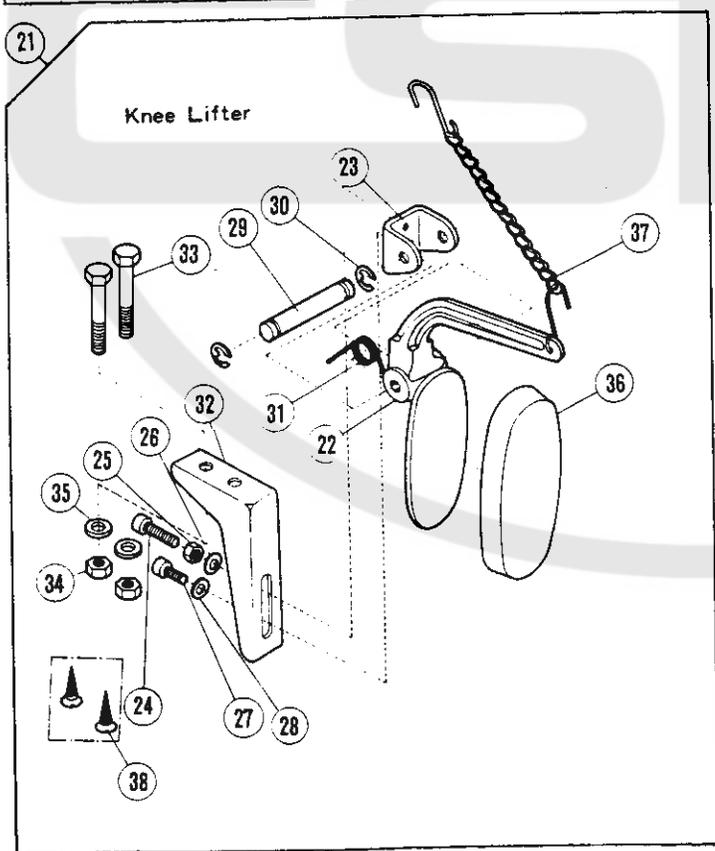
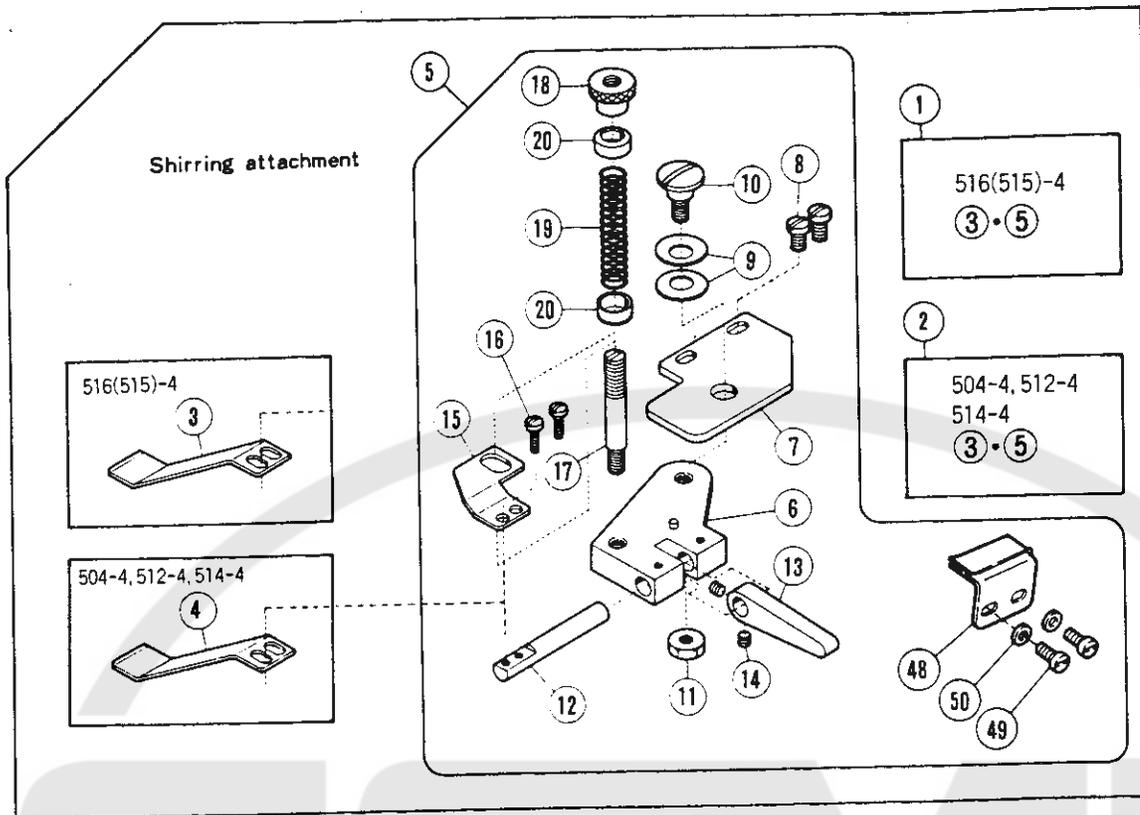

ATTACHMENT (OPTION)

REF. NO.	PART NO.	PFAFF-NO.	NAME	QT.
1	204897	09-009607-85	SHIRRING ATTACHMENT	1
2	204898	09-009603-34	SHIRRING ATTACHMENT	1
3	204966	09-009603-35	PRESSER FOOT	1
4	204885	09-009607-86	SHIRRING BLADE	1
5	209373	09-009839-98	SHIRRING DEVICE	1
6	204886	09-009602-47	BRACKET	1
7	204887	09-009602-48	BRACKET BASE	1
8	5117	09-009053-88	SCREW	2
9	204888	09-009602-49	SPRING	2
10	5380	09-009601-47	SCREW	1
11	5104	09-009600-23	NUT	1
12	204889	09-009602-50	SHIRRING BLADE SHAFT	1
13	204890	09-009602-51	LEVER	1
14	1459	09-009053-73	SCREW	2
15	204891	09-009602-52	BLADE GUIDE	1
16	1175-2	09-009048-13	SCREW	2
17	204892	09-009602-53	POST	1
18	204893	09-009602-54	THUMB NUT	1
19	204894	09-009603-14	SPRING	1
20	204895	09-009603-15	CUP	2
21	192	09-009600-04	KNEE CONTROLLER ASSEMBLY	1
22	193	09-009600-05	KNEE CONTROLLER	1
23	194	09-009600-06	HINGE	1
24	5183	09-009601-04	SCREW	1
25	3044	09-009053-49	NUT	1
26	137142	09-009048-30	WASHER	1
27	5118	09-009053-89	SCREW	1
28	137142	09-009048-30	WASHER	1
29	195	09-009600-07	PIN	1
30	202522	09-009052-03	RING	1
31	196	09-009600-08	SPRING	1
32	197	09-009600-09	BRACKET	1
33	5347	09-009833-38	SCREW	2
34	5348	09-009601-22	NUT	2
35	204585	09-009602-15	WASHER	2
36	198	09-009600-10	RUBBER PAD	1
37	199	09-00983-33	CHAIN	1
38	5341	09-009601-20	SCREW	2
39	208484	09-009608-23	THREAD TENSION BRACKET COM.	1
40	204960	09-009608-24	SPRING	1
41	204962	09-009608-25	NUT	1
42	2922	09-009065-38	SCREW	1
43	202683	09-009065-85	STOPPER	1
44	5117	09-009053-88	SCREW	1
45	204961	09-009608-26	STUD	1
46	202757A	09-009053-13	WASHER	1
47	205018	09-009833-46	WASHER	1
48	205091	09-009067-64	SHIRRING EDGE GUIDE	1
49	1234	09-009048-23	SCREW	2
50	137906	09-009048-42	WASHER	2

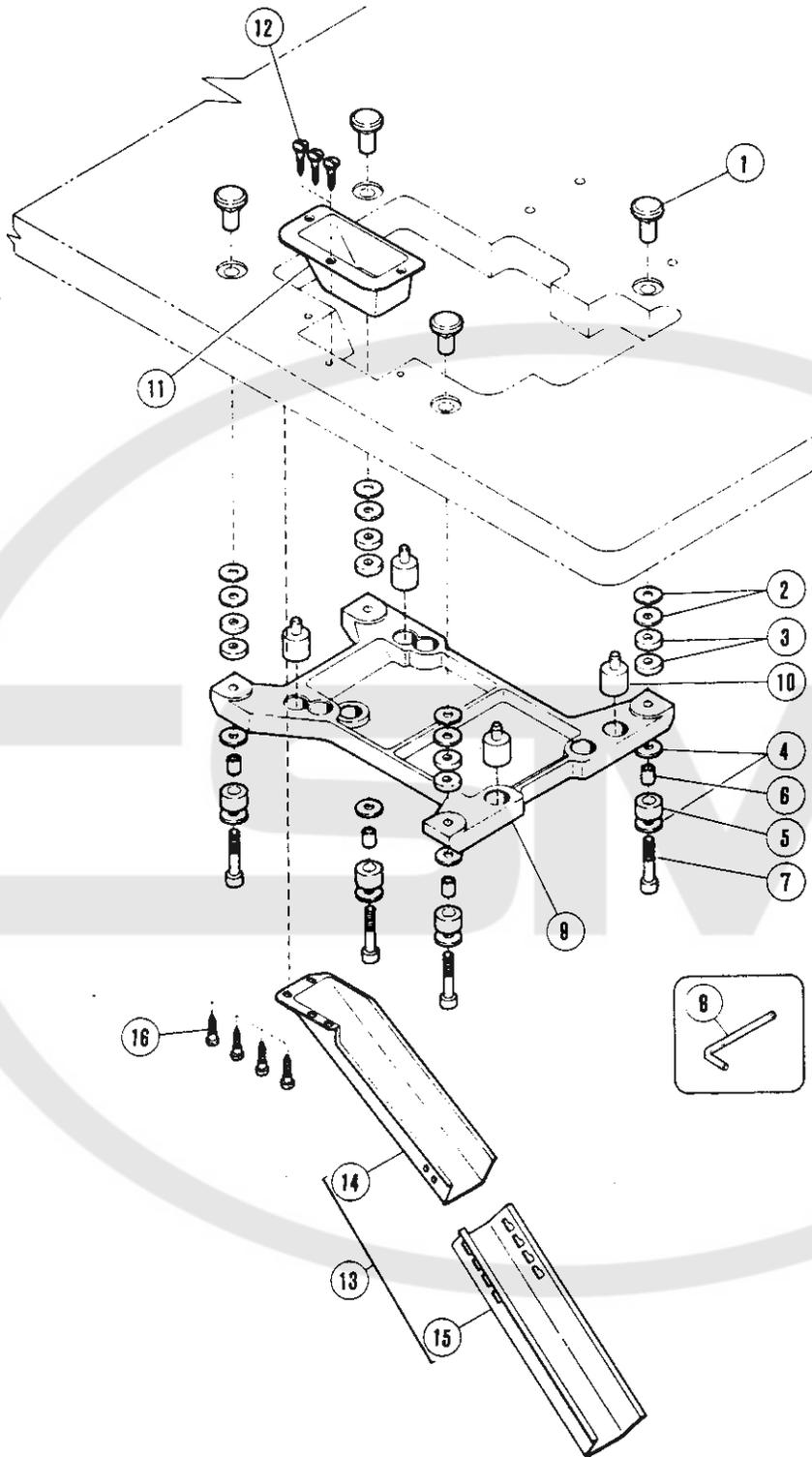

PARTS FOR SEMI-SUBMERGED INSTALLATION

REF. NO.	PART NO.	PFAFF-NO.	NAME	QT.
1	206336	09-009604-60	NUT	4
2	206337	09-009612-93	WASHER	8
3	205467	09-009603-76	SPACER	8
4	206337	09-009612-93	WASHER	8
5	205764	09-009612-87	CUSHION RUBBER	4
6	205765	09-009612-88	LINER	4
7	4512	09-400788-00	SCREW	4
8	272	09-009612-01	ALLEN KEY/6MM	1
9	205466	09-009603-75	MACHINE REST BOARD	1
10	205473	09-009823-67	CUSHION RUBBER	4
11	205470-JA	09-009815-05	WASTE CHUTE TOP	1
12	4904	09-009612-31	SCREW	3
13	9050	09-009815-93	WASTE CHUTE SET	1
14	205468-JA	09-009603-77	WASTE CHUTE TOP (A)	1
15	205469-JA	09-009603-78	WASTE CHUTE TOP (B)	1
16	4905	09-009612-32	SCREW	4



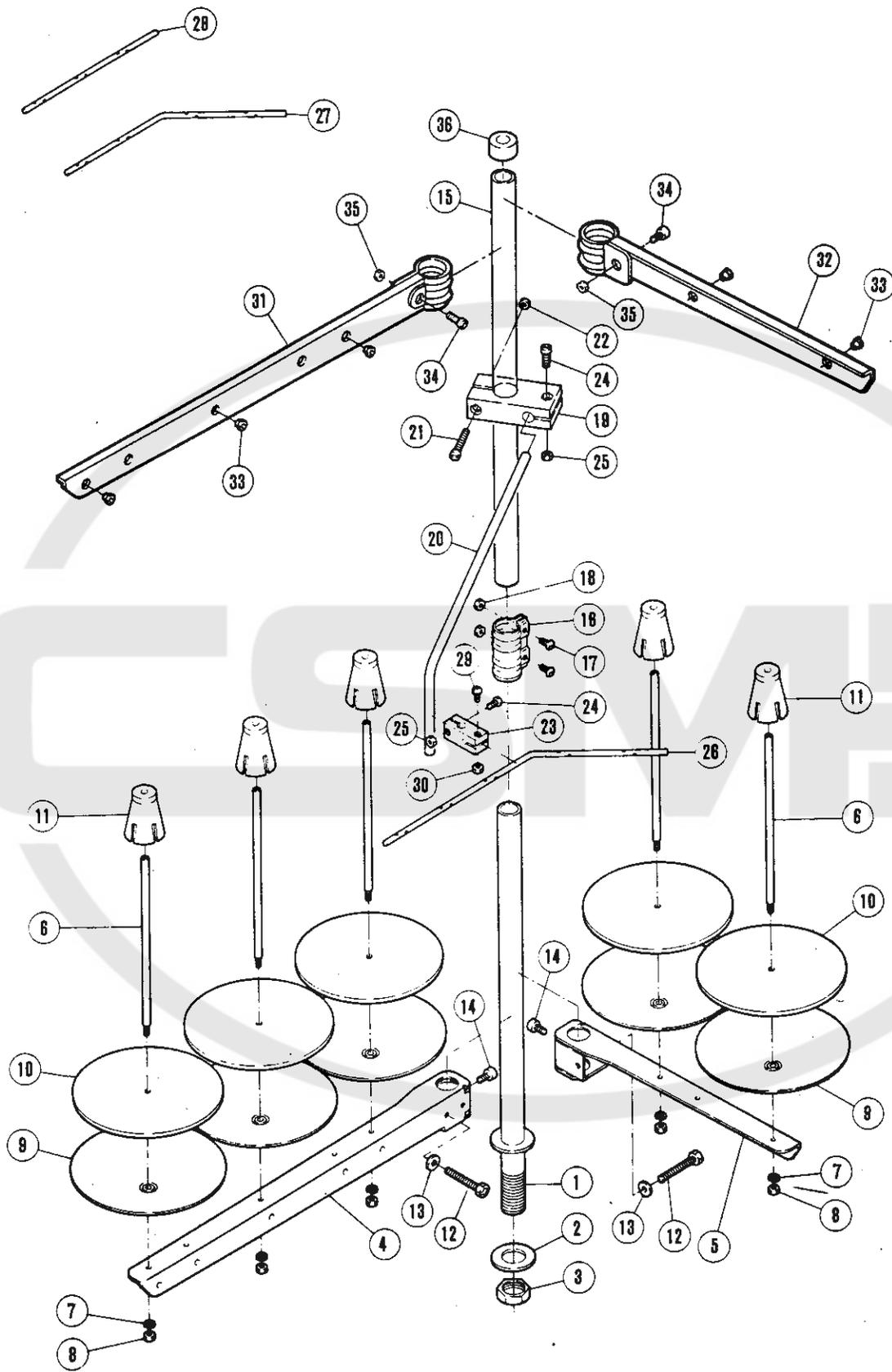

THREAD STAND

REF. NO.	PART NO.	PFAFF-NO.	NAME	SPOOLS: 3	4	5	QT
	486A9C	09-009612-04	THREAD STAND ASS. (5-SPOOLS)				1
	486B9C	09-400773-00	THREAD STAND ASS. (4-SPOOLS)		1		
	486C9C	09-400774-00	THREAD STAND ASS. (3-SPOOLS)	1			
1	503-CA	09-009815-12	THREAD STAND ROD (LOWER)	1	1		1
2	509	09-400784-00	WASHER	1	1		1
3	5476	09-009612-45	NUT	1	1		1
4	505-CA	09-400781-00	BRACKET	1			1
5	505ACA	09-400780-00	BRACKET		2		1
6	380A	09-009807-04	SPOOL PIN	3	4		5
7	201252	09-009050-73	SPRING WASHER	3	4		5
8	4803	09-009612-30	NUT	3	4		5
9	381-CA	09-009612-14	SPOOL TRAY	3	4		5
10	507	09-400783-00	CUSHION	3	4		5
11	382-CA	09-009612-15	SPOOL RETAINING FIN	3	4		5
12	7102	09-400792-00	SCREW	1	2		2
13	512	09-400785-00	WASHER	1	2		2
14	4022	09-400787-00	SCREW	1	2		2
15	502-CA	09-009815-14	THREAD STAND ROD (UPPER)	1	1		1
16	504-CA	09-400779-00	JOINT	1	1		1
17	4021	09-400786-00	SCREW	2	2		2
18	4805	09-400065-00	NUT	2	2		2
19	383-CA	09-009612-16	BRACKET	1	1		1
20	384	09-009612-17	THREAD GUIDE BAR ROD	1	1		1
21	4014	09-009612-27	SCREW	1	1		1
22	4803	09-009612-30	NUT	1	1		1
23	233-CA	09-009619-24	HOLDER	1	1		1
24	4012	09-009612-25	SCREW	2	2		2
25	4803	09-009612-30	NUT	2	2		2
26	293A	09-400768-00	THREAD GUIDE BAR (5-SPOOLS)				1
27	293B	09-400769-00	THREAD GUIDE BAR (4-SPOOLS)		1		
28	293C	09-400770-00	THREAD GUIDE BAR (3-SPOOLS)	1			
29	4012	09-009612-25	SCREW	1	1		1
30	4803	09-009612-30	NUT	1	1		1
31	527-CA	09-009826-63	BRACKET	1			1
32	527ACA	09-009826-64	BRACKET		2		1
33	506	09-400782-00	THREAD GUIDE	3	4		5
34	4117	09-009826-65	SCREW	1	2		2
35	4805	09-400065-00	NUT	1	2		2
36	386	09-009612-19	ROD CAP	1	1		1

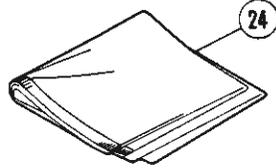
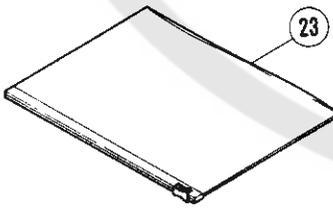
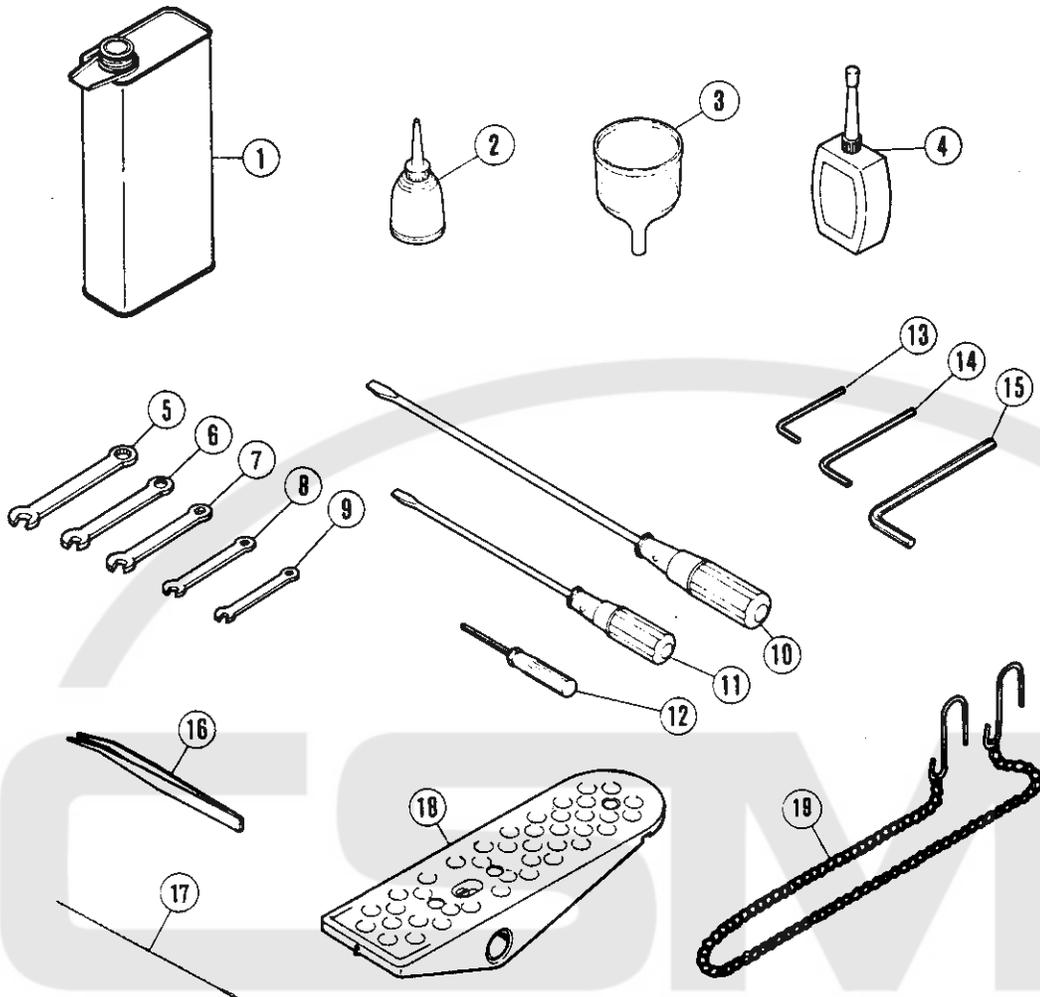

516(515)-4

※ 25	DCX27	# 11
※ 26	DCX27	# 14
※ 27	DCX27	# 16
※ 28	DCX27	# 18
※ 29	DCX27	# 19
※ 30	DCX27	# 9

504-4, 503-4, 505-4
512-4, 514-4

※ 25	DCX27	# 11
※ 26	DCX27	# 14
※ 27	DCX27	# 16
※ 28	DCX27	# 18
※ 30	DCX27	# 9
※ 31	DCX 3	# 9

ACCESSORIES

REF. NO.	PART NO.	PFAFF-NO.	NAME	QT.
1	452	09-009833-34	OIL CONTAINER/750CC	
2	485	09-400030-00	OILER	
3	484	09-400029-00	OIL FUNNEL	
4	178	09-009600-03	CONTAINER - SILICONE	
5	286	09-009054-17	WRENCH/9.5MM	
6	285	09-009048-26	WRENCH/8MM	
7	284	09-009048-25	WRENCH/7MM	
8	283	09-009048-24	WRENCH/6MM	
9	391	09-009800-01	WRENCH/5MM	
10	127	91-029007-91	SCREWDRIVER (LARGE)	
11	128	91-029480-91	SCREWDRIVER (MEDIUM)	
12	179	09-009071-00	ALLEN KEY DRIVER	
13	322	09-009815-06	ALLEN KEY/2.38MM	
14	182	99-631288-15	ALLEN KEY	
15	200	09-009815-07	ALLEN KEY/4.76MM	
16	131	09-009815-08	TWEEZERS	
17	153	09-009819-55	THREADING WIRE	
18	480	09-009815-09	PEDAL	
19	392	09-009734-77	CHAIN	
20	204161	09-009053-33	LOWER KNIFE	
21	201127	09-009054-43	LOWER KNIFE/THIN	
22	202295	09-009066-42	LOWER KNIFE/THICK	
23	482	09-400028-00	ACCESSORY BAG	
24	909	09-009612-22	DUST COVER	
*25	629B	09-009833-27	NEEDLE	
*26	630B	09-009833-28	NEEDLE	
*27	631B	09-009833-29	NEEDLE	
*28	647B	09-009833-31	NEEDLE	
*29	656B	09-009833-32	NEEDLE	
*30	642B	09-009833-30	NEEDLE	
*31	613B	09-009833-26	NEEDLE	

Notice) Parts with mark * are not for sale.

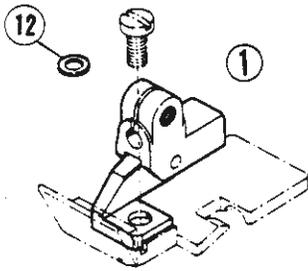

NG = Needle Gauge
 CD = Cord Diameter

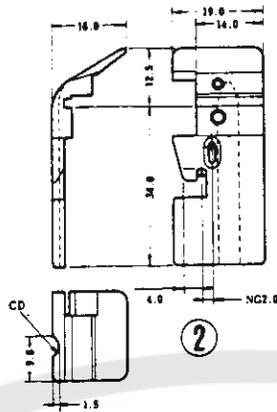

NG x CD	Part No.
2 x 3	204499
2 x 4	204500
2 x 5	204501

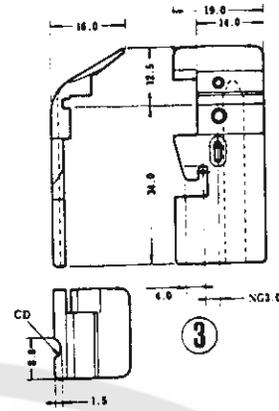

NG x CD	Part No.
3 x 3	204502
3 x 4	204503
3 x 5	204504

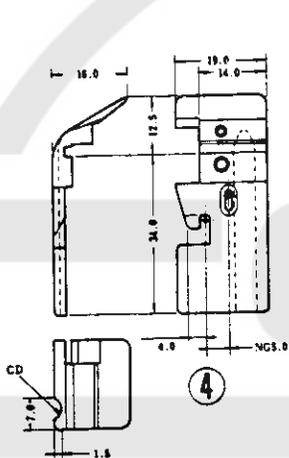

NG x CD	Part No.
5 x 3	204505
5 x 4	204506
5 x 5	204507

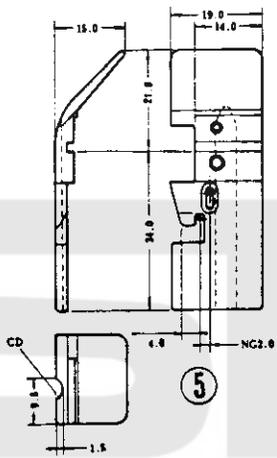

NG x CD	Part No.
2 x 3	204508
2 x 4	204509
2 x 5	204510

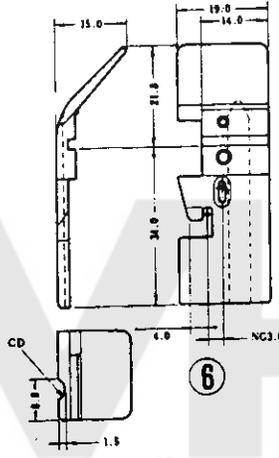

NG x CD	Part No.
3 x 3	204511
3 x 4	204512
3 x 5	204513

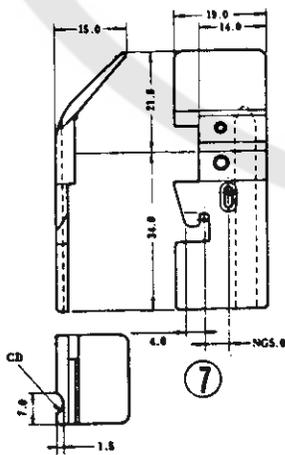

NG x CD	Part No.
5 x 3	204514
5 x 4	204515
5 x 5	204516

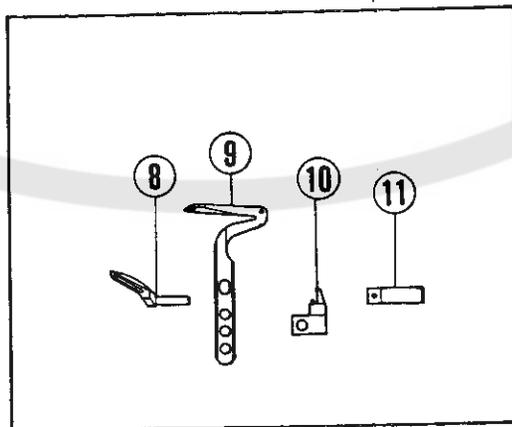

PIPING FOOT - OTHERS

REF. NO.	PART NO.	PFAFF-NO.	NAME	QT.
1	208554	09-009606-77	BRACKET COMPLETE	1
2	204499	09-009608-00	PIPING FOOT	1
2	204500	09-009608-01	PIPING FOOT	1
2	204501	09-009608-02	PIPING FOOT	1
3	204502	09-009608-03	PIPING FOOT	1
3	204503	09-009608-04	PIPING FOOT	1
3	204504	09-009608-05	PIPING FOOT	1
4	204505	09-009608-06	PIPING FOOT	1
4	204506	09-009608-07	PIPING FOOT	1
4	204507	09-009608-08	PIPING FOOT	1
5	204508	09-009608-09	PIPING FOOT	1
5	204509	09-009608-10	PIPING FOOT	1
5	204510	09-009608-11	PIPING FOOT	1
6	204511	09-009608-12	PIPING FOOT	1
6	204512	09-009608-13	PIPING FOOT	1
6	204513	09-009608-14	PIPING FOOT	1
7	204514	09-009608-15	PIPING FOOT	1
7	204515	09-009608-16	PIPING FOOT	1
7	204516	09-009608-17	PIPING FOOT	1
8	204990	09-009603-48	UPPER LOOPER	1
9	204991	09-009603-49	LOWER LOOPER	1
10	204906	09-009603-50	PRESSER FOOT FINGER	1
11	202281	09-009601-66	WELT GUIDE EXTENSION/TRICOT	1
12	202875	09-009601-76	WASHER	1

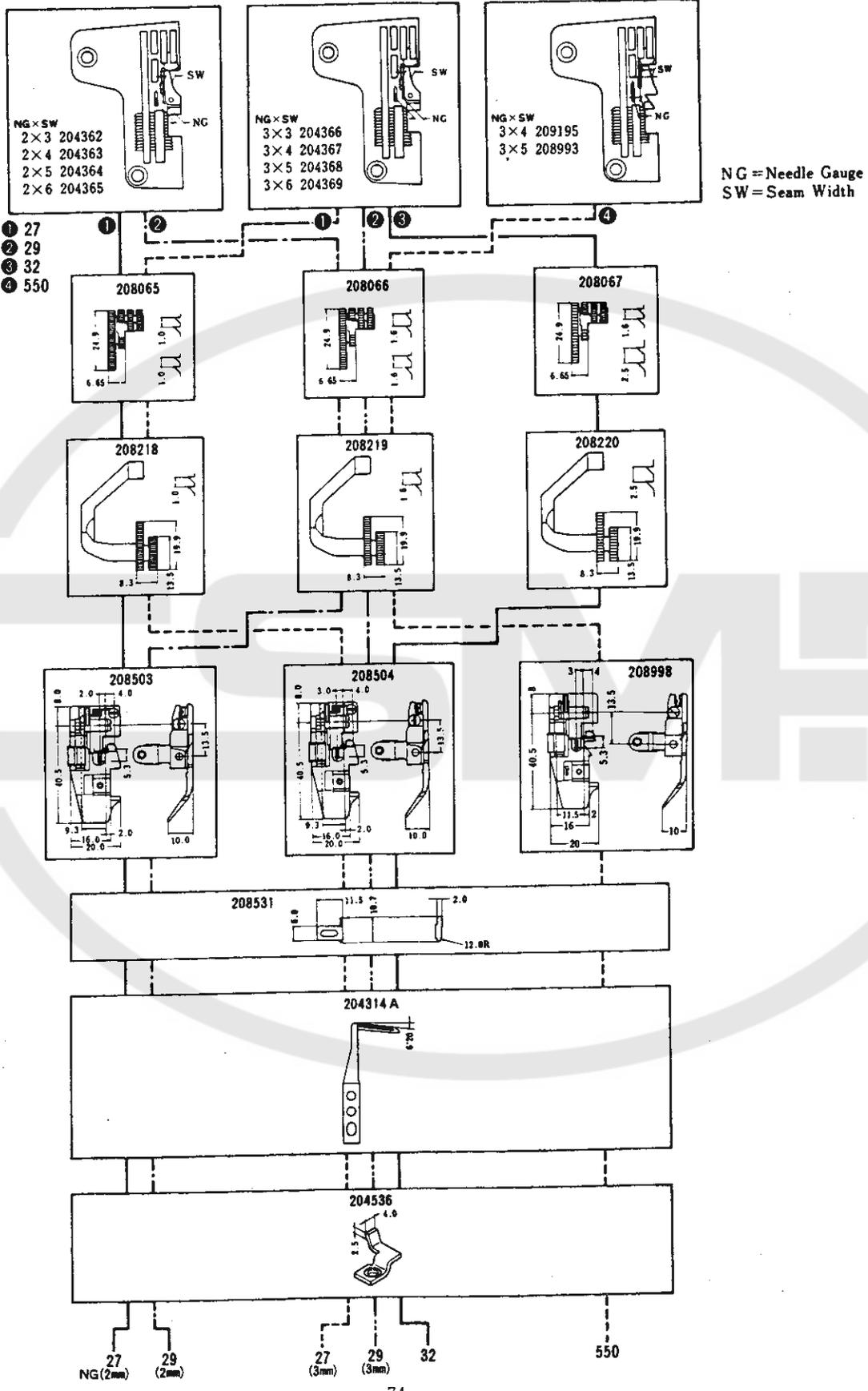

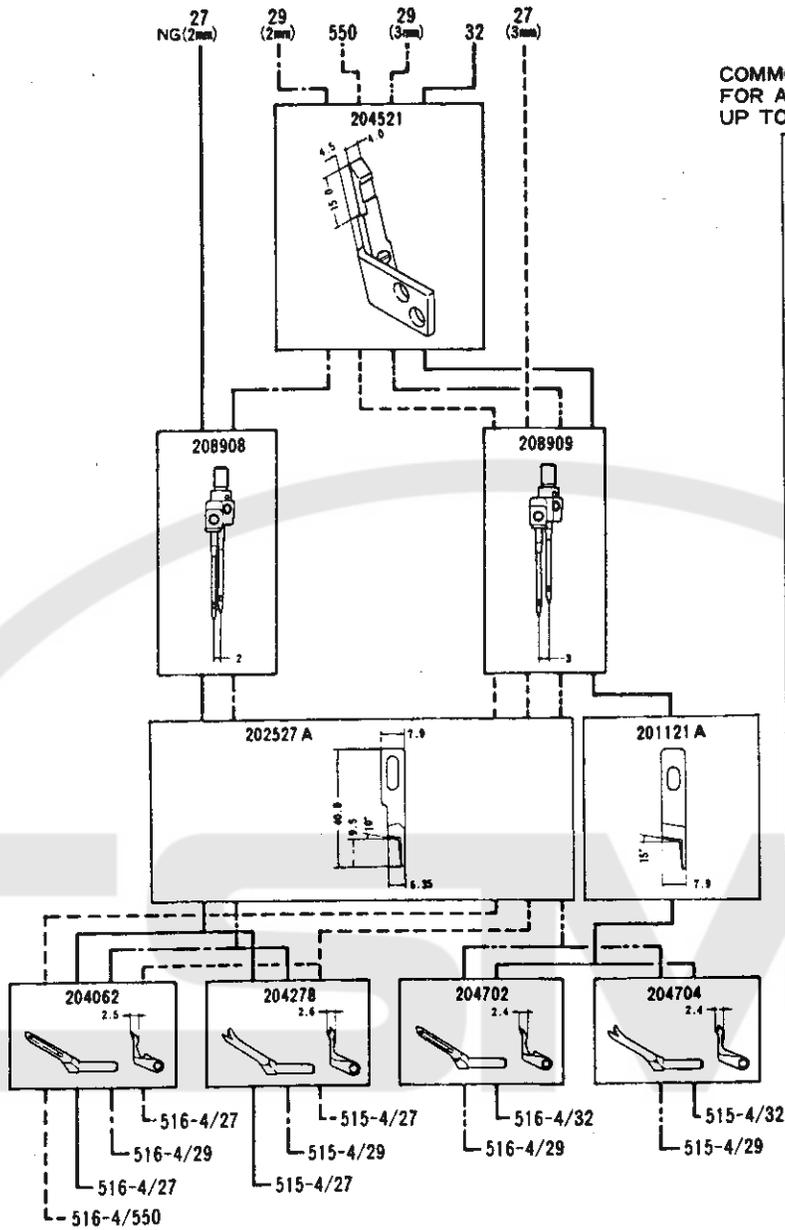

COMMON GAUGE PARTS
FOR ALL MACHINE TYPES
UP TO PAGE 89

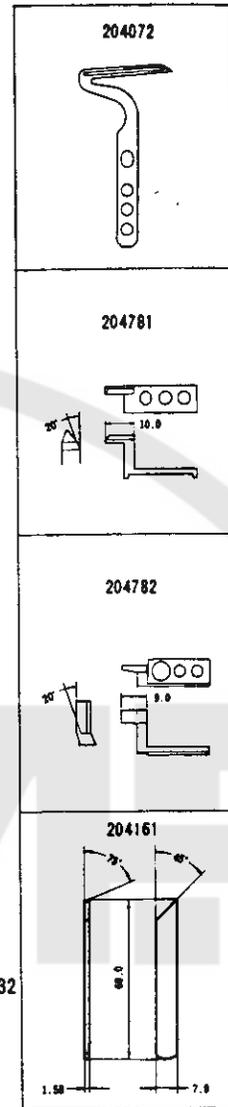

				MEMO	
516(515) -4/27	2	3,4,5,6	0.6~2		Fine tooth pitch makes this ideal for seaming on permapress fabrics, nylon linings etc.
	3	3,4,5,6	0.6~2		
516(515) -4/29	2	3,4,5,6	0.6~2		For general seaming on woven or knit fabrics such as slacks, pajamas, shirts, sweatpants etc.
	3	3,4,5,6	0.6~2		
516(515) -4/32	3	3,4,5,6	0.6~2		For seaming on heavyweight materials.
516-4/550	3	4,5	0.7~2		Fitted with a binding attachment to insert a tape inside seam. Ensures high quality results.

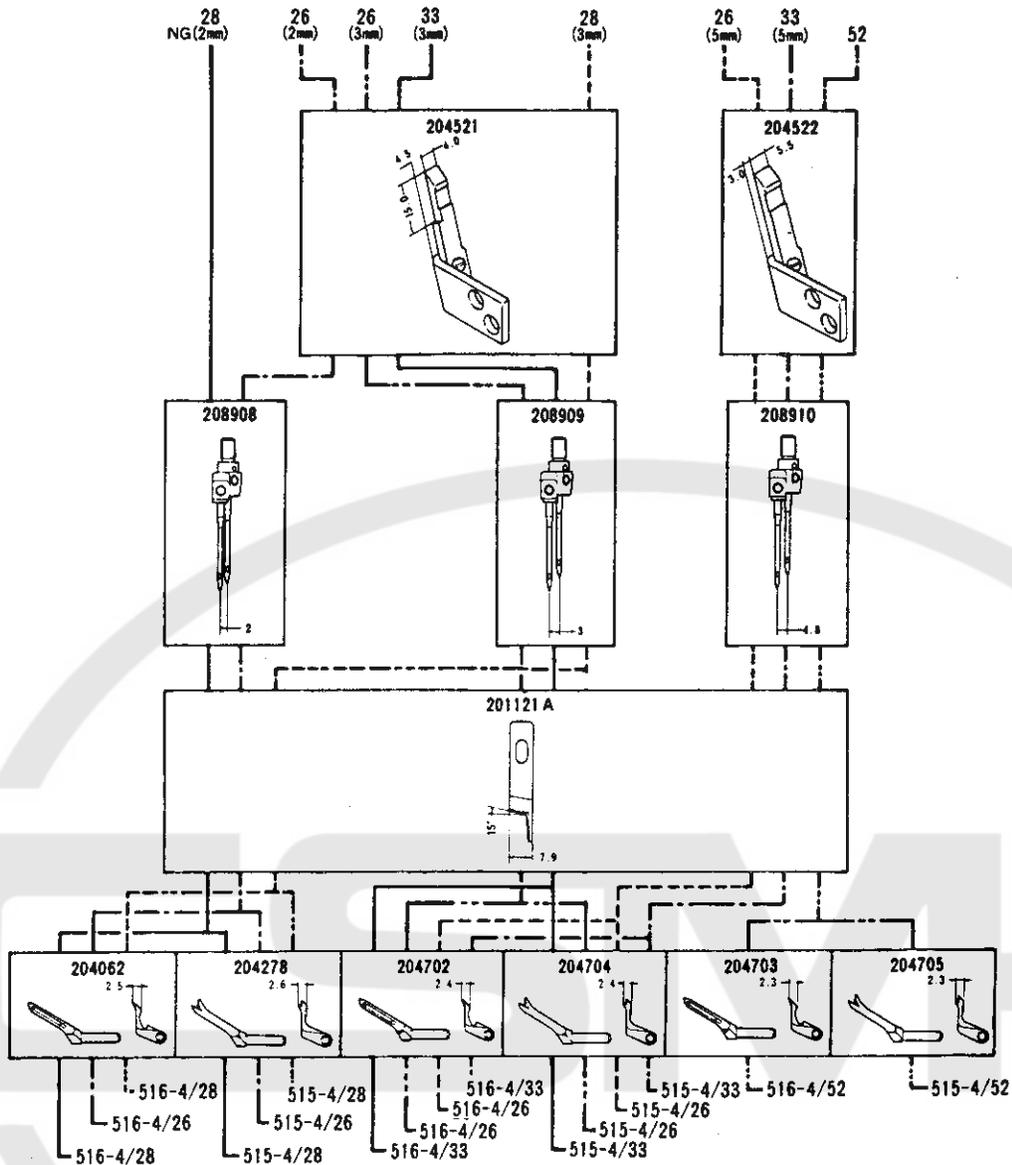

				MEMO	
516(515) -4/28	2	3, 4, 5, 6	0.6~2		Fine tooth pitch makes this ideal for seaming on permapress fabrics, nylon linings etc.
	3	3, 4, 5, 6	0.6~2		
516(515) -4/26	2	3, 4, 5, 6	0.6~2		For general seaming on woven or knit fabrics such as slacks, pajamas, shirts, sweatpants etc.
	3	3, 4, 5, 6	0.6~2		
	5	3, 4, 5, 6	0.6~2		
516(515) -4/33	3	3, 4, 5, 6	0.6~2		For seaming on heavyweight materials.
	5	3, 4, 5, 6	0.6~2		
516(515) -4/52	5	5, 6	0.6~2		Fitted with caterpillar foot for trouble-free seaming on jeans, workwear etc.

**GAUGE PARTS
CONSTRUCTION CHART**
Feed pattern : 3W(3-row wide)

516 (515) -4/37, 30, 31 (NG=2mm·3mm)

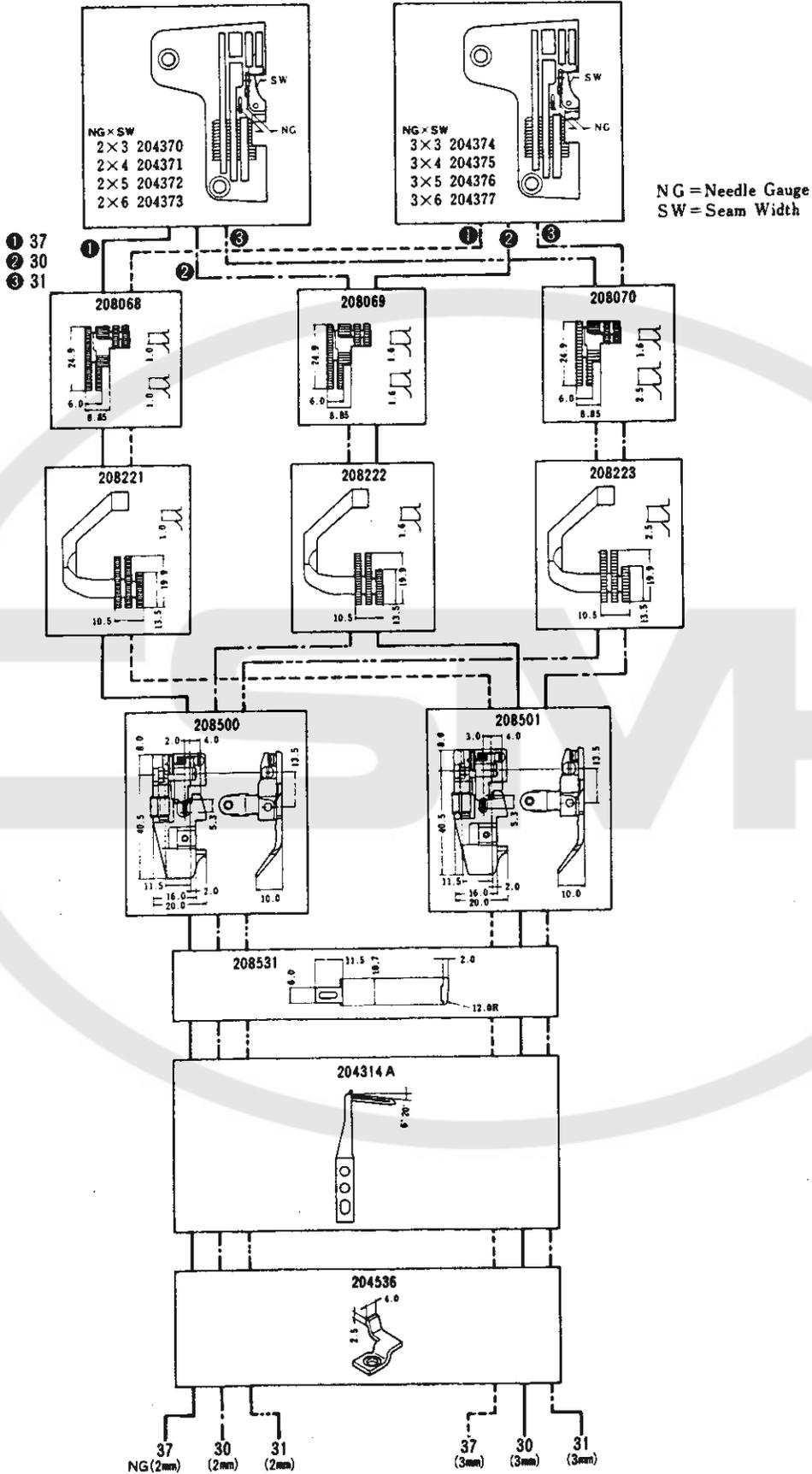

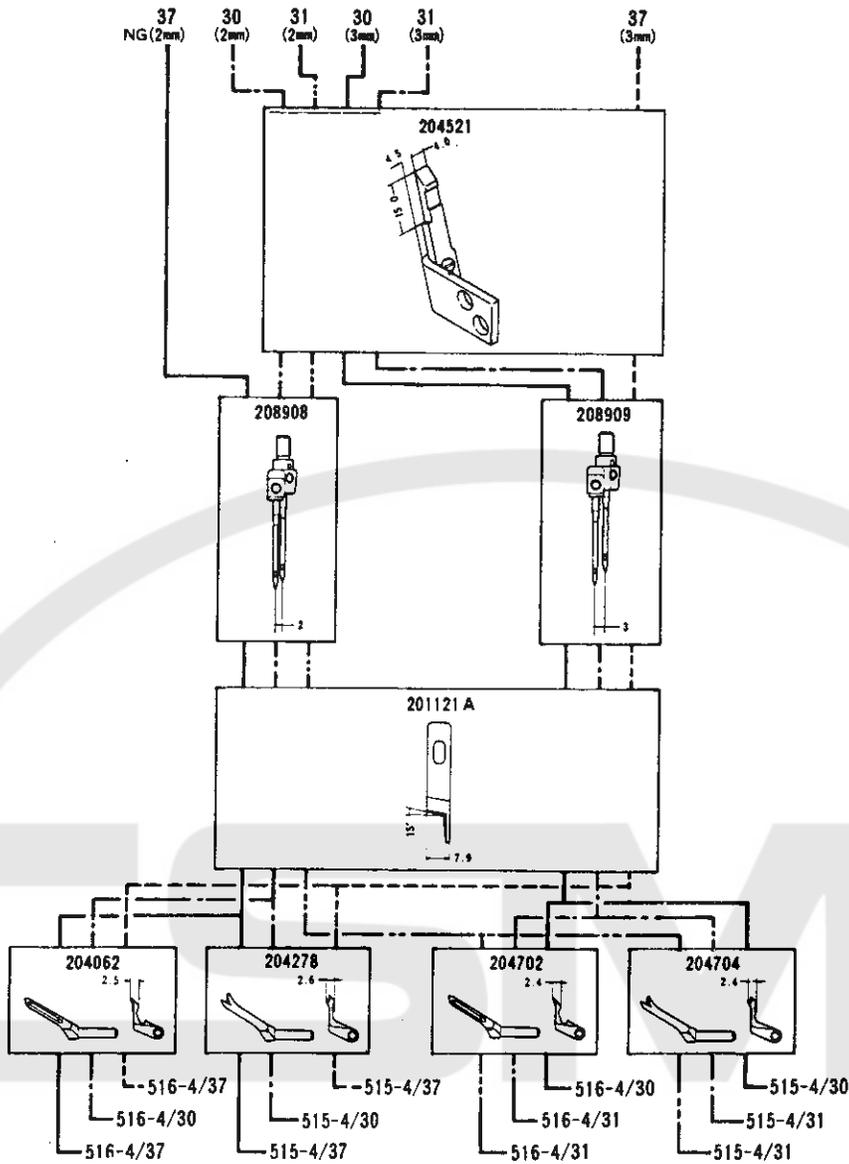

				MEMO	
516(515) -4/37	2	3, 4, 5, 6	0.6~2		Fine tooth pitch makes this ideal for seaming on permapress fabrics, nylon linings etc.
	3	3, 4, 5, 6	0.6~2		
516(515) -4/30	2	3, 4, 5, 6	0.6~2		For general seaming on woven or knit fabrics such as slacks, pajamas, shirts, sweatpants etc.
	3	3, 4, 5, 6	0.6~2		
516(515) -4/31	2	3, 4, 5, 6	0.6~2		For seaming on heavyweight materials.
	3	3, 4, 5, 6	0.6~2		

**GAUGE PARTS
CONSTRUCTION CHART**
Feed pattern : 3W(3-row wide)

516 (515) -4/30, 31 (NG=5mm)
516 (515) -4/51, 91

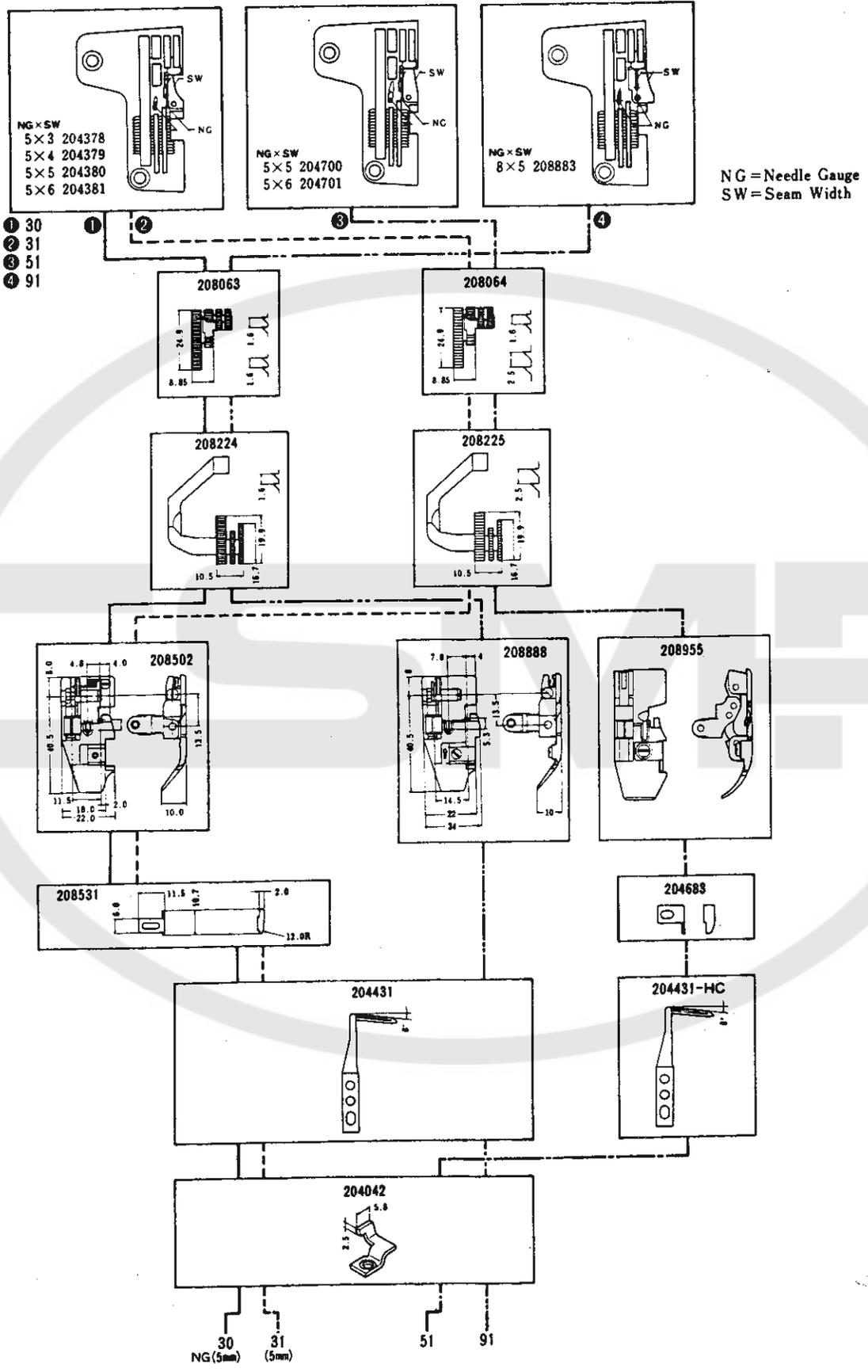

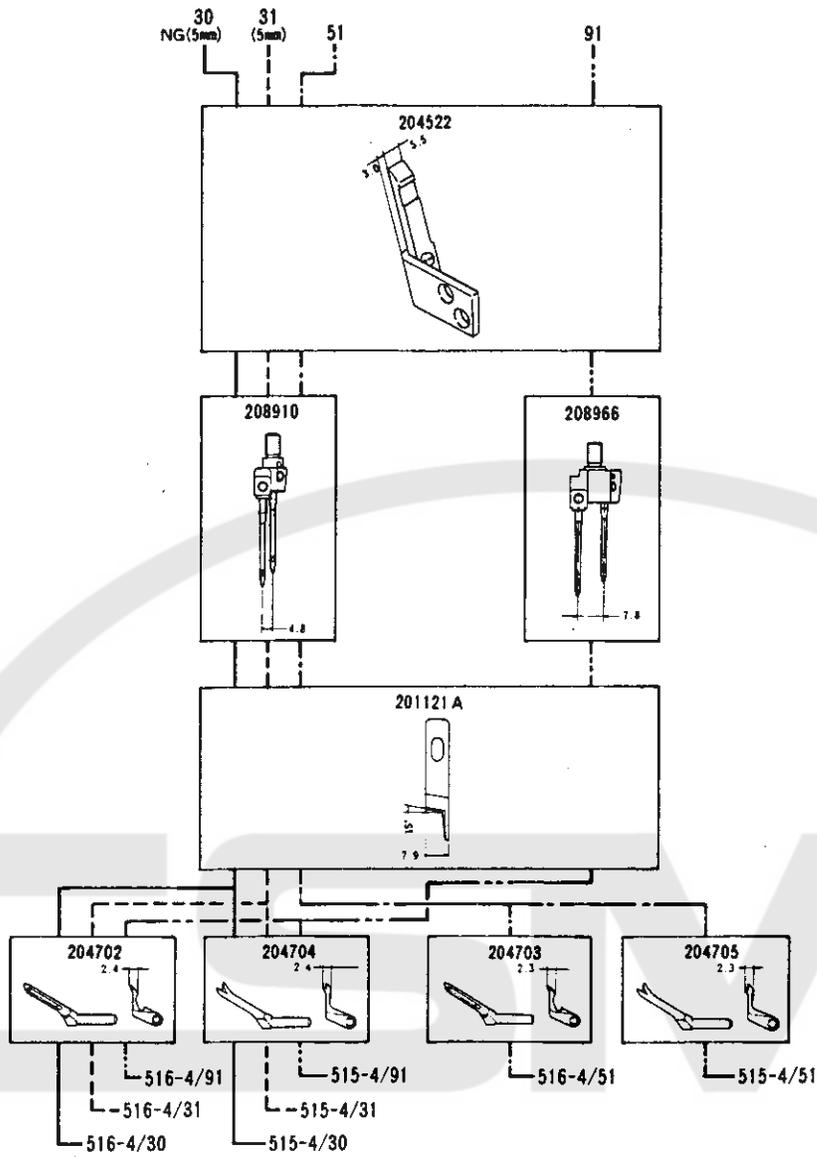

				MEMO	
516(515) -4/30	5	3, 4, 5, 6	0.6~2		For general seaming on woven or knit fabrics such as slacks, pajamas, shirts, sweatpants etc.
516(515) -4/31	5	3, 4, 5, 6	0.6~2		For seaming on heavyweight materials.
516(515) -4/51	5	5, 6	0.6~2		Fitted with caterpillar foot for trouble-free seaming on jeans, workwear etc.
516(515) -4/91	8	5	0.6~2		Extra wide needle gauge. Seaming on light to medium woven or knit fabrics such as blouse.

**GAUGE PARTS
CONSTRUCTION CHART**

Shirring machine models

516 (515) -4/38, 39

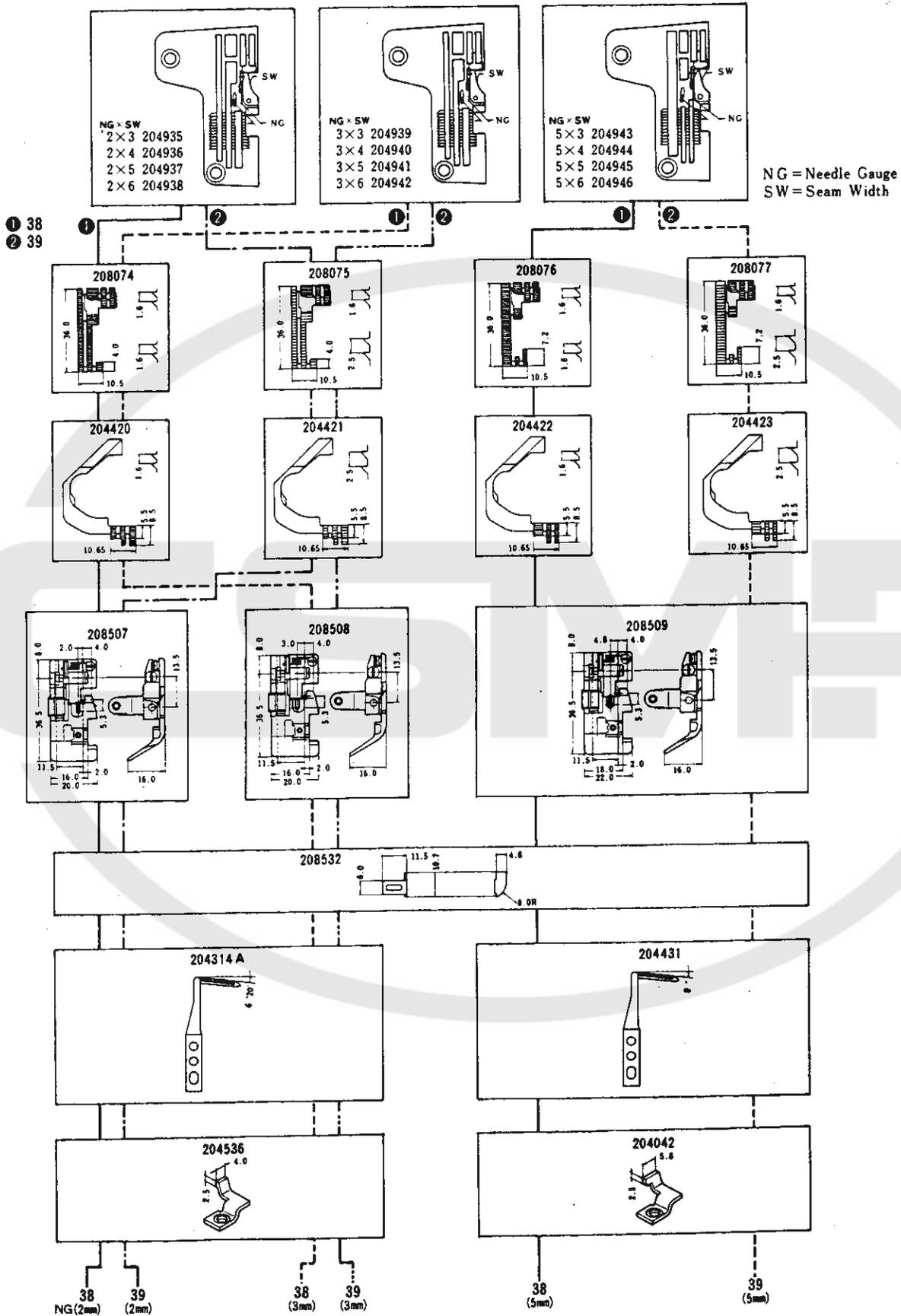

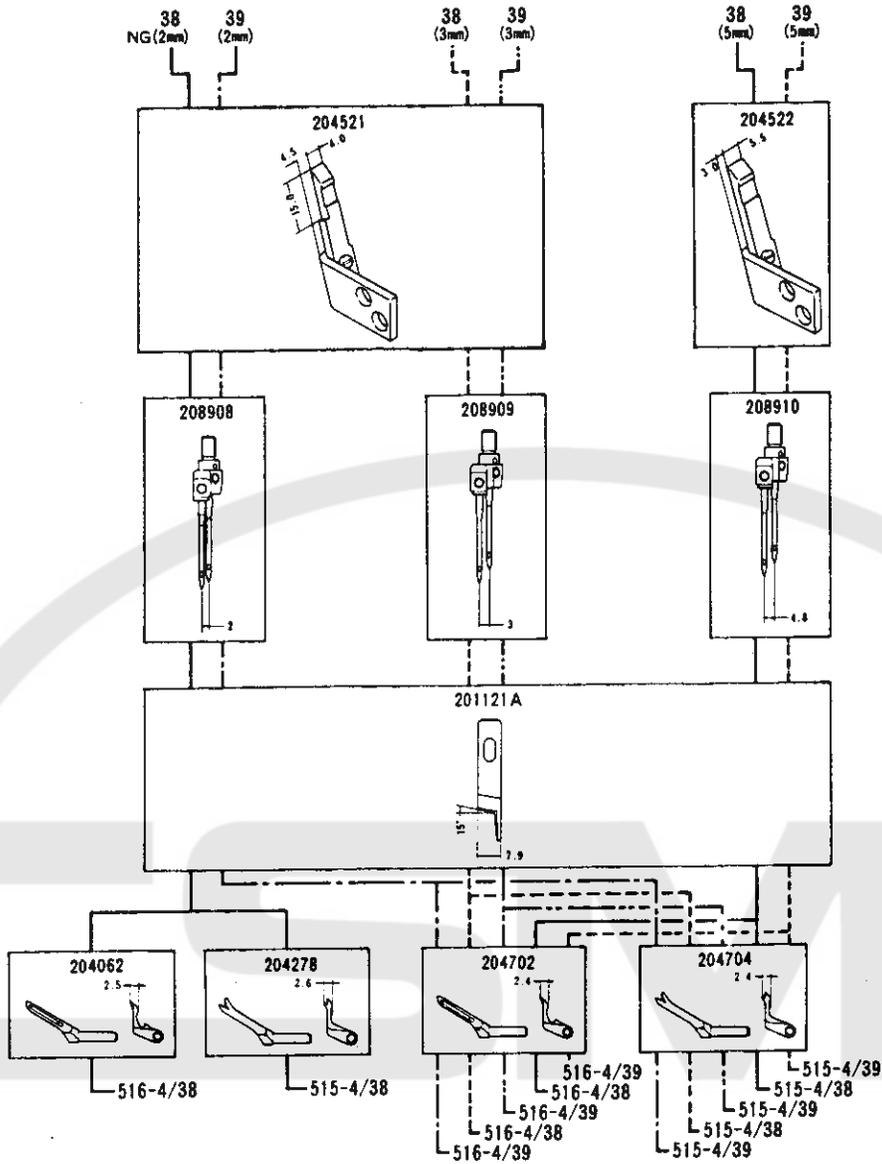

					MEMO	
516(515) -4/38	2	3, 4, 5, 6	1~3		For intermittent shirring on light to medium weight materials such as negligee, curtains etc.	
	3	3, 4, 5, 6	1~3			
	5	3, 4, 5, 6	1~3			
516(515) -4/39	2	3, 4, 5, 6	1~3		For intermittent shirring on heavy weight materials such as curtains, bed spreaders, gowns etc.	
	3	3, 4, 5, 6	1~3			
	5	3, 4, 5, 6	1~3			

**GAUGE PARTS
CONSTRUCTION CHART**

Feed pattern : 2W(2-row wide)

516-4/551

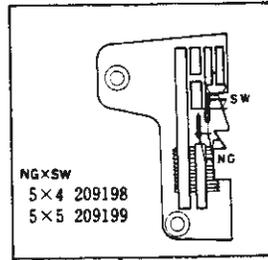
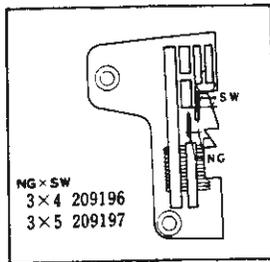

NG = Needle Gauge
SW = Seam Width

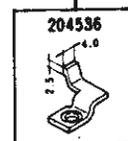
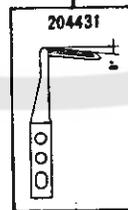
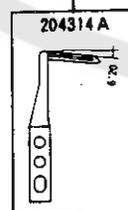
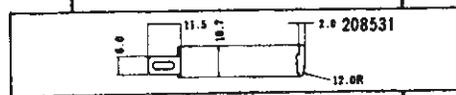
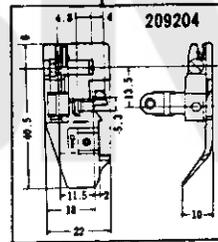
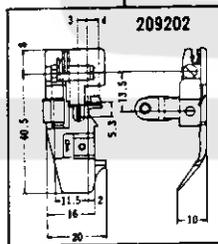
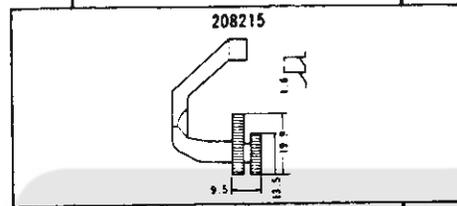
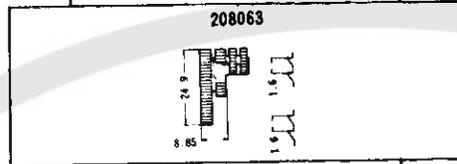

551
NG(3mm)

551
(5mm)

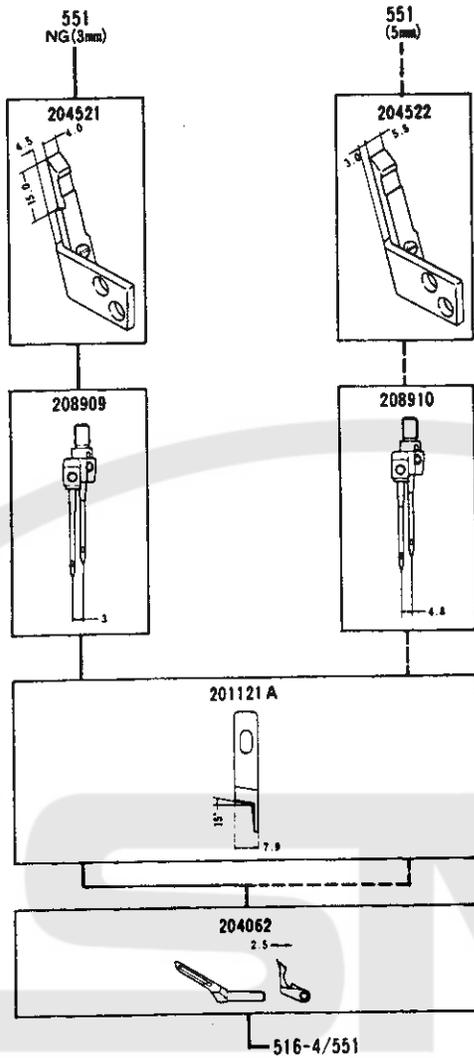

				MEMO	
516-4/551	3 5	4,5	0.7-2		Fitted with a binding attachment to insert a tape inside seam. Ensures high quality results.

**GAUGE PARTS
CONSTRUCTION CHART**

Feed pattern : 3W (3-row wide)

516-4/38P1 (P2)

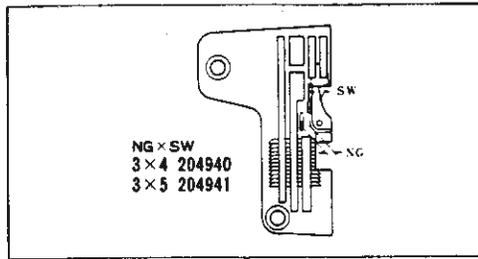

NG = Needle Gauge
SW = Seam Width

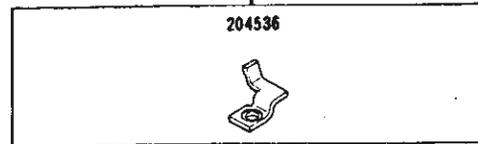
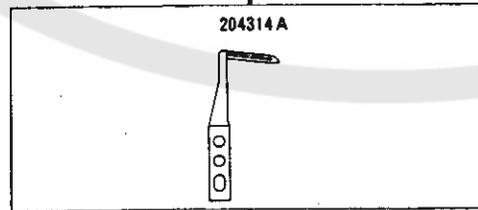
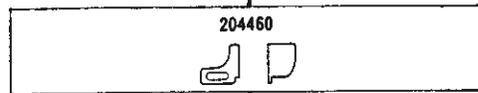
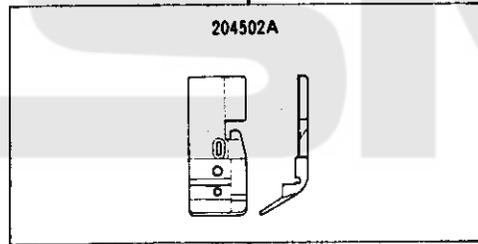
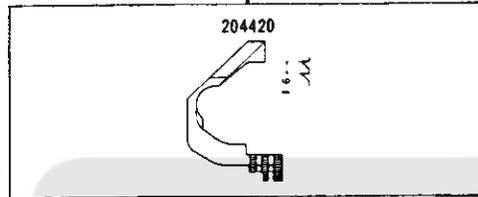
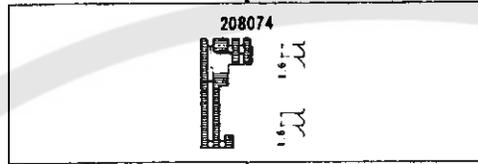

38P1 (P2)

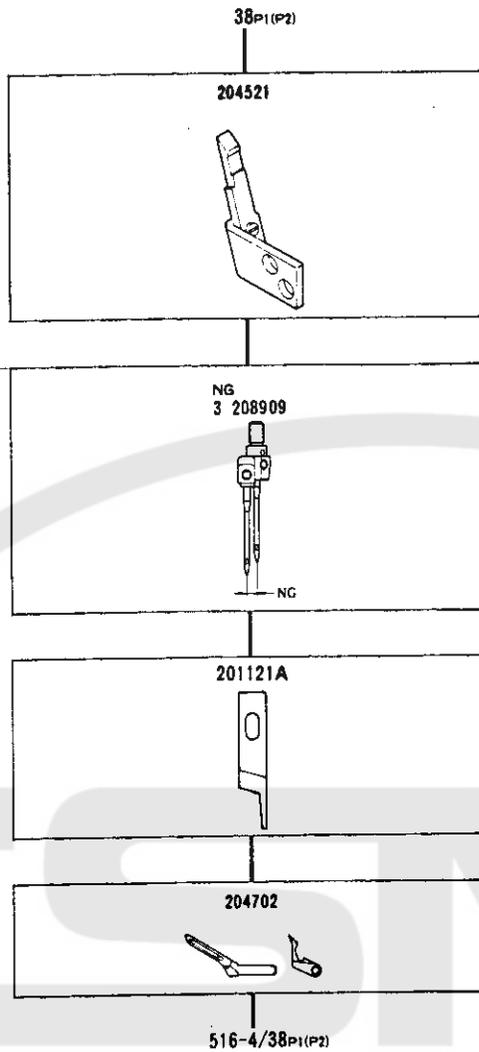

				MEMO	
516-4/38P1	3	4,5	1~3		For shirring/piping on light to medium weight fabrics such as knit shirts, sweat pants, pajamas, womens' and kids' clothes.
516-4/38P2					

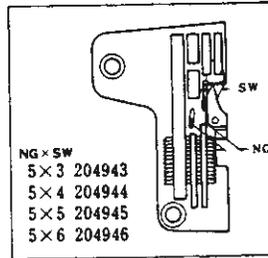
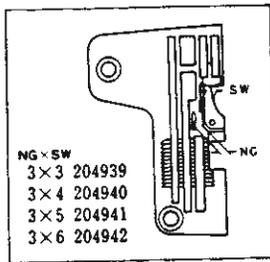

NG = Needle Gauge
SW = Seam Width

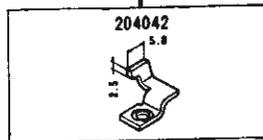
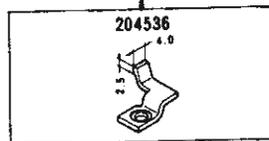
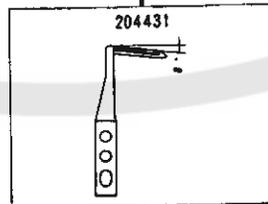
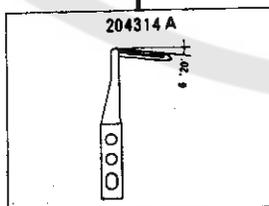
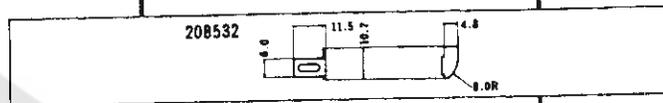
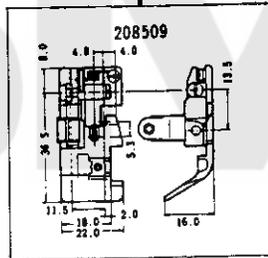
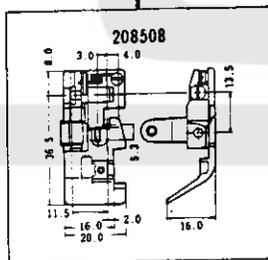
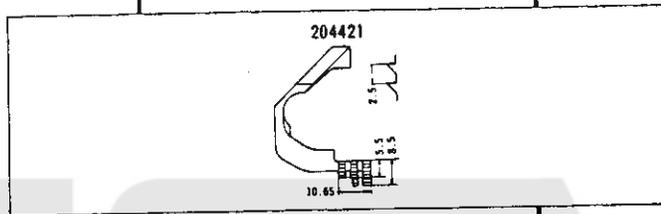
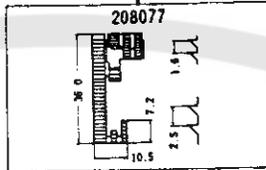
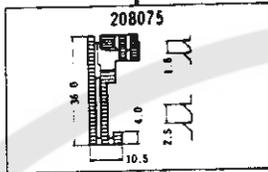

39P1(P2)
NG (3mm)

39P1(P2)
(5mm)

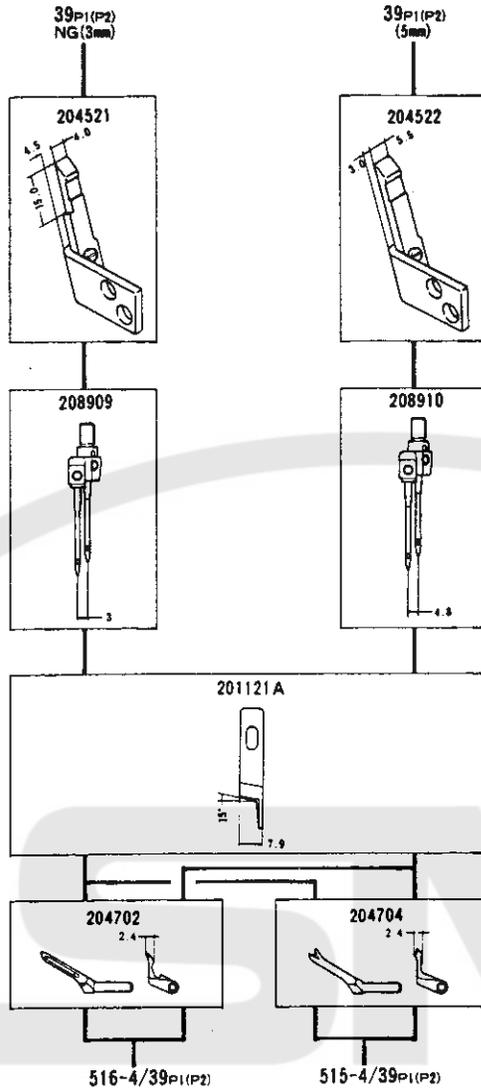

**AUGE PARTS
CONSTRUCTION CHART**

Need pattern: 2N (2-row narrow)
2W (2-row wide)

355, 359, 555, 559

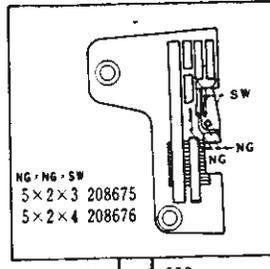
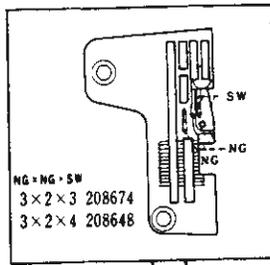

NG = Needle Gauge
SW = Seam Width

355 359

555 559

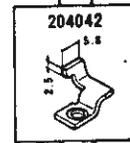
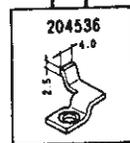
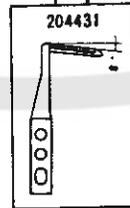
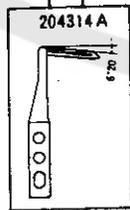
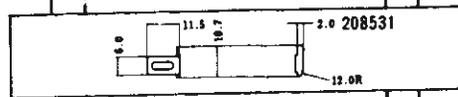
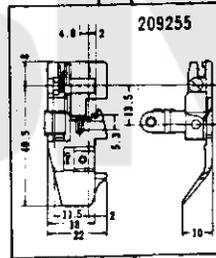
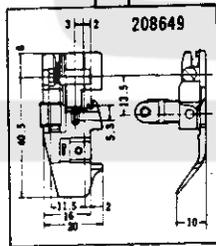
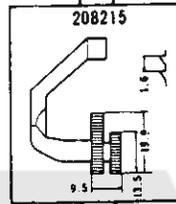
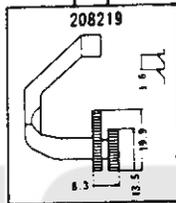
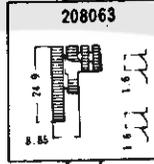
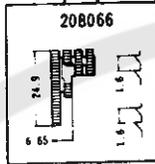

355 359

555 559

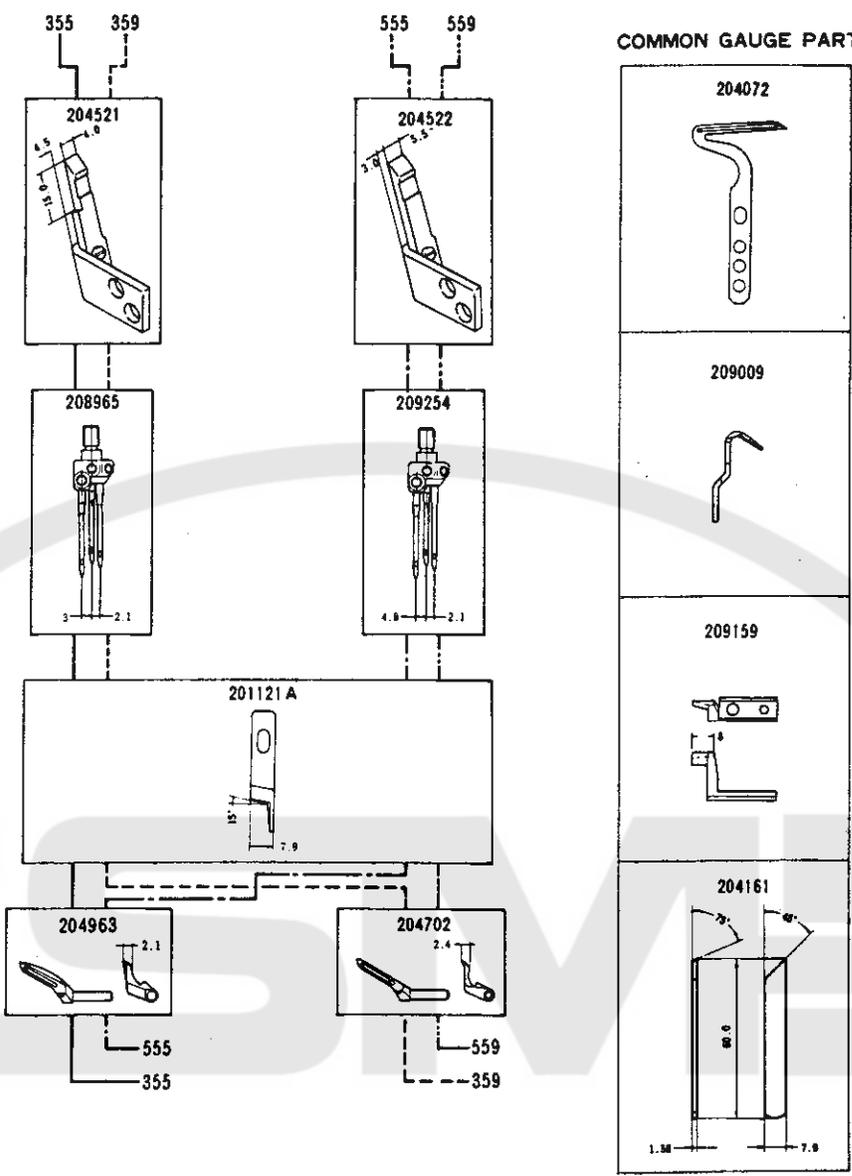

				MEMO	
355	3×2	3,4	0.6~2	<p>Versatile high speed machines. Five different stitch types make them especially suitable for short run, high fashion locations. Two further stitch types (503, 515) can be obtained merely by changing the upper looper.</p>	
359	3×2	3,4	0.6~2		
555	5×2	3,4	0.6~2		
559	5×2	3,4	0.6~2		

**JGE PARTS
INSTRUCTION CHART**

pattern : 2-row
wing land : no

505-4/25
504-4/19

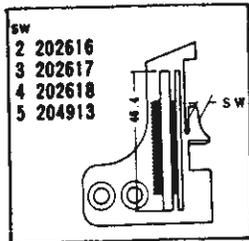
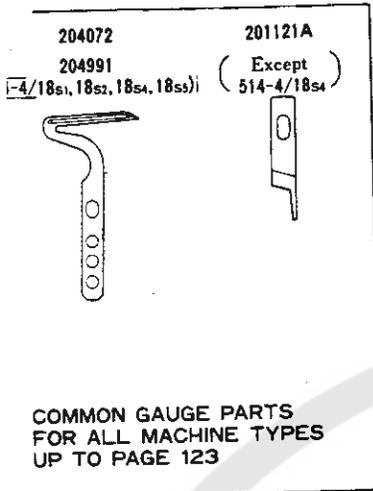

① 19
② 25

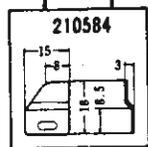
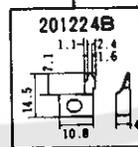
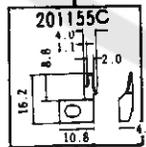
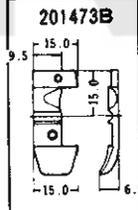
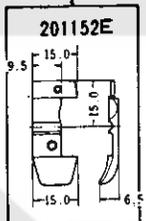
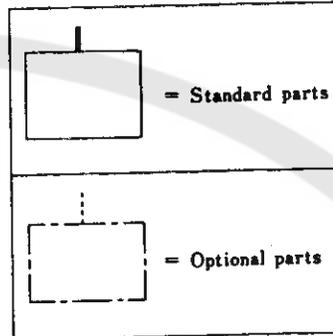
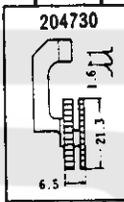
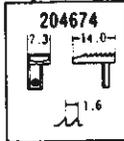
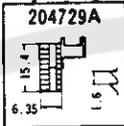

25 19

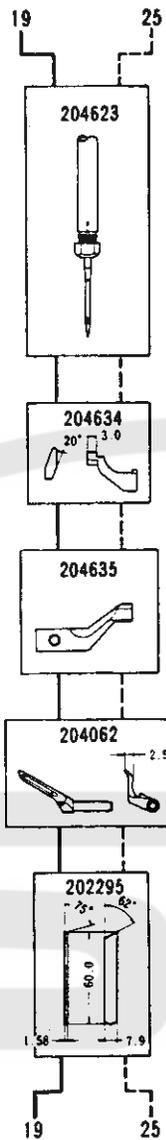

				MEMO	
505-4/25	2, 3, 4, 5	505	0.6-2		Three thread blindstitch hemming on U-necked undershirts athletic shirts, mens and womens briefs etc.
504-4/19	2, 3, 4, 5	504	0.6-2		For sleeve, side and shoulder closing operations on light to medium weight materials such as underwear and ladies' and children's outerwear.

**GAUGE PARTS
CONSTRUCTION CHART**

Feed pattern : 2-row
Chaining land : yes

503-4/44
504-4/45

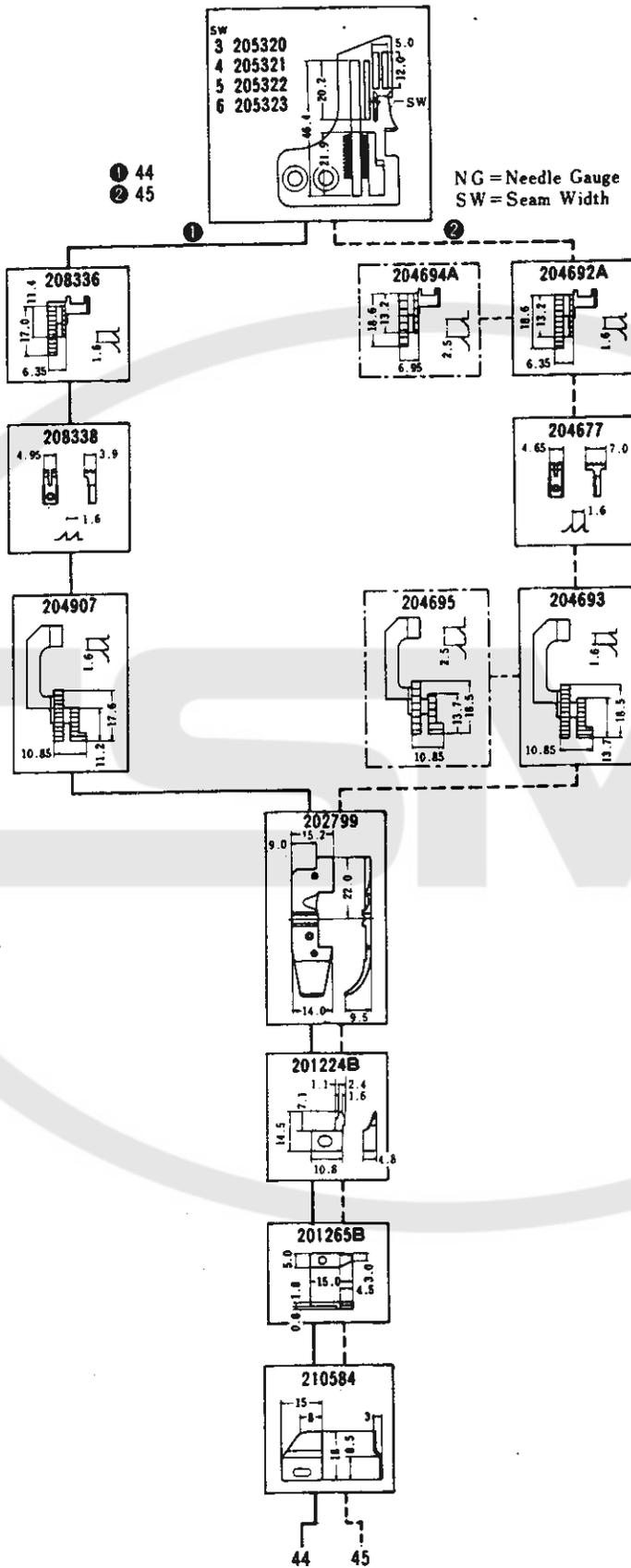

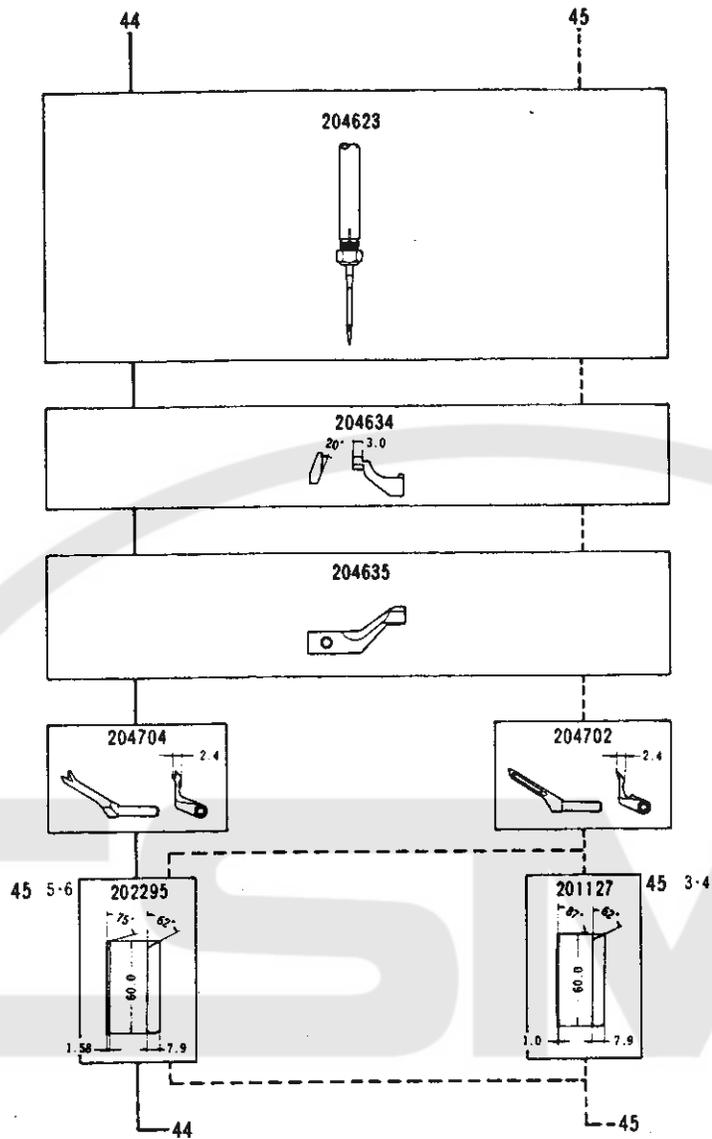

				MEMO	
503-4/44	3, 4, 5, 6	503	0.6-1.3		General serging operations on slacks, jackets working wear etc.
504-4/45	3, 4, 5, 6	504	0.6-2		For sleeve, side and shoulder closing operations on light to medium weight materials such as underwear and ladies' and children's outerwear.

**GAUGE PARTS
CONSTRUCTION CHART**

504-4/7, 66, 65, 69, 21

Feed pattern : 3-row
Chaining land : no

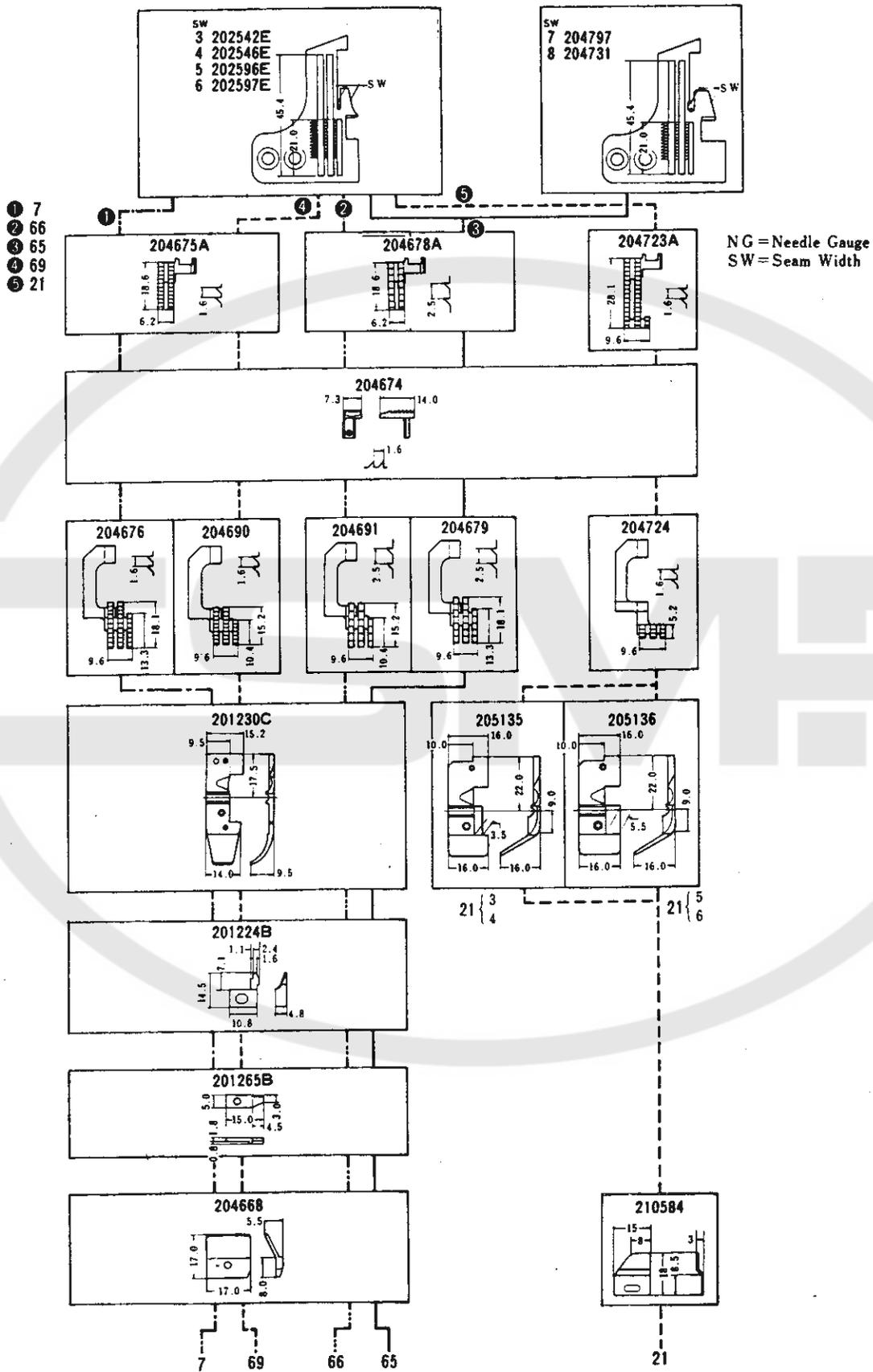

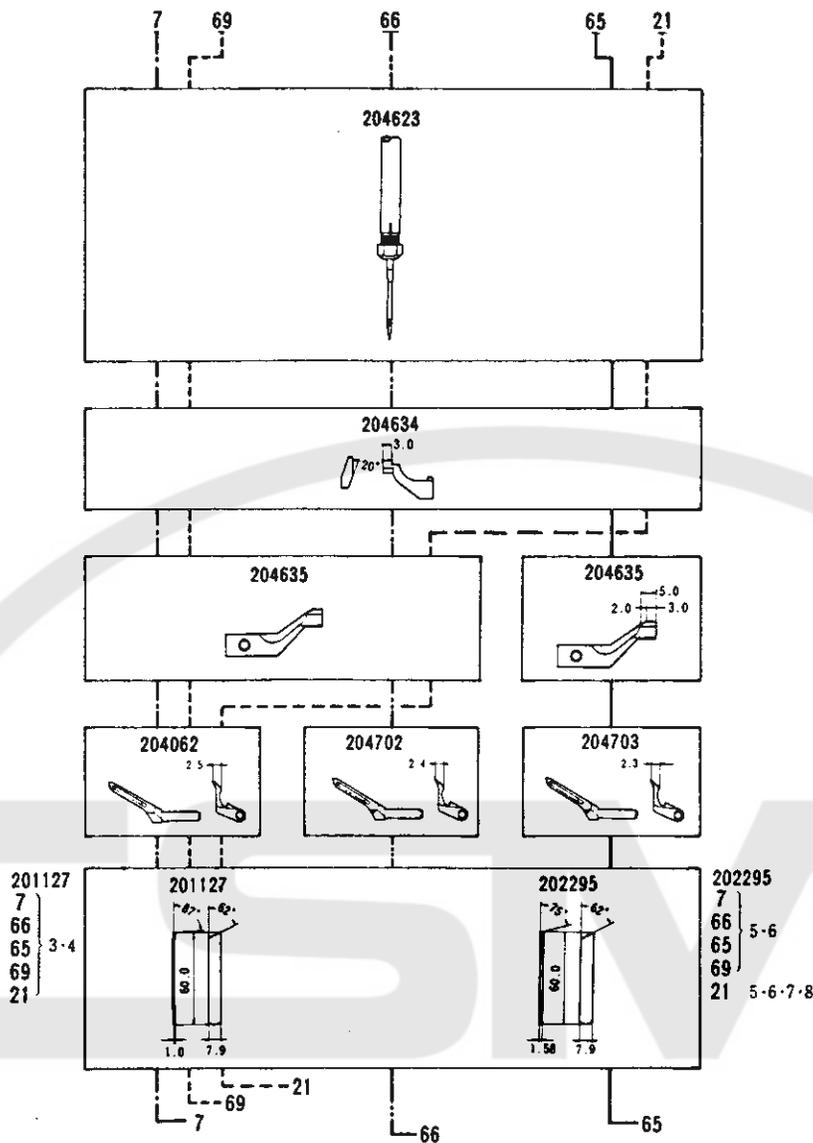

				MEMO	
504-4/7	3, 4, 5, 6	504	0.6-2		For sleeve, side and shoulder closing operations on light to medium weight materials such as underwear and ladies' and children's outerwear.
504-4/66	3, 4, 5, 6	504	1-3		Specially designed for seaming bulky knit materials such as sweaters, cardigans etc.
504-4/65	3, 4, 5, 6 7, 8	504	0.6-2		Seaming or serging on extra heavy weight materials such as jeans.
504-4/69	3, 4, 5, 6	504	1-3		For sleeve, side and shoulder closing operations on light to medium weight materials such as underwear and ladies' and children's outerwear.
504-4/21	3, 4, 5, 6	504	1-3		Single needle overedgers for intermittent shirring on light to medium weight materials such as negligee, curtains etc.

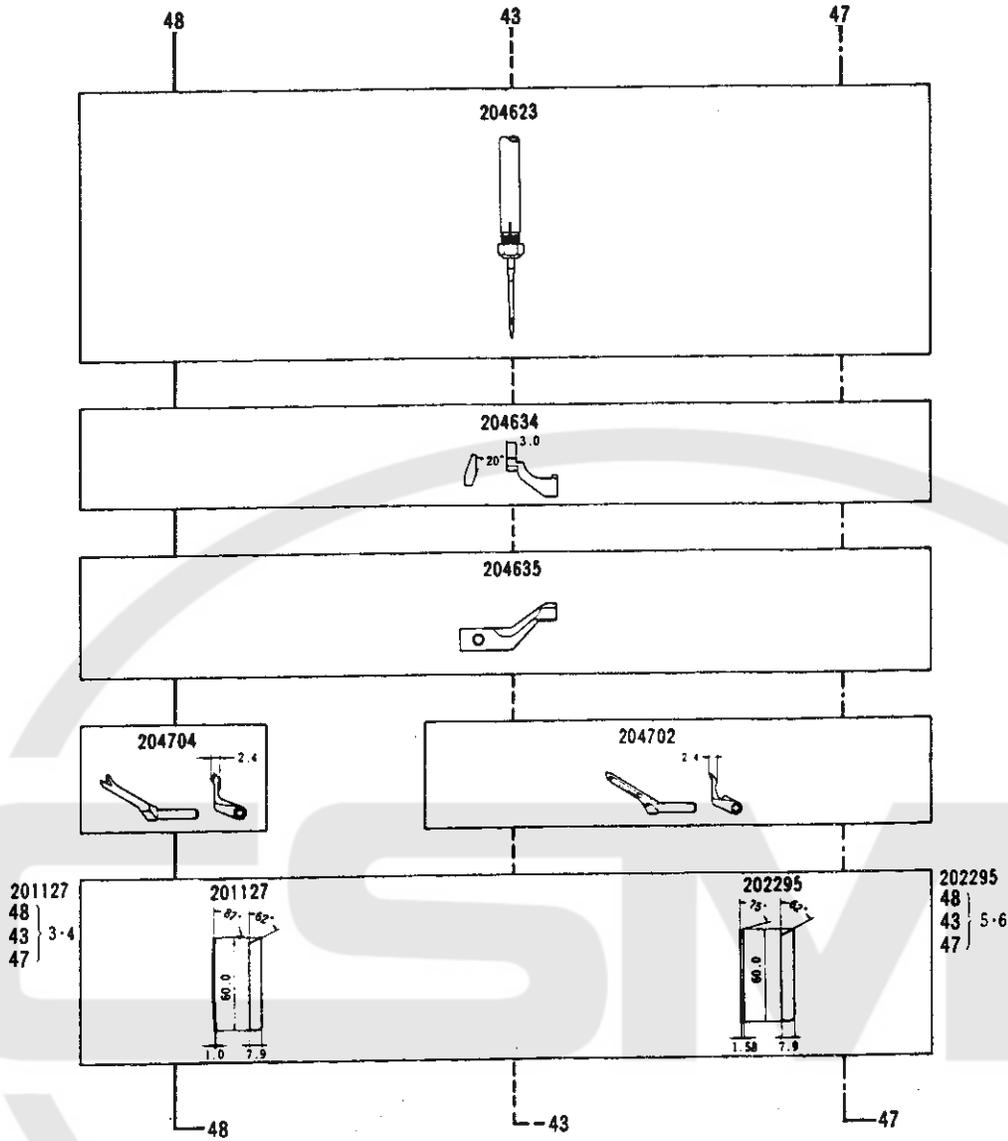

				MEMO	
503-4/48	3, 4, 5, 6	503	0.6~1.3		General serging operations on slacks, jackets working wear etc.
504-4/43	3, 4, 5, 6	504	0.6~2		For sleeve, side and shoulder closing operations on light to medium weight materials such as underwear and ladies' and children's outerwear.
504-4/47	3, 4, 5, 6	504	0.6~2		Seaming on medium heavy materials such as bed spreaders, chair covers etc.

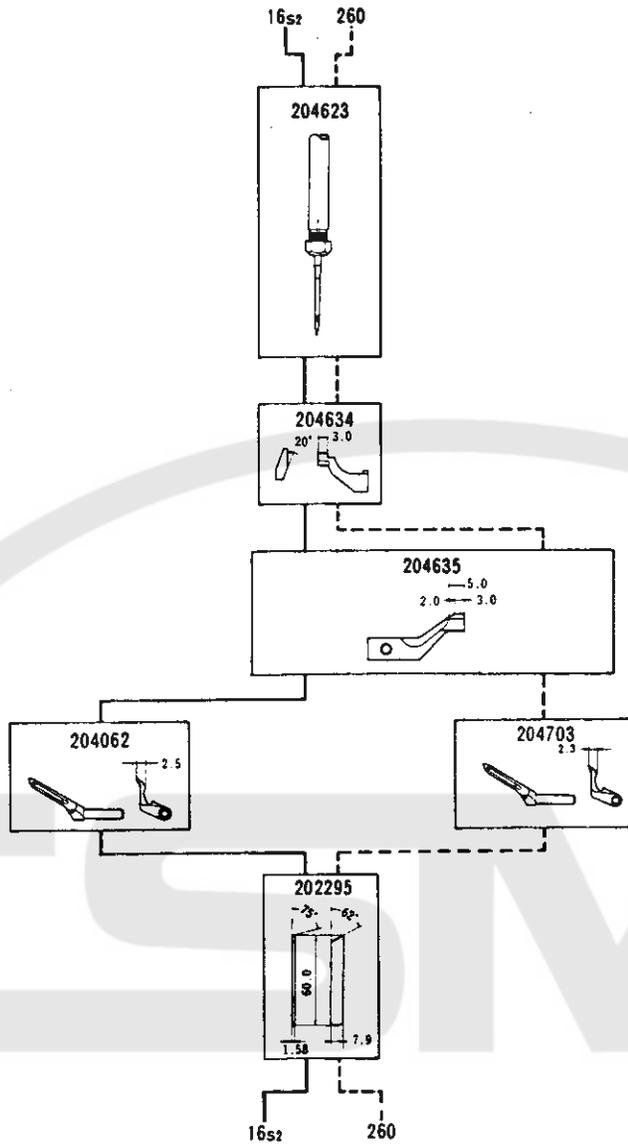

				MEMO	
504-4/16s2	1.5	504	0.6~2		Three thread overedger for turndown hemming on lightweight materials such as handkerchiefs, curtains etc.
504-4/260	5.6	504			Attaching zipper.

**GAUGE PARTS
CONSTRUCTION CHART**

Feed pattern : 2-row
Chaining land : no

514-4/20

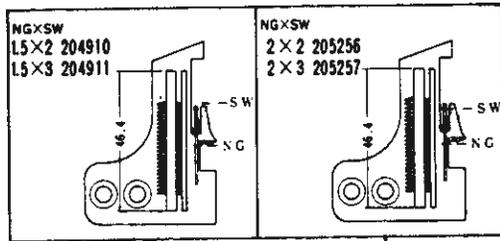

NG = Needle Gauge
SW = Seam Width

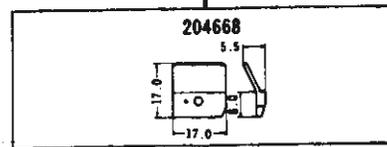
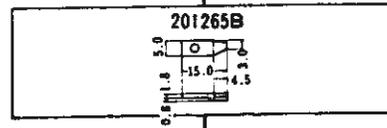
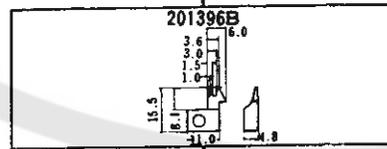
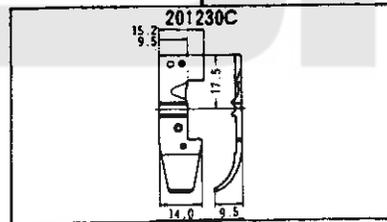
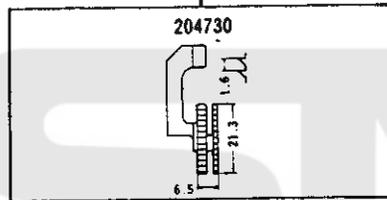
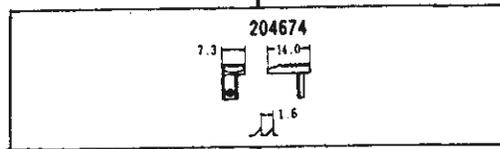
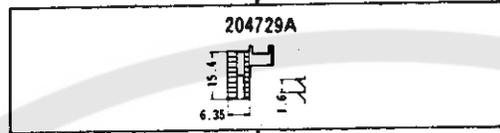

20

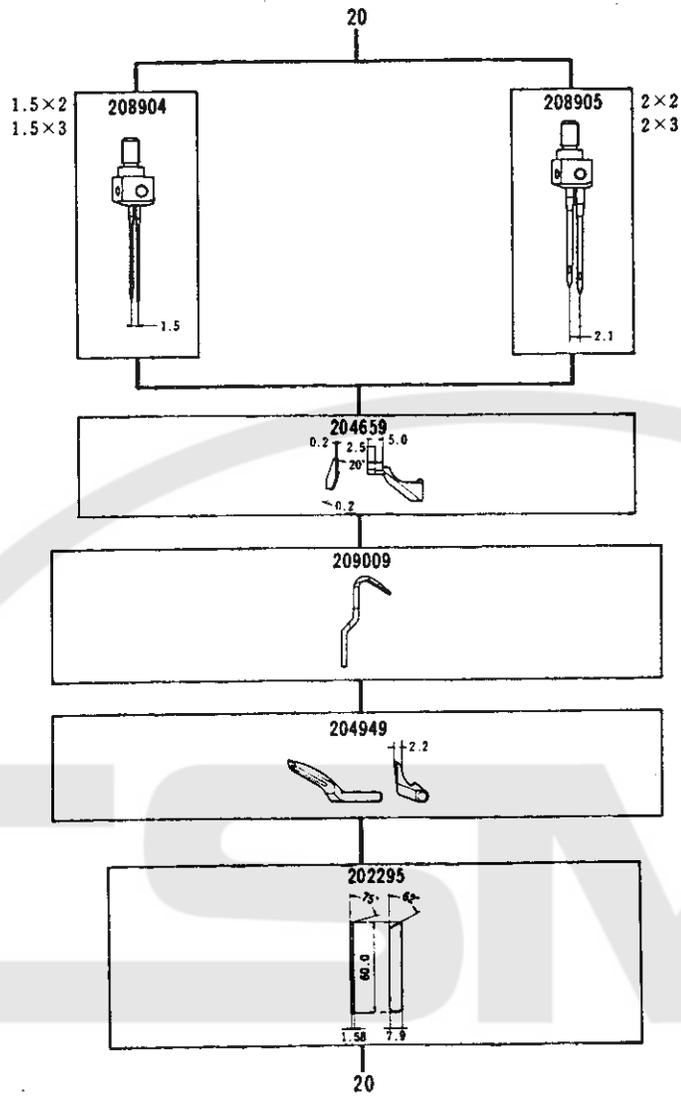

					MEMO	
514-4/20	1.5 2	2.3	514	0.6~2		Two needle machines for closing and attaching sleeves and side closing on light to medium weight materials.

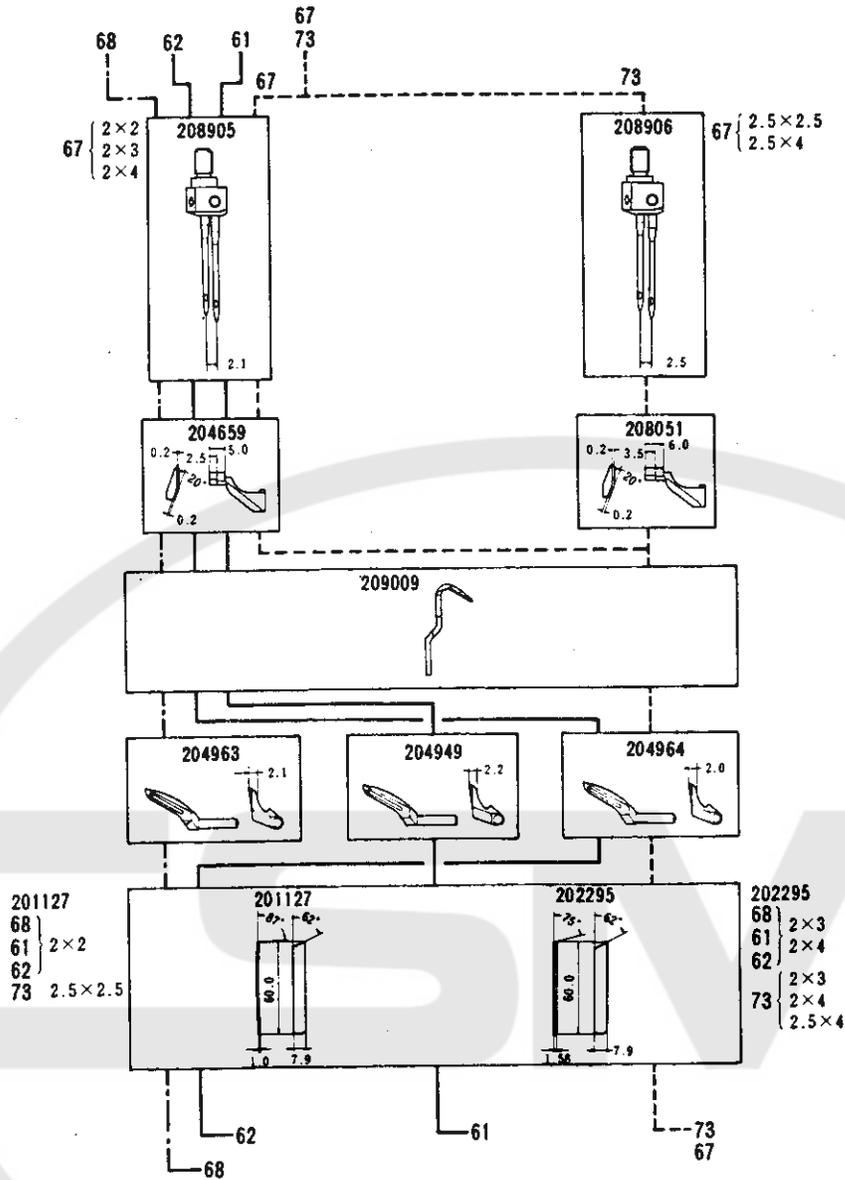

					MEMO	
514-4/68	2	2,3,4	514	1-3		Specially designed for seaming bulky knit materials such as sweaters, cardigans etc.
514-4/61	2	2,3,4	514	0.6-2		Two needle machines for closing and attaching sleeves and side closing on light to medium weight materials.
514-4/67	2	2,3,4	514	1-3		Specially designed for seaming bulky knit materials such as sweaters, cardigans etc.
514-4/73	2.5	2.5,4				Two needle overedgers for intermittent shirring on light to medium weight materials such as negligee, curtains etc.
514-4/62	2	2,3,4	514	1-3		

IE PARTS
STRUCTION CHART

attern : 3-row
ng land : yes

512-4/57, 64
514-4/64

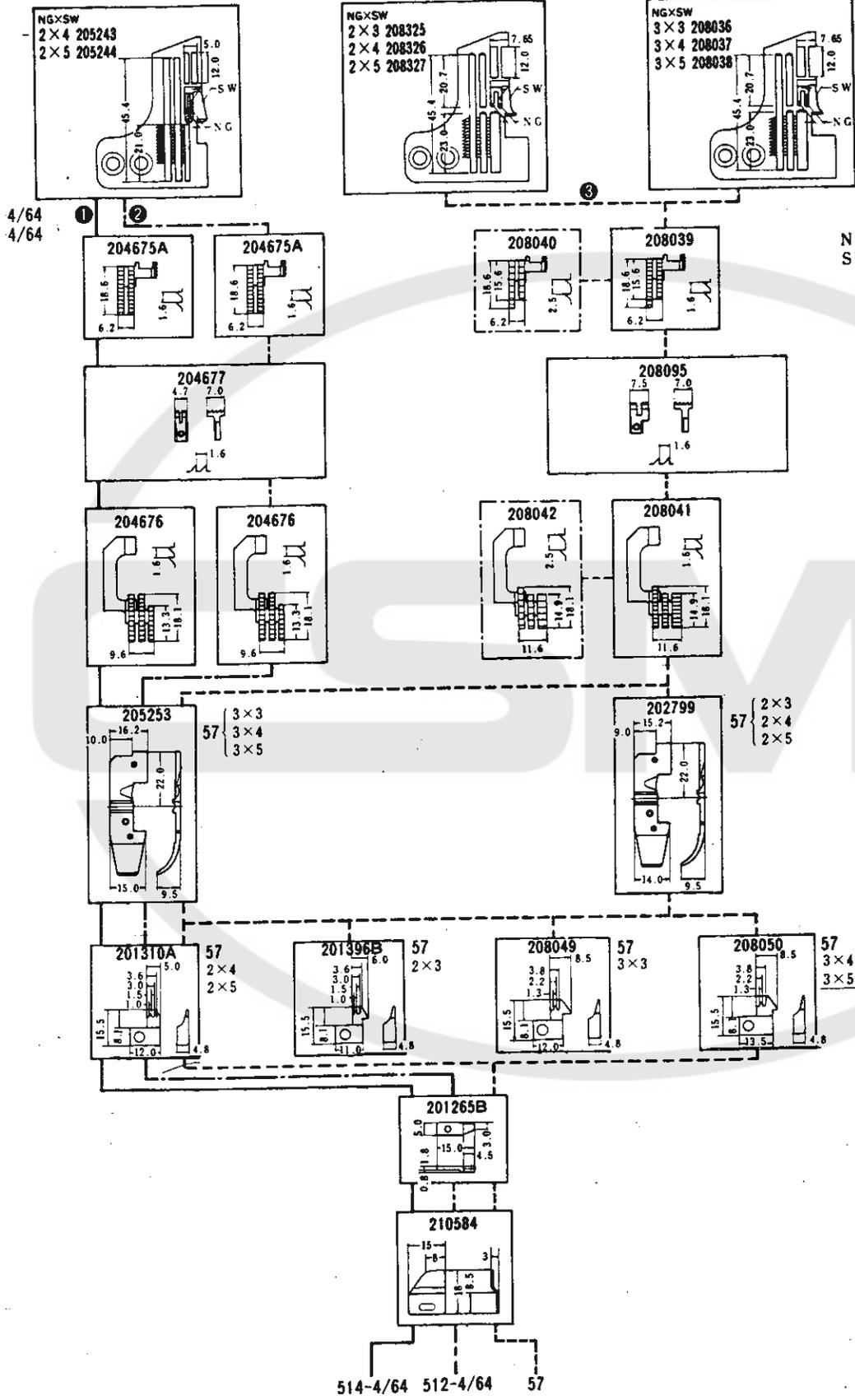

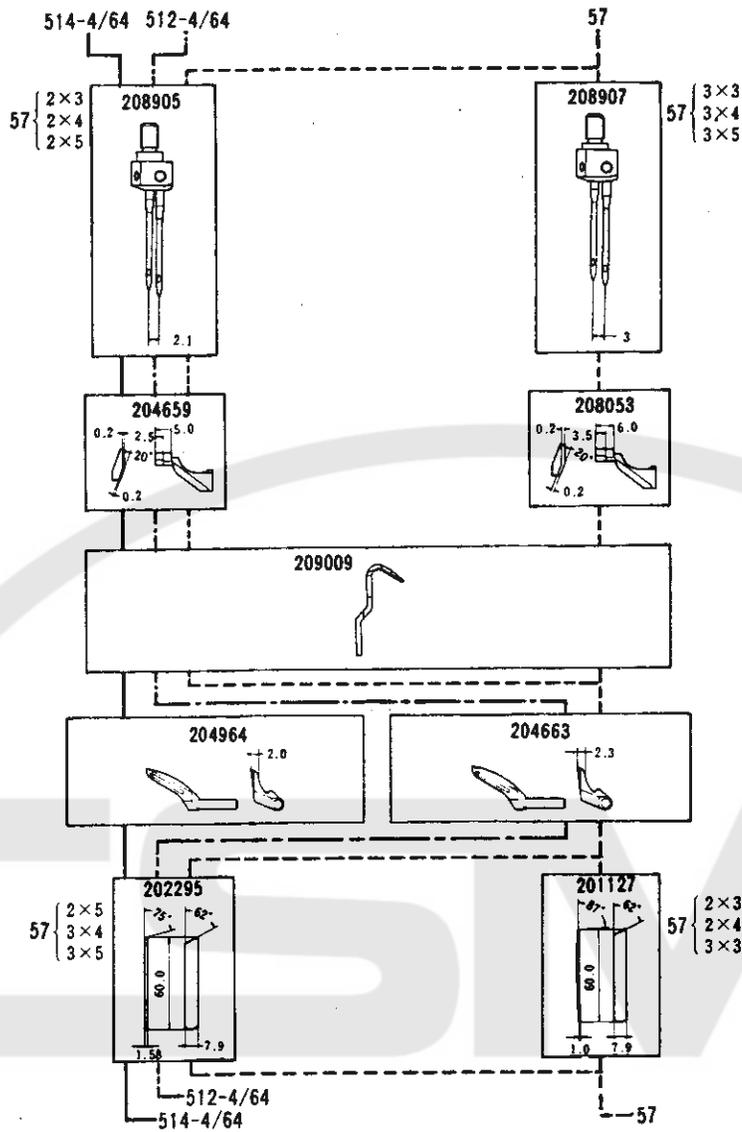

					MEMO	
512-4/64	2	4,5	512	0.6-2		Closing and attaching sleeves and side closing on dress shirts.
514-4/64	2	4,5	514	0.6-2		Two needle machines for closing and attaching sleeves and side closing on light to medium weight materials.
512-4/57	2 3	3,4,5	512	0.6-2		Closing and attaching sleeves and side closing on dress shirts.

UUGE PARTS
INSTRUCTION CHART

512-4/53, 61, 62, 73

ed pattern : 3-row
aining land : no

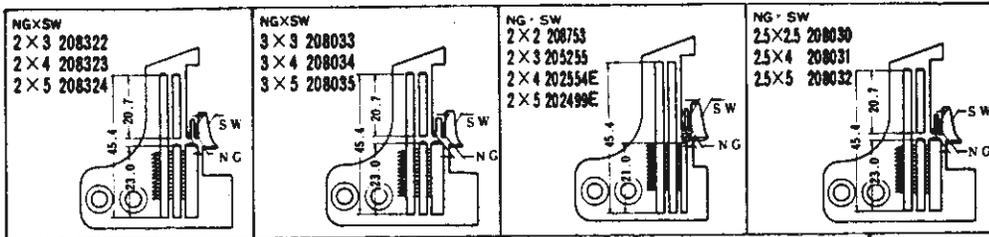

- ① 53
- ② 61
- ③ 62
- ④ 73

NG = Needle Gauge
SW = Seam Width

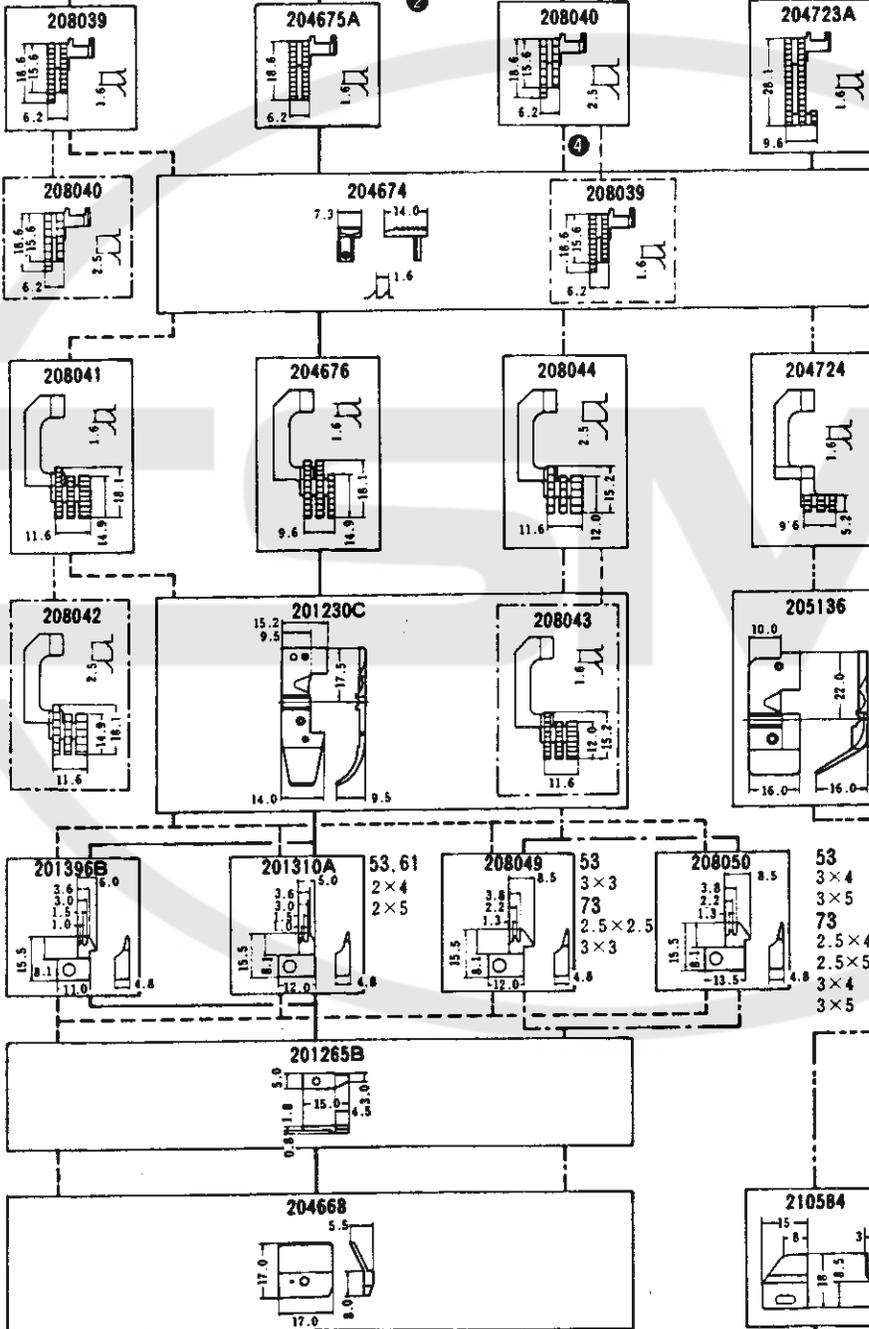

53

61

73

62

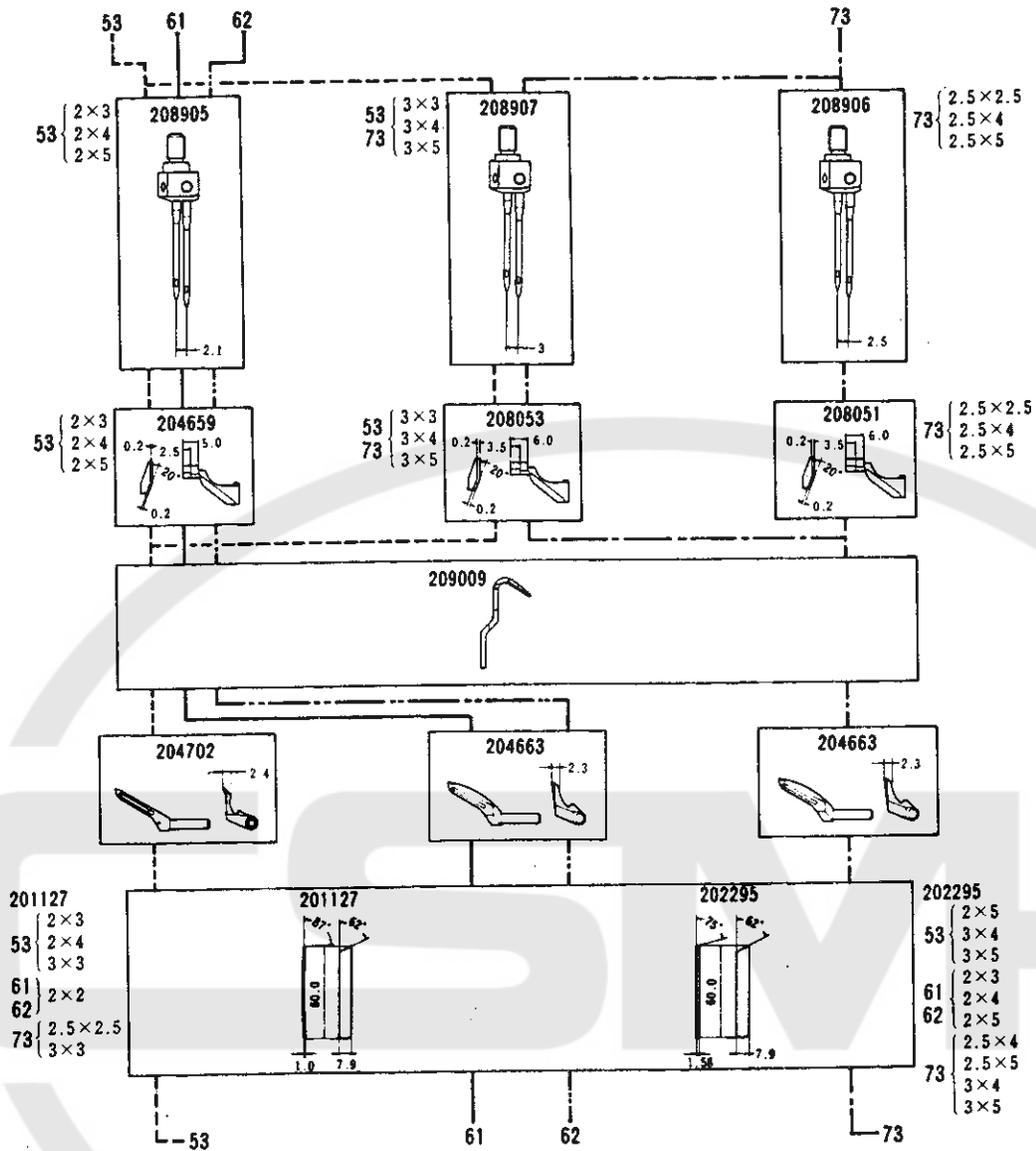

					MEMO	
512-4/53	2 3	3, 4, 5	512	0.6~2		Closing and attaching sleeves and side closing on dress shirts.
512-4/61	2	2, 3, 4, 5	512	0.6~2		
512-4/73	2.5 3	2.5, 4, 5 3, 4, 5	512	0.6~2		Specially designed for seaming bulky knit and woven materials such as sweaters, work wear etc.
512-4/62	2	2, 3, 4, 5	512	1~3		Mock safety stitch overedgers for intermittent shirring on light to medium weight materials such as negligee, curtain etc.

**GAUGE PARTS
CONSTRUCTION CHART**

Feed pattern : 3-row
Chaining land : no

514-4/18, 18s1, 18s2

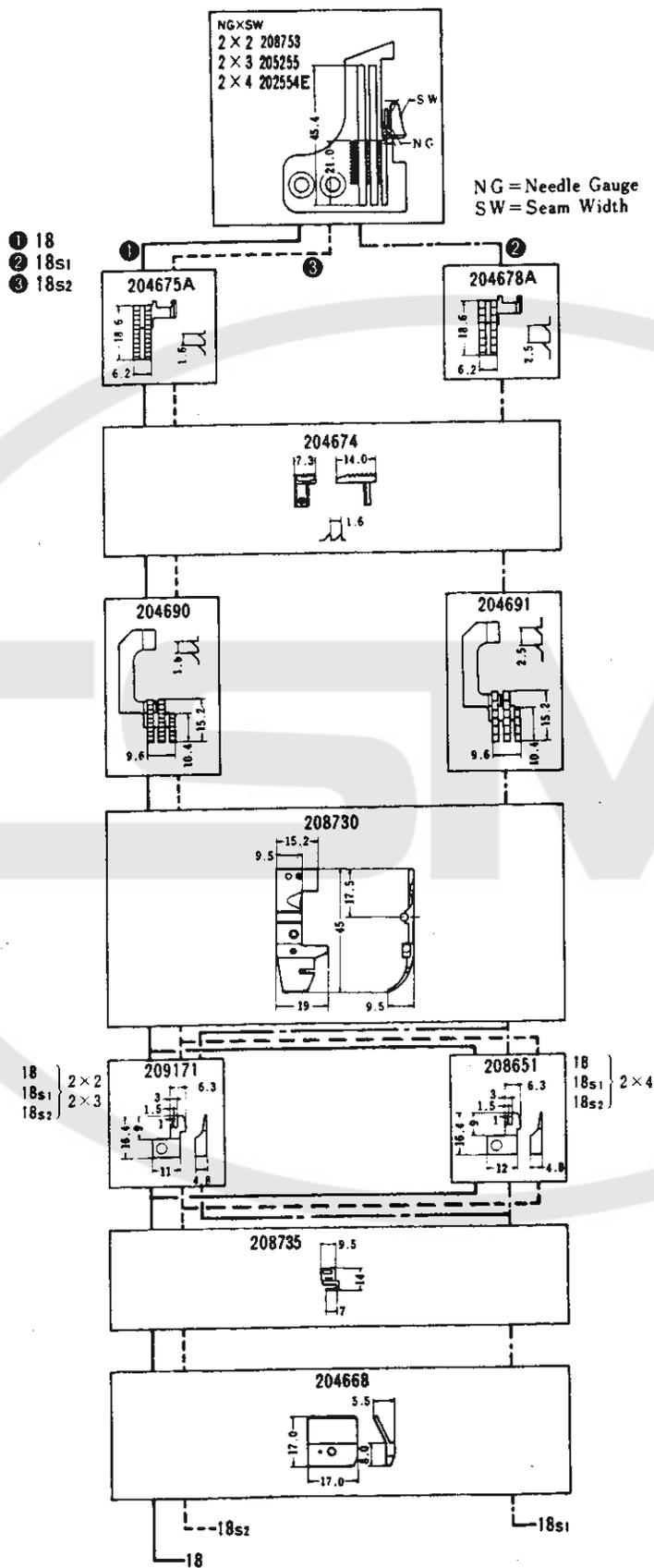

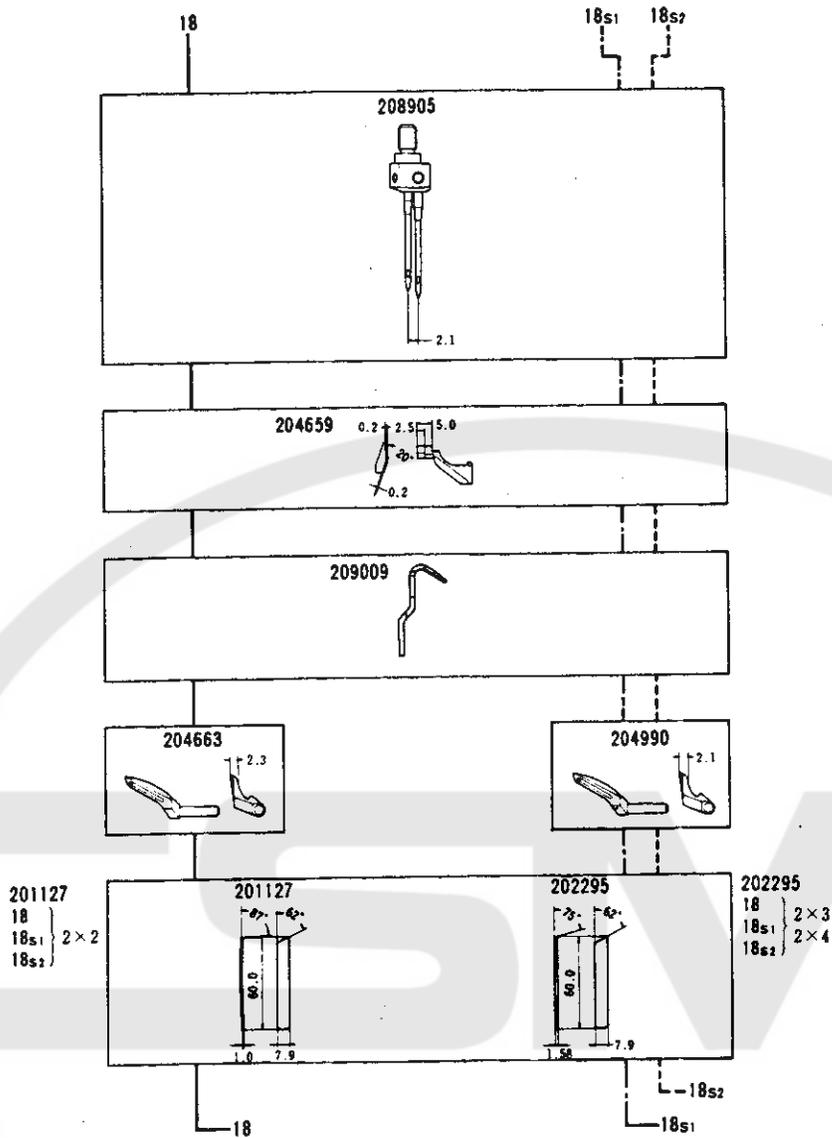

					MEMO	
514-4/18	2	2, 3, 4	514	1-3		Two needle machines for closing and attaching sleeves and side closing on light to medium weight materials.
514-4/18s1	2	2, 3, 4	514	1-3		Specially designed for seaming bulky knit materials such as sweaters, cardigans etc.
514-4/18s2	2	2, 3, 4	514	1-3		

**AUGE PARTS
CONSTRUCTION CHART**

514-4/18S4, 18S5

Feed pattern : 4-row

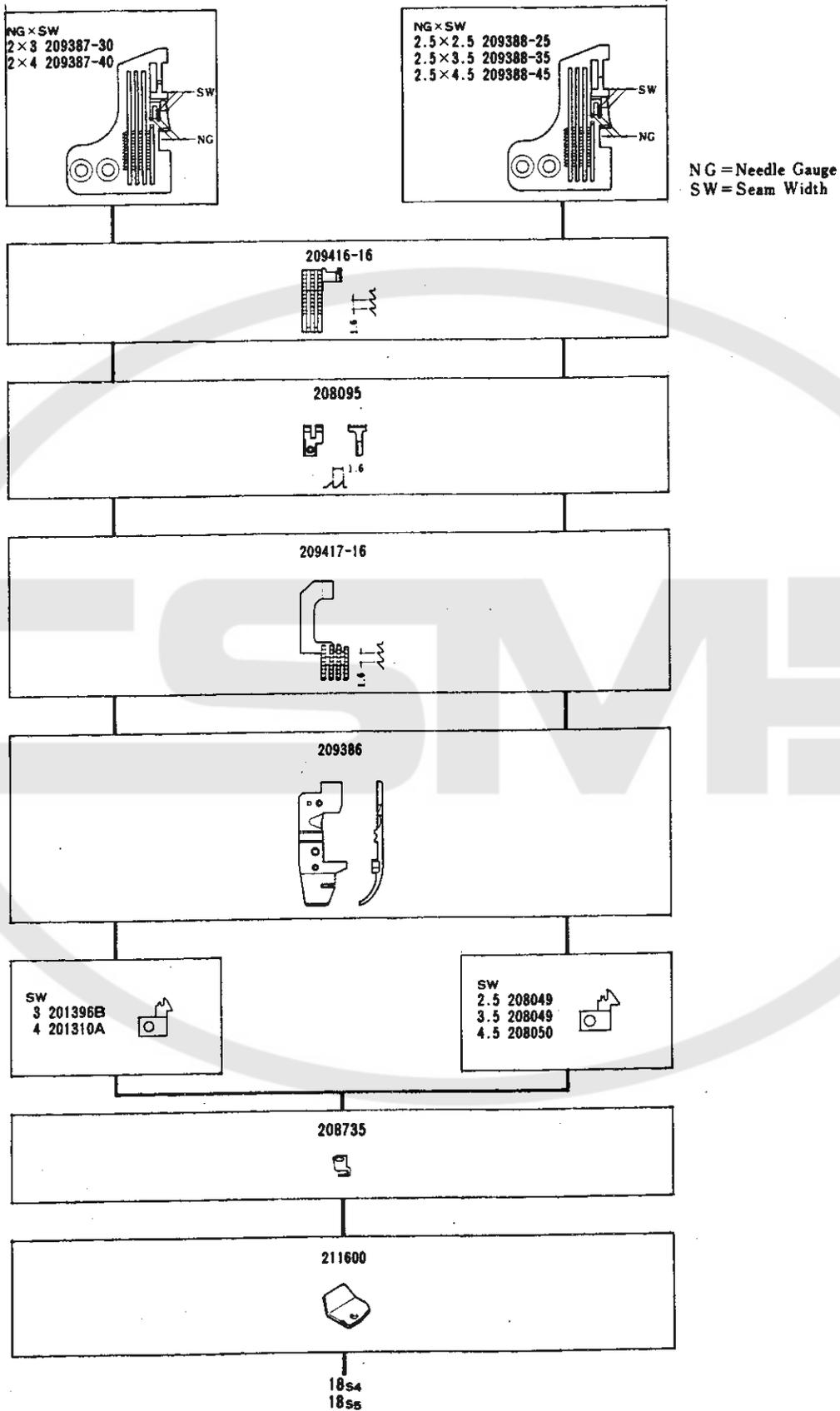

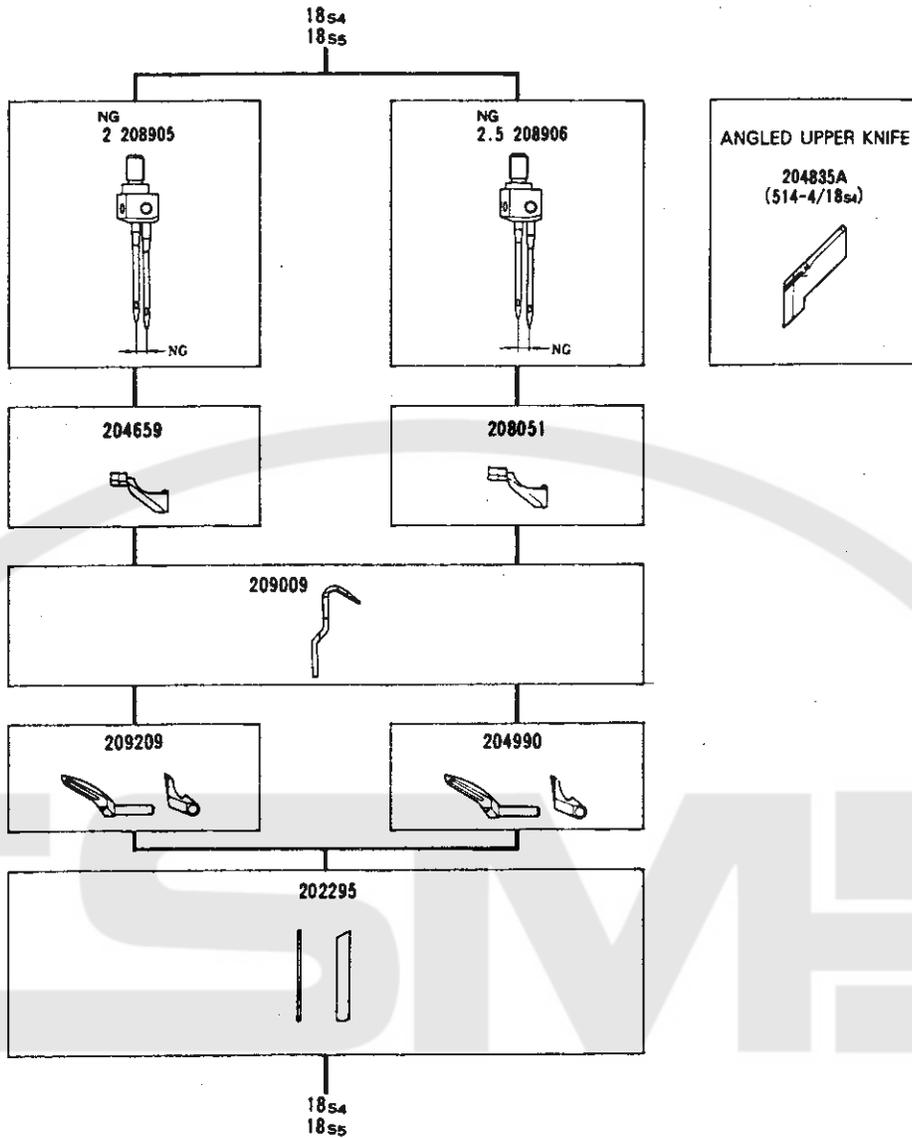

					MEMO	
514-4/18s4	2	3,4	514	1~3		For plain seaming on heavy weight fabrics (woolen fabrics) such as sweaters and cardigans.
	2.5	2,5,3,5,4,5				
514-4/18ss	2	3,4	514	1~3		For plain seaming on heavy weight fabrics (woolen fabrics) such as sweaters and cardigans.
	2.5	2,5,3,5,4,5				

**GAUGE PARTS
CONSTRUCTION CHART**

Feed pattern : 2-row
Chaining land : yes

512-4/72

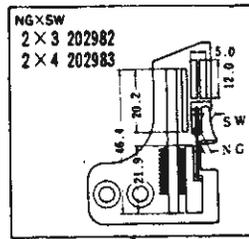

NG = Needle Gauge
SW = Seam Width

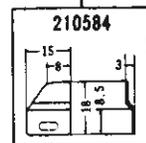
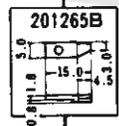
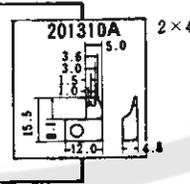
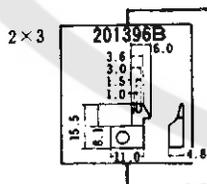
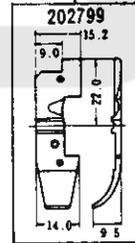
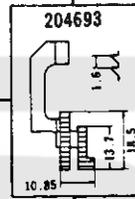
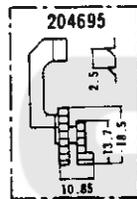
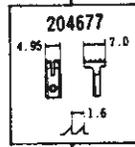
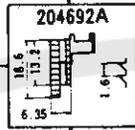
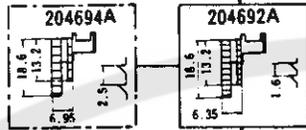

72

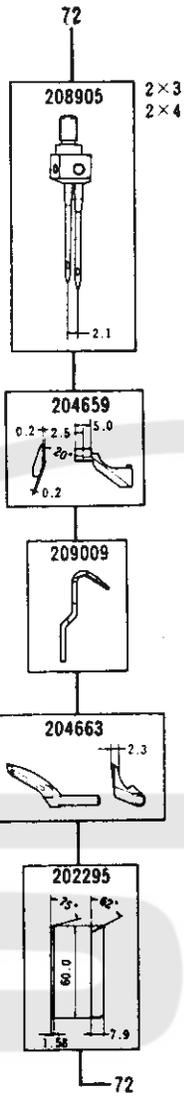

					MEMO	
512-4/72	2	3,4	512	0.6~2		Two needle machines for closing and attaching sleeves and side closing on light to medium weight materials.

**GAUGE PARTS
CONSTRUCTION CHART**

504-4/21P1 (P2), 62P1 (P2)

Feed pattern : 3-row

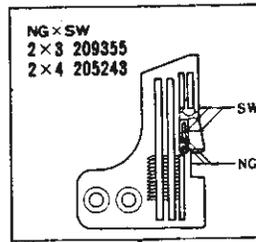
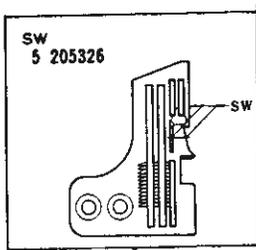

NG = Needle Gauge
SW = Seam Width

- ① 21P1 (P2)
- ② 62P1 (P2)

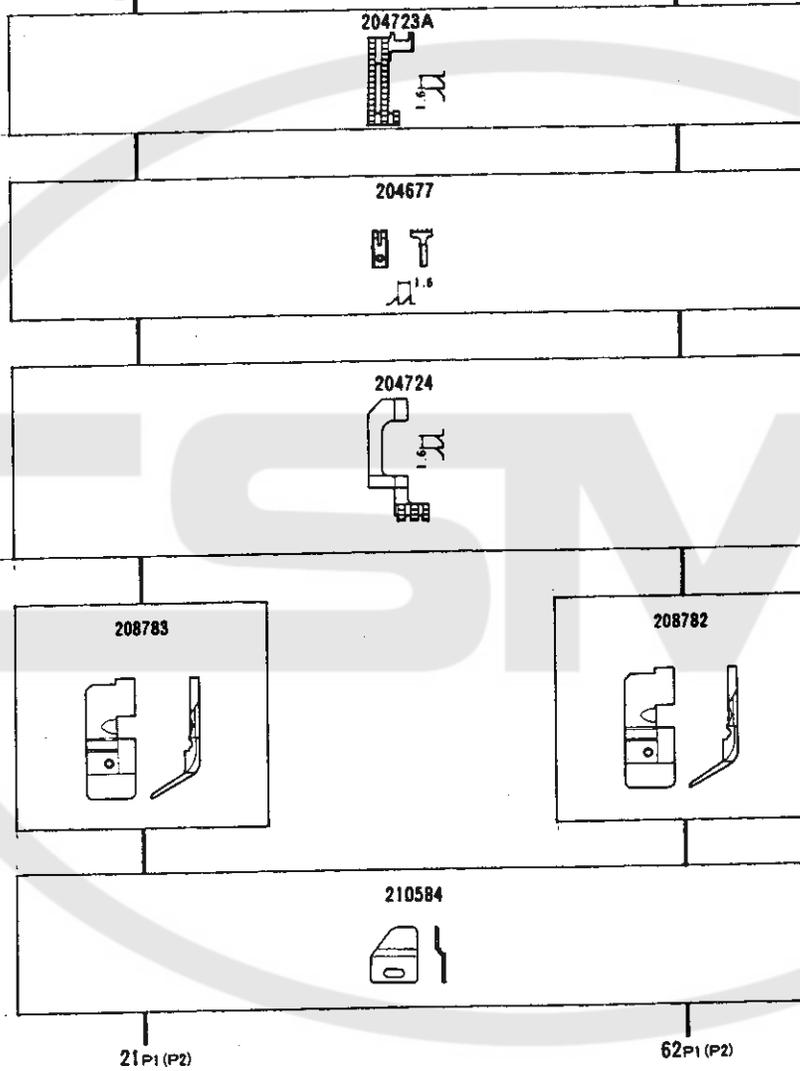

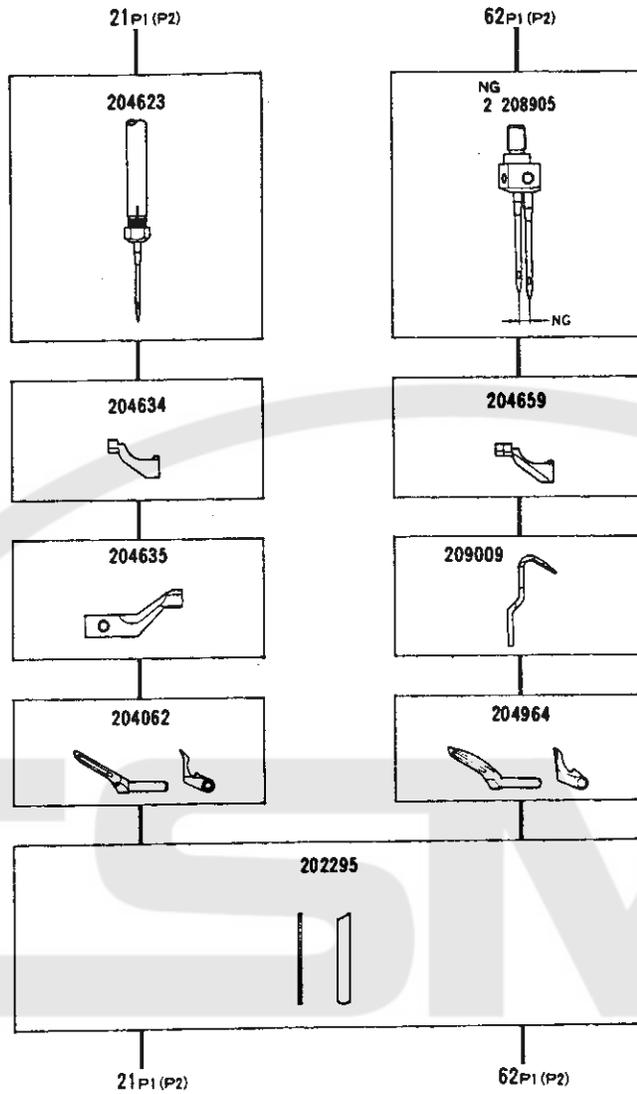

					MEMO	
504-4/21P1		5	504	1 ~ 3		For shirring/piping on medium weight fabrics such as knit shirts, sweat pants, pajamas and women's and kids' clothes.
504-4/21P2						
514-4/62P1	2	3,4	514	1 ~ 3		For shirring/piping on medium weight fabrics such as knit shirts, sweat pants, pajamas and women's and kids' clothes.
514-4/62P2						

**GAUGE PARTS
CONSTRUCTION CHART**

Feed pattern : 3-row

514-4/64P1(P2)
504-4/47P1(P2)

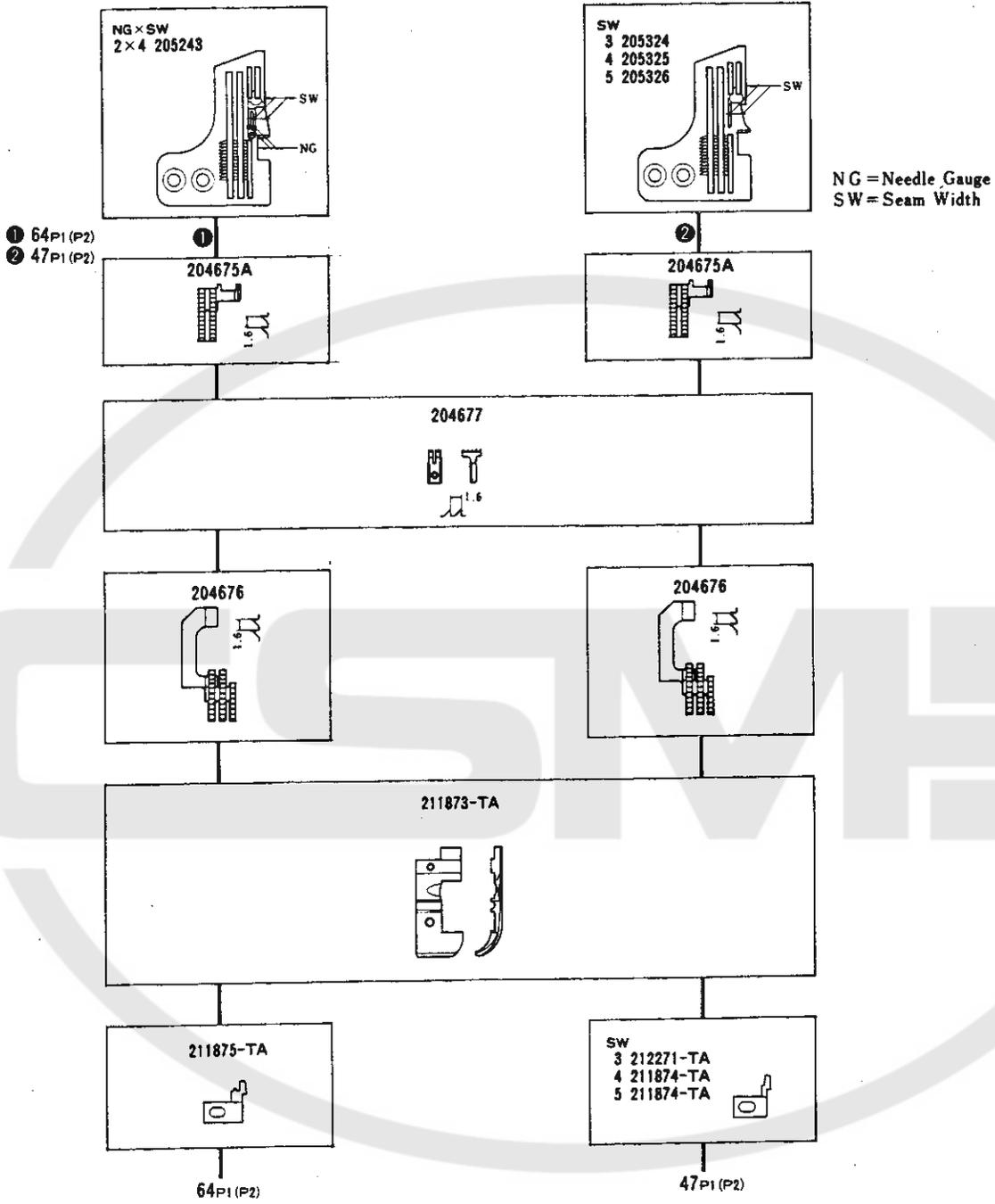

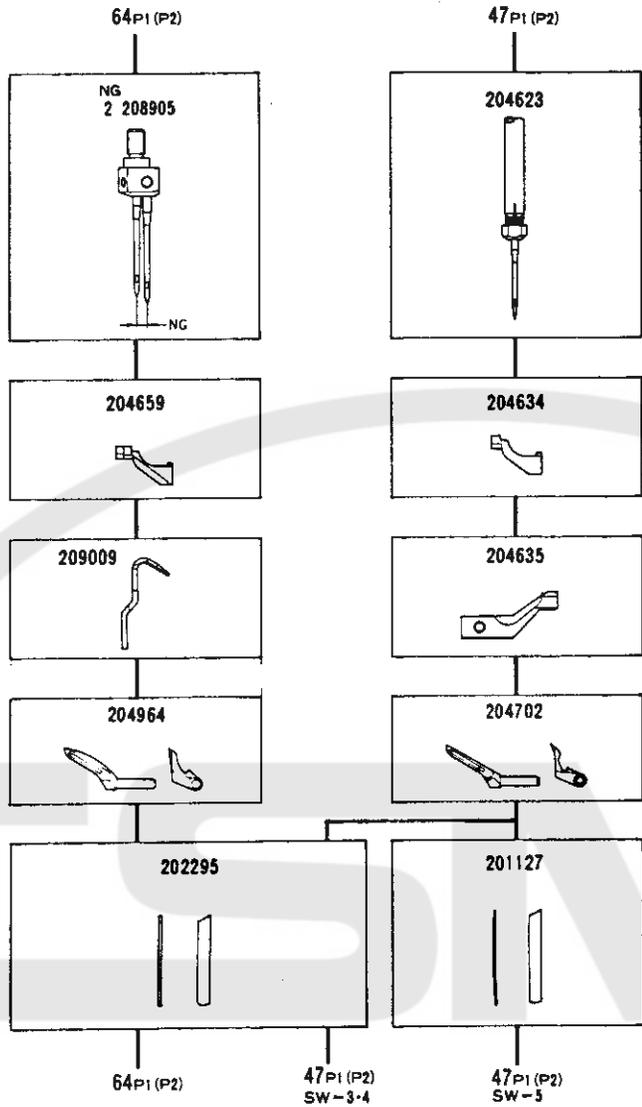

	 mm				MEMO	
514-4/64P1	2	4	514			For piping on medium weight fabrics such as knit shirts, sweat pants, pajamas and women's and kids' clothes.
514-4/64P2						
504-4/47P1		3,4,5	504			For piping on medium weight fabrics such as knit shirts, sweat pants, pajamas and women's and kids' clothes.
504-4/47P2						

Variable feed : Intermittent differential feed type.

**GAUGE PARTS
CONSTRUCTION CHART**

Feed pattern : 3-row

**504-4/350P1 (P2)
514-4/351P1 (P2)**

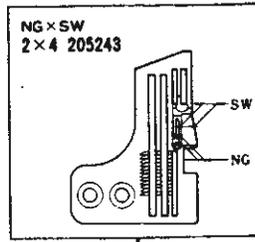
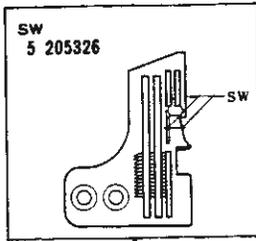

NG = Needle Gauge
SW = Seam Width

- ① 350P1 (P2)
- ② 351P1 (P2)

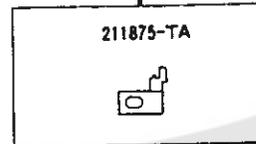
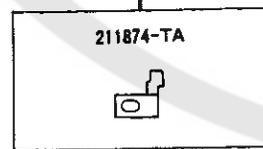
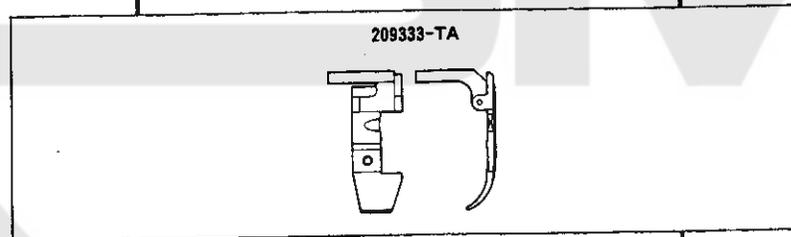
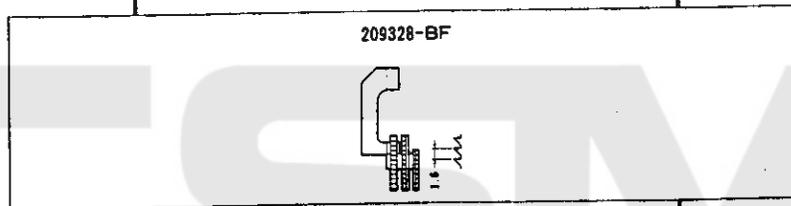
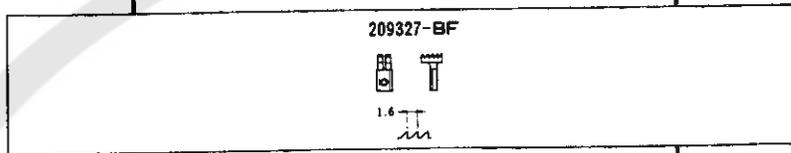
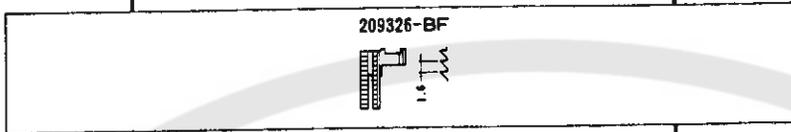

350P1 (P2)

351P1 (P2)

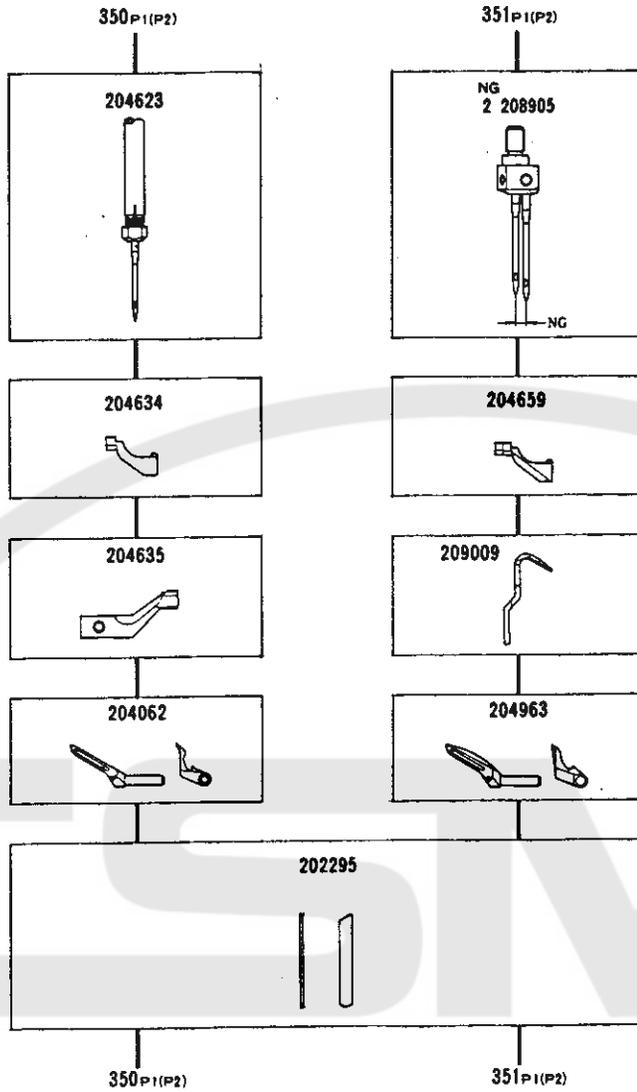

	 mm				MEMO	
504-4/350P1		5	504			For piping on medium weight fabrics such as knit shirts, sweat pants, pajamas and women's and kids' clothes.
504-4/350P2						
514-4/351P1	2	4	514			For piping on medium weight fabrics such as knit shirts, sweat pants, pajamas and women's and kids' clothes.
514-4/351P2						

• Variable feed : Intermittent differential feed type.

**GAUGE PARTS
CONSTRUCTION CHART**

**504-4/17
514-4/63
512-4/63**

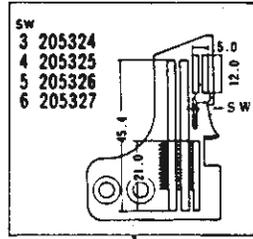
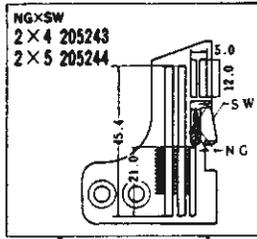

NG = Needle Gauge
SW = Seam Width

- ① 17
- ② 514-4/63
- ③ 512-4/63

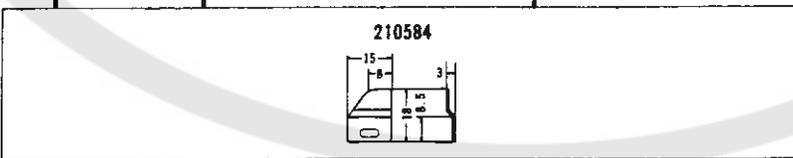
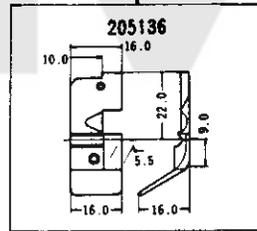
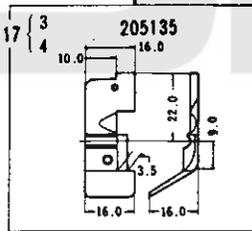
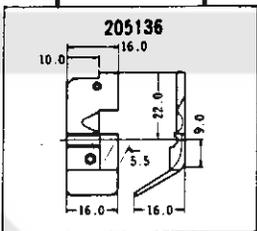
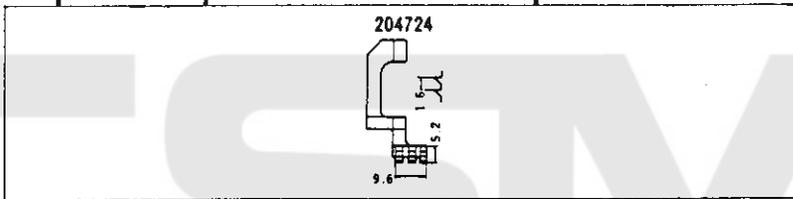
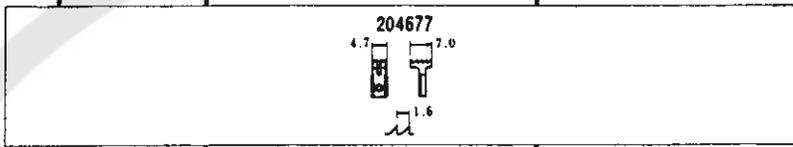
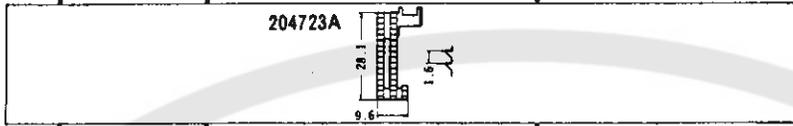

512-4/63

514-4/63

17

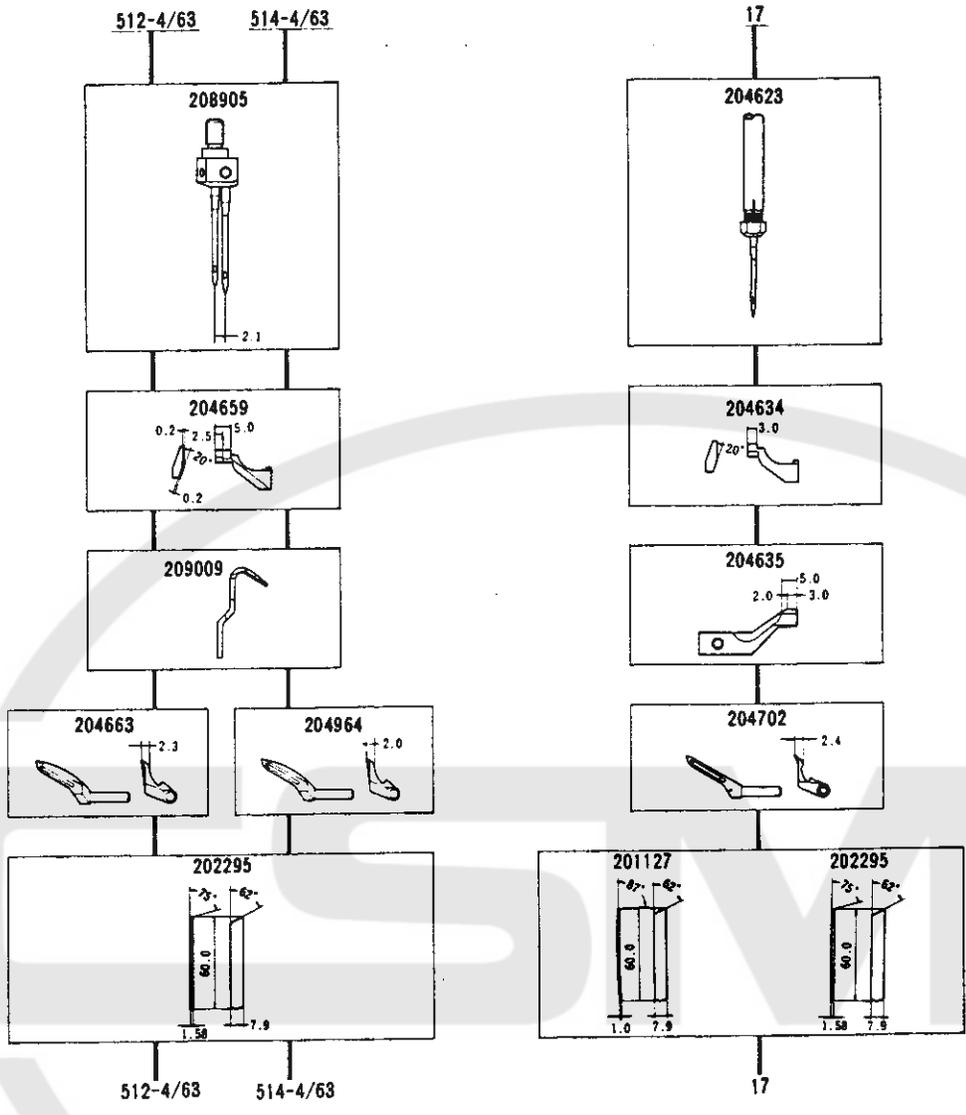

MACHINE TYPE	GAUGE		NEEDLE	MAIN	DIFF.	PRESSER FOOT		UPPER	UPPER	LOWER	401	(401) NEEDLE GUARD		NEEDLE	UPPER	LOWER	NEEDLE
	NG	SW	PLATE	FEED DOG	FEED DOG	COMP.	FAB. GRD.	LOOPER	SPREADER	LOOPER	LOOPER	FRONT	REAR	HOLDER	KNIFE	KNIFE	SIZE
516(515) -4/26	2	3	204343A	208063	208215	208500	208531	204062 #2	204278 #1	204072	204314A	204536	204521	208908	201121A	204161	DCX27 #11
	2	4	204344A	"	"	"	"	"	"	"	"	"	"	"	"	"	"
	2	5	204345A	"	"	"	"	"	"	"	"	"	"	"	"	"	"
	2	6	204346A	"	"	"	"	"	"	"	"	"	"	"	"	"	"
	3	3	204294B	208063	208215	208501	208531	204702 #4	204704 #3	204072	204314A	204536	204521	208909	201121A	204161	DCX27 #14
	3	4	204039B	"	"	"	"	"	"	"	"	"	"	"	"	"	"
	3	5	204252B	"	"	"	"	"	"	"	"	"	"	"	"	"	"
	3	6	204295B	"	"	"	"	"	"	"	"	"	"	"	"	"	"
	5	3	204358A	208063	208215	208502	208531	204702 #4	204704 #3	204072	204431	204042	204522	208910	201121A	204161	DCX27 #14
	5	4	204359A	"	"	"	"	"	"	"	"	"	"	"	"	"	"
	5	5	204360A	"	"	"	"	"	"	"	"	"	"	"	"	"	"
	5	6	204361A	"	"	"	"	"	"	"	"	"	"	"	"	"	"
516(515) -4/27	2	3	204362	208065	208218	208503	208531	204062 #2	204278 #1	204072	204314A	204536	205421	208908	202527A	204161	DCX27 #11
	2	4	204363	"	"	"	"	"	"	"	"	"	"	"	"	"	"
	2	5	204364	"	"	"	"	"	"	"	"	"	"	"	"	"	"
	2	6	204365	"	"	"	"	"	"	"	"	"	"	"	"	"	"
	3	3	204366	208065	208218	208504	208531	204062 #2	204278 #1	204072	204314A	204536	205421	208909	202527A	204161	DCX27 #11
	3	4	204367	"	"	"	"	"	"	"	"	"	"	"	"	"	"
516(515) -4/28	2	3	204343A	208062	208216	208500	208531	204062 #2	204278 #1	204072	204314A	204536	205421	208908	201121A	204161	DCX27 #11
	2	4	204344A	"	"	"	"	"	"	"	"	"	"	"	"	"	"
	2	5	204345A	"	"	"	"	"	"	"	"	"	"	"	"	"	"
	2	6	204346A	"	"	"	"	"	"	"	"	"	"	"	"	"	"
	3	3	204294B	208062	208216	208501	208531	204062 #2	204278 #1	204072	204314A	204536	205421	208909	201121A	204161	DCX27 #11
	3	4	204039B	"	"	"	"	"	"	"	"	"	"	"	"	"	"
516(515) -4/29	2	3	204362	208066	208219	208503	208531	204062 #2	204278 #1	204072	204314A	204536	204521	208908	202527A	204161	DCX27 #11
	2	4	204363	"	"	"	"	"	"	"	"	"	"	"	"	"	"
	2	5	204364	"	"	"	"	"	"	"	"	"	"	"	"	"	"
	2	6	204365	"	"	"	"	"	"	"	"	"	"	"	"	"	"
	3	3	204366	208066	208219	208504	208531	204702 #4	204704 #3	204072	204314A	204536	204521	208909	202527A	204161	DCX27 #14
	3	4	204367	"	"	"	"	"	"	"	"	"	"	"	"	"	"
516(515) -4/30	2	3	204370	208069	208222	208500	208531	204062 #2	204278 #1	204072	204314A	204536	204521	208908	201121A	204161	DCX27 #11
	2	4	204371	"	"	"	"	"	"	"	"	"	"	"	"	"	"
	2	5	204372	"	"	"	"	"	"	"	"	"	"	"	"	"	"
	2	6	204373	"	"	"	"	"	"	"	"	"	"	"	"	"	"
	3	3	204374	208069	208222	208501	208531	204702 #4	204704 #3	204072	204314A	204536	204521	208909	201121A	204161	DCX27 #14
	3	4	204375	"	"	"	"	"	"	"	"	"	"	"	"	"	"
	3	5	204376	"	"	"	"	"	"	"	"	"	"	"	"	"	"
	3	6	204377	"	"	"	"	"	"	"	"	"	"	"	"	"	"
	5	3	204378	208063	208224	208502	208531	204702 #4	204704 #3	204072	204431	204042	204522	208910	201121A	204161	DCX27 #14
	5	4	204379	"	"	"	"	"	"	"	"	"	"	"	"	"	"
	5	5	204380	"	"	"	"	"	"	"	"	"	"	"	"	"	"
	5	6	204381	"	"	"	"	"	"	"	"	"	"	"	"	"	"

COMMON GAUGE PARTS

- 204782 Overlock needle guard (front)
- 204781 Overlock needle guard (rear)



MACHINE	GAUGE		NEEDLE	MAIN	DIFF.	PRESSER FOOT		UPPER	UPPER	LOWER	401	(401) NEEDLE GUARD		NEEDLE	UPPER	LOWER	NEEDLE	
	TYPE	NG	SW	PLATE	FEED DOG	FEED DOG	COMP.	FAB. GRD.	LOOPER	SPREADER	LOOPER	LOOPER	FRONT	REAR	HOLDER	KNIFE	KNIFE	SIZE
516(515) -4/31	2	3	204370	208070	208223	208500	208531	204702 #4	204704 #3	204072	204314A	204536	204521	208908	201121A	204161	DCX27 #16	
		4	204371	"	"	"	"	"	"	"	"	"	"	"	"	"	"	
		5	204372	"	"	"	"	"	"	"	"	"	"	"	"	"	"	"
		6	204373	"	"	"	"	"	"	"	"	"	"	"	"	"	"	"
	3	3	204374	208070	208223	208501	208531	204702 #4	204704 #3	204072	204314A	204536	204521	208909	201121A	204161	DCX27 #16	
		4	204375	"	"	"	"	"	"	"	"	"	"	"	"	"	"	"
		5	204376	"	"	"	"	"	"	"	"	"	"	"	"	"	"	"
		6	204377	"	"	"	"	"	"	"	"	"	"	"	"	"	"	"
	5	3	204378	208064	208225	208502	208531	204702 #4	204704 #3	204072	204431	204042	204522	208910	201121A	204161	DCX27 #16	
		4	204379	"	"	"	"	"	"	"	"	"	"	"	"	"	"	"
		5	204380	"	"	"	"	"	"	"	"	"	"	"	"	"	"	"
		6	204381	"	"	"	"	"	"	"	"	"	"	"	"	"	"	"
516(515) -4/32	3	3	204366	208067	208220	208504	208531	204702 #4	204704 #3	204072	204314A	204536	204521	208909	201121A	204161	DCX27 #16	
		4	204367	"	"	"	"	"	"	"	"	"	"	"	"	"	"	
		5	204368	"	"	"	"	"	"	"	"	"	"	"	"	"	"	
		6	204369	"	"	"	"	"	"	"	"	"	"	"	"	"	"	
516(515) -4/33	3	3	204294B	208064	208217	208501	208531	204702 #4	204704 #3	204072	204314A	204536	204521	208909	201121A	204161	DCX27 #16	
		4	204039B	"	"	"	"	"	"	"	"	"	"	"	"	"	"	
		5	204252B	"	"	"	"	"	"	"	"	"	"	"	"	"	"	
		6	204295B	"	"	"	"	"	"	"	"	"	"	"	"	"	"	
	5	3	204358A	208064	208217	208502	208531	204702 #4	204704 #3	204072	204431	204042	204522	208910	201121A	204161	DCX27 #16	
		4	204359A	"	"	"	"	"	"	"	"	"	"	"	"	"	"	
		5	204360A	"	"	"	"	"	"	"	"	"	"	"	"	"	"	
		6	204361A	"	"	"	"	"	"	"	"	"	"	"	"	"	"	
516(515) -4/37	2	3	204370	208068	208221	208500	208531	204062 #2	204278 #1	204072	204314A	204536	204521	208908	201121A	204161	DCX27 #11	
		4	204371	"	"	"	"	"	"	"	"	"	"	"	"	"	"	
		5	204372	"	"	"	"	"	"	"	"	"	"	"	"	"	"	
		6	204373	"	"	"	"	"	"	"	"	"	"	"	"	"	"	
	3	3	204374	208068	208221	208501	208531	204062 #2	204278 #1	204072	204314A	204536	204521	208909	201121A	204161	DCX27 #11	
		4	204375	"	"	"	"	"	"	"	"	"	"	"	"	"	"	
		5	204376	"	"	"	"	"	"	"	"	"	"	"	"	"	"	
		6	204377	"	"	"	"	"	"	"	"	"	"	"	"	"	"	
516(515) -4/38	2	3	204935	208074	204420	208507	208532	204062 #2	204278 #1	204072	204314A	204536	204521	208908	201121A	204161	DCX27 #11	
		4	204936	"	"	"	"	"	"	"	"	"	"	"	"	"	"	
		5	204937	"	"	"	"	"	"	"	"	"	"	"	"	"	"	
		6	204938	"	"	"	"	"	"	"	"	"	"	"	"	"	"	
	3	3	204939	208074	204420	208508	208532	204702 #4	204704 #3	204072	204314A	204536	204521	208909	201121A	204161	DCX27 #14	
		4	204940	"	"	"	"	"	"	"	"	"	"	"	"	"	"	
		5	204941	"	"	"	"	"	"	"	"	"	"	"	"	"	"	
		6	204942	"	"	"	"	"	"	"	"	"	"	"	"	"	"	
	5	3	204943	208076	204422	208509	208532	204702 #4	204704 #3	204072	204431	204042	204522	208910	201121A	204161	DCX27 #14	
		4	204944	"	"	"	"	"	"	"	"	"	"	"	"	"	"	
		5	204945	"	"	"	"	"	"	"	"	"	"	"	"	"	"	
		6	204946	"	"	"	"	"	"	"	"	"	"	"	"	"	"	

COMMON GAUGE PARTS

- 204782 Overlock needle guard (front)
- 204781 Overlock needle guard (rear)



MACHINE TYPE	GAUGE		NEEDLE PLATE	MAIN FEED DOG	DIFF. FEED DOG	PRESSER FOOT		UPPER LOOPER	UPPER SPREADER	LOWER LOOPER	401 LOOPER	(401) NEEDLE GUARD		NEEDLE HOLDER	UPPER KNIFE	LOWER KNIFE	NEEDLE SIZE					
	NG	SW				COMP.	FAB. GRD					FRONT	REAR									
516(515) -4/39	2	3	204935	208075	204421	208507	208532	204702 #4	204704 #3	204072	204314A	204536	204521	208908	201121A	204161	DCX27 #16					
	2	4	204936	"	"	"	"	"	"	"	"	"	"	"	"	"		DCX27 #16				
	2	5	204937	"	"	"	"	"	"	"	"	"	"	"	"	"			DCX27 #16			
	2	6	204938	"	"	"	"	"	"	"	"	"	"	"	"	"				DCX27 #16		
	3	3	204939	208075	204421	208508	208532	204702 #4	204704 #3	204072	204314A	204536	204521	208909	201121A	204161					DCX27 #16	
	3	4	204940	"	"	"	"	"	"	"	"	"	"	"	"	"						DCX27 #16
	3	5	204941	"	"	"	"	"	"	"	"	"	"	"	"	"	DCX27 #16					
	3	6	204942	"	"	"	"	"	"	"	"	"	"	"	"	"		DCX27 #16				
	516(515) -4/51	5	3	204943	208077	204423	208509	208532	204702 #4	204704 #3	204072	204431	204042	204522	208910	201121A			204161			
		5	4	204944	"	"	"	"	"	"	"	"	"	"	"	"			"	DCX27 #19		
	516(515) -4/52	5	5	204528	208064	208217	208955	204683	204703 #6	204705 #5	204072	204431-HC	204042	204522	208910	201121A			204161		DCX27 #19	
		5	6	204529	"	"	"	"	"	"	"	"	"	"	"	"			"	DCX27 #9		
516(515) -4/91	8	5	208883	208063	208224	208888	-----	204702 #4	204704 #3	204072	204431	204042	204522	208966	201121A	204161	DCX27 # 9					

COMMON GAUGE PARTS

- 204782 Overlock needle guard (front)
- 204781 Overlock needle guard (rear)



MACHINE TYPE	GAUGE		NEEDLE PLATE	MAIN FEED DOG	DIFF. FEED DOG	PRESSER FOOT		UPPER LOOPER	UPPER SPREADER	LOWER LOOPER	401 LOOPER	(401) NEEDLE GUARD		NEEDLE HOLDER	UPPER KNIFE	LOWER KNIFE	NEEDLE SIZE
	NG	SW				COMP.	FAB. GRD					FRONT	REAR				
516-355	3	2	208674	208066	208219	208649	208531	204963 #8	-----	204072	204314A	204536	204521	208965	201121A	204161	DCX27 #11
	3	4	208648	"	"	"	"	"	"	"	"	"	"	"	"	"	
516-555	5	2	208675	208063	208215	209255	208531	204963 #8	-----	204072	204431	204042	204522	209254	201121A	204161	DCX27 #11
	5	4	208676	"	"	"	"	"	"	"	"	"	"	"	"	"	
516-359	3	2	208674	208066	208219	208649	208531	204702 #4	-----	204072	204314A	204536	204521	208965	201121A	204161	DCX27 #11
	3	4	208648	"	"	"	"	"	"	"	"	"	"	"	"	"	
516-559	5	2	208675	208063	208215	209255	208531	204702 #4	-----	204072	204431	204042	204522	209254	201121A	204161	DCX27 #11
	5	4	208676	"	"	"	"	"	"	"	"	"	"	"	"	"	

COMMON GAUGE PARTS

- 209009 Movable needle guard
- 209159 Overlock needle guard (front)



MACHINE TYPE	GAUGE		NEEDLE	MAIN FEED DOG	DIFF. FEED DOG	PRESSER FOOT		UPPER LOOPER	UPPER SPREADER	LOWER LOOPER	401 LOOPER	(401) NEEDLE GUARD		NEEDLE HOLDER	UPPER KNIFE	LOWER KNIFE	NEEDLE SIZE
	NG	SW	PLATE			COMP.	FAB. GRD.					FRONT	REAR				
516(515) -4/38P1	3	4	204940	208074	204420	204502A	204460	204702 #4	204704 #3	204072	204314A	204536	204521	208909	201121A	204161	DCX27 #14
	3	5	204941	"	"	"	"	"	"	"	"	"	"	"	"	"	
516(515) -4/38P2	3	4	204940	208074	204420	204502A	204460	204702 #4	204704 #3	204072	204314A	204536	204521	208909	201121A	204161	DCX27 #14
	3	5	204941	"	"	"	"	"	"	"	"	"	"	"	"	"	
516(515) -4/38P1	3	3	204939	208075	204421	208508	208532	204702 #4	204704 #3	204072	204314A	204536	204521	208909	201121A	204161	DCX27 #16
	3	4	204940	"	"	"	"	"	"	"	"	"	"	"	"	"	
	3	5	204941	"	"	"	"	"	"	"	"	"	"	"	"	"	
	3	6	204942	"	"	"	"	"	"	"	"	"	"	"	"	"	
516(515) -4/38P2	5	3	204943	208077	204423	208509	208532	204702 #4	204704 #3	204072	204431	204042	204522	208910	201121A	204161	DCX27 #16
	5	4	204944	"	"	"	"	"	"	"	"	"	"	"	"	"	
	5	5	204945	"	"	"	"	"	"	"	"	"	"	"	"	"	
	5	6	204946	"	"	"	"	"	"	"	"	"	"	"	"	"	
516(515) -4/38P2	3	3	204939	208075	204421	208508	208532	204702 #4	204704 #3	204072	204314A	204536	204521	208909	201121A	204161	DCX27 #16
	3	4	204940	"	"	"	"	"	"	"	"	"	"	"	"	"	
	3	5	204941	"	"	"	"	"	"	"	"	"	"	"	"	"	
	3	6	204942	"	"	"	"	"	"	"	"	"	"	"	"	"	
516(515) -4/38P2	5	3	204943	208077	204423	208509	208532	204702 #4	204704 #3	204072	204431	204042	204522	208910	201121A	204161	DCX27 #16
	5	4	204944	"	"	"	"	"	"	"	"	"	"	"	"	"	
	5	5	204945	"	"	"	"	"	"	"	"	"	"	"	"	"	
	5	6	204946	"	"	"	"	"	"	"	"	"	"	"	"	"	
516 -4/550	3	4	209195	208066	208219	208998	208531	204062 #2	-----	204072	204314A	204536	204521	208909	202527A	204161	DCX27 #11
	3	5	208993	"	"	"	"	"	-----	"	"	"	"	"	"	"	
516 -4/551	3	4	209196	208063	208215	209202	208531	204062 #2	-----	204072	204314A	204536	204521	208909	201121A	204161	DCX27 #11
	3	5	209197	"	"	"	"	"	-----	"	"	"	"	"	"	"	
	5	4	209198	"	"	209204	"	"	-----	"	204431	204042	204522	208910	"	"	
	5	5	209199	"	"	"	"	"	-----	"	"	"	"	"	"	"	

COMMON GAUGE PARTS

- 204782 Overlock needle guard (front)
- 204781 Overlock needle guard (rear)

GAUGE PARTS LIST

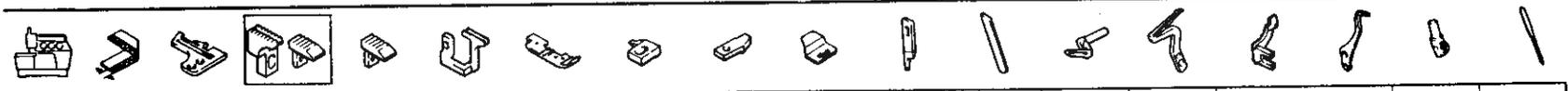

MACHINE TYPE	GAUGE		NEEDLE PLATE	MAIN FEED DOG	AUX. FEED DOG	DIFF. FEED DOG	PRESSER FOOT				UPPER KNIFE	LOWER KNIFE	UPPER LOOPER	LOWER LOOPER	NEEDLE GUARD		NEEDLE BAR. COMP.	NEEDLE
	NG	SW					BODY	FINGER	FAB. GRD	UNCURLER					FRONT	REAR		
505-4/25	2		202816	208090	204674	204730	201152E	201155C	-----	210584	201121A	202295	204062 #2	204072	204634	204635	204623	DCX27 # 9
	3		202817	"	"	"	"	"	-----	"	"	"	"	"	"	"	"	
	4		202818	"	"	"	"	"	-----	"	"	"	"	"	"	"	"	
	5		204913	"	"	"	"	"	-----	"	"	"	"	"	"	"	"	
504-4/19	2		202816	208090	204674	204730	201473B	201224B	-----	210584	201121A	202295	204062 #2	204072	204634	204635	204623	DCX27 # 9
	3		202817	"	"	"	"	"	-----	"	"	"	"	"	"	"	"	
	4		202818	"	"	"	"	"	-----	"	"	"	"	"	"	"	"	
	5		204913	"	"	"	"	"	-----	"	"	"	"	"	"	"	"	
503-4/44	3		205320	208334	208338	204907	202799	201224B	201265B	210584	201121A	202295	204704 #3	204072	204634	204635	204623	DCX27 #14
	4		205321	"	"	"	"	"	"	"	"	"	"	"	"	"	"	
	5		205322	"	"	"	"	"	"	"	"	"	"	"	"	"	"	
	6		205323	"	"	"	"	"	"	"	"	"	"	"	"	"	"	
504-4/16S2	1.5		205465	208911	208912	204730	201230C	205525	201265B	204668	201121A	202295	204062 #2	204072	204634	204635	204623	DCX27 #11
504-4/7	3		202542E	208078	204674	204676	201230C	201224B	201265B	204668	201121A	201127	204062 #2	204072	204634	204635	204623	DCX27 #11
	4		202546E	"	"	"	"	"	"	"	"	202295	"	"	"	"	"	
	5		202596E	"	"	"	"	"	"	"	"	"	"	"	"	"	"	
	6		202597E	"	"	"	"	"	"	"	"	"	"	"	"	"	"	
503-4/48	3		205324	208335	208338	204690	202799	201224B	201265B	210584	201121A	201127	204704 #3	204072	204634	204635	204623	DCX27 #14
	4		205325	"	"	"	"	"	"	"	"	202295	"	"	"	"	"	
	5		205326	"	"	"	"	"	"	"	"	"	"	"	"	"	"	
	6		205327	"	"	"	"	"	"	"	"	"	"	"	"	"	"	
504-4/17	3		205324	208087	204677	204724	205135	-----	-----	210584	201121A	201127	204702 #4	204072	204634	204635	204623	DCX27 #14
	4		205325	"	"	"	205136	-----	-----	"	"	202295	"	"	"	"	"	
	5		205326	"	"	"	"	-----	-----	"	"	"	"	"	"	"	"	
	6		205327	"	"	"	"	-----	-----	"	"	"	"	"	"	"	"	

GAUGE PARTS LIST



MACHINE TYPE	GAUGE		NEEDLE PLATE	MAIN FEED DOG	AUX. FEED DOG	DIFF. FEED DOG	PRESSER FOOT				UPPER KNIFE	LOWER KNIFE	UPPER LOOPER	LOWER LOOPER	NEEDLE GUARD		NEEDLE BAR. COMP.	NEEDLE	
	NG	SW					BODY	FINGER	FAB. GRD	UNCURLER					FRONT	REAR			
504-4/66	3		202542E	208080	204674	204691	201230C	201224B	201265B	204668	201121A	201127	204702 #4	204072	204634	204635	204623	DCX27 #14	
	4		202546E	"	"	"	"	"	"	"	"	"	"	"	"	"	"		
	5		202596E	"	"	"	"	"	"	"	"	202295	"	"	"	"	"		
	6		202597E	"	"	"	"	"	"	"	"	"	"	"	"	"	"		
504-4/65	3		202542E	208080	204674	204679	201230C	201224B	201265B	204668	201121A	201127	204703 #6	204072	204634	204635	204623	DCX27 #18	
	4		202546E	"	"	"	"	"	"	"	"	"	"	"	"	"	"		
	5		202596E	"	"	"	"	"	"	"	"	202295	"	"	"	"	"		
	6		202597E	"	"	"	"	"	"	"	"	"	"	"	"	"	"		
	7		204797	"	"	"	"	"	"	"	"	"	"	"	"	"	"		
	8		204731	"	"	"	"	"	"	"	"	"	"	"	"	"	"		
	3		202542E	208078	204674	204690	201230C	201224B	201265B	204668	201121A	201127	204062 #2	204072	204634	204635	204623		DCX27 #11
	4		202546E	"	"	"	"	"	"	"	"	"	"	"	"	"	"		
5		202596E	"	"	"	"	"	"	"	"	202295	"	"	"	"	"			
6		202597E	"	"	"	"	"	"	"	"	"	"	"	"	"	"			
504-4/21	3		202542E	208086	204674	204724	205135	-----	-----	210584	201121A	201127	204062 #2	204072	204634	204635	204623	DCX27 #11	
	4		202546E	"	"	"	205136	-----	-----	"	"	"	"	"	"	"	"		
	5		202596E	"	"	"	"	-----	-----	"	"	202295	"	"	"	"	"		
	6		202597E	"	"	"	"	-----	-----	"	"	"	"	"	"	"	"		
504-4/43	3		205235	208085	204677	204722	205252	201224B	201265B	210584	201121A	201127	204702 #4	204072	204634	204635	204623	DCX27 #14	
	4		205236	"	"	"	"	"	"	"	"	"	"	"	"	"	"		
	5		205237	"	"	"	"	"	"	"	"	202295	"	"	"	"	"		
	6		205238	"	"	"	"	"	"	"	"	"	"	"	"	"	"		
504-4/45	3		205320	208083	204677	204693	202799	201224B	201265B	210584	201121A	201127	204702 #4	204072	204634	204635	204623	DCX27 #14	
	4		205321	"	"	"	"	"	"	"	"	"	"	"	"	"	"		
	5		205322	"	"	"	"	"	"	"	"	202295	"	"	"	"	"		
	6		205323	"	"	"	"	"	"	"	"	"	"	"	"	"	"		
504-4/47	3		205324	208079	204677	204676	205253	201224B	201265B	210584	201121A	201127	204702 #4	204072	204634	204635	204623	DCX27 #16	
	4		205325	"	"	"	"	"	"	"	"	"	"	"	"	"	"		
	5		205326	"	"	"	"	"	"	"	"	202295	"	"	"	"	"		
	6		205327	"	"	"	"	"	"	"	"	"	"	"	"	"	"		
504-4/260	5		209257	209293	204674	-----	209226	-----	-----	-----	201121A	202295	204703 #6	204072	204634	204635	204623	DCX27 #18	
	6		209224	"	"	-----	"	-----	-----	"	"	"	"	"	"	"	"		

GAUGE PARTS LIST



MACHINE TYPE	GAUGE		NEEDLE PLATE	MAIN FEED DOG	AUX. FEED DOG	DIFF. FEED DOG	PRESSER FOOT				UPPER KNIFE	LOWER KNIFE	UPPER LOOPER	LOWER LOOPER	NEEDLE GUARD		NEEDLE HOLDER	NEEDLE			
	NG	SW					BODY	FINGER	FAB. GRD	UNCURLER					FRONT	REAR					
514-4/68	2	2	208753 205255 202554E	208078	204674	204690	208730	208731	208735	204668	201121A	201127 202295	204963 # 8	204072	204659	209009	208905	DCX27 #11			
	2	3					"	"	"	"	"	"	"	"	"	"	"	"	"	"	"
	2	4					"	"	"	"	"	208732	"	"	"	"	"	"	"	"	"
514-4/61	2	2	208753 205255 202554E	208078	204674	204676	208730	208731	208735	204668	201121A	201127 202295	204949 #11	204072	204659	209009	208905	DCX27 # 9			
	2	3					"	"	"	"	"	"	"	"	"	"	"	"	"	"	"
	2	4					"	"	"	"	"	208732	"	"	"	"	"	"	"	"	"
514-4/18	2	2	208753 205255 202554E	208078	204674	204690	208730	209171	208735	204668	201121A	201127 202295	204663 # 7	204072	204659	209009	208905	DCX27 #11			
	2	3					"	"	"	"	"	"	"	"	"	"	"	"	"	"	"
	2	4					"	"	"	"	"	208651	"	"	"	"	"	"	"	"	"
514-4/18S1	2	2	208753 205255 202554E	208080	204674	204691	208730	209171	208735	204668	201121A	201127 202295	204990 #12	204991	204659	209009	208905	DCX27 #14			
	2	3					"	"	"	"	"	"	"	"	"	"	"	"	"	"	"
	2	4					"	"	"	"	"	208651	"	"	"	"	"	"	"	"	"
514-4/18S2	2	2	208753 205255 202554E	208078	204674	204690	208730	209171	208735	204668	201121A	201127 202295	204990 #12	204991	204659	209009	208905	DCX27 #14			
	2	3					"	"	"	"	"	"	"	"	"	"	"	"	"	"	"
	2	4					"	"	"	"	"	208651	"	"	"	"	"	"	"	"	"
514-4/67	2	2	208753 205255 202554E	208080	204674	204691	208730	208731	208735	204668	201121A	201127 202295	204964 # 9	204072	204659	209009	208905	DCX27 #14			
	2	3					"	"	"	"	"	"	"	"	"	"	"	"	"	"	"
	2	4					"	"	"	"	"	208732	"	"	"	"	"	"	"	"	"
514-4/73	2.5	2.5	208030 208031	208093	204674	208044	208730	208733 208734	208735	204668	201121A	201127 202295	204964 # 9	204072	208051	209009	208906	DCX27 #14			
	2.5	4					"	"	"	"	"	"	"	"	"	"	"	"	"	"	"
	2.5	4					"	"	"	"	"	"	"	"	"	"	"	"	"	"	"
514-4/20	1.5	2	204910 204911 205256 205257	208090	204674	204730	201230C	201396B	201265B	204668	201121A	202295	204949 #11	204072	204659	209009	208904	DCX3 # 9			
	1.5	3					"	"	"	"	"	"	"	"	"	"	"	"	"	208905	DCX27 # 9
	2	2					"	"	"	"	"	"	"	"	"	"	"	"	"	"	"
514-4/62	2	2	208753 205255 205254E	208086	204674	204724	205136	-----	-----	210584	201121A	201127 202295	204964 # 9	204072	204659	209009	208905	DCX27 #14			
	2	3					"	"	"	"	"	"	"	"	"	"	"	"	"	"	"
	2	4					"	"	"	"	"	"	"	"	"	"	"	"	"	"	"
514-4/64	2	4	205243	204679	204677	204676	205253	201310A	201265B	210584	201121A	202295	204964 # 9	204072	204659	209009	208905	DCX27 #14			
	2	5					205244	208087	204677	204724	205136	-----	-----	210584	201121A	202295	204964 # 9	204072	204659	209009	208905

GAUGE PARTS LIST

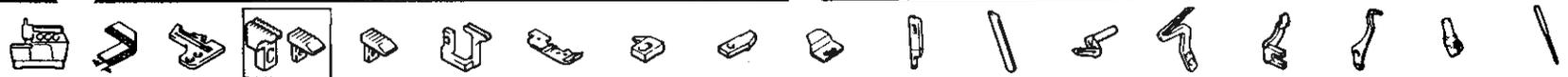

MACHINE TYPE	GAUGE		NEEDLE	MAIN	AUX.	DIFF.	PRESSER FOOT				UPPER	LOWER	UPPER	LOWER	NEEDLE GUARD		NEEDLE	NEEDLE
	NG	SW	PLATE	FEED DOG	FEED DOG	FEED DOG	BODY	FINGER	FAB. GRD	UNCURLER	KNIFE	KNIFE	LOOPER	LOOPER	FRONT	REAR	HOLDER	NEEDLE
504-4/21P1 504-4/21P2	5		205326	208087	204677	204724	208783	-----	-----	210584	201121A	202295	204062 # 2	204072	204634	204635	204623	DCX27 #11
514-4/62P1 514-4/62P2	2 3 2 4		209355 205243	208087 "	204677 "	204724 "	208782 "	----- -----	----- -----	210584 "	201121A "	202295 "	204964 # 9 "	204072 "	204659 "	209009 "	208905 "	DCX27 #14
514-4/64P1 514-4/64P2	2 4		205243	208079	204677	204676	211873-TA	211875-TA	-----	-----	201121A	202295	204964 # 9	204072	204659	209009	208905	DCX27 #14
504-4/47P1 504-4/47P2	3 4 5		205324 205325 205326	208079 " "	204677 " "	204676 " "	211873-TA 212271-TA 211874-TA	----- ----- -----	----- ----- -----	201121A " "	201127 " 202295	204702 # 4 " "	204072 " "	204634 " "	204635 " "	204623 " "	DCX27 #16	
504-4/350P1 504-4/350P2	5		205326	209325-BF	209327-BF	209328-BF	209333-TA	211874-TA	-----	-----	201121A	202295	204062 # 2	204072	204634	204635	204623	DCX27 #11
514-4/351P1 514-4/351P2	2 4		205243	209325-BF	209327-BF	209328-BF	209333-TA	211875-TA	-----	-----	201121A	202295	204963 # 8	204072	204659	209009	208905	DCX27 #11



**NEEDLE SIZE AND
UPPER LOOPER/SPREADER**

Use Upper Looper/Spreader according to
the needle size and stitch type as shown.

STITCH TYPE	NEEDLE SIZE	PART NO.	USED FOR
503 515	9-12	204278 (#1)	2-thread L52.
	13-16	204704 (#3)	
	17-21	204705 (#5)	4-thread L32.
504 505 516	9-12	204062 (#2)	3-thread L52.
	13-16	204702 (#4)	
	17-21	204703 (#6)	5-thread L32.
514	9-12	204963 (#8)	2-needle L52.
	13-16	204964 (#9)	
	17-21	204965 (#10)	
512	9-12	204702 (#4)	2-needle L52 (mock-safety stitch)
	13-16	204663 (#7)	
	17-21	204949 (#11)	

**LIST OF THE COMPONENT PARTS
FOR MAIN FEED DOG COMPLETE**

**503-4. 504-4. 505-4.
512-4. 514-4.**

515-4. 516-4.

Main feed dog complete	Component parts			Main feed dog complete	Component parts		
	Main feed dog	Aux. feed dog	Screw		Main feed dog	Aux. feed dog	Screw
208078	204675A	204674	2922	208062	204125B	204424	2922
208078-BF	204675A-BF	204674	"	208063	204248B	208059	"
208079	204675A	204677	"	208064	204394	208059	"
208079-BF	204675A-BF	204677	"	208065	204395	204425	"
208080	204678A	204674	"	208066	204396	208060	"
208080-BF	204678A-BF	204674	"	208067	204397	208060	"
208082-BF	204692A-BF	204674	"	208068	204398	204427	"
208083	204692A	204677	"	208069	204399	208061	"
208083-BF	204692A-BF	204677	"	208070	204400	208061	"
208084	204694A	204677	"	208071	204401	204424	"
208085-BF	204721A-BF	204677	"	208072	204402	208059	"
208086	204723A	204674	"	208073	204403	208059	"
208087	204723A	204677	"	208074	204931	208061	"
208088	204725A	204677	"	208075	204932	208061	"
208089	204727A	204677	"	208076	204933	208059	"
208090-BF	204729A-BF	204674	"	208077	204934	208059	"
208091	208039	204674	"				
208092	208039	208095	"				
208092-BF	208039A-BF	208095	"				
208093-BF	208040-BF	204674	"				
208167	208040	208095	"				
208334	208336	208338	"				
208335	208337	208338	"				
208911	204729A	208912	"				
209293	209225	204674	"				
209325-BF	209326-BF	209327-BF	"				
209329-BF	209330-BF	209327-BF	"				
209383-BF	209384-BF	208095	"				
210415-16	209416-16	208095	"				

INDEX

PART NO.	PFAFF-NO	PAGE	NO. REF.	PART NO.	PFAFF-NO	PAGE	NO. REF.	PART NO.	PFAFF-NO	PAGE	NO. REF.
DCX27 # 9		126		409	09-009 732-50	51	14	1457	09-009 048-64	9	13
DCX27 # 9		128		409	09-009 732-50	53	28	1457	09-009 048-64	17	20
DCX27 # 9		130		409	09-009 732-50	55	37	1457	09-009 048-64	31	5
DCX27 #11		124		410-JA	09-009 813-01	51	16	1457	09-009 048-64	41	18
DCX27 #11		125		410-JA	09-009 813-01	53	30	1457-1	09-009 048-65	41	25
DCX27 #11		126		410-JA	09-009 813-01	55	39	1457-1	09-009 048-65	59	19
DCX27 #11		127		413	09-009 732-52	51	18	1458	09-009 048-66	39	4
DCX27 #11		128		413	09-009 732-52	53	32	1459	09-009 053-73	9	34
DCX27 #11		128		413	09-009 732-52	55	41	1459	09-009 053-73	13	4
DCX27 #11		129		452	09-009 833-34	71	1	1459	09-009 053-73	15	7
DCX27 #11		130									
DCX27 #11		131		467	09-009 803-71	57	18	1459	09-009 053-73	65	14
DCX27 #11		132		468	09-009 803-73	57	20	1732	09-009 048-67	9	18
DCX27 #14		124		480	09-009 815-09	71	18	1732-HC	09-009 833-35	19	30
DCX27 #14		125		482	09-400 028-00	71	23	1998-2	09-009 048-69	25	16
DCX27 #14		127		484	09-400 029-00	71	3	2022	09-009 051-60	3	20
DCX27 #14		128		485	09-400 030-00	71	2	2022	09-009 051-60	11	19
DCX27 #14		129		486A9C	09-009 612-04	69		2022-4	09-009 051-78	13	12
DCX27 #14		130		486B9C	09-400 773-00	69		2022-4	09-009 051-78	13	15
DCX27 #14		131		486C9C	09-400 774-00	69		2022-4	09-009 051-78	15	12
DCX27 #14		132		502-CA	09-009 815-14	69	15	2022-4	09-009 051-78	15	15
DCX27 #16		125		503-CA	09-009 815-12	69	1	2022-4	09-009 051-78	17	13
DCX27 #16		126		504-CA	09-009 815-15	69	16	2022-4	09-009 051-78	41	12
DCX27 #16		127		505-CA	09-400 781-00	69	4	2133-1	09-009 053-36	35	25
DCX27 #16		129		505ACA	09-400 780-00	69	5	2133-1	09-009 053-36	41	20
DCX27 #16		132		506	09-400 782-00	69	33	2193	09-009 053-37	23	20
DCX27 #18		129		507	09-400 783-00	69	10	2193	09-009 053-37	27	22
DCX27 #19		126		509	09-400 784-00	69	2	2193	09-009 053-37	34	38
DCX3 # 9		130		512	09-400 785-00	69	13	2193	09-009 053-37	43	14
W09070-2	09-009 054-35	17	47	527-CA	09-009 826-63	69	31	2193	09-009 053-37	43	26
127	91-029 007-91	71	10	527ACA	09-009 826-64	69	32	2193	09-009 053-37	53	7
128	91-029 480-91	71	11	613B	09-009 833-26	71	31	2193	09-009 053-37	55	7
131	09-009 815-08	71	16	629B	09-009 833-27	71	25	2193	09-009 053-37	55	27
153	09-009 819-55	71	17	630B	09-009 833-28	71	26	2193	09-009 053-37	61	6
178	09-009 600-03	71	4	631B	09-009 833-29	71	27	2193	09-009 053-37	63	18
179	09-009 071-00	71	12	642B	09-009 833-30	71	30	2193	09-009 054-65	63	9
182	99-631 288-15	71	14	647B	09-009 833-31	71	28	2902	09-009 053-42	7	8
189	09-009 803-67	57	12	656B	09-009 833-32	71	29	2902	09-009 053-42	23	26
192	09-009 600-04	65	21	909	09-009 612-22	71	24	2902	09-009 053-42	27	32
193	09-009 600-05	65	22	1170	09-009 054-61	63	24	2905	09-009 823-33	7	13
194	09-009 600-06	65	23	1170-1	09-009 048-12	11	23	2905	09-009 823-33	25	9
195	09-009 600-07	65	29	1170-1	09-009 048-12	47	17	2905	09-009 823-33	57	7
196	09-009 600-08	65	31	1170-1	09-009 048-12	63	37	2905	09-009 823-33	61	22
197	09-009 600-09	65	32	1170-3	09-009 054-62	17	25	2913-2	09-009 600-20	41	6
198	09-009 600-10	65	36	1175-2	09-009 048-13	11	33	2921	09-009 053-46	23	28
199	09-009 83-33	65	37	1175-2	09-009 048-13	25	5	2921	09-009 053-46	41	27
200	09-009 835-07	71	15	1175-2	09-009 048-13	35	23	2921	09-009 053-46	43	19
232-CA	09-009 619-24	69	23	1175-2	09-009 048-13	39	13	2921	09-009 053-46	43	43
272	09-009 612-01	67	8	1175-2	09-009 048-13	39	32	2921	09-009 053-46	45	7
283	09-009 048-24	71	8	1175-2	09-009 048-13	65	16	2921	09-009 053-46	45	12
284	09-009 048-25	71	7	1175-3	09-009 048-14	5	38	2921	09-009 053-46	45	34
285	09-009 048-26	71	6	1175-3	09-009 048-14	7	17	2921	09-009 053-46	45	36
286	09-009 054-17	71	5	1175-3	09-009 048-14	21	40	2921	09-009 053-46	51	24
293A	09-400 768-00	69	26	1175-3	09-009 048-14	27	29	2922	09-009 065-38	5	25
293B	09-009 823-35	69	27	1175-3	09-009 048-14	35	34	2922	09-009 065-38	29	28
293C	09-400 770-00	69	28	1175-3	09-009 048-14	61	30	2922	09-009 065-38	35	22
322	09-009 815-06	71	13	1175-3	09-009 048-14	63	34	2922	09-009 065-38	43	7
337	09-009 803-63	57	8	1186	09-009 048-15	17	49	2922	09-009 065-38	65	42
338	09-009 803-68	57	15	1189	09-009 054-63	29	26	3044	09-009 053-49	5	9
339	09-009 803-74	57	16	1189	09-009 054-63	35	35	3044	09-009 053-49	7	11
339	09-009 803-74	57	21	1189	09-009 054-63	61	16	3044	09-009 053-49	41	38
340	09-009 803-70	57	17	1196	09-009 048-16	43	25	3044	09-009 053-49	53	12
341	09-009 803-66	57	11	1196	09-009 048-16	55	18	3044	09-009 053-49	55	12
343	09-009 803-72	57	19	1202	09-009 048-17	9	9	3044	09-009 053-49	61	11
344	09-009 803-64	57	9	1202	09-009 048-17	41	9	3044	09-009 053-49	65	25
380A	09-009 807-04	69	6	1202	09-009 048-17	51	3	3056	09-009 606-29	31	6
381-CA	09-009 612-14	69	9	1202	09-009 048-17	53	13	3091	09-009 053-50	5	30
382-CA	09-009 815-13	69	11	1202	09-009 048-17	55	13	3091	09-009 053-50	43	13
383-CA	09-009 815-16	69	19	1202	09-009 048-17	59	44	3091	09-009 053-50	47	18
384	09-009 612-17	69	20	1202	09-009 048-17	61	12	3091	09-009 053-50	61	52
386	09-009 612-19	69	36	1206	09-009 048-19	19	43	3091	09-009 053-50	63	25
391	09-009 800-01	71	9	1206	09-009 048-19	21	42	3119	09-009 053-51	17	37
392	09-009 734-77	71	19	1206	09-009 048-19	29	44	3150	09-009 833-36	45	24
403	09-009 732-44	51	7	1206	09-009 048-19	41	23	4009-1	09-009 053-53	5	15
403	09-009 732-44	51	21	1206	09-009 048-19	59	12	4009-1	09-009 053-53	5	22
403	09-009 732-44	55	30	1206	09-009 048-19	59	14	4009-1	09-009 053-53	5	32
404	09-009 732-45	51	10	1216	09-009 048-20	7	20	4009-1	09-009 053-53	7	4
404	09-009 732-45	53	24	1216	09-009 048-20	9	5	4009-1	09-009 053-53	19	20
404	09-009 732-45	55	33	1216	09-009 048-20	37	23	4009-1	09-009 053-53	21	18
404	09-009 732-46	51	9	1216	09-009 048-20	57	3	4009-1	09-009 053-53	31	30
405	09-009 732-46	53	23	1216	09-009 048-20	61	34	4009-1	09-009 053-53	35	11
405	09-009 732-46	55	32	1229	09-009 048-22	63	15	4009-1	09-009 053-53	39	26
406	09-009 732-47	51	8	1231	09-009 048-09	43	41	4009-1	09-009 053-53	49	13
406	09-009 732-47	53	22	1234	09-009 048-23	5	30	4009-1HC	09-009 833-37	21	28
406	09-009 732-47	55	31	1234	09-009 048-23	59	39	4012	09-009 612-25	51	11
407	09-009 732-48	51	12	1234	09-009 048-23	63	39	4012	09-009 612-25	53	25
407	09-009 732-48	53	26	1234	09-009 048-23	65	49	4012	09-009 612-25	55	34
407	09-009 732-48	55	35	1333	09-009 048-27	53	20	4012	09-009 612-25	69	29
408	09-009 732-49	51	13	1333	09-009 048-27	61	38	4012	09-009 612-25	69	29
408	09-009 732-49	53	27	1435	09-009 048-63	9	33	4014	09-400 786-00	69	21
408	09-009 732-49	55	36	1435	09-009 048-63	59	25	4021	09-400 786-00	69	17

INDEX

PART NO.	PPAFF-NO	PAGE	NO. REF.	PART NO.	PPAFF-NO	PAGE	NO. REF.	PART NO.	PPAFF-NO	PAGE	NO. REF.
4022	09-400 787-00	69	14	5117	09-009 053-88	65	8	5336	09-009 601-19	33	23
4117	09-009 826-65	69	34	5117	09-009 053-88	65	44	5341	09-009 601-20	65	38
4512	09-400 788-00	67	7	5118	09-009 053-89	37	21	5345	09-009 070-23	49	11
4802	09-400 064-00	29	9	5118	09-009 053-89	37	26	5346	09-009 070-23	49	31
4803	09-009 612-30	69	8	5118	09-009 053-89	41	2	5347	09-009 068-79	35	48
4803	09-009 612-30	69	22	5118	09-009 053-89	49	3	5348	09-009 833-38	65	33
4803	09-009 612-30	69	25	5118	09-009 053-89	59	36	5357	09-009 601-22	65	34
4803	09-009 612-30	69	30	5118	09-009 053-89	63	27	5359	09-009 067-95	21	31
4805	09-400 065-00	67	14	5118	09-009 053-89	65	27	5361	09-009 054-05	17	13
4805	09-400 065-00	69	18	5137	09-009 053-91	7	26		09-009 067-79	11	29
4805	09-400 065-00	69	35	5137	09-009 053-91	19	14	5362	09-009 068-30	9	40
4818	09-009 732-56	51	15	5137	09-009 053-91	19	17	5371	09-009 603-27	61	13
4818	09-009 732-56	53	29	5137	09-009 053-91	21	15	5376	09-009 612-37	13	10
4818	09-009 732-56	55	38	5137	09-009 053-91	63	12	5376	09-009 612-37	13	14
4818	09-009 732-56	55	38	5138B	09-009 067-17	47	25	5376	09-009 612-37	15	11
4904	09-009 612-31	67	12	5141	09-009 600-24	37	6	5376	09-009 612-37	15	14
4905	09-009 612-32	67	16	5142	09-009 053-94	21	33	5380	09-009 601-47	64	10
4908	09-009 732-57	53	17	5142	09-009 053-94	61	45	5381	09-009 069-26	17	6
4908	09-009 732-57	53	31	5143A	09-009 600-25	19	8	5381	09-009 069-26	33	4
4908	09-009 732-57	55	40	5143A	09-009 600-25	21	8	5381	09-009 069-26	35	6
4911	09-009 803-65	57	10	5145	09-009 600-26	47	11	5381	09-009 069-26	37	7
5001	09-009 814-58	39	7	5146	09-009 053-95	7	23	5381	09-009 069-26	37	12
5002	09-009 053-54	7	10	5147	09-009 053-96	7	15	5381	09-009 069-26	39	2
5002	09-009 053-54	39	34	5150B	09-009 053-98	47	27	5385	09-009 606-14	29	2
5003	09-009 600-21	43	5	5152	09-009 053-99	5	2	5408	09-009 070-03	25	4
5010	09-009 053-55	19	44	5152	09-009 053-99	59	6	5409	09-009 070-04	43	9
5010	09-009 053-55	49	22	5157	09-009 804-01	33	28	5409	09-009 070-04	45	1
5012	09-009 065-32	19	36	5157	09-009 804-01	45	16	5427	09-009 611-79	33	12
5012	09-009 065-32	25	11	5163	09-009 054-71	3	7	5427	09-009 611-79	43	8
5012	09-009 065-32	49	15	5182	09-009 601-03	9	27	5437	09-009 606-28	33	18
5022	09-009 068-68	9	15	5183	09-009 601-04	65	24	5455	09-009 612-41	31	21
5029	09-009 053-59	19	39	5184	09-009 054-02	53	10	5455	09-009 612-41	35	9
5029	09-009 053-59	37	5	5184	09-009 054-02	55	10	5457	09-009 612-42	29	12
5029	09-009 053-59	41	31	5184	09-009 054-02	61	9	5457	09-009 612-42	31	18
5029	09-009 053-59	59	20	5205	09-009 069-93	35	42	5461	09-009 612-44	33	15
5030	09-009 053-60	43	38	5205	09-009 069-93	35	44	5461	09-009 612-44	33	29
5030	09-009 053-60	45	9	5210	09-009 618-57	51	6	5476	09-009 612-45	69	3
5033	09-009 053-62	9	37	5210	09-009 618-57	59	42	5482	09-009 612-49	5	16
5053	09-009 053-62	17	29	5227	09-009 068-73	19	33	5501	09-009 618-31	19	46
5055	09-009 053-64	47	9	5227	09-009 068-73	19	33	5501	09-009 618-31	21	46
5060	09-009 053-66	63	6	5227	09-009 068-73	63	3	5513	09-009 618-58	59	8
5064	09-009 053-66	63	6	5231	09-009 054-77	35	15	5538	09-009 734-80	43	12
5077	09-009 054-69	31	33	5231	09-009 054-77	35	39	5546	09-009 732-64	23	13
5077	09-009 054-69	51	27	5232	09-009 064-50	9	43	5546	09-009 732-64	27	13
5078	09-009 053-69	3	2	5232	09-009 064-50	41	10	5549	09-009 816-63	11	4
5080	09-009 053-71	11	2	5233	09-009 065-82	13	6	5552	09-009 833-39	43	21
5081	09-009 053-72	11	3	5233	09-009 065-82	13	8	7102	09-400 792-00	64	12
5082A	09-009 053-74	19	12	5233	09-009 065-82	15	7	9050	09-009 815-93	67	13
5082A	09-009 053-74	21	11	5233	09-009 065-82	15	9	137142	09-009 048-30	61	23
5082A	09-009 053-74	23	10	5234	09-009 065-83	17	3	137142	09-009 048-30	65	26
5082A	09-009 053-74	27	10	5237	09-009 068-72	3	6	137142	09-009 048-30	65	28
5084	09-009 053-76	25	27	5239	09-009 054-78	25	22	137906	09-009 048-42	5	40
5084	09-009 053-76	29	8	5240	09-009 067-45	11	24	137906	09-009 048-42	59	40
5084	09-009 053-76	31	14	5242	09-009 601-06	49	2	137906	09-009 048-42	61	31
5084	09-009 053-76	33	6	5259	09-009 054-13	31	25	137906	09-009 048-42	61	35
5084	09-009 053-76	35	2	5260	09-009 054-14	39	22	137906	09-009 048-42	63	40
5084	09-009 053-76	35	27	5267	09-009 601-07	11	7	137906	09-009 048-42	65	50
5084	09-009 053-76	37	14	5271	09-009 601-08	41	37	167066	09-009 601-53	51	4
5088	09-009 053-80	39	18	5276	09-009 601-09	63	29	167066	09-009 601-53	53	14
5089	09-009 053-81	43	35	5284	09-009 067-39	27	25	167066	09-009 601-53	55	14
5089	09-009 053-81	45	29	5284	09-009 067-39	29	23	167066	09-009 601-53	59	45
5089	09-009 053-81	55	26	5286	09-009 054-01	25	23	167066	09-009 601-53	63	35
5091	09-009 067-20	5	12	5291	09-009 065-72	45	20	167072	09-009 054-81	31	10
5091	09-009 067-20	9	24	5292	09-009 064-89	17	18	167077	09-009 054-83	31	7
5091	09-009 067-20	9	30	5292	09-009 064-89	17	35	167079	09-009 605-22	31	2
5091	09-009 067-20	21	35	5292	09-009 064-89	17	40	198192	09-009 605-10	5	33
5091	09-009 067-20	21	37	5292	09-009 064-89	17	50	200030	09-009 601-54	17	21
5091	09-009 067-20	31	3	5292	09-009 064-89	29	5	200041	09-009 054-85	17	45
5094	09-009 053-82	7	2	5292	09-009 064-89	31	27	200098	09-009 048-70	5	10
5094	09-009 053-82	7	25	5292	09-009 064-89	33	11	200098	09-009 048-70	39	23
5094	09-009 053-82	47	22	5292	09-009 064-89	59	26	200136	09-009 054-86	49	7
5104	09-009 600-23	59	10	5299	09-009 067-14	61	25	200152	09-009 069-37	47	2
5104	09-009 600-23	59	23	5304	09-009 618-25	11	20	200152	09-009 069-37	49	8
5104	09-009 600-23	65	11	5312	09-009 601-14	17	14	200155	09-009 065-56	49	6
5107	09-009 605-41	19	34	5316	09-009 601-16	37	9	200155	09-009 065-56	49	26
5113	09-009 054-70	9	26	5317	09-009 601-17	35	30	200162A	09-009 815-02	9	4
5113	09-009 054-70	19	28	5317	09-009 601-17	41	16	200183	09-009 048-77	63	16
5113	09-009 054-70	21	26	5321A	09-009 069-59	37	29	200555	09-009 071-03	7	22
5113	09-009 054-70	31	29	5326	09-009 070-24	63	11	200555	09-009 071-03	19	27
5113	09-009 054-70	31	34	5328	09-009 071-11	7	6	200555	09-009 071-03	21	25
5117	09-009 053-88	3	12	5328	09-009 071-11	17	8	200654	09-009 601-57	17	16
5117	09-009 053-88	5	19	5328	09-009 071-11	29	17	200821	09-009 048-98	7	18
5117	09-009 053-88	11	13	5328	09-009 071-11	43	31	201002	09-009 601-58	3	3
5117	09-009 053-88	39	29	5328	09-009 071-11	45	10	201002	09-009 601-58	3	10
5117	09-009 053-88	39	39	5328	09-009 071-11	45	18	201037	09-009 049-22	19	4
5117	09-009 053-88	53	15	5328	09-009 071-11	45	32	201037	09-009 049-22	21	4

INDEX

PART NO.	PFAFF-NO	PAGE	NO. REF.	PART NO.	PFAFF-NO	PAGE	NO. REF.	PART NO.	PFAFF-NO	PAGE	NO. REF.
201056	09-009 049-35	35	1	202295	09-009 066-42	131		204072	09-009 054-20	130	
201056	09-009 049-35	41	17	202295	09-009 066-42	132		204072	09-009 054-20	131	
201068	09-009 049-44	19	10	202451	09-009 051-81	41	26	204072	09-009 054-20	132	
201068	09-009 049-44	21	10	202495	09-009 070-14	17	44	204084-2	09-009 055-52	33	7
201068	09-009 049-44	23	6	202499E	09-009 051-85	131		204085	09-009 055-53	33	2
201072A	09-009 068-93	23	2	202522	09-009 052-03	33	34	204089	09-009 055-57	31	15
201072A	09-009 068-93	27	2	202522	09-009 052-03	37	10	204091	09-009 055-59	59	31
201074A	09-009 049-48	23	12	202522	09-009 052-03	65	30	204093	09-009 055-61	29	22
201074A	09-009 049-48	27	12	202526	09-009 601-69	3	23	204095A	09-009 055-62	31	26
201086	09-009 049-57	27	6	202527A	09-009 070-82	39	17	204096	09-009 054-30	31	31
201117	09-009 050-05	17	7	202527A	09-009 070-82	124		204097A	09-009 055-63	31	28
201121A	09-009 050-06	39	16	202527A	09-009 070-82	127		204099	09-009 606-31	31	4
201121A	09-009 050-06	124		202542E	09-009 611-31	128		204100	09-009 067-53	33	1
201121A	09-009 050-06	125		202542E	09-009 611-31	129		204107	09-009 067-58	23	19
201121A	09-009 050-06	126		202546E	09-009 611-05	128		204107	09-009 067-58	27	20
201121A	09-009 050-06	127		202546E	09-009 611-05	129		204107	09-009 067-58	35	10
201121A	09-009 050-06	128		202554E	09-009 611-06	130		204111A	09-009 067-57	35	12
201121A	09-009 050-06	129		202554E	09-009 611-06	131		204114	09-009 064-01	35	15
201121A	09-009 050-06	130		202576	09-009 052-60	9	11	204114	09-009 064-01	35	37
201121A	09-009 050-06	131		202588	09-009 052-70	43	36	204115	09-009 064-02	35	14
201121A	09-009 050-06	132		202588	09-009 052-70	51	21	204115	09-009 064-02	35	38
201127	09-009 054-43	39	36	202588	09-009 052-70	55	25	204122	09-009 064-08	35	36
201127	09-009 054-43	71	21	202596E	09-009 611-07	128		204123A	09-009 067-27	35	18
201127	09-009 054-43	128		202596E	09-009 611-07	129		204124	09-009 067-28	35	31
201127	09-009 054-43	129		202597E	09-009 611-08	128		204128A	09-009 601-85	35	26
201127	09-009 054-43	130		202597E	09-009 611-08	129		204129A	09-009 601-84	35	24
201127	09-009 054-43	131		202616	09-009 611-09	128		204139A	09-009 064-17	37	11
201127	09-009 054-43	132		202617	09-009 611-10	128		204140A	09-009 064-18	37	8
201139	09-009 050-16	9	12	202618	09-009 611-11	128		204143B	09-009 601-85	37	24
201152E	09-009 611-00	128		202645	09-009 054-98	41	32	204143A	09-009 601-86	37	25
201155C	09-009 611-01	128		202647A	09-009 065-79	41	29	204145A	09-009 065-70	13	7
201156	09-009 050-20	43	34	202653	09-009 055-00	5	28	204135A	09-009 065-70	15	8
201185	09-009 050-38	43	17	202683	09-009 065-85	41	1	204146	09-009 065-81	39	5
201185	09-009 050-38	43	27	202683	09-009 065-85	62	43	204147	09-009 064-19	39	1
201185	09-009 050-38	49	32	202689	09-009 055-01	5	23	204149	09-009 601-87	39	9
201185	09-009 050-38	55	28	202705A	09-009 055-02	17	42	204152	09-009 065-29	61	41
201191	09-009 050-43	53	11	202706A	09-009 055-03	17	48	204154	09-009 066-28	39	14
201191	09-009 050-43	55	11	202706A	09-009 053-13	41	15	204155	09-009 065-33	61	46
201191	09-009 050-43	61	10	202757A	09-009 053-13	65	46	204156	09-009 064-22	61	47
201211C91	09-009 819-99	61	17	202799	09-009 068-40	128		204158	09-009 064-24	39	27
201224B	09-009 050-55	128		202799	09-009 068-40	129		204159	09-009 064-25	39	28
201224B	09-009 050-55	129		202799	09-009 068-40	131		204160A	09-009 601-89	39	30
201230C	09-009 611-02	128		202849	09-009 055-24	21	13	204161	09-009 053-33	39	19
201230C	09-009 611-02	129		202849	09-009 055-24	23	11	204161	09-009 053-33	71	20
201230C	09-009 611-02	130		202849	09-009 055-24	27	11	204161	09-009 053-33	124	
201230C	09-009 611-02	131		202849	09-009 055-24	31	11	204161	09-009 053-33	125	
201233A	09-009 065-31	61	2	20286A	09-009 069-5A	37	27	204161	09-009 053-33	126	
201252	09-009 050-73	69	7	202875	09-009 601-76	23	29	204161	09-009 053-33	127	
201265E	09-009 050-77	128		202875	09-009 601-76	45	17	204162	09-009 064-26	39	21
201265E	09-009 050-77	129		202875	09-009 601-76	51	25	204172	09-009 064-31	29	27
201265E	09-009 050-77	130		202875	09-009 601-76	73	12	204177B	09-009 067-41	41	8
201265E	09-009 050-77	131		202903	09-009 065-53	47	4	204178	09-009 064-36	41	7
201310A	09-009 051-12	130		202982	09-009 603-51	131		204185	09-009 067-40	47	21
201310A	09-009 051-12	131		202983	09-009 607-47	131		204186A	09-009 833-40	11	18
201323	09-009 051-22	47	3	204003	09-009 065-99	3	16	204187	09-009 064-38	47	8
201360B	09-009 051-43	17	4	204006	09-009 601-82	3	19	204193	09-009 069-36	47	5
201395	09-009 601-61	41	33	204010	14-018 570-01	11	26	204194	09-009 064-40	47	5
201396B	09-009 070-78	130		204014	09-009 064-95	11	25	204198	09-009 602-06	11	8
201396B	09-009 070-78	131		204016	09-009 067-43	11	22	204218	09-009 064-49	9	3
201411B	09-009 068-03	17	5	204018	09-009 055-09	11	16	204223	09-009 064-52	5	31
201473B	09-009 611-03	128		204019A	09-009 055-10	11	15	204242	09-009 064-63	9	14
201485	09-009 065-43	61	8	204020A	09-009 055-11	11	14	204243	09-009 064-64	9	16
201523A	09-009 055-08	11	17	204022	09-009 055-13	11	12	204251	09-009 064-67	3	4
201624	12-610 150-45	9	21	204023	09-009 055-16	11	5	204252B	09-009 065-65	124	
201758	09-009 051-57	47	6	204026	09-009 067-51	11	6	204252B	09-009 065-65	125	
202045	12-500 190-45	25	24	204029	09-009 055-17	13	5	204259	09-009 068-76	49	16
202176	26-536 302-09	17	17	204039	09-009 055-17	15	6	204274	09-009 064-69	25	17
202176	26-536 302-09	25	20	204039B	09-009 069-33	124		204278	09-009 054-29	124	
202176	26-536 302-09	25	26	204039B	09-009 069-33	125		204278	09-009 054-29	125	
202176	26-536 302-09	29	16	204042	09-009 066-85	124		204293	09-009 602-07	27	26
202176	26-536 302-09	49	5	204042	09-009 066-85	125		204293	09-009 602-07	29	13
202176	26-536 302-09	49	25	204042	09-009 066-85	126		204293	09-009 602-07	29	24
202199	09-009 829-30	49	12	204042	09-009 066-85	127		204294B	09-009 065-80	124	
202281	09-009 601-66	73	11	204048A	09-009 055-28	13	16	204294B	09-009 065-80	125	
202286	09-009 051-75	7	9	204048A	09-009 055-28	15	18	204295B	09-009 067-42	124	
202286	09-009 051-75	23	14	204052A	09-009 064-62	23	15	204295B	09-009 067-42	125	
202286	09-009 051-75	33	21	204052A	09-009 064-62	37	18	204314A	09-009 065-25	124	
202286	09-009 051-75	27	14	204055B	09-009 055-33	25	21	204314A	09-009 065-25	125	
202286	09-009 051-75	27	21	204062	09-009 054-19	124		204314A	09-009 065-25	126	
202286	09-009 051-75	53	8	204062	09-009 054-19	125		204314A	09-009 065-25	127	
202286	09-009 051-75	55	8	204062	09-009 054-19	127		204319	09-009 065-97	11	32
202286	09-009 051-75	61	7	204062	09-009 054-19	128		204324	09-009 065-93	31	32
202286	09-009 051-75	63	13	204062	09-009 054-19	129		204343A	09-009 065-59	124	
202286	09-009 051-75	63	19	204062	09-009 054-19	132		204344A	09-009 609-00	124	
202287A	09-009 051-76	47	26	204072	09-009 054-20	124		204345A	09-009 609-01	124	
202295	09-009 066-42	39	35	204072	09-009 054-20	125		204346A	09-009 609-02	124	
202295	09-009 066-42	71	22	204072	09-009 054-20	126		204351	09-009 606-90	39	20
202295	09-009 066-42	128		204072	09-009 054-20	127		204358A	09-009 609-03	124	
202295	09-009 066-42	129		204072	09-009 054-20	128		204358A	09-009 609-03	125	
202295	09-009 066-42	130		204072	09-009 054-20	129		204359A	09-009 609-04	124	

INDEX

PART NO.	PPAFF-NO	PAGE	NO. REF.	PART NO.	PPAFF-NO	PAGE	NO. REF.	PART NO.	PPAFF-NO	PAGE	NO. REF.
204359A	09-009 609-04	125		204521	09-009 065-88	127		204704	09-009 068-98	128	
204360A	09-009 065-40	124		204522	09-009 065-67	124		204705	09-009 067-69	126	
204360A	09-009 065-40	125		204522	09-009 065-67	125		204706	09-009 605-37	17	41
204361A	09-009 609-19	124		204522	09-009 065-67	126		204707	09-009 605-59	17	51
204361A	09-009 609-19	125		204522	09-009 065-67	127		204722	09-009 611-19	129	
204362	09-009 066-90	124		204528	09-009 067-09	126		204724	09-009 068-62	128	
204363	09-009 609-05	124		204529	09-009 067-11	126		204724	09-009 068-62	129	
204364	09-009 609-06	124		204536	09-009 065-87	124		204724	09-009 068-62	130	
204365	09-009 609-07	124		204536	09-009 065-87	125		204724	09-009 068-62	131	
204366	09-009 066-94	124		204536	09-009 065-87	126		204724	09-009 068-62	132	
204366	09-009 066-94	125		204536	09-009 065-87	127		204730	09-009 611-21	128	
204367	09-009 609-08	124		204585	09-009 602-15	63	30	204730	09-009 611-21	130	
204367	09-009 609-08	125		204585	09-009 602-15	65	35	204731	09-009 611-22	129	
204368	09-009 069-23	124		204588	09-009 602-16	35	17	204737	09-009 067-81	11	31
204368	09-009 069-23	125		204592	09-009 069-14	63	26	204742	09-009 068-29	9	10
204369	09-009 609-09	124		204593	09-009 602-17	47	7	204743	09-009 068-31	9	8
204369	09-009 609-09	125		204618	09-009 602-18	35	16	204744	09-009 068-32	9	41
204370	09-009 067-02	124		204623	09-009 067-88	17	36	204745	09-009 068-33	9	35
204370	09-009 067-02	125		204623	09-009 067-88	128		204746	09-009 600-38	9	36
204371	09-009 609-10	124		204623	09-009 067-88	129		204747	09-009 068-34	9	38
204371	09-009 609-10	125		204623	09-009 067-88	132		204748	09-009 068-35	9	38
204372	09-009 609-11	124		204625A	09-009 067-90	17	22	204749	09-009 067-83	9	32
204372	09-009 609-11	125		204627A	09-009 067-92	17	26	204750	09-009 067-94	21	29
204373	09-009 609-12	124		204630	09-009 600-94	21	30	204751	09-009 068-20	35	4
204373	09-009 609-12	125		204631	09-009 067-96	21	32	204752	09-009 068-21	37	19
204374	09-009 066-96	124		204634	09-009 071-55	128		204754A	09-009 814-34	37	13
204374	09-009 066-96	125		204634	09-009 071-55	129		204755	09-009 068-24	37	20
204375	09-009 609-13	124		204634	09-009 071-55	132		204756	09-009 068-26	37	16
204375	09-009 609-13	125		204635	09-009 067-99	128		204757	09-009 068-27	37	15
204376	09-009 609-14	124		204635	09-009 067-99	129		204760A	09-009 603-53	61	15
204376	09-009 609-14	125		204635	09-009 067-99	132		204762	09-009 600-68	21	36
204377	09-009 609-15	124		204636	09-009 068-02	21	38	204781	09-009 069-28	19	35
204377	09-009 609-15	125		204636A	09-009 833-42	21	39	204782	09-009 069-29	19	37
204378	09-009 609-16	124		204638	09-009 068-15	39	12	204783	09-009 069-30	19	31
204378	09-009 609-16	125		204646	09-009 067-87	5	23	204787	09-009 601-24	15	16
204379	09-009 609-35	124		204650A	09-009 602-20	7	1	204788	09-009 602-21	13	17
204379	09-009 609-35	125		204651	09-009 602-41	49	18	204788	09-009 602-21	15	17
204380	09-009 922-04	124		204659	09-009 068-00	130		204788	09-009 602-21	15	19
204380	09-009 922-04	125		204659	09-009 068-00	131		204796	09-009 601-42	39	15
204381	09-009 609-17	124		204659	09-009 068-00	132		204797	09-009 611-23	129	
204381	09-009 609-17	125		204663	09-009 068-07	131		204806	09-009 602-24	47	28
204420	09-009 067-03	125		204664	09-009 068-12	27	23	204810	09-009 067-63	35	40
204420	09-009 067-03	127		204667	09-009 068-19	61	14	204827	09-009 602-25	9	31
204421	09-009 067-07	126		204668	09-009 611-12	128		204830	09-009 603-28	61	44
204421	09-009 067-07	127		204668	09-009 611-12	129		204835	09-009 071-09	61	12
204422	09-009 067-72	125		204668	09-009 611-12	130		204848A	09-009 068-75	5	21
204423	09-009 609-33	126		204668	09-009 611-12	131		204857A-FA	09-009 833-43	9	28
204423	09-009 609-33	127		204670	09-009 067-65	63	1	204862	09-009 602-30	48	29
204431	09-009 065-26	124		204674	09-009 054-50	128		204865A-FA	09-009 602-32	6	23
204431	09-009 065-26	125		204674	09-009 054-50	129		204867	09-009 600-54	9	25
204431	09-009 065-26	126		204674	09-009 054-50	130		204868	09-009 602-42	7	7
204431	09-009 065-26	127		204674	09-009 054-50	131		204870	09-009 602-44	37	28
204431-HC	09-009 833-41	126		204676	09-009 068-43	128		204873	09-009 605-33	11	28
204435	09-009 607-34	49	17	204676	09-009 068-43	129		204874	09-009 605-25	31	12
204439A	09-009 602-09	35	29	204676	09-009 068-43	130		204881	09-009 605-31	11	30
204449	09-009 607-78	61	1	204676	09-009 068-43	131		204882	09-009 069-10	63	31
204451	09-009 602-11	53	6	204676	09-009 068-43	132		204883	09-009 602-46	37	22
204451	09-009 602-11	55	6	204677	09-009 816-54	128		204885	09-009 607-86	65	4
204451	09-009 602-11	61	3	204677	09-009 816-54	129		204886	09-009 602-47	65	6
204451	09-009 602-11	63	20	204677	09-009 816-54	130		204887	09-009 602-48	65	7
204452	09-009 602-12	53	5	204677	09-009 816-54	131		204888	09-009 602-49	59	9
204452	09-009 602-12	55	5	204677	09-009 816-54	132		204888	09-009 602-49	65	9
204452	09-009 602-12	61	5	204679	09-009 611-14	129		204889	09-009 602-50	65	12
204460	09-009 071-51	51	26	204679	09-009 611-14	130		204890	09-009 602-51	65	13
204460	09-009 071-51	127		204681	09-009 600-33	5	24	204891	09-009 602-52	65	15
204466	09-009 607-37	49	20	204681	09-009 609-34	45	15	204892	09-009 602-53	65	17
204495	09-009 602-14	63	17	204683	09-009 609-34	126		204893	09-009 602-54	65	18
204499	09-009 608-00	73	2	204683	09-009 611-15	128		204894	09-009 603-14	66	19
204500	09-009 608-01	73	2	204690	09-009 611-15	129		204895	09-009 603-15	65	20
204501	09-009 608-02	73	2	204690	09-009 611-15	130		204896	09-009 070-16	61	13
204502	09-009 608-03	73	3	204691	09-009 611-16	129		204897	09-009 607-85	65	1
204502A	09-009 813-26	51	22	204691	09-009 611-16	130		204898	09-009 603-34	65	2
204502A	09-009 813-26	127		204693	09-009 068-39	129		204900	09-009 833-44	63	41
204503	09-009 608-04	73	3	204693	09-009 068-39	131		204901	09-009 070-79	27	30
204503	09-009 608-05	73	3	204700	09-009 609-31	126		204902	09-009 603-16	23	27
204503	09-009 608-06	73	4	204701	09-009 609-32	126		204903	09-009 068-11	25	10
204506	09-009 608-07	73	4	204702	09-009 067-70	124		204905	09-009 603-17	25	7
204507	09-009 608-08	73	4	204702	09-009 067-70	125		204906	09-009 603-50	73	10
204508	09-009 608-09	73	5	204702	09-009 067-70	126		204907	09-009 068-97	128	
204509	09-009 608-10	73	5	204702	09-009 067-70	127		204910	09-009 611-25	130	
204510	09-009 608-11	73	5	204702	09-009 067-70	128		204911	09-009 611-26	130	
204511	09-009 608-12	73	6	204702	09-009 067-70	129		204913	09-009 611-27	128	
204512	09-009 608-13	73	6	204702	09-009 067-70	131		204921	09-009 603-18	49	4
204513	09-009 608-14	73	6	204702	09-009 067-70	132		204921	09-009 603-18	49	24
204514	09-009 608-15	73	7	204703	09-009 067-68	126		204929	09-009 603-12	41	4
204515	09-009 608-16	73	7	204703	09-009 067-68	129		204930	09-009 603-23	41	3
204516	09-009 608-17	73	7	204704	09-009 068-98	124		204935	09-009 609-20	125	
204521	09-009 065-88	124		204704	09-009 068-98	125		204935	09-009 609-20	126	
204521	09-009 065-88	125		204704	09-009 068-98	126		204936	09-009 609-21	125	
204521	09-009 065-88	126		204704	09-009 068-98	127		204936	09-009 609-21	126	

INDEX

PART NO.	PAFF-NO	PAGE	NO. REF.	PART NO.	PAFF-NO	PAGE	NO. REF.	PART NO.	PAFF-NO	PAGE	NO. REF.
204937	09-009 609-22	125		205322	09-009 066-02	129		208069	09-009 800-72	124	
204937	09-009 609-22	126		205323	09-009 611-38	128		208070	09-009 066-98	125	
204938	09-009 609-23	125		205323	09-009 611-38	129		208074	09-009 071-24	125	
204938	09-009 609-23	126		205324	09-009 611-39	128		208074	09-009 071-24	127	
204939	09-009 609-24	126		205324	09-009 611-39	129		208075	09-009 071-25	126	
204939	09-009 609-24	126		205324	09-009 611-39	132		208075	09-009 071-25	127	
204939	09-009 609-24	127		205325	09-009 611-40	128		208076	09-009 067-73	125	
204940	09-009 609-25	125		205325	09-009 611-40	129		208077	09-009 071-26	126	
204940	09-009 609-25	126		205325	09-009 611-40	132		208077	09-009 071-26	127	
204940	09-009 609-25	127		205326	09-009 611-41	128		208078	09-009 806-04	128	
204941	09-009 609-26	125		205326	09-009 611-41	129		208078	09-009 806-04	129	
204941	09-009 609-26	126		205326	09-009 611-41	132		208078	09-009 806-04	130	
204941	09-009 609-26	127		205327	09-009 611-42	128		208078	09-009 806-04	131	
204942	09-009 609-27	125		205327	09-009 611-42	129		208079	09-009 828-88	129	
204942	09-009 609-27	126		205456A91	09-009 823-15	61	21	208079	09-009 828-88	131	
204943	09-009 609-28	125		205457A91	09-009 826-67	61	18	208079	09-009 828-88	132	
204943	09-009 609-28	126		205465	09-009 833-47	128		208080	09-009 833-52	129	
204943	09-009 609-28	127		205466	09-009 603-75	67	9	208080	09-009 833-52	130	
204944	09-009 609-29	125		205467	09-009 603-76	67	3	208083	09-009 822-02	129	
204944	09-009 609-29	126		205468-JA	09-009 603-77	67	14	208083	09-009 822-02	131	
204944	09-009 609-29	127		205469-JA	09-009 603-78	67	15	208085	09-009 829-37	129	
204945	09-009 066-99	125		205470-JA	09-009 815-05	67	11	208086	09-009 068-61	129	
204945	09-009 066-99	126		205473	09-009 823-67	67	10	208086	09-009 068-61	130	
204945	09-009 066-99	127		205495-2	09-009 603-81	17	2	208086	09-009 068-61	131	
204946	09-009 609-30	125		205495-2	09-009 603-81	33	5	208087	09-009 806-98	128	
204946	09-009 609-30	126		205525	09-009 620-30	128		208087	09-009 806-98	130	
204946	09-009 609-30	127		205678A91	09-009 823-16	61	19	208087	09-009 806-98	131	
204949	09-009 833-45	130		205679A91	09-009 823-17	61	20	208087	09-009 806-98	132	
204960	09-009 608-24	65	40	205685	09-009 732-75	5	37	208090	09-009 611-20	128	
204961	09-009 608-26	65	45	205764	09-009 612-87	67	5	208090	09-009 611-20	130	
204962	09-009 608-25	65	41	205765	09-009 612-88	67	6	208091	09-009 833-53	131	
204963	09-009 611-28	126		205835	09-009 800-07	61	24	208092	09-009 833-54	131	
204963	09-009 611-28	130		205857	09-400 106-00	35	28	208093	09-009 833-55	130	
204964	09-009 611-29	130		206181B	09-009 833-48	39	6	208093	09-009 833-55	131	
204964	09-009 611-29	132		206225	09-009 618-60	59	18	208095	09-009 068-38	131	
204966	09-009 603-35	65	3	206336	09-009 604-60	67	1	208096	09-009 601-95	39	31
204990	09-009 603-48	73	8	206337	09-009 612-93	67	2	208108	09-009 604-68	35	41
204990	09-009 603-48	130		206337	09-009 612-93	67	4	208109	09-009 604-69	35	46
204990	09-009 603-48	131		206457	09-009 604-61	5	5	208168	09-009 604-71	35	45
204991	09-009 603-49	73	9	206682	09-009 800-09	5	6	208169A	09-009 071-15	3	9
204991	09-009 603-49	130		206781	09-009 820-18	33	22	208173	09-009 604-72	25	6
204991	09-009 603-49	131		206781	09-009 820-18	49	30	208192	09-009 605-97	13	11
205015-2	09-009 612-74	31	22	207358	09-400 144-00	11	21	208194	09-009 606-08	29	14
205018	09-009 833-46	65	47	208001-FD	09-009 070-83	7	16	208195	09-009 606-09	29	15
205064	09-009 067-66	63	2	208003	09-009 070-85	7	28	208196	09-009 606-11	29	10
205065	09-009 603-38	63	4	208004	09-009 833-49	7	29	208215	09-009 071-27	124	
205066	09-009 603-39	63	5	208005	09-009 600-44	7	30	208215	09-009 071-27	126	
205067	09-009 603-40	63	7	208006	09-009 833-50	7	31	208215	09-009 071-27	127	
205068	09-009 069-68	63	8	208008-FD	09-009 604-64	7	19	208216	09-009 071-28	124	
205069	09-009 603-41	63	10	208009	09-009 070-87	7	21	208217	09-009 071-29	125	
205070	09-009 069-15	63	14	208010	09-009 070-88	7	24	208217	09-009 071-29	126	
205072	09-009 069-24	63	22	208023AHD	09-009 604-65	5	26	208218	09-009 071-30	124	
205088	09-009 604-86	31	36	208025	09-009 606-13	29	1	208219	09-009 071-31	124	
205091	09-009 067-64	59	38	208026	09-009 606-15	29	4	208219	09-009 071-31	126	
205091	09-009 067-64	63	38	208027	09-009 606-16	29	3	208219	09-009 071-31	127	
205091	09-009 067-64	65	48	208028	09-009 606-17	29	6	208220	09-009 071-32	125	
205103	09-009 603-42	63	33	208029	09-009 606-18	29	7	208221	09-009 800-73	125	
205104	09-009 069-13	63	28	208030	09-009 611-71	130		208222	09-009 800-74	124	
205135	09-009 068-60	128		208030	09-009 611-71	131		208223	09-009 071-33	125	
205135	09-009 068-60	129		208031	09-009 611-43	130		208224	09-009 800-75	124	
205136	09-009 068-74	128		208031	09-009 611-43	131		208224	09-009 800-75	126	
205136	09-009 068-74	129		208032	09-009 611-44	131		208225	09-009 071-34	125	
205136	09-009 068-74	130		208033	09-009 071-57	131		208225	09-009 071-34	126	
205136	09-009 068-74	131		208034	09-009 611-45	131		208235	09-009 606-51	39	8
205137	09-009 069-11	63	32	208035	09-009 611-46	131	1	208245	09-009 612-96	9	42
205216A	09-009 607-76	5	11	208036	09-009 611-47	131	1	208247	09-009 605-45	17	11
205217	09-009 603-45	5	13	208037	09-009 611-48	131	1	208248	09-009 605-46	17	9
205235	09-009 071-18	129		208038	09-009 608-81	131	4	208249	09-009 605-47	17	1
205236	09-009 071-07	129		208041	09-009 611-52	131	1	208250	09-009 605-48	17	10
205237	09-009 068-10	129		208044	09-009 611-53	130		208258-2	09-009 605-49	25	25
205238	09-009 067-67	129		208044	09-009 611-53	131		208260	09-009 605-50	47	23
205243	09-009 611-32	130		208049	09-009 611-56	131		208272	09-009 069-89	11	10
205243	09-009 611-32	131		208050	09-009 611-57	131		208273	09-009 605-51	37	1
205243	09-009 611-32	132		208051	09-009 606-41	130		208274	09-009 605-52	37	2
205244	09-009 068-42	130		208051	09-009 606-41	131		208275	09-009 605-53	37	3
205244	09-009 068-42	131		208053	09-009 611-60	131		208276	09-009 605-54	37	4
205252	09-009 071-08	129		208056	09-009 833-51	7	33	208284	09-009 605-56	35	5
205253	09-009 065-74	129		208058	09-009 600-45	7	32	208285	09-009 607-01	35	7
205253	09-009 065-74	130		208062	09-009 069-52	124		208286	09-009 607-02	31	20
205253	09-009 065-74	131		208063	09-009 071-39	124		208286	09-009 607-02	35	8
205255	09-009 611-34	130		208063	09-009 071-19	126		208292	09-009 605-76	23	16
205255	09-009 611-34	131		208063	09-009 071-19	127		208299-HD	09-009 833-56	5	1
205256	09-009 611-35	130		208064	09-009 071-20	125		208307	09-009 607-09	19	13
205257	09-009 611-72	130		208064	09-009 071-20	126		208307	09-009 607-09	21	14
205319	09-009 603-47	61	36	208065	09-009 071-21	124		208308	09-009 607-10	49	1
205320	09-009 611-36	128		208066	09-009 071-22	124		208313	09-009 607-11	41	11
205320	09-009 611-36	129		208066	09-009 071-22	126		208314	09-009 607-12	41	13
205321	09-009 611-37	128		208066	09-009 071-22	127		208315	09-009 607-13	41	14
205321	09-009 611-37	129		208067	09-009 071-23	125		208316	09-009 607-14	41	5
205322	09-009 066-02	128		208068	09-009 800-71	125		208318	09-009 607-16	47	24