

PARTS LIST

R SERIES

Industrial Sewing Machines

R 9202A R 9202A/UTC
R 9202C R 9202C/UTC
R 9202F
R 9203A R 9203A/UTC
R 9203C R 9203C/UTC
R 9203F
R 9302A R 9302A/UTC
R 9302C R 9302C/UTC
R 9302F
R 9303A R 9303A/UTC
R 9303C R 9303C/UTC
R 9303F

Industrial Sewing Machines

Kansai Special

Contents

1. Housing components (カバー関係)	1
2. Bushings (ブッシュ関係)	3
3-1. Thread eyelet components (糸道機構)	5
3-2. Thread eyelet components (糸道機構)	7
4. Oil lubrication apparatus (給油機構).....	9
5. Needle lever crank (クランク機構).....	11
6. Feed rocker (送り機構).....	13
7. Loper (ルーパー機構)	15
8. Arm shaft mechanism (上軸機構).....	17
9. Spreader components (上飾り機構).....	18
10. Foot lifter mechanism (押え揚げ機構).....	19
11. Wiper (ワイパー機構)	21
12. Thread under trimming knife (上飾り系糸切り機構)	23
13. Under trimming knife (自動糸切りメス装置)	25
14. Air control diagram foot lifter (押え揚げエアー機構)	27
15. Gauge parts (ゲージ関係).....	29
16. Attachments (アタッチメント)	33
17. Thread stands accessories (糸立て・アクセサリー).....	35
18. Table diagram (テーブル図)	37
19. Index (索引)	38

1. Housing components (カバー関係)

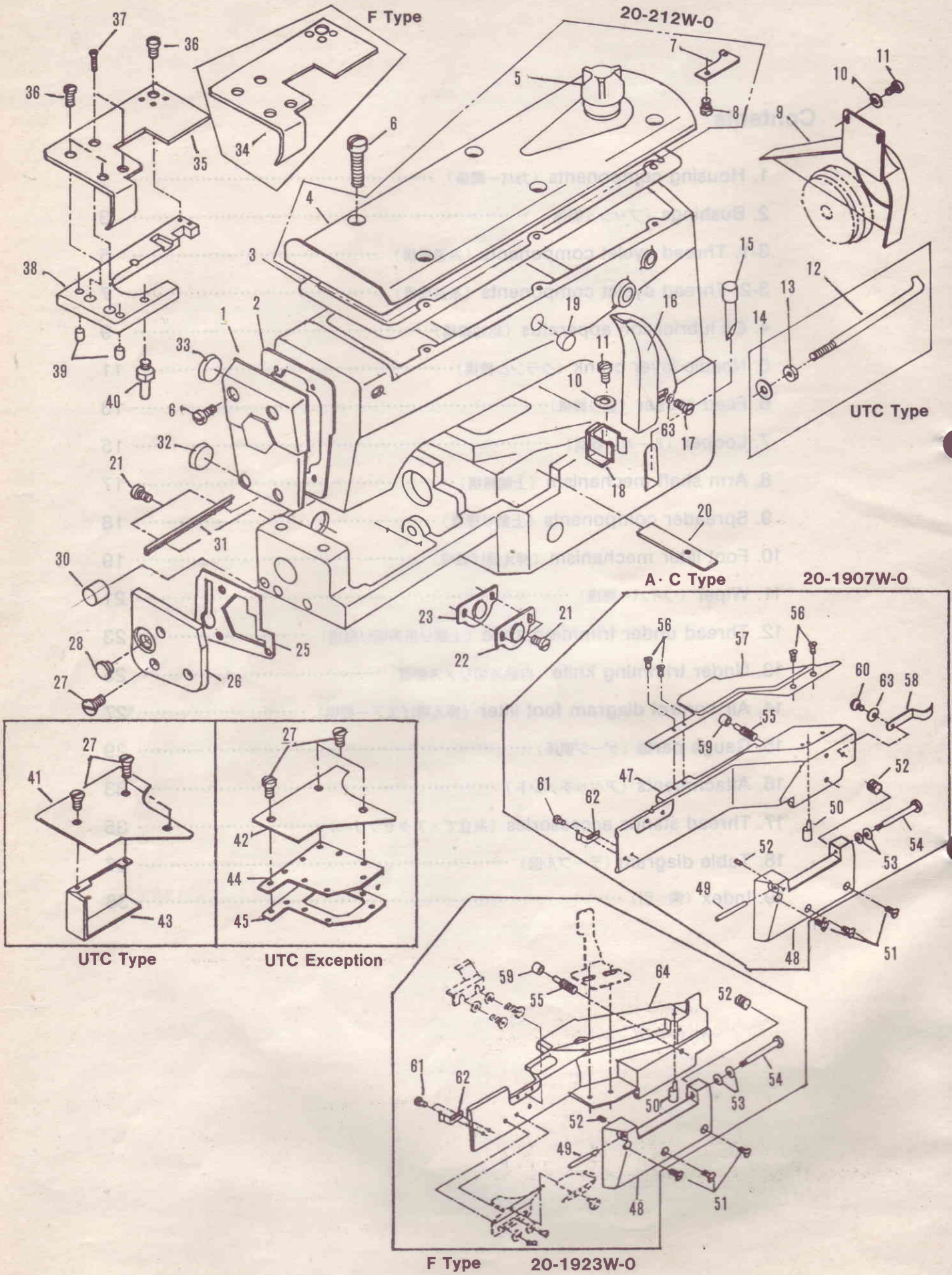

No.	Part No.	Part Name	品 名	Q, ty
1	21-805W-0	Front head cover	面板 (UTC除外)	1
2	23-2390-0	Front head cover gasket	面板パッキン	1
3	23-8030-0	Top head cover gasket	立ロットカバーパッキン	1
4	21-212W-0	Top head cover	立ロットカバー	1
5	39-2330-0	Oil pot	オイルポット	1
6	84-5660-0	Screw	ネジ	10
7	39-1370-0	Pipe support	パイプサポート	1
8	84-1610-0	Screw	ネジ	1
9	21-4020-0	Pulley cover	プーリーカバー	1
10	75-4550-0	Washer	ワッシャ	3
11	84-5710-0	Screw	ネジ	3
12	06-9570-0	Needle positioner mount bar	ポジションナーバー (UTCタイプ)	1
13	88-1660-0	Nut	ナット	1
14	75-4520-0	Washer	ワッシャ	1
15	39-2160-0	Oil gauge	オイルゲージ	1
16	21-938G-0	Cover	下糸道カバー	1
17	84-5680-0	Screw	ネジ	1
18	21-9330-0	Ruler base stopper	定規台止め金具	1
19	23-1750-0	Rubber plug	蓋ゴム	1
20	23-9070-0	Felt	ベッド用フェルト	1
21	84-3700-0	Screw	ネジ	4
22	21-9540-0	Seal cover	ルーパー台カバー	1
23	23-9140-0	Seal cover gasket	ルーパー台カバーパッキン	1
25	23-9090-0	Side cover gasket	横カバーパッキン	1
26	21-936W-0	Side cover	横カバー	1
27	84-5660-0	Screw	ネジ	5
28	23-4270-0	Top head access plug	油止め蓋	1
30	23-1680-0	Rubber plug	油止めゴム	1
31	21-949G-0	Rear cover	シリンダー補助カバー	1
32	23-9080-0	Rubber plug	送り土台シールキャップ	1
33	23-1530-0	Rubber plug	振元シール (前)	1
34	21-948W-0	Needle plate support cover (F)	針板土台化粧カバー (Fタイプ)	1
35	21-947W-0	Needle plate support cover (A,C)	針板土台化粧カバー (A,Cタイプ)	1
36	84-7630-0	Screw	ネジ	3
37	84-3620-0	Screw	ネジ	3
38	14-9100-2	Needle plate support	針板土台	1
39	71-2520-0	Nock pin	針板用ノックピン	2
40	84-6340-0	Screw	ネジ	1
41	21-900W-0	Upper base cover (UTC)	上スペースカバー (UTC)	1
42	21-950W-0	Upper base cover (whthout UTC)	上ベースカバー (UTC除外)	1
43	21-914W-0	Knife action cover	メス駆動部化粧カバー	1
44	21-9220-0	Oil reservoir top	上油カバー	1
45	23-9220-0	Gasket for top	上油カバーパッキン	1
47	21-942W-0	Front cover (A,C)	定規台 (A,Cタイプ)	1
48	21-906W-0	Front cover hinge	前カバーヒンジ	1
49	25-9040-0	Hinge pin	ヒンジピン	1
50	71-1160-0	Ruler table set pin	定規台止めピン	1
51	84-5660-0	Screw	ネジ	3
52	84-3140-0	Screw	ネジ	2
53	79-9220-0	Cover plate spring	カバー用皿バネ	2
54	25-9030-0	cover hinge screw	カーヒンジネジ	1
55	85-2090-0	Screw	ネジ	1
56	84-6610-0	Screw	ネジ	4
57	21-907W-0	Ruler plate	定規板	1
58	25-9050-0	Knob	前カバー取手	1
59	23-9040-0	Front cover cushion	前カバークッション	1
60	84-5750-0	Screw	ネジ	1
61	84-3790-0	Screw	ネジ	2
62	79-9230-0	Side cover plate spring	前カバー板バネ	1
63	75-4550-0	Washer	ワッシャ	2
64	21-946W-0	Front cover (F)	定規台 (F用)	1

2. Bushings (ブッシュ関係)

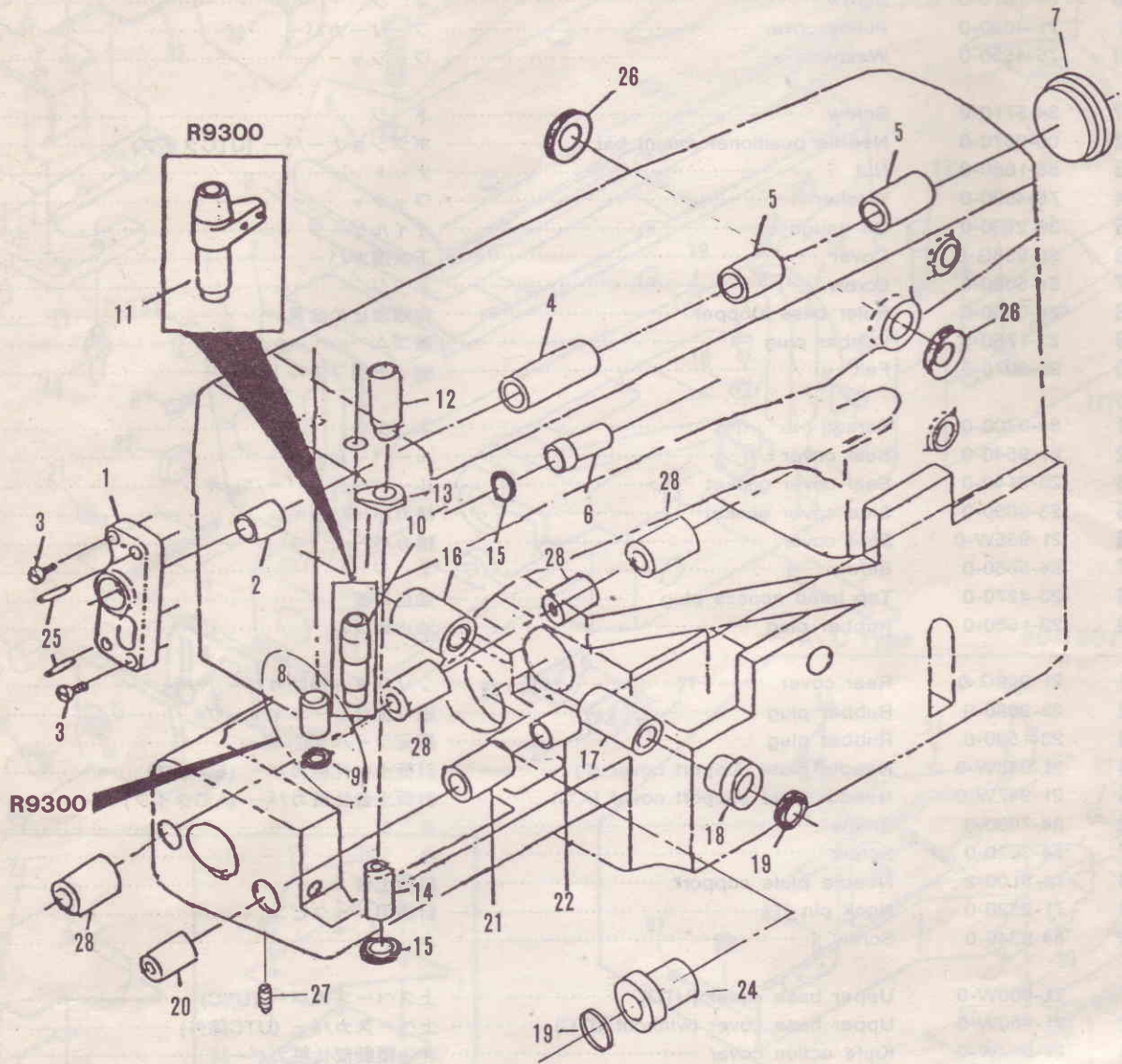

No.	Part No.	Part Name	品 名	9200	9300
1	69-8030-0	Bushing support	ブッシュサポート	1	1
2	81-8030-0	Bushing	上シャフトヘッドブッシュ	1	1
3	84-7630-0	Screw	ネ ジ	2	2
4	81-0810-0	Bushing	上シャフトブッシュG	1	1
5	81-0820-0	Bushing	上シャフトブッシュH	2	2
6	81-8080-0	Arm crank bushing	アームクランクブッシュ	1	1
7	23-8000-0	Upper shaft cover	上シャフト蓋	1	1
8	81-1490-0	Top cover shaft bushing (R9300)	上飾りブッシュ (R9300)		1
9	94-8010-0	Oil seal	オイルシール		1
10	81-1630-0	Presser bar bushing (R9200)	押棒ブッシュ (R9200)	1	
11	81-1620-0	Presser bar bushing (R9300)	押棒ブッシュ (R9300)		1
12	81-2060-0	Needle bar bushing (upper)	針棒ブッシュ (上)	1	1
13	39-8010-0	Oil fense	オイルフェンス	1	1
14	81-2090-0	Needle bar bushing (lower)	針棒ブッシュ (下)	1	1
15	94-2310-0	Oil seal	オイルシール	2	2
16	81-2370-0	Looper drive lever shaft bushing	振り元ブッシュ (後)	1	1
17	81-2360-0	Looper drive lever shaft bushing	振り元ブッシュ (中)	1	1
18	81-9030-0	Looper drive lever shaft bushing	振り元ブッシュ (前)	1	1
19	94-2140-0	Oil seal	オイルシール	2	2
20	81-9040-0	Bushing	針受けブッシュ	1	1
21	81-7530-0	Feed rocker shaft bushing	送り土台シャフトブッシュ	1	1
22	81-7520-0	Bushing	送り台シャフトブッシュC	1	1
24	81-9090-0	Bushing	下シャフトブッシュ	1	1
25	71-2160-0	Knock pin	ノックピン	2	2
26	94-8020-0	Oil seal	オイルシール	2	2
27	84-5210-0	Screw	ネ ジ	1	1
28	81-7540-0	Bushing	送り元台シャフトブッシュ	4	4

3-1. Thread eyelet components (糸道機構)

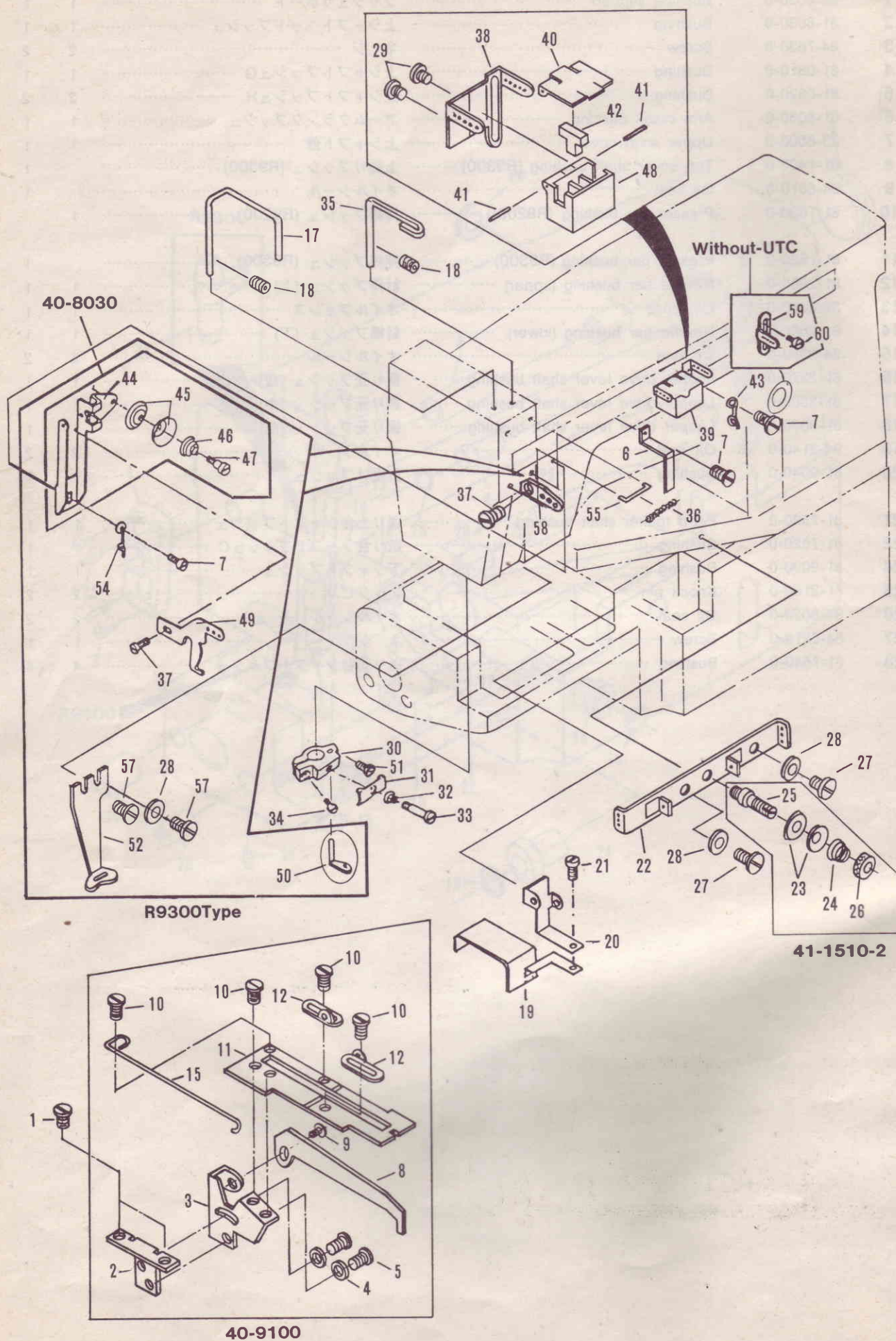

No.	Part No.	Part Name	品 名	9200	9300
1	84-5660-0	Screw	ネ ジ	2	2
2	43-9220-0	Cast-off support bracket	下糸捌き取付台	1	1
3	43-9240-0	Cast-off support bracket	下糸捌き取付台	1	1
4	75-4520-0	Washer	ワッシャ	2	2
5	84-5710-0	Screw	ネ ジ	2	2
6	21-7120-0	Needle lever eyelet safety plate	糸道安全カバー	1	1
7	84-5710-0	Screw	ネ ジ	3	3
8	43-9260-0	Looper thread retainer	下糸捌き上	1	1
9	84-3740-0	Screw	ネ ジ	1	1
10	84-1630-0	Screw	ネ ジ	5	5
11	43-9200-0	Cast-off support plate	下糸捌き板	1	1
12	43-9040-0	Cast-off support plate eyelet (right)	捌き糸道 (右)	2	2
15	43-3380-0	Looper thread retainer wire D	下糸捌きピンD	1	1
17	21-7030-0	Needle bar eyelet safety cover	針棒糸道カバー	1	1
18	84-5210-0	Screw	ネ ジ	2	2
19	21-9450-0	Cover	エキセンカバー	1	1
20	43-9250-0	Looper thread eyelet	ルーバー案内糸道	1	1
21	84-5640-0	Screw	ネ ジ	1	1
22	43-9170-0	Looper guide eyelet	下糸捌きガイド糸道	1	1
23	41-1550-0	Small tension plate	チャンポン皿	2	2
24	41-1530-0	Spring	バネ	1	1
25	41-1510-0	Tension post	調子芯棒	1	1
26	41-1540-0	Nut	上糸チャンポン用調節ナット	1	1
27	84-5640-0	Screw	ネ ジ	2	2
28	75-4550-0	Washer	ワッシャ	2	3
29	84-1610-0	Screw	ネ ジ	2	2
30	41-3040-1	Nipper bracket	針棒クランプ	1	1
31	45-1420-0	Tension nipper	テンションニッパー	1	1
32	41-7220-0	Spring	スプリング	1	1
33	84-1710-0	Screw	ネ ジ	1	1
34	84-4130-0	Screw	ネ ジ	1	1
35	45-2510-0	Needle thread take-up wire	上糸受け	1	1
36	79-2280-0	Spring	スプリング	1	1
37	84-5740-0	Screw	ネ ジ	1	1
38	45-1690-0	Silicone tank thread eyelet	シリコンタンク糸道	1	1
39	20-532G-0	Silicone tank-set	シリコンタンクセット	1	1
40	27-5330-0	Silicone tank-lid	シリコンタンクフタ	1	1
41	71-2020-0	Pin	ピン	2	2
42	27-5340-0	Felt	フェルト	1	1
43	47-1440-0	Top cover thread eyelet	糸道		1
44	45-0940-0	Covering looper thread eyelet	上飾り糸糸道		1
45	41-1560-0	Small tension disc	上飾り捌き小チャンポン皿		2
46	41-1570-0	Spring	上飾り捌き調子バネ		1
47	84-1710-0	Screw	ネ ジ		1
48	27-5310-0	Silicone tank	シリコンタンク	1	1
49	45-0960-0	Needle lever thread eyelet	上糸てんびん糸道		1
50	45-9140-0	"L" thread eyelet	L型糸道		1
51	84-1120-0	Screw	ネ ジ		1
52	45-9250-0	Zigzag thread eyelet	への字糸道		1
54	47-1490-0	Thread eyelet	糸道		1
55	45-2460-0	Guide bar	上糸ガイドバー	1	1
57	84-3610-0	Screw	ネ ジ		2
58	45-0910-0	Needle lever thread eyelet (R9200)	上糸てんびん糸道	1	
59	45-0810-0	Upper thread eyelet W3(without UTC)	上糸糸道W3 (UTC除外)	1	1
60	84-5710-0	Screw	ネ ジ	1	1

3-2. Thread eyelet components (糸道機構)

UTC Exception

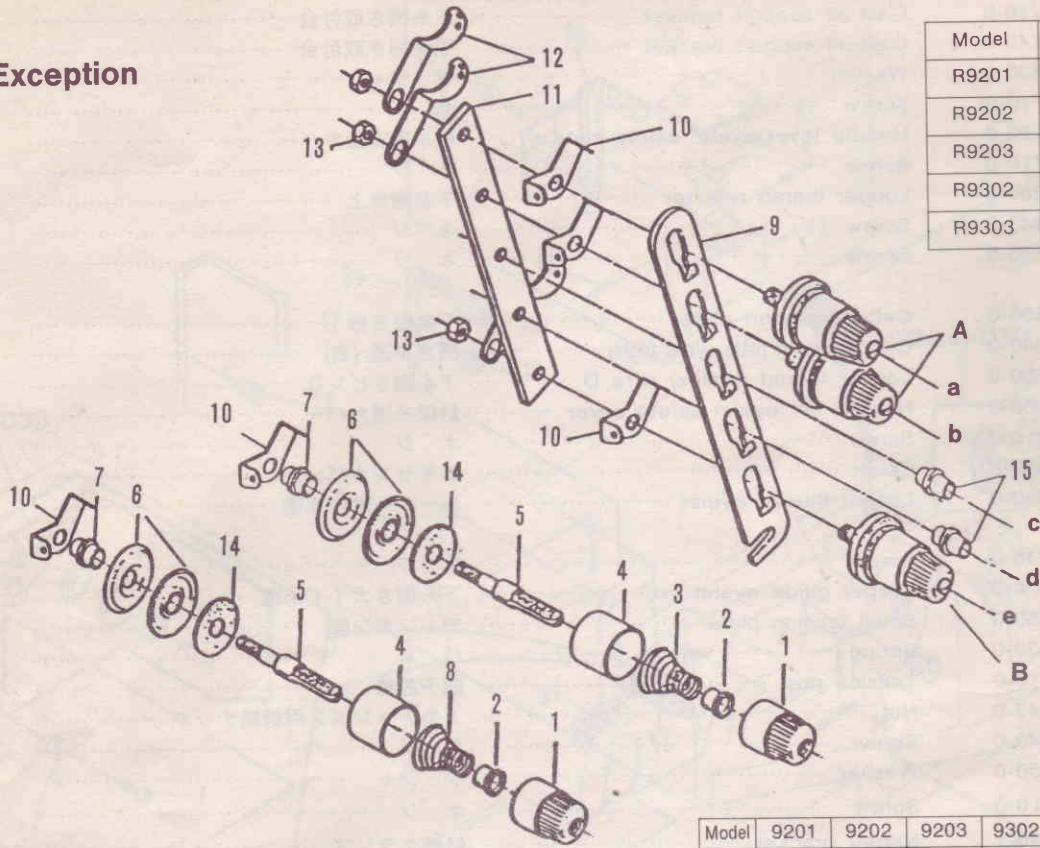

Model	Set No.
R9201	40-811B-0
R9202	40-821B-0
R9203	40-831B-0
R9302	40-822B-0
R9303	40-832B-0

UTC Type

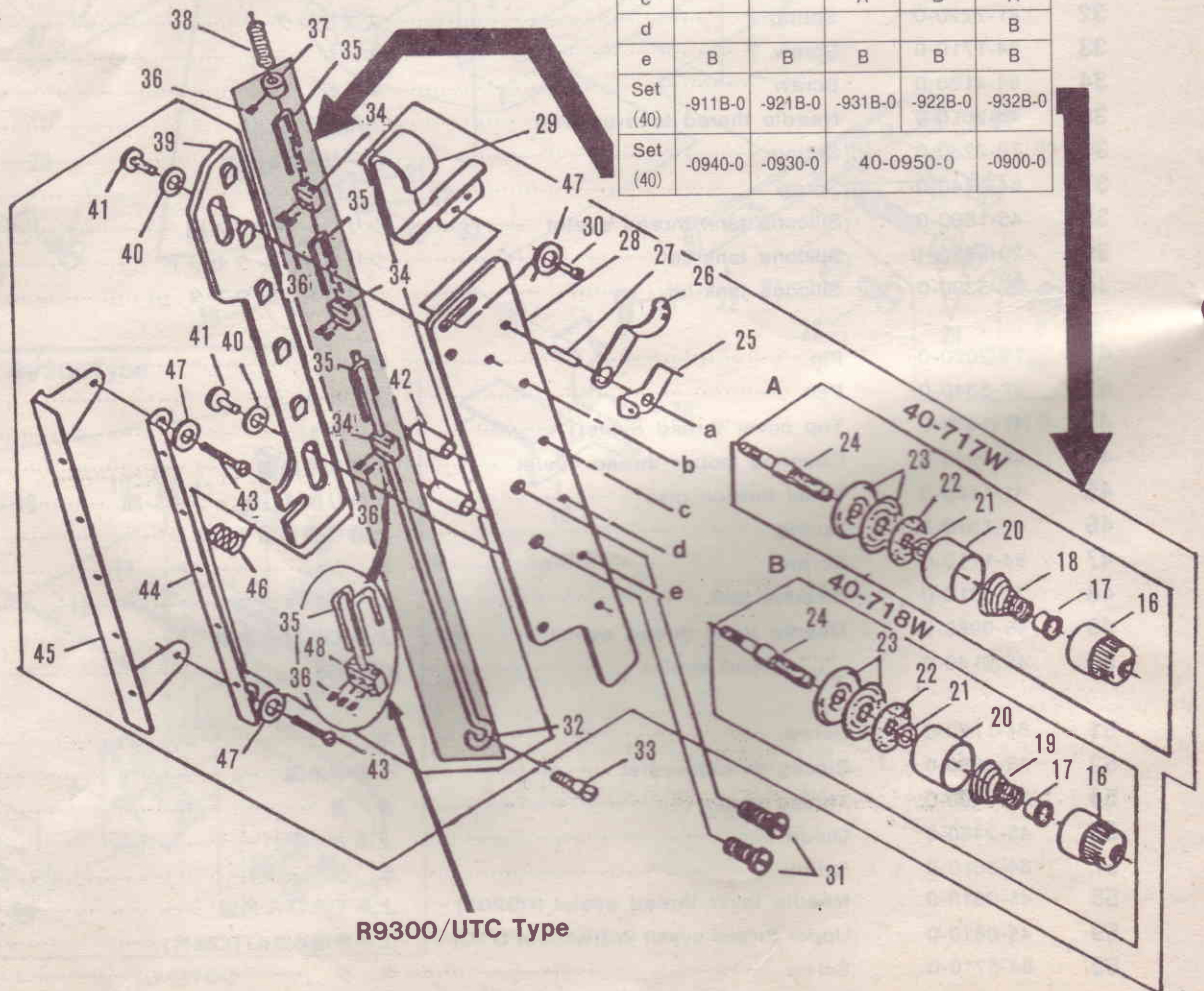

Model	9201	9202	9203	9302	9303
a	A	A	A	A	A
b		A	A	A	A
c			A	B	A
d					B
e	B	B	B	B	B
Set (40)	-911B-0	-921B-0	-931B-0	-922B-0	-932B-0
Set (40)	-0940-0	-0930-0	40-0950-0		-0900-0

R9300/UTC Type

No.	Part No.	Part Name	品 名	9201	9202	9203	9302	9303
1	41-101W-0	Tension regulation nut	チャンポン皿 小ケース	2	3	4	4	5
2	41-105W-0	Tension disc ratchet	チャンポン皿ラチェット	2	3	4	4	5
3	41-7010-0	Needle thread tension spring (strong)	チャンポン調子バネ (強)	1	2	3	2	3
4	41-107W-0	Tension disc cover	チャンポン皿 大ケース	2	3	4	4	5
5	41-1720-0	Tension post	調子棒	2	3	4	4	5
6	41-1110-0	Tension disc cover	チャンポン皿	4	6	8	8	10
7	41-1310-0	Tension post cover	調子棒カラー	2	3	4	4	5
8	41-7020-0	Needle thread tension spring (weak)	チャンポン調子バネ (弱)	1	1	1	2	2
9	41-236B-0	Tension regulating plate	チャンポン皿調節板	1	1	1	1	1
10	41-1150-0	Tension post thread eyelet	糸道 上	2	3	4	5	6
11	41-237B-0	Tension post holder	チャンポン元板	1	1	1	1	1
12	41-1170-0	Tension post thread eyelet	糸道 下	2	3	4	5	6
13	86-4110-0	Nut	ナット	1	2	3	3	4
14	23-3240-0	Felt	取付フェルト	2	3	4	4	5
15	41-1320-0	Tension post collar	調子棒カラー	2	2	1	1	1
16	41-101W-0	Tension regulation nut	チャンポン皿 小ケース	2	3	4	4	5
17	41-105W-0	Tension disc ratchet	チャンポン皿ラチェット	2	3	4	4	5
18	41-7010-0	Needle thread tension spring (strong)	チャンポン調子バネ (強)	1	2	3	2	3
19	41-7020-0	Needle thread tension spring (weak)	チャンポン調子バネ (弱)	1	1	1	2	2
20	41-107W-0	Tension disc cover	チャンポン皿 大ケース	2	3	4	4	5
21	33-8020-0	Tension disc washer	チャンポン座金	2	3	4	4	5
22	23-3240-0	Felt	取付フェルト	2	3	4	4	5
23	41-1110-0	Tension disc cover	チャンポン皿	4	6	8	8	10
24	41-1750-0	Tension post	上糸調子棒	2	3	4	4	5
25	41-1150-0	Tension post thread eyelet	糸道 上	2	3	4	5	6
26	41-1170-0	Tension post thread eyelet	糸道 下	2	3	4	5	6
27	06-9440-0	Thread release pin	上糸緩めピン	2	3	4	4	5
28	41-729B-0	Tension post holder	チャンポン元台	1	1	1	1	1
29	06-948B-0	Thread release post guide	糸緩め棒ガイド (上)	1	1	1	1	1
30	84-3610-0	Screw	ネ ジ	2	2	2	2	2
31	84-7650-0	Screw	ネ ジ	2	2	2	2	2
32	41-7260-0	Thread release post	糸緩め棒	1	1	1	1	1
33	84-7820-0	Screw	ネ ジ	1	1	1	1	1
34	06-0670-0	Hook holder	糸緩めスライド	1	3	5	5	5
35	06-0710-0	Hook	糸緩め用フック	3	3	5	5	5
36	84-3140-0	Screw	ネ ジ	6	7	11	11	11
37	75-9410-0	Thread release cushion collar	糸緩めクッションカラー	1	1	1	1	1
38	79-9140-0	Thread release cushion spring	糸緩めクッションバネ	1	1	1	1	1
39	41-7300-0	Tension regulating plate	チャンポン調節板	1	1	1	1	1
40	75-9420-0	Tension post collar	チャンポンカラー	2	2	2	2	2
41	84-5590-0	Screw	ネ ジ	2	2	2	2	2
42	75-9430-0	Tension post collar	チャンポンカラー	2	2	2	2	2
43	84-3740-0	Screw	ネ ジ	2	2	2	2	2
44	41-7280-0	Thread release guide threadeyelet (right)	糸緩め案内糸道 (右)	1	1	1	1	1
45	41-7270-0	Thread release guide threadeyelet (left)	糸緩め案内糸道 (左)	1	1	1	1	1
46	79-1640-0	Stop holder spring (weak)	ストップ台用巻バネ (弱)	1	1	1	1	1
47	75-4550-0	Washer	ワッシャ	4	4	4	4	4
48	06-0170-0	Tension release slide	糸緩めスライド	1				

4. Oil lubrication apparatus (給油機構)

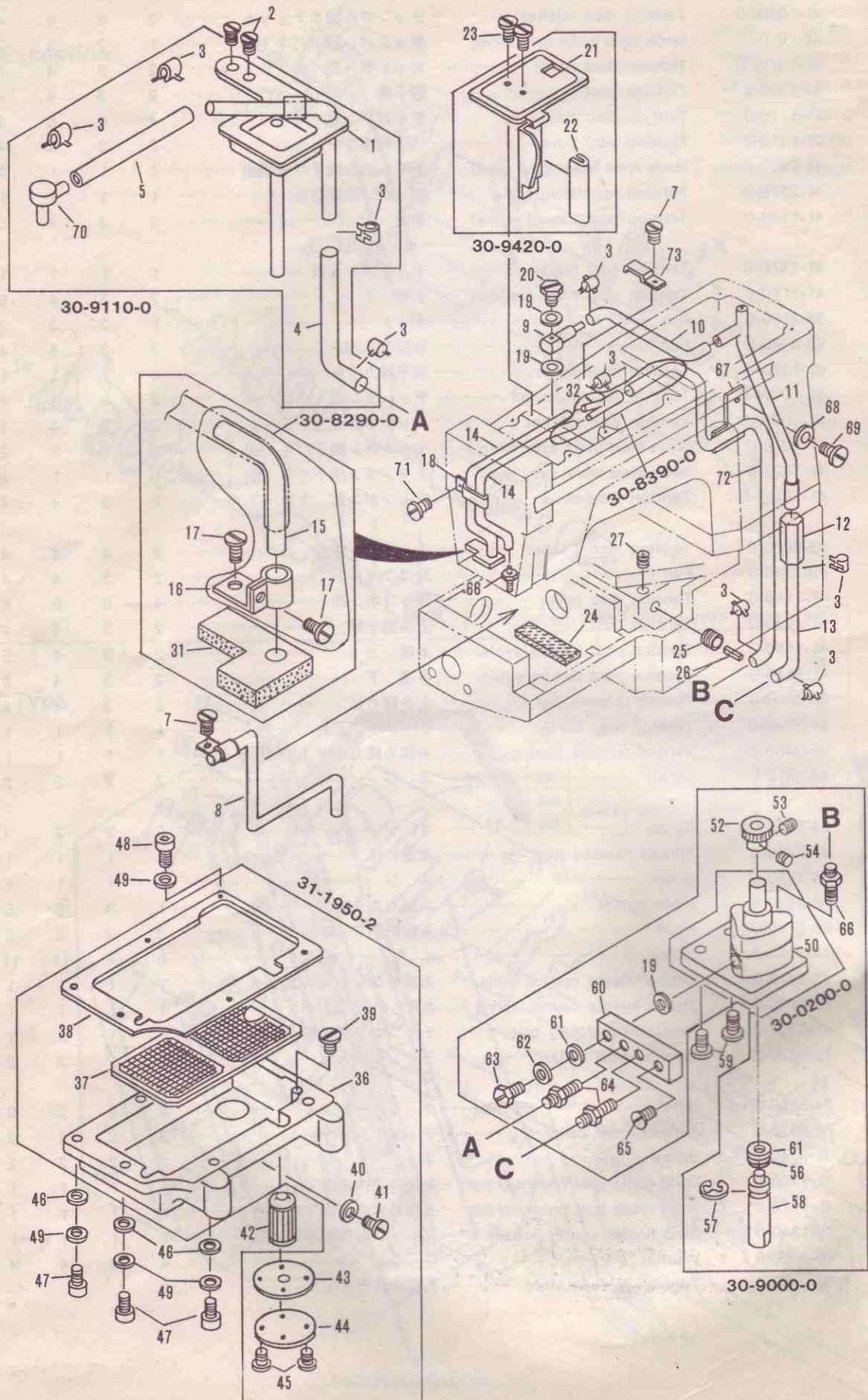

No.	Part No.	Part Name	品 名	Q, ty
1	35-9110-0	Oil distributor set	分配配管セット	1
2	84-5710-0	Screw	ネジ	2
3	35-4120-0	Tube clip	配管用ホースバインド(小)	9
4	35-3420-0	Vinyl tube (215L)	ビニールチューブ215L	1
5	35-2070-0	Vinyl tube (50L)	ビニールチューブ50L	1
7	84-5740-0	Screw	ネジ	2
8	35-9070-0	Feeder support oil tube	送り土台配管	1
9	35-8310-0	Upper shaft piping joint	上シャフト配管ジョイント	1
10	35-3140-0	Vinyl tube (125L)	ビニールチューブ125L	1
11	35-9040-0	Connecting	立ロッド配管	1
12	35-9000-0	Nut	立ロッド配管用ナット	1
13	35-3150-0	Vinyl tube (190L)	ビニールチューブ190L	1
14	35-3240-0	Vinyl tube (250L)	ビニールチューブ250L	2
15	35-8290-0	Oil return pipe	面板オイルバックパイプC	1
16	35-1610-0	Mounting bracket A	パイプ取付金具A	1
17	84-3610-0	Screw	ネジ	2
18	39-1380-0	Pipe support	パイプサポート	1
19	23-3060-0	Gasket	ガスケット	3
20	35-8320-0	Screw	上シャフト配管ジョイントネジ	1
21	39-8030-0	Oil fence	オイルフェンス	1
22	39-8060-0	Oil fence rubber	オイルフェンスゴム	1
23	84-4620-0	Screw	ネジ	2
24	23-9070-0	Machine bed felt	ベット用フェルト	1
25	35-9020-0	Screw	振元レバー注油ネジ	1
26	23-3410-0	Felt	フェルト	1
27	84-5210-0	Screw	ネジ	1
31	23-3430-0	Oil back felt	オイルバックフェルト	1
32	35-8390-0	Oil back joint	オイルバックジョイント	1
36	31-1950-0	Oil tank	オイルタンク	1
37	23-9060-0	Oil tank mesh	オイルタンクメッシュ	1
38	23-9050-0	Oil tank gasket	オイルタンクパッキン	1
39	84-5640-0	Screw	ネジ	4
40	23-3040-0	Seal	シール	1
41	87-3110-0	Screw	ネジ	1
42	31-2220-0	Oil filter	オイルフィルター	1
43	23-9130-0	Gasket	パッキン	1
44	35-9150-0	Oil filter plate	オイルフィルター受け	1
45	84-7610-0	Screw	ネジ	4
46	23-9110-0	Washer	ワッシャ	5
47	87-1880-0	Screw	ネジ	5
48	87-1830-0	Screw	ネジ	1
49	75-4520-0	Washer	ワッシャ	6
50	31-4190-0	Pump mounting rear plate	ポンプ取付裏板	1
52	31-4090-0	Worm gear	ウォームギヤ	1
53	84-5210-0	Screw	ネジ	1
54	84-5110-0	Screw	ネジ	1
56	75-4700-0	Washer	ワッシャ	1
57	93-2230-0	E-ring	E型止め輪	1
58	35-1070-0	Filter inlet	ポンプ吸口	1
59	84-5720-0	Screw	ネジ	2
60	35-4030-0	Oil separator	オイルセパレーター	1
61	23-1640-0	Gasket	ガスケット	2
62	75-4700-0	Washer	ワッシャ	1
63	35-8220-0	Screw	ポンプ配管ネジ	1
64	31-3140-0	Tube joint	チューブジョイント	2
65	84-6610-0	Screw	ネジ	1
66	31-3140-0	Tube joint	チューブジョイント	2
67	35-9140-0	Pipe support	パイプサポート	1
68	23-1600-0	Seal	配管油止めシール	1
69	84-5660-0	Screw	ネジ	1
70	35-9120-0	Joint	配管ジョイント	1
71	84-3610-0	Screw	ネジ	1
72	35-3180-0	Vinyl tube (440L)	ビニールチューブ440L	1
73	39-1390-0	Pipe support	パイプサポート	1

5. Needle lever crank (クランク機構)

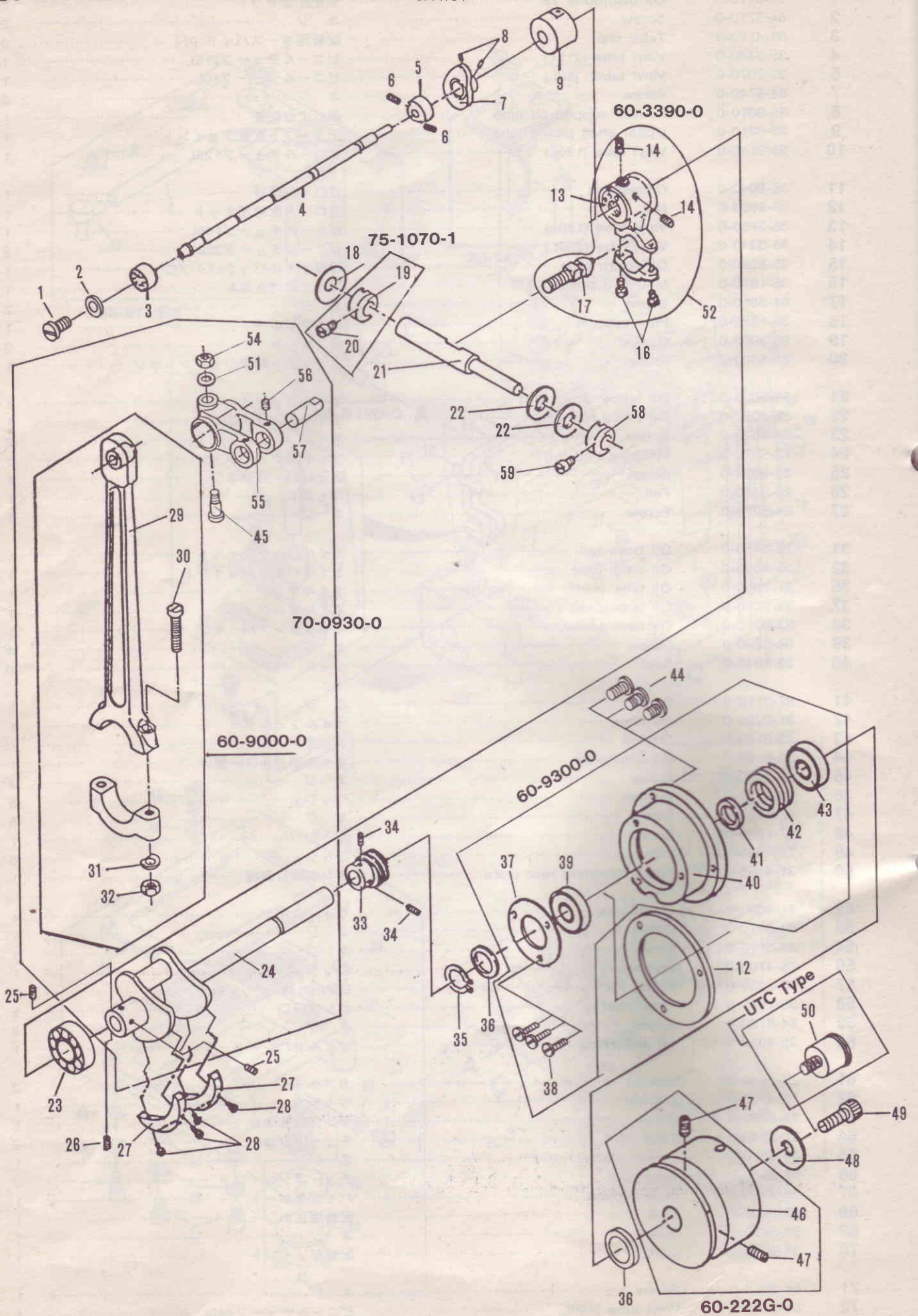

No.	Part No.	Part Name	品名	Q, ty
1	84-7610-0	Screw	ネジ	1
2	75-3870-0	Washer	ワッシャ	1
3	91-9070-0	Main shaft front bearing	下シャフト前ベアリング	1
4	71-9290-0	Main shaft	下シャフト	1
5	69-1520-0	Balance weight	バランスウェイト	1
6	84-5210-0	Screw	ネジ	2
7	49-1440-1	Looper thread double disc take up	ハマグリ	1
8	84-7110-0	Screw	ネジ	2
9	81-9090-0	Bushing	下シャフトブッシュ	1
12	98-6140-0	Gasket	バックリング	1
13	61-5140-0	Looper driving eccentric	エキセン玉	1
14	85-1130-0	Screw	ネジ	2
16	84-5720-0	Screw	ネジ	2
17	61-7130-U	Looper driving eccentric ball	振り元ロッド玉	1
18	75-3220-0	Washer	ワッシャ	1
19	75-1070-0	Looper driving shaft clame	ルーパー振り元止めカラー	1
20	85-2120-0	Screw	ネジ	1
21	71-9200-0	Looper driving shaft	ルーパー振り元軸	1
22	75-3320-0	Washer	ワッシャ	2
23	91-8960-0	Ball bearing	ボールベアリング	1
24	71-9300-0	Crank shaft	クランクシャフト	1
25	84-7180-0	Screw	ネジ	2
26	84-7190-0	Screw	ネジ	1
27	69-1470-0	Balance	バランス	2
28	84-5790-0	Screw	ネジ	4
29	60-9000-0	Needle bar crank rod	針棒クランクロッド	1
30	84-6210-0	Screw	ネジ	2
31	75-3880-0	Washer	ワッシャ	2
32	86-3150-0	Nut	ナット	2
33	31-4150-0	Pump worm gear	ポンプウォームギヤー	1
34	84-7180-0	Screw	ネジ	2
35	94-8100-0	C-ring	C-リング	1
36	75-8140-0	Washer	スラストワッシャ	2
37	69-1530-0	Bearing stop plate	ベアリング止め板	1
38	84-5630-0	Screw	ネジ	3
39	91-9020-0	Ball bearing	ボールベアリング	1
40	69-3110-0	Flange	フレンジ	1
41	75-1600-0	Spacer collar	スペースカラー	1
42	79-0600-0	Flange plate spring	皿バネ	4
43	91-9030-0	Ball bearing	ボールベアリング	1
44	84-5660-0	Screw	ネジ	3
45	71-4550-0	Pin	立てロッド連結レバー止めピン	1
46	69-222G-0	Hand wheel	ブリー	1
47	85-1140-0	Screw	ネジ	2
48	75-1830-0	Washer	ワッシャ	1
49	87-2630-0	Screw (without UTC)	ネジ (UTC除く)	1
50	06-9580-0	Needle positioner adapter (UTC)	ポジションナーセットネジ (UTCノミ)	1
51	75-5520-0	Washer	ワッシャ	1
52	60-3390-0	Looper drive eccentric set	振り元ロッドセット	1セット
54	86-5010-0	Nut	ナット	1
55	67-8020-0	Crank rod lever	立ロッド連結レバー	1
56	84-5210-0	Screw	ネジ	2
57	71-5060-0	Pin	立ロッドピン	1
58	75-1120-1	Collar	カラー	1
59	84-5630-0	Screw	ネジ	1

6. Feed rocker (送り機構)

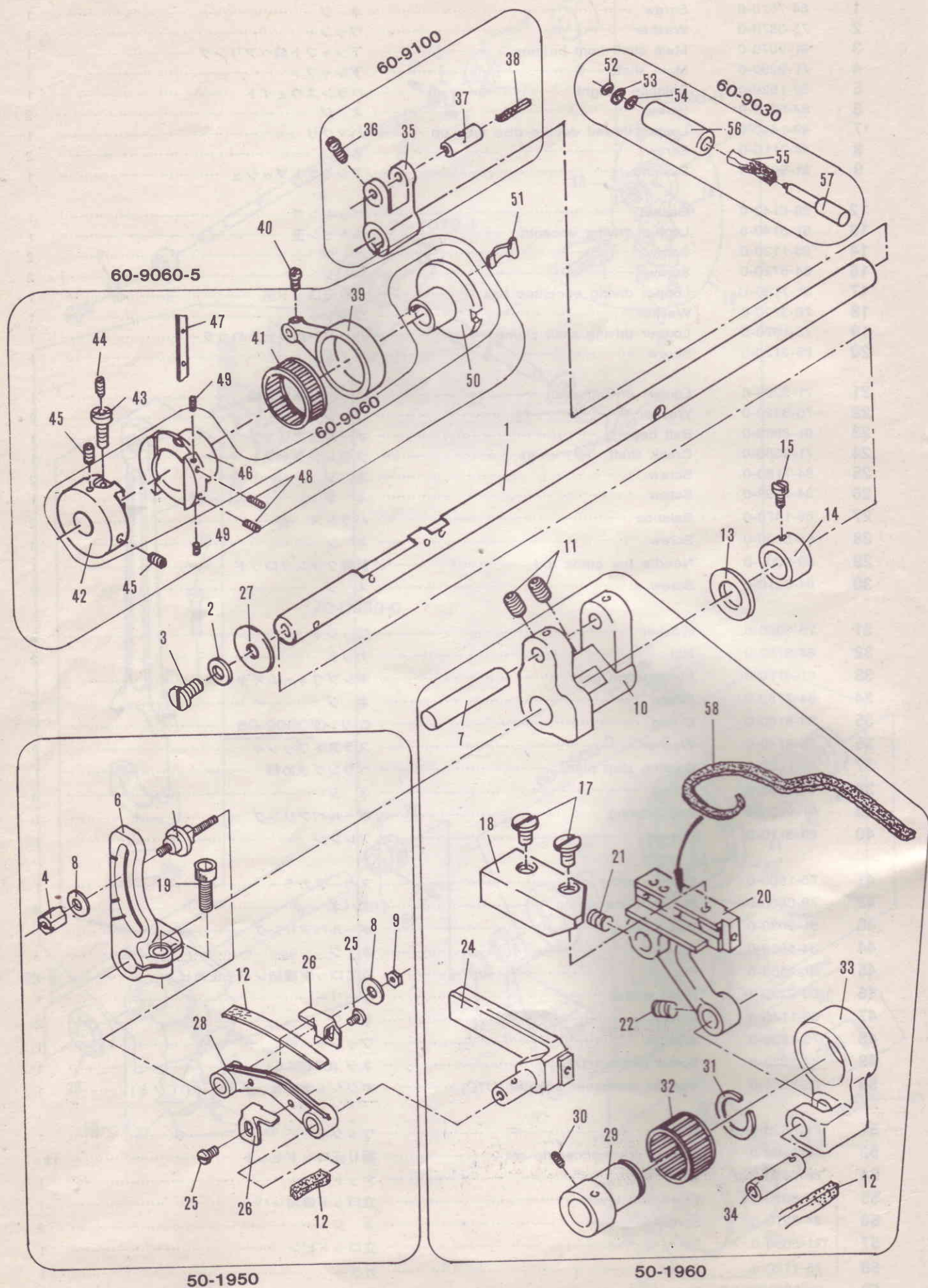

No.	Part No.	Part Name	品名	Q, ty
1	71-9470-0	Foot rocker shaft	送り土台シャフト	1
2	75-4100-0	Washer	ワッシャ	1
3	84-5660-0	Screw	ネジ	1
4	86-3160-0	Nut	ナット	1
5	51-9130-0	Pin	差動比調節ピン	1
6	51-9150-0	lever	差動比調節レバー	1
7	71-9450-0	Shaft	送り土台連結シャフト	1
8	75-3820-0	Washer	ワッシャ	2
9	86-3110-0	Nut	ナット	1
10	51-9140-0	Feed rocker	送り元台	1
11	84-7180-0	Screw	ネジ	2
12	23-3410-0	Eelt	フェルト	3
13	75-1870-0	Washer	ワッシャ	1
14	75-1880-1	Collar B	ルーバー台シャフト締めカラーB	1
15	84-8140-0	Pin	締めカラー止めピン	1
17	84-5740-0	Screw	ネジ	2
18	51-9060-0	Guide	スラスト金具	1
19	87-1710-0	Screw	ネジ	1
20	51-9110-0	Feed rocker	送り土台	1
21	84-5210-0	Screw	ネジ	1
22	84-3660-0	Screw	ネジ	1
24	51-9020-0	Differential feed bar	差動送り歯取付台	1
25	84-3790-0	Screw	ネジ	2
26	23-9000-0	Felt clamp	フェルト押え金具	2
27	75-4140-0	Washer	ワッシャ	1
28	51-9040-0	Differential feed link	差動調節メガネ	1
29	61-3140-0	Looper avoid eccentric	針返しエキセン玉	1
30	84-5210-0	Screw	ネジ	2
31	93-4060-0	Retaining ring	スナップリング	1
32	91-4060-0	Bearing	ベアリング	1
33	63-9050-0	Feed rocker link	送りダルマ	1
34	71-4340-0	Pin	糸寄せメガネピン	1
35	67-9100-0	Feed connecting lever	送り連結レバー	1
36	84-8140-0	Screw	ネジ	1
37	71-4340-0	Feed rocker driving rod pin	ダルマピン	1
38	23-3410-0	Felt	フェルト	1
39	63-9030-0	Feed rocker driving rod	送り連結ダルマ	1
40	84-6160-0	Screw	ネジ	1
41	91-2720-0	Bearing	ベアリング	1
42	61-9060-0	Feed rocker eccentric	エキセンスラストホイール	1
43	87-1700-0	Screw	ネジ	1
44	87-1380-0	Screw	ネジ	1
45	85-1130-0	Screw	ネジ	2
46	61-3290-0	Feed eccentric regulator	送りエキセン	1
47	69-7020-0	Spacer	エキセンライナー	1
48	87-1350-0	Screw	ネジ	2
49	87-1390-0	Screw	ネジ	2
50	61-3300-0	Feed crank adjust ment post eccentric	送り調節エキセン	1
51	79-5160-0	Plata spring	板バネ	1
52	93-2050-0	E-ring	Eリング	1
53	75-4520-0	Washer	ワッシャ	1
54	23-1830-0	O-ring	Oリング	1
55	79-4030-0	Spring	バネ	1
56	69-4160-0	Feed crank adjust housing	送り調節ハウジング	1
57	69-4200-0	Feed regulator push button	送り目調節ボタン	1
58	23-4160-0	Felt	フェルト	1

7. Looper (ルーパー機構)

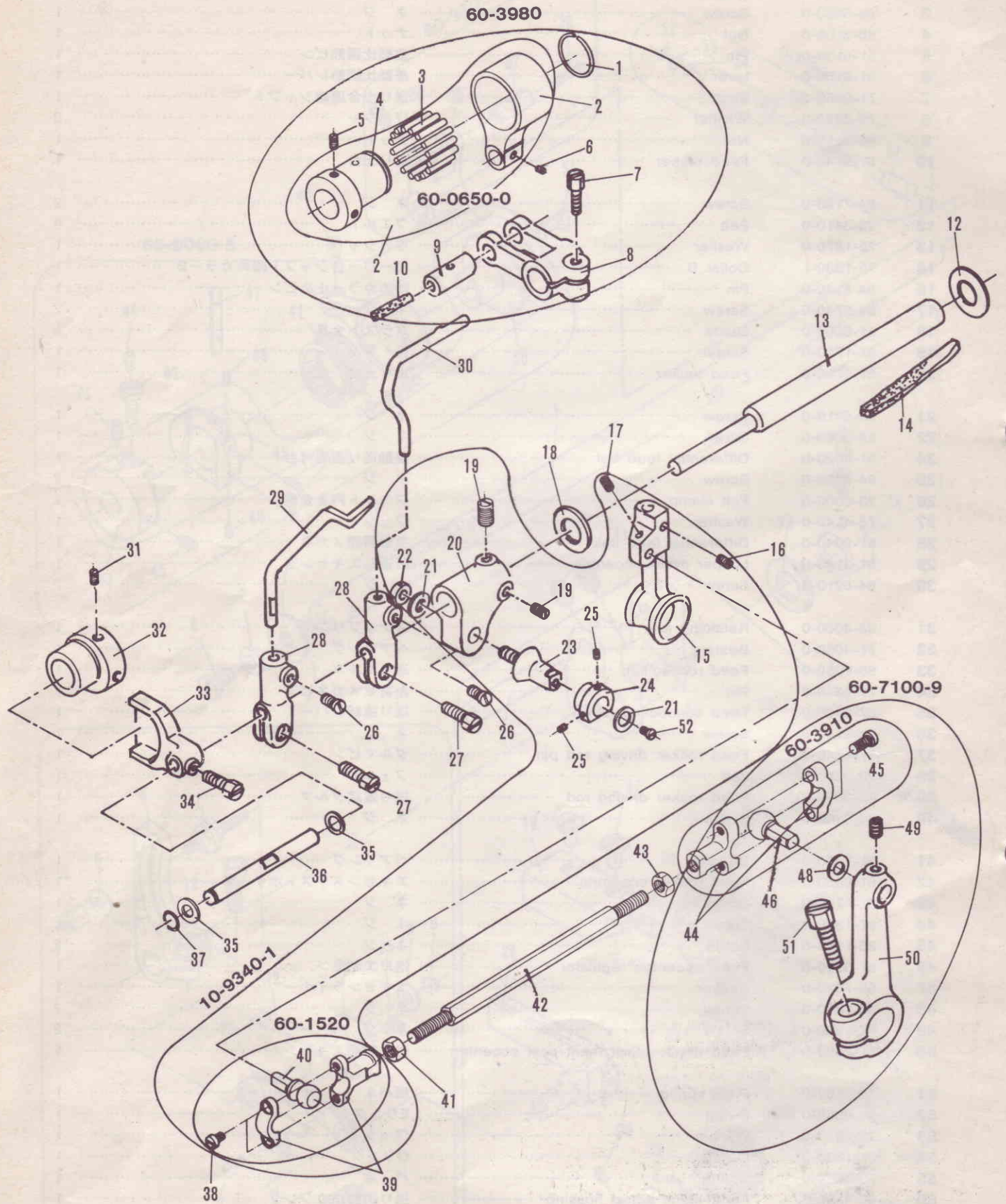

No.	Part No.	Part name	品 名	Q, ty
1	93-4060-0	C-ring	Cリング	1
2	60-0650-0	Looper aroid eccentric link	送り上下エキセンダルマ	1
3	91-4060-0	Bearing	ベアリング	1
4	61-9040-U	Looper aroid eccentric	針返しエキセン玉	1
5	84-5210-0	Screw	ネジ	2
6	84-3660-0	Screw	ネジ	1
7	84-8170-0	Screw	ネジ	1
8	67-9090-0	Looper rocker shaft	針返しダルマレバー	1
9	71-4310-0	Link pin	ダルマピン	1
10	23-3410-0	Felt	フェルト	1
11	84-6110-0	Screw	ネジ	1
12	75-3830-0	Washer	ワッシャ	1
13	71-9340-0	Looper rocker shaft	ルーパー台シャフト	1
14	23-3410-0	Felt	フェルト	1
15	19-9000-0	Looper holder	ルーパー台	1
16	84-6160-0	Screw	ネジ	1
17	84-7180-0	Screw	ネジ	1
18	75-3720-0	Washer	ワッシャ	1
19	84-8160-0	Screw	ネジ	2
20	19-9020-0	Looper rocker	ルーパー元台	1
21	75-3810-0	Washer	ワッシャ	2
22	86-4110-0	Nut	ナット	1
23	71-9350-0	Looper holder tapered pin	ルーパー台テーパードピン	1
24	81-4030-1	Taper pin bushing	テーパードピン押しブッシュ	1
25	84-5210-0	Screw	ネジ	2
26	84-3790-0	Screw	ネジ	2
27	84-6120-0	Screw	ネジ	2
28	18-9000-0	Needle guard holder	針受けブラケット	2
29	18-9020-0	Needle guard	針受け	1
30	18-1020-0	Needle bar guide	針ガイド	1
31	84-5210-0	Screw	ネジ	2
32	61-9050-0	Needle guard eccentric	針受けエキセン	1
33	18-9010-0	Needle guard rocker lever	針受け駆動レバー	1
34	84-6120-0	Screw	ネジ	1
35	98-2160-0	Washer	ワッシャ	2
36	71-9170-0	Needle guard shaft	針受けシャフト	1
37	93-2110-0	E-ring	Eリング	1
38	84-1720-0	Screw	ネジ	2
39	63-1030-1	Looper connecting rod	ルーパー連結ロッド	1
40	61-1010-0	Connecting ball	ルーパー連結ロッド玉	1
41	86-4120-0	Nut	ナット	1
42	65-3200-0	Connecting bar	ルーパー振り連結棒	1
43	86-4110-0	Nut	ナット	1
44	63-8110-1	Connecting rod	連結ロッド (右)	1
45	84-5670-0	Screw	ネジ	2
46	61-5130-U	Connecting ball	ロッド玉	1
48	75-4010-0	Washer	ワッシャ	1
49	84-7180-0	Screw	ネジ	1
50	67-1000-0	Looper drive lever	振り元レバー	1
51	85-2100-0	Screw	ネジ	1
52	84-4010-0	Screw	ネジ	1

8. Arm shaft mechanism (上軸機構)

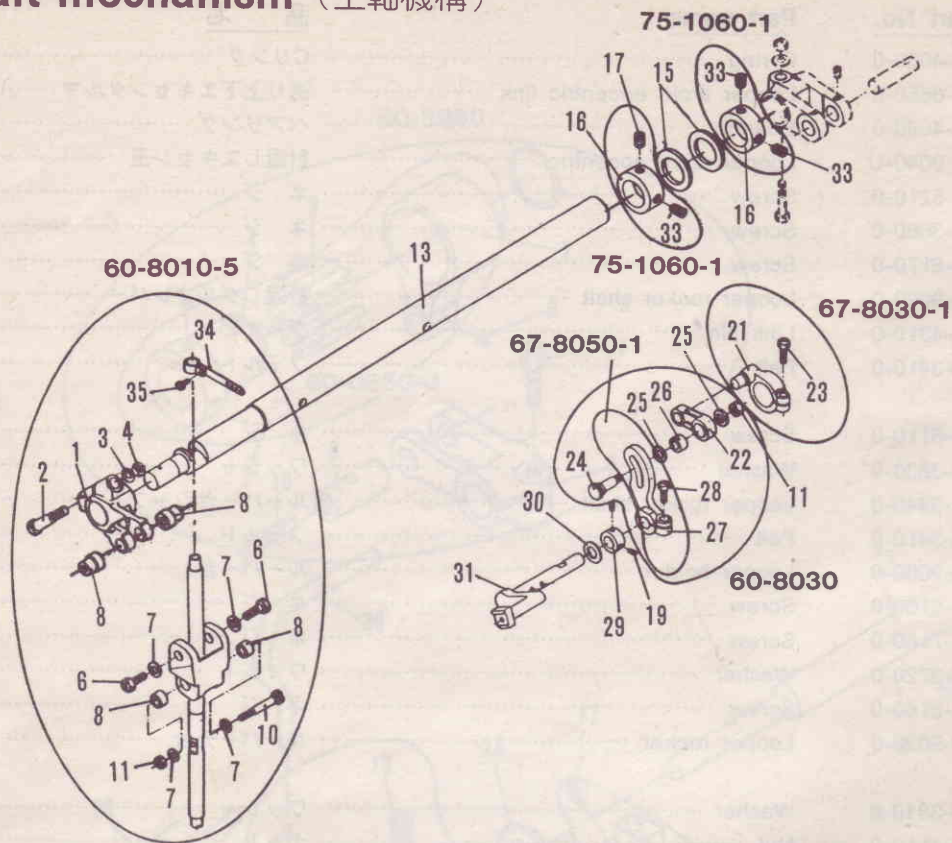

No.	Part No.	Part name	品名	Q, ty
1	67-8010-0	Needle bar crank lever	針棒クランクレバー	1
2	71-4550-0	Pin	立ロット連結レバー止めピン	1
3	75-3810-0	Washer	ワッシャ	1
4	86-5010-0	Nut	ナット	1
5	71-5010-0	Link collar	リンクカラー	2
6	84-4010-0	Screw	ネジ	2
7	75-5220-0	Washer	ワッシャ	4
8	75-2490-0	Washer	ワッシャ	2
9	66-8020-0	Needle bar joint	針棒リンク	1
10	84-6170-0	Screw	ネジ	1
11	86-3110-0	Nut	ナット	2
12	11-8040-0	Needle bar	針棒	1
13	71-6930-0	Upper shaft C	上シャフト	1
15	75-3060-0	Washer	ワッシャ	2
16	75-1060-1	Collar	カラー	2
17	85-2130-0	Screw	ネジ	1
19	84-5110-0	Screw	ネジ	2
21	67-8030-1	Crank Irod lever	上糸捌き駆動レバー	1
22	66-8010-0	Thread take up regulating link	上糸調節連結リンク	1
23	84-8140-0	Screw	ネジ	1
24	84-5990-0	Screw	ネジ	1
25	75-5220-0	Washer	ワッシャ	2
26	75-2480-0	Roller	上糸調節リンクローラ	1
27	67-8050-0	Thread take up regulator	上糸捌き調節レバー	1
28	84-8140-0	Screw	ネジ	1
29	75-1520-1	Collar	カラー	1
30	75-3560-0	Washer	ワッシャ	2
31	69-8010-0	Arm crank	アームクランク	1
33	85-1130-0	Screw	ネジ	3
34	45-1810-0	Needle bar thread eyelet	針棒糸道	1
35	84-3610-0	Screw	ネジ	1

9. Spreader components (上飾り機構) R9300

R9300 Type

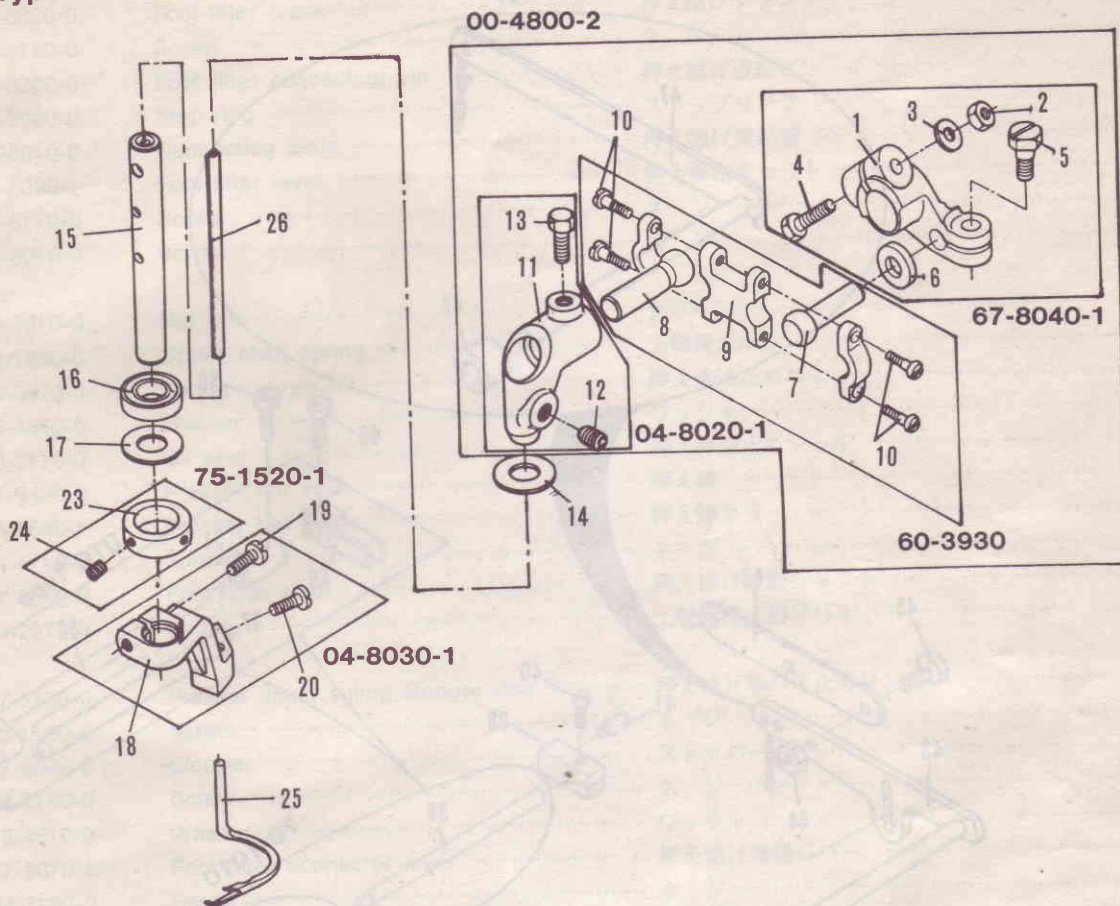

No.	Part No.	Part name	品名	Q, ty
1	67-8040-0	Covering lever	上飾り駆動レバー	1
2	86-5010-0	Nut	ナット	1
3	75-5520-0	Washer	ワッシャ	1
4	71-4550-0	Screw	ネジ	1
5	84-4130-0	Screw	ネジ	1
6	75-3980-0	Washer	ワッシャ	1
7	61-8020-U	Connecting ball B	連結ロット玉B	1
8	61-8010-U	Connecting ball A	連結ロット玉A	1
9	63-5250-1	Connecting ball joint	連結ロット	1
10	84-1720-0	Screw	ネジ	4
11	04-8020-0	Joint	ジョイント	1
12	84-7260-0	Screw	ネジ	1
13	84-6110-0	Screw	ネジ	1
14	75-3560-0	Washer	ワッシャ	1
15	71-5530-0	Shaft	シャフト	1
16	94-8010-0	Oil seal	オイルシール	1
17	75-1800-0	Washer	ワッシャ	1
18	04-8030-0	Top cover looper holder	上飾りルーパー土台	1
19	84-5670-0	Screw	ネジ	1
20	84-3630-0	Screw	ネジ	1
23	75-1520-0	Coller	カラー	1
24	84-5110-0	Screw	ネジ	2
25	19-8080-0	Top cover looper	上飾りルーパー	1
26	23-3410-0	Felt	フェルト	1

10. Foot lifter mechanism (押え揚げ機構)

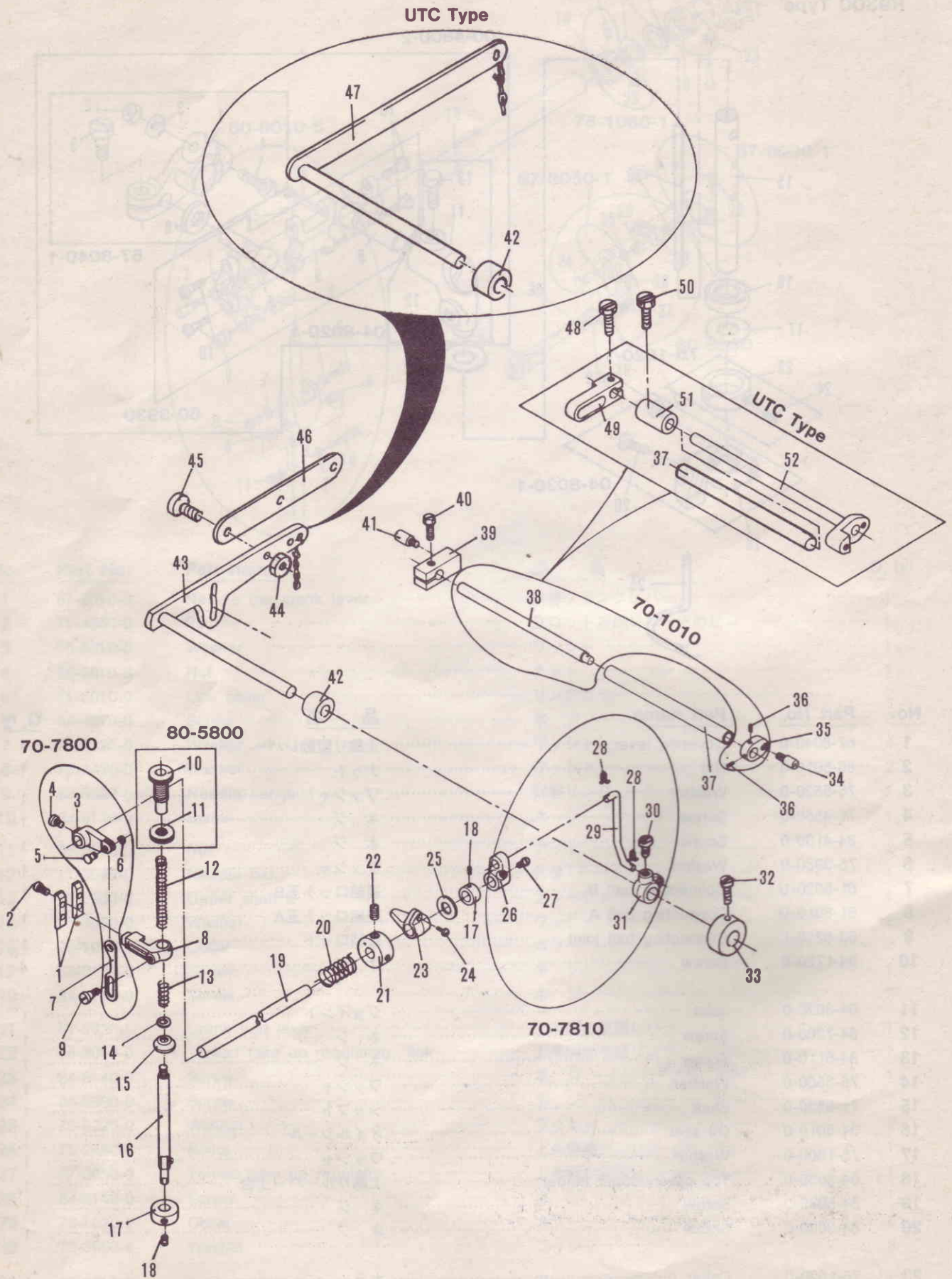

No.	Part No.	Part name	品名	Q, ty
1	77-1390-0	Foot lifter guide	押え棒案内板	2
2	84-5670-0	Screw	ネジ	4
3	77-8020-0	Foot lifter crank	押え揚げクランク	1
4	84-8160-0	Screw	ネジ	1
5	71-3260-0	Foot lifter connecting pin	押え揚げ連結ピン	1
6	93-2000-0	Stop ring	ストップリング	1
7	77-8010-0	Connecting plate	押え揚げ連結板	1
8	77-8030-1	Foot lifter lever	押え棒抱きセット	1
9	84-8170-0	Screw	ネジ	1
10	85-8010-0	Screw	ネジ	1
11	86-8510-0	Nut	ナット	1
12	79-1230-0	Upper shaft spring	上軸押えバネ	1
13	79-0420-0	Spring	押え棒油止めバネ	1
14	75-4360-0	Washer	ワッシャ	1
15	23-3110-0	Oil seal	押え棒油止めシール	1
16	71-5430-0	Presser bar shaft	押え棒	1
17	75-1540-1	Presser bar collar	押え棒カラー	2
18	84-5110-0	Screw	ネジ	2
19	71-5540-0	Foot lifter shaft	押え揚げ連動シャフト	1
20	79-2270-0	Spring	上軸用押え揚げバネ	1
21	77-8150-0	Presser lifting spring stopper ring	押え揚げ巻バネ止めリング	1
22	85-1130-0	Screw	ネジ	2
23	77-8040-0	Stopper	ストッパー	1
24	84-8140-0	Screw	ネジ	1
25	75-4510-0	Washer	ワッシャ	1
26	77-8070-1	Foot lifter connector lever	押え揚げ連結レバー	1
27	84-7180-0	Screw	ネジ	1
28	93-6110-0	Snap pin	スナップピン	2
29	77-8080-0	Foot lifter connecting bar	押え揚げ連結棒	1
30	85-2120-0	Screw	ネジ	1
31	77-8060-1	Foot lifter connect lever	押え揚げ連結レバー	1
32	84-6160-0	Screw	ネジ	1
33	75-1300-1	Shaft collar for lifting controller	押え揚げ土台カラーセット	1
34	84-5620-0	Screw	ネジ	1
35	77-1010-0	Lifter lever connection (without UTC)	丸駒 (UTC除外)	1
36	84-5210-0	Screw	ネジ	2
37	77-1210-0	Foot lifter crank shaft pipe	押え揚げクランクシャフトパイプ	1
38	77-1110-0	Foot lifter crank shaft A	押え揚げクランク軸	1
39	77-1030-0	Adjusting post supporter	調子心棒止め板 (UTC除外)	1
40	84-8120-0	Screw	ネジ	1
41	84-5610-0	Screw	ネジ	1
42	75-8880-0	Foot lifter connecting collar	押え揚げスペースカラー	1
43	77-8880-0	Presser foot lifter lever control	押え揚げコントロールレバー	1
44	86-4110-0	Nut	ナット	2
45	84-8120-0	Screw	ネジ	2
46	77-8140-0	Foot lifter connecting plate	押え揚げレバー連結板	1
47	77-8890-0	Presser foot lifter lever control	押え揚げコントロールレバー	1
48	84-8120-0	Screw	ネジ	1
49	06-6220-0	Tension release lever (UTC)	糸弛めレバー (UTCノミ)	1
50	84-6160-0	Screw	ネジ	1
51	75-1220-0	Presser lifter shaft collar	押え揚げシャフトカラー	1
52	06-6230-0	Tension release cam shaft	糸弛めカム軸	1

11. Wiper (ワイパー機構) R9200A, C/UTC Type

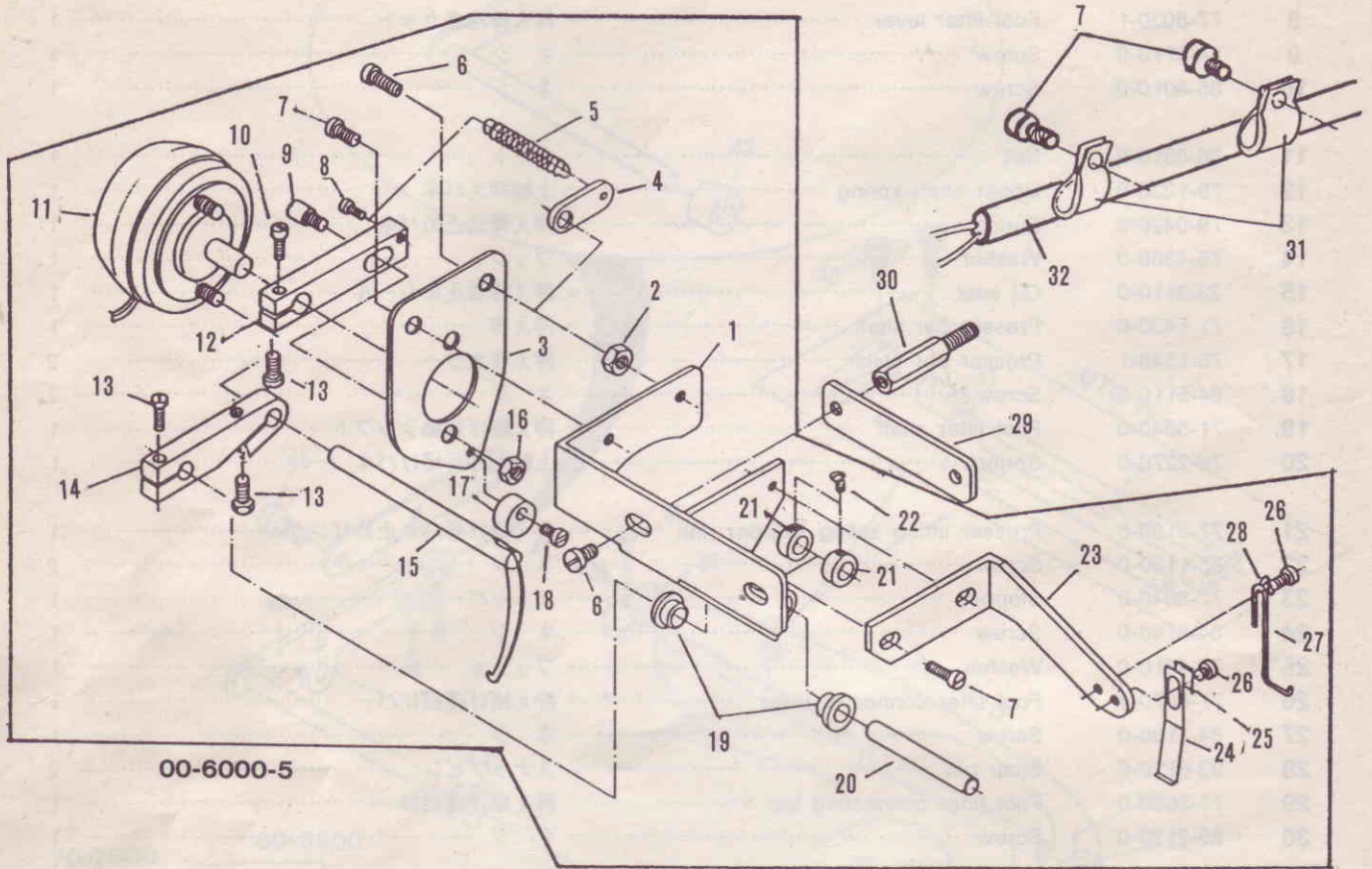

No.	Part No.	Part Name	品 名	Q, ty
1	06-6890-0	Wiper bracket	糸払いブラケット	1
2	86-3110-0	Nut	ナット	1
3	06-6790-0	Solenoid bracket	ソレノイドブラケット	1
4	06-6840-0	Wiper spring stopper bracket	糸払いバネ止め金具	1
5	79-7030-0	Spring	メスクッションバネ	1
6	84-5660-0	Screw	ネ ジ	3
7	84-5640-0	Screw	ネ ジ	7
8	84-1610-0	Screw	ネ ジ	1
9	84-7060-0	Screw	ネ ジ	1
10	84-3140-0	Screw	ネ ジ	1
11	06-6770-0	Wiper solenoid	上糸払いソレノイド	1
12	06-6800-0	Solenoid connecting lever	ソレノイド連結レバー	1
13	84-4130-0	Screw	ネ ジ	3
14	06-6740-0	Wiper lever	糸払いレバー	1
15	06-6750-0	Wiper	糸払いワイパー	1
16	88-1460-0	Nut	ナット	2
17	06-6830-0	Wiper adjusting bracket	糸払いアジャスト金具	1
18	87-1380-0	Screw	ネ ジ	1
19	06-6820-0	Bushing	ブッシュ	2
20	06-6810-0	Wiper drive shaft	ワイパー駆動軸	1
21	75-0970-0	Collar	ゴム案内装置ストップカラー	2
22	84-3610-0	Screw	ネ ジ	2
23	06-6710-0	Thread catching bracket	糸掴みブラケット	1
24	06-6760-0	Thread catching spring	糸掴み板バネ	1
25	06-6330-0	Plate spring washer	板バネ用角ワッシャ	1
26	84-3640-0	Screw	ネ ジ	2
27	06-6780-0	Upper thread catching spring	上糸払い用糸掴みバネ	1
28	75-4680-0	Tubing fixing washer	配管取付けワッシャ	1
29	06-6730-0	Wiper bracket space liner	糸払いブラケットスペースライナー	1
30	06-7510-0	Screw	ネ ジ	2
31	06-9350-0	Wiper cord guard	パイプサポーター	4
32	06-3010-0	Wiper cord	配線コード	1

12. Covering Thread Under trimming Knife (上飾り糸 糸切り機構)

R9300/UTC Type

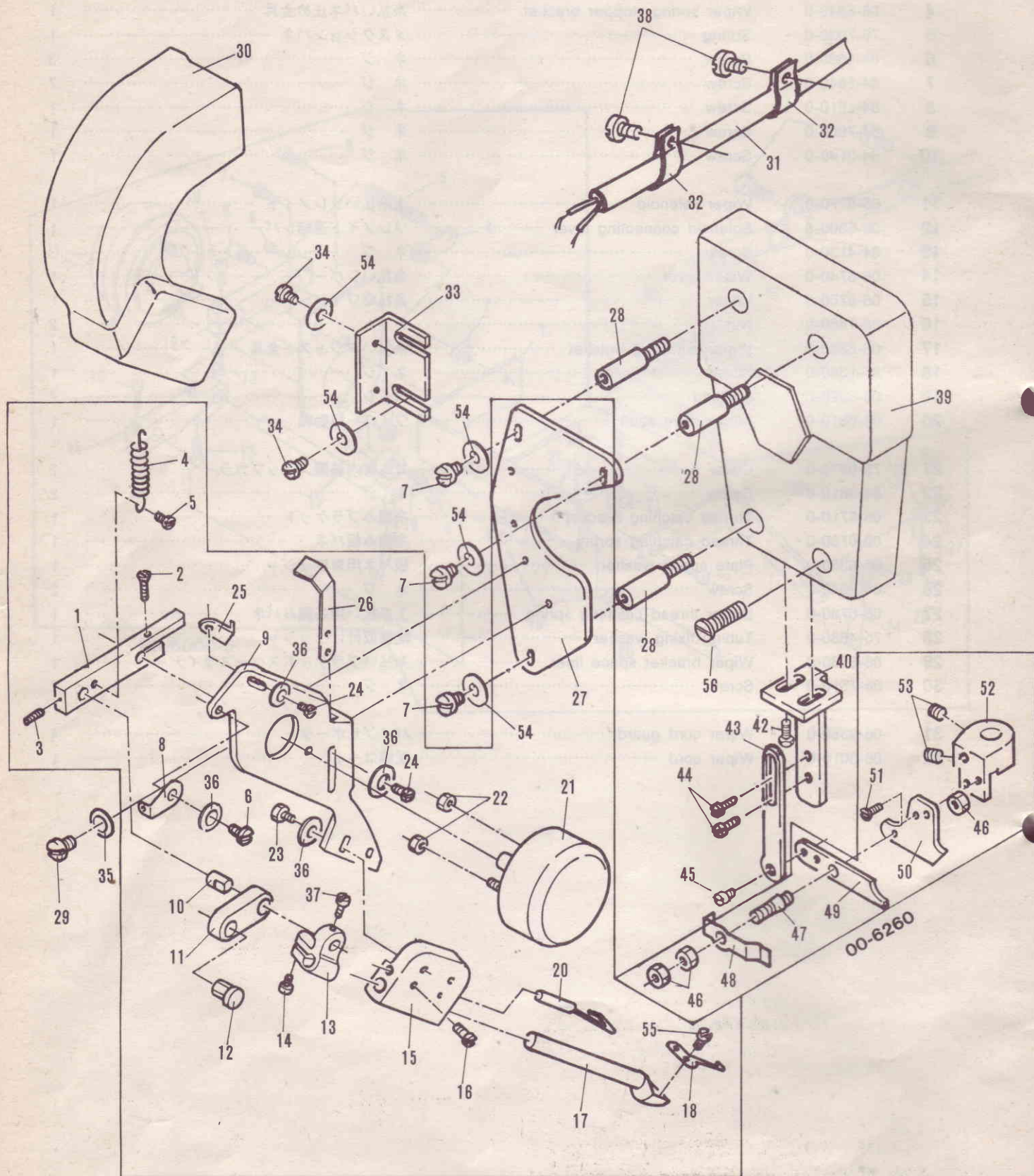

No.	Part No.	Part Name	品名	Q, ty
1	06-6430-0	Needle thread catching thring lever	糸摺みソレノイド回転レバー	1
2	84-4130-0	Screw	ネジ	1
3	84-5210-0	Screw	ネジ	1
4	79-7030-0	Spring	メスクッションバネ	1
5	84-1710-0	Screw	ネジ	1
6	84-5750-0	Screw	ネジ	1
7	84-5660-0	Screw	ネジ	3
8	06-6500-0	Needle thread catching spring adjuster	糸摺みバネアジャスター	1
9	06-6390-0	Solenoid thread catching spring adjuster	ソレノイド取付板	1
10	71-1620-0	Needle thread catching link pin	糸摺みリンクピン	1
11	66-1020-0	Link	上糸払い連結リンク	1
12	71-1610-0	Needle thread catching link pin	糸摺みリンクピン	1
13	73-1130-1	Needle bar connection	針棒抱きC	1
14	84-5640-0	Screw	ネジ	5
15	06-6450-0	Needle thread catching shaft bearing	糸摺み軸受け	1
16	84-3140-0	Screw	ネジ	2
17	06-6440-0	Needle thread catching shaft bearing	糸摺みスライド軸	1
18	06-6520-0	Wiper	ワイパー	1
20	06-6530-0	Needle thread catching spring	上糸摺みバネ	1
21	06-6770-0	Upper solenoid	上糸払いソレノイド	1
22	88-1460-0	Nut	ナット	2
23	84-6110-0	Screw	ネジ	2
24	84-3660-0	Screw	ネジ	4
25	06-6490-0	Needle thread catching solenoid stopper	糸摺みソレノイドストッパーB	1
26	06-6480-0	Needle thread catching solenoid stopper	糸摺みソレノイドストッパーA	1
27	06-6370-0	Needle thread catching bracket	上糸摺みブラケット	1
28	84-6250-0	Screw	ネジ	3
29	84-6110-0	Screw	ネジ	2
30	21-140W-0	Needle thread catching solenoid cover	糸摺みソレノイドカバー	1
31	06-3010-0	Wire	ソレノイド配線コード	1
32	06-9350-0	Wiper cord guard	パイプサポーター	4
33	06-0250-0	Solenoid cover bracket	ソレノイドカバーブラケット	1
34	84-5710-0	Screw	ネジ	4
35	75-4670-0	Washer	ワッシャ	2
36	75-4550-0	Washer	ワッシャ	6
37	84-3650-0	Screw	ネジ	4
38	84-5640-0	Screw	ネジ	4
39	21-806W-0	Head cover	面板 (UTCノミ)	1
40	06-0210-0	Knife adjust mechanism A	メスアジャスト金具	1
42	84-6110-0	Screw	ネジ	2
43	06-0220-0	Knife adjust mechanism B	メスアジャスト金具	1
44	84-3610-0	Screw	ネジ	2
45	85-6070-0	Screw	ネジ	1
46	86-2110-0	Nut	ナット	3
47	06-0890-0	Top cover knife adjust screw	上飾り糸切メス調節ネジ	1
48	06-0900-0	Top cover knife adjustment spring	上飾り糸切メス調節バネ	1
49	06-0870-0	Top cover knife knife B	飾り糸糸切メスB	1
50	06-0980-0	Top cover knife knife A	飾り糸糸切メスA	1
51	84-1620-0	Screw	ネジ	2
52	06-0990-0	Fixed knife mount plate	固定メス取付台	1
53	84-5210-0	Screw	ネジ	2
54	75-4550-0	Washer	ワッシャ	7
55	85-6110-0	Screw	ネジ	2
56	84-5660-0	Screw	ネジ	1

13. Under trimming knife (自動糸切りメス装置)

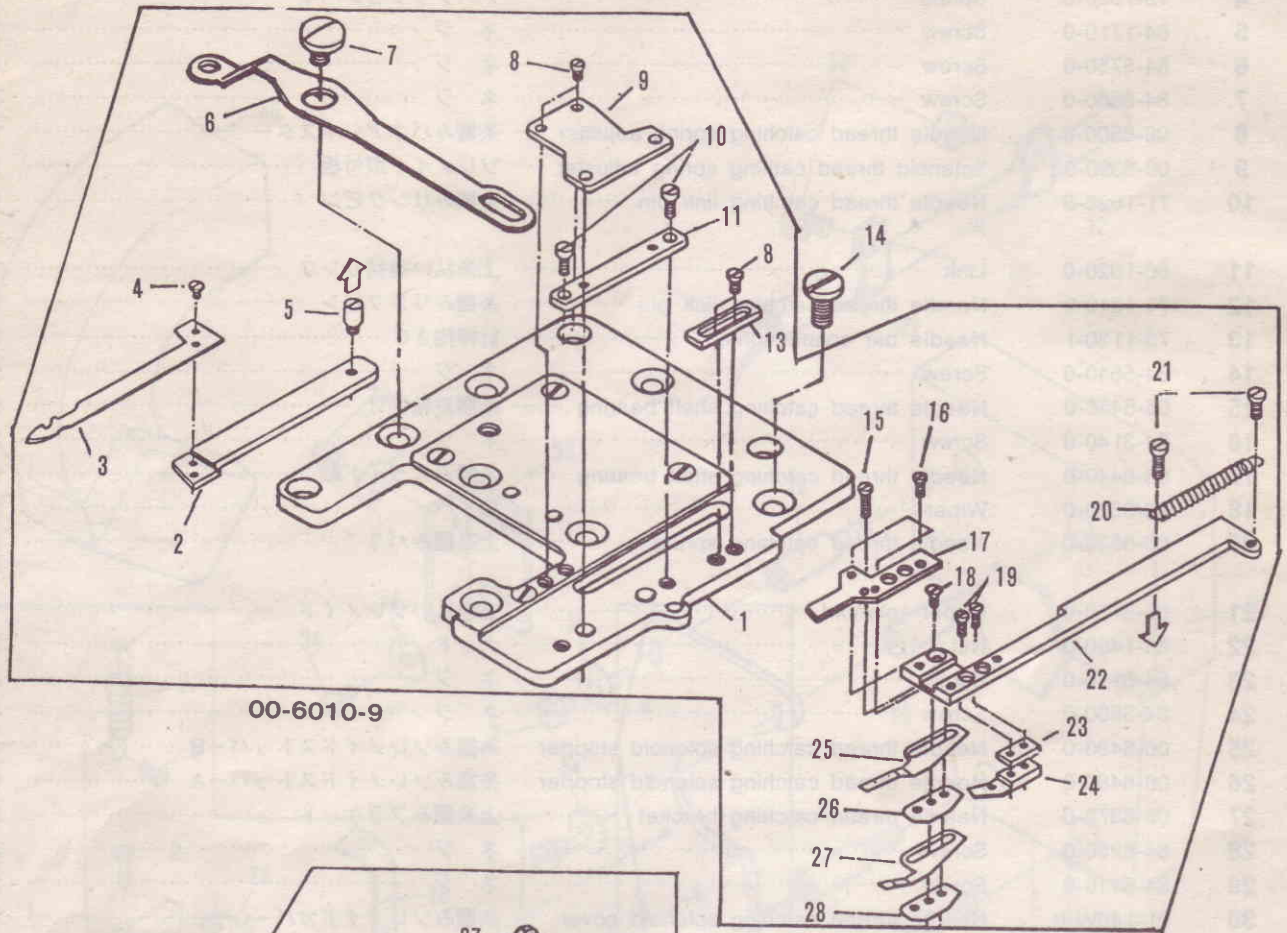

00-6010-9

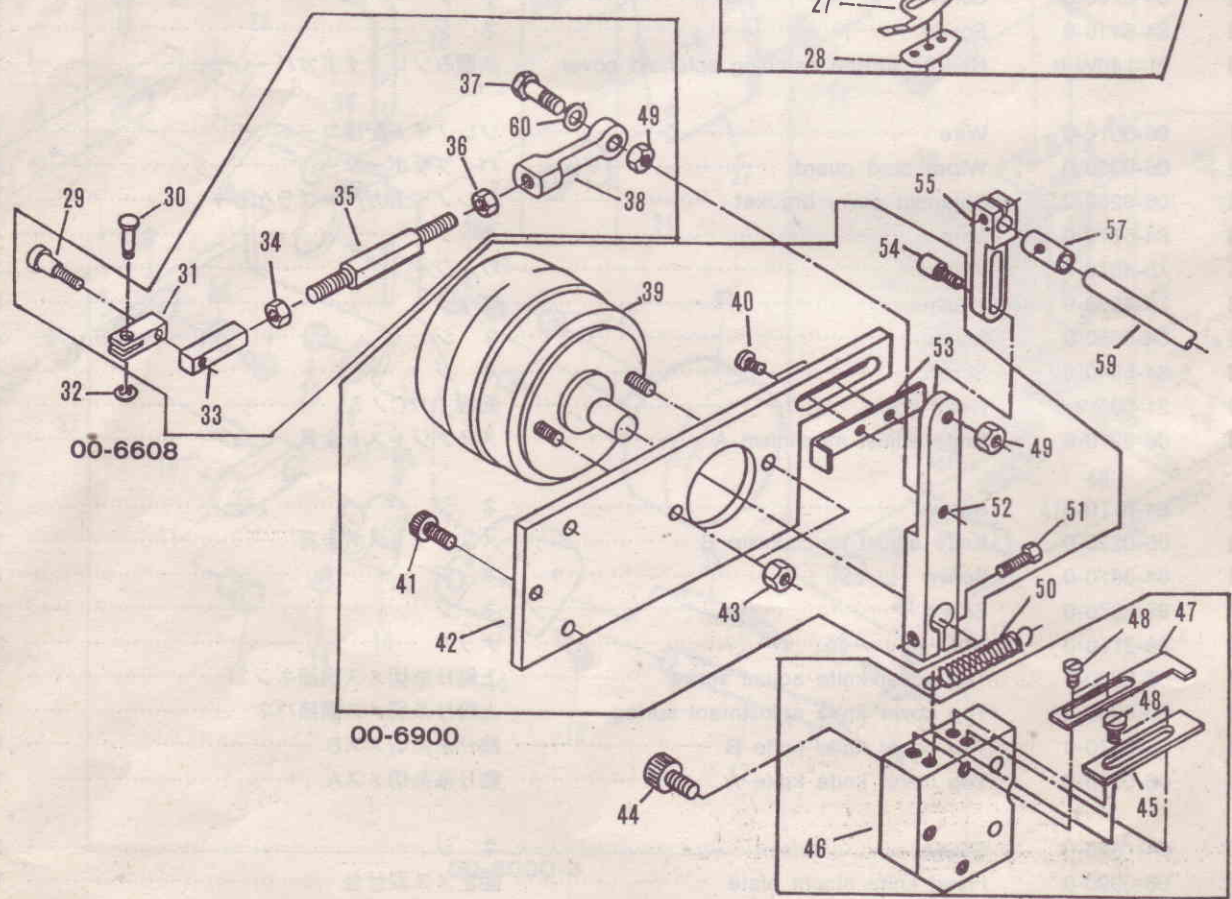

00-6608

00-6900

00-6000-4

No.	Part No.	Part Name	品名	Q, ty
1	06-9560-0	Baseplate	メスベースプレート	1
2	06-6170-0	Movable blade base	可動メスベース	1
3	06-6060-0	Movable knife	可動メス	1
4	85-1010-0	Screw	ネジ	2
5	84-2020-0	Screw	ネジ	1
6	06-9620-0	Movable knife drive lever	可動メス駆動レバー	1
7	84-1030-0	Screw	ネジ	1
8	84-1610-0	Screw	ネジ	6
9	06-6200-0	Knife holder cover	メス押えカバー	1
10	84-3610-0	Screw	ネジ	2
11	06-6160-0	Movable knife plate holder guide	可動メスベースガイド	1
13	06-6190-0	Knife plate holder adjusting plate	メスベース調節板	1
14	84-5660-0	Screw	ネジ	7
15	85-6200-0	Screw	ネジ	2
16	85-6250-0	Screw	ネジ	2
17	06-6320-0	Fixed knife	固定メス	1
18	06-6010-0	Blade rear spring stopper plate	メス裏バネ止ネジ	2
19	85-1020-0	Screw	ネジ	2
20	79-1140-0	Spring	メスクッションバネ	1
21	84-1610-0	Screw	ネジ	2
22	06-6180-0	Fixed knife base	固定メスベース	1
23	06-6300-0	Spring adjust spacer plate	バネ調節スペース板	1
24	06-6020-0	Spring adjusting liner	バネ調節ライナー	1
25	06-6050-0	Plate spring-weak	メス裏バネ弱	1
26	06-6030-0	Plate spring liner	メス裏バネライナー	1
27	06-6040-0	Plate spring-strong	メス裏バネ強	1
28	06-6080-0	Plate spring stopper plate	メス裏バネ止め板	1
29	84-6080-0	Screw	ネジ	1
30	06-6130-0	Movable knife drive pin	可動メス駆動ピン	1
31	06-6120-0	Thread cutter drive connecting rod B	メス駆動連結ロッド	1
32	93-2110-0	Stop ring	ストップリング	1
33	06-6110-0	Thread cutter drive connecting rod A	メス駆動連結ロッド	1
34	88-1570-0	Nut	ナット	1
35	06-9530-0	Thread cutter drive connecting bar	メス駆動連結棒	1
36	88-1580-0	Nut	ナット	1
37	84-6330-0	Screw	ネジ	1
38	04-3490-0	Ball joint	ロッドエント	1
39	06-8480-0	Blade solenoid	メスソレノイド	1
40	84-5660-0	Screw	ネジ	2
41	87-1730-0	Screw	ネジ	3
42	06-9550-0	Thread cutter solenoid bracket	メスソレノイドブラケット	1
43	88-1660-0	Nut	ナット	2
44	87-1730-0	Screw	ネジ	2
45	06-1600-0	Knife puling spring stopper	メス引張りバネ止め金具	1
46	06-6260-0	Thread cutter solenoid mounting bracket	メスソレノイド金具ブラケット	1
47	06-9540-0	Thread cutter solenoid stopper	メスソレノイドストッパー	1
48	84-5660-0	Screw	ネジ	4
49	86-3120-0	Nut	ナット	2
50	79-1290-0	Spring	メスソレノイド引張りバネ	1
51	84-8120-0	Screw	ネジ	1
52	06-9520-0	Thread cutter solenoid	メスソレノイドレバー	1
53	06-9510-0	Thread cutter solenoid stopper	メスソレノイドストッパー	1
54	84-1040-0	Screw	ネジ	1
55	06-6220-0	Tension release lever	糸弛めレバー	1
57	75-1220-0	Collar	押揚げシャフトカラー	1
59	06-6230-0	Tension release cam	糸弛めカム	1
60	75-4530-0	Washer	ワッシャ	1

No.	Part No.	Part Name	品 名	Q, ty
1	06-5010-0	Base plate	ベースプレート	1
2	06-5500-0	Cover (small)	カバー小	1
3	06-5030-0	Air cylinder (80mm)	シリンダー (Yナックル付) 80mm	1
4	06-5040-0	Regulator	レギュレーター本体	1
5	06-5060-0	Solenoid valve	電磁弁	1
6	06-9780-0	T-type joint	ジョイントGT4-6	1
7	06-5350-0	Foot switch with wiring harness	フットスイッチ (配線コード付)	1set
8	06-5120-0	Wire mount	線止めサドル	1
9	06-2960-0	Joint	ジョイントGS4-6	2
10	06-5150-0	Silencer	サイレンサー	2
11	06-5520-0	Foot pedal base	フットペダルベース (ネジ付)	1set
12	23-1900-0	O-ring P-10	O-リング P-10	1
13	06-3150-0	Cylinder stopper	シリンダーストッパー	1
14	06-3060-0	Wiring harness	配線コード (モレックスハウジング付)	1set
15	87-1880-0	Screw	ネジ	1
16	06-5190-0	L-type joint	ジョイント GL4-6	3
17	06-5230-0	Plug	栓	1set
18	87-1160-0	Screw	ネジ	2
19	87-2090-0	Screw	ネジ	1
20	06-3170-0	Washer	ワッシャー	1
21	06-3160-0	Screw	ネジ	5
22	06-3180-0	Screw	ネジ	2
23	09-9400-0	Air tube	ジュンロンチューブ	1
24	06-5210-0	Regulator gauge	レギュレーター用メーター	1
25	06-5170-0	Coupler	カブラオス	1
26	06-5160-0	Socket pipe	カブラメス	1
27	06-5720-0	Mark sheet No12	マークシートNo12	4
28	06-5640-0	Mark sheet No4	マークシートNo4	4
29	06-5650-0	Mark sheet No5	マークシートNo5	4
30	80-7520-0	Mounting set	ボルトセット	4set
31	06-5510-1	Y-Knuckle	シリンダー用Yナックル	1set

15. Gauge parts (ゲージ関係)

R9200A · R9200A/UTC (1/8" - 1/4")	R9300A · R9300A/UTC (1/8" - 1/4")																											
	<table border="1" style="margin-left: auto; margin-right: auto;"> <thead> <tr> <th></th> <th>mm</th> <th>Part No.</th> <th></th> </tr> </thead> <tbody> <tr> <td>1/8"</td> <td>3.17</td> <td>12-8110-1</td> <td rowspan="4" style="text-align: center;">2 Needles</td> </tr> <tr> <td>5/32"</td> <td>3.97</td> <td>12-8120-1</td> </tr> <tr> <td>3/16"</td> <td>4.76</td> <td>12-8130-1</td> </tr> <tr> <td>7/32"</td> <td>5.56</td> <td>12-8140-1</td> </tr> <tr> <td>1/4"</td> <td>6.35</td> <td>12-8150-1</td> <td rowspan="3" style="text-align: center;">3 Needles</td> </tr> <tr> <td>7/32"</td> <td>5.56</td> <td>12-8010-1</td> </tr> <tr> <td>1/4"</td> <td>6.35</td> <td>12-8020-1</td> </tr> </tbody> </table>		mm	Part No.		1/8"	3.17	12-8110-1	2 Needles	5/32"	3.97	12-8120-1	3/16"	4.76	12-8130-1	7/32"	5.56	12-8140-1	1/4"	6.35	12-8150-1	3 Needles	7/32"	5.56	12-8010-1	1/4"	6.35	12-8020-1
	mm	Part No.																										
1/8"	3.17	12-8110-1	2 Needles																									
5/32"	3.97	12-8120-1																										
3/16"	4.76	12-8130-1																										
7/32"	5.56	12-8140-1																										
1/4"	6.35	12-8150-1	3 Needles																									
7/32"	5.56	12-8010-1																										
1/4"	6.35	12-8020-1																										
Needle holder (2,3 Needles)																												
	<table border="1" style="margin-left: auto; margin-right: auto;"> <thead> <tr> <th></th> <th>mm</th> <th>Part No.</th> <th></th> </tr> </thead> <tbody> <tr> <td>1/8"</td> <td>3.17</td> <td>14-7240</td> <td rowspan="4" style="text-align: center;">2 Needles</td> </tr> <tr> <td>5/32"</td> <td>3.97</td> <td>14-7340</td> </tr> <tr> <td>3/16"</td> <td>4.76</td> <td>14-7440</td> </tr> <tr> <td>7/32"</td> <td>5.56</td> <td>14-7540</td> </tr> <tr> <td>1/4"</td> <td>6.35</td> <td>14-7640</td> <td rowspan="3" style="text-align: center;">3 Needles</td> </tr> <tr> <td>7/32"</td> <td>5.56</td> <td>14-8540</td> </tr> <tr> <td>1/4"</td> <td>6.35</td> <td>14-8640</td> </tr> </tbody> </table>		mm	Part No.		1/8"	3.17	14-7240	2 Needles	5/32"	3.97	14-7340	3/16"	4.76	14-7440	7/32"	5.56	14-7540	1/4"	6.35	14-7640	3 Needles	7/32"	5.56	14-8540	1/4"	6.35	14-8640
	mm	Part No.																										
1/8"	3.17	14-7240	2 Needles																									
5/32"	3.97	14-7340																										
3/16"	4.76	14-7440																										
7/32"	5.56	14-7540																										
1/4"	6.35	14-7640	3 Needles																									
7/32"	5.56	14-8540																										
1/4"	6.35	14-8640																										
Needle plate (2 Needles)																												
	<table border="1" style="margin-left: auto; margin-right: auto;"> <thead> <tr> <th></th> <th>mm</th> <th>Part No.</th> <th></th> </tr> </thead> <tbody> <tr> <td>1/8"</td> <td>3.17</td> <td>17-7240-1</td> <td rowspan="4" style="text-align: center;">3 Needles</td> </tr> <tr> <td>5/32"</td> <td>3.97</td> <td>17-7340-1</td> </tr> <tr> <td>3/16"</td> <td>4.76</td> <td>17-7440-1</td> </tr> <tr> <td>7/32"</td> <td>5.56</td> <td>17-7540-1</td> </tr> <tr> <td>1/4"</td> <td>6.35</td> <td>17-7640-1</td> <td rowspan="3" style="text-align: center;">3 Needles</td> </tr> <tr> <td>7/32"</td> <td>5.56</td> <td>17-7840-1</td> </tr> <tr> <td>1/4"</td> <td>6.35</td> <td>17-7940-1</td> </tr> </tbody> </table>		mm	Part No.		1/8"	3.17	17-7240-1	3 Needles	5/32"	3.97	17-7340-1	3/16"	4.76	17-7440-1	7/32"	5.56	17-7540-1	1/4"	6.35	17-7640-1	3 Needles	7/32"	5.56	17-7840-1	1/4"	6.35	17-7940-1
	mm	Part No.																										
1/8"	3.17	17-7240-1	3 Needles																									
5/32"	3.97	17-7340-1																										
3/16"	4.76	17-7440-1																										
7/32"	5.56	17-7540-1																										
1/4"	6.35	17-7640-1	3 Needles																									
7/32"	5.56	17-7840-1																										
1/4"	6.35	17-7940-1																										
Presser foot (2,3 Needles)																												
	<table border="1" style="margin-left: auto; margin-right: auto;"> <thead> <tr> <th></th> <th>mm</th> <th>Part No.</th> <th></th> </tr> </thead> <tbody> <tr> <td>1/8"</td> <td>3.17</td> <td>17-8240-1</td> <td rowspan="4" style="text-align: center;">3 Needles</td> </tr> <tr> <td>5/32"</td> <td>3.97</td> <td>17-8340-1</td> </tr> <tr> <td>3/16"</td> <td>4.76</td> <td>17-8440-1</td> </tr> <tr> <td>7/32"</td> <td>5.56</td> <td>17-8540-1</td> </tr> <tr> <td>1/4"</td> <td>6.35</td> <td>17-8640-1</td> <td rowspan="3" style="text-align: center;">3 Needles</td> </tr> <tr> <td>7/32"</td> <td>5.56</td> <td>17-8840-1</td> </tr> <tr> <td>1/4"</td> <td>6.35</td> <td>17-8940-1</td> </tr> </tbody> </table>		mm	Part No.		1/8"	3.17	17-8240-1	3 Needles	5/32"	3.97	17-8340-1	3/16"	4.76	17-8440-1	7/32"	5.56	17-8540-1	1/4"	6.35	17-8640-1	3 Needles	7/32"	5.56	17-8840-1	1/4"	6.35	17-8940-1
	mm	Part No.																										
1/8"	3.17	17-8240-1	3 Needles																									
5/32"	3.97	17-8340-1																										
3/16"	4.76	17-8440-1																										
7/32"	5.56	17-8540-1																										
1/4"	6.35	17-8640-1	3 Needles																									
7/32"	5.56	17-8840-1																										
1/4"	6.35	17-8940-1																										
Presser foot (2,3 Needles)																												
	<table border="1" style="margin-left: auto; margin-right: auto;"> <thead> <tr> <th></th> <th>mm</th> <th>Part No.</th> <th></th> </tr> </thead> <tbody> <tr> <td>1/8"</td> <td>3.17</td> <td>15-9150</td> <td rowspan="4" style="text-align: center;">3 Needles</td> </tr> <tr> <td>5/32"</td> <td>3.97</td> <td>15-9150</td> </tr> <tr> <td>3/16"</td> <td>4.76</td> <td>15-9070</td> </tr> <tr> <td>7/32"</td> <td>5.56</td> <td>15-9070</td> </tr> <tr> <td>1/4"</td> <td>6.35</td> <td>15-9070</td> <td rowspan="3" style="text-align: center;">3 Needles</td> </tr> </tbody> </table>		mm	Part No.		1/8"	3.17	15-9150	3 Needles	5/32"	3.97	15-9150	3/16"	4.76	15-9070	7/32"	5.56	15-9070	1/4"	6.35	15-9070	3 Needles						
	mm	Part No.																										
1/8"	3.17	15-9150	3 Needles																									
5/32"	3.97	15-9150																										
3/16"	4.76	15-9070																										
7/32"	5.56	15-9070																										
1/4"	6.35	15-9070	3 Needles																									
Feed dog (Rear)																												
	<table border="1" style="margin-left: auto; margin-right: auto;"> <thead> <tr> <th></th> <th>mm</th> <th>Part No.</th> <th></th> </tr> </thead> <tbody> <tr> <td>1/8"</td> <td>3.17</td> <td>15-9140</td> <td rowspan="4" style="text-align: center;">3 Needles</td> </tr> <tr> <td>5/32"</td> <td>3.97</td> <td>15-9140</td> </tr> <tr> <td>3/16"</td> <td>4.76</td> <td>15-9030</td> </tr> <tr> <td>7/32"</td> <td>5.56</td> <td>15-9030</td> </tr> <tr> <td>1/4"</td> <td>6.35</td> <td>15-9030</td> <td rowspan="3" style="text-align: center;">3 Needles</td> </tr> </tbody> </table>			mm	Part No.		1/8"	3.17	15-9140	3 Needles	5/32"	3.97	15-9140	3/16"	4.76	15-9030	7/32"	5.56	15-9030	1/4"	6.35	15-9030	3 Needles					
	mm	Part No.																										
1/8"	3.17	15-9140	3 Needles																									
5/32"	3.97	15-9140																										
3/16"	4.76	15-9030																										
7/32"	5.56	15-9030																										
1/4"	6.35	15-9030	3 Needles																									
Feed dog (front)																												
Needle guard	Loop	Needle guide																										

R9200C · R9200C/UTC (3/16" - 1/4")

R9300C · 9300C/UTC (3/16" - 1/4")

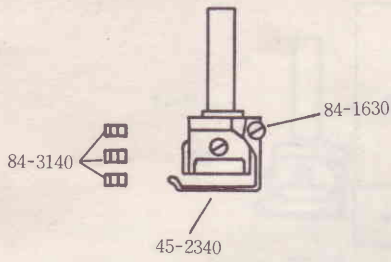

	mm	Part No.	
3/16"	4.76	12-8130-1	2 Needles
7/32"	5.56	12-8140-1	2 Needles
1/4"	6.35	12-8150-1	2 Needles
7/32"	5.56	12-8010-1	3 Needles
1/4"	6.35	12-8020-1	3 Needles

Needle holder (2,3 Needles)

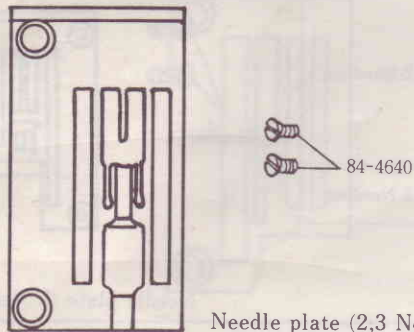

	mm	Part No.	
3/16"	4.76	14-8500	2 Needles
7/32"	5.56	14-8510	2 Needles
1/4"	6.35	14-8520	2 Needles
7/32"	5.56	14-8530	3 Needles
1/4"	6.35	14-8630	3 Needles

Needle plate (2,3 Needles)

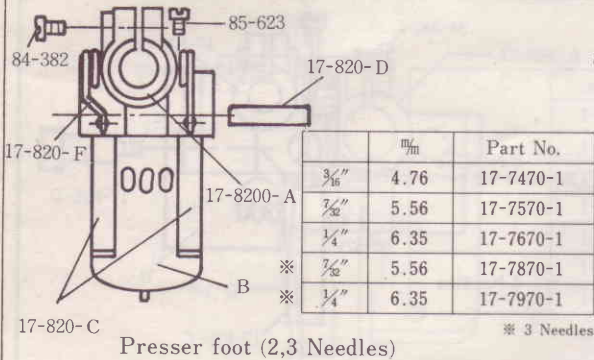

Presser foot (2,3 Needles)

※ 3 Needles

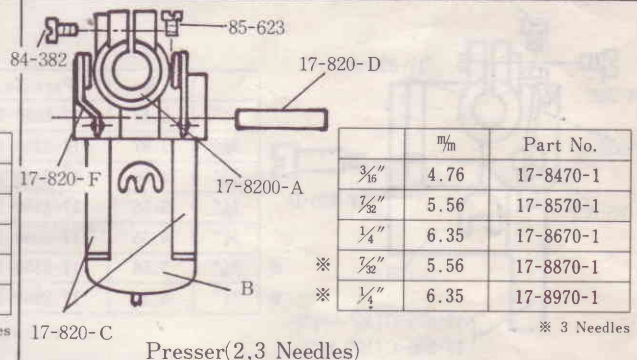

Presser (2,3 Needles)

※ 3 Needles

15-9070

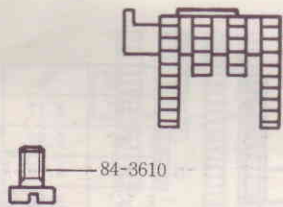

Feed dog (Rear)

15-9020

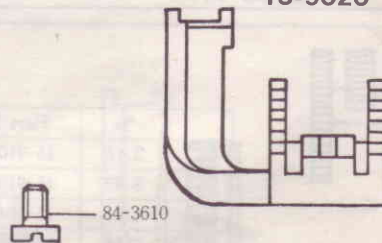

Feed dog (front)

18-9020

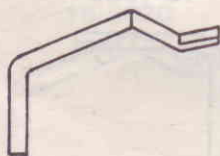

Needle guard

19-8010

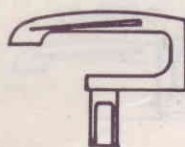

Looper

18-1020

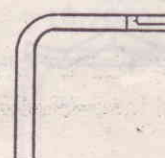

Needle guide

R9202F · R9302F (1/8" - 1/4")

R9203F · R9303F (1/32" - 1/4")

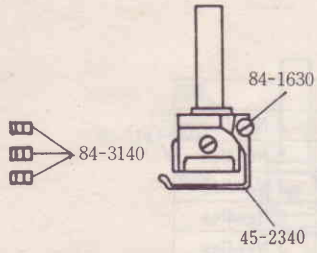

	m/m	Part No.	
1/8"	3.17	12-8110-1	2 Needles
5/32"	3.97	12-8120-1	
3/16"	4.76	12-8130-1	
7/32"	5.56	12-8140-1	
1/4"	6.35	12-8150-1	
※ 7/32"	5.56	12-8010-1	3 Needles
※ 1/4"	6.35	12-8020-1	

Needle holder (2,3 Needles)

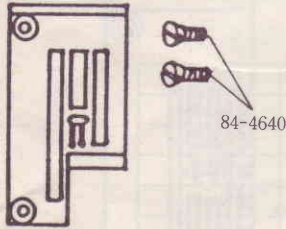

	m/m	Part No.	
1/8"	3.17	14-7260	2 Needles
5/32"	3.97	14-7360	
3/16"	4.76	14-7460	
7/32"	5.56	14-7560	
1/4"	6.35	14-7660	
※ 7/32"	5.56	14-8560	3 Needles
※ 1/4"	6.35	14-8660	

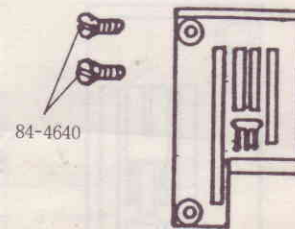

Needle plate (2 Needles)

Needle plate (3 Needles)

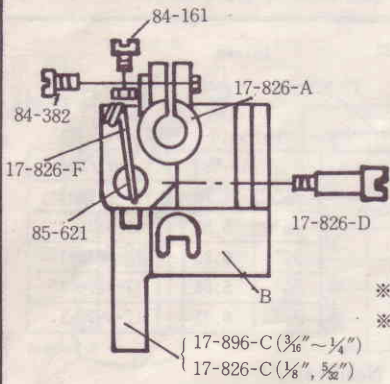

	m/m	Part No.	
1/8"	3.17	17-8260-1	2 Needles
5/32"	3.97	17-8360-1	
3/16"	4.76	17-8460-1	
7/32"	5.56	17-8560-1	
1/4"	6.35	17-8660-1	
※ 7/32"	5.56	17-8860-1	3 Needles
※ 1/4"	6.35	17-8960-1	

Presser foot (2 Needles)

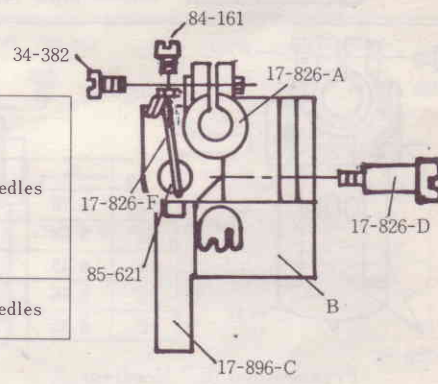

Presser foot (3 Needles)

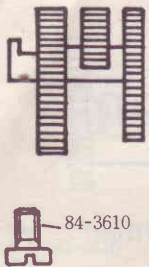

	m/m	Part No.
1/8"	3.17	15-9100
5/32"	3.97	15-9100
3/16"	4.76	15-9040
7/32"	5.56	15-9040
1/4"	6.35	15-9040

Feed dog(Rear)

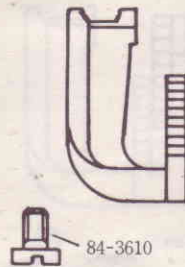

	m/m	Part No.
1/8"	3.17	15-9110
5/32"	3.97	15-9110
3/16"	4.76	15-9080
7/32"	5.56	15-9080
1/4"	6.35	15-9080

Feed dog(Front)

18-9020

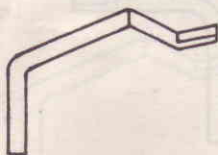

Needle guard

19-8010



Looper

18-1020

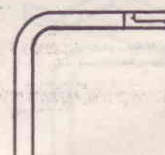

Needle guide

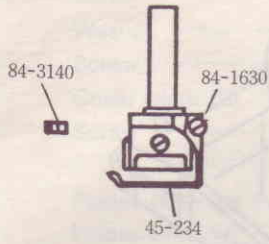

Needle holder **12-0150-1**

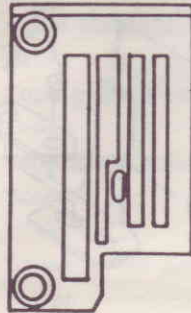

Needle plate **14-9610**

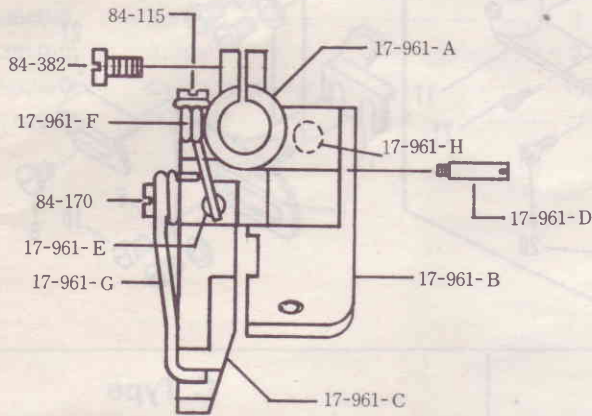

Presser foot **17-9610-1**

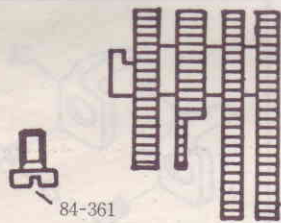

Feed dog(Rear) **15-9610**



Feed dog(front) **15-9620**

18-9020

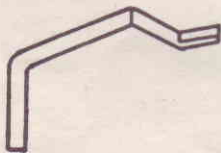

Needle guard

19-8010



Looper

18-1020

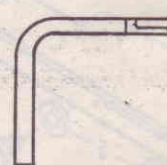

Needle guide

16. Attachments (アタッチメント)

F Type

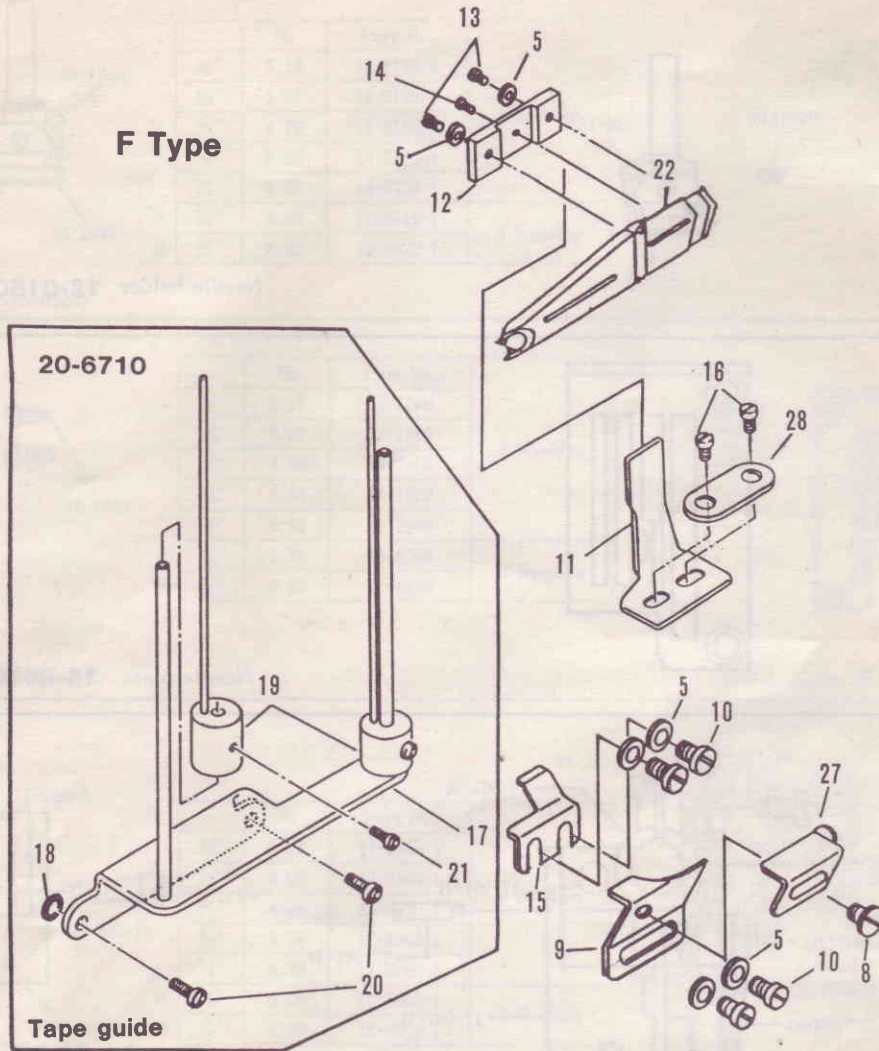

A Type

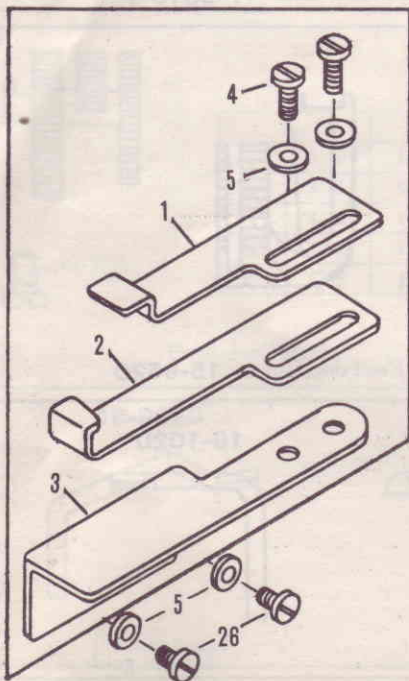

C Type

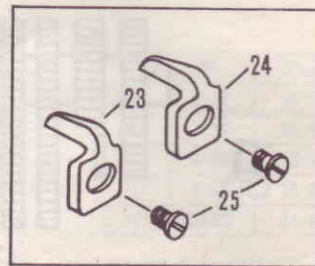

No.	Part No.	Part Name	品名	A	C	F
1	26-9040-0	Right guide (Atype)	A用ガイド (右)	1		
2	26-9050-0	Left guide	A用ガイド (左)	1		
3	26-9080-0	Guide mount plate	ガイド取付プレート	1		
4	84-5660-0	Screw	ネジ	2		
5	75-4550-0	Washer	ワッシャ	4		6
8	84-3700-0	Screw	ネジ			1
9	21-9250-0	Cover plate (B)	補助板 (B)			1
10	84-5750-0	Screw	ネジ			4
11	26-7250-0	Folder base for F	F用ラッパ取付台			1
12	26-7240-0	Folder bracket	F用ラッパ抱き			1
13	84-5720-0	Screw	ネジ			2
14	84-5710-0	Screw	ネジ			1
15	21-9240-0	Cover plate (A)	補助板 (A)			1
16	85-1820-0	Screw	ネジ			2
17	26-7020-0	Tape guide bracket	テープガイドブラケット			1
18	23-1870-0	O-ring	Oリング			2
19	26-7000-0	Tape guide adjuster	テープガイドアジャスター			2
20	84-5660-0	Screw	ネジ			2
21	84-5710-0	Screw	ネジ			2
22	97-7101-2	Folder	ホルダー (12mm仕上げ)			1
23	26-9120-0	Left side guide (C type)	かぶせ縫用ガイド (左)		1	
24	26-9110-0	Light side guide (C type)	かぶせ縫用ガイド (右)		1	
25	84-3640-0	Screw	ネジ		2	
26	84-3610-0	Screw	ネジ	2		
27	21-9320-0	Guide plate for F	F用前定規			1
28	26-7120-0	Plate	プレート			1

17. Thread stands Accessories (糸立て・アクセサリー)

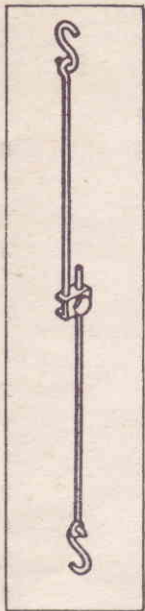

77-0060-2

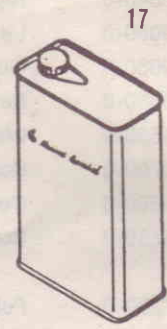
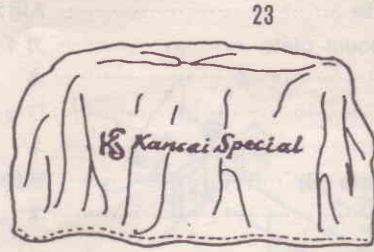
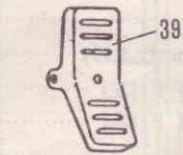
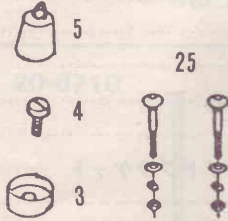
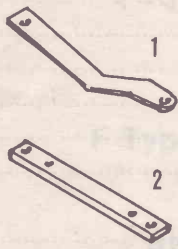

20-0020-0

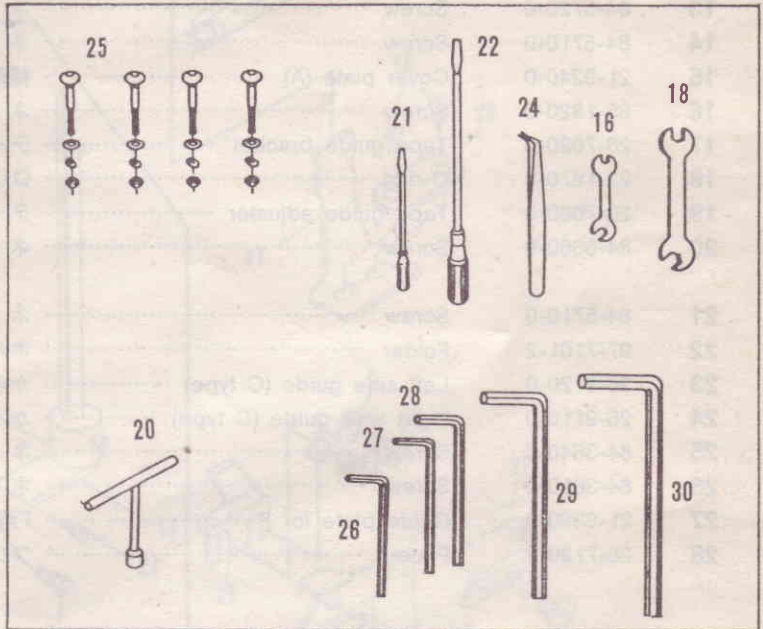

CS-2 R9201

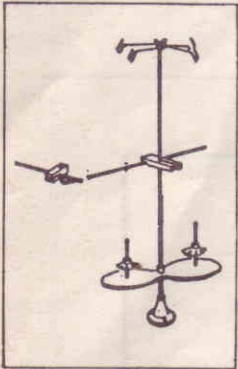

38

CS-4 R9202 R9203

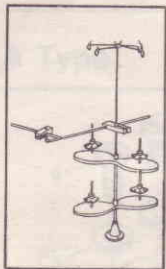

32

CS-5 R9302 R9303

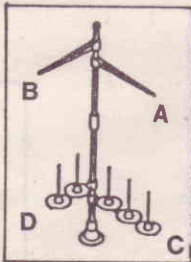

33

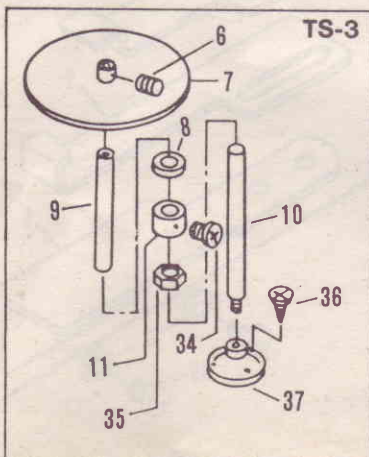
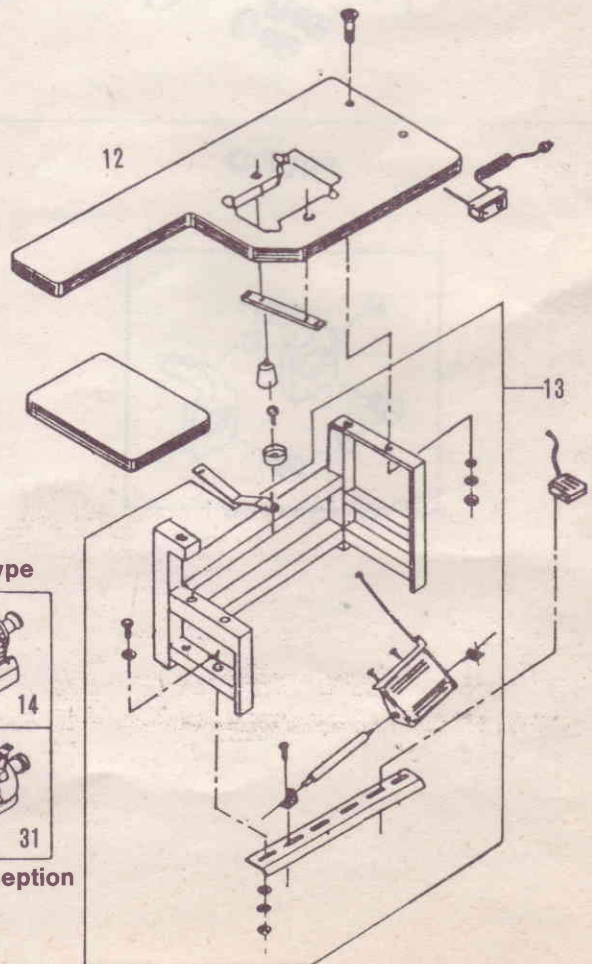

20-6130 F Type

UTC Type



UTC Exception

35

No.	Part No.	Part Name	品 名	Q, ty
1	25-1450-0	Mounting bracket (left)	タンク取付金具 (左)	1
2	25-1440-0	Mounting bracket (right)	タンク取付金具 (右)	1
3	25-4030-0	Cushion rubber base	クッションゴム受け	4
4	84-7630-0	Screw	ネ ジ	4
5	31-1620-0	Cushion rubber	クッションゴム	4
6	87-1500-0	Screw	ネ ジ	1
7	26-8580-0	φ200 tape reel disc	φ200円板テープガイド	1
8	26-8610-0	Cushion	円板クッションマット	1
9	26-8590-0	Guide pipe	ガイドパイプ	1
10	26-8570-0	Post B	テープ支柱B	1
11	26-8600-0	Stop collar	円板受けカラー	1
12	21-0900-0	Table top	天板	1
13	28-8050-0	Table stand	テーブルスタンド	1
14	06-9010-0	Moter	モーター	1
15	31-2220-0	Oil filter	オイルフィルター	1
16	28-4210-0	Spanner (small)	スパナ (小)	1
17	28-6110-0	Oil	オイル	1
18	28-4220-0	Spanner (large)	スパナ (大)	1
19	13-0110-6	Needles UY-128GAS #11	針	12
20	28-4640-0	T-handle socket wrench (3/8")	Tボックス	1
21	28-4510-0	Screw driver (small)	ドライバー (小)	1
22	28-4520-0	Screw driver (large)	ドライバー (大)	1
23	28-0210-0	Machine cover	マシンカバー	1
24	28-0110-0	Tweezers	ピンセット	1
25	80-7510-0	Bolt set	ボルトセット	6
26	28-3100-0	Hex key wrench	レンチ	1
27	28-3110-0	Hex key wrench A	レンチA	1
28	28-3120-0	Hex key wrench B	レンチB	1
29	28-3130-0	Hex key wrench C	レンチC	1
30	28-3140-0	Hex key wrench D	レンチD	1
31	59-2110-1	Cluth motor	クラッチモーター	1
32	42-0040-0	Thread stands (CS-4)	糸立て (CS-4) R9200専用	1
33	42-0050-0	Thread stands (CS-5)	糸立て (CS-5) R9300専用	1
34	87-1490-0	Screw	ネ ジ	1
35	88-1560-0	Nut	ナット	1
36	87-9010-0	Screw	ネ ジ	3
37	26-8560-0	Base B	テープ土台B	1
38	42-0020-0	Thread stands (CS-2)	糸立て (CS-2)	1
39	77-0010-2	Pedal	押え揚げペダル	1

18. Table diagram (テーブル図)

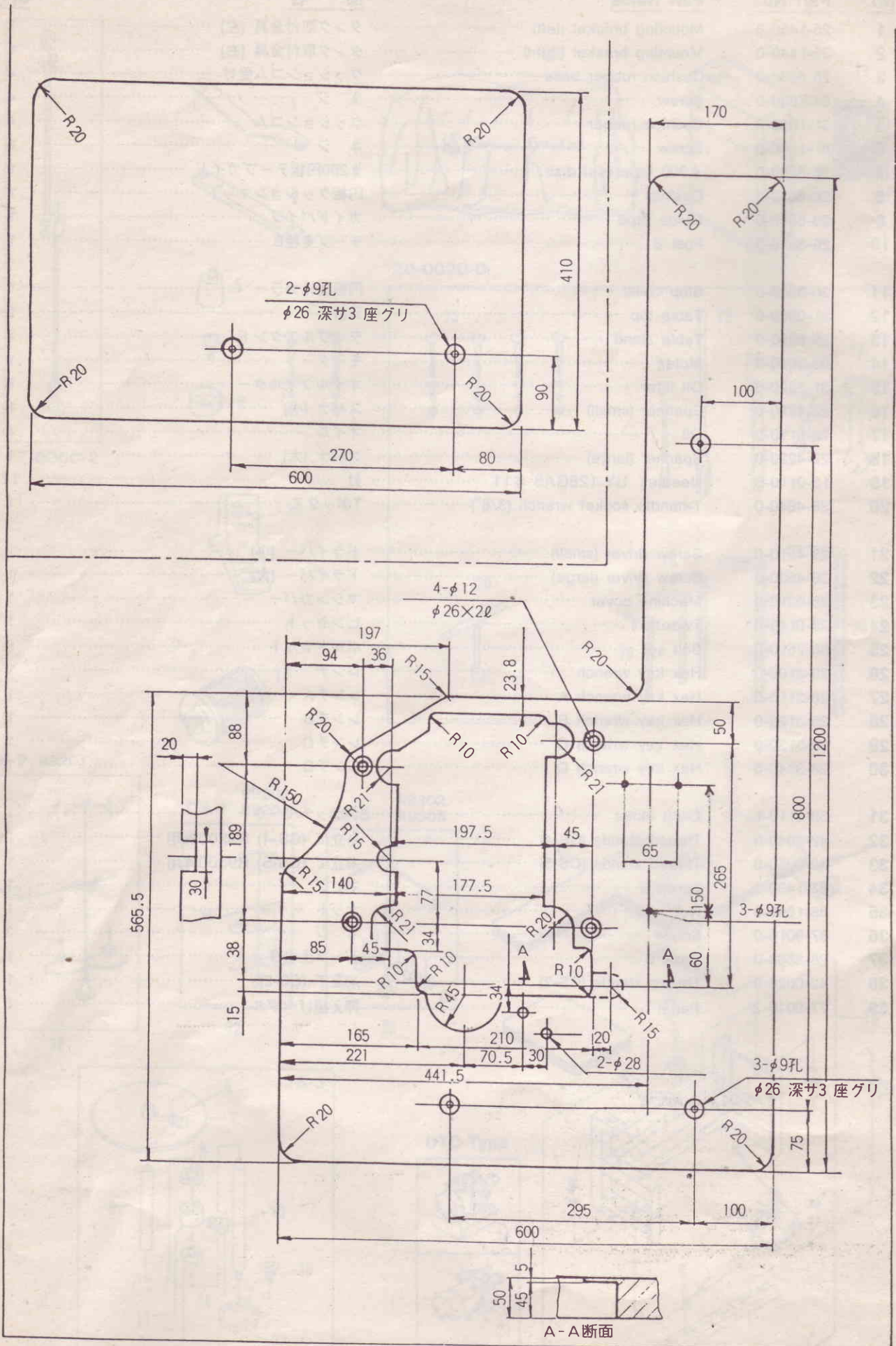

19. Index (索引)

Part No.	Q,ty	Page No.	Part No.	Q,ty	Page No.	Part No.	Q,ty	Page No.	Part No.	Q,ty	Page No.
00-4800-2		18	06-6110-0	1	26	11-8040-0	1	17	17-7640-1		29
-6000-4		25	-6120-0	1	26				-7670-1		30
-6000-5		21	-6130-0	1	26	12-0150-1		32	-7840-1		29
-6010-9		25	-6160-0	1	26	-8010-1		29	-7870-1		30
-6260-0		23	-6170-0	1	26	-8010-1		30	-7940-1		29
-6608-0		25	-6180-0	1	26	-8010-1		31	-7970-1		30
-6900-0		25	-6190-0	1	26	-8020-1		29	-8200-A		29
04-3490-0	1	26	-6200-0	1	26	-8020-1		30	-8200-A		30
-8020-0	1	18	-6220-0	1	20	-8020-1		31	-8200-C		29
-8020-1		18	-6220-0	1	26	-8110-1		29	-8200-C		30
-8030-0	1	18	-6230-0	1	20	-8110-1		31	-8200-D		29
-8030-1		18	-6230-0	1	26	-8120-1		29	-8200-D		30
06-0170-0	1	8	-6260-0	1	26	-8120-1		31	-8200-F		29
-0210-0	1	24	-6300-0	1	26	-8130-1		29	-8200-F		30
-0220-0	1	24	-6320-0	1	26	-8130-1		30	-8240-1		29
-0250-0	1	24	-6330-0	1	22	-8130-1		31	-8260-1		31
-0670-0	1	8	-6370-0	1	24	-8140-1		29	-8260-A		31
-0670-0	3	8	-6390-0	1	24	-8140-1		30	-8260-C		31
-0670-0	5	8	-6430-0	1	24	-8140-1		31	-8260-D		31
-0710-0	3	8	-6440-0	1	24	-8150-1		29	-8260-F		31
-0710-0	5	8	-6450-0	1	24	-8150-1		30	-8340-1		29
-0870-0	1	24	-6480-0	1	24	-8150-1		31	-8360-1		31
-0890-0	1	24	-6490-0	1	24				-8440-1		29
-0900-0	1	24	-6500-0	1	24	13-0110-6	12	36	-8460-1		31
-0980-0	1	24	-6520-0	1	24				-8470-1		30
-0990-0	1	24	-6530-0	1	24	14-7240-0		29	-8540-1		29
-1600-0	1	26	-6710-0	1	22	-7260-0		31	-8560-1		31
-2960-0	2	28	-6730-0	1	22	-7340-0		29	-8570-1		30
-3010-0	1	22	-6740-0	1	22	-7360-0		31	-8640-1		29
-3010-0	1	24	-6750-0	1	22	-7440-0		29	-8660-1		31
-3060-0	1	28	-6760-0	1	22	-7460-0		31	-8670-1		30
-3150-0	1	28	-6770-0	1	22	-7540-0		29	-8840-1		29
-3160-0	5	28	-6770-0	1	24	-7560-0		31	-8860-1		31
-3170-0	1	28	-6780-0	1	22	-7640-0		29	-8870-1		30
-3180-0	2	28	-6790-0	1	22	-7660-0		31	-8940-1		29
-5010-0	1	28	-6800-0	1	22	-8500-0		30	-8960-1		31
-5010-2		27	-6810-0	1	22	-8510-0		30	-8960-C		31
-5030-0	1	28	-6820-0	2	22	-8520-0		30	-8970-1		30
-5030-2		27	-6830-0	1	22	-8530-0		30	-9610-1		32
-5040-0	1	28	-6840-0	1	22	-8540-0		29	-9610-A		32
-5040-2		27	-6890-0	1	22	-8560-0		31	-9610-B		32
-5060-0	1	28	-7240-0		27	-8630-0		30	-9610-C		32
-5120-0	1	28	-7510-0	2	22	-8640-0		29	-9610-D		32
-5150-0	2	28	-8480-0	1	26	-8660-0		31	-9610-E		32
-5160-0	1	28	-9010-0	1	36	-9100-2	1	2	-9610-F		32
-5170-0	1	28	-9350-0	4	22	-9610-0		32	-9610-G		32
-5170-2		27	-9350-0	4	24				-9610-H		32
-5190-0	3	28	-9440-0	2	8	15-9020-0		30			
-5210-0	1	28	-9440-0	3	8	-9030-0		29	18-1020-0	1	16
-5230-0	1	28	-9440-0	4	8	-9040-0		31	-1020-0		29
-5350-0	1	28	-9440-0	5	8	-9070-0		29	-1020-0		30
-5500-0	1	28	-948B-0	1	8	-9070-0		30	-1020-0		31
-5510-1	1	28	-9510-0	1	26	-9080-0		31	-1020-0		32
-5520-0	1	28	-9520-0	1	26	-9100-0		31	-9000-0	2	16
-5640-0	4	28	-9530-0	1	26	-9110-0		31	-9010-0	1	16
-5650-0	4	28	-9540-0	1	26	-9140-0		29	-9020-0	1	16
-5720-0	4	28	-9550-0	1	26	-9150-0		29	-9020-0		29
-6010-0	2	26	-9560-0	1	26	-9610-0		32	-9020-0		30
-6020-0	1	26	-9570-0	1	2	-9620-0		32	-9020-0		31
-6030-0	1	26	-9580-0	1	12				-9020-0		32
-6040-0	1	26	-9620-0	1	26	17-7240-1		29			
-6050-0	1	26	-9780-0	1	28	-7340-1		29	19-8010-0		29
-6060-0	1	26	09-9400-0	1	28	-7440-1		29	-8010-0		30
-6080-0	1	26	10-9340-1	15		-7470-1		30	-8010-0		31
						-7540-1		29	-8010-0		32
						-7570-1		30	-8080-0	1	18

Part No.	Q,ty	Page No.	Part No.	Q,ty	Page No.	Part No.	Q,ty	Page No.	Part No.	Q,ty	Page No.
19-9000-0	1	16	23-9060-0	1	10	33-8020-0	4	8	41-107W-0	3	8
-9020-0	1	16	-9070-0	1	2	-8020-0	5	8	-107W-0	3	8
			-9070-0	1	10				-107W-0	4	8
20-0020-0		35	-9080-0	1	2	35-1070-0	1	10	-107W-0	4	8
-1907-W		1	-9090-0	1	2	-1610-0	1	10	-107W-0	5	8
-1923-W		1	-9110-0	5	10	-2070-0	1	10	-107W-0	5	8
-212W-0		1	-9130-0	1	10	-3140-0	1	10	-1110-0	4	8
-532G-0	1	6	-9140-0	1	2	-3150-0	1	10	-1110-0	4	8
-6130-0		35	-9220-0	1	2	-3180-0	1	10	-1110-0	6	8
-6710-0		33				-3240-0	2	10	-1110-0	6	8
			25-1440-0	1	36	-3420-0	1	10	-1110-0	8	8
21-0900-0	1	36	-1450-0	1	36	-4030-0	1	10	-1110-0	8	8
-140W-0	1	24	-4030-0	4	36	-4120-0	9	10	-1110-0	10	8
-212W-0	1	2	-9030-0	1	2	-8220-0	1	10	-1110-0	10	8
-4020-0	1	2	-9040-0	1	2	-8290-0	1	10	-1150-0	2	8
-7030-0	1	6	-9050-0	1	2	-8310-0	1	10	-1150-0	2	8
-7120-0	1	6				-8320-0	1	10	-1150-0	3	8
-805W-0	1	2	26-7000-0	2	34	-8390-0	1	10	-1150-0	3	8
-806W-0	1	24	-7020-0	1	34	-9000-0	1	10	-1150-0	4	8
-900W-0	1	2	-7120-0	1	34	-9020-0	1	10	-1150-0	4	8
-906W-0	1	2	-7240-0	1	34	-9040-0	1	10	-1150-0	5	8
-907W-0	1	2	-7250-0	1	34	-9070-0	1	10	-1150-0	5	8
-914W-0	1	2	-8560-0	1	36	-9110-0	1	10	-1150-0	6	8
-9220-0	1	2	-8570-0	1	36	-9120-0	1	10	-1150-0	6	8
-9240-0	1	34	-8580-0	1	36	-9140-0	1	10	-1170-0	2	8
-9250-0	1	34	-8590-0	1	36	-9150-0	1	10	-1170-0	2	8
-9320-0	1	34	-8600-0	1	36				-1170-0	3	8
-9330-0	1	2	-8610-0	1	36	39-1370-0	1	2	-1170-0	3	8
-936W-0	1	2	-9040-0	1	34	-1380-0	1	10	-1170-0	4	8
-938G-0	1	2	-9050-0	1	34	-1390-0	1	10	-1170-0	4	8
-942W-0	1	2	-9080-0	1	34	-2160-0	1	2	-1170-0	5	8
-9450-0	1	6	-9110-0	1	34	-2330-0	1	2	-1170-0	5	8
-946W-0	1	2	-9120-0	1	34	-8010-0	1	4	-1170-0	6	8
-947W-0	1	2				-8030-0	1	10	-1170-0	6	8
-948W-0	1	2	27-5310-0	1	6	-8060-0	1	10	-1310-0	2	8
-949G-0	1	2	-5330-0	1	6				-1310-0	3	8
-950W-0	1	2	-5340-0	1	6	40-0900-0		7	-1310-0	4	8
-9540-0	1	2				-0930-0		7	-1310-0	5	8
			28-0110-0	1	36	-0940-0		7	-1320-0	1	8
23-1530-0	1	2	-0210-0	1	36	-0950-0		7	-1320-0	2	8
-1600-0	1	10	-3100-0	1	36	-717W-0		7	-1510-0	1	6
-1640-0	2	10	-3110-0	1	36	-718W-0		7	-1510-2		5
-1680-0	1	2	-3120-0	1	36	-8030-0		5	-1530-0	1	6
-1750-0	1	2	-3130-0	1	36	-811B-0		7	-1540-0	1	6
-1830-0	1	14	-3140-0	1	36	-821B-0		7	-1550-0	2	6
-1870-0	2	34	-4210-0	1	36	-822B-0		7	-1560-0	2	6
-1900-0	1	28	-4220-0	1	36	-831B-0		7	-1570-0	1	6
-2390-0	1	2	-4510-0	1	36	-832B-0		7	-1720-0	2	8
-3040-0	1	10	-4520-0	1	36	-9100-0		5	-1720-0	3	8
-3060-0	3	10	-4640-0	1	36	-911B-0		7	-1720-0	4	8
-3110-0	1	20	-6110-0	1	36	-921B-0		7	-1720-0	5	8
-3240-0	2	8	-8050-0	1	36	-922B-0		7	-1750-0	2	8
-3240-0	2	8				-931B-0		7	-1750-0	3	8
-3240-0	3	8	30-0200-0		9	-932B-0		7	-1750-0	4	8
-3240-0	3	8	-8290-0		9				-1750-0	5	8
-3240-0	4	8	-8390-0		9	41-101W-0	2	8	-236B-0	1	8
-3240-0	4	8	-9000-0		9	-101W-0	2	8	-237B-0	1	8
-3240-0	5	8	-9110-0		9	-101W-0	3	8	-3040-1	1	6
-3240-0	5	8	-9420-0		9	-101W-0	3	8	-7010-0	1	8
-3410-0	1	10				-101W-0	4	8	-7010-0	1	8
-3410-0	1	14	31-1620-0	4	36	-101W-0	4	8	-7010-0	2	8
-3410-0	1	16	-1950-0	1	10	-101W-0	5	8	-7010-0	2	8
-3410-0	1	16	-1950-2		9	-101W-0	5	8	-7010-0	3	8
-3410-0	1	18	-2220-0	1	10	-105W-0	2	8	-7010-0	3	8
-3410-0	3	14	-2220-0	1	36	-105W-0	2	8	-7020-0	1	8
-3430-0	1	10	-3140-0	2	10	-105W-0	3	8	-7020-0	1	8
-4160-0	1	14	-3140-0	2	10	-105W-0	3	8	-7020-0	2	8
-4270-0	1	2	-4090-0	1	10	-105W-0	4	8	-7020-0	2	8
-8000-0	1	4	-4150-0	1	12	-105W-0	4	8	-7220-0	1	6
-8030-0	1	2	-4190-0	1	10	-105W-0	5	8	-7260-0	1	8
-9000-0	2	14				-105W-0	5	8	-7270-0	1	8
-9040-0	1	2	33-8020-0	2	8	-107W-0	2	8	-7280-0	1	8
-9050-0	1	10	-8020-0	3	8	-107W-0	2	8	-729B-0	1	8

Part No.	Q.ty	Page No.	Part No.	Q.ty	Page No.	Part No.	Q.ty	Page No.	Part No.	Q.ty	Page No.
41-7300-0	1	8	61-5140-0	1	12	71-9450-0	1	14	77-1010-0	1	20
			-7130-U	1	12	-9470-0	1	14	-1030-0	1	20
42-0020-0	1	36	-8010-U	1	18				-1110-0	1	20
-0040-0	1	36	-8020-U	1	18	73-1130-1	1	24	-1210-0	1	20
-0050-0	1	36	-9040-U	1	16				-1390-0	2	20
			-9050-0	1	16	75-0970-0	2	22	-8010-0	1	20
43-3380-0	1	6	-9060-0	1	14	-1060-1	2	17	-8020-0	1	20
-9040-0	2	6			-1060-1	1	17	-8030-1	1	20	
-9170-0	1	6	63-1030-1	1	16	-1070-0	1	12	-8040-0	1	20
-9200-0	1	6	-5250-1	1	16	-1070-1	1	11	-8060-1	1	20
-9220-0	1	6	-8110-1	1	16	-1120-1	1	12	-8070-1	1	20
-9240-0	1	6	-9030-0	1	14	-1220-0	1	20	-8080-0	1	20
-9250-0	1	6	-9050-0	1	14	-1220-0	1	26	-8140-0	1	20
-9260-0	1	6			-1300-1	1	20	-8150-0	1	20	
			65-3200-0	1	16	-1450-1	2	20	-8880-0	1	20
45-0910-0	1	6			-1520-0	1	18	-8890-0	1	20	
-0940-0	1	6	66-1020-0	1	24	-1520-1	1	17			
-0960-0	1	6	-8010-0	1	17	-1520-1	1	18	79-0420-0	1	20
-1420-0	1	6	-8020-0	1	17	-1600-0	1	12	-0600-0	4	12
-1690-0	1	6			-1800-0	1	18	-1140-0	1	26	
-1810-0	1	17	67-1000-0	1	16	-1830-0	1	12	-1230-0	1	20
-2340-0	29		-8010-0	1	17	-1870-0	1	14	-1290-0	1	26
-2340-0	30		-8020-0	1	12	-1880-1	1	14	-1640-0	1	8
-2340-0	31		-8030-1	1	17	-2480-0	1	17	-2270-0	1	20
-2340-0	32		-8030-1	1	17	-2490-0	2	17	-2280-0	1	6
-2460-0	1	6	-8040-0	1	18	-3060-0	2	17	-4030-0	1	14
-2510-0	1	6	-8040-1	1	18	-3220-0	1	12	-5160-0	1	14
-9140-0	1	6	-8050-0	1	17	-3320-0	2	12	-7030-0	1	22
-9250-0	1	6	-8050-0	1	17	-3560-0	1	18	-7030-0	1	24
			-9090-0	1	16	-3560-0	2	17	-9140-0	1	8
47-1440-0	1	6	-9100-0	1	14	-3720-0	1	16	-9220-0	2	2
-1490-0	1	6			-3810-0	1	17	-9230-0	1	2	
			69-1470-0	2	12	-3820-0	2	14			
			-1520-0	1	12	-3830-0	1	16	80-5800-0		19
49-1440-1	1	12	-1530-0	1	12	-3850-0	2	16	-7510-0	6	36
			-222G-0	1	12	-3870-0	1	12	-7520-0	4	28
50-1950-0		13	-3110-0	1	12	-3880-0	2	12			
-1960-0		13	-4160-0	1	14	-3980-0	1	18	81-0810-0	1	4
			-4200-0	1	14	-4010-0	1	16	-0820-0	2	4
51-9020-0	1	14	-7020-0	1	14	-4100-0	1	14	-1490-0	1	4
-9040-0	1	14	-8010-0	1	17	-4140-0	1	14	-1620-0	1	4
-9060-0	1	14	-8030-0	1	4	-4360-0	1	20	-1630-0	1	4
-9110-0	1	14			-4510-0	1	20	-2060-0	1	4	
-9130-0	1	14	70-0930-0		11	-4520-0	1	2	-2090-0	1	4
-9140-0	1	14	-1010-0		19	-4520-0	1	14	-2360-0	1	4
-9150-0	1	14	-7800-0		19	-4520-0	2	6	-2370-0	1	4
			-7810-0		19	-4520-0	6	10	-4030-0	1	16
59-2110-1	1	36				-4530-0	1	26	-7520-0	1	4
			71-1160-0	1	2	-4550-0	2	2	-7530-0	1	4
60-0650-0	1	16	-1610-0	1	24	-4550-0	2	6	-7540-0	4	4
-0650-0		15	-1620-0	1	24	-4550-0	3	2	-8030-0	1	4
-1520-0		15	-2020-0	2	6	-4550-0	3	6	-8080-0	1	4
-222G-0		11	-2160-0	2	4	-4550-0	4	8	-9030-0	1	4
-3390-0	1	12	-2520-0	2	2	-4550-0	4	34	-9040-0	1	4
-3390-0		11	-3260-0	1	20	-4550-0	6	24	-9090-0	1	4
-3910-0		15	-4310-0	1	16	-4550-0	6	34	-9090-0	1	12
-3930-0		18	-4340-0	1	14	-4550-0	7	24			
-3980-0		15	-4340-0	1	14	-4670-0	2	24	84-1030-0	1	26
-7100-0		15	-4550-0	1	12	-4680-0	1	22	-1040-0	1	26
-8010-5		17	-4550-0	1	17	-4700-0	1	10	-1120-0	1	6
-8030-0		17	-4550-0	1	18	-4700-0	1	10	-1150-0		32
-9000-0	1	12	-5010-0	2	17	-5220-0	2	17	-1610-0	1	2
-9000-0		11	-5060-0	1	12	-5220-0	4	17	-1610-0	1	22
-9030-0		13	-5430-0	1	20	-5520-0	1	12	-1610-0	2	6
-9060-0		13	-5530-0	1	18	-5520-0	1	18	-1610-0	2	26
-9060-5		13	-5540-0	1	20	-8140-0	2	12	-1610-0	6	26
-9100-0		13	-6930-0	1	17	-9410-0	1	8	-1610-0		29
-9300-0		11	-9170-0	1	16	-9420-0	2	8	-1610-0		31
			-9200-0	1	12	-9430-0	2	8	-1620-0	2	24
61-1010-0	1	16	-9290-0	1	12				-1630-0	5	6
-3140-0	1	14	-9300-0	1	12				-1630-0		29
-3290-0	1	14	-9340-0	1	16	77-0010-2	1	36	-1630-0		30
-3300-0	1	14	-9350-0	1	16	-0060-2		35	-1630-0		31
-5130-U	1	16									

Part No.	Q,ty	Page No.	Part No.	Q,ty	Page No.	Part No.	Q,ty	Page No.	Part No.	Q,ty	Page No.
84-1630-0		32	84-5210-0	2	16	84-7180-0	1	16	87-1380-0	1	22
-1700-0		32	-5210-0	2	16	-7180-0	1	16	-1390-0	2	14
-1710-0	1	6	-5210-0	2	20	-7180-0	1	20	-1490-0	1	36
-1710-0	1	6	-5210-0	2	24	-7180-0	2	12	-1500-0	1	36
-1710-0	1	24	-5590-0	2	8	-7180-0	2	12	-1700-0	1	14
-1720-0	2	16	-5610-0	1	20	-7180-0	2	14	-1710-0	1	14
-1720-0	4	18	-5620-0	1	20	-7190-0	1	12	-1730-0	2	26
-2020-0	1	26	-5630-0	1	12	-7260-0	1	18	-1730-0	3	26
-3140-0	1	22	-5630-0	3	12	-7610-0	1	12	-1830-0	1	10
-3140-0	2	2	-5640-0	1	6	-7610-0	4	10	-1880-0	1	28
-3140-0	2	24	-5640-0	2	6	-7630-0	2	4	-1880-0	5	10
-3140-0	6	8	-5640-0	4	10	-7630-0	3	2	-2090-0	1	28
-3140-0	7	8	-5640-0	4	24	-7630-0	4	36	-2630-0	1	12
-3140-0	11	8	-5640-0	5	24	-7650-0	2	8	-3110-0	1	10
-3140-0		29	-5640-0	7	22	-7820-0	1	8	-9010-0	3	36
-3140-0		30	-5660-0	1	10	-8120-0	1	20			
-3140-0		31	-5660-0	1	14	-8120-0	1	20	88-1460-0	2	22
-3140-0		32	-5660-0	1	24	-8120-0	1	26	-1460-0	2	24
-3610-0	1	10	-5660-0	2	26	-8120-0	2	20	-1560-0	1	36
-3610-0	1	17	-5660-0	2	26	-8140-0	1	14	-1570-0	1	26
-3610-0	2	6	-5660-0	2	34	-8140-0	1	14	-1580-0	1	26
-3610-0	2	8	-5660-0	2	34	-8140-0	1	17	-1660-0	1	2
-3610-0	2	10	-5660-0	3	2	-8140-0	1	17	-1660-0	2	26
-3610-0	2	22	-5660-0	3	12	-8140-0	1	20			
-3610-0	2	24	-5660-0	3	22	-8160-0	1	20	91-2720-0	1	14
-3610-0	2	26	-5660-0	3	24	-8160-0	2	16	-4060-0	1	14
-3610-0	2	34	-5660-0	4	26	-8170-0	1	16	-4060-0	1	16
-3610-0		29	-5660-0	5	2	-8170-0	1	20	-8960-0	1	12
-3610-0		30	-5660-0	7	26				-9020-0	1	12
-3610-0		31	-5660-0	10	2	85-1010-0	2	26	-9030-0	1	12
-3610-0		32	-5670-0	1	18	-1020-0	2	26	-9070-0	1	12
-3620-0	3	2	-5670-0	2	16	-1130-0	2	12			
-3630-0	1	18	-5670-0	4	20	-1130-0	2	14	93-2000-0	1	20
-3640-0	2	22	-5680-0	1	2	-1130-0	2	17	-2050-0	1	14
-3640-0	2	34	-5710-0	1	34	-1130-0	2	20	-2110-0	1	16
-3650-0	4	24	-5710-0	2	6	-1140-0	2	12	-2110-0	1	26
-3660-0	1	14	-5710-0	2	10	-1820-0	2	34	-2230-0	1	10
-3660-0	1	16	-5710-0	2	34	-2090-0	1	2	-4060-0	1	14
-3660-0	4	24	-5710-0	3	2	-2100-0	1	16	-4060-0	1	16
-3700-0	1	34	-5710-0	3	6	-2120-0	1	12	-6110-0	2	20
-3700-0	4	2	-5710-0	4	24	-2120-0	1	20			
-3740-0	1	6	-5720-0	2	10	-2130-0	1	17	94-2140-0	2	4
-3740-0	2	8	-5720-0	2	12	-6070-0	1	24	-2310-0	2	4
-3790-0	2	2	-5720-0	2	34	-6110-0	2	24	-8010-0	1	4
-3790-0	2	14	-5740-0	1	6	-6200-0	2	26	-8010-0	1	18
-3790-0	2	16	-5740-0	2	10	-6210-0		31	-8020-0	2	4
-3820-0		29	-5740-0	2	14	-6230-0		30	-8100-0	1	12
-3820-0		30	-5750-0	1	2	-6250-0	2	26			
-3820-0		31	-5750-0	1	24	-8010-0	1	20	97-7101-2	1	34
-3820-0		32	-5750-0	4	34						
-4010-0	1	16	-5790-0	4	12	86-2110-0	3	24	98-2160-0	2	16
-4010-0	2	17	-5990-0	1	17	-3110-0	1	14	-6140-0	1	12
-4130-0	1	6	-6080-0	1	26	-3110-0	1	22			
-4130-0	1	18	-6110-0	1	16	-3110-0	2	17			
-4130-0	1	24	-6110-0	1	18	-3120-0	2	26			
-4130-0	3	22	-6110-0	2	24	-3150-0	2	12			
-4620-0	2	10	-6110-0	2	24	-3160-0	1	14			
-4640-0		29	-6110-0	2	24	-4110-0	1	8			
-4640-0		30	-6120-0	1	16	-4110-0	1	16			
-4640-0		31	-6120-0	2	16	-4110-0	1	16			
-5110-0	2	17	-6160-0	1	14	-4110-0	2	8			
-5110-0	2	18	-6160-0	1	16	-4110-0	2	20			
-5110-0	2	20	-6160-0	1	20	-4110-0	3	8			
-5210-0	1	4	-6160-0	1	20	-4110-0	4	8			
-5210-0	1	10	-6170-0	1	17	-4120-0	1	16			
-5210-0	1	10	-6210-0	2	12	-5010-0	1	12			
-5210-0	1	14	-6250-0	3	24	-5010-0	1	17			
-5210-0	1	24	-6330-0	1	26	-5010-0	1	18			
-5210-0	2	6	-6340-0	1	2	-8510-0	1	20			
-5210-0	2	12	-6610-0	1	10						
-5210-0	2	12	-6610-0	4	2	87-1160-0	2	28			
-5210-0	2	14	-7060-0	1	22	-1350-0	2	14			
-5210-0	2	16	-7110-0	2	12	-1380-0	1	14			

 **MORIMOTO MFG. CO., LTD.**

MAIN FACTORY

180, Suna Shijohnawate-city, Osaka 575, Japan

Tel: (0720) 77-1221 Telex: 5349134 KSPCAL-J Fax: (0720) 78-9649

TOKYO OFFICE

5-16-7, Kohtobashi Sumida-ku, Tokyo 130, Japan

Tel: (03) 635-5121 Fax: (03) 635-5123

OKAYAMA OFFICE

Village Okuda 1F, 24-19, Okuda-Honmachi Okayama-city 700, Japan

Tel: (0862) 32-9120 Fax: (0862) 22-8292

KANSAI SPECIAL U.S.A. CORP.

640 Gotham Parkway Carlstadt N.J. 07072 U.S.A.

Tel: (201) 460-0350 Telex: 219449 (KSPCUR) Fax: (201) 460-1633

MORIMOTO MFG. (H.K.) LTD.

203-207 G/F, Lai Chi Kok Road, Sham Shui Po, Kowloon, Hong Kong

Tel: 3-918357-9 Telex: 31167 MORHK HX Fax: 3-7891707

MORIMOTO MFG. (H.K.) LTD. SINGAPORE REP. OFFICE

66 East Coast Road, #04-04 Grth Building Singapore 1542

Tel: 3457576 Telex: RS25138 A/B: MMSPL Fax: 3449603

KANSAI SPECIAL MI EUROPE G.M.B.H.

Wahler Strasse 37 4000 Düsseldorf, 30 W. GERMANY

Tel: 0211-658020 Telex: 8586555 KSWGD Fax: 0211-6581529