

**JUKI®**

**Feed-off-the-arm, 3-needle Double Chainstitch Machine**  
送り出し腕型3本針二重環縫いミシン

# MS-3580 Series

## PARTS LIST

**JUKI®**

**JUKI 株式会社**

〒206-8551 東京都多摩市鶴牧 2-11-1

縫製機器ユニット

TEL.042-357-2371(ダイヤルイン) FAX.042-357-2274

お問い合わせ、ご相談は  
To order or for further  
information,  
please contact:

**JUKI CORPORATION**

SEWING MACHINERY BUSINESS UNIT  
2-11-1, TSURUMAKI, TAMA-SHI,  
TOKYO, 206-8551, JAPAN  
PHONE:(81)42-357-2371  
FAX:(81)42-357-2274

Copyright© 2008-2014 JUKI CORPORATION  
本書の内容を無断で転載、複写することを  
禁止します。  
All rights reserved throughout the world.

※このパーツリストは商品改良のため予告なく変更する事があります。  
\*The description covered in this parts list is subject to change for improvement of the commodity without notice.  
※このパーツリストは 2014年 10月現在の商品仕様で編集したものです。  
\*This parts list is edited in accordance with the product specifications as of October 2014.

Printed in Japan

**40070364**  
**No.1506-06**

# CONTENTS

## 目次

1. FRAME MISCELLANEOUS & BEARING COMPONENTS .....	1
頭部外装・軸受け関係	
2. FRAME MISCELLANEOUS, BEARING & FOLDER COMPONENTS (FOR MS-3580SF/0SN) .....	3
頭部外装・軸受け・フォルダー関係 (MS - 3580 SF / 0 SN 用)	
3. FRAME MISCELLANEOUS, BEARING & FOLDER COMPONENTS (FOR MS-3580SF/1SN) .....	5
頭部外装・軸受け・フォルダー関係 (MS - 3580 SF / 1 SN 用)	
4. DETACHABLE HEAD COMPONENTS .....	7
ヘッド関係	
5. OIL LUBRICATION & NEEDLE DRIVING COMPONENTS .....	9
給油・針駆動関係	
6. FEED MECHANISM COMPONENTS (FOR MS-3580SF/0SN) .....	11
送り関係 (MS - 3580 SF / 0 SN 用)	
7. FEED MECHANISM COMPONENTS (FOR MS-3580SF/1SN) .....	13
送り関係 (MS - 3580 SF / 1 SN 用)	
8. LOOPER DRIVING COMPONENTS (FOR MS-3580SF/0SN) .....	15
ルーパー駆動関係 (MS - 3580 SF / 0 SN 用)	
9. LOOPER DRIVING COMPONENTS (FOR MS-3580SF/1SN) .....	17
ルーパー駆動関係 (MS - 3580 SF / 1 SN 用)	
10. UPPER ROLLER FEED & THREAD TENSION COMPONENTS .....	19
上ローラー送り・糸調子関係	
11. PULLEY, UPPER ROLLER FEED & DRIVING COMPONENTS .....	21
プーリー・上ローラー送り・駆動関係	
12. SEWING PARTS COMPONENTS .....	23
ゲージ関係	
13. THREAD STAND COMPONENTS .....	25
糸立て装置関係	
14. ACCESSORIES PARTS COMPONENTS .....	27
付属品関係	
15. LIST FOR INFORMATION OF CHANGE .....	29
変更情報リスト	
NUMERICAL INDEX OF PARTS .....	30
索引	

# 1. FRAME MISCELLANEOUS & BEARING COMPONENTS

頭部外装・軸受け関係

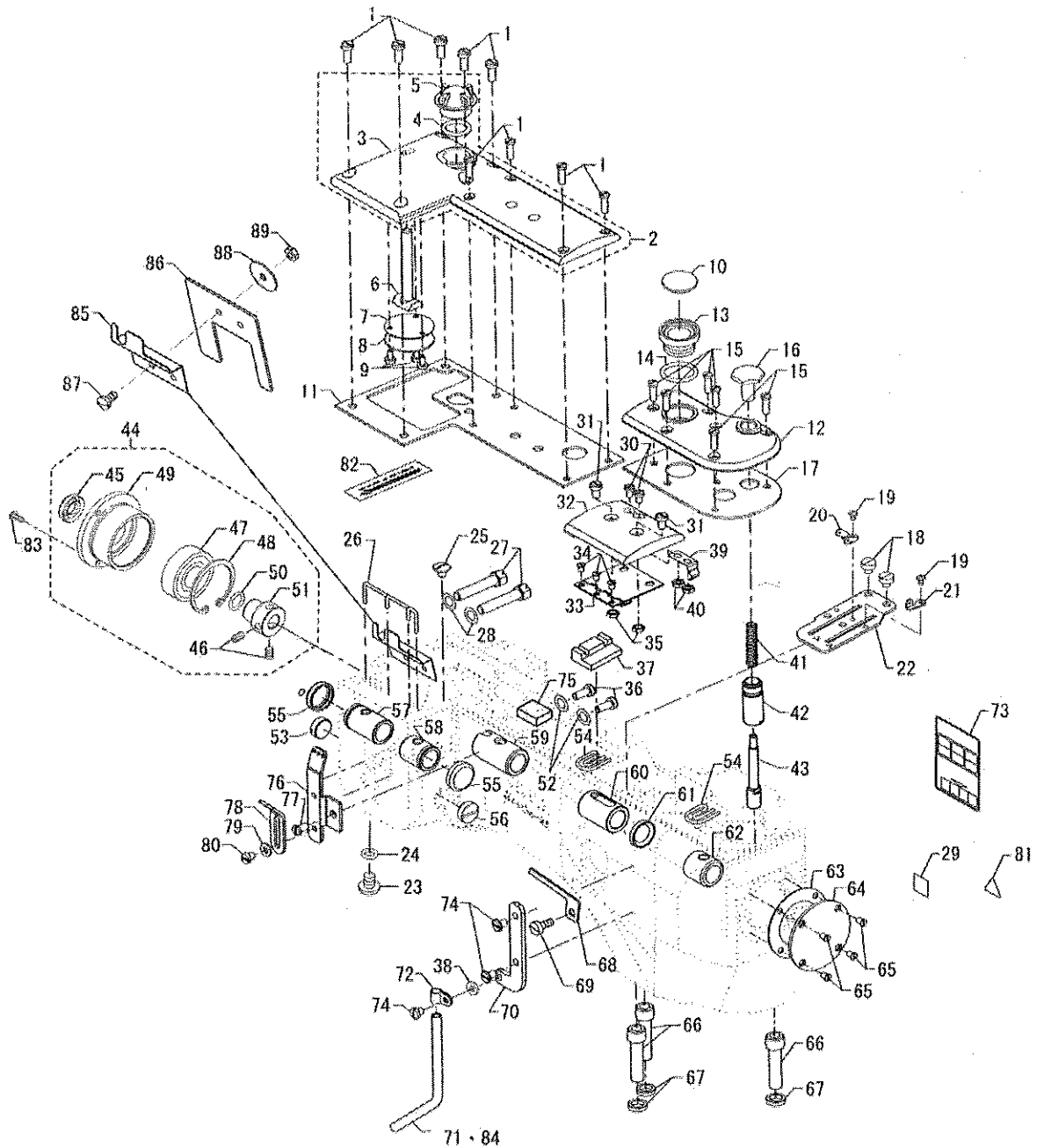

REF.NO	NOTE	PART NO	DESCRIPTION	品名	Qty
1		SS-4111215-SP	SCREW 11/64-40 L=12	なべねじ 11/64-40 L=12	9
2		400-66849	CHAMBER COVER ASSEMBLY	後トップカバー組	1
3		400-70102	TOP COVER REAR	後トップカバー	(1)
4		RO-1482402-00	RUBBER RING	Oリング	(1)
5		229-24708	OIL SIGHT WINDOW	オイル循環確認窓(後)	(1)
6		400-66851	PRESSER SPRING BAR	押えばね軸	1
7		400-66854	GASKET	カバーガスケット	1
8		400-66855	COVER PLATE	カバープレート	1
9		SM-5030655-SP	SCREW	バインドねじ M3 L=6	3
10		400-09014	OIL SIGHT WINDOW	オイル循環確認窓(前)	1
11		400-68335	GASKET	パッキン	1
12		400-66857	TOP COVER FRONT	前トップカバー	1
13		400-72348	SCREW	油窓固定ねじ	1
14		RO-1482402-00	RUBBER RING	Oリング	1
15		SM-4041255-SP	SCREW M4 L=12	なべねじ M4 L=12	6
16		400-66854	LOOPER THROW OUT PLUNGER KNOB	ルーバーブッシュボタン	1
17		400-68341	GASKET	パッキン	1
18		SM-6050800-SP	SCREW M5 L=8	平ねじ M5 L=8	2
19		SS-4080515-SP	SCREW 1/8-44 L=5	なべねじ 1/8-44 L=5	2
20		400-66865	CAST OFF PLATE EYELET	下糸案内板	1
21		400-66866	CAST OFF PLATE EYELET	下糸案内板	1
22		400-68345	CAST OFF PLATE	カム糸道台	1
23		131-71004	DRAIN SCREW	廃油ねじ	1
24		131-70105	RUBBER RING	Oリング	1
25		SM-6050660-TP	SCREW	平小ねじ M5 L=6	1
26		CQ-3030000-00	OIL WICK	油芯	0.15
27		SM-6063002-TP	SCREW M6 L=30	搬送体軸受止めねじ	2
28		WP-0651056-SD	WASHER 6.5X11X1	平座金 6.5 x 11 x 1	2
29		CM-8001001-01	WEEE MARK LABEL S	WEEEマークラベルS	1
30		SS-7090710-SP	SCREW 9/64-40 L=6.8	丸平ねじ 9/64-40 L=6.8	2
31		SS-6111010-TP	SCREW 11/64-40 L=9.5	平ねじ 11/64-40 L=9.5	2
32		400-70062	TOP COVER	中央トップカバー	1
33		400-66875	MIDDLE TOP COVER HINGE	カバー止め蝶番	1
34		SS-6090420-SP	SCREW 9/64-40 L=4.0	平ねじ 9/64-40 L=4	3
35		NS-6110350-SP	NUT 11/64-40	六角ナット 11/64-40	2
36		SS-7121410-TP	SCREW 3/16-28 L=14	丸平ねじ 3/16-28 L=14	2
37		400-66876	SEAL LOWER	シールゴム下	1
38		B1444-180-00B	WASHER	振動リンク調節座金	1
39		400-66878	SPRING TOP COVER	上カバーばね	1
40		NS-6090310-SP	NUT 9/64-40	六角ナット 9/64-40	2
41		400-66880	LOOPER THROW OUT PLUNGER SPRING	ばね	1
42		400-66881	LOOPER THROW OUT BUSHING	ルーバーメタル	1
43		400-68368	LOOPER THROW OUT PLUNGER	フランジャー	1
44		400-66882	BEARING HOUSING ASSEMBLY	ベアリングハウジング組	1
45		401-12855	LIP SEAL	オイルシール	(1)
46		SS-8560612-TP	SCREW 1/4-40 L=6	止めねじ 1/4-40 L=6	(2)
47		SB-1200022-00	BEARING	ころがり軸受け	(1)
48		400-68371	RETAINING RING	リテーナーリング	(1)
49		400-68645	BEARING HOUSING	ベアリングハウジング	(1)
50		400-70015	O-RING	Oリング	(1)
51		400-66884	ADAPTOR BEARING	アダプターベアリング	(1)
52	*	WP-0480856-SP	WASHER 4.8X8.4X0.8	平座金 4.8 X 8.4 X 0.8	2
53		400-70075	PLUG SCREW	ねじ栓 M14	1
54		CQ-2000000-00	OIL WICK	油芯	0.2
55		400-66891	BUSHING CAP PLASTIC	プラスチックメタルキャップ	2
56		400-66892	PLUG SCREW	プラグねじ M10	1
57		400-66893	NEEDLE LEVER SHAFT BUSHING REAR	針シバー軸後メタル	1
58		400-66894	NEEDLE LEVER SHAFT BUSHING FRONT	針シバー軸前メタル	1
59		400-66895	CRANK SHAFT BUSHING REAR	上軸前メタル(圧入)	1
60		400-66896	MAIN SHAFT BUSHING CENTER	上軸中メタル(圧入)	1
61		401-12856	OIL SEAL	オイルシール	1
62		400-66898	MAIN SHAFT BUSHING FRONT	上軸後メタル(圧入)	1
63		400-66899	GASKET	ローラーエンドガスケット	1
64		400-70157	ROLLER END COVER	ローラーエンドカバー	1
65		SS-1090520-TP	SCREW 9/64-40 L=5	皿小ねじ 9/64-40 L=5	4
66		400-09520	SCREW 5/16-24 L=38	六角穴ボルト 5/16-24 L=38	3
67		400-66902	WASHER	アームベットの結合ボルト座金	3
68		400-66903	LOOPER THREAD GUIDE BASE	ルーバー糸案内板	1
69		SS-6110610-TP	SCREW 11/64-40 L=6	平ねじ 11/64-40 L=6	1
70		400-69957	THREAD GUIDE	糸案内板	1
71	#01	400-68376	LOOPER GUIDE COVER	ルーバー案内カバー(差動あり)	1
72		400-67249	CLAMP TUBE	糸案内クランプ	1
73		CM-3012000-01	SAFETY LABEL_S	頭部注意安全シール(小)	1
74		SS-6110610-TP	SCREW 11/64-40 L=6	平ねじ 11/64-40 L=6	3
75		400-83065	FELT	フェルト	1
76		400-66905	NEEDLE THREAD EYELET THREE HOLES	針糸調節糸道	1
77		SS-7110840-SP	SCREW 11/64-40 L=7.8	丸平ねじ 11/64-40 L=7.8	1
78		400-66906	NEEDLE THREAD EYELET THREE HOLES	針糸3穴端目	1
79		WP-0450801-SP	WASHER	平座金	1
80		SS-6110610-TP	SCREW 11/64-40 L=6	平ねじ 11/64-40 L=6	1
81		CM-3002000-01	ATTENTION SEAL	指げが注意シール(16)	3
82		CM-5003000-01	DIRECTION LABEL	方向ラベル	1
83		SS-4111015-SP	SCREW 11/64-40 L=10	なべねじ 11/64-40 L=10	3
84	#02	400-68378	LOOPER GUIDE PIPE	ルーバー案内パイプ(差動なし)	1
85		400-66890	OIL SHIELD	油防板	1
86		400-73130	RUBBER	防油ゴム	1
87		SS-7090850-SP	SCREW 9/64-40 L=8	丸平ねじ 9/64-40 L=8	2
88		WP-0370316-SD	WASHER 3.7X8X0.3	平座金 3.7 X 8 X 0.3	2
89		NS-6090310-SP	NUT 9/64-40	六角ナット 9/64-40	2

NOTE(注記) #01.....WITH DIFFERENTIAL FEED 差動あり  
#02.....WITHOUT DIFFERENTIAL FEED 差動なし

**2. FRAME MISCELLANEOUS, BEARING & FOLDER COMPONENTS (FOR MS-3580SF/0SN)**  
 頭部外装・軸受け・フォルダー関係 (MS-3580SF/0SN用)

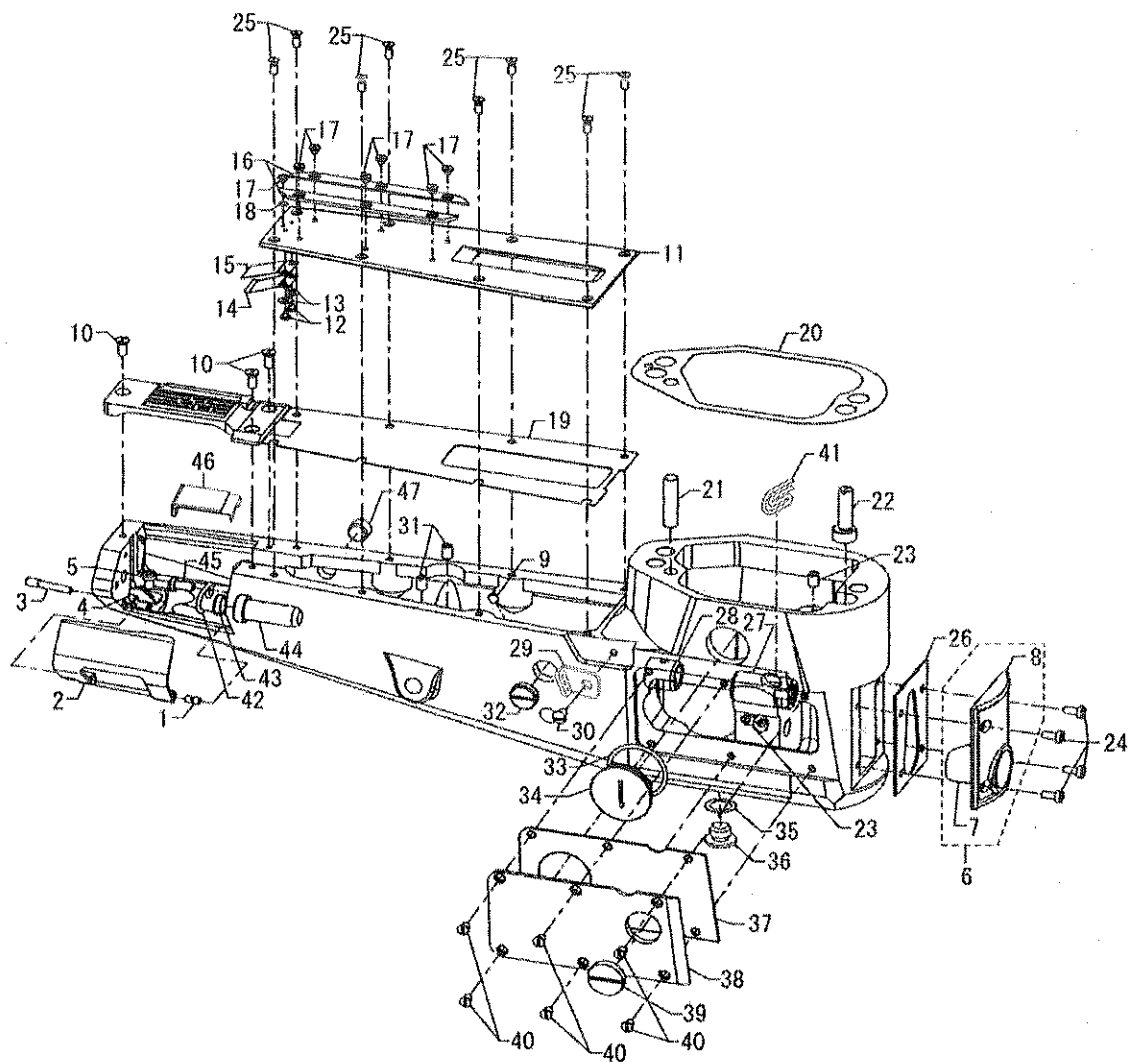

REF.NO	NOTE	PART NO	DESCRIPTION	品名	Qty
1		400-66909	PIN	ルーバーカバーヒンジピン	1
2		400-66911	LOOPER COVER	ルーバーカバー	1
3		400-66912	SCREW PIN	ルーバーカバーねじヒンジピン	1
4 ☆		400-66913	SPRING	板ばね	1
5		SS-6090670-TP	SCREW 9/64-40 L=6	平ねじ 9/64-40 L=6	1
6		400-66920	CYLINDER COVER AND OIL GAUGE	シリンダ前カバー	1
7		400-66923	OIL GAUGE	オイルゲージ	(1)
8		400-69993	CYLINDER COVER FRONT	シリンダカバー前	(1)
9		SS-8110520-TP	SCREW 11/64-40 L=4.5	止ねじ 11/64-40 L=4.5	1
10 ☆		400-69884	SCREW	針板止ねじ	3
11		400-68382	CYLINDER COVER	シリンダカバー	1
12		SS-4060310-SP	SCREW 3/32-56 L=2.5	なべねじ 3/32-56 L=2.5	2
13		400-70319	WASHER	座金	2
14		400-66914	CYLINDER LINT SHIELD UPPER	シールド上ばね	1
15		400-66915	CYLINDER LINT SHIELD SPRING	シールドばね	1
16		400-66916	SLIDE PLATE	スライド板	2
17		400-69883	SCREW	アタッチメント取付ねじ	7
18		WVS-0310002-UZ	WASHER	ばね座金 (プレス専用)	1
19		400-68383	GASKET	シリンダカバーガスケット	1
20		400-66917	GASKET	頭部結合ガスケット	1
21		400-66918	DOWEL PIN STRAIGHT	結合ピン	1
22		400-66919	ECCENTRIC PIN	針落ち調節偏心ピン	1
23		SS-8110710-SP	SCREW 11/64-40 L=6.5	止ねじ 11/64-40 L=6.5	2
24		SS-4080620-TP	SCREW 1/8-44 L=6	なべねじ 1/8-44 L=6	4
25		SS-2080810-SP	SCREW 1/8-44 L=7.5	丸皿ねじ 1/8-44 L=7.5	8
26		400-68384	GASKET	シリンダ前カバーパッキン	1
27		400-66924	LOOPER SHAFT BUSHING FRONT	ルーバー軸前メタル (DRU)	1
28		400-66925	LOOPER SHAFT BUSHING MIDDLE	ルーバー軸中メタル (DRU)	1
29		400-67013	LOOPER THREAD EYELET	ルーバー糸鳩目	1
30		SS-5090610-SP	SCREW 9/64-40 L=6	トラスねじ 9/64-40 L=6	1
31		SS-8110710-SP	SCREW 11/64-40 L=6.5	止ねじ 11/64-40 L=6.5	2
32		400-66927	PLUG SCREW	プラグねじ (M12 X 1.25)	1
33		400-66928	O RING	Oリング	1
34		400-66929	PLUG SCREW	プラグねじ (M25 X 1.5)	1
35		131-70105	RUBBER RING	Oリング	1
36		131-71004	DRAIN SCREW	廃油ねじ	1
37		400-68386	GASKET	パッキン	1
38		400-70350	CYLINDER SIDE COVER	シリンダ側カバー	1
39		TA-2050406-R0	RUBBER PLUG	止栓	1
40		SS-6090440-SP	SCREW 9/64-40 L=4.0	平ねじ 9/64-40 L=4	6
41		CQ-2000000-00	OIL WICK	油芯	0.6
42		400-70071	CYLINDER LOOPER THREAD GUIDE WIRE	ルーバー糸案内	1
43		401-12857	OIL SEAL FOR 35850G	オイルシール	1
44		400-66969	LOOPER SHAFT BUSHING REAR	ルーバー軸後メタル	1
45		SS-7090710-SP	SCREW 9/64-40 L=6.8	丸平ねじ 9/64-40 L=6.8	1
46		400-82006	LOWER LINT SHIELD ASM.	油防ゴム組	1
47		400-66975	PLUG SCREW	プラグねじ (M10 X 1.25)	1

3. FRAME MISCELLANEOUS, BEARING & FOLDER COMPONENTS (FOR MS-3580SF/1SN)  
 頭部外装・軸受け・フォルダー関係 (MS-3580SF/1SN用)

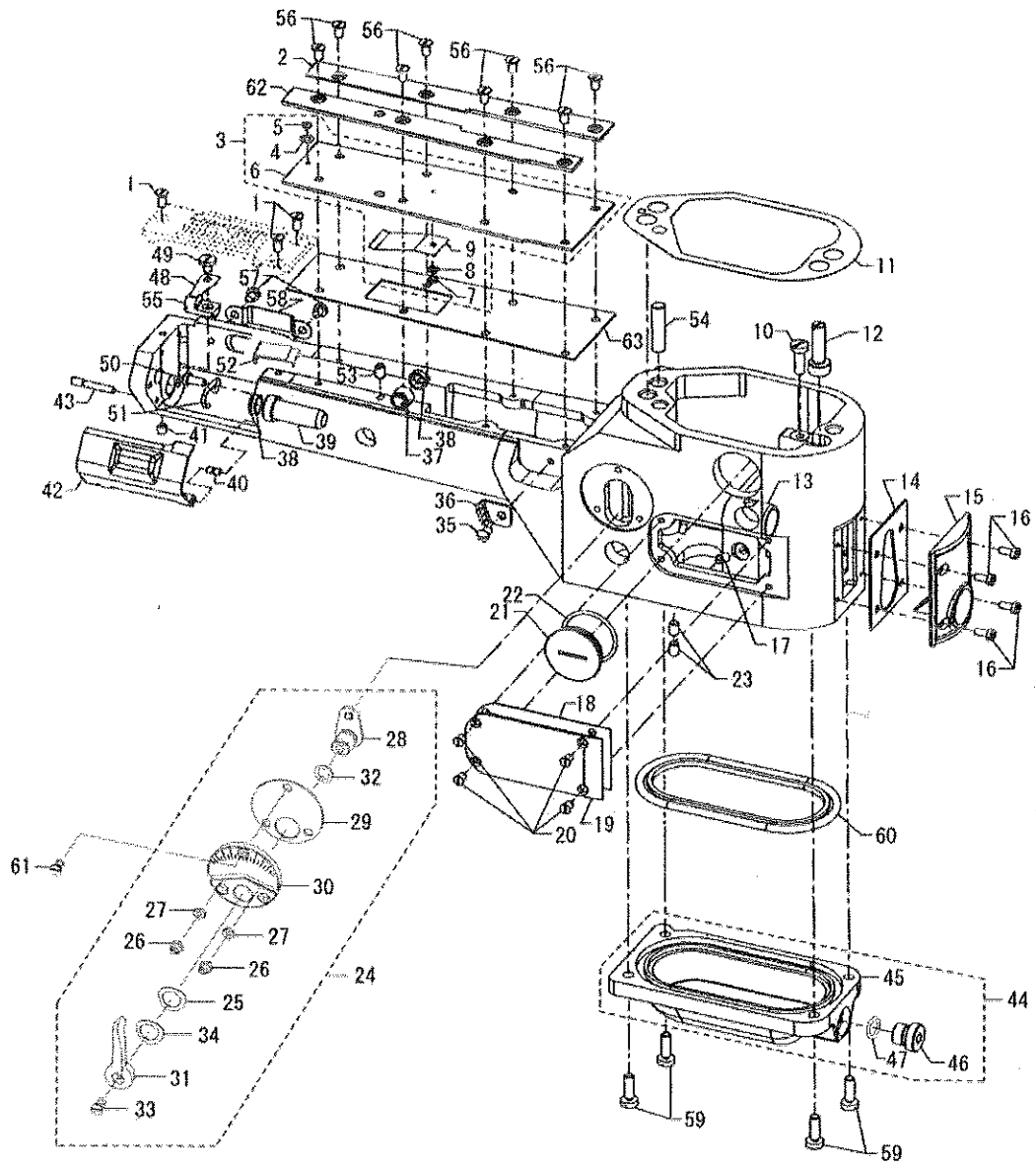

REF.NO	NOTE	PART NO	DESCRIPTION	品名	Qty
1	☆	400-69884	SCREW	針板止ねじ	3
2		400-66998	SLIDE PLATE RIGHT	スライド板右	1
3		400-69920	CYLINDER COVER ASM.	シリンダカバー組	1
4		WS-0310002-UZ	WASHER	ばね座金 (プレス専用)	(1)
5		400-69883	SCREW	アタッチメント取付ねじ	(1)
6		400-67001	CYLINDER COVER	シリンダカバー	(1)
7		400-69919	SCREW	ねじ	(1)
8		WP-0330500-MB	WASHER 3.3X6X0.5	平座金小形丸 M3	(1)
9		400-69921	SHIELD SPRING	板ばね	(1)
10		SS-7111410-TP	SCREW 11/64-40 L=14	丸平ねじ 11/64-40 L=14	1
11		400-66917	GASKET	頭部結合ガスケット	1
12		400-66919	ECCENTRIC PIN	針落ち調節偏心ピン	1
13		400-67003	LOOPER SHAFT BUSHING FRONT	ルーバー軸前メタル (DNU)	1
14		400-68384	GASKET	シリンダ前カバーパッキン	1
15		400-66920	CYLINDER COVER AND OIL GAUGE	シリンダ前カバー	1
16		SS-4080620-TP	SCREW 1/8-44 L=6	なべねじ 1/8-44 L=6	4
17		SS-8110710-SP	SCREW 11/64-40 L=6.5	止ねじ 11/64-40 L=6.5	1
18		400-68391	GASKET	シリンダサイドカバーパッキン	1
19		400-70346	CYLINDER SIDE COVER	シリンダサイドカバー	1
20		SS-6090440-SP	SCREW 9/64-40 L=4.0	平ねじ 9/64-40 L=4	4
21		400-66929	PLUG SCREW	プラグねじ (M2.5 X 1.5)	1
22		400-66928	O RING	Oリング	1
23		SS-8110710-SP	SCREW 11/64-40 L=6.5	止ねじ 11/64-40 L=6.5	2
24	*	400-74648	DIFF_FEED_CONTROL_ASSY	差動調整 (組)	1
25		400-67008	SPRING WASHER	曲げワッシャー	(1)
26		400-67009	STOP SCREW PIN	ストッパーピン	(2)
27		400-68392	NUT	ナット	(2)
28		400-74649	ADJUSTING LEVER	調整レバー結合	(1)
29		400-74653	GASKET	ガスケット	(1)
30		400-74654	ADJUSTING PLATE	目盛り板	(1)
31		400-74655	OPERATING LEVER	操作レバー	(1)
32		RO-0611801-00	RUBBER RING	Oリング	(1)
33		SM-1040950-TP	SCREW M4 L=9	皿小ねじ M4 L=9	(1)
34		WP-0951016-SP	WASHER 9.53X15X1	平座金 9.53 X 15 X 1	(1)
35		SS-5090610-SP	SCREW 9/64-40 L=6	トラスねじ 9/64-40 L=6	1
36		400-67013	LOOPER THREAD EYELET	ルーバー系端目	1
37		400-67014	BUSHING FOR FEED BAR ECCENTRIC STUD	送り棒偏心スタッドメタル	1
38		401-12857	OIL SEAL FOR 35850G	オイルシール	2
39		400-66969	LOOPER SHAFT BUSHING REAR	ルーバー軸後メタル	1
40		400-66909	PIN	ルーバーカバーピン	1
41		SS-8110710-SP	SCREW 11/64-40 L=6.5	止ねじ 11/64-40 L=6.5	1
42		400-67050	LOOPER COVER	ルーバーカバー	1
43		400-66912	SCREW PIN	ルーバーカバーねじピン	1
44		400-67055	BOTTOM COVER	油溜り組	1
45		400-69994	OIL RESERVOIR	油溜り	(1)
46		400-68448	OIL RESERVOIR SCREW	廃油ねじ	(1)
47		RO-0981901-00	RUBBER RING	Oリング	(1)
48	☆	400-67051	CYLINDER COVER SPRING	シリンダカバーばね	1
49		SS-7090510-SP	SCREW 9/64-40 L=4.6	丸平ねじ 9/64-40 L=4.6	1
50		SS-7090710-SP	SCREW 9/64-40 L=6.8	丸平ねじ 9/64-40 L=6.8	1
51		400-70071	CYLINDER LOOPER THREAD GUIDE WIRE	ルーバー系案内	1
52		400-82003	LOWER LINT SHIELD ASM.	油防ゴム組	1
53		SS-8110710-SP	SCREW 11/64-40 L=6.5	止ねじ 11/64-40 L=6.5	1
54		400-66918	DOWEL PIN STRAIGHT	結合ピン	1
55		400-68395	CYLINDER HINGED COVER SPRING SUPPORT STUD	シリンダーヒンジカバーばね	1
56		400-69882	SCREW	シリンダカバー止ねじ	8
57		SS-7090520-TP	SCREW 9/64-40 L=4.5	丸平ねじ 9/64-40 L=4.5	2
58		400-67054	CYLINDER GUARD FOR LOOPER	スーパーシリンダガード	1
59		SS-7111410-TP	SCREW 11/64-40 L=14	丸平ねじ 11/64-40 L=14	4
60		400-67059	GASKET	油溜りパッキン	1
61		SS-2090810-SP	SCREW 9/64-40 L=7.5	丸平ねじ 9/64-40 L=7.5	3
62		400-66996	SLIDE PLATE LEFT	スライド板左	1
63		400-68389	GASKET	シリンダカバーパッキン	1



#### 4. DETACHABLE HEAD COMPONENTS

ヘッド関係

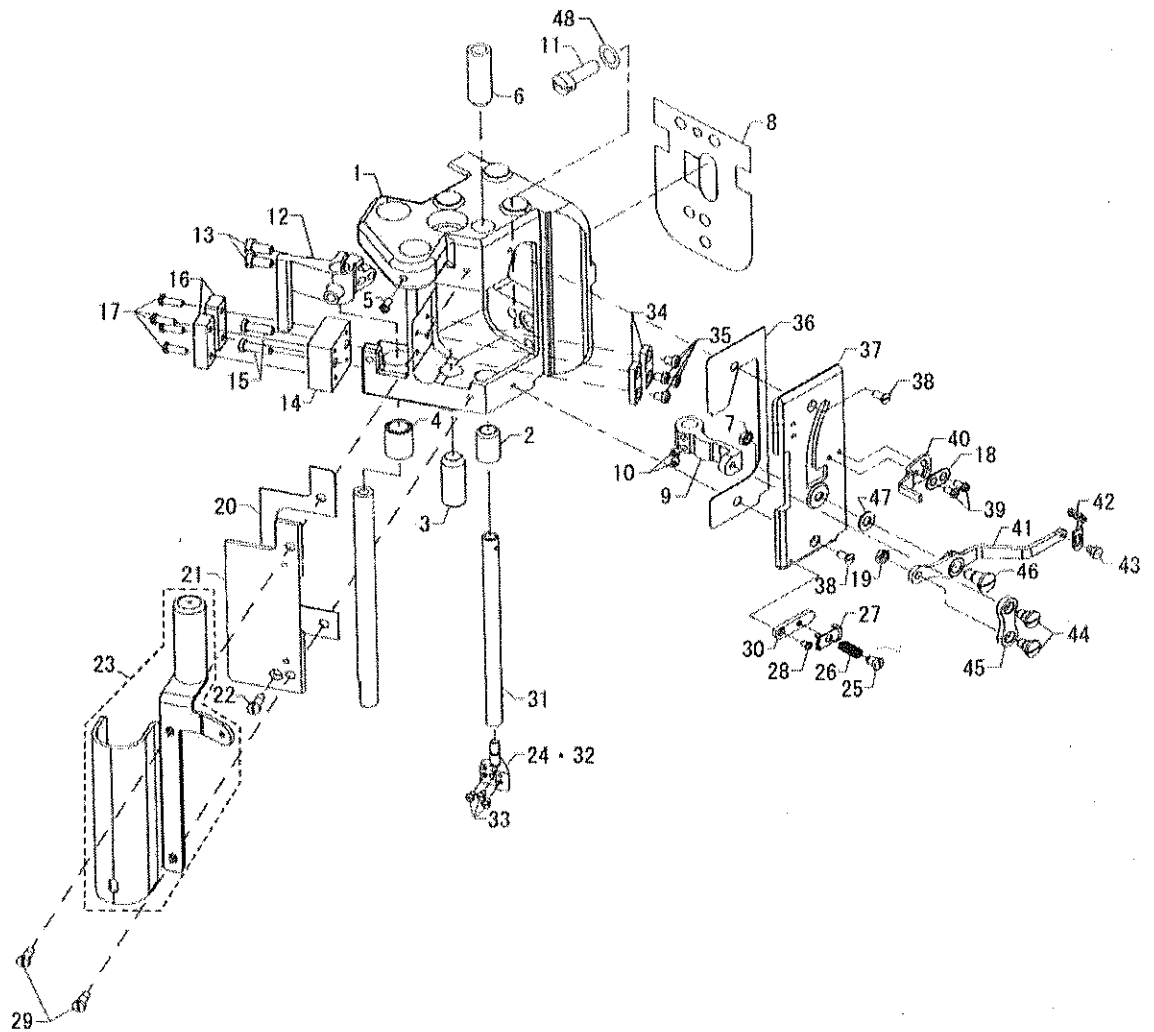

REF.NO	NOTE	PART NO	DESCRIPTION	品名	Qty
1		400-70158	DETACHABLE HEAD MASKING	分離ヘッドマスクング	1
2		400-82711	NEEDLE BAR LOWER BUSHING	針棒下メタル	1
3		400-67073	PRESSER BAR BUSHING	押え棒メタル	1
4		400-67074	BUSHING	メタル	1
5		400-82705	SCREW 3/16-28 L=12	なべねじ 3/16-28 L=12	1
6		400-82712	NEEDLE BAR UPPER BUSHING	針棒上メタル	1
7		NS-6150350-SP	NUT 15/64-28	六角ナット 15/64-28	2
8		400-67078	PLATE BAFFLE	プレートバツフル	1
9		400-68294	THREADED CONTROLLER ARM	針糸調節腕	1
10		SS-8110520-TP	SCREW 11/64-40 L=4.5	止めねじ 11/64-40 L=4.5	2
11		SM-6062002-TP	SCREW M6 L=20	六角穴ボルト M6 L=20	1
12		400-68293	GUIDE PLATE	ローラー棒ガイド板	1
13		SS-6121010-SP	SCREW 3/16-28 L=10	平ねじ 3/16-28 L=10	2
14		400-68397	BLOCK SUPPORT REAR GUIDE	ブロックサポート後方ガイド	1
15		SS-7121410-TP	SCREW 3/16-28 L=14	丸平ねじ 3/16-28 L=14	2
16		400-68398	GUIDE PLATE	左右ガイドプレート	2
17		SS-4091015-SP	SCREW 9/64-40 L=10	なべねじ 9/64-40 L=10	4
18		400-78404	WASHER PLATE	座金	1
19		NS-6110310-SP	NUT 11/64-40	六角ナット 11/64-40	1
20		400-68399	COVER HEAD LEFT GASKET	ヘッド左カバーガスケット	1
21		400-70141	SIDE COVER	側面カバー	1
22		SS-1090930-SP	SCREW 9/64-40 L=8.6	皿ねじ 9/64-40 L=8.6	1
23		400-67082	NEEDLE ROD ROLLER COVER ASM.	針棒ローラーカバー組	1
24	#02	400-67091	NEEDLE HEAD (7.2MM GAUGE)	針留 (7.2 mm ゲージ)	1
25		SD-0380551-SL	HINGE SCREW D=3.80 H=5.5	段ねじ D=3.8 H=5.5	1
26		B1132-521-000	THREAD PRESSER PLATE SPRING	針糸押え板ばね	1
27		101-29104	THREAD PRESSER PLATE	針糸押え板	1
28		SS-6090610-SP	SCREW 9/64-40 L=5.5	平ねじ 9/64-40 L=5.5	1
29		SS-7091110-TP	SCREW 9/64-40 L=10.5	丸平ねじ 9/64-40 L=10.5	2
30		400-68409	NEEDLE THREAD NIPPER BASE	針糸押え取付台	1
31		400-68401	NEEDLE BAR	針棒	1
32		400-67090	NEEDLE HEAD (6.4MM GAUGE)	針留 (6.4 mm ゲージ)	1
33	☆	SS-6080410-SP	SCREW 1/8-44 L=4	平ねじ 1/8-44 L=4	3
34		400-68402	PLATE GUIDE PRESSER BAR	押え棒ガイド板	2
35		SS-6090440-SP	SCREW 9/64-40 L=4.0	平ねじ 9/64-40 L=4	4
36		400-68403	COVER HEAD FRONT GASKET	ヘッド前面カバーガスケット	1
37		400-69768	FRONT HEAD COVER	フロントヘッドカバー (塗装完成)	1
38		SS-1090930-SP	SCREW 9/64-40 L=8.6	皿ねじ 9/64-40 L=8.6	2
39		SS-4080620-TP	SCREW 1/8-44 L=6	なべねじ 1/8-44 L=6	2
40		400-68405	NEEDLE THREAD HOLDER ADJUSTING PLATE	針糸受け調節板	1
41		400-67092	NEEDLE THREAD CONTROL LEVER	針糸調節天秤	1
42		400-67093	NEEDLE THREAD CONTROL LEVER EYELET	調節天秤糸案内	1
43		400-82960	SCREW 1/8-44 L=4.3	六角ボルト 1/8-44 L=4.3	1
44		400-68656	SHOULDER SCREW	段ねじ	2
45		400-67094	CONTROL LEVER CONNECTION LINK	リンク板	1
46		400-69800	SHOULDER SCREW	段ねじ	1
47		WP-0740516-SP	WASHER 7.4X11.8X0.5	平座金 7.4X11.8X0.5	2
48		WP-0651056-SD	WASHER 6.5X11X1	平座金 6.5X11X1	1
		NOTE(注記)	#01....FOR MS-3580 SF/△△N #02....FOR MS-3580 SG/△△N	MS-3580 SF/△△N 用 MS-3580 SG/△△N 用	

# 5. OIL LUBRICATION & NEEDLE DRIVING COMPONENTS

給油・針駆動関係

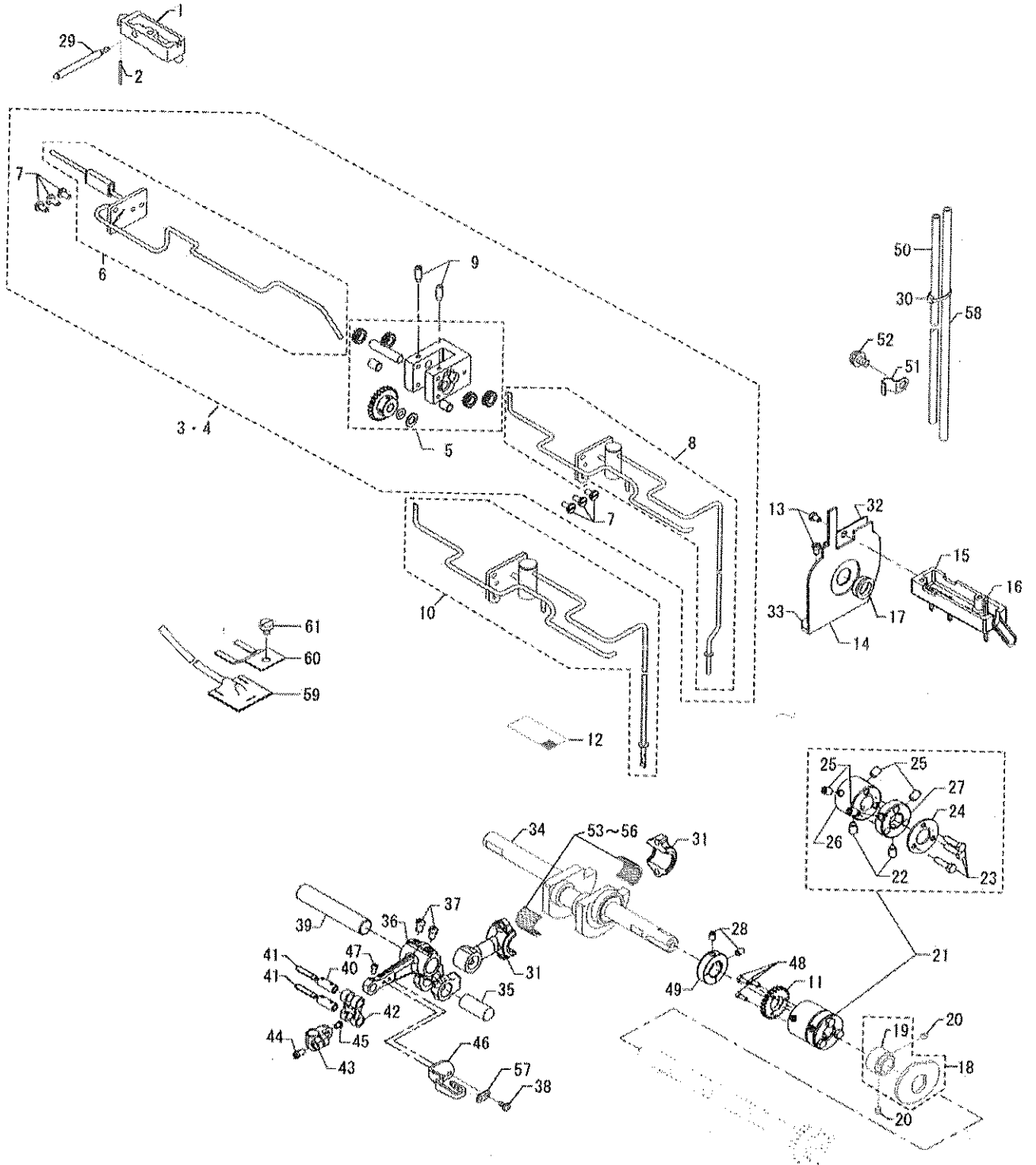

REF.NO	NOTE	PART NO	DESCRIPTION	品名	Qty
1		400-68410	OIL RESERVOIR BACK	オイルチューブ組	1
2		CQ-2000000-00	OIL WICK	油芯	0.11
3	#01	400-67100	OIL PUMP ASSEMBLY	オイルポンプ総組	1
4	#02	400-67101	OIL PUMP ASSEMBLY	オイルポンプ総組	1
5		400-68413	OIL PUMP ASSEMBLY	ポンプ台(組)	(1)
6		400-67102	OIL PUMP ASSEMBLY COVER REAR	オイルポンプ 後カバー組	(1)
7		SS-6090630-TP	SCREW 9/64-40 L=6	平ねじ 9/64-40 L=6	(6)
8	#01	400-68419	OIL PUMP HOUSING COVER FRONT ASM.	オイルポンプ前カバー組	(1)
9		400-68420	VENT SCREW FOR OIL PUMP	オイルポンプ用穴ねじ	(2)
10	#02	400-67109	OIL PUMP HOUSING COVER FRONT ASM.	オイルポンプ前カバー組	1
11		400-68426	OIL PUMP DRIVING GEAR	ロータリーポンプドライブギア	1
12	*	400-98071	FILTER	フィルター	1
13		SM-4040855-SP	SCREW	なべねじ	2
14		400-67118	GASKET	パッキン	1
15		400-67121	OIL RESERVOIR FRONT	油溜(前)	1
16		CQ-2000000-00	OIL WICK	油芯	0.4
17		401-12858	OIL SEAL RING	オイルシール リング	1
18		400-68421	LOWER THREAD CAM	下糸カム	1
19		400-67124	HUB BLANK	ハブブランク	(1)
20		SS-8110410-TP	SCREW 11/64-40 L=3.5	止ねじ 11/64-40 L=3.5	2
21		400-68422	MAIN SHAFT COUPLING	主軸カップリング	1
22		400-68601	SPOT SCREW	軸固定ねじ	(2)
23		400-70353	SCREW	M 4六角ボルト	(3)
24		400-68424	WASHER PLATE	座金	(1)
25		SM-8050812-TP	SCREW M5X8	止ねじ M5 X 0.8 L=8	(4)
26		400-68423	SHAFT COUPLING A	シャフトカップリング A	(1)
27		400-68425	SHAFT COUPLING B	シャフトカップリング B	(1)
28		SM-8050812-TP	SCREW M5X8	止ねじ M5 X 0.8 L=8	2
29		400-68921	OIL RESERVOIR OUTLET TUBE ASM.	油溜給油パイプ(組)	1
30		EA-9500B00-00	CLIP CV-70S	結束バンド60	4
31		400-68295	NEEDLE LEVER CONNECTION ROD	針駆動連結ロッド	1
32		400-67119	TAKE-UP SHIELD	主軸油防板	1
33		400-67120	FELT	フェルト	1
34		400-67125	CRANKSHAFT	クランク軸	1
35		400-81693	NEEDLE LEVER CONNECTION ROD ASM.	ニードルピン組	1
36		400-68312	NEEDLE LEVER	針棒駆動レバー	1
37		SS-6110650-TP	SCREW 11/64-40 L=5.5	平ねじ 11/64-40 L=5.5	2
38		SS-4080620-TP	SCREW 1/8-44 L=6	なべねじ 1/8-44 L=6	2
39		400-67132	NEEDLE LEVER SHAFT	針レバー軸	1
40		400-67133	LINK PIN	リンクピン	2
41		CQ-3030000-00	OIL WICK	油芯	0.45
42		400-68311	NEEDLE LEVER LINK	針棒駆動リンク	1
43		400-68377	NEEDLE BAR CONNECTION	針棒抱き	1
44	☆	SS-7111120-TP	SCREW	丸平ねじ	1
45		SS-6090510-TP	SCREW 9/64-40 L=5.0	平ねじ 9/64-40 L=5	1
46		400-68429	NEEDLE LEVER THREAD EYELET	針系レバー糸案内	1
47		SS-6080720-SP	SCREW	平ねじ 1/8-44 L=7	1
48		SM-6030850-TP	SCREW M3 L=8	平小ねじ M3 L=8	3
49		400-68427	COLLAR	上軸スラスト受	1
50		400-72351	OIL RETURN TUBE	還流パイプ	1
51		B3538-112-000	OIL RETURN TUBE HOLDER	還流パイプ押え	1
52		SL-4040881-SC	SCREW M4 L=8	座金付きなべ小ねじ M4 L=8	1
53	#03	400-75304	NEEDLE BEARING A	ニードルベアリング A	1
54	#03	400-75305	NEEDLE BEARING B	ニードルベアリング B	1
55	#03	400-75306	NEEDLE BEARING C	ニードルベアリング C	1
56	#03	400-75307	NEEDLE BEARING D	ニードルベアリング D	1
57		400-78404	WASHER PLATE	座金	1
58		BT-0500300-EA	OIL TUBE	ウレタンチューブ	0.19
59		400-82824	FELT ASM.	還流フェルト	1
60		400-82833	FELT PRESSER	還流フェルト押え	1
61		SM-6050660-TP	SCREW	平小ねじ M5 L=6	1
		NOTE(注記)	#01....WITH DIFFERENTIAL FEED #02....WITHOUT DIFFERENTIAL FEED #03....SELECTIVE PARTS	差動あり 差動なし 選択部品	

6. FEED MECHANISM COMPONENTS (FOR MS-3580SF/0SN)  
 送り関係 (MS-3580SF/0SN用)

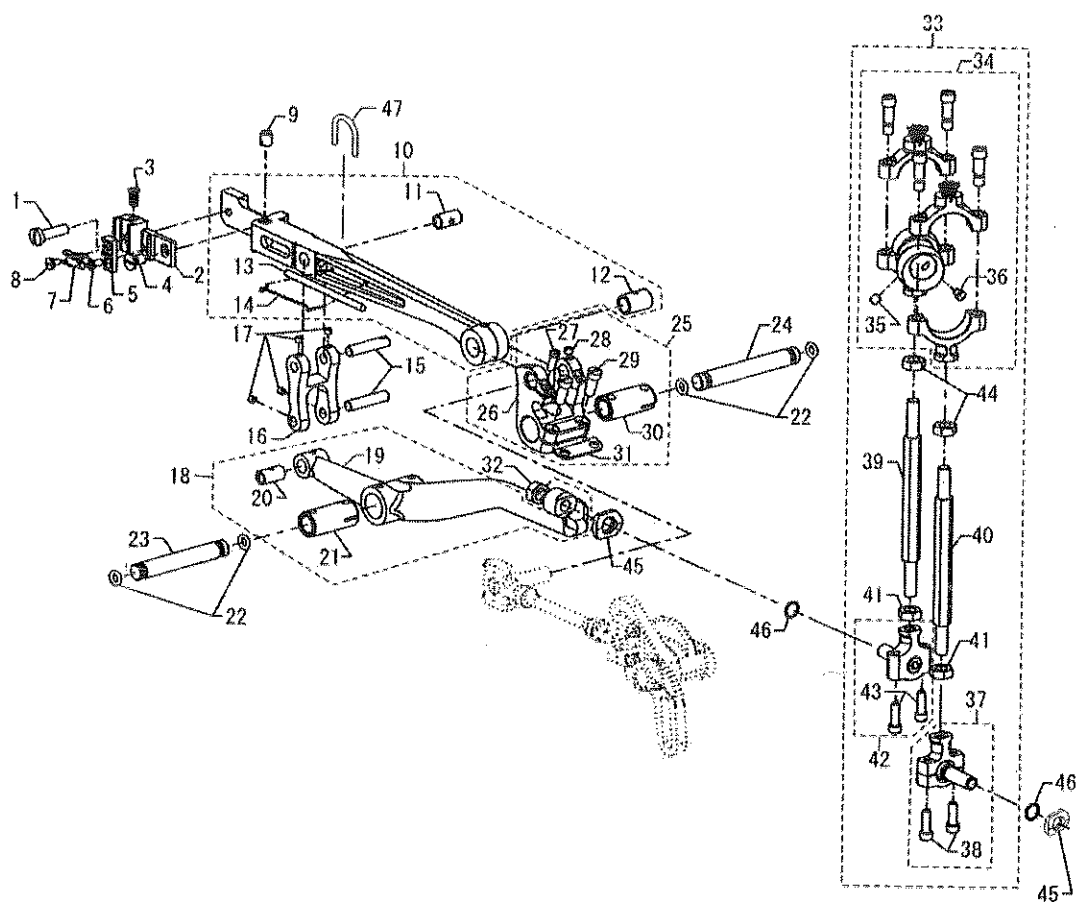

REF.NO	NOTE	PART NO	DESCRIPTION	品名	Qty
1		SS-6111620-SP	SCREW 11/64-40 L=16.0	平ねじ 11/64-40 L=16	1
2		400-67134	FEED DOG HOLDER	送り歯ホルダ	1
3	*	SS-2090710-TP	SCREW 9/64-40 L=7.2	丸皿ねじ 9/64-40 L=7.2	1
4	☆	SS-6110610-TP	SCREW 11/64-40 L=6	平ねじ 11/64-40 L=6	1
5		400-68430	NEEDLE GUARD HOLDER	針受けホルダ	1
6		400-68794	SCREW	ねじ	1
7	☆	400-68296	NEEDLE GUARD	針受け	1
8	☆	400-68794	SCREW	ねじ	1
9		SM-8061010-TP	SCREW	止めねじ M6 L=10	1
10		400-68431	FEED BAR ASM.	送り台(組)	1
11		400-67137	BUSHING	送り台メタル	(1)
12		400-67138	BUSHING	送り台メタル	(1)
13		400-68432	OIL FELT	給油フェルト	(2)
14		400-67139	WIRE SPRING CLIP	油芯押えばね	(1)
15		400-67140	LINK PIN	リンクピン	2
16		400-67141	LINK	リンク	1
17		SS-8080310-TP	SCREW 1/8-44 L=2.8	止ねじ 1/8-44 L=2.8	4
18		400-69753	FEED LIFTER LEVER ASM.	左送りレバー組	1
19		400-68433	FEED LIFTER LEVER	左送りレバー	(1)
20		400-67142	BUSHING	メタル	(1)
21		400-69453	FEED ROCKER BUSHING	ブッシング	(1)
22		400-68434	O RING	Oリング	4
23		400-67144	FEED LIFT LEVER SHAFT	送り上げレバー軸	1
24		400-67145	FEED ROCKER SHAFT	水平送り軸	1
25		400-68435	FEED ROCKER	水平送り	1
26		400-69155	FEED ROCKER	送り台腕	(1)
27	*	401-02214	SCREW	止めねじ	(1)
28		SS-8080310-TP	SCREW 1/8-44 L=2.8	止ねじ 1/8-44 L=2.8	(1)
29		SS-7111110-TP	SCREW 11/64-40 L=10.5	丸平ねじ 11/64-40 L=10.5	(2)
30		400-69453	FEED ROCKER BUSHING	ブッシング	(1)
31		400-67147	FEED ROCKER BUSHING KEY	水平送りメタルキー	(1)
32		NS-6660430-SP	NUT 1/4-40	六角ナット 1/4-40	1
33		400-67148	CONNECTING ROD ASSEMBLY	連結棒組	1
34		400-68436	AVOID ECCENTRIC	偏芯カム	(4)
35		SS-8110432-SP	SCREW 11/64-40 L=4.1	止ねじ 11/64-40 L=4.1	(1)
36		400-69886	SCREW	偏芯カムねじ	(1)
37		400-68444	BALL JOINT	ボールジョイント	(1)
38		400-69771	SCREW 9/64-40 L=12	丸平ねじ 9/64-40 L=12	(2)
39		400-68438	FEED LIFT ECCENTRIC CONNECTING ROD	送り上下連結ロッド	(1)
40		400-68439	COMBINATION ROD	ルーバ連結ロッド	(1)
41		NM-6050001-SP	NUT M5	六角ナット M5 X 0.8 1種	(2)
42		400-68441	BALL JOINT ASM.	ボールジョイント(組)	(1)
43		400-69771	SCREW 9/64-40 L=12	丸平ねじ 9/64-40 L=12	(2)
44		400-69918	NUT M6 LEFT	左ねじナット	(2)
45		400-68449	BALL SCREW BRACKET	ボールねじ受け台	2
46		400-67154	SHIM	調整シム	4
47		CQ-2000000-00	OIL WICK	油芯	0.2

# 7. FEED MECHANISM COMPONENTS (FOR MS-3580SF/1SN)

送り関係 (MS-3580SF / 1SN用)

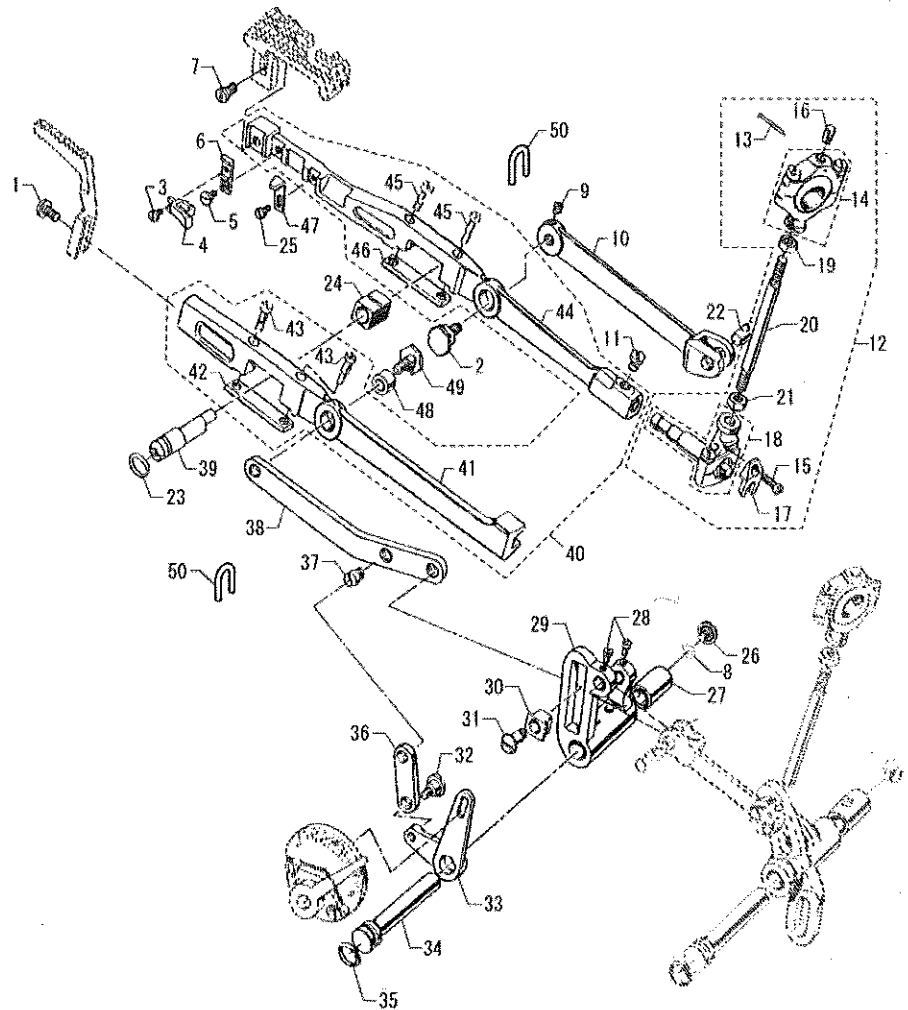

REF.NO	NOTE	PART NO	DESCRIPTION	品名	Qty
1		SS-6111010-TP	SCREW 11/64-40 L=9.5	平ねじ 11/64-40 L=9.5	1
2		400-67174	MAIN FEED BAR ECCENTRIC DRIVING STUD	送りリンクねじ	1
3	★	400-68794	SCREW	ねじ	1
4	★	400-68296	NEEDLE GUARD	針受け	1
5		400-68794	SCREW	ねじ	1
6		400-68430	NEEDLE GUARD HOLDER	針受けホルダ	1
7		SS-6111010-TP	SCREW 11/64-40 L=9.5	平ねじ 11/64-40 L=9.5	1
8		400-76295	RUBBER RING	Oリング	1
9		SM-80404A2-TP	SCREW M4 L=4	六角穴付き止ねじ M4 L=4	1
10		400-68451	MAIN FEED BAR DRIVING LINK	主送り棒駆動リンク	1
11		SS-6110710-TP	SCREW 11/64-40 L=6.5	平ねじ 11/64-40 L=6.5	1
12		400-67156	FEED LIFT ECCENTRIC ASSEMBLY FOR STYLES	送り上げ偏心組	1
13		118-56101	NEEDLE COOLER PIN	針冷却フェルト止ピン	(1)
14		400-68452	FEED LIFT ECCENTRIC ASSEMBLY BALL JOINT	左送り偏心組	(1)
15		SS-6080810-SP	SCREW 1/8-44 L=8.0	平ねじ 1/8-44 L=8	(1)
16		400-67149	FELT	給油フェルト	(1)
17		400-68461	BALL FORK	ボール止め板	(1)
18		400-68456	BALL JOINT COMPLETE	ボールジョイント	(1)
19		400-69918	NUT M6 LEFT	左ねじナット	(1)
20		400-68455	CONNECTING ROD	結合ロッド	(1)
21		NM-6050001-SP	NUT M5	六角ナット M5 X 0.8 1種	(1)
22		400-67155	LINK PIN	リンクピン	1
23		RO-0611801-00	RUBBER RING	Oリング	1
24		400-68470	FEED BAR SLIDE BLOCK	送り角こま	1
25	★	400-69085	SCREW	送り歯支え止ねじ	1
26		400-70073	SEALING SCREW	シーリングねじ	1
27		400-67161	BUSHING FOR FEED ROCKER SHAFT	水平送り軸メタル	1
28		SS-4080515-SP	SCREW 1/8-44 L=5	なべねじ 1/8-44 L=5	2
29		400-68463	FEED ROCKER	水平送り	1
30		400-67166	DIFFERENTIAL FEED DRIVING LINK SLIDE B	副送り駆動リンクスライドブロック	1
31		400-67167	DIFFERENTIAL FEED BAR DRIVING LINK STUD	副送り駆動リンクスタッド	1
32		400-70192	SCREW	ねじ	1
33		400-68465	DIFFERENTIAL FEED ADJUSTING LEVER	差動送り調節レバー	1
34		400-68466	FEED ROCKER SHAFT	水平送り軸	1
35		400-76293	RUBBER RING	Oリング	1
36		400-67168	DIFFERENTIAL FEED ADJUSTING LEVER LINK	副送り調節レバーリンク	1
37		400-70191	SCREW	ねじ	1
38		400-67169	DIFFERENTIAL FEED BAR DRIVING LINK	副送り棒駆動リンク	1
39		400-68467	FEED BAR ECCENTRIC STUD	送り偏心軸	1
40		400-69015	FEED ROCKER ASM.	送り揺動桿組	1
41		400-68468	DIFFERENTIAL FEED BAR	副送り揺動桿	(1)
42		400-68663	FEED BAR PLATE	送り揺動桿板	(1)
43		400-68664	SCREW	揺動桿板止ねじ	(2)
44		400-68469	MAIN FEED BAR	主送り揺動桿	(1)
45		400-68664	SCREW	揺動桿板止ねじ	(2)
46		400-68663	FEED BAR PLATE	送り揺動桿板	(1)
47	★	400-68297	MAIN FEED DOG SUPPORT	主送り歯支え	1
48		400-67172	BUSHING	送りリンクカラー	1
49		400-67173	DIFFERENTIAL FEED BAR DRIVING	送りリンクねじ	1
50		CQ-2000000-00	OIL WICK	油芯	0.12



8. LOOPER DRIVING COMPONENTS (FOR MS-3580SF/0SN)  
ルーパー駆動関係 (MS-3580SF / 0SN用)

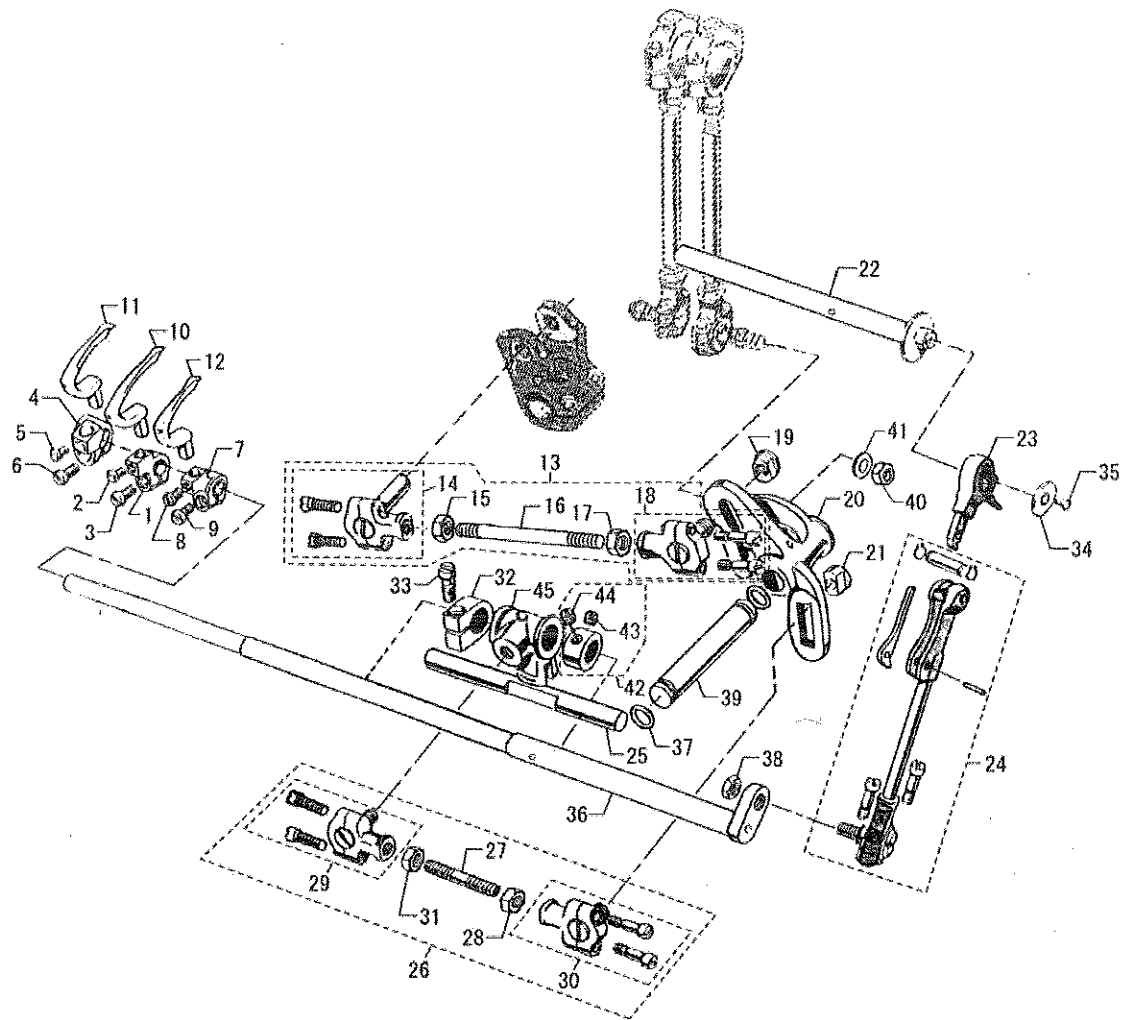

REF.NO	NOTE	PART NO	DESCRIPTION	品名	Qty
1		400-68471	LOOPER HOLDER MIDDLE	前ルーバー土台ルーバーホルダー (中)	1
2		400-75055	SCREW	ルーバー止めねじ	1
3	★	400-68817	SCREW	ルーバー台締めねじ	1
4		400-68472	LOOPER HOLDER LEFT	前ルーバー土台ルーバーホルダー (左)	1
5		400-75055	SCREW	ルーバー止めねじ	1
6	★	400-68817	SCREW	ルーバー台締めねじ	1
7		400-68473	LOOPER HOLDER RIGHT	前ルーバー土台ルーバーホルダー (右)	1
8	★	400-75055	SCREW	ルーバー止めねじ	1
9		400-68817	SCREW	ルーバー台締めねじ	1
10	★	400-68298	LOOPER MIDDLE	中ルーバー	1
11	★	400-68299	LOOPER LEFT	左ルーバー	1
12	★	400-68300	LOOPER RIGHT	右ルーバー	1
13		400-67176	FEED ROCKER CONNECTING ROD ASSEMBLY	水平送り連結ロッド組	1
14		400-68474	BALL JOINT	ボールジョイント	(1)
15		NM-6050001-SP	NUT M5	六角ナット M5 X 0.8 1種	(1)
16		400-67179	CONNECTING ROD	結合ロッド	(1)
17		400-69128	NUT M5X0.8 LEFT	左ねじナット	(1)
18		400-68522	BALL JOINT	ボールジョイント	(1)
19		400-67184	NUT	ナット	1
20		400-68525	FEED ROCKER AND LOOPER AVOID LEVER	水平送りルーバー偏芯レバー	1
21		400-67180	NUT	ナット	1
22		400-67183	SHAFT BLANK	主軸ブランク	1
23		400-68816	LOOPER DRIVE CONNECTION ASM.	ルーバー駆動連結 (組)	1
24		400-67181	LOOPER DRIVE CONNECTING ROD ASM.	ルーバー駆動連結ロッド組	1
25		400-68536	CROSS HEAD GUIDE SHAFT	クロスヘッドガイド軸	1
26		400-68537	CONNECTING ROD ASSEMBLY	結合ロッド組	1
27		400-68539	CONNECTING ROD	結合棒	(1)
28		400-69128	NUT M5X0.8 LEFT	左ねじナット	(1)
29		400-68538	BALL JOINT	ボールジョイント	(1)
30		400-68540	BALL JOINT	ボールジョイント	(1)
31		NM-6050001-SP	NUT M5	六角ナット M5 X 0.8 1種	(1)
32	*	400-74663	THRUST_COLLAR	スラストカラー	1
33	*	SM-6051202-TP	SCREW M5X0.8 L=12	六角穴ボルト M5 X 0.8 L=12	1
34		400-68531	MAIN SHAFT WASHER	主軸座金	1
35		SS-1110840-SP	SCREW 11/64-40 L=8	皿ねじ 11/64-40 L=8	1
36		400-68532	FEED ROCKER AND LOOPER LEVER SHAFT	水平送りルーバーレバー軸	1
37		RO-0611801-00	RUBBER RING	Oリング	2
38		NS-6660430-SP	NUT 1/4-40	六角ナット 1/4-40	1
39		400-68534	LOOPER ROCKER SHAFT	水平ルーバー軸	1
40		NS-6660430-SP	NUT 1/4-40	六角ナット 1/4-40	1
41		WP-0700616-SP	WASHER 7X11.6X0.6	平座金 7 X 11.6 X 0.6	1
42		400-67196	LOOPER SHAFT COLLAR	ルーバー軸カラー	1
43		SM-8040642-TP	SCREW	止めねじ M4 L=6	(1)
44		SM-80404A2-TP	SCREW M4 L=4	六角穴付き止めねじ M4 L=4	(1)
45		400-68535	LOOPER ROCKER SHAFT CROSS HEAD	水平ルーバー軸クロスヘッド	1

# 9. LOOPER DRIVING COMPONENTS (FOR MS-3580SF/1SN)

ルーパー駆動関係 (MS-3580SF / 1SN 用)

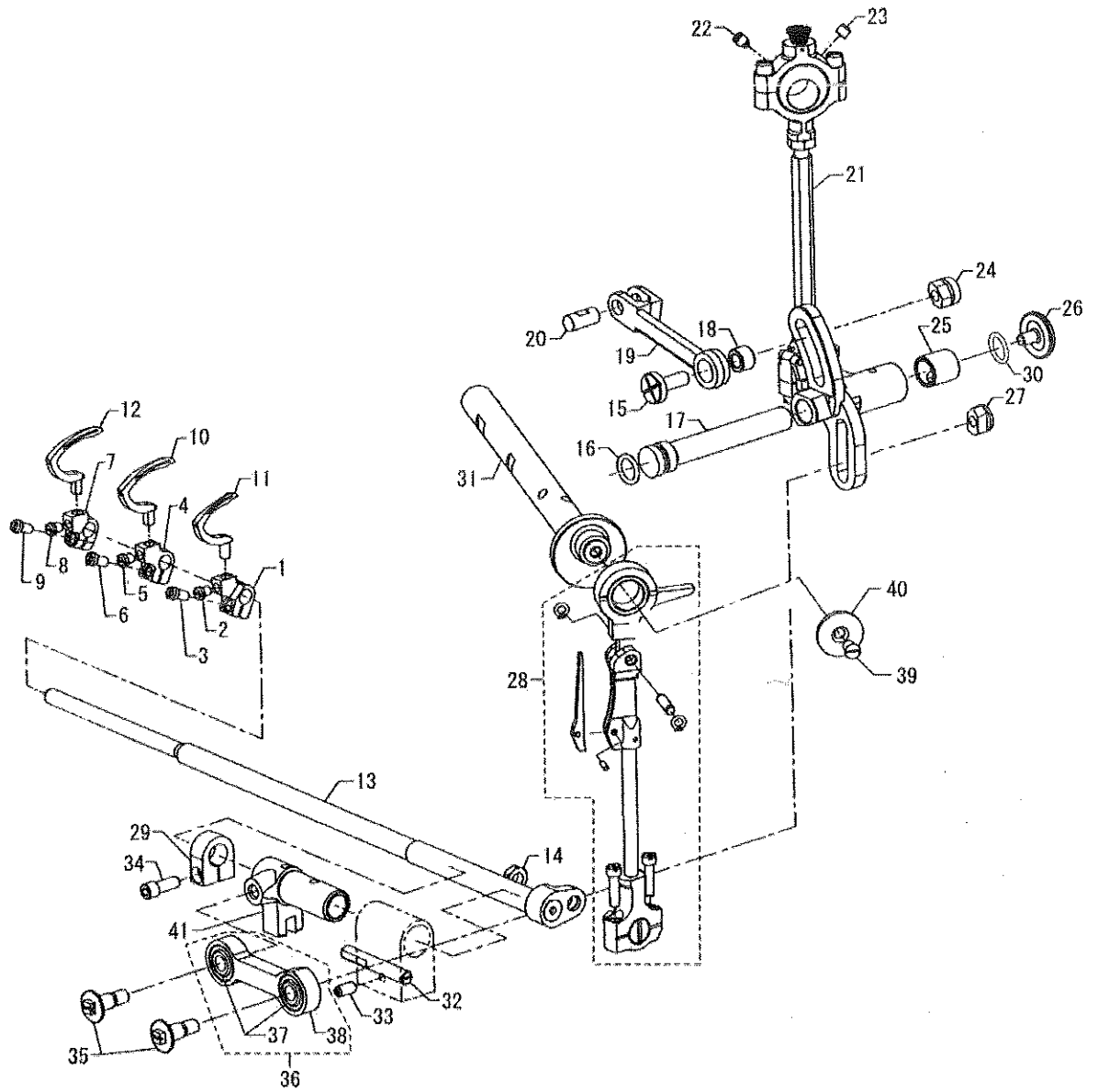

REF.NO	NOTE	PART NO	DESCRIPTION	品名	Qty
1		400-68473	LOOPER HOLDER RIGHT	前ルーバー土台ルーバーホルダー (右)	1
2	*	SS-6090510-TP	SCREW 9/64-40 L=5.0	平ねじ 9/64-40 L=5	1
3	☆	400-68817	SCREW	ルーバー台締めねじ	1
4		400-68471	LOOPER HOLDER MIDDLE	前ルーバー土台ルーバーホルダー (中)	1
5	*	SS-6090510-TP	SCREW 9/64-40 L=5.0	平ねじ 9/64-40 L=5	1
6	☆	400-68817	SCREW	ルーバー台締めねじ	1
7		400-68472	LOOPER HOLDER LEFT	前ルーバー土台ルーバーホルダー (左)	1
8	*	SS-6090510-TP	SCREW 9/64-40 L=5.0	平ねじ 9/64-40 L=5	1
9	☆	400-68817	SCREW	ルーバー台締めねじ	1
10	☆	400-68298	LOOPER MIDDLE	中ルーバー	1
11	☆	400-68300	LOOPER RIGHT	右ルーバー	1
12	☆	400-68299	LOOPER LEFT	左ルーバー	1
13		400-68543	LOOPER ROCKER SHAFT	水平ルーバー軸	1
14		NS-6660430-SP	NUT 1/4-40	六角ナット 1/4-40	1
15		400-67200	FEED ROCKER DRIVING LINK SCREW	水平送り駆動リンクねじ	1
16		400-76293	RUBBER RING	Oリング	1
17		400-68466	FEED ROCKER SHAFT	水平送り軸	1
18		400-67172	BUSHING	送りリンクねじ	1
19		400-68545	FEED ROCKER DRIVING LINK	水平送り駆動リンク	1
20		400-67155	LINK PIN	リンクピン	1
21		400-68546	FEED DRIVE ASSEMBLY	送り駆動組	1
22		400-69886	SCREW	偏芯カムねじ	1
23		SS-8110432-SP	SCREW 11/64-40 L=4.1	止ねじ 11/64-40 L=4.1	1
24		400-67184	NUT	ナット	1
25		400-67161	BUSHING FOR FEED ROCKER SHAFT	水平送り軸メタル	1
26		400-70073	SEALING SCREW	シーリングねじ	1
27		400-67201	NUT	ナット	1
28		400-67181	LOOPER DRIVE CONNECTING ROD ASM.	ルーバー駆動連結ロッド 組	1
29		400-68302	THRUST COLLAR	スラスト受け抱き	1
30		400-76295	RUBBER RING	Oリング	1
31		400-67183	SHAFT BLANK	主軸ブラック	1
32		400-67202	STUD FOR LOOPER SHAFT SLEEVE	ルーバー軸 スリーブスタッド	1
33		SS-8110710-SP	SCREW 11/64-40 L=6.5	止ねじ 11/64-40 L=6.5	1
34		SM-6041202-TP	SCREW M4X0.7 L=12	六角穴ボルト	1
35		400-70093	SCREW	段ねじ	2
36		400-69776	CONNECTING ROD BEARING ASM.	結合ロッドベアリング組	1
37		400-69777	BEARING	ベアリング	(2)
38		400-67203	CONNECTING ROD BEARING SHELL	連結ロッド	(1)
39		SS-1110840-SP	SCREW 11/64-40 L=8	皿ねじ 11/64-40 L=8	1
40		400-68531	MAIN SHAFT WASHER	主軸座金	1
41		400-68303	LOOPER SHAFT SLEEVE	ルーバー軸受	1

# 10. UPPER ROLLER FEED & THREAD TENSION COMPONENTS

上ローラー送り・糸調子関係

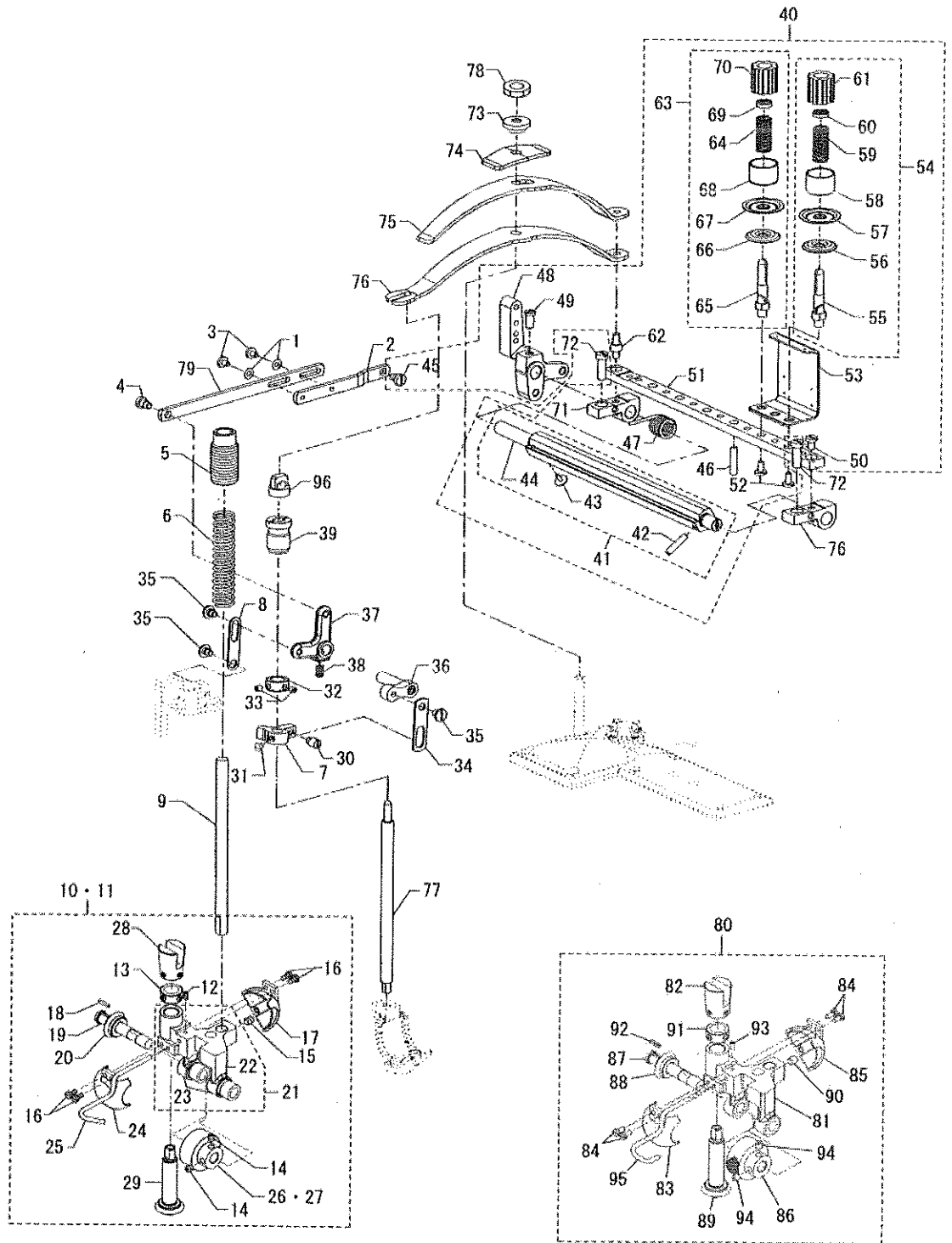

REF.NO	NOTE	PART NO	DESCRIPTION	品名	Qty
1		WP-0380516-SD	WASHER	平座金	2
2		400-67207	LIFTER LEVER	リフターレバー	1
3		SS-4090715-SP	SCREW 9/64-40 L=7	なべねじ 9/64-40 L=7	2
4		400-70175	SCREW	段ねじ	1
5		400-68554	PULLER BAR KNOB TOP	プーラー棒上メタルねじ	1
6		400-68555	SPRING PULLER BAR	引き棒ばね	1
7		400-68572	PRESSER BAR LIFTER AND GUIDE	押え上げガイド	1
8		400-68556	LIFTER LEVER BELL CRANK LINK	押え上げリンク	1
9		400-67089	PRESSER BAR	押え軸	1
10	#01	400-67209	PULLER ASSEMBLY	プーラー組	1
11	#02	400-77683	PULLER ASSEMBLY	プーラー組	1
12		SM-8030602-TP	SCREW M3X0.5 L=6	止めねじ M3X0.5 L=6	(1)
13		400-68558	DRIVE GEAR COLLAR ASM.	ドライブギアカラー組	(1)
14		SS-8110422-TP	SCREW 11/64-40 L=4	止めねじ 11/64-40 L=4	(2)
15		SM-8050612-TP	SCREW M5X6	止めねじ M5X0.8 L=6	(1)
16		SM-6030650-TP	SCREW	平小ねじ M3 L=6	(4)
17		400-68559	GEAR GUARD REAR	ギアカバー (後)	(1)
18		400-68560	STRAIGHT KEY	ストレートキー	(1)
19		400-68561	FEED ROLLER SHAFT	上送りローラー軸	(1)
20		400-68562	DRIVEN MITER GEAR	従動ギア	(1)
21		400-68593	FEED ROLLER FRAME ASM.	上送りローラーフレーム組	(1)
22		400-68564	FEED ROLLER FRAME	上送りローラーフレーム	(1)
23		400-68565	NEEDLE BEARING	針ベアリング	(2)
24		400-68566	GEAR COVER FRONT	ギアカバー (前)	(1)
25		400-73864	FINGER GUARD	指ガード	(1)
26	#01	400-68568	FEED ROLLER STEEL	上送りローラー	(1)
27	#02	400-77682	FEED ROLLER STEEL (REVERSE TEETH)	上送りローラー (逆歯)	(1)
28		400-67213	FEED ROLLER LOWER CONNECTION	送りローラー下連結	(1)
29		400-68563	DRIVE MITER GEAR	駆動ギア	(1)
30		400-70177	SCREW	ねじ	1
31		SS-7110540-SP	SCREW 11/64-40 L=5	丸平ねじ 11/64-40 L=5	1
32		400-68573	COLLAR	カラー	1
33	*	SS-6090620-TP	SCREW	平ねじ	2
34		400-67218	LIFTER LINK	レバーリンク	1
35		400-78418	SHOULDER SCREW	段ねじ	3
36		400-68304	PRESSER BAR LIFTER LEVER	押え棒上げレバー	1
37		400-68574	LIFTER LEVER LINK	リフトレバーリンク	1
38		SS-8150822-TP	SCREW 15/64-28 L=8	止めねじ 15/64-28 L=8	1
39		400-67075	PRESSER BAR BUSHING	押え棒メタル	1
40	*	400-69985	THREAD TENSION CONTROL UNIT	糸張力調整ユニット	1
41		400-68575	TENSION RELEASE SHAFT ASM.	糸緩め軸 (結合)	(1)
42		PS-0400202-KP	SPRING PIN TYPE W 4X20	スプリングピン W形 4X20	(1)
43		SM-7030450-SC	SCREW M3X0.5 L=4	丸平子ねじ M3X0.5 L=4	(1)
44		400-67221	TENSION RELEASE SHAFT BLK	糸緩め軸	(1)
45	*	400-70175	SCREW	段ねじ	(1)
46		400-67224	TENSION DISC RELEASE PIN	皿浮かしピン	(7)
47		400-67225	TENSION RELEASE SHAFT SPRING	浮かし軸ばね	(1)
48		400-68305	LIFTER LEVER	上げレバー	(1)
49		SS-9151160-CP	SCREW 15/64-28 L=10.5	六角ボルト 15/64-28 L=10.5	(1)
50		SS-6120940-SP	SCREW 3/16-28 L=9	平ねじ 3/16-28 L=9	(1)
51		400-67226	TENSION SUPPORT	糸調子台	(1)
52		SS-6090630-TP	SCREW 9/64-40 L=6	平ねじ 9/64-40 L=6	(6)
53		400-68576	TENSION THREAD EYELET	糸調子案内板	(3)
54		400-68840	LOOPER THREAD TENSION CONTROL ASM.	ルーバー糸調子 (組)	(3)
55		400-67227	TENSION POST	糸調子棒	(1)
56		400-68577	TENSION DISC SMALL	糸調子皿小	(1)
57		400-68578	TENSION DISC LARGE	上テンション皿	(1)
58		400-67228	SHIELD TENSION SPRING	糸調子皿押さえ	(1)
59		400-67229	LOOPER THREAD TENSION SPRING FOR LOOPER	ルーバー糸調子ばね	(1)
60		400-68580	TENSION POST FERRULE	糸調子ナット廻り止め	(1)
61		400-67230	TENSION NUT	糸調子つまみ	(1)
62		400-67231	PRESSER SPRING REST	押えばね掛けピン	(1)
63		400-69841	NEEDLE THREAD TENSION CONTROLLER ASM.	針棒糸調子 (組)	(3)
64		400-68579	NEEDLE THREAD TENSION SPRING FOR NEEDLE	針糸調子ばね	(1)
65		400-67227	TENSION POST	糸調子棒	(1)
66		400-68577	TENSION DISC SMALL	糸調子皿小	(1)
67		400-68578	TENSION DISC LARGE	糸調子皿大	(1)
68		400-67228	SHIELD TENSION SPRING	糸調子皿押さえ	(1)
69		400-68580	TENSION POST FERRULE	糸調子ナット廻り止め	(1)
70		400-67230	TENSION NUT	糸調子つまみ	(1)
71		400-67223	TENSION PLATE BRACKET	テンションプレートブラケット	(2)
72		SM-6051202-TP	SCREW M5X0.8 L=12	六角穴ボルト M5X0.8 L=12	2
73		400-67232	PRESSER REGULATING SCREW	圧力調節ナット	1
74		400-67233	PRESSER SPRING PLATE	押えばね小	1
75		400-67234	PRESSER SPRING UPPER	圧力調節板ばね上	1
76		400-67235	PRESSER SPRING LOWER	圧力調節板ばね下	1
77		400-67217	PRESSER BAR	押え棒	1
78		NM-6060003-SP	NUT M6 TYPE3	六角ナット M6 3種	1
79		400-70491	LIFTER LEVER LINK	押え上げレバーリンク	1
80	* #03	401-20356	PULLER ASSEMBLY	プーラー組 (アヤメ)	1
81		400-84993	FEED ROLLER FRAME ASM	上送りローラーフレーム組	(1)
82		400-67213	FEED ROLLER LOWER CONNECTION	送りローラー下連結	(1)
83		400-68566	GEAR GUARD FRONT	正面ギアカード	(1)
84		SM-6030650-TP	SCREW	平小ねじ M3 L=6	(4)
85		400-68559	GEAR GUARD REAR	後ギアカード	(1)
86		401-18632	ROLLER FOR THIN CLOTH	薄物用ローラ	(1)
87		400-68561	FEED ROLLER SHAFT	送りローラー軸	(1)
88		400-68562	DRIVEN MITER GEAR	従動ギア	(1)
89		400-68563	DRIVE MITER GEAR	駆動ギア	(1)
90		SM-8050612-TP	SCREW M5X6	止めねじ M5X0.8 L=6	(1)
91		400-68558	DRIVE GEAR COLLAR ASM	ドライブギアカラー組	(1)
92		400-68560	STRAIGHT KEY	ストレートキー	(1)
93		SM-8030602-TP	SCREW M3X0.5 L=6	止めねじ M3X0.5 L=6	(1)
94		SS-8110422-TP	SCREW 11/64-40 L=4	止めねじ 11/64-40 L=4	(2)
95		400-73864	FINGER GUARD	指ガード	(1)
96		400-67220	PRESSER BAR KNOB	押えノブ	1

NOTE(注記)

#01...FOR MS-3580 S△/△SN  
#02...FOR MS-3580 S△/△RN  
#03...OPTIONAL PARTS

MS-3580 S△/△SN用  
MS-3580 S△/△RN用  
オプション部品



REF.NO	NOTE	PART NO	DESCRIPTION	品名	Qty
1		NS-6150430-SP	NUT 15/64-28	六角ナット 15/64-28	1
2		SS-1090750-SP	SCREW 9/64-40 L=7	下メス取付けねじ	3
3		400-67242	WASHER	プーリーワッシャー	1
4		400-67243	PULLEY	プーリー	1
5		SS-8150822-TP	SCREW 15/64-28 L=8	止ねじ 15/64-28 L=8	2
6		400-67284	FEED ROLLER DRIVE FLOATING CONNECTION	ローラー接続機	1
7		400-67285	FEED ROLLER CONNECTION UPPER	ローラー接続腕上	1
8		SS-8110422-TP	SCREW 11/64-40 L=4	止ねじ 11/64-40 L=4	2
9		400-68581	CONNECTING ROD AND CLUTCH DRIVING ECCENT	連結ロッド組	1
10		400-68585	CONNECTING ROD	連結ロッド	(1)
11		400-68584	NEEDLE BEARING	ニードルベアリング	(1)
12		400-67241	BEARING	ころがり軸受け	(1)
13		400-68583	SHOULDER SCREW	段付ねじ	(1)
14		400-67240	OIL WICK	フェルト	(1)
15		SM-8050612-TP	SCREW M5X6	止ねじ M5X0.8 L=6	(2)
16		NS-6660430-SP	NUT 1/4-40	六角ナット 1/4-40	(1)
17		400-68582	ECCENTRIC	偏心カラー	(1)
18		WP-0651056-SH	WASHER 6.5X11X1	平座金 6.5X11X1	(1)
19		400-68828	CLUTCH CONNECTION LOT ASM.	クラッチ接続ロッド組	1
20		400-68594	ROLLER CLUTCH BALL JOINT ASSEMBLY LEFT	ボールジョイント左(組)	(1)
21		400-68595	SHELL	ジョイント	(1)
22		400-68596	BALL STUD	ボール腕左	(1)
23		400-69771	SCREW 9/64-40 L=12	丸平ねじ 9/64-40 L=12	(2)
24		400-68592	BALL JOINT ASSEMBLY RIGHT	ボールジョイント右(組)	(1)
25		400-68542	SHELL	ジョイント(右)	(1)
26		400-68593	LOOPER LEVER BAL STUD	ボール腕右	(1)
27		400-68591	WASHER	ワッシャー	(1)
28		400-69771	SCREW 9/64-40 L=12	丸平ねじ 9/64-40 L=12	(2)
29		400-67245	ROLLER CLUTCH CONNECTING ROD	連結ロッド	(1)
30		400-69128	NUT M5X0.8 LEFT	左ねじナット	(1)
31		NM-6050001-SP	NUT M5	六角ナット M5X0.8 1種	(1)
32		NS-6150430-SP	NUT 15/64-28	六角ナット 15/64-28	1
33		WP-0621026-SP	WASHER 6.2X9.5X1	平座金 6.2X9.5X1	1
34		400-69460	SCREW 5/16-24	ねじ 5/16-24 L=27	1
35		WP-0951016-SP	WASHER 9.53X15X1	平座金 9.53X15X1	1
36		400-67244	SEGMENT LEVER BUSHING	スリーブ	1
37		400-68306	CLUTCH CONNECTION LOT LEVER	クラッチ接続レバー	1
38		WP-0621026-SP	WASHER 6.2X9.5X1	平座金 6.2X9.5X1	2
39		PS-0200182-KP	SPRING PIN TYPE W2X18	スプリングピン W形 2X18	1
40		400-67272	CONSTANT WEDGE ANGLE CLUTCH ASM.	クラッチ組	1
41	*	SS-6060510-TP	SCREW 3/32-56 L=4.5	平ねじ 3/32-56 L=4.5	(6)
42		400-68600	CLUTCH DISC	送りクラッチ	(2)
43		400-67274	CLUTCH ROLLER	クラッチローラー	(6)
44		400-67273	CLUTCH DRIVE LEVER	クラッチ駆動レバー	(1)
45		400-68601	SPOT SCREW	軸固定ねじ	(1)
46		400-67276	CONSTANT WEDGE ANGLE CLUTCH BARREL ASM	クラッチバルレル組	(1)
47		400-68602	BARREL CORE	クラッチカラー	(1)
48		400-68598	CLUTCH SPRING CAP	クラッチばねキャップ	(12)
49		SS-1090930-SP	SCREW 9/64-40 L=8.6	皿ねじ 9/64-40 L=8.6	(3)
50		400-67275	CLUTCH ROLLER SPRING	ローラー圧縮ばね	(12)
51		400-67281	LOCKING SPACER PLATE	固定板	(1)
52		400-67282	LOWER BEARING	下ベアリング	(1)
53		SS-7090530-SP	SCREW 9/64-40 L=4.5	丸平ねじ 9/64-40 L=4.5	(3)
54		400-68603	FEED DRIVE SHAFT	送り軸	(1)
55		400-67283	FEED CUP SHAFT COLLAR	カラー	(1)
56		SS-6090440-SP	SCREW 9/64-40 L=4.0	平ねじ 9/64-40 L=4	(2)
57		NS-6120630-SP	NUT 3/16-28	六角ナット 3/16-28	(1)
58		NS-6700320-SP	NUT 5/16-24	六角ナット 5/16-24	(1)
59		400-82015	WASHER	ブレーキ座金	(1)
60		400-68599	BRAKE SPRING	ブレーキばね座金	(1)
61		400-81999	CLUTCH THRUST WASHER	クラッチ軸座金	(1)



## 12. SEWING PARTS COMPONENTS

ゲージ関係

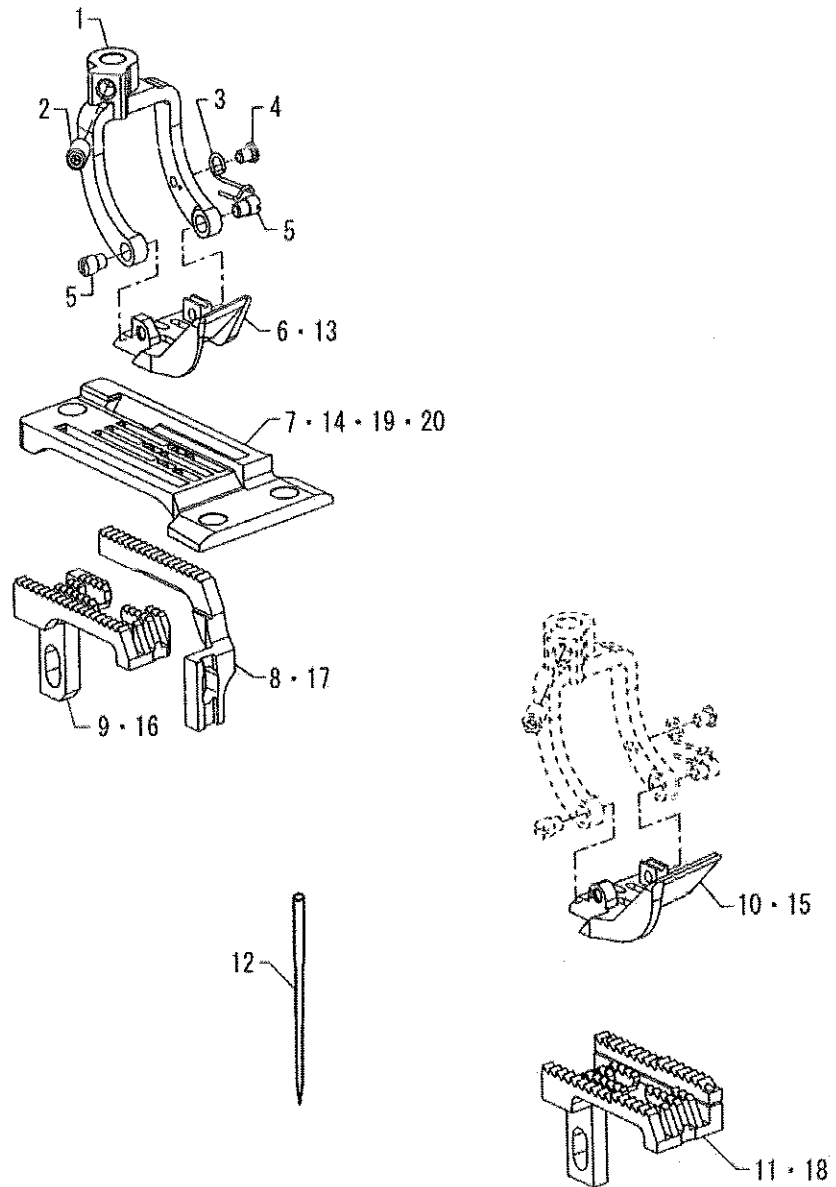

REF.NO	NOTE	PART NO	DESCRIPTION	品名	Qty
1		400-67286	PRESSER FOOT FORK	押え足支え	1
2	★	SS-8110422-TP	SCREW 11/64-40 L=4	止ねじ 11/64-40 L=4	1
3	★	400-67287	SPRING	押え足ばね	1
4		400-70194	SCREW	ねじ	1
5	★	400-70193	SCREW	ねじ	2
6	#01	400-67289	PRESSER FOOT 6.4MM GAUGE	押え (差動あり 6.4 mm ゲージ用)	1
7	#07	400-67292	THROAT PLATE 6.4MM GAUGE	針板 (6.4 mm ゲージ用)	1
8	★	400-67295	DIFFERENTIAL FEED DOG	差動送り歯	1
9	#05	400-70054	FEED DOG	送り歯	1
10	#03	400-67297	PRESSER FOOT 6.4MM GAUGE	押え (差動なし 6.4 mm ゲージ用)	1
11	#06	400-68612	FEED DOG FOR 6.4MM AND 7.2MM GAUGE STYLES	送り歯	1
12	★	MUY-130B1400	NEEDLE UY130GS NM140	針 UY130GS NM140	3
13	#02	400-67290	PRESSER FOOT 7.2MM GAUGE	押え (差動あり 7.2 mm ゲージ用)	1
14	#08	400-67293	THROAT PLATE 7.2MM GAUGE	針板 (7.2 mm ゲージ用)	1
15	#04	400-67298	PRESSER FOOT 7.2MM GAUGE	押え (差動なし 7.2 mm ゲージ用)	1
16	* #09	401-07500	MAIN FEED DOG	薄物用主送り歯	1
17	* #09	401-07501	DIFFERENTIAL FEED DOG	薄物用差動送り歯	1
18	* #10	401-07503	FEED DOG	薄物用主送り歯	1
19	* #11	401-07504	THROAT PLATE 6.4MM GAUGE	薄物用針板 (1/4)	1
20	* #11	401-07505	THROAT PLATE 7.2MM GAUGE	薄物用針板 (9/32)	1
		NOTE(注記)	#01...FOR MS-3580 SF/1 Δ N	MS-3580 SF/1 Δ N 用	
			#02...FOR MS-3580 SG/1 Δ N	MS-3580 SG/1 Δ N 用	
			#03...FOR MS-3580 SF/0 Δ N	MS-3580 SF/0 Δ N 用	
			#04...FOR MS-3580 SG/0 Δ N	MS-3580 SG/0 Δ N 用	
			#05...FOR MS-3580 S Δ /1 Δ N	MS-3580 S Δ /1 Δ N 用	
			#06...FOR MS-3580 S Δ /0 Δ N	MS-3580 S Δ /0 Δ N 用	
			#07...FOR MS-3580 SF/ Δ Δ N	MS-3580 SF/ Δ Δ N 用	
			#08...FOR MS-3580 SG/ Δ Δ N	MS-3580 SG/ Δ Δ N 用	
			#09...FOR MS-3580 S Δ /1 Δ N	MS-3580 S Δ /1 Δ N 用	
			OPTIONAL PARTS		
			#10...FOR MS-3580 S Δ /0 Δ N	MS-3580 S Δ /0 Δ N 用	
			OPTIONAL PARTS		
			#11...OPTIONAL PARTS	オプション部品	

### 13. THREAD STAND COMPONENTS

糸立て装置関係

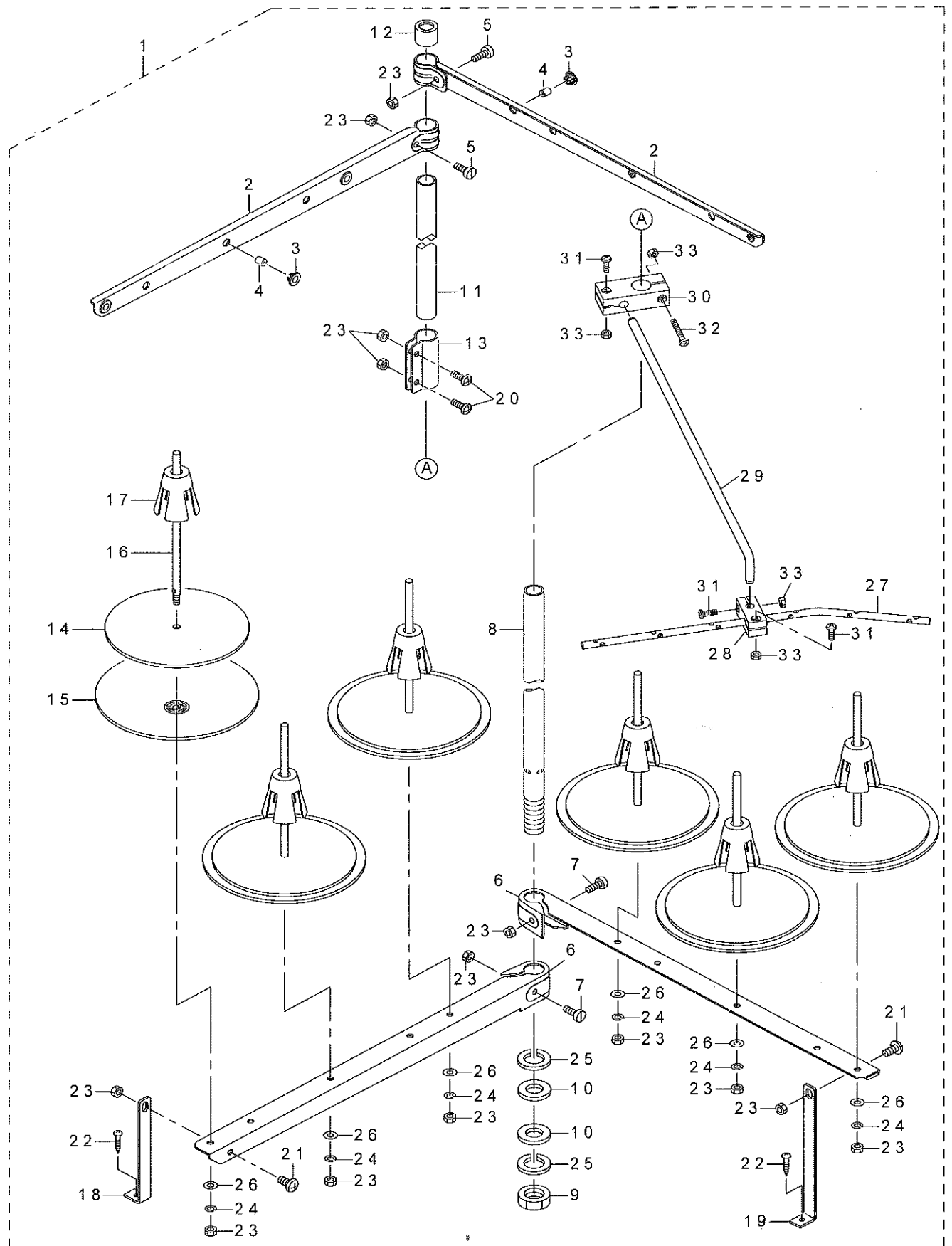

REF.NO	NOTE	PART NO	DESCRIPTION	品名	Qty
1	*	401-06586	THREAD STAND PACKING	糸立装置梱包図 (3本針インター)	1
2		401-06575	SPOOL REST LONG ARM UPPER	糸立糸案内 (長)	(2)
3		400-85795	THREAD GUIDE BUSHING	糸道ブッシュ	(6)
4		400-85794	THREAD GUIDE	糸道	(6)
5		400-96327	SPOOL REST ARM UPPER SCREW	糸立腕 (上) 止めねじ	(2)
6		401-06574	SPOOL REST LONG ARM LOWER	糸立腕下 (長)	(2)
7		400-96326	SPOOL REST ARM LOWER SCREW	糸立腕 (下) 止めねじ	(2)
8		400-85784	SPOOL REST ROD LOWER	糸立棒 (下)	(1)
9		400-96325	SPOOL REST ROD NUT	糸立棒止ナット	(1)
10		400-85796	SPOOL REST ROD RUBBER CUSHION	糸立棒防振ゴム	(2)
11		400-85785	SPOOL REST ROD UPPER	糸立棒 (上)	(1)
12		400-85793	SPOOL REST ROD RUBBER CAP	糸立棒保護キャップ	(1)
13		400-85792	SPOOL REST ROD JOINT	糸立棒継手	(1)
14		400-85789	SPOOL REST CUSHION	糸巻受皿クッション	(6)
15		400-85788	SPOOL REST	糸巻受皿	(6)
16		400-85790	SPOOL PIN	糸巻受棒	(6)
17		400-85791	SPOOL RETAINER	糸巻振り止め	(6)
18		401-06577	SPOOL REST ARM LOWER A	糸立腕支え (A)	(1)
19		401-06578	SPOOL REST ARM LOWER B	糸立腕支え (B)	(1)
20		SM-4051405-SE	SCREW M5 L=14	なべ小ねじ M5 L=14	(2)
21		SM-4051001-SE	SCREW M5 L=10	なべ小ねじ M5 X 0.8 L=10	(2)
22		SK-3412001-SE	WOOD SCREW D=4.1 L=20	丸木ねじ D=4.1 L=20	(2)
23		NM-6050001-SE	NUT M5X0.8 TYPE1	六角ナット M5 X 0.8 1種	(14)
24		WP-0531001-SC	WASHER M5	平座金みがき丸 M5	(6)
25		WP-1612616-SE	WASHER 16X30X2.6	平座金	(2)
26		WS-0510002-KN	SPRING WASHER M5	ばね座金 M5	(6)
27		401-06583	THREAD GUIDE 6	糸立糸案内下 (6本糸)	(1)
28		401-06580	THREAD GUIDE UNDER BASE	糸立糸案内下台	(1)
29		401-06576	THREAD GUIDE ARM	糸立糸案内腕	(1)
30		401-06579	THREAD GUIDE ARM BASE	糸立糸案内腕台	(1)
31		SM-4041201-SC	SCREW M4X0.7 L=12	なべ小ねじ M4 X 0.7 L=12	(3)
32		SM-4042501-SC	SCREW M4X0.7 L=25	なべ小ねじ M4 X 0.7 L=25	(1)
33		NM-6040002-SC	NUT M4X0.7 TYPE2	六角ナット M4 X 0.7 2種	(4)

# 14. ACCESSORIES PARTS COMPONENTS

付属品関係

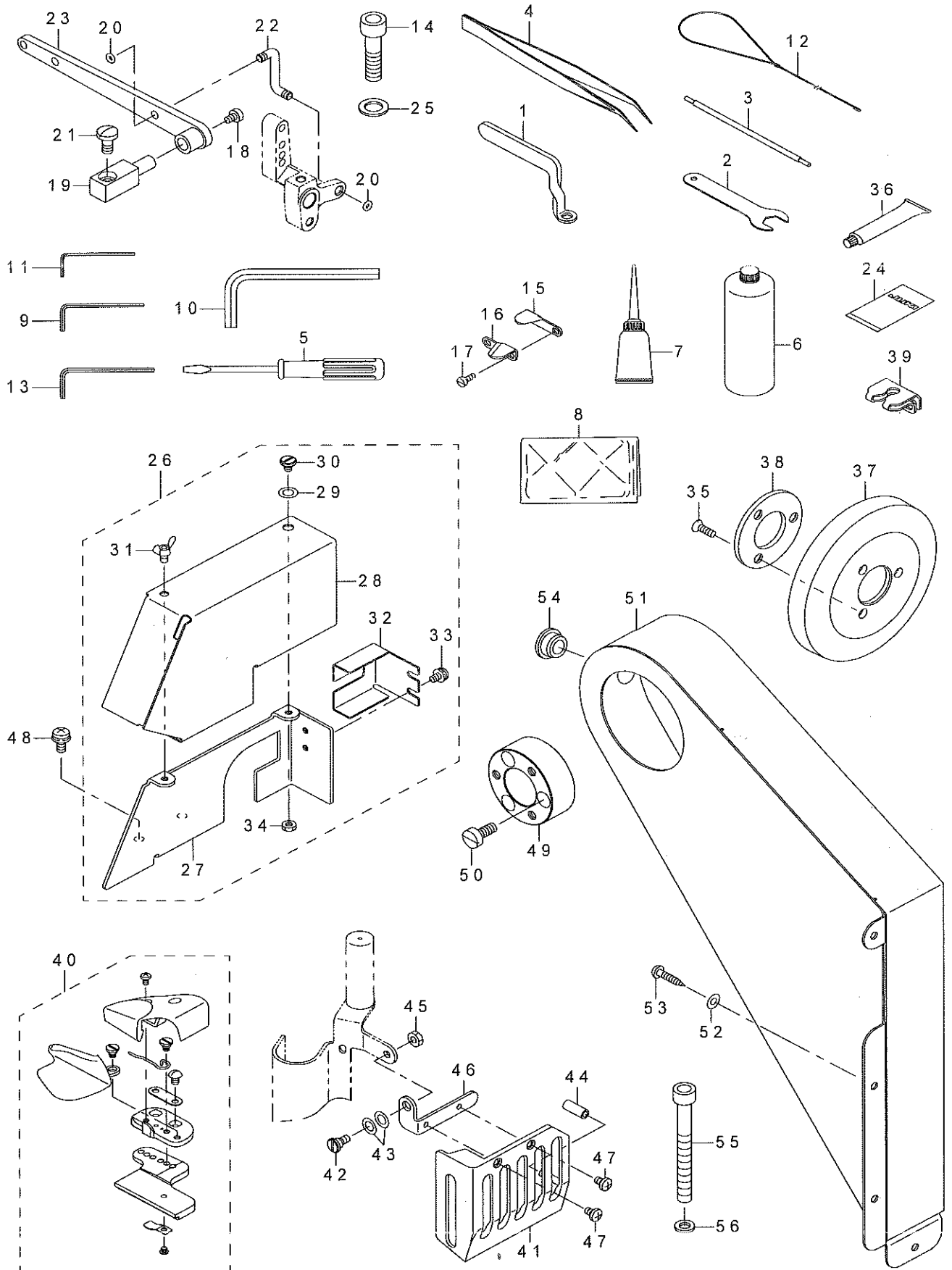

REF.NO	NOTE	PART NO	DESCRIPTION	品名	Qty
1		400-68617	WRENCH FOR LOOPER AVOID	レンチ	1
2		400-67303	SPANNER FOR FEED BAR	送り棒用レンチ	1
3		400-68618	NEEDLE HEAD TORQUE ROD	針棒ピンレンチ	1
4		122-88403	TWEEZERS	ピンセット	1
5		229-33105	SCREW DRIVER MIDDLE	ドライバー (中)	1
6		MML-018900CA	JUKI MACHINE OIL 18	JUKI MACHINE OIL 18	1
7		B9121-012-0A0	OILER ASM.	油さし組	1
8		400-66644	HEAD COVER	頭部カバー (大)	1
9		J1066-000-00C	HEXAGONAL WRENCH KEY 2.5	六角棒スパナ 2.5	1
10		G5407-161-000	HEXAGONAL ROD SPANNER	六角棒スパナ	1
11		J1066-000-00B	HEXAGONAL WRENCH KEY (2MM)	六角棒スパナ 2MM	1
12		140-58002	THREADER	糸通し	1
13		J1066-000-00D	HEXAGONAL WRENCH KEY	六角棒スパナ	1
14		SM-6103502-TP	SCREW M10 L=35	六角穴ボルト M10 L=35	2
15		400-68380	CHAIN CUTTER BLADE LOWER	下糸切りメス	1
16		400-68381	CHAIN CUTTER BLADE UPPER	上糸切りメス	1
17		SS-6080810-SP	SCREW 1/8-44 L=8.0	平ねじ 1/8-44 L=8	2
18		SS-6110630-TP	SCREW 11/64-40 L=6	平ねじ 11/64-40 L=6	1
19		400-67236	PRESSER FOOT LIFTER BEARING BRACKET	押え上げベアリングブラケット	1
20		RO-0291801-00	RUBBER RING	Oリング	2
21		SS-7151210-SP	SCREW 15/64-28 L=12	丸平ねじ 15/64-28 L=12	1
22		400-67238	LIFTER LEVER CONNECTING LINK	上げレバー連結リンク	1
23		400-67239	PRESSER FOOT CONNECTING LIFTER	押え連結上げレバー	1
24		MUY-130B140T	NEEDLE UY130GS NM140-10	針 UY130GS NM140-10	1
25		WP-1051416-SD	WASHER 10.5X17X1.4	平座金 10.5X17X1.4	2
26		400-73359	ROLLER COVER ASM.	上送りローラーカバー組	1
27		400-72763	COVER A	カバー A	(1)
28		400-73358	COVER B	カバー B	(1)
29		WZ-0641510-KP	WAVED WASHER 6.4X11X0.3	波形座金 6.4X11X0.3	(1)
30		400-81945	SHOULDER SCREW	段ねじ	(1)
31		163-68508	WING BOLT	蝶ボルト	(1)
32		400-73806	SAFETY COVER	安全カバー	(1)
33		SL-4040891-SC	SCREW M4 L=8	座金付きなべ小ねじ M4 L=8	(2)
34		NM-6040003-SC	NUT M4	六角ナット M4	(1)
35		SS-1151310-TP	SCREW	皿ねじ	3
36		400-13640	JUKI GREASE_B_TUBE	JUKI グリース B	1
37		400-68588	HANDWHEEL	はずみ車	1
38		400-68589	CLAMP PLATE	プーリー押え板	1
39		400-75567	CHAIN CUTTER COVER	メスカバー	1
40		400-66942	FOLDER ASSEMBLY 3.2MM	三巻フォルダー組 (3.2mm)	1
41		400-67087	SEWING GUARD	天秤カバー	1
42		SD-0640326-TP	HINGE SCREW	段ねじ	1
43		WZ-0641510-KP	WAVED WASHER 6.4X11X0.3	波形座金 6.4X11X0.3	2
44		BT-0600400-EC	TUBE HOSE, BLUE	ウレタンホース 青	0.015
45		NS-6110350-SP	NUT 11/64-40	六角ナット 11/64-40	1
46		400-81665	SEWING GUARD	天秤カバー台	1
47		SS-7090611-SL	SCREW 9/64-40 L=6.1	丸平ねじ 9/64-40 L=6.1	2
48		SL-4051291-SC	SCREW M5X0.8 L=12	なべ小ねじセムス M5X0.8 L=12	2
49		400-83674	BELT COVER SPACER	ベルトカバー スペース	1
50		SS-6151440-SP	SCREW 15/64-28 L=14	平ねじ 15/64-28 L=14	3
51		400-83683	BELT COVER	ベルト下カバー	1
52		WP-0450826-SC	WASHER 4.5X10X0.8	平座金 4.5X10X0.8	4
53		SK-3412001-SE	WOOD SCREW D=4.1 L=20	金取付けビス	4
54		TA-1470704-R0	RUBBER PLUG	止め栓	1
55		SM-6087002-TN	SCREW M8 L=70	六角穴ボルト M8 L=70	4
56		WP-0841600-SC	WASHER	平座金	4



NUMERICAL INDEX OF PARTS

索引

PART NO 品番	PAGE 頁	REF NO	PART NO 品番	PAGE 頁	REF NO	PART NO 品番	PAGE 頁	REF NO	PART NO 品番	PAGE 頁	REF NO
BT-0500300-EA	10	58	SL-4051291-SC	28	48	SS-6090630-TP	20	52	WP-0951016-SP	6	34
BT-0600400-EC	28	44	SM-1040950-TP	6	33	SS-6090670-TP	4	5	WP-0951016-SP	22	35
B1132-521-000	8	26	SM-4040855-SP	10	13	SS-6110610-TP	2	69	WP-1051416-SD	28	25
B1444-180-00B	2	38	SM-4041201-SC	26	31	SS-6110610-TP	2	74	WP-1612616-SE	26	25
B3538-112-000	10	51	SM-4041255-SP	2	15	SS-6110610-TP	2	80	WS-0310002-UZ	4	18
B9121-012-0A0	28	7	SM-4042501-SC	26	32	SS-6110610-TP	12	4	WS-0310002-UZ	6	4
			SM-4051001-SE	26	21	SS-6110630-TP	28	18	WS-0510002-KN	26	26
CM-3002000-01	2	81	SM-4051405-SE	26	20	SS-6110650-TP	10	37	WZ-0641510-KP	28	29
CM-3012000-01	2	73	SM-5030655-SP	2	9	SS-6110710-TP	14	11	WZ-0641510-KP	28	43
CM-5003000-01	2	82	SM-6030650-TP	20	16	SS-6111010-TP	2	31			
CM-6001001-01	2	29	SM-6030650-TP	20	84	SS-6111010-TP	14	1	101-29104	8	27
CQ-2000000-00	2	54	SM-6030850-TP	10	48	SS-6111010-TP	14	7	118-56101	14	13
CQ-2000000-00	4	41	SM-6041202-TP	18	34	SS-6111620-SP	12	1	122-88403	28	4
CQ-2000000-00	10	2	SM-6050660-TP	2	25	SS-6120940-SP	20	50	131-70105	2	24
CQ-2000000-00	10	16	SM-6050660-TP	10	61	SS-6121010-SP	8	13	131-70105	4	35
CQ-2000000-00	12	47	SM-6050800-SP	2	18	SS-6151440-SP	28	50	131-71004	2	23
CQ-2000000-00	14	50	SM-6051202-TP	16	33	SS-7090510-SP	6	49	131-71004	4	36
CQ-3030000-00	2	26	SM-6051202-TP	20	72	SS-7090520-TP	6	57	140-58002	28	12
CQ-3030000-00	10	41	SM-6062002-TP	8	11	SS-7090530-SP	22	53	163-66508	28	31
			SM-6063002-TP	2	27	SS-7090611-SL	28	47			
EA-9500B00-00	10	30	SM-6087002-TN	28	55	SS-7090710-SP	2	30	229-24708	2	5
			SM-6103502-TP	28	14	SS-7090710-SP	4	45	229-33105	28	5
G5407-161-000	28	10	SM-7030450-SC	20	43	SS-7090710-SP	6	50			
			SM-8030602-TP	20	12	SS-7090850-SP	2	87	400-09014	2	10
J1066-000-00B	28	11	SM-8030602-TP	20	93	SS-7091110-TP	8	29	400-09520	2	66
J1066-000-00C	28	9	SM-80404A2-TP	14	9	SS-7110540-SP	20	31	400-13640	28	36
J1066-000-00D	28	13	SM-80404A2-TP	16	44	SS-7110840-SP	2	77	400-66644	28	8
			SM-8040642-TP	16	43	SS-7111110-TP	12	29	400-66849	2	2
MML-018900CA	28	6	SM-8050612-TP	20	15	SS-7111120-TP	10	44	400-66851	2	6
MUY-130B140T	28	24	SM-8050612-TP	20	90	SS-7111410-TP	6	10	400-66854	2	7
MUY-130B1400	24	12	SM-8050612-TP	22	15	SS-7111410-TP	6	59	400-66855	2	8
			SM-8050812-TP	10	25	SS-7121410-TP	2	36	400-66857	2	12
NM-6040002-SC	26	33	SM-8050812-TP	10	28	SS-7121410-TP	8	15	400-66864	2	16
NM-6040003-SC	28	34	SM-8061010-TP	12	9	SS-7151210-SP	28	21	400-66865	2	20
NM-6050001-SE	26	23	SS-1090520-TP	2	65	SS-8080310-TP	12	17	400-66866	2	21
NM-6050001-SP	12	41	SS-1090750-SP	22	2	SS-8080310-TP	12	28	400-66875	2	33
NM-6050001-SP	14	21	SS-1090930-SP	8	22	SS-8110410-TP	10	20	400-66876	2	37
NM-6050001-SP	16	15	SS-1090930-SP	8	38	SS-8110422-TP	20	14	400-66878	2	39
NM-6050001-SP	16	31	SS-1090930-SP	22	49	SS-8110422-TP	20	94	400-66880	2	41
NM-6050001-SP	22	31	SS-1110840-SP	16	35	SS-8110422-TP	22	8	400-66881	2	42
NM-6060003-SP	20	78	SS-1110840-SP	18	39	SS-8110422-TP	24	2	400-66882	2	44
NS-6090310-SP	2	40	SS-1151310-TP	28	35	SS-8110432-SP	12	35	400-66884	2	51
NS-6090310-SP	2	89	SS-2080810-SP	4	25	SS-8110432-SP	18	23	400-66890	2	85
NS-6110310-SP	8	19	SS-2090710-TP	12	3	SS-8110520-TP	4	9	400-66891	2	55
NS-6110350-SP	2	35	SS-2090810-SP	6	61	SS-8110520-TP	8	10	400-66892	2	56
NS-6110350-SP	28	45	SS-4060310-SP	4	12	SS-8110710-SP	4	23	400-66893	2	57
NS-6120630-SP	22	57	SS-4080515-SP	2	19	SS-8110710-SP	4	31	400-66894	2	58
NS-6150350-SP	8	7	SS-4080515-SP	14	28	SS-8110710-SP	6	17	400-66895	2	59
NS-6150430-SP	22	1	SS-4080620-TP	4	24	SS-8110710-SP	6	23	400-66896	2	60
NS-6150430-SP	22	32	SS-4080620-TP	6	16	SS-8110710-SP	6	41	400-66898	2	62
NS-6660430-SP	12	32	SS-4080620-TP	8	39	SS-8110710-SP	6	53	400-66899	2	63
NS-6660430-SP	16	38	SS-4080620-TP	10	38	SS-8110710-SP	18	33	400-66902	2	67
NS-6660430-SP	16	40	SS-4090715-SP	20	3	SS-8150822-TP	20	38	400-66903	2	68
NS-6660430-SP	18	14	SS-4091015-SP	8	17	SS-8150822-TP	22	5	400-66905	2	76
NS-6660430-SP	22	16	SS-4111015-SP	2	83	SS-8660612-TP	2	46	400-66906	2	78
NS-6700320-SP	22	58	SS-4111215-SP	2	1	SS-9151160-CP	20	49	400-66909	4	1
			SS-5090610-SP	4	30				400-66909	6	40
PS-0200182-KP	22	39	SS-5090610-SP	6	35	TA-1470704-R0	28	54	400-66911	4	2
PS-0400202-KP	20	42	SS-6060510-TP	22	41	TA-2050406-R0	4	39	400-66912	4	3
			SS-6080410-SP	8	33				400-66912	6	43
RO-0291801-00	28	20	SS-6080720-SP	10	47	WP-0330500-MB	6	8	400-66913	4	4
RO-0611801-00	6	32	SS-6080810-SP	14	15	WP-0370316-SD	2	88	400-66914	4	14
RO-0611801-00	14	23	SS-6080810-SP	28	17	WP-0380516-SD	20	1	400-66915	4	15
RO-0611801-00	16	37	SS-6090420-SP	2	34	WP-0450801-SP	2	79	400-66916	4	16
RO-0981901-00	6	47	SS-6090440-SP	4	40	WP-0450826-SC	28	52	400-66917	4	20
RO-1482402-00	2	4	SS-6090440-SP	6	20	WP-0480856-SP	2	52	400-66917	6	11
RO-1482402-00	2	14	SS-6090440-SP	8	35	WP-0531001-SC	26	24	400-66918	4	21
			SS-6090440-SP	22	56	WP-0621026-SP	22	33	400-66918	6	54
SB-1200022-00	2	47	SS-6090510-TP	10	45	WP-0621026-SP	22	38	400-66919	4	22
SD-0380551-SL	8	25	SS-6090510-TP	18	2	WP-0651056-SD	2	28	400-66919	6	12
SD-0640326-TP	28	42	SS-6090510-TP	18	5	WP-0651056-SD	8	48	400-66920	4	6
SK-3412001-SE	26	22	SS-6090510-TP	18	8	WP-0651056-SH	22	18	400-66920	6	15
SK-3412001-SE	28	53	SS-6090610-SP	8	28	WP-0700616-SP	16	41	400-66923	4	7
SL-4040881-SC	10	52	SS-6090620-TP	20	33	WP-0740516-SP	8	47	400-66924	4	27
SL-4040891-SC	28	33	SS-6090630-TP	10	7	WP-0841600-SC	28	56	400-66925	4	28



NUMERICAL INDEX OF PARTS

索引

PART NO 品番	PAGE 頁	REF NO	PART NO 品番	PAGE 頁	REF NO	PART NO 品番	PAGE 頁	REF NO	PART NO 品番	PAGE 頁	REF NO
400-66927	4	32	400-67180	16	21	400-68299	18	12	400-68470	14	24
400-66928	4	33	400-67181	16	24	400-68300	16	12	400-68471	16	1
400-66928	6	22	400-67181	18	28	400-68300	18	11	400-68471	18	4
400-66929	4	34	400-67183	16	22	400-68302	18	29	400-68472	16	4
400-66929	6	21	400-67183	18	31	400-68303	18	41	400-68472	18	7
400-66942	28	40	400-67184	16	19	400-68304	20	36	400-68473	16	7
400-66969	4	44	400-67184	18	24	400-68305	20	48	400-68473	18	1
400-66969	6	39	400-67196	16	42	400-68306	22	37	400-68474	16	14
400-66975	4	47	400-67200	18	15	400-68311	10	42	400-68522	16	18
400-66996	6	62	400-67201	18	27	400-68312	10	36	400-68525	16	20
400-66998	6	2	400-67202	18	32	400-68335	2	11	400-68531	16	34
400-67001	6	6	400-67203	18	38	400-68341	2	17	400-68531	18	40
400-67003	6	13	400-67207	20	2	400-68345	2	22	400-68532	16	36
400-67008	6	25	400-67209	20	10	400-68368	2	43	400-68534	16	39
400-67009	6	26	400-67213	20	28	400-68371	2	48	400-68535	16	45
400-67013	4	29	400-67213	20	82	400-68376	2	71	400-68536	16	25
400-67013	6	36	400-67217	20	77	400-68377	10	43	400-68537	16	26
400-67014	6	37	400-67218	20	34	400-68378	2	84	400-68538	16	29
400-67050	6	42	400-67220	20	96	400-68380	28	15	400-68539	16	27
400-67051	6	48	400-67221	20	44	400-68381	28	16	400-68540	16	30
400-67054	6	58	400-67223	20	71	400-68382	4	11	400-68542	22	25
400-67055	6	44	400-67224	20	46	400-68383	4	19	400-68543	18	13
400-67059	6	60	400-67225	20	47	400-68384	4	26	400-68545	18	19
400-67073	8	3	400-67226	20	51	400-68384	6	14	400-68546	18	21
400-67074	8	4	400-67227	20	55	400-68386	4	37	400-68554	20	5
400-67075	20	39	400-67227	20	65	400-68389	6	63	400-68555	20	6
400-67078	8	8	400-67228	20	58	400-68391	6	18	400-68556	20	8
400-67082	8	23	400-67228	20	68	400-68392	6	27	400-68558	20	13
400-67087	28	41	400-67229	20	59	400-68395	6	55	400-68558	20	91
400-67089	20	9	400-67230	20	61	400-68397	8	14	400-68559	20	17
400-67090	8	32	400-67230	20	70	400-68398	8	16	400-68559	20	85
400-67091	8	24	400-67231	20	62	400-68399	8	20	400-68560	20	18
400-67092	8	41	400-67232	20	73	400-68401	8	31	400-68560	20	92
400-67093	8	42	400-67233	20	74	400-68402	8	34	400-68561	20	19
400-67094	8	45	400-67234	20	75	400-68403	8	36	400-68561	20	87
400-67100	10	3	400-67235	20	76	400-68405	8	40	400-68562	20	20
400-67101	10	4	400-67236	28	19	400-68409	8	30	400-68562	20	88
400-67102	10	6	400-67238	28	22	400-68410	10	1	400-68563	20	29
400-67109	10	10	400-67239	28	23	400-68413	10	5	400-68563	20	89
400-67118	10	14	400-67240	22	14	400-68419	10	8	400-68564	20	22
400-67119	10	32	400-67241	22	12	400-68420	10	9	400-68565	20	23
400-67120	10	33	400-67242	22	3	400-68421	10	18	400-68566	20	24
400-67121	10	15	400-67243	22	4	400-68422	10	21	400-68566	20	83
400-67124	10	19	400-67244	22	36	400-68423	10	26	400-68568	20	26
400-67125	10	34	400-67245	22	29	400-68424	10	24	400-68572	20	7
400-67132	10	39	400-67249	2	72	400-68425	10	27	400-68573	20	32
400-67133	10	40	400-67272	22	40	400-68426	10	11	400-68574	20	37
400-67134	12	2	400-67273	22	44	400-68427	10	49	400-68575	20	41
400-67137	12	11	400-67274	22	43	400-68429	10	46	400-68576	20	53
400-67138	12	12	400-67275	22	50	400-68430	12	5	400-68577	20	56
400-67139	12	14	400-67276	22	46	400-68430	14	6	400-68577	20	66
400-67140	12	15	400-67281	22	51	400-68431	12	10	400-68578	20	57
400-67141	12	16	400-67282	22	52	400-68432	12	13	400-68578	20	67
400-67142	12	20	400-67283	22	55	400-68433	12	19	400-68579	20	64
400-67144	12	23	400-67284	22	6	400-68434	12	22	400-68580	20	60
400-67145	12	24	400-67285	22	7	400-68435	12	25	400-68580	20	69
400-67147	12	31	400-67286	24	1	400-68436	12	34	400-68581	22	9
400-67148	12	33	400-67287	24	3	400-68438	12	39	400-68582	22	17
400-67149	14	16	400-67289	24	6	400-68439	12	40	400-68583	22	13
400-67154	12	46	400-67290	24	13	400-68441	12	42	400-68584	22	11
400-67155	14	22	400-67292	24	7	400-68444	12	37	400-68585	22	10
400-67155	18	20	400-67293	24	14	400-68448	6	46	400-68588	28	37
400-67156	14	12	400-67295	24	8	400-68449	12	45	400-68589	28	38
400-67161	14	27	400-67297	24	10	400-68451	14	10	400-68591	22	27
400-67161	18	25	400-67298	24	15	400-68452	14	14	400-68592	22	24
400-67166	14	30	400-67303	28	2	400-68455	14	20	400-68593	22	26
400-67167	14	31	400-68293	8	12	400-68456	14	18	400-68594	22	20
400-67168	14	36	400-68294	8	9	400-68461	14	17	400-68595	22	21
400-67169	14	38	400-68295	10	31	400-68463	14	29	400-68596	22	22
400-67172	14	48	400-68296	12	7	400-68465	14	33	400-68598	22	48
400-67172	18	18	400-68296	14	4	400-68466	14	34	400-68599	22	60
400-67173	14	49	400-68297	14	47	400-68466	18	17	400-68600	22	42
400-67174	14	2	400-68298	16	10	400-68467	14	39	400-68601	10	22
400-67176	16	13	400-68298	18	10	400-68468	14	41	400-68601	22	45
400-67179	16	16	400-68299	16	11	400-68469	14	44	400-68602	22	47

NUMERICAL INDEX OF PARTS

索引

PART NO 品番	PAGE 頁	REF NO	PART NO 品番	PAGE 頁	REF NO	PART NO 品番	PAGE 頁	REF NO	PART NO 品番	PAGE 頁	REF NO
400-68603	22	54	400-70191	14	37	401-06574	26	6			
400-68612	24	11	400-70192	14	32	401-06575	26	2			
400-68617	28	1	400-70193	24	5	401-06576	26	29			
400-68618	28	3	400-70194	24	4	401-06577	26	18			
400-68645	2	49	400-70319	4	13	401-06578	26	19			
400-68656	8	44	400-70346	6	19	401-06579	26	30			
400-68663	14	42	400-70350	4	38	401-06580	26	28			
400-68663	14	46	400-70353	10	23	401-06583	26	27			
400-68664	14	43	400-70491	20	79	401-06586	26	1			
400-68664	14	45	400-72348	2	13	401-07500	24	16			
400-68794	12	6	400-72351	10	50	401-07501	24	17			
400-68794	12	8	400-72763	28	27	401-07503	24	18			
400-68794	14	3	400-73130	2	66	401-07504	24	19			
400-68794	14	5	400-73358	28	28	401-07505	24	20			
400-68816	16	23	400-73359	28	26	401-12855	2	45			
400-68817	16	3	400-73806	28	32	401-12856	2	61			
400-68817	16	6	400-73864	20	25	401-12857	4	43			
400-68817	16	9	400-73864	20	95	401-12857	6	38			
400-68817	18	3	400-74648	6	24	401-12858	10	17			
400-68817	18	6	400-74649	6	28	401-18632	20	86			
400-68817	18	9	400-74653	6	29	401-20356	20	80			
400-68828	22	19	400-74654	6	30						
400-68921	10	29	400-74655	6	31						
400-69015	14	40	400-74663	16	32						
400-69085	14	25	400-75055	16	2						
400-69128	16	17	400-75055	16	5						
400-69128	16	28	400-75055	16	8						
400-69128	22	30	400-75304	10	53						
400-69155	12	26	400-75305	10	54						
400-69453	12	21	400-75306	10	55						
400-69453	12	30	400-75307	10	56						
400-69460	22	34	400-75567	28	39						
400-69753	12	18	400-76293	14	35						
400-69768	8	37	400-76293	18	16						
400-69771	12	38	400-76295	14	8						
400-69771	12	43	400-76295	18	30						
400-69771	22	23	400-77682	20	27						
400-69771	22	28	400-77683	20	11						
400-69776	18	36	400-78404	8	18						
400-69777	18	37	400-78404	10	57						
400-69800	8	46	400-78418	20	35						
400-69840	20	54	400-81665	28	46						
400-69841	20	63	400-81693	10	35						
400-69882	6	56	400-81945	28	30						
400-69883	4	17	400-81999	22	61						
400-69883	6	5	400-82003	6	52						
400-69884	4	10	400-82006	4	46						
400-69884	6	1	400-82015	22	59						
400-69886	12	36	400-82705	8	5						
400-69886	18	22	400-82711	8	2						
400-69918	12	44	400-82712	8	6						
400-69918	14	19	400-82824	10	59						
400-69919	6	7	400-82833	10	60						
400-69920	6	3	400-82960	8	43						
400-69921	6	9	400-83065	2	75						
400-69957	2	70	400-83674	28	49						
400-69985	20	40	400-83683	28	51						
400-69993	4	8	400-84993	20	21						
400-69994	6	45	400-84993	20	81						
400-70015	2	50	400-85784	26	8						
400-70054	24	9	400-85785	26	11						
400-70082	2	32	400-85788	26	15						
400-70071	4	42	400-85789	26	14						
400-70071	6	51	400-85790	26	16						
400-70073	14	26	400-85791	26	17						
400-70073	18	26	400-85792	26	13						
400-70075	2	53	400-85793	26	12						
400-70093	18	35	400-85794	26	4						
400-70102	2	3	400-85795	26	3						
400-70141	8	21	400-85796	26	10						
400-70157	2	64	400-96325	26	9						
400-70158	8	1	400-96326	26	7						
400-70175	20	4	400-96327	26	5						
400-70175	20	45	400-98071	10	12						
400-70177	20	30	401-02214	12	27						