

1. BUTTON CLAMP MECHANISM COMPONENTS

ボタンツマミ関係



Ref. No.	Note	Part No. 品番	Description	E. C. 変更年月	品名	Amt. Req. 数量
1		B2542-372-RA0	BUTTON CLAMP HOLDER ASM.		フイタヨ- ホックツマミソ-チ	1
2		B2546-372-0C0	BUTTON CLAMP LIFTING ROD		ツマミソ-チ ヒキアゲフツク	(1)
3		B2549-372-R00	CLAMP SCREW A		ヒラキレハ- トメネシ A	(1)
4		SD-0500301-SP	HINGE SCREW D= 5 H= 3		タ-ンネシ D=5 H=3	(1)
5		SS-7091480-SP	SCREW 9/64-40 L=14		タ-ンネシ D=3.6 H=8.5	(1)
6		GBR-01604000-A	CLAMP RELEASE LINK	D.07/80	クランプカ-シヨ リ-ク	-
6-1		GBR-01604000-B	CLAMP RELEASE LINK	A.07/80	クランプカ-シヨ リ-ク	(1)
7		GBR-01606000	RELEASE RETURN SPRING		カ-シヨ モトシハ-ネ	(1)
8		GBR-01607000	SPRING HOOK		スプリ-ク フツク	(2)
9		NS-6080210-CP	NUT 1/8-44	M.07/80	ロツカクナツト 1/8-44	(2)
9-1		NS-6120310-CP	NUT 3/16-28	A.07/80	ロツカクナツト 3/16-28	(1)
10		GBR-01605000	CLAMP RELEASE BRACKET SHAFT	D.07/80	カ-シヨ ヲクシ-ク	-
10-1		GBR-01605000-A	CLAMP RELEASE BRACKET SHAFT	A.07/80	カ-シヨ ヲクシ-ク	(1)
11		NS-6090310-SP	NUT 9/64-40		ロツカクナツト 9/64-40	(1)
12		GBR-01601000-A	CLAMP RELEASE LEVER		クランプカ-シヨ レハ-	(1)
13		B2548-372-RA0	BUTTON CLAMP STOP LEVER ASM.		ツマミアシ ヒラキレハ- 〇ミ	(1)
14		SS-9121340-CP	SCREW 3/16-28 L=13		ロツカクホ-ルト 3/16-28 L=13	(2)
15		SS-9150510-TP	SCREW 15/64-28 L= 4.7		トメネシ 15/64-28 L=4.7	(1)
16		WP-0501016-SP	WASHER 5X10.5X1		ヒラケカ-ネ	(2)
17		SD-0550301-SP	HINGE SCREW D=5.5 H=3		タ-ンネシ D=5.5 H=3	(1)
18		B2547-372-000	JAW LEVER HOLDER		ホ-ク ツマミアシ トリツクタイ	(1)
19		SS-7150940-SP	SCREW 15/64-28 L=9		マルヒラネシ 15/64-28 L=9	(1)
20		B2542-372-R00	BUTTON CLAMP HOLDER		ツマミソ-チ トリツクタイ	(1)
21		B2555-372-RA0	BUTTON CLAMP JAW LEVER, LEFT ASM.		ホ-クツマミアシ ホ-リ 〇ミ	(1)
21-1	#01	B2555-372-RAA	JAW LEVER, LEFT ASM.	A.05/83	ホ-クツマミアシ ホ-リ 〇ミ	(1)
22		B2555-372-R00	BUTTON CLAMP JAW LEVER, LEFT		ホ-ク ツマミアシ ホ-リ	(1)
22-1	#01	B2555-372-R0A	JAW LEVER, LEFT	A.05/83	ホ-クツマミアシ ホ-リ	(1)
23		B2556-372-R00	BUTTON CLAMP PLATE SPRING, LEFT		ホ-ク ツマミイタハ-ネ ホ-リ	(1)
23-1	#01	B2556-372-R0A	BUTTON CLAMP PLATE SPRING, LEFT	A.05/83	ホ-クツマミアシ イタハ-ネ ホ-リ	(1)
24		SS-7090520-TP	SCREW 9/64-40 L= 4.5		マルヒラネシ 9/64-40 L=4.5	(1)
25		B2559-372-000	BUTTON CLAMP LOCATING PIN		ツマミアシ イタハ-ネ カ-イト-セ-ン	(1)
26		B2557-372-RA0	BUTTON CLAMP JAW LEVER, RIGHT ASM.		ホ-クツマミアシ ミキ 〇ミ	(1)
26-1	#01	B2557-372-RAA	JAW LEVER, RIGHT ASM.	A.05/83	ホ-クツマミアシ ミキ 〇ミ	(1)
27		B2557-372-R00	BUTTON CLAMP JAW LEVER, RIGHT		ホ-ク ツマミアシ ミキ	(1)
27-1	#01	B2557-372-R0A	JAW LEVER, RIGHT	A.05/83	ホ-クツマミアシ ミキ	(1)
28		B2558-372-R00	BUTTON CLAMP PLATE SPRING, RIGHT		ホ-ク ツマミイタハ-ネ ホ-リ	(1)
29		SS-7090520-TP	SCREW 9/64-40 L= 4.5		マルヒラネシ 9/64-40 L=4.5	(1)
30		B2559-372-0C0	BUTTON CLAMP LOCATING PIN		ツマミアシ イタハ-ネ カ-イト-セ-ン	(1)
31		B2560-372-0C0	BUTTON CLAMP STOP PIN		ツマミアシ ヒラキセ-ン	(2)
32		SD-0640391-TP	HINGE SCREW D= 6.35 H= 3.9		タ-ンネシ D=6.35 H=3.9	(2)
33		B2561-372-0C0	BUTTON CLAMP SPRING		ホ-ク ツマミアシ ハ-ネ	(1)
34		B2552-372-R00	BUTTON CLAMP SLIDE GUIDE		ホ-ク カ-イト-アシ	(1)
35		B2553-372-0C0	NUT		ホ-ク カ-イト-アシ トメネシ B	(1)
36		GBR-01602000	SLIDE BRACKET		スライト-ウケイタ	(1)
37		SS-9091010-SP	SCREW 9/64-40 L=10		ロツカクホ-ルト 9/64-40 L=10	(2)
38		B2540-372-000	HINGE PIN		ツマミソ-チ トリツクシ-ク	1
39		B2541-372-000	SNAP RING		ツマミソ-チ トリツクシ-ク トメ	1
40		B2544-372-000	BUTTON CLAMP PRESSURE ADJUSTING BAR		ネジ アツリヨク クロ-セ-ンホ-	1
41		B2545-372-000	PRESSURE ADJUSTING SPRING		ネジ チョ-セツハ-ネ	1
42		B3175-012-0C0	THREAD TENSION STUD NUT		イトチヨ-シ ナツト	2
43		B4416-373-0C0	SPRING GUIDE SHAFT		ハ-スツクホ-	1
44		D9317-762-T00	GUIDE SHAFT SPRING		シ-ンヒモ アンナイシ-ク ハ-ネ	1
45		WP-0612056-SD	WASHER 6.1X18.5X2		ヒラケカ-ネ 6.1X18.5X2	2
46		B4470-373-0C0	CUSHION		シヤク-ン クツシヨク	1

Note (注記) #01 Special order part
(Small button)

特注部品(小ボタン用)



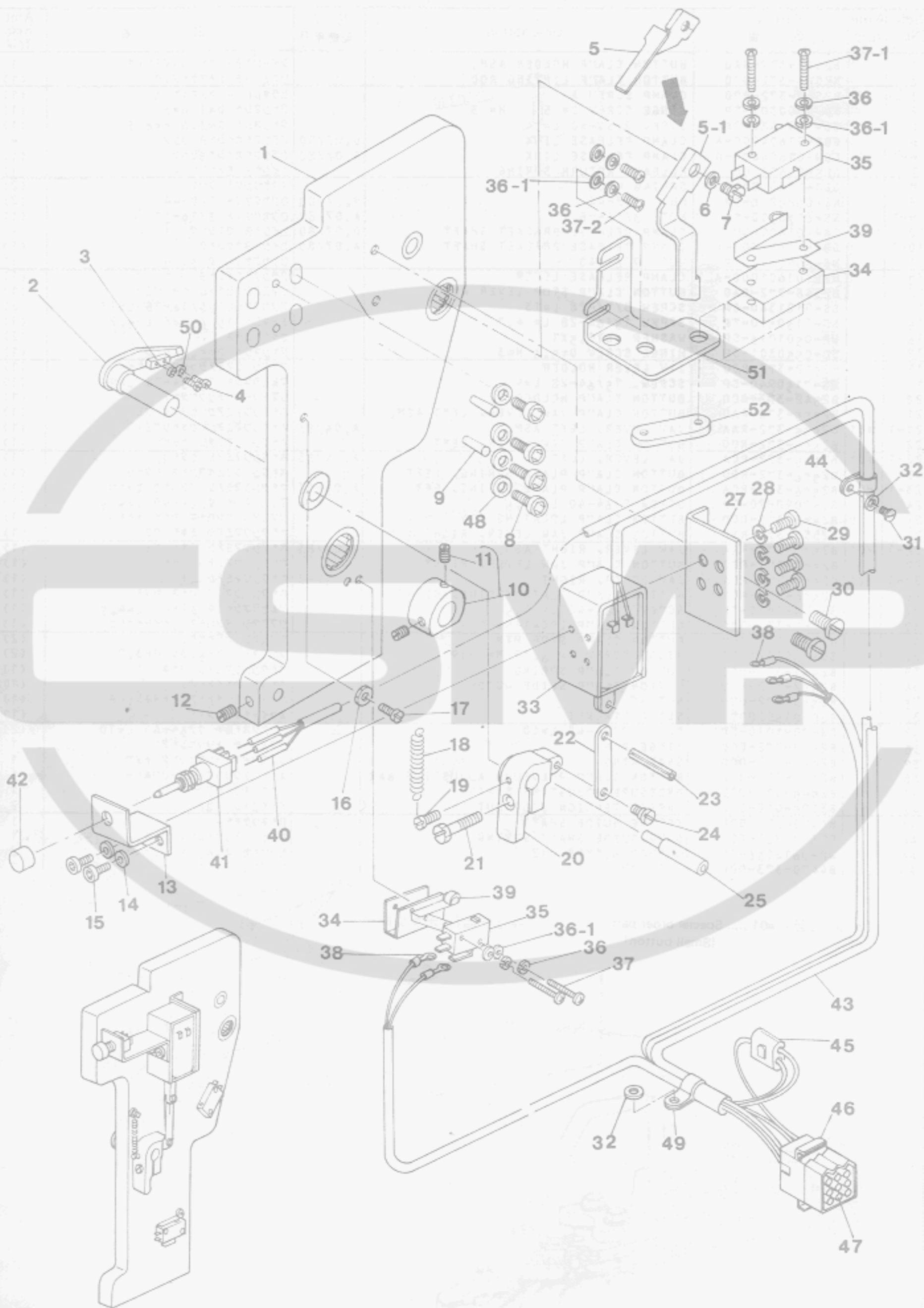

Ref. No.	Note	Part No. 品番	Description	E.C. 変更年月	品名	Amt. Req. 数量
1		GBR-011030A0	SIDE COVER 2 ASM.		カタイ カウイタ 2 クミ	1
2		GBR-012230A0-A	CLUTCH OPERATING LEVER ASM.		クラッチ サイトレバ - クミ	1
3		GBR-01222000	STOPPER		ストッパ -	1
4		SS-6090810-SP	SCREW 9/64-40 L=7.5		ヒラネジ 9/64-40 L=7.5	2
5	*	GBR-01231000	SWITCH OPERATING LEVER	D.01/86	スイッチ オペレバ -	-
5-1	*	GBR-01231000-A	SWITCH OPERATING LEVER	A.01/86	スイッチオプレバ -	1
6		WS-0610002-KN	SPRING WASHER 6.1X12.2X1.5		ハネワカネ M6	1
7		SS-9660720-SP	SCREW 1/4-40 L=7		ロツカクネルト 1/4-40 L=7	1
8		SM-6051802-SD	SCREW M5X0.8 L=18		ロツカクアサネルト M5X0.8 L=18	4
9		PT-0402000-CH	TAPERED PIN		テーパーピン 4X20	2
10		GBR-012200B0	THRUST SWITCH CAM ASM.		スラスト スイッチカム クミ	1
11		SS-8660512-TP	SCREW 1/4-40 L=5		トメネジ 1/4-40 L=5	(2)
12		SS-8660512-TP	SCREW 1/4-40 L=5		トメネジ 1/4-40 L=5	1
13		GBR-01238000	SWITCH MOUNTING PLATE		オシホタン スイッチトリツカイタ	1
14		WP-0330500-MB	WASHER 3.3X6X0.5		ヒラワカネ コカワタ M3	2
15		SM-4040601-SB	SCREW M4 L=6		ナハコネジ M4X0.7 L=6	2
16		NS-6120310-SP	NUT 3/16-28		ロツカクナツ 3/16-28	1
17		SS-6121010-SP	SCREW 3/16-28 L=10		ヒラネジ 3/16-28 L=10	1
18		GBR-01227000	TENSION SPRING		ヒツハリハネ	1
19		SS-6122030-SP	SCREW 3/16-28 L=20		ヒラネジ 3/16-28 L=20	1
20		GBR-01225000-A	SHAFT PLATE		シャフトオサエ	1
21		SS-9152130-CP	SCREW 15/64-28 L=20.5		ロツカクネルト 15/64-28	1
22		GBR-01229000-A	CLUTCH PLATE		クローイタ	1
23		PS-0400141-KH	SPRING PIN 4X14		スプリングピン 4X14	1
24		SD-0450211-SP	HINGE SCREW D=4.50 H=2.1		タムネジ D=4.5 H=2.1	1
25		GBR-01183000	REINFORCEMENT STUD B		ネキヨースタツ B	1
27		GBR-01221000	SOLENOID PLATE		ソレノイト オサエイタ	1
28		WS-0410002-KN	SPRING WASHER M4		ハネワカネ M4	4
29		SM-4040601-SB	SCREW M4 L=6		ナハコネジ M4X0.7 L=6	4
30		SS-6121010-SP	SCREW 3/16-28 L=10		ヒラネジ 3/16-28 L=10	2
31		SS-9091010-SP	SCREW 9/64-40 L=10		ロツカクネルト 9/64-40 L=10	1
32		WP-0450500-SA	WASHER M4		ヒラワカネ コカワタ M4	2
33		GBR-01240000-A	LOADER MAGNET		ローダ マグネツト	1
34		MAO-11602N00	MICRO-SWITCH COVER		スイッチカバー	2
35		GBR-01234000	MICRO-SWITCH		マイクロスイッチ	2
36	*	WS-0300002-KN	SPRING WASHER M3	D.01/86	WS-0310702-KS	-
	*	WS-0310702-KS	SPRING WASHER	A.01/86	ハネワカネ 3.1X5.9X0.7	6
36-1	*	WP-0330500-MB	WASHER 3.3X6X0.5	A.01/86	ヒラワカネ コカワタ M3	6
37	*	SM-4031601-SF	SCREW M3X0.5 L=16	M.01/86	ナハコネジ M3X0.5 L=16	2
37-1	*	SM-4031801-SB	SCREW M3X0.5 L=18	A.01/86	ナハコネジ M3X0.5 L=18	2
37-2	*	SM-4031001-SC	SCREW M3X0.5 L=10	A.01/86	ナハコネジ M3X0.5 L=10	2
38		GBR-01235000	SOLDERLESS TERMINAL		マイクロスイッチ アツチクワツシ	5
39	*	MAO-11514000	ACTUATOR	M.01/86	アクチエータ	2
40		BT-0300250-A0	TUBE ASM.		パイプチューブ	0.1
41		GBR-01236000	PUSHBUTTON SWITCH 8N-1021		オシホタン スイッチ	1
42		GBR-01237000	PUSH-BUTTON SWITCH CAP, RED		オシホタン	1
43		BT-0440330-Z0	INSULATED TUBE		ヒツエン チューブ D=3.3X4.4	0.9
44		D2120-555-C00	NYLON CLAMP		ナイロン クランプ	1
45		GBR-01233000	BRANCH CONNECTOR		シベン コネクタ	1
46		D6028-555-B0B	9-POLE RECEPTACLE, WHITE		9キヨク ナイロン レセプタクル(シロ)	1
47		D6043-555-B00	PIN TERMINAL, MALE		ピン ターミナル オス	9
48		WP-0501016-SC	WASHER 5X10.5X1		ヒラワカネ 5X10.5X1	4
49		MAZ-02508000	CORD HOLDER		コートヒキトメ	1
50		WS-0410002-KN	SPRING WASHER M4		ハネワカネ M4	2
51	*	GBR-01241000	SWITCH INSTALLING PLATE	A.01/86	マイクロスイッチトメク	1
52	*	GBR-01242000	NUT PLATE	A.01/86	マイクロスイッチトメナツト	1

3. BUTTON CARRIER COMPONENTS

ボタンキャリア関係

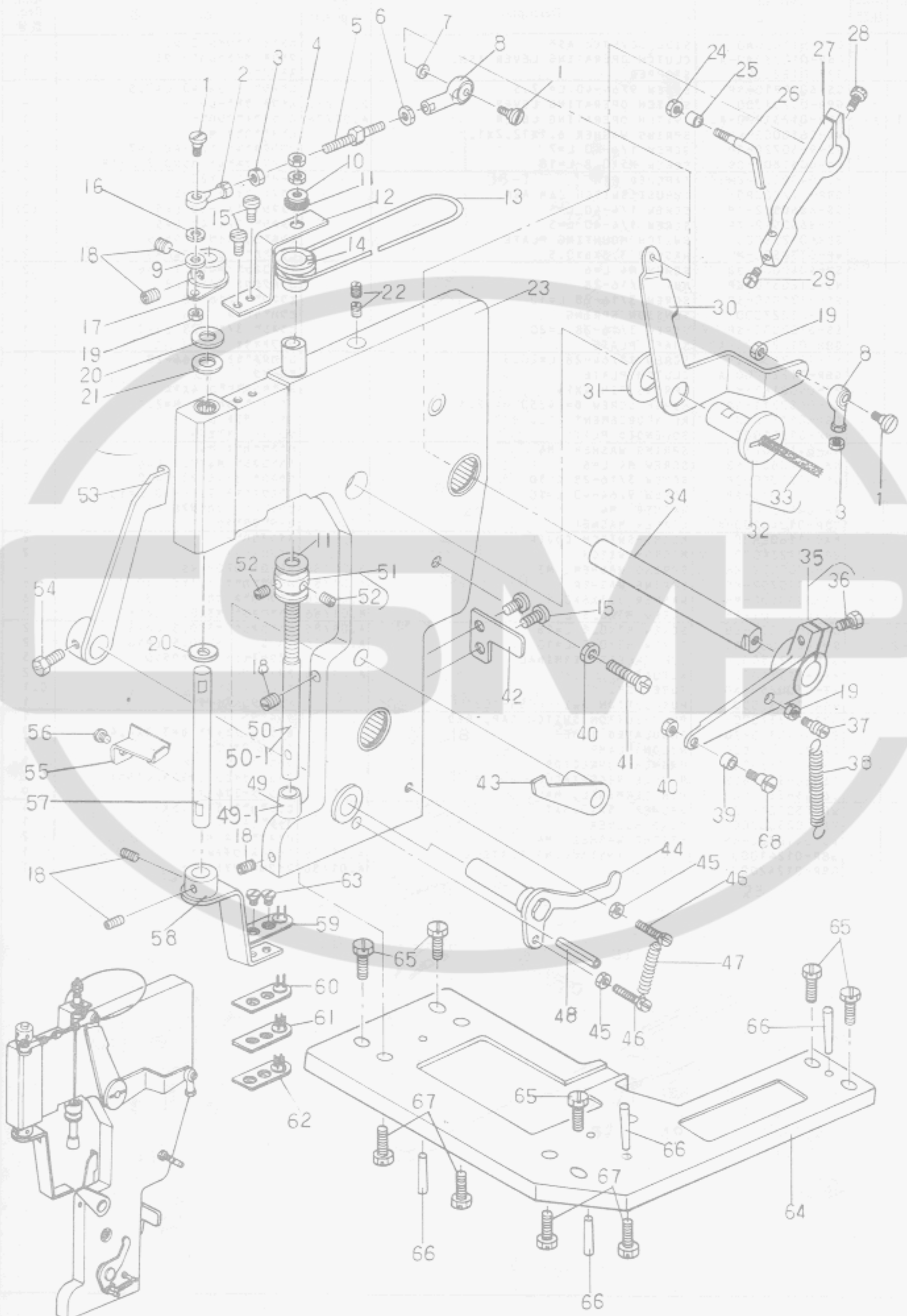

Ref. No.	Note	Part No. 品番	Description	E. C. 変更年月	品名	Amt. Req. 数量
1		GBR-01173000	SCREW		ロツクネツト	3
2		GBR-01170000	ROD END 1		ロツクネツト	1
3		GBR-01175000	ROD END NUT, LEFT		ロツクネツト ナツト	2
4		NH-6060002-SD	NUT M6		ロツクネツト M6	2
5		GBR-01146000	CONNECTING ROD		ロツクネツト	1
6		NH-6040001-SC	NUT M4		ロツクネツト M4	1
7		WS-0410002-KR	SPRING WASHER, M4		ロツクネツト M4	1
8		GBR-01171000	ROD END 2		ロツクネツト	2
9		WP-0450000-SD	WASHER 4.5X8X0.5	A.10/81	ロツクネツト 4.5X8X0.5	1
10		WP-0612066-CP	WASHER 6.1X11X2		ロツクネツト 6.1X11X2	1
11		B1116-804-000	CLOTH PLATE WASHER		ロツクネツト	2
12		GBR-01177000-A	THRUST SUPPORT PLATE		ロツクネツト	1
13		RO-6465701-00	RUBBER RING		ロツクネツト	1
14		GBR-011440A0	PULLEY ASM., SMALL		ロツクネツト	1
15		SS-0120010-TP	SCREW 3/16-28 L=9		ロツクネツト 3/16-28 L=9	4
16		WS-0410002-KR	SPRING WASHER, M4		ロツクネツト M4	2
17		GBR-011470A0	SPINNER OSCILLATING ARM LEVER ASM.		ロツクネツト	1
18		SS-0660512-TP	SCREW 1/4-40 L=5		ロツクネツト 1/4-40 L=5	6
19		NS-6090310-SP	NUT 9/64-40		ロツクネツト 9/64-40	3
20		B2557-230-00B	WASHER		ロツクネツト	2
21		GBR-01169000	SEAL FOR NEEDLE BEARING		ロツクネツト	1
22		SS-0660010-TP	SCREW 1/4-40 L=8		ロツクネツト 1/4-40 L=8	2
23		GBR-011020A0	SIDE COVER 1 ASM.		ロツクネツト	1
24		GBR-01161000	NUT		ロツクネツト	1
25		GBR-01160000	ROLLER		ロツクネツト	1
26		GBR-01159000	WORK CLAMP FOOT LIFTING HOOK		ロツクネツト	1
27		GBR-01158000	UPPER & LOWER ARM		ロツクネツト	1
28		SS-0152130-CP	SCREW 15/64-28 L=20.5		ロツクネツト 15/64-28	1
29		SS-0151630-CP	SCREW 15/64-28 L=15.5		ロツクネツト 15/64-28	1
30		GBR-01141000	OSCILLATING LEVER		ロツクネツト	1
31		GBR-01140000	SPACER		ロツクネツト	1
32		GBR-011390A0	SPINNER SUPPORT ARM PIN ASM.		ロツクネツト	1
33		CQ-3030000-00	OIL WICK		ロツクネツト	(0.1)
34		GBR-01164000	LINK SUPPORT SHAFT		ロツクネツト	1
35		GBR-011380A0	HOLDING CLAMP DRIVE ARM ASM.		ロツクネツト	1
36		SS-0152130-CP	SCREW 15/64-28 L=20.5		ロツクネツト 15/64-28	(1)
37		GBR-01357000	SPRING HOOK		ロツクネツト	1
38		GBR-01123000	TENSION SPRING		ロツクネツト	1
39		GBR-01172000	ROLLER STUD BRACKET		ロツクネツト	1
40		NS-6110310-SP	NUT 11/64-40		ロツクネツト 11/64-40	2
41		SS-7112420-CP	SCREW 11/64-40 L=24		ロツクネツト 11/64-40 L=24	1
42		GBR-01119000-A	STOPPER PLATE	A.07/79	ロツクネツト	1
43		GBR-011350A0	STOPPER ASM.		ロツクネツト	1
44		GBR-011300A0	CLAMP RELEASE ARM ASM, A		ロツクネツト	1
45		NS-6080210-SP	NUT 1/8-44		ロツクネツト 1/8-44	2
46		SS-6081310-SP	SCREW 1/8-44 L=18.0		ロツクネツト 1/8-44 L=18	2
47		GBR-01129000	TENSION SPRING		ロツクネツト	1
48		PS-0400151-KH	SPRING PIN		ロツクネツト	1
49		GBR-01149000	WORK CLAMP ATTACHMENT		ロツクネツト	1
49-1	#02	GBR-01149A00	WORK CLAMP ATTACHMENT	A.05/83	ロツクネツト	1
50		GBR-01143000	ROTATING ROD		ロツクネツト	1
50-1	#02	GBR-01143A00	ROTATING ROD	A.05/83	ロツクネツト	1
51		GBR-011480A0	LEAF SPRING BRACKET ASM.		ロツクネツト	1
52		SS-8620610-SP	SCREW 3/16-32 L=6		ロツクネツト 3/16-32 L=6	(2)
53		GBR-011330A0-A	CLAMP RELEASE ARM ASM, B		ロツクネツト	1
54		SS-0660720-SP	SCREW 1/4-40 L=7		ロツクネツト 1/4-40 L=7	2
55		GBR-01176000	COVER		ロツクネツト	1
56		SS-0080410-CP	SCREW 1/8-44 L=4.3		ロツクネツト 1/8-44 L=4.3	1
57		GBR-01162000	ARM SHAFT		ロツクネツト	1
58		GBR-011500A0-A	SPINNER OSCILLATING ARM ASM.		ロツクネツト	1
59	#01	GBR-01152AAC	BUTTON CARRIER ASM.		ロツクネツト A	1
60	#01	GBR-01152BA0	BUTTON CARRIER ASM.		ロツクネツト B	1
61	#01	GBR-01152CA0	BUTTON CARRIER ASM.		ロツクネツト C	1
62	#01	GBR-01152DA0	BUTTON CARRIER ASM.		ロツクネツト D	1
63	*	SS-2090530-CP	SCREW 9/64-40 L=4.8	D.10/82	ロツクネツト SS-2090510-SP	-
64	*	SS-090510-SP	SCREW 9/64-40 L=5	A.10/82	ロツクネツト 9/64-40 L=5	2
65		GBR-01101000	BASE CASTING		ロツクネツト	1
66		SS-0152130-CP	SCREW 15/64-28 L=20.5		ロツクネツト 15/64-28	5
67		PT-0402000-CH	TAPERED PIN		ロツクネツト 4X20	4
68		SH-6061502-SD	SCREW M6 L=15		ロツクネツト M6 L=15	4
68		GBR-01137000	CAM ROLLER SHAFT		ロツクネツト	1

Note (注記) #01 Selecting part
 #02 Special order part
 (Small button)

選択部品
 特注部品(小ボタン用)

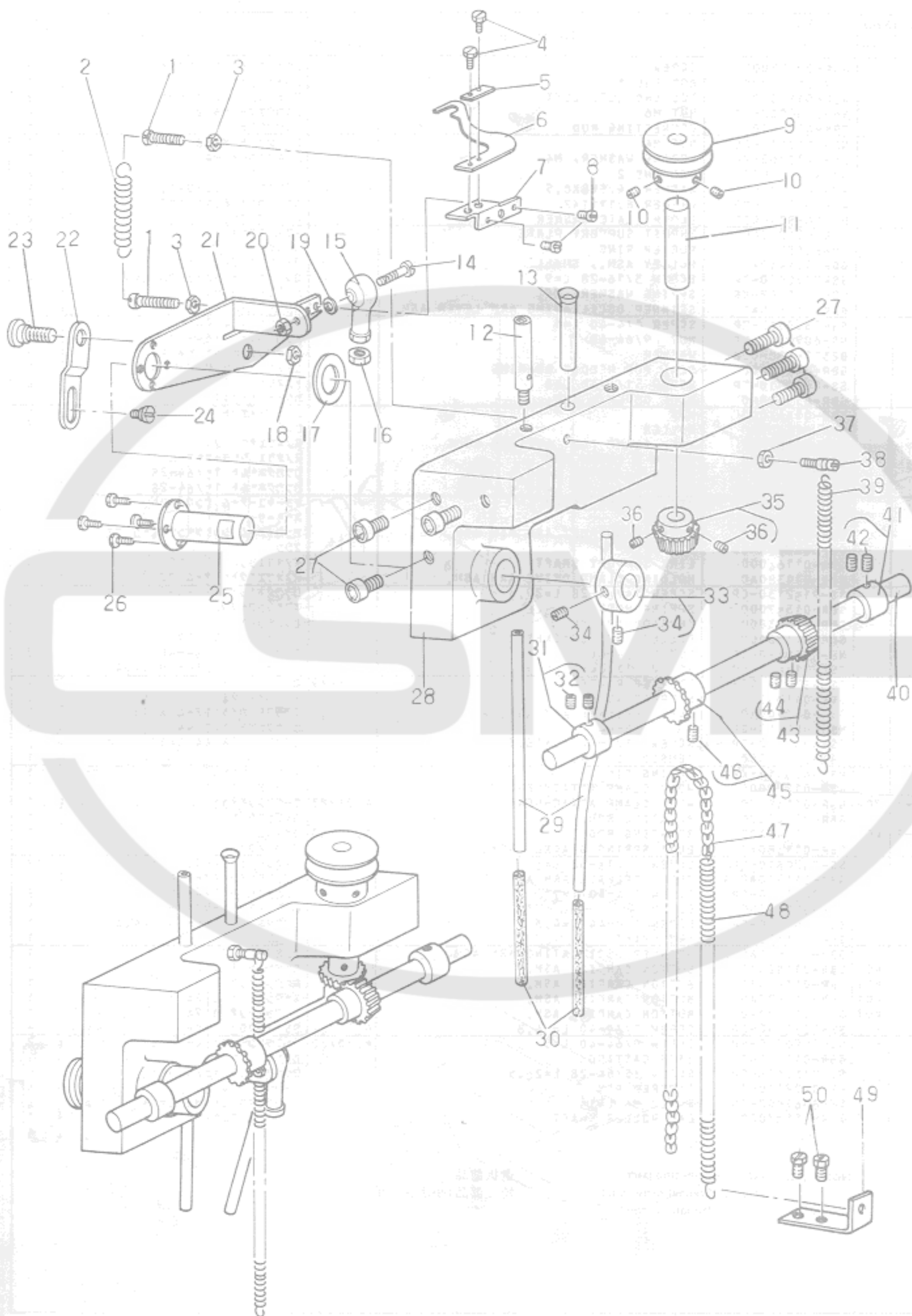

X1

Ref No.	Note	Part No. 品番	Description	E. C. 変更年月	品名	Amt. Req. 数量
1		SS-7112420-SP	SCREW 11/64-40 L=24		マルヒラシ* 11/64-40 L=24	2
2		GBR-01350000	TENSION SPRING		ヒツパ*リハ*ネ	1
3		NS-6110310-SP	NUT 11/64-40		ロツカクナツト 11/64-40	2
4		SS-9080410-SP	SCREW 1/8-44 L=4.3		ロツカクネ*ルト 1/8-44 L=4.3	2
5		GBR-01307000	LEAF SPRING PLATE		イタハ*ネ オウエ	1
6		GBR-01306000	LEAF SPRING		イタハ*ネ	1
7		GBR-01353000	LEAF SPRING MOUNTING		イタハ*ネ トリツケタ*イ	1
8		SS-9080410-SP	SCREW 1/8-44 L=4.3		ロツカクネ*ルト 1/8-44 L=4.3	2
9		GBR-01258000	PULLEY		フ*ーリ	1
10		SS-8110520-TP	SCREW 11/64-40 L= 4.5		トメネシ* 11/64-40 L=4.5	2
11		GBR-01257000	DRIVE PULLEY SHAFT FOLLOWER		シ*ユート*フ*ーリ シ*ク	1
12		GBR-01178000	REINFORCEMENT STUD A		ホキヨ*スタツト A	1
13		GBR-01182000-A	GUIDE PIPE		アンナイハ*イフ*	1
14		GBR-01173000	SCREW		ロツ*エント* トリツケネシ*	1
15		GBR-01171000	ROD END 2		ロツ*エント*	1
16		GBR-01175000	ROD END NUT, LEFT		ロツ*エント* ナツト ヒタ*リ	1
17		GBR-01304000	SPACER		ス*ー*ウ	1
18		NS-6120310-SP	NUT 3/16-28		ロツカクナツト 3/16-28	1
19		WS-0410002-KR	SPRING WASHER, M4		ハ*ネサ*カ*ネ M4	1
20		NS-6090310-SP	NUT 9/64-40		ロツカクナツト 9/64-40	2
21		GBR-01302000	DRIVING ARM		ク*ー*ア*ム	1
22		GBR-01308000	CONNECTING LINK 1		レンケツリンク	1
23		SD-0600321-SP	HINGE SCREW D= 6 H= 3.2		タ*ンネシ* D=6 H=3.2	1
24		SD-0600402-TP	HINGE SCREW D= 6 H= 4		タ*ンネシ* D=6 H=4	1
25		GBR-01303000	SET SCREW		ク*ー*ア*ム トリツケヒ*ン	1
26		SS-9080410-SP	SCREW 1/8-44 L=4.3		ロツカクネ*ルト 1/8-44 L=4.3	4
27		SM-6062002-SP	SCREW M6 L=20		ロツカクア*ナ*ネ*ルト M6 L=20	6
28		GBR-011040A0	REINFORCEMENT YASM.		ホキヨ*イタ クミ	1
29		GBR-01165000	GUIDE PIPE 1	0.05/79	アンナイハ*イフ*	-
30		CQ-3030000-00	OIL WICK		ユシ*ン	1.0
31		GBR-012590A0	THRUST COLLAR ASM.		スラストウケ クミ	1
32		SS-8110520-TP	SCREW 11/64-40 L= 4.5		トメネシ* 11/64-40 L=4.5	(2)
33		GBR-013540A0	THRUST COLLAR ASM.		カラ* クミ	1
34		SS-8110520-TP	SCREW 11/64-40 L= 4.5		トメネシ* 11/64-40 L=4.5	(2)
35		GBR-012560A0	MITRE GEAR ASM.		マイタ*ギア クミ	1
36		SS-8110520-TP	SCREW 11/64-40 L= 4.5		トメネシ* 11/64-40 L=4.5	(2)
37		NS-6090310-SP	NUT 9/64-40		ロツカクナツト 9/64-40	1
38		GBR-01352000	SHUTTER OPERATING ARM SPRING		シャツ*ター ヒキハ*ネ	1
39		GBR-01105000	TENSION SPRING		ヒツパ*リハ*ネ	1
40		GBR-01255000	DRIVE PULLEY SHAFT		ク*ー*フ*ーリ シ*ク	1
41		GBR-012590A0	THRUST COLLAR ASM.		スラストウケ クミ	1
42		SS-8110520-TP	SCREW 11/64-40 L= 4.5		トメネシ* 11/64-40 L=4.5	(2)
43		GBR-012560A0	MITRE GEAR ASM.		マイタ*ギア クミ	1
44		SS-8110520-TP	SCREW 11/64-40 L= 4.5		トメネシ* 11/64-40 L=4.5	(2)
45		GBR-012610A0	LADDER WHEEL ASM.		ラダ*ー*ホイ*ル クミ	1
46		SS-8110520-TP	SCREW 11/64-40 L= 4.5		トメネシ* 11/64-40 L=4.5	(1)
47		GBR-01260000	LADDER CHAIN		ラダ*ー*チ*ェ*ン	1
48		GBR-01253000	TENSION SPRING		ヒツパ*リハ*ネ	1
49		GBR-01252000	SPRING HOOK		スフ*リンク* フック	1
50		SS-9091010-SP	SCREW 9/64-40 L=10		ロツカクネ*ルト 9/64-40 L=10	2

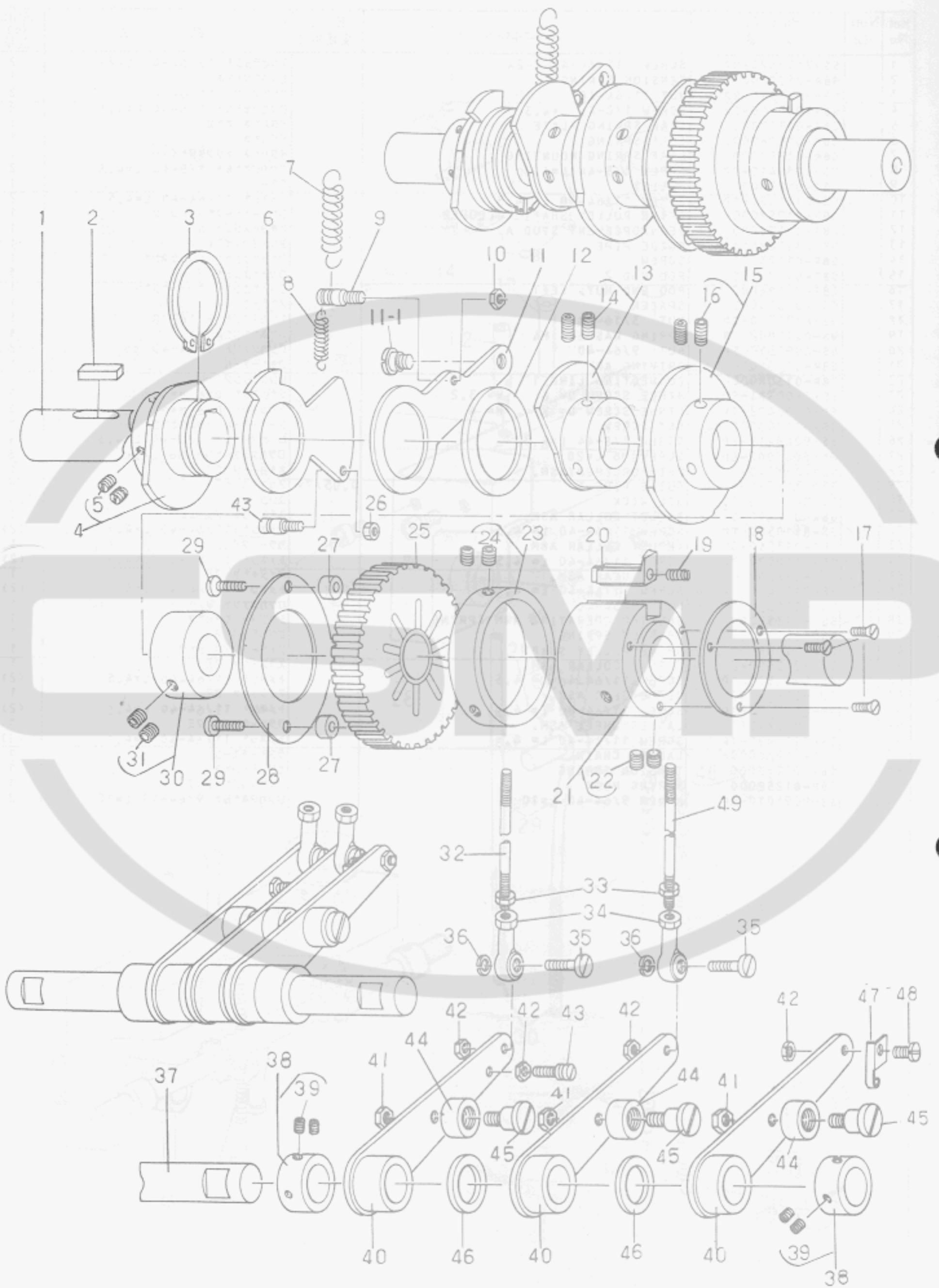

Ref. No.	Note 注記	Part No. 品番	Description	E. C. 変更年月	品名	Amt. Req. 数量
1		GBR-01106000-A	CAM SHAFT	A.07/79	カムシャフト	1
2		GBR-01128000-A	KEY		キ-	1
3		RC-2500001-KP	RETAINING RING 25		シムリング 25	1
4		GBR-011270A0	DOUBLE CAM		ダブルカム	1
5		SS-8110520-TP	SCREW 11/64-40 L= 4.5		ボルト 11/64-40 L=4.5	(2)
6		GBR-01121000	FABRIC PRESSER KNITTING CAM		布押圧カム	1
7		GBR-01126000-A	TENSION SPRING	A.01/79	テンションスプリング	1
8		GBR-01184000	TENSION SPRING		テンションスプリング	1
9		GBR-01125000	SPRING HOOK B		スプリングフック B	1
10		NS-6110310-SP	NUT 11/64-40		ナット 11/64-40	1
11		GBR-01124000	START TIMING CAM		スタートタイミングカム	1
11-1		SD-0790602-SP	HINGE SCREW D= 7.94 H= 6	A.10/80	ヒンジボルト D=7.94 H=6	1
12		GBR-01120000	COLLAR		カラー	1
13		GBR-011180A0	TRANSFER ARM CAM ASM.		アームセンカカムアサ	1
14		SS-8660512-TP	SCREW 1/4-40 L=5		ボルト 1/4-40 L=5	(2)
15		GBR-011170A0	CHUTE DRIVING CAM ASM.		シュート駆動カムアサ	1
16		SS-8660512-TP	SCREW 1/4-40 L=5		ボルト 1/4-40 L=5	(2)
17		SS-2090530-SP	SCREW 9/64-40 L= 4.8		ボルト 9/64-40 L=4.8	3
18		GBR-01107000	SPRING CLIP		スプリングクリップ	1
19		GBR-01110000	COMPRESSION SPRING		圧縮スプリング	1
20		GBR-01109000	CLUTCH KEY		クラッチキー	1
21		GBR-011080A0	SLEEVE ASM.		スリーブアサ	1
22		SS-8660512-TP	SCREW 1/4-40 L=5		ボルト 1/4-40 L=5	(1)
23		GBR-011110A0	KEY GUIDE RING ASM.		キーガイドリングアサ	1
24		SS-8660512-TP	SCREW 1/4-40 L=5		ボルト 1/4-40 L=5	(2)
25		GBR-011120A0	DRIVING GEAR ASM		駆動ギアアサ	1
26		NS-6090310-SP	NUT 9/64-40		ナット 9/64-40	1
27		GBR-01114000	COLLAR		カラー	2
28		GBR-01115000	CLAMP OPERATING CAM		クランプ操作カム	1
29		SS-6111210-SP	SCREW 11/64-40 L=12		ボルト 11/64-40 L=12	2
30		GBR-011160A0	COLLAR ASM.		カラーアサ	1
31		SS-8660512-TP	SCREW 1/4-40 L=5		ボルト 1/4-40 L=5	(2)
32		GBR-01206000	CONNECTING ROD 1		リンクソケット	1
33		NM-6040001-SC	NUT M4		ナット M4	2
34		GBR-01170000	ROD END 1		ソケットエンド	2
35		GBR-01173000	SCREW		ボルト トリツクボルト	2
36		WS-0410002-KR	SPRING WASHER, M4		ハネワシ M4	2
37		GBR-01205000	ARM SUPPORT SHAFT		アーム支持シャフト	1
38		CS-120101A-SH	THRUST COLLAR ASM.		スラストカラーアサ	2
39		SS-8660512-TP	SCREW 1/4-40 L=5		ボルト 1/4-40 L=5	(2)
40		GBR-012020A0	ARM BOSS ASM.		アームボスアサ	3
41		NS-6150310-SP	NUT 15/64-28		ナット 15/64-28	3
42		NS-6090310-SP	NUT 9/64-40		ナット 9/64-40	4
43		GBR-01357000	SPRING HOOK		スプリングフック	1
44		GBR-01211000	ROLLER FOLLOWER		ローラ フォロア	3
45		GBR-01210000	ROLLER MOUNTING BOLT		ローラ トリツクボルト	3
46		GBR-01204000	SPACER	D.04/79	スペーサ	-
47		GBR-01251000	CHAIN HOOK		チェーン フック	1
48		SD-0500251-SP	HINGE SCREW D= 5 H= 2.5		ヒンジボルト D=5 H=2.5	1
49		GBR-01207000	CONNECTING ROD 2		リンクソケット	1

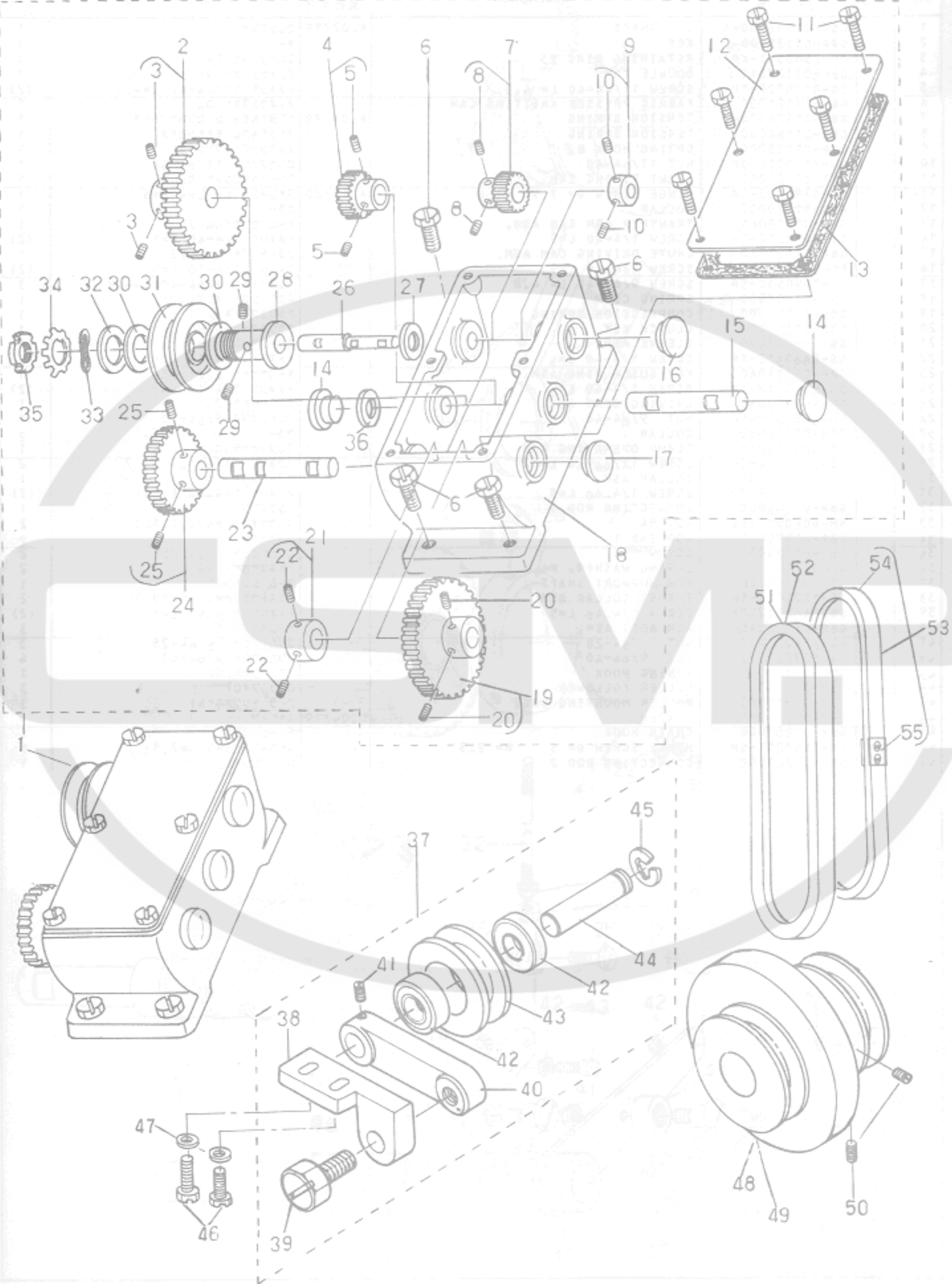

Ref. No.	Note	Part No. 品番	Description	E. C. 変更年月	品名	Amt. Req. 数量
1		GBR-015100A0	REDUCER ASM.		ケ*ソクキ クミ	1
2		GBR-015230A0	NEUTRAL GEAR, LARGE ASM.		チユ-カンキ*ヤ (ク*イ) クミ	(1)
3		SS-8660512-TP	SCREW 1/4-40 L=5		トメネシ* 1/4-40 L=5	(2)
4		GBR-015240A0	NEUTRAL GEAR, SMALL ASM.		チユ-カンキ*ヤ (シヨ-) クミ	(1)
5		SS-8660512-TP	SCREW 1/4-40 L=5		トメネシ* 1/4-40 L=5	(2)
6		SS-9151740-CP	SCREW 15/64-28 L=17		ロツカクホ*ルト 15/64-28 L=17	(4)
7		GBR-015200A0	PINION GEAR ASM.		ヒ*ニオン クミ	(1)
8		SS-8110520-TP	SCREW 11/64-40 L= 4.5		トメネシ* 11/64-40 L=4.5	(2)
9		GBR-012590A0	THRUST COLLAR ASM.		スラストウケ クミ	(1)
10		SS-8110520-TP	SCREW 11/64-40 L= 4.5		トメネシ* 11/64-40 L=4.5	(2)
11		SS-9091010-SP	SCREW 9/64-40 L=10		ロツカクホ*ルト 9/64-40 L=10	(6)
12		GBR-01512000	MAIN BODY COVER		ホ*タイ フタ	(1)
13		GBR-01511000	PACKING		ハ*ツ*ン	(1)
14		GBR-01532000	BLIND PATCH B		メクラセン B	(2)
15		GBR-01522000	NEUTRAL AXIS		チユ-カンシ*ク	(1)
16		GBR-01533000	BLIND PATCH C		メクラセン C	(1)
17		GBR-01531000	BLIND PATCH A		メクラセン A	(1)
18		GBR-015100B0	MAIN BODY ASM.		ケ*ソクキ ホ*タイ クミ	(1)
19		GBR-015290A0	OUTPUT GEAR ASM.		シユツリヨクキ*ヤ クミ	(1)
20		SS-8660512-TP	SCREW 1/4-40 L=5		トメネシ* 1/4-40 L=5	(2)
21		GBR-015280A0	THRUST COLLAR ASM.		スラストカラ- クミ	(1)
22		SS-8660512-TP	SCREW 1/4-40 L=5		トメネシ* 1/4-40 L=5	(2)
23		GBR-01525000	OUTPUT AXIS		シユツリヨクシ*ク	(1)
24		GBR-015260A0	FLAT GEAR ASM.		ヒラハク*ルマ クミ	(1)
25		SS-8660512-TP	SCREW 1/4-40 L=5		トメネシ* 1/4-40 L=5	(2)
26		GBR-01513000	INPUT AXIS		ニユ-リヨクシ*ク	(1)
27		GBR-01535000	OIL SEAL		オイルシール	(1)
28		GBR-01514000	PULLEY MOUNTING BOSS		フ*ーリ トリツケホ*ス	(1)
29		SS-8660512-TP	SCREW 1/4-40 L=5		トメネシ* 1/4-40 L=5	(2)
30		GBR-01516000	FRICTION PLATE		マツタイタ	(2)
31		GBR-015180A0	V-PULLEY ASM.		V フ*ーリ クミ	(1)
32		GBR-01515000	WASHER		ワ*カ*ネ	(1)
33		GBR-01538000	LIMITER WAVE WASHER		リミッター ウエ-フ*ワシヤ-	(1)
34		GBR-01536000	WASHER		シ*クワケヨ- ワ*カ*ネ	(1)
35		GBR-01537000	NUT		シ*クワケヨ- ナツト	(1)
36		GBR-01534000	OIL SEAL		オイルシール	(1)
37		GBR-015010B0	TENSION PULLEY ASM.		テンションキ*コ- クミ	1
38		GBR-01505000	TENSION PULLEY MOUNTING		テンションフ*ーリ トリツケダ*イ	(1)
39		SS-9282540-CP	SCREW 7/16-16 L=25		ロツカクホ*ルト 7/16-16 L=25	(2)
40		GBR-01503000	ARM		ア-ム	(1)
41		SS-8110520-TP	SCREW 11/64-40 L= 4.5		トメネシ* 11/64-40 L=4.5	(1)
42		GBR-01506000	RADIAL BEARING		ラシ*アル ハ*アリソク*	(2)
43		GBR-01501000	TENSION PULLEY		テンションフ*ーリ	(1)
44		GBR-01502000	PULLEY SHAFT		フ*ーリシ*ク	(1)
45		RE-0800000-K0	SNAP RING 8		Eカ*タメワ 8	(1)
46		SS-9151740-CP	SCREW 15/64-28 L=17		ロツカクホ*ルト 15/64-28 L=17	2
47		WP-0621016-SD	WASHER 6.2X13X1		ヒラワ*カ*ネ 6.2X13X1	2
48	001	GBR-0150400A	MOTOR PULLEY 50 HZ		モ-タフ*ーリ 50HZ	1
49	002	GBR-0150400B	MOTOR PULLEY 60 HZ		モ-タフ*ーリ 60HZ	1
50		SS-8661030-SP	SCREW 1/4-40 L=10		トメネシ* 1/4-40 L=10	2
51	001	MTJ-VH002500	V-BELT, 25 INCH		Vハ*ルト 25インチ	1
52	002	MTJ-VH002400	V-BELT, 24 INCH		Vハ*ルト 24インチ	1
53		MTJ-VH00000A	V BELT ASM.		V0-フ* レ-シソク* クミ	1
54		MTJ-VH000000	V BELT		Vハ*ルト (ハイム)	(0.7)
55		B7129-372-000	LACING		レ-シソク*	(1)

Note (注記) 001 For 50 Hz
 002 For 60 Hz

50HZ用
 60HZ用

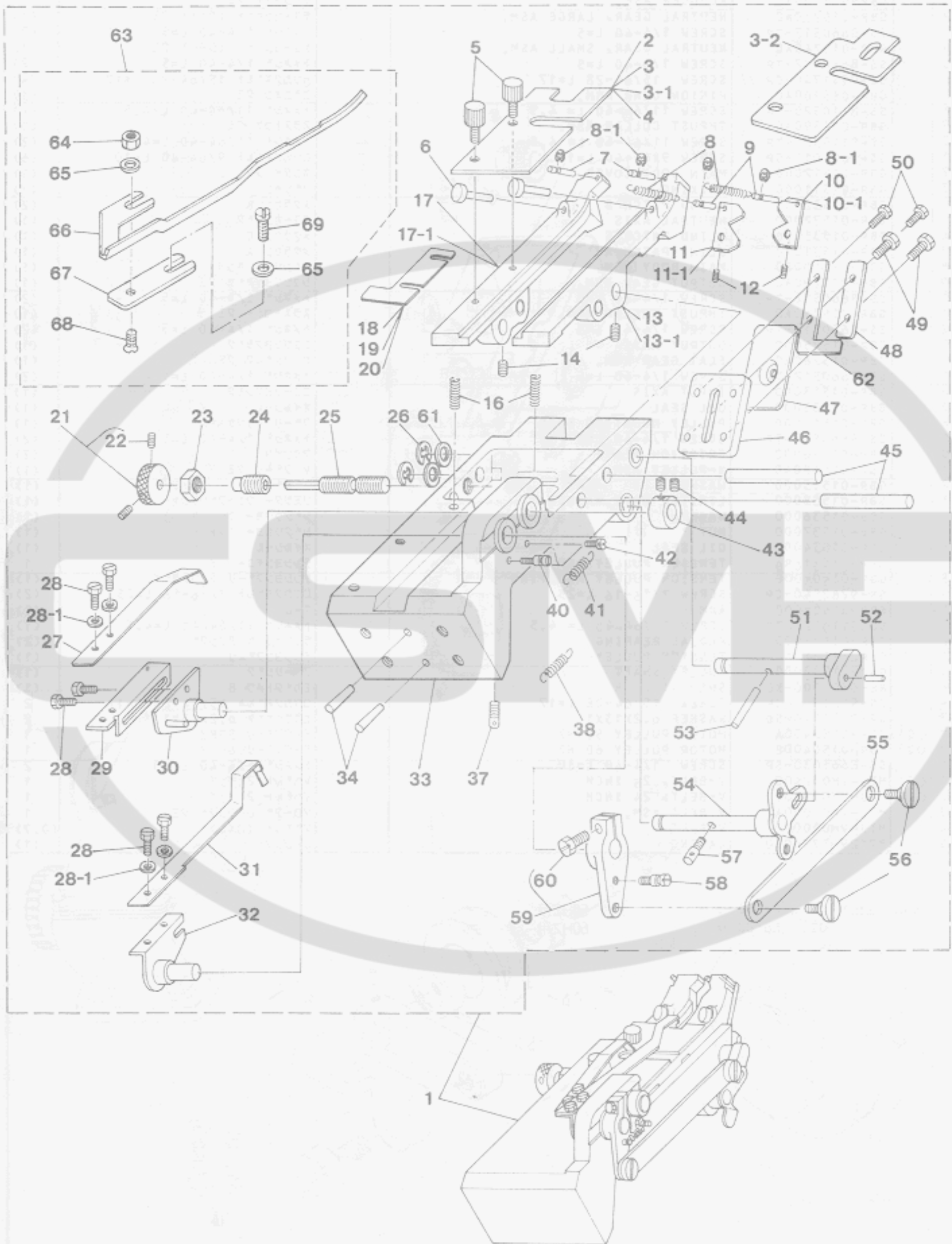

*

Ref. No.	Note 注記	Part No. 品番	Description	E.C. 変更年月	品名	Amt. Req. 数量
1		GBR-013010A0	CHUTE FOR SPECIAL CARRIER ASM.		ファンリネクリ シュートフ ^ク ク ^ニ	1
2	#01	GBR-01319000	GUIDE PLATE, MEDIUM		アンナイタ チ ^ニ	(1)
3	#01	GBR-01318000	GUIDE PLATE, SMALL		アンナイタ ショ ^ニ	(1)
3-1	#01	GBR-0131800B	GUIDE PLATE, SMALL	A.11/85	アンナイタ ショ ^ウ	(1)
3-2	#01	GBR-0131800C	GUIDE PLATE, SMALL	A.11/85	アンナイハン ショ ^ウ	(1)
4	#01	GBR-01320000	GUIDE PALTE, LARGE		アンナイタ タ ^ニ	(1)
5		GBR-01359000	SCREW		シュートメネジ ^ク	(2)
6		GBR-01316000	GUIDE SHAFT		カ ^ニ イ ^ニ シ ^ク	(2)
7		GBR-01314000	SPRING HOOK B		スフ ^ニ リ ^ク フ ^ク B	(2)
8		GBR-01315000	BLOCK TENSION SPRING		フ ^ニ ロ ^ク ヒ ^ツ ハ ^ニ リ ^ハ ネ	(2)
8-1	*	RE-0150000-KP	SNAP RING 1.5	A.01/80	Eカ ^ニ タ ^ニ メ ^ク	(4)
9		GBR-01313000	SPRING HOOK A		スフ ^ニ リ ^ク フ ^ク A	(2)
10		GBR-01312000	SHUTTER GUIDE BLOCK, LEFT		シヤツターイタ カ ^ニ イ ^ニ フ ^ニ ロ ^ク ヒ ^ツ ハ ^ニ リ	(1)
10-1	#02	GBR-01312A00	SHUTTER GUIDE BLOCK, LEFT	A.05/83	シヤツターイタカ ^ニ イ ^ニ フ ^ニ ロ ^ク ヒ ^ツ ハ ^ニ リ	(1)
11		GBR-01311000	SHUTTER GUIDE BLOCK, RIGHT		シヤツターイタ カ ^ニ イ ^ニ フ ^ニ ロ ^ク ミ ^ニ キ	(1)
11-1	#02	GBR-01311A0A	SHUTTER GUIDE BLOCK, RIGHT	A.05/83	シヤツターイタカ ^ニ イ ^ニ フ ^ニ ロ ^ク ミ ^ニ キ	(1)
12		SS-8090540-SP	SCREW 9/64-40 L=5		トメネジ ^ク 9/64-40 L=5	(2)
13		GBR-01310000	SLIDING WAY, LEFT		ス ^ニ ハ ^ニ リ ^タ イ ヒ ^ツ ハ ^ニ リ	(1)
13-1	#02	GBR-01310A00	SLIDING WAY, LEFT	A.05/83	ス ^ニ ハ ^ニ リ ^タ イ ヒ ^ツ ハ ^ニ リ	(1)
14		SS-8110520-TP	SCREW 11/64-40 L=4.5		トメネジ ^ク 11/64-40 L=4.5	(2)
16		GBR-01355000-A	COMPRESSION SPRING		ス ^ニ ハ ^ニ リ ^タ イ ト ^ニ シ ^ハ ネ	(1)
17		GBR-01309000	SLIDING WAY, RIGHT		ス ^ニ ハ ^ニ リ ^タ イ ミ ^ニ キ	(1)
17-1	#02	GBR-01309A00	SLIDING WAY, RIGHT	A.05/83	ス ^ニ ハ ^ニ リ ^タ イ ミ ^ニ キ	(1)
18	#01	GBR-01322000	SPACER T=0.5		ス ^ニ ハ ^ニ ニ ^ニ T=0.5	(1)
19	#01	GBR-01321000	SPACER T=1.0		ス ^ニ ハ ^ニ ニ ^ニ T=1.0	(1)
20	#01	GBR-01323000	SPACER T=0.2		ス ^ニ ハ ^ニ ニ ^ニ T=0.2	(1)
21		GBR-013380A0	ADJUSTMENT KNOB ASM.		チヨ ^ニ セツツマ ^ニ ク ^ニ	(1)
22		SS-8090540-SP	SCREW 9/64-40 L=5		トメネジ ^ク 9/64-40 L=5	(2)
23		NS-6740510-SP	NUT 3/8-28		ロツカクナツト 3/8-28	(1)
24		GBR-01337000	ADJUSTMENT BOLT		チヨ ^ニ セ ^ニ キ ^ニ ネ ^ニ ルト	(1)
25		GBR-01336000	SCREW SHAFT		スク ^ニ リ ^ニ ニ ^ニ シ ^ク	(1)
26		RE-0400000-K0	SNAP RING 4		Eカ ^ニ タ ^ニ メ ^ク 4	(2)
27		GBR-01327000	SPECIAL ARM B		フ ^ニ ン ^ニ リ ^ニ ア ^ニ ル B	(1)
28		SS-9080410-SP	SCREW 1/8-44 L=4.3		ロツカクネ ^ニ ルト 1/8-44 L=4.3	(6)
28-1		WP-0330500-OE	WASHER 3.3X6X0.5	A.02/84	ヒ ^ツ ワ ^ニ カ ^ニ ネ 3.3X6X0.5	(4)
29		GBR-01328000	SPECIAL ARM MOUNTING		フ ^ニ ン ^ニ リ ^ニ ア ^ニ ル B ト ^ニ リ ^ツ ク ^ニ タ ^ニ イ	(1)
30		GBR-013290A0-A	ARM B INSTALLATION BASE ASM.		フ ^ニ ン ^ニ リ ^ニ ア ^ニ ル ト ^ニ リ ^ツ ク ^ニ タ ^ニ イ B ク ^ニ	(1)
31	*	GBR-01324000	SPECIAL CARRIER ARM A	D.11/85	フ ^ニ ン ^ニ リ ^ニ ア ^ニ ル A	-
	*	GBR-01324000-A	SPECIAL CARRIER ARM A	A.11/85	フ ^ニ ン ^ニ リ ^ニ ア ^ニ ル A	(1)
32		GBR-013250A0-A	SPECIAL CARRIER ARM MOUNTING ASM.		フ ^ニ ン ^ニ リ ^ニ ア ^ニ ル ト ^ニ リ ^ツ ク ^ニ タ ^ニ イ A ク ^ニ	(1)
33		GBR-013010B0-A	CHUTE ASM.		シュートネ ^ニ ン ^ニ タイ ク ^ニ	(1)
34		PT-0402000-CH	TAPERED PIN		テ ^ニ ハ ^ニ ニ ^ニ ピ ^ニ ン 4X20	(2)
37		GBR-01351000	SPRING HOOK		スフ ^ニ リ ^ク フ ^ク	(1)
38		GBR-01352000	SHUTTER OPERATING ARM SPRING		シヤツター ヒ ^ニ キ ^ニ ハ ^ニ ネ	(1)
40		GBR-01357000	SPRING HOOK		スフ ^ニ リ ^ク フ ^ク	(1)
41		GBR-01333000	TENSION SPRING		ヒ ^ツ ハ ^ニ リ ^ハ ネ	(1)
42		SS-7112420-SP	SCREW 11/64-40 L=24		マルヒ ^ツ ワ ^ニ ネジ ^ク 11/64-40 L=24	(1)
43		GBR-013540A0	THRUST COLLAR ASM.		カラ ^ニ ク ^ニ	(1)
44		SS-8110520-TP	SCREW 11/64-40 L=4.5		トメネジ ^ク 11/64-40 L=4.5	(2)
45		GBR-01335000	GUIDE SHAFT		アンナイシ ^ク	(2)
46		GBR-01349000	SHUTTER BRACKET		シヤツターイ ^ニ タ ^ニ ク ^ニ	(1)
47		GBR-01347000	SHUTTER	D.02/84	GBR-0134700A	-
		GBR-0134700A	SHUTTER	A.02/84	タ ^ニ イ ^ニ ネ ^ニ タ ^ニ ン シヤツタイ ^ニ	(1)
48		GBR-01348000	GUIDE PLATE		カ ^ニ イ ^ニ ニ ^ニ イ ^ニ	(1)
49		SS-6111210-SP	SCREW 11/64-40 L=12		ヒ ^ツ ワ ^ニ ネジ ^ク 11/64-40 L=12	(2)
50		SS-9080410-SP	SCREW 1/8-44 L=4.3		ロツカクネ ^ニ ルト 1/8-44 L=4.3	(2)
51		GBR-01342000	SHUTTER DRIVE SHAFT		シヤツター ク ^ニ ト ^ニ ニ ^ニ シ ^ク	(1)
52		GBR-01343000	DRIVE PIN		ク ^ニ ト ^ニ ニ ^ニ ピ ^ニ ン	(1)
53		GBR-01346000	SHUTTER OPERATING PIN		シヤツターイ ^ニ タ ^ニ カ ^ニ イ ^ニ ニ ^ニ ピ ^ニ ン	(1)
54		GBR-013400A0	BUTTERFLY LINK ASM.		チヨ ^ニ セ ^ニ カ ^ニ ニ ^ニ リ ^ク ク ^ニ	(1)
55		GBR-01334000	CONNECTING LINK 2		レン ^ニ ク ^ニ ツ ^ニ リ ^ク	(1)
56		SD-0530221-SP	HINGE SCREW D= 5.3 H= 2.2		タ ^ニ ン ^ニ ネジ ^ク D=5.3 H=2.2	(2)
57		GBR-01351000	SPRING HOOK		スフ ^ニ リ ^ク フ ^ク	(1)
58		GBR-01357000	SPRING HOOK		スフ ^ニ リ ^ク フ ^ク	(1)
59		GBR-013320A0	DRIVING ARM ASM.		フ ^ニ ン ^ニ リ ^ニ サ ^ニ ト ^ニ ニ ^ニ ア ^ニ ル ク ^ニ	(1)
60		SS-6091210-TP	SCREW 9/64-40 L=12		ヒ ^ツ ワ ^ニ ネジ ^ク 9/64-40 L=12	(1)
61		B3227-771-000	WASHER		イト ^ニ マ ^ニ キ ^ニ フ ^ニ ツ ^ニ シ ^ニ ア ^ニ	(2)
62	*	GBR-01361000	GUIDE PLATE	A.02/79	カ ^ニ イ ^ニ ニ ^ニ イ ^ニ	(1)
63	*	GBR-013620A0	CHUTE SPRING ASM.	A.11/85	シュ ^ニ ツ ^ニ ト ^ニ ハ ^ニ ネ ク ^ニ	(1)
64	*	NS-6110420-SP	NUT 11/64-40	A.11/85	ロツカクナツト 11/64-40	(1)
65	*	WP-0501016-SD	WASHER 5X10.5X1	A.11/85	ヒ ^ツ ワ ^ニ カ ^ニ ネ 5X10.5X1	(2)
66	*	GBR-01362000	CHUTE SPRING	A.11/85	シュ ^ニ ツ ^ニ ト ^ニ ハ ^ニ ネ	(1)
67	*	GBR-01363000	CHUTE SPRING SET PLATE	A.11/85	シュ ^ニ ツ ^ニ ト ^ニ ハ ^ニ ネ ト ^ニ リ ^ツ ク ^ニ	(1)
68	*	SS-1110840-SP	SCREW 11/64-40 L=8	A.11/85	ワ ^ニ ラ ^ニ ネジ ^ク 11/64-40 L=8	(1)
69	*	SS-7111120-SP	SCREW 11/64-40 L=10.5	A.11/85	マルヒ ^ツ ワ ^ニ ネジ ^ク 11/64-40 L=10.5	(1)

Note (注記) #01 Selecting part
 #02 Special order part (Small button)

選択部品
 特注部品(小ボタン用)

1 2

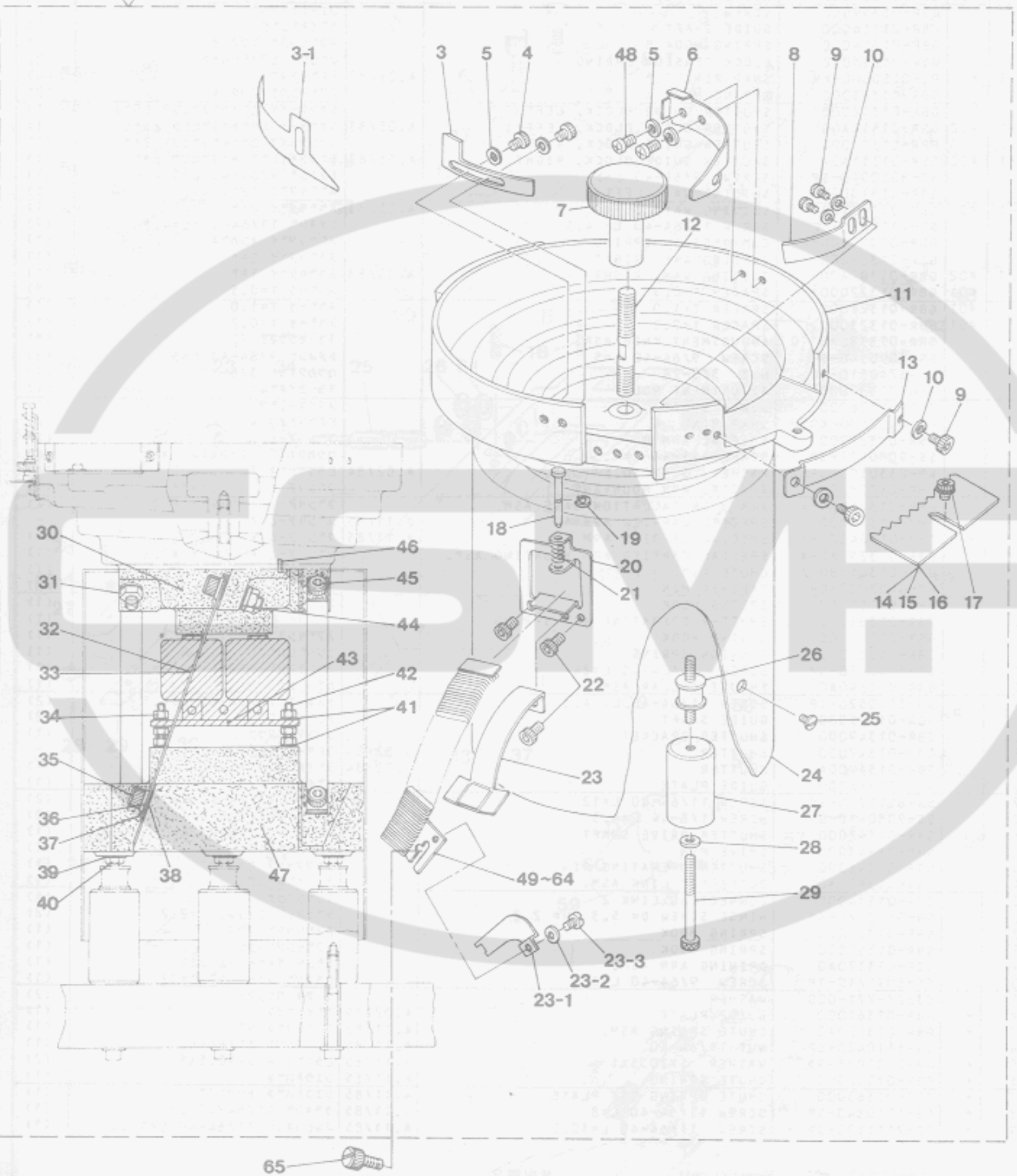

Ref. No.	Note	Part No.	Description	E.C. 変更年月	品名	Amt. Req. 数量
1	#01	GBR-014000AA	BUTTON FEEDER ASM. 50 HZ		フイター 50HZ クミ	1
2	#02	GBR-014000AB	BUTTON FEEDER ASM. 60 HZ		フイター 60HZ クミ	1
3		GBR-01425000	STOPPER		ホップ止 トメイ	(1)
3-1	*	GBR-01441000	BUTTON STANDING PREVENT PLATE	A.12/85	ホップ止 ホールシヤ	(1)
4	*	SM-6040602-SD	SCREW M4X0.7 L=6	M.03/79	ロツクアナボルト M4X0.7 L=6	(2)
5		WP-0430800-SF	WASHER M4		ヒラサカネ コカワル M4	(4)
6		GBR-01426000	GUIDE PLATE		アソビ板	(1)
7		GBR-01431000	BOWL FIXING KNOB		ボール コチノブ	(1)
8		GBR-01427000	WORK LIMIT PLATE		ワーク セイゲン板	(1)
9		SM-6030602-SD	SCREW M3X0.5 L=6		ロツクアナボルト M3X0.5 L=6	(4)
10		WP-0320500-SF	WASHER 3.2X7X0.5		ヒラサカネ コカワル M3	(2)
11		GBR-01402000	FEEDER BOWL		フイター ボール	(1)
12		GBR-01432000	BOWL FIXING SCREW		ボール コチネジ	(1)
13		GBR-01428000	GUIDE PLATE		ガイド板	(1)
14	#03	GBR-01423000	SELECTOR PLATE, MEDIUM		センハツ板 チュー	(1)
15	#03	GBR-01422000	SELECTOR PLATE, SMALL		センハツ板 ショー	(1)
16	#03	GBR-01424000	SELECTOR PLATE, LARGE		センハツ板 タイ	(1)
17		SL-6051012-SD	SCREW M5		ロツクアナボルト M5	(1)
18		GBR-01413000	CHUTE CLAMP PIN		シュート クランプピン	(1)
19		RE-0250000-K0	SNAP RING 2.5		Eカクメツ 2.5	(1)
20		GBR-01414000	CHUTE MOUNTING PLATE		シュート トリツクタイ	(1)
21		GBR-01421000	COMPRESSION SPRING		アツシクバネ	(1)
22		SM-6050802-SD	SCREW M5X0.8 L=8		ロツクアナボルト M5X0.8 L=8	(3)
23		GBR-014300A0	CHUTE SUPPORTER ASM.		シュートサツ クミ	(1)
23-1		GBR-01440000	BUTTON STOPPER PLATE	A.11/83	ホップ止板	(1)
23-2		WS-0441040-KP	SPRING WASHER 4.4X7.4X1	A.11/83	ハネサカネ 4.4X7.4X1	(1)
23-3		SS-7110350-SP	SCREW 11/64-40 L=3	A.11/83	スクリュー 11/64-40 L=3.5	(1)
24		GBR-01433000	COVER		カバー	(1)
25	*	SS-5150510-SP	SCREW 15/64-28 L=5	M.03/79	スクリュー 15/64-28 L=5	(3)
26		GBR-01429000	RUBBER VIBRATION INSULATOR		ホーシヨク	(4)
27		GBR-01401000	FEEDER SUPPORTER		フイター サツ	(4)
28		WP-0641600-SF	WASHER M6		ヒラサカネ M6	(4)
29		SM-6065002-SD	SCREW M6 L=50		ロツクアナボルト M6 L=50	(4)
30		GBR-01403000	BOWL MOUNTING		ボール トリツクタイ	(1)
31		NM-6080001-SA	NUT M8		ロツクナツ M8 1個	(4)
32	#01	GBR-0140500A	LEAF SPRING 50 HZ		イロバネ 50HZ	(4)
33	#02	GBR-0140500B	LEAF SPRING 60 HZ		イロバネ 60HZ	(4)
34		NM-6050001-SA	NUT M5		ロツクナツ M5X0.8 1個	(12)
35		SM-6082502-SD	SCREW M8 L=25		ロツクアナボルト M8 L=25	(4)
36		GBR-01406000	SPACER		スパー	(8)
37		PS-0200101-KH	SPRING PIN 2.0X10		スプリングピン 2X10	(8)
38		GBR-01407000	SPACER		スパー	(8)
39		WS-0610002-KS	SPRING WASHER M6		ハネサカネ	(4)
40		NM-6060001-SA	NUT M6		ロツクナツ M6 1個	(4)
41		WS-0510002-KS	SPRING WASHER M5		ハネサカネ M5	(8)
42		SM-6053502-SD	SCREW M5X0.8 L=35		ロツクアナボルト M5X0.8 L=35	(4)
43		GBR-014100A0	CORE ASM.		コア クミ	(1)
44		WS-0820002-KS	SPRING WASHER 8.2X15.4X2		ハネサカネ 8.2X15.4X2	(4)
45		SM-6083002-SD	SCREW M8 L=30		ロツクアナボルト M8 L=30	(4)
46		PS-0600121-KH	SPRING PIN 6X12		スプリングピン 6X12	(1)
47		GBR-01404000	BASE		ボディ	(1)
48		SS-5110810-SP	SCREW 11/64-40 L=8		スクリュー 11/64-40 L=8	(2)
49	#03	GBR-01415AA0	CHUTE ASM., 2.7X15		シュート 2.7X15 クミ	(1)
50	#03	GBR-01415BA0	CHUTE ASM., 3.5X17		シュート 3.5X17 クミ	(1)
51	#04	GBR-01415CA0	CHUTE ASM., 2.5X13		シュート 2.5X13 クミ	(1)
52	#04	GBR-01415DA0	CHUTE ASM., 2.3X15	A.01/80	シュート 2.3X15 クミ	(1)
53	#04	GBR-01415EA0	CHUTE ASM., 4X25	A.01/80	シュート 4X25 クミ	(1)
54	#04	GBR-01415FA0	CHUTE ASM., 3.6X20	A.01/80	シュート 3.6X20 クミ	(1)
55	#04	GBR-01415GA0	CHUTE ASM., 5X25	A.01/80	シュート 5X25 クミ	(1)
56	#04	GBR-01415HA0	CHUTE ASM., 2.5X17	A.01/80	シュート 2.5X17 クミ	(1)
57	#04	GBR-01415JA0	CHUTE ASM., 4.5X18	A.01/80	シュート 4.5X18 クミ	(1)
58	#04	GBR-01415KA0	CHUTE ASM., 4X17	A.01/80	シュート 4.0X17 クミ	(1)
59	#04	GBR-01415LA0	CHUTE ASM., 3X23	A.01/80	シュート 3.0X23 クミ	(1)
60	#04	GBR-01415MA0	CHUTE ASM., 4X15	A.01/80	シュート 4.0X15 クミ	(1)
61	#04	GBR-01415NA0	CHUTE ASM., 4.5X15	A.01/80	シュート 4.5X15 クミ	(1)
62	#04	GBR-01415PA0	CHUTE ASM., 3.2X13	A.01/80	シュート 3.2X13 クミ	(1)
63	#04	GBR-01415RA0	CHUTE ASM., 5.7X22	A.08/81	シュート 5.7X22 クミ	(1)
64	#04	GBR-01415SA0	CHUTE ASM., 2X13	A.08/81	シュート クミ	(1)
65		GBR-01359000	SCREW		シュートボルト	1

Note (注記) #01 For 50 Hz 50HZ用
 #02 For 60 Hz 60HZ用
 #03 Selecting part 選択部品
 #04 Special order part 特別注文部品

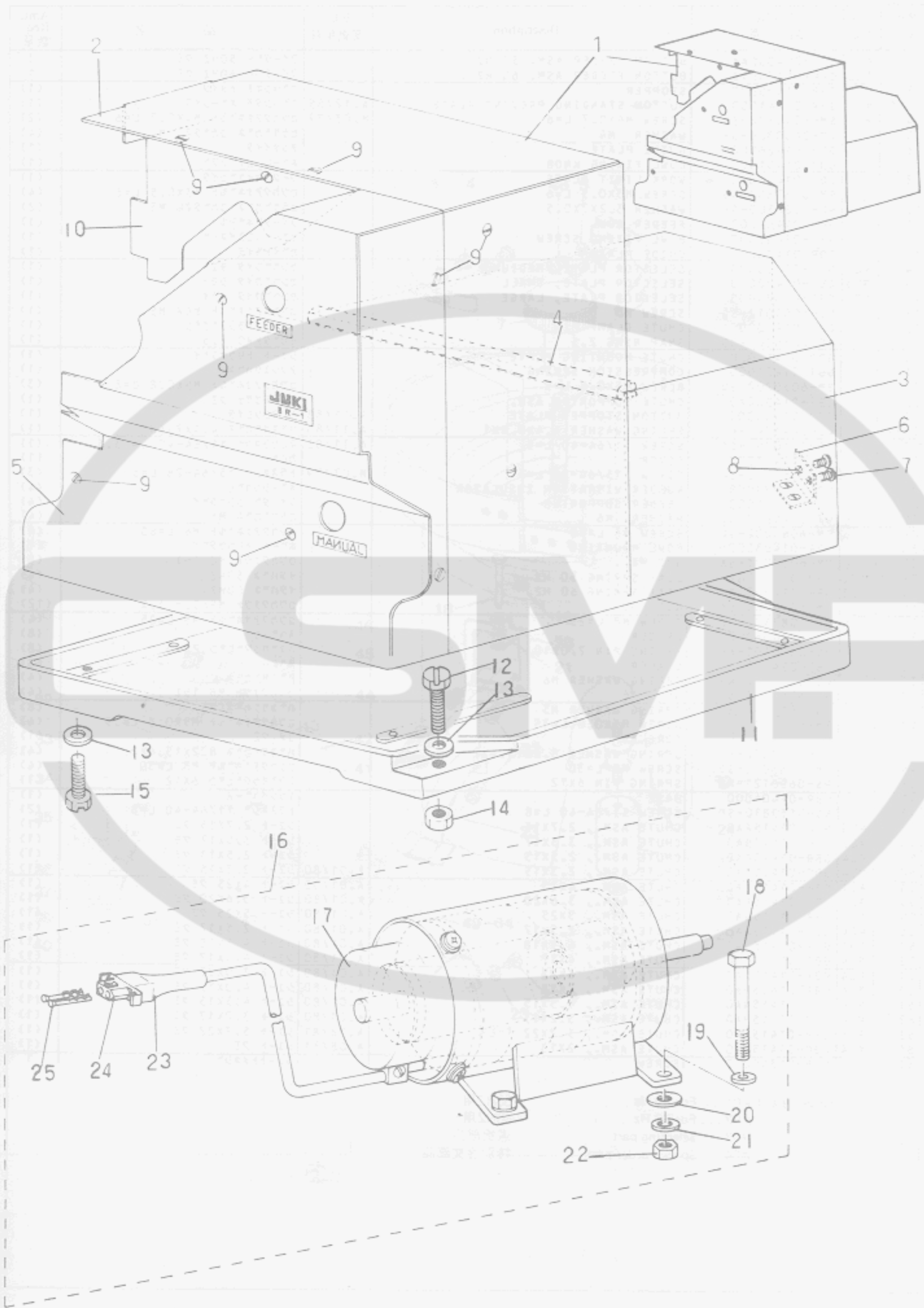

Ref. No.	Note 注記	Part No. 品番	Description	E. C. 変更年月	品名	Amt. Req. 数量
1		GBR-019010A0	LOADER COVER ASM.		ロータ-カバー- クミ	1
2		GBR-01901000	LOADER INSIDE COVER		ロータ- ナカカバー-	(1)
3		GBR-01903000	LOADER REAR COVER		ロータ- 後ろカバー-	(1)
4		GBR-01910000	RUBBER CUSHION		クッションゴム	(1)
5		GBR-019020A0	LOADER FRONT COVER ASM.		ロータ- フロントカバー- クミ	(1)
6		GBR-01906000	COVER T		カバー- Tカバー	(1)
7		SS-3090610-SP	SCREW 9/64-40 L=6		マルネジ 9/64-40 L=6	(4)
8		NS-6090310-SP	NUT 9/64-40		ロツカクナツト 9/64-40	(2)
9		SS-3090610-SP	SCREW 9/64-40 L=6		マルネジ 9/64-40 L=6	(9)
10		GBR-01905000	LOADER INSIDE COVER		ロータ- うちカバー-	(1)
11		B1103-372-R00	BASE		ベース	1
12		SS-9156830-CP	SCREW 15/64-28 L=68	D.09/80	SS-9156830-SP	-
		SS-9156830-SP	SCREW 15/64-28 L=68	A.09/80	ロツカクネルト 15/64-28 L=68	4
13		WP-0612056-SD	WASHER 6.1X18.5X2		ヒラサカネ 6.1X18.5X2	5
14		NS-6150310-SP	NUT 15/64-28		ロツカクナツト 15/64-28	4
15		SS-9154540-SP	SCREW 15/64-28 L=45		ロツカクネルト 15/64-28 L=45	1
16		GBR-017110A0	STARTING MAGNET ASM.		キト- マクネツト クミ	1
17		GBR-01711000	STARTING MAGNET		キト- マクネツト	(1)
18		SS-9165530-SP	SCREW 1/4-24 L=55		ロツカクネルト 1/4-24 L=55	(4)
19		WP-0651001-SB	WASHER M6		ヒラサカネ ミカキネ M6	(4)
20		WP-0751576-SD	WASHER 7.5X19X1.5		ヒラサカネ 7.5X19X1.5	(4)
21		WS-0651510-KP	SPRING WASHER 6.5X12.5X1.5		ハネサカネ 6.5X12.5X1.5	(4)
22		NS-6160520-SP	NUT 1/4-24		ロツカクナツト 1/4-24	(4)
23		MAT-81126T00	2-POLE PLUG COVER		2P フラクカバー-	(1)
24		MAI-15040000	2-POLE PLUG		2キヨク ナイロク フラク	(1)
25		D6043-555-800	PIN TERMINAL, MALE		ピン タ-ミナル オス	(2)

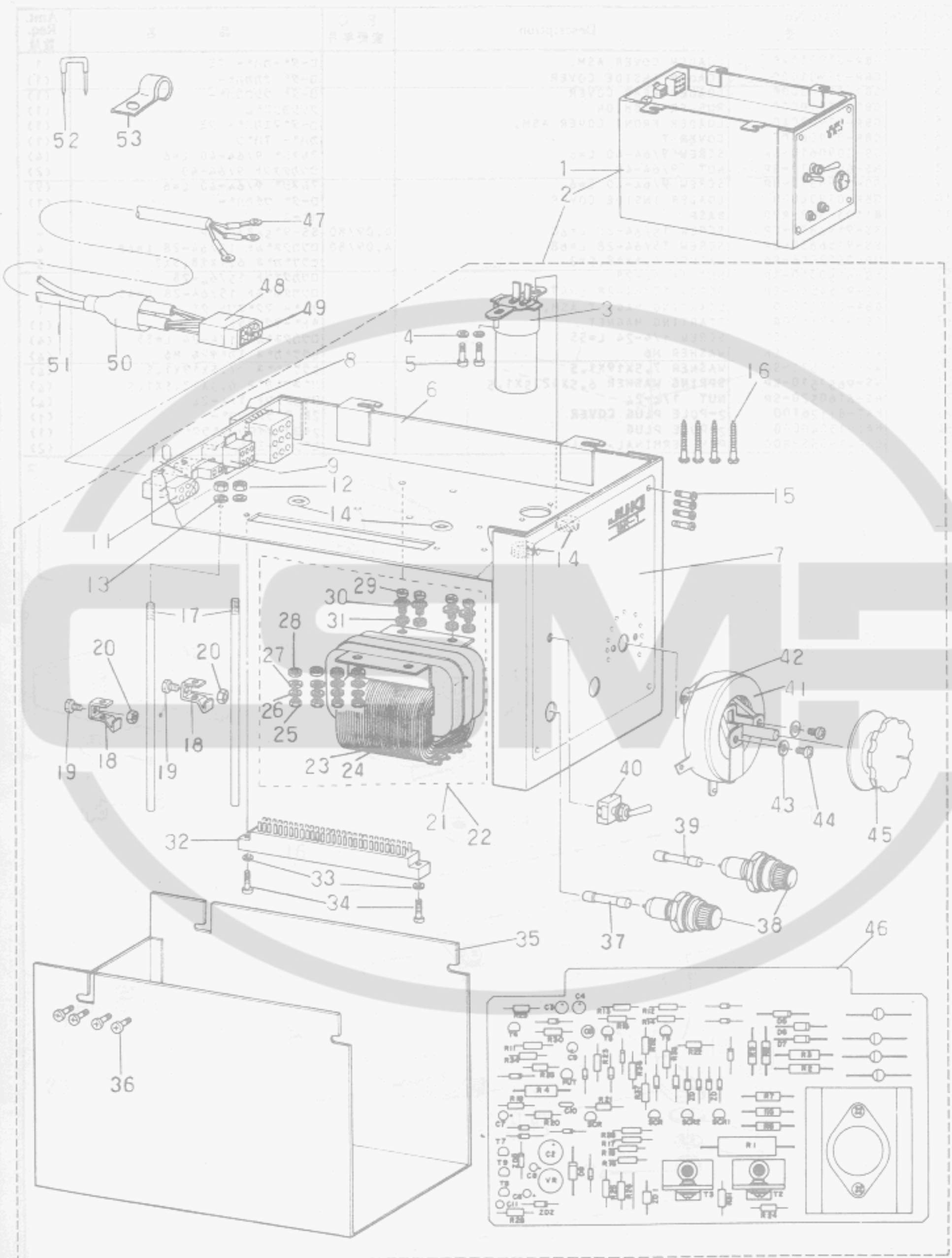

Ref. No.	Note	Part No. 品番	Description	E. C. 変更年月	品名	Amt. Req. 数量
1	#01	GBR-017020AA	CONTROL BOX ASM, A		コントロールボックス アスミ A	1
2	#02	GBR-017020AB	CONTROL BOX ASM, B		コントロールボックス アスミ B	1
3		HC-0001500-00	CAPACITOR 2200/50		コンデンサ 2200MF 50V テンカイ	(1)
4		WS-0310702-KB	SPPING WASHER 3.1X5.3X0.7	D.08/79	WS-0310702-KS	-
		WS-0310702-KS	SPPING WASHER	A.08/79	ハネワカネ 3.1X5.9X0.7	(2)
5	*	SM-4030501-SB	SCREW #3 L=5	D.02/83	SL-4030681-SF	-
	*	SL-4030681-SF	SCREW #3 L=6	A.02/83	ナハコネシ ねじ M3 L=6	(2)
6		GBR-01702000	CONTROL BOX		コントロールボックス	(1)
7		GBR-01703000	CONTROL INDICATING BOARD		コントロール ショウハイン	(1)
8		D6028-555-80A	9-POLE PLUG, WHITE		9P ナイロンプラグ ホワイト	(1)
9		D6029-555-80B	NYLON RECEPTACLE 6P		6P ナイロンレセプタクル	(1)
10		MA1-15041000	NYLON RECEPTACLE 2P		2P レセプタクル	(1)
11		GBR-01715000	6POLE NYLON PLUG		6P ナイロンプラグ	(1)
12		NM-6040000-SB	NUT M4X0.7		ロツクナット M4X0.7 152	(2)
13		WS-0411002-KB	SPPING WASHER 4		ハネワカネ	(2)
14		MAT-01263000	RUBBER BUSHING		ゴムワッシャー	(4)
15		SM-4920501-SB	SCREW #2.6X0.45 L=5		ナハネシ M2.6X0.45 L=5	(4)
16		SK-7452500-00	WOOD SCREW D=4.5 L=25		丸目ネジ D=4.5 L=25	(4)
17		MAT-01254000	SUPPORTING STUD		キハシネシ ねじ	(2)
18		MAT-01255000	SET PLATE		キハシメカク	(2)
19		SM-9040603-00	SCREW #4 L=6		ロツクネット M4X0.7 L=6	(2)
20		NM-6040000-SB	NUT M4X0.7		ロツクナット M4X0.7 152	(2)
21	#01	GBR-017100AA	POWER TRANSFORMER ASM, A		テングコントランス A アスミ	(1)
22	#02	GBR-017100AB	POWER TRANSFORMER ASM, B		テングコントランス B アスミ	(1)
23	#01	GBR-0171000A	POWER TRANSFORMER A		テングコントランス A	(1)
24	#02	GBR-0171000B	POWER TRANSFORMER B		テングコントランス B	(1)
25	*	NM-6040000-SB	NUT M4X0.7	D.02/83	NM-6040002-SC	-
	*	NM-6040002-SC	NUT M4	A.02/83	ロツクナット M4X0.7 352	(4)
26		WS-0411002-KB	SPPING WASHER 4		ハネワカネ	(4)
27		WP-0450501-SB	WASHER	D.01/82	WP-0430801-SC	-
		WP-0430801-SC	WASHER M4	A.01/82	ヒラワカネ ミカキネ M4	(4)
28		MAO-16007000	INSULATED WASHER B		セツイン ワッシャー B	(4)
29	*	SM-4041201-SB	SCREW M4 L=12	D.02/83	SL-4041281-SF	-
	*	SL-4041281-SF	SCREW M4X0.7 L=12	A.02/83	ナハネシ M4X0.7 L=12 ねじ	(4)
30		WP-0450501-SB	WASHER	D.01/82	WP-0430801-SC	-
		WP-0430801-SC	WASHER M4	A.01/82	ヒラワカネ ミカキネ M4	(4)
31		MAO-16006000	INSULATED WASHER A		セツイン ワッシャー A	(4)
32		MAT-01253000	P.C BOARD CONNECTOR		キハシコネクタ	(1)
33		WS-0310702-KB	SPPING WASHER 3.1X5.3X0.7	D.08/79	WS-0310702-KS	-
		WS-0310702-KS	SPPING WASHER	A.08/79	ハネワカネ 3.1X5.9X0.7	(2)
34	*	SM-4030801-SB	SCREW #3 L=8	D.02/83	SL-4030881-SF	-
	*	SL-4030881-SF	SCREW #3 L=8	A.02/83	ナハコネシ ねじ M3 L=8	(2)
35		MAT-01242000	CONTROL BOX COVER		ボックスカバー	(1)
36	*	SM-4040601-SB	SCREW #4 L=6	D.02/83	SM-5040601-SC	-
	*	SM-5040601-SC	SCREW #4X0.7 L=6	A.02/83	ハインコネシ M4X0.7 L=6	(4)
37		D6110-555-800	FUSE 5A		ヒューズ 5A	(1)
38		MAT-80142700	FUSE HOLDER		ヒューズホルダ	(2)
39		GBR-01709000	FUSE 1A		ヒューズ 1A	(1)
40		MAO-14506000	SWITCH		スイッチ	(1)
41		GBR-01705000	RESISTOR 200 OHM		タイコキ 200オーム テンヨウマキセン	(1)
42		HG-0005200-00	DIODE 3BZ61		ダイオード (3BZ61)	(1)
43		WP-0330500-1B	WASHER 3.3X6X0.5		ヒラワカネ コカネ M3	(2)
44	*	SM-4030801-SB	SCREW #3 L=8	D.02/83	SL-4030881-SF	-
	*	SL-4030881-SF	SCREW #3 L=8	A.02/83	ナハコネシ ねじ M3 L=8	(2)
45		GBR-01706000	VOLUME KNOB		ボリュームノブ	(1)
46		GBR-017010A0	PRINTED CIRCUIT BOARD ASM.		プリント基板 アスミ	(1)
47		HP-1A43PEC-12	CRIMP STYLE TERMINAL		アツチクダシ	3
48		GBR-01803000	6POLE NYLON RECEPTACLE		6P ナイロンレセプタクル	1
49		D6042-555-800	PIN-SHAPE TERMINAL, FEMALE		ピンターミナル メス	6
50		MAT-81131700	COVER		6P プラグカバー	1
51		HW-5F18S16-A8	3-CORE CABLEYRE CORD		3芯 ケブタイコート 1M	1.8
52		MAO-11532000	STAPLE	M.07/80	コート スタプラー	40
53		MAZ-02508000	CORD HOLDER		コート ヒキメ	1

Note (注記) #01 For 100, 115, 200, 240V 100, 115, 200, 240V用
 #02 For 100, 220, 380, 415V 100, 220, 380, 415V用

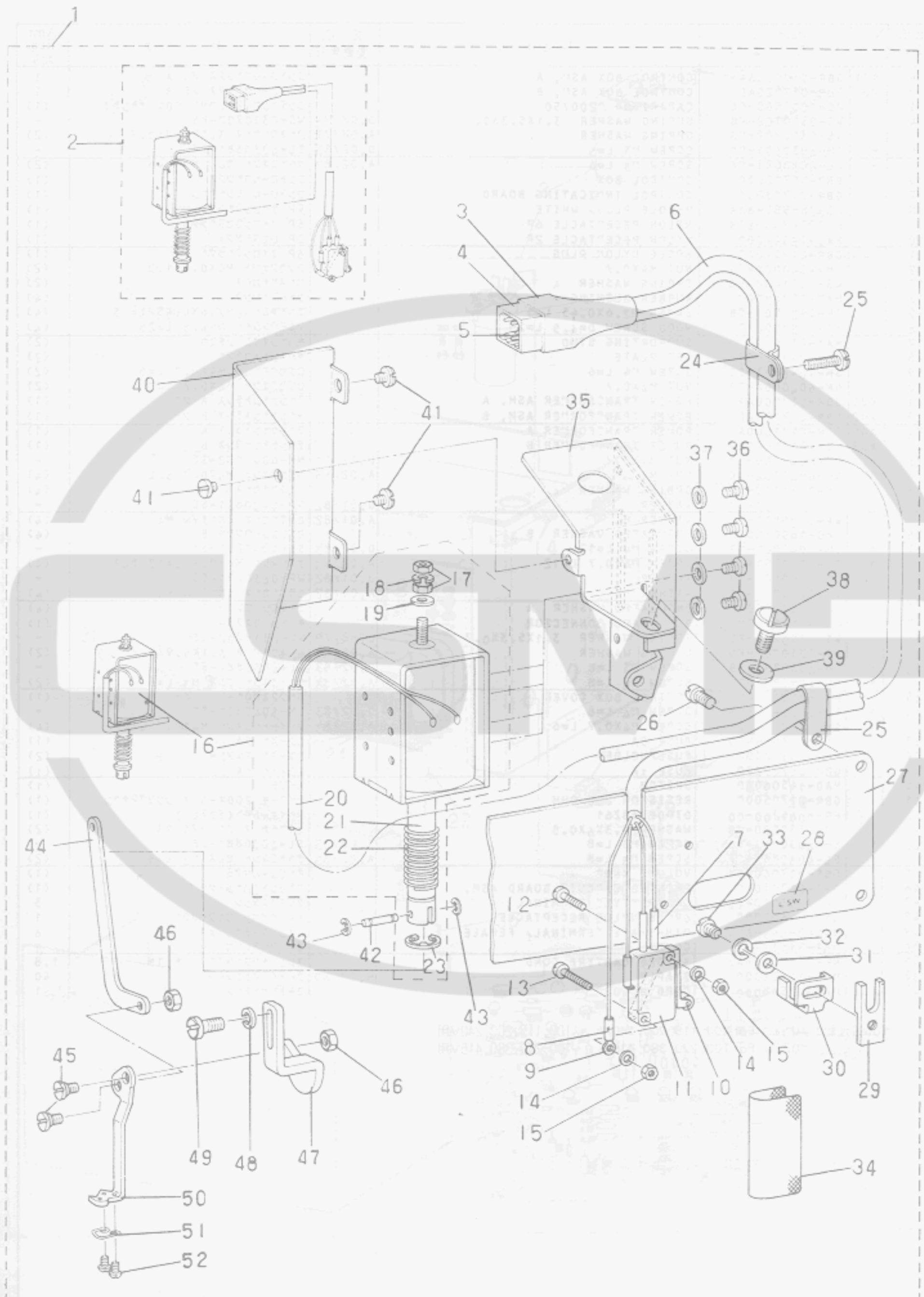

Ref. No.	Note	Part No. 品番	Description	E. C. 変更年月	品名	Amt. Req. 数量
1		MAZ-025010C0	WIPER COMPONENTS UNIT		ワイパ-カンケイ ユニツト	1
2		MAZ-025010R0	L.SW CORD ASM.		L-SWコート*クミ	(1)
3		MAT-81131T00	COVER		6P フラク*カハ-	(1)
4		D6029-555-800	6-POLE RECEPTACLE, WHITE		6P コンセント シロ (オス)	(1)
5		D6043-555-800	PIN TERMINAL, MALE		ピン タ-ミナル オス	(1)
6		HW-5F18S12-48	4-CORE CABTYRE CORD		キヤフ*タイヤコート* 0.18X19X4	(1.1)
7		MAO-11512000	VINYL TUBE A		ビニ-ル チューブ* A	(3)
8		MAT-80158T00	GROUND WIRE MARK TUBE		ア-スマ-ク チューブ*	(1)
9		HP-1A32PLC-12	SOLDERLESS TERMINAL		アツチャクタンシ (マルカ*タ)	(1)
10		MAO-11514000	ACTUATOR		アクチエ-タ	(1)
11		MAO-51503000	MICRO SWITCH		マイクロ スイツチ	(1)
12		SM-4031601-SB	SCREW M3X0.5 L=16		ナ*コネシ* M3X0.5 L=16	(1)
13		SM-4032001-SB	SCREW M3X0.5 L=20		ナ*コネシ* M3X0.5 L=20	(1)
14		WP-0330501-SB	WASHER M3		ヒラサ*カ*ネ ミカ*キマル M3	(2)
15		NM-6030001-MB	NUT		ロツカクナツト M3X0.5 152	(2)
16		MAZ-025010A0	WIPER MAGNET ASM.		ワイパ- マグ*ネツト クミ	(1)
17		NM-6043212-SB	NUT M4X0.7		ロツカクナツト M4X0.7 252	(2)
18		WS-0411022-SB	SPRING WASHER		ハ*ネツ*カ*ネ	(1)
19		MAT-80115T00	WASHER		フ*ランシ*ヤ- ストリハ- ヲ*	(1)
20		HW-5F18S12-28	2-CORE CABTYRE CORD		キヤフ*タイヤコート* 0.18X19X2	(1.3)
21		D2118-555-800-A	PLUNGER		フ*ランシ*ヤ-	(1)
22		D2106-555-800	SPRING FOR MAGNET		ワイパ- マグ*ネツト	(1)
23		RE-0901110-K0	SNAP RING 9		エカ*タトメウ 9	(1)
24		MAZ-02508000	CORD HOLDER		コート*ヒキ*メ	(2)
25		SS-7121410-SP	SCREW 3/16-28 L=14		マルヒラネシ* 3/16-28 L=14	(1)
26		SS-7111120-SP	SCREW 11/64-40 L=10.5		マルヒラネシ* 11/64-40 L=10.5	(1)
27		MAO-12502000	ARHSIDE COVER (LEFT)		ソクメンイタ ヒタ*リ	(1)
28		MAO-71515000	L.SW NAME PLATE		メイパ*ン LSW	(1)
29		MAO-12504000	L.SW ADJUSTING PLATE		L-SW チョ-セツイタ	(1)
30		MAO-12503000	L.SW SYNCHRONIZING PLATE		L-SW ケンシユツイタ	(1)
31		WP-0480856-SP	WASHER 4.8X8.4X0.8		ヒラサ*カ*ネ 4.8X8.4X0.8	(1)
32		WS-0451040-KP	SPRING WASHER		ハ*ネツ*カ*ネ 4.5X8.5X1	(1)
33		SS-7110740-TP	SCREW 11/64-40 L=7		マルヒラネシ* 11/64-40 L=7	(1)
34		MAO-12518000	SWITCH INSULATING PAPER		スイツチ セツインシ	(1)
35		MAZ-02502000	WIPER MAGNET INSTALLING BASE		ワイパ- マグ*ネツト トリツクタイ	(1)
36		SM-4040601-SB	SCREW M4 L=6		ナ*コネシ* M4X0.7 L=6	(4)
37		WP-0480856-SD	WASHER 4.8X8.4X0.8		ヒラサ*カ*ネ 4.8X8.4X0.8	(4)
38		SS-7151210-SP	SCREW 15/64-28 L=12		マルヒラネシ* 15/64-28 L=12	(1)
39		WP-0621016-SD	WASHER 6.2X13X1		ヒラサ*カ*ネ 6.2X13X1	(1)
40		MAZ-02503000	WIPER MAGNET INSTALLING BASE COVER		ワイパ- マグ*ネツト トリツクタイカハ-	(1)
41		SS-7110340-SP	SCREW 11/64-40 L= 3.2		マルヒラネシ* 11/64-40 L= 3.2	(3)
42		D2107-555-800	WIPER LINK SHAFT, A		ワイパ- リンクシャフト A	(1)
43		RE-0250000-KP	SNAP RING 2.5		エカ*タトメウ 2.5	(2)
44		MAZ-02504000	WIPER LINK		ワイパ- リンク	(1)
45		SD-0550211-SP	HINGE SCREW		タンネシ* D=5.5 H=2.1	(2)
46		NS-6110310-SP	NUT 11/64-40		ロツカクナツト 11/64-40	(2)
47		MAZ-02505000	WIPER BASE		ワイパ- ト*タイ	(1)
48		WS-0521010-KP	SPRING WASHER 5.2X8.5X1.0		ハ*ネツ*カ*ネ 5.2X8.2X1	(1)
49		SS-6121220-SP	SCREW 3/16-28 L=12.0		ヒラネシ* 3/16-28 L=11.5	(1)
50		MAZ-02506000	WIPER		ワイパ-	(1)
51		MAZ-02507000	WIPER THREAD GUARD SPRING		ワイパ- イトウケハ*ネ	(1)
52		SS-5060310-SP	SCREW 3/32-56 L=2.8		トラスネシ* 3/32-56 L=2.8	(2)

12. TABLE OF EXCHANGING PARTS

交換部品一覧表



(1) TABLE OF SPRING CHUTES

バネシュート一覧表

Inner dia. of chute シュート内径	Chute シュート	Inner dia. of chute シュート内径	Chute シュート
			
2.7 x 15 mm	GBR-01415AA0	3 x 23 mm	GBR-01415LA0
3.5 x 17 mm	GBR-01415BA0	4 x 15 mm	GBR-01415MA0
2.5 x 13 mm	GBR-01415CA0	4.5 x 15 mm	GBR-01415NA0
2.3 x 15 mm	GBR-01415DA0	3.2 x 13 mm	GBR-01415PA0
4 x 25 mm	GBR-01415EA0	4 x 20 mm	GBR-01415QA0
3.6 x 20 mm	GBR-01415FA0	5.7 x 22 mm	GBR-01415RA0
5 x 25 mm	GBR-01415GA0	2 x 13 mm	GBR-01415SA0
2.7 x 17 mm	GBR-01415HA0	3.6 x 25 mm	GBR-01415UA0
4.5 x 18 mm	GBR-01415JA0	1.4 x 13 mm	GBR-01415VA0
4 x 17 mm	GBR-01415KA0	4.3 x 20 mm	GBR-01415YA0

(2) TABLE OF BUTTON CARRIERS

ボタンキャリア一覧表

Distance between holes ボタン穴ピッチ	Button carrier ボタンキャリア	Set pin セットピン	Amt. Req. 数量
			
3.2 mm	GBR-01152AA0	GBR-01155000	2
3.8 mm	GBR-01152BA0	GBR-01155000	2
2.0 mm	GBR-01152EA0	GBR-01156000	2
2.2 mm	GBR-01152FA0	GBR-01156000	2
2.4 mm	GBR-01152GA0	GBR-01156000	2
2.6 mm	GBR-01152HA0	GBR-01156000	2
2.8 mm	GBR-01152JA0	GBR-01156000	2
3.0 mm	GBR-01152KA0	GBR-01156000	2
2.4 mm	GBR-01152LA0	GBR-01155000	2
2.6 mm	GBR-01152MA0	GBR-01155000	2
2.8 mm	GBR-01152NA0	GBR-01155000	2
3.0 mm	GBR-01152PA0	GBR-01155000	2
2.6 x 2.6 mm	GBR-01152CA0	GBR-01156000	4
3.1 x 3.1 mm	GBR-01152DA0	GBR-01156000	4
2.0 x 2.0 mm	GBR-01152QA0	GBR-01156000	4
2.2 x 2.2 mm	GBR-01152RA0	GBR-01156000	4
2.4 x 2.4 mm	GBR-01152SA0	GBR-01156000	4
2.4 x 2.4 mm	GBR-01152TA0	GBR-01155000	4
2.6 x 2.6 mm	GBR-01152UA0	GBR-01155000	4
2.8 x 2.8 mm	GBR-01152VA0	GBR-01155000	4
3.0 x 3.0 mm	GBR-01152WA0	GBR-01155000	4
4.0 x 4.0 mm	GBR-01152XA0	GBR-01155000	4
3.2 x 3.2 mm	GBR-01152YA0	GBR-01155G00	4

NUMERICAL INDEX OF PARTS

索引

Part No. 品番	Page 頁	Ref. No.	Part No. 品番	Page 頁	Ref. No.	Part No. 品番	Page 頁	Ref. No.	Part No. 品番	Page 頁	Ref. No.
BT-0300250-A0	4	40	GBR-01120000	10	12	GBR-01253000	8	48	GBR-014000AA	16	1
BT-0440330-20	4	43	GBR-01121000	10	6	GBR-01255000	8	40	GBR-014000AB	16	2
B1103-372-R00	18	11	GBR-01123000	6	38	GBR-012560A0	8	35	GBR-01401000	16	27
B1116-804-000	6	11	GBR-01124000	10	11	GBR-012560A0	8	43	GBR-01402000	16	11
B2540-372-000	2	38	GBR-01125000	10	9	GBR-01257000	8	11	GBR-01403000	16	30
B2541-372-000	2	39	GBR-01126000-A	10	7	GBR-01258000	8	9	GBR-01404000	16	47
B2542-372-RA0	2	1	GBR-011270A0	10	4	GBR-012590A0	8	31	GBR-0140500A	16	32
B2542-372-R00	2	20	GBR-01128000-A	10	2	GBR-012590A0	8	41	GBR-0140500B	16	33
B2544-372-000	2	40	GBR-01129000	6	47	GBR-012590A0	12	9	GBR-01406000	16	36
B2545-372-000	2	41	GBR-011300A0	6	44	GBR-01260000	8	47	GBR-01407000	16	38
B2546-372-000	2	2	GBR-011330A0-A	6	53	GBR-012610A0	8	45	GBR-014100A0	16	43
B2547-372-000	2	18	GBR-011350A0	6	43	GBR-013010A0	14	1	GBR-01413000	16	18
B2548-372-RA0	2	13	GBR-01137000	6	68	GBR-013010B0-A	14	33	GBR-01414000	16	20
B2549-372-R00	2	3	GBR-011380A0	6	35	GBR-01302000	8	21	GBR-01415AA0	16	49
B2552-372-R00	2	34	GBR-011390A0	6	32	GBR-01303000	8	25	GBR-01415BA0	16	50
B2553-372-000	2	35	GBR-01140000	6	31	GBR-01304000	8	17	GBR-01415CA0	16	51
B2555-372-RAA	2	21-1	GBR-01141000	6	30	GBR-01306000	8	6	GBR-01415DA0	16	52
B2555-372-RA0	2	21	GBR-01143A00	6	50-1	GBR-01307000	8	5	GBR-01415EA0	16	53
B2555-372-ROA	2	22-1	GBR-01143000	6	50	GBR-01308000	8	22	GBR-01415FA0	16	54
B2555-372-R00	2	22	GBR-011440A0	6	14	GBR-01309A00	14	17-1	GBR-01415GA0	16	55
B2556-372-ROA	2	23-1	GBR-01146000	6	5	GBR-01309000	14	17	GBR-01415HA0	16	56
B2556-372-R00	2	23	GBR-011470A0	6	17	GBR-01310A00	14	13-1	GBR-01415JA0	16	57
B2557-280-00B	6	20	GBR-011480A0	6	51	GBR-01310000	14	13	GBR-01415KA0	16	58
B2557-372-RAA	2	26-1	GBR-01149A00	6	49-1	GBR-013110A0	14	11-1	GBR-01415LA0	16	59
B2557-372-RA0	2	26	GBR-01149000	6	49	GBR-01311000	14	11	GBR-01415MA0	16	60
B2557-372-ROA	2	27-1	GBR-011500A0-A	6	58	GBR-01312A00	14	10-1	GBR-01415NA0	16	61
B2557-372-R00	2	27	GBR-01152AA0	6	59	GBR-01312000	14	10	GBR-01415PA0	16	62
B2558-372-R00	2	28	GBR-01152BA0	6	60	GBR-01313000	14	9	GBR-01415RA0	16	63
B2559-372-000	2	25	GBR-01152CA0	6	61	GBR-01314000	14	7	GBR-01415SA0	16	64
B2559-372-000	2	30	GBR-01152DA0	6	62	GBR-01315000	14	8	GBR-01421000	16	21
B2560-372-000	2	31	GBR-01158000	6	27	GBR-01316000	14	6	GBR-01422000	16	15
B2561-372-000	2	33	GBR-01159000	6	26	GBR-0131800B	14	3-1	GBR-01423000	16	14
B3125-012-000	2	42	GBR-01160000	6	25	GBR-0131800C	14	3-2	GBR-01424000	16	16
B3227-771-000	14	61	GBR-01161000	6	24	GBR-01318000	14	3	GBR-01425000	16	3
B4416-373-000	2	43	GBR-01162000	6	57	GBR-01319000	14	2	GBR-01426000	16	6
B4420-373-000	2	46	GBR-01164000	6	34	GBR-01320000	14	4	GBR-01427000	16	8
B7129-372-000	12	55	GBR-01169000	6	21	GBR-01321000	14	19	GBR-01428000	16	13
			GBR-01170000	6	2	GBR-01322000	14	18	GBR-01429000	16	26
			GBR-01170000	10	34	GBR-01323000	14	20	GBR-014300A0	16	23
			GBR-01171000	6	8	GBR-01324000	14	31	GBR-01431000	16	7
CQ-3030000-00	6	33	GBR-01171000	8	15	GBR-01324000-A	14	31	GBR-01432000	16	12
CQ-3030000-00	8	30	GBR-01172000	6	39	GBR-013250A0-A	14	32	GBR-01433000	16	24
CS-120101A-SH	10	38	GBR-01173000	6	1	GBR-01327000	14	27	GBR-01440000	16	23-1
			GBR-01173000	8	14	GBR-01328000	14	29	GBR-01441000	16	3-1
			GBR-01173000	10	35	GBR-013290A0-A	14	30	GBR-015010B0	12	37
D2106-555-B00	22	22	GBR-01175000	6	3	GBR-013320A0	14	59	GBR-01501000	12	43
D2107-555-B00	22	42	GBR-01175000	8	16	GBR-01333000	14	41	GBR-01502000	12	44
D2118-555-B00-A	22	21	GBR-01176000	6	55	GBR-01334000	14	55	GBR-01503000	12	40
D2120-555-C00	4	44	GBR-01177000-A	6	12	GBR-01335000	14	45	GBR-0150400A	12	48
D6028-555-80A	20	8	GBR-01178000	8	12	GBR-01336000	14	25	GBR-0150400B	12	49
D6028-555-80B	4	46	GBR-01182000-A	8	13	GBR-01337000	14	24	GBR-01505000	12	38
D6029-555-80B	20	9	GBR-01183000	4	25	GBR-013380A0	14	21	GBR-01506000	12	42
D6029-555-800	22	4	GBR-01184000	10	8	GBR-013400A0	14	54	GBR-015100A0	12	1
D6042-555-800	20	49	GBR-012020A0	10	40	GBR-01342000	14	51	GBR-015100B0	12	18
D6043-555-800	4	47	GBR-01205000	10	37	GBR-01343000	14	52	GBR-01511000	12	13
D6043-555-800	18	25	GBR-01206000	10	32	GBR-01346000	14	53	GBR-01512000	12	12
D6043-555-800	22	5	GBR-01207000	10	49	GBR-0134700A	14	47	GBR-01513000	12	26
D6110-555-800	20	37	GBR-01210000	10	45	GBR-01347000	14	47	GBR-01514000	12	28
D9317-762-T00	2	44	GBR-01211000	10	44	GBR-01348000	14	48	GBR-01515000	12	32
			GBR-012200B0	4	10	GBR-01349000	14	46	GBR-01516000	12	30
			GBR-01221000	4	27	GBR-01350000	8	2	GBR-015180A0	12	31
			GBR-01222000	4	3	GBR-01351000	14	37	GBR-015200A0	12	7
GBR-01101000	6	64	GBR-012230A0-A	4	2	GBR-01351000	14	57	GBR-01522000	12	15
GBR-011020A0	6	23	GBR-01225000-A	4	20	GBR-01352000	8	38	GBR-015230A0	12	2
GBR-011030A0	4	1	GBR-01227000	4	18	GBR-01352000	14	38	GBR-015240A0	12	4
GBR-011040A0	8	28	GBR-01229000-A	4	22	GBR-01353000	8	7	GBR-01525000	12	23
GBR-01105000	8	39	GBR-01231000	4	5	GBR-013540A0	8	33	GBR-015260A0	12	24
GBR-01106000-A	10	1	GBR-01231000-A	4	5-1	GBR-013540A0	14	43	GBR-015280A0	12	21
GBR-01107000	10	18	GBR-01233000	4	45	GBR-01355000-A	14	16	GBR-015290A0	12	19
GBR-011080A0	10	21	GBR-01234000	4	35	GBR-01357000	6	37	GBR-01531000	12	17
GBR-01109000	10	20	GBR-01235000	4	38	GBR-01357000	10	43	GBR-01532000	12	14
GBR-01110000	10	19	GBR-01236000	4	41	GBR-01357000	14	40	GBR-01533000	12	16
GBR-011110A0	10	23	GBR-01237000	4	42	GBR-01357000	14	58	GBR-01534000	12	36
GBR-011120A0	10	25	GBR-01238000	4	13	GBR-01359000	14	5	GBR-01535000	12	27
GBR-01114000	10	27	GBR-01240000-A	4	33	GBR-01359000	16	65	GBR-01536000	12	34
GBR-01115000	10	28	GBR-01241000	4	51	GBR-01361000	14	62	GBR-01537000	12	35
GBR-011160A0	10	30	GBR-01242000	4	52	GBR-013620A0	14	63	GBR-01538000	12	33
GBR-011170A0	10	15	GBR-01251000	10	47	GBR-01362000	14	66	GBR-01601000-A	2	12
GBR-011180A0	10	13	GBR-01252000	8	49	GBR-01363000	14	67	GBR-01602000	2	36
GBR-01119000-A	6	42									

Part No. 品番	Page 頁	Ref. No.	Part No. 品番	Page 頁	Ref. No.	Part No. 品番	Page 頁	Ref. No.	Part No. 品番	Page 頁	Ref. No.
GBR-01604000-B	2	6-1	MTJ-VH002400	12	52	SM-4031801-SB	4	37-1	SS-8660512-TP	12	20
GBR-01605000-A	2	10-1	MTJ-VH002500	12	51	SM-4032001-SB	22	13	SS-8660512-TP	12	22
GBR-01606000	2	7				SM-4040601-SB	4	15	SS-8660512-TP	12	25
GBR-01607000	2	8	NM-6030001-MB	22	15	SM-4040601-SB	4	29	SS-8660512-TP	12	29
GBR-017010A0	20	46	NM-6040000-SB	20	12	SM-4040601-SB	20	36	SS-8660810-TP	6	22
GBR-017020AA	20	1	NM-6040000-SB	20	20	SM-4040601-SB	22	36	SS-8661030-SP	12	50
GBR-017020AB	20	2	NH-6040000-SB	20	20	SM-4041201-SB	20	29	SS-9080410-SP	6	56
GBR-01702000	20	6	NH-6040000-SB	20	25	SM-4920501-SB	20	15	SS-9080410-SP	8	4
GBR-01703000	20	7	NH-6040001-SC	6	6	SM-5040601-SC	20	36	SS-9080410-SP	8	8
GBR-01705000	20	41	NH-6040001-SC	10	33	SM-6030602-SB	16	9	SS-9080410-SP	8	26
GBR-01706000	20	45	NH-6040002-SC	20	25	SM-6040602-SB	16	4	SS-9080410-SP	14	28
GBR-01709000	20	39	NH-6043212-SB	22	17	SM-6050802-SB	16	22	SS-9080410-SP	14	50
GBR-017100AA	20	21	NH-6050001-SA	16	34	SM-6051802-SB	4	8	SS-9091010-SP	2	37
GBR-017100AB	20	22	NH-6060001-SA	16	40	SM-6053502-SB	16	42	SS-9091010-SP	4	31
GBR-0171000A	20	23	NH-6060002-SB	6	4	SM-6061502-SB	6	67	SS-9091010-SP	8	50
GBR-0171000B	20	24	NH-6080001-SA	16	31	SM-6062002-SP	8	27	SS-9091010-SP	12	11
GBR-017110A0	18	16	NS-6080210-SP	2	9	SM-6065002-SB	16	29	SS-9120910-TP	6	15
GBR-01711000	18	17	NS-6080210-SP	6	45	SM-6082502-SB	16	35	SS-9121340-CP	2	14
GBR-01715000	20	11	NS-6090310-SP	2	11	SM-6083002-SB	16	45	SS-9151630-CP	6	29
GBR-01803000	20	48	NS-6090310-SP	6	19	SM-9040603-SC	20	19	SS-9151740-CP	12	6
GBR-019010A0	18	1	NS-6090310-SP	8	20	SS-1110840-SP	14	68	SS-9151740-CP	12	46
GBR-01901000	18	2	NS-6090310-SP	8	37	SS-2090510-SP	6	63	SS-9152130-CP	4	21
GBR-019020A0	18	5	NS-6090310-SP	10	26	SS-2090530-SP	6	63	SS-9152130-CP	6	28
GBR-01903000	18	3	NS-6090310-SP	10	42	SS-2090530-SP	10	17	SS-9152130-CP	6	36
GBR-01905000	18	10	NS-6090310-SP	18	8	SS-3090610-SP	18	7	SS-9152130-CP	6	65
GBR-01906000	18	6	NS-6110310-SP	6	40	SS-3090610-SP	18	9	SS-9154540-SP	18	15
GBR-01910000	18	4	NS-6110310-SP	8	3	SS-5060310-SP	22	52	SS-9156830-SP	18	12
			NS-6110310-SP	10	10	SS-5110810-SP	16	48	SS-9165530-SP	18	18
			NS-6110310-SP	22	46	SS-5150510-SP	16	25	SS-9282540-CP	12	39
			NS-6110420-SP	14	64	SS-6081810-SP	6	46	SS-9660720-SP	4	7
HC-0001500-00	20	3	NS-6120310-SP	2	9-1	SS-6090810-SP	4	4	SS-9660720-SP	6	54
HG-0005200-00	20	42	NS-6120310-SP	4	16	SS-6091210-TP	14	60			
HP-1A32PLC-12	22	9	NS-6120310-SP	8	18	SS-6111210-SP	10	29	WP-0320500-SF	16	10
HP-1A43PEC-12	20	47	NS-6150310-SP	10	41	SS-6111210-SP	14	49	WP-0330500-MB	4	14
HW-5F18S12-28	22	20	NS-6150310-SP	18	14	SS-6121010-SP	4	17	WP-0330500-MB	4	36-1
HW-5F18S12-48	22	6	NS-6160520-SP	18	22	SS-6121010-SP	4	30	WP-0330500-MB	20	43
HW-5F18S16-A8	20	51	NS-6740510-SP	14	23	SS-6121220-SP	22	49	WP-0330500-OE	14	28-1
						SS-6122030-SP	4	19	WP-0330501-SB	22	14
MAI-15040000	18	24				SS-7090520-TP	2	24	WP-0430800-SF	16	5
MAI-15041000	20	10	PS-0200101-KH	16	37	SS-7090520-TP	2	29	WP-0430801-SC	20	27
MAO-11512000	22	7	PS-0400141-KH	4	23	SS-7091480-SP	2	5	WP-0430801-SC	20	30
MAO-11514000	4	39	PS-0400151-KH	6	48	SS-7110340-SP	22	41	WP-0450000-SB	6	9
MAO-11514000	22	10	PS-0600121-KH	16	46	SS-7110350-SP	16	23-3	WP-0450500-SA	4	32
MAO-11532000	20	52	PT-0402000-CH	4	9	SS-7110740-TP	22	33	WP-0450501-SB	20	27
MAO-11602N00	4	34	PT-0402000-CH	6	66	SS-7111120-SP	14	69	WP-0450501-SB	20	30
MAO-12502000	22	27	PT-0402000-CH	14	34	SS-7111120-SP	22	26	WP-0480856-SB	22	37
MAO-12503000	22	30				SS-7112420-SP	6	41	WP-0480856-SB	22	31
MAO-12504000	22	29	RC-2500001-KP	10	3	SS-7112420-SP	8	1	WP-0501016-SC	4	48
MAO-12518000	22	34	RE-0150000-KP	14	8-1	SS-7112420-SP	14	42	WP-0501016-SB	14	65
MAO-14506000	20	40	RE-0250000-KO	16	19	SS-7150940-SP	2	19	WP-0501016-SP	2	16
MAO-16006000	20	31	RE-0250000-KO	22	43	SS-7151210-SP	22	38	WP-0612056-SB	2	45
MAO-16007000	20	28	RE-0400000-KO	14	26	SS-8090540-SP	14	12	WP-0612056-SB	18	13
MAO-51503000	22	11	RE-0800000-KO	12	45	SS-8090540-SP	14	22	WP-0612066-SP	6	10
MAO-71515000	22	28	RE-0901110-KO	22	23	SS-8110520-TP	8	10	WP-0621016-SB	12	47
MAT-01242000	20	35	RO-6465701-00	6	13	SS-8110520-TP	8	32	WP-0621016-SB	22	39
MAT-01253000	20	32				SS-8110520-TP	8	34	WP-0641600-SF	16	28
MAT-01254000	20	17				SS-8110520-TP	8	36	WP-0651001-SB	18	19
MAT-01255000	20	18	SD-0450211-SP	4	24	SS-8110520-TP	8	42	WP-0751576-SB	18	20
MAT-01263000	20	14	SD-0500251-SP	10	48	SS-8110520-TP	8	44	WS-0300002-KN	4	36
MAT-80115T00	22	19	SD-0500301-SP	2	4	SS-8110520-TP	8	46	WS-0310702-KS	4	36
MAT-80142T00	20	38	SD-0530221-SP	14	56	SS-8110520-TP	10	5	WS-0310702-KS	20	4
MAT-80158T00	22	8	SD-0550211-SP	22	45	SS-8110520-TP	12	8	WS-0310702-KS	20	33
MAT-81126T00	18	23	SD-0550301-SP	2	17	SS-8110520-TP	12	10	WS-0410002-KN	4	28
MAT-81131T00	20	50	SD-0600321-SP	8	23	SS-8110520-TP	12	41	WS-0410002-KN	4	50
MAT-81131T00	22	3	SD-0600402-TP	8	24	SS-8110520-TP	14	14	WS-0410002-KR	6	7
MAZ-025010A0	22	16	SD-0640391-TP	2	32	SS-8110520-TP	14	44	WS-0410002-KR	6	16
MAZ-025010B0	22	2	SD-0790602-SP	10	11-1	SS-8150510-TP	2	15	WS-0410002-KR	8	19
MAZ-025010C0	22	1	SK-3452500-SC	20	16	SS-8620610-SP	6	52	WS-0410002-KR	10	36
MAZ-02502000	22	35	SL-4030681-SF	20	5	SS-8660512-TP	4	11	WS-0411002-KB	20	13
MAZ-02503000	22	40	SL-4030881-SF	20	34	SS-8660512-TP	6	18	WS-0411002-KB	20	26
MAZ-02504000	22	44	SL-4030881-SF	20	44	SS-8660512-TP	10	14	WS-0411022-SB	22	18
MAZ-02505000	22	47	SL-4041281-SF	20	29	SS-8660512-TP	10	16	WS-0441040-KP	16	23-2
MAZ-02506000	22	50	SL-6051012-SB	16	17	SS-8660512-TP	10	16	WS-0451040-KP	22	32
MAZ-02507000	22	51	SM-4030501-SB	20	5	SS-8660512-TP	10	22	WS-0510002-KS	16	41
MAZ-02508000	4	49	SM-4030801-SB	20	34	SS-8660512-TP	10	24	WS-0521010-KP	22	48
MAZ-02508000	20	53	SM-4030801-SB	20	44	SS-8660512-TP	10	31	WS-0610002-KN	4	6
MAZ-02508000	22	24	SM-4031001-SC	4	37-2	SS-8660512-TP	10	39	WS-0610002-KS	16	39
MTJ-VH00000A	12	53	SM-4031601-SB	22	12	SS-8660512-TP	12	3	WS-0651510-KP	18	21
MTJ-VH000000	12	54	SM-4031601-SF	4	37	SS-8660512-TP	12	5	WS-0820002-KS	16	44