

## 目录 CONTENTS

工业缝纫机伺服控制系统用户手册 .....	- 2 -
1. 产品规格 (SPECIFICATIONS) .....	- 2 -
2. 机头安装方法 (INSTALLATION OF MACHINE HEAD) .....	- 3 -
3. 加油方法 (LUBRICATION) .....	- 3 -
4. 机针安装方法 (ATTACHING THE NEEDLE) .....	- 4 -
5. 针杆罩的安装方法 (ATTACHING THE NEEDLE BAR GUARD) .....	- 4 -
6. 纽扣盘的安装方法 (ATTACHING THE BUTTON TRAY ASSEMBLY) .....	- 4 -
7. 上线穿线方法 (THREADING THE MACHINE) .....	- 5 -
8. 线张力 (THREAD TENSION ADJUSTMENT) .....	- 5 -
9. 线调节杆的调整 (ADJUSTMENT OF THE THREAD PULL -OFF LEVER) .....	- 6 -
10. 针导向器的位置 (POSITION OF THE NEEDLE GUIDE) .....	- 6 -
11. 机针和弯针的关系 (NEEDLE -TO-LOOPER RELATION) .....	- 6 -
12. 爪扣装置的高度 (HEIGHT OF THE BUTTON CLAMP) .....	- 7 -
13. 拨针器的调整 (ADJUSTMENT OF THE NIPPER) .....	- 8 -
14. 压脚压力的调节 (WORK PRESSING FORCE) .....	- 8 -
15. 压脚压力的调节 (ADJUSTMENT OF THE BUTTON CLAMP STOP LEVER) ...	- 8 -
16. 松线同步时间的调整 (TIMING OF THREAD TENSION RELEASE) .....	- 9 -
17. 切线装置 (AUTOMATIC THREAD TRIMMER) .....	- 10 -
18. 电控部分 (ELECTRIC CONTROL PART) .....	- 10 -
19. 第1章 产品接口 (CHAPTER 1 PRODUCT INTERFACE) .....	- 12 -
1.1 接口插头连接 (INTERFACE PLUG CONNECTION) .....	- 12 -
1.2 接线与接地 (WIRING AND GROUNDING) .....	- 13 -
20. 第2章 操作面板使用说明 (CHAPTER 2 OPERATION PANEL INSTRUCTIONS) ....	- 13 -
2.1 操作面板的显示说明 (THE OPERATION PANEL DISPLAY) .....	- 13 -
2.2 操作面板各按键功能说明 (OPERATION PANEL KEY-PRESS FUNCTION) .	- 14 -
22. 第3章 系统参数设置说明 (SYSTEM PARAMETER SETUP INSTRUCTION) .....	- 16 -
3.1 技术员参数表 (THE TECHNICIAN PARAMETER TABLE) .....	- 16 -
3.2 系统员参数表 (SYSTEM PARAMETER TABLE) .....	- 18 -
3.3 监控参数表 (MONITORING PARAMETER TABLE) .....	- 18 -
3.4 故障代码表 (THE FAULT CODE TABLE) .....	- 19 -
23. 第4章 特殊功能操作说明 (SPECIAL FUNCTION INSTRUCTION) .....	- 22 -
4.1 上停针位调整 (THE NEEDLE ON AN ADJUSTMENT) .....	- 22 -
4.2 一键恢复机头厂家参数值 (A KEY PARAMETER VALUES) .....	- 22 -
4.3 自动测试 (AUTOMATIC TEST) .....	- 23 -
24. 零件样本 (THE SAMPLE PARTS) .....	- 25 -

# 工业缝纫机伺服控制系统用户手册

## 前言



注意

使用前请仔细阅读本用户手册及所搭配的缝制设备说明书，配合正确使用，并须由接受过专业培训的人员来安装或操作。

### 安全说明

- 在使用本产品之前，请先阅读《产品说明书》及所搭配的缝纫机机械说明书。
- 本产品必须由接受过专业培训的人员来安装或操作。
- 请尽量远离电弧焊接设备，以免产生的电磁波干扰本控制器而发生误动作。
- 请不要在室温45°以上或者0°以下的场所使用。
- 请不要在湿度30%以下或者95%以上或者有露水和酸雾的场所使用。
- 安装控制箱及其他部件时，请先关闭电源并拔掉电源插头。
- 为防止干扰或漏电事故，请做好接地工程，电源线的接地线必须以牢固的方式与大地有效连接。
- 所有维修用的零部件，须由本公司提供或认可，方可使用。
- 在进行任何保养维修动作前，必须关闭电源并拔掉电源插头。控制箱里有高压危险，必须关闭电源五分钟后方可打开控制箱。
- 本手册中标有  符号之处为安全注意点，必须注意并严格遵守，以免造成不必要的损害。

## 1. 产品规格 (SPECIFICATIONS)

控制器型号	AHE59
电源电压	AC 220±20% V
输出功率	550W
电机低速最大转矩	3Nm
电源频率	50HZ/60HZ
电机最大转速 (r/min)	最高1500 (常用1300~1400)
针数	8针、16针、32针 (更改凸轮后可6、12、24针)
送布量	横向送布2.5~6.5mm 纵向送布0、2.5~6.5mm
纽扣尺寸	10~28mm
机针	TQ×1#16 (#14~#18) TQ×7#16 (#14~#20)
机油	NO.1新机油

The controller model	AHE59
The power supply voltage	AC 220±20% V
The output power	550W
Low-speed maximum power frequency motor	3Nm
Power frequency	50HZ/60HZ
Sewing speed	最高1500 (常用1300~1400)
Number of stitches	8针、16针、32针 (更改凸轮后可6、12、24针)
Feed amount	横向送布2.5~6.5mm 纵向送布0、2.5~6.5mm
Button size	10~28mm
Needle	TQ×1#16 (#14~#18) TQ×7#16 (#14~#20)
Lubricating oil	NO.1新机油

## 2.机头安装方法 (INSTALLATION OF MACHINE HEAD)

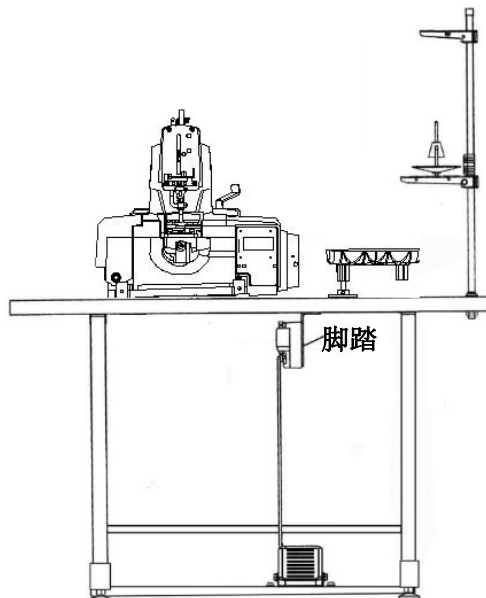
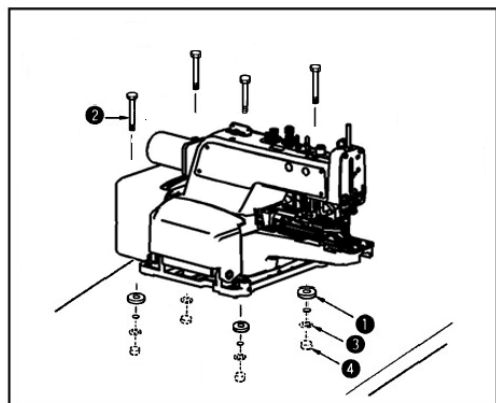

把防震橡胶垫①放到台板上，然后把机头放在上面，用固定螺丝②、垫片③、螺母④固定好。

(Put rubber cushion ① on the table, place the machine head on the rubber cushion and fix it to the table using screws ②, plain washers ③ and nuts ④.)

## 3.加油方法 (LUBRICATION)

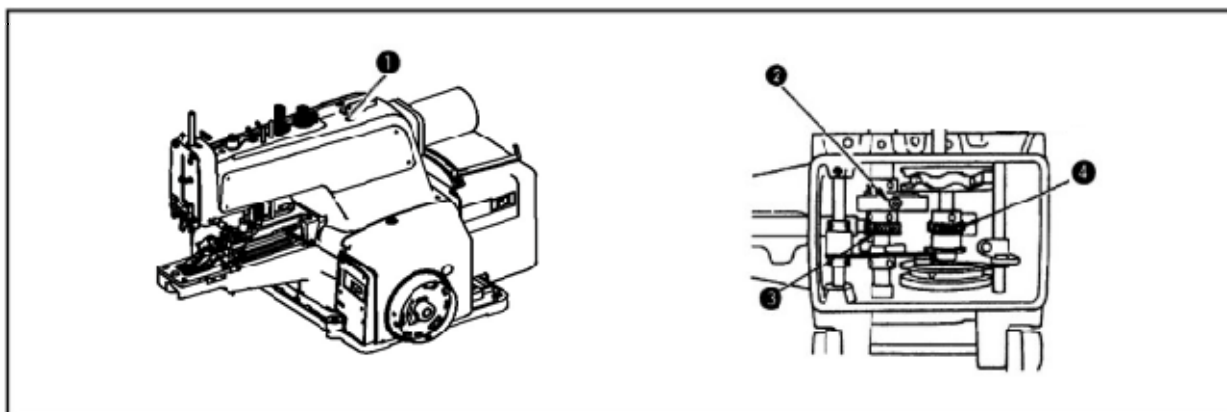

(1) 把No. 1新机油加入到①所指的孔处。(每周1~2次)

(2) 拧松安装螺钉，放倒缝纫机，把润滑脂加到螺旋齿轮③和涡轮④上。

(3) 每周检查一次机座安装台内的加油毛毡上面是否吸满油，不够时请加油。同时请往曲轴部②上也加油

(1) Apply New Dwfrifx Oil No. 1 to the components shown by the arrows .

(once or twice a week)

(2) Loosen connecting screw ①, tilt the head backward and apply some grease to driving worm gear ③ and gear ④ .

(3) Check , approximately once a week , that oil amount is sufficient to reach the top of the oil felt placed inside the bed mounting base .If the amount of oil is insufficient, add an adequate amount of oil, At the time , also apply oil to crank rod②.

#### 4.机针安装方法 (ATTACHING THE NEEDLE)

★标准机针为使用TQ×7#14

(1) 拧松机针固定螺钉①，手拿机针把机针②长沟转到面前。

(2) 把机针②插进针杆孔的深处。

(3) 拧紧机针固定螺丝①。

★Use a standard needle of TQ×7#14

(1) Loosen screw ①.

(2) Insert needle ② up into the needle hole in the needle bar until it comes in contact with the deepest end of the needle hole.

(3) Tighten screw ① firmly.

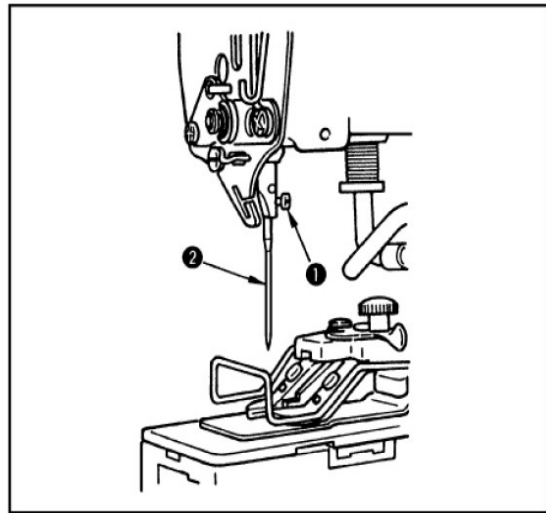

#### 5.针杆罩的安装方法 (ATTACHING THE NEEDLE BAR GUARD)

(1) 拧松固定螺丝②，并把它卸下。  
(2) 把针杆罩①安装到第二道线器的下面。

(3) 用固定螺丝②固定起来。

(1) loosen screw ② and remove the thread guide No. 2.

(2) Place needle bar guard ① under the thread guide No. 2.

(3) Fix the thread guide No. 2 and needle bar guard ① together using screw ②.

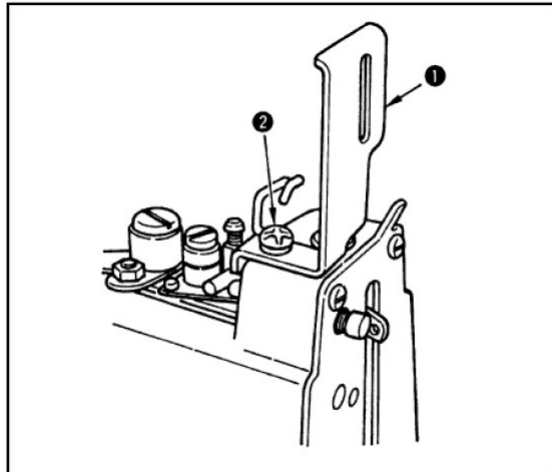

#### 6.纽扣盘的安装方法 (ATTACHING THE BUTTON TRAY ASSEMBLY)

把纽扣盘①插进机座前部的孔上，并把固定螺丝②拧紧固定。

Insert the posts of button tray ① in the hole on the right of the machine sub-base and tighten each setscrew ②.

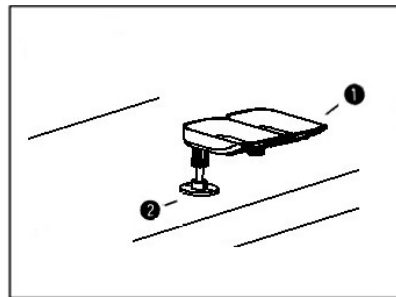

## 7.上线穿线方法 (THREADING THE MACHINE)

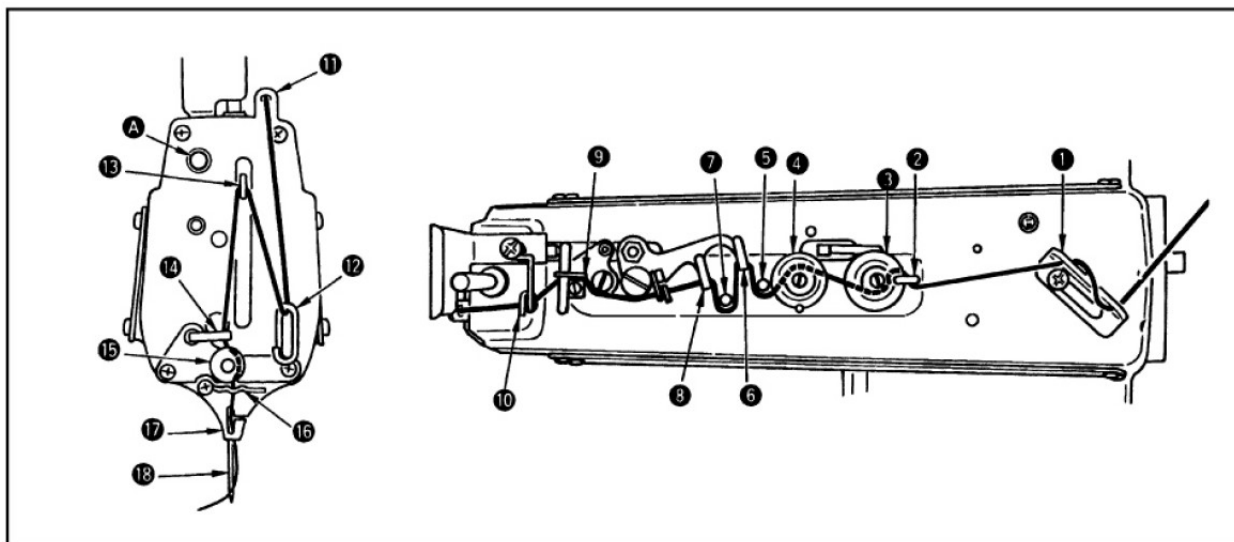

如图所示的顺序进行穿线，从针孔的前侧向后侧按松线螺母A，把线拉出约60~70mm左右。(Thread the machine in order of ①to18 as illustrated and pass the thread through the needle eye from the front for 60 to 70 mm as you depress nipper releasing knurled thumb nut A)

## 8.线张力 (THREAD TENSION ADJUSTMENT)

第一线张力螺母①是调整钉扣强度用的，仅能调节极小的张力。

第二线张力调整螺母②是调整背面的紧线程度的，其张力比第一线张力螺母①强，根据使用的机线、布料、纽扣厚度等情况，进行调整。

向右转动各线张力螺母之后，线张力变强，向左转动则张力变弱。

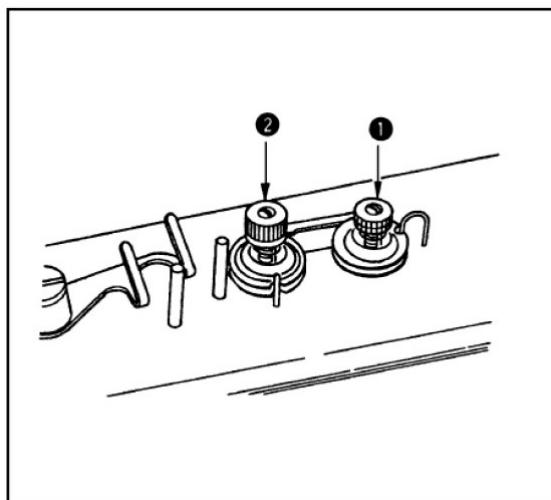

Tension post No.1① is used to adjust the thread tension to sew on the button and a relatively low tension will be enough. Tension post No.2 ②is used to adjust the thread tension applied to the root of the button sewing stitches.

This tension must be determined according to the type of thread ,fabric and thickness of the button and must be higher than that of tension post No.1①.turn the tension nuts clockwise to increase or counterclockwise to reduce the thread tension .

### 9.线调节杆的调整 (ADJUSTMENT OF THE THREAD PULL -OFF LEVER)

调节线调节杆时①时，请把螺丝刀插进左侧面板上的孔中，拧松固定螺丝②，然后左右移动调节杆的活动滑块③进行调整。缝制结束，如果线头从A部前头的孔中露出时，请把线调节杆活动滑块③向左移动，如果线头从B部箭头的孔中露出时，请把滑块向右移动，不让线头露出来。

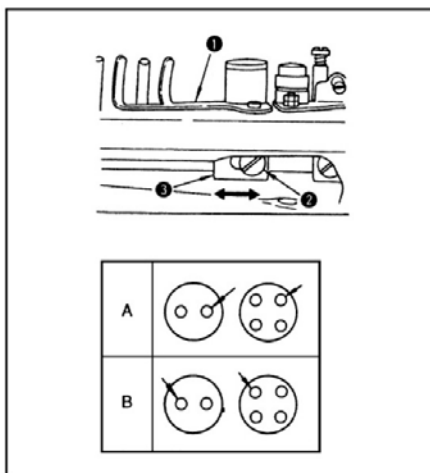

To adjust the thread pull-off lever①, insert a screwdriver through an opening in the machine arm side cover (left), loosen screw ② and adjust the position of nipper bar block (rear)③ to the left or the right . If the end of the thread is drawn from arrow hole A in the button after sewing ,change the position of nipper bar block (rear)③ to the left .Move the lever to the right when the thread end comes out from arrow hole B .

### 10.针导向器的位置 (POSITION OF THE NEEDLE GUIDE )

在针杆最下点，拧松螺丝②，左右移动针导向器①，把机针和针导向器①的间隙调整为0.05~0.1mm

Loosen screw② and provide a 0.05 to 0.1mm clearance between the needle guide ① and the needle by moving the needle guide ① to the left or the right when the needle is in the lowest position .

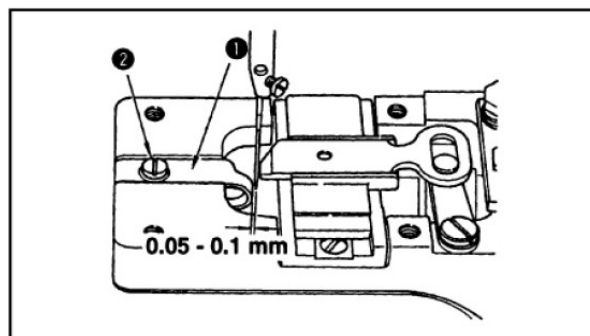

### 11.机针和弯针的关系 (NEEDLE -TO-LOOPER RELATION)

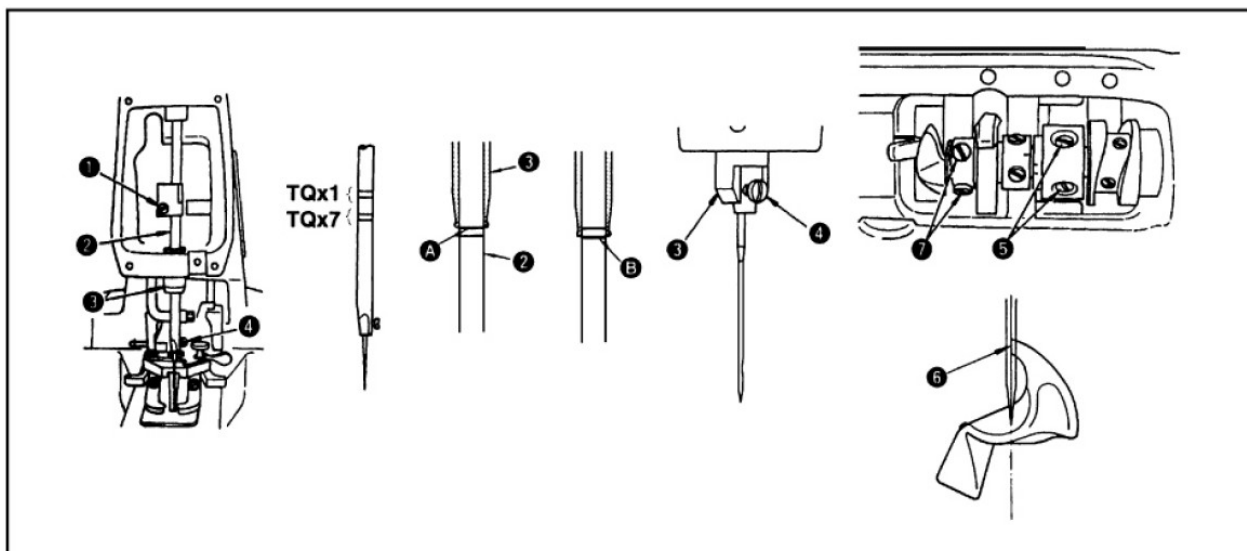

★机针和弯针按照如下方法进行调整

- (1) 按转动方向驱动手轮，让针杆落到最下点，然后拧松固定螺丝①（决定针杆高度）
- (2) TQx1机针时，使用上方的2条刻线，TQx7机针时，使用下方的2条刻线，把其中的上刻线A对准针杆下端块③的下端，然后拧紧固定螺丝①。这时应让机针固定螺丝4进入到避免与针杆下端块③相碰的沟槽里。（决定弯针的位置）
- (3) 拧松固定螺丝5，转动手轮，把针杆②的2条一组的刻线中的下刻线B对准针杆下端块③的下端。
- (4) 在此状态，把弯针的针尖6对准机针的中心，然后拧紧固定螺丝5.
- (5) 拧松固定螺丝7，把弯针间隙调整为0.01~0.1mm，在拧紧螺丝7.

★ Adjust the needle-to-looper relation as follows :

- (1) Depress the pedal fully forward ,turn the needle driving pulley in the normal sewing direction to bring down the needle bar to the lowest point of its stroke and loosen screw①  
(Adjusting the needle bar height )
- (2) Adjust the height of the needle bar using top two lines engraved on the needle bar for the TQx1 needle and using the bottom two lines for the TQx7 needle .Align the upper line A with the bottom end face of needle bar bushing (lower)③ and tighten screw ① in the way that needle clamp screw 4 rests in the slot of the needle bar bushing (lower )
- (3) Looper screws 5 and turn by hand the needle driving pully until lower line B of two lines aligns with the bottom end face of needle bar bushing (lower)③
- (4) By keeping the machine in this state ,align looper blade 6 with the center of the needle and tighten screws 5
- (5) Loosen screws 7 and provide a 0.01to 0.1 mm clearance between the looper and the needle .tighten screws7.

## 12.爪扣装置的高度 (HEIGHT OF THE BUTTON CLAMP)

在断开位置，纽扣爪脚①的地面和布压脚下板②上面的间隔A,1377E标准为9mm。

**The standard clearance A between the bottom face of button clamp jaw lever ① and the top face of feed plate ② is 9 mm for 1377E.Loosen screw ③ and adjust the height of button clamp lifting hook4.**

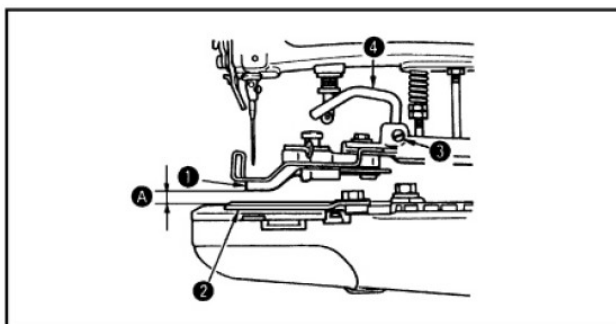

### 13. 拨针器的调整 (ADJUSTMENT OF THE NIPPER)

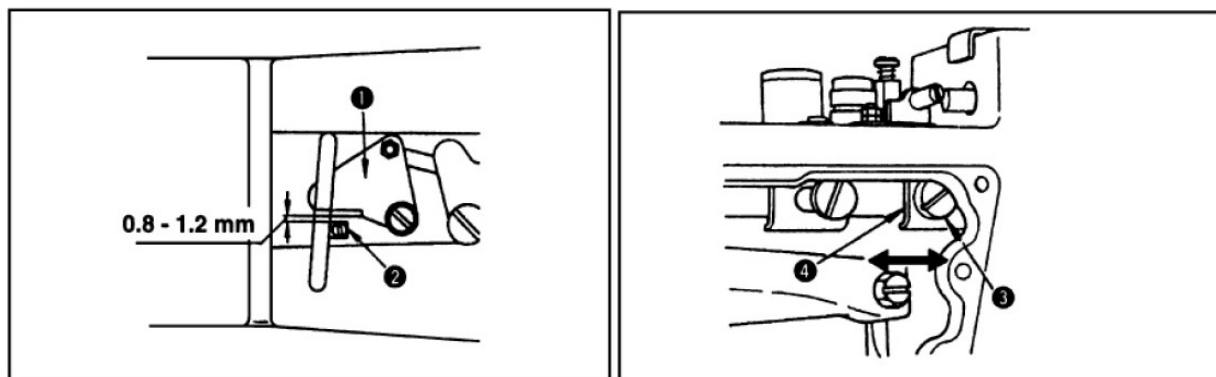

运转时，把拨针器的方块②和拔①的间隙调整为0.8~1.2mm，不让拨针器①压住机线。调节方法是，拧松固定螺钉③，左右移动拨针器活动滑块4。

Provide a 0.8 to 1.2 mm clearance between nipper ① and nipper block ② to prevent the nipper from nipping the thread while stitching. Loosen screw ③ and move nipper bar block 4 to the left or the right.

### 14. 压脚压力的调节 (WORK PRESSING FORCE)

压脚的压力，以在转动螺母①个螺母的下端和压脚压力调节杆②的螺丝部间隙为4-5mm时为准。

**The standard work pressing force is obtained by providing a 4 to 5 mm clearance between the bottom face of nut ① and the bottom end of the screw of pressure adjusting bar ②.**

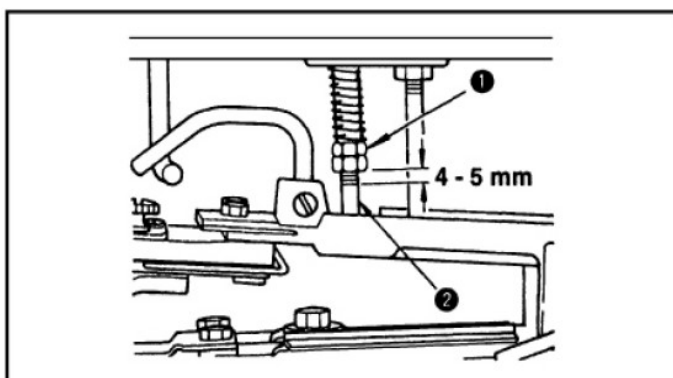

### 15. 压脚压力的调节 (ADJUSTMENT OF THE BUTTON CLAMP STOP LEVER)

在断开状态，拧紧固定螺丝①，用爪脚打开拨杆②开关打开爪脚③，把纽扣设定到正确的位置。让纽扣容易放进取出，然后拧紧螺丝①。

**Set the machine for stop-motion state, loosen clamp screw ①, place a button correctly in the sewing position and adjust button clamp stop lever ② to permit the button properly to rest on button clamp jaw levers ③. tighten clamp screw ① after determining the distance between the left and right jaw levers ③.**

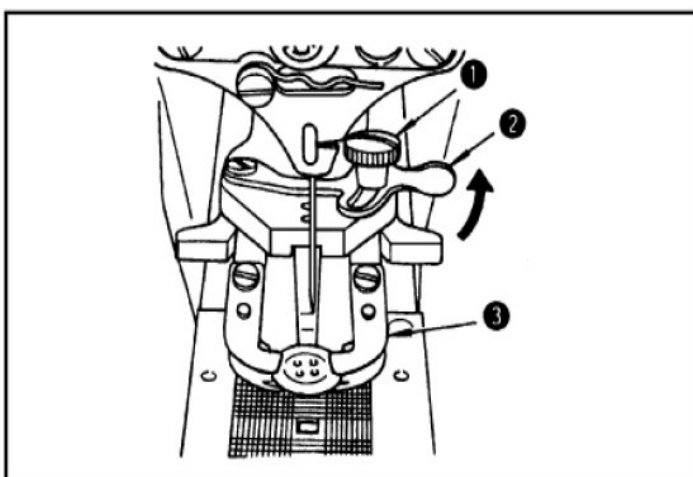



## 16. 松线同步时间的调整 (TIMING OF THREAD TENSION RELEASE)

沿箭头方向拉机线，转动手轮，有一个第二线张力盘浮起，机线迅速拔出的点。此时，从针杆上端块上面到针杆上面到针杆上端的高度为T1377E使用53~56mm时为标准。

特别是频繁发生下列现象时，进行如下调节：

拧松螺母①，把螺丝刀插入第二线张力杆，沿箭头方向转动的话，针杆高度变低，向相反方向转动，则变高。

现象	针杆高度
1.布料里侧的紧线不好时	稍稍高一点
2.断开时，机针中途断线时	稍稍高一点
3.经常断线时	稍稍低一点

Turn the needle driving pulley as you draw the thread in the direction of the arrow as illustrated and you will find a point at which the tension disc on the tension post No.2 release the thread. At this moment, the standard distance from the top end of the needle bar to the top of the needle bar bushing is 53 to 56 mm for T1377E. Perform the following adjustments especially when the undermentioned troubles occur frequently.

Loosen nut ①, insert the blade of a screwdriver to the top slot of the tension post No.2 and turn it in the direction of the arrow to lower the needle bar, (to reduce the said distance), and vice versa. Your adjustments is required when following troubles are frequently;

Phenomenon	Height of needle bar
1. when the stitch made on the wrong side of the workpiece is too loose;	Make the needle bar slightly higher
2. When the thread is broken at the time of stop-motion;	Make the needle bar slightly higher
3. When the thread is broken frequently	Make the needle bar slightly lower

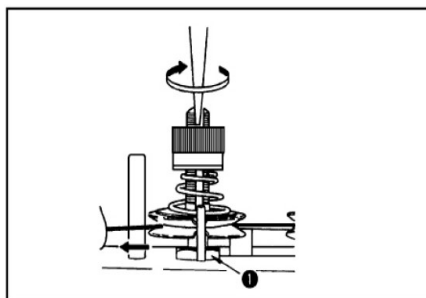

## 17. 切线装置 (AUTOMATIC THREAD TRIMMER)

### ★移动刀位置的调整

压脚上升到最高处时，切线连接板（前）①和针板②槽沟面的间隔标准为12.5mm。调整到12.5mm时，请使用附属品的定位尺③，放到缝纫机，卸下防油板，拧松螺母4（2个），前后移动连接螺丝5，进行调整。另外，拧紧螺母4时，请注意切线连接头6应基本保持水平。

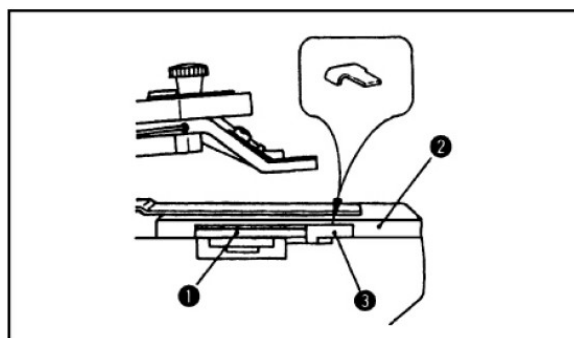

### ★Position of the moving knife

When the machine stops in the state of “stop -motion” and its button clamp assembly rests in the highest position ,there must be a standard clearance of 12.5mm between thread trimming connecting link (front)① and the end face of the slit in throat plate ②.this clearance is determined by gauge 3 which is stored in the accessory box ;tilt the head backwards ,remove the bed oil shield , Loosen two nuts 4 and adjust the clearance by moving connecting screw 5 in the axial direction .When you tighten two nuts 4,ensure that joint 6stays in the horizontal position .

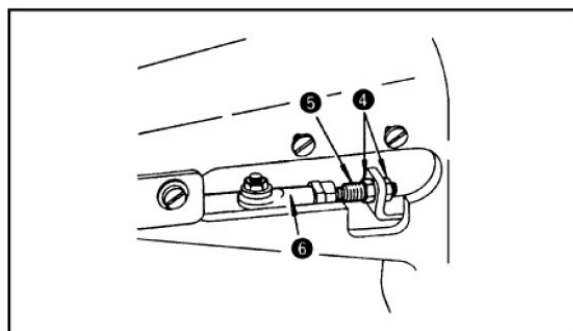

### ★L型提升杆的安装方法

按移动反弹弹簧②、分离垫片③、分离垫4、分离垫片5的顺序安装到L型提升杆上。确定完全分离之后让机梁的凸部和分离垫片端面紧密结合，不要有任何松动，用螺丝6拧紧固定。

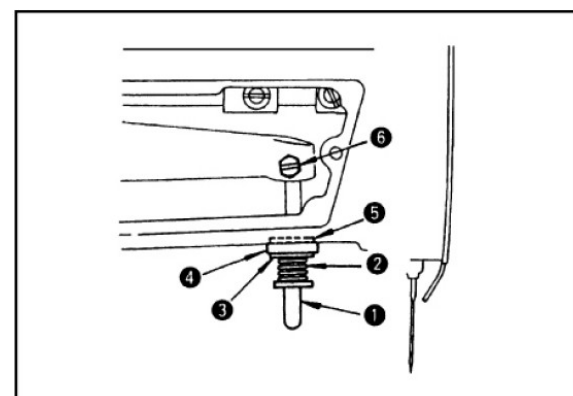
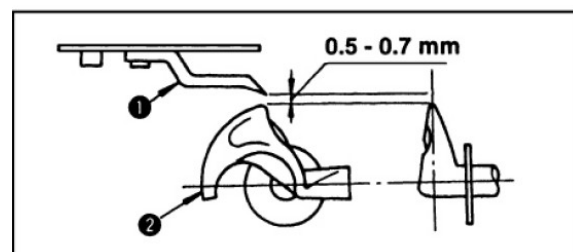

# 电控部分

(Electric control part)

# 第1章 产品接口

## 1.1 接口插头连接

将脚踏板及机头的各连接插头安插到控制器后面对应的插座上如图1-1所示，各插座名称如图1-2所示。连接好，请检查插头是否插牢。例图1-2所示。连接好，请检查插头是否插牢。①LED灯和传感器插座；②抬压脚电磁铁插座；③脚踏板插座。

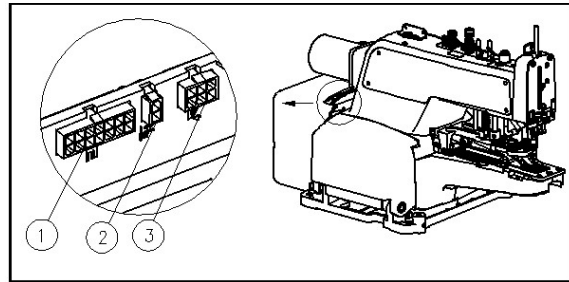

例图1-1 AHE 系列控制器图

Connect the pedal and the nose or the plug placed behind the controller corresponding to the socket as shown in figure 1-1, the name of the socket as shown in figure 1-2. Connection is good, please check whether the plug is stuck. Example shown in figure 1-2. Connection is good, please check whether the plug is stuck. LED lights and sensors socket; (2) the presser foot electromagnet socket; The pedals socket.



图1-2 控制器接口定义

⚠: 使用正常的力量插不进去时，请检查插头与插座是否匹配，插入方向或针的方向是否正确！照明灯接口和传感器接口都是1\*2 的接口，请注意区分。

⚠: When using normal power plug is not in, please check whether the plug and socket match, the direction of the needle insertion direction or whether it is right! Light interface and sensor interfaces are 1 \* 2, please pay attention to distinguish.

## 1.2 接线与接地(Wiring and grounding )

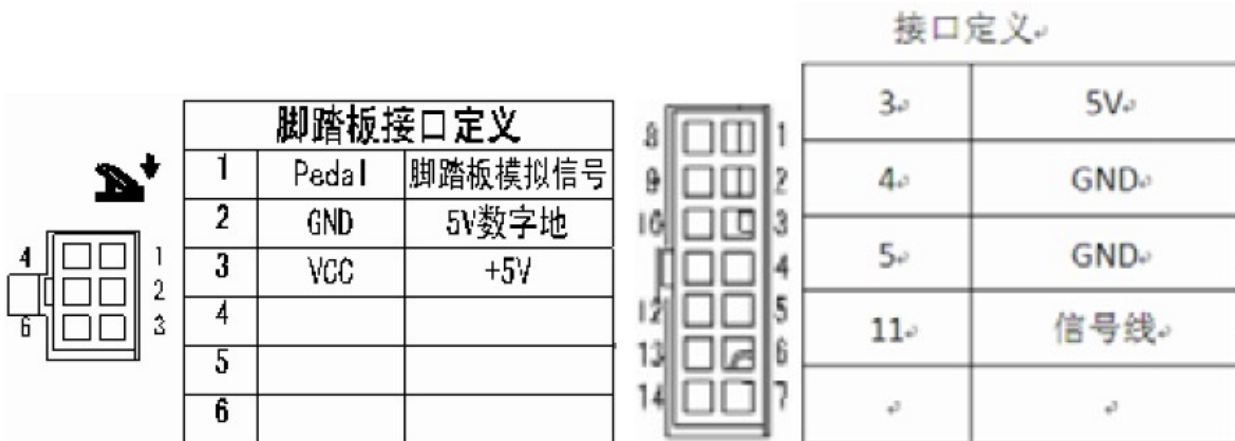
必须要做好系统的接地工程，请合格的电气工程人员予以施工。产品通电及投入使用前，必须确保电源插座AC 输入端已安全可靠的接地。系统的接地线为黄绿线，该地线请务必可靠连接至电网安全保护接地上，以保证安全使用，并可防止出现异常情况。

Must prepare system grounding engineering, please qualified electrical engineering construction. Product power and put into use before, must ensure that the power socket AC input is safe and reliable grounding. Grounding line is yellow green line in the system, the ground please reliable connection to the network security protection on the ground, to ensure the safe use, and can prevent the abnormal situation.

⚠️: 所有电源线、信号线、接地线等接线时不要被其它物体压到或过度扭曲，以确保使用安全！

All power cables, signal lines, grounding line don't pressed to by other objects such as wiring or excessive distortion, to ensure the safety of use!

## 第 2 章 操作面板使用说明(Chapter 2 operation panel instructions )

### 2.1 操作面板的显示说明(The operation panel display)

根据系统工作状态，操作面板的液晶屏模块将显示当前的缝纫模式、各种参数、前/后固缝设置，以及抬压脚、停针位、剪线、慢速起缝等液晶字符。H-12 操作面板液晶屏功能图标显示说明如下所示。

Based on the system working status, operation panel of the LCD panel module will display the current sewing patterns, all kinds of parameters, before/after solid seam Settings, as well as the presser foot, needle, thread, such as slow up seam LCD characters. H - 12 operation panel LCD screen function icon is displayed as shown below.



图2-1 H-12 操作面板外观界面



图2-2 H-12 操作面板液晶显示屏图示



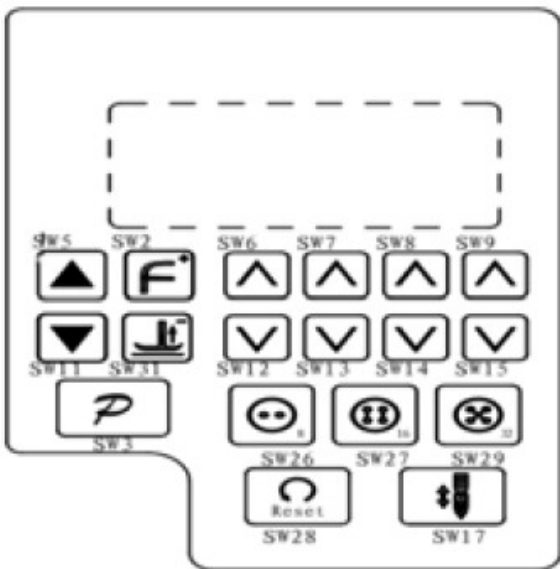



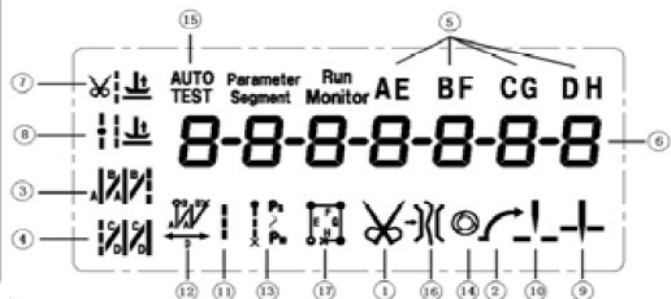



索引	图标	描述	索引	图标	描述
1		软启动功能	4		多段缝
2		计数/参数值显示	5		自由缝
3		剪线后抬压脚	6		自动测试

The index	icon	description	The index	icon	description
1		Soft start function	4		Many pieces
2		Count/parameter values displayed	5		Free seam
3		After trimming the presser foot	6		Automatic test

## 2.2 操作面板各按键功能说明

序号	外观	名称	功能描述
1		确认及返回键	按键输入参数确认键，并回退到上一级菜单直至操作员缝纫工作状态。此外，还可与其它按键同时按下实现组合功能，可进入高级参数与功能设置。
2		软启动	按下该键，液晶屏图标亮，表明软启动有效，再按一下该图标熄灭，表明关闭软启动功能。
3		抬压脚	按下该键，液晶屏图标显示，同时抬压脚电磁铁抬起，再按一下该按键，液晶屏图标显示没有
4		8 针键	按下该键，系统进入 8 针缝纫模式
5		16 针键	按下该键，系统进入 16 针缝纫模式
6		32 针键	按下该键，系统进入 32 针缝纫模式
7		复位键	按下该键，系统自动寻找原点
8		速度增 减键	长按可以快速调整系统的运行速度。此外在进入参数设置模式，通过和 P 键联合使用可以在几种参数设置模式下切换。

## 2.2 Operation panel each key-press function description

The serial number	appearance	name	Functional description
1		Confirm and Return key	Key input parameters confirmed a key, and backs up one level menu until the sewing operator working condition. In addition, but also with other key press at the same time Implement composite function, can enter advanced parameters and feature set.
2		Soft start	Press the key, LCD screen icon  bright, showed that the soft start, effective click the icon to go out again, show closed soft start function.
3		Presser Foot Lift	Press the key, LCD screen icon is displayed  , electromagnet presser foot lift at the same time, press the button again, the LCD panel icon shows no  .
4		8 pin key	Press the button, the system into 8 needles sewing patterns
5		16 pin key	Press the button, the system into 16 needles sewing patterns
6		32 pin key	Press the button, the system into 32 needles sewing patterns
7		Reset button	Press the button, the system automatically search for the origin
8		The speed of increase or decrease in key	Long press can quickly adjust system. Further into the parameters set pattern, through and the P key combination mode switch can be set on a few parameters.

## 第 3 章 系统参数设置说明

### 3.1 技术员参数表









<p>1、 长按  键，可修改技术员参数表；</p> <p>2、 按下对应的   键和   或  键和  键可选择参数编号并更改相应的参数值；</p> <p>3、 最后按下  键，即退出参数设置模式，回到缝纫工作模式。</p>				
参数编号	参数范围	典型值	参数描述	备注
100	100-800	200	起缝速度	速度
101	200-5000	1500	自由缝最高速（全局最高限速）	
102	200-5000	3000	多段缝最高速；自动测试速度	
104	200-800	200	Reset 速度	
108	100-800	400	慢速起缝速度	
13A	0-800	300	踏板抬压脚确认时间	踏板参数
13E	0-800	5	压脚抬起延迟时间	
140	0/1	0	上电自动找停车位： 0：不找；1：找	习惯设定
149	0-10	0	压脚缓放开关（0 关闭缓放，非0 为缓放开启）	
164	-		密码	
165	XXXX		恢复出厂设置	

注：16X 参数操作须长时间按住  键大约3-5 秒。



## Chapter 3 system parameter setup instructions

### 3.1 The technician parameter table

<p>1. Long press , can modify the technician parameter table;</p> <p>2. Press the corresponding key   and   or  and  keys can choose parameter number and change the corresponding parameter values;</p> <p>3. Finally to press the key , exit parameters setting mode, back to the sewing pattern.</p>				
The serial number	range	Typical values	Parameters to describe	note
100	100-800	200	The sewing speed	speed
101	200-5000	1500	The maximum speed limit on free seam top speed (global)	
102	200-5000	3000	Many pieces most high speed; Automatic test speed	
104	200-800	200	Reset speed	
108	100-800	400	Sewing speed slow	
13A	0-800	300	Pedal presser foot set the time	Pedal speed parameter
13E	0-800	5	Presser foot lift the delay time	
140	0/1	0	Electricity automatically find a parking space: 0: don't look for; 1: find a	Used to set
149	0-10	0	Presser foot slowly let go off (0 closed slowly, non-zero for slow opening)	
164	-		password	
165	XXXX		Restore the factory Settings	

Note: 16 x parameter operation is to be a long time holding down the key  about 3 to 5 seconds.

### 3.2 系统员参数表

参数编号	参数范围	典型值	参数描述
244	0-800	100	放压脚延迟时间 (ms)
249	0-600	120	剪线后自动抬压脚抬起保持时间100ms
24A	0-60	7	8针设置
24B	0-60	15	16针设置
24C	0-60	31	32针设置
24D	0/1	1	针数切换时自动复位
24E	0/1	1	后踩踏板时是否停车, 1为停车
278	1-500	150	抬压脚全出力时间
279	1-100	3	抬压脚chopping开通时间
27A	1-100	5	抬压脚chopping关闭时间
27B	1-600	10	抬压脚chopping关闭时间

### 3.2 System parameter table

1. Long hold keys  $\square$  to electricity, enter the technician lxx parameter table ;











2. And then press the key  $\square$  not to put at the same time, press the  $\wedge$  or  $\vee$  key, member can modify system parameter table 2xx;

3. Press the corresponding key  $\blacktriangle$   $\square$  number and  $\blacktriangledown$   $\square$  change parameters, key and key can modify;

4. Finally press the P button  $\square$ , that is, save and exit parameters setting mode and return to normal sewing patterns.











Parameter number	range	values	Parameters to describe
244	0-800	100	Put the presser foot delay time (ms)
249	0-600	120	Presser foot lift the hold time 100 ms
24A	0-60	7	8 needle set
24B	0-60	15	8 needle set
24C	0-60	31	8 needle set
24D	0/1	1	Automatic reset pin number when switching
24E	0/1	1	When the pedal is after parking, 1 for parking
278	1-500	150	Presser foot all output time
279	1-100	3	Presser foot chopping opening time
27A	1-100	5	Presser foot chopping closing time
27B	1-600	10	Presser foot chopping closing time

### 3.3 监控参数表

- 1、先按下  键不放，再按下  键，可进入监控模式，液晶屏默认显示 024 号参数 ；
- 2、按下对应的   键和   键或  键和  键可选择参数编号，即可实时监视对应参数变化；
- 3、最后按下  键，即退回到正常缝纫模式。

参数编号	参数描述	参数编号	参数描述	参数编号	参数描述
010	针数计数	022	相电流	027	电机累计运行时间
011	记件数	023	初始角度	028	机头交互量电压采样值
013	霍尔状态	024	机械角度	029	DSP软件版本号
020	母线电压	025	踏板电压采样值	030-037	历史故障代码
021	机头转速	026	机头传动比实际值		

### 3.3 Monitoring parameter table

1. First press the keys  , then press the key  , can enter the monitor model, parameters, 024 LCD screen display  by default;
2. Press the key   and the corresponding number   or key  or key  and key can select parameters, can real-time monitoring the corresponding parameters;
3. Finally press the P button  , that is, save and exit parameters setting mode and return to normal sewing patterns.

Parameter number	Parameters to describe	Parameter number	Parameters to describe	Parameter number	Parameters to describe
010	Pin number counting	022	Phase current	027	Total run time
011	Remember the number	023	The initial point of	028	Voltage sampling values
013	Hall state	024	Mechanical point of view	029	DSP version number
020	Bus voltage	025	Step voltage sampling values	030-037	Historical fault code
021	The nose of speed	026	Ratio of the actual value		

### 3.4 故障代码表

若系统出现报错或报警，请首先检查如下项：

- 1、先确认机器的连接线是否连接完好；
- 2、确认电控和机头是否匹配；
- 3、确认恢复出厂

是否准确。

故障代码	代码含义	解决措施
E r r - 0 1	硬件过流	关闭系统电源，30 秒后重新接通电源，控制器若仍不能正常工作，请更换控制器并通知厂方
E r r - 0 2	软件过流	
E r r - 0 3	系统欠压	断开控制器电源，检查输入电源电压是否偏低（低于176V）。若电源电压偏低，请在电压恢复正常后重新启动控制器。若电压恢复正常后，启动控制器仍不能正常工作，请更换控制器并通知厂方。
E r r - 0 4	停机时过压	断开控制器电源，检查输入电源电压是否偏高（高于264V）。若电源电压偏高，请在电压恢复正常后重新启动控制器。若电压恢复正常后，启动控制器仍不能正常工作，请更换控制器并通知厂方。
E r r - 0 5	运行时过压	
E r r - 0 6	电磁铁回路故障	关闭系统电源，检查电磁铁连线是否正确，是否有松动、破损等现象。若有则及时更换。确认无误后重启系统，若仍不能工作，请更换控制器并通知厂方。
E r r - 0 7	电流检测回路故障	关闭系统电源，30 秒后重新接通电源观察是否能正常工作。重试几次，若该故障频繁出现，请更换控制器并通知厂方。
E r r - 0 8	电机堵转	断开控制器电源，检查电机电源输入插头是否脱落、松动、破损，是否有异物缠绕在机头上。排除后重启系统仍不能正常工作，请更换控制器并通知厂方。
E r r - 0 9	制动回路故障	关闭系统电源，检查电源板上白色的制动电阻接头是否松动或脱落，将其插紧后重启系统。若仍不能正常工作，请更换控制器并通知厂方。
E r r - 1 0	HMI 通讯故障	检查控制面板与控制器的连线是否脱落、松动、断裂，将其恢复正常后重启系统。若仍不能正常工作，请更换控制器并通知厂方。
E r r - 1 1	机头停针信号故障	检查机头同步信号装置与控制器的连线是否松动，将其恢复正常后重启系统。若仍不能正常工作，请更换控制器并通知厂方。
E r r - 1 2	电机初始角度检测故障	请断电后再尝试2-3 次，若仍报故障，请更换控制器并通知厂方。
E r r - 1 3	电机 HALL 故障	关闭系统电源，检查电机传感器接头是否松动或脱落，将其恢复正常后重启系统。若仍不能正常工作，请更换控制器并通知厂方。
E r r - 1 4	DSP 读 写 EEPROM 故障	
E r r - 1 5	电机超速保护	
E r r - 1 6	电机反转	
E r r - 1 7	HMI 读 写 EEPROM 故障	
E r r - 1 8	电机过载	
E r r - 2 3	电机堵转扇区错误	断开控制器电源，检查电机电源输入插头是否脱落、松动、破损，是否有异物缠绕在机头上。排除后重启系统仍不能正常工作，请更换控制器并通知厂方。







3.4 The fault code table If the system error or alarm, please first check the following items: 1、Make sure the machine problem is in good contact; 2、Confirm that electrical control and the nose match; 3、Confirm back the factory are accurate.

Fault code	Code meaning	The measures
E r r - 0 1	Hardware flow	Shut down the system power supply, 30 seconds to connect the power supply, controller, if still doesn't work, please replace the controller and notify the manufacturer
E r r - 0 2	Software flow	
E r r - 0 3	The system under voltage	Disconnect the controller power supply, check whether the input power supply voltage is low (less than 176 v). If the supply voltage is low, after the voltage is back to normal, please restart the controller. If the voltage is back to normal after starting controller still does not work, please replace the controller and notify the manufacturer
E r r - 0 4	When stop overvoltage	Disconnect the controller power supply, check whether the input power supply voltage is too high (above 264 v). If the supply voltage is on the high side, after the voltage is back to normal, please restart the controller. If the voltage is back to normal after starting controller still does not work, please replace the controller and notify the manufacturer.
E r r - 0 5	The runtime overvoltage	
E r r - 0 6	electromagnet Circuit fault	Shut down the system power supply, check that the magnet wire is correct, whether there is loose and broken. If there is change in time. After restart the system, if still cannot work, please replace the controller and notify the manufacturer.
E r r - 0 7	Current detection Circuit fault	Shut down the system power supply, 30 seconds to see if turning on the power supply can work normally. Try again a few times, if the fault occur frequently, please replace the controller and notify the manufacturer.
E r r - 0 8	Motor blocked	Disconnect the controller power supply, check whether the motor power input plug fall off, looseness, breakage, whether there is foreign body coil on the nose. Rule out after restart the system still does not work, please replace the controller and notify the manufacturer.
E r r - 0 9	Braking circuit fault	Shut down the system power supply, check whether joint on white braking resistor power panel loose or fall off, insert the tight after restart the system. If it still doesn't work, please replace the controller and notify the manufacturer.
E r r - 1 0	HMI communication failures	Check the connection to the control panel and the controller whether fracture, fall off, loose, it returned to normal after restart the system. If it still doesn't work, please replace the controller and notify the manufacturer.
E r r - 1 1	The nose needle Signal failure	Check whether the nose synchronous signal device and the connection to the controller is loose, it returned to normal after restart the system. If it still doesn't work, please replace the controller and notify the manufacturer.
E r r - 1 2	Motor fault initial Angle measure	Please try again when the power is 2-3 times, if still at fault, please replace the controller and notify the manufacturer
E r r - 1 3	Motor HALL fault	Shut down the system power supply, check that the motor sensor connector is loose or fall off, it

		returned to normal after restart the system. If it still doesn't work, please replace the controller and notify the manufacturer.
E r r - 1 4	DSP block read and write EEPROM failure	
E r r - 1 5	Electrical overspeed protection	
E r r - 1 6	Motor reversal	
E r r - 1 7	HMI block read and write EEPROM failure	
E r r - 1 8	Motor overload	
E r r - 2 3	Motor locked-rotor sector errors	Disconnect the controller power supply, check whether the motor power input plug fall off, looseness, breakage, whether there is foreign body coil on the nose. Rule out after restart the system still does not work, please replace the controller and notify the manufacturer.



## 第4章 特殊功能操作说明



### 4.1 上停针位调整

1		<p>控制系统在恢复出厂后，可根据需要重新设置上针位！</p> <p>第一步：先按下  键不放，再按下  键，即进入监控模式，默认为024号监控参数，液晶屏显示当前角度，如为0°表明此位置为系统当前默认的上停针位置。</p>
2		<p>第二步：转动手轮，让挑线杆到上停针位置或希望调整到的合适位置，此时液晶屏显示调整后的上停针位，如124。</p>
3		<p>第三步：长按  待出现“----”后放开，等出现“8888”后保存成功。</p>





## Chapter 4 special function instructions

### 4.1 The needle on an adjustment



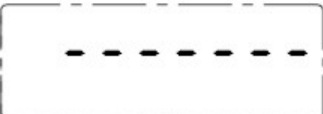

1		<p>Control system after the restore factory, can according to the need to reset the needle! First step: the first press the key  , press the key  again, namely</p>
---	--	---

		into monitor mode, the default value is no. 024 monitoring parameters of liquid crystal screen display the current point of view, such as 0 ° show that the location of the needle on the system of the current default location.
2		Step 2: turn the handwheel, let the take-up on the needle position or want to adjust to the appropriate location, the LCD shows the adjusted on the needle position, such as 124.
3		Step 3: long press to appear after the "-" let go, such as a "8888" after successfully saved.



#### 4.2 一键恢复机头厂家参数值



1		如果希望恢复机头厂家的出厂参数，可按照如下步骤：第一步：先按下  键不放，再按下  键，即进入监控模式，默认为024 号监控参数。
2		第二步：长按  键3 秒钟以上，开始一键恢复机头厂家参数，液晶屏显示横杠，表明正在恢复参数，此时控制器切勿断电或拔出操作面板插头。
3		待数码管显示8，表明机头厂家恢复参数完成





#### 4.3 自动测试

自动测试：同时按  键和  号键两次后，LCD 显示闪烁的 ，点踩踏板即可实现自动测试；同时按  键和  号键，退出自动测试。

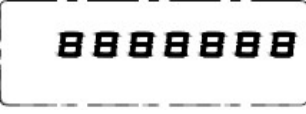
#### 4.2 A key to restore the nose manufacturer parameter values

1		If you want to restore the nose manufacturer factory parameters, can according to the following steps: first step: first press the button  , then press the key  , namely into monitor mode, the default value is no. 024 monitoring parameters.
---	---	--

2		Step 2: long press  more than 3 seconds, start a recovery head manufacturer parameters, LCD shows rung, that recovering parameters, the controller do not power or pull out plug operation panel.
3		For eight digital tube display, which indicates that the nose manufacturer parameters to complete recovery

4.3 Automatic test: at the same time according to the  and  keys after twice, LCD display flashing <sup>AUTO</sup>TEST, points pedal can realize automatic test; According to  and  keys at the same time, out of automatic test.



# 零件样本

(Parts Book)

# 1. 钮钳机构部件 BUTTON CLAMP MECHANISM COMPONENTS

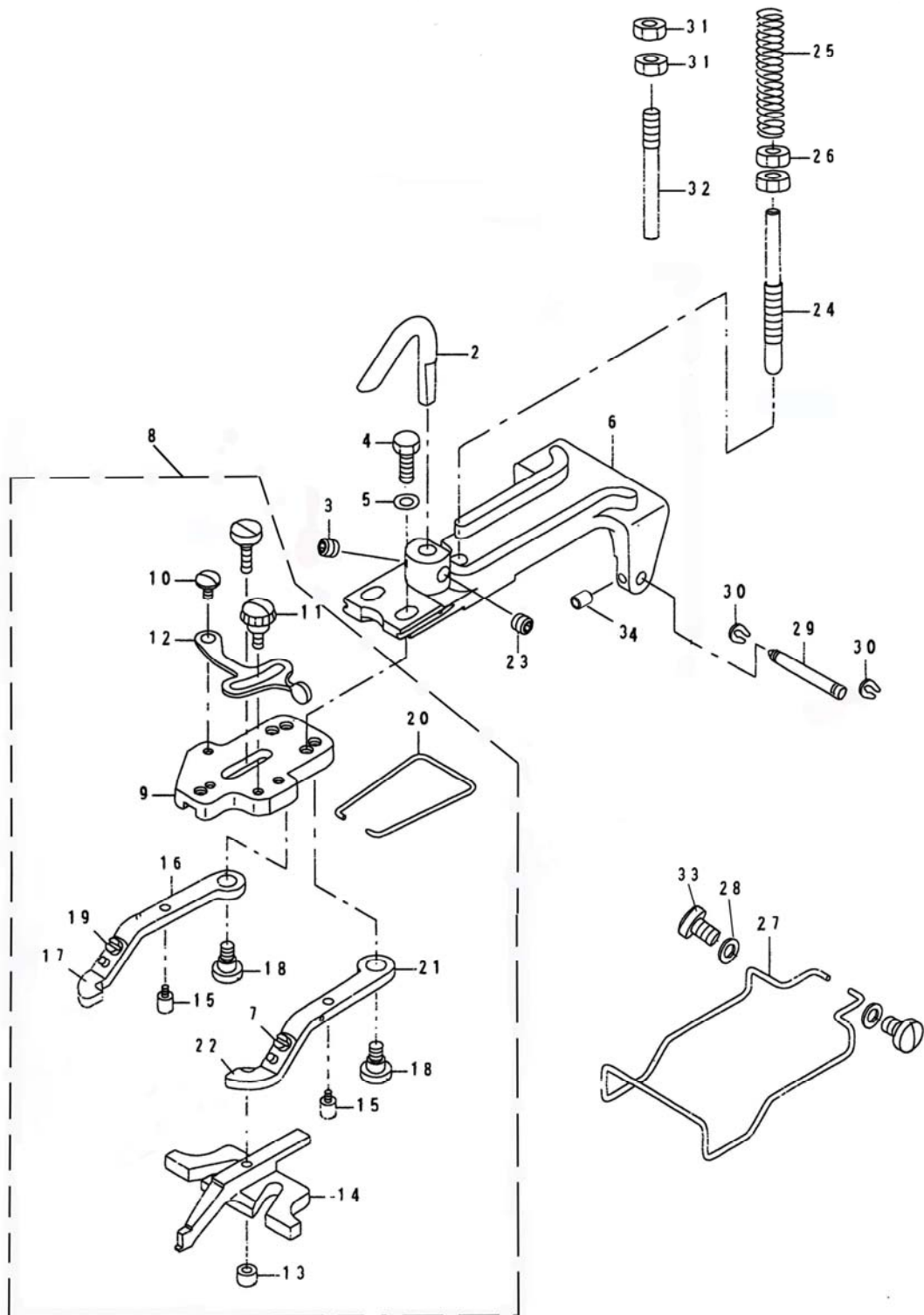

## 1、 钮钳机构部件/Button clamp mechanism components

序号	零件件号	名称	数量	DESCRIPTION
1	-----	抬压脚组件	1	PICK-UP DEVICE ASM.
2	40902001	钮针提升杆	1	BUTTON CLAMP LIFTING HOOK
3	402S14006	螺钉	1	SCREW 15/64-28 L=9
4	409S12001	螺钉	2	SCREW 3/16-32 L=13.5
5	40928001	垫圈	2	WASHER 5×10.5×1
6	300145	钮钳座	1	BUTTON CLAMP HOULDER
7	409S11002	螺钉	1	SCREW 9/64-40 L=3.5
8	4091200100	钮钳杆座组件	1	HINGE SCREW D=5.5 H=3
9	40912002	钮夹控制座	1	JAW LEVER HOLDER
10	409S20002	轴位螺钉	1	HINGE SCREW D=5.5 H=1.8
11	409S20003	钮夹螺钉	1	CLAMP SCREW A
12	40912003	钮夹止动杆	1	SNAP FASTENER CLAMP STOP LEVER
13	409S16001	螺母	1	NUT
14	40901003	钮夹滑块	1	BUTTON CLAMP SLIDE
15	409S20004	钮夹止动销	2	BUTTON CLAMP STOP PIN
16	40912005	左钮夹钳夹	1	BUTTON CLAMP LEVER JAW (LEFT)
17	40912006	钮扣左弹簧压板	1	BUTTON HOLDING SPRING LEFT
18	409S20005	轴位螺钉	2	HINGE SCREW D=6.35 H=3.9
19	409S11002	螺钉	1	SCREW 9/64-40 L=3.5
20	40927001	钮夹弹簧	1	BUTTON CLAMP SPRING
21	40912008	右钮夹钳夹	1	BUTTON CLAMP LEVER JAW RIGHT
22	40912009	钮夹右弹簧压板	1	BUTTON HOLDING SPRING RIGHT
23	402S14006	螺钉	1	SCREW 15/64-28 L=9
24	409S30002	钮钳调压杆	1	BUTTON CLAMP PRESSUER ADJUSTIN
25	40927002	钮夹压力弹簧	1	PRESSUER ADJUSTING SPRING
26	409S16003	螺母	2	NUT M6
27	40927003	手指保护架	1	FINGER GUARD
28	30128010	垫圈	2	WASHER
29	40902002	合叶销	1	HINGE PIN
30	H05002	卡簧	2	SNAP PIN
31	401S16002	螺母	2	NUT M6
32	409S30001	钮钳塞销	1	PICK-UP DEVICE STOPPER PIN
33	402S11007	螺钉	2	SCREW 11/64-40 L=3.5
34	413S14004	螺钉	2	SCREW M3

## 2. 机壳部件 ARM & MISCELLANEOUS COVERS COMPONENTS

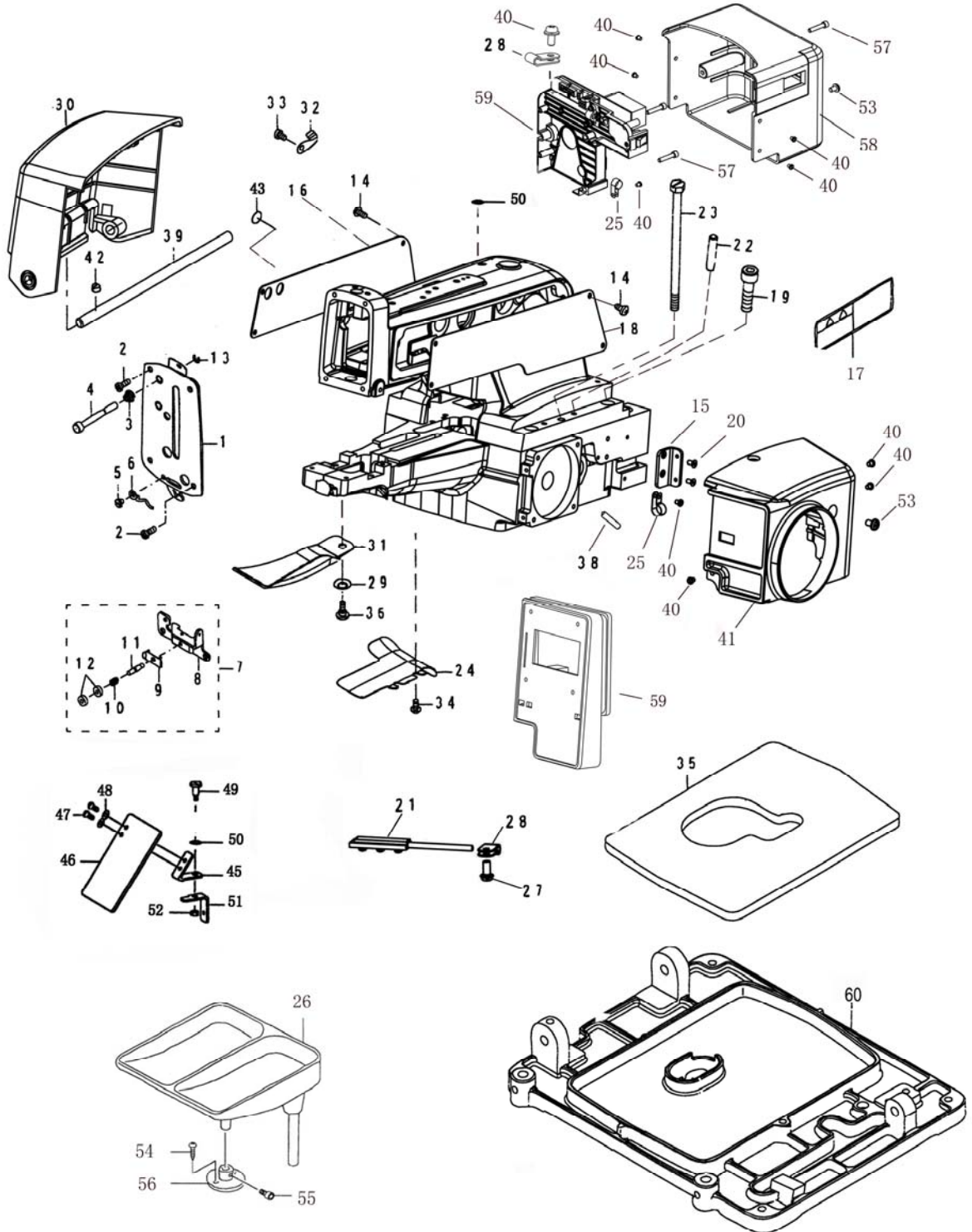

## 2、机壳部件/Arm & miscellaneous cover components

序号	零件件号	名称	数量	DESCRIPTION
1	4091206200	面板盖组件	1	FACE PLATE COMPL
2	406S11009	螺钉	4	SCREW
3	40927004	第三夹线弹簧	1	TENSION SPRING
4	40902003	夹线螺栓	1	NIPPER RELEASING STOP
5	409S11004	螺钉	1	SCREW
6	40913002	第四线导向装置	1	THREAD GUIDE NO. 4
7	4091301400	3号线张力器组件	1	THREAD TENSION NO. 3 ASM.
8	40913015	3号线张力调节座	1	TENSION ADJUSTING BASE NO. 3
9	40913016	线张力盘	1	THREAD PRESSER PLATE
10	40927020	弹簧	1	TENSION SPRING B
11	409S30017	线张力器螺栓	1	THREAD TENSION STUD
12	409S16026	张力调节螺母	2	THREAD TENSION NUT
13	H05002	GB/T896-1986挡圈3	1	E-RING 3. 2
14	406S11009	螺钉	8	SCREW
15	40912203	罩壳安装座	1	RUBBER PLUG
16	301805	左盖板	1	SIDE COVER RIGHT
17	40937008	安全标签	1	SAFETY LABEL
18	301807	右盖板	1	SIDE COVER LEFT
19	S05024	拼装螺钉	4	SCREW M8 L=30
20	409S11009	螺钉	2	SCREW
21	40930008	LED灯 (TD-5)	1	LED LAMP
22	P02002	GB/T117-1986销6×32	2	GUIDE PIN
23	409S30018	连接螺栓	1	SET SCREW
24	40912080	防油底板	1	BED OIL SHELD
25	41711014	电线夹	3	WIRE CLIP
26	4091100100	钮扣盘	1	BUTTON TRAY ASM
27	417S30025	螺栓M4X6	2	SCREW
28	41711014	电线夹	3	WIRE CLIP
29	40228001	弹性垫圈	1	SPRING WASHER 6. 5×14. 0×17
30	40911007	左侧盖	1	SIDE COVER LEFT
31	40912081	底座活动盖	1	LOOPER COVER
32	40912067	侧盖弹簧片	2	SIDE COVER SPRING
33	409S11006	螺钉	2	SCREW M4 L=6
34	409S11007	螺钉	2	SCREW
35	40923013	滴油毡	1	OIL DRIP FELT
36	409S20006	螺钉	1	SHOULDER SCREW D=6 H=2. 7
37	61910003	扎带 (小)	4	RIBBON
38	40926002	凸轮指示销	2	CAM INDECATING PIN
39	40902019	左侧盖轴	1	SIDE COVER HINGE SHAFT LEFT
40	417S30009	螺钉	10	SCREW
41	40911011	电机罩壳	1	SIDE COVER
42	402S14006	螺钉	1	SCREW M6 L=6
43	40122017	橡皮塞	1	RUBBER PLUG
45	40112008	安全板支架	2	SAFETY PLATE
46	40911006	安全板	2	SAFETY PLATE
47	409S11008	螺钉	2	SCREW M4 L=6
48	40928002	垫圈	1	SPRING WASHER 5. 0×110
49	402S20032	轴位螺钉	1	HINGE SCREW D=6 H=2. 5
50	40128001	波形垫圈	2	SPRING
51	40912020	安全板安装座	1	SAFETY PLATE INSTALLING BASE
52	401S16004	螺母	1	NUT SM15/64-28
53	421S10013	螺钉M5×8	2	SCREW
54	421s30002	木螺钉	3	WOOD SCREW
55	S10009	螺钉M6×12	1	SCREW
56	300941	纽扣盘固定座	1	BUTTON TRAY BASE
57	S05083	螺钉M5×30	3	SCREW
58	40911012	电控罩壳	1	MOTOR COVER
59	40933002	电控	1	CONTROL BOX
60	40901022	油盘	1	OIL RESERVOIR

### 3. 下轴部件 LOOPER SHAFT MECHANISM COMPONENTS

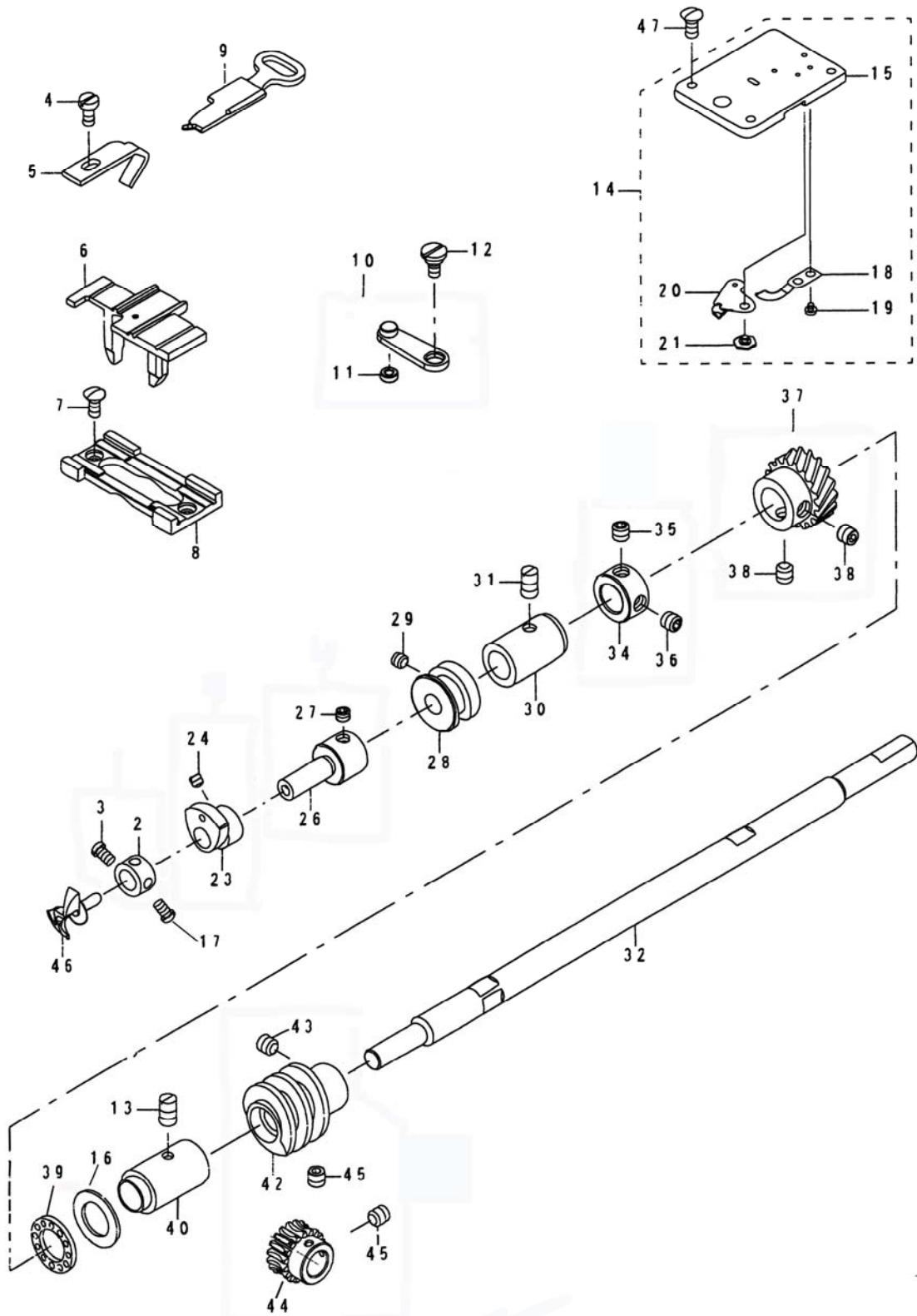

### 3、下轴部件/Looper shaft mechanism components

序号	零件件号	名称	数量	DESCRIPTION
1	-----	挡圈组件	1	THRUST COLLAR .ASM
2	40908002	挡圈	1	THRUST COLLAR D=7.94 W=7
3	409S11012	螺钉	1	SCREW 9/64-40 L=6.1
4	409S11010	螺钉	1	SCREW
5	40912021	导向线杆（打捆针导向器）	1	NEEDLE GUARD
6	40909001	插入导向滑板	1	POSITONGNING FINGER YOKE SLIDE
7	409S17001	螺钉	2	SCREW M4 L=9
8	40909002	导向卡箍（压铁插孔）	1	YOKE SLIDE INSERT
9	40912022	滑块（压铁片）	1	YOKE SLIDE
10	4090500100	环形定位杆	1	ASSY LOOP POSITIONING FINGER L
11	40903003	滚珠	1	LOOP POSITIONNING FINGER CAM RO
12	409S20008	轴位螺钉	1	HINGE SCREW D=6.35 H=2.4
13	401S14001	螺钉	1	SCREW
14	-----	针板组件	1	THROAT PLATE SET
15	40901005	针板	1	THROAT PLATE ASM.
16	40928004	轴承垫圈	1	BEARING WASHER
17	409S11031	螺钉	1	SCREW
18	40919003	定刀	1	COUNTER KNIFE
19	409S11011	螺钉	2	SCREW1/8-44 L=3.0
20	4091900100	动刀	1	MOVING KNIFE ASM.
21	409S20009	螺钉	1	HINGE SCREW D=6 H=0.85
22	-----	分线三角凸轮	1	ASSY LOOP POSITIONING FINGER C
23	40910001	后凸轮	1	LOOP POSITIONING FINGER CAM
24	409S14002	螺钉	2	SCREW 11/64-40 L=3.5
25	-----	连接轴组件	1	ASSY CAM AND LOOPER SLEEVE
26	40902006	连接轴	1	CAM AND LOOPER SLEEVE
27	409S15004	螺钉	2	SCREW 15/64-28 L=4.0
28	40910002	后凸轮	1	LOOP POSITIONONGNING FINGER CAM RE
29	409S14002	螺钉	2	SCREW 11/64-40 L=2.8
30	40903004	下轴前套	1	LOOPER SHAFT BUSHING FRONT
31	401S14001	螺钉	1	SCREW
32	40902026	下轴	1	LOOPER SHAFT
33	-----	挡圈组件	1	THRUST COLLAR ASM, D=11.11, W=1
34	40908001	挡圈	1	THRUST COLLAR ASM, D=11.11, W=10
35	409S14003	螺钉	1	SCREW 1/4-40 L=5
36	409S14003	螺钉	1	SCREW 1/4-40 L=5
37	40925002	勾线轴齿轮	1	LOOPER SHAFT DRIVER GEAR ASM.
38	409S14001	螺钉	2	SCREW 1/4-40 L=6
39	40924001	端面轴承	1	THRUST BALL BEARING
40	40903005	下轴后套	1	LOOPER SHAFT BUSHING REAR
41	-----	蜗轮蜗杆组件	1	WORM WHEEL ASM.
42	40925011	蜗杆	1	WORM
43	409S14003	螺钉	2	SCREW 1/4-40 L=7
44	40925001	凸轮轴从动齿轮	1	CAM SHAFT ASM.
45	409S14003	螺钉	2	SCREW 1/4-40 L=6
46	40917001	钩圈	1	LOOPER
47	409S11009	螺钉	3	SCREW M4 L=9

#### 4. 绕线和过线部件 NIPPER & THREAD TENSION PARTS COMPONENTS

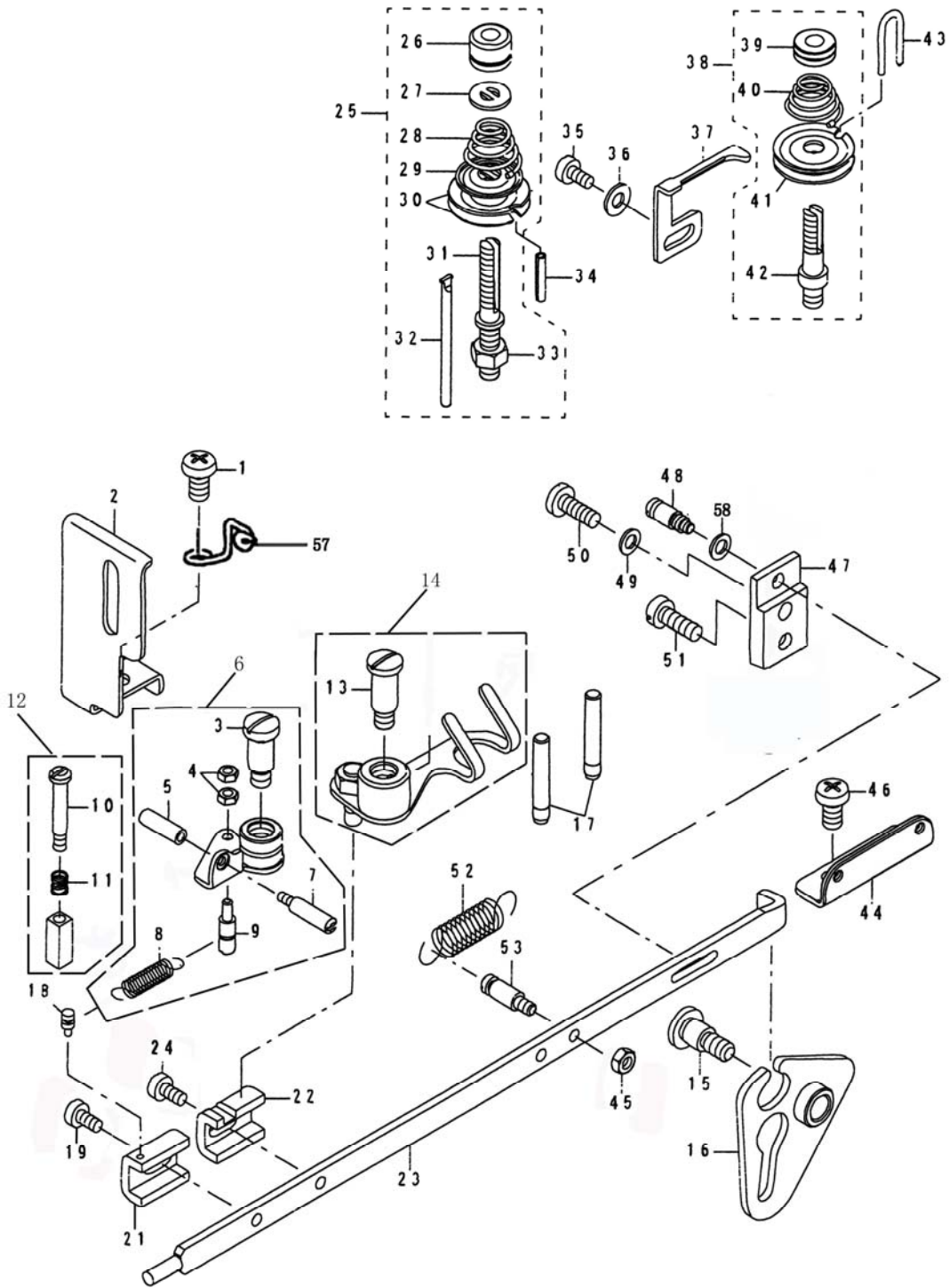



#### 4、绕线和过线部件/Nipper & tension parts components

序号	零件件号	名称	数量	DESCRIPTION
1	409S11013	螺钉	1	SCREW M6 L=12
2	40912024	针杆防护罩	1	NEEDLE BAR GUARD
3	409S20013	轴位螺钉	1	SHOULDER SCREW
4	409S16005	螺母	2	NUT
5	409S16006	松线螺母	1	NUT
6	4091202500	导线装置	1	NIPPER COMPL
7	409S20011	松线销	1	LOOPER SHAFT BUSHING REAR
8	40927007	夹线杆拉伸弹簧	1	NIPPER BAR BLOCK SPRING
9	409S30004	弹簧销	1	NIPPER BAR BLOCK SPRING SCREW
10	409S20012	螺钉	1	HINGE SCREW D=4 H=20
11	40927008	夹线座弹簧	1	HIPPER SLIDE BLOCK SPRING
12	40909003	夹线座	1	NIPPER BLOCK
13	409S20013	螺钉	1	SHOULDER SCREW D=7.94 H=15
14	4091300400	引线杆组件	1	THREAD PULL OFF LEVER ASM.
15	409S20014	驱动杆轴位螺钉	1	SHOULDER SCREW D=7.94 H=8
16	4091202700	夹线杆驱动杆组件	1	NIPPER BAR ACTUATING LEVER ASM.
17	40926006	导线杆	2	THREAD GUIDE PIN
18	40926007	夹线杆底座弹簧销	1	NIPPER BAR BLOCK SPRING PIN
19	409S11014	螺钉	1	SCREW
21	40912029	夹线杆驱动块	1	NIPPER BAR BLOCK
22	40912030	拨线杆驱动块	1	TENSION LEVER ROCKING PIECE
23	40912031	夹线杆	1	NIPPER BAR
24	409S11014	螺钉	1	SCREW
25	4091300600	2号夹线杆组件	1	TENSION POST ASM NO. 2
26	409S16007	调节螺母	1	TENSION NUT
27	40912032	夹线器防松盘	1	ROTATION STOPPER
28	40927009	夹线器弹簧	1	THREAD TENSION SPRING
29	40912033	松线板	1	THREAD TENSION DISK PRESSER
30	40913007	夹线板	2	THREAD TENSION NO. 1
31	409S30006	第二夹线杆	1	TENSION POST NO. 2
32	409S16008	夹线板松线杆	1	TENSION RELEASE PIN
33	40926008	螺母	1	NUT M6
34	P03009	弹性圆柱销	1	SPRING PIN 3×16
35	409S11014	螺钉	1	SCREW
36	40928004	垫圈	1	WASHER
37	40912034	释压杆	1	THREAD TENSION RELEASING LEVER
38	4091300800	1号夹线器组件	1	ASSY HTHREAD RENSIION NO. 1
39	409S16009	调节螺母	1	THREAD TENSION NUT
40	40927010	夹线器弹簧	1	FIRST THREAD TENSION SPRING
41	40913007	夹线板	2	THREAD RENSIION DISK NO. 1
42	409S30007	第一夹线杆	1	THREAD RENSIION POST NO. 2
43	40913009	导线钩	1	THREAD GUIDE
44	40913010	二眼线板	1	THREAD GUIDE NO. 1
45	409S16024	螺母	1	NUT M4
46	409S11013	螺钉	1	SCREW M5 L=14
47	40912100	夹线杆滑块	1	NIPPER BAR BEARING BLOCK
48	409S30008	调节螺钉	1	ADJUSTING SCREW
49	40928005	垫圈	1	WASHER 5.5×10×0.8
50	409S11015	螺钉	1	SCREW M6 L=12
51	409S11016	螺钉	1	SCREW
52	40927011	2号钳杆弹簧	1	THREAD TENSION SPRING
53	409S30009	夹线杆拉伸弹簧销	1	NIPPER BAR SPRING SCREW
57	40913012	2号导线钩	1	THREAD GUIDE
58	40928005	垫圈	1	WASHER 5×10.5×1

## 5. 送料盘部件 FEED PLATE COMPONENTS

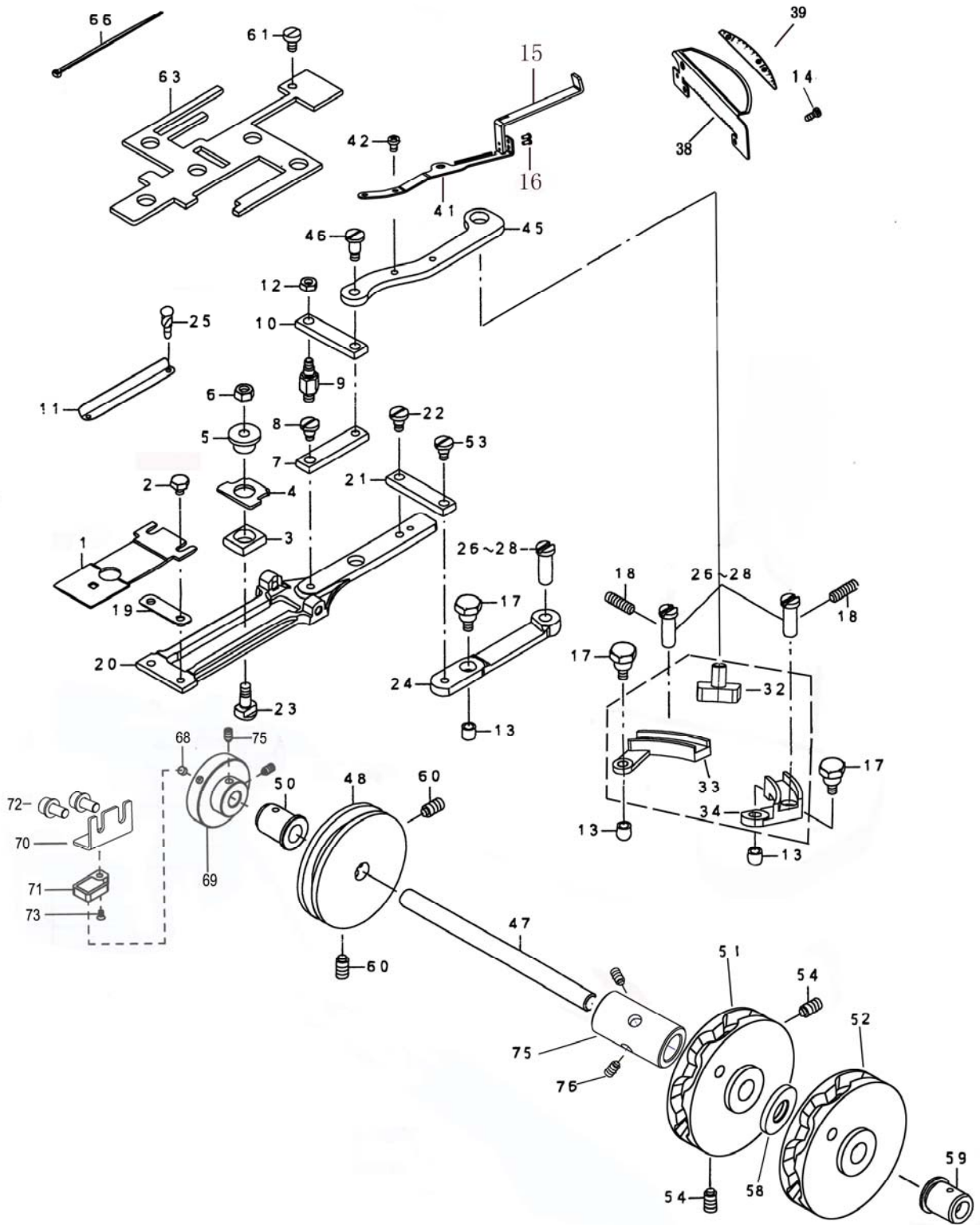

## 5、送料盘部件/Feed plate components

序号	零件件号	名称	数量	DESCRIPTION
1	40915001	送料板	1	FEED PLATE SMALL BUTTON
2	409S12003	螺钉	2	SCREW 3/16-28 L=6
3	40909004	交叉送料滑块	1	INDICATOR PIN BEARING BLOCK
4	40912036	交叉送料指示板	1	CROSSWISE FEED INDICATOR
5	40903010	交叉送料轴承座	1	CROSSWISE FEED INDICATOR PIN
6	409S16012	螺母	1	NUT M=6
7	400110	滑板连接杆	1	SLIDE PLATE CONNECTING LINK
8	409S20015	轴位螺钉	1	HING SCREW D=6.35 H=4.8
9	409S30010	双头螺栓	1	STUD
10	400111	连接杆	1	INTERMEDI CONNECTING LINK
11	40937001	交叉送料刻度盘	1	CROSSWISE FEED GRADVATED PLATE
12	409S16013	螺母	1	NUT M5
13	40903012	送料凸轮滚子	3	CAM ROLL
14	409S11003	螺钉	2	SCREW
15	40912208	手柄	1	HANDLE AND INDICATOR SPRING
16	421S10005	螺钉M3×6	2	SCREW
17	409S30019	送料凸轮滚子螺栓	3	CAM ROLL SCREW STUD
18	401S14001	螺钉	3	SCREW M6×12
19	40912040	连接杆	1	SPACER PLATE
20	40901006	送料底板	1	FEED PLATE
21	400110	滑板连接杆	1	INTERMEDI CONNECTING LINK
22	409S20015	轴位螺钉	1	HING SCREW D=6.35 H=4.8
23	409S30012	交叉送料轴位螺钉	1	HING SCREW FOR CROSSWISE FEED
24	40904003	交叉送料调节杠杆	1	CROSSWISE FEED LEVER
25	R01002	铆钉	5	RIVET
26	40926010	杆销	1	FEED STUD A
27	40926010	杆销	1	FEED STUD B
28	40926010	杆销	1	FEED STUD C
32	401846	送料调杆滑块	1	LENGTHWISE FEED LEVER SLIDE
33	401847	送料调节杠杆左	1	FEED LEVER L
34	401848	送料调节杠杆右	1	FEED LEVER R
38	40912205	送料调节盘底座	1	PLATE BASE
39	40937010	刻度盘贴膜	1	GRADUATE PLATE
41	40912206	调节手柄	1	HANDLE AND INDICATOR SPRING
42	403S11027	螺钉	2	SCREW M4 L=6
45	40904004	调节手柄连接杆	1	INDICATOR SPRING CONNECTING LI
46	409S20016	轴位螺钉	2	SHOULDER SCREW D=6.35 H=9.7
47	40902022	凸轮轴	1	CAM SHAFT
48	40910019	十字纵向送料盘	1	LENGRHWAISE FEED CAM(X)
50	40903040	凸轮轴右套	1	CAM SHAFT BUSHING LEFT
51	40910006	交叉送料凸轮	1	FEED CAM ASM.
52	40910004	纵向送料凸轮（一字）	1	LENGRHWAISE FEED CAM(-)
53	409S20035	轴位螺钉	1	SHOULDER SCREW D=6.35 H=4.8
54	409S14005	螺钉	2	SCREW 9/32-28 L=13.5
58	40912087	垫圈	1	WASHER
59	40903039	凸轮轴右轴套	1	CAM SHAFT BUSHING RIGHT
60	409S14005	螺钉	5	SCREW 9/32-28 L=13.5
61	409S11005	螺钉	1	SCREW M5 L=8
63	40923015	油毡	1	FEED SHOULDER SCREW FELT
66	61910003	扎带（小）	3	CABLE BAND
68	40930007	磁铁	1	MAGNET
69	40930003	信号轮	1	SINGLE WHEEL
70	40912108	传感器安装座	1	HALL SWITCH HOLDER
71	-----	霍尔开关	1	HALL SWITCH
72	417S30033	螺栓（带垫圈）M4×8	2	SCREE
73	407S17003	十字沉头螺钉M3×4	1	SCREE
75	40903043	定位套	1	POSITONING SLEEVE
76	409S14003	螺钉	2	SCREW 1/4-40 L=5

## 6. 按钮提升机构部件 BUTTON CLAMP LIFTER COMPONENT

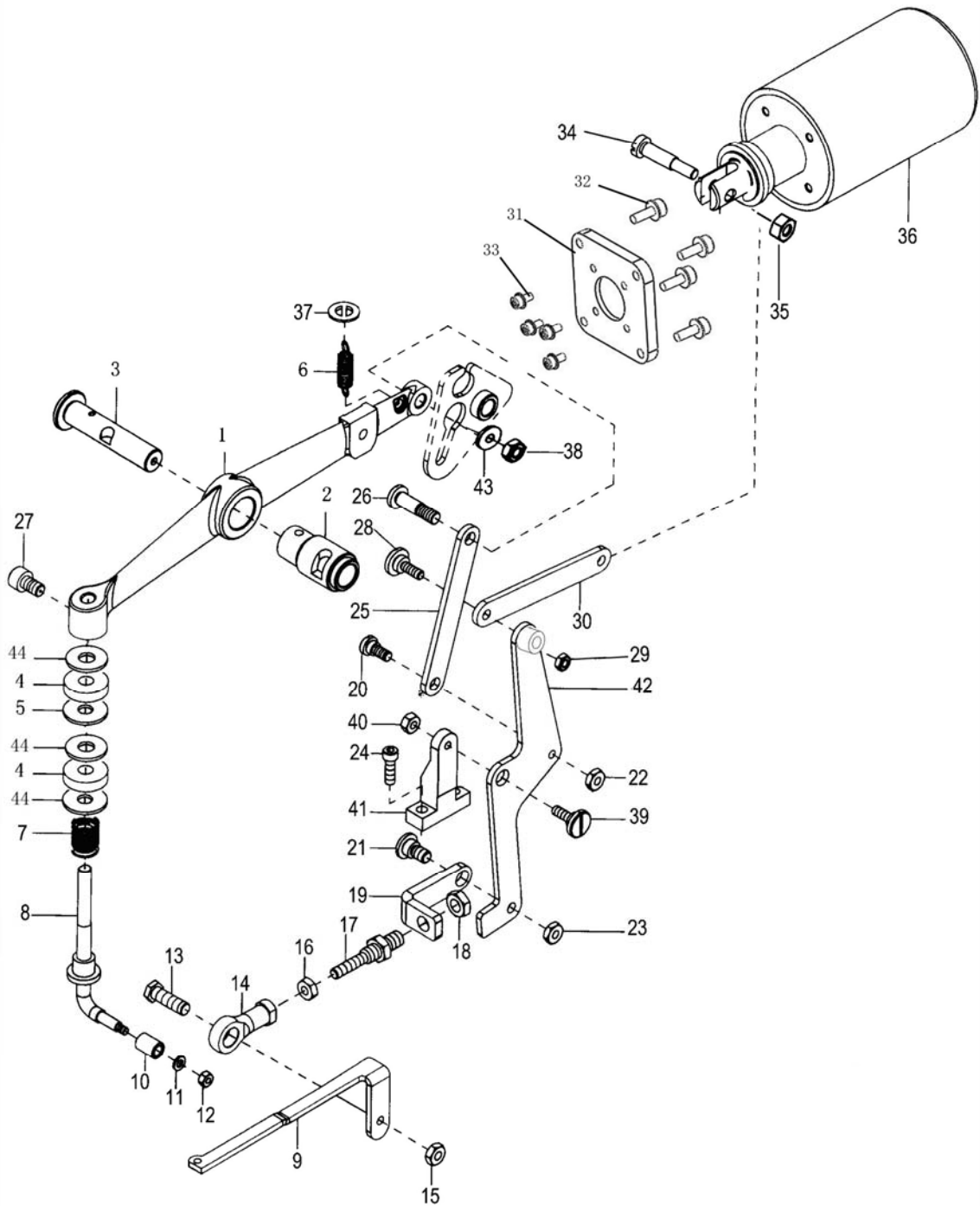

## 6、钮钳提升部件/Button clamp lifter components

序号	零件件号	名称	数量	DESCRIPTION
1	40901033	抬压杠杆	1	LIFTING LEVER
2	40903016	轴套	1	BUSHING
3	40902009	针棒杠杆轴	1	NDDELE BAR LEVER
4	40922001	橡胶垫	2	CUSHION
5	40928014	垫圈	2	WASHER 8.5×18.0×1.2
6	40927012	弹簧	1	SPRING
7	40927013	弹簧	1	SPRING
8	4090201100	钮钳提升杆钩	1	BUTTON CLAMP LIFTING ROD A
9	40912042	切线连杆	1	CONNECTING LINK FRONT
10	40903020	钮钳提升杆滚筒	1	L TYPE LIFTING BAR ROLLER
11	40928021	垫圈	1	WASHER
12	409S16014	螺母	1	NUT 9/64-40
13	L01002	螺钉	1	JOINT STUD
14	4030500500	切线连接球体	1	FEED ADJUSTING JOINT
15	N01004	螺母	2	NUT M5
16	N01004	螺母	2	NUT M5
17	409S30013	连接螺钉	1	CONNECTING SCREW
18	409S16015	螺母	2	NUT M8 TYPE1
19	40912089	后切线连接杆	1	CONNECTING LINK REAR
20	409S20036	轴位螺钉	1	HINGE SCREW D=6.35 H=3.2
21	409S20037	轴位螺钉	1	HINGE SCREW D=7.94 H=4
22	409S16013	螺母	1	NUT 3/16-32
23	401S16002	螺母	1	NUT 15/64-28
24	40912044	切线杠杆	1	THREAD TRIMMING LEVER
24	409S11021	螺钉	2	SCREW M5 L=14
25	40912090	切线连杆	1	THREAD TRIMMING LINK
26	409S20023	轴位螺钉	1	HINGE SCREW D=6.35 H
27	S05023	螺钉	1	SCREW M6 L=10
28	409S20038	轴位螺钉	1	HINGE SCREW D=6.35 H
29	401S16002	螺母	1	NUT 3/16-32
30	40912091	电磁铁连杆	1	MAGNET CONNECT POLE
31	40912092	电磁铁安装板	1	MAGNET HOLEDER
32	417S30306	带弹垫螺钉M5X15	4	SCREW M5 L=15
33	417S30033	螺栓（带垫圈）M4×8	4	SCREW M4 L=8
34	409S20039	电磁铁销钉	1	PIN
35	413S16003	螺母M4	2	NUT M4
36	40930005	电磁铁	1	ELECTROMAGNET
37	40912032	垫圈	1	WASHER
38	401S16002	螺母	1	NUT
39	409S20040	轴位螺钉	1	SHOULDER SCREW D=7.94 H=3.1
40	401S16002	螺母	1	NUT M5
41	40901036	切线杠杆座	1	THREAD TRIMMING LEVER BASE
42	4091210000	连杆	1	CRANK ROD
43	40128034	垫圈	1	WASHER
44	40928022	垫圈	2	WASHER

## 7.推針滑輪軸部件/Needle driving pulley shaft components

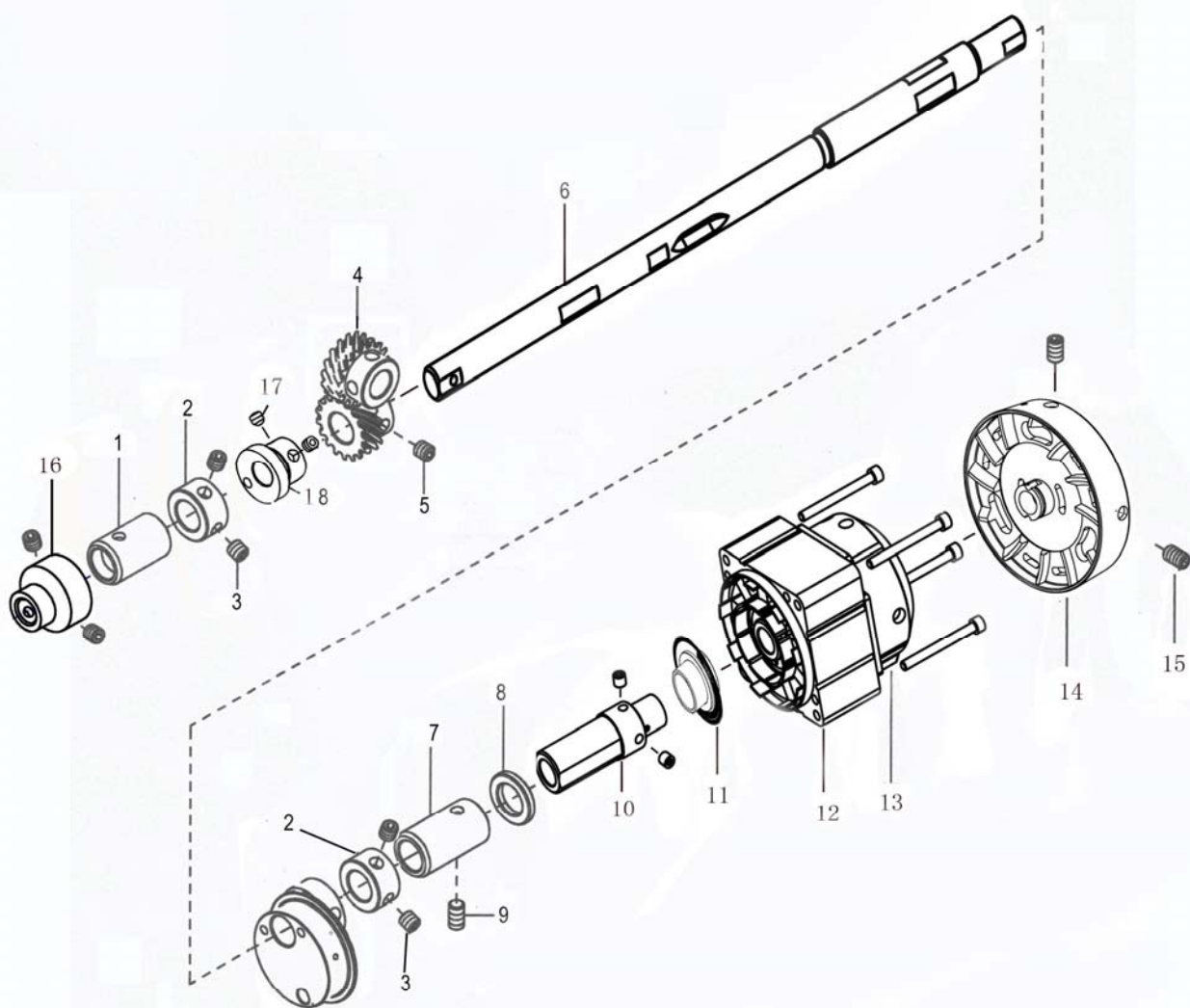

## 7、推针滑轮轴部件/Needle driving pulley shaft components

序号	零件件号	名称	数量	DESCRIPTION
1	40903034	滑轮轴左套	1	PULLEY SHAFT BUSHING LEFT
2	40603020	挡圈	2	THRUST COLLAR
3	403S14004	螺钉	2	SCREW M6
4	40925004	滑轮轴齿轮	1	DRIVING GEAR(A) ASM.
5	409S14001	螺钉	2	SCREW 1/4-40 L=6
6	40902051	滑轮轴	1	NEEDLE DRIVING PULLEY SHAFT
7	40903024	滑轮轴右套	1	PULLEY SHAFT BUSHING RIGHT
9	401S14001	螺钉	1	SCREW
10	1383300400	电机转子组件	1	Rotor components
11	1383300900	电机光栅组件	1	Gratings components
12	13833003	电机定子总成	1	Stator components
13	1383300700	电机罩壳组件	1	Motor cover components
14	302443	手轮	1	PULLEY
15	403S14004	螺钉M6	2	SCREW M6
16	40910021	平衡凸轮	1	BALANCE CAM
17	409S14003	螺钉	2	SCREW
18	40910020	偏心轮	1	ECCENTRIC CAM

## 8. 针杆驱动部件 NEEDLE BAR DRIVING MECHANISM COMPONENTS

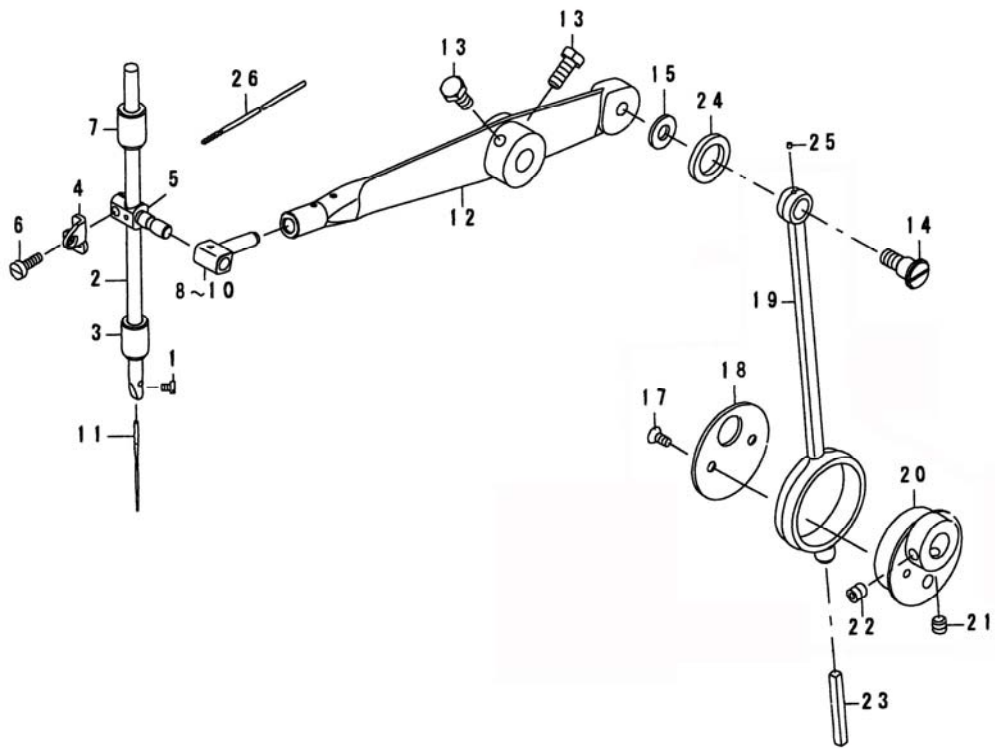



## 8、针杆驱动机构部件/Needle bar driving mechanism components

序号	零件件号	名称	数量	DESCRIPTION
1	101S11006	螺钉	1	SCREW 1/8-44 L=4.5
2	40902027	针杆	1	NEEDLE ROD
3	40903026	针杆下套	1	NEEDLE BAR BUSHING LOWER
4	40913013	导线	1	NEEDLE BAR BALACE
5	40909017	针棒轴衬座	1	NEEDLE BAR CLAMP
6	409S11024	螺钉	1	SCREW M4 L=12
7	40903035	针杆上套	1	NEEDLE BAR BUSHING UPPER
8	40909016	针杆轴承座	1	NEEDLE BAR SLIDE BLOCK A
9	-----	针杆轴承座	1	NEEDLE BAR SLIDE BLOCK B
10	-----	针杆轴承座	1	NEEDLE BAR SLIDE BLOCK C
11	41017001	机针	1	NEEDLE TQ×1 #16
12	40905007	针杆杠杆	1	NEEDLE BAR DRIVING LEVER
13	L02008	螺钉	2	SCREW M6 L=14
14	409S20025	轴位螺钉	1	SHOULDER SCREW D=9.53 H=8
15	40928013	垫圈	1	WASHER
16	-----	连杆组件	1	CRANK ROD ASM.
17	409S11009	螺钉	2	SCREW 11/64-40 L=8.5
18	40912046	盖板	1	THRUST HOLDER
19	40905009	连杆	1	CRANK ROD
20	40910009	偏心轮	1	ECCENTRIC CAM
21	40910009	螺钉	1	SCREW 1/4-40 L=6
22	409S14001	螺钉	1	SCREW 1/4-40 L=8.5
23	40923008	油线	1	OIL WICK
24	40923014	油毡	1	OIL RETAINNING FELT
25	40923008	油线	0.01	OIL WICK
26	40923008	油线	0.1	OIL WICK

# 九、附件组件/ Accessory parts components

## 11. 附件组件 ACCESSORY PARTS COMPONENTS

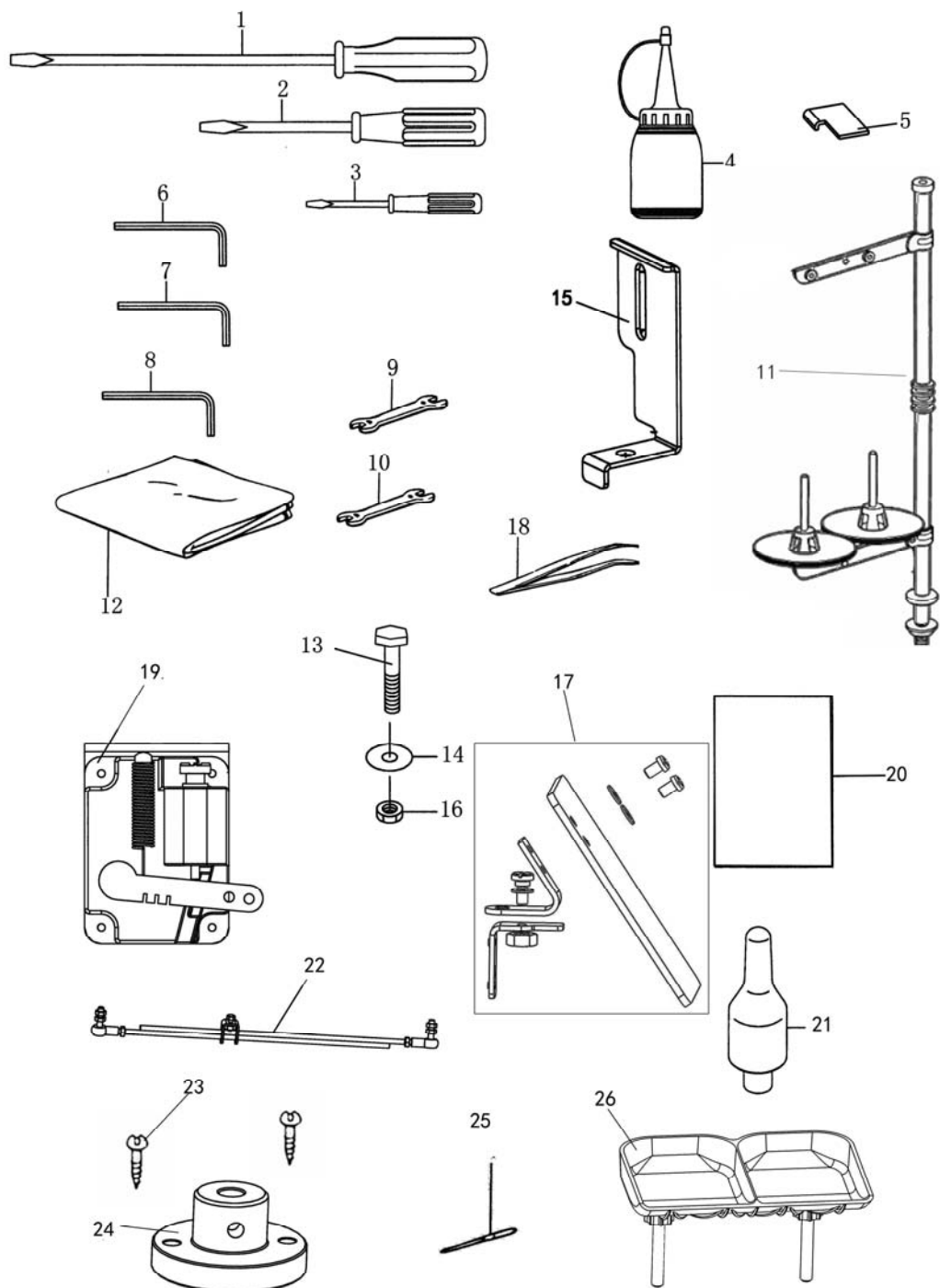

## 九、附件组件/ Accessory parts components

序号	零件件号	名称	数量	DESCRIPTION
1	10131002	螺丝刀 (大)	1	SCREW DRIVER LARGE
2	10131003	螺丝刀 (中)	1	SCREW DRIVER MIDDLE
3	10131004	螺丝刀 (小)	1	SCREW DRIVER SMALL
4	20131038	小油壶 (尖嘴)	1	OILER
5	40931019	定位尺	1	GAUGE
6	30131010	内六角扳手 (3mm)	1	INNER WERNCH 3mm
7	30131012	内六角扳手 (4mm)	1	INNER WERNCH 4mm
8	20131047	内六角扳手 (5mm)	1	INNER WERNCH 5mm
9	30131006	扳手 (8mm~10mm)	1	Wrench 8mm~10mm
10	40931025	扳手 (9mm~11mm)	1	Wrench 9mm~11mm
11	40931031	单盘线架	1	COTTON STAND ASSY 2DTHF
12	40131017	机头罩	1	MACHINE COVER
13	40931009	M6×70 螺钉	4	SCREW M6 L=70
14	-----	橡胶垫	4	WASHER 6.2×13×1
15	40912024	针杆护罩	1	NDDELE BAR GUARD
16	N01007	螺母 M6	4	NUT M6
	409s11008	螺钉	2	SCREW
	402s20032	轴位螺钉	1	SHOULDER SCREW
	s05035	M5×25 螺钉	3	SCREW
	40912020	安全板安装座	1	THE MOUNTING SEAT
17	40928002	垫圈	2	WASHER
	40112008	安全板安装板	1	SAFETY BOARD MOUNTING PLATE
	40128029	弹簧垫圈 Ø8	4	SPRING WASHER
	401s16003	螺帽	1	NUT
	40911006	安全板	1	SAFETY BOARD
18	20131051	镊子	1	TWEEZERS
19	-----	脚踏	1	Pedals
20	40931028	说明书	1	INSTRUCTION MANUAL & PARTS LIST
21	40931021	支撑杆	1	SUPPORT
22	-----	脚踏连杆	1	Pedals connecting rod
23	403S30020	木螺钉	6	Wood screw
24	300841	纽扣盘底座	1	Button plate of the base
25	41017004	TQ*7 16#机针	3	NEEDLE TQ×7#16-12
26	4091100100	纽扣盘组件	1	Button plate