GLOBAL

WF 905

INDUSTRIAL SEWING MACHINE

**Cylindrical Bed
Extra Heavy Duty
Compound-Feed**

INSTRUCTION MANUAL

CATALOG

A large, light gray watermark logo is centered on the page. It consists of a semi-circular arc at the top and bottom, with the letters 'CSMP' in a bold, stylized font in the middle. The 'C' is a simple block letter, 'S' has a curved bottom, 'M' has a central vertical bar, and 'P' has a small square at the bottom right.

INSTRUCTION MANUAL

≡CONTENT≡

1. PRECAUTIONS FOR USER	1
2. SPECIFICATION	2
3. PREPARATION FOR OPERATION	2
(1) Cleaning the machine	2
(2) Examination	2
(3) Lubrication	2
(4) Testing	3
4. HOW TO ATTACH A NEEDLE	3
5. WINDING OF BOBBIN THREAD	4
6. ADJUSTMENT OF THE BOBBIN WINDER	4
7. THREADING	5
8. REMOVING AND INSERTING THE BOBBIN	5
9. ADJUSTING THE THREAD TENSION	6
10. ADJUSTMENT OF PRESSER PRESSURE	6
11. ADJUSTMENT OF WALKING FOOT AND PRESSER FOOT	7
12. ADJUSTMNET OF STITCH LENGTH AND FORWARD/BACKWARD SEWING	7
13. FEED DOG HEIGHT	8
14. ADJUSTING THE HEIGHT OF THE NEEDLE BAR	8

1、 PRECAUTIONS FOR USER

(1) Precautions for Safety

- ① When turning the power on, keep your hands and fingers away from the area around/under the needle and the area around the pulley.
- ② The power must be turned off when the machine is not used, or when the operator leaves his/her seat.
- ③ The power must be turned off before installing or removing the “V” belt, adjusting the machine, or when replacing.
- ④ Avoid placing fingers, hairs, bars etc. near the pulley, the “V” belt and the motor when the machine is in operation.
- ⑤ Do not put fingers under/around the needle or the pulley when the machine is in operation.

(2) Precautions before Operation

- ① Never operate the machine before it is lubricated fully.
- ② When a new sewing machine is first turned on, verify the rotational direction of the pulley with the power on.
(The pulley should rotate counterclockwise when viewed from the pulley)
- ③ Verify the voltage and phase (single or three) with those given on the motor nameplate.

(3) Precautions for Operating Conditions

- ① Avoid using the machine at abnormally high temperature (35°C or higher) or low temperature (5°C or lower) .
- ② Avoid using the machine in dusty conditions.
- ③ Avoid using the machine in areas where there are too much electrical noise which resulted from the high-frequency weld and others.

2、 SPECIFICATION

Max. sewing speed (r.p.m)	800 r.p.m	
Needle No.	DY×3 26#	
Needle bar stroke (mm)	56	
Thread take-up lever stroke (mm)	96	
Stitch length (mm)	0-11	
Presser-foot stroke	By hand (mm)	13
	By knee (mm)	20

3、 PREPARATION FOR OPERATION

(1) Cleaning the machine

Before leaving the factory, the machine parts are coated with rust-preventive grease, which may be hardened and contaminated by dust during storage and shipment. This grease must be removed with gasoline.

(2) Examination

Though every machine is confirmed by strict inspection and test before leaving the factory, the machine parts may be loose or deformed after long distance transportation with jolt. A thorough examination must be performed after cleaning the machine. Turn the pulley to see if there is running obstruction, parts collision, uneven resistance or abnormal noise. If these exist, adjustment must be made accordingly before run-in operation.

(3) Lubrication (Fig.1)

When a new sewing machine is used for the first time, or sewing machine left out of use for considerably long time is used again, replenish a suitable amount of oil to the portions indicated by arrow in below figure.

CAUTION: Please use white spindle oil.

Always keep the presser lifted before attempting a dry run.

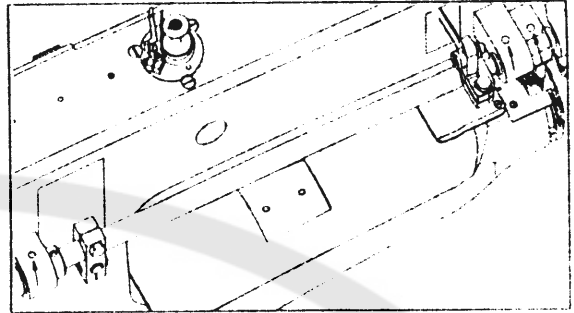
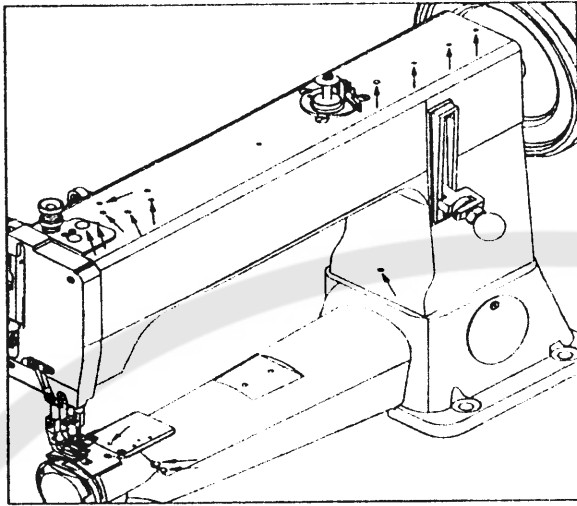

Fig.1

(4) Testing

In order to get the best working situation, run the sewing machine in a low speed for about 1 month after lubricated fully. Then increase the speed to the need one.

4. HOW TO ATTACH A NEEDLE (Fig.2)

CAUTION: Before using the following procedures, be sure to turn the power switch off.

The needle used by this sewing machine is DY×3 26#. During operation, proper needle can be chosen according to the

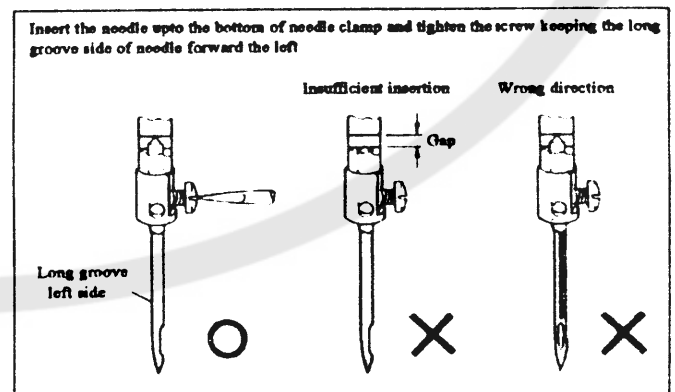

Fig.2

sewing thread. (the sewing thread should be able to pass the pinhole.)

5、 WINDING OF BOBBIN THREAD (Fig.3)

- (1) Push the bobbin ③ on the bobbin winder shaft as far as it will go.
- (2) Bring the thread forward toward the bobbin and wind from below in clockwise direction several times around the bobbin.
- (3) Push the lever ⑤ toward other side so that the driving wheel and driven wheel will engage and then start the machine.
- (4) The driven wheel will automatically be free from the driving wheel and stop after the bobbin is filled with thread.

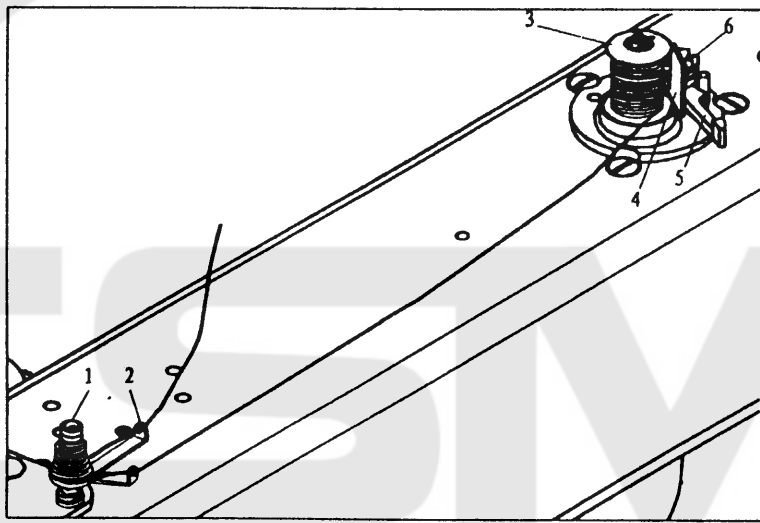

Fig.3

6、 ADJUSTMENT OF THE BOBBIN WINDER (Fig.3)

- (1) In case of uneven winding

If the thread dose not wind evenly on the bobbin, loosen the nut ① and move the bracket ② to the right or to the left as may be required, then tighten the nut.

- (2) Winding amount of thread

Adjusting ⑥ can increase or decrease the amount of thread wound on the bobbin.

(3) Winding strength

Strength of the winding can be adjusted with the nut ①.

7、 THREADING (Fig.4)

Raise the needle bar to its highest position and route the upper thread in the order illustrated below.

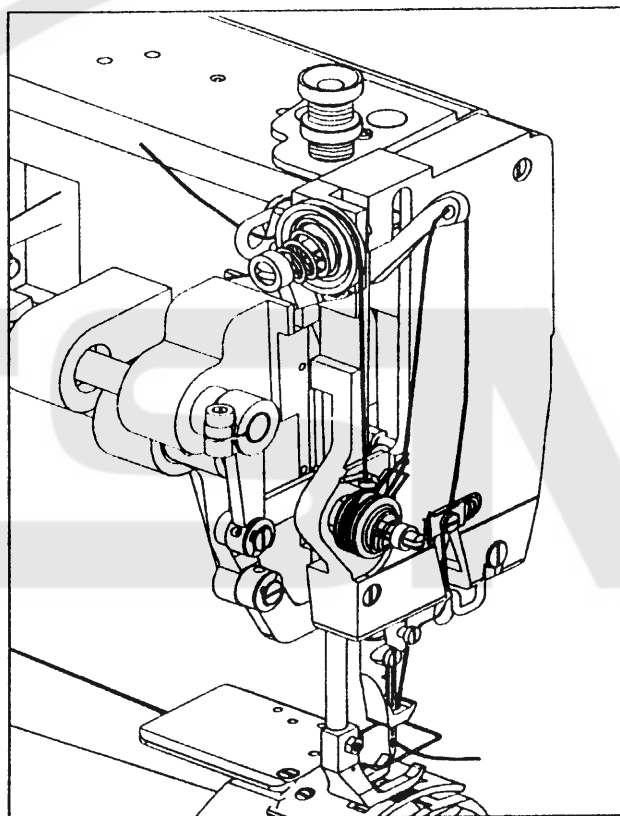

Fig.4

8、 REMOVING AND INSERTING THE BOBBIN

(1) Removing: Open the shuttle race cap and the bobbin holder, then take out the bobbin.

(2) Installation: Put the bobbin in the rotary hook case, Permit about 5 cm of bobbin thread to hand down freely. Install the bobbin in the bobbin case so that the thread wound direction is clockwise. Then close the rotary hook and the shuttle race cap.

9、 ADJUSTING THE THREAD TENSION (Fig.5)

For ordinary stitching, the tension of the upper and the lower threads should be equal.

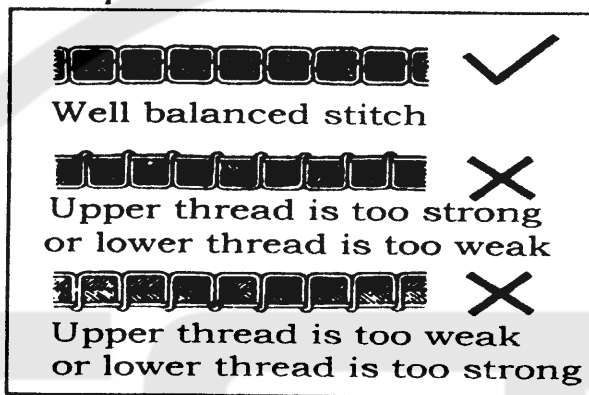

Fig.5

(1) Tension of the Upper thread

Before adjusting the tension of the upper thread, be sure that presser foot is let down. To adjust tension, turn serrated nut on tension device to the right (clockwise) to increase tension and to the left (counter-clockwise) if you desire to decrease the tension.

(2) Tension of the lower thread

The lower thread tension is controlled by the larger screw near the end of the spring at the outside of the bobbin case. Turning this screw to the right (clockwise) will increase the thread tension, while turning it to the left (counter-clockwise) will decrease the tension.

10、 ADJUSTMENT OF PRESSER PRESSURE (Fig.6)

(1) Pressure should be adjusted according to the material to be sewn.

(2) Pressure on both the walking foot and the presser foot can be adjusted. (The adjusting screw has been set before shipment.)

(3) Sewing pressure should be adjusted to the minimum required strength.

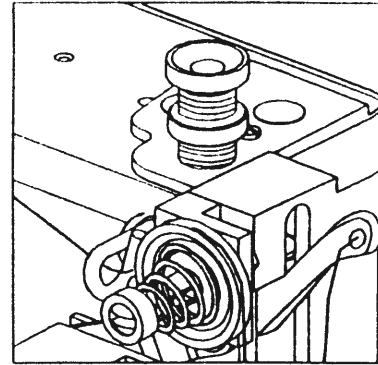

Fig.6

11. ADJUSTMENT OF WALKING FOOT AND PRESSER FOOT (Fig.7)

(1) The alternating movement on the walking foot and presser foot can be adjusted by changing the position relations of the parts of the presser foot lifting mechanism.

(2) Changing the position relation of the connecting link 2 and the crank 3 can complete the adjustment.

(3) Adjustment should be changed according to the thickness of the material to be sewn.

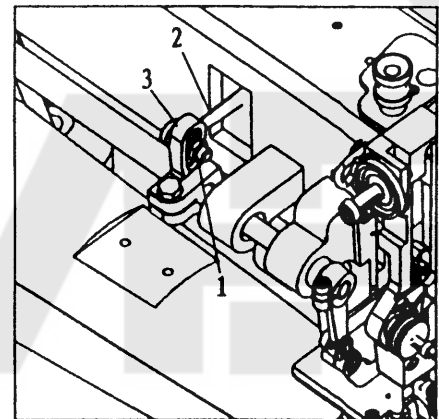

Fig.7

12. ADJUSTMENT OF STITCH LENGTH AND FORWARD/BACKWARD SEWING (Fig.8)

(1) Adjusting the stitch length adjusting bolt can change the stitch length.

(2) Stitch length can be adjusted between 0-11mm.

(3) Setting the stitch length adjusting bolt above “0” can backstitch.

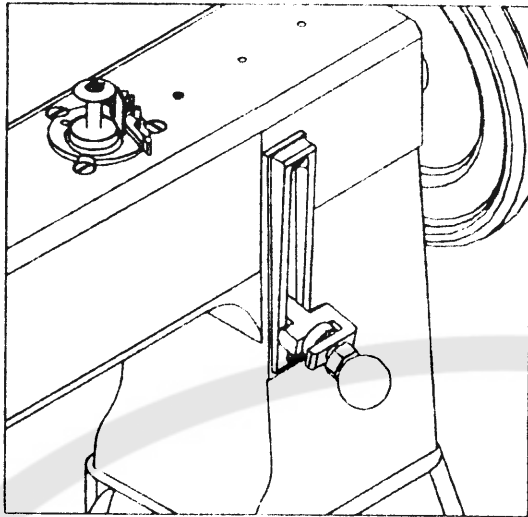

Fig.8

13、 FEED DOG HEIGHT (Fig.9)

The feed dog should be 1.5 mm higher than the vertex of the needle plate. Adjustment of the feed dog height can be done as follows:

- (1) Turn the machine pulley so as to raise the feed dog to its highest point.
- (2) Loosen the screw of the feed dog and adjust the height by raising or lowering it. Then tighten the screw.

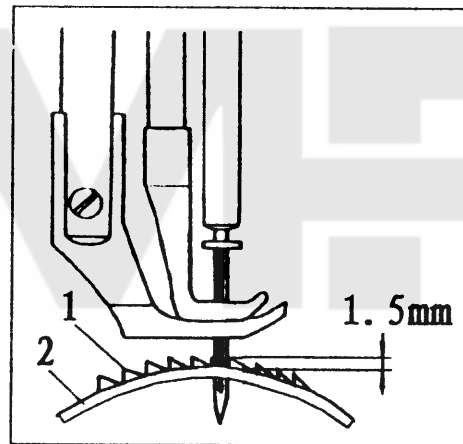

Fig.9

14、 ADJUSTING THE HEIGHT OF THE NEEDLE BAR (Fig.10)

When the needle bar is at its highest point, normally the measurement between the highest point of the needle plate and the

needlepoint is 28 mm. When this distance need to be adjusted, the steps is as follows:

- (1) Take down the face plate, adjust the needle bar to its highest position.
- (2) Loosen the screw of needle bar connecting stud screw.
- (3) Adjust the needle bar to the right position.
- (4) Tighten the screw.

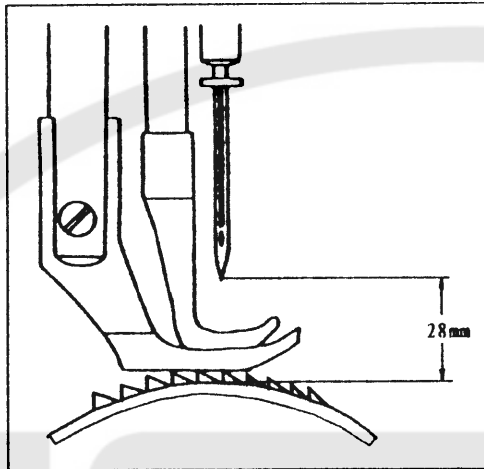
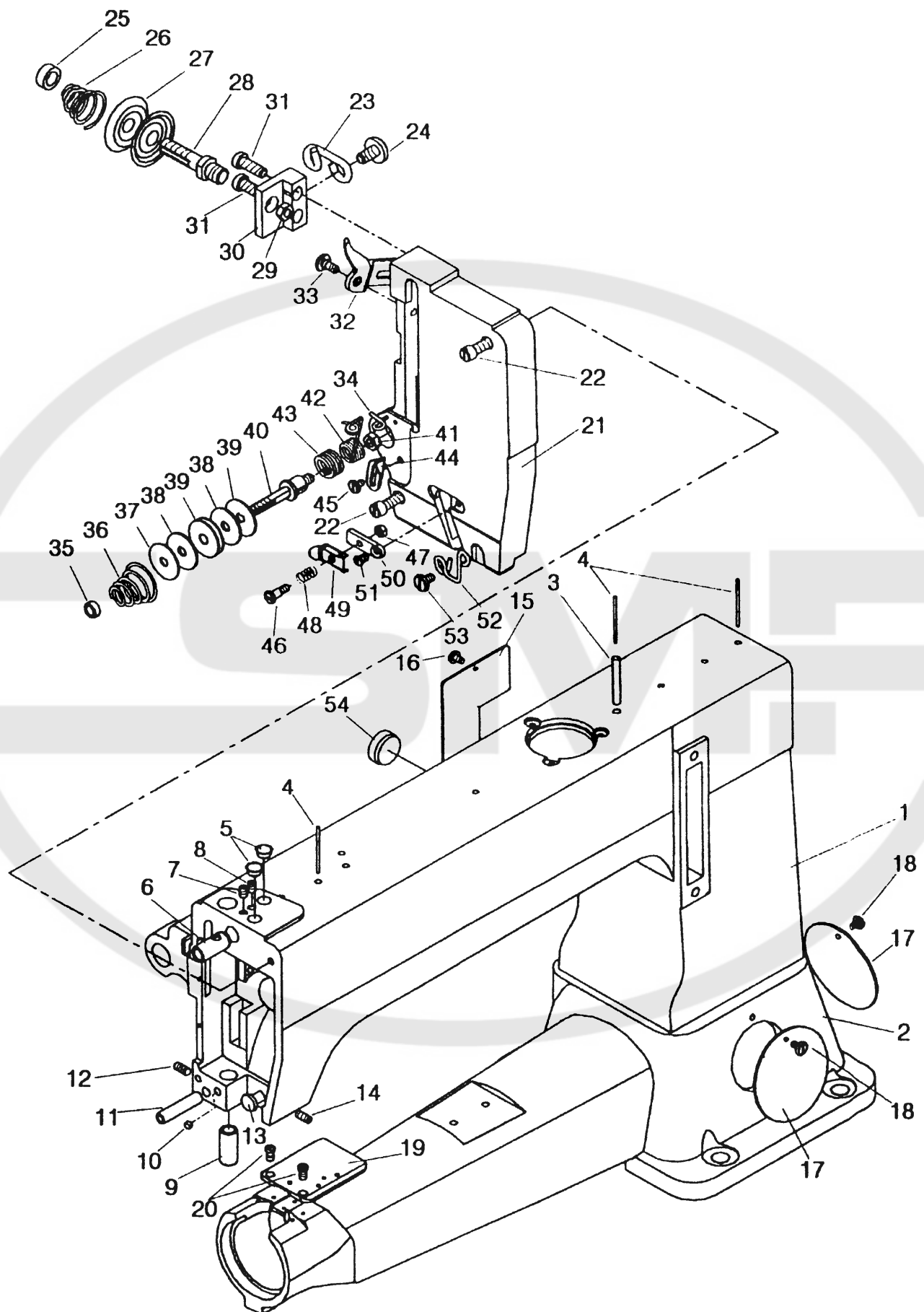

Fig.10

PARTS CATALOG

CSTMP

A: BODY AND ITS ACCESSORIES



A: BODY AND ITS ACCESSORIES

No.	Ref. No.	Description	Pcs.
A1	H7201001	Arm	1
A2	H7201002	Bed	1
A3	H7201003	Oil pipe	1
A4	H7201004	Oil wick	3
A5	H7201005	Rubber plug	2
A6	H7201006	Needle bar guide bracket stud bushing	1
A7	H7201007	Set Screw	1
A8	H7201008	Set Screw	1
A9	H7201009	Presser bar bushing	1
A10	H7201010	Set Screw	1
A11	H7201011	Pin	1
A12	H7201012	Set Screw	1
A13	H7201013	Mandril of needle bar guide bracket	1
A14	H7201014	Set Screw	1
A15	H7201015	Arm side cover	1
A16	H7201016	Screw	1
A17	H7201017	Round cover	2
A18	H7201018	Screw	2
A19	H7201019	Worktable for accessories	1
A20	H7201020	Screw	2
A21	H7201021	Face plate	1
A22	H7201022	Screw	2
A23	H7201023	Thread guide	1
A24	H7201024	Screw	1
A25	H7201025	Nut	1
A26	H7201026	Tension spring	1
A27	H7201027	Tension disc	2
A28	H7201028	Tension screw stud	1
A29	H7201029	Tension nut	1
A30	H7201030	Thread tension regulator complete base	1
A31	H7201031	Screw	2
A32	H7201032	Tension releasing disc	1
A33	H7201033	Screw	1
A34	H7201034	Thread guide	1
A35	H7201035	Tension nut	1
A36	H7201036	Tension spring	1

A: BODY AND ITS ACCESSORIES

No.	Ref. No.	Description	Pcs.
A37	H7201037	Washer	2
A38	H7201038	Felt	2
A39	H7201039	Damping plate	1
A40	H7201040	Tension screw stud	1
A41	H7201041	Nut	1
A42	H7201042	Thread take-up spring	1
A43	H7201043	Spring	1
A44	H7201044	Thread take-up spring guide plate	1
A45	H7201045	Screw	1
A46	H7201046	Screw	1
A47	H7201047	Nut	1
A48	H7201048	Tension spring	1
A49	H7201049	Tension disc	1
A50	H7201050	Thread tension regulator complete base	1
A51	H7201051	Screw	1
A52	H7201052	Thread guide	1
A53	H7201053	Screw	1
A54	H7201054	Rubber plug	1

B: NEEDLE BAR AND THREAD TAKE-UP MECHANISM

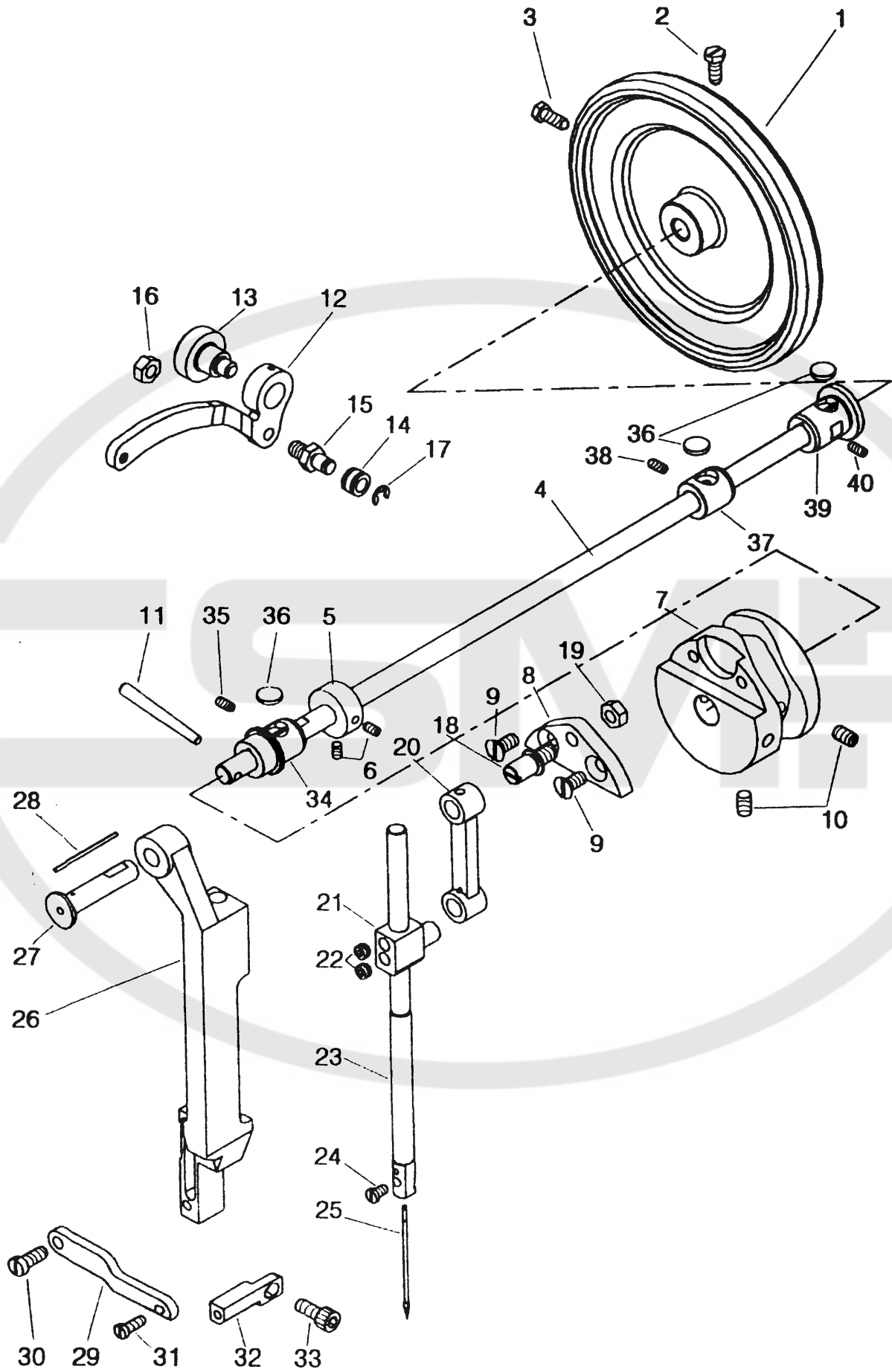

B: NEEDLE BAR AND THREAD TAKE-UP MECHANISM

No.	Ref. No.	Description	Pcs.
B1	H7202001	Pulley	1
B2	H7202002	Screw	1
B3	H7202003	Screw	1
B4	H7202004	Arm shaft	1
B5	H7202005	Collar	1
B6	H7202006	Set Screw	2
B7	H7202007	Thread take-up cam	1
B8	H7202008	Needle bar connecting base link screw	1
B9	H7202009	Screw	2
B10	H7202010	Set Screw	2
B11	H7202011	Pin	1
B12	H7202012	Thread take-up lever	1
B13	H7202013	Screw	1
B14	H7202014	Roller	1
B15	H7202015	Roller pin	1
B16	H7202016	Nut	1
B17	H7202017	Retaining ring-E type	1
B18	H7202018	Needle bar connecting link screw	1
B19	H7202019	Nut	1
B20	H7202020	Needle bar connecting link	1
B21	H7202021	Needle bar connecting stud	1
B22	H7202022	Set Screw	2
B23	H7202023	Needle bar	1
B24	H7202024	Screw	1
B25	H7202025	Needle	1
B26	H7202026	Needle bar guide bracket	1
B27	H7202027	Needle bar guide bracket pin	1
B28	H7202028	Oil wick	1
B29	H7202029	Needle bar guide bracket plate	1
B30	H7202030	Screw	1
B31	H7202031	Screw	1
B32	H7202032	Needle bar guide bracket plate base	1
B33	H7202033	Screw	1
B34	H7202034	Bushing	1
B35	H7202035	Set Screw	1
B36	H7202036	Felt	3

B: NEEDLE BAR AND THREAD TAKE-UP MECHANISM

No.	Ref. No.	Description	Pcs.
B37	H7202037	Bushing	1
B38	H7202038	Set Screw	1
B39	H7202039	Bushing	1
B40	H7202040	Set Screw	1

C: LOWER SHAFT MECHANISM

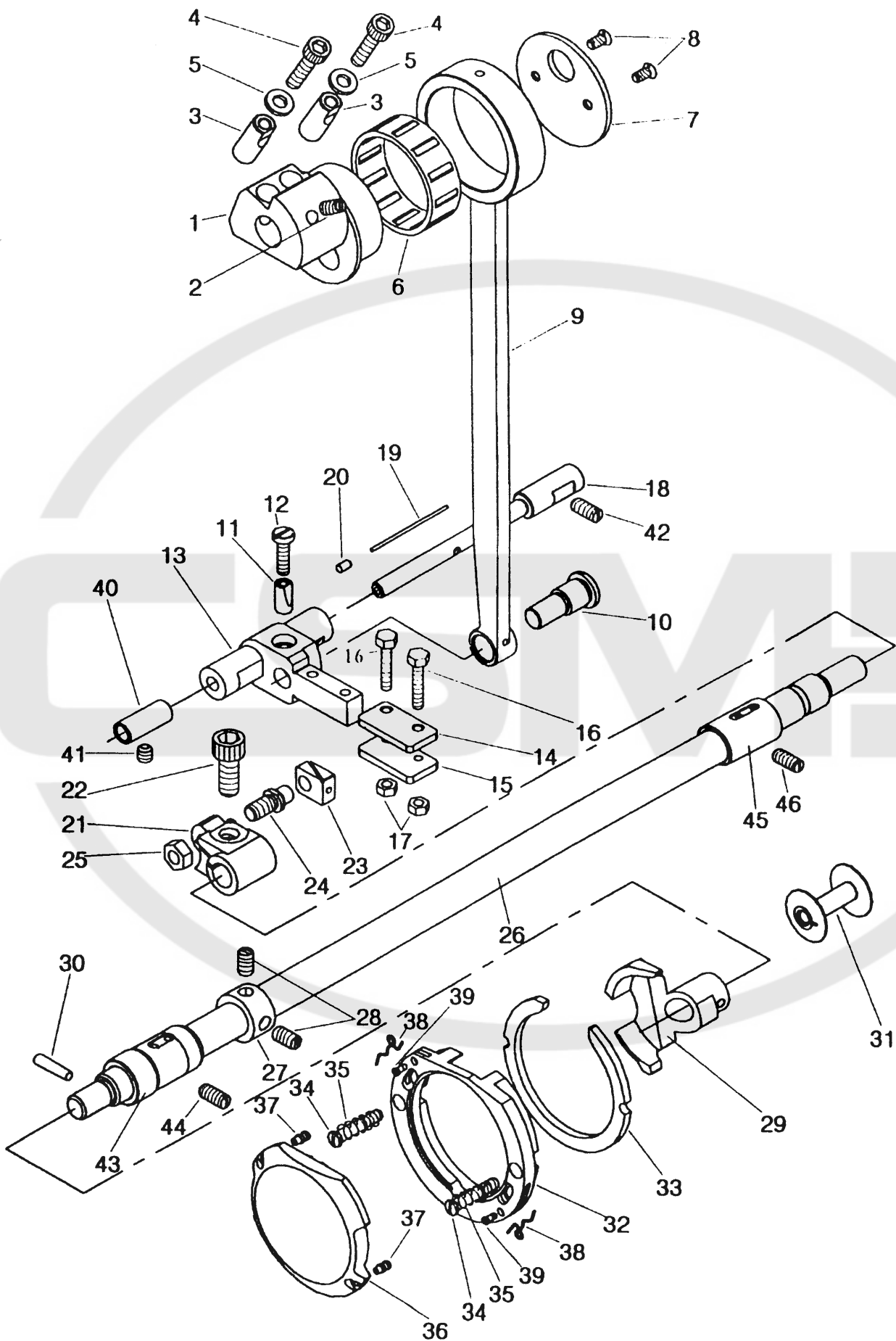

C: LOWER SHAFT MECHANISM

No.	Ref. No.	Description	Pcs.
C1	H7203001	Eccentric	1
C2	H7203002	Set Srew	1
C3	H7203003	pin	2
C4	H7203004	Screw	2
C5	H7203005	Washer	2
C6	H7203006	Bearing	1
C7	H7203007	Eccentric cover	1
C8	H7203008	Screw	2
C9	H7203009	Crank connecting rod	1
C10	H7203010	Crank connecting rod pin	1
C11	H7203011	Pin	1
C12	H7203012	Screw	1
C13	H7203013	Shuttle shaft	1
C14	H7203014	Plate	1
C15	H7203015	Plate	1
C16	H7203016	Screw	2
C17	H7203017	Nut	2
C18	H7203018	Inside Shaft	1
C19	H7203019	Oil wick	1
C20	H7203020	Rivet	1
C21	H7203021	Lower shaft crank	1
C22	H7203022	Screw	1
C23	H7203023	Shuttle shaft slide block	1
C24	H7203024	Screw	1
C25	H7203025	Nut	1
C26	H7203026	Lower shaft	1
C27	H7203027	Collar	1
C28	H7203028	Set Screw	2
C29	H7203029	Shuttle driver	1
C30	H7203030	Pin	1
C31	H7203031	Bobbin	1
C32	H7203032	Shuttle race body	1
C33	H7203033	Shuttle race back ring	1
C34	H7203034	Screw	2
C35	H7203035	Spring	2
C36	H7203036	Shuttle race cap	1

C: LOWER SHAFT MECHANISM

No.	Ref. No.	Description	Pcs.
C37	H7203037	Screw	2
C38	H7203038	Spring	2
C39	H7203039	Screw	2
C40	H7203040	Bushing	1
C41	H7203041	Set Screw	1
C42	H7203042	Set Screw	1
C43	H7203043	Bushing	1
C44	H7203044	Set Screw	1
C45	H7203045	Bushing	1
C46	H7203046	Set Screw	1

D:FEEDING MECHANISM

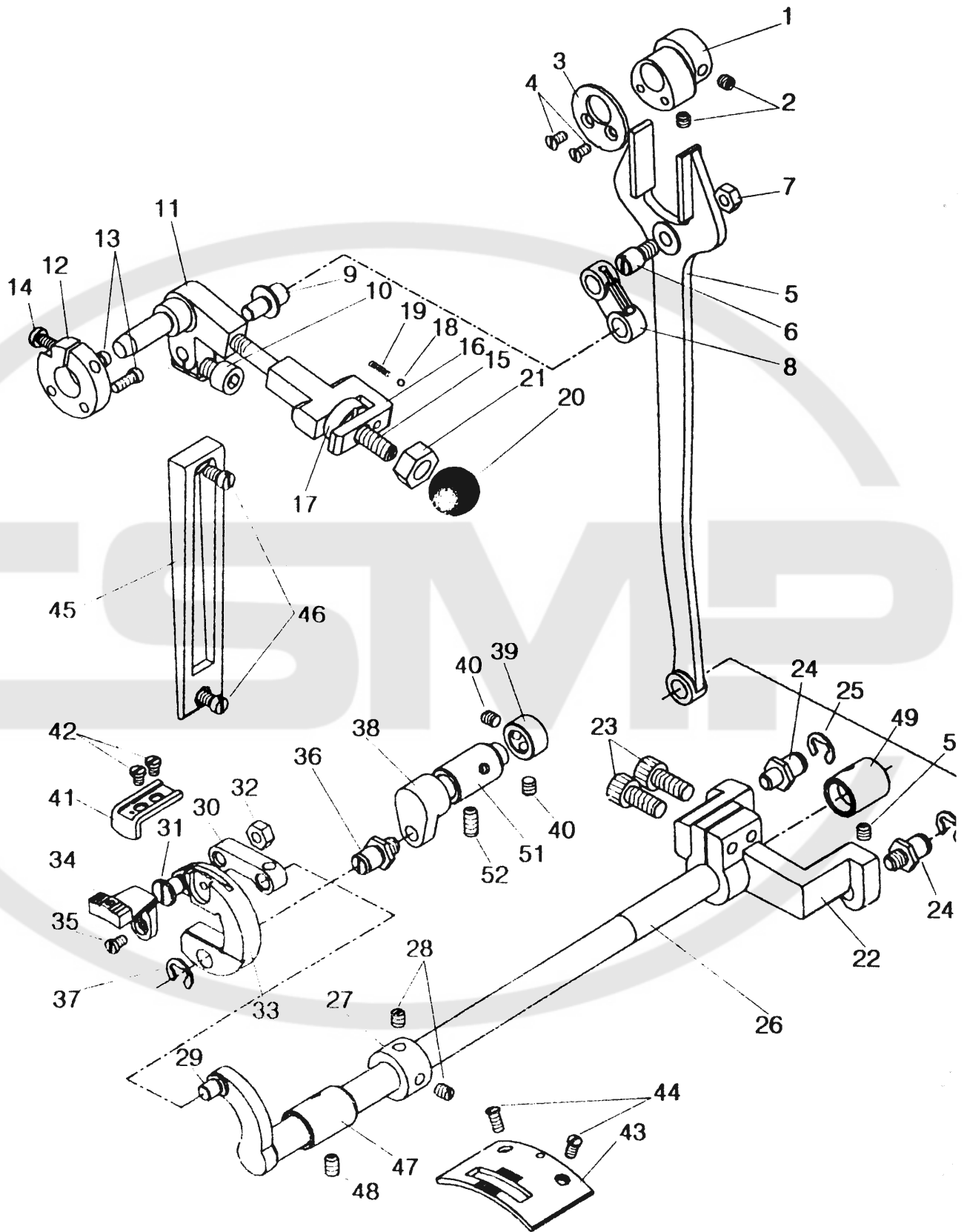

D: FEEDING MECHANISM

No.	Ref. No.	Description	Pcs.
D1	H7204001	Feed cam	1
D2	H7204002	Set Screw	2
D3	H7204003	Feed cam cover	1
D4	H7204004	Screw	2
D5	H7204005	Feed forked connection	1
D6	H7204006	Feed forked connection crank pin	1
D7	H7204007	Nut	1
D8	H7204008	Stitch length connecting link	1
D9	H7204009	Stitch length connecting link crank pin	1
D10	H7204010	Screw	1
D11	H7204011	Stitch length adjusting pin	1
D12	H7204012	Damping plate	1
D13	H7204013	Screw	2
D14	H7204014	Screw	1
D15	H7204015	Stitch length adjusting bolt	1
D16	H7204016	Stitch length limited plate	1
D17	H7204017	Nut	1
D18	H7204018	Metal ball	1
D19	H7204019	Spring	1
D20	H7204020	Plastic ball	1
D21	H7204021	Nut	1
D22	H7204022	Feed driving rock shaft crank	1
D23	H7204023	Screw	2
D24	H7204024	Feed driving rock shaft crank pin	2
D25	H7204025	Retaining ring-E type	2
D26	H7204026	Feed driving rock shaft	1
D27	H7204027	Collar	1
D28	H7204028	Set Screw	2
D29	H7204029	Crank pin	1
D30	H7204030	Feed driving connecting link	1
D31	H7204031	Feed driving connecting link crank pin	1
D32	H7204032	Nut	1
D33	H7204033	Feed dog base	1
D34	H7204034	Feed dog	1
D35	H7204035	Screw	1
D36	H7204036	Feed lifting rock shaft crank pin	1

D: FEEDING MECHANISM

No.	Ref. No.	Description	Pcs.
D37	H7204037	Retaining ring-E type	1
D38	H7204038	Feed lifting rock shaft	1
D39	H7204039	Collar	1
D40	H7204040	Set Screw	2
D41	H7204041	Feed dog base limited plate	1
D42	H7204042	Screw	2
D43	H7204043	Needle plate	1
D44	H7204044	Screw	2
D45	H7204045	Stitch length indicating plate	1
D46	H7204046	Screw	2
D47	H7204047	Bushing	1
D48	H7204048	Set Screw	1
D49	H7204049	Bushing	1
D50	H7204050	Set Screw	1
D51	H7204051	Bushing	1
D52	H7204052	Set Screw	1

E: PRESSER FOOT MECHANISM

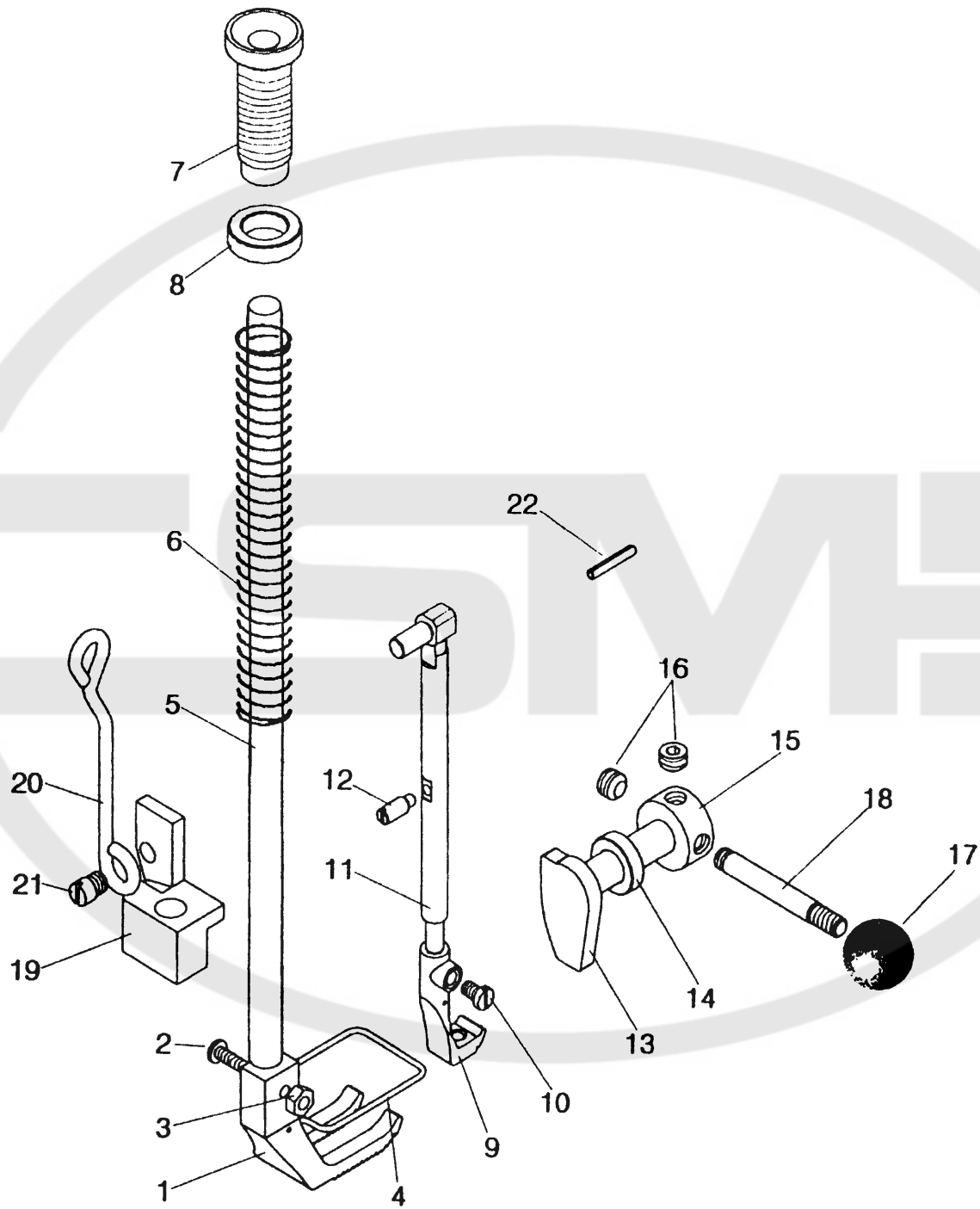

E: PRESSER FOOT MECHANISM

No.	Ref. No.	Description	Pcs.
E1	H7205001	Presser foot	1
E2	H7205002	Screw	1
E3	H7205003	Nut	1
E4	H7205004	Finger guard	1
E5	H7205005	Presser bar	1
E6	H7205006	Presser bar spring	1
E7	H7205007	Thumb screw	1
E8	H7205008	Nut	1
E9	H7205009	Walking foot	1
E10	H7205010	Screw	1
E11	H7205011	Presser bar	1
E12	H7205012	Screw	1
E13	H7205013	Presser bar lifting shaft	1
E14	H7205014	Washer	1
E15	H7205015	Collar	1
E16	H7205016	Set Screw	2
E17	H7205017	Plastic ball	1
E18	H7205018	Bolt	1
E19	H7205019	Presser bar guide bracket	1
E20	H7205020	Connecting rod	1
E21	H7205021	Screw	1
E22	H7205022	Pin	1

F: PRESSER FOOT LIFTING SHAFT MECHANISM

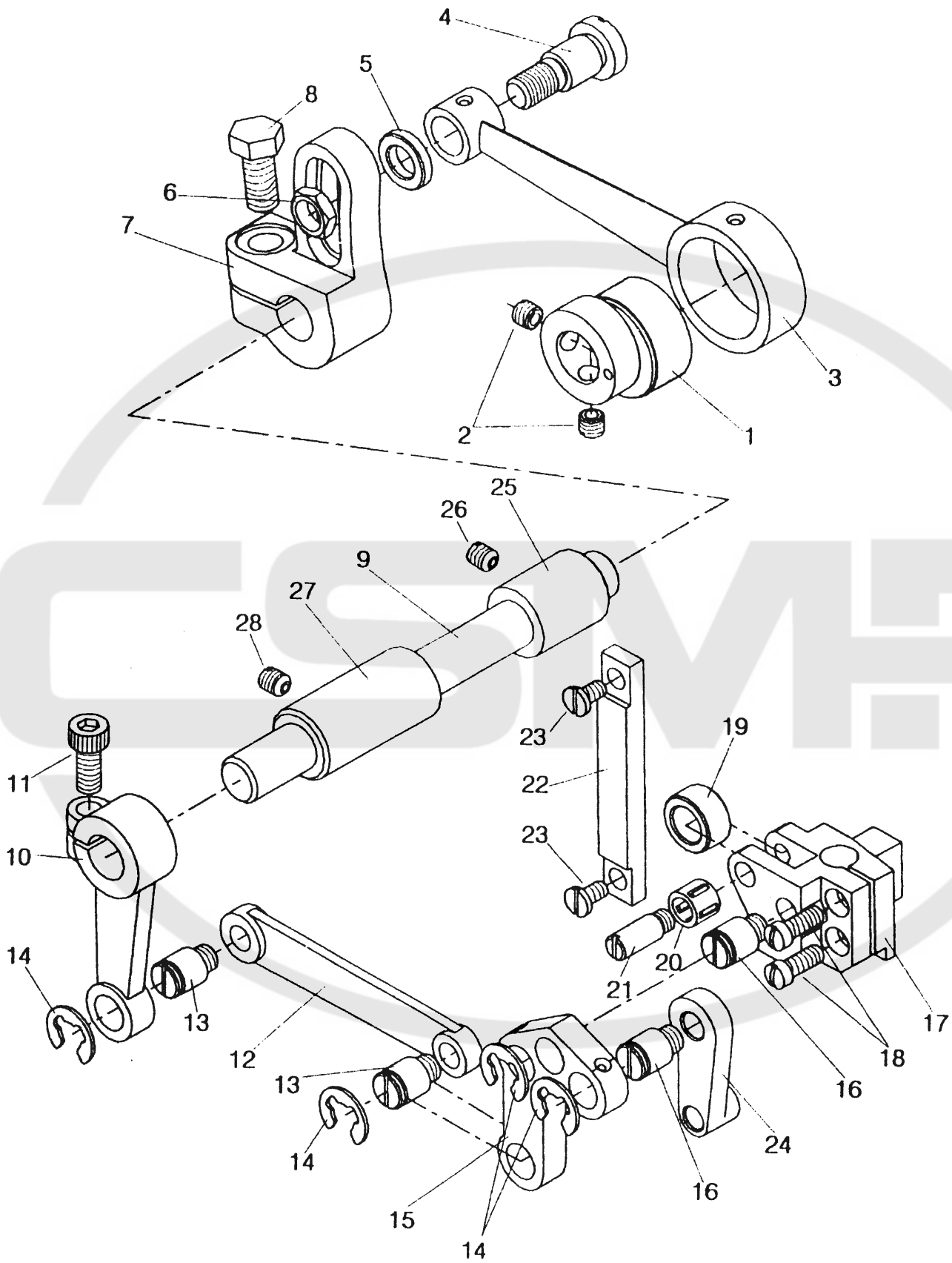

F: PRESSER FOOT LIFTING SHAFT MECHANISM

No.	Ref. No.	Description	Pcs.
F1	H7206001	Presser foot lifting eccentric	1
F2	H7206002	Set Screw	2
F3	H7206003	Eccentric connecting link	1
F4	H7206004	Screw	1
F5	H7206005	Washer	1
F6	H7206006	Nut	1
F7	H7206007	Adjusting crank	1
F8	H7206008	Screw	1
F9	H7206009	Presser foot lifting shaft	1
F10	H7206010	Presser foot lifting shaft crank	1
F11	H7206011	Screw	1
F12	H7206012	Presser foot lifting connecting link	1
F13	H7206013	Screw	2
F14	H7206014	Retaining ring-E type	4
F15	H7206015	Presser foot lifting lever	1
F16	H7206016	Screw	2
F17	H7206017	Presser foot lifting lever base	1
F18	H7206018	Screw	2
F19	H7206019	Roller	1
F20	H7206020	Bearing	1
F21	H7206021	Screw	1
F22	H7206022	Roller base plate	1
F23	H7206023	Screw	2
F24	H7206024	Walking foot lifting connecting link	1
F25	H7206025	Bushing	1
F26	H7206026	Set Screw	1
F27	H7206027	Bushing	1
F28	H7206028	Set Screw	1

G: NEEDLE BAR ROCK SHAFT MECHANISM

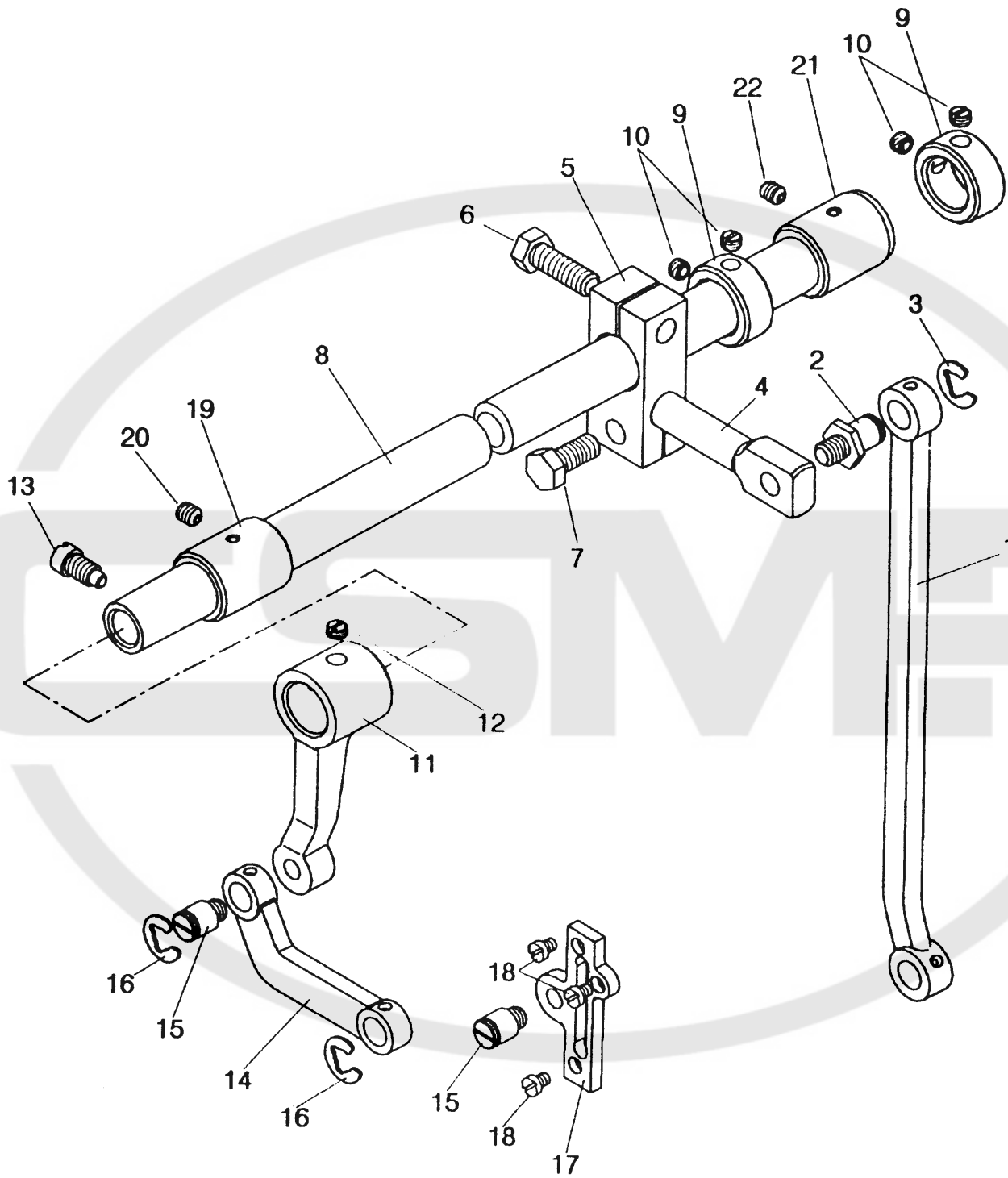

G: NEEDLE BAR ROCK SHAFT MECHANISM

No.	Ref. No.	Description	Pcs.
G1	H7207001	Needle bar rocking connecting link	1
G2	H7207002	Screw	1
G3	H7207003	Retaining ring-E type	1
G4	H7207004	Adjusting crank	1
G5	H7207005	Adjusting crank base	1
G6	H7207006	Screw	1
G7	H7207007	Screw	1
G8	H7207008	Needle bar rock shaft	1
G9	H7207009	Collar	2
G10	H7207010	Set Screw	4
G11	H7207011	Needle bar rocking crank	1
G12	H7207012	Set Screw	1
G13	H7207013	Screw	1
G14	H7207014	Needle bar rocking connecting link	1
G15	H7207015	Screw	2
G16	H7207016	Retaining ring-E type	2
G17	H7207017	Screw base	1
G18	H7207018	Screw	3
G19	H7207019	Bushing	1
G20	H7207020	Set Screw	1
G21	H7207021	Bushing	1
G22	H7207022	Set Screw	1

H: KNEE LIFTER MECHANISM

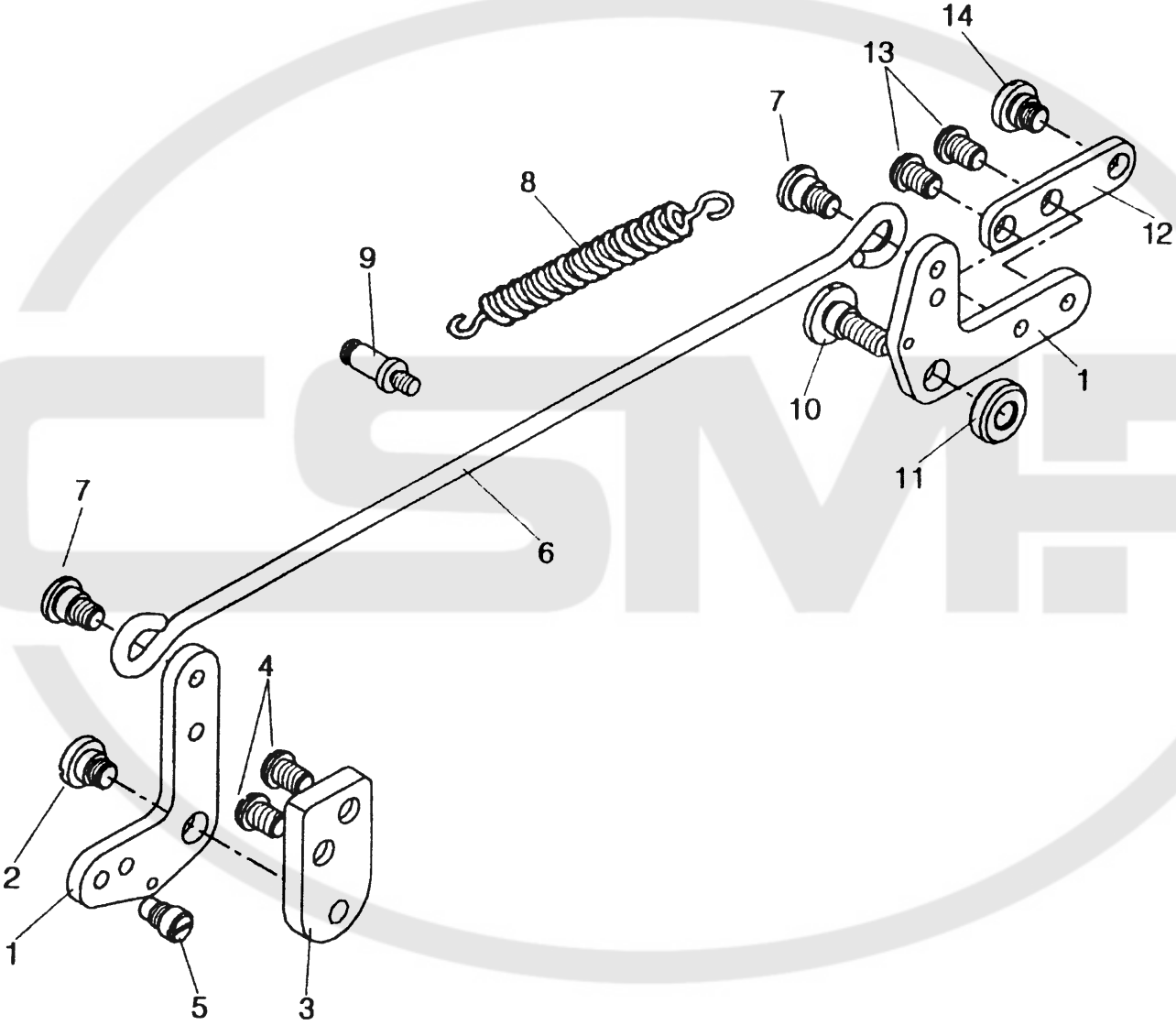

H: KNEE LIFTER MECHANISM

No.	Ref. No.	Description	Pcs.
H1	H7208001	Knee lifter lever	2
H2	H7208002	Screw	1
H3	H7208003	Knee lifter lever base	1
H4	H7208004	Screw	2
H5	H7208005	Screw	1
H6	H7208006	Knee lifter rod	1
H7	H7208007	Screw	2
H8	H7208008	Coil spring	1
H9	H7208009	Screw	1
H10	H7208010	Screw	1
H11	H7208011	Washer	1
H12	H7208012	Knee lifter lever connecting plate	1
H13	H7208013	Screw	2
H14	H7208014	Screw	1

I: BOBBIN WINDER MECHANISM

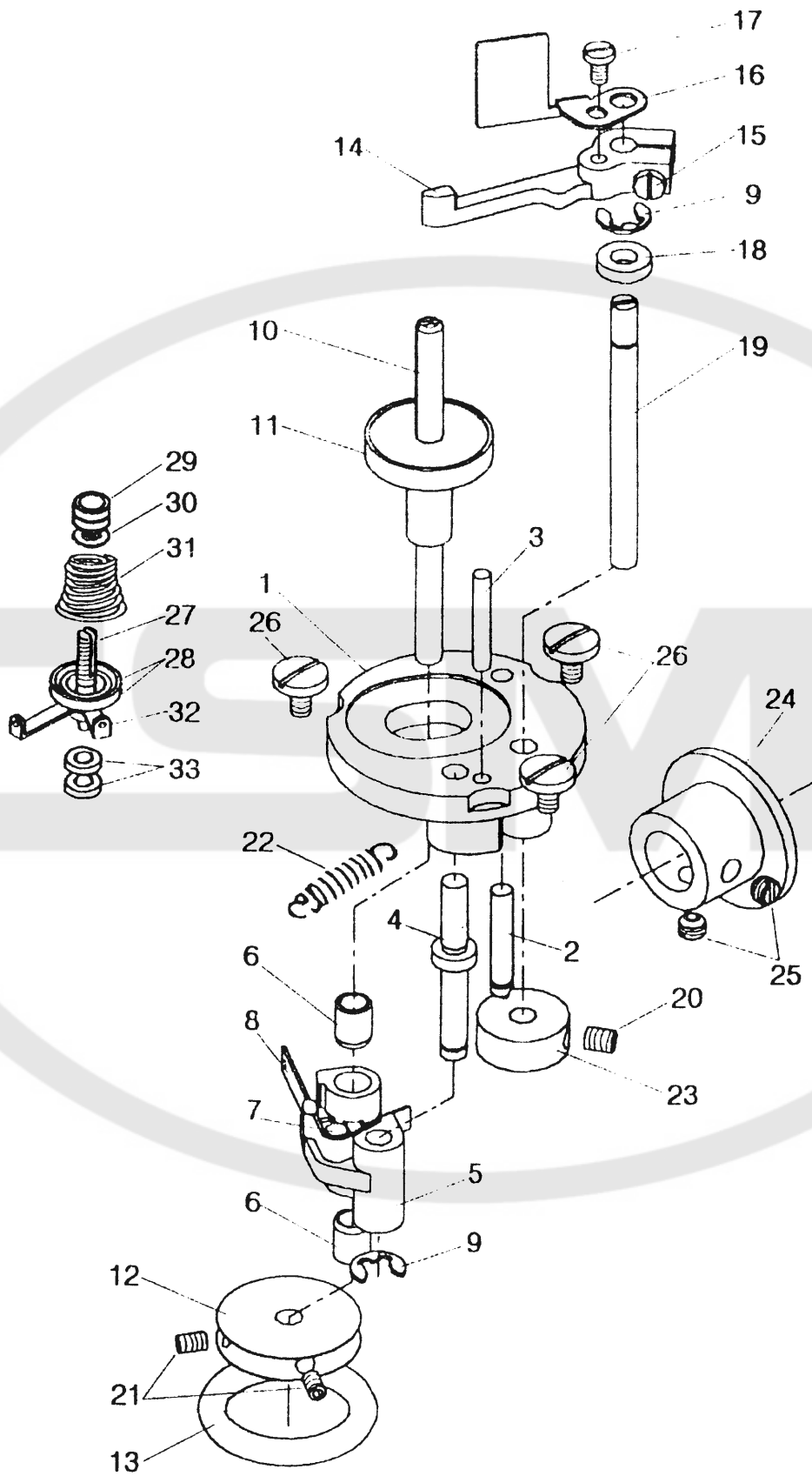

I: BOBBIN WINDER MECHANISM

No.	Ref. No.	Description	Pcs.
I1	H7209001	Bobbin winder plate	1
I2	H7209002	Pin	1
I3	H7209003	Pin	1
I4	H7209004	Bobbin winder crank shaft	1
I5	H7209005	Bobbin winder crank	1
I6	H7209006	Bushing	2
I7	H7209007	Pin	1
I8	H7209008	Bobbin winder spring	1
I9	H7209009	Retaining ring-E type	2
I10	H7209010	Bobbin winder shaft	1
I11	H7209011	Bobbin base	1
I12	H7209012	Driven wheel	1
I13	H7209013	Friction rubber band	1
I14	H7209014	Bobbin winder lever	1
I15	H7209015	Screw	1
I16	H7209016	Winding length limited plate	1
I17	H7209017	Screw	1
I18	H7209018	Washer	1
I19	H7209019	Pin	1
I20	H7209020	Set Screw	1
I21	H7209021	Set Screw	2
I22	H7209022	Spring	1
I23	H7209023	Bobbin winder cam	1
I24	H7209024	Driving wheel	1
I25	H7209025	Set Screw	2
I26	H7209026	Screw	3
I27	H7209027	Screw	1
I28	H7209028	Tension disc	2
I29	H7209029	Nut	1
I30	H7209030	Limited plate	1
I31	H7209031	Spring	1
I32	H7209032	Thread guide	1
I33	H7209033	Washer	2

J: ACCESSORIES

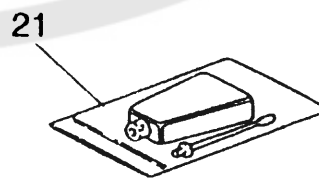
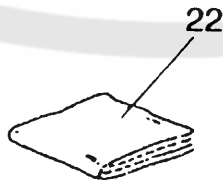
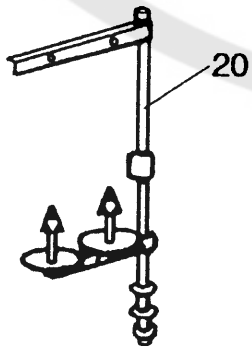
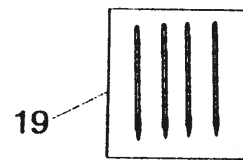
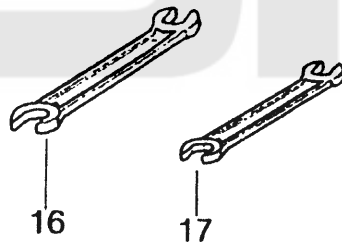
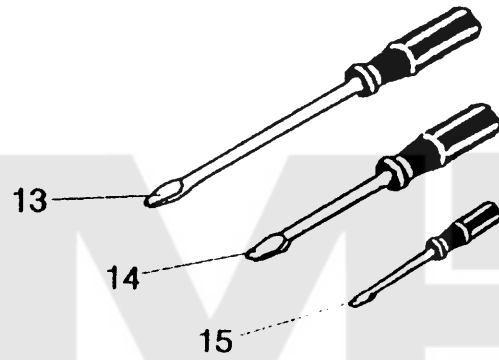
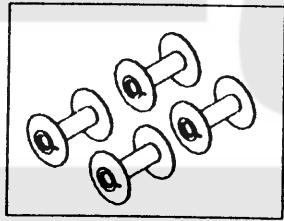
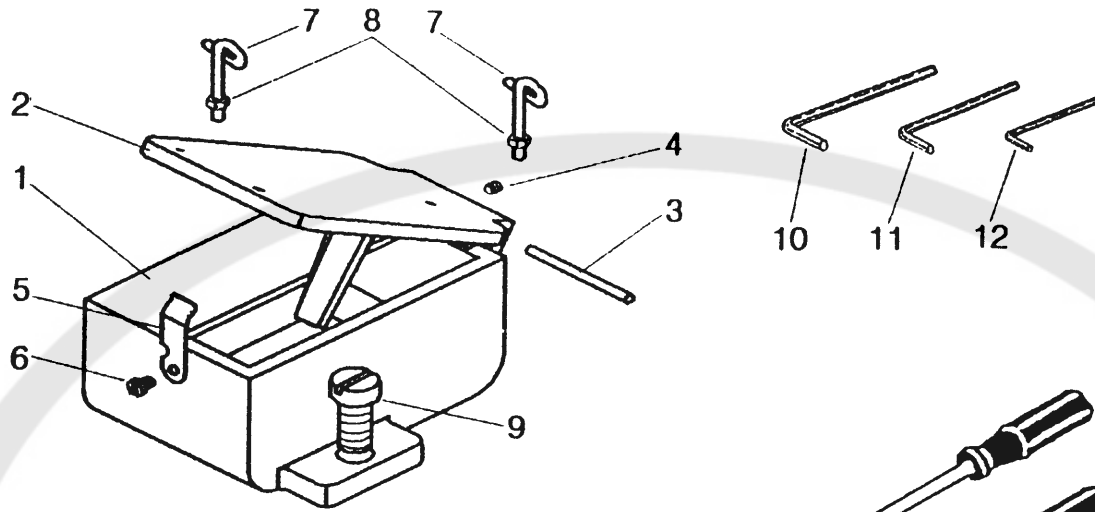

J: ACCESSORIES

No.	Ref. No.	Description	Pcs.
J1	H7210001	Silicon oil box	1
J2	H7210002	Cover	1
J3	H7210003	Pin	1
J4	H7210004	Screw	1
J5	H7210005	Spring	1
J6	H7210006	Screw	1
J7	H7210007	Thread guide	2
J8	H7210008	Nut	2
J9	H7210009	Screw	1
J10	H7210010	Hexagon socket screw key	1
J11	H7210011	Hexagon socket screw key	1
J12	H7210012	Hexagon socket screw key	1
J13	H7210013	Screw driver (size L)	1
J14	H7210014	Screw driver (size M)	1
J15	H7210015	Screw driver (size S)	1
J16	H7210016	Spanner	1
J17	H7210017	Spanner	1
J18	H7210018	Bobbin	4
J19	H7210019	Needle	4
J20	H7210020	Thread stand assy	1
J21	H7210021	Oiler	1
J22	H7210022	Vinyl cover	1