

GLOBAL

INDUSTRIAL SEWING MACHINES

*** **PARTS BOOK /**
INSTRUCTION MANUAL ***

CSTMP

MOD. FOA 925



使用説明書

INSTRUCTION MANUAL

Warning labels

★ The following warning labels appear on the sewing machine. Please follow the instructions on the labels at all times when using the machine. If the labels have been removed or are difficult to read, please contact your nearest Brother Dealer.

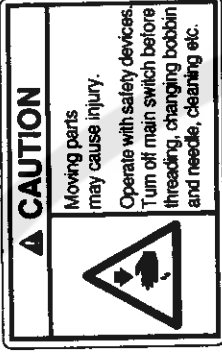

Be sure to connect the ground.
If the ground connection is not
secure, you run the risk of receiv-
ing a serious electric shock.



Direction of operation

Safety devices
● Finger guard
● Thread take-up cover
● Pulley cover, etc.

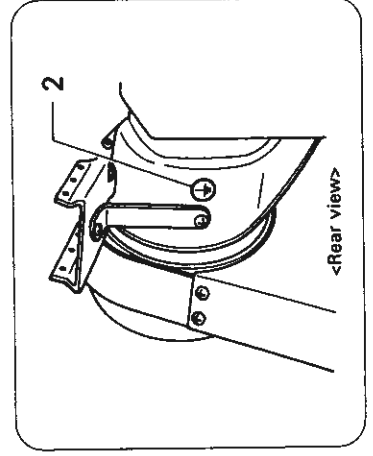
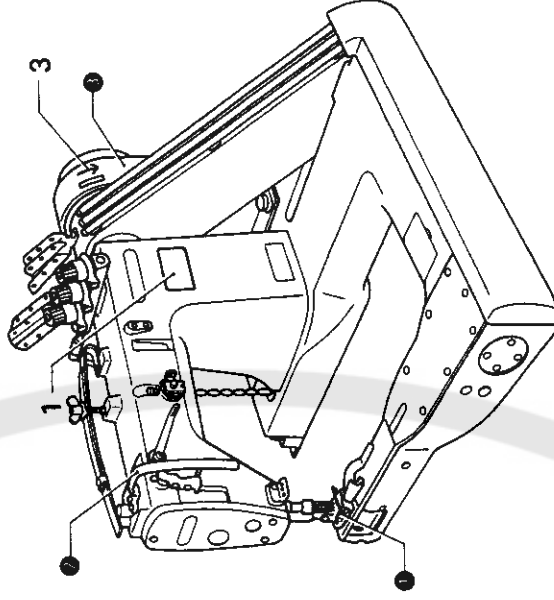

4. WORK TABLE AND MOTOR

Work Table

If using a commercially-available table

- The top of the table should be 40 mm in thickness and should be strong enough to hold the weight and withstand the vibration of the sewing machine.
- Drill holes as indicated in the illustration below.

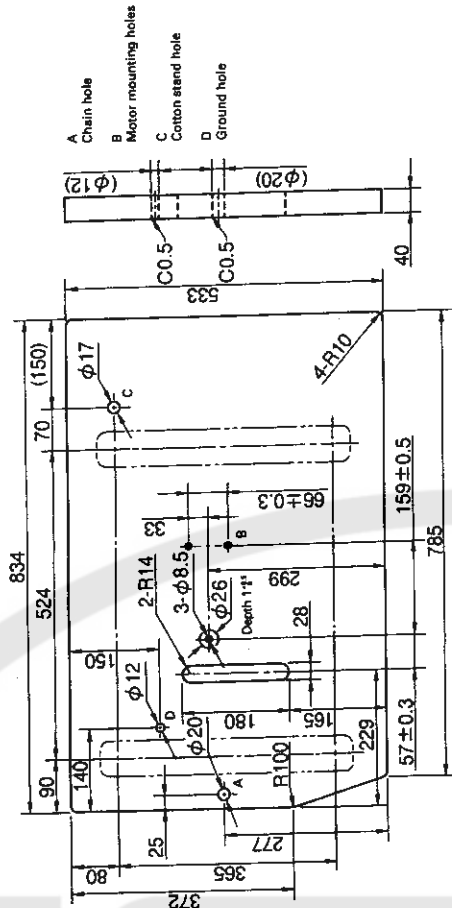

Motor

CAUTION

- All cords which are connected to the motor should be secured at least 25 mm away from any moving parts. Furthermore, do not excessively bend the cords or secure them too firmly with staples, otherwise there is the danger that fire or electric shocks could occur.
- Install the correct belt cover which corresponds to the motor being used.

Motor

- Select the correct motor from those listed in the above table.
- Refer to the instruction manual for the motor for details on installing and using the motor.

Power	Motor
Single-phase	2-pole, 400 W motor
Three-phase	2-pole, 400 W motor

Motor pulley and V-belt

- Refer to the table below to select the motor pulley and belt combination.
- The belt should be an M-type V-belt.

Pulley O.D.	85	90	95	100	105	110	115	120	125	130
Belt size (inches)	M45	M45	M45	M45	M45	M45	M45	M47	M47	M47
Sewing speed (spm)	50Hz	60Hz	3100	3600	3100	4000	3600	4000	3600	4000

1. NAMES OF MAJOR PARTS

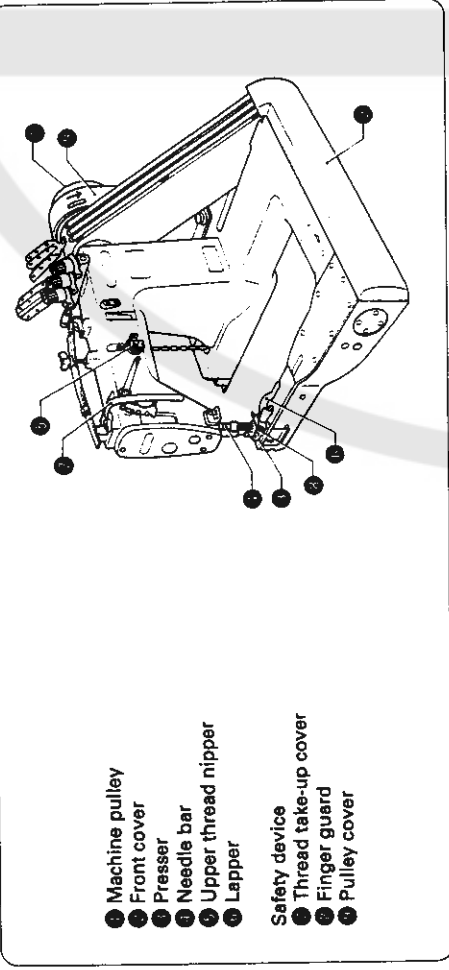

- 1 Machine pulley
- 2 Front cover
- 3 Presser
- 4 Needle bar
- 5 Upper thread nipper
- 6 Lapper
- 7 Safety device
- 8 Thread take-up cover
- 9 Finger guard
- 10 Pulley cover

2. MACHINE SPECIFICATIONS

*3,600 spm for normal operation
When sewing at a speed of 4,000 spm, the needle thread cooler (available as an option) should be used.

Use	For heavy materials			For very heavy materials			Equipped
	None	2	3	heavy	very heavy	heavy	
No. of needles	3	2	3	3			3
Needle (SCHMETZ TV-5)	#120 - #130	#140	#140	#120 - #130	#140	#120 - #130	#140
Needle gauge (mm)	5.67(54.7/64) 6.41(78.1/8) 8.05(72.5/32) 9.63(76.3/16)	4.8(3/16)	5.41(7/4) 6.41(78.1/8) 8.05(72.5/32) 9.63(76.3/16)	#120 - #130 4.8(3/16)	#140 5.41(7/4)	#120 - #130 6.41(78.1/8)	#140 6.41(78.1/8) 8.05(72.5/32) 9.63(76.3/16)
Max. stitch length (mm)	4.2						
Min. arm size (mm)	171						
Max. sewing speed (spm)	4,000* (3,600)	4,000* (3,600)					3,600

3. OPTIONAL PARTS

If the upper thread breaks due to heat, the needle thread cooler device (available as an option) should be used. (Refer to page 21.)

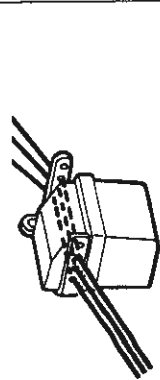

5. INSTALLATION

CAUTION

- The sewing machine should only be installed by a qualified technician.
- Ask your Brother dealer or a qualified electrician for any electrical work that may need to be done.
- The sewing machine weighs more than 49 kg. The installation should be carried out by two or more people.
- Do not connect the power cord until installation is complete, otherwise the machine will operate if the treadle is pressed by mistake, which could result in injury.
- Be sure to connect the ground. If the ground connection is not secure, serious electric shocks will result.
- Install the pulley cover to the machine head.

5-1. Installing the machine head

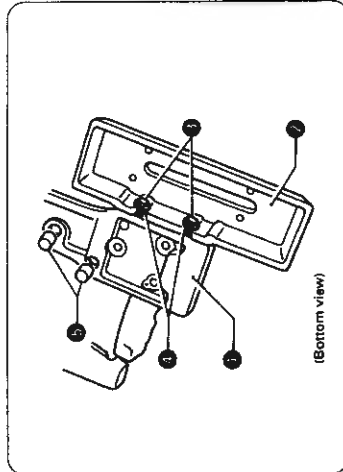

1. Install pulley cover base on machine bed with two hexagonal bolts and two washers.
2. Insert two bar cushions into the holes in the bottom of the bed.

* At this time, install the two hexagonal bolts so that they go as far as possible into the notches in the pulley cover base. Furthermore, check that the pulley cover base is parallel to the bed. (If it is not parallel, the pulley cover may touch the machine pulley.)

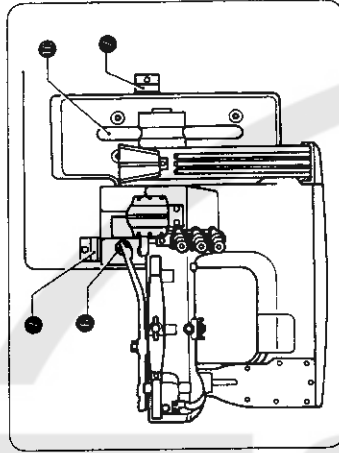
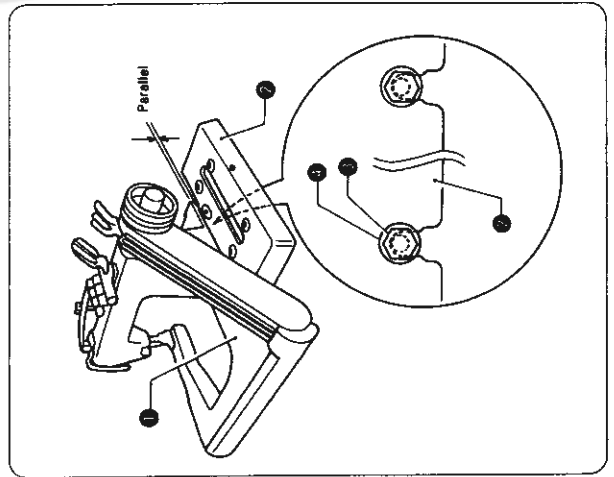

3. Place the machine head on the table, adjust its position in forward and backward directions by aligning it with the hole for presser bar lifter chain, and in side-wise directions by aligning it with belt hole.

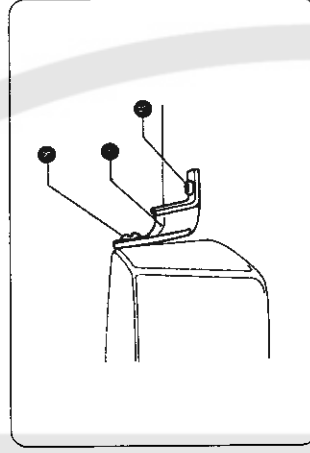

4. After fastening cushions to the machine bed and pulley cover base with set screws, fix them to the table with screws. Place the work table so that the machine head is horizontal. If the machine head is not horizontal, lubrication will not be carried out correctly.

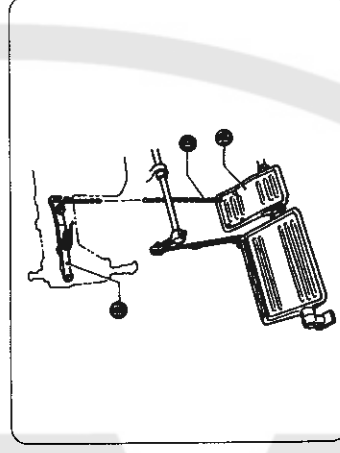

5. Connect the presser bar lifter chain to the knee lifter lever and the presser lifter pedal.

5-2. Ground wire connections

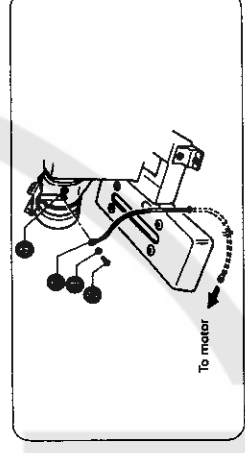

- Connect the ground wire to the sewing machine head and motor.
(Use the correct type of ground wire and washer.)
1. Remove lower thread guide holder screw.
 2. Secure the ground wire to the sewing machine head with screw and washer. (The attachment location is indicated by a ground symbol.)
 3. Pass the ground wire through the hole in the table.
 4. Connect the ground wire to the motor in accordance with the instructions in the instruction manual for the motor.

5. INSTALLATION

5-3. Installing the pulley cover

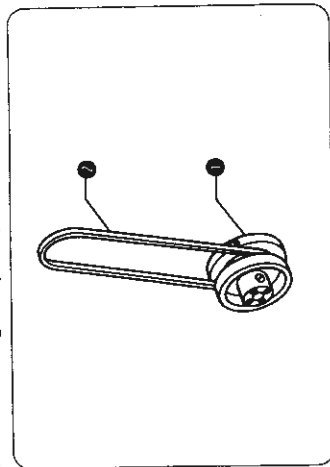

1. Place the belt (1) onto the machine pulley (2).
* Pull the belt (1) upward when installing pulley cover A (3).

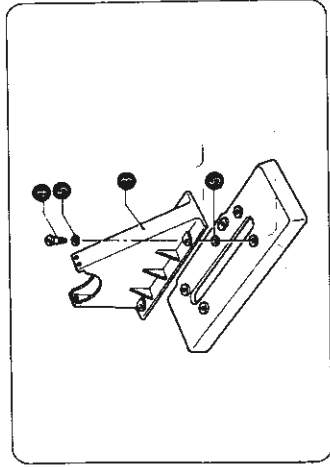

2. Place pulley cover A (3) so that it is in between the eight pulley cover seats (4), and then secure it to the pulley cover base with the four screws (5).

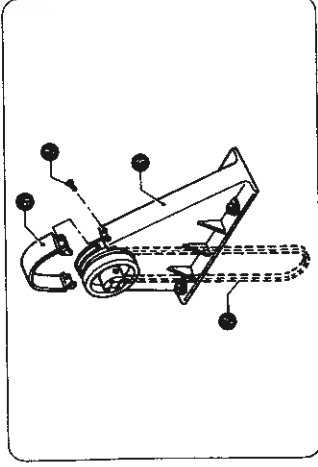

3. Push the belt (1) downward, and then install pulley cover B (4) to pulley cover A (3) with the three screws (6).

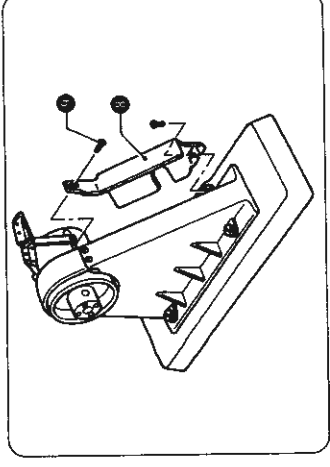

4. If the machine is being used with the pulley attached, install the pulley belt cover (8) with the two screws (7).

5. INSTALLATION

5-4. Belt tension adjustment

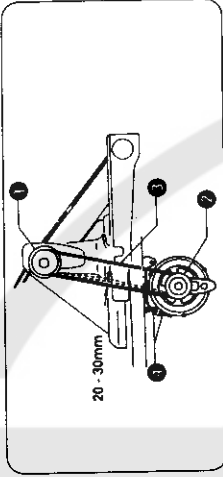

1. Place the V-belt (1) onto the motor pulley (2).
2. Turn the two nuts (3) to adjust so that there is 20 - 30 mm of deflection in the V-belt (1) when it is pressed at the midway point with a force of 9.8 N (1 kgf).

5-5. Cotton stand

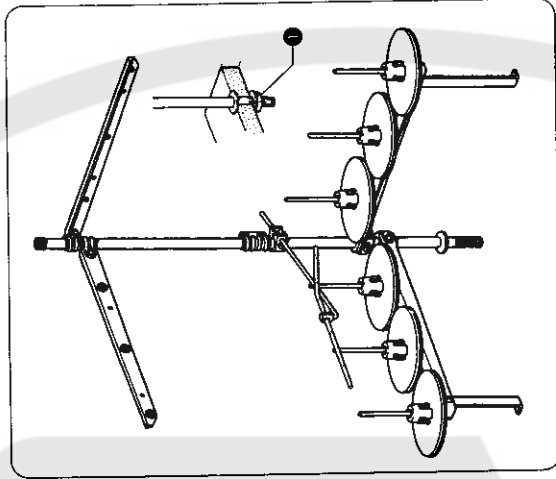

1. Assemble the cotton stand while referring to the cotton stand instruction manual.
2. Install the cotton stand to the cotton stand mounting hole in the work table with the nut (5).

5. INSTALLATION
6. PREPARATION BEFORE SEWING

5-7. Checking the machine pulley rotating direction

CAUTION

- Do not touch any of the moving parts or place any objects against the machine while sewing, as this may result in personal injury or damage to the machine.

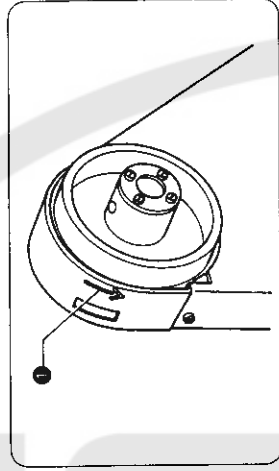

- Insert the power cord plug into the wall outlet, and then turn on the power switch.
- Depress the treadle slightly and check that the machine pulley starts to turn in the direction of the arrow.
 - If the direction of rotation is reversed, change the direction of rotation to the correct direction while referring to the instruction manual for the motor.
 - For the first 3 - 4 days of use, do not run the machine at 500 spm lower than the usual speed. This will help contribute to a longer service life for the machine.

6. PREPARATION BEFORE SEWING

6-1. Needles and threads

The needle and threads to be used vary depending on sewing conditions. Select the correct ones by referring to the table below.

Needle	Thread	
	Upper thread	Lower thread
SCHMETZ TVx5 #130	spun yarn #30	spun yarn #30
#140	spun yarn #20	spun yarn #30

6-2. Installing the needles

CAUTION

- Turn off the power switch before installing the needle, otherwise the machine may operate if the treadle is pressed by mistake, which could result in injury.

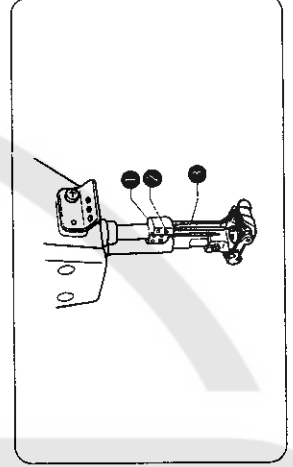

- Turn the pulley until needle holder is raised to the highest position.
- Loosen needle set screws, hold needles with their long grooved side facing front, insert them into needle holder all the way, and fasten the needle with needle set screws.

5. INSTALLATION

5-6. Lubrication

CAUTION

- Be sure to wear protective goggles and gloves when handling the lubricating oil, so that no oil gets into your eyes or onto your skin, otherwise inflammation can result. Furthermore, do not drink the oil under any circumstances, as it can cause vomiting and diarrhoea. Keep the oil out of the reach of children.

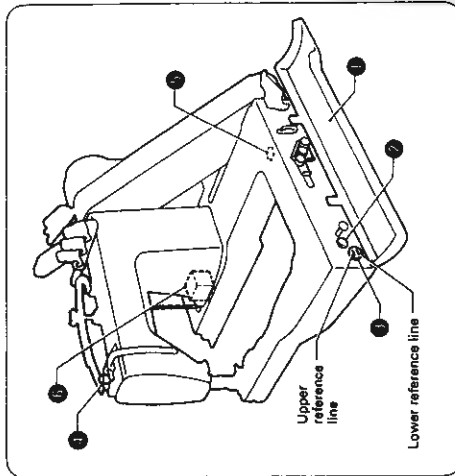

- The sewing machine should always be lubricated and the oil supply replenished before it is used for the first time, and also after long periods of non-use.
- Use only the lubricating oil (Nisseki Sewing Lube 15) specified by Brother.
 - Open the front cover, remove the rubber plug, and then fill with oil until the oil level reaches the point in between the reference lines on the oil gauge.
 - If the oil level drops to the lower reference line, be sure to add more oil.
 - Insert the rubber plug and then close the front cover.
 - Add 1 - 2 drops of oil once a week to needle bar bracket lubrication hole.
 - Periodically loosen the oil drain screw to drain out any oil which collects in the front bed oil sump. After draining the oil, tighten the oil drain screw.
 - Periodically wipe away any oil which collects in the rear bed oil sump with a cloth.

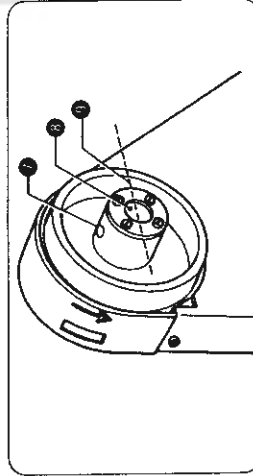

- Turn the machine pulley, so that the oil hole cover is facing upward, and then remove the oil hole cover and fill the oil tank with oil.
 - If the level of lubricating oil drops below the middle reference line on the oil tank, no oil will be drawn into the upper shaft, and the upper shaft will thus not be lubricated sufficiently. Be sure to maintain the lubricating oil level at a level above the center reference line.
- Attach the oil hole cover.

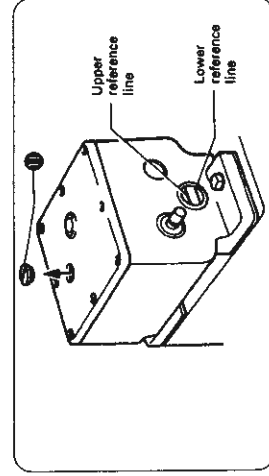

- If the machine is being used with the puller attached, remove the cover screws and fill with oil until the level reaches the upper reference line in the oil sight glass.
- If the oil level drops to the lower reference line, be sure to add more oil. After lubrication is completed, tighten the cover screws.

7. SEWING

CAUTION

- Attach all safety devices before using the sewing machine. If the machine is used without these devices attached, injury may result.
- Turn off the power switch at the following times, otherwise the machine may operate if the treadle is pressed by mistake, which could result in injury.
 - When threading the needle
 - When replacing the needle
 - When not using the machine and when leaving the machine unattended
- Do not touch any of the moving parts or place any objects against the machine while sewing, as this may result in personal injury or damage to the machine.

7-1. Sewing

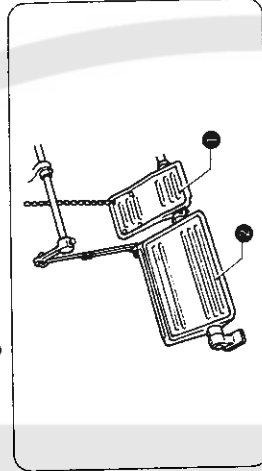

1. Switch the power on.
2. Depress presser lifter pedal ① and place the work under the presser foot.
3. Release the presser lifter pedal.
4. The machine starts running when treadle ② is stepped down.

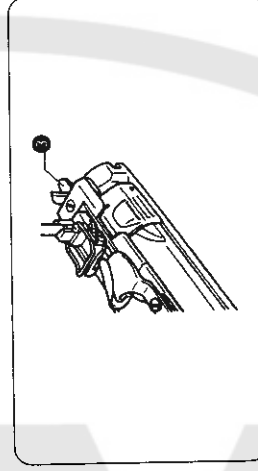

5. After sewing the work, move the work to thread cutter ⑤ to make blank stitches, and cut the thread with it.

6-3. Threading the lower threads

CAUTION

- Turn off the power switch before threading the upper thread, otherwise the machine may operate if the treadle is pressed by mistake, which could result in injury.

Pass the lower threads as shown in the figure below.

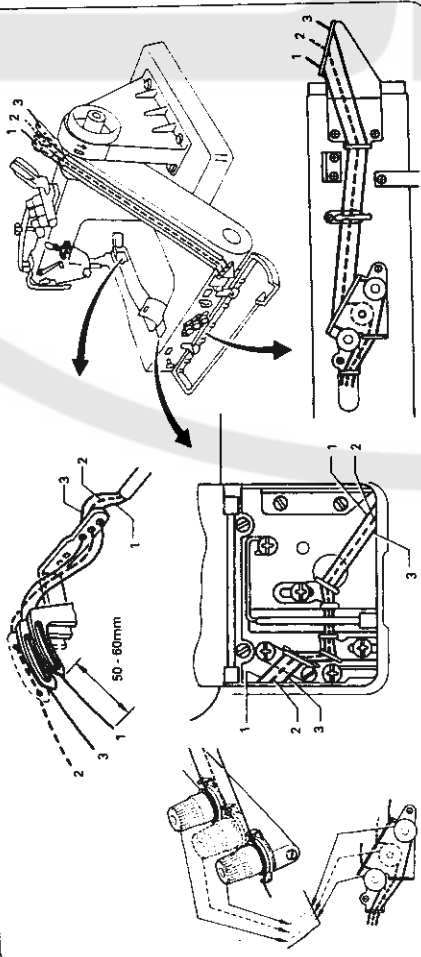

6-4. Threading the upper threads

CAUTION

- Turn off the power switch before threading the upper thread, otherwise the machine may operate if the treadle is pressed by mistake, which could result in injury.

Pass the upper threads as shown in the figure below.

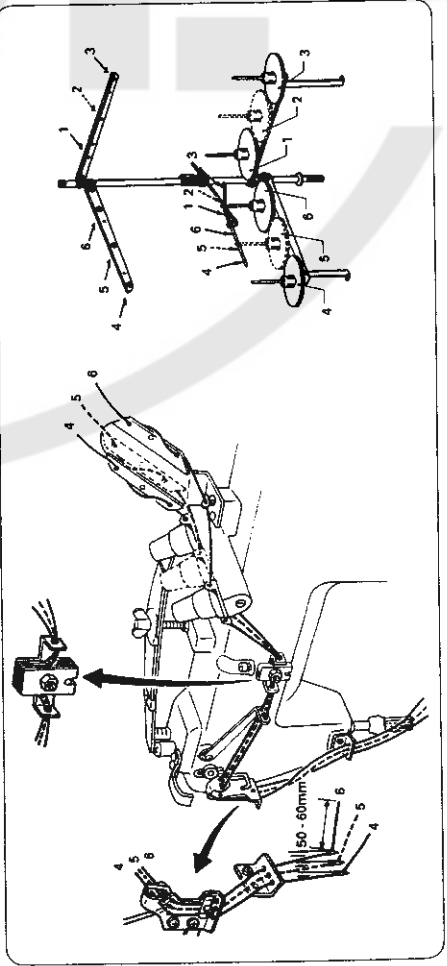

8-3. Adjusting the stitch length

CAUTION



• Turn off the power supply before adjusting the stitch length, otherwise the machine will operate if the treadle is pressed by mistake, which could result in injury. However, the motor will keep turning even after the power is switched off as a result of the motor's inertia. Wait until the motor stops fully before starting work.

- The numerals on the machine pulley scale represent the stitch length (mm), however the actual stitch length will vary depending on the type and thickness of material being used.
- 1. Open the front cover ①.
- 2. While pressing the feed adjustment button ②, turn the machine pulley toward you slowly. (The feed adjustment button ③ will move further inward.)
- 3. While still pressing the feed adjustment button ③, keep turning the machine pulley until the desired numeral appears in the center of the pulley cover windows ④.
- * The higher the value of the numeral, the larger the stitch length becomes.
- Release the feed adjustment button ③.
- (Check that the feed adjustment button ③ pops back out again.)
- 4. Close the front cover ①.

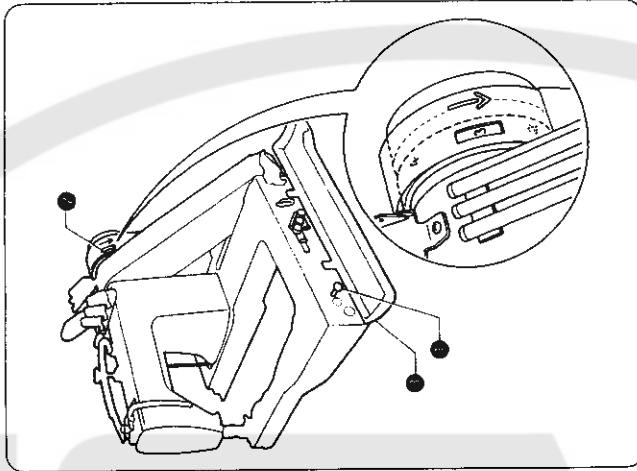

NOTE:

Do not press the feed adjustment button ③ while the machine is operating, as doing so may damage the machine parts.
When sewing with the stitch length set close to the maximum length, you will need to adjust the needle guard in accordance with the type of material and the type of thread being used.

8-4. Puller feed adjustment (Machines with puller)

1. With feed adjusting button ① lightly pressed with your finger, turn the pulley toward yourself until feed adjusting button ② goes in one step deeper.
 2. Keep pressing feed adjusting button ②, and turn the pulley to set your desired feed position on the scale to the reference line.
- The more you turn the pulley toward yourself, the smaller will be the feed.
* Adjust the puller feed after seeing the finished stitches of the work (Refer to page 13).

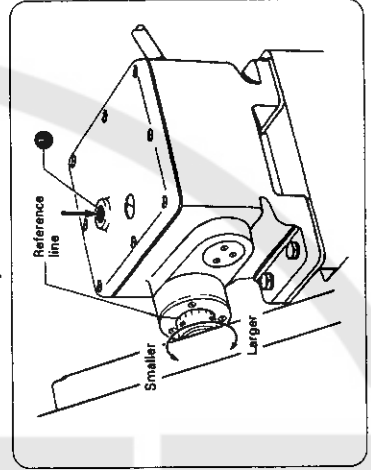

8. THREAD TENSION

8-1. Adjusting the thread tension

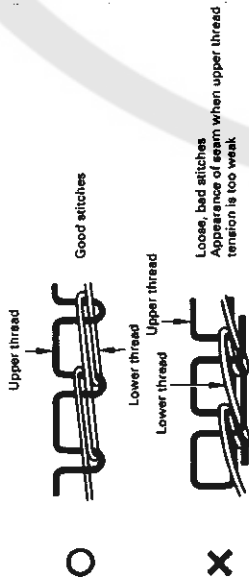

1. Adjust the upper thread tension properly by turning upper thread adjusting screw ①.
2. Adjust the lower thread tension properly by turning lower thread adjusting screw ②.

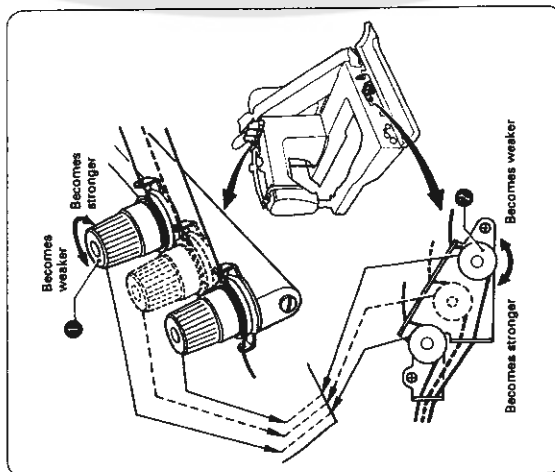

Adjust the presser foot pressure by turning wing nut ① so that the pressure is just enough to feed the work positively and keep the work from slipping.

* In case of Machines with puller the puller pressure can be adjusted as appropriate to the work by turning presser adjusting screw ②.

8-2. Presser foot pressure adjustment

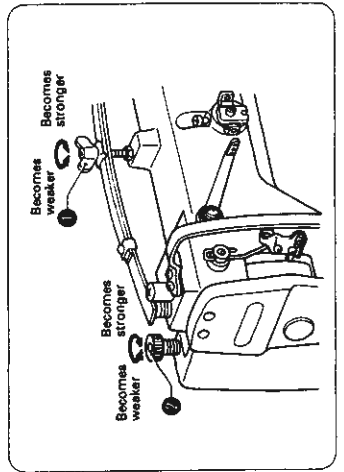

9. CLEANING

The following cleaning operations should be carried out each day in order to maintain the performance of this machine and to ensure a long service life.

CAUTION

- Turn off the power switch before carrying out cleaning. The motor will keep turning even after the power is switched off as a result of the motor's inertia. Wait until the motor stops fully before starting work. The machine may operate if the treadle is pressed by mistake, which could result in injury.
- Be sure to wear protective goggles and gloves when handling the lubricating oil, so that no oil gets into your eyes or onto your skin, otherwise inflammation can result. Furthermore, do not drink the oil under any circumstances, as it can cause vomiting and diarrhoea. Keep the oil out of the reach of children.

9-1. Daily cleaning

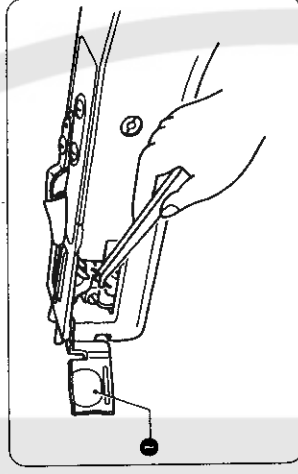

Cleaning the machine

1. Open the looper side plate ① and clean away any thread scraps and other rubbish.
2. After cleaning, close the looper side plate ①.

Lubrication

Refer to "5-6. Lubrication" on page 7.

Checking

1. Check that the threads are threaded correctly. (Refer to page 9.)
2. If the tips of the needles are broken, replace the broken needles.
3. Carry out a trial sewing.

9-2. Changing the lubricating oil (every three months)

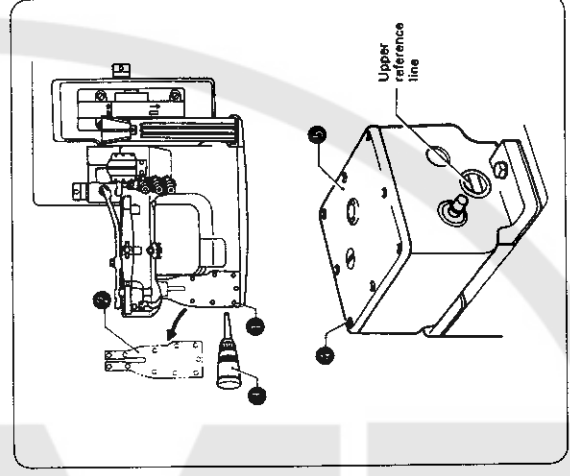

The lubricating oil should be changed at least once every three months.

1. Remove the 11 screws ①, and then open the forward feed arm cover ②.
2. Draw up all of the lubricating oil inside the machine into the oil bottle ③.
3. Fill the machine with oil until the oil level reaches the point in between the reference lines on the oil gauge. (Refer to page 7.)
4. Close the forward feed arm cover ② and secure it with the 11 screws ①.

[Machines with puller]

1. Remove the eight screws ④, and then open the puller top cover ⑤.
2. Draw up all of the lubricating oil inside the machine into the oil bottle ③.
3. Fill the machine with oil until the oil level reaches the top reference line on the oil gauge. (Refer to page 7.)
4. Close the puller top cover ⑤ and secure it with the eight screws ④.

* The table below shows samples of stitches made with a highly elastic fabric and a fabric which is not so elastic. Adjust the puller feed by referring to this table.

Puller feed	Fabric with high elasticity	Fabric with low elasticity
Correct	 Neither non-alignment nor sewing wrinkles.	 Neither non-alignment nor sewing wrinkles.
Insufficient	 Non-aligned, and wrinkled.	 Non-aligned, and wrinkled.
Excessive	 Non-aligned, and very wavy.	 Non-aligned, and very wavy.

10. STANDARD ADJUSTMENTS

CAUTION

- ⊘ Maintenance and inspection of the sewing machine should only be carried out by qualified personnel.
- ⚠ Ask your Brother dealer or a qualified electrician to carry out any maintenance and inspection of the electrical system.
- ⚠ Turn off the power switch and disconnect the power cord from the wall outlet at the following times, otherwise the machine may operate if the treadle is pressed by mistake, which could result in injury. However, the motor will keep turning even after the power is switched off as a result of the motor's inertia. Wait until the motor stops fully before starting work.
- ⚠ When carrying out inspection, adjustment and maintenance
- ⚠ When replacing consumable parts such as the looper

- ⚠ If the power switch needs to be left on when carrying out some adjustment, be extremely careful to observe all safety precautions.
- ⚠ If any safety devices have been removed, be absolutely sure to re-install them to their original positions and check that they operate correctly before using the machine.

10-1. Needle bar height adjustment

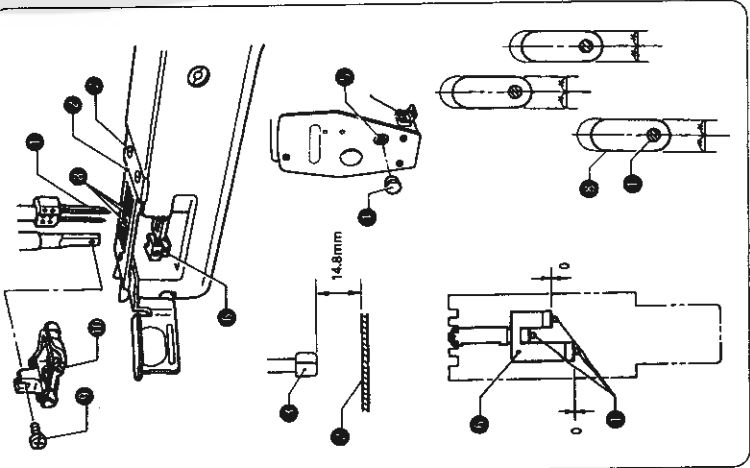

- Adjust the heights of the needles ①. At this time, adjust so that each needle ① is in the center of the needle hole ② in the needle plate ③.
1. Remove the screw ④, and then remove the presser foot ⑤.
 2. Turn the machine pulley to drop the needle bar to its lowest position.
 3. Remove the rubber plug ⑥, loosen the needle bar clamp screw ⑦ and adjust so that the distance between the bottom of the needle clamp ⑧ and the top of the needle plate ⑨ is 14.8 mm.
 - * If the needle clamp is set in the way described above, the distance between the points of the needles ① and the top of the needle plate ⑨ will be 14 mm (for heavy materials and very heavy materials) when the needle clamp ⑧ is raised to its highest position.
 4. Remove the three screws ⑩, and then remove the needle plate ③.
 5. Turn the machine pulley so that the needles ① and the needle guard ⑪ are aligned, and then adjust the tilt of the needle clamp ⑧ so that there is no space between the left and right needles ① and the needle guard ⑪ at this time. Install the needle plate ③ with the three screws ⑩, and after checking that the needles ① are in the centers of the needle holes ②, tighten the needle bar clamp screw ⑦. Insert the rubber plug ⑥ with the screw ④.
 7. Install the presser foot ⑤ with the screw ⑤.

10-2. Needle and looper timing adjustment

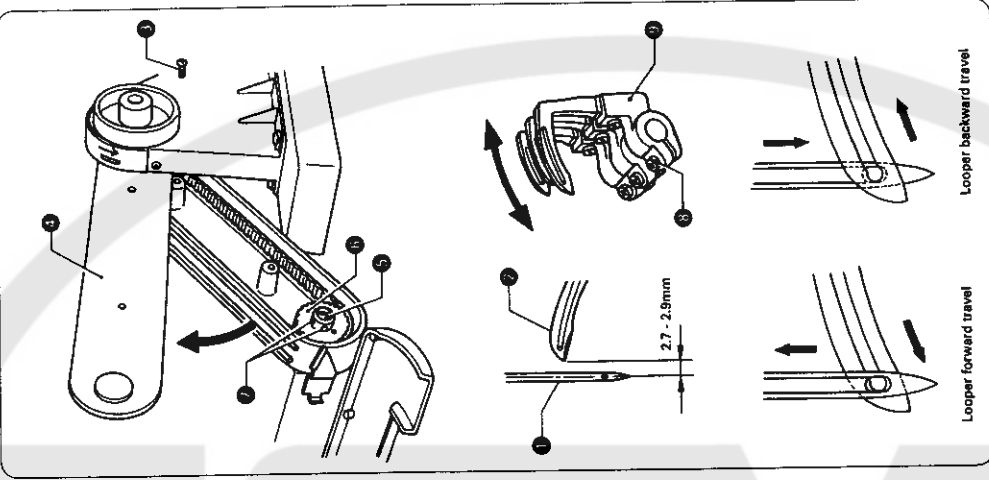

- Make an adjustment so that, when needles ① are down lowest loopers ② reach the end of their backward travel and the distance from the needle center to the looper tip is 2.7 to 2.9 mm.
1. Remove the presser foot, needle plate and feed dogs (Refer to page 15).
 2. Remove the two screws ③, and then open the belt cover plate ④.
 3. Turn the pulley toward yourself until loopers ⑤ reach the end of their backward travel.
 4. Loosen cap screw ⑥, and then loosen two set screws ⑦ on lower belt wheel ⑧, and then loosen two set screws ⑨ turn the pulley toward yourself until needles ① come down to the lowest position.
 6. Tighten two set screws ⑦ securely, and then tighten cap screw ⑥.
 7. Loosen set screw ⑩, move looper holder ⑪ in the arrow direction until the distance between the needle center and the looper tip is 2.7 to 2.9 mm, and retighten set screw ⑩ securely.
 8. Make sure that the looper thread eyes match the needle eyes in the forward and backward travels of the loopers.
 9. Close the belt cover plate ④, and then tighten the two screws ③.
 10. Install the presser foot, needle plate and feed dogs.

10-3. Timing of loopers running clear of needles

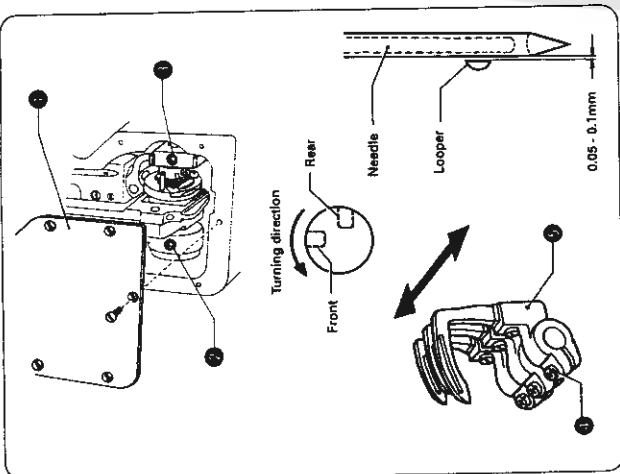

The loopers run in back of the needles in their forward travel and in front of the needles in their backward travel. Adjust the clearance between the needles and the loopers to anywhere from 0.05 to 0.1 mm in the forward travel.

1. Remove forward feed arm cover ①.
2. The forward/back looper timing should be adjusted so that the set screw which is at the rear relative to the forward/back cam turning direction is aligned with the screw adjustment hole ② when the set screw which is at the rear relative to the up/down cam turning direction is aligned with the looper connecting rod adjustment hole ③.
- To adjust, loosen the set screw which is at the front relative to the forward/back cam turning direction, and then loosen the set screw at the rear just enough so that the forward/back cam can be adjusted. After adjusting, tighten the two set screws.
- Loosen the looper holder screw ④, and then move the looper holder ⑤ in the direction of the arrow to adjust so that the clearance between the tip of the looper and the center of the needle is 0.05 - 0.1 mm when the two are aligned. At this time, do not move the looper holder ⑥ in any direction except the direction indicated by the arrow. If it is moved in another direction, carry out the adjustments given in *10-2. Adjusting the needle and looper timing on page 16.
4. Install the forward feed arm cover ①.

10-5. Feed dog height adjustment

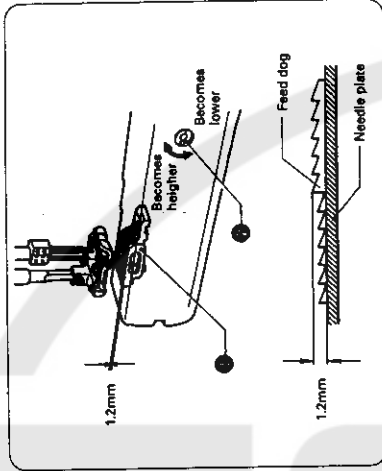

Make an adjustment so that the highest part of the feed dog will be 1.2 mm above the top surface of the needle plate when feed dog ① is at the highest position.

Adjust the height of feed dog ① by turning feed bar eccentric shaft ②.

Installing the Spacer
(For the denim specifications)

If stitch irregularities develop in sewing very heavy materials, adjust the sub-feed dog to the correct height by spacer.

1. Remove set screws ① and sub-feed dog ②.
 2. Place the spacer ③ under sub-feed dog ④ and retighten set screws ①.
- * The spacer is in the parts box.

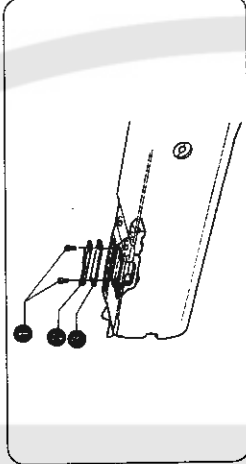

10-4. Needle guard adjustment

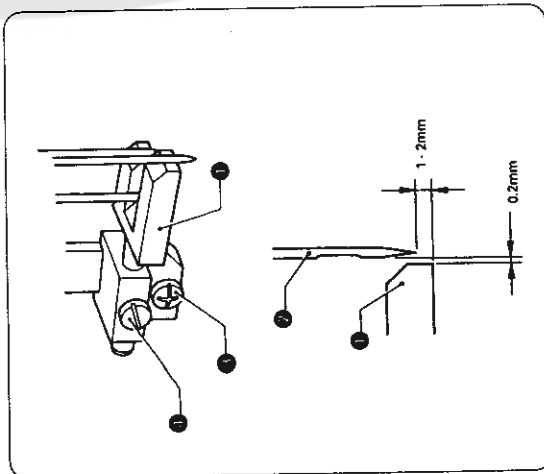

The clearance between the needle guard ① and the needles ② should be 0.2 mm when the stitch length is at the minimum setting and the loopers are moving toward the needles. The heights should be adjusted to as low a setting as possible without the loopers breaking.

1. Adjust the stitch length to the minimum setting. (Refer to page 12.)
2. Turn the machine pulley toward yourself to align the loopers with the centers of the needles.
3. Loosen the set screw ③, and then raise or lower the needle guard ① so that the distance from the bottom of the needle guard ① to the points of the needles is 1 - 2 mm.
4. Tighten the set screw ③.
5. Loosen the set screw ④, and then move the needle guard ① to the left or right to adjust so that the clearance between the needle guard ① and the needles is 0.2 mm.
6. Tighten the set screw ④.

NOTE:

For some materials and threads, the best results can be obtained if the needle guard and the needle are touching slightly when the stitch length is adjusted to the actual stitch length.

10-6. Thread release lever adjustment

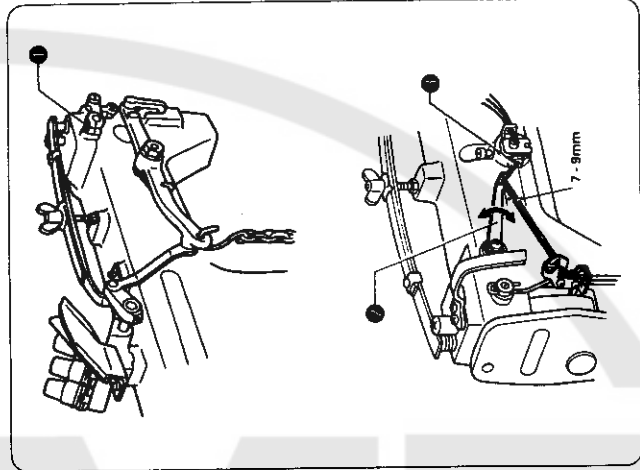

Adjust so that the center of the thread release lever thread hole is 7 - 8 mm above the center of the thread hole in the upper thread tension bracket when the needle bar is at its lowest position.

1. Turn the pulley until the needle bar is down at the lowest position.
 2. Loosen the screw ① and then move the thread release lever ② up or down to adjust so that the center of the thread release lever thread hole is 7 - 9 mm above the center of the thread hole ③ in the upper thread tension bracket.
 3. Retighten set screw ①.
- * The higher the thread release lever, the tighter will be the stitches.

10. STANDARD ADJUSTMENTS

10-7. Upper thread take-up thread guide adjustment

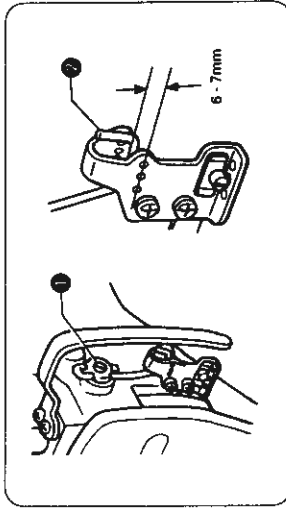

Adjust the distance between the center of the upper thread take-up and the top of the thread guide will be 6 - 7 mm.

1. Turn the pulley toward yourself until the needle bar is down at the lowest position.
2. Loosen the screw ①, and then move the upper thread take-up thread guide ② up or down to adjust so that the distance from the top of the upper thread take-up thread guide ② to the center of the upper thread take-up hole is 6 - 7 mm.

* The higher the upper thread take-up thread guide ②, the greater will be the upper thread loops.

3. Tighten the screw ①.

10-8. Upper thread nipper adjustment

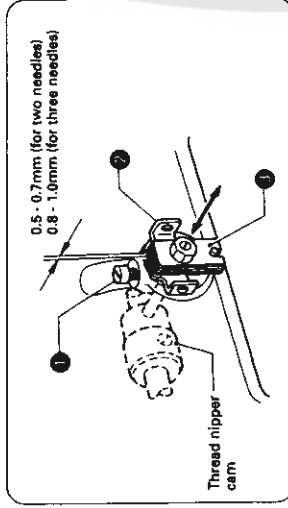

Adjust so that the maximum clearance between the upper thread tension bracket ① and the thread tension plate ② is 0.5 - 0.7 mm (for two needles) or 0.8 - 1.0 mm (for three needles).

Loosen the set screw ③, and then move the upper thread tension bracket ① in or out to adjust so that the maximum clearance between it and the thread tension plate ② is 0.5 - 0.7 mm (for two needles) or 0.8 - 1.0 mm (for three needles).

* The thread tension will become better if the clearance between the upper thread tension bracket ① and the thread tension plate ② is reduced.

10-9. Thread release shaft adjustment

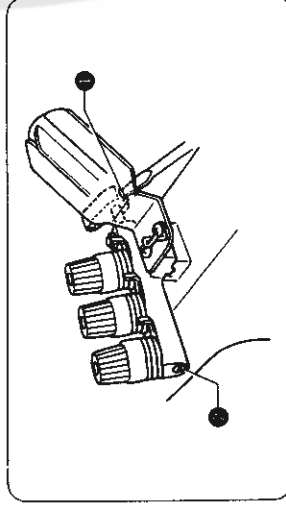

Adjust the thread release shaft so that the thread tension discs loosen when the presser foot is raised and tighten when the presser foot is lowered.

1. Loosen set screw ①.
2. Make an adjustment by turning thread release shaft ② so that the thread tension discs begin to loosen when the presser foot rises 4 mm above the top of the needle plate.
3. After the adjustment, retighten set screw ① securely.

10-10. Lower thread take-up timing adjustment

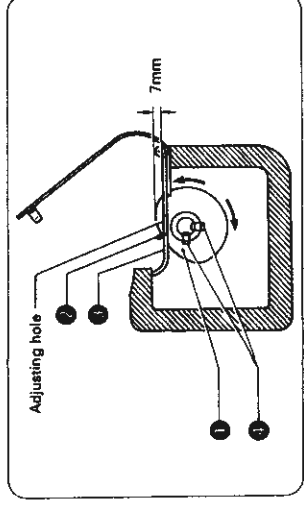

Make an adjustment so that, when the loopers begin moving backward, lower thread take-up ① contacts thread ②, and is 7 mm up from lower thread take-up base ③.

1. Insert screwdriver through the adjusting hole in the lower thread take-up base, and loosen two set screws ①.
2. Raise lower thread take-up ② until it is 7 mm up from thread take-up base ③.
3. After the adjustment, retighten two set screws ① securely.

10. STANDARD ADJUSTMENTS

10-11. Installing the lapper

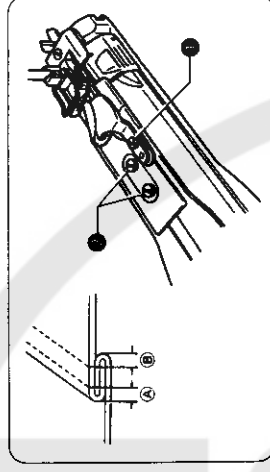

Insert the lapper guide plate from the front into the oval slot in the forward feed arm cover, making sure that the end of lapper is clear of the presser foot.

- **Lapper adjustment**
- Adjust felling distance of point ① by loosening set screw ②.
- After the adjustment, retighten set screw ②.
- Adjust felling distance of point ③ by loosening set screws ④.
- After the adjustment, retighten set screws ④.

10-12. Puller height adjustment (Machines with puller)

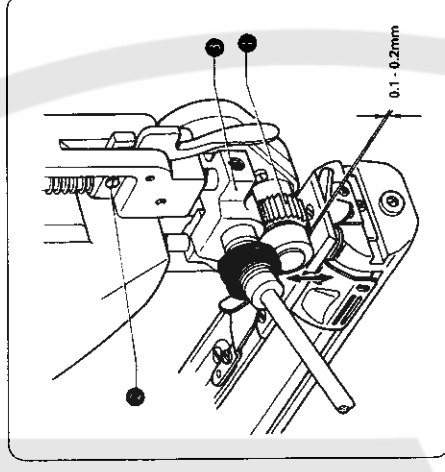

Adjust the height of puller ① so that it is 0.1 to 0.2 mm high from the top of the needle plate.

Loosen set screw ②, and move puller support ③ up or down until puller ① is 0.1 to 0.2 mm above the top of the needle plate.

After the adjustment, retighten set screw ②.

10-13. Puller timing adjustment (Machines with puller)

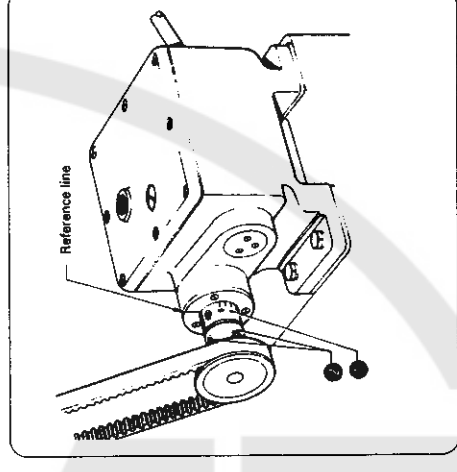

Make an adjust so that, when the needle bar is down at the lowest position, the mark on timing collar ② is in line with the reference line.

1. Turn the pulley toward yourself until the mark on timing collar ② meets the reference line.
2. Loosen two set screws ③, and turn the pulley toward yourself until the needle bar is lowered all the way down.
3. Retighten two set screws ③.

11. INSTALLING OPTIONAL PARTS

CAUTION

- Installation of optional parts should only be carried out by a qualified technician.
- Turn off the power switch and disconnect the power cord before installing any optional parts, otherwise the machine will operate if the treadle is pressed by mistake, which could result in injury.

Needle thread cooler		
NAME OF PARTS	Q'TY	CODE
● Needle thread cooler tank assy	1	S08758-009
● Taptite, Fan P M3×10	2	575456-001
● Felt	1	S08761-100
● Thread guide	1	S08989-101
● Screw, Bind SM 4.37-40×7	2	060680-712
● Silicone oil	1	S06704-001

The parts shown in the illustration at left are necessary when installing the needle thread cooler.

1. Install the needle thread cooler tank assembly ● to the thread guide ● with the two screws ●.
2. Insert the felt ● into the needle thread cooler tank assembly ●.

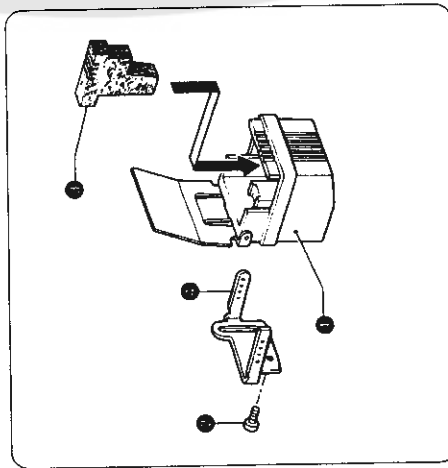

3. Install the needle thread cooler tank assembly ● to the arm with the two screws ●.

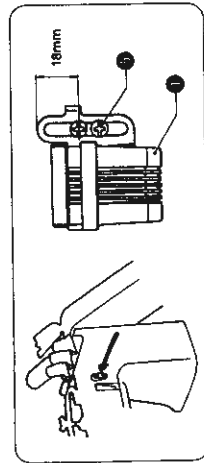

A large, light gray watermark logo is centered on the page. It consists of a semi-circular arc at the top and bottom, with the letters 'CSMP' in a bold, stylized font in the middle. The 'C' is a simple block letter, 'S' is a thick, rounded letter, 'M' is a block letter with a vertical bar, and 'P' is a block letter with a vertical bar.

零件冊

PARTS BOOK

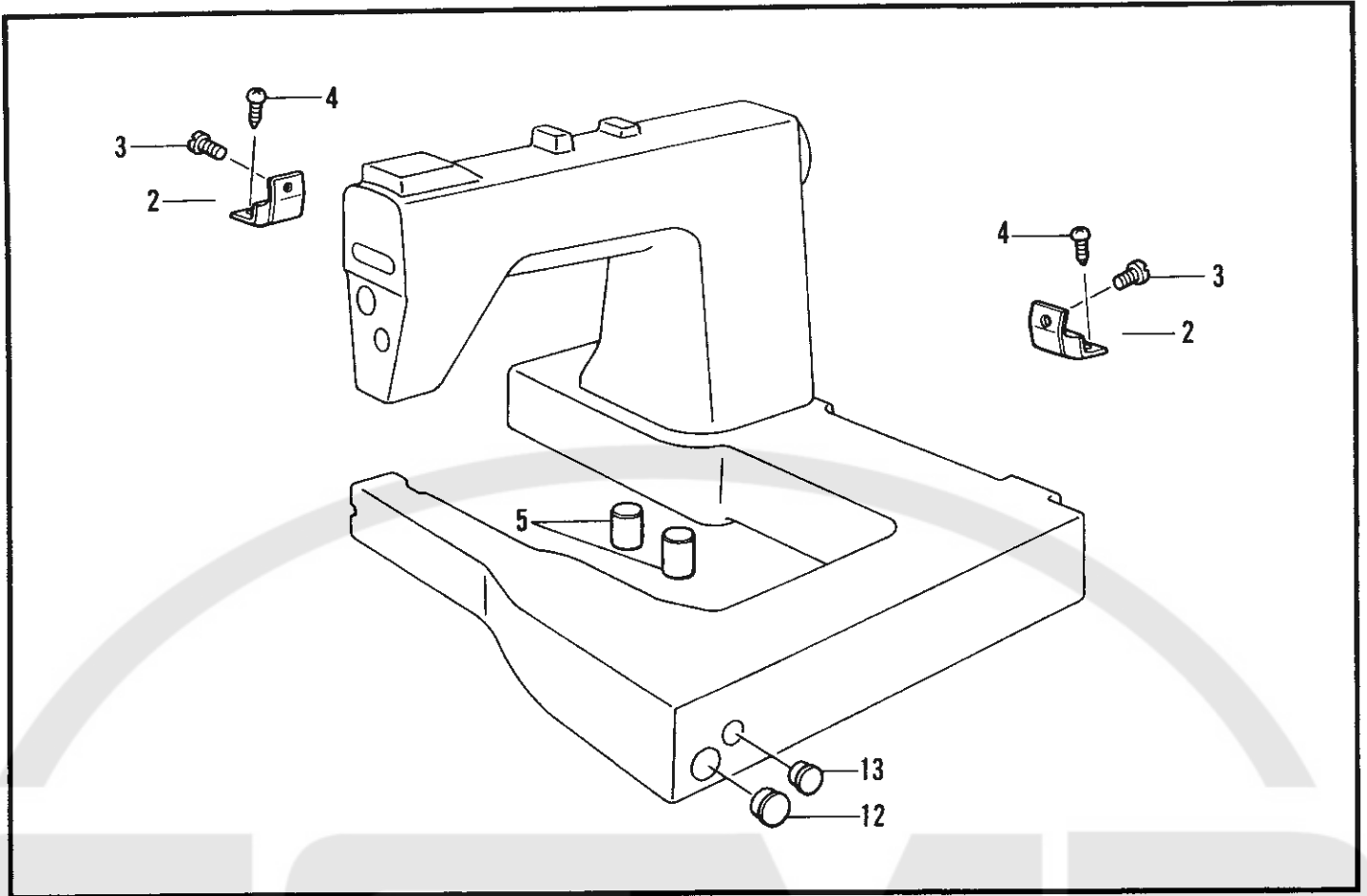

B. 上軸關係 / Upper shaft mechanism / Obere Welle / Mécanisme de l'arbre supérieur / Mecanismo del eje superior

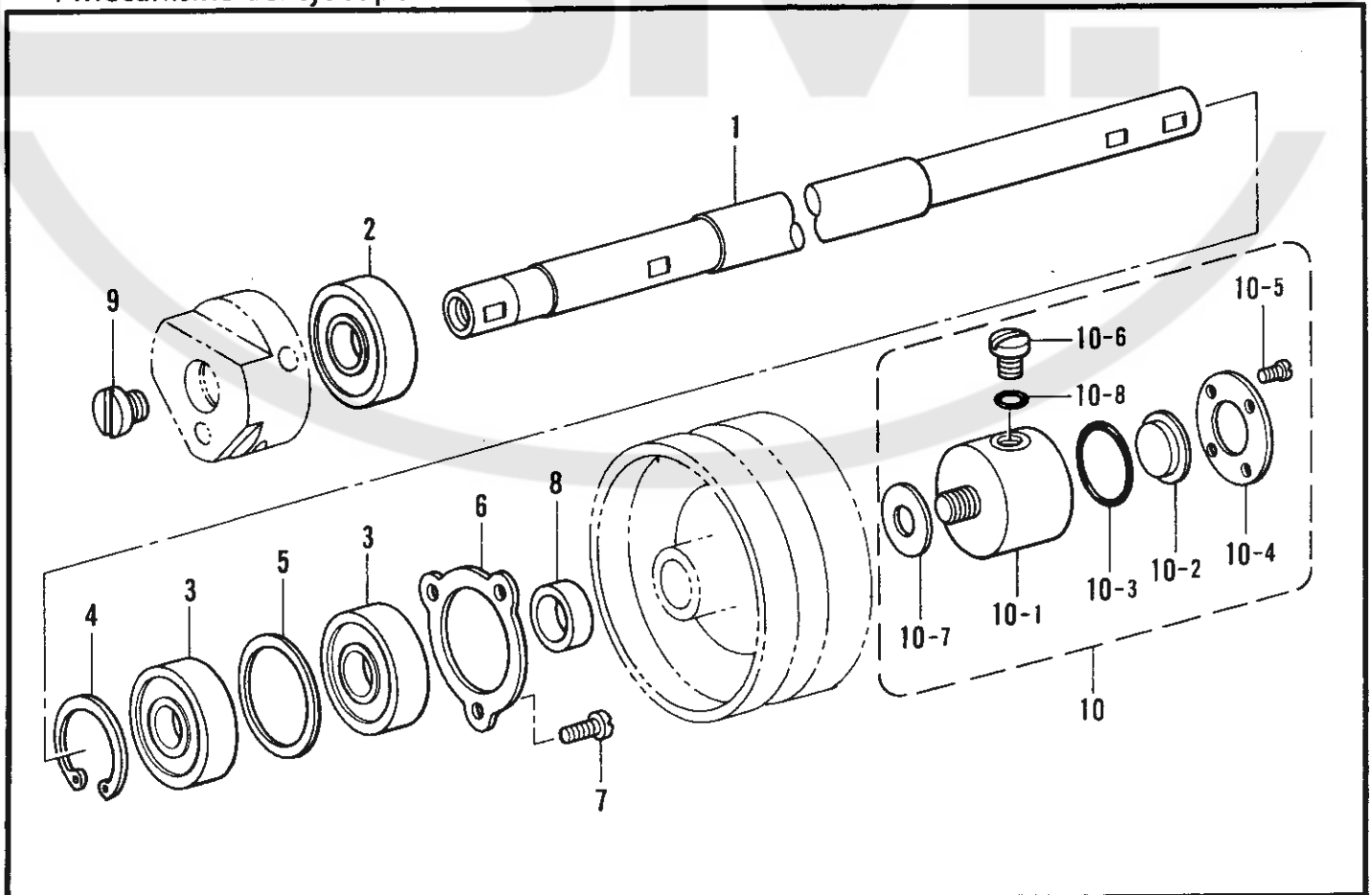

主体関係 / Machine body / Maschinengehäuse / Corps de la machine / Cuerpo de la máquina

REF.NO.	CODE	Q'TY	ヒンメイ	NAME OF PARTS	RM
2	105337001	2	クツシヨンクミ	CUSHION ASSY	
3	105146001	2	シメネジ6.35	SCREW, SM6.35	
4	0B0622502	2	+マルモク62X25	WOOD SCREW, ROUND M6.2X25	
5	105341051	2	ボウクツシヨン	BASE CUSHION	
12	150697001	1	オイルボツトマド	OIL GAUGE WINDOW	
13	104449009	1	ゴムセン15.5	RUBBER CAP, 15.5	

B. 上軸関係 / Upper shaft mechanism / Obere Welle / Mécanisme de l'arbre supérieur
/ Mecanismo del eje superior

REF.NO.	CODE	Q'TY	ヒンメイ	NAME OF PARTS	RM
1	S40314001	1	ウワジク	UPPER SHAFT	
2	076302850	1	タマジクウケ6302ZZ	BALL BEARING, 6302ZZ	
3	072630260	2	ベアリング6302VV	BALL BEARING, 6302VV	
4	048420242	1	トメワアナヨウC42	RETAINING RING, C42	
5	S40315051	1	ベアリングスペーサ	BEARING SPACER	
6	S40316051	1	ベアリングオサエ	BEARING PRESSER	
7	062711012	3	ナベコ476-32X10	SCREW, PAN SM4.76-32X10	
8	S40318051	1	ウワジクカラー	UPPER SHAFT COLLAR	
9	S40317001	1	シメネジ9.52	SCREW, SM9.52	
10	S40812001	1	オイルタンククミ	OIL TANK ASSY	
10-1	S40383001	1	オイルタンク	OIL TANK	
10-2	104547001	1	ユリヨウケイマド	OIL GAUGE WINDOW	
10-3	081014670	1	OリングPW14	O RING, PW14	
10-4	151074009	1	ユリヨウケイフタ	OIL GAUGE COVER	
10-5	100257010	4	シメネジ3.57	SCREW, SM3.57	
10-6	111193001	1	オイルクチフタ	OIL FEEDING PIPE CAP	
10-7	105071001	1	オイルタンクパツキン	OIL TANK PACKING	
10-8	111194001	1	Oリング	O RING	

針棒関係 / Needle bar mechanism / Nadelstangenvorrichtung
 / Mécanisme de la barre à aiguille / Mecanismo de la barra de aguja

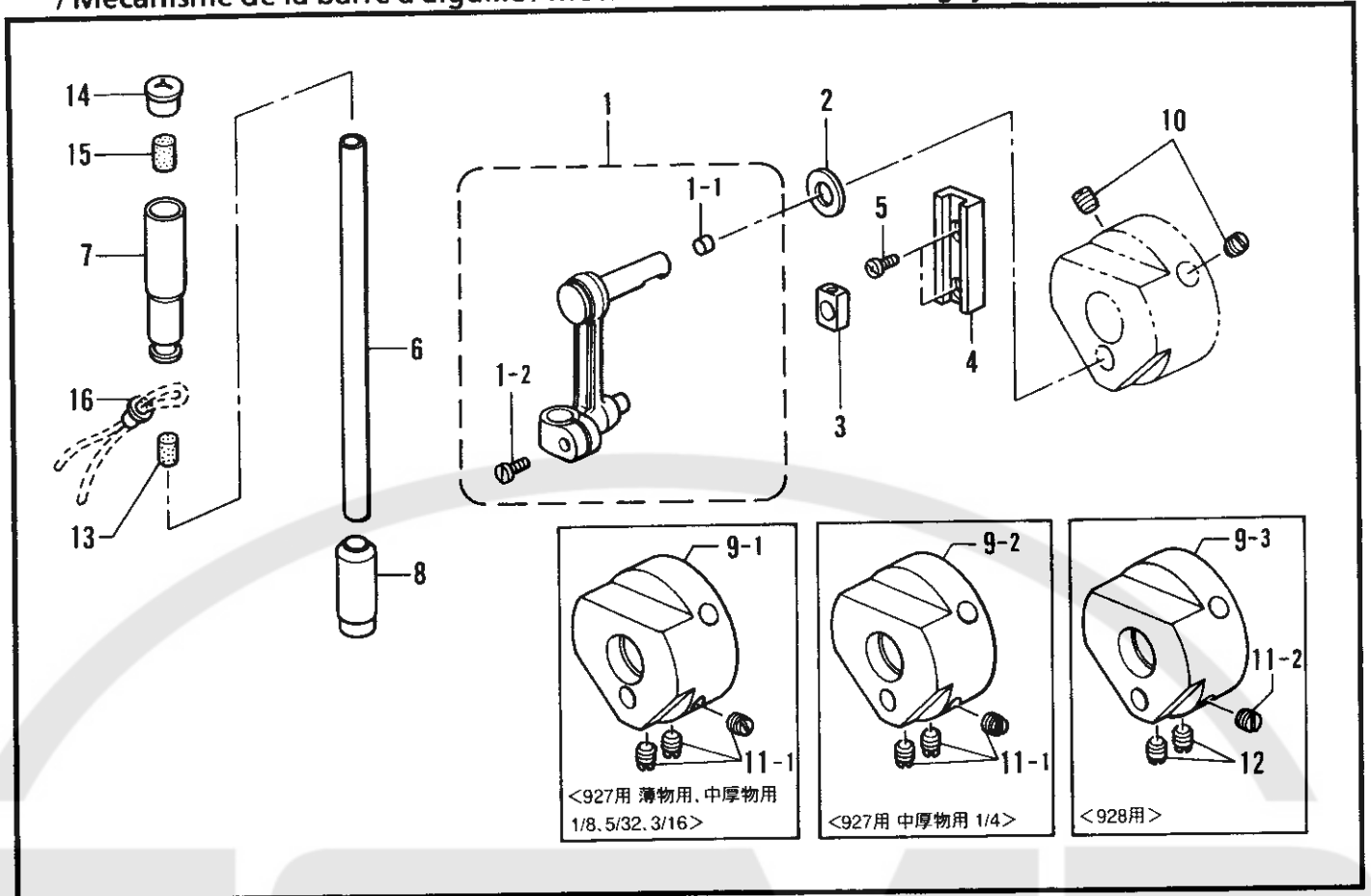

D1. 押工棒関係 (927) / Presser bar mechanism (927) / Stoffdrückerstange (927)
 / Mécanisme du la barra de presser (927) / Mecanismo de la barra del prensatelas (927)

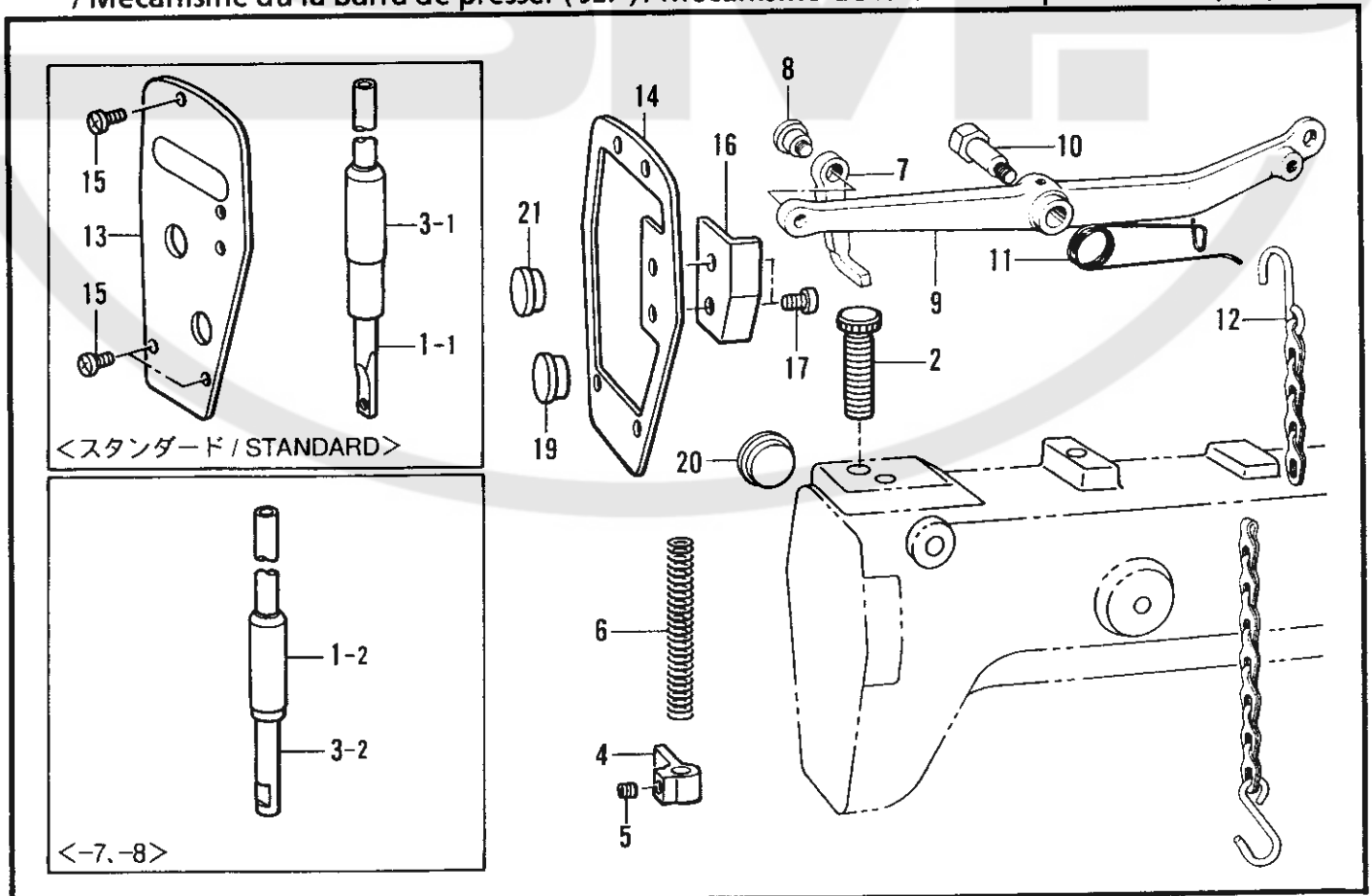

C. 針棒関係 / Needle bar mechanism / Nadelstangenvorrichtung
/ Mécanisme de la barre à aiguille / Mecanismo de la barra de aguja

REF.NO.	CODE	Q'TY	ヒンメイ	NAME OF PARTS	RM
1	S40268001	1	ハリボウレンカンクミ	THREAD TAKE-UP LEVER ASSY	
1-1	142274009	1	ゴムセン4.2	RUBBER CAP, 4.2	
1-2	140004001	1	シメネジ3.57	SCREW, SM3.57	
2	107153001	1	ザガネ	WASHER	
3	102630001	1	ハリボウアンナイカクコマ	NEEDLE BAR GUIDE SLIDE BLOCK	
4	145688000	1	ハリボウアンナイ	NEEDLE BAR GUIDE	
5	062670612	2	ナベコ357-40X6	SCREW, PAN SM3.57-40X6	
6	113605051	1	ハリボウ	NEEDLE BAR	
7	S18874001	1	ハリボウメタルU	NEEDLE BAR BUSH, U	
8	111024101	1	ハリボウメタルD	NEEDLE BAR BUSH, D	
10	014771022	2	アナトメネジ6.35クボミ	SET SCREW, SOCKET (CP) SM6.35	
13	111863001	1	ハリボウセン	NEEDLE BAR CORK	
14	140890009	1	オイルカット	OIL CAP	
15	151927001	1	クラツチフェルト	CLUTCH FELT	
16	109993001	1	ハトメ	WICK NIPPER	
9-1	S40271051	1	<927薄物・中厚物用 1/8, 5/32, 3/16 > テンピンクランクM	<For 927 Thin & Medium materials "1/8, 5/32, 3/16" > THREAD TAKE-UP CRANK, M	
11-1	100251001	3	トメネジ6.35	SET SCREW, SM6.35	
9-2	S40272051	1	<927 中厚物用 1/4 > テンピンクランクMH	<For 927 Medium materials "1/4" > THREAD TAKE-UP CRANK, MH	
11-1	100251001	3	トメネジ6.35	SET SCREW, SM6.35	
9-3	S40273051	1	<928用 > テンピンクランクH	<FOR 928 > THREAD TAKE-UP CRANK, H	
11-2	100251001	1	トメネジ6.35	SET SCREW, SM6.35	
12	123006001	2	トメネジ6.35クボミ	SET SCREW, (CP) SM6.35	

D1. 押工棒関係 (927) / Presser bar mechanism (927) / Stoffdrückerstange (927)
/ Mécanisme de la barra de presser (927) / Mecanismo de la barra del prensatelas (927)

REF.NO.	CODE	Q'TY	ヒンメイ	NAME OF PARTS	RM
2	S40299001	1	オサエチヨウセツネジ	ADJUST SCREW	
4	S40798050	1	オサエボウダキ	PRESSER BAR CLAMP	
5	014760622	1	アナトメネジ5.95	SET SCREW, SOCKET SM5.95	
6	S40298051	1	オサエバネ	SPRING	
7	105103001	1	オサエボウアゲ	PRESSER BAR LIFTER	
8	105104001	1	ダンネジ5.95	SHOULDER SCREW, SM5.95	
9	105105009	1	ヒザアゲテコ	KNEE LIFTER LEVER	
10	102921002	1	ダンネジ7.94	SHOULDER SCREW, SM7.94	
11	105106001	1	ヒザアゲネジリバネ	TWIST SPRING	
12	105333001	1	クサリアクミ	PRESSER FOOT LIFTER CHAIN ASSY	
14	S40301001	1	メンイタハツキン	PACKING	
16	S40279001	1	ソクメンイタ	FRONT LID	
17	062680512	2	ナベコ437-40X5	SCREW, PAN SM4.37-40X5	
19	117934009	1	ゴムセン13.5	RUBBER CAP, 13.5	
20	159150009	1	ゴムセン20.5	RUBBER CAP, 20.5	
21	159150009	1	ゴムセン20.5	RUBBER CAP, 20.5	
1-1	S06259001	1	<スタンダード用 > オサエボウ	<FOR STANDARD > PRESSER BAR	
3-1	111025001	1	オサエボウメタルD	PRESSER BAR BUSH, D	
13	S40300001	1	メンイタ	FACE PLATE	
15	062681012	3	ナベコ437-40X10	SCREW, PAN SM4.37-40X10	
1-2	S06261001	1	<-7, -8用 > オサエボウ	<FOR "-7, -8" > PRESSER BAR	
3-2	150665001	1	オサエボウメタルD	PRESSER BAR BUSH, D	

押工棒関係 (928) / Presser bar mechanism (928) / Stoffdrückérstange (928)
 / Mécanisme du la barra de presser (928) / Mecanismo de la barra del prensatelas (928)

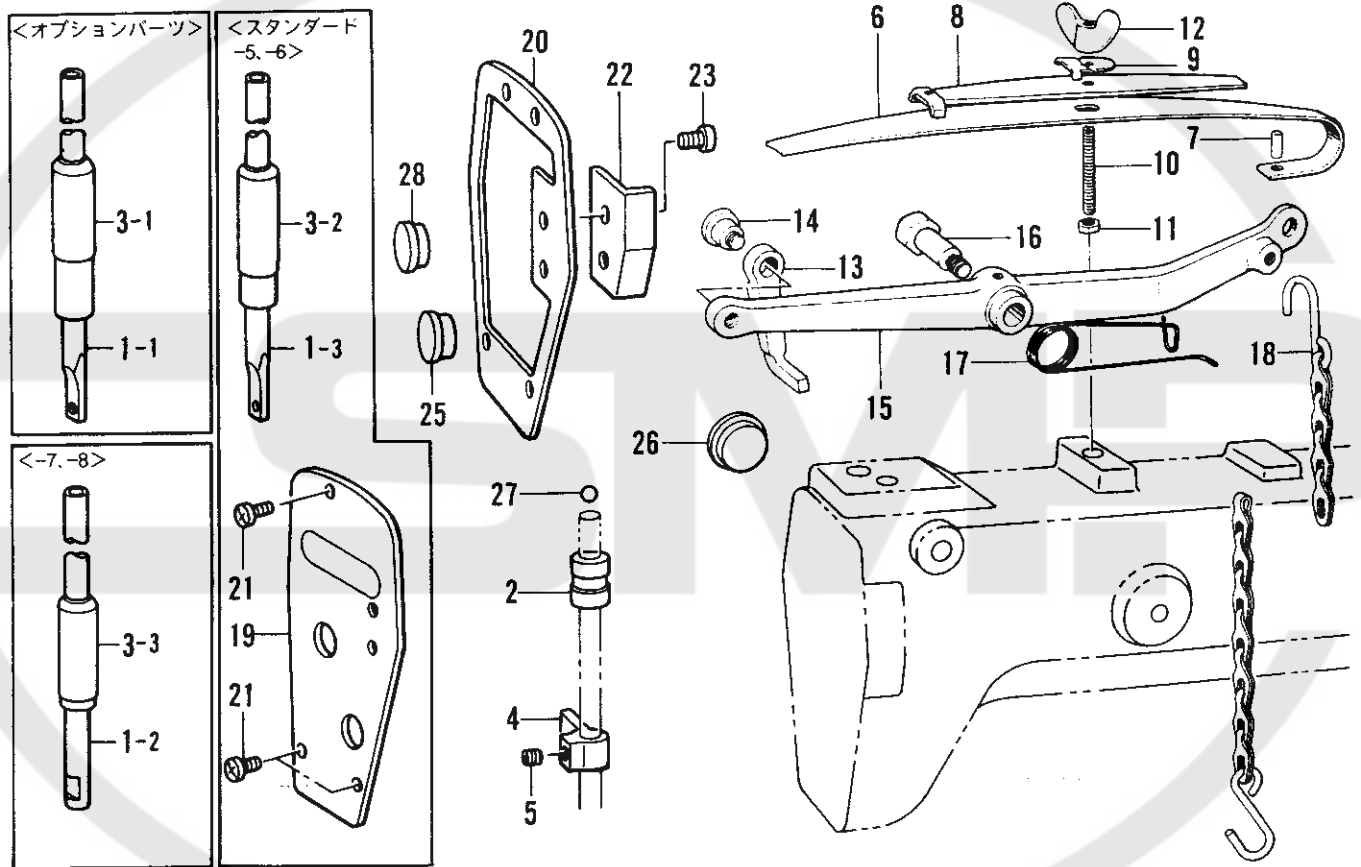

押工棒関係 (928) / Presser bar mechanism (928) / Stoffdrückerstange (928)
 / Mécanisme du la barra de presser (928) / Mecanismo de la barra del prensatelas (928)

REF.NO.	CODE	Q'TY	ヒンメイ	NAME OF PARTS	RM
2	105091001	1	オサエボウメタルU	PRESSER BAR BUSH, U	
4	S40798050	1	オサエボウダキ	PRESSER BAR CLAMP	
5	014760622	1	アナトメネジ5.95	SET SCREW, SOCKET SM5.95	
6	105094009	1	オサエイタバネ	PRESSER PLATE SPRING	
7	105095001	1	オサエイタバネピン	PIN	
8	105096009	1	カサネイタバネクミ	PLATE SPRING ASSY	
9	105100001	1	カサネイタバネトメザガネ	WASHER	
10	148006001	1	オサエチヨウセツネジ	ADJUST SCREW	
11	021710212	1	ナツト2シユ4.76	NUT, 2 SM4.76	
12	148007051	1	チヨウナツト4.76	WING NUT, SM4.76	
13	105103001	1	オサエボウアゲ	PRESSER BAR LIFTER	
14	105104001	1	ダンネジ5.95	SHOULDER SCREW, SM5.95	
15	105105009	1	ヒザアゲテコ	KNEE LIFTER LEVER	
16	102921002	1	ダンネジ7.94	SHOULDER SCREW, SM7.94	
17	105106001	1	ヒザアゲネジリバネ	TWIST SPRING	
18	105333001	1	クサリアクミ	PRESSER FOOT LIFTER CHAIN ASSY	
20	S40301001	1	メンイタバツキン	PACKING	
22	S40279001	1	ソクメンイタ	FRONT LID	
23	062680512	2	ナベコ437-40X5	SCREW, PAN SM4.37-40X5	
25	117934009	1	ゴムセン13.5	RUBBER CAP, 13.5	
26	159150009	1	ゴムセン20.5	RUBBER CAP, 20.5	
27	071063550	1	コウキユウ1/4	BEARING BALL, 1/4	
28	159150009	1	ゴムセン20.5	RUBBER CAP, 20.5	
1-3	S06260001	1	<スタンダード,-5,-6用> オサエボウ	<FOR STANDARD, -5 & -6> PRESSER BAR	
3-2	147865001	1	オサエボウメタルD	PRESSER BAR BUSH, D	
19	S40300001	1	メンイタ	FACE PLATE	
21	062681012	3	ナベコ437-40X10	SCREW, PAN SM4.37-40X10	
1-2	S06261001	1	<-7,-8用> オサエボウ	<FOR "-7,-8"> PRESSER BAR	
3-3	150665001	1	オサエボウメタルD	PRESSER BAR BUSH, D	
1-1	S06259001	1	" オプション部品 " オサエボウ	" OPTION PARTS " PRESSER BAR	
3-1	111025001	1	オサエボウメタルD	PRESSER BAR BUSH, D	

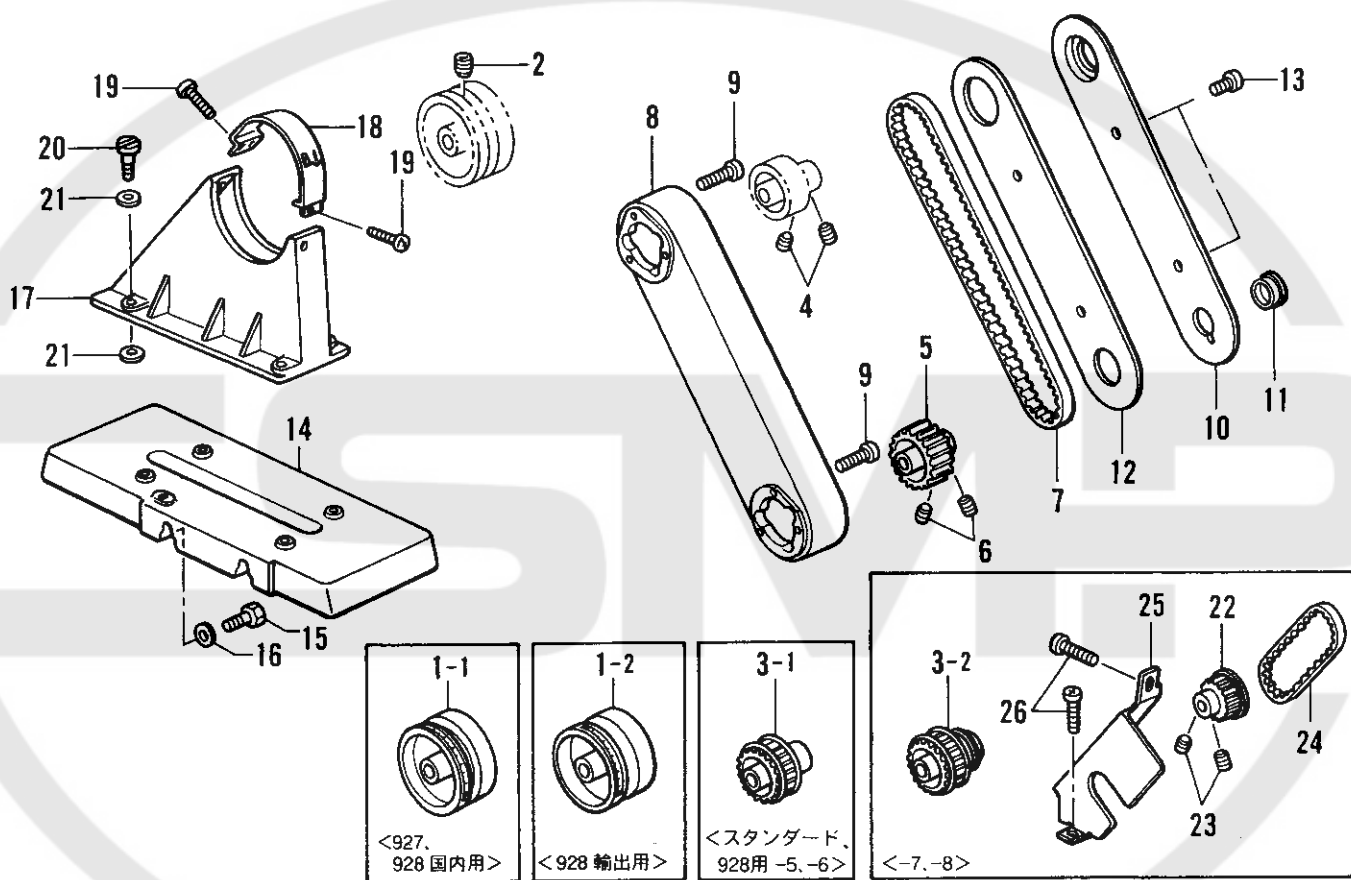

プーリ関係 / Pulley mechanism / Gürtelradmechanismus / Poulie / Polea

REF.NO.	CODE	Q'TY	ヒンメイ	NAME OF PARTS	RM
2	014781032	2	アナクボミ 635-28X10	SET SCREW, SOCKET (CP) SM6.35	
4	014770622	2	アナトメネジ6.35クボミ	SET SCREW, SOCKET (CP) SM6.35	
5	S40818001	1	シタベルトクルマ	TIMING BELT WHEEL ASSY, LOWER	
6	014770622	2	アナトメネジ6.35クボミ	SET SCREW, SOCKET (CP) SM6.35	
7	S40819000	1	タイミングベルト	TIMING BELT	
8	S40258001	1	ベルトカバー	BELT COVER	
9	062711612	6	ナベコ476-32X16	SCREW, PAN SM4.76-32X16	
10	S40259001	1	ベルトカバーフタ	BELT COVER PLATE	
11	116577051	1	カマジクフタ	ROTARY HOOK SHAFT COVER	
12	105141001	1	ベルトカバーフタパツキン	PACKING	
13	062710812	2	ナベコ476-32X8	SCREW, PAN SM4.76-32X8	
14	S40796001	1	プーリカバーダイ	PULLEY COVER BASE	
15	105144001	2	ボルト11.11	BOLT, SM11.11	
16	142627001	2	ザガネ	WASHER	
17	S40261001	1	プーリカバー-A	PULLEY COVER, A	
18	S40262001	1	プーリカバー-B	PULLEY COVER, B	
19	062680712	3	ナベコ437-40X7	SCREW, PAN SM4.37-40X7	
20	155558001	4	ダンネジ6.35	STUD SCREW, SM6.35	
21	S40797000	8	プーリカバーシート	PULLEY COVER SHEET...	
1-1	S40280001	1	< 927用, 928国内用 > プーリMクミ	< FOR 927 & 928 Japan > PULLEY ASSY, M	
1-2	S40281001	1	< 928輸出用 > プーリHクミ	< FOR 928 EXPORT > PULLEY ASSY, H	
3-1	S40265001	1	< スタンダード, 928-5, -6用 > ウエベルトクルマクミ	< FOR STANDARD, 928-5 & -6 > TIMING BELT WHEEL ASSY, UPPER	
3-2	S41312001	1	< -7, -8用 > プーラウエベルトクルマクミ	< FOR "-7, -8" > PULLER TIMING BELT WH. ASSY, U	
22	150659001	1	タイミングプーリBクミ	TIMING PULLEY ASSY, B	
23	014760622	2	アナトメネジ5.95	SET SCREW, SOCKET SM5.95	
24	150661001	1	プーラタイミングベルトA	PULLER TIMING BELT, A	
25	S40264001	1	プーラベルトカバー	PULLEY BELT COVER	
26	062680812	2	ナベコ437-40X8	SCREW, PAN SM4.37-40X8	

送り関係 / Feed mechanism / Transportvorrichtung / Mécanisme de l'entraînement
 / Mecanismo de la alimentación

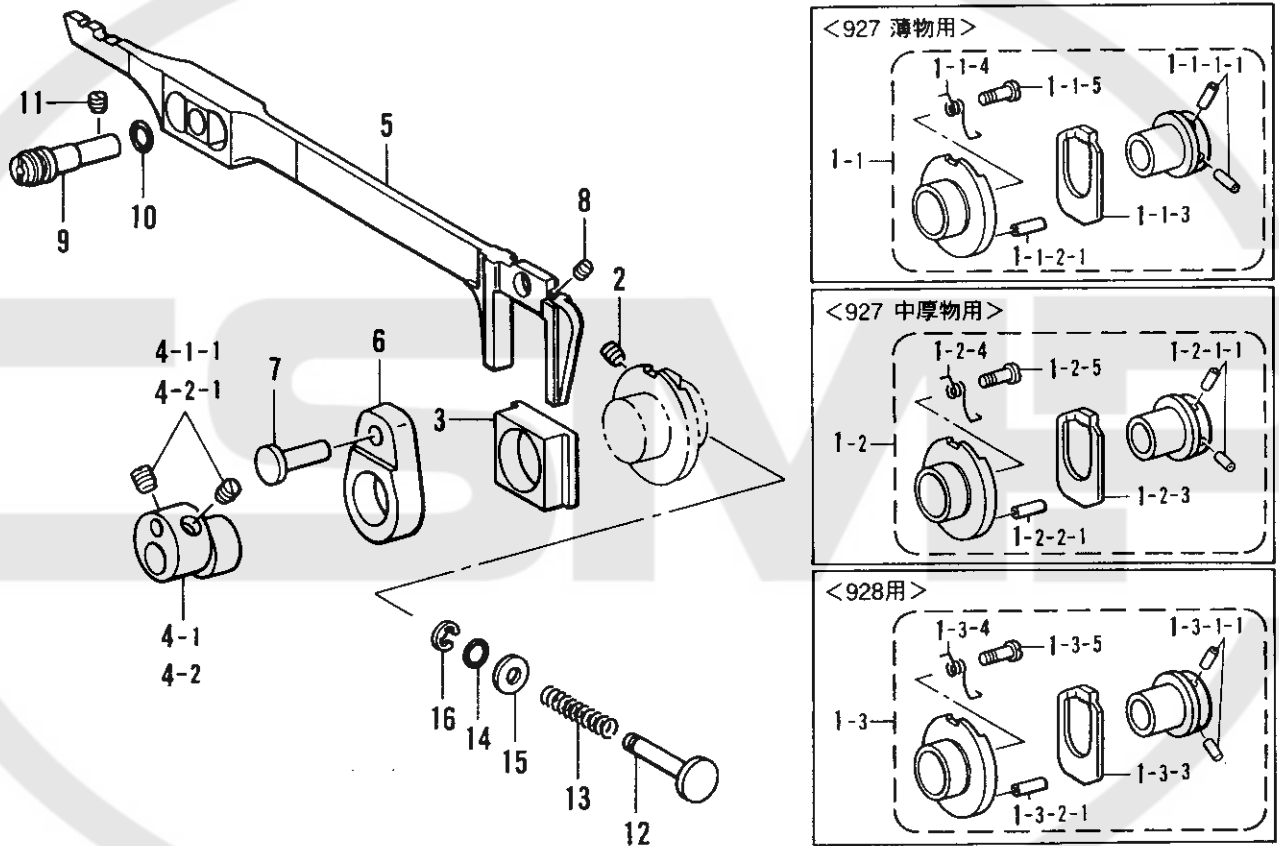

送り関係 / Feed mechanism / Transportvorrichtung / Mécanisme de l'entraînement /
Mecanismo de la alimentación

REF.NO.	CODE	Q'TY	ヒンメイ	NAME OF PARTS	RM
1-1	S40274001	1	<927薄物用> ヘンシンリンクミM	<FOR 927 "THIN MATERIALS"> ECCENTRIC WHEEL ASSY, M	
1-1-1-1	047301242	2	スプリングピンAW3	PIN, SPRING AW3	
1-1-2-1	047301242	1	スプリングピンAW3	PIN, SPRING AW3	
1-1-3	S38309001	1	ラチエットストツバ	RACHTER STOPPER	
1-1-4	S39585001	1	ラチエットトメネジリバネ	TWIST SPRING	
1-1-5	S39586001	1	バネトメネジ3	SCREW, M3	
1-2	S40274002	1	<927中厚物用> ヘンシンリンクミM	<FOR 927 "MEDIUM MATERIALS"> ECCENTRIC WHEEL ASSY, M	
1-2-1-1	047301242	2	スプリングピンAW3	PIN, SPRING AW3	
1-2-2-1	047301242	1	スプリングピンAW3	PIN, SPRING AW3	
1-2-3	S38309001	1	ラチエットストツバ	RACHTER STOPPER	
1-2-4	S39585001	1	ラチエットトメネジリバネ	TWIST SPRING	
1-2-5	S39586001	1	バネトメネジ3	SCREW, M3	
1-3	S40291001	1	<928用> ヘンシンリンクミH	<FOR 928> ECCENTRIC WHEEL ASSY, H	
1-3-1-1	047301242	2	スプリングピンAW3	PIN, SPRING AW3	
1-3-2-1	047301242	1	スプリングピンAW3	PIN, SPRING AW3	
1-3-3	S38309001	1	ラチエットストツバ	RACHTER STOPPER	
1-3-4	S39585001	1	ラチエットトメネジリバネ	TWIST SPRING	
1-3-5	S39586001	1	バネトメネジ3	SCREW, M3	
4-1	183949001	1	<927用> ヘンシンリンネジツキM	<FOR 927> ECCENTRIC WHEEL WITH SCREW, M	
4-1-1	014770622	2	アナトメネジ6.35クボミ	SET SCREW, SOCKET (CP) SM6.35	
4-2	183950001	1	<928用> ヘンシンリンネジツキH	<FOR 928> ECCENTRIC WHEEL WITH SCREW, H	
4-2-1	014770622	2	アナトメネジ6.35クボミ	SET SCREW, SOCKET (CP) SM6.35	
2	012060632	2	アナヒラ6X6	SET SCREW, SOCKET (FT) M6X6	
3	S40282000	1	ヘンシンリンスリーブ	ECCENTRIC WHEEL SLEEVE	
5	S40285001	1	オクリダイカクコマクミ	FEED BAR SLIDE BLOCK ASSY	
6	S40288000	1	ジヨウゲオクリレンカン	FEED LIFTING CONNECTING SHAFT	
7	S40289051	1	ジヨウゲオクリジク	FEED LIFTING ROCK SHAFT	
8	014760622	1	アナトメネジ5.95	SET SCREW, SOCKET SM5.95	
9	S41311051	1	オクリダイヘンシンジク	FEED BAR ECCENTRIC SHAFT	
10	081006070	1	OリングP6	O RING, P6	
11	014761030	1	アナクボミ595-28X10	SET SCREW, SOCKET (CP) SM5.95	
12	S40290051	1	プツシュボタン	PUSH BUTTON	
13	S40800001	1	ボタンジクバネ	SPRING	
14	081005070	1	OリングP5	O RING, P5	
15	025710132	1	ヒラザガネシヨウ4.76	WASHER, PLAIN S 4.76	
16	048040342	1	トメワE4	RETAINING RING, E4	

ゲージ関係 (927スタンダード) / Gauge parts (927 Standard) / Lehren (927 Norm)
 / Pièces du jauge (927 Standard) / Piezas de calibradores (927 Norma)

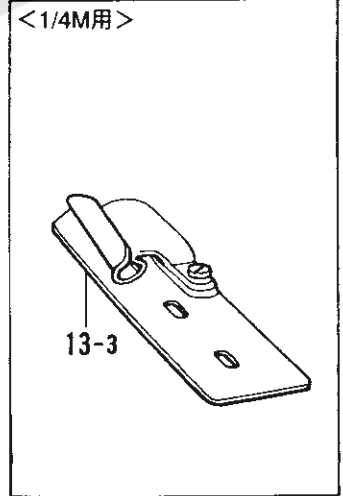
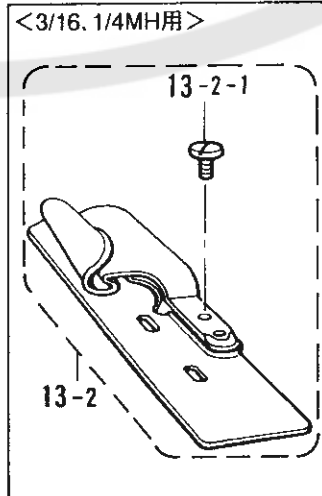
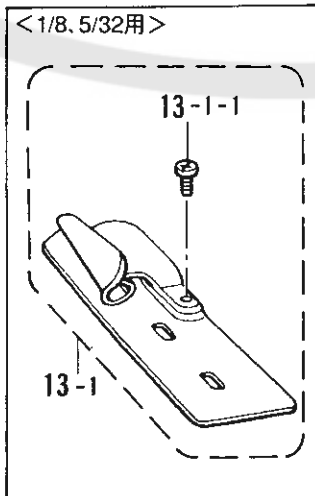
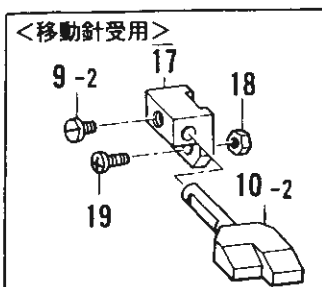
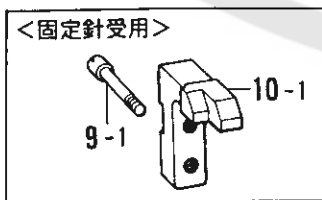
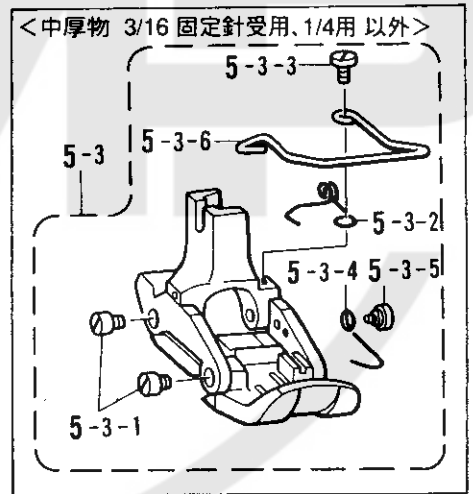
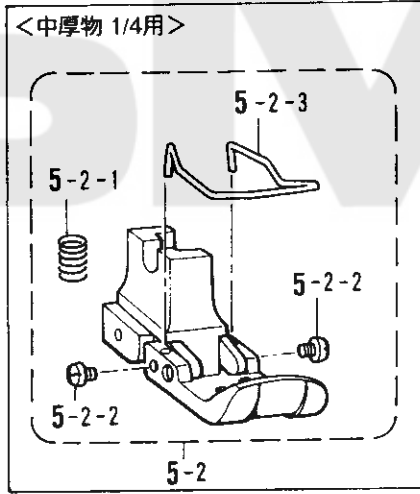
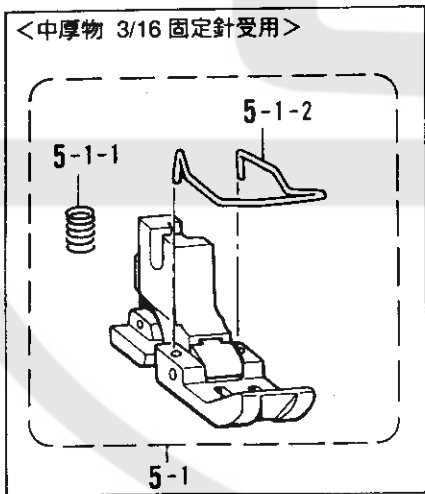
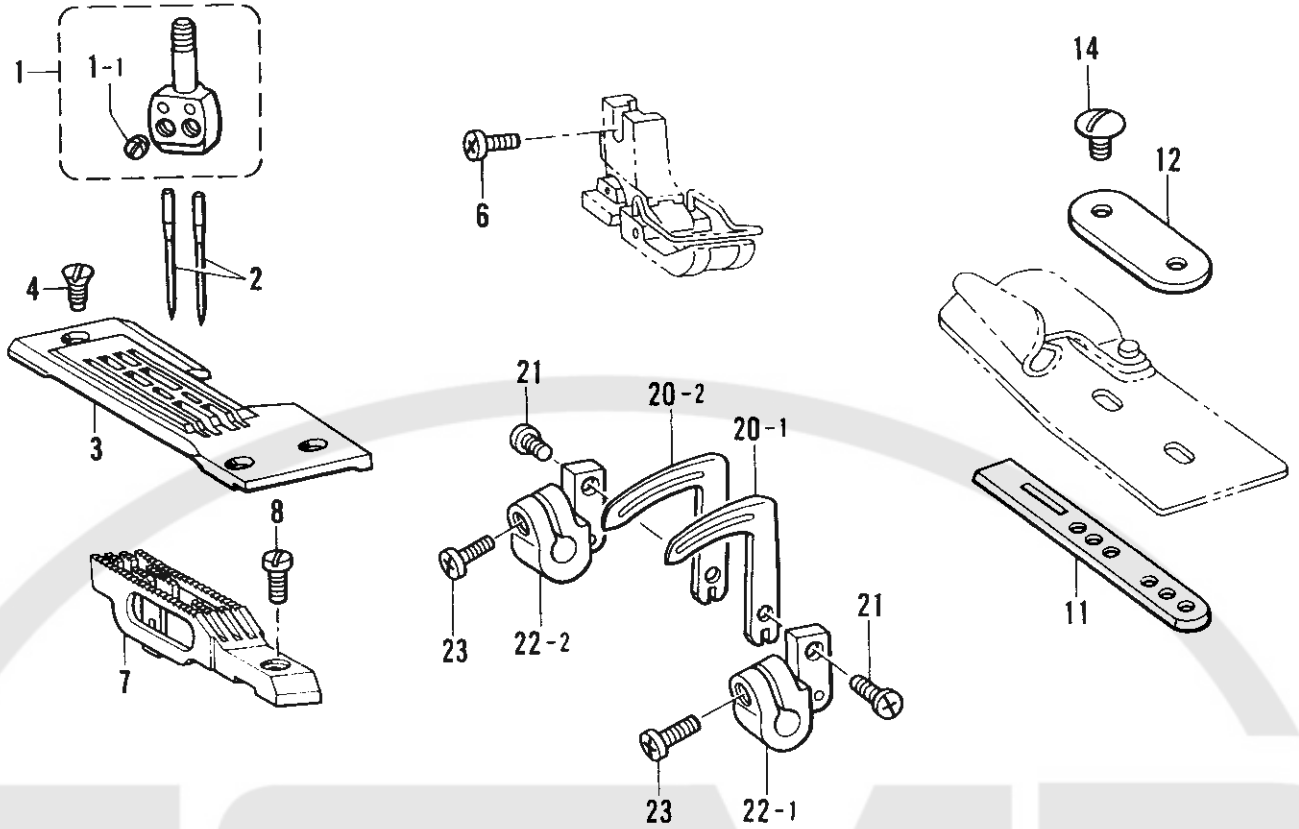

ゲージ関係 (927スタンダード) / Gauge parts (927 Standard) / Lehren (927 Norm)
 / Pièces du jauge (927 Standard) / Piezas de calibradores (927 Norma)

REF.NO.	CODE	Q'TY	ヒンメイ	NAME OF PARTS	RM
1	※	1	ハリダキネジツキ	NEEDLE CALMP ASSY W/S	
1-1	103408002	2	トメネジ4.37	SET SCREW, SM4.37	
2	※	2	ミシンハリ	NEEDLE	
3	※	1	ハリイタ	NEEDLE PLATE	
4	100032004	3	サラネジ4.37	SCREW, FLAT SM4.37	
6	060670812	1	バインド357-40X8	SCREW, BIND SM3.57-40X8	
7	※	1	オクリバ	FEED DOG	
8	105173004	1	シメネジ4.76	SCREW, SM4.76	
11	S40399001	1	ラツパーアンナイイタ	LAPPER GUIDE PLATE	
12	105129001	1	アンナイイタザガネ	LAPPER GUIDE PLATE WASHER	
14	105130001	2	シメネジ3.57	SCREW, SM3.57	
20-1	※	1	ルーパス	LOPPER, S	
20-2	※	1	ルーパL	LOPPER, L	
21	062680612	2	ナベコ4.37-40X6	SCREW, PAN SM4.37-40X6	
22-1	S06315001	1	ルーパホルダS	LOOPER HOLDER, S	
22-2	S06314001	1	ルーパホルダL	LOOPER HOLDER, L	
23	062681012	2	ナベコ437-40X10	SCREW, PAN SM4.37-40X10	

5-1	101491101	1	<中厚物3/16固定針受用> オサエ3/16クミ	<For medium materials 3/16" Fix needle support"> PRESSER FOOT ASSY, 3/16"	
5-1-1	105118000	1	オシバネ	SPRING	
5-1-2	156792001	1	フィンガーガード	FINGER GUARD	
5-2	106160101	1	<中厚物1/4用> オサエ1/4Hクミ	<For medium materials 1/4"> PRESSER FOOT ASSY, 1/4" H	
5-2-1	105118000	1	オシバネ	SPRING	
5-2-2	111140001	2	シメネジ2.38	SCREW, SM2.38	
5-2-3	156792001	1	フィンガーガード	FINGER GUARD	
5-3	※	1	<中厚物3/16固定針受, 1/4以外用> オサエクミ	<For without medium materials 3/16, 1/4"> PRESSER FOOT ASSY	
5-3-1	147871001	4	オサエピン	PIN	
5-3-2	S40358001	1	オサエMバネ	SPRING	
5-3-3	111105002	1	シメネジ2.38	SCREW, SM2.38	
5-3-4	S40360001	1	オサエFバネ	SPRING	
5-3-5	147932001	1	ダンネジ2.38	SHOULDER SCREW, SM2.38	
5-3-6	S40374001	1	フィンガーガード	FINGER GUARD	

9-1	105303001	1	<固定針受用> シメネジ3.57	<FOR FIXED NEEDLE GUARD> SCREW, SM3.57	
10-1	※	1	ルーバイトアンナイウデ	LOOPER THREAD GUIDE ARM	
9-2	111443003	1	<移動針受用> マルヒラトメネジ3.57	<FOR MOVEABLE NEEDLE GUARD> SET SCREW, SM3.57	
10-2	※	1	ハリウケ	NEEDLE GUARD	
17	148876001	1	ハリウケトリツケダイ	NEEDLE GUARD BRACKET	
18	021670102	1	ナツト1シユ3.57	NUT, 1 SM3.57	
19	062671012	1	ナベコ357-40X10	SCREW, PAN SM3.57-40X10	

13-1	※	1	<1/8, 5/32用> ラツパークミ	<FOR "1/8, 5/32"> LAPPER ASSY	
13-1-1	062670412	1	ナベコ357-40X4	SCREW, PAN SM3.57-40X4	
13-2	※	1	<3/16, 1/4MH用> ラツパークミ	<FOR "3/16, 1/4MH"> LAPPER ASSY	
13-2-1	105130001	1	シメネジ3.57	SCREW, SM3.57	
13-3	S09679001	1	<1/4M用> ラツパー1/4Mクミ	<FOR "1/4M"> LAPPER ASSY, 1/4" M	

ゲージ関係 (927) / Gauge parts (927) / Lehren (927)
 / Pièces du jauge (927) / Piezas de calibradores (927)

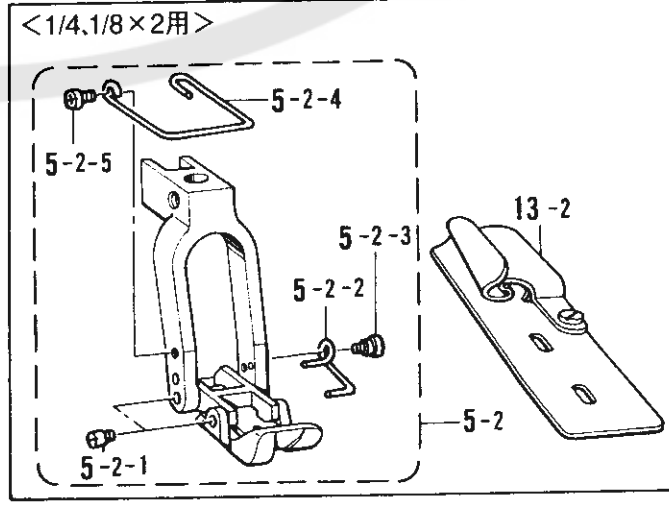
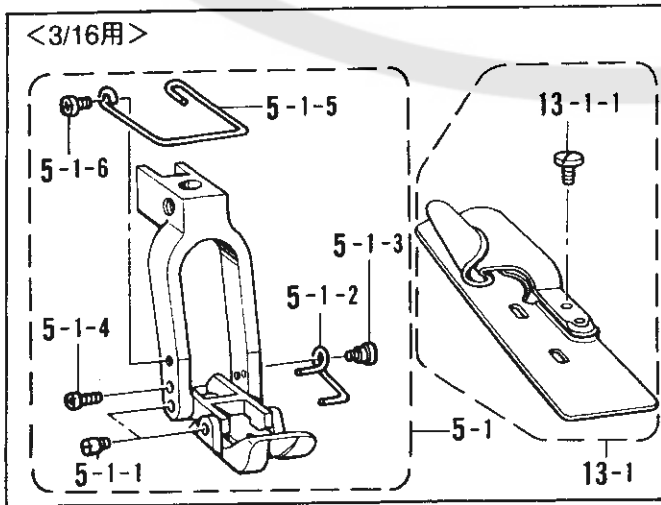
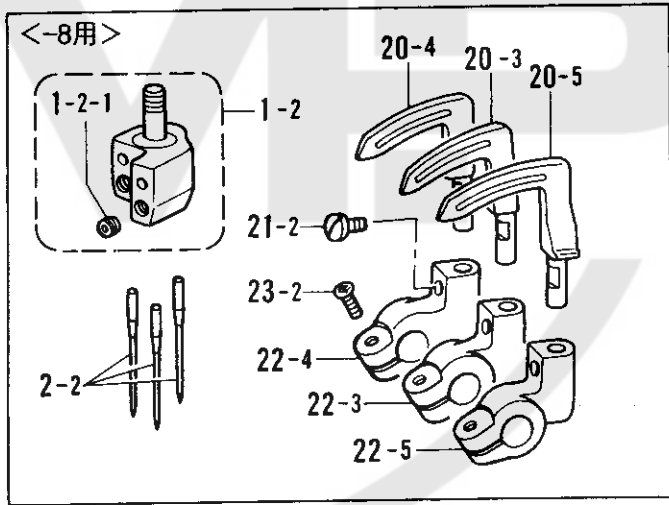
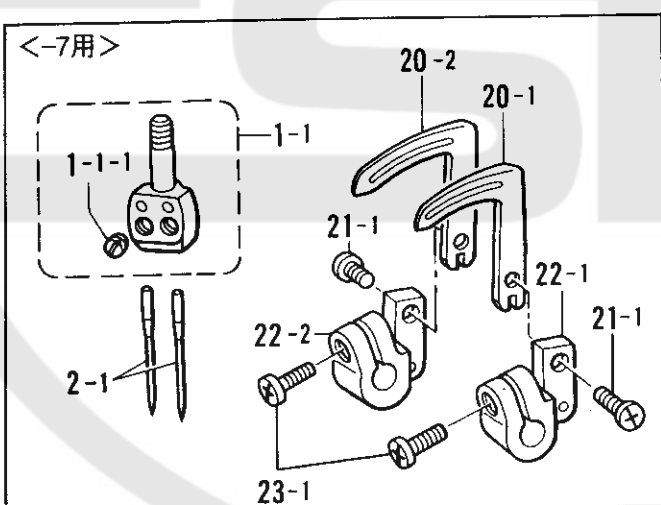
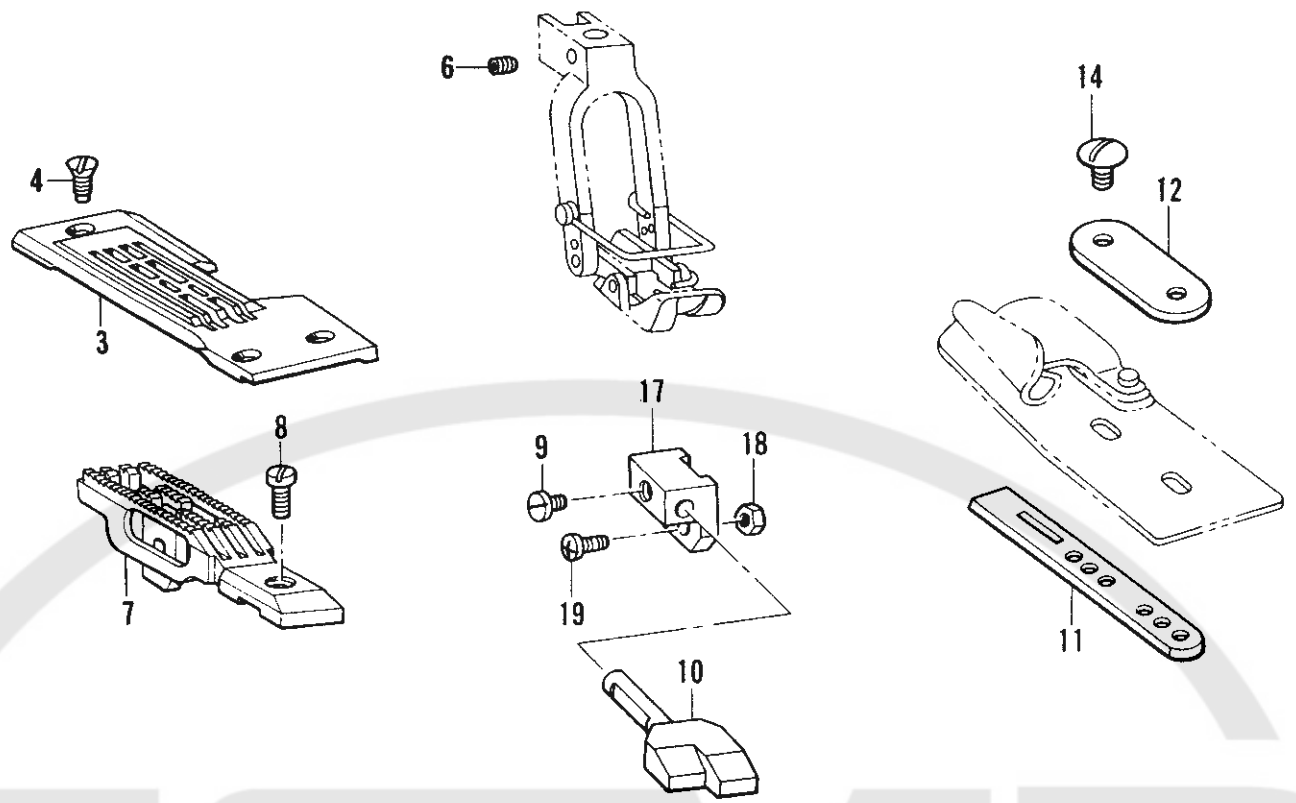

ゲージ関係(927) / Gauge parts (927) / Lehren (927)
 / Pièces du jauge (927) / Piezas de calibradores (927)

REF.NO.	CODE	Q'TY	ヒンメイ	NAME OF PARTS	RM
3	※	1	ハリイタ	NEEDLE PLATE	
4	100032004	3	サラネジ4.37	SCREW, FLAT SM4.37	
6	014760622	1	アナトメネジ5.95	SET SCREW, SOCKET SM5.95	
7	※	1	オクリバ	FEED DOG	
8	105173004	1	シメネジ4.76	SCREW, SM4.76	
9	111443003	1	マルヒラトメネジ3.57	SET SCREW, SM3.57	
10	※	1	ハリウケ	NEEDLE GUARD	
11	S40399001	1	ラツパーアンナイイタ	LAPPER GUIDE PLATE	
12	105129001	1	アンナイイタザガネ	LAPPER GUIDE PLATE WASHER	
14	105130001	2	シメネジ3.57	SCREW, SM3.57	
17	148876001	1	ハリウケトリツケダイ	NEEDLE GUARD BRACKET	
18	021670102	1	ナツト1シユ3.57	NUT, 1 SM3.57	
19	062671012	1	ナベコ357-40X10	SCREW, PAN SM3.57-40X10	

1-1	※	1	<-7用> ハリダキネジツキ	<FOR "-7"> NEEDLE CALMP ASSY W/S	
1-1-1	103408002	2	トメネジ4.37	SET SCREW, SM4.37	
2-1	※	2	ミシンハリTVX64NY	NEEDLE, TVX64NY	
20-1	※	1	ルーパス	LOPPER, S	
20-2	※	1	ルーパL	LOPPER, L	
21-1	062680612	2	ナベコ4.37-40X6	SCREW, PAN SM4.37-40X6	
22-1	S06315001	1	ルーパホルダS	LOOPER HOLDER, S	
22-2	S06314001	1	ルーパホルダL	LOOPER HOLDER, L	
23-1	062681012	2	ナベコ437-40X10	SCREW, PAN SM4.37-40X10	
1-2	※	1	<-8用> ハリダキネジツキ	<FOR "-8"> NEEDLE CLAMP ASSY W/S	
1-2-1	146427001	3	アナトメネジ3.18クボミ	SET SCREW, SOCKET (CP) SM3.18	
2-2	※	3	ミシンハリTVX64NY	NEEDLE, TVX64NY	
20-3	S40375001	1	ルーパス1/8X2-6	LOPPER, S 1/8"X2-6	
20-4	S40376001	1	ルーパM-6	LOPPER, M-6	
20-5	S40377001	1	ルーパL1/8X2-6	LOPPER, L 1/8"X2-6	
21-2	111443003	3	マルヒラトメネジ3.57	SET SCREW, SM3.57	
22-3	S40378051	1	ルーパホルダS	LOPPER HOLDER, S	
22-4	S40379051	1	ルーパホルダM	LOPPER HOLDER, M	
22-5	S40380051	1	ルーパホルダL	LOPPER HOLDER, L	
23-2	062671012	3	ナベコ357-40X10	SCREW, PAN SM3.57-40X10	

5-1	S06303101	1	<3/16用> オサエ3/16-7クミ	<FOR "3/16"> PRESSER FOOT ASSY, 3/16"-7	
5-1-1	147871001	4	オサエピン	PIN	
5-1-2	S06309001	1	オサエFバネ	SPRING	
5-1-3	147932001	1	ダンネジ2.38	SHOULDER SCREW, SM2.38	
5-1-4	062630612	1	ナベコ238-56X6	SCREW, PAN SM2.38-56X6	
5-1-5	S09180101	1	フィンガーガード	FINGER GUARD	
5-1-6	060660512	1	バインド318-40X5	SCREW, BIND SM3.18-40X5	
13-1	101494001	1	ラツパー3/16Mクミ	LAPPER ASSY, 3/16" M	
13-1-1	105130001	1	シメネジ3.57	SCREW, SM3.57	
5-2	※	1	<1/4, 1/8X2用> オサエクミ	<FOR "1/4, 1/8X2"> PRESSER FOOT ASSY	
5-2-1	147871001	4	オサエピン	PIN	
5-2-2	S06309001	1	オサエFバネ	SPRING	
5-2-3	147932001	1	ダンネジ2.38	SHOULDER SCREW, SM2.38	
5-2-4	S09180101	1	フィンガーガード	FINGER GUARD	
5-2-5	060660512	1	バインド318-40X5	SCREW, BIND SM3.18-40X5	
13-2	S09679001	1	ラツパー1/4Mクミ	LAPPER ASSY, 1/4" M	

ゲージ関係 (928 スタンダード) / Gauge parts (928 Standard) / Lehren (928 Norm)
 / Pièces du jauge (928 Standard) / Piezas de calibradores (928 Norma)

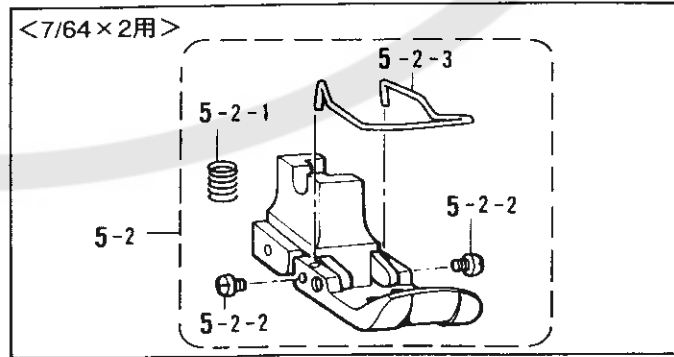
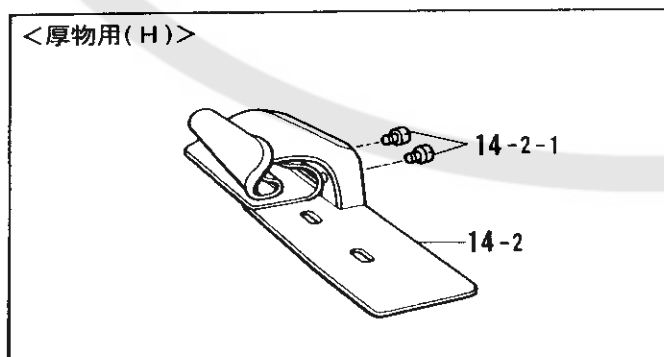
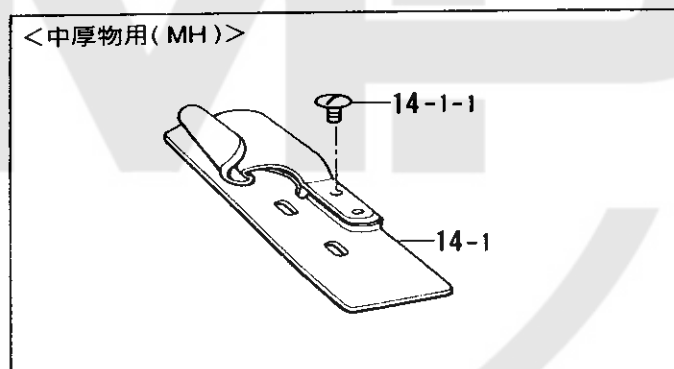
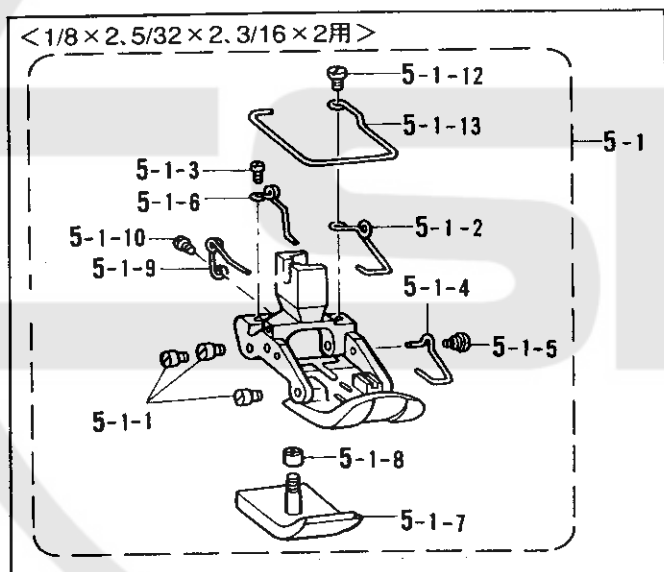
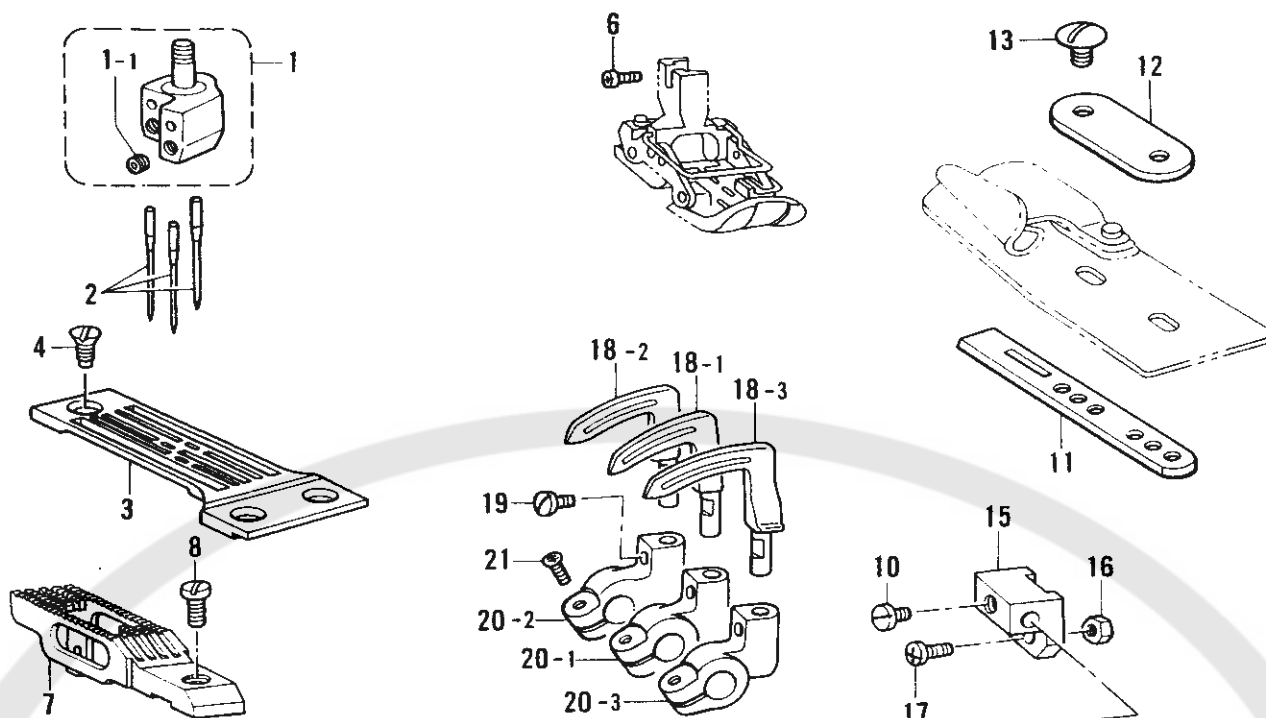

ゲージ関係 (928 スタンダード) / Gauge parts (928 Standard) / Lehren (928 Norm)
 / Pièces du jauge (928 Standard) / Piezas de calibradores (928 Norma)

REF.NO.	CODE	Q'TY	ヒンメイ	NAME OF PARTS	RM
1	※	1	ハリダクミ	NEEDLE CLAMP ASSY	
1-1	146427001	3	アナトメネジ3.18クボミ	SET SCREW, SOCKET (CP) SM3.18	
2	S43401021	3	ミシンハリTVX5	NEEDLE, TVX5 (#21)	
3	※	1	ハリイタ	NEEDLE PLATE	
4	100032004	3	サラネジ4.37	SCREW, FLAT SM4.37	
6	060670812	1	バインド357-40X8	SCREW, BIND SM3.57-40X8	
7	※	1	オクリバ	FEED DOG	
8	105173004	1	シメネジ4.76	SCREW, SM4.76	
9	148875001	1	ハリウケ-6	NEEDLE GUARD, -6	
10	111443003	1	マルヒラトメネジ3.57	SET SCREW, SM3.57	
11	S40399001	1	ラツパーアンナイイタ	LAPPER GUIDE PLATE	
12	105129001	1	アンナイイタザガネ	LAPPER GUIDE PLATE WASHER	
13	105130001	2	シメネジ3.57	SCREW, SM3.57	
15	148876001	1	ハリウケトリツケダイ	NEEDLE GUARD BRACKET	
16	021670102	1	ナツト1シユ3.57	NUT, 1 SM3.57	
17	062671012	1	ナベコ357-40X10	SCREW, PAN SM3.57-40X10	
18-1	※	1	ルーパス	LOPPER, S	
18-2	※	1	ルーパM	LOPPER, M	
18-3	※	1	ルーパL	LOPPER, L	
19	111443003	3	マルヒラトメネジ3.57	SET SCREW, SM3.57	
20-1	S40378051	1	ルーパホルダS	LOPPER HOLDER, S	
20-2	S40379051	1	ルーパホルダM	LOPPER HOLDER, M	
20-3	S40380051	1	ルーパホルダL	LOPPER HOLDER, L	
21	062671012	3	ナベコ357-40X10	SCREW, PAN SM3.57-40X10	
<1/8X2, 5/32X2, 3/16X2用>					
5-1	※	1	オサエクミ	PRESSER FOOT ASSY	
5-1-1	147871001	6	オサエピン	PIN	
5-1-2	147872001	1	オサエMバネ	SPRING	
5-1-3	S01295001	1	シメネジ2.38X3.5	SCREW, SM2.38X3.5	
5-1-4	147890001	1	オサエFバネ	SPRING	
5-1-5	147932001	1	ダンネジ2.38	SHOULDER SCREW, SM2.38	
5-1-6	147875001	1	オサエBLバネ	SPRING	
5-1-8	147877001	1	ツマミナツト3.18	NUT, SM3.18	
5-1-9	147878001	1	オサエBSバネ	SPRING	
5-1-10	062660512	1	ナベコネジ318-40X5	SCREW, PAN SM3.18-40X5	
5-1-12	111105002	1	シメネジ2.38	SCREW, SM2.38	
5-1-13	151572101	1	フィンガーガード	FINGER GUARD	
5-1-7	S40804001	1	オサエBS5/16	PRESSER FOOT, BS 5/16"	
5-1-7	147876001	1	オサエBS	PRESSER FOOT, BS	
5-2	S40788001	1	オサエ7/64X2クミ	PRESSER FOOT ASSY, 7/64"X2	
5-2-1	S09397001	1	オサエオシバネ	SPRING	
5-2-2	153787001	2	シメネジ2.38	SCREW, SM2.38	
5-2-3	151571001	1	フィンガーガード	FINGER GUARD	
<中厚物用 (MH)>					
14-1	※	1	ラツパーMHクミ	LAPPER ASSY, MH	
14-1-1	105130001	1	シメネジ3.57	SCREW, SM3.57	
<厚物用 (H)>					
14-2	※	1	ラツパーHクミ	LAPPER ASSY, H	
14-2-1	122771001	2	シメネジ2.38	SCREW, SM2.38	

ゲージ関係 (928) / Gauge parts (928) / Lehren (928)
 / Pièces du jauge (928) / Piezas de calibradores (928)

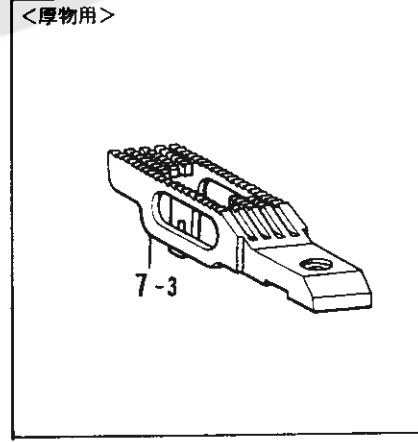
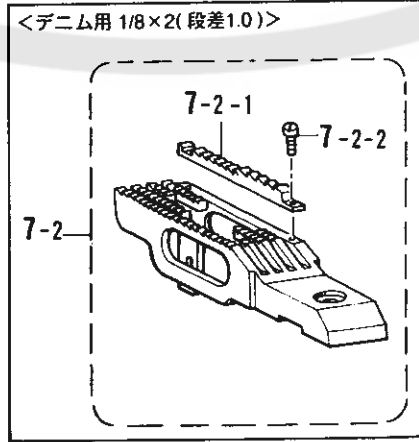
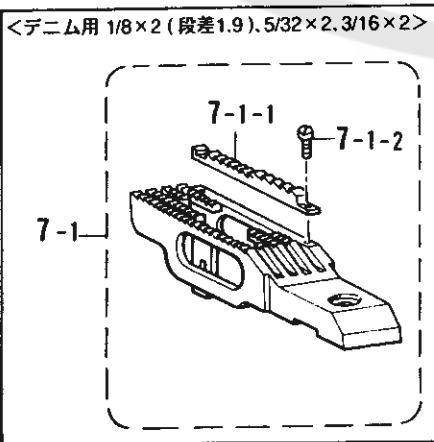
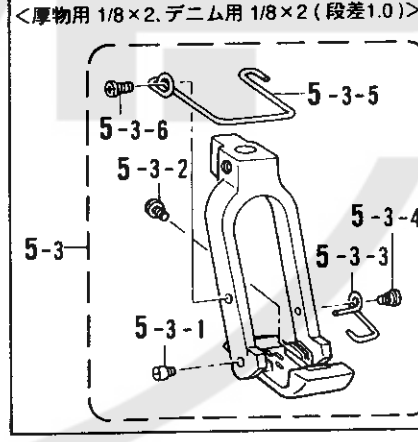
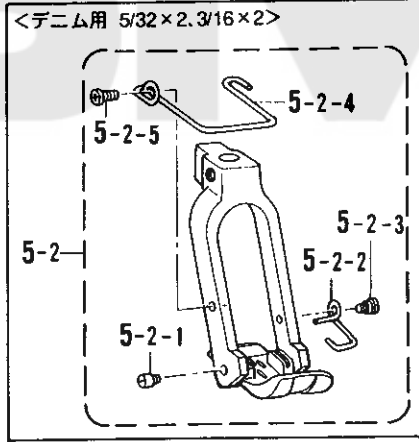
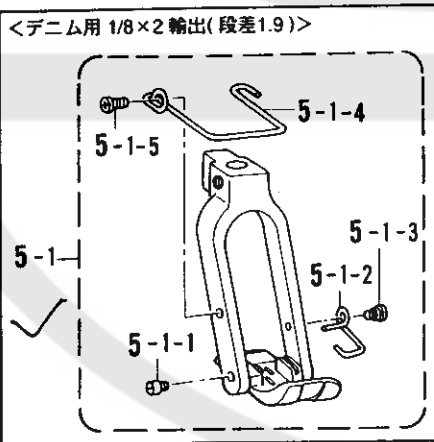
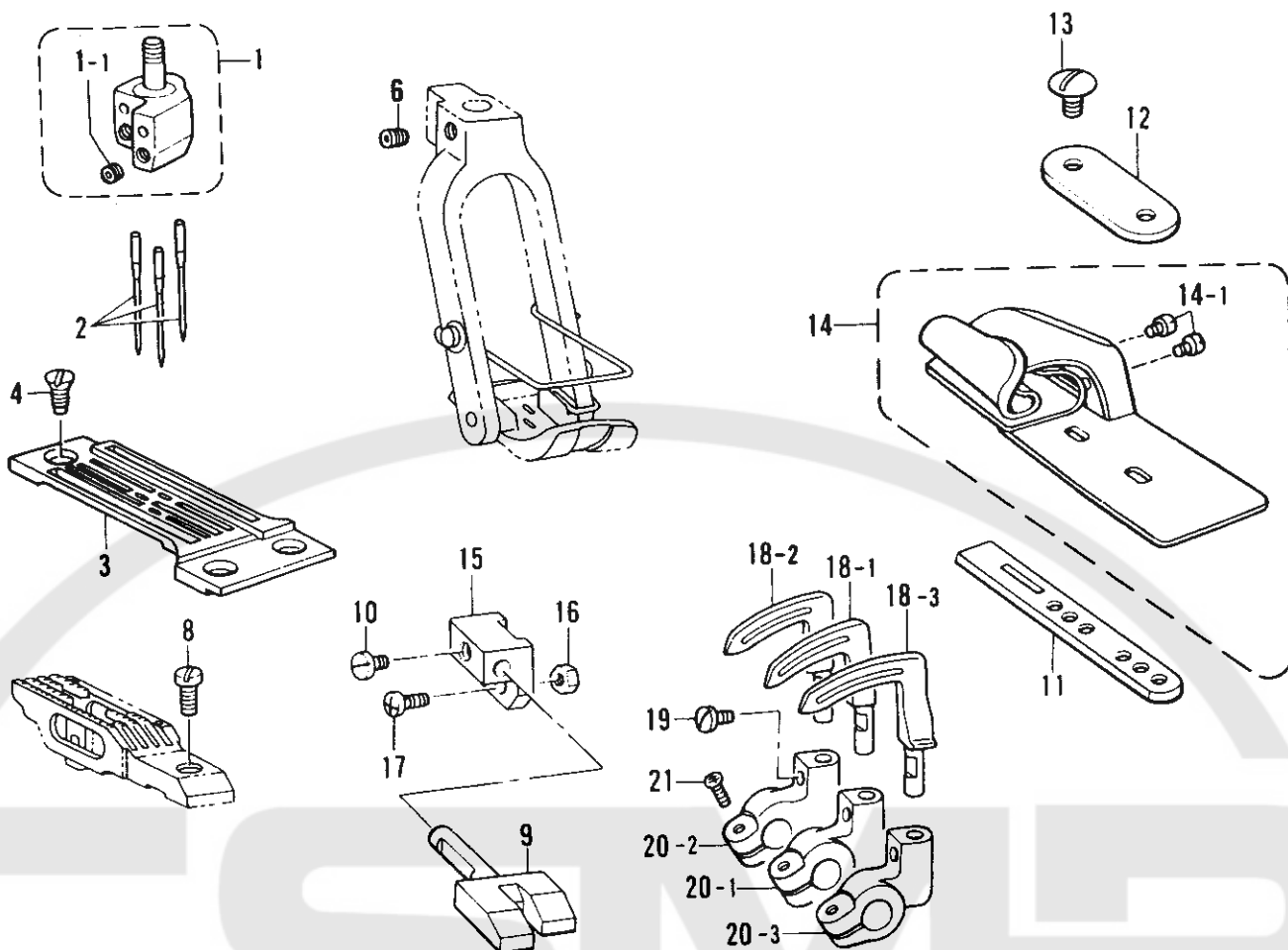

ゲージ関係 (928) / Gauge parts (928) / Lehren (928)
 / Pièces du jauge (928) / Piezas de calibradores (928)

REF.NO.	CODE	Q'TY	品名	NAME OF PARTS	RM
1	※	1	ハリダキクミ	NEEDLE CLAMP ASSY	
1-1	146427001	3	アナトメネジ3.18クボミ	SET SCREW, SOCKET (CP) SM3.18	
2	※	3	ミシンハリTVX5	NEEDLE, TVX5	
3	※	1	ハリイタ	NEEDLE PLATE	
4	100032004	3	サラネジ4.37	SCREW, FLAT SM4.37	
6	014760622	1	アナトメネジ5.95	SET SCREW, SOCKET SM5.95	
8	105173004	1	シメネジ4.76	SCREW, SM4.76	
9	148875001	1	ハリウケ-6	NEEDLE GUARD, -6	
10	111443003	1	マルヒラトメネジ3.57	SET SCREW, SM3.57	
11	S40399001	1	ラツパーアンナイイタ	LAPPER GUIDE PLATE	
12	105129001	1	アンナイイタザガネ	LAPPER GUIDE PLATE WASHER	
13	105130001	2	シメネジ3.57	SCREW, SM3.57	
14	※	1	ラツパークミ	LAPPER ASSY	
14-1	122771001	2	シメネジ2.38	SCREW, SM2.38	
15	148876001	1	ハリウケトリツケダイ	NEEDLE GUARD BRACKET	
16	021670102	1	ナット1シユ3.57	NUT, 1 SM3.57	
17	062671012	1	ナベコ357-40X10	SCREW, PAN SM3.57-40X10	
18-1	※	1	ルーバS	LOPPER, S 1/8"X2-6	
18-2	※	1	ルーバM	LOPPER, M 1/8"X2-6	
18-3	※	1	ルーバL	LOPPER, L 1/8"X2-6	
19	111443003	3	マルヒラトメネジ3.57	SET SCREW, SM3.57	
20-1	S40378051	1	ルーバホルダS	LOPPER HOLDER, S	
20-2	S40379051	1	ルーバホルダM	LOPPER HOLDER, M	
20-3	S40380051	1	ルーバホルダL	LOPPER HOLDER, L	
21	062671012	3	ナベコ357-40X10	SCREW, PAN SM3.57-40X10	

5-1	150672101	1	<デニム用1/8X2輸出段差1.9> オサエ1/8X2-8クミ	<For Export Denim "1/8X2"> PRESSER FOOT ASSY, 1/8"X2-8	
5-1-1	150670001	2	オサエピン	PIN	
5-1-2	150671001	1	オサエFバネ	SPRING	
5-1-3	147932001	1	ダンネジ2.38	SHOULDER SCREW, SM2.38	
5-1-4	156211101	1	フィンガーガード	FINGER GUARD	
5-1-5	060660512	1	バインド318-40X5	SCREW, BIND SM3.18-40X5	
5-2	151487101	1	<デニム用5/32X2, 3/16X2> オサエ5/32X2-8クミ	<For Denim 5/32X2, 3/16X2> PRESSER FOOT ASSY, 5/32"X2-8	
5-2-1	151481001	2	オサエピン	PIN	
5-2-2	151482001	1	オサエFバネ	SPRING	
5-2-3	147932001	1	ダンネジ2.38	SHOULDER SCREW, SM2.38	
5-2-4	156211101	1	フィンガーガード	FINGER GUARD	
5-2-5	060660512	1	バインド318-40X5	SCREW, BIND SM3.18-40X5	
5-3	※	1	<厚物用1/8X2, デニム1/8X2段差1.0> オサエ1/8X2-8クミ	<For Thick & Denim materials "1/8X2"> PRESSER FOOT ASSY, FT 1/8"X2-8	
5-3-1	150670001	2	オサエピン	PIN	
5-3-2	142747002	1	シメネジ4.76	SET SCREW, SM4.76	
5-3-3	150671001	1	オサエFバネ	SPRING	
5-3-4	147932001	1	ダンネジ2.38	SHOULDER SCREW, SM2.38	
5-3-5	156211101	1	フィンガーガード	FINGER GUARD	
5-3-6	060660512	1	バインド318-40X5	SCREW, BIND SM3.18-40X5	

7-1	※	1	<デニム1/8X2段差1.9, 5/32X2, 3/16X2> オクリバクミ	<For Denim "1/8X2, 5/32X2 & 3/16X2"> FEED DOG ASSY, 1/4"-7	
7-1-1	147307001	1	トリツケバ	SUB FEED DOG	
7-1-2	147880001	2	シメネジ1.98	SCREW, SM1.98	
7-2	S01635101	1	<デニム用1/8X2段差1.0> オクリバ1/8X2-8クミ	<For Denim "1.8X2"> FEED DOG ASSY, 1/8"X2-8	
7-2-1	S01637001	1	トリツケバ	SUB FEED DOG	
7-2-2	147880001	2	シメネジ1.98	SCREW, SM1.98	
7-3	156182101	1	<厚物用> オクリバ1/8X2-8	<FOR HEAVY MATERIALS> FEED DOG, 1/8"X2-8	

プーラ装置関係 / Puller device mechanism / Ziehvorrichtung
 / Mécanisme due puller / Mecanismo del dispositivo de arrastre

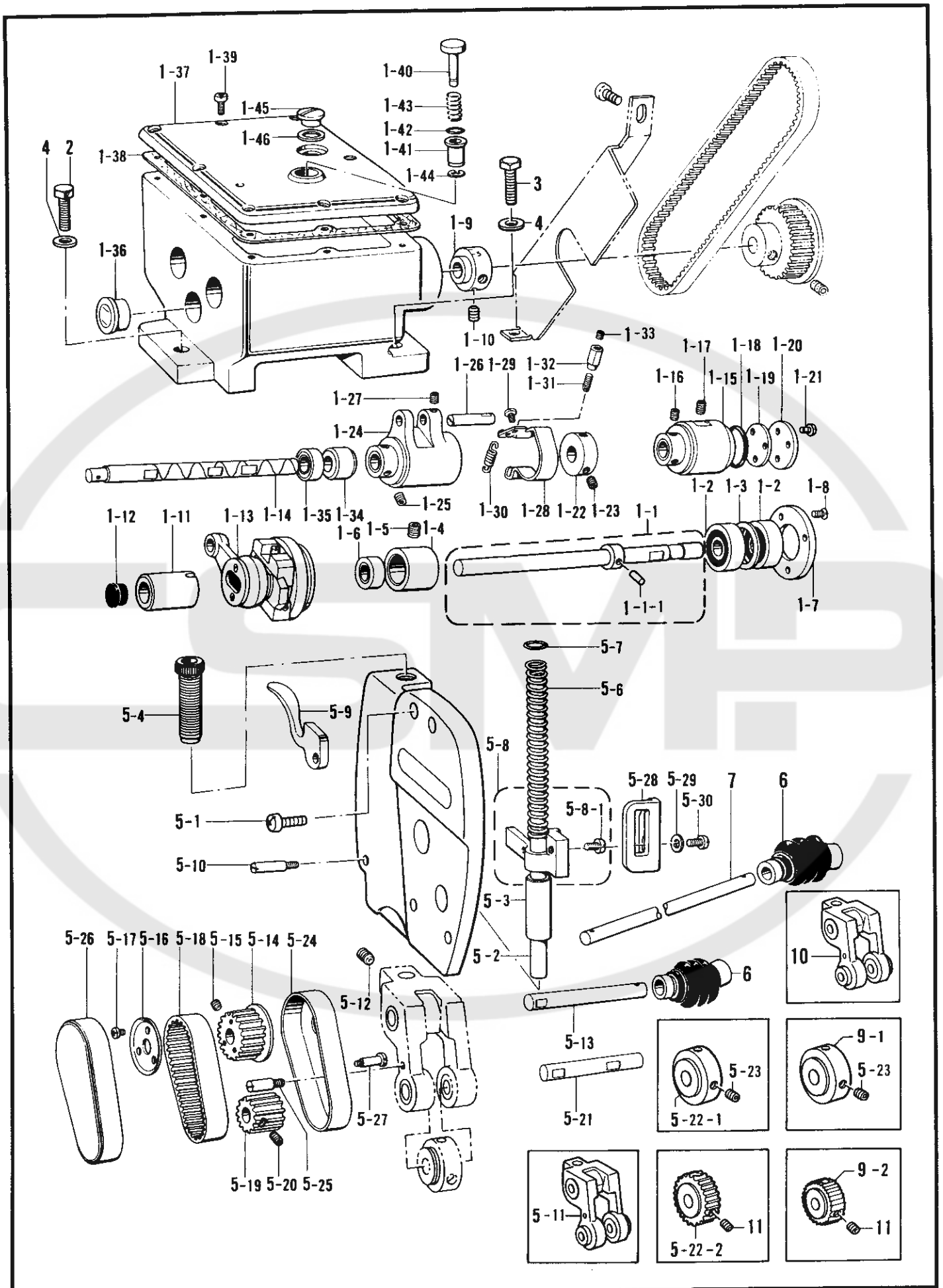

プーラ装置関係 / Puller device mechanism / Ziehvorrichtung

REF.NO.	CODE	Q'TY	ヒンメイ	NAME OF PARTS	RM
1-1	150679001	1	ヘンシンリンジククミ	ECCENTRIC WHEEL SHAFT ASSY	
1-1-1	047201640	1	スプリングヒンAW2	PIN, SPRING ROLL AW2	
1-2	072600040	2	タマジクウケ6000DD	BALL BEARING, 6000DD	
1-3	150682000	1	ベアリングカラー	BEARING COLLAR	
1-4	150683000	1	ベアリングブシュ	BEARING BUSH	
1-5	014760622	1	アナトメネジ5.95	SET SCREW, SOCKET SM5.95	
1-6	150684001	1	オイルシール	OIL SEAL	
1-7	S25125001	1	ベアリングフタ	BEARING COVER	
1-8	062670712	3	ナベコ357-40X7	SCREW, PAN SM3.57-40X7	
1-9	150686101	1	タイミングカラー	TIMING COLLAR	
1-10	014760622	2	アナトメネジ5.95	SET SCREW, SOCKET SM5.95	
1-11	150687000	1	ヘンシンリンジクメタル	ECCENTRIC WHEEL SHAFT BUSH	
1-12	117934009	1	ゴムセン13.5	RUBBER CAP, 13.5	
1-13	150688101	1	ヘンシンリンジクミ	ECCENTRIC WHEEL ASSY	
1-14	150690101	1	オクリジク	FEED SHAFT	
1-15	S36058001	1	クラッチメタルクミ	CLUTCH BUSH ASSY	
1-16	014760622	2	アナトメネジ5.95	SET SCREW, SOCKET SM5.95	
1-17	014760622	1	アナトメネジ5.95	SET SCREW, SOCKET SM5.95	
1-18	081025570	1	OリングP25.5	O RING, P25.5	
1-19	150693000	1	パツキン	PACKING	
1-20	S25126001	1	クラッチメタルフタ	CLUTCH BUSH CAP	
1-21	062670712	3	ナベコ357-40X7	SCREW, PAN SM3.57-40X7	
1-22	150608001	1	セツトカラー	SET SCREW COLLAR	
1-23	014760622	2	アナトメネジ5.95	SET SCREW, SOCKET SM5.95	
1-24	S36061001	1	クラッチクミ	CLUTCH ASSY	
1-25	014760622	2	アナトメネジ5.95	SET SCREW, SOCKET SM5.95	
1-26	109153001	1	ピン	PIN	
1-27	014680422	1	アナトメネジ4.37クボミ	SET SCREW, SOCKET (CP) SM4.37	
1-28	150611001	1	ブレーキイタバネ	PLATE SPRING	
1-29	062680512	2	ナベコ437-40X5	SCREW, PAN SM4.37-40X5	
1-30	150612001	1	ブレーキバネ	SPRING	
1-31	150613001	1	ブレーキバネカケ	SPRING HOOK	
1-32	150614001	1	ブレーキバネカケブシュ	SPRING HOOK BUSH	
1-33	148294001	1	アナトメネジ3.57クボミ	SET SCREW, SOCKET (CP) SM3.57	
1-34	150695000	1	オクリジクメタル	FEED SHAFT BUSH	
1-35	150696001	1	オイルシール	OIL SEAL	
1-36	150697001	1	オイルホツトマド	OIL GAUGE WINDOW	
1-37	150698009	1	プーラウチウフタ	PULLER DEVICE TOP COVER	
1-38	150699000	1	パツキン	PACKING	
1-39	062671012	8	ナベコ357-40X10	SCREW, PAN SM3.57-40X10	
1-40	150641001	1	オクリチヨウセツボタン	FEED ADJUST BUTTON	
1-41	150700001	1	チヨウセツボタンブシュ	FEED REGURATE BUTTON BUSH	
1-42	081003670	1	OリングPW3	O RING, PW3	
1-43	150701001	1	オクリチヨウセツボタンバネ	SPRING	
1-44	048040342	1	トメフE4	RETAINING RING, E4	
1-45	105113001	1	シメネジ12.70	SCREW, SM12.70	
1-46	105215001	1	パツキン	PACKING	
2	017822212	1	ボルト7.94X22	BOLT, SM7.94X22	
3	017821813	2	ボルト7.94X18	BOLT, SM7.94X18	
4	025080132	3	ヒラザガネシヨウ8	WASHER, PLAIN S 8	
5-1	062681012	4	ナベコ437-40X10	SCREW, PAN SM4.37-40X10	
5-2	150704001	1	プーラオサエボウ	PULLER PRESSER BAR	
5-3	S41314000	1	オサエボウメタルD	PRESSER BAR BUSH, D	
5-4	100279109	1	オサエチヨウセツネジ	PRESSER ADJUST SCREW	
5-6	106794001	1	オサエバネ	SPRING	
5-7	141099001	1	オサエバネザガネ	SPRING WASHER	
5-8	183128001	1	オサエバネザガネイクミ	PRESSER BAR GUIDE ASSY	
5-8-1	062680712	1	ナベコ437-40X7	SCREW, PAN SM4.37-40X7	
5-9	112618001	1	オサエアゲ	PRESSER FOOT LIFTER	
5-10	150705001	1	チヨウセツエジク	SUPPORT STUD	
5-12	014770622	1	アナトメネジ6.35クボミ	SET SCREW, SOCKET (CP) SM6.35	
5-13	150711001	1	タイミングプーリジク	TIMING PULLEY SHAFT	
5-14	150712001	1	タイミングプーリクミ	TIMING PULLEY ASSY, C	
5-15	014680422	2	アナトメネジ4.37クボミ	SET SCREW, SOCKET (CP) SM4.37	
5-16	150715001	1	フランジB	FLANGE, B	
5-17	106568003	3	シメネジ3.57	SCREW, SM3.57	
5-18	150716001	1	プーラタイミングベルトB	PULLER TIMING BELT, B	
5-19	150717000	1	タイミングプーリD	TIMING PULLEY, D	
5-20	014680422	2	アナトメネジ4.37クボミ	SET SCREW, SOCKET (CP) SM4.37	
5-21	150718001	1	プーラジク	PULLER SHAFT	
5-24	150720001	1	カバーD	TIMING BELT COVER, D	
5-25	150721001	1	スタッド	STUD	
5-26	150722001	1	カバーU	TIMING BELT COVER, U	
5-27	150723001	1	ダンネジ3.57	SHOULDER SCREW, SM3.57	
5-28	153965001	1	プーラオサエボウアゲ	PULLER PRESSER BAR LIFTER	
5-29	025060232	1	ヒラザガネチユウ6	WASHER, PLAIN M 6	
5-30	062761012	1	ナベコ595-28X10	SCREW, PAN SM5.95-28X10	
6	150725001	2	カバーツギジギテ	UNIVERSAL JOINT ASSY	
7	150726001	1	ツギテジク	UNIVERSAL JOINT SHAFT	
10	S16488001	1	<927用> プーラササエクミ	<FOR 927> PULLER SUPPORT ASSY	
5-11	150706001	1	<928用> プーラササエクミ	<FOR 928> PULLER SUPPORT ASSY	
5-22-1	S06311201	1	<927-7 3/16"用> プーラ	<FOR 927-7, 3/16"> PULLER	
5-23	014680622	2	アナトメネジ4.37クボミ	SET SCREW, SOCKET (CP) SM4.37	
5-22-2	S41315001	1	<928用-7,-8デニム仕様> プーラ	<For 927-7 1/4", -8 & 928 Heavy materials> PULLER	
11	014760622	2	アナトメネジ5.95	SET SCREW, SOCKET SM5.95	
9-1	154344201	1	<927-7 1/4用,-8用,928庫物用> プーラ	<For 927-7 1/4", -8 & 928 Heavy materials> PULLER	
5-23	014680422	2	アナトメネジ4.37クボミ	SET SCREW, SOCKET (CP) SM4.37	
9-2	150719001	1	<928用-8 1/8X2 国内用> プーラ	<For 928-8 1/8X2 Japan> PULLER	
11	014760622	2	アナトメネジ5.95	SET SCREW, SOCKET SM5.95	

下軸関係 / Lower shaft mechanism / Untere Welle / Mécanisme de l'arbre inférieur
/ Mecanismo del eje inferior

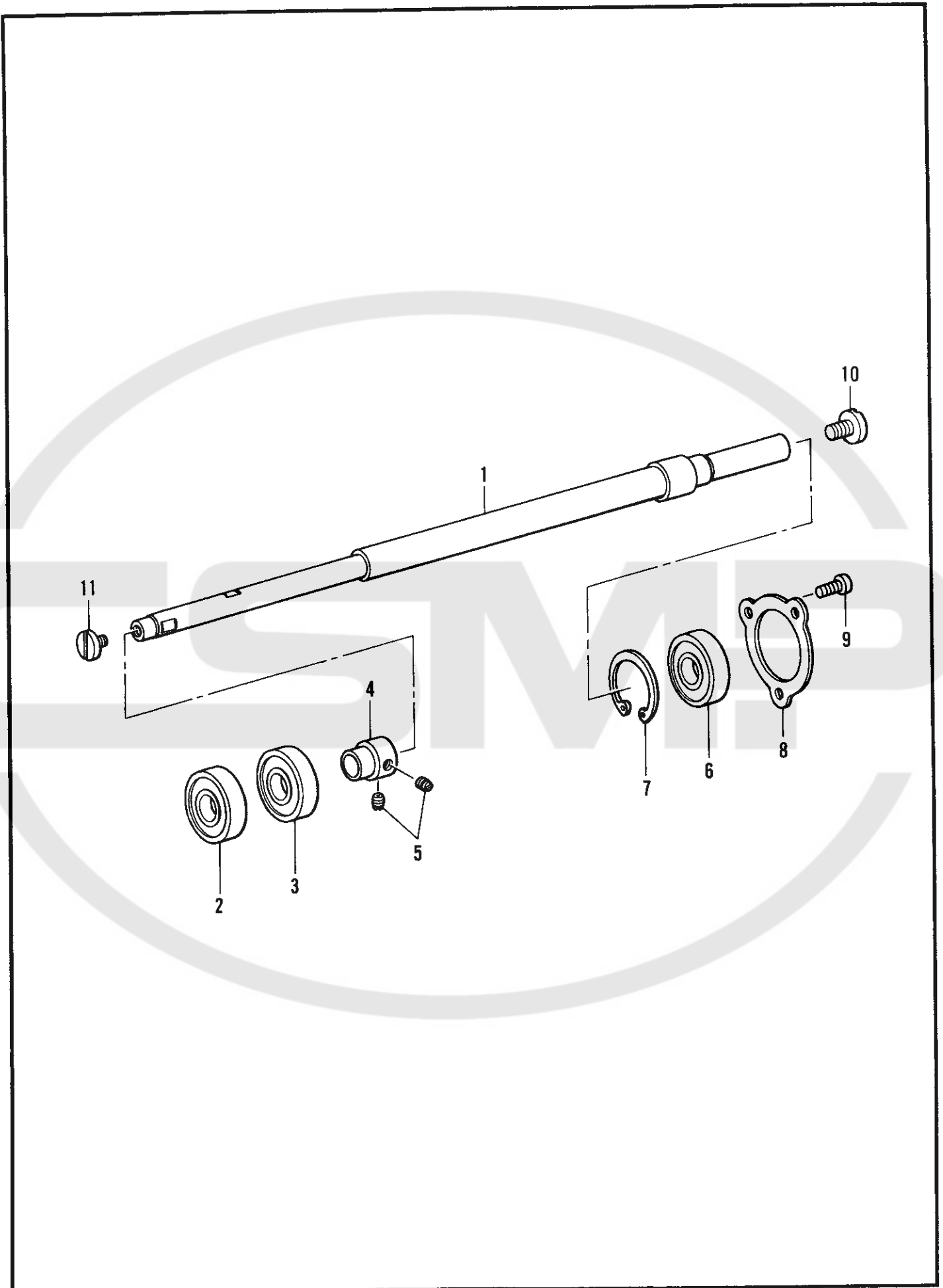

下軸関係 / Lower shaft mechanism / Untere Welle / Mécanisme de l'arbre inférieur
 / Mecanismo del eje inferior

REF.NO.	CODE	Q'TY	ヒンメイ	NAME OF PARTS	RM
1	105147101	1	シタジク	LOWER SHAFT	
2	072620070	1	タマジクウケ6200Z	BALL BEARING, 6200Z	
3	072620180	1	タマジクウケ6201ZZ	BALL BEARING, 6201ZZ	
4	105150000	1	タマジクウケブシユ	BALL BEARING BUSH	
5	102716004	2	トメネジ4.37	SET SCREW, SM4.37	
6	072630260	1	ベアリング6302VV	BALL BEARING, 6302VV	
7	048420242	1	トメワアナヨウC42	RETAINING RING, C42	
8	540316051	1	ベアリングオサエ	BEARING PRESSER	
9	062711012	3	ナベコ476-32X10	SCREW, PAN SM4.76-32X10	
10	105155001	1	シメネジ6.35	SCREW, SM6.35	
11	105156002	1	シメネジ4.37	SCREW, SM4.37	

ルーパー関係 / Looper mechanism / Greifer / Mécanisme des griffes
 / Mecanismo del presilladora

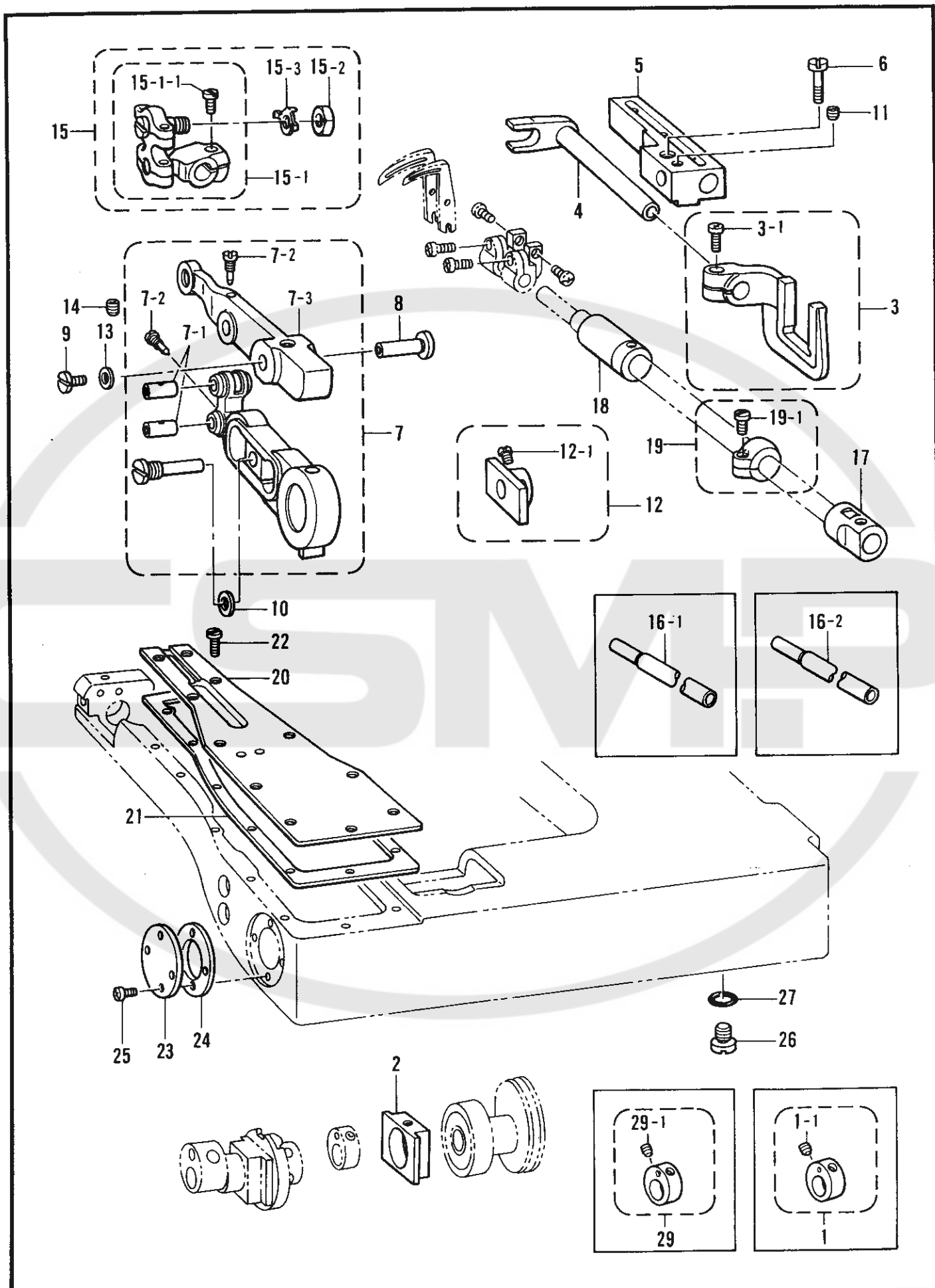

ルーパー関係 / Looper mechanism / Greifer / Mécanisme des griffes
/ Mecanismo del presilladora

REF.NO.	CODE	QTY	ヒンメイ	NAME OF PARTS	RM
2	S40302000	1	ヘンシンリンスリーブ	ECCENTRIC WHEEL SLEEVE	
3	181993101	1	ゼンゴフタマタクミ	LOPPER FEEDING FORK ASSY	
3-1	105176001	1	シメネジ4.37	SCREW, SM4.37	
4	105177001	1	ゼンゴフタマタジク	LOOPER FEEDING FORK SHAFT	
5	105178100	1	ゼンゴフタマタジクウケ	LOPPER F/FORK SHAFT BRACKET	
6	105179001	1	シメネジ4.76	SCREW, SM4.76	
7	S40303001	1	ルーバレンカンクミ	LOPPER CONNECTING ROD ASSY	
7-1	105183001	2	ルーバリンクジク	LOOPER LINK SHAFT	
7-2	105184000	2	シメネジ2.38	SCREW, SM2.38	
7-3	S40792001	1	ルーバレバー	LOPPER LEVER	
8	S40793051	1	ルーバレバージク	LOPPER LEVER SHAFT	
9	105191001	1	シメネジ4.37	SCREW, SM4.37	
10	081010870	1	Oリング S10	O RING, S10	
11	100260001	1	トメネジ5.95	SET SCREW, SM5.95	
12	181987001	1	ルーバレンカンアンナイイタ	LOOPER CONNECT. ROD GUIDE ASSY	
12-1	100366001	2	マルヒラトメネジ4.37	SET SCREW, (FT) SM4.37	
13	081003670	1	OリングPW3	O RING, PW3	
14	014761030	1	アナクボミ 595-28X10	SET SCREW, SOCKET (CP) SM5.95	
15	105193101	1	ルーバジクリンククミ	LOOPER SHAFT LINK ASSY SET	
15-1	183185101	1	ルーバジクリンククミ	LOOPER SHAFT LINK ASSY SET	
15-1-1	105176001	1	シメネジ4.37	SCREW, SM4.37	
15-2	100022004	1	ナツト5.95	NUT, SM5.95	
15-3	105198000	1	タマジクザガネ	WASHER	
17	105201000	1	ルーバジクメタルF	LOOPER SHAFT BUSH, F	
18	148877100	1	ルーバジクメタルB	LOOPER SHAFT BUSH, B	
19	181971001	1	ルーバジクセツトカラー	LOOPER SHAFT SET COLLAR	
19-1	062680812	1	ナベコ437-40X8	SCREW, PAN SM4.37-40X8	
20	S40306001	1	マエオクリウデフタ	FRONT FEED ARM CAP	
21	S40307001	1	マエオクリウデフタバツキン	PACKING	
22	105216001	11	シメネジ3.57	SCREW, SM3.57	
23	105217059	1	タマジクウケフタ	BALL BEARING	
24	S40308001	1	タマジクウケフタバツキン	PACKING	
25	062670512	4	ナベコ357-40X5	SCREW, PAN SM3.57-40X5	
26	140518001	1	シメネジ7.94	SCREW, SM7.94	
27	081007070	1	OリングP7	O RING, P7	
16-1	105200101	1	<927-8以外用> ルーバジク	<FOR 927 WITHOUT "-8"> LOPPER SHAFT	
16-2	S16490101	1	<927-8, 928用> ルーバジク	<FOR 927 "-8" & 928> LOOPER SHAFT	
1	181126001	1	<927中厚物, 928用> ヘンシンリンネジツキ	<For 927 "Medium materials" & 928> ECCENTRIC WHEEL WITH SCREW	
1-1	153675001	2	アナトメネジ4.37	SET SCREW, SOCKET SM4.37	
29	S36862001	1	<927薄物用> ヘンシンリンネジツキ	<FOR 927 THIN MATERIALS > ECCENTRIC WHEEL WITH SCREW	
29-1	153675001	2	アナトメネジ4.37	SET SCREW, SOCKET SM4.37	

上糸通シ関係 (927) / Upper threading mechanism (927) / Obererfadens (927)
 / Mécanisme de l'enfilage supérieur (927) / Mecanismo del enhebrado superior (927)

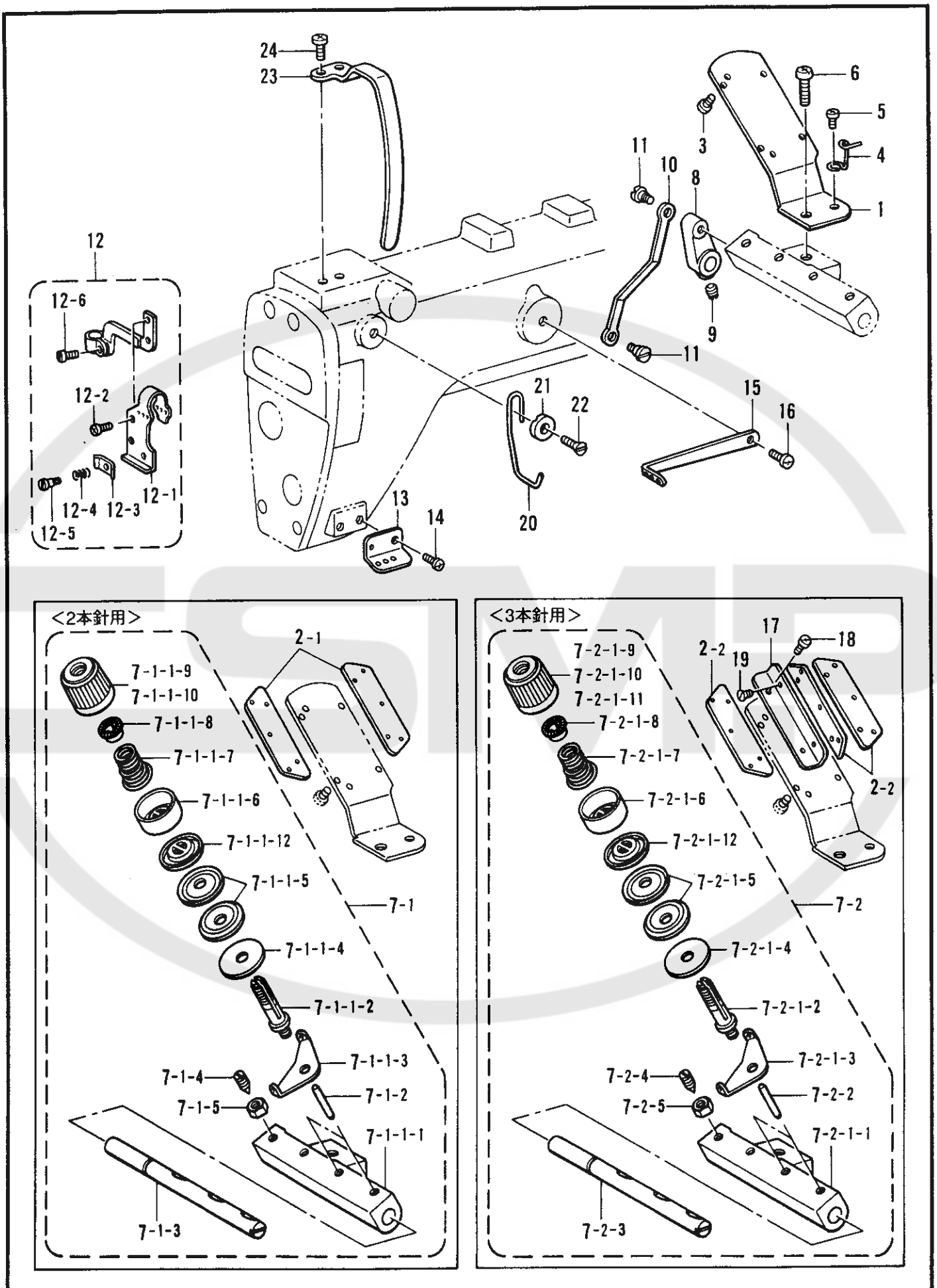

上糸通シ関係(927) / Upper threading mechanism (927) / Obererfadens (927)
 / Mécanisme de l'enfilage supérieur (927) / Mecanismo del enhebrado superior (927)

REF.NO.	CODE	Q'TY	ヒンメイ	NAME OF PARTS	RM
1	111070109	1	ウワイトアンナイダイ	UPPER THREAD GUIDE	
3	062630412	4	ナベコ238-56X4	SCREW, PAN SM2.38-56X4	
4	105222001	1	ウワイトアンナイダイイトカケ	THREAD GUIDE	
5	062670512	1	ナベコ357-40X5	SCREW, PAN SM3.57-40X5	
6	062712012	1	ナベコ476-32X20	SCREW, PAN SM4.76-32X20	
8	105235251	1	イトユルメウデ	TENSION RELEASE CRANK	
9	151602002	1	トメネジ4.37	SET SCREW, SM4.37	
10	105236001	1	イトユルメレンカン	TENSION RELEASE CONNECTING ROD	
11	105237002	2	ダンネジ3.57	SHOULDER SCREW, SM3.57	
12	S40310001	1	ウワイトテンピンクミ	UPPER THREAD TAKE-UP ASSY	
12-1	S40312001	1	ウワイトテンピンイトトオシ	UPPER THREAD GUIDE	
12-2	062660512	2	ナベコ318-40X5	SCREW, PAN SM3.18X5	
12-3	105243001	1	ウワイトテンピンイトオサエ	UPPER THREAD TAKE-UP HOLDER	
12-4	105244000	1	テンピンイトオサエバネ	SPRING	
12-5	105245001	1	ダンネジ2.38	SHOULDER SCREW, SM2.38	
12-6	100064005	1	シメネジ3.57	SCREW, SM3.57	
13	S40313051	1	ハリイトイトアンナイ	UPPER THREAD GUIDE	
14	062670712	1	ナベコ357-40X7	SCREW, PAN SM3.57-40X7	
15	111077001	1	イトユルメレバー	TENSION RELEASE LEVER	
16	060670812	1	バインド357-40X8	SCREW, BIND SM3.57-40X8	
20	111083001	1	ウワイトテンピンイトカケ	UPPER THREAD TAKE-UP GUIDE	
21	111188001	1	イトアンナイザガネ	WASHER	
22	111084001	1	サラネジ3.57	SCREW, FLAT SM3.57	
23	S37186001	1	テンピンカバー	THREAD TAKE-UP COVER	
24	062710812	2	ナベコ476-32X8	SCREW, PAN SM4.76-32X8	
			<2本針用>	<FOR TWIN NEEDLE>	
2-1	105221001	2	ミツメイトカケ	THREAD RETAINER	
7-1	S43446009	1	ウワイトチヨウシクミ	UPPER THREAD REGULATOR ASSY	
7-1-1-1	111075059	1	ウワイトチヨウシボウダイ	UPPER THREAD TENSION BRACKET	
7-1-1-2	145440001	2	イトチヨウシボウ	TENSION STUD	
7-1-1-3	110813001	2	ハリイトアンナイ	NEEDLE THREAD GUIDE	
7-1-1-4	110832009	2	イトチヨウシサラフェルト	TENSION DISC FELT	
7-1-1-5	145446001	4	イトチヨウシサラ	TENSION DISC	
7-1-1-6	144103009	2	イトチヨウシサラオサエ	TENSION DISC PRESSER	
7-1-1-7	144104001	2	ハリイトチヨウシバネ	THREAD TENSION ADJUST SPRING	
7-1-1-8	S30564000	2	チヨウシバネウエザガネ	TENSION SPRING WASHER	
7-1-1-9	S30565002	1	イトチヨウシナツトミドリ	TENSION NUT, GREEN	
7-1-1-10	S30565003	1	イトチヨウシナツトアカ	TENSION NUT, RED	
7-1-1-12	159805001	2	イトチヨウシサラオサエ	TENSION DISC PRESSER	
7-1-2	105231000	2	イトユルメピン	PIN	
7-1-3	111076151	1	イトユルメジク	TENSION RELEASE SHAFT	
7-1-4	105233002	1	トメネジ4.37	SET SCREW, SM4.37	
7-1-5	105234003	1	ナツト4.37	NUT, SM4.37	
			<3本針用>	<FOR THREE NEEDLE>	
2-2	105221001	3	ミツメイトカケ	THREAD RETAINER	
7-2	S43448009	1	ウワイトチヨウシクミ	UPPER THREAD REGULATOR ASSY	
7-2-1-1	111075059	1	ウワイトチヨウシボウダイ	UPPER THREAD TENSION BRACKET	
7-2-1-2	145440001	3	イトチヨウシボウ	TENSION STUD	
7-2-1-3	110813001	3	ハリイトアンナイ	NEEDLE THREAD GUIDE	
7-2-1-4	110832009	3	イトチヨウシサラフェルト	TENSION DISC FELT	
7-2-1-5	145446001	6	イトチヨウシサラ	TENSION DISC	
7-2-1-6	144103009	3	イトチヨウシサラオサエ	TENSION DISC PRESSER	
7-2-1-7	144104001	3	ハリイトチヨウシバネ	THREAD TENSION ADJUST SPRING	
7-2-1-8	S30564000	3	チヨウシバネウエザガネ	TENSION SPRING WASHER	
7-2-1-9	S30565002	1	イトチヨウシナツトミドリ	TENSION NUT, GREEN	
7-2-1-10	S30565003	1	イトチヨウシナツトアカ	TENSION NUT, RED	
7-2-1-11	S30565004	1	イトチヨウシナツトキイ	TENSION NUT, YELLOW	
7-2-1-12	159805001	3	イトチヨウシサラオサエ	TENSION DISC PRESSER	
7-2-2	105231000	3	イトユルメピン	PIN	
7-2-3	111076151	1	イトユルメジク	TENSION RELEASE SHAFT	
7-2-4	105233002	1	トメネジ4.37	SET SCREW, SM4.37	
7-2-5	105234003	1	ナツト4.37	NUT, SM4.37	
17	111072009	1	ミツメイトアンナイトリツケイタ	THREAD GUIDE SET PLATE	
18	062630412	2	ナベコ238-56X4	SCREW, PAN SM2.38-56X4	
19	111073001	2	サラネジ2.38	SCREW, FLAT SM2.38	

上糸通シ関係 (928) / Upper threading mechanism (928) / Obererfadens (928)
 / Mécanisme de l'enfilage supérieur (928) / Mecanismo del enhebrado superior (928)

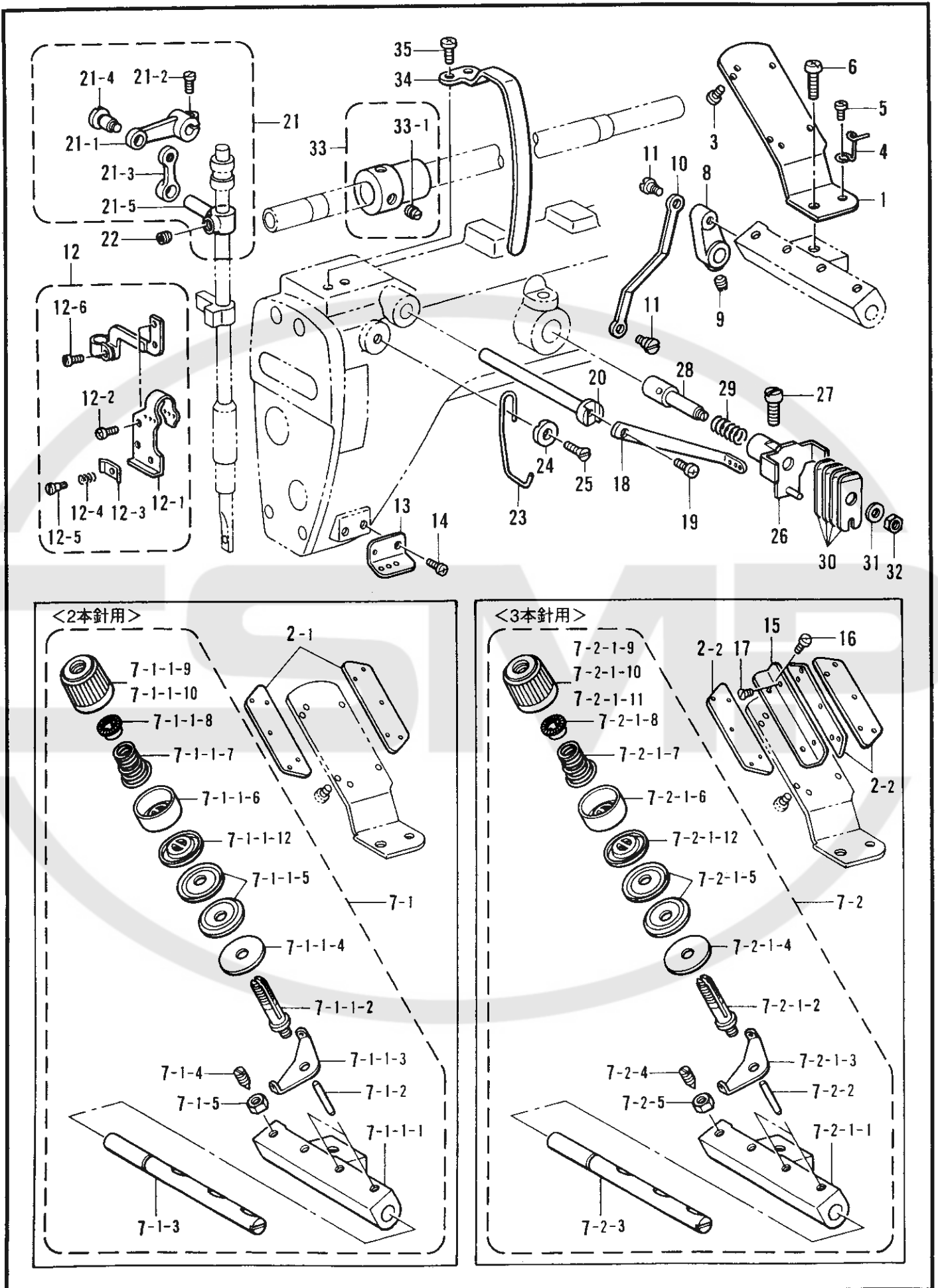

上糸通シ関係 (928) / Upper threading mechanism (928) / Obererfadens (928)
 / Mécanisme de l'enfilage supérieur (928) / Mecanismo del enhebrado superior (928)

REF.NO.	CODE	Q'TY	品名	NAME OF PARTS	RM
1	111070109	1	ウワイトアンナイダイ	UPPER THREAD GUIDE	
3	062630412	4	ナベコ238-56X4	SCREW, PAN SM2.38-56X4	
4	105222001	1	ウワイトアンナイダイイトカケ	THREAD GUIDE	
5	062670512	1	ナベコ357-40X5	SCREW, PAN SM3.57-40X5	
6	062712012	1	ナベコ476-32X20	SCREW, PAN SM4.76-32X20	
8	105235251	1	イトユルメウデ	TENSION RELEASE CRANK	
9	151602002	1	トメネジ4.37	SET SCREW, SM4.37	
10	105236001	1	イトユルメレンカン	TENSION RELEASE CONNECTING ROD	
11	105237002	2	ダンネジ3.57	SHOULDER SCREW, SM3.57	
12	S40310001	1	ウワイトテンピンクミ	UPPER THREAD TAKE-UP ASSY	
12-1	S40312001	1	ウワイトテンピンイトトオシ	UPPER THREAD GUIDE	
12-2	062660512	2	ナベコネジ318-40X5	SCREW, PAN SM3.18-40X5	
12-3	105243001	1	ウワイトテンピンイトオサエ	UPPER THREAD TAKE-UP HOLDER	
12-4	105244000	1	テンピンイトオサエバネ	SPRING	
12-5	105245001	1	ダンネジ2.38	SHOULDER SCREW, SM2.38	
12-6	100064005	1	シメネジ3.57	SCREW, SM3.57	
13	S40313051	1	ハリイトイトアンナイ	UPPER THREAD GUIDE	
14	062670712	1	ナベコ357-40X7	SCREW, PAN SM3.57-40X7	
18	111077001	1	イトユルメラバー	TENSION RELEASE LEVER	
19	060670612	1	バインド357-40X6	SCREW, BIND SM3.57-40X6	
20	111078051	1	イトユルメラバジク	TENSION RELEASE LEVER SHAFT	
21	111506101	1	イトユルメレンカンクミ	T/RELEASE CONNECTING ROD ASSY	
21-1	111079001	1	イトユルメレンカン	TENSION RELEASE CONNECTING ROD	
21-2	100064005	1	シメネジ3.57	SCREW, SM3.57	
21-3	149011051	1	イトユルメリリンク	TENSION RELEASE LINK	
21-4	115132002	1	ダンネジ4.76	SHOULDER SCREW, M4.76	
21-5	111082051	1	イトユルメスタッド	TENSION RELEASE STUD	
22	013760610	1	トメネジ5.95クボミ	SET SCREW, (CP) SM5.95	
23	111083001	1	ウワイトテンピンイトカケ	UPPER THREAD TAKE-UP GUIDE	
24	111188001	1	イトアンナイザガネ	WASHER	
25	111084001	1	サラネジ3.57	SCREW, FLAT SM3.57	
26	111089001	1	ウワイトシメチヨウシダイ	UPPER THREAD TENSION BRACKET	
27	105073001	1	アタマツキトメネジ5.95	SET SCREW, SOCKET SM5.95	
28	111189001	1	ウワイトシメボウクミ	UPPER THREAD STUD ASSY	
29	111093001	1	ウワイトシメオシバネ	SPRING	
30	105277001	4	シタイトチヨウシイタ	LOWER THREAD TENSION PLATE	
31	100645003	1	ザガネ	WASHER	
32	105234003	1	ナツト4.37	NUT, SM4.37	
33	181060001	1	ウワイトシメカムネジツキ	UPPER THREAD CAM WITH SCREW	
33-1	100058003	2	トメネジ5.95	SET SCREW, SM5.95	
34	S37186001	1	テンピンカパー	THREAD TAKE-UP COVER	
35	062710812	2	ナベコ476-32X8	SCREW, PAN SM4.76-32X8	
			<<2本針用>>	<<FOR TWIN NEEDLE>>	
2-1	105221001	2	ミツメイトカケ	THREAD RETAINER	
7-1	S41316009	1	ウワイトチヨウシクミ	UPPER THREAD REGULATOR ASSY	
7-1-1-1	111075059	1	ウワイトチヨウシボウダイ	UPPER THREAD TENSION BRACKET	
7-1-1-2	145440001	2	イトチヨウシボウ	TENSION STUD	
7-1-1-3	110813001	2	ハリイトアンナイ	NEEDLE THREAD GUIDE	
7-1-1-4	110832009	2	イトチヨウシサラフェルト	TENSION DISC FELT	
7-1-1-5	145446001	4	イトチヨウシサラ	TENSION DISC	
7-1-1-6	144103009	2	イトチヨウシサラオサエ	TENSION DISC PRESSER	
7-1-1-7	148851001	2	ハリイトチヨウシバネ	THREAD TENSION ADJUST SPRING	
7-1-1-8	S30564000	2	チヨウシバネウエザガネ	TENSION SPRING WASHER	
7-1-1-9	S30565002	1	イトチヨウシナツトミドリ	TENSION NUT, GREEN	
7-1-1-10	S30565003	1	イトチヨウシナツトアカ	TENSION NUT, RED	
7-1-1-12	159805001	2	イトチヨウシサラオサエ	TENSION DISC PRESSER	
7-1-2	105231000	2	イトユルメピン	PIN	
7-1-3	111076151	1	イトユルメジク	TENSION RELEASE SHAFT	
7-1-4	105233002	1	トメネジ4.37	SET SCREW, SM4.37	
7-1-5	105234003	1	ナツト4.37	NUT, SM4.37	
			<<3本針用>>	<<FOR THREE NEEDLE>>	
2-2	105221001	3	ミツメイトカケ	THREAD RETAINER	
7-2	S41318009	1	ウワイトチヨウシクミ	UPPER THREAD REGULATOR ASSY	
7-2-1-1	111075059	1	ウワイトチヨウシボウダイ	UPPER THREAD TENSION BRACKET	
7-2-1-2	145440001	3	イトチヨウシボウ	TENSION STUD	
7-2-1-3	110813001	3	ハリイトアンナイ	NEEDLE THREAD GUIDE	
7-2-1-4	110832009	3	イトチヨウシサラフェルト	TENSION DISC FELT	
7-2-1-5	145446001	6	イトチヨウシサラ	TENSION DISC	
7-2-1-6	144103009	3	イトチヨウシサラオサエ	TENSION DISC PRESSER	
7-2-1-7	148851001	3	ハリイトチヨウシバネ	THREAD TENSION ADJUST SPRING	
7-2-1-8	S30564000	3	チヨウシバネウエザガネ	TENSION SPRING WASHER	
7-2-1-9	S30565002	1	イトチヨウシナツトミドリ	TENSION NUT, GREEN	
7-2-1-10	S30565003	1	イトチヨウシナツトアカ	TENSION NUT, RED	
7-2-1-11	S30565004	1	イトチヨウシナツトキイ	TENSION NUT, YELLOW	
7-2-1-12	159805001	3	イトチヨウシサラオサエ	TENSION DISC PRESSER	
7-2-2	105231000	3	イトユルメピン	PIN	
7-2-3	111076151	1	イトユルメジク	TENSION RELEASE SHAFT	
7-2-4	105233002	1	トメネジ4.37	SET SCREW, SM4.37	
7-2-5	105234003	1	ナツト4.37	NUT, SM4.37	
15	111072009	1	ミツメイトアンナイトリツケイタ	THREAD GUIDE SET PLATE	
16	062630412	2	ナベコ238-56X4	SCREW, PAN SM2.38-56X4	
17	111073001	2	サラネジ2.38	SCREW, FLAT SM2.38	

下糸通シ関係 (927) / Lower threading mechanism (927) / Untererfadens (927)
 / Mécanisme de l'enfilage inférieur (927) / Mecanismo de le enhebrado inferior (927)

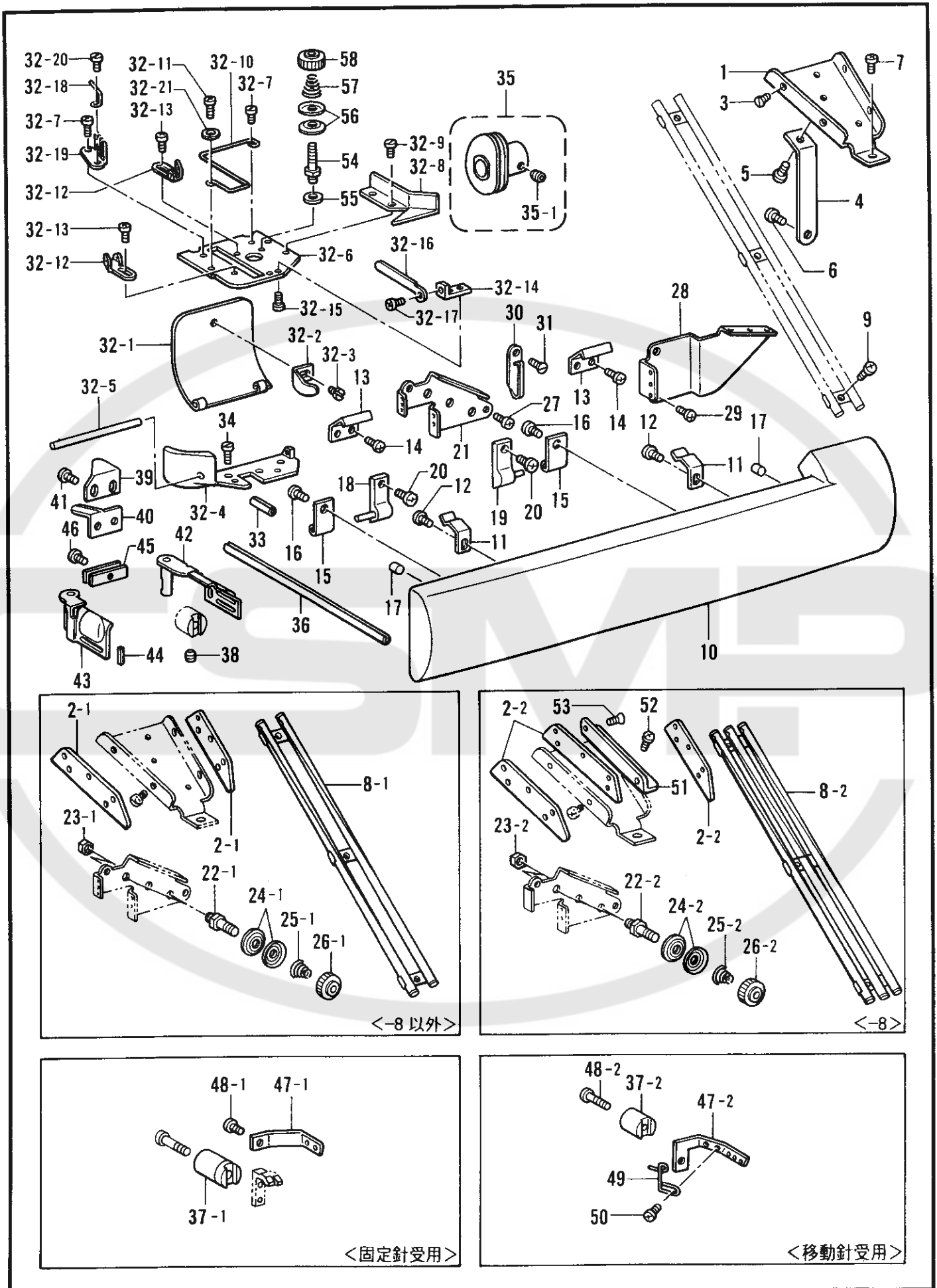

下糸通シ関係 (927) / Lower threading mechanism (927) / Untererfadens (927)
 / Mécanisme de l'enfilage inférieur (927) / Mecanismo de le enhebrado inferior (927)

REF.NO.	CODE	Q'TY	品名	NAME OF PARTS	RM
1	111095009	1	シタイトアンナイダイ	LOWER THREAD GUIDE RETAINER	
3	111073001	4	サラネジ2.38	SCREW, FLAT SM2.38	
4	111096009	1	シタイトアンナイササエ	LOWER THREAD GUIDE SUPPORT	
5	062670412	1	ナベコ357-40X4	SCREW, PAN SM3.57-40X4	
6	062670512	1	ナベコ357-40X5	SCREW, PAN SM3.57-40X5	
7	062671012	1	ナベコ357-40X10	SCREW, PAN SM3.57-40X10	
9	062670812	3	ナベコ3.57-40X8	SCREW, PAN SM3.57-40X8	
10	S40319001	1	マエカバー	FRONT COVER	
11	S40320051	2	マエカバートメバネ	FRONT COVER SPRING	
12	060670512	2	バンド357-40X5	SCREW, BIND SM3.57-40X5	
13	S40321051	2	マエカバーフック	FRONT COVER HOOK	
14	062670612	4	ナベコ357-40X6	SCREW, PAN SM3.57-40X6	
15	S40322051	2	マエカバーヒンジ	HINGE	
16	062670612	2	ナベコ357-40X6	SCREW, PAN SM3.57-40X6	
17	142274009	2	ゴムセン4.2	RUBBER CAP, 4.2	
18	105257009	1	アンナイフタヒンジLクミ	L/THREAD GUIDE HINGE ASSY, L	
19	105260009	1	アンナイフタヒンジRクミ	L/THREAD GUIDE HINGE ASSY, R	
20	062671012	2	ナベコ357-40X10	SCREW, PAN SM3.57-40X10	
21	S40323001	1	シタイトチヨウシダイ	LOWER THREAD TENSION BRACKET	
27	062670612	2	ナベコ357-40X6	SCREW, PAN SM3.57-40X6	
28	S40325001	1	シタイトアンナイ	LOWER THREAD GUIDE	
29	062670612	2	ナベコ357-40X6	SCREW, PAN SM3.57-40X6	
30	112658001	1	アームイトアンナイM	ARM THREAD GUIDE, M	
31	108960002	1	サラネジ3.57	SCREW, FLAT SM3.57	
32	S40266051	1	シタイトテンビンダイクミ	LOWER THREAD TAKE-UP BRACKET	
32-1	105280009	1	シタイトテンビンフタ	L/THREAD TAKE-UP LEVER COVER	
32-2	105281001	1	テンビンフタトメイタバネ	SPRING, PLATE	
32-3	122771002	1	シメネジ2.38	SCREW, SM2.38	
32-4	105284101	1	シタイトテンビンダイササエ	L/TR. TAKE-UP LEVER BRACKET	
32-5	105285000	1	シタイトテンビンフタジク	L/TR. TAKE-UP LEVER COV. SHAFT	
32-6	S40326051	1	シタイトテンビンダイ	L/TR. TAKE-UP LEVER BRACKET	
32-7	062670612	2	ナベコ357-40X6	SCREW, PAN SM3.57-40X6	
32-8	105287001	1	テンビンダイアンナイイタ	GUIDE PLATE	
32-9	105288001	2	シメネジ2.38	SCREW, SM2.38	
32-10	S40327051	1	テンビンイトウケ	LOWER THREAD GUIDE	
32-11	060660416	1	バンド318-40X4	SCREW, BIND SM3.18-40X4	
32-12	S40795101	2	DLテンビンイトアンナイ	LOWER THREAD GUIDE	
32-13	060660416	2	バンド318-40X4	SCREW, BIND SM3.18-40X4	
32-14	S40328051	1	イトオサエドダイ	THREAD RELEASE BASE	
32-15	062660412	2	ナベコ318-40X4	SCREW, PAN SM3.18-40X4	
32-16	S40329051	1	テンビンイトオサエ	LOWER THREAD PRESSER	
32-17	062660412	1	ナベコ318-40X4	SCREW, PAN SM3.18-40X4	
32-18	105296001	1	テンビンダイイトカケ	THREAD GUIDE	
32-19	111112001	1	シタイトイトアンナイイタ	LOWER THREAD GUIDE PLATE	
32-20	105288001	1	シメネジ2.38	SCREW, SM2.38	
32-21	026030136	1	ヒラザガネコガタ3	WASHER, PLAIN S 3	
33	047501242	1	スプリングピンAW5	PIN, SPRING ROLL AW5	
34	100064005	2	シメネジ3.57	SCREW, SM3.57	
35	S40330051	1	シタイトテンビンネジツキM	LOWER THREAD TAKE-UP W/S, M	
35-1	014680422	2	アナトメネジ4.37クボミ	SET SCREW, SOCKET (CP) SM4.37	
36	105300101	1	シタイトオクリダシアンナイ	LOWER THREAD FEED BAR GUIDE	
38	013760610	1	トメネジ5.95クボミ	SET SCREW, (CP) SM5.95	
39	111113101	1	イトキリアンナイイタ	THREAD TRIMMER GUIDE PLATE	
40	111114101	1	イトキリ	THREAD TRIMMER	
41	062670612	2	ナベコ357-40X6	SCREW, PAN SM3.57-40X6	
42	S40335051	1	ルーバガワフタRA	LOOPER COVER, RA	
43	S40338051	1	ルーバガワフタLA	LOOPER COVER, LA	
44	047200842	1	スプリングピンAW2	PIN, SPRING ROLL AW2	
45	S40799051	2	ルーバガワフタトメバネ	SPRING	
46	062670712	1	ナベコ357-40X7	SCREW, PAN SM3.57-40X7	
54	S08987001	1	イトチヨウシボウ	THREAD TENSION CONTROL STUD	
55	146354001	1	ザガネ	WASHER, PLAIN S	
56	144504001	2	イトアンナイサラ	THREAD GUIDE DISC	
57	S40324001	1	イトアンナイバネ	THREAD GUIDE SPRING	
58	155510001	1	イトチヨウシナット	TENSION NUT	
2-1	105221001	2	<-8以外用> ミツメイトカケ	<FOR WITHOUT "-8"> THREAD RETAINER	
8-1	105251009	1	シタイトタテアンナイクミ	INGLINED GUIDE TUBE ASSY	
22-1	S08987001	2	イトチヨウシボウ	THREAD TENSION CONTROL STUD	
23-1	021680202	2	ナット2シユ4.37	NUT, 2 SM4.37	
24-1	144504001	4	イトアンナイサラ	THREAD GUIDE DISC	
25-1	S40324001	2	イトアンナイバネ	THREAD GUIDE SPRING	
26-1	155510001	2	イトチヨウシナット	TENSION NUT	
2-2	105221001	3	<-8用> ミツメイトカケ	<FOR "-81"> THREAD RETAINER	
8-2	111097009	1	シタイトタテアンナイクミ	INGLINED GUIDE TUBE ASSY	
22-2	S08987001	3	イトチヨウシボウ	THREAD TENSION CONTROL STUD	
23-2	021680202	3	ナット2シユ4.37	NUT, 2 SM4.37	
24-2	144504001	6	イトアンナイサラ	THREAD GUIDE DISC	
25-2	S40324001	3	イトアンナイバネ	THREAD GUIDE SPRING	
26-2	155510001	3	イトチヨウシナット	TENSION NUT	
51	111072009	1	ミツメイトアンナイトリツケイタ	THREAD GUIDE SET PLATE	
52	062630412	2	ナベコ238-56X4	SCREW, PAN SM2.38-56X4	
53	111073001	2	サラネジ2.38	SCREW, FLAT SM2.38	
37-1	105301001	1	<固定針受用> ルーハイトアンナイダイ	<FOR "FIX NEEDLE SUPPORT"> LOOPER THREAD GUIDE BRACKET	
47-1	105304001	1	ルーハイトアンナイ	LOOPER THREAD GUIDE	
48-1	062660612	1	ナベコ318-40X6	SCREW, PAN SM3.18-40X6	
37-2	147291001	1	<移動針受用> ルーハイトアンナイダイ	<FOR "MOVEABLE NEEDLE SUPPORT"> LOOPER THREAD GUIDE BRACKET	
47-2	S16487151	1	ルーハイトアンナイ-8	LOOPER THREAD GUIDE, -8	
48-2	062671412	1	ナベコ357-40X14	SCREW, PAN SM3.57-40X14	
49	S40341001	1	ルーハイトアンナイ	LOOPER THREAD GUIDE	
50	062630412	2	ナベコ238-56X4	SCREW, PAN SM2.38-56X4	



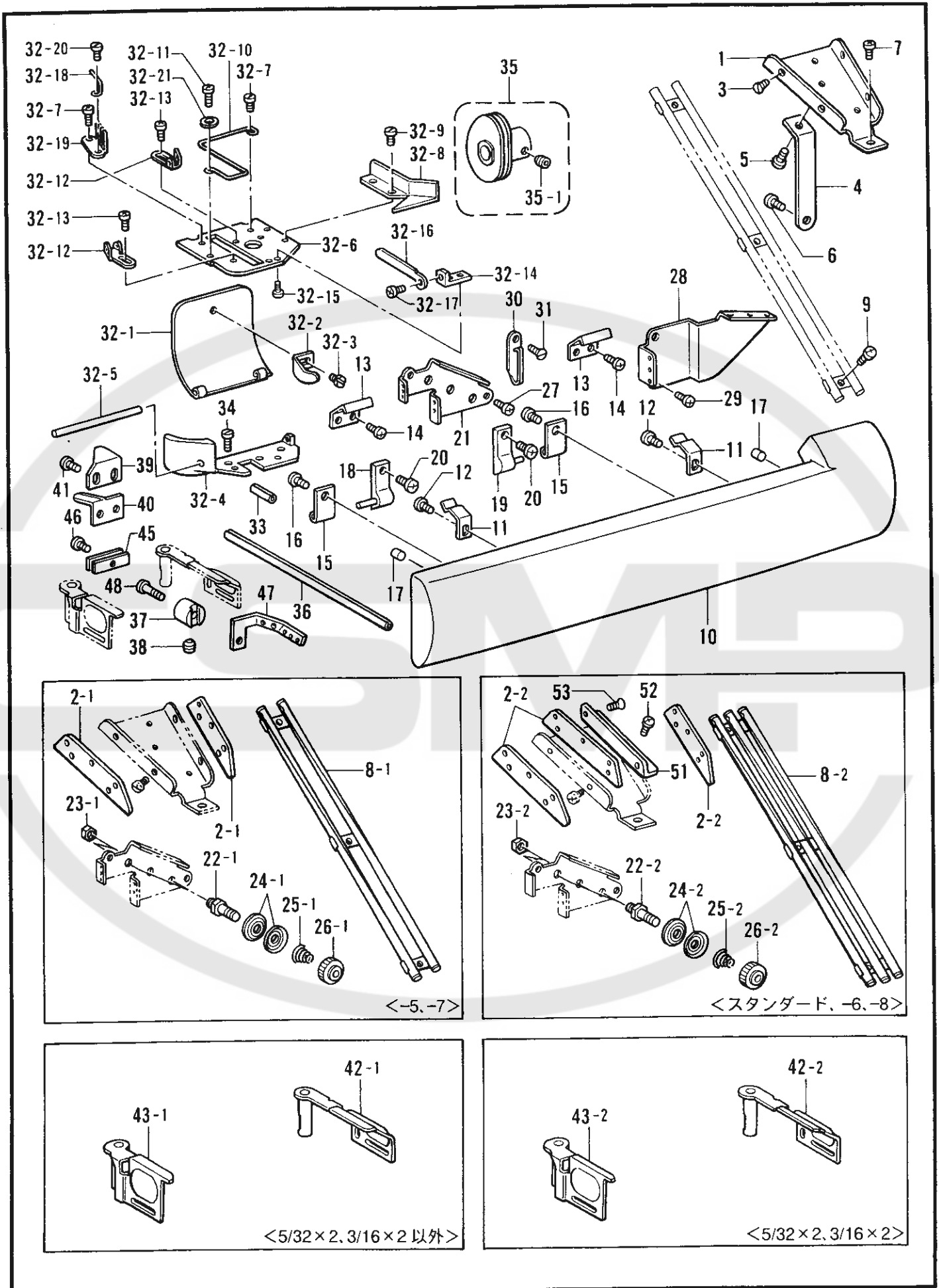















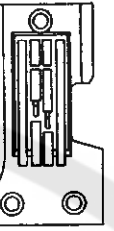
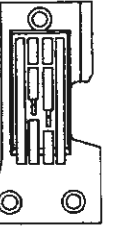
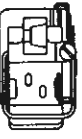







下糸通シ関係 (928) / Lower threading mechanism (928) / Untererfadens (928)
 / Mécanisme de l'enfilage inférieur (928) / Mecanismo de le enhebrado inferior (928)

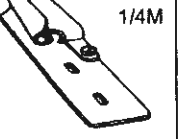
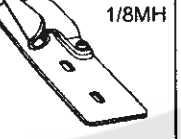
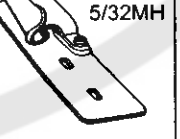
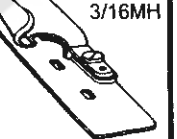

下糸通シ関係 (928) / Lower threading mechanism (928) / Untererfadens (928)
 / Mécanisme de l'enfilage inférior (928) / Mecanismo de le enhebrado inferior (928)

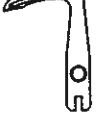
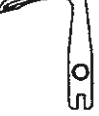
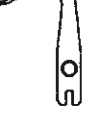
REF.NO.	CODE	Q'TY	品名	NAME OF PARTS	RM
1	111095009	1	シタイトアンナイダイ	LOWER THREAD GUIDE RETAINER	
3	111073001	4	サラネジ2.38	SCREW, FLAT SM2.38	
4	111096009	1	シタイトアンナイササエ	LOWER THREAD GUIDE SUPPORT	
5	062670412	1	ナベコ357-40X4	SCREW, PAN SM3.57-40X4	
6	062670512	1	ナベコ357-40X5	SCREW, PAN SM3.57-40X5	
7	062671012	1	ナベコ357-40X10	SCREW, PAN SM3.57-40X10	
9	062670812	3	ナベコ3.57-40X8	SCREW, PAN SM3.57-40X8	
10	S40319001	1	マエカバー	FRONT COVER	
11	S40320051	2	マエカバートメバネ	FRONT COVER SPRING	
12	060670512	2	バインド357-40X5	SCREW, BIND SM3.57-40X5	
13	S40321051	2	マエカバーフック	FRONT COVER HOOK	
14	062670612	4	ナベコ357-40X6	SCREW, PAN SM3.57-40X6	
15	S40322051	2	マエカバーヒンジ	HINGE	
16	062670612	2	ナベコ357-40X6	SCREW, PAN SM3.57-40X6	
17	142274009	2	ゴムセン4.2	RUBBER CAP, 4.2	
18	105257009	1	アンナイフタヒンジLクミ	L/THREAD GUIDE HINGE ASSY, L	
19	105260009	1	アンナイフタヒンジRクミ	L/THREAD GUIDE HINGE ASSY, R	
20	062671012	2	ナベコ357-40X10	SCREW, PAN SM3.57-40X10	
21	S40323001	1	シタイトチヨウシダイ	LOWER THREAD TENSION BRACKET	
27	062670612	2	ナベコ357-40X6	SCREW, PAN SM3.57-40X6	
28	S40325001	1	シタイトアンナイ	LOWER THREAD GUIDE	
29	062670612	2	ナベコ357-40X6	SCREW, PAN SM3.57-40X6	
30	112658001	1	アームイトアンナイM	ARM THREAD GUIDE, M	
31	108960002	1	サラネジ3.57	SCREW, FLAT SM3.57	
32	S40266051	1	シタイトテンビンダイクミ	LOWER THREAD TAKE-UP BRACKET	
32-1	105280009	1	シタイトテンビンフタ	L/THREAD TAKE-UP LEVER COVER	
32-2	105281001	1	テンビンフタトメイタバネ	SPRING, PLATE	
32-3	122771002	1	シメネジ2.38	SCREW, SM2.38	
32-4	105284101	1	シタイトテンビンダイササエ	L/TR. TAKE-UP LEVER BRACKET	
32-5	105285000	1	シタイトテンビンフタジク	L/TR. TAKE-UP LEVER COV. SHAFT	
32-6	S40326051	1	シタイトテンビンダイ	L/TR. TAKE-UP LEVER BRACKET	
32-7	062670612	2	ナベコ357-40X6	SCREW, PAN SM3.57-40X6	
32-8	105287001	1	テンビンダイアンナイイタ	GUIDE PLATE	
32-9	105288001	2	シメネジ2.38	SCREW, SM2.38	
32-10	S40327051	1	テンビンイトウケ	LOWER THREAD GUIDE	
32-11	060660416	1	バインド318-40X4	SCREW, BIND SM3.18-40X4	
32-12	S40795101	2	DLテンビンイトアンナイ	LOWER THREAD GUIDE	
32-13	060660416	2	バインド318-40X4	SCREW, BIND SM3.18-40X4	
32-14	S40328051	1	イトオサエドダイ	THREAD RELEASE BASE	
32-15	062660412	2	ナベコ318-40X4	SCREW, PAN SM3.18-40X4	
32-16	S40329051	1	テンビンイトオサエ	LOWER THREAD PRESSER	
32-17	062660412	1	ナベコ318-40X4	SCREW, PAN SM3.18-40X4	
32-18	105296001	1	テンビンダイイトカケ	THREAD GUIDE	
32-19	111112001	1	シタイトイトアンナイイタ	LOWER THREAD GUIDE PLATE	
32-20	105288001	1	シメネジ2.38	SCREW, SM2.38	
32-21	026030136	1	ヒラザガネコガタ3	WASHER, PLAIN S 3	
33	047501242	1	スプリングピンAW5	PIN, SPRING ROLL AW5	
34	100064005	2	シメネジ3.57	SCREW, SM3.57	
35	S40342051	1	シタイトテンビンネジツキH	LOWER THREAD TAKE-UP W/S, H	
35-1	014680422	2	アナトメネジ4.37クボミ	SET SCREW, SOCKET (CP) SM4.37	
36	105300101	1	シタイトオクリダシアンナイ	LOWER THREAD FEED BAR GUIDE	
37	147291001	1	ルーバイトアンナイダイ	LOOPER THREAD GUIDE BRACKET	
38	013760610	1	トメネジ5.95クボミ	SET SCREW, (CP) SM5.95	
39	111113101	1	イトキリアンナイイタ	THREAD TRIMMER GUIDE PLATE	
40	111114101	1	イトキリ	THREAD TRIMMER	
41	062670612	2	ナベコ357-40X6	SCREW, PAN SM3.57-40X6	
42	S40335051	1	ルーバガワフタRA	LOOPER COVER, RA	
43	S40338051	1	ルーバガワフタLA	LOOPER COVER, LA	
45	S40799051	2	ルーバガワフタトメバネ	SPRING	
48	062671412	1	ナベコ357-40X14	SCREW, PAN SM3.57-40X14	
8-1	105251009	1	<-5,-7用> シタイトタテアンナイクミ	<FOR "-5,-6"> INGLINED GUIDE TUBE ASSY	
22-1	S08987001	2	イトチヨウシボウ	THREAD TENSION CONTROL STUD	
23-1	021680202	2	ナツト2シユ4.37	NUT, 2 SM4.37	
24-1	144504001	4	イトアンナイサラ	THREAD GUIDE DISC	
25-1	S40324001	2	イトアンナイバネ	THREAD GUIDE SPRING	
26-1	155510001	2	イトチヨウシナツト	TENSION NUT	
8-2	111097009	1	<スタンダード,-6,-8用> シタイトタテアンナイクミ	<FOR STANDARD,-6 & -8> INGLINED GUIDE TUBE ASSY	
22-2	S08987001	3	イトチヨウシボウ	THREAD TENSION CONTROL STUD	
23-2	021680202	3	ナツト2シユ4.37	NUT, 2 SM4.37	
24-2	144504001	6	イトアンナイサラ	THREAD GUIDE DISC	
25-2	S40324001	3	イトアンナイバネ	THREAD GUIDE SPRING	
26-2	155510001	3	イトチヨウシナツト	TENSION NUT	
51	111072009	1	ミツメイトアンナイトリツケイタ	THREAD GUIDE SET PLATE	
52	062630412	2	ナベコ238-56X4	SCREW, PAN SM2.38-56X4	
53	111073001	2	サラネジ2.38	SCREW, FLAT SM2.38	
42-1	S40336051	1	<5/32X2, 3/16X2以外用> ルーバガワフタRB	<FOR WITHOUT "5/32X2, 3/16X2"> LOOPER COVER, RB	
43-1	S40339051	1	ルーバガワフタLB	LOOPER COVER, LB	
42-2	S40337051	1	<5/32X2, 3/16X2用> ルーバガワフタRC	<FOR "5/32X2, 3/16X2"> LOOPER COVER, RC	
43-2	S40340051	1	ルーバガワフタLC	LOOPER COVER, LC	

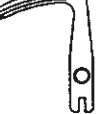
927 仕様別部品一覧表 / DIFFERENT PARTS LIST / ZUBEHÖRLISTE /
LISTE DES PIÈCES ACCESSOIRES / LISTA DE PIEZAS ACCESORIAS

参照番号 Ref.No.	品名 Name of part	薄物用 / Thin materials		中厚物用 / Medium materials		
		4.8mm [3/16]	6.4mm [1/4]	3.2mm [1/8]	4.0mm [5/32]	4.8mm [3/16]
G-1	ハリダキネジツキ Needle clamp with screw	 183954-001	 183978-001	 183953-001	 183951-001	 183954-001
G-2	ハリ / Needle 針数 (本) No. of needles	TVX64NY#12 (2) S36861-012	←	TVX64NY#14 (2) S36861-014	←	←
G-3	ハリイタ Needle plate	 S05946-101	 S11508-101	 S40371-001	 S40373-001	 S05946-101
G-5	オサエクミ Presser foot assy	 S40355-001	 S40363-001	 S40367-001	 S40365-001	 S40355-001
G-7	オクリバ Feed dog	 S40369-001	 S40370-001	 S40372-001	←	 S40369-001
G-10	ハリウケ Needle guard	 S06310-001	 148973-001	 S06310-001	←	←
G-13	ラッパークミ Lapper assy	 101494-001	 S09679-001	 101488-001	 101949-001	 101497-001
G-20-1	ルーパーS Looper (S)	 S40391-001	 S40393-001	 S40389-001	←	 S40391-001
G-20-2	ルーパーL Looper (L)	 S40392-001	 S40394-001	 S40390-001	←	 S40392-001

928 仕様別部品一覧表 / DIFFERENT PARTS LIST / ZUBEHÖRLISTE /
LISTE DES PIÈCES ACCESSOIRES / LISTA DE PIEZAS ACCESORIAS

参照番号 Ref.No.	厚物用 / Heavy materials					- 5 厚物 / Heavy materials
	2.8mmx2 [7/64x2]	3.2mmx2 [1/8x2]	3.2mmx2 [1/8x2]	4.0mmx2 [5/32x2]	4.8mmx2 [3/16x2]	4.8mm [3/16]
G-1 ハリダキ ネジツキ Needle clamp with screw	 183952-001	 181716-001	←	 181723-001	 181722-001	 183954-001
G-2 針・針数 (本) Needle No. of needles	TVX5#130 (3) S43401-021	←	←	←	←	TVX5#130 (2) S43401-021
G-3 ハリイタ Needle plate	 S40790-001	 S13042-001	←	 S40787-001	 S40783-001	 159583-001
G-5 オサエクミ Presser foot assy	 S40788-001	 S40386-001	←	 S40785-001	 S40781-001	 159584-201
G-7 オクリバ Feed dog	 S13045-101	←	←	 S40784-001	←	 159588-001
G-14 ラッパー クミ Lapper assy	 111171-001	 101561-001	 101564-001	 111177-001	 111183-001	 159609-001
G-18-1 ルーバーS Looper (S)	 S40375-001	←	←	 S40395-001	←	 S40375-001
G-18-2 ルーバーM Looper (M)	 S40376-001	←	←	←	←	—
G-18-3 ルーバーL Looper (L)	 S40377-001	←	←	 S40396-001	←	 S40377-001





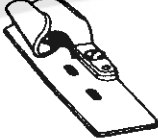
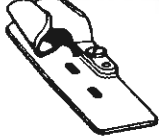

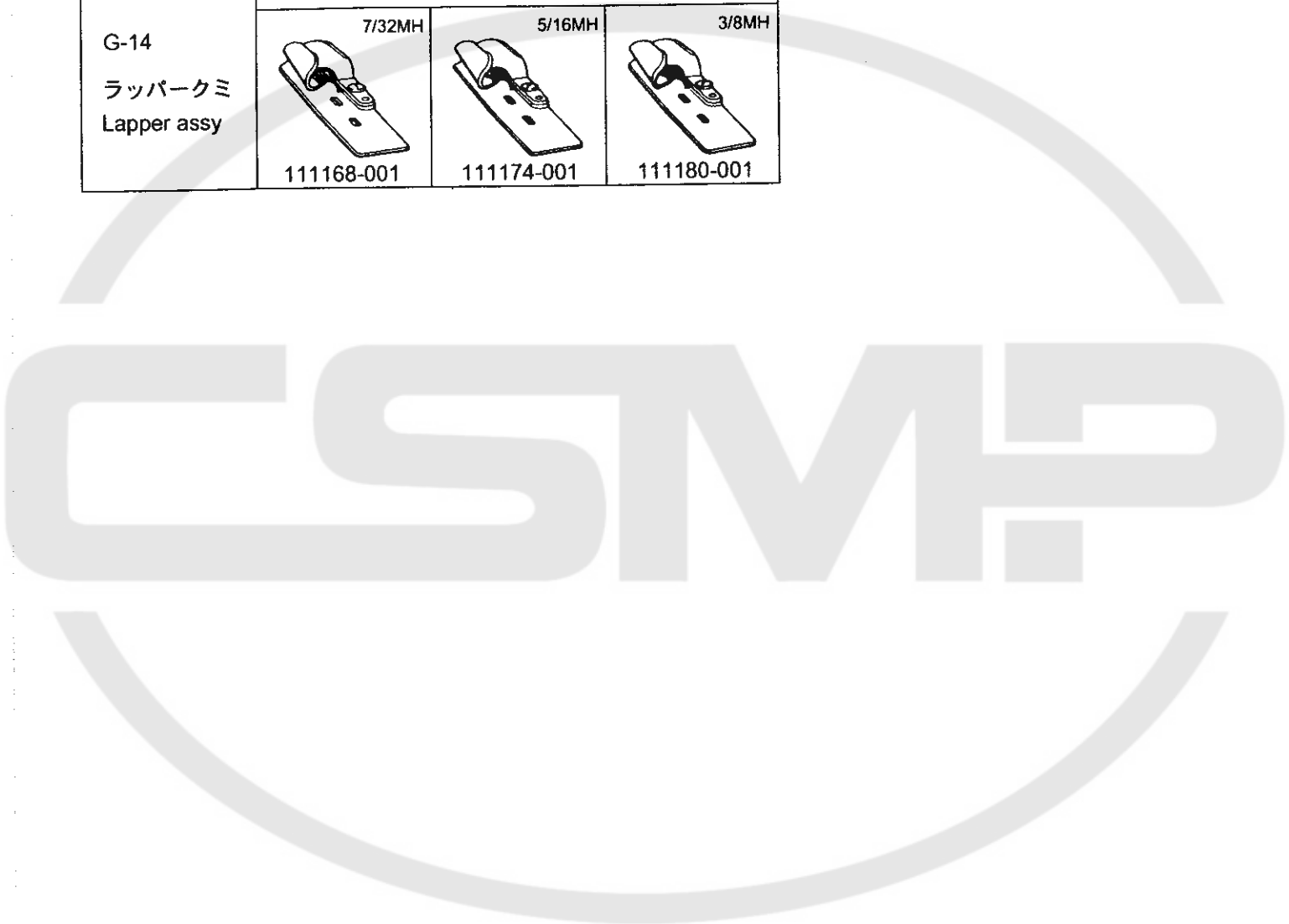







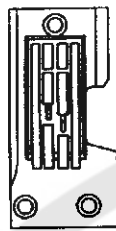

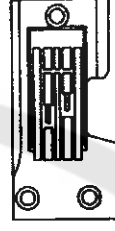
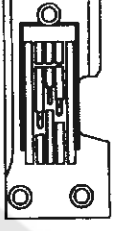

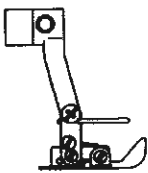
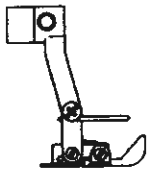
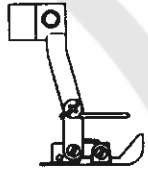









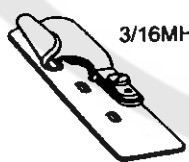
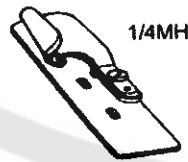
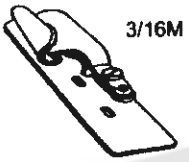
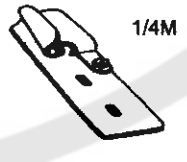
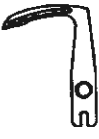

928 オプション部品 / OPTION PARTS LIST / SONDERZUBEHÖR /
 PIECES EN OPTION / PIEZAS OPCONALES

G-5 オサエクミ Presser foot assy	厚物用 / Heavy materials 3.2mmx2 [1/8x2]
	 S13043-101

G-14 ラッパークミ Lapper assy	中厚物用 / Medium materials		
	7/32MH  111168-001	5/16MH  111174-001	3/8MH  111180-001























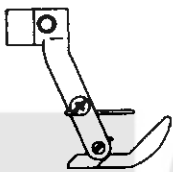
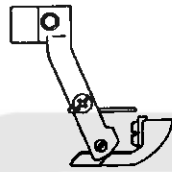
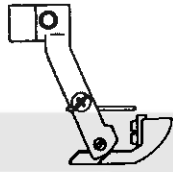
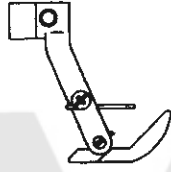
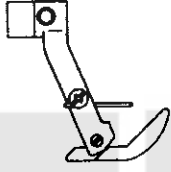
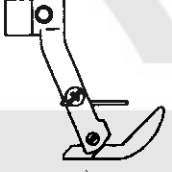

927 仕様別部品一覧表 / DIFFERENT PARTS LIST / ZUBEHÖRLISTE /
LISTE DES PIÈCES ACCESSOIRES / LISTA DE PIEZAS ACCESORIAS

参照番号 Ref.No.	中厚物用 / Medium materials			- 7 薄物用 / Thin materials			- 8
	4.8mm [3/16] 固定針受け / Fixed N. Guard	6.4mm [1/4]	6.4mm [1/4] 固定針受け / Fixed N. Guard	4.8mm [3/16]	6.4mm [1/4]	3.2mmx2 [1/8x2]	
G-1 ハリダキ ネジツキ Needle clamp with screw	 183954-001	 183978-001	←	 183954-001	 183978-001	 S16500-001	
G-2 ハリ / Needle 針数 (本) No. of needles	TVX64NY#14 (2) S36861-014	TVX64NY#16 (2) S36861-016	←	TVX64NY#11PSU (2) S36861-031	←	TVX64NY#11PSU (3) S36861-031	
G-3 ハリイタ Needle plate	 S05946-101	 S11508-101	←	 S06318-101	 S09672-101	 S16475-101	
G-5 オサエクミ Presser foot assy	 101491-101	 106160-101	←	 S06303-101	 S09673-101	 S16477-101	
G-7 オクリバ Feed dog	 S05947-001	 S40370-001		 S11509-001	 S06319-101	 S09678-001	 S16476-001
G-10 ハリウケ Needle guard	 105302-001	 148973-001		 106170-001	 S06310-001	 148973-001	 S16482-001
G-13 ラッパーギ Lapper assy	 101497-001	 101561-001	←	 101494-001	 S09679-001	←	
G-20-1 ルーバーS Looper (S)	 S40391-001	 S40393-001	←	 S40391-001	 S40393-001	(S) S40375-001	
G-20-2 ルーバーL Looper (L)	 S40392-001	 S40394-001	←	 S40392-001	 S40394-001	(M) S40376-001	

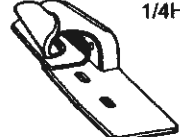
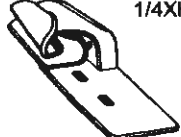
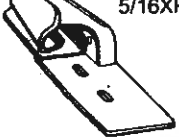
928 仕様別部品一覧表 / DIFFERENT PARTS LIST / ZUBEHÖRLISTE /
LISTE DES PIÈCES ACCESSOIRES / LISTA DE PIEZAS ACCESORIAS

参照番号 Ref.No.	- 5					- 6		- 7
	デニム用 / Extra heavy materials							厚物 / Heavy materials
	6.4mm [1/4]	3.2mmx2 [1/8x2] 段差 1.0 / Height Difference 1.0	3.2mmx2 [1/8x2] 段差 1.9 / Height Difference 1.9	4.0mmx2 [5/32x2]	4.8mmx2 [3/16x2]	4.8mm [3/16]		
G-1 ハリダキ ネジツキ Needle clamp with screw	 183978-001	 181716-001	←	 181723-001	 181722-001	 183954-001		
G-2 針・針数 (本) Needle No. of needles	TVX5#140 (2) S43401-022	TVX5#140 (3) S43401-022	←	←	←	TVX5#130 (2) S43401-021		
G-3 ハリイタ Needle plate	 147867-001	 S18086-001	 148864-001	 148944-001	 148927-001	 159614-001		
G-5 オサエクミ Presser foot assy	 147868-201	 S18081-201	 148865-201	 148945-201	 148928-201	 159615-101		
G-7 オクリバ Feed dog	 148971-001	 S18084-101	 148867-101	 148932-101	←	 159616-001		
G-14 ラッパー クミ Lapper assy	 147302-001	←	←	 148951-001	 148936-001	 159609-001		
G-18-1 ルーバー-S Looper (S)	 S40375-001	←	←	 S40395-001	←	 S40375-001		
G-18-2 ルーバー-M Looper (M)	／	 S40376-001	←	←	←	／		
G-18-3 ルーバー-L Looper (L)	 S40377-001	←	←	 S40396-001	←	 S40377-001		

928 仕様別部品一覧表 / DIFFERENT PARTS LIST / ZUBEHÖRLISTE /
LISTE DES PIÈCES ACCESSOIRES / LISTA DE PIEZAS ACCESORIAS

参照番号 Ref.No.	- 7		- 8			
	デニム / Extra heavy	厚物 / Heavy materials	デニム用 / Extra heavy materials			
	6.4mm [1/4]	3.2mmx2 [1/8x2] 段差 0 / Height Difference 0	3.2mmx2 [1/8x2] 段差 1.0 / Height Difference 1.0	3.2mmx2 [1/8x2] 段差 1.9 / Height Difference 1.9	4.0mmx2 [5/32x2]	4.8mmx2 [3/16x2]
G-1 ハリダキ ネジツキ Needle clamp with screw	 183978-001	 181716-001	←	←	 181723-001	 181722-001
G-2 針・針数(本) Needle No. of needles	TVX5#140 (2) S43401-022	TVX5#130 (3) S43401-021	TVX5#140 (3) S43401-022	←	←	←
G-3 ハリイタ Needle plate	 150666-001	 156175-001	 S01634-001	 150667-001	 151486-001	 151478-001
G-5 オサエクミ Presser foot assy	 150668-101	 156179-101	 S01632-101	 150672-101	 151487-101	 151479-101
G-7 オクリバ Feed dog	 150673-001	 156182-101	 S01635-101	 150675-101	 151483-101	←
G-14 ラッパー クミ Lapper assy	 147302-001	 101564-001	 147302-001	←	 148951-001	 148936-001
G-18-1 ルーバーS Looper (S)	 S40375-001	←	←	←	 S40395-001	←
G-18-2 ルーバーM Looper (M)	／	 S40376-001	←	←	←	←
G-18-3 ルーバーL Looper (L)	 S40377-001	←	←	←	 S40396-001	←

G4 .ゲージ関係 (928 "-5") / Gauge parts (928 "-5") / Lehren (928 "-5")
 / Pièces du jauge (928 "-5") / Piezas de calibradores (928 "-5")

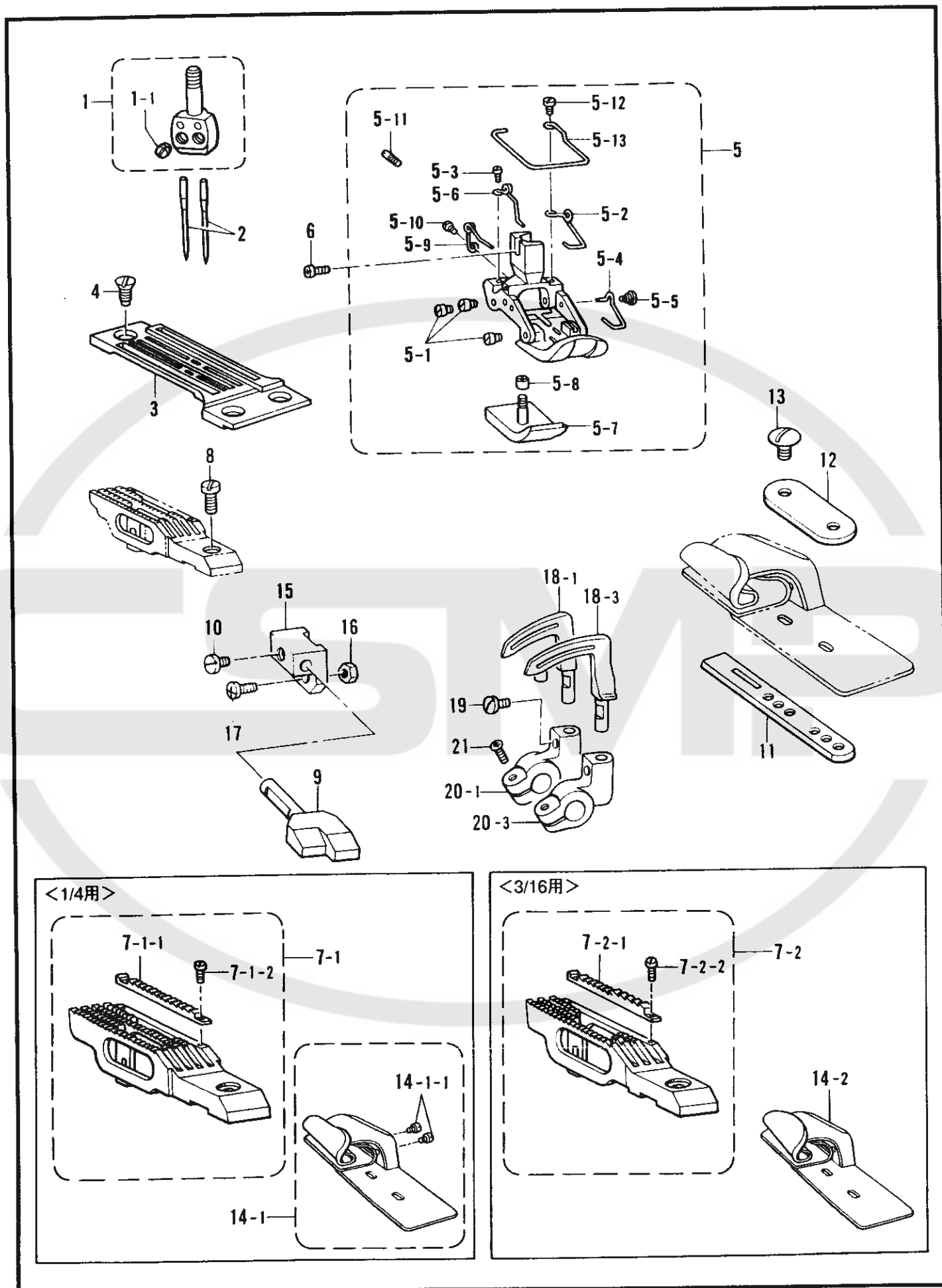

G4. ゲージ関係 (928 "-5") / Gauge parts (928 "-5") / Lehren (928 "-5")
 / Pièces du jauge (928 "-5") / Piezas de calibradores (928 "-5")

REF.NO.	CODE	Q'TY	ヒンメイ	NAME OF PARTS	RM
1	※	1	ハリダキネジツキ	NEEDLE CLAMP ASSY W/S	
1-1	103408002	2	トメネジ4.37	SET SCREW, SM4.37	
2	※	3	ミシンハリTVX5	NEEDLE, TVX5	
3	※	1	ハリイタ	NEEDLE PLATE	
4	100032004	3	サラネジ4.37	SCREW, FLAT SM4.37	
5	※	1	オサエクミ	PRESSER FOOT ASSY	
5-1	147871001	6	オサエヒン	PIN	
5-2	147872001	1	オサエMバネ	SPRING	
5-3	501295001	1	シメネジ2.38X3.5	SCREW, SM2.38X3.5	
5-4	147890001	1	オサエFバネ	SPRING	
5-5	147932001	1	ダンネジ2.38	SHOULDER SCREW, SM2.38	
5-6	147875001	1	オサエBLバネ	SPRING	
5-8	147877001	1	ツマミナツト3.18	NUT, SM3.18	
5-9	147878001	1	オサエBSバネ	SPRING	
5-10	062660512	1	ナベコネジ318-40X5	SCREW, PAN SM3.18-40X5	
5-11	147879001	1	トメネジ3.18	SET SCREW, SM3.18	
5-12	111105002	1	シメネジ2.38	SCREW, SM2.38	
5-13	151572101	1	フィンガーガード	FINGER GUARD	
6	060670812	1	バインド357-40X8	SCREW, BIND SM3.57-40X8	
8	105173004	1	シメネジ4.76	SCREW, SM4.76	
9	148973001	1	ハリウケ-5	NEEDLE GUARD, -5	
10	111443003	1	マルヒラトメネジ3.57	SET SCREW, SM3.57	
11	S40399001	1	ラツパーアンナイイタ	LAPPER GUIDE PLATE	
12	105129001	1	アンナイイタザガネ	LAPPER GUIDE PLATE WASHER	
13	105130001	2	シメネジ3.57	SCREW, SM3.57	
15	148876001	1	ハリウケトリツケダイ	NEEDLE GUARD BRACKET	
16	021670102	1	ナツト1シユ3.57	NUT, 1 SM3.57	
17	062671012	1	ナベコ357-40X10	SCREW, PAN SM3.57-40X10	
18-1	S40375001	1	ルーバS1/8X2-6	LOPPER, S 1/8"X2-6	
18-3	S40377001	1	ルーバL1/8X2-6	LOPPER, L 1/8"X2-6	
19	111443003	3	マルヒラトメネジ3.57	SET SCREW, SM3.57	
20-1	S40378051	1	ルーバホルダS	LOPPER HOLDER, S	
20-3	S40380051	1	ルーバホルダL	LOPPER HOLDER, L	
21	062671012	2	ナベコ357-40X10	SCREW, PAN SM3.57-40X10	
<hr/>					
5-7	147876001	1	<1/4用> オサエBS	<FOR"1/4"> PRESSER FOOT, BS	
7-1	148971001	1	オクリバ1/4クミ	FEED DOG ASSY, 1/4"	
7-1-1	147307001	1	トリツケバ	SUB FEED DOG	
7-1-2	147880001	2	シメネジ1.98	SCREW, SM1.98	
14-1	147302001	1	ラツパー1/4XHクミ	LAPPER ASSY, 1/4" XH	
14-1-1	122771001	2	シメネジ2.38	SCREW, SM2.38	
5-7	159587001	1	<3/16用> オサエBS3/18	<FOR"3/16"> PRESSER FOOT, BS 3/18"	
7-2	159588001	1	オクリバ3/16クミ	FEED DOG ASSY, 3/16"	
7-2-1	159590001	1	トリツケバ	SUB FEED DOG	
7-2-2	147880001	2	シメネジ1.98	SCREW, SM1.98	
14-2	159609001	1	ラツパー3/16Hクミ	LAPPER ASSY, 3/16" H	

G5. ゲージ関係 (928 "-6") / Gauge parts (928 "-6") / Lehren (928 "-6")
 / Pièces du jauge (928 "-6") / Piezas de calibradores (928 "-6")

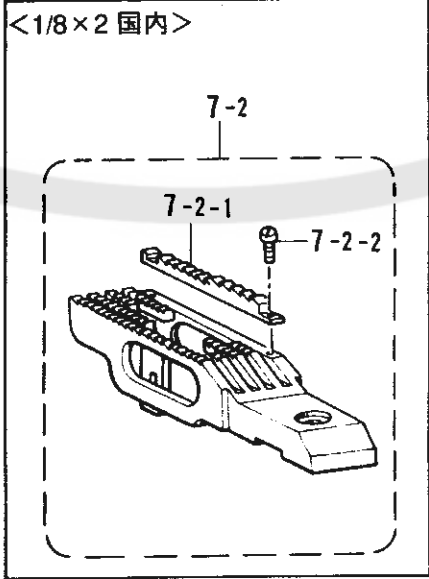
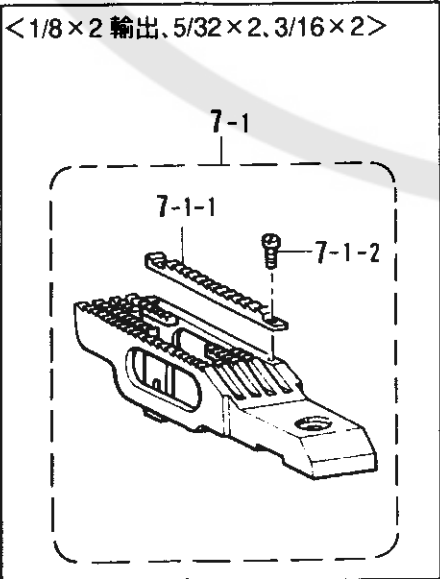
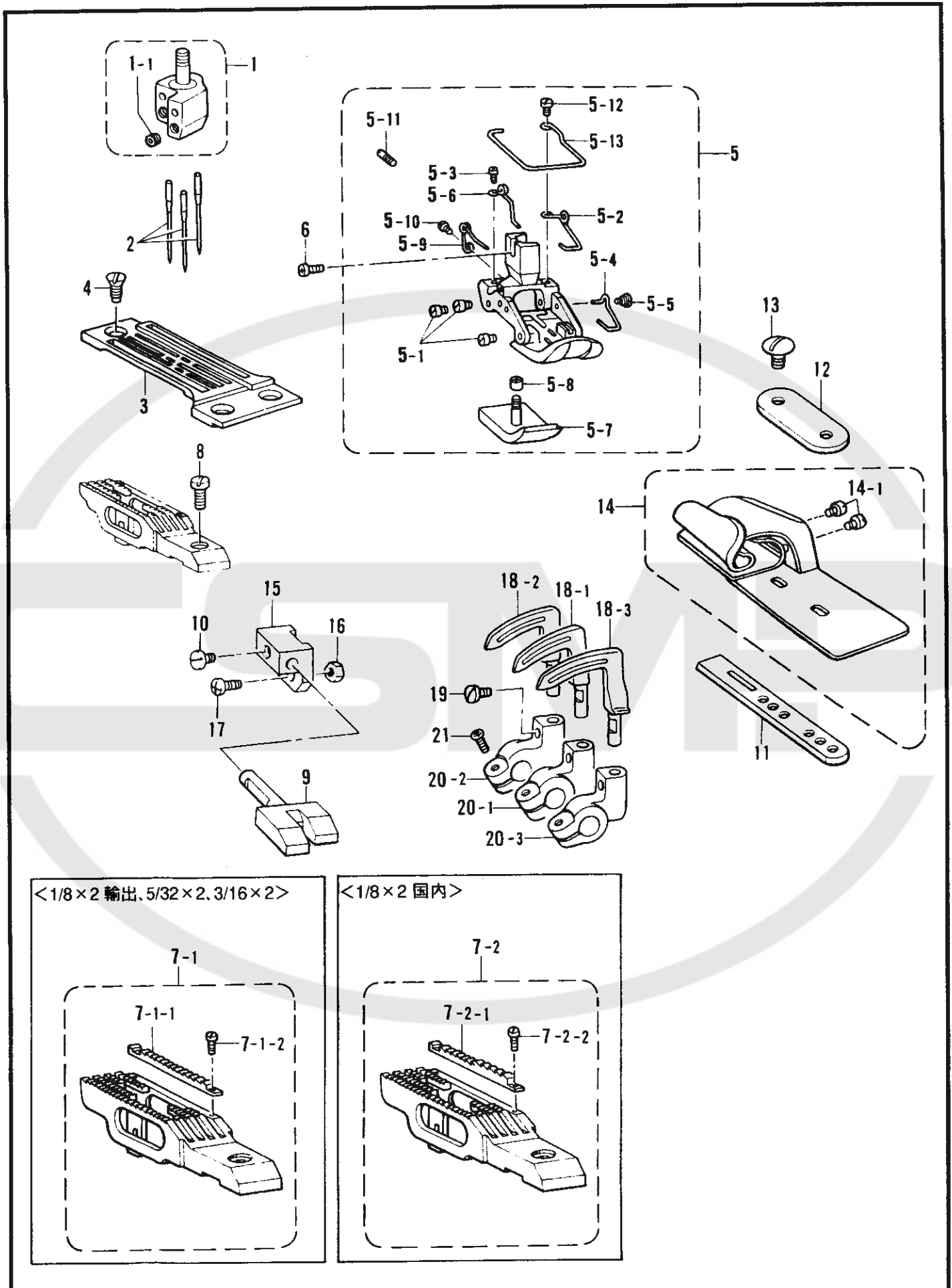

G5. ゲージ関係 (928 "-6") / Gauge parts (928 "-6") / Lehren (928 "-6")
 / Pièces du jauge (928 "-6") / Piezas de calibradores (928 "-6")

REF.NO.	CODE	Q'TY	ヒンメイ	NAME OF PARTS	RM
1	※	1	ハリダキクミ	NEEDLE CLAMP ASSY	
1-1	146427001	3	アナトメネジ3.18クボミ	SET SCREW, SOCKET (CP) SM3.18	
2	111128022	3	ミシンハリTVX5	NEEDLE, TVX5 (#22)	
3	※	1	ハリイタ	NEEDLE PLATE	
4	100032004	3	サラネジ4.37	SCREW, FLAT SM4.37	
5	※	1	オサエクミ	PRESSER FOOT ASSY	
5-1	147871001	6	オサエヒン	PIN	
5-2	147872001	1	オサエMバネ	SPRING	
5-3	S01295001	1	シメネジ2.38X3.5	SCREW, SM2.38X3.5	
5-4	147890001	1	オサエFバネ	SPRING	
5-5	147932001	1	ダンネジ2.38	SHOULDER SCREW, SM2.38	
5-6	147875001	1	オサエBLバネ	SPRING	
5-7	147876001	1	オサエBS	PRESSER FOOT, BS	
5-8	147877001	1	ツマミナツト3.18	NUT, SM3.18	
5-9	147878001	1	オサエBSバネ	SPRING	
5-10	062660512	1	ナベコネジ318-40X5	SCREW, PAN SM3.18-40X5	
5-11	147879001	1	トメネジ3.18	SET SCREW, SM3.18	
5-12	111105002	1	シメネジ2.38	SCREW, SM2.38	
5-13	151572101	1	フィンガーガード	FINGER GUARD	
6	060670812	1	バインド357-40X8	SCREW, BIND SM3.57-40X8	
8	105173004	1	シメネジ4.76	SCREW, SM4.76	
9	148875001	1	ハリウケ-6	NEEDLE GUARD, -6	
10	111443003	1	マルヒラトメネジ3.57	SET SCREW, SM3.57	
11	S40399001	1	ラツハーアンナイイタ	LAPPER GUIDE PLATE	
12	105129001	1	アンナイイタザガネ	LAPPER GUIDE PLATE WASHER	
13	105130001	2	シメネジ3.57	SCREW, SM3.57	
14	※	1	ラツパークミ	LAPPER ASSY	
14-1	122771001	2	シメネジ2.38	SCREW, SM2.38	
15	148876001	1	ハリウケトリツケダイ	NEEDLE GUARD BRACKET	
16	021670102	1	ナツト1シユ3.57	NUT, 1 SM3.57	
17	062671012	1	ナベコ357-40X10	SCREW, PAN SM3.57-40X10	
18-1	S40375001	1	ルーハS1/8X2-6	LOPPER, S 1/8"X2-6	
18-2	S40376001	1	ルーハM-6	LOPPER, M-6	
18-3	S40377001	1	ルーハL1/8X2-6	LOPPER, L 1/8"X2-6	
19	111443003	3	マルヒラトメネジ3.57	SET SCREW, SM3.57	
20-1	S40378051	1	ルーハホルダS	LOPPER HOLDER, S	
20-2	S40379051	1	ルーハホルダM	LOPPER HOLDER, M	
20-3	S40380051	1	ルーハホルダL	LOPPER HOLDER, L	
21	062671012	3	ナベコ357-40X10	SCREW, PAN SM3.57-40X10	
7-1	※	1	<1/8X2輸出用, 5/32X2,3/16X2用>	<FOR EXPORT "1/5X2" & 5/32X2,3/16X2>	
7-1-1	147307001	1	オクリバクミ	FEED DOG ASSY	
7-1-2	147880001	1	トリツケバ	SUB FEED DOG	
		2	シメネジ1.98	SCREW, SM1.98	
7-2	S18084101	1	<1/8X2国内用>	<FOR JAPAN ONLY>	
7-2-1	S01637001	1	オクリバ1/8X2クミD1	-----	
7-2-2	147880001	1	トリツケバ	-----	
		2	シメネジ1.98	-----	

G6 . ゲージ関係 (928 "-7") / Gauge parts (928 "-7") / Lehren (928 "-7")
 / Pièces du jauge (928 "-7") / Piezas de calibradores (928 "-7")

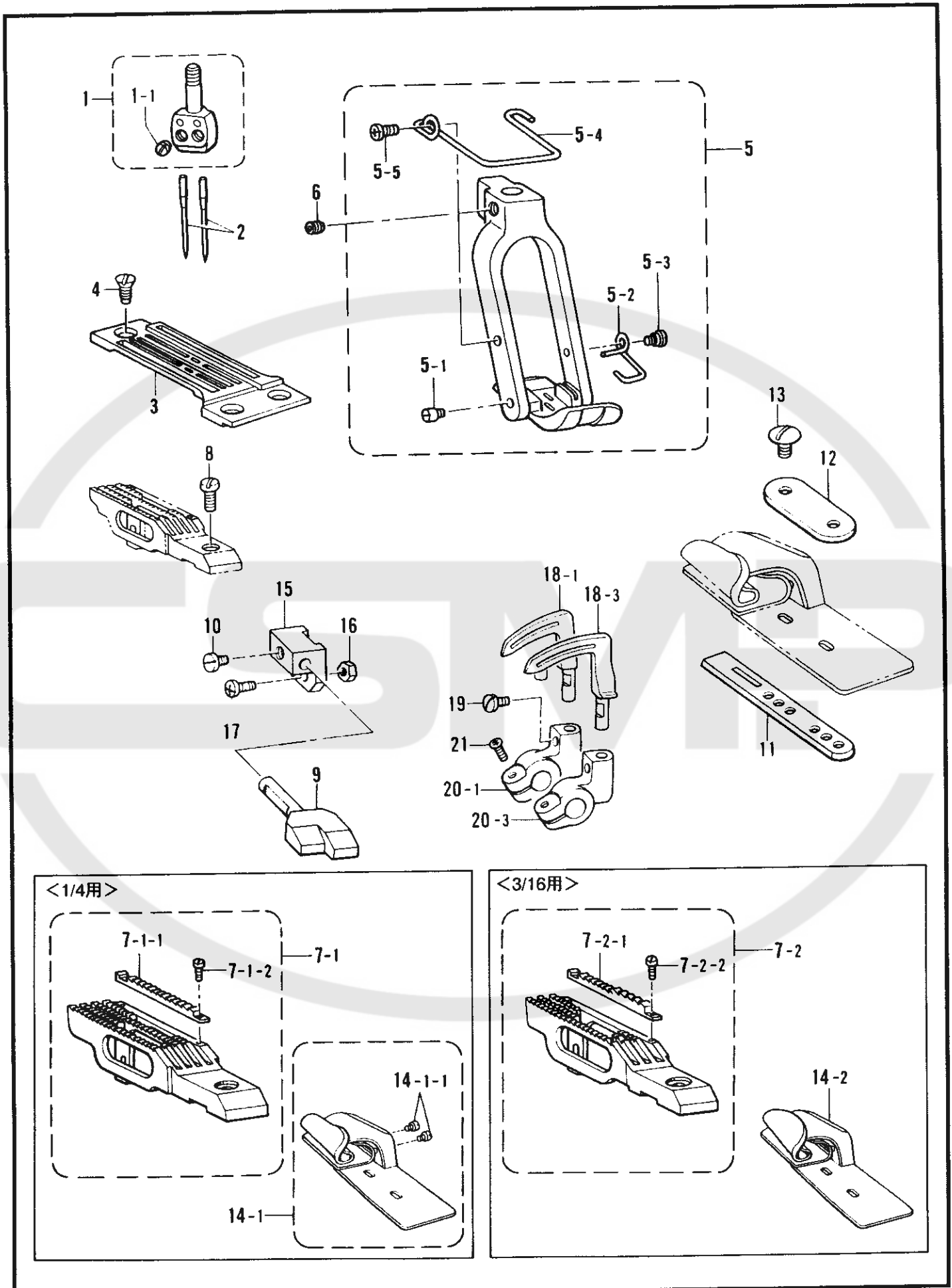

G6. ゲージ関係 (928 "-7") / Gauge parts (928 "-7") / Lehren (928 "-7")
 / Pièces du jauge (928 "-7") / Piezas de calibradores (928 "-7")

REF.NO.	CODE	Q'TY	ヒンメイ	NAME OF PARTS	RM
1	※	1	ハリダキネジツキ	NEEDLE CLAMP ASSY W/S	
1-1	103408002	2	トメネジ4.37	SET SCREW, SM4.37	
2	※	2	ミシンハリTVX5	NEEDLE, TVX5	
3	※	1	ハリイタ	NEEDLE PLATE	
4	100032004	3	サラネジ4.37	SCREW, FLAT SM4.37	
5	※	1	オサエクミ	PRESSER FOOT ASSY	
5-1	150670001	2	オサエピン	PIN	
5-2	150671001	1	オサエFバネ	SPRING	
5-3	147932001	1	ダンネジ2.38	SHOULDER SCREW, SM2.38	
5-4	156211101	1	フィンガーガード	FINGER GUARD	
5-5	060660512	1	バインド318-40X5	SCREW, BIND SM3.18-40X5	
6	014760622	1	アナトメネジ5.95	SET SCREW, SOCKET SM5.95	
8	105173004	1	シメネジ4.76	SCREW, SM4.76	
9	148973001	1	ハリウケ-5	NEEDLE GUARD, -5	
10	111443003	1	マルヒラトメネジ3.57	SET SCREW, SM3.57	
11	S40399001	1	ラツパーアンナイイタ	LAPPER GUIDE PLATE	
12	105129001	1	アンナイイタザガネ	LAPPER GUIDE PLATE WASHER	
13	105130001	2	シメネジ3.57	SCREW, SM3.57	
15	148876001	1	ハリウケトリツケダイ	NEEDLE GUARD BRACKET	
16	021670102	1	ナツト1シユ3.57	NUT, 1 SM3.57	
17	062671012	1	ナベコ357-40X10	SCREW, PAN SM3.57-40X10	
18-1	S40375001	1	ルーバS1/8X2-6	LOPPER, S 1/8"X2-6	
18-3	S40377001	1	ルーバL1/8X2-6	LOPPER, L 1/8"X2-6	
19	111443003	2	マルヒラトメネジ3.57	SET SCREW, SM3.57	
20-1	S40378051	1	ルーバホルダS	LOPPER HOLDER, S	
20-3	S40380051	1	ルーバホルダL	LOPPER HOLDER, L	
21	062671012	2	ナベコ357-40X10	SCREW, PAN SM3.57-40X10	
<hr/>					
7-1	150673001	1	<1/4用> オクリバ1/4-7クミ	<FOR "1/4"> FEED DOG ASSY, 1/4"-7	
7-1-1	147307001	1	トリツケバ	SUB FEED DOG	
7-1-2	147880001	2	シメネジ1.98	SCREW, SM1.98	
14-1	147302001	1	ラツパー1/4XHクミ	LAPPER ASSY, 1/4" XH	
14-1-1	122771001	2	シメネジ2.38	SCREW, SM2.38	
7-2	159616001	1	<3/16用> オクリバ3/16-7クミ	<FOR "3/16"> FEED DOG ASSY, 3/16"-7	
7-2-1	159590001	1	トリツケバ	SUB FEED DOG	
7-2-2	147880001	2	シメネジ1.98	SCREW, SM1.98	
14-2	159609001	1	ラツパー3/16Hクミ	LAPPER ASSY, 3/16" H	

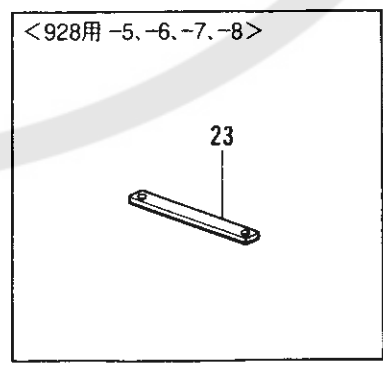
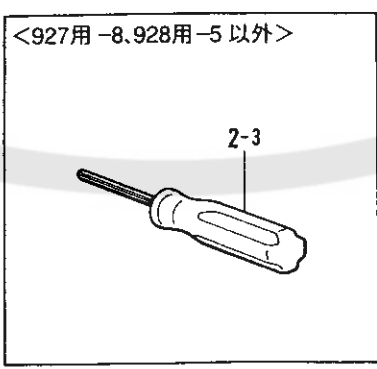
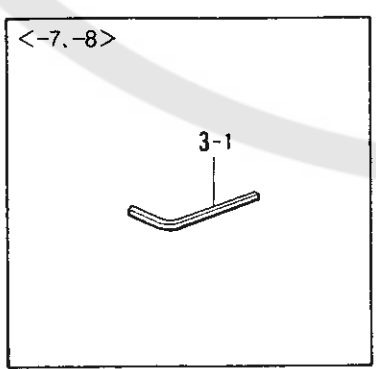
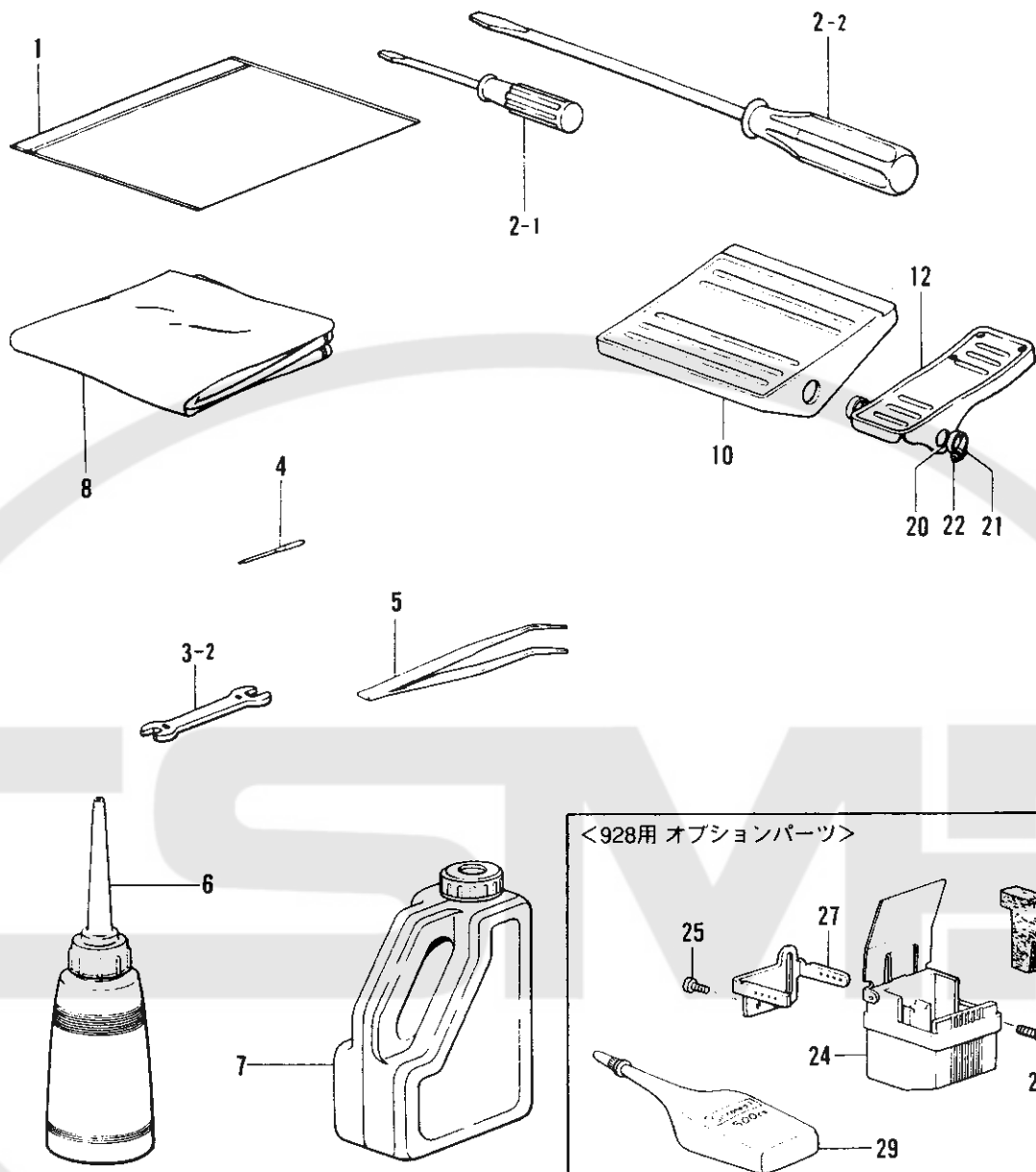

◎ 付属品の明細は変更することがあります。
 ◎ The details of included accessories are subject to change.
 ◎ Änderungen in der Aufstellung der Mitgelieferten
 Zubehöre sind vorbehalten.

◎ Les détails des accessoires inclus sont sujets à des changements.
 ◎ Los detalles de los accesorios incluidos pueden variar.

付属品関係 / Accessories / Zubehör / Accessoires / Accesorios

REF.NO.	CODE	Q'TY	ヒンメイ	NAME OF PARTS	RM
1	122991001	1	フソクヒンポリフクロ	ACCESSORY BAG	
2-1	105344001	1	ネジマワシ2.6X70	SCREW DRIVER, 2.6X70	
2-2	101572101	1	ネジマワシ5.5X190	SCREW DRIVER, 5.5X190	
3-2	100887001	1	スハナ8X9	WRENCH, 8X9	
5	117466000	1	ピンセット	PINCETTE	
6	114483002	1	ポリオイラークミ	OILER ASSY	
8	144228001	1	トウブカバー	HEAD COVER	
10	133636009	1	フミイタ	THREADLE PEDAL	
11	180827009	2	フミイタトメクミ	THREADLE PEDAL STOPPER ASSY	
11-1	151604001	4	トメネジ5.95	SET SCREW, SM5.95	
12	117437109	1	オサエアゲフミイタ	FOOT LIFTER PEDAL	
13	109656009	1	レンカンレバーL	CONNECTING LEVER, L	
14	100463001	2	カクボルト7.94	BOLT, SM7.94	
15	106062009	1	フミイタササエジク	THREADLE PEDAL SHAFT	
16	109657009	2	フミイタジクウケ	THREADLE PEDAL BRACKET	
17	0B1512502	4	+サラモク51X25	WOOD SCREW, FLAT M5.1X25	
18	105359001	2	レンカン	CONNECTING ROD	
19	181225001	1	レンカンダキクミ	CONNECTING ROD CLAMP ASSY	
20	116016001	2	ペタルトメ	PEDAL STOPPER	
21	021400106	2	ナツト1シユ4	NUT, 1 M4	
22	062401406	2	ナベコ4X14	SCREW, PAN M4X14	
2-3	S01943001	1	<927用-8,928用-5以外> 6カクボウネジマワシ1.6	<FOR 927 "-8", WITHOUT 928 "-5"> SCREW DRIVER, 1.6	
3-1	142721001	1	<-7,-8用> 6カクボウスハナ3	<FOR "-7,-8"> HEXAGONAL WRENCH, 3	
4	※	8	<927用> ミシンハリTVX64NY	<FOR 927> NEEDLE, TVX64NY	
4	※	8	<928用> ミシンハリTVX5	<FOR 928> NEEDLE, TVX5	
23	148298001	1	<928用 -5, -6, -7, -8> スペーサ	<FOR 928 "-5, -6, -7 & -8"> SPACER	
24	S08758009	1	" オプション部品 "	" OPTIN PARTS "	
25	575456001	2	<928用> +ナベPタイト3X10	<FOR 928> TAPTITE, PAN P M3X10	
26	S08761100	1	ハリイトレイキヤクフエルト	FELT	
27	S08969101	1	チユカナイトアンナイ	THREAD GUIDE	
28	060680712	2	バインド437-40X7	SCREW, BIND SM4.37X7	
29	S06704001	1	シリコンオイル	SILICONE OIL	