

**GLOBAL**

**FB 9500 SERIES**

**CSTMP**

**spare parts &  
instruction manual**

## 1. MAIN SPECIFICATIONS AND APPLICATIONS

MODEL	NEEDLE TYPE	STITCH LENGTH (mm)	NEEDLE	THREAD	NEEDLE GAUGE (mm)	FOOT LIFT (mm)	NEEDLE BAR STROKE(mm)	SPEED (s. p. m.)
FB 9503	70 -90	1.8 -3.3	3	5	4. 8, 5. 6, 6. 6. 4	6	31	4000

MODEL	APPLICATIONS
FB 9503	Available to perform cover stitching on cotton jersey and other similar garments.

## 2. PRECAUTION

### 1. Examination

Though every machine is confirmed by strict inspection and test before leaving the factory, the machine parts may be loose or deformed after long distance transportation with jolt. A thorough examination must be performed after cleaning the machine. Turn the balance wheel to see if there is running obstruction, parts collision, uneven resistance or abnormal noise. If these exist, adjustment must be made accordingly before run -in operation.

### 2. Lubrication

Oil to be used: Use special 18#sewing machine oil as lubricant. Feeding of oil: Because oil will have been drained completely from machine, it must be filled before run -in operation . When refilling oil, first screw out oil check window(A)

by special wrench and use T18# sewing machine oil only. At the meantime please observe oil level gauge(B) to make sure that the oil level does not exceed the red line. (see fig. 1 ) Exchange of oil: To keep the machine longer life, oil should be changed completely after the initial use about 200 hours, then change oil 2 or 3 times yearly. Remove drain screw(D) and drain oil. (fig1)

3. When the machine head is sparated from the oil reservoir for examination, put the filter inside the arm so that the head can be placed on a flat bed: Turn the wrench down to level position before examination. After examination, take the filter at the original position and turn the wrench up to vertical position to supply oil normally. ( fig. 1 )

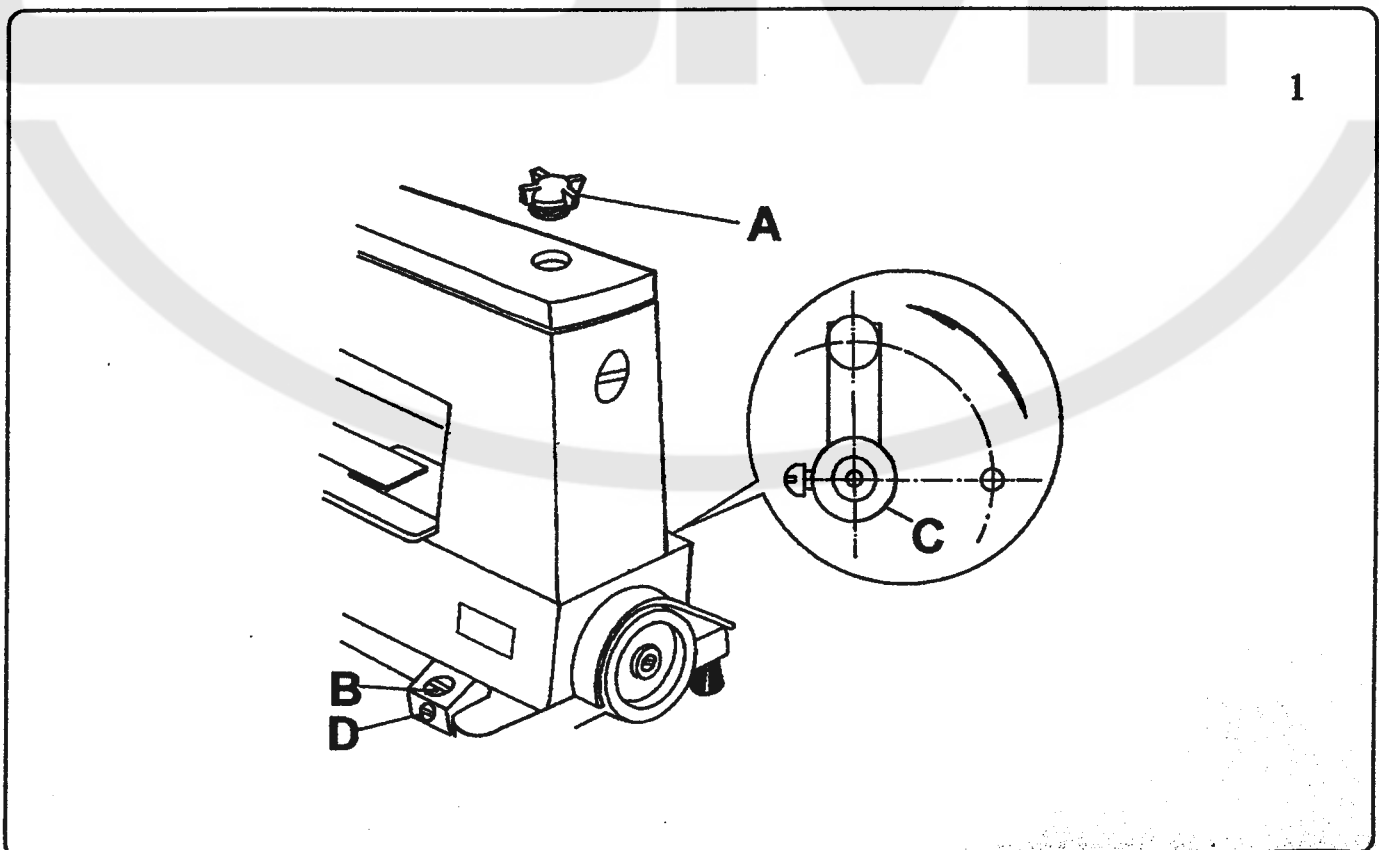

### 3. SPEED FOR RUN –IN AND SEWING OPERATION

#### 1) Run –in

Operate the machine idle at lower speed. If running well, pick up the speed to 3000 s. p. m. . and continue to run idle for a few more minutes until the machine maintains sound performance after rechecking it.

#### 2) Sewing operation

The built –in auto –lubrication system enables the machine to sew at high speed, but to prolong the service life the initial sewing speed for a new machine must not exceed 3000 s. p. m. See that machine pulley (A) is rotating in the direction shown as the arrow indicates. (fig 2)

If the motor is rotating in the reverse direction, turn off the power, made the plug a 180 –degree turn and inset it in the socket on the motor again to obtain the correct direction.

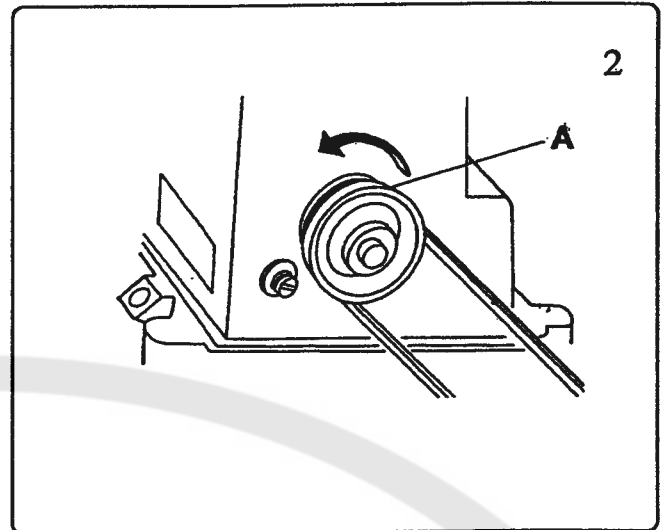

### 4. STITCH LENGTH ADJUSTMENT

#### 1) Loosen Nut F(leftwise screw).

2) Loosen Screw(G) . Turn the screw in "A" direction for longer stitch length and in "B" direction for shorter stitch length.

3) When the required stitch length is obtained, tighten nut (F). (fig. 3)

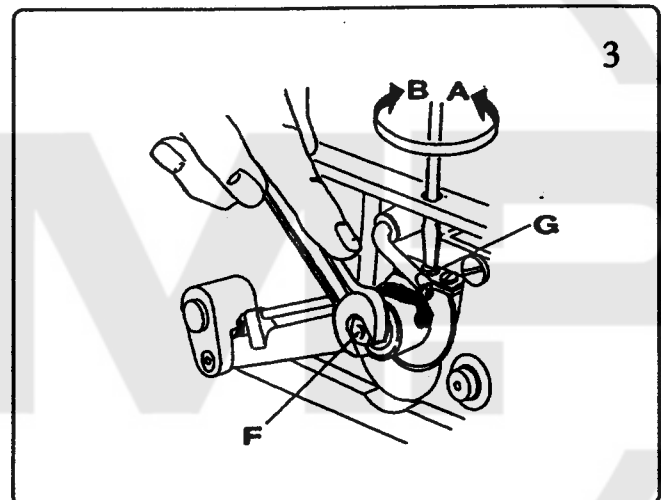

### 5. DIFFERENTIAL FEED ADJUSTMENT

FB 9503 is fitted with differential feed mechanism which is suited to perform sewing and pleating on woolen, heavy weight or elastic sewing materials without any deformation.

1) Loosen Screw(F) and turn it in "A" direction for more differential feed or in "B" direction for less differential feed.

2) When the required differential feed is obtained, tighten Screw(F). (fig4)

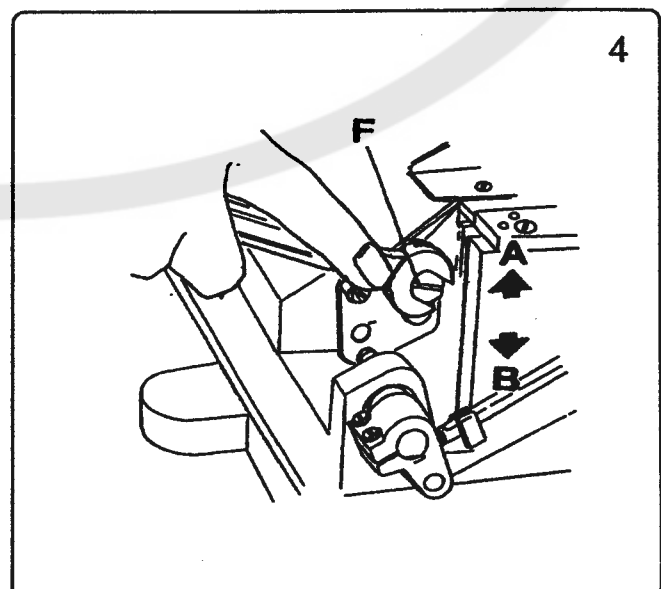

## 6. INSTALLATION AND ADJUSTMENT OF LOOPER

Timing of needle with looper moving right/left: when needle bar is going up, looper must move to left from its right end. when the looper begins to move towards left, needle must be going up. That is to say, when needle is at the highest and the looper is at left end. When needle is at the lowest and looper is at right end. If this can not be obtained, loosen the two screws (A) of eccentric cam and turn the balance wheel to regulate as eccentric cam does not move. (fig. 5)

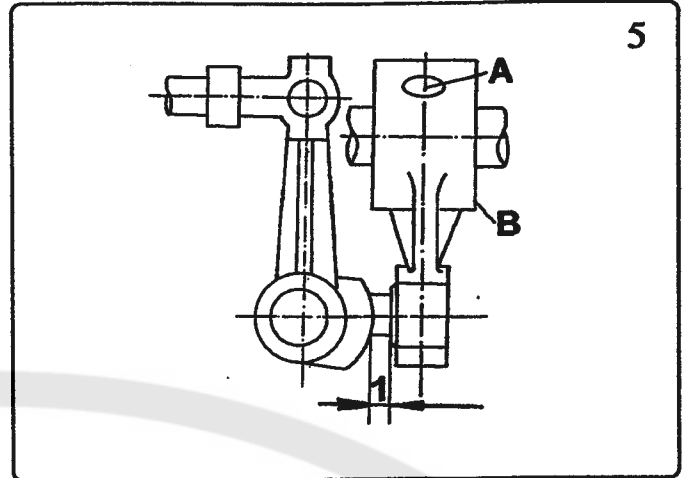

Make both line of shaft and center of screw(A) be aligned in order to arrive the certainly interval. Else, it will change the working route. (fig. 6)

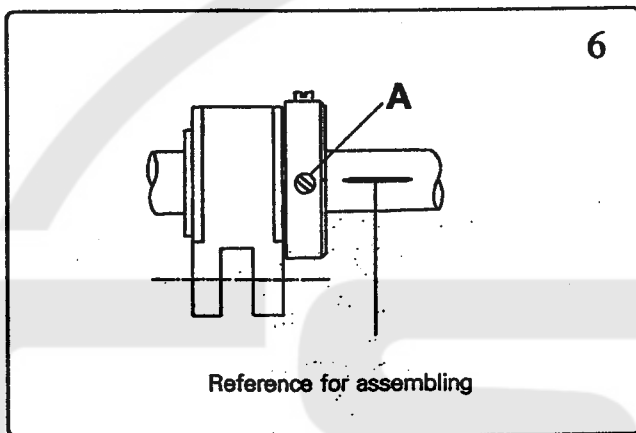

Relative positioning of needle and looper: To obtain distance  $0 - 0.05\text{mm}$  (fig. 7) . which represents the distance between the point of the looper and the needle notch during its stroke from right to left, slacken screw (F) in fig. 22.

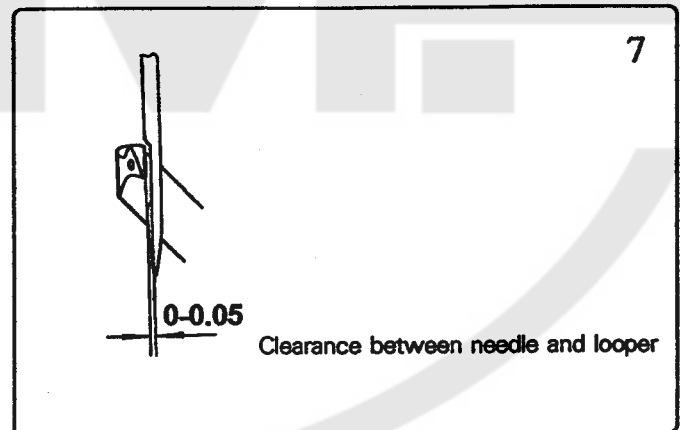

Loosen screw (G) (see. fig. 22 of part12), to obtain distance  $2.5\text{mm}$  between of looper and right needle as the needle is at the lowest (fig. 8) . When the distance is obtained, tighten screw (G).

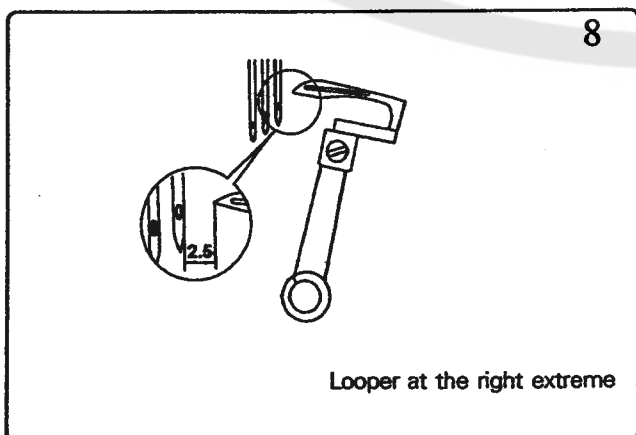

## 7. ASSEMBLING REFERENCE

The right needle height can be adjusted ( after having removed machine arm cover ), then slackening nut A and moving link rod B downwards in order to increase the link rod or upward to it. ( adjustment hight 13 mm )

Replacing needle should be made correctly with the scarf facing rightly backward as shown in the illustration (fig. 10 )

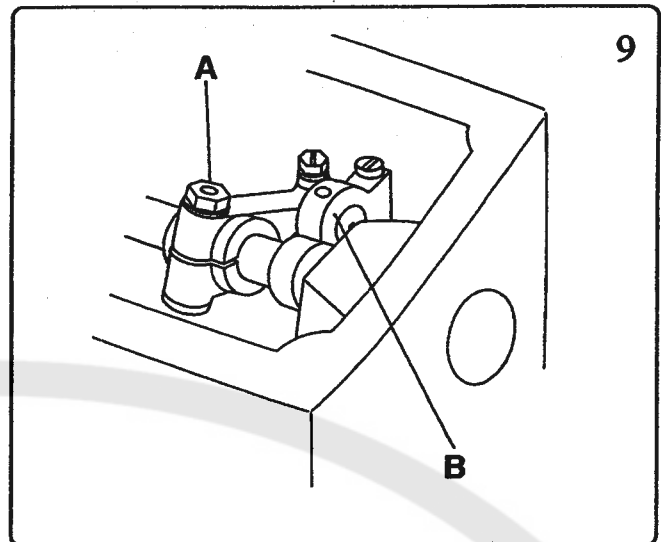

Needle bar at the highest (fig. 11)

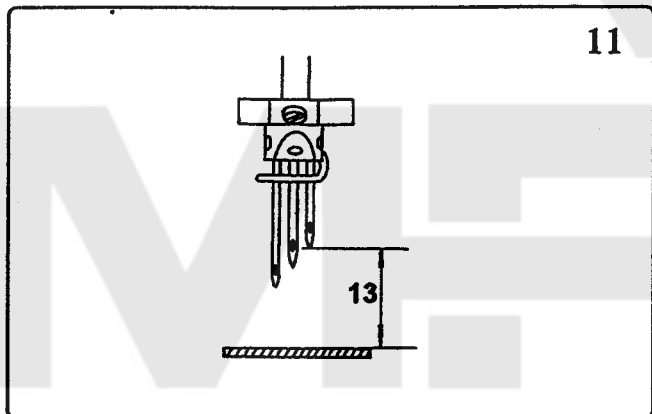
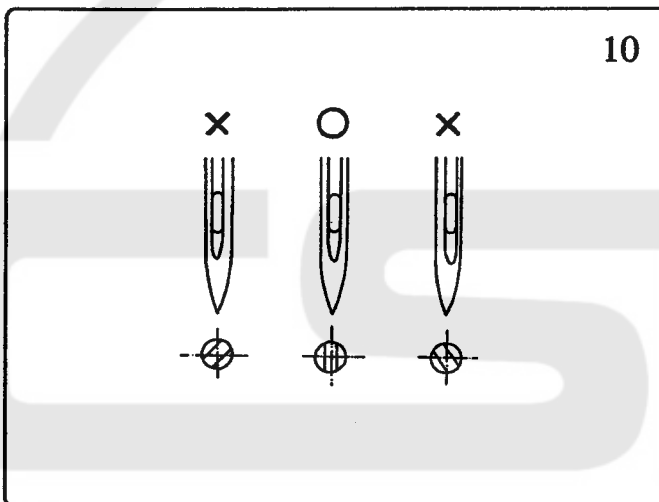

## 8. ADJUSTING INTERMITTENT NEEDLE THREAD TAKE - UP

This machine is an adjustable stroke thread take - up with which seams having more or less elasticity can be obtained, by increasing or decreasing the size of the needle thread loops, Its stroke can be adjusted(after having removed machine arm cover) by slackening nut(A) (fig. 12) and moving pin(B) downwards in order to increase the stoke or upwards to decrease it. The stroke thread must be decreased when the stoke increases.

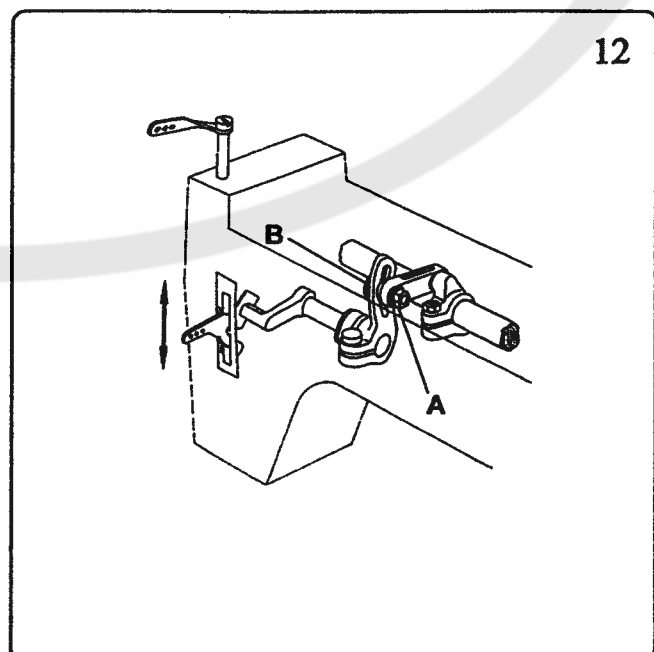

For general thread, when the needle bar thread eyelet (A) is at the lowest, the position of covering thread guard (B) is in fig. 13 shown. When using elasticity thread, move the covering thread guard (B) upward to be of benefit for forming loop.

When adjusting the amount of thread take-up move the thread eyelet bar, upper the thread eyelet bar (C) to get plenty of thread running and otherwise to get little of thread running. (fig. 14)

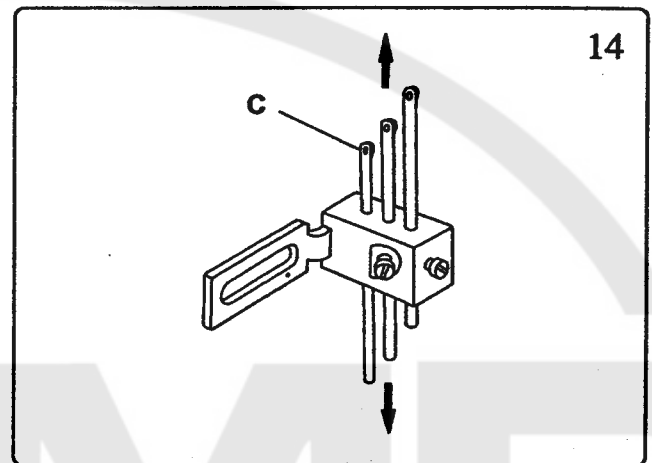
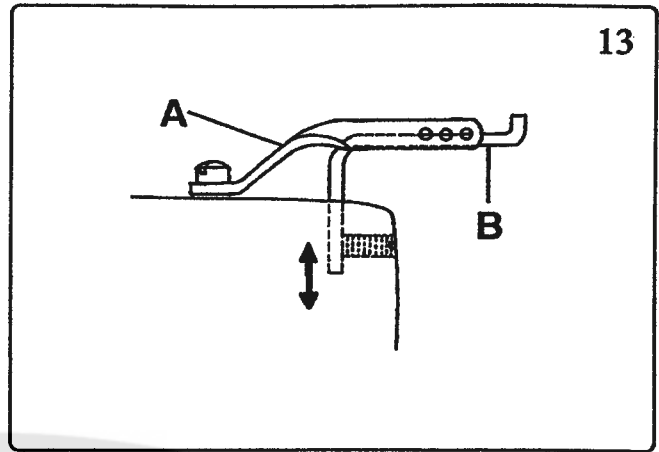

## 9. ADJUSTING LOOPER THREAD TAKE-UP CAM

The two thread take-up cam discs (A) must be perfectly centered with upper thread guide (B) and lower thread guide (D) (fig. 15). To make the adjustment, slacken screw (C) on cam hub. Slide cam in the correct position when the looper starts its stroke towards the right, it must tension its thread.

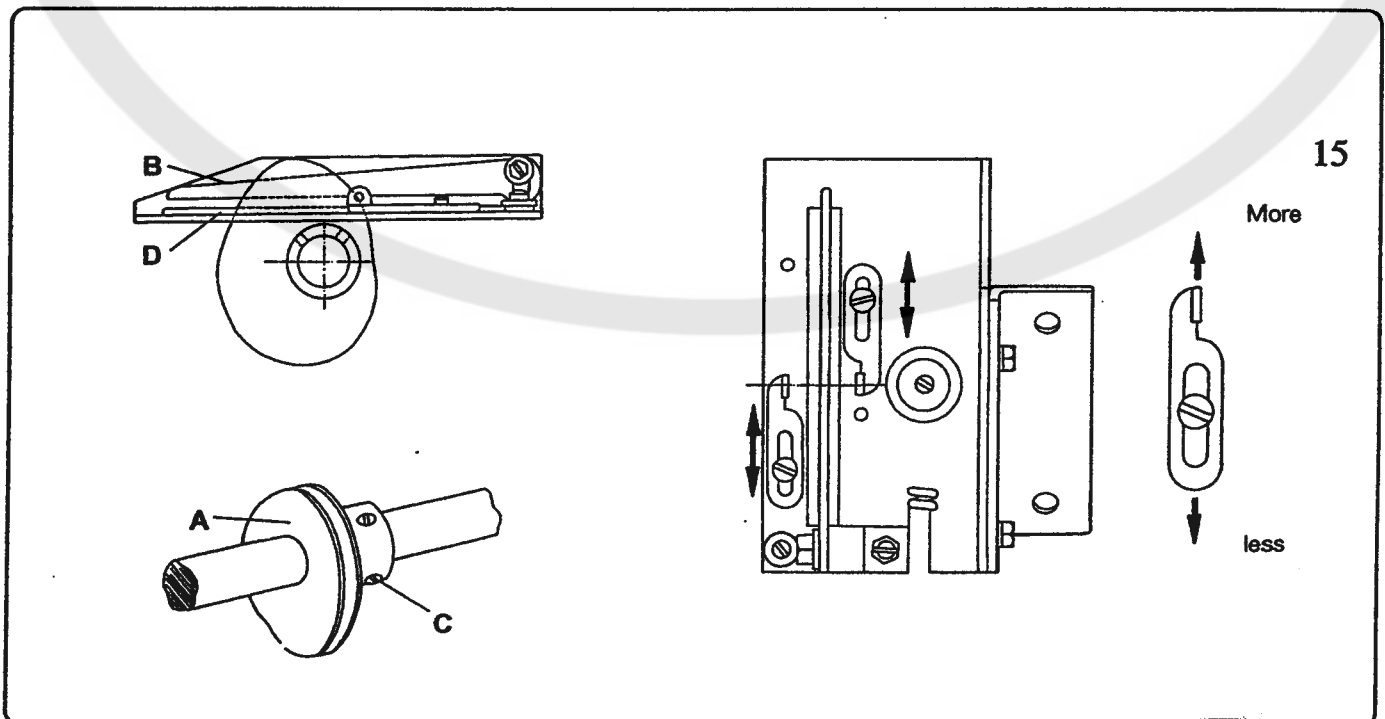

# 10. SETTING TOP SPREADER

(distance 21 fig. 17) By reducing distance "a", shown in fig. 16, the top spreader stroke is increased; by increasing distance "a" it is reduced. To modify distance "a", slacken screw(A) and shift big end of connecting rod(B). (fig. 16) (a = 7 for this machine)

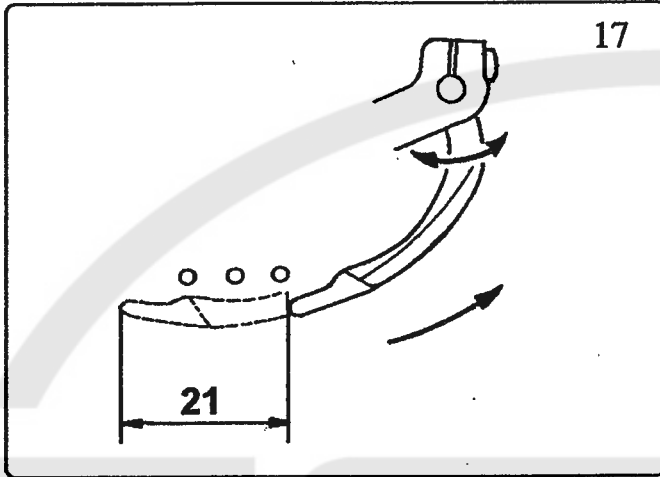

(distance 8.3) To obtain distance 8.3, slacken screw A (fig. 20) to obtain distance 0.5 between top spreader and needle plate.

(distance 5.5 fig. 18) To obtain distance 5.5, slacken screw (B) (fig. 20) and turn top spreader holder.

(distance 0.5) To obtain distance 0.5, slacken screw (A) (fig. 19) and turn the spreader.

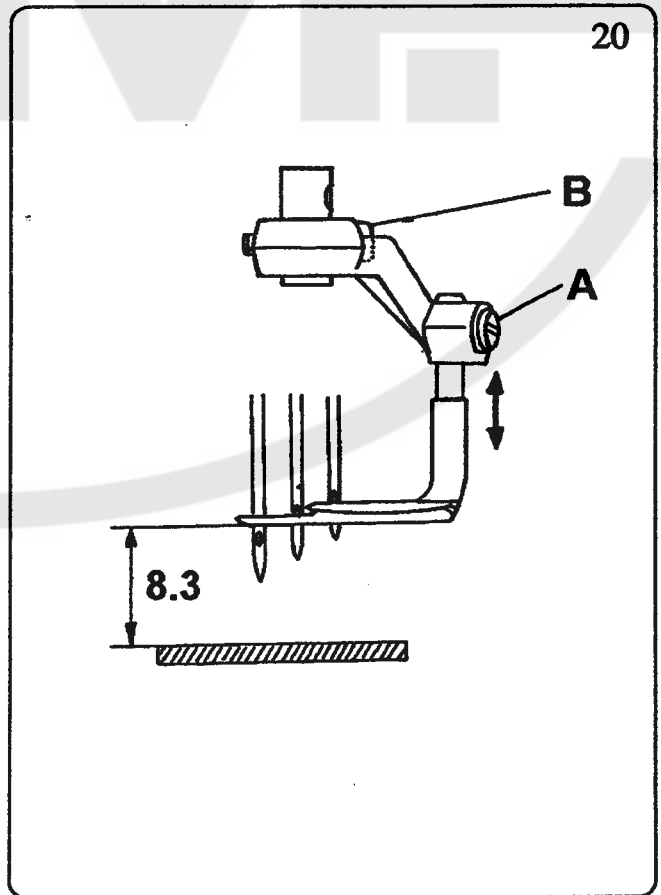
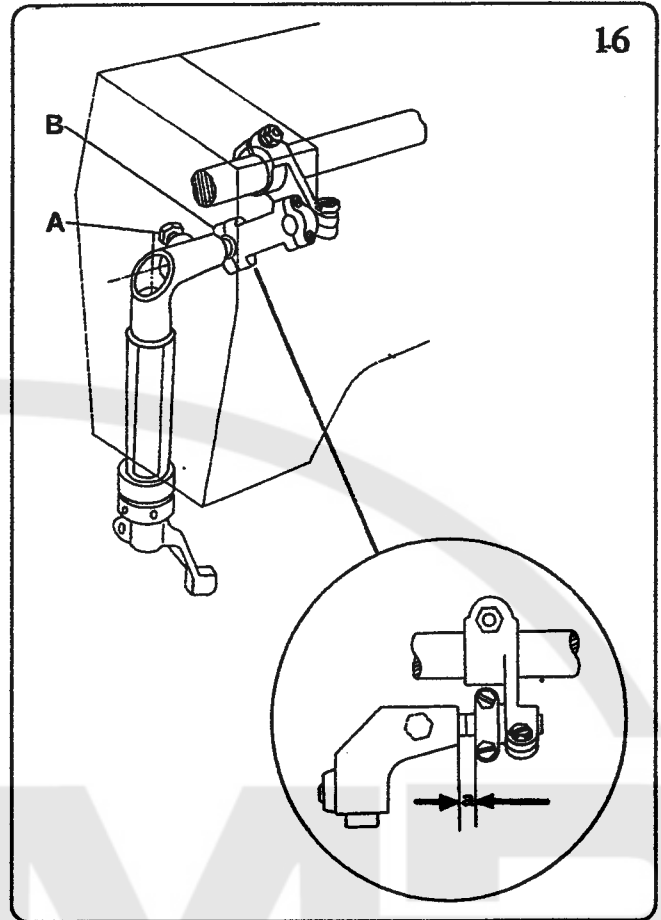
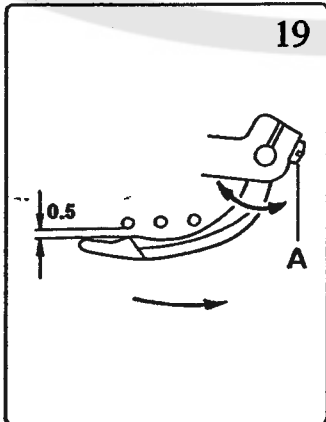
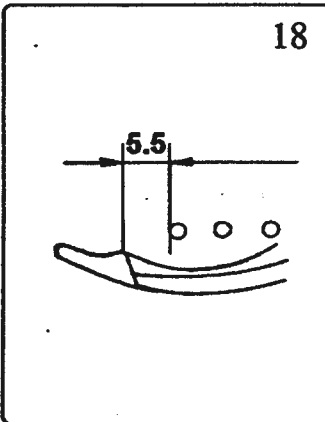

## 11. ADJUSTMENT OF THREAD GUIDE PLATE

Loosen screw (C) and move thread guide plate (B) up or down to make sure that when top spreader begins moving rightward, thread take-up plate(A) begins moving downward to touch thread just right and tensions it. when the required position is obtained, tighten screw(C)(fig. 21).

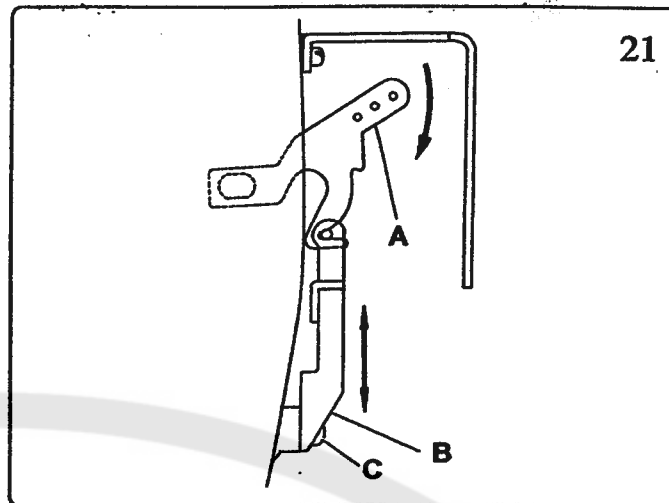

## 12. ADJUSTMENT OF FRONT AND REAR NEEDLE GUARD

The needle guard mechanism is not affected by adjusting of stitch length and it needs to be adjusted again after replacing the needle of different diameter. Loosen screw (E) and (D) (fig. 22) and remove the front needle guard. Turn eccentric shaft (C) until the mark is at the highest, when looper and right needle are positioned as shown in fig. 22, loose screw (A) and(B) to adjust the rear needle guard for distance 0-1mm between edge of rear needle guard and needle eye, then tighten screw(A) and(B).

The correct positioning of rear needle guard should be as follows: when looper tip swings to the right needle, Moving rear needle guard to close extremely to right needle keep a clearance 0mm between the rear needle guard and right needle them by adjusting the eccentric shaft(C). After finishing, tighten screw (D).

Adjustment of front needle guard: When looper tip swings to the right needle, to loosen screw(E), let the front needle guard keep a clearance of 0.05 - 0.1 mm with right needle, then tighten screw (E). (fig. 22)

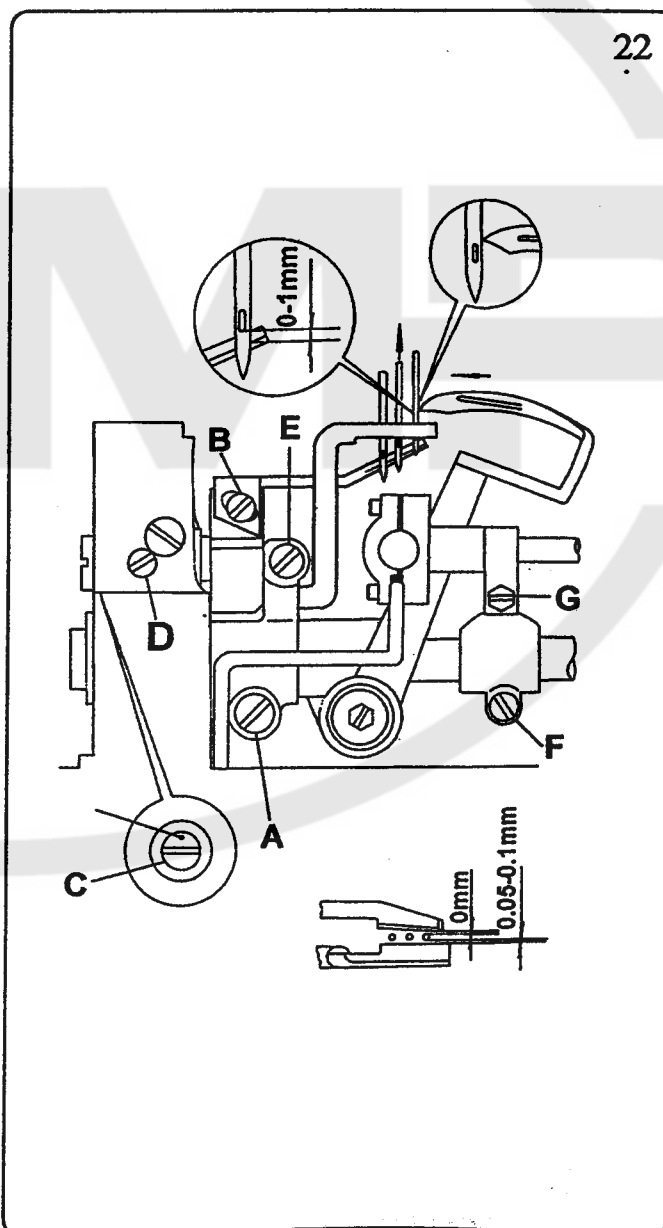



## 13. THREADING

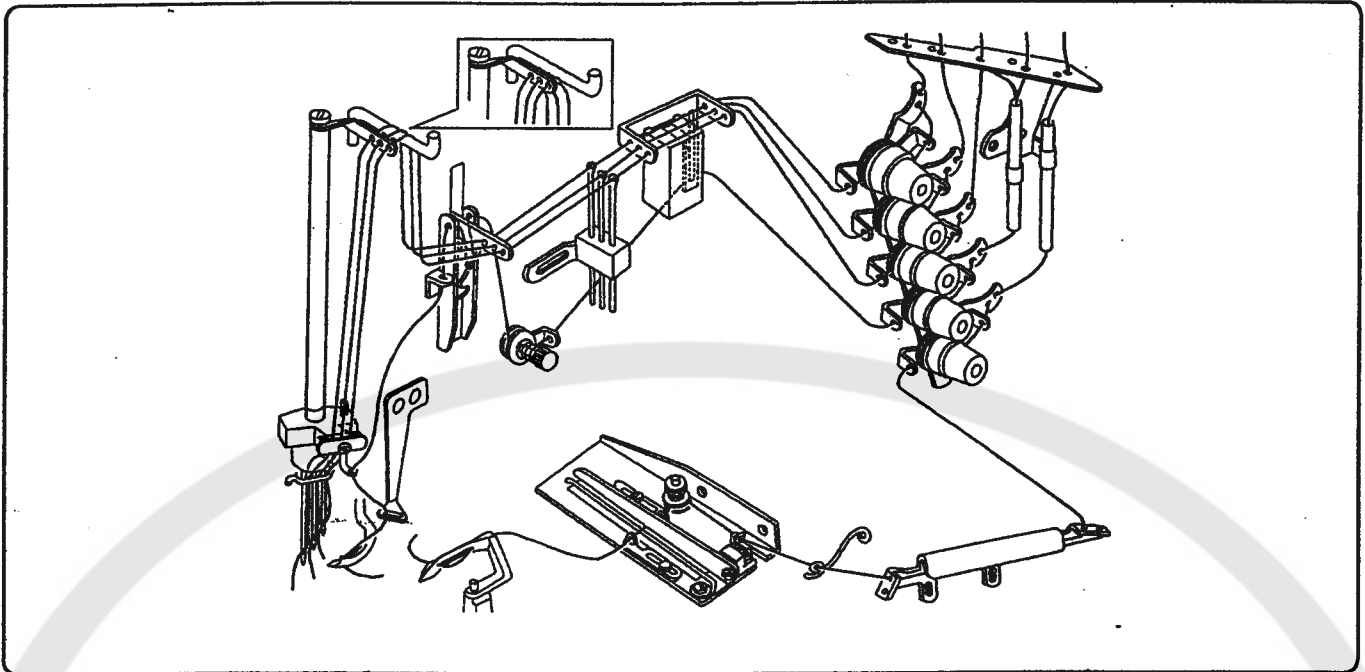

## 14. TROUBLES DUE TO INCORRECT ADJUSTMENT OF THE MACHINE

FAULT	PROBABLE CAUSE
Uneven stitches	1). Tensions badly adjusted    2). Thread take – up badly adjusted. 3). Incorrect threading        4). Irregular threads
2) Feed and fabric slipping sideways	1). Insufficient presser foot pressure    2). Feed dogs badly adjusted    3). Differential badly adjusted
3) Skipped stitches	1). Loper badly adjusted in relation to needle    2). Front and rear needle guard too far from needle 3). Needle badly positioned                            4). Loper thread take – up cam badly adjusted
4) Thread breaking	1). Tension too taut    2). Thread wound irregularly    3). Rear needle guard badly adjusted
5) Needle breaking	1). Needle bent    2). Needle badly mounted    3). Top spreader badly adjusted    4). Motor reversed
6) Holes made in fabric	1). Blunt needle    2). Needle size unsuitable
7) Oil leaking	1). Screws between base and oil reservoir insufficiently tightened 2). Oil drain plug screwed down too tightly 3). Oil reservoir gasket badly mounted
8) Lack of lubrication	1). Oil level too low    2). Oil tubes clogged    3). Oil screen clogged

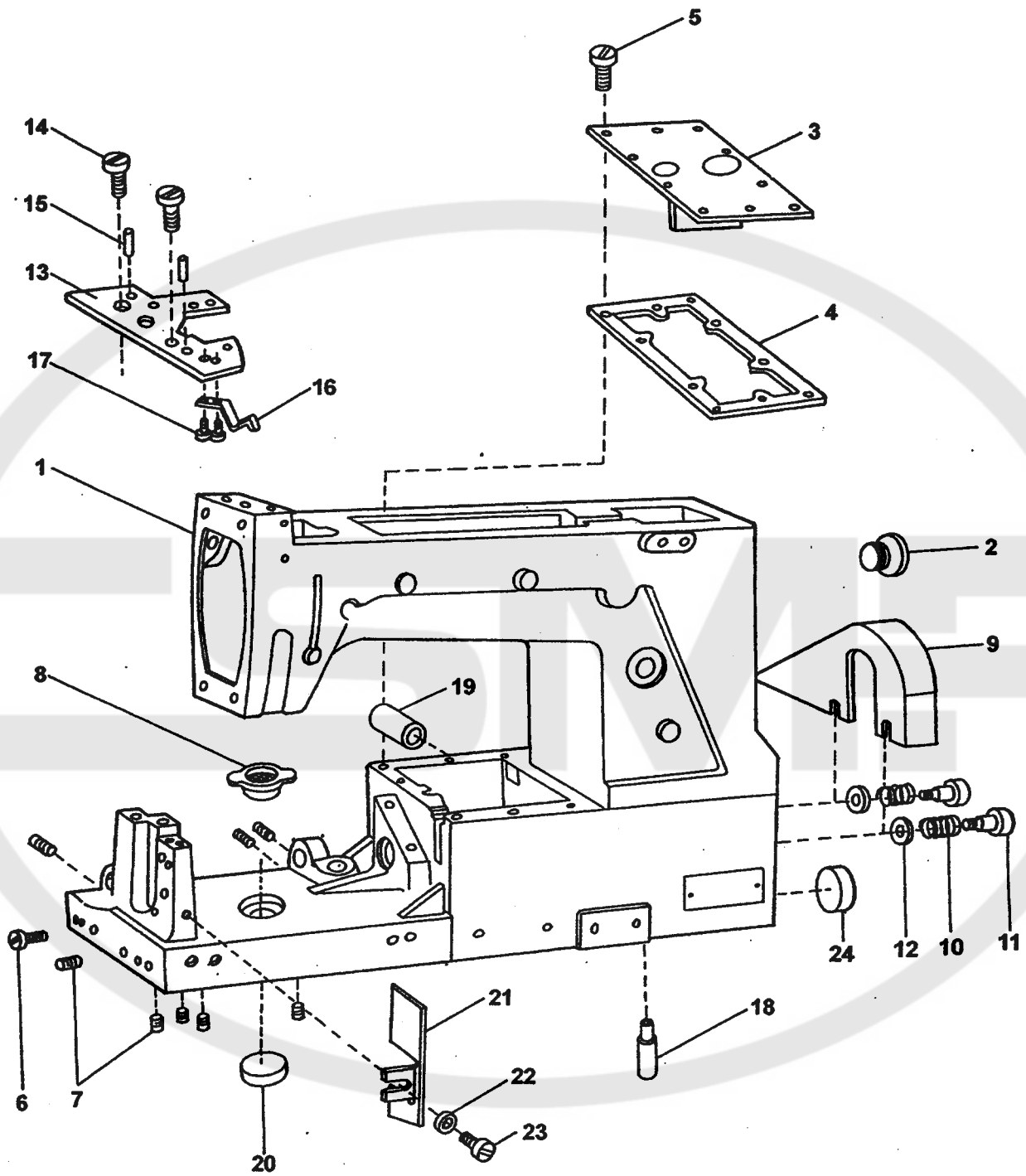

## 1. Arm & Bed Parts (1)

No.	Ref. No.	Description	QT.
1	116T1 -001A	Arm	1
2	116T2 -012	Rubber	1
3	65T1 -005	Bed Cover assy.	1
4	8A1 -015B2	Gasket	1
5	GB68002	Screw M4 x8	8
6	BS40013	Oil adjusting screw	1
7	BS40012	Screw	8
8	58T7 -001A2	Oil screen	1
9	8A1 -035	Belt guard	1
10	8A1 -036	Spring	2
11	BS20014	Screw	2
12	8A1 -037	Washer	2
13	8A1 -016	Throat plate support	1
14	BS10023	Screw	2
15	8A1 -018	Pin	2
16	8A1 -019	Latch spring	1
17	GB66012	Screw	2
18	116T1 -005	Oil return pipe	1
19	116T3 -005	Bushing	1
20	22T1 -016	Rubber $\Phi$ 27	1
21	116T5 -009	Looper holder oil stopping plate	1
22	BQ10008	Gasket	1
23	GB66013	Screw M4 x6	1
24	22T1 -003C3	Rubber $\Phi$ 19	1

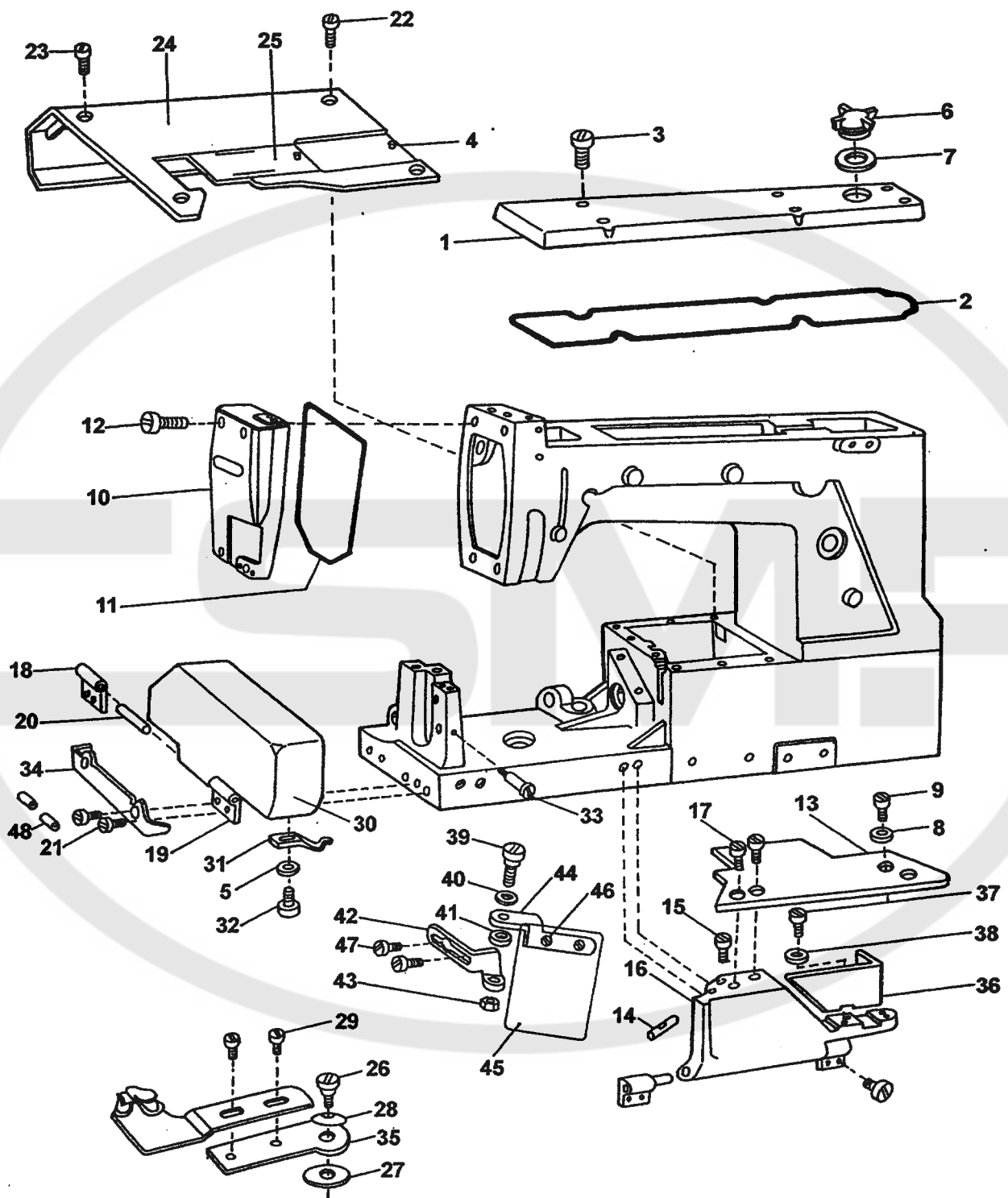

## 2. Arm & Bed Parts (2)

No.	Ref. No.	Description	QT.
1	65T1 -004	Top cover	1
2	8A1 -003	Gasket	1
3	GB66033	Screw M6 x20	6
4	BS40011	Positioning screw M3.5 x6	1
5	BQ10008	Washer	1
6	43T1 -002B2	Oil check window	1
7	43T1 -002B3	Seal ring	1
8	8A1 -039	Positioning ring	1
9	GB68002	Screw M4 x8	1
10	116T1 -003	Face plate	1
11	8A1 -010	Gasket for face plate	1
12	GB66026	Screw M5 x20	4
13	8A1 -022	Cloth plate for front cover	1
14	8A1 -020	Spring pin	1
15	GB66010	Screw M3 x6	1
16	8A1 -021	Front cover	1
17	GB69012	Screw M4 x10	2
18	8A1 -023	Left hinge	2
19	8A1 -024	Right hinge	2
20	8A1 -025	Hing pin	4
21	GB66022	Screw M5 x10	8
22	GB66018	Screw M4 x14	2
23	GB69006	Screw M4 x7	2
24	8A1 -026	Cloth plate	1
25	116T1 -009C	Slide plate assy.	1
26	8A1 -041	Screw	1
27	8A1 -042	Washer	1
28	JO.0.54	Washer	1
29	8A1 -043	Screw	2
30	8A1 -028	Left cover	1
31	8A1 -029	Latch spring	1
32	GB66012	Screw	1
33	BS20014	Set screw	1
34	8A1 -031	Fitting plate for hinge	1
35	8A1 -044	Edge guide base	1
36	8A1 -047	Dust cover	1
37	GB66012	Screw	1
38	BQ10008	Washer	1
39	116T1 -004B3	Screw	1
40	GB860 -87.4	Washer	1
41	BQ10001	Washer	1
42	116T1 -004B4	Protector plate base	1
43	GB52001	Protector plate holder nut M3	1
44	116T1 -004B2	Protector plate holder	1
45	116T1 -004B1	Protector plate	1
46	GB66007	Screw M3 x4	2
47	GB66012	Screw M4 x5	2
48	116T1 -006	Left cover gasket	2

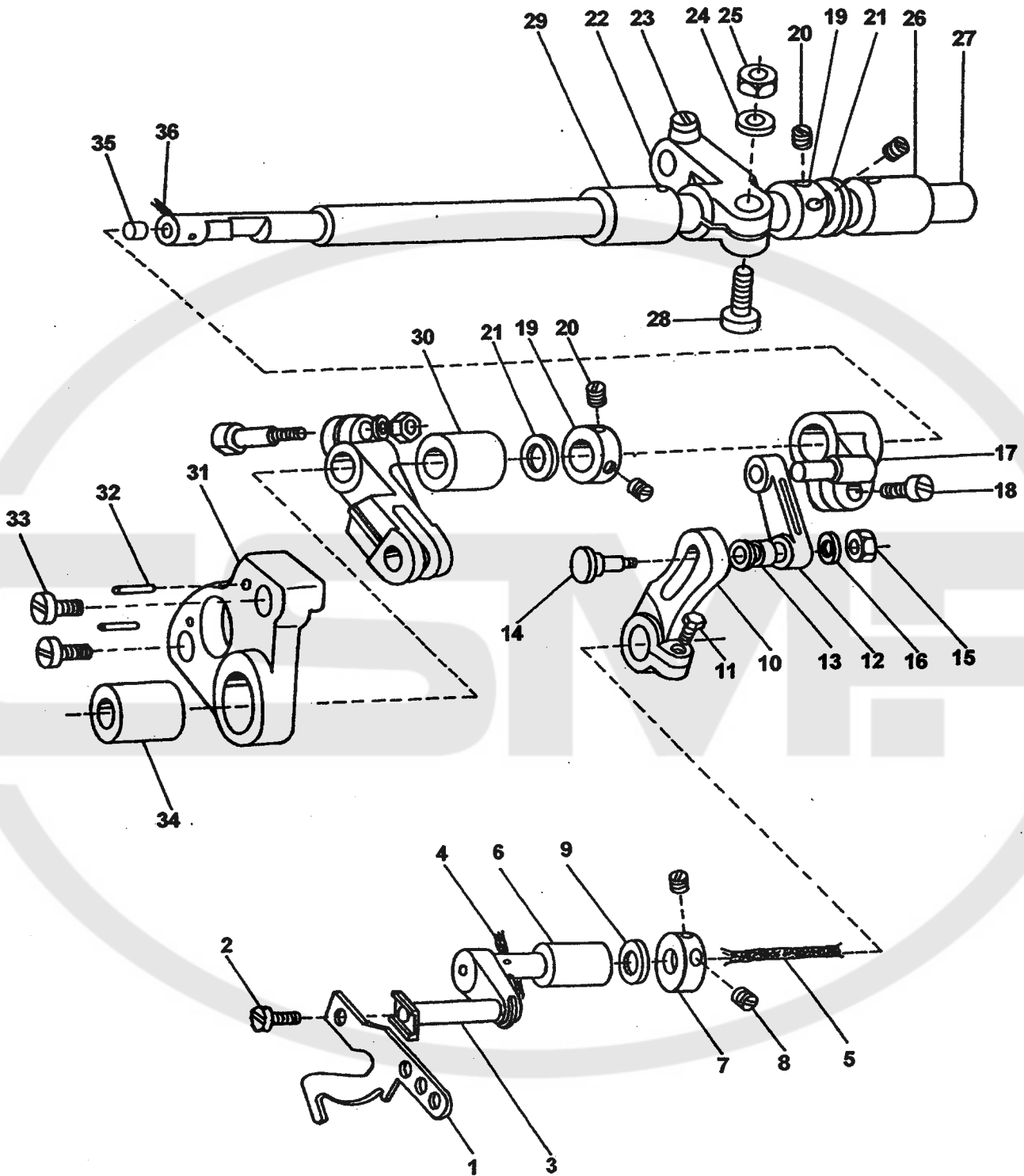

### 3. Needle Bar & Thread Tank –up Mechanism (1)

No.	Ref. No.	Description	QT.
1	116T2 -001	Thread take –up plate	1
2	43T2 -020	Set screw M4 x0.5 x6	1
3	43T2 -021	Thread take –up rock shaft	1
4	116T3 -012	Oil wick $\Phi 2 \times 20$	2
5	116T3 -012	Oil wick $\Phi 2 \times 85$	1
6	43T2 -022	Bushing	1
7	43T2 -023	Collar	1
8	GB74009	Set screw M4 x5	2
9	43T2 -024	Washer	1
10	43T2 -025F1	Adjusting crank	1
11	43T2 -025F2	Set screw M5 x10	1
12	43T2 -025F3	Link for adjusting crank	1
13	43T3 -010E9	Roller	1
14	43T3 -010E7	Screw	1
15	GB55001	Nut M4	1
16	43T3 -010E10	Washer	2
17	65T2 -009	Thread take –up crank	1
18	43T2 -025F5	Set screw M6 x0.75 x15	1
19	65T2 -008	Collar for arm shaft	2
20	GB74025	Set screw M6 x0.75 x4	4
21	BQ10052	Washer	2
22	8A2 -062	Arm shaft crank	1
23	BS30005	Screw M6 x8	1
24	BQ10026	Washer	1
25	GB52006	Nut M6	1
26	116T2 -010	Back bushing for arm shaft	1
27	116T2 -008C1	Arm shaft	1
28	8A2 -019	Set screw	1
29	65T2 -015	Middle back bushing for arm shaft	1
30	116T2 -009	Front bushing for arm shaft	1
31	116T2 -017F1	Holder base	1
32	43T2 -010	Pin	2
33	GB66023	Screw M5 x12	2
34	43T2 -009E2	Bushing	1
35	43T2 -008D2	Plug for arm shaft	1
36	116T3 -012	Oil wick for arm shaft $\Phi 1.5 \times 10$	1

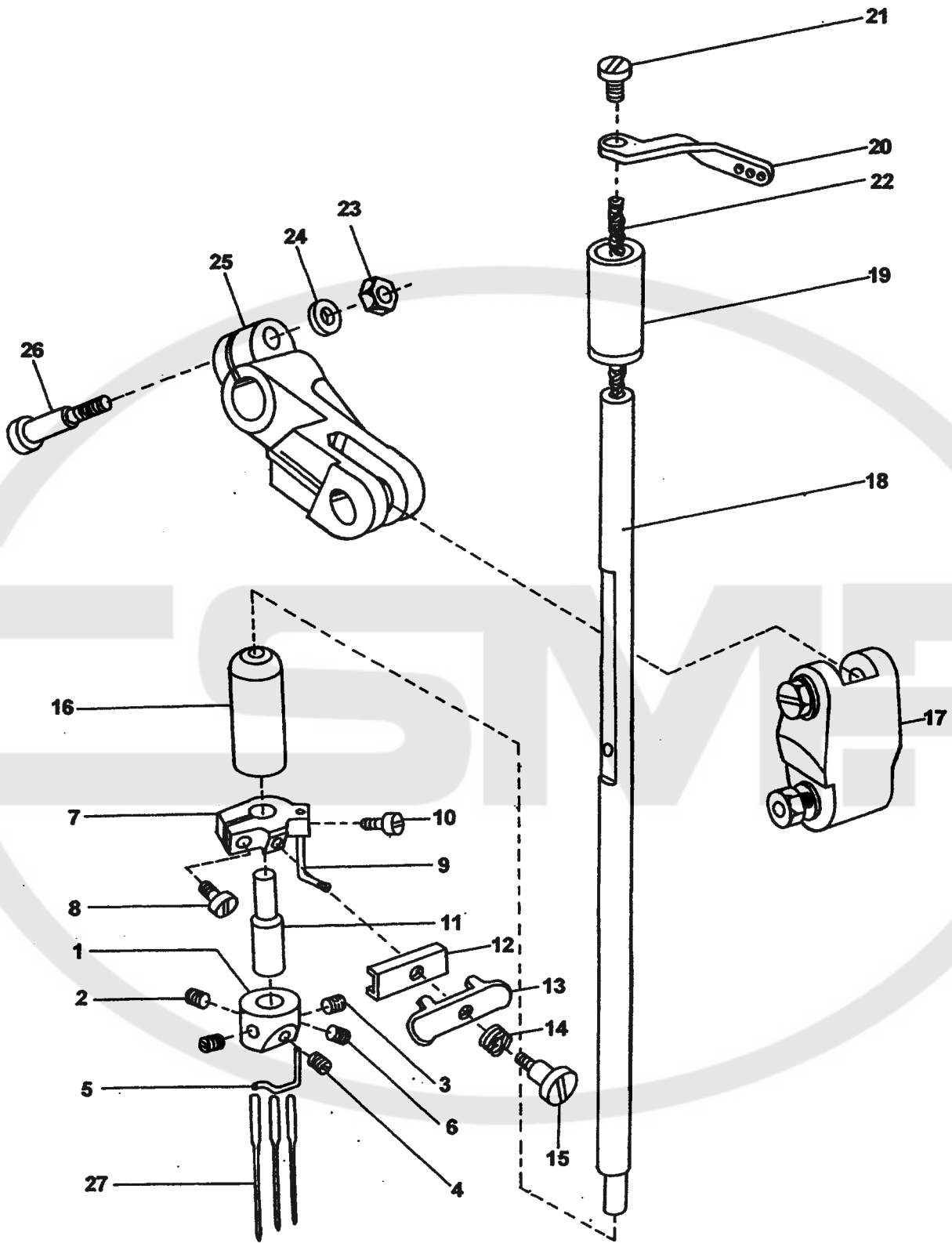



#### 4. Needle Bar & Thread Tank – up Mechanism (2)

No.	Ref. No.	Description	QT.
1	8A2 –001	Needle holder	1
2	8A2 –002	Set screw	1
3	GB74008	Set screw	2
4	GB74002	Set screw	1
5	8A2 –003	Thread guard	1
6	GB74001	Set screw	1
7	116T2 –013G2	Holder for covering thread guard	1
8	BS30007	Set screw	1
9	8A2 –006	Covering thread guard	1
10	GB66007	Set screw	1
11	8A2 –007	Needle bar adapter	1
12	116T2 –013G1	Pressing gasket plate	1
13	81T1 –005C2	Pressing plate	1
14	81T1 –005C3	Spring	1
15	81T1 –005C4	Screw	1
16	8A2 –014	Needle bar bushing (lower)	1
17	116T2 –011D	Needle bar fittings	1
	43T2 –003C2	Needle bar link	2
	43T2 –003C3	Roller for needle bar	1
	43T2 –003C4	Screw	1
	GB52002	Nut M4	1
	GB859 –76	Washer	2
	43T2 –003C5	Roller for link	2
	43T2 –020	Screw M4 x0.5 x6	2
	BQ10008	Washer	1
18	116T2 –011D1	Needle bar	1
19	8A2 –015	Needle bar bushing (upper)	1
20	116T2 –011D2	Thread take – up for needle bar	1
21	116T2 –011D3	Screw	1
22	116T3 –012	Oil wick $\Phi 4 \times 45$	1
23	43T2 –003C8	Nut	1
24	BQ10026	Washer	1
25	43T2 –003C6	Needle bar crank	1
26	43T2 –003C7	Screw	1
27	GK16 x90(14)	Needle	3

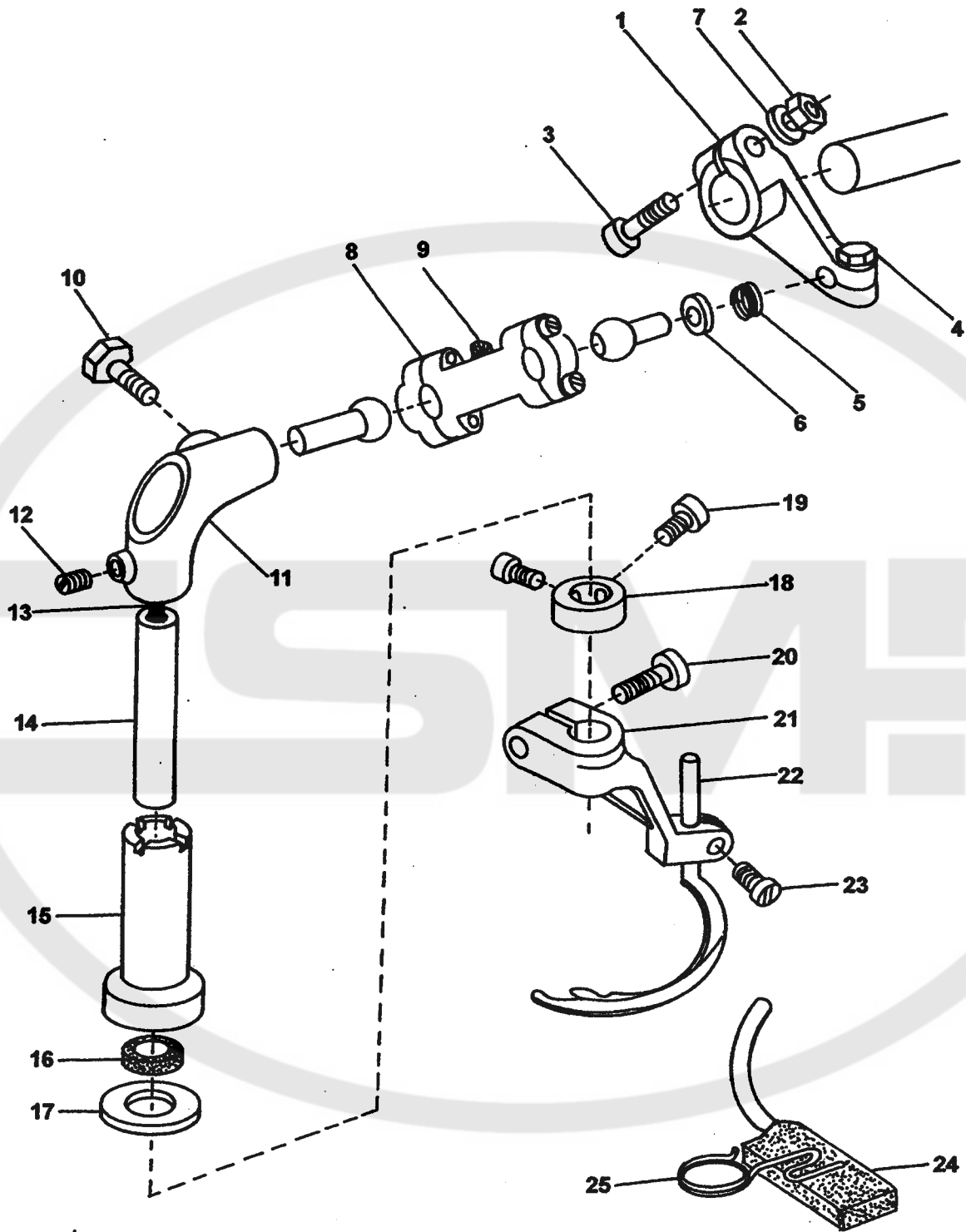

## 5. Needle Bar & Thread Tank –up Mechanism (3)

No.	Ref. No.	Description	QT.
1	116T2 -002	Crank	1
2	GB52006	Screw & Nut	1
3	8A2 -019	Set screw	1
4	BS30006	Set screw	1
5	43T3 -010E3	Spring	1
6	43T3 -010E2	Washer	1
7	BQ10026	Washer	1
8	43T3 -010E1	Top spreader link accessory	1
9	116T3 -012	Oil wick $\Phi 1.5 \times 30$	1
10	43T3 -009D2	Screw	1
11	43T3 -009D1	Upper crank	1
12	43T2 -014	Screw	1
13	116T3 -012	Oil wick $\Phi 1.5 \times 104$	1
14	43T3 -003	Crank shaft	1
15	43T3 -006B1	bushing	1
16	43T3 -006B2	Oil seal	1
17	43T3 -008	Washer (lower).	1
18	8A6 -003	Gasket	1
19	BS10002	Screw M3.5 x5	2
20	GB66018	Set screw M4 x14	1
21	43T3 -002	crank for top spreader	1
22	43T3 -001A1	Top spreader	1
23	BS30006	Set screw M3.5 x8	1
24	22T8 -015	Filter felt	1
25	36T10 -002	Filter felt clamp	1

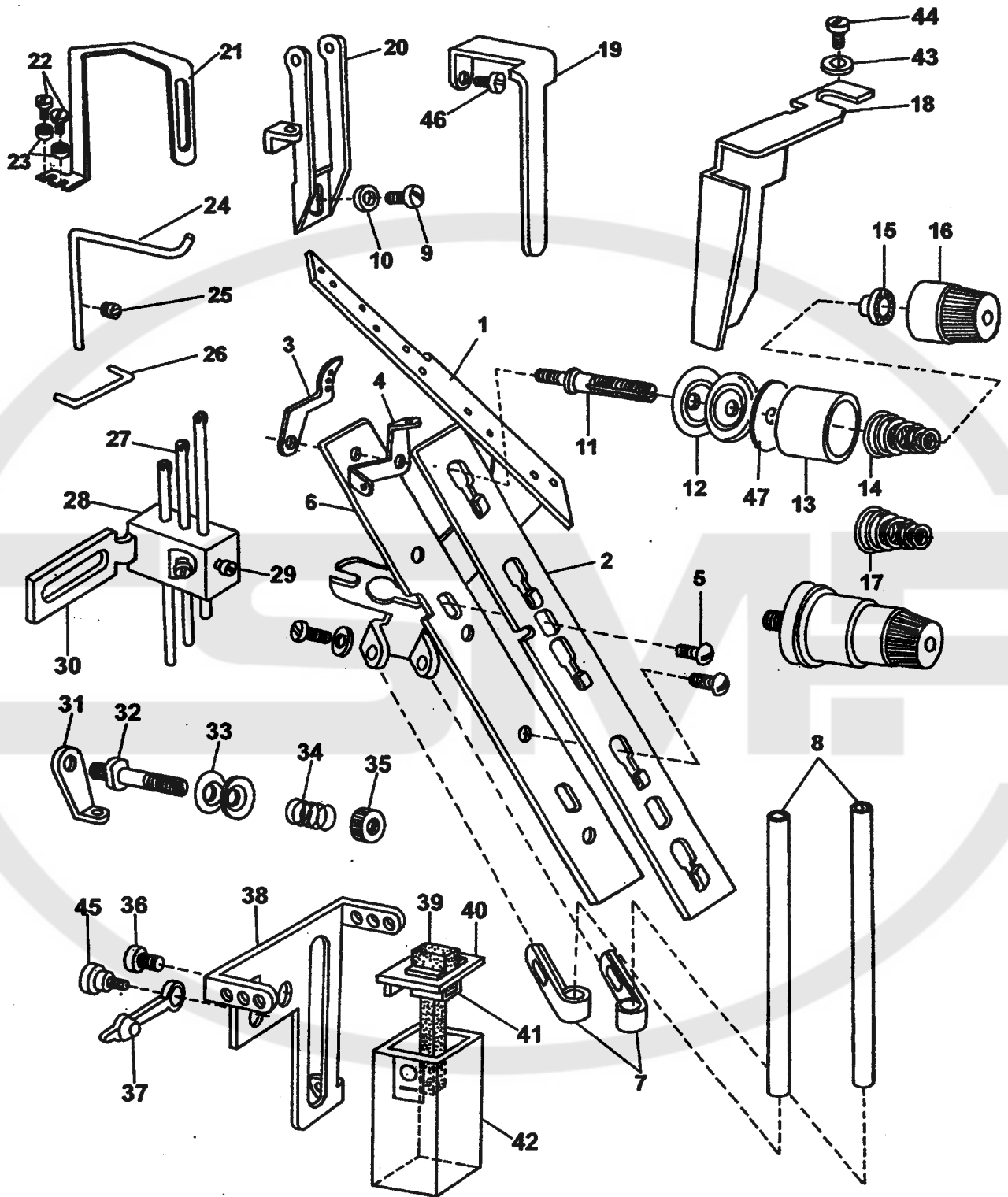

## 6. Needle Bar & Thread Tank – up Mechanism (4)

No.	Ref. No.	Description	QT.
1	116T2 -014E1	Main thread guard holder	1
2	116T2 -021	Thread release plate	1
3	116T2 -015	Upper thread tension guide plate	5
4	116T2 -016	Thread tension guide plate	5
5	GB66022	Thread guide base screw	2
6	116T2 -020	Thread guide base	1
7	116T2 -014E2	Thread guide clamp	2
8	116T2 -014E3	Main thread guide	2
9	GB66015	Screw M4 x8	5
10	BQ10008	Washer	5
11	116T2 -024	Tension stud	5
12	22T1 -012F5	Tension disc	10
13	28T2 -060H2	Tension dust cover	5
14	28T2 -060H3	Tension spring	3
15	28T2 -060H4	Stop disc	5
16	28T2 -060H5	Tension nut	5
17	28T2 -060H3 -1	Tension spring	2
18	116T2 -019	Oil guard for thread take -up	1
19	116T2 -005	Thread take -up guard	1
20	116T2 -007	Covering thread guide plate	1
21	116T2 -025	thread take -up cover	1
22	GB66015	ScrewM4 x8	2
23	BQ10008	Washer	2
24	116T2 -023	Tension hook	1
25	BS10046	Screw M4 x7	1
26	43T2 -027	Thread guard for needle bar	1
27	116T2 -004B1	Thread guide bar	3
28	116T2 -004B2	Thread guide bar base	1
29	GB66007	Screw M3 x4	4
30	116T2 -004B3	Thread guide bar base support	1
31	116T2 -006	Covering thread guide plate	1
32	116T2 -018	Screw	1
33	8A2 -068	Tension disc	2
34	8A2 -067	Tension spring	1
35	8A2 -088	Tension nut	1
36	61 -04 -01/B2	Oil tank screw	1
37	48T9 -001A3	Rubber	1
38	116T2 -003A1	Bracket for silicone oil cup	1
39	116T2 -003A4	Silicone oil felt	1
40	116T2 -003A2	Silicone oil cup cover	1
41	116T2 -003A3	Silicone oil felt clamp	1
42	48T9 -001A1	Silicone oil cup	1
43	BQ10008	Washer	1
44	GB66012	Screw M4 x5	1
45	48T9 -001A2	Screw	1
46	GB66013	Screw M4 x6	1
47	28T2 -060H7	Oil felt	5

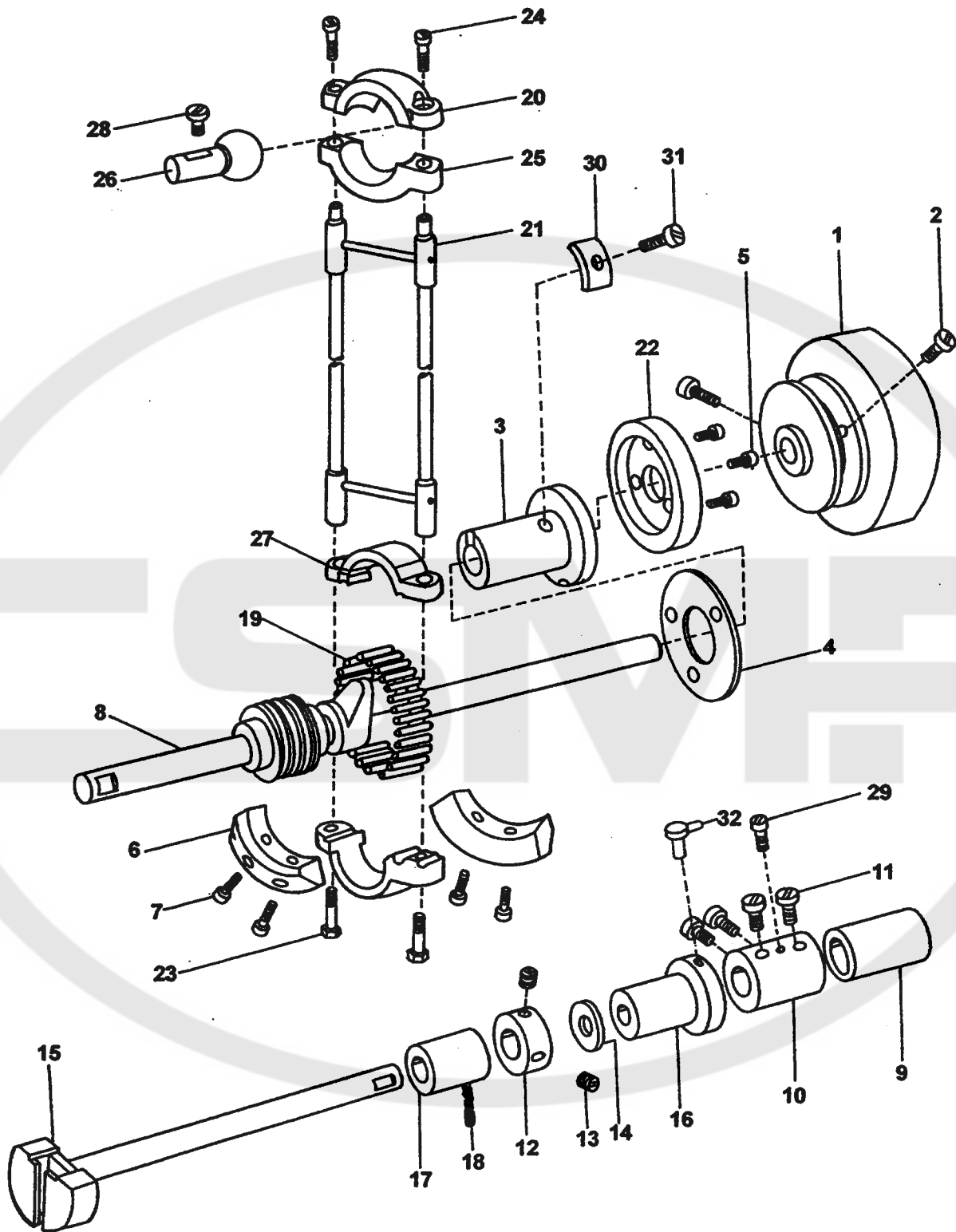

## 7. Feed & Feed Lifting Mechanism (1)

No.	Ref. No.	Description	QT.
1	8A4 -001	Machine pulley	1
2	65T4 -005	Set screw M6 x13	2
3	116T4 -003	Back bushing socket	1
4	8A4 -003	Oil seal	1
5	GB66023	Screw M5 x12	3
6	8A4 -005	Balance weight	2
7	GB66024	Set screw M5 x14	4
8	116T4 -002B	Back shaft segment assy.	1
9	116T4 -004	Front bushing for back shaft segment	1
10	8A4 -009	Coupling	1
11	65T4 -004	Screw M6 x0.75 x8	4
12	8A4 -010	Collar	1
13	GB74025	Set screw M6 x0.75 x4	2
14	BQ10050	Washer	3
15	8A4 -011	Front shaft segment	1
16	116T4 -006	Back bushing for front shaft segment	1
17	116T4 -005	Front bushing for front shaft segment	1
18	116T3 -012	Oil wick $\Phi 7 \times 40$	1
19	8A4 -006	Needle roller	30
20	8A4 -007A3	Upper cover of connecting rod	1
21	8A4 -007A6	Connecting rod assy.	2
	8A4 -007A7	Pin	2
22	116T4 -010	Back shaft top cover	1
23	8A4 -007A2	Screw	2
24	GB66019	Screw M4 x22	2
25	8A4 -007A4	Lower cover of connecting rod	1
26	8A2 -063	Ball stud	1
27	8A4 -007A1	Bearing bracket	1
28	BS30005	Screw M6 x8	1
29	GB66007	Screw M3 x4	1
30	116T4 -009	Back bushing socket washer.	1
31	GB66012	Screw M4 x5	1
32	43T7 -034	Back shaft segment oil nozzle	1

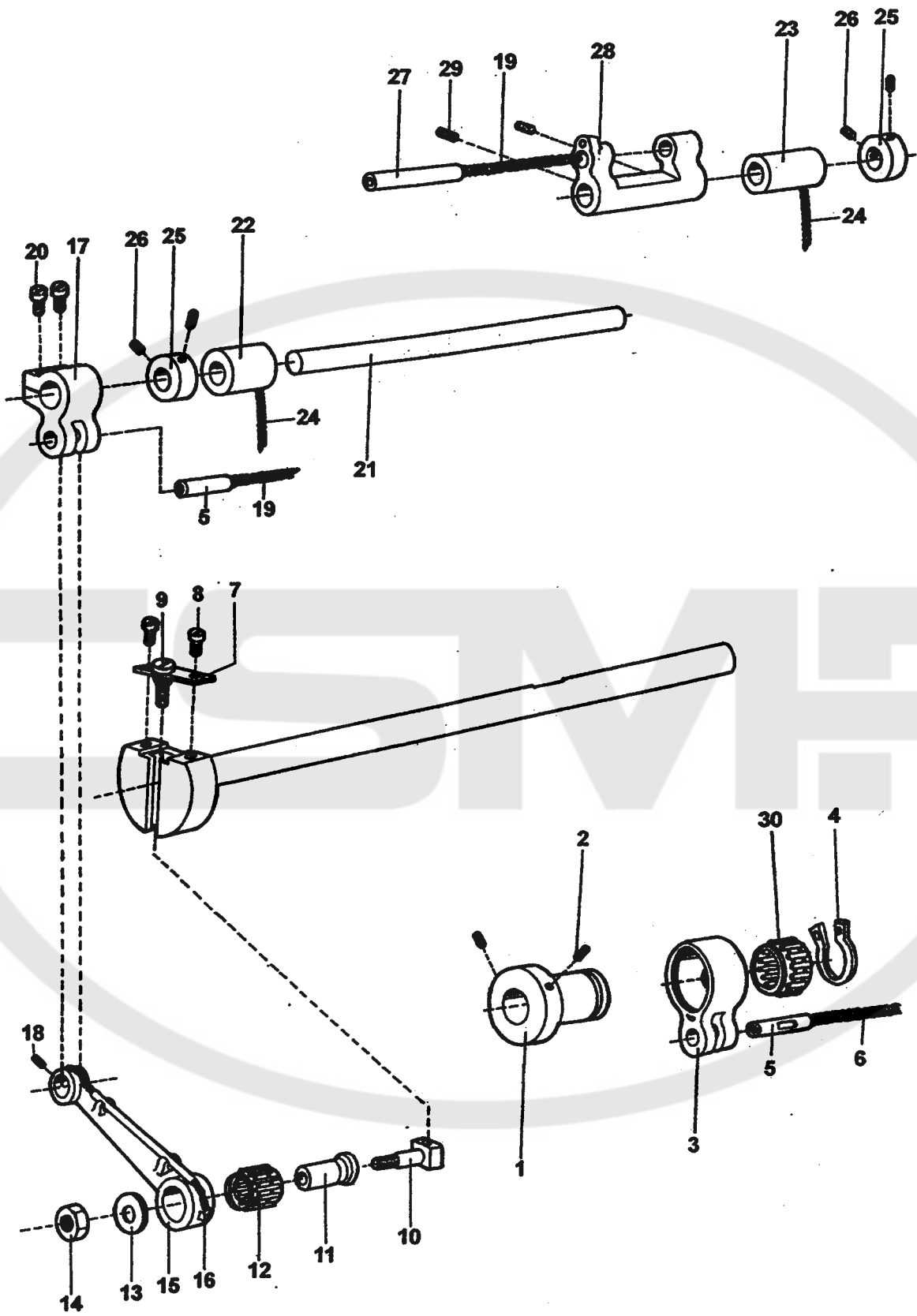



## 8. Feed & Feed Lifting Mechanism (2)

No.	Ref. No.	Description	QT.
1	116T4 -001A1	Feed lifting cam	1
2	GB74019	Set screw M5 x0.5 x6	2
3	116T4 -001A2	Feed lifting link	1
4	GB894.1 -86 -18	Stop sleeve	1
5	8A4 -017	Pin	1
	8A4 -017	Pin	1
6	116T3 -012	Oil wick $\Phi 4 \times 60$	1
7	8A4 -019	Positioning plate	1
8	GB66010	Screw M3 x6	2
9	8A4 -020	Adjusting screw	1
10	8A4 -021	Feed regulating slide block	1
11	8A4 -022	Slide block bushing	1
12	8A4 -023C	Needle bearing assy.	1
13	BQ10028	Washer	1
14	GB52007	Nut M6 left	1
15	8A4 -025D	Feed connecting rod assy.	1
	8A4 -025D1	Feed connecting rod	1
	8A4 -025D2	Oil pipe	1
16	116T3 -012	Oil wick $\Phi 3 \times 155$	1
17	8A4 -026	Feed crank	1
18	GB74007	Set screw M4 x3.5	1
19	116T3 -012	Oil wick $\Phi 4 \times 60$	1
	116T3 -012	Oil wick $\Phi 2.5 \times 150$	1
20	8A4 -058	Screw	2
21	8A4 -027	Feed rock shaft	1
22	8A4 -028	Front bushing for feed rock shaft	1
23	8A4 -028	Back bushing for feed rock shaft	1
24	116T3 -012	Oil wick $\Phi 7 \times 30$	2
25	8A4 -029	Collar	2
26	GB74019	Set screw M5 x0.5 x6	4
27	8A4 -032	Feed bar shaft	1
28	8A4 -030	Feed bar crank	1
29	65T4 -006	Set screw M6 x9.5	2
30	8A4 -016B	Needle bearing assy.	1

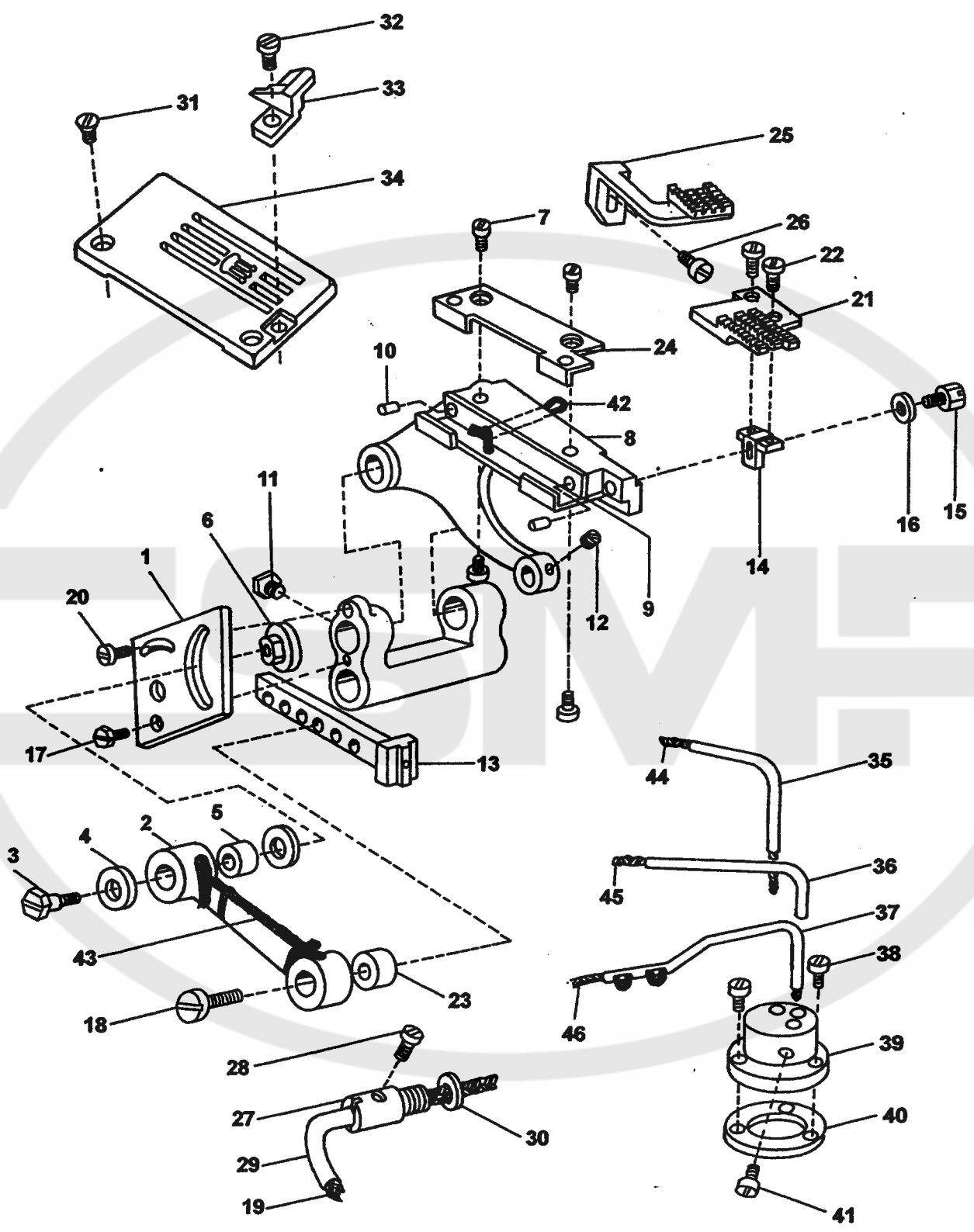

## 9. Feed & Feed Lifting Mechanism (3)

No.	Ref. No.	Description	QT.
1	8A4 - 031	Regulating plate	1
2	8A4 - 033	Differential feed bar driving connection	1
3	GB29012	Adjusting screw M5 x18	1
4	BQ10019	Washer	2
5	8A4 - 034	Roller	1
6	BL10007	Nut M5	1
7	BS10020	Screw	4
8	8A4 - 041	Feed bar	1
9	8A4 - 042	Shim plate	1
10	8A4 - 043	Pin	2
11	GB74018	Set screw M5 x6	1
12	GB66010	Set screw M3 x6	1
13	8A4 - 036	Slide block for differential feed dog.	1
14	8A4 - 045	Feed bar carrier	1
15	8A4 - 046	Screw	1
16	BQ10017	Washer	1
17	8A4 - 056	Screw	1
18	8A4 - 057	Screw	1
19	116T3 - 012	Oil wick $\Phi 2.5 \times 300$	1
20	GB66022	Adjusting screw M5 x10	1
21	8A4 - 044	Feed dog	1
22	GB66010	Screw M3 x6	2
23	8A4 - 037	Roller of slide block	1
24	8A4 - 038	Guide plate of slide block	2
25	8A4 - 040	Differential feed dog	1
26	GB66015	Screw M4 x8	1
27	8A4 - 047	Oil pipe bushing	1
28	GB66007	Set screw M3 x4	1
29	8A4 - 048	Oil pipe	1
30	8A4 - 049	Washer	1
31	116T4 - 008	Screw M4 x6	2
32	116T4 - 007C3	Guide plate screw	1
33	116T4 - 007C2	Lower guide plate	1
34	116T4 - 007C1	Needle plate	1
35	8A4 - 052	Oil pipe	1
36	8A4 - 053	Oil pipe	1
37	8A4 - 054	Oil pipe	1
38	GB66016	Screw M4 x10	3
39	8A4 - 050	Oil pipe bracket	1
40	8A4 - 051	Washer	1
41	GB66008	Set screw M3 x5	3
42	116T3 - 012	Oil wick $\Phi 3 \times 40$	1
43	116T3 - 012	Oil wick $\Phi 3 \times 120$	1
44	116T3 - 012	Oil wick $\Phi 2.5 \times 135$	1
45	116T3 - 012	Oil wick $\Phi 2.5 \times 160$	1
46	116T3 - 012	Oil wick $\Phi 2.5 \times 200$	1

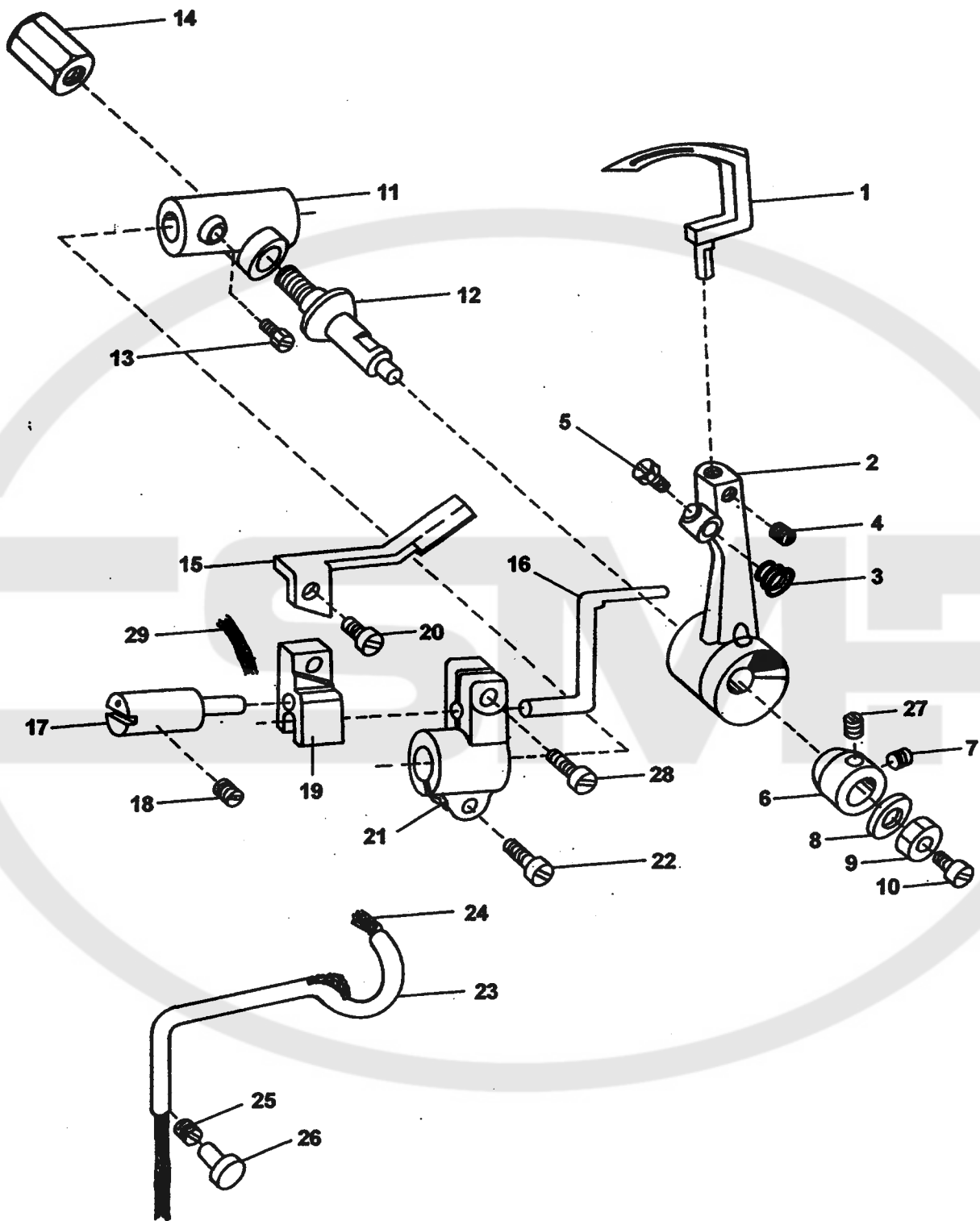

## 10. Looper Mechanism (1)

No.	Ref. No.	Description	QT.
1	8A5 -044	Looper	1
2	8A5 -003	Looper holder	1
3	8A5 -043	Stop spring	1
4	BS10046	Screw M4 x7	1
5	GB29009	Screw M5 x0.5 x8	1
6	8A5 -006	Collar	1
7	GB74015	Screw M5 x0.5 x4	1
8	BQ10024	Security washer	1
9	GB52006	Nut M6	1
10	BS10026	Security screw M3.5 x6	1
11	116T5 -001	Looper holder crank	1
12	8A5 -005	Looper holder shaft	1
13	8A5 -008	Adjusting screw	1
14	8A5 -045	Nut	1
15	116T5 -006	Back protecting plate	1
16	116T5 -004	Front protecting plate	1
17	116T5 -005	Protecting adjusting rod	1
18	GB74 -85	Set screw M5 x16	1
19	116T5 -007	Back protecting plate bracket	1
20	43T3 -022	Screw M3 x6.5	1
21	116T5 -003	Protecting crank	1
22	GB66023	Screw M5 x12	1
23	116T5 -002	Oil pipe	1
24	116T3 -012	Oil wick $\Phi 3 \times 100$	1
25	GB74 -85	Screw M4 x12	1
26	8A5 -042	Seal plug	1
27	GB74017	Screw M5 x0.5 x5	1
28	GB66015	Screw M4 x8	1
29	116T3 -012	Oil wick $\Phi 4 \times 25$	1

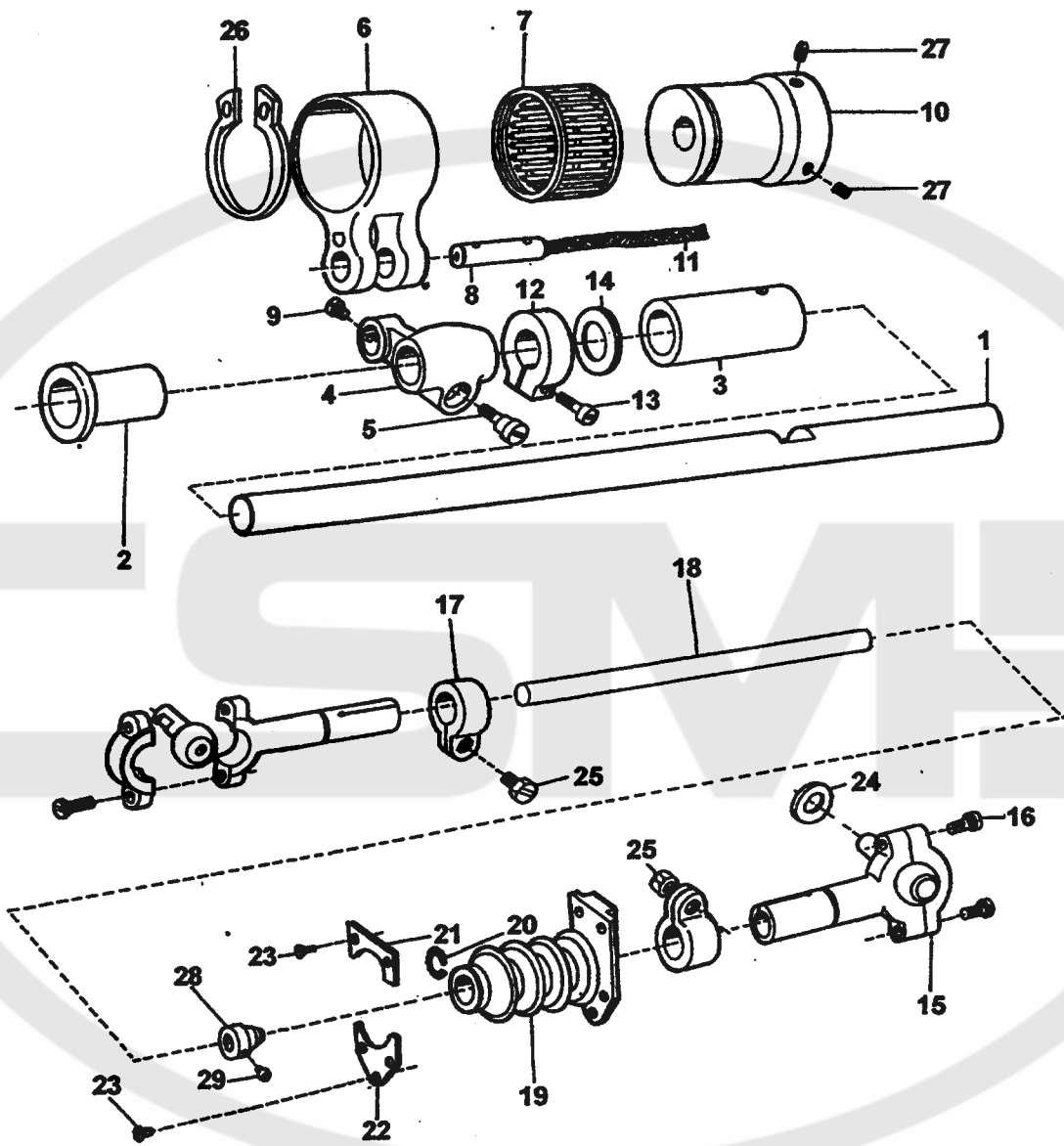

## 11. Looper Mechanism (2)

No.	Ref. No.	Description	QT.
1	8A5 - 009	Looper holder crank shaft	1
2	8A5 - 010	Front bushing	1
3	8A5 - 011	Back bushing	1
4	8A5 - 012	Crank shaft crank	1
5	BS30009	Set screw M5 x 12	1
6	116T4 - 001A2	Link for crank shaft crank	1
7	8A4 - 016B	Needle bearing assy.	1
8	8A4 - 017	Pin	1
9	GB66008	Screw M3 x 5	1
10	116T4 - 001A1	Link cam	1
11	116T3 - 012	Oil wick $\Phi 4 \times 60$	1
12	8A5 - 014	Collar	1
13	BS30011	Set screw M5 x 12	1
14	BQ10048	Washer	1
15	43T5 - 006C1	Connecting rod assy.	2
	43T5 - 006C2	Ball stud	2
	43T5 - 006C1a	Looper holder stud connecting rod	2
	43T5 - 006C1b	Cap for connecting rod	2
16	43T5 - 006C3c	Screw M3.5 x 10	4
17	43T5 - 007	Adjusting collar	2
18	43T5 - 009	Adjusting rod	1
19	8A5 - 020	Oil guard sleeve	1
20	8A5 - 021	Lock spring	1
21	8A5 - 022	Upper stop plate	1
22	8A5 - 023	Lower stop plate	1
23	BS10017	Screw	5
24	8A5 - 026	Washer	1
25	43T5 - 008	Adjusting screw M4 x 0.5 x 10	2
26	GB894.1 - 86 - 18	Stop sleeve	1
27	GB74019	Screw M5 x 0.5 x 6	2
28	65T5 - 001	Inner sleeve	1
29	GB66001	Set screw M2.5 x 3	1

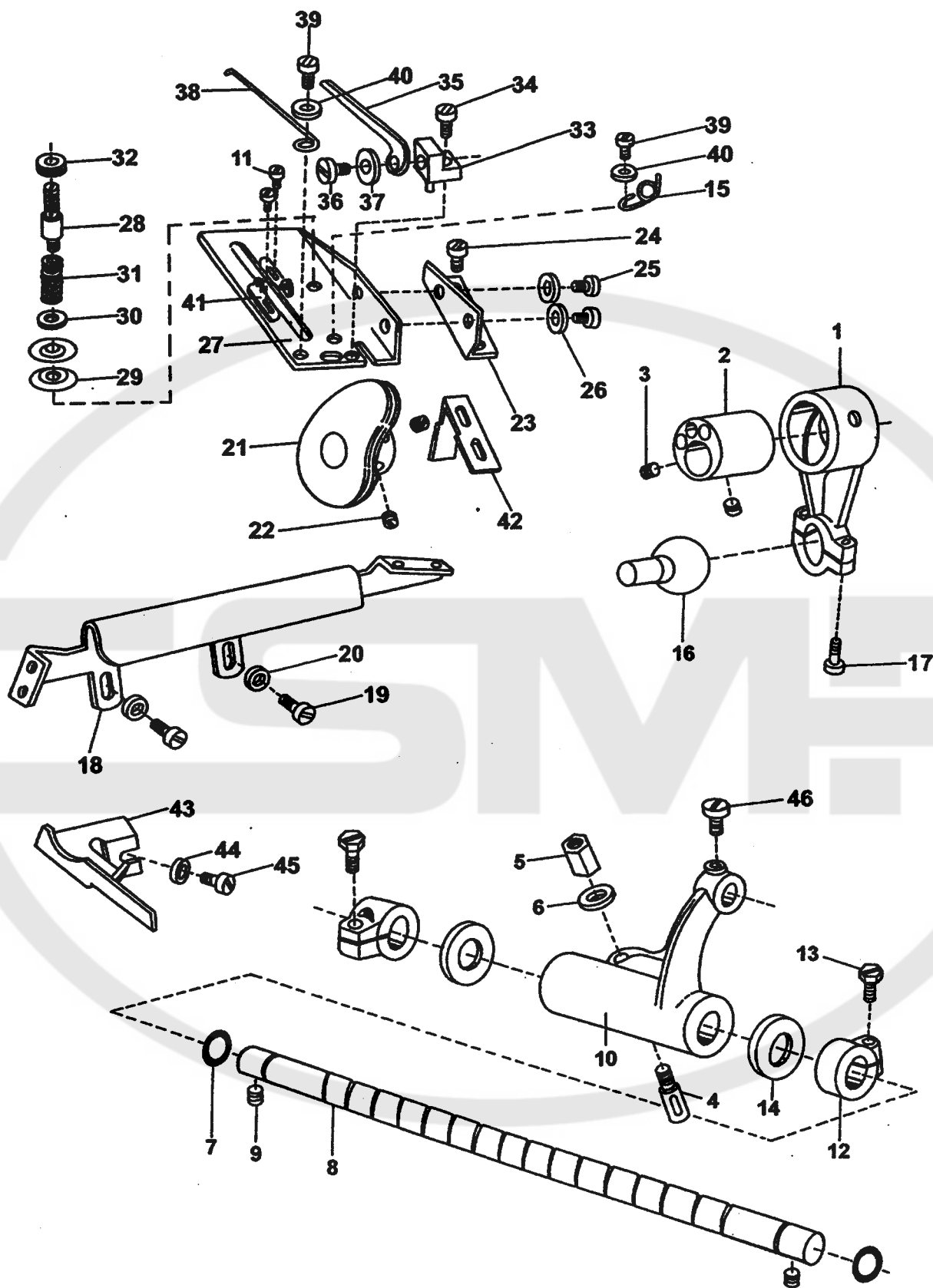



## 12. Lopper Mechanism (3)

No.	Ref. No.	Description	QT.
1	43T5 - 001A1a	Connecting rod assy.	1
2	43T5 - 001A5	Eccentric cam	1
3	GB74029	Set screw M6 x0.75 x6	2
4	8A5 - 046	Clamp screw	1
5	8A5 - 030	Clamp nut	1
6	BQ10018	Washer	1
7	8A5 - 029	Oil seal	2
8	8A5 - 040	Looper rock shaft	1
9	GB74035	Set screw M6 x16	2
10	8A5 - 027	Crank for lopper rock shaft	1
11	GB66001	Screw M2.5 x3	2
12	8A5 - 014	Collar	2
13	BS30011	Set screw M5 x12	2
14	BQ10048	Washer	2
15	8A5 - 035E2	Thread guide spring	1
16	43T5 - 001A1b	Ball stud	1
17	43T5 - 001A1a3	Screw	2
18	65T5 - 002	Thread guide tube	1
19	GB66015	Screw M4 x8	2
20	BQ10008	Washer	2
21	8A5 - 033D	Looper thread take - up cam assy.	1
22	GB74015	Set screw M5 x0.5 x4	2
23	8A5 - 034	Bracket for cam holder	1
24	GB66015	Screw M4 x8	2
25	GB29001	Screw M3 x5	2
26	BQ10001	Washer	2
27	8A5 - 035E1	Cam holder	1
28	8A5 - 035E3	Tension stud	1
29	8A2 - 068	Tension disc	2
30	BQ10025	Washer	1
31	8A5 - 035E5	Tension spring	1
32	8A5 - 035E4	Tension nut	1
33	8A5 - 036F	Upper thread guide bracket assy.	1
	8A5 - 036F1	Upper thread guide bracket	1
	8A5 - 036F2	Pin	1
34	GB29002	Screw M3 x6	1
35	8A5 - 037	Upper thread guide	1
36	GB29002	Screw M3 x6	1
37	BQ10002	Washer	1
38	8A5 - 038	Lower thread guide	1
39	GB65002	Screw M3 x4	2
40	BQ10002	Washer	2
41	8A5 - 039	Thread guard ring	2
42	116T5 - 008	Oil guard plate	1
43	116T5 - 010	Bottom thread guide plate	1
44	BQ10008	Washer	1
45	GB66013	Screw M4 x6	1
46	GB29009	Screw M5 x0.5 x8	1

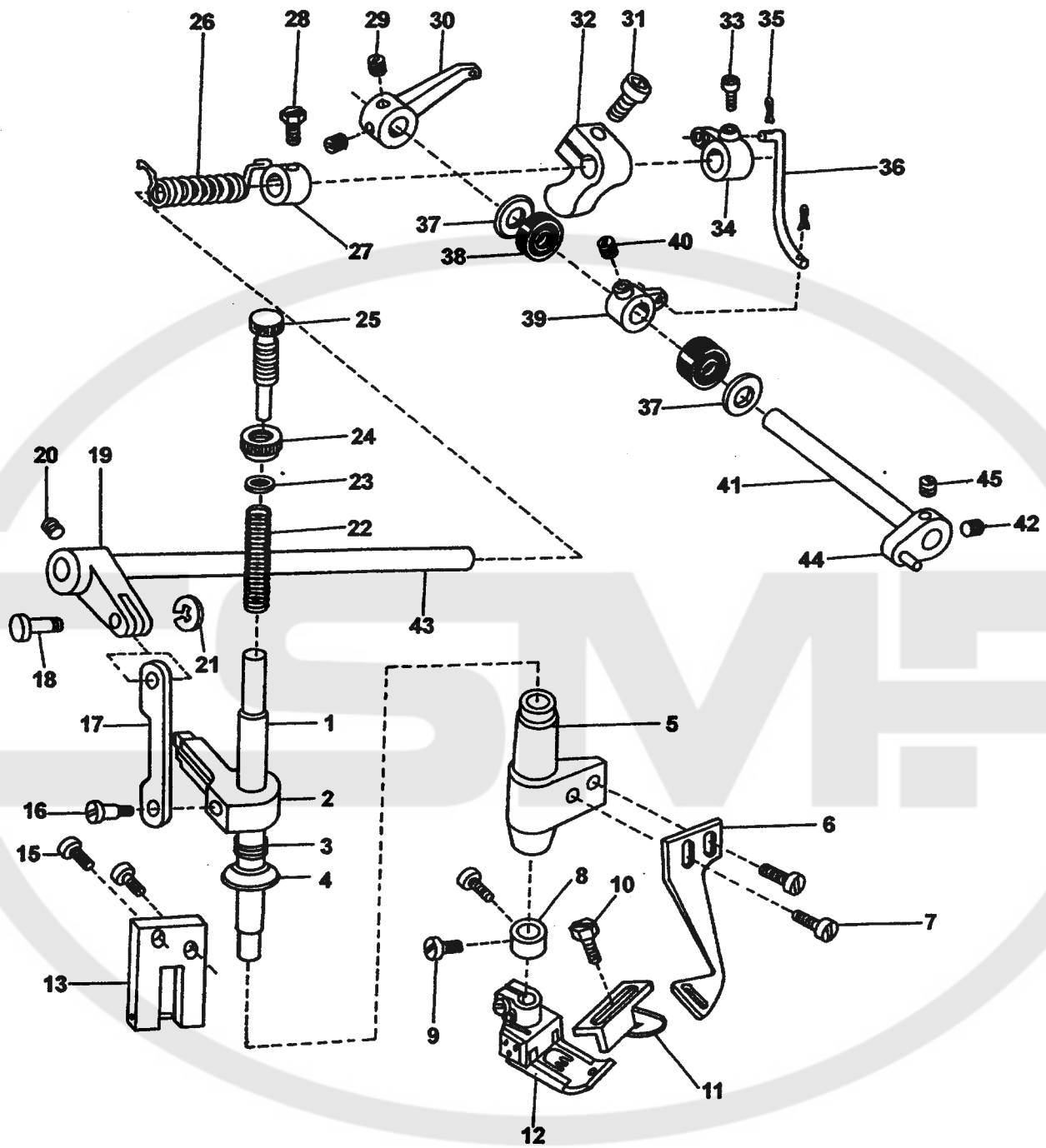

### 13. Presser foot Mechanism

No.	Ref. No.	Description	QT.
1	8A6 -002	Presser bar	1
2	43T6 -008	Stopper	1
3	43T6 -006	Oil guard washer spring	1
4	43T6 -005	Oil guard washer	1
5	43T6 -004	Presser bar collar	1
6	8A2 -044	Thread guide	1
7	43T3 -022	Screw M3 x6.5	2
8	8A6 -003	Collar	1
9	BS10002	Screw M3.5 x5	2
10	116T6 -002A3	Screw	1
11	116T6 -002A2	Upper fabric guide	1
12	116T6 -002A	Presser foot assy.	1
13	43T6 -021F	Presser foot stopper guide assy.	1
14	43T6 -007	Washer	1
15	GB66018	Screw M4 x14	2
16	43T6 -009	Screw M5 x0.5 x14	1
17	43T6 -012B1	Presser foot lifter link	1
18	43T6 +012B2	Pin	1
19	43T6 -012B3	Front crank	1
20	GB74019	Screw	1
21	GB896 -76	Pin clamp	1
22	8A6 -021	Presser spring	1
23	BQ10017	Washer	1
24	116T6 -004	Nut	1
25	8A6 -020	Presser regulating thumb screw	1
26	8A6 -008	Spring	1
27	8A6 -009	Collar	1
28	BS30005	Set screw M6 x8	1
29	GB74030	Set screw M6 x8	2
30	8A6 -019	Presser foot lifter lever	1
31	BS30010	Set screw M5 x10	1
32	43T6 -015	Positioning crank	1
33	GB70001	Set screw M4 x10	1
34	8A6 -011	Presser foot lift crank	1
35	GB91 -76	Cotter pin	2
36	8A6 -012	Connecting rod	1
37	BQ10045	Washer	2
38	8A6 -015B	Oil seal assy.	2
	8A6 -016	Spring	2
39	8A6 -013	Inner Presser foot lifter lever	1
40	GB74030	Set screw M6 x8	1
41	116T6 -001	Thread tension release shaft	1
42	GB74015	Screw M5 x0.5 x4	1
43	8A6 -007	Presser foot lifter shaft	1
44	8A6 -017	Thread tension release lever assy.	1
	8A6 -018	Pin	1
45	GB74017	Screw M5 x0.5 x5	1

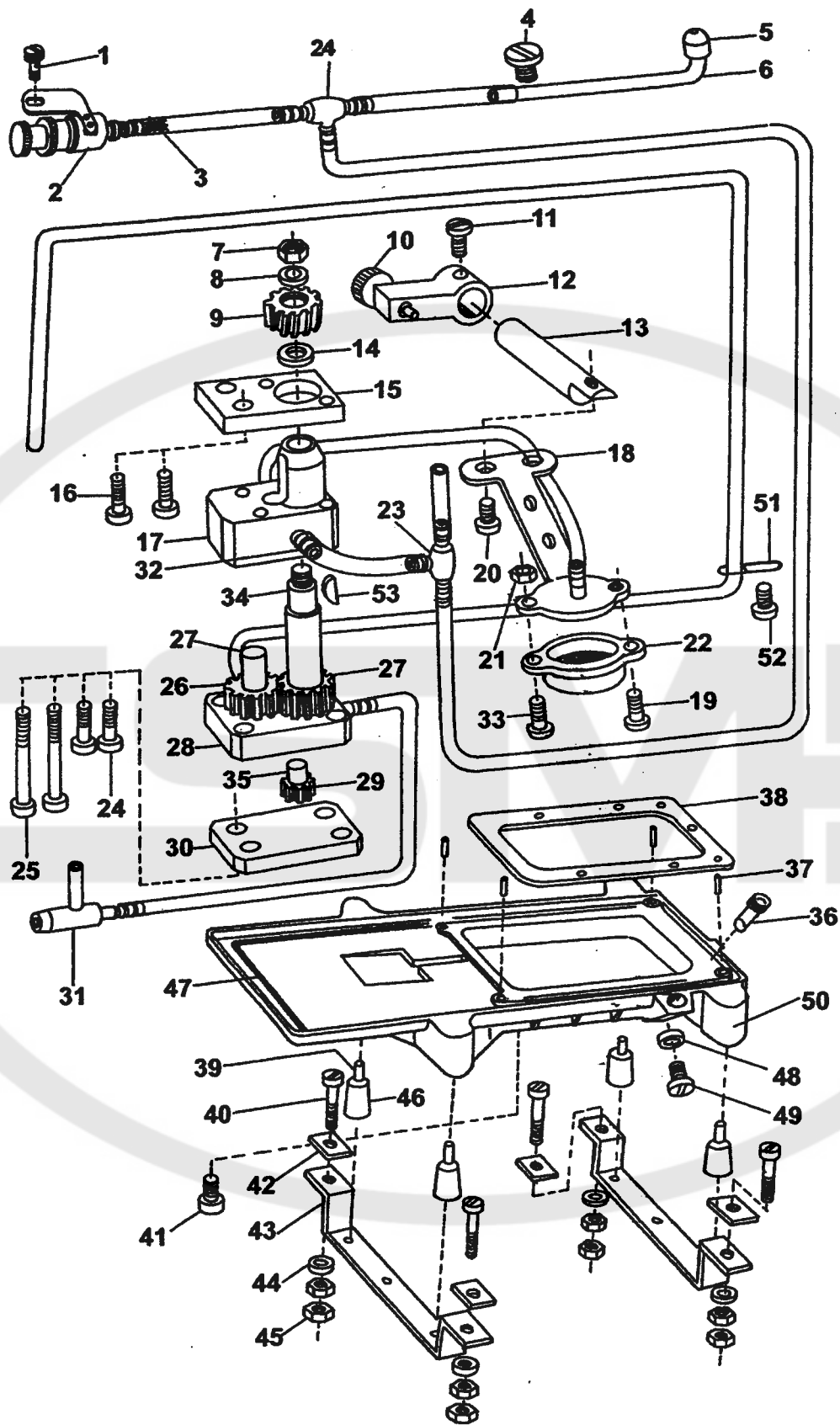

## 14. Lubrication Mechanism

No.	Ref. No.	Description	QT.
1	GB66013	Screw M4 x6	1
2	116T3 -014F	Oil valve	1
3	116T3 -012	Oil wick $\Phi 4 \times 15$	2
4	BS10029	Screw M5 x10	1
5	116T3 -009D1	Oil nozzle	1
6	116T3 -009D2	Oil pipe	1
7	GB52004	Nut	1
8	43T7 -025A5	Washer	1
9	43T7 -025A4	Helical gear	1
10	116T3 -006C2	Adjusting screw	1
11	GB74008	Set screw	1
12	116T3 -006C1	Adjusting wrench	1
13	116T3 -004	Oil filter holder shaft	1
14	43T7 -025A2	Lower washer	1
15	116T3 -002	Positioning plate	1
16	GB66023	Screw M5 x12	2
17	116T3 -001A1	Oil pump bracket	1
18	116T3 -003B1a	Oil filter holder assy.	1
19	58T7 -001A3	Set screw	1
20	GB66022	Set screw M5 x10	1
21	GB52002	Nut M4	1
22	58T7 -001A2	Oil filter	1
23	58T7 -004	Oil nozzle	2
24	GB818 -85	Screw M4 x16	2
25	GB818 -85	Screw M4 x32	2
26	43T7 -025A7	Oil pump gear	2
27	116T3 -001A4	Oil pump gear shaft	1
28	116T3 -001A2	Oil absorb	1
29	43T7 -025A10	Oil absorb gear	2
30	116T3 -001A3	Oil pump cover plate	1
31	65T3 -006B	Oil pipe assy.	1
32	22T4 -007C2	Oil pump nozzle	4
33	GB66016	Screw M4 x10	1
34	43T7 -025A1	Oil pump shaft	1
35	116T3 -001A5	Oil pump gear shaft	1
36	8A3 -004	Oil gauge	1
37	116T3 -011E3	Pin	4
38	116T3 -011E2	Oil seal gasket	1
39	8A3 -016	Pin	4
40	8A3 -031	Bolt	4
41	GB70 -85	Screw M6 x16	5
42	8A3 -030	Rubber pad	4
43	65T3 -015C	Holder plate assy.	2
44	BQ10047	Washer	4
45	GB52013	Nut	8
46	8A3 -015	Rubber cushion	4
47	8A3 -006	Oil seal belt	1
48	43T7 -018	Washer	1
49	43T7 -017	Screw	1
50	116T3 -011E1	Oil reservoir	1
51	C32	Oil pipe clamp	1
52	GB66012	Screw M4 x5	1
53	43T7 -025A3	Helical gear key	1

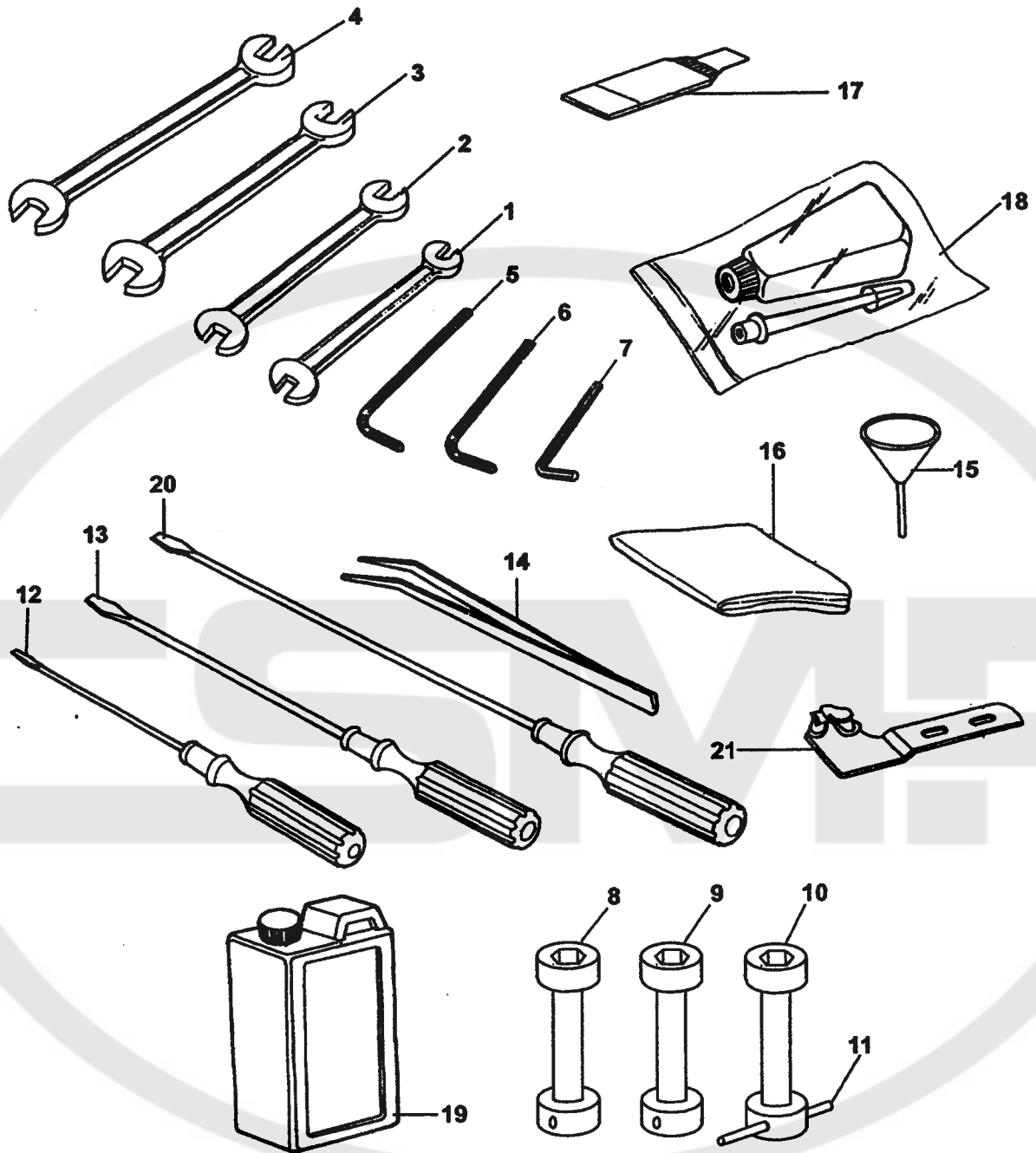

## 15. Accessories

No.	Ref. No.	Description	QT.
1		Double -end wrench 4 x5	1
2		Double -end wrench 6 x7	1
3		Double -end wrench 8 x10	1
4		Double -end wrench 9 x10	1
5		Allen wrench (5mm)	1
6		Allen wrench (4mm)	1
7		Allen wrench (3mm)	1
8		Socket 10mm	1
9		Socket 7mm	1
10		Socket 8mm	1
11		Hand lever	1
12		Screw driver $\Phi 3 \times 50$	1
13		Screw driver $\Phi 5 \times 140$	1
14		Tweezers	1
15		Funnel	1
16		Machine cover	1
17		Needle	1pack
18	22T9 -011	Oil pot	1
19	22T9 -017	Oil tank	1
20		Screw driver $\Phi 5 \times 250$	1
21	8A1 -040A	Hemming assy.	1

## Three thread interlock chainstitch collar binding machine

### FB 9512 Main specification & applications

Model	Needle quantity	Thread quantity	Stitch Length (mm)	Needle gauge (mm)	Presser foot lift volume (mm)	Needle Type (Gk16)	Hem width (mm)	Speed (S. P. M)
FB 9512	2	3	1.8-3.3	4.5	6	70-90	54 x 20	4000

Model	Application
FB 9512	Available to perform cover stitching, Collar binding & hemming on Garment, Knitted underwear, etc.

### FB 9512 Other general spare parts

No.	Ref. No.	Description	Qt.	No.	Ref. No.	Description	Qt.
1	12A1-0011	Front cover plate sewing desk	1	11	118T1-001	Binder plug	1
2	12T1-003A	Binder assy	1	12	118T1-003	Pin	1
3	SP086A	Trade mark plate	1	13	118T6-001	Collar	1
4	12A2-001	Needle holder	1	14	118T1-002	Dust cover	1
5	12A2-002	Thread guard	1	15	GB66015	Screw	2
6	12A2-004	Needle bar adapter	1	16	BQ10008	Washer	2
7	12A4-001	Feed dog	1	17	118T2-001	Scale plate	1
8	12A4-002	Needle plate	1	19	GB29005	Screw	2
9	12A6-001A	Presser foot assy	1	20	BQ10020	Washer	2
10	11A1-0090	Roller plate assy	1				



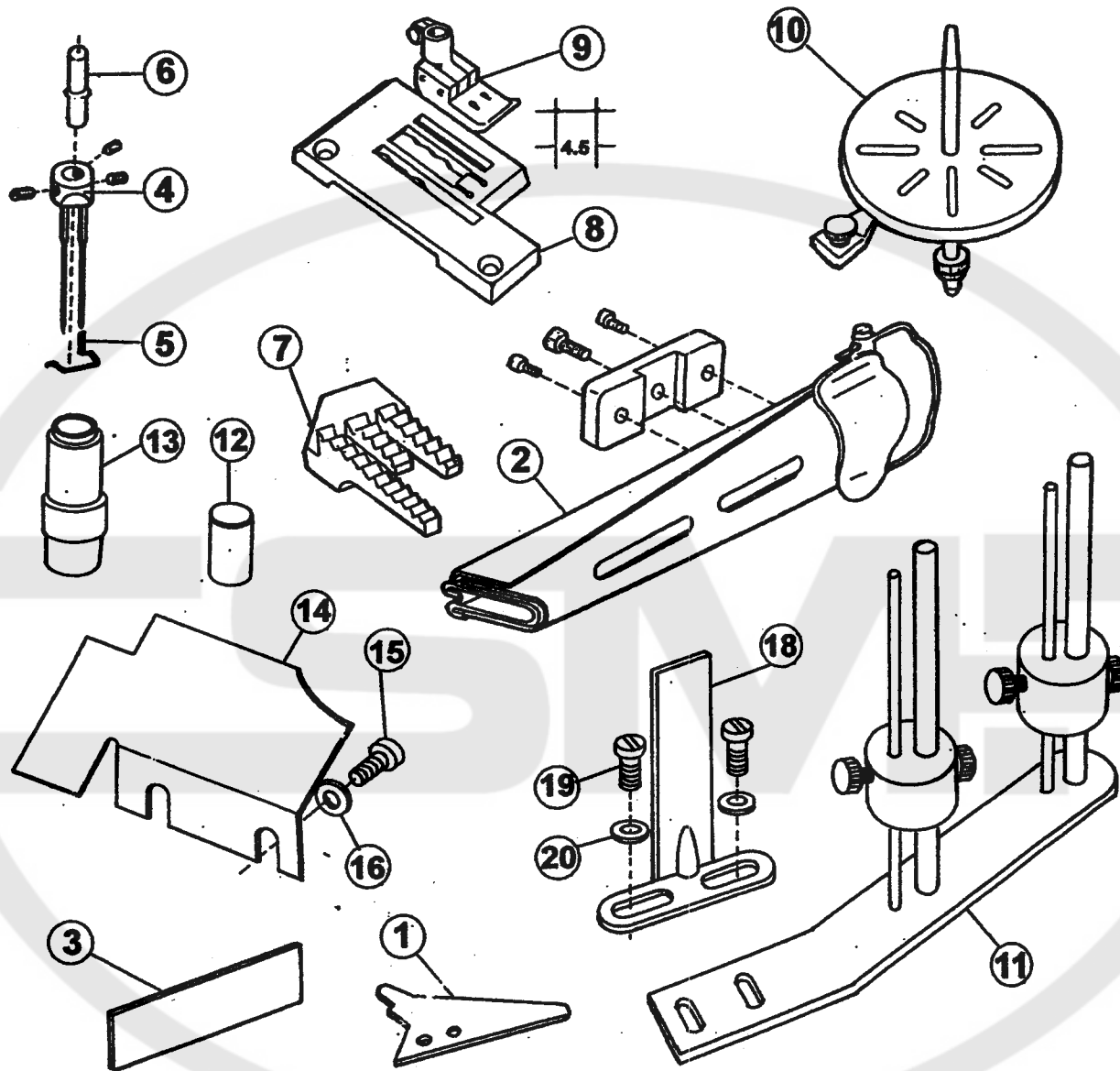

# FB 9513 Three Thread Interlock Chainstitch Collar Binding Machine

## Main Specification & Applications

Model	Needle	Thread	Stitch Length (mm)	Needle gauge (mm)	Differential Rate	Foot Lift (mm)	Needle Type (Gk16)	Hem Width (mm)	Speed (S. P. M)
FB 9513	3	5	1.8-3.3	3.3(6)	0.8-1.2	6	70	54 x20	4000

Model	Applications
FB 9513	Available to perform cover stitching, Collar binding & hemming on Garment. Knitted underwear, etc.

## FB 9513 Other General Spare Parts

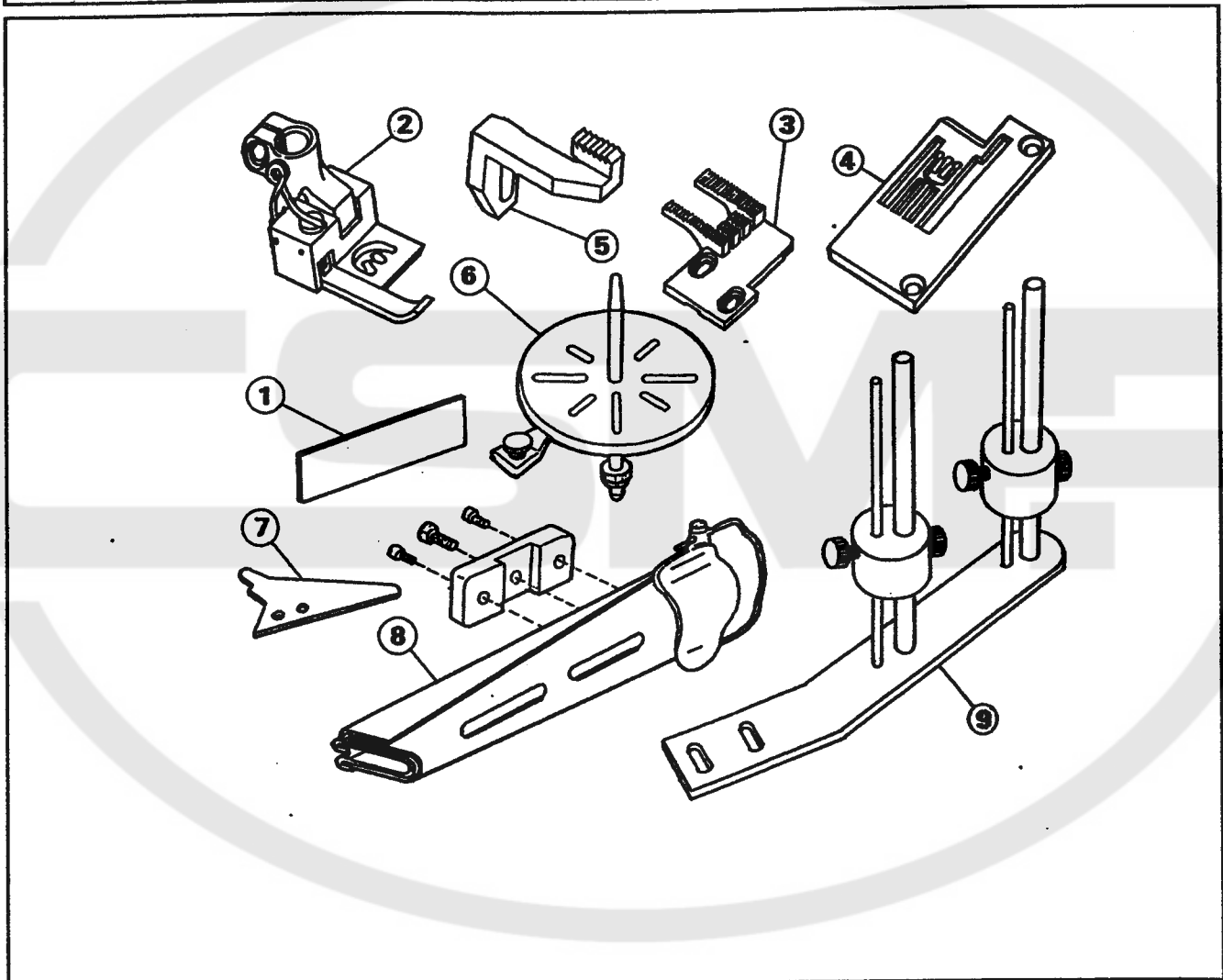

No.	Ref. No.	Description	QT.	No.	Ref. No.	Description	QT.
1	SP085A	Trade mark plate	1	6	11A1-009D	Roller plate assy.	1
2	107T6-001A	Presser foot assy.	1	7	12A1-001	Front Cover plate sewing desk	1
3	107T4-002	Feed dog	1	8	12A1-003A	Binder	1
4	107T4-001	Needle plate	1	9	118T1-001A	Binder plug	1
5	107T4-003	Differential feed dog	1				