

GLOBAL

INDUSTRIAL SEWING MACHINES

MODEL COV 2500 SERIES

CARPET OVEREDGING SEWING MACHINE

**PARTS BOOK
INSTRUCTION MANUAL**

INDEX

Setting up of the machine and lubrication	5
Threading drawing of the lower looper	7
Obtaining correct stitch	9
Cutting device	11
Carpet guide	12
Adjustment of loopers	13
Setting of number of stitches	14
Adjustment of the needle bar	16
Adjustment after replacement of hooks	17
List of chain guides	19
Yarns & Feeddog	23
Presser foot	24
Knives	25
Needles	26

Air cushion table for carpets or blankets .

The dimensions of the table are to be given according to the dimensions of the material.

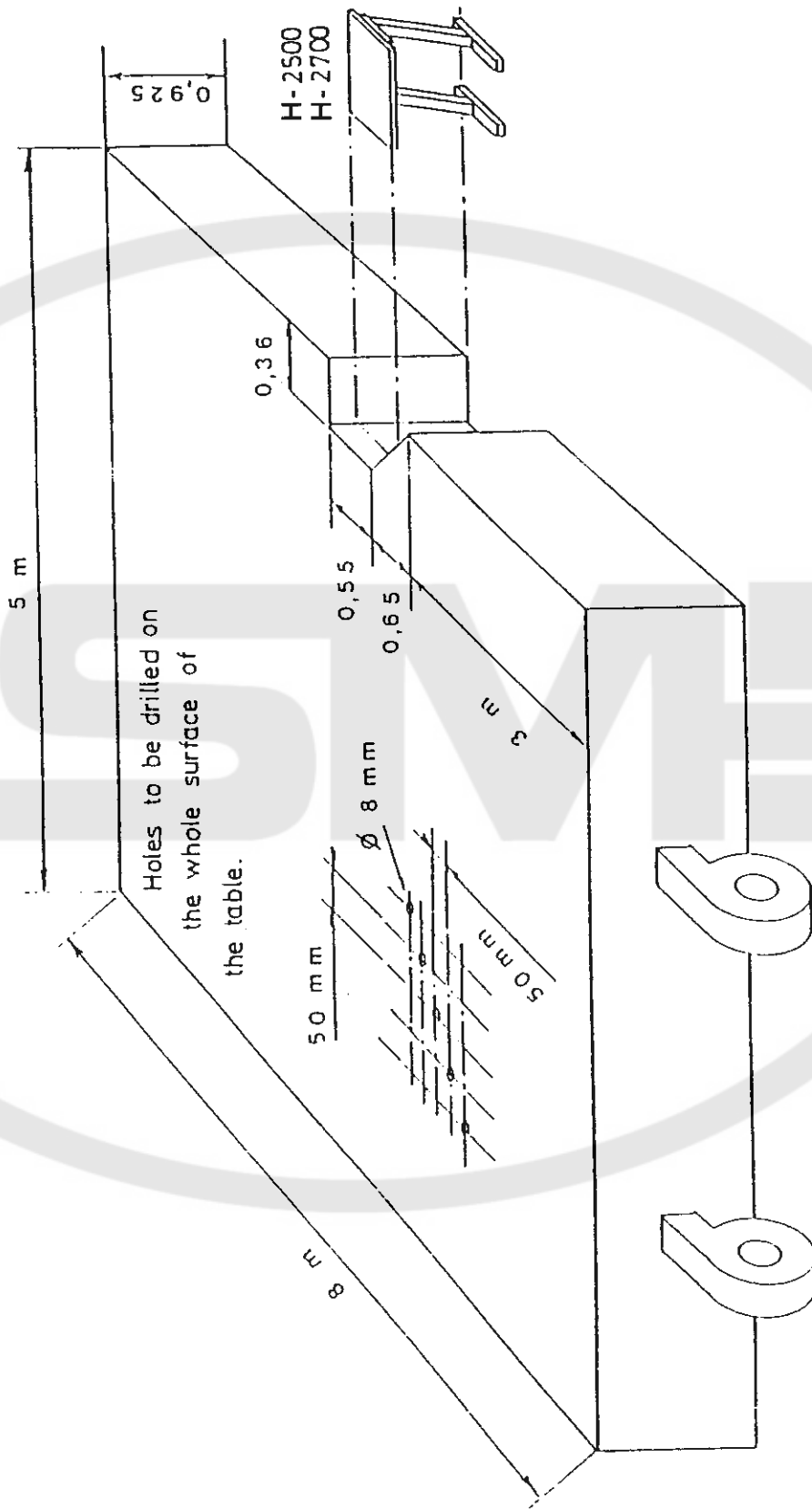

Low pressure blowers of - 2x 1 to 1,5 KW
 - 2x ± 8000 M³ / hour | according to weight of the material.

H-2500

FITTING INSTRUCTION FOR YARN STAND

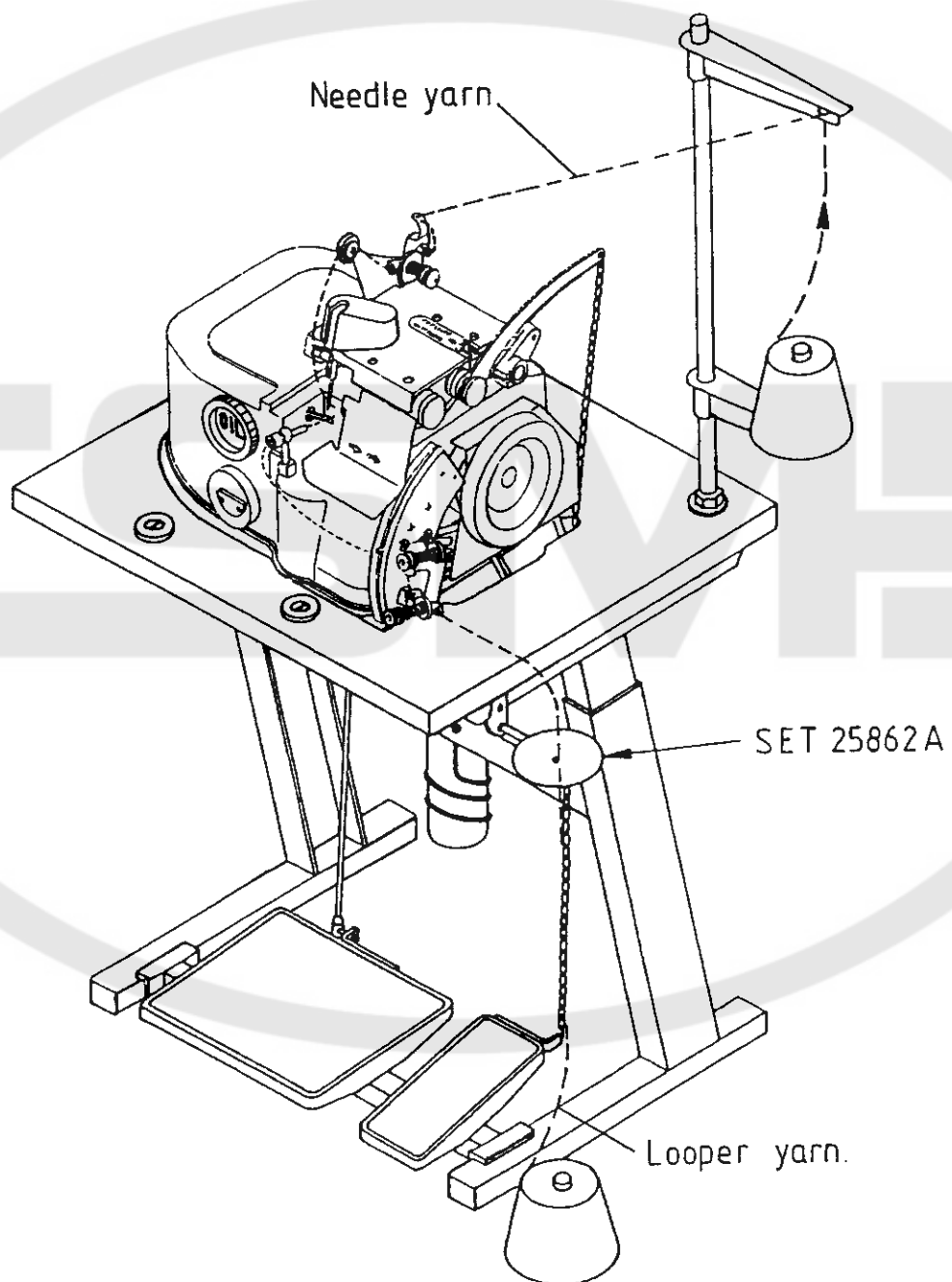
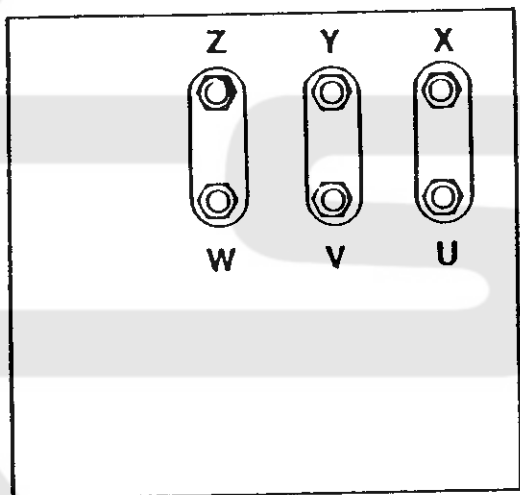
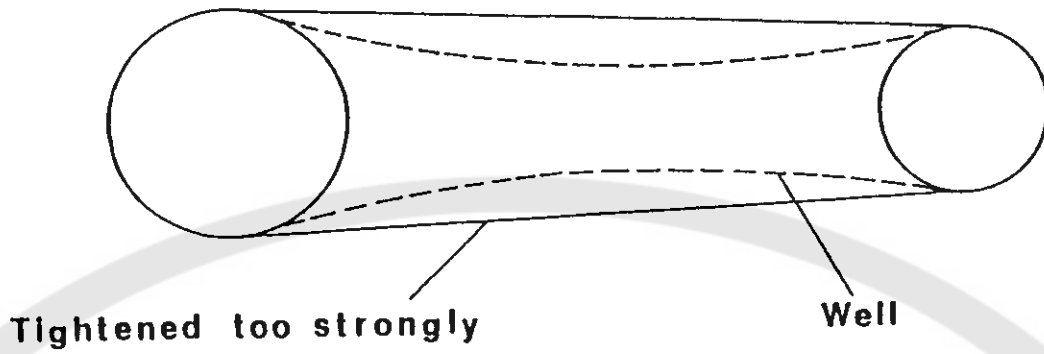
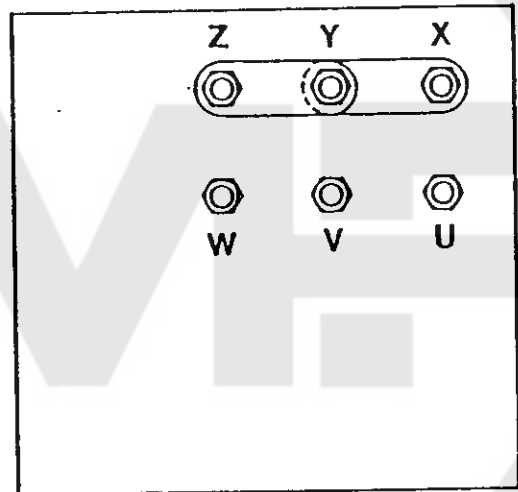

Fig: 1 .



220 VOLT



380 VOLT

Fig:2 .

H-2500

SETTING UP OF THE MACHINE

If the machine is supplied complete, assemble stand, table, motor, pedals and bobbin-holder with the help of the drawing of the manual. All bolts and screws are supplied so that there is no difficulty about it. When the machine has been erected, following controls should be carried out:

1. voltage: motor is always supplied fitted for 380 V. If voltage of network is 220 V, change connections as shown fig. 2 .
2. Driving belt must be tightened slackly. If tightened too strong shafts could be deformed. For a correct belt tension look at fig. 1 .
3. Before starting the machine, check oil level. The gauge must be full. Use only oil having a viscosity of 15W30 either SHELL Tellus 37, BP Energol HLP 46 or any other brand having the same viscosity.

When the machine has been supplied without stand, table or motor, a drawing in the manual will show how to cut out and drill the table top.

The motor must have a power of 1 HP or at least 3/4 HP at 3000 RPM and fitted with a V. belt pulley of 80 mm in diameter.

Afterwards check again a.m. points 1, 2 and 3.

LUBRICATION

The TITAN DK 2500 is a high precision machine. Although many parts move on ball bearings or needle-bearings, high speed makes an abundant lubrication necessary. For this reason the machine has been designed with a splash lubrication. Owing to a very special construction, all parts without exception are abundantly supplied with oil. Of course a little oil will disappear each day from the machine when working. As to enable the operator to check this steady and normal loss of oil, an oil level gauge has been fitted.

The perfect oil level is situated between both arrows printed on the oil level glass.

If there is too much oil leak, maybe one of the pipes for oil drainage is obstructed. In this case compressed air should be blown into the hole of the oil plug, to avoid the stopping up of the pipes. Then you will have enough pressure inside the machine to unstop the oil drainage pipes.

THREADING DIAGRAM

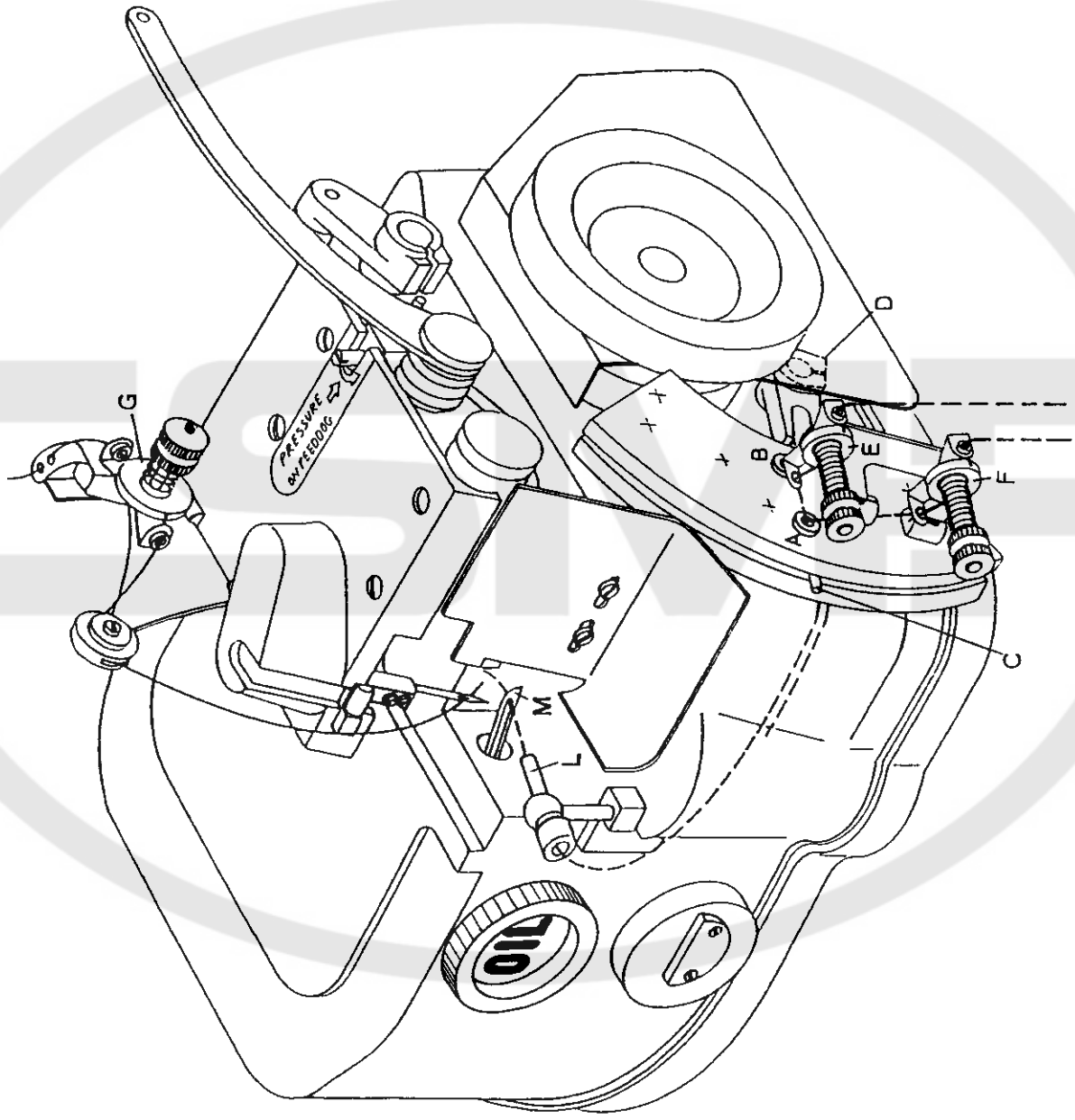

H-2500

THREADING DRAWING FOR THE LOWER LOOPER

In order to thread the yarn of the lower looper (M-fig:3.) one proceeds as follows: the motor is stopped, as soon as it has run out completely, the flywheel is rotated by hand until the take up (C-fig:3.) is very exactly in its lowest neutral position, so that the eye of the lower looper stands exactly opposite the leading tube (L-fig:3). Yarn remainders, if any are removed from the leading tube, the threading needle is taken and the yarn is put in the fork, which is situated in front of the needle, and the yarn is glided through the tube (L-fig:3) exactly to the eye of the lower hook (M-fig:3).

The threading needle is taken back and some yarn is still pressed in the threading tube so that there is a small clew of yarn behind the eye of the lower looper (M-fig:3).

Never forget to remove the threading needle.

Rotate several times by hand until the yarn appears above the throat plate and the stitch has taken its normal shape.

It is possible to thread the lower looper with one or several yarns.

Fig: 4

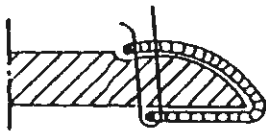

Fig: 5

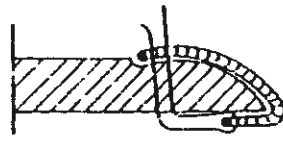

Fig: 6

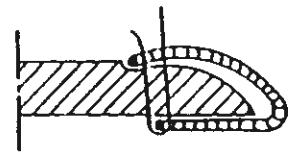

Fig: 7

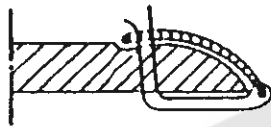

Fig: 8

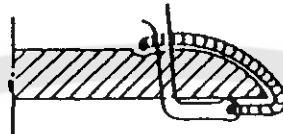

Fig: 9

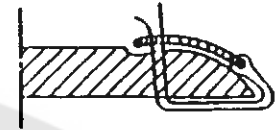

Fig: 11

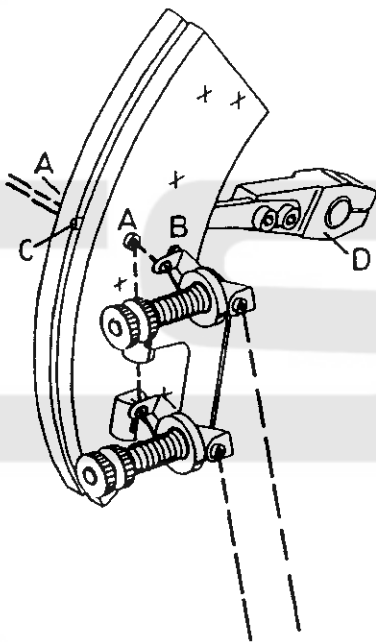

Fig: 10

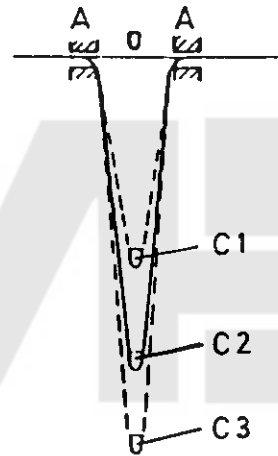
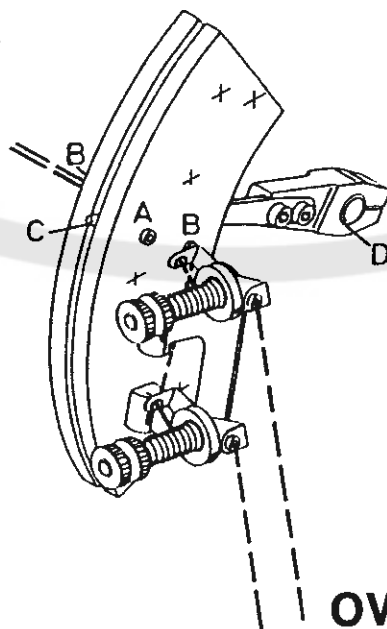

Fig: 12



H-2500

OVEREDGING MACHINE

OBTAINING CORRECT STITCH

To obtain a correct stitch (fig.4) tension regulating discs G, E and F (fig:3) are not very important.

They only restrain lightly the yarns so that the yarn drawing lever C (fig. 11) will draw a well defined length of yarn.

Therefore it is advisable to tighten the tension regulating discs as slightly as possible.

fig:11

The yarn drawing lever (C) has an alternating movement. While moving down it draws along the yarn, which slips freely through the threading holes A. So a defined length of yarn is placed at the disposal of the upperlooper. If the lever is well adjusted, the length of yarn drawn will exactly be sufficient to surround the carpet edge, according to the width of stitch (fig. 4 and C 2 fig: 10 .)

fig:10

If length of yarn draw is not sufficient (fig. 5 and C1), the tension of the needle thread and the tension of the looper thread will not be balanced. Consequently the needle thread will be drawn too far out of the carpet backside.

fig:10.

If the yarn drawing lever draws too much yarn (fig. 6 and C3), then the looper thread surrounding the carpet edge will be slack, instead of keeping close to it.

fig:11.

To carry out this adjustment, loosen slightly screw D of the lever, then put lever in the right position and tighten screw again.

To obtain a stitchdesign as shown on fig. 7 , it is generally sufficient to drive the thread along the threading holes (B-fig.12).

According to the nature of yarn and material which are used, an additional adjustment of the tension discs might have to be carried out.

Fig. 7: The stitch is correct and there is a good balance between the needle yarn and looper yarn.

Fig. 8: The tension on the looper yarn is too low, or that on the needle yarn too high.

Fig. 9: The tension on the looper yarn is too high, or that on the needle yarn too low.

STITCH ADJUSTMENT (Option)

When stitch is set according to the instructions one can proceed to an accurate adjustment with the set of parts showed on fig. opposite.

When thread is passing through thread eyelet "a", output of yarn can be either reduced by turning disc n° 25791 towards "-" or increased by turning towards "+".

When eyelet "b" is used, same result can be obtained by turning in the opposite directions.

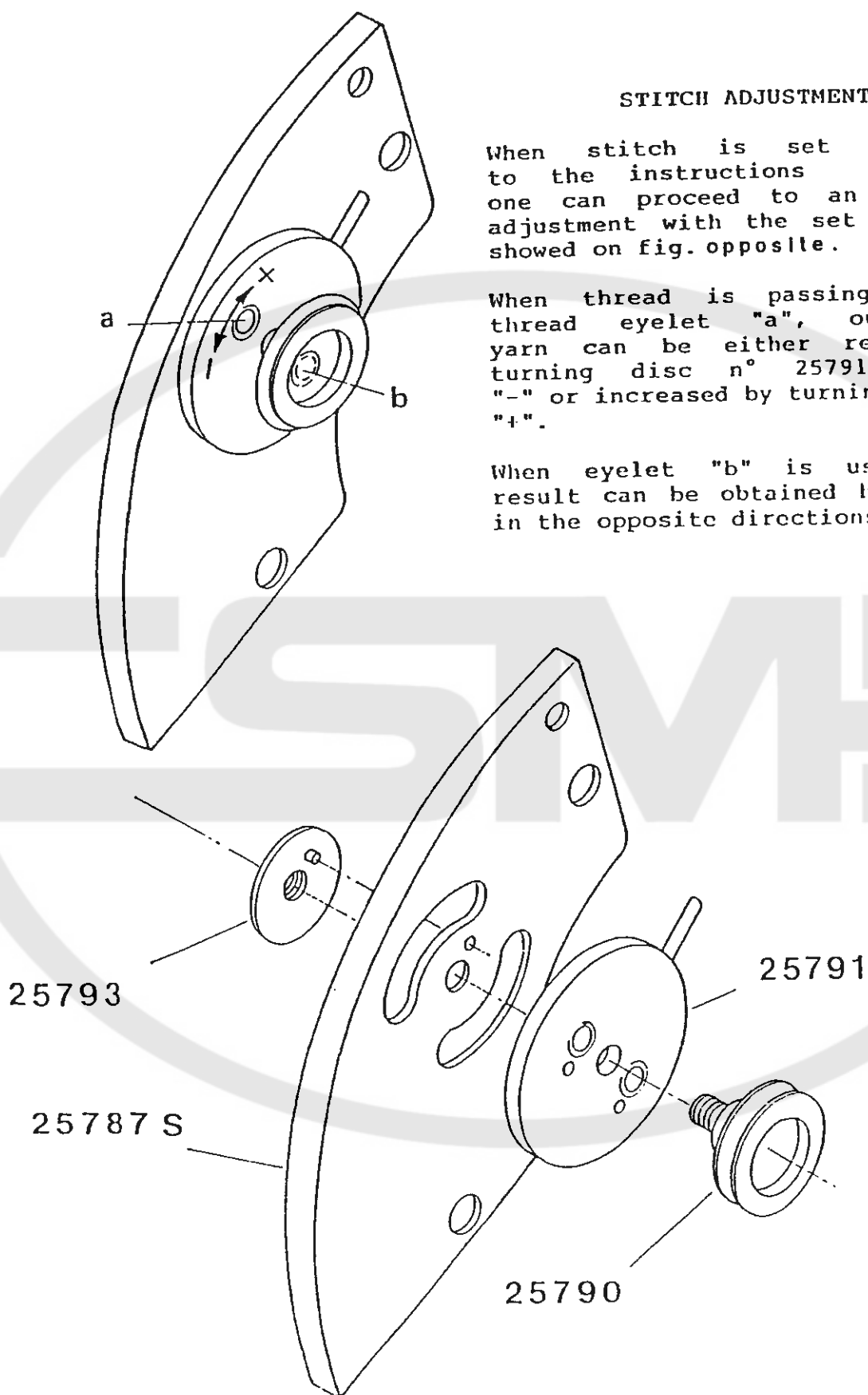

CUTTING DEVICE

Both knives of the TITAN overedging machine are lined with tungsten carbid. They can work for 3 months without being sharpened, if following directions are strictly observed:

When knives must be replaced, take good care that there will be no dirt or plush between fastening surfaces of knives and knives holders.
A few plushes only may cause the knives to be irremediably destroyed within a short time.

fig: 13

When replacing knives, firstly loosen slightly handscrew C. Then untighten completely screw A of the upper knife without taking it out of its housing.

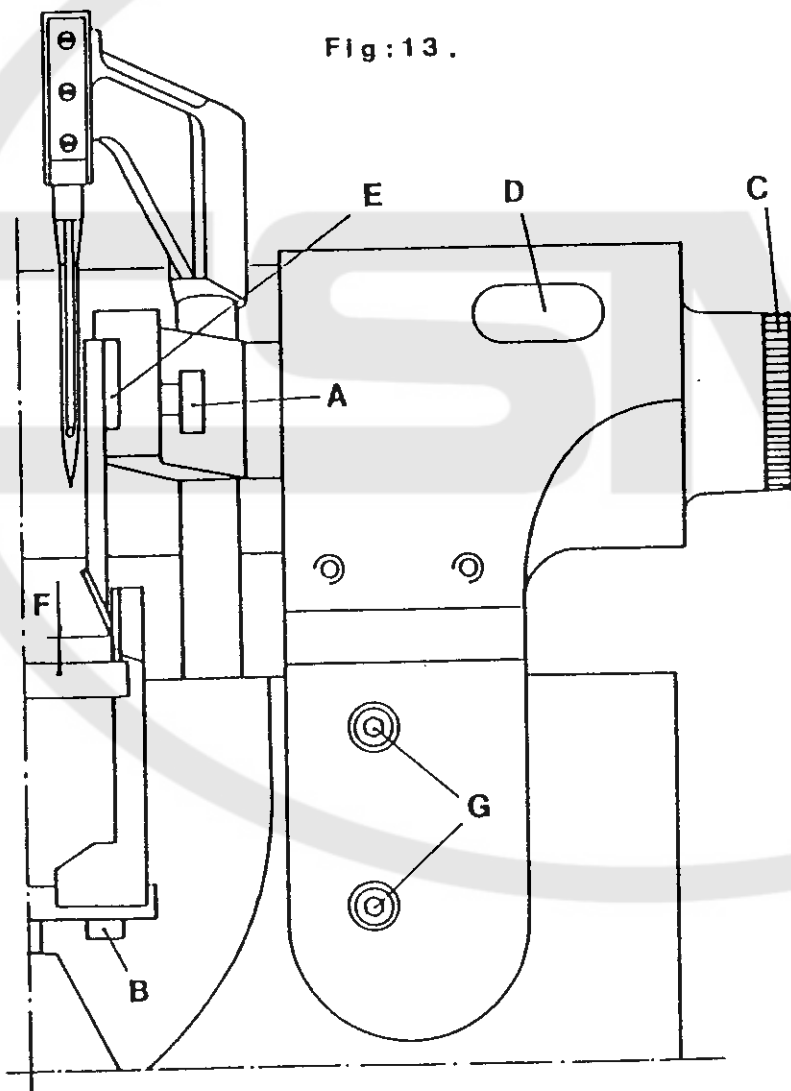

Fig: 13 .

Screw B of the lower knife must be removed completely. Put the new knife exactly at the place of the old one and fasten it with screw B.

Afterwards the upper knife can be put on its place.

When turning handscrew C clockwise, the upper knife comes closer to the lower knife. Both knives must touch, without exerting any pressure on each other

When knives are resharpened some metal is lost and height of knives decreases. For that reason the upper knife must be lowered a little after each sharpening. Carry out this adjustment as follows: take off the protection plate. Loosen screw D and push the knife holder down.

ATTENTION: the cutting edge of the upper knife must be at 3 mm. above needle-plate. (F. fig: 13.) The lower knife (moving knife) may keep its position till many sharpenings have shortened it in such way that the replacement is required.

CARPET GUIDE

When no use is made of the cutting device, or if only a very small strip must be cut off from the carpet edge, then set the guide as shown hereunder.

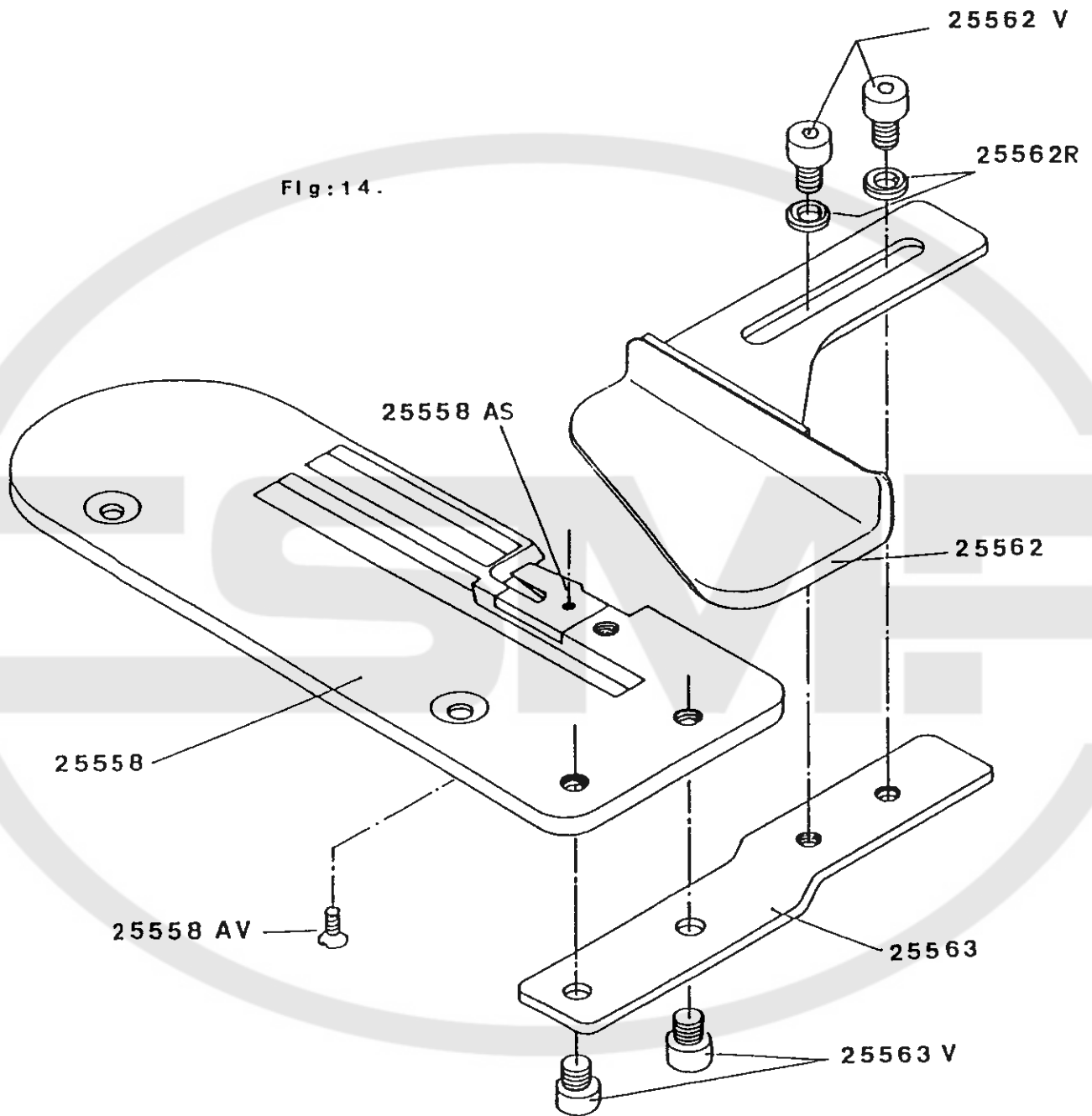

ADJUSTMENT OF LOOPERS

When leaving the factory, the machine is adjusted for using yarns of medium quality and size. If yarns of lower quality are used, a little adjustment will perhaps be necessary. This adjustment will be performed by displacing upper looper C. (fig:15.)

When upper looper is in its highest position, the take up of upper looper C will be situated at 4,5 mm of the needle (fig.15 A).

When using certain types of yarns, this distance might have to be either increased or reduced by 1 mm.

Carry out the adjustment as follows: loosen screws B a little (fig.15) displace looper C, either to the right or to the left.

Fig: 15.

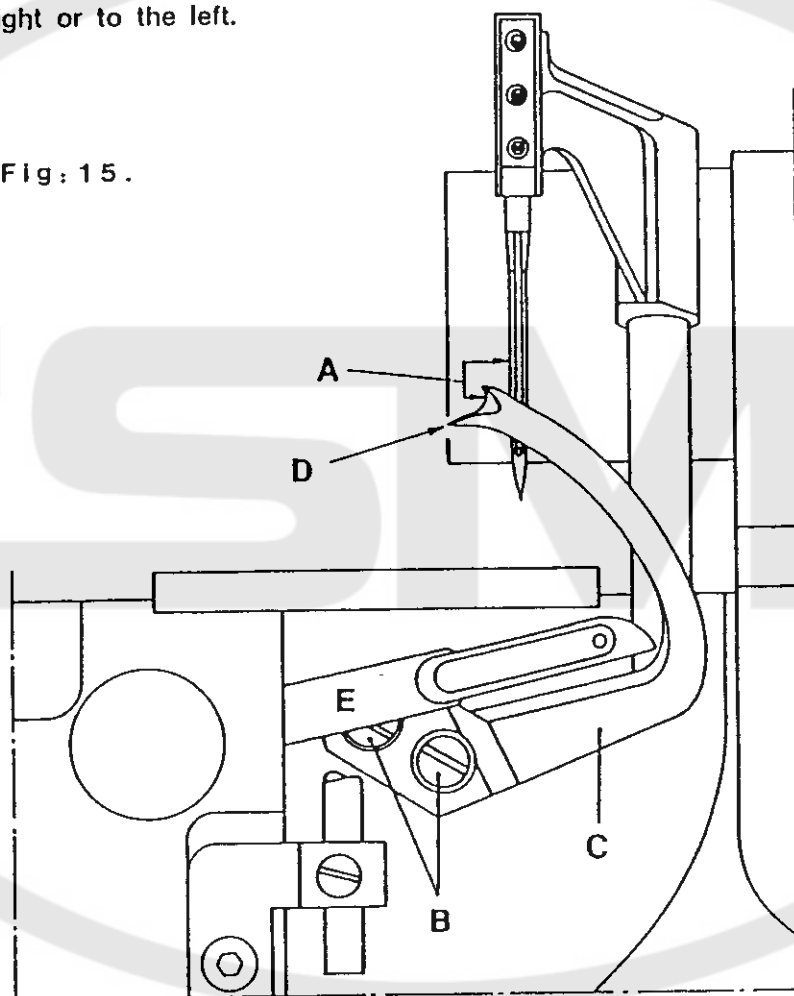

Looper C can only be displaced over a short distance i.e. 1 mm in each direction. When the looper moves towards the needle, it crosses underlooper E (fig.15). At this moment point D of looper C moves in a groove milled in the underlooper E. Take care that E and C do not touch each other.

When this adjustment is performed, refer to § Obtaining correct stitch .

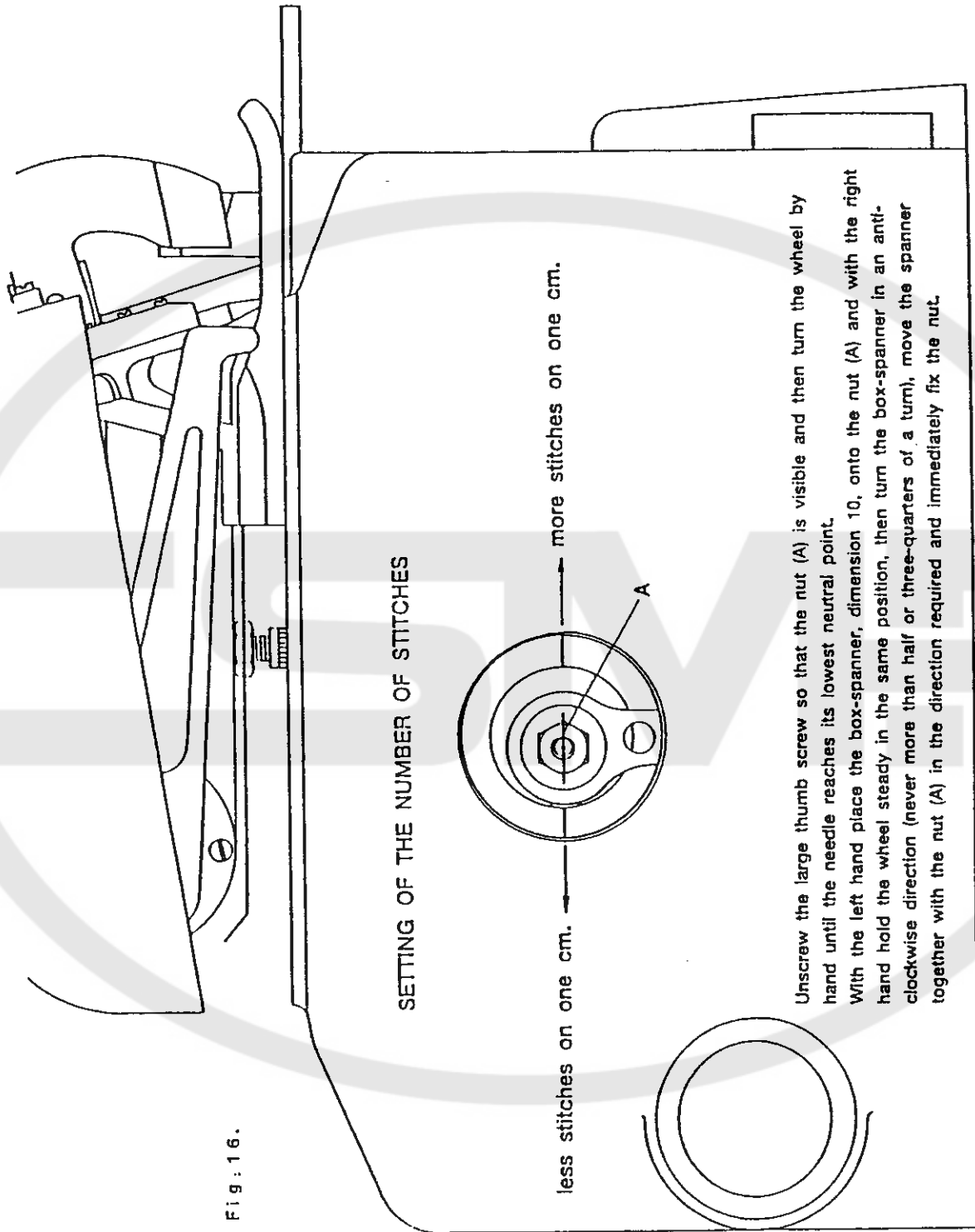
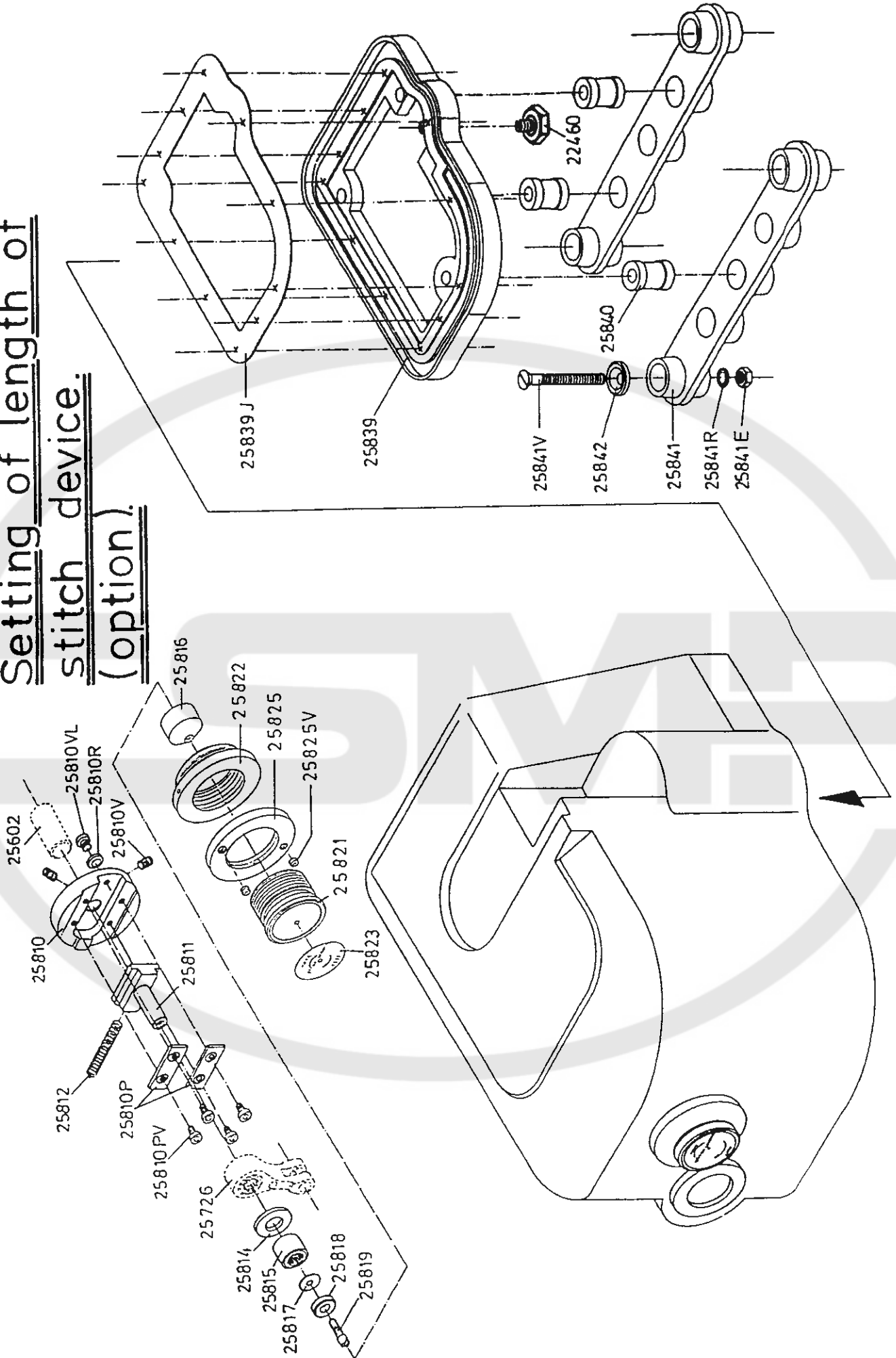

Fig. 16.

OVEREDGING MACHINE

H-2500

Setting of length of stitch device. (option).



ADJUSTMENT OF THE NEEDLE BAR

Untighten both screws A (fig. 18.) so that the needle bar B moves with a certain restraint in the holder C.

Turn the machine wheel by hand until the needle D gets engaged in the slot E of the needle plate I: the point of the needle must be exactly in the centre of the slot E.

During this adjustment, also adjust the height of the needle as follows:

Loosen slightly the screws G and set screw F in such position that it sticks out from its housing by 3 mm. (fig:23.)

Tighten the screw G, place a new needle and fix it with screw H fig. 18 . By turning the machine by hand, the needle-bar reaches its highest neutral point, in this position the distance between the point of the needle and the surface of the needle plate (I) (fig. 23.) should be exactly 23 mm.

For this adjustment move the needle bar B with regard to the holder C (fig. 18), to the height which is required, making sure that the point of the needle is always exactly in the center of the slot E and tighten the screws A.

When the needle reaches its lowest neutral point, it is necessary for the correct formation of the loop of the needle's thread that the needle rises from 1,7 mm to 2 mm before the lower hook is in the position shown by figure 20 .

ADJUSTMENT AFTER REPLACING THE LOWER OR UPPER LOOPER

Loosen both screws G (fig. 13) and remove the complete upper part of the machine, then the needle plate I (fig. 18) and the base plate as well.

REPLACEMENT OF THE LOWER HOOK

Insert a new needle and unscrew the nut K (fig. 18) half a turn.

By turning the machine wheel by hand, position both loopers as shown on fig. 21 ,
unscrew the looper J from its slot N (fig. 18), in an anti-clockwise direction.

Introduce the new looper into the slot N and screw it on the threaded rod L up to the point where the nut is (fig. 18).

Place the surface S of the lower looper exactly parallel to the needle (fig. 24) i.e. at 17°.

Between the countersink of the needle and the surface S of the lower looper, there must be a play of 2/10 to 3/10 mm, more would give rise to false stitches, while less play would give rise to contact between the parts concerned, which should be avoided at all costs.

fig.18

On the surface S place a 6 mm fork spanner and fix the nut K maintaining the 17° angle of the surface S.

Figure 21 shows a measure of 80 mm which must be respected when the lever M (fig.18 has to be moved. For this adjustment, loosen screws R (fig. 18) so that the lever can turn on its axis with a slight restraint; adjust the point of the lower looper at the required measure of 80 mm and tighten the screws R.

REPLACEMENT OF THE UPPER LOOPER

Completely remove the upper part of the machine, and the needle plate I (fig. 18)

Turn the machine wheel by hand until the upper looper V reaches its lowest neutral point (fig. 19). In this position both screws T can be removed and the worn looper replaced by a new one (see ✕). If after this replacement, there is contact made between the upper looper and the lower looper, carry out the following adjustment:

Loosen screws O (fig.18) and move the bronze slot N in the direction which is required (see arrows - fig.17).

ATTENTION: The adjustment must be minimal and should never exceed 1/10 mm. Tighten both screws O.

A similar adjustment can be made by untightening the screw U (fig. 17) and by moving the shank of the swivel joint L in the required direction, with regard to the lever M (fig. 17).

✕ § Adjustment of loopers.

SELECTION OF A CHAIN GUIDE

Depending on the thickness of the carpet to be overedged. In order to obtain a proper stitch, one will fit a chain guide which is suitable to the material.

Hereunder the list of different available guides with their ref. numbers.

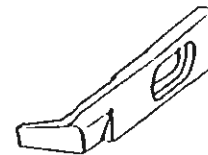

PART NUMBER	LEFT EXECUTION	RIGHT EXECUTION	DESCRIPTION
-25560	X	X	-Normal carpets.
-25560B	X	X	-High piles.
-25560C	X	X	-Blankets.
-25560EE	X	X	-Normal carpets with small overedging.
-30560GR	X	X	-Normal carpets with tape insertion.
-25560H	X	X	-Heavy carpets.
-25560K	X	X	-Butseamer.

SELECTION OF NEEDLE PLATE FINGER

Depending of the fact the yarn of the lower hook is thick or thin it might appear necessary to adapt the needle plate.

For thin yarn and thin material one will use a needle plate with a small groove. For thick yarn and thick material the use of a needle plate with a larger groove will be more suitable.

<p>25558 AEE</p>	<p>25558 AS</p>	<p>25558 AEEK</p>
<p>25558 AC 3,5 K15</p>	<p>25558 AE 2,5 K16</p>	<p>30558 AKS</p>

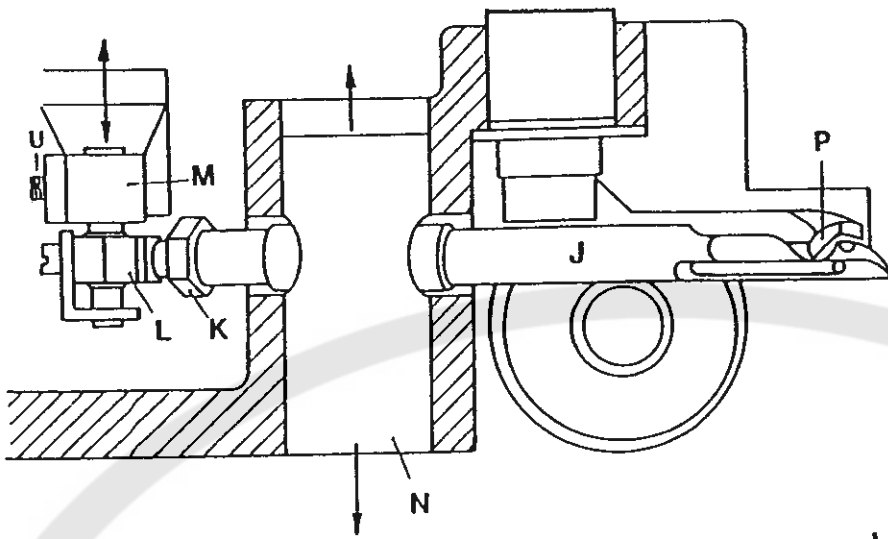

Fig:17.

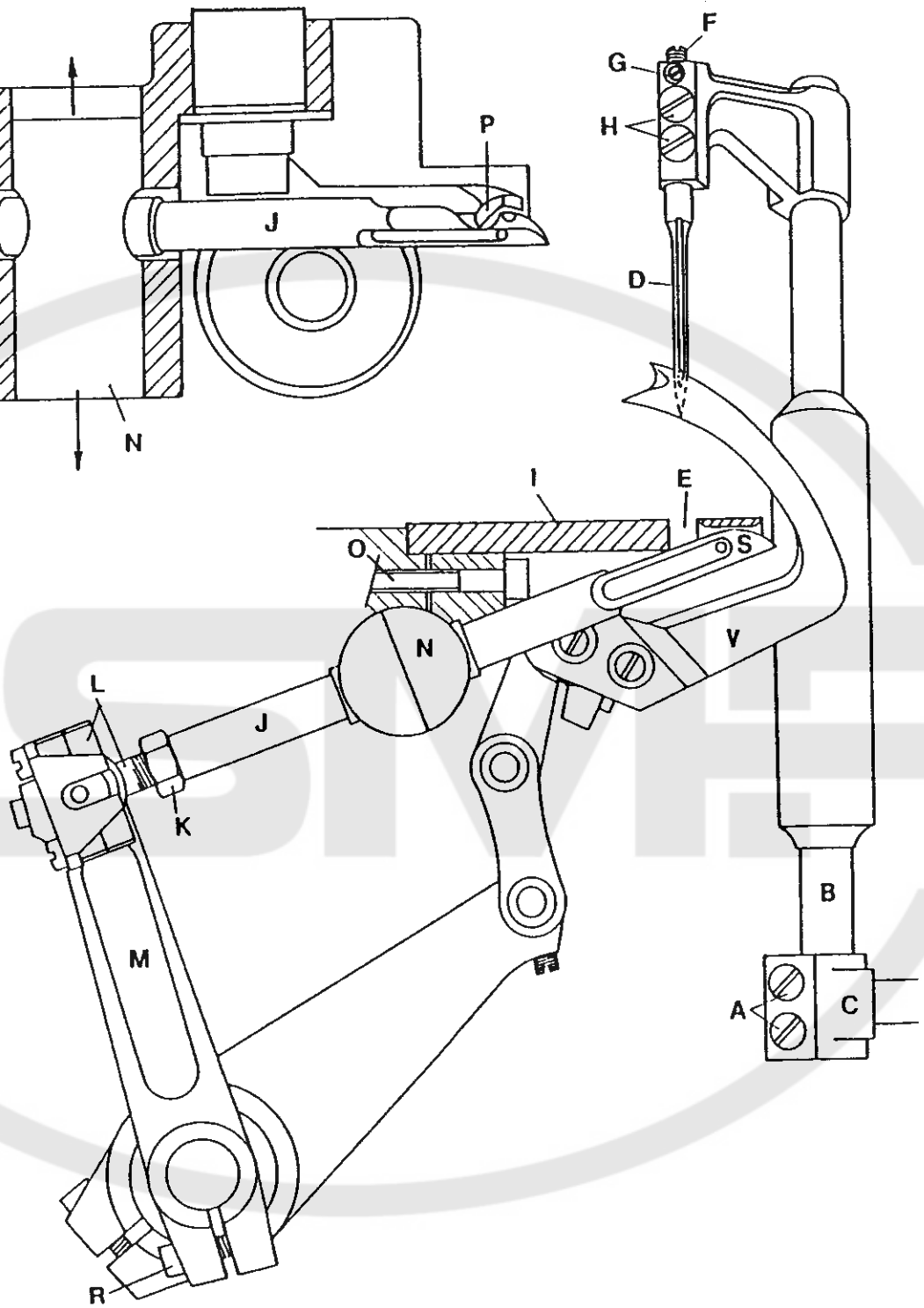

Fig:18.

**H-2500
OVEREDGING MACHINE**

Fig:19.

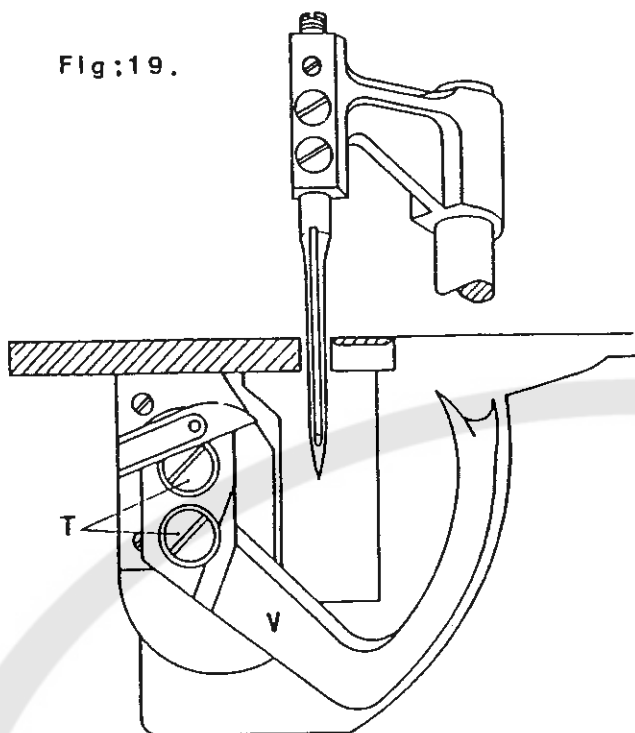

Fig:20.

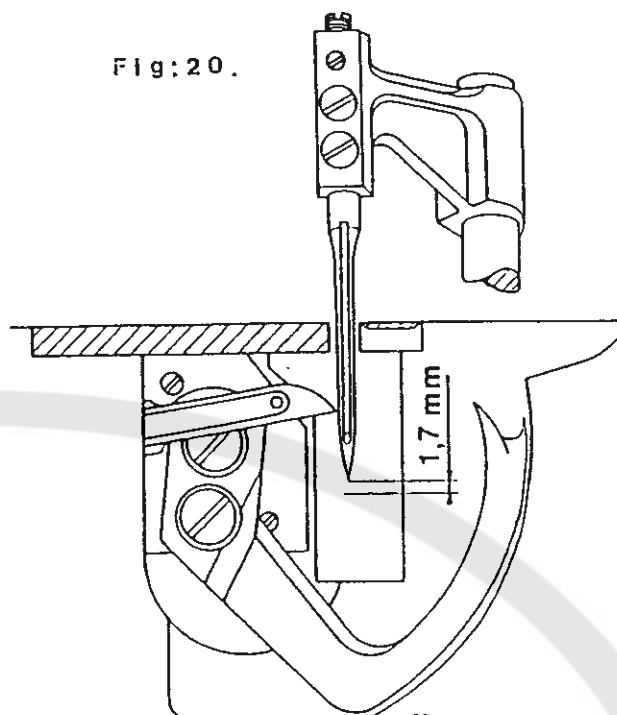

Fig:21.

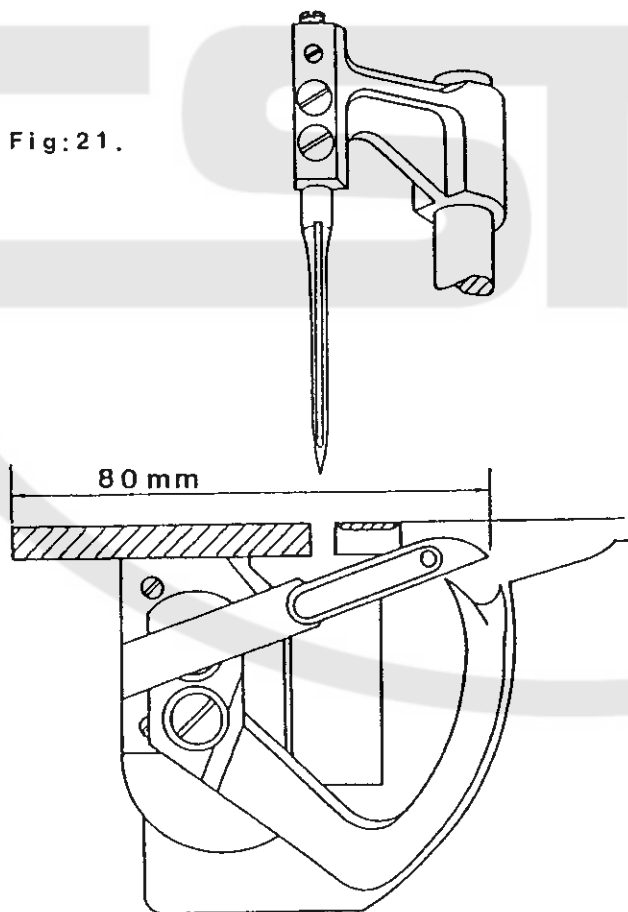
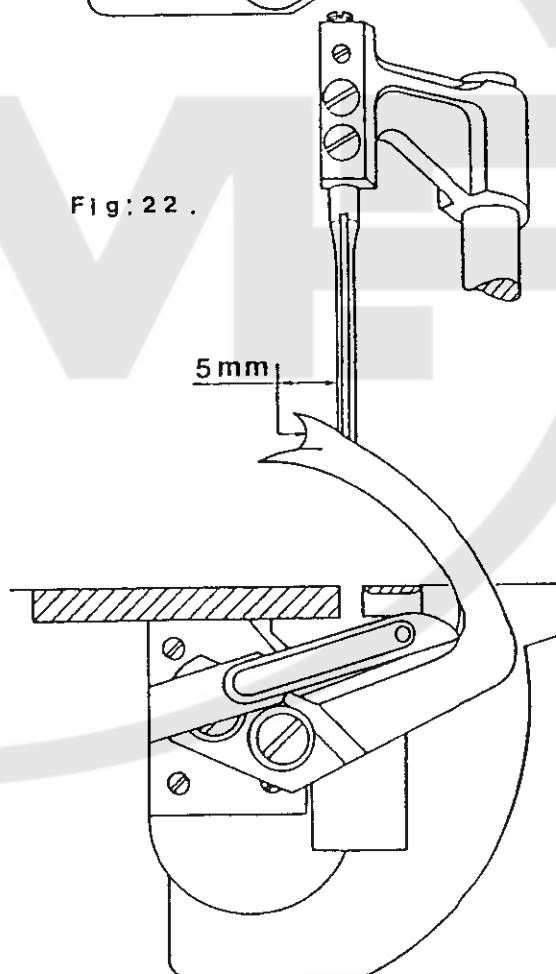

Fig:22.



H-2500

OVEREDGING MACHINE

Fig:23 .

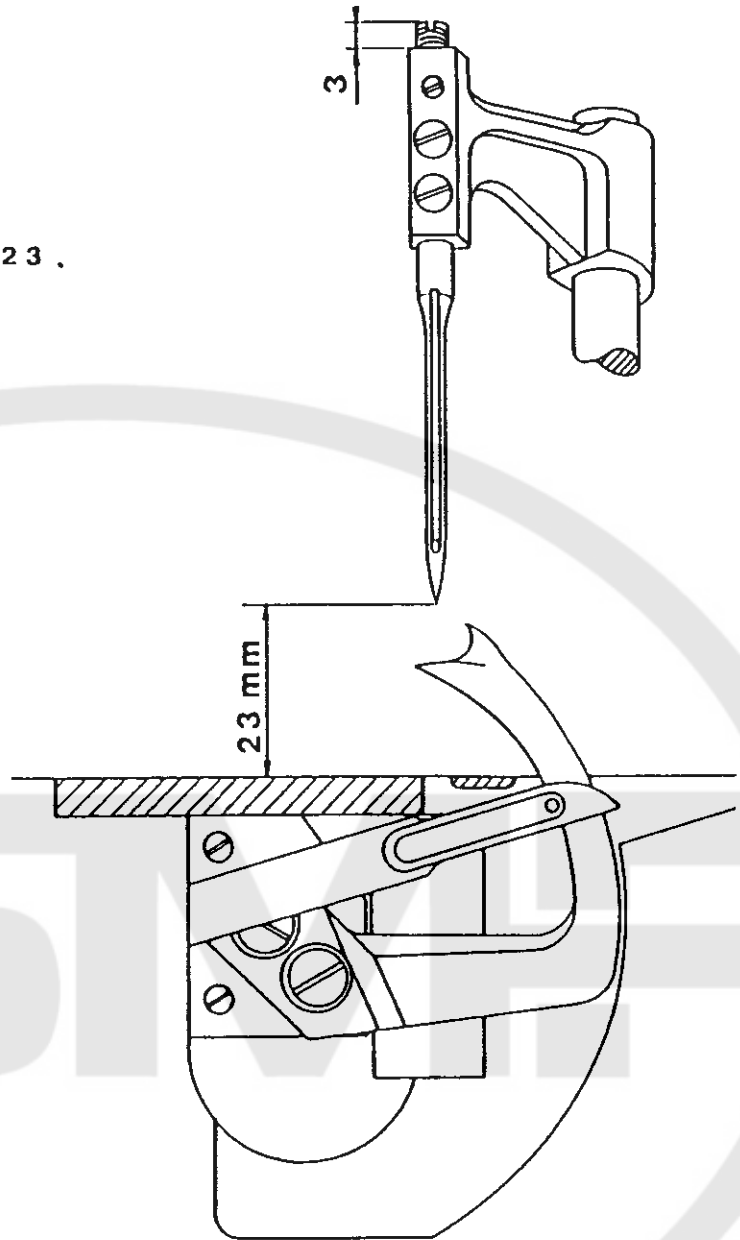
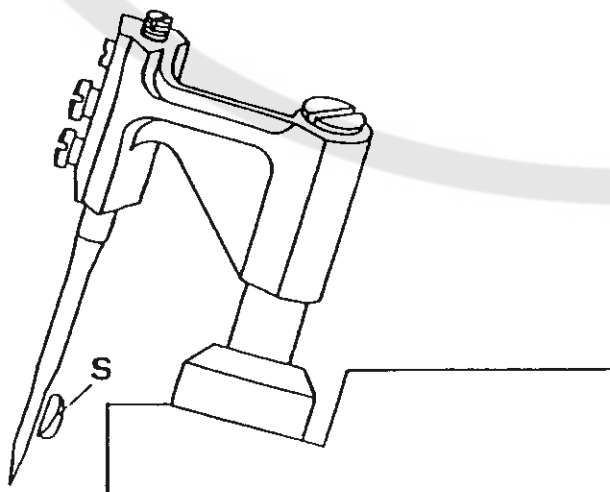

Fig:24 .



H-2500

OVEREDGING MACHINE

YARNS

All types of yarn can be used on the DK 2500. However, for the needle, we recommend using thinner yarns for example, a n° 18-2500 m mercerized cotton from BST or any other brand.

Use preferably 2 or 3 thin yarns for the finishing yarn for tufted carpets. These should be loosely twined with about 10 twists per metre. This is because 2 or 3 and even 4 yarns spread out better and consequently the stitch can be markedly larger than with a single thick and overtwined yarn in the lower looper or hook.

THE FEEDDOG

The sewing of tufted carpets with a needle creates a sort of dust composed of textile and rubber particles.

This dust accumulates every day the machine is used and it becomes more and more compressed by the movement of the feeddog until the feeddog itself finally breaks. This also causes severe overloading of the other parts of the machine. If a powerful compressor is available which delivers air at 6 bar, it suffices to blow the uncompressed dust away every day. Even so the throat plate should be removed at least every two weeks the machine is in operation, in order to remove compressed dirt.

PRESSER FOOT

It is very important to have the correct pressure on the presser foot if the overedging machine is to work well. If the pressure is too low, the feeddog will nevertheless carry the material forward, but this will be very irregular and the feeddog will slide too much on the rough backing of the carpet, causing undue wear on the feeddog. For the same reason the stitches will be irregular and may not be properly formed.

Insufficient pressure on the presser foot when working with tufted carpets with foam backing will lead to the foam being stripped off. If in contrast the pressure is adequate, only light traces will be left by the feeddog on the backing. The most suitable pressure on the presser foot is 8 kg.

This can be checked by means of a standard dynamometer.

Available presser foots.

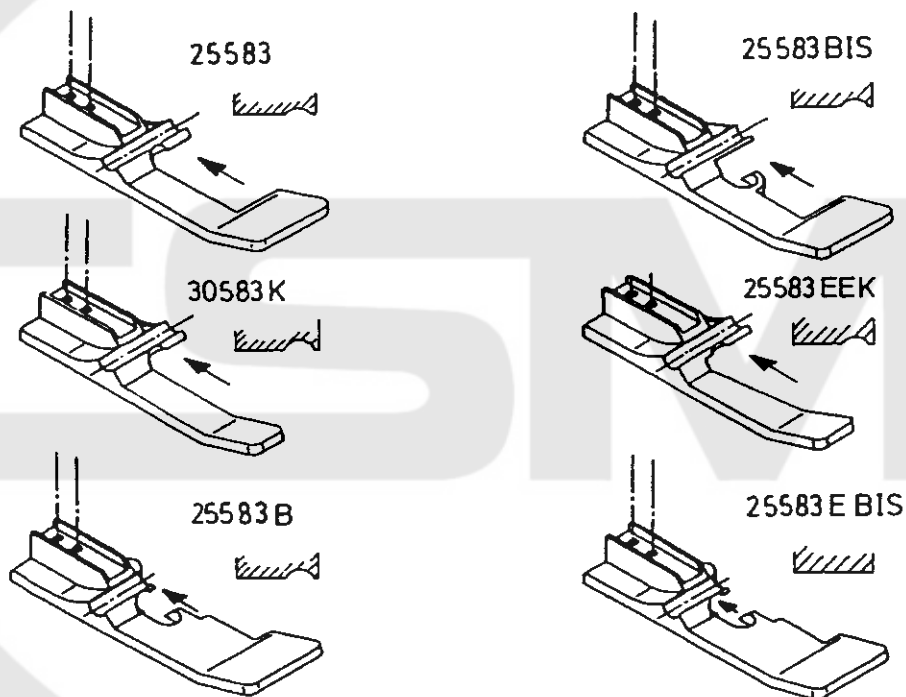

Part number.	Description.
25583.	-Standard foot.
25583BIS	-Fine materials.
30583K	-Blankets -Used in combination with guides.
25583EEK	-Stitch width 5,5 mm.
25583B	-Buttseamer.
25583E BIS	-Buttseamer(fine materials).

KNIVES

The knives are lined with plates in a hard metal (wydia) allowing a service life of about two months. As these plates are extremely hard they are also very brittle, which means that overly sharp contact between the upper and lower knives can cause the cutting edges to shatter.

An adjusting screw is installed on the machine (see fig 13) and this allows the best gap between the knives to be set without risking damage.

Staples are often used in weaving sheds; it should not be forgotten that if a staple ends up between the knives of the DK 2500 the knives will have to be resharpened.

We do not advise trying to sharpen the knives without specialized machinery. We dispose of such equipment so that we can resharpen your knives whenever it is required.

N E E D L E S

Type : 7713/230, 180 or 160
7713-99/230 (square pointed)

Considering the fact that the needle of the DK 2500 machine pierces the carpet 2800 times a minute, it is quite normal that the original shape of the needle is significantly altered after a few days. The recess in the needle which forms the loop in the yarn wears away and this causes false stitches.

If the DK 2500 runs for 8 hours a day, the needle must be at the latest replaced after one week (36 hours) by a new one. The old needle will then have pierced and been withdrawn from the carpet 10 million times.

The needle in the machine may reach a temperature of 450°C causing the foam at the back of tufted carpets to melt and to stick to the needle. This reduces the penetration power of the needle by about 50% and causes severe overloading of the needle drive mechanism and a premature wear of the internal parts of the machine. Therefore we advice to lubricate the needle when sewing rubber-backed carpets. This can be done by allowing the needle yarn bobbin to soak in a parafin oil bath for 24 hours, subsequently allow the bobbin to drip out for some days, after which the yarn can be used. The parafin laden yarns prevent the needle from sticking to the rubber. Parafin oil leaves no stains on the sewn work.

When changing needles you will notice that a ring of dust has been formed around the needle shaft. It is essential that this dust ring is carefully removed BEFORE the change of the needles. If this is not done properly, there is a danger that the dust is pushed into the needle holder, thus causing the original needle distance to be altered by the thickness of the dust layer, which could lead to the stitches not being properly made.

E-CHAIN GUIDE
 NL-KETTINGGELEIDER
 FR-GUIDE -CHAINETTE
 D-FÜHRUNG FÜR KETTENSTICH

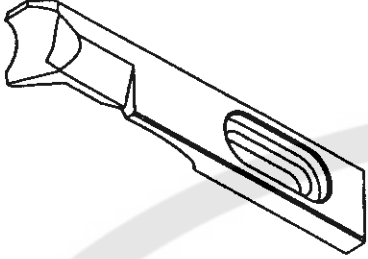
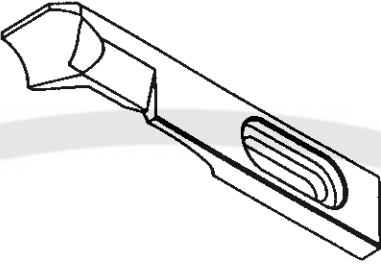
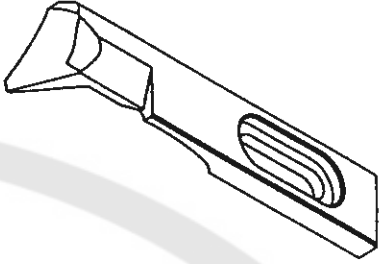
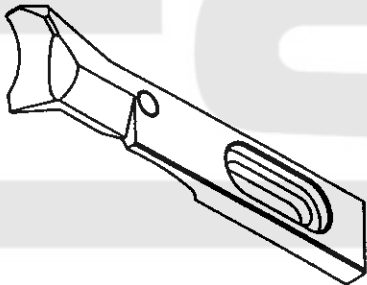
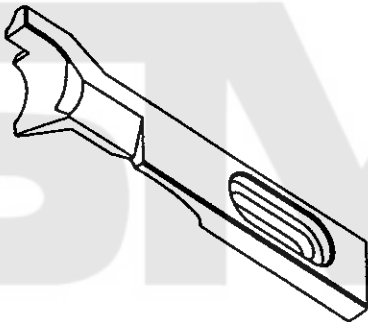
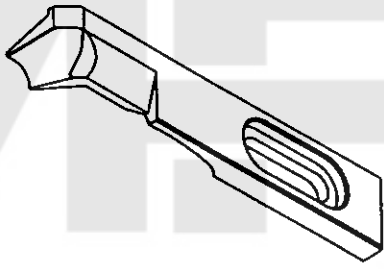
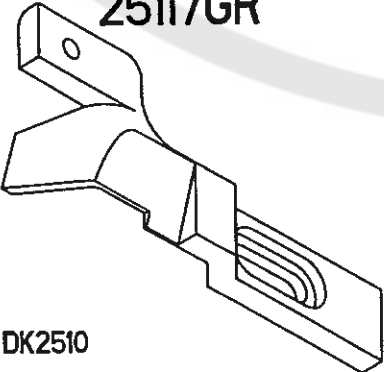
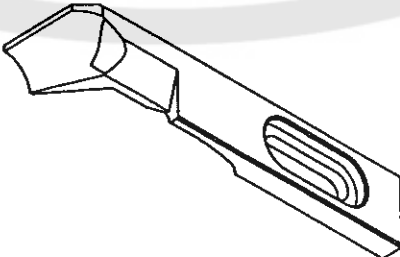
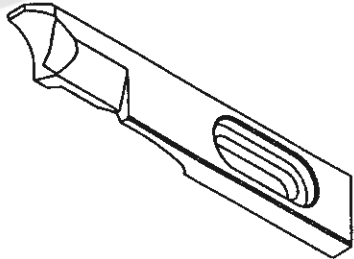
<p style="text-align: center;">25560</p> 	<p style="text-align: center;">25560B</p> 	<p style="text-align: center;">25560CK</p> 
<p>E-STANDARD CARPET NL-STANDAARD TAPIJT FR-TAPIS STANDARD D-STANDARD TEPPICHE</p>	<p>E-STANDARD CARPET HIGH PILE NL-STANDAARD TAPIJT HOGE POOL FR-TAPIS STANDARD POIL HAUT D-STANDARD TEPPICHE LANGHAARIG</p>	<p>E-STANDARD CARPET LOW PILE NL-STANDAARD TAPIJT LAGE POOL FR-TAPIS STANDARD POIL BAS D-STANDARD TEPPICHE MIT KURZEM HAAR</p>
<p style="text-align: center;">25560H</p> 	<p style="text-align: center;">30560GR</p> 	<p style="text-align: center;">25560EE</p> 
<p>E-HEAVY CARPET NL-DIK TAPIJT FR-TAPIS EPAIS D-DICKE TEPPICHE</p>	<p>E-STANDARD CARPET + RIBBON NL-STANDAARD TAPIJT MET LINT FR-TAPIS STANDARD +RUBAN D-STANDARD TEPPICHE MIT BAND</p>	<p>E-LIGHT CARPET -NARROW OVERED NL-DUN TAPIJT SMALLE BOORD FR-TAPIS FIN SURJET ETROIT D-DÜNNE TEPPICHE MIT ENGEN KETTENSTICH</p>
<p style="text-align: center;">25117GR</p>  <p>DK2510</p>	<p style="text-align: center;">25560C</p> 	<p style="text-align: center;">25560K</p> 
<p>E-HEAVY CARPET +RIBBON NL-DIKKE TAPIJT + LINT FR-TAPIS SUPEREPAIS +RUBAN D-SEHR STARKE TEPPICHE MIT BAND</p>	<p>E-BLANKETS NL-DEKENS FR-COUVERTURES D-DECKEN</p>	<p>E-BUTTSEAMING NL-KOP AAN KOP NAAIEN FR-COUTURE BOUT A BOUT D-NÄHEN VON BEIDEN ENDEN</p>

PARTS BOOK

**WHEN ORDERING SPARE PARTS
FOR LEFTHAND OVEREDGING
MACHINE H-2500L
PLEASE MENTION "L"
AFTER THE REFERENCE NUMBER**

H-2500 PRESSURE FOOT MECHANISM (H-2502)

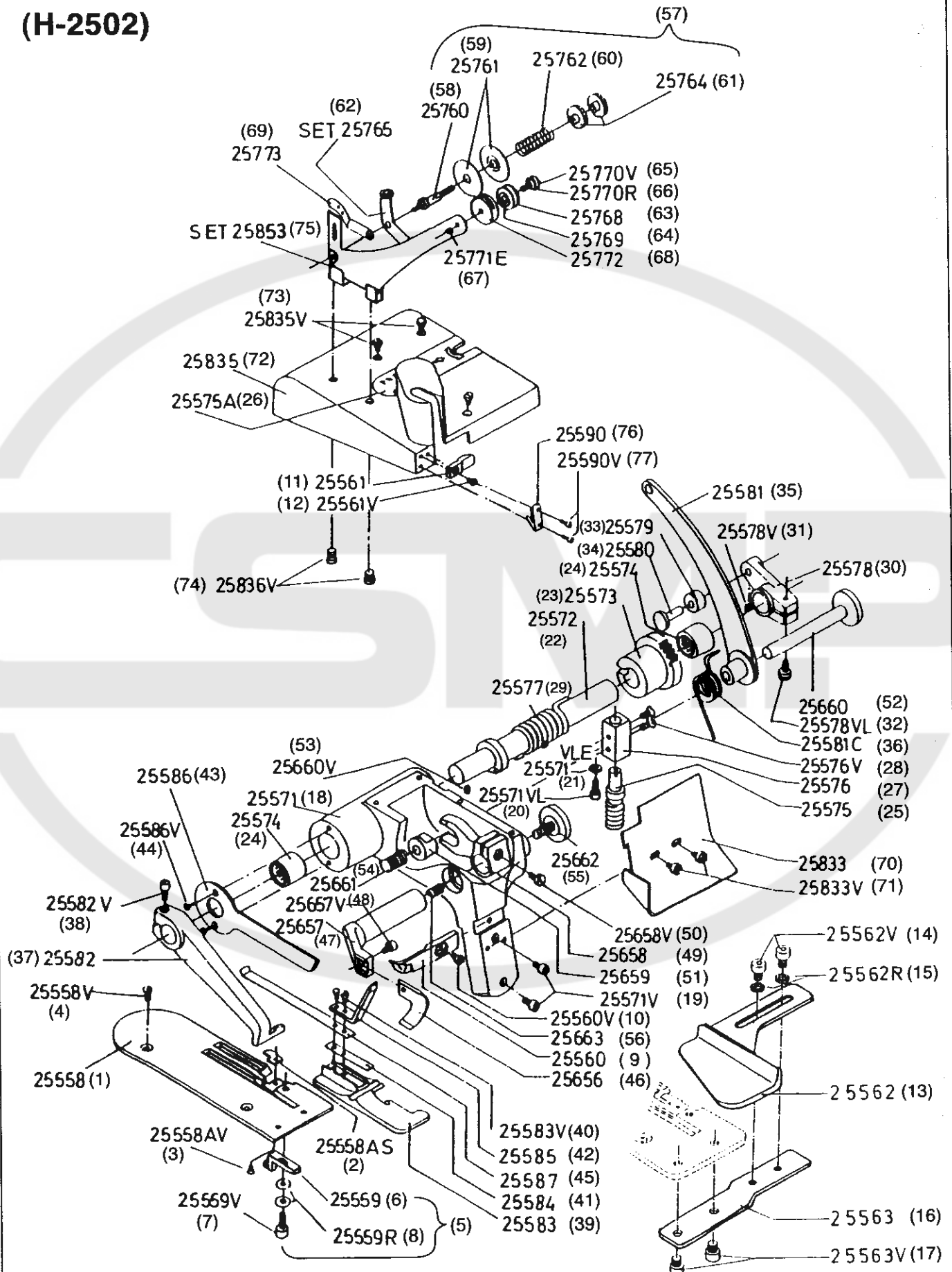

PRESSURE FOOT MECHANISM

1	25558	Needle plate	53	25660V	Screw
2	25558AS	Finger	54	25661	Feed spring
3	25558AV	Screw	55	25662	Screw
4	25558V	Screw	56	25663	Spring
5	<u>SET 25559A</u>	Needle guide complete	57	<u>SET 25760/1</u>	Tension complete
6	25559	Needle guide	58	25760	Tension post
7	25559V	Screw	59	25761	Tension disc
8	25559R	Washer	60	25762	Tension spring (1.2mm)
9	25560	Chain guide	61	25764	Nut
10	25560V	Screw	62	<u>SET 25765</u>	<u>Thread guide</u>
11	25561	Tension releaser	63	25768	Roller
12	25561V	Screw	64	25769	Bearing
13	25562	Guide	65	25770V	screw
14	25562V	Screw	66	25770R	Washer
15	25562R	Washer	67	25771E	Nut
16	25563	Guide holder	68	25772	Roller holder
17	25563V	Screw	69	25773	Thread guide
18	25571	Frame	70	25833	Protective plate
19	25571V	Screw	71	25833V	Screw
20	25571VL	Screw	72	25835	Cover
21	25571VLE	Nut	73	25835V	Screw
22	25572	Lever shaft	74	25836V	Screw
23	25573	Bushing	75	<u>SET 25853</u>	Tension holder
24	25574	Bearing	76	25590	
25	25575	Regulating screw	77	25590 V	
26	25575A	Label			
27	25576	Regulating screw holder			
28	25576V	Screw			
29	25577	Foot lifter spring			
30	25578	Rise lever			
31	25578V	Screw			
32	25578VL	Screw			
33	25579	Roller			
34	25580	Roller stud			
35	25581	Presser foot lever			
36	25581C	Return spring			
37	25582	Lever			
38	25582V	Screw			
39	25583	Pressure foot			
40	25583V	Screw			
41	25584	Spring			
42	25585	Holder for parallelism			
43	25586	Connecting rod			
44	25586V	Screw			
45	25587	Folium			
46	25656	Upper knife			
47	25657	Upper knife holder			
48	25657V	Screw			
49	25658	Position lever			
50	25658V	Screw			
51	25659	Slide block			
52	25660	Shaft			

H-2500 NEEDLE BAR MECHANISM (H-2502)

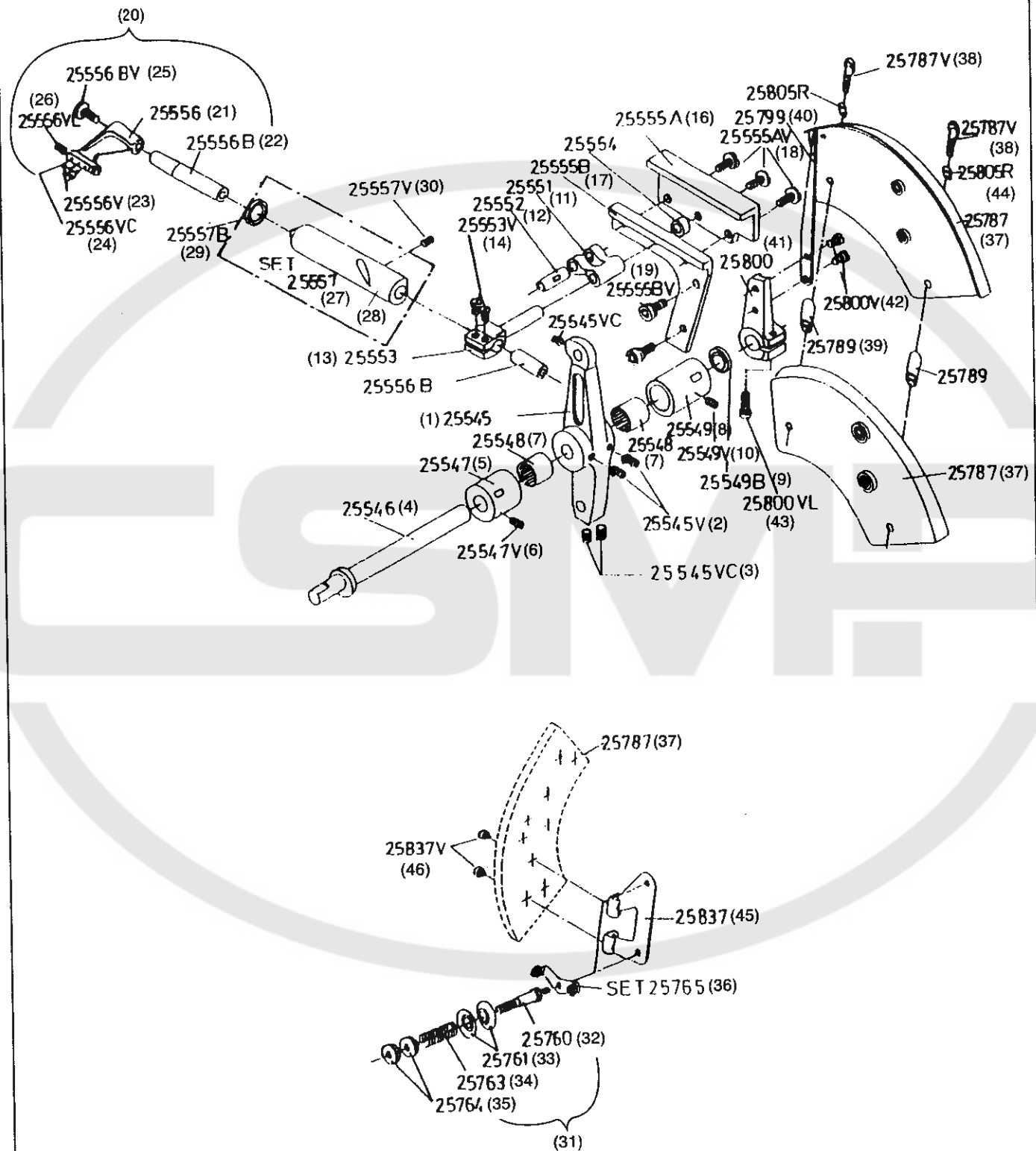

NEEDLE BAR MECHANISM

1	25545	Needle bar lever
2	25545V	Screw
3	25545VC	Screw
4	25546	Eccentric shaft
5	25547	Bushing
6	25547V	Screw
7	25548	Bearing
8	25549	Bushing
9	25549B	Seal
10	25549V	Screw
11	25551	Connection link
12	25552	Link shaft
13	25553	Connection stud
14	25553V	Screw
15	25554	Guide roller
16	25555A	Needle bar guide A
17	25555B	Needle bar guide B
18	25555AV	Screw
19	25555BV	Screw
20	<u>Set 25556</u>	Needle clamp assembly
21	25556	Needle clamp
22	25556B	Needle bar
23	25556V	Screw
24	25556VC	Screw
25	25556BV	Screw
26	25556VC	Screw
27	<u>SET 25557</u>	<u>Needle bar bushing</u>
28	25557	* Needle bar bushing
29	25557B	Seal
30	25557V	Screw
31	<u>SET 25760</u>	<u>Tension complete</u>
32	25760	Tension post
33	25761	Tension disc
34	25763	Tension spring (0.6 mm)
35	25764	Nut
36	<u>SET 25765</u>	<u>Thread guide plate</u>
37	25787	Thread guide holder
38	25787V	Screw
39	25789	Bushing
40	25799	Thread take-up
41	25800	Thread take-up lever
42	25800V	Screw
43	25800VL	Screw
44	25805R	Washer
45	25837	Tension holder
46	25837V	Screw

When ordering parts marked with a * the whole set will be delivered

FEEDDOG MECHANISM

1	<u>SET 25641</u>	Lower knife driving link complete
2	25640	Bearing
3	25641	* Lower knife driving link
4	25641V	Screw
5	25642	Driving link
6	25643	Lower shaft
7	25645	Stud
8	25699	Pin
9	25721	Feed across regulator
10	25722	Washer
11	25722E	Nut
12	25724	Bearing bushing
13	25725	Bearing
14	25726	Feed driving rod
15	25728	Feed driving lever
16	25728V	Screw
17	25728VL	Screw
18	25730	Bushing
19	25730V	Screw
20	25731	Bearing
21	25734	Thrust collar
22	25734V	Screw
23	25735	Lever
24	25735V	Screw
25	25736	Stud
26	25737	Base
27	25737P	Protection
28	25737V	Screw
29	25739	Feeddogg shaft
30	<u>SET 25743</u>	Complete feeddogg shaft guide
31	25742J	O-ring
32	25743	* Feeddogg shaft guide
33	25743V	Screw
34	25744	Feeddogg
35	25744V	Screw
36	25845	Plug
37	26010	Shaft
38	26011	Bushing
39	26012	Bearing
40	26014	O-ring

When ordering parts marked with a * the whole set will be delivered.

H-2500 (H-2502) LOWER LOOPER MECHANISM

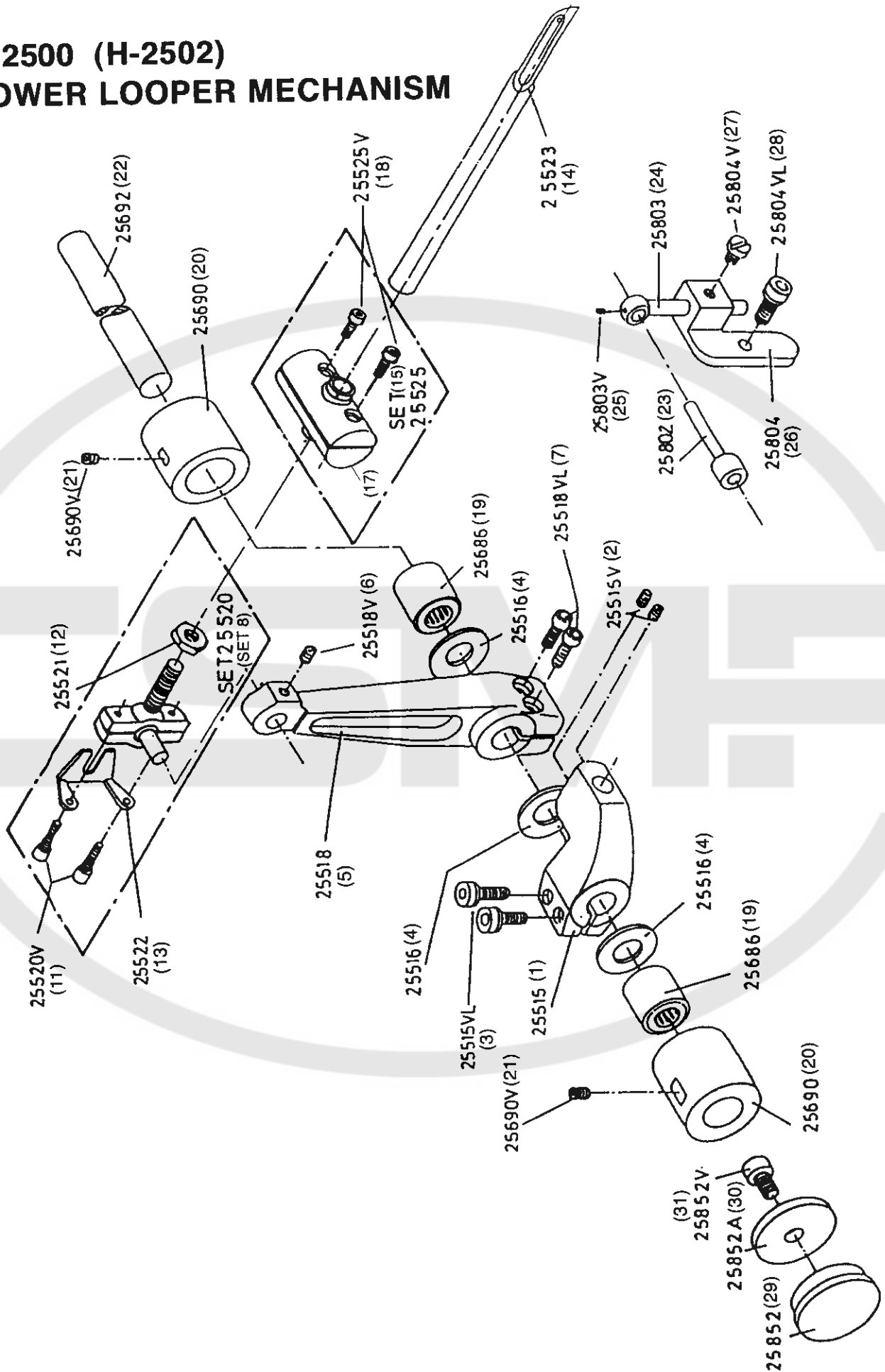

LOWER LOOPER MECHANISM

1	25515	Small lever
2	25515V	Screw
3	25515VL	Screw
4	25516	Washer
5	25518	Driving lever
6	25518V	Screw
7	25518VL	Screw
8	<u>SET 25520</u>	Complete ball joint
9	25519	* Looper ball
10	25520	* Ball joint
11	25520V	Screw
12	25521	Nut
13	25522	Ball joint guide fork
14	25523	Lower looper
15	<u>SET 25525</u>	Under looper guide complete
16	25524	* Ball
17	25525	* Under looper ball joint
18	25525V	Screw
19	25686	Needle bearing
20	25690	Bushing
21	25690V	Screw
22	25692	Shaft
23	25802	Thread guide
24	25803	Thread guide supporting shaft
25	25803V	Screw
26	25804	Thread guide holder
27	25804V	Screw
28	25804VL	Screw
29	25852	Plug
30	25852A	Washer
31	25852V	Screw

When ordering parts marked with a * the whole SET will be delivered.

H-2500 (H-2502) UPPER LOOPER MECHANISM

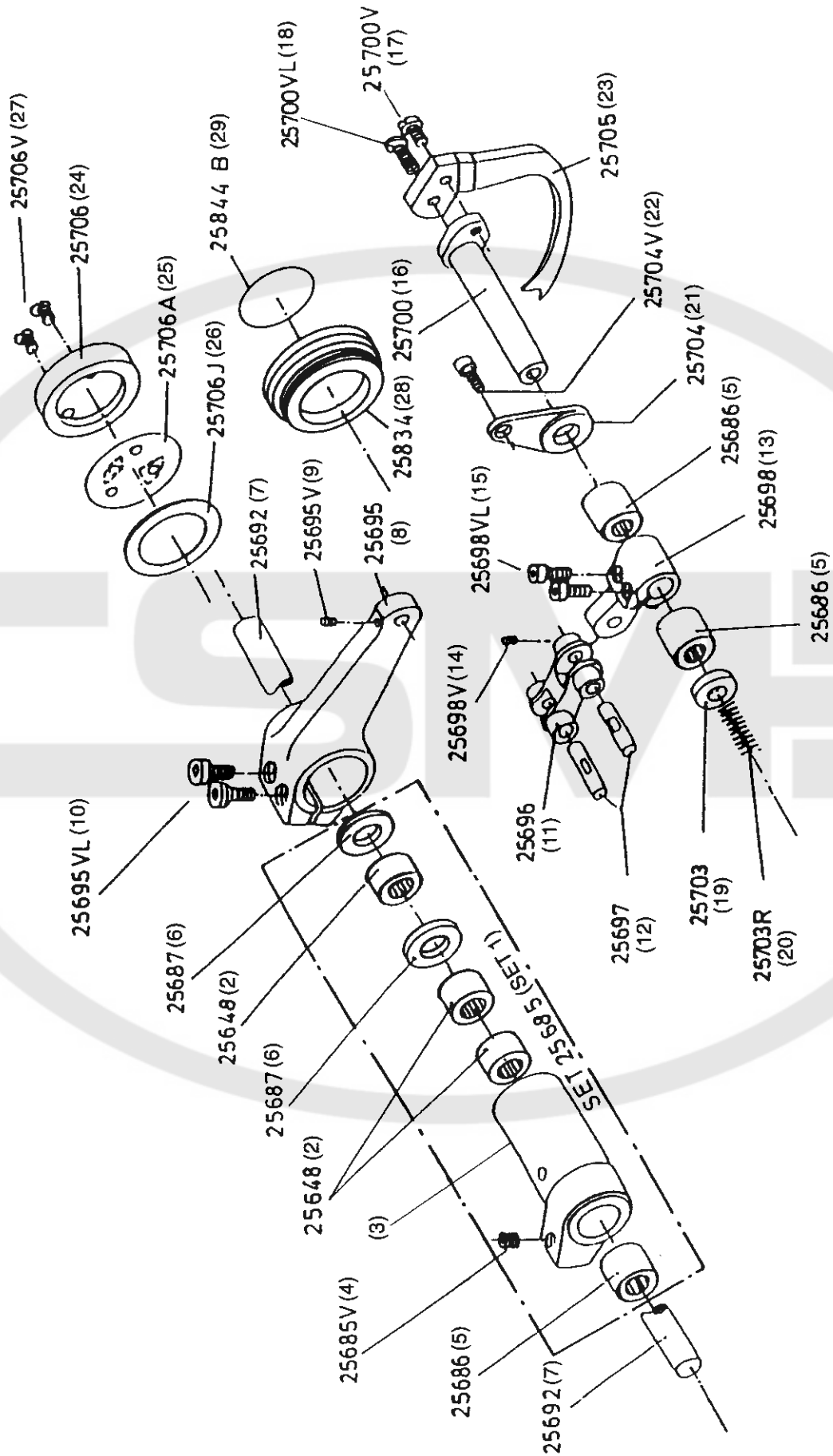

UPPER LOOPER MECHANISM

1	<u>SET 25685</u>	Complete intermediary assembly
2	25648	Bearing
3	25685	* Intermediate lever
4	25685V	Screw
5	25686	Bearing
6	25687	Washer
7	25692	Shaft
8	25695	Big lever
9	25695V	Screw
10	25695VL	Screw
11	25696	Connection link
12	25697	Link pin
13	25698	Small lever
14	25698V	Screw
15	25698VL	Screw
16	25700	Upper looper shaft
17	25700V	Screw
18	25700VL	Screw
19	25703	Washer
20	25703R	Spring
21	25704	Thrust plate
22	25704V	Screw
23	25705	Upper looper
24	25706	Oil window
25	25706A	Sticker
26	25706J	Packing
27	25706V	Screw
28	25834	Plug
29	25844B	Sticker

When ordering parts marked with a * the whole SET will be delivered.

H-2500 (H-2502) CUTTING DEVICE MECHANISM

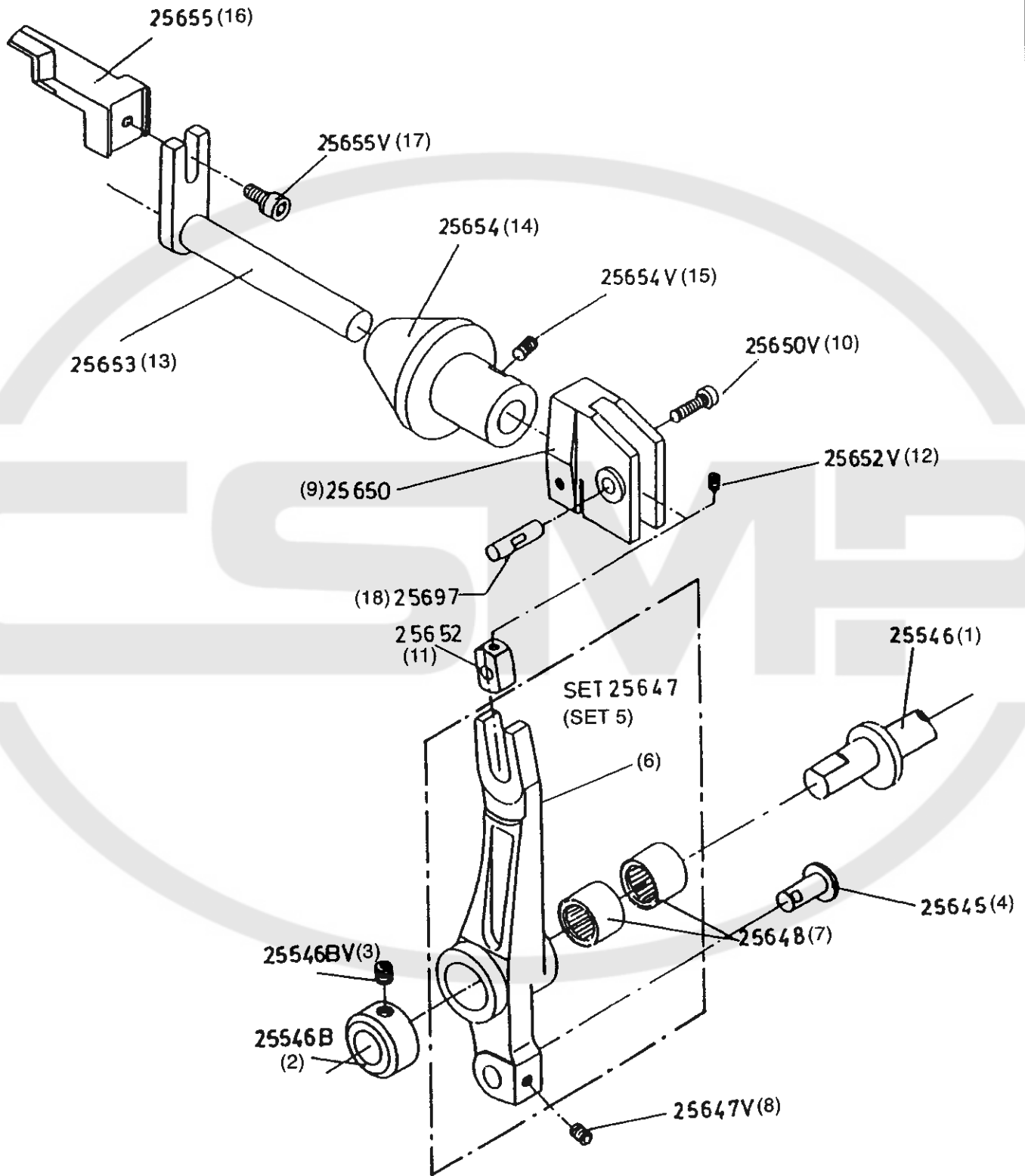

CUTTING DEVICE MECHANISM

1	25546	Eccentric shaft
2	25546B	Collar
3	25546BV	Screw
4	25645	Stud
5	<u>SET 25647</u>	Lower knife lever complete
6	25647	* Lower knife lever
7	25648	Bearing
8	25647V	Screw
9	25650	Slide block guide
10	25650V	Screw
11	25652	Slide block
12	25652V	Screw
13	25653	Lower knife shaft
14	25654	Lower knife bushing
15	25654V	Screw
16	25655	Lower knife
17	25655V	Screw
18	25697	Link pin
	25656	Upper knife (see PRESSURE FOOT MECHANISM)

When ordering parts marked by a * the whole SET will be delivered.

H-2500 (H-2502) CRANK SHAFT

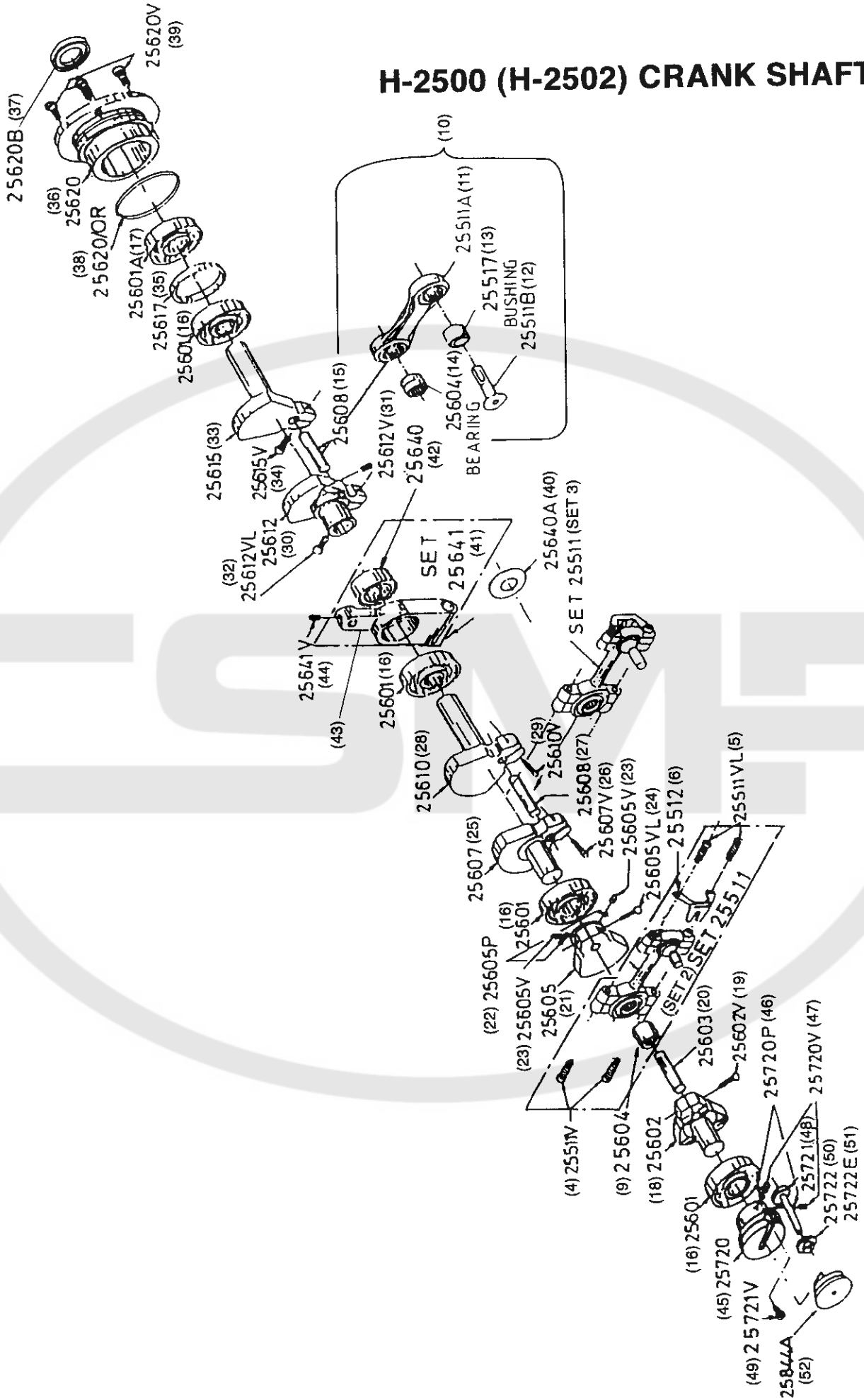

CRANK SHAFT

1	25114	Plug	51	25722E	Nut
			52	25844A	Plug
2	<u>SET 25511</u>	Connecting rod complete			
3	25511	* Connecting rod			
4	25511V	Clamp screw			
5	25511VL	Clamp screw			
6	25512	Ball joint guide fork			
7	25513	* Ball			
8	25514	* Ball			
9	25604	Bearing			
10	<u>SET 25511A</u>	Complete rod			
11	25511A	Rod			
12	25511B	Stud			
13	25517	Bushing			
14	25604	Bearing			
15	25608	Pin			
16	25601	Bearing			
17	25601A	Bearing			
18	25602	Crank			
19	25602V	Screw			
20	25603	Pin			
21	25605	Crank			
22	25605P	Protection			
23	25605V	Screw			
24	25605VL	Screw			
25	25607	Crank			
26	25607V	Screw			
27	25608	Pin			
28	25610	Crank			
29	25610V	Screw			
30	25612	Crank			
31	25612V	Screw			
32	25612VL	Screw			
33	25615	Crank			
34	25615V	Screw			
35	25617	Ring			
36	25620	Bearing bushing			
37	25620B	Seal			
38	25620/OR	O-Ring			
39	25620V	Screw			
40	25640A	Washer			
41	<u>SET 25641</u>	Lower knife driving link			
42	25640	Bearing			
43	25641	* Lower knife driving link			
44	25641V	Screw			
45	25720	Eccentric			
46	25720P	Protection			
47	25720V	Screw			
48	25721	Feed across regulator			
49	25721V	Screw			
50	25722	Washer			

When ordering parts marked with a *
the whole set will be delivered.

H-2600cv PULLER FOR MACHINE H-2500 (H-2502)

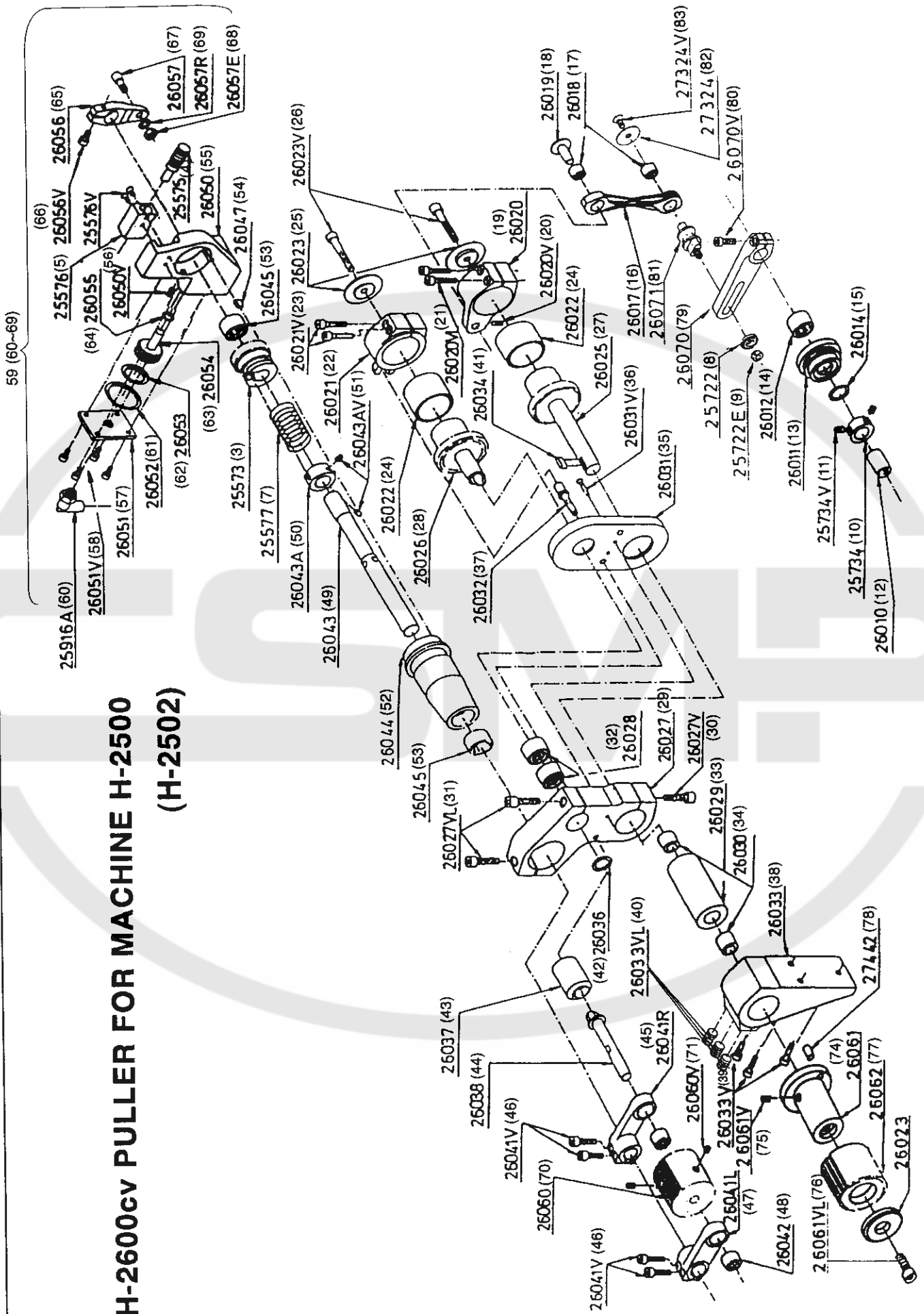

PULLER H-2600cv (option)

1	25133	Lever	50	26043A	Thrust collar
2	25133V	Screw	51	26043AV	Screw
3	25573	Bushing	52	26044	Bushing
4	25575	Regulating screw	53	26045	Bearing
5	25576 (25576L)	Screw holder	54	26047	Block
6	25576V	Screw	55	26050 (26050L)	Piston frame
7	25577 (25577L)	Foot lift spring	56	26050V	Screw
8	25722	Washer	57	26051	Cover
9	25722E	Nut	58	26051V	Screw
10	25734	Thrust collar			
11	25734V	Screw	59	<u>SET 26054</u>	<u>Pneumatic cylin.</u>
12	26010	Big shaft	60	25916A	Elbow
13	26011	Bushing	61	26052	O-ring
14	26012	Bearing	62	26053	O-ring
15	26014	Seal-ring	63	26054	Piston
16	26017	Lever	64	26055	O-ring
17	26018	Bushing	65	26056	Lever
18	26019	Pin	66	26056V	Screw
19	26020	Lever	67	26057	Pin
20	26020V	Screw	68	26057E	Nut
21	26020VL	Screw	69	26057R	Washer
22	26021	Lever			
23	26021V	Screw	70	26060	Upper wheel
24	26022	Wheel	71	26060V	Screw
25	26023	Washer			
26	26023V	Screw	72	<u>SET 26062</u>	Lower wheel
27	26025	Lower shaft	73	26023	Washer
28	26026	Upper shaft	74	26061	Bushing
29	26027	Frame	75	26061V	Screw
30	26027V	Screw	76	26061VL	Screw
31	26027VL	Screw	77	26062	Feed-roll
32	26028	Bearing	78	27442	Pin
33	26029	Bushing			
34	26030	Bearing	79	26070	Lever
35	26031	Gear cover	80	26070V	Screw
36	26031V	Screw	81	26071	Stud
37	26032	Pin	82	27324	Washer
38	26033	Fixation support	83	27324V	Screw
39	26033V	Screw			
40	26033VL	Screw			
41	26034	Block			
42	26036	Snap ring			
43	26037	Bushing			
44	26038	Cardan			
45	26041R	Lever			
46	26041V	Screw			
47	26041L	Lever			
48	26042	Bearing			
49	26043	Lever shaft			

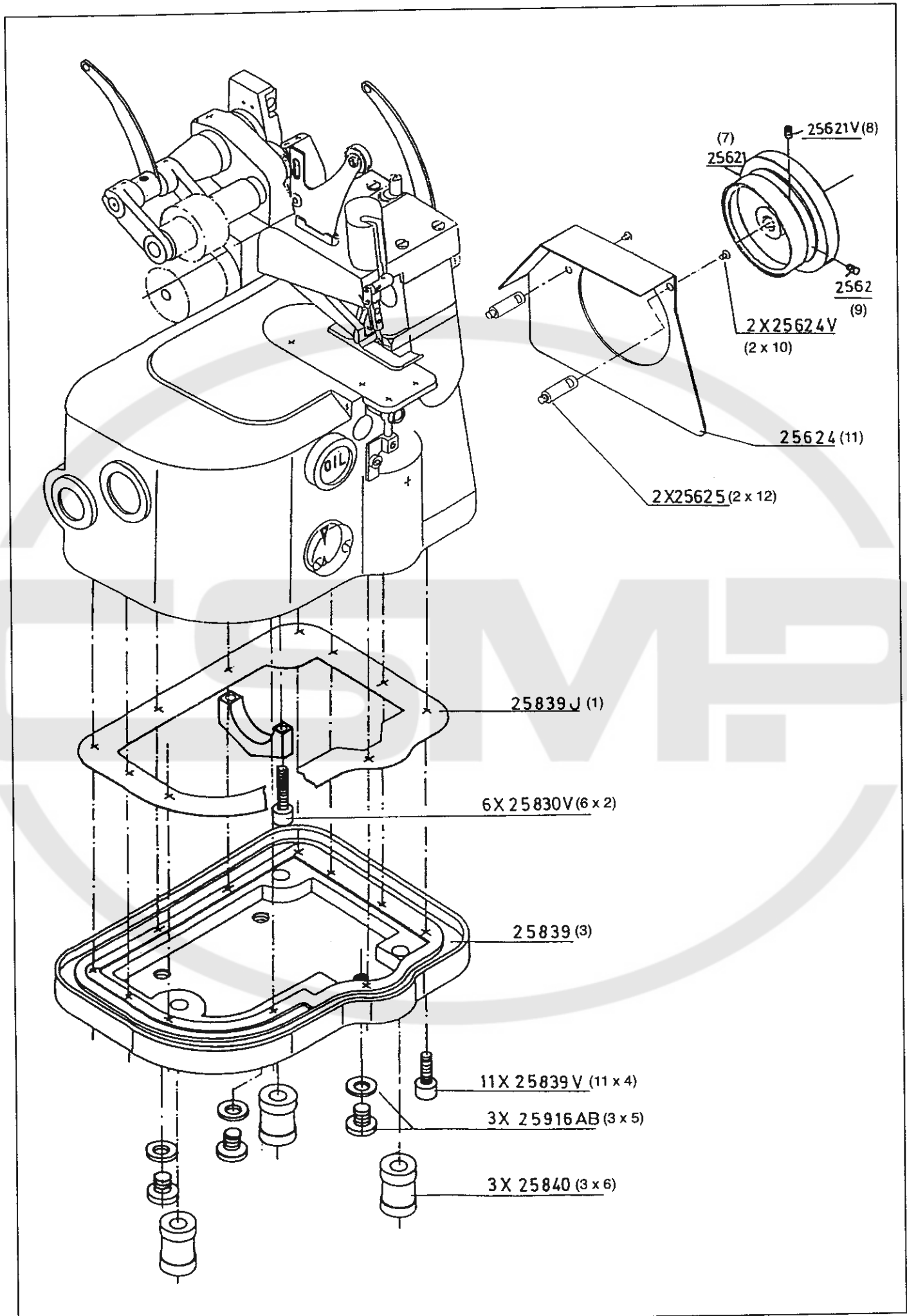

**FITTING A PULLER H-2600
ON MACHINE H-2500 OR H-2500L**

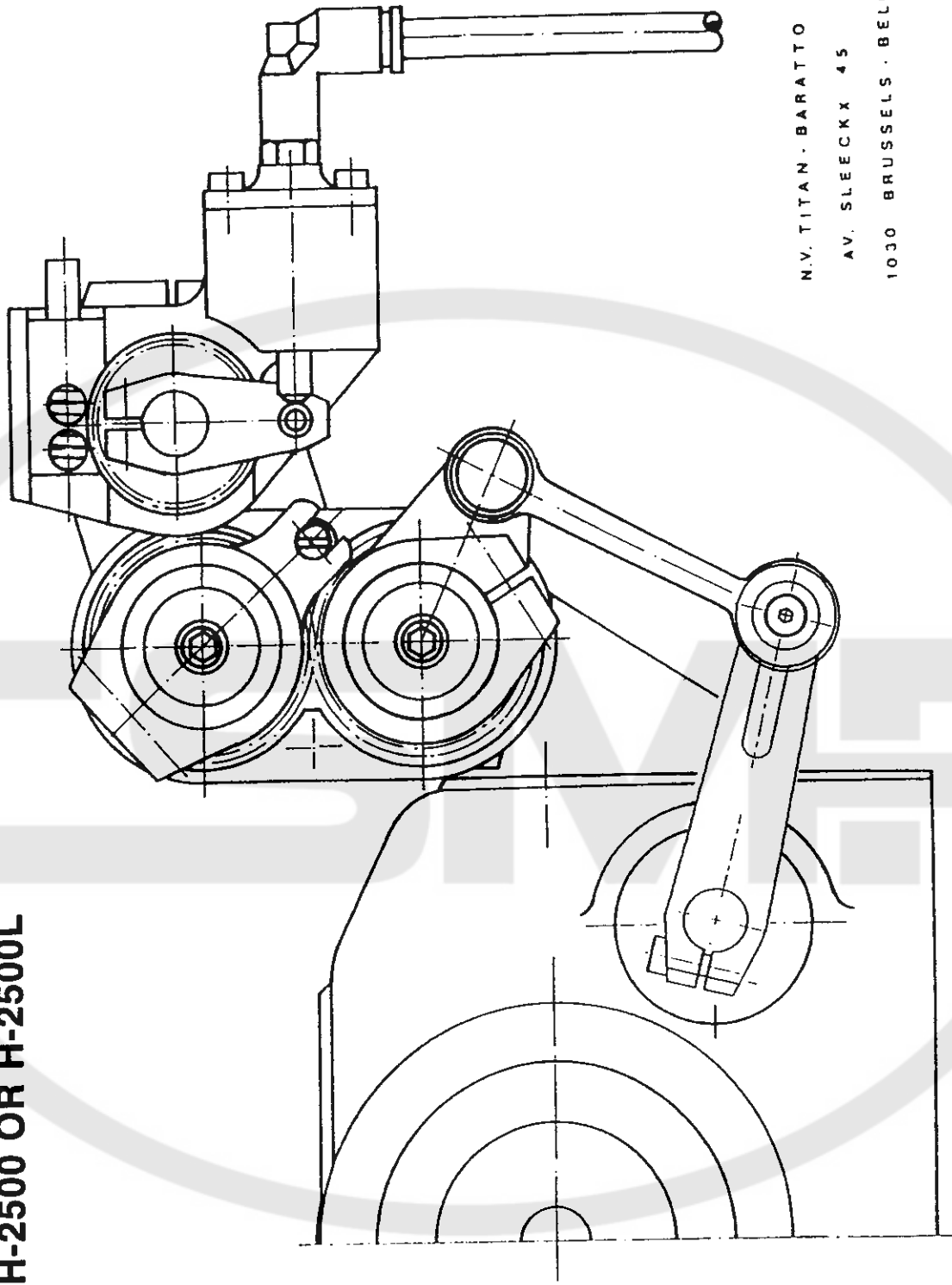

N.V. TITAN - BARATTO S.A.
AV. SLEECKX 45
1030 BRUSSELS - BELGIUM

**FITTING A PULLER H-2600
ON MACHINE H-2500 OR H-2500L**

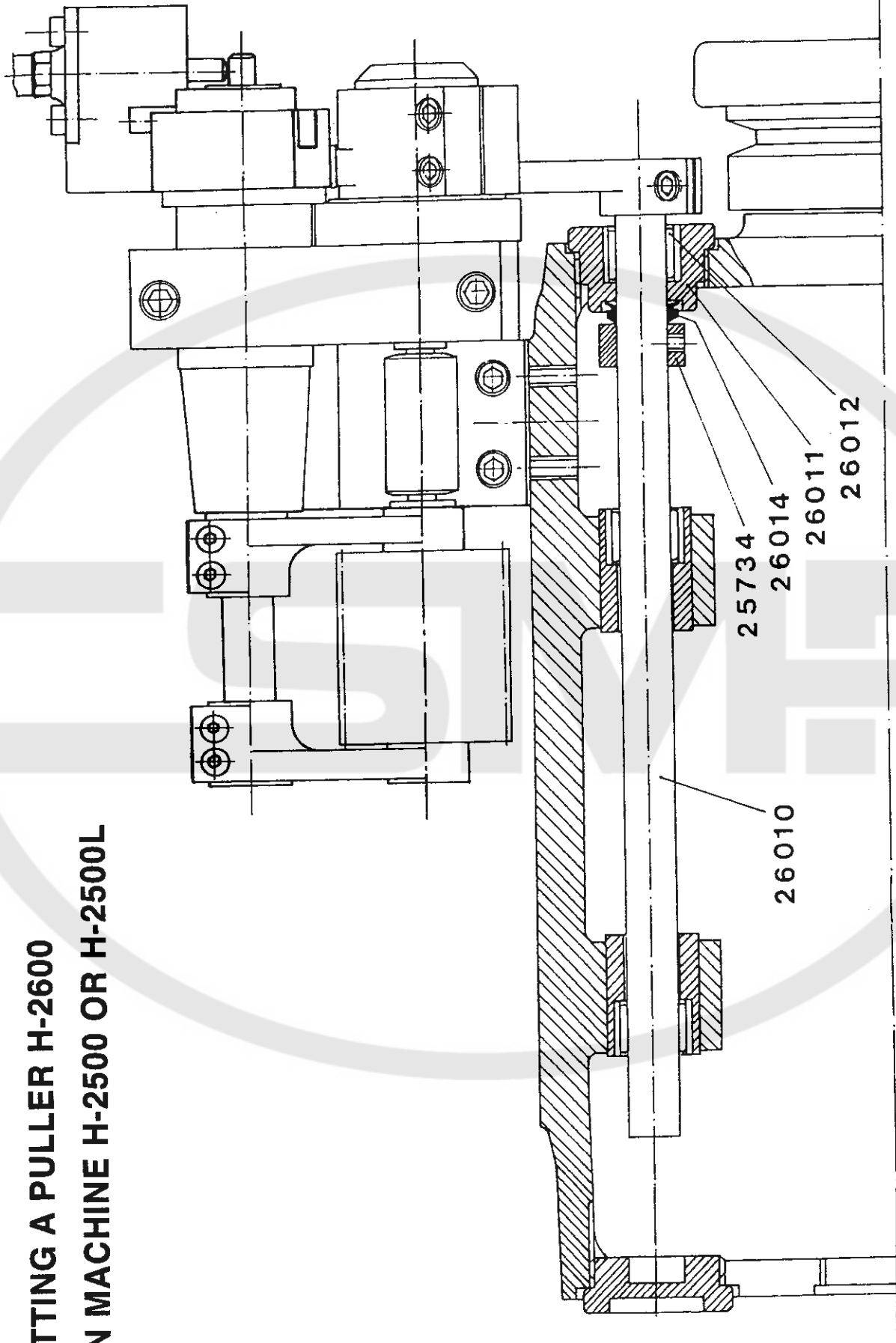

NV TITAN-BARATTO SA AV SLEECKX 45 · 1030 BRUSSELS · BELGIUM

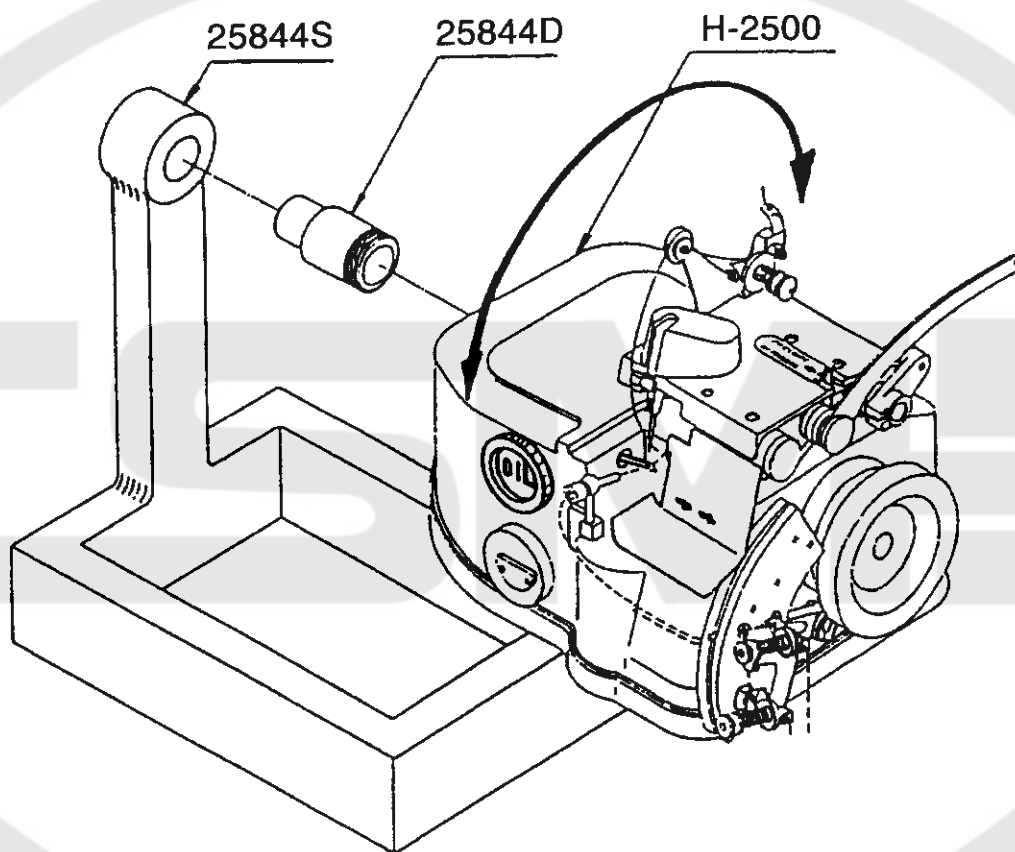

SERVICING WORKSTAND

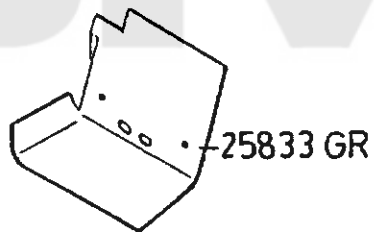
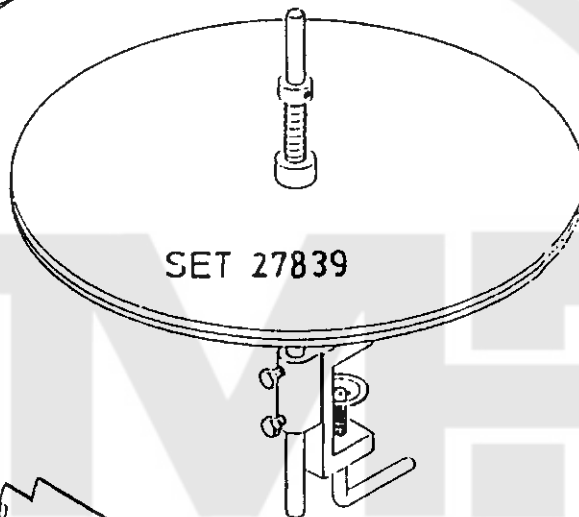
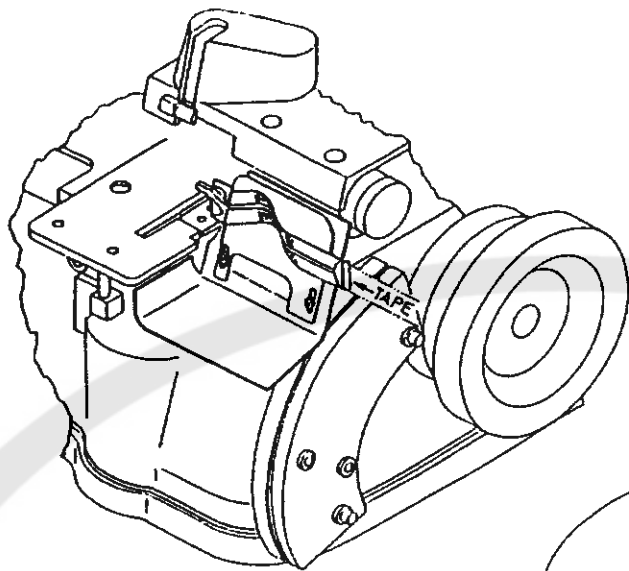

30566

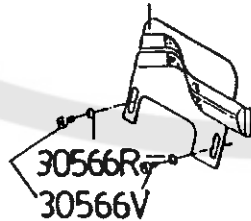

**TAPE INSERTION FOR H-2500 WITH OR
WITHOUT KNIVES**

LOWER LOOPER MECHANISM

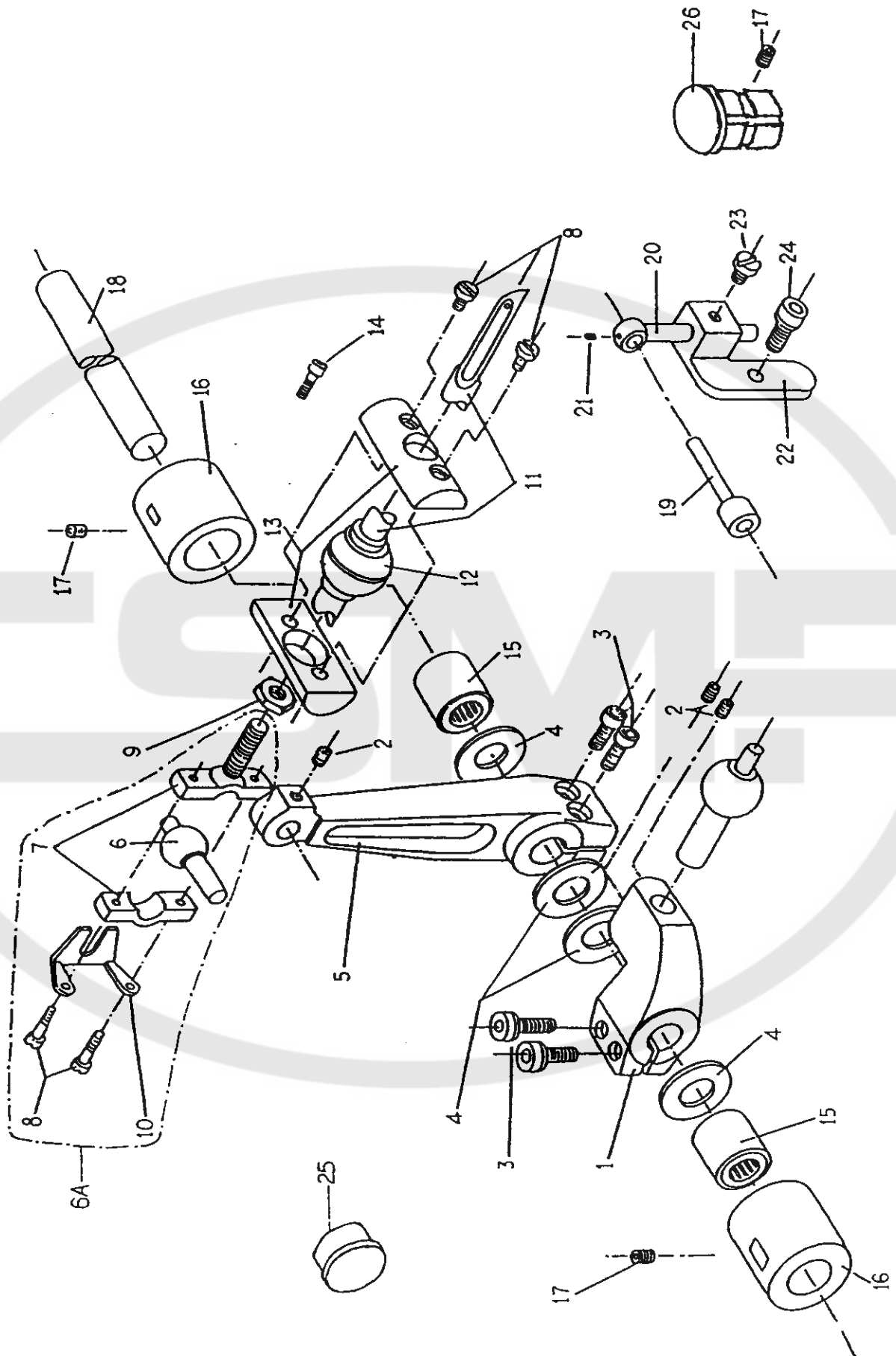

UPPER LOOPER MECHANISM

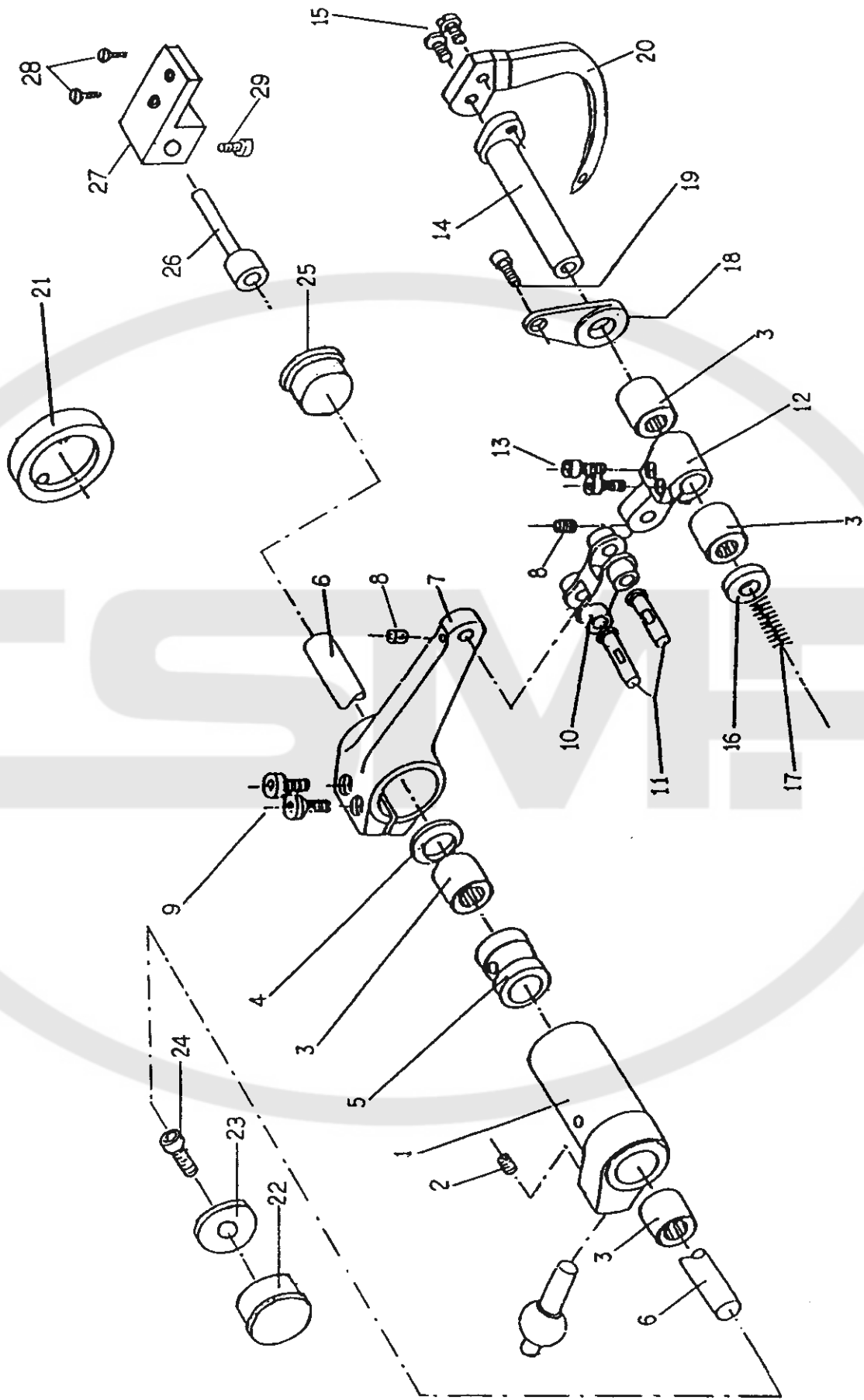

LOWER LOOPER MECHANISM

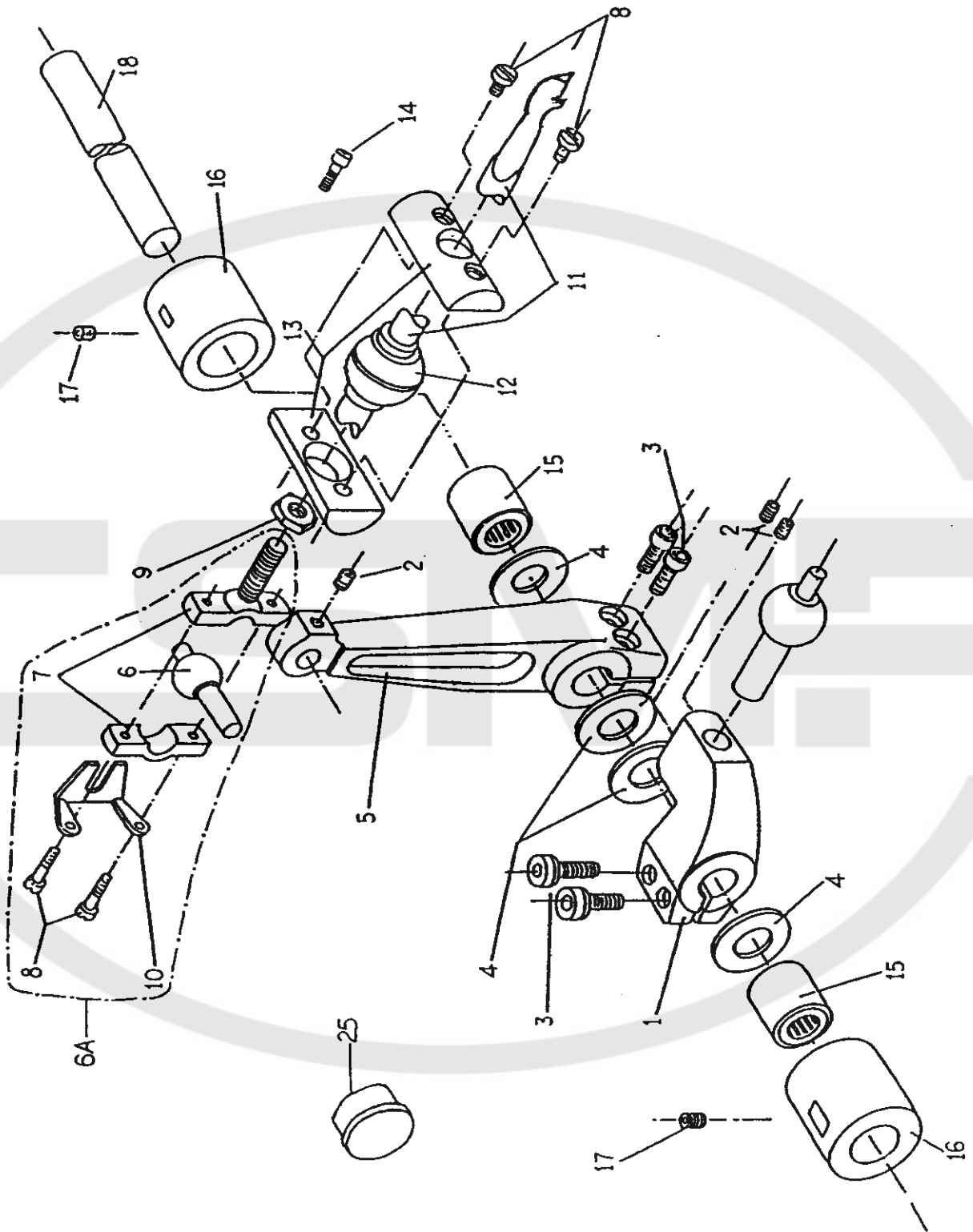

CUTTING DEVICE

