

Teileliste und Naeheinrichtungen
Spare Parts List and Sewing Equipment

767

DÜRKOPP ADLER AG

Postfach 17 03 51, D-33703 Bielefeld • Potsdamer Straße 190, D-33719 Bielefeld
Telefon +49 (0) 5 21/ 9 25-00 • Telefax +49 (0) 5 21/ 9 25 24 35 • www.duerkopp-adler.com

Ausgabe / Edition:
03/2007

Änderungsindex
Rev. index: **01.0**

Printed in Federal Republic of Germany

Teile-Nr./Part-No.:
0791 767801



Alle Rechte vorbehalten.

Eigentum der Dürkopp Adler AG und urheberrechtlich geschützt. Jede, auch auszugsweise Wiederverwendung dieser Inhalte ist ohne vorheriges schriftliches Einverständnis der Dürkopp Adler AG verboten.

All rights reserved.

Property of Dürkopp Adler AG and copyrighted. Reproduction or publication of the content in any manner, even in extracts, without prior written permission of Dürkopp Adler AG, is prohibited.

Copyright © Dürkopp Adler AG - 2007

Erläuterungen zur Ersatzteilleiste

1. Kennzeichnung der Ersatzteile

Zu einer Einheit gehörende Einzelteile sind durch eine strichpunktierte Linie eingerahmt. Die Einheit kann auch komplett unter der voll eingerahmten Nr. (in einem Kasten) bestellt werden. Zu dieser Einheit gehören keine Teile, deren Nr. ausserhalb der strichpunktierten Linie steht.

Teile, die mit "N" gekennzeichnet sind, werden nicht einzeln geliefert.

Sollten Sie ein Teil nicht in der Ersatzteilleiste auffinden, was durch technische Änderungen vorkommen kann, dann geben Sie uns bitte zur Teile- und Funktionsbeschreibung die genaue Unterklasse und Fabrik-Nr. lt. Typenschild bekannt.

Bei Bestellungen von Elektroteilen bitten wir die zusätzlichen Angaben, die in Klammern hinter der Teile-Nr. stehen, mit anzugeben.

Im Inhaltsverzeichnis sind die Teile-Nr. nach steigenden Nr. geordnet. Ausserdem sind angegeben :

Teile-Nr.	993 91 083 8	Zyl. Schr.	M 4 x 10	3 - B1
Benennung				
Abmessung				
Bildtafel Nr. (rechts und links oben in der Bildtafel eingekreiste Nr.)				
Planquadrat der jeweiligen Bildtafel				

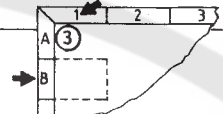

2. Verwendete Bildzeichen

- = siehe Mechanikeranleitung
- = ohne Fadenabschneider
- = Hinweis auf Unterscheidungsmerkmal
- = fluessig sichern, kleben, dichten
Loctite 270, Nr.990 49 034 6
- = mit Fadenabschneider
- mm = Maße
- = 1 Nadel
- = Laenge oder Flaechе angeben
- = links
- = rechts
- = veraltete Ausfuehrung
- a.W. = auf Wunsch
- = 2 Nadeln

3. Handhabung der Ersatzteilleiste

Taetigkeit :

Blaetter der Ersatzteilleiste:

Erklaerung :

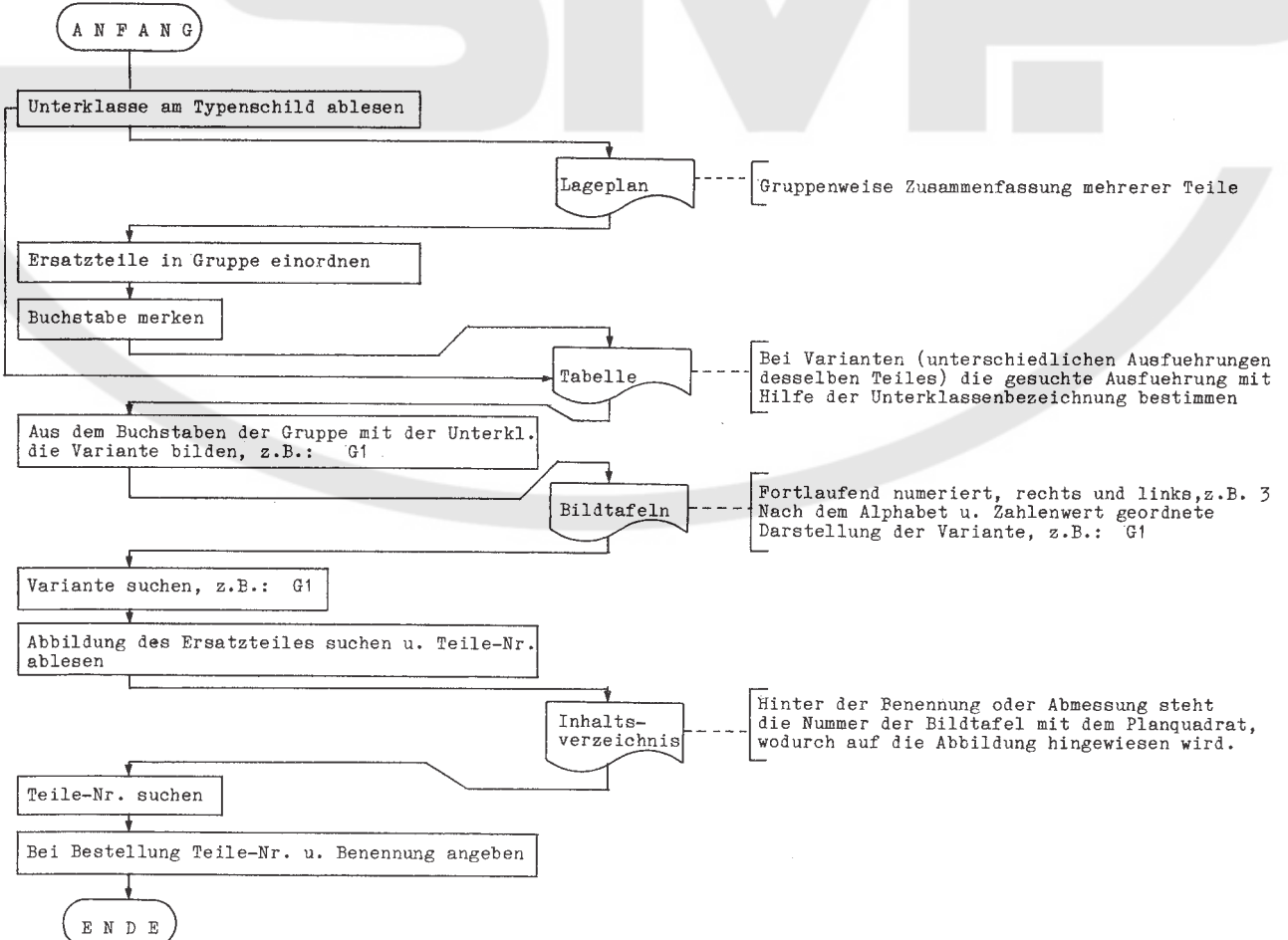

4. Jeder Nachdruck, auch auszugsweise, ist nur mit unserer Genehmigung gestattet. Änderungen behältent wir uns vor.

Explanation of spare parts list

1. Numbering of parts

The component parts of a complete unit are framed by a dot-dash line. The unit can also be ordered complete by quoting the number enclosed in the full lined "box" contained within the dot-dash frame. Any parts, the numbers of which are outside of the frame, are not part of the unit and must be ordered separately.

Parts marked with "N" cannot be supplied singly.

If a part cannot be found in the parts list, possibly due to technical alteration, when ordering, please describe the part and function fully, quoting the sub-class and serial number of the machine according to the specification plate.

When ordering electrical parts, please include the additional information set in brackets after the part number.

In the table of contents the part numbers are listet in numerical order, e.g.

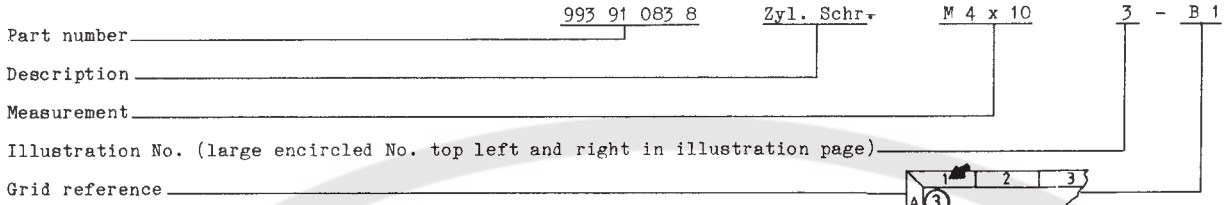

2. Symbols applied

= see mechanics manual

= without thread cutter

= point of alteration

= 1 needle

= secure by glueing, seal
Loctite 270, No. 990 49 034 6

= with thread cutter

mm = measurement

V = obsolete

= 2 needles

= declar length or area

= left

d.W. = on request

= right

3. Using the parts list

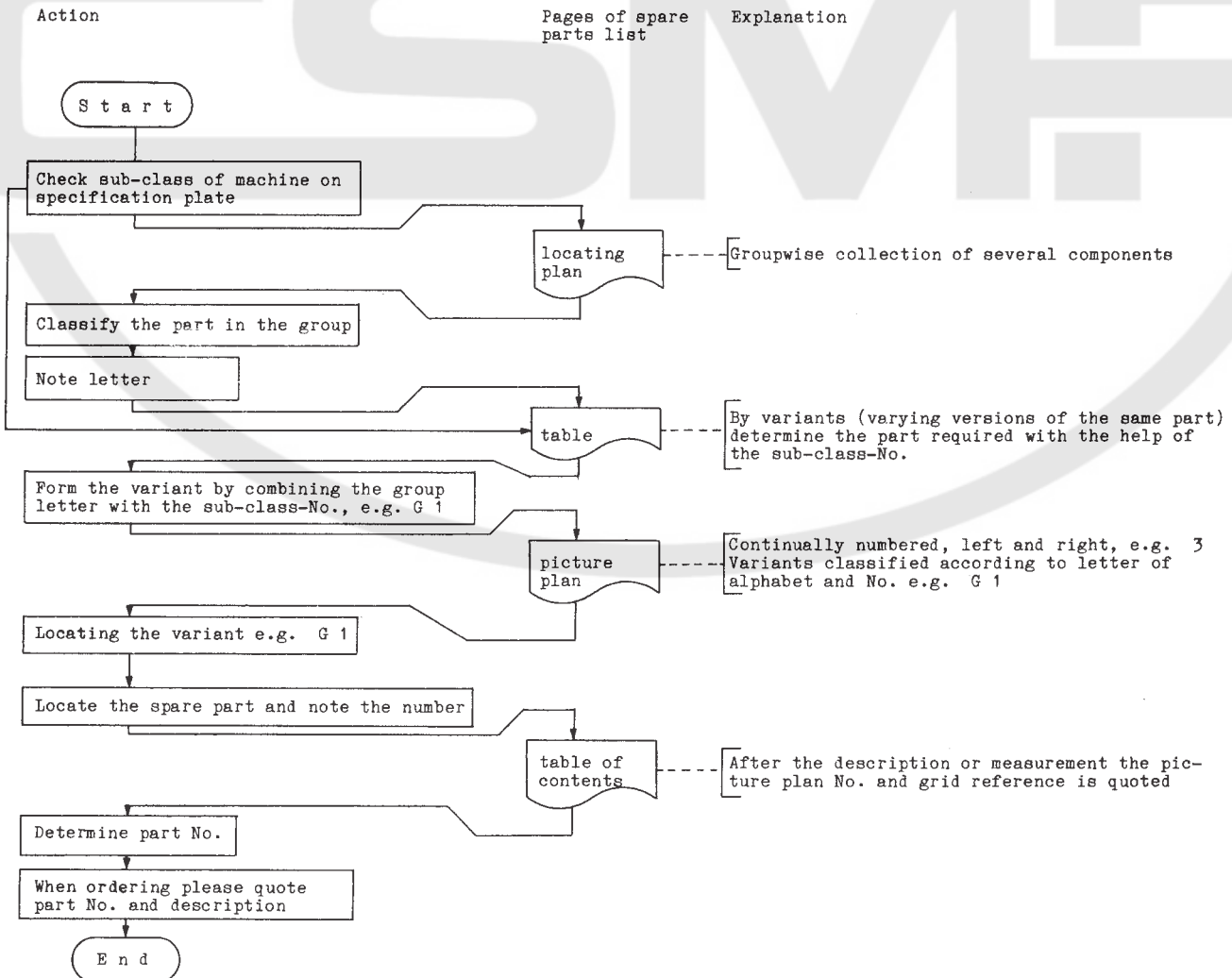

4. All reproductions, also in part, require our permission. Subject to alteration.

Explications pour la liste de pièces de rechange

1. Identification des pièces de rechange

Les pièces individuelles faisant partie d'une unité ont été encadrées d'une ligne à point-trait. L'unité peut être commandée aussi sous le numéro complètement encadré. Aucune pièce dont le numéro se trouve en dehors de l'encadrement n'appartient à cette unité.

Les pièces marquées par "N" ne sont pas livrables séparément.

Dans le cas où une pièce de rechange n'est pas indiquée dans la liste de pièces de rechange, ce qui peut se produire au cours de changements techniques, en cas de commande, veuillez indiquer la sous-class exacte ainsi que le numéro de fabrication de la machine selon le matricule.

Dans le cas de commande de pièces électriques veuillez également donner les indications supplémentaires qui se trouvent entre parenthèses après le numéro de la pièce.

Dans le table de matière les numéros des pièces sont indiqués par ordre numérique. En outre sont indiqués :

Numéro de la pièce _____ 993 91 083 8 Zyl. Schr. M 4 x 10 3 B 1
 Nom de la pièce _____
 Mesures _____
 Numéro de la planche (En haut, à droite et à gauche de chaque planche,
 le numéro indiqué dans un cercle) _____
 Carré de plan de chaque planche _____

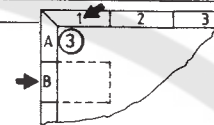

2. Symboles utilisés

	= voir instructions pour le mécanicien		= sans coupe-fil		= indication pour point de variation		= 1 aiguille
	= coller, fermer hermétiquement Loctite 270, No. 990 49 034 6		= avec coupe-fil	mm	= mesures		= 2 aiguilles
	= indiquer longueur ou surface		= gauche	V	= ancien model		
			= droite	a.W.	= sur demande		

3. Emploi correct de la liste de pièces de rechange

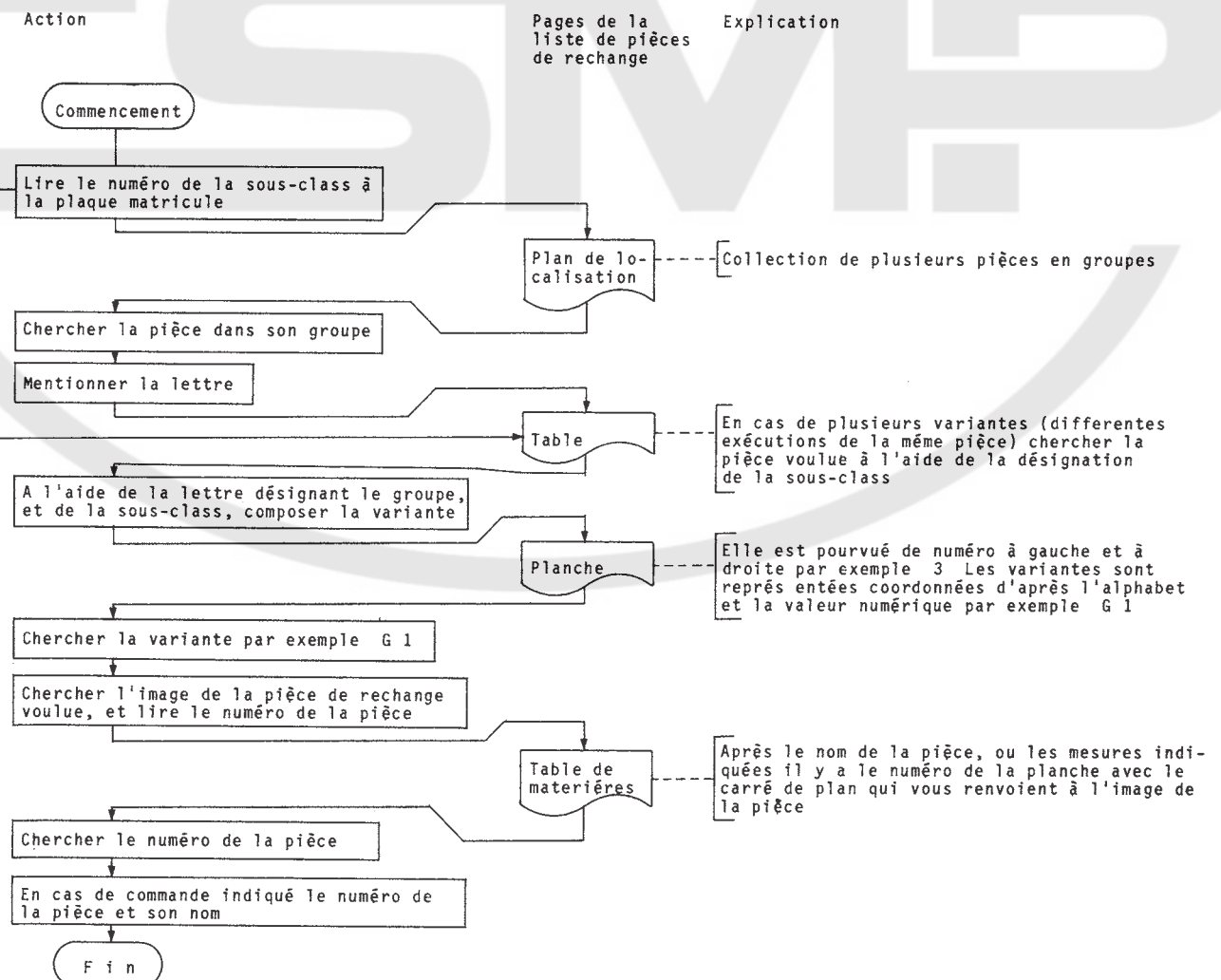

4. Toute reproduction, meme en partie, n'est autorisée qu'avec notre permis. Nous nous reservons le droit de change

Aclaraciones a la lista de piezas de repuesto

1. Marcado de las piezas de requesto

Las piezas sueltas pertenecientes a una unidad están encuadradas por una raya de puntos. La unidad también se puede pedir completa con el número encuadrado por completo (en un cajetín). A esta unidad no pertenece ninguna pieza cuyo número quede fuera de la raya punteada.

Las piezas señaladas con una "N" no se sirven solas.

Si no encuentra usted una pieza en la lista de piezas de requesto - cosa que puede ocurrir por haber variaciones técnicas -, indiquenos entonces, junto a la descripción de la pieza y su función, la subclase exacta y el número de fábrica que figura en la placa del tipo.

En los pedidos de piezas eléctricas rogamos que también se nos indiquen los datos adicionales que figuran entre paréntesis detrás del número de la pieza.

En el sumario figuran los números de las piezas en progresión ascendente. Además se indican:

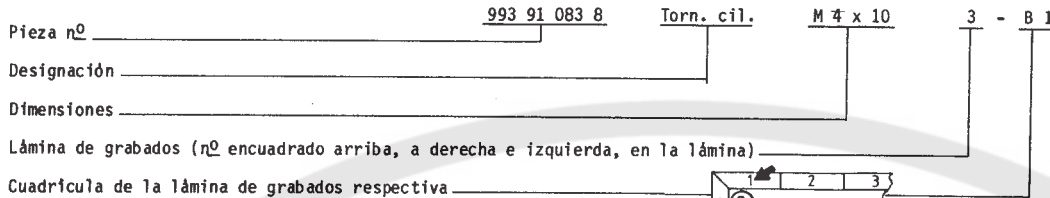

2. Símbolos empleados

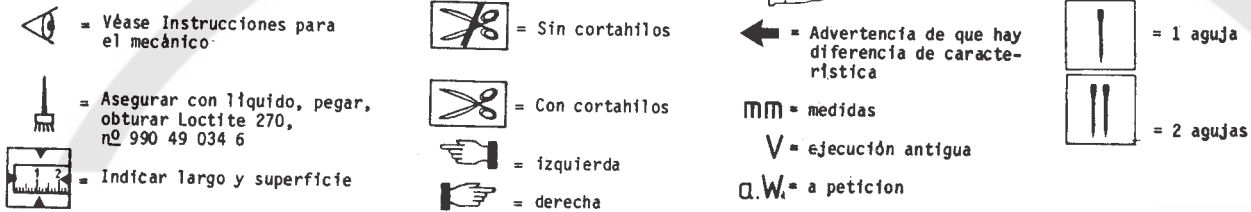

3. Forma de proceder con la lista de piezas de repuesto

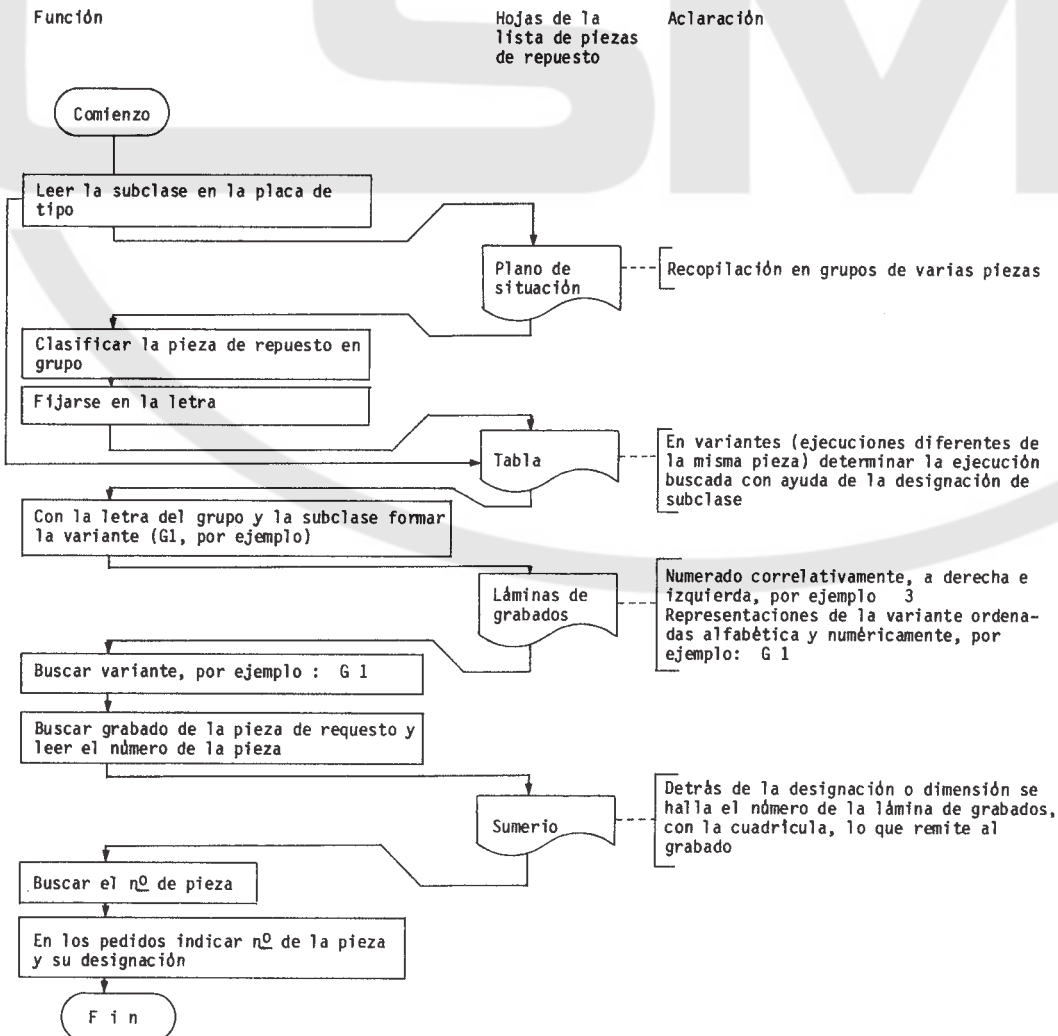

4. Toda reproducción, incluso extractada, sólo está permitida con nuestra autorización. Nos reservamos el derecho a hacer modificaciones.

1. Contrassegni dei pezzi di ricambio

Pezzi singoli componenti un gruppo sono racchiusi in una linea a punti e tratti. Il gruppo può essere anche ordinato completo indicando all'ordine il numero di pezzo incorniciato da una linea continua. I pezzi il cui numero è situato fuori della linea a punti e tratti non appartengono al gruppo

Pezzi contrassegnati con la lettera N non possono essere forniti come pezzo singolo

Nel caso che un pezzo non si trovi nel libretto parti di ricambio, ciò può succedere a causa delle continue innovazioni tecniche, indicate, accanto alla descrizione della funzione del pezzo e l'eventuale schizzo o descrizione minuta del pezzo, la classe e sottoclasse esatta ed il numero di fabbricazione riportati in targhetta

Ordinando componenti elettrici indicare i dati suppletivi segnati in parentesi dietro il numero del pezzo

Nell'indice i numeri dei pezzi sono ordinati secondo numero progressivo ed inoltre sono indicati:

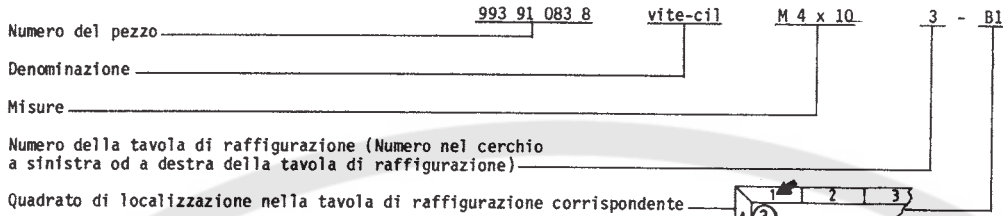

2. Simboli figurati utilizzati

	= Vedi libretto istruzioni per i meccanici		= Senza rasafilo		= Indicazione per notare le differenze tra i pezzi		= 1 ago
	= Fissaggio, incollaggio o tenuta del pezzo tramite liquido Loctite 270, Nr. 990 48 034 6		= Con rasafilo	mm	= Misura		= 2 aghi
	= Indicare la lunghezza o la superficie		= Sinistra (o)	V	= Esecuzione invecchiata		
			= Destra (o)	d.W.	= A richiesta		

3. Uso del libretto parti di ricambio

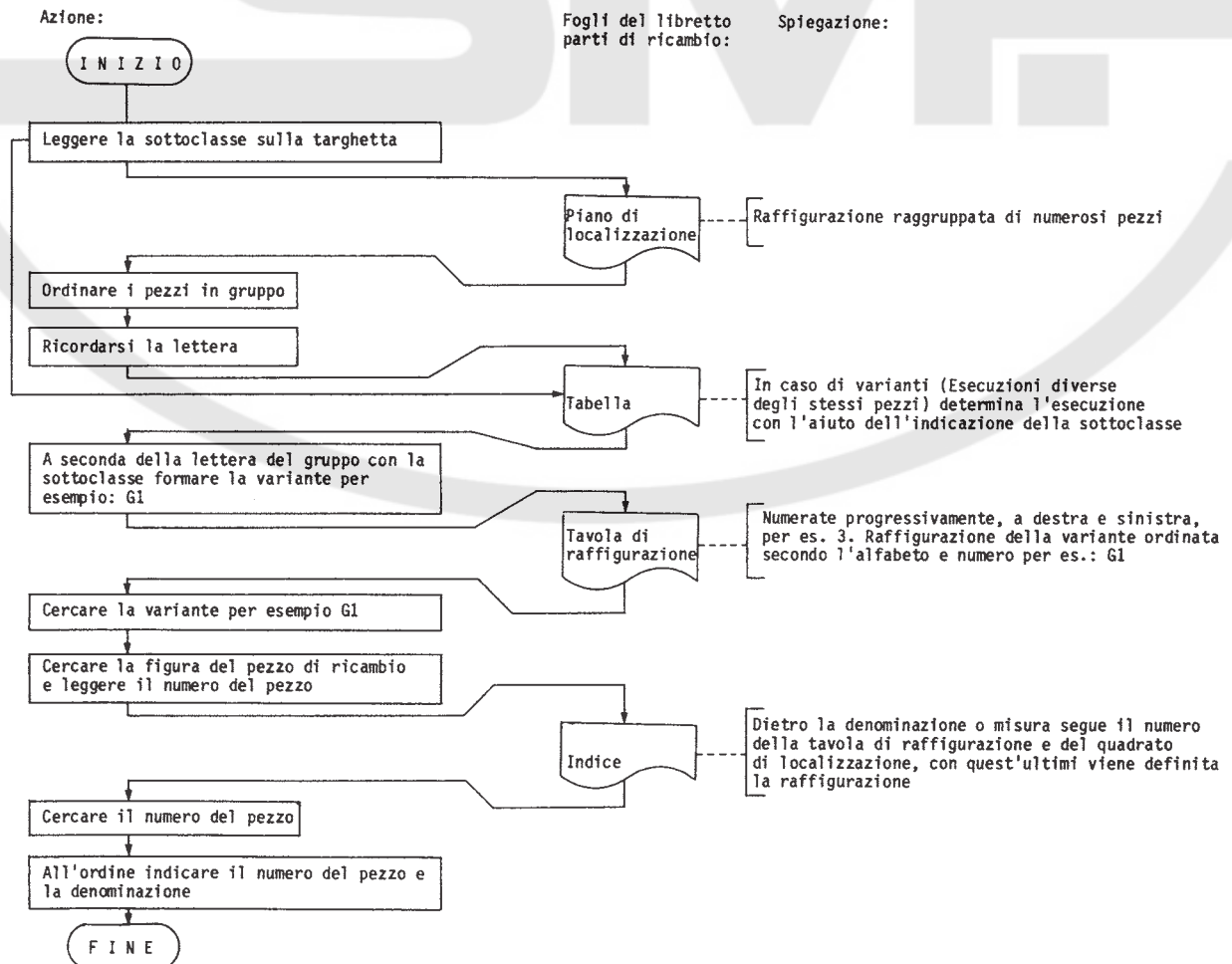

Unterklassen - Tabelle Table of sub classes

Z e i l e	Unterklasse : Sub class	Gruppenaufstellung der Unterklassen : Table of sub class :																Zum Beispiel: A1 for example : 1-1		muss zusätzlich bestellt werden additional ordering nesesary					
	767...	A	B	C	D	E	F	G	H	J	K	L	N	O	P	Q	R	S	T	U	V	W	X...	Y	Z
01	73	1	1	1+2	1	1	2	1	1	1	1	1	1	2	1	2	2	1+6	-	-	2	-	-	1	
02																									
03	FA-73	1	1	1+2	1	1	2	1	1	1	1	1	1	2	1	2	6	2+6	1+2	3	2	-	-	1	
04																									
05	LG-73	1	1	1+2	1	1	2	2	1	1	1	1	1	2	1	1	3	1+4	-	-	2	-	XB1	1	
06																									
07	LG-74	1	1	1+2	1	2	1	2	1	1	1	1	1	2	1	1	3	1+4	-	-	2	-	XB1	1	
08																									
09	AE-73	1	2	1+2	1	1	4	4	1	3	3	2	2	-	1	1	3	1+4	-	-	2	1	-	1	
10	AE-5-73	1	2	1+2	1	1	3	4	1	3	3	2	2	-	1	3	11	1+4		4					
11	373	1	1	1+2	1	1	2	1	1	1	1	1	1	1	2	1	2	1+6	-	-	2	-	-	1	
12																									
13	FA-373-RAP-HP	1	1	1+2	1	1	2	1	1	1	1+1.1	1	1	1	2	2	6	2+6	1	3	2	-	-	1	
14																									
15	FAS-373-RAP-HP	2	1	1+2	2+4	1	2	1	1	1	1+1.1	3	1	1	2	2	6	2+6	1	3	2	-	-	1	
16																									
17	FAS-573-RAP-HP	2	1	1+2	2+4	1	5	1	1	1	1+1.1	3	1	1	2	3	7	2+6	1	3	4	-	-	1	
18																									
19	KFA-373-RAP-HP	2	1	1+2	2+3	1	2	5	1	1	1+1.1	3	1	1	2	4	8	2+6	1	3	2	-	-	1	
20	KFA-573-RAP-HP	2	1	1+2	2+3	1	5	5	1	1	1+1.1	3	1	1	2	5	10	2+6		3					
21	FA-374	1	1	1+2	1	2	1	1	1	1	1	1	1	1	2	2	6	2+6	1+2	3	2	-	-	1	
22																									
23	VF-373	1	1	1+2	1	1	4	3	1	2	2	2	1	1	2	2	5	3+4	1	4	1	-	XA1	1	
24	VF-573	1	1	1+2	1	1	3	3	1	2	2	2	1	1	2	3	9	3+4	1	4	3				
25	-273	1	1	1+2	1	1	2	6	2	1	1	1	1	1	2	1	1+2	1+5	-	-	2	-	-	1	
26																									
27	FA-273	1	1	1+2	1	1	2	6	2	1	1	1	1	1	2	2	5+6	2+5	1	3	2	-	-	1	
28	FAS-473-RAP-HP	2	1	1+2	2+4	1	5	6	2	1	1+1.1	3	1	1	2	3	7+9	2+5	1	3	4	-	-	1	

Zusatzeinrichtungen Additional equipment

	Teile-Nr. Parts-No.	Z...
32	RAP 13-2	767 59 003 4 ZA 1
33	RAP 13-6	767 59 014 4 ZA 2
34	RAP 13-7	767 59 018 4 ZA 3
35	HP 13-7	767 59 004 4 ZA 4
36	FLP 13-4	467 36 780 9 ZA 6
37	RSP 13-2	467 36 781 9 ZA 7
38	NP 13-4	467 36 779 9 ZA 9
39	KP 13-1	467 36 812 9
40	LR 13-1	467 36 803 9 ZA 19
41	WE-6	9781 000002 ZA 13
42	pneum. Anschlußteile	0797 003031 ZA 10
43	KN6	798 783001 ZA 12
44	NK 13-1	467 36 795 9 ZA 17
45	Anbausatz K	9880 767001 ZA 14
46	LR 13-4	767 59 00094 ZA 15
47	STLS 13-2	767 36 765 9 ZA 16
48	Anbausatz K	0907 487519 ZA 18
49	Nähleuchte	9822 510001 ZA 18
50	Lichtleiter Nähleuchte	9822 510125 ZA 14
51	SP 470	467 34754 9
52	WTA-13-2	767 59 0064
53	FLP 13-2	767 59 0054 ZA 8
54	FLP 13-2	367 36 764 9 ZA 8
55	RFW 13-3	767 36 762 9
56	RFW 13-8	767 59 0194
57	RAP 13-4	467 59 0034 ZA 11
58	FS 13-1	767 59 0204
59	RFW 13-9	767 59 0234
60	RFW 13-6	767 59 0244
61	RAP 13-8	767 59 0254 ZA 20

- (25) Bildtafel Illustration
- (26)
- (27)
- (28)
- (29)
- (27)
- (29)
- (30)
- (29)
- (31)
- (27) ab 1.99
- (27) bis 12.98
- (25.2)
- (25.1)
- (3)
- (25.2)
- (25)

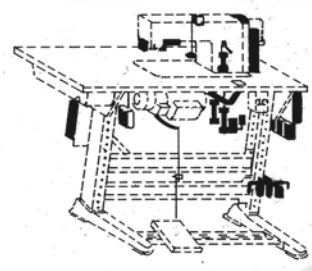

62	FSE 13-1	767 59 026 4		(25.3)
63	FSE 13-2	767 59 027 4		(30)
64	1LED Leuchte	9880 7670 11	Z 19	(30)
65				
66				
67				
68				
69				
70				
71				
72				
73				
74				
75				
76				
77				
78				

Lageplan Situation plan 767

A-D	=	①-①①
E-G	=	②
H	=	③
J, K	=	④
L-K	=	⑤
N-P	=	⑥
Q	=	⑥①
R	ohne FA with out FA	= ⑦-⑦①
R	mit FA with FA	= ⑧-⑧⑤
S, T	=	⑨
U, V	=	⑩-⑩②
W	=	⑪
X...	Elektro	⑮-⑮②
Y	=	⑲
Z...	=	⑳-⑳①
KP13-1	=	⑳⑧
Z...	=	⑳⑨-⑳⑭

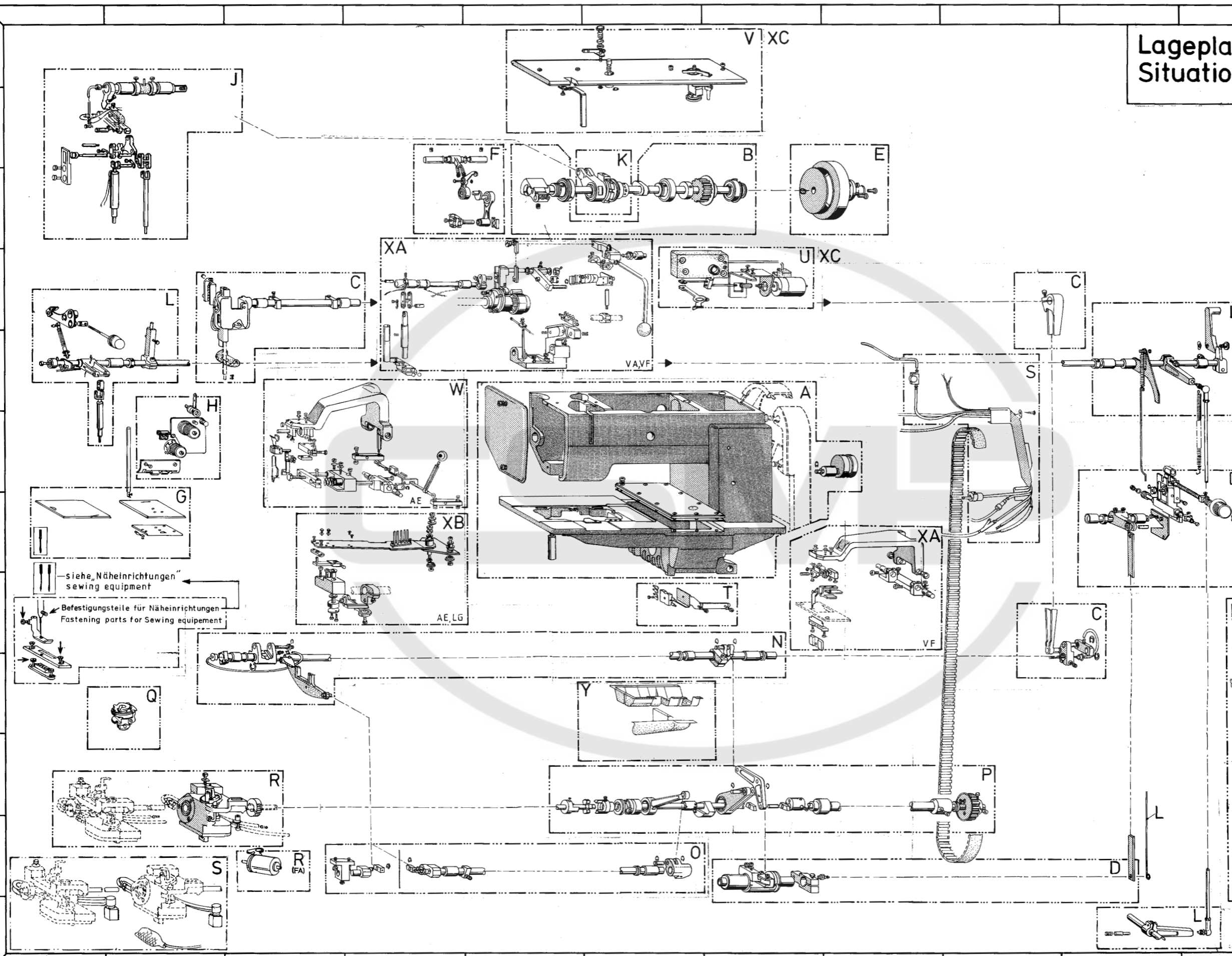

—siehe „Näheinrichtungen“
sewing equipment

Befestigungsteile für Näheinrichtungen
Fastening parts for Sewing equipment

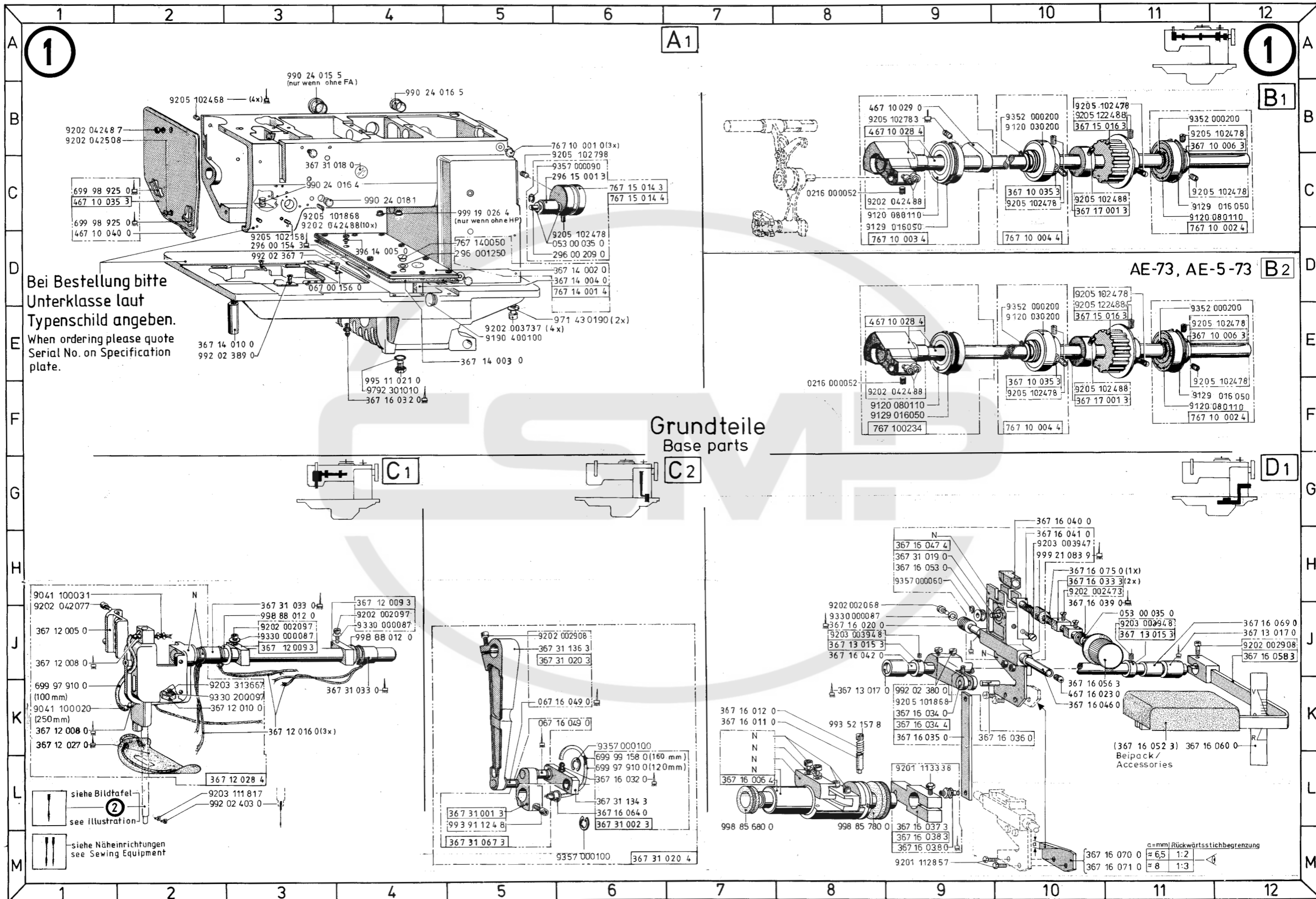

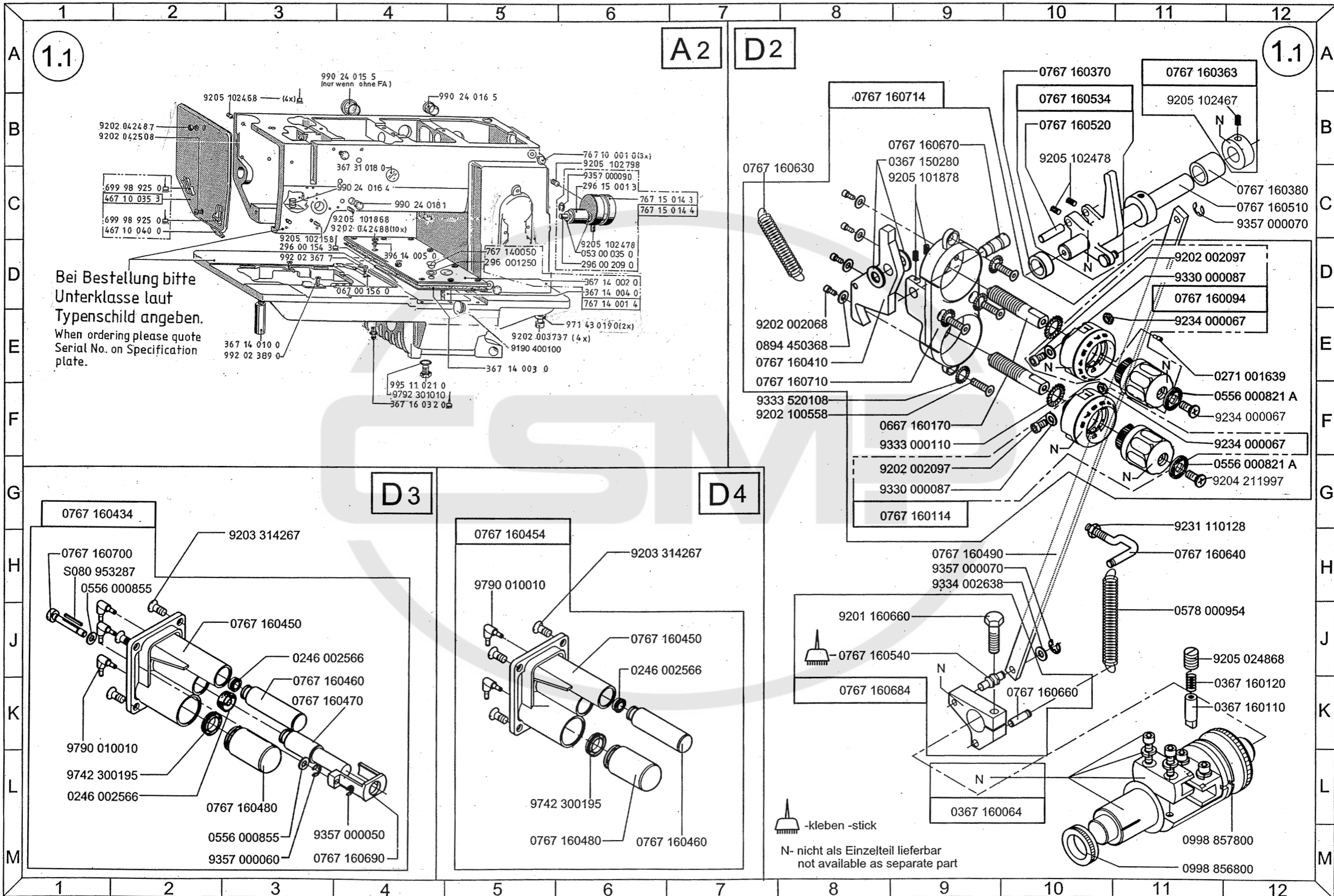

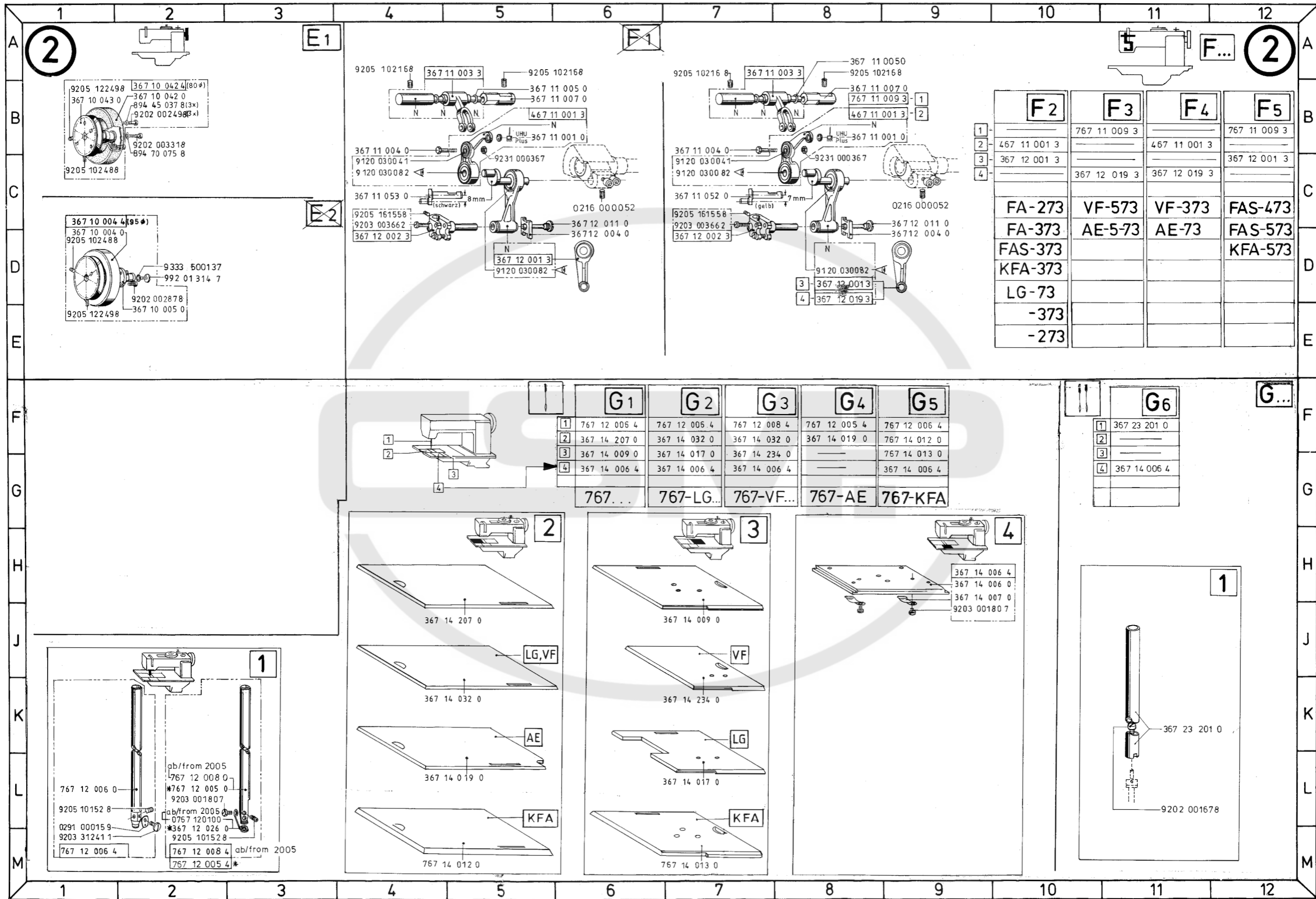

	F2	F3	F4	F5
1		767 11 009 3		767 11 009 3
2	467 11 001 3		467 11 001 3	
3	367 12 001 3		367 12 019 3	367 12 001 3
4		367 12 019 3	367 12 019 3	
	FA-273	VF-573	VF-373	FAS-473
	FA-373	AE-573	AE-73	FAS-573
	FAS-373			KFA-573
	KFA-373			
	LG-73			
	-373			
	-273			

	G1	G2	G3	G4	G5
1	767 12 006 4	767 12 006 4	767 12 008 4	767 12 005 4	767 12 006 4
2	367 14 207 0	367 14 032 0	367 14 032 0	367 14 019 0	767 14 012 0
3	367 14 009 0	367 14 017 0	367 14 234 0		767 14 013 0
4	367 14 006 4	367 14 006 4	367 14 006 4		367 14 006 4
	767...	767-LG...	767-VF...	767-AE	767-KFA

	G6
1	367 23 201 0
2	
3	
4	367 14 006 4

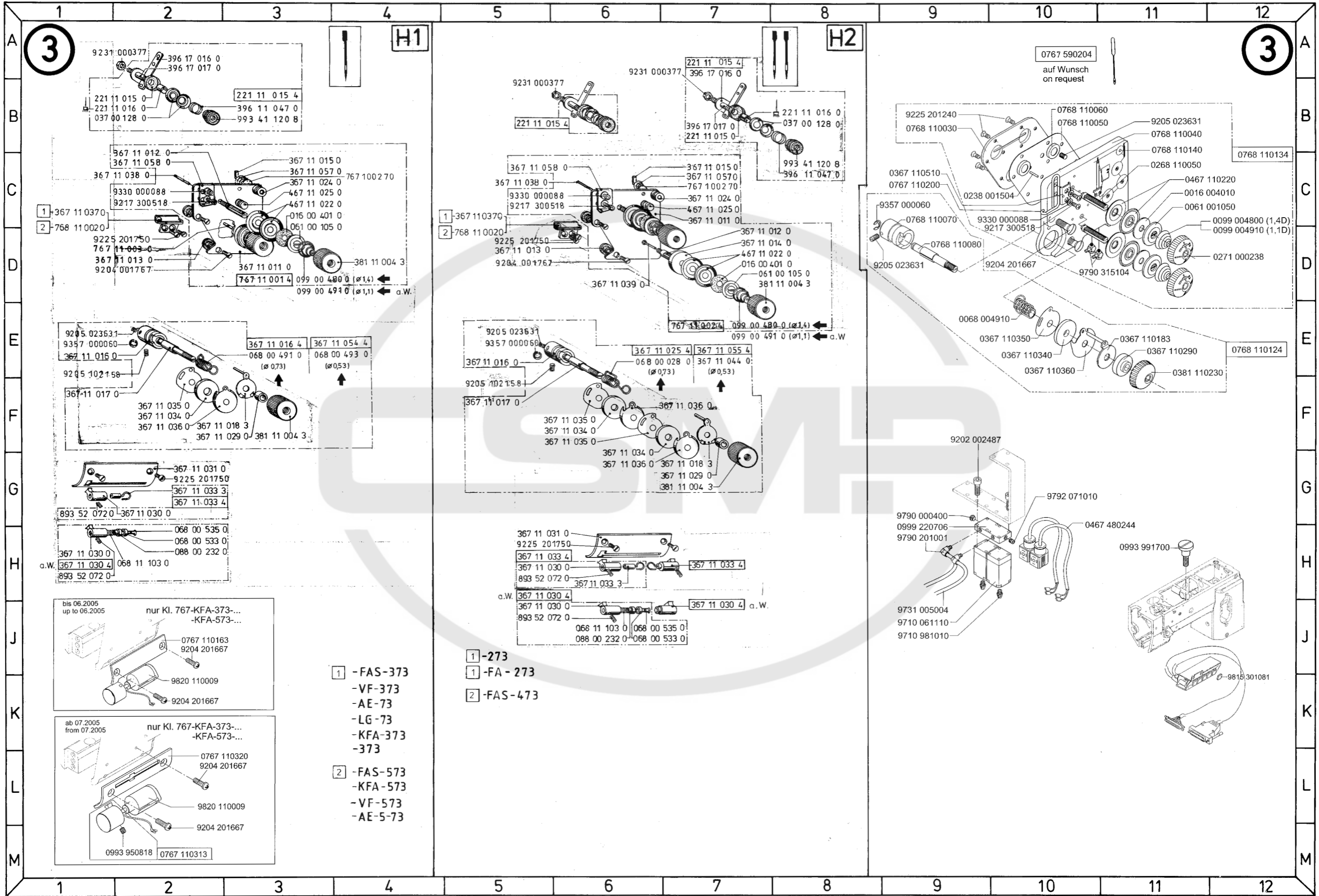

3

H1

H2

3

0767 590204
auf Wunsch
on request

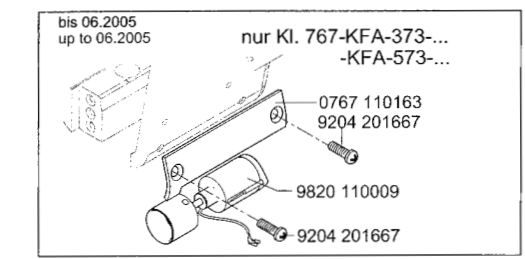
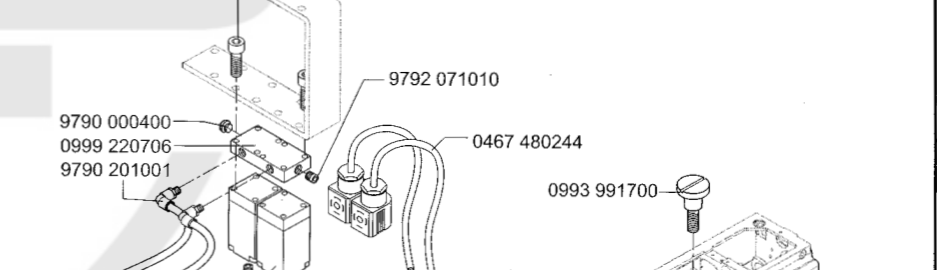
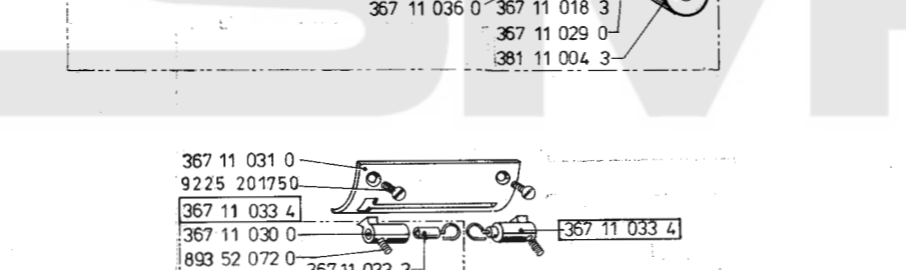
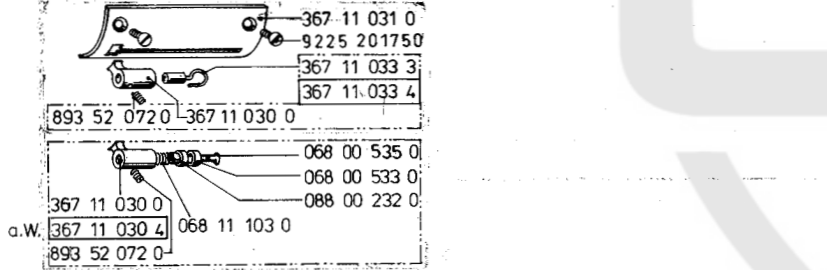
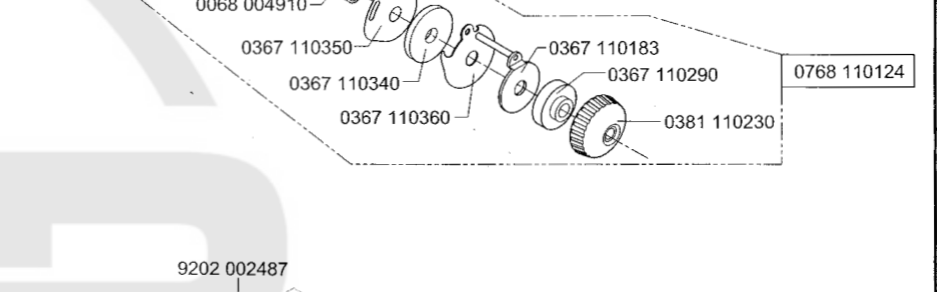
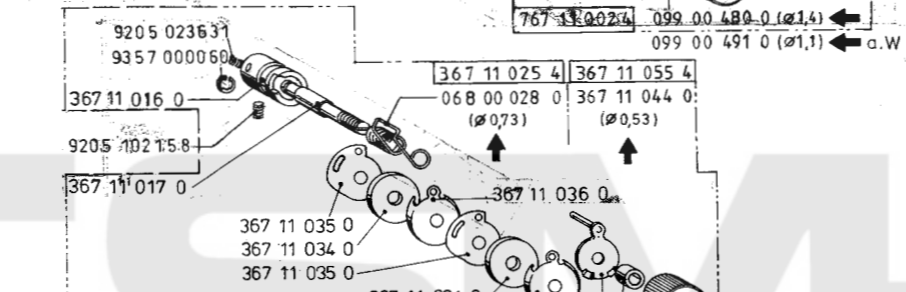
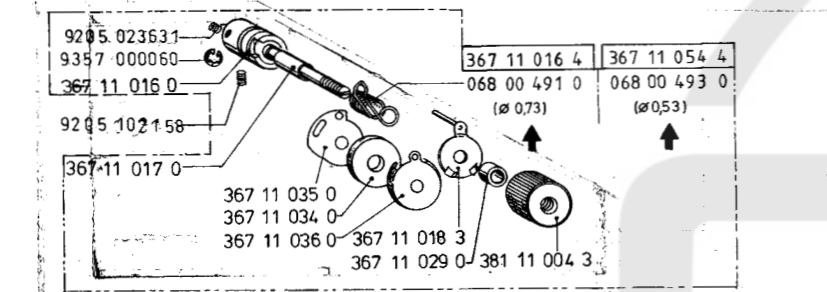
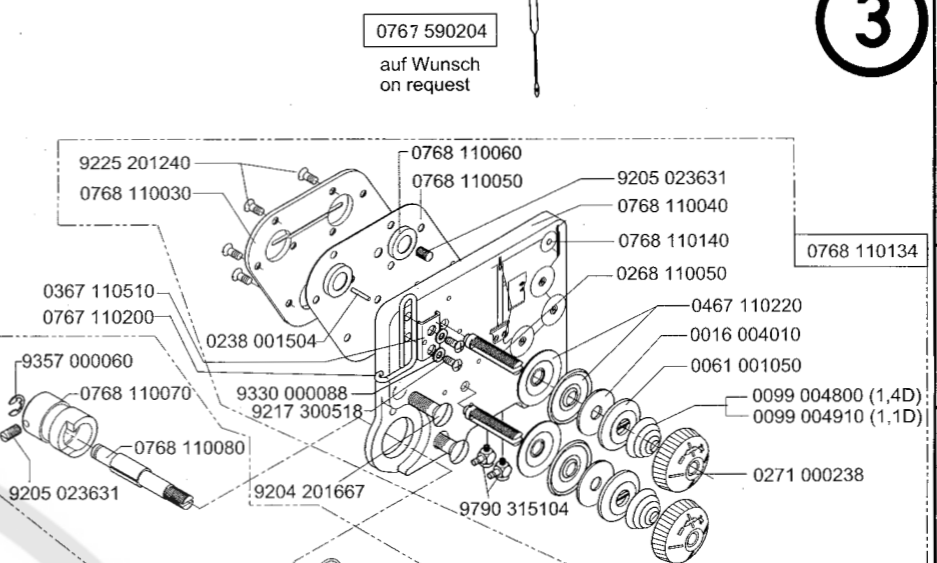
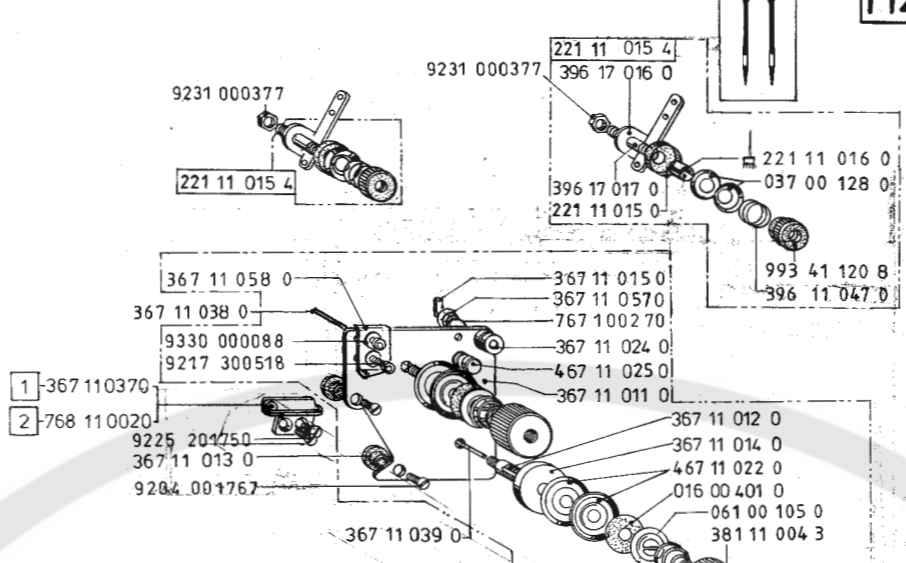
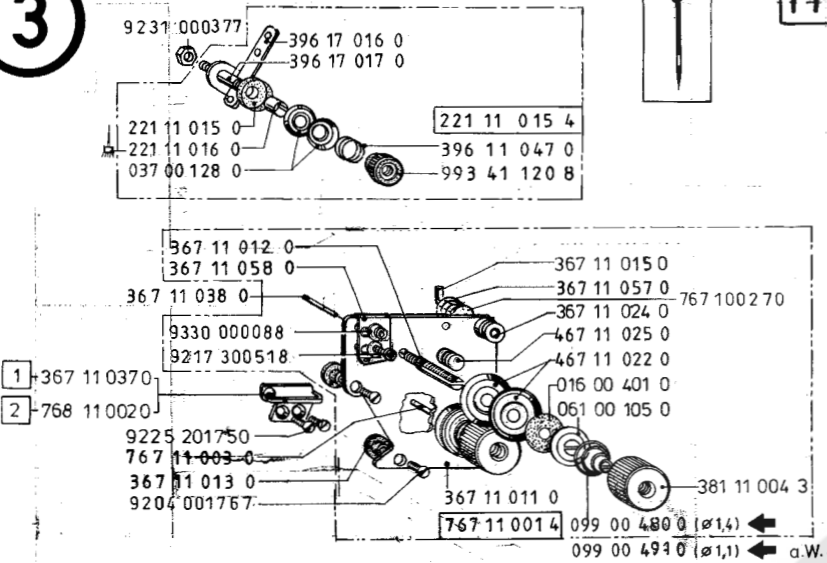

- 1 -FAS-373
- VF-373
- AE-73
- LG-73
- KFA-373
- 373

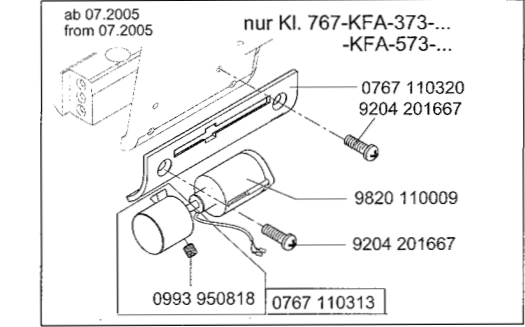

- 2 -FAS-573
- KFA-573
- VF-573
- AE-5-73

- 1 -273
- 1 -FA - 273
- 2 -FAS-473

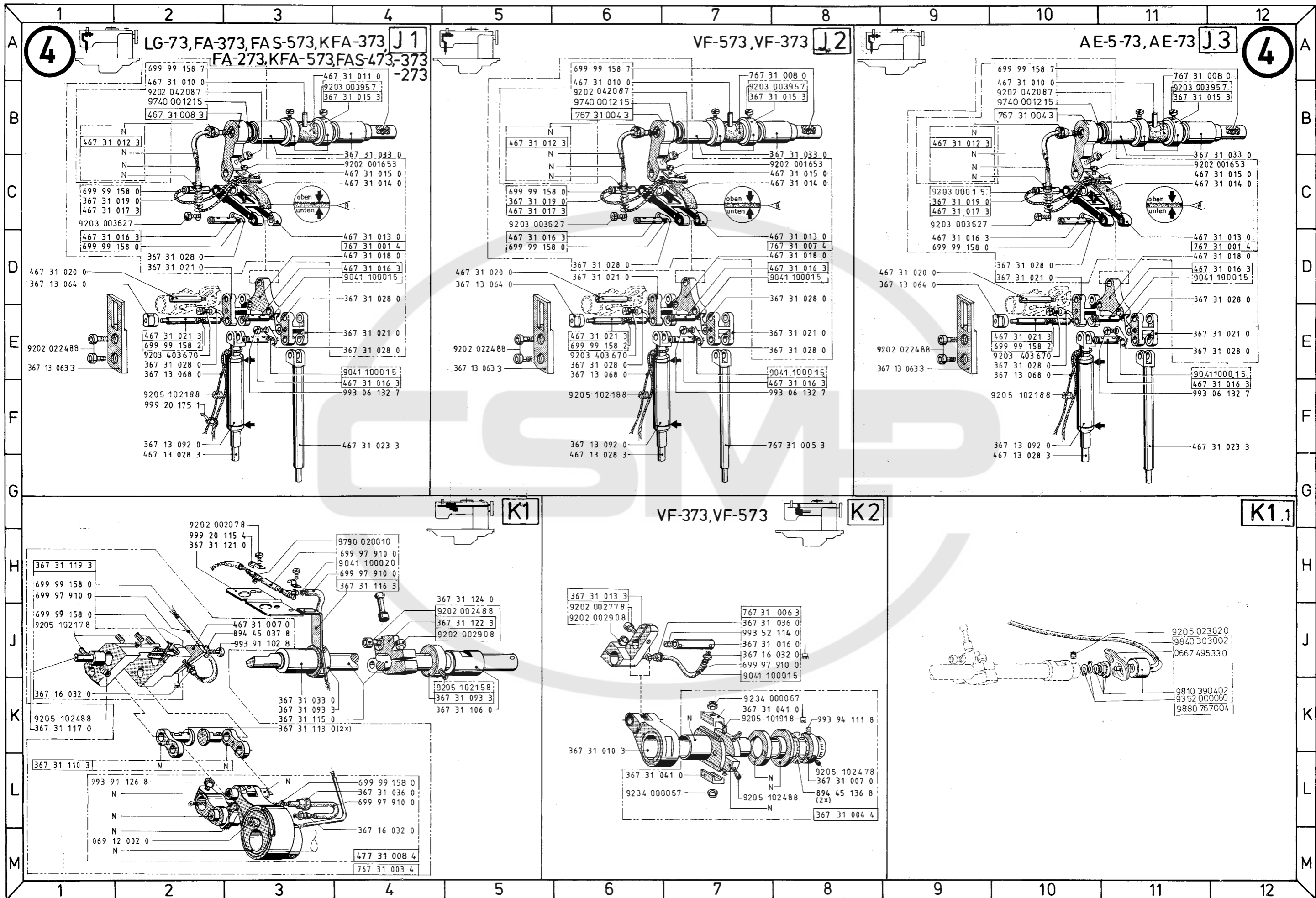

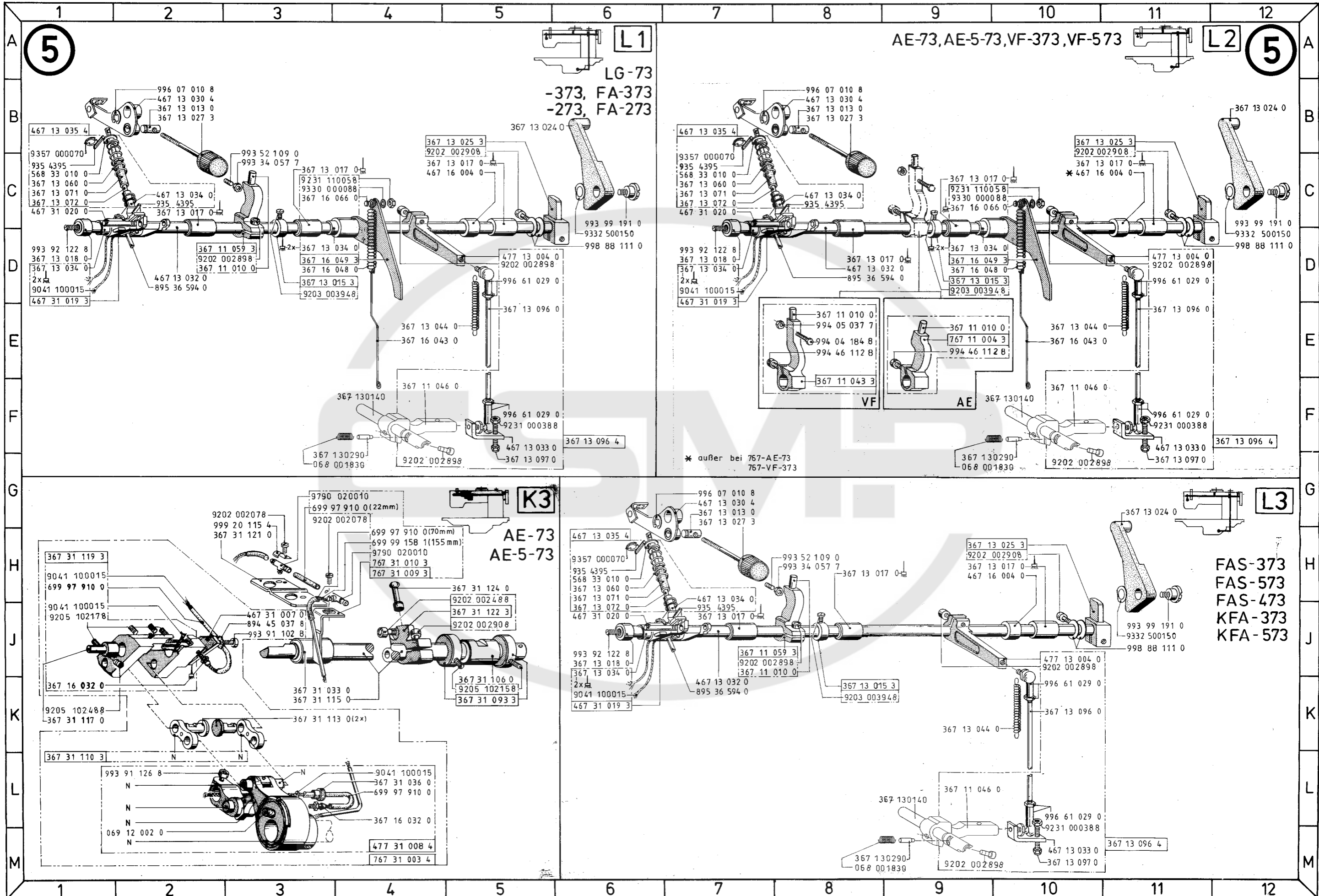

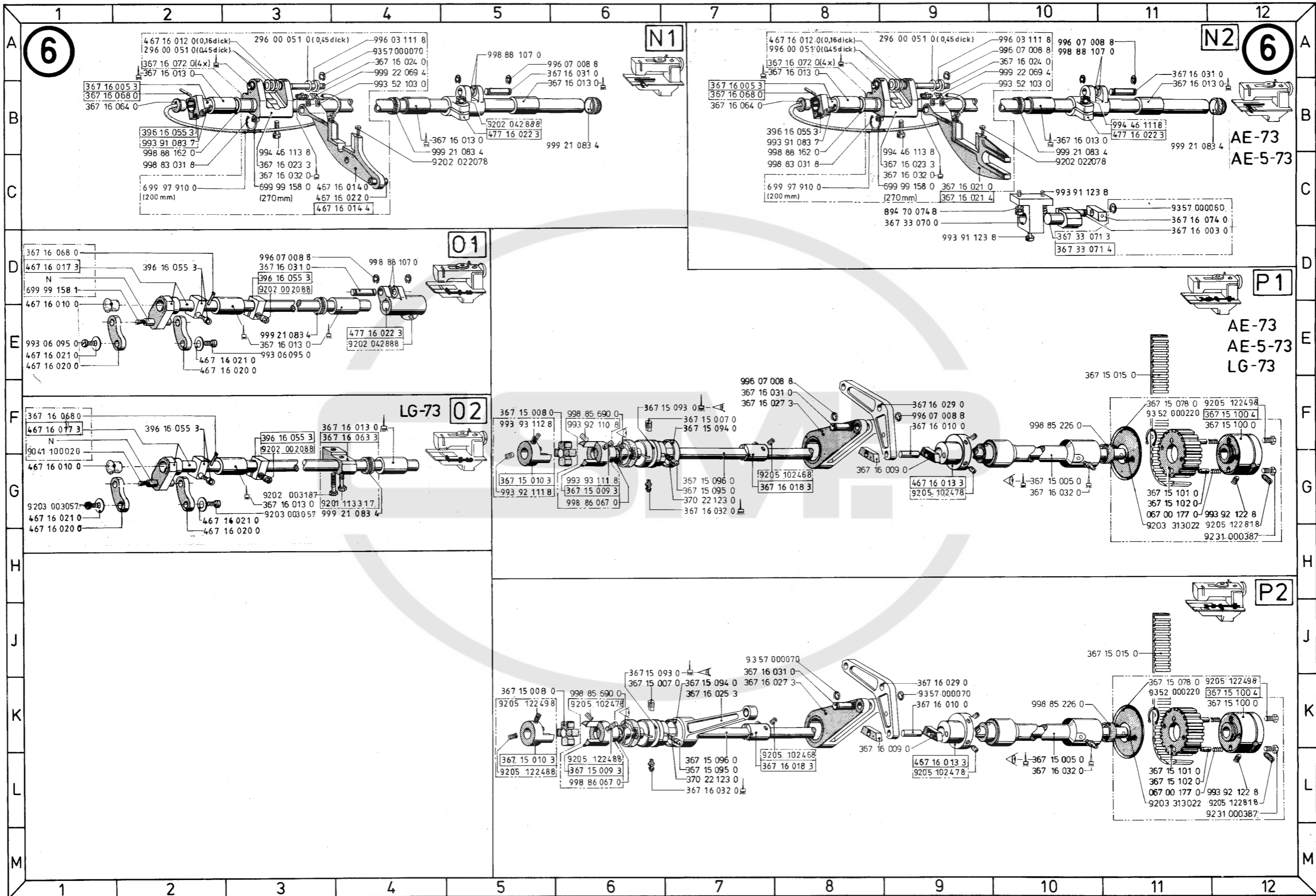

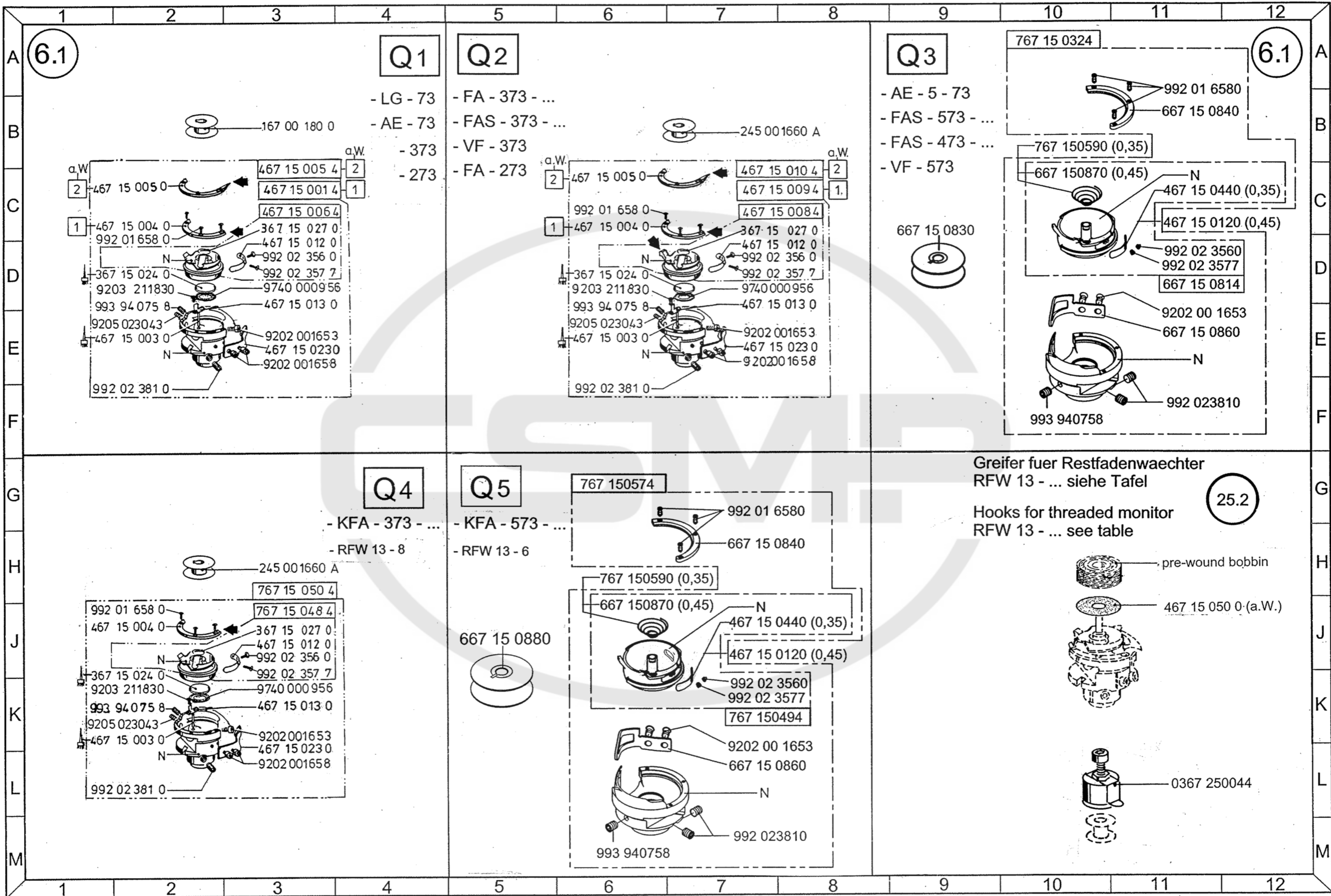

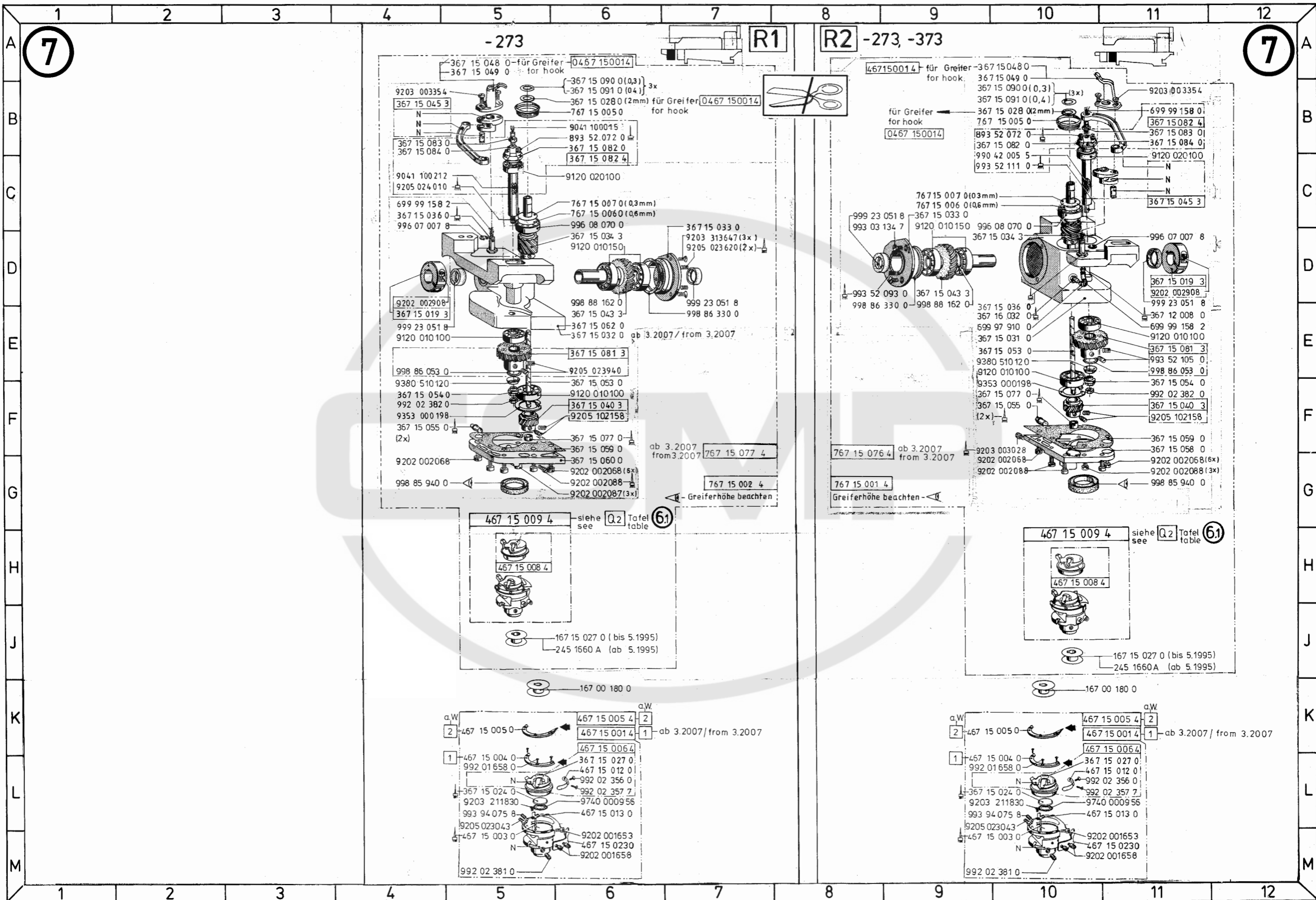

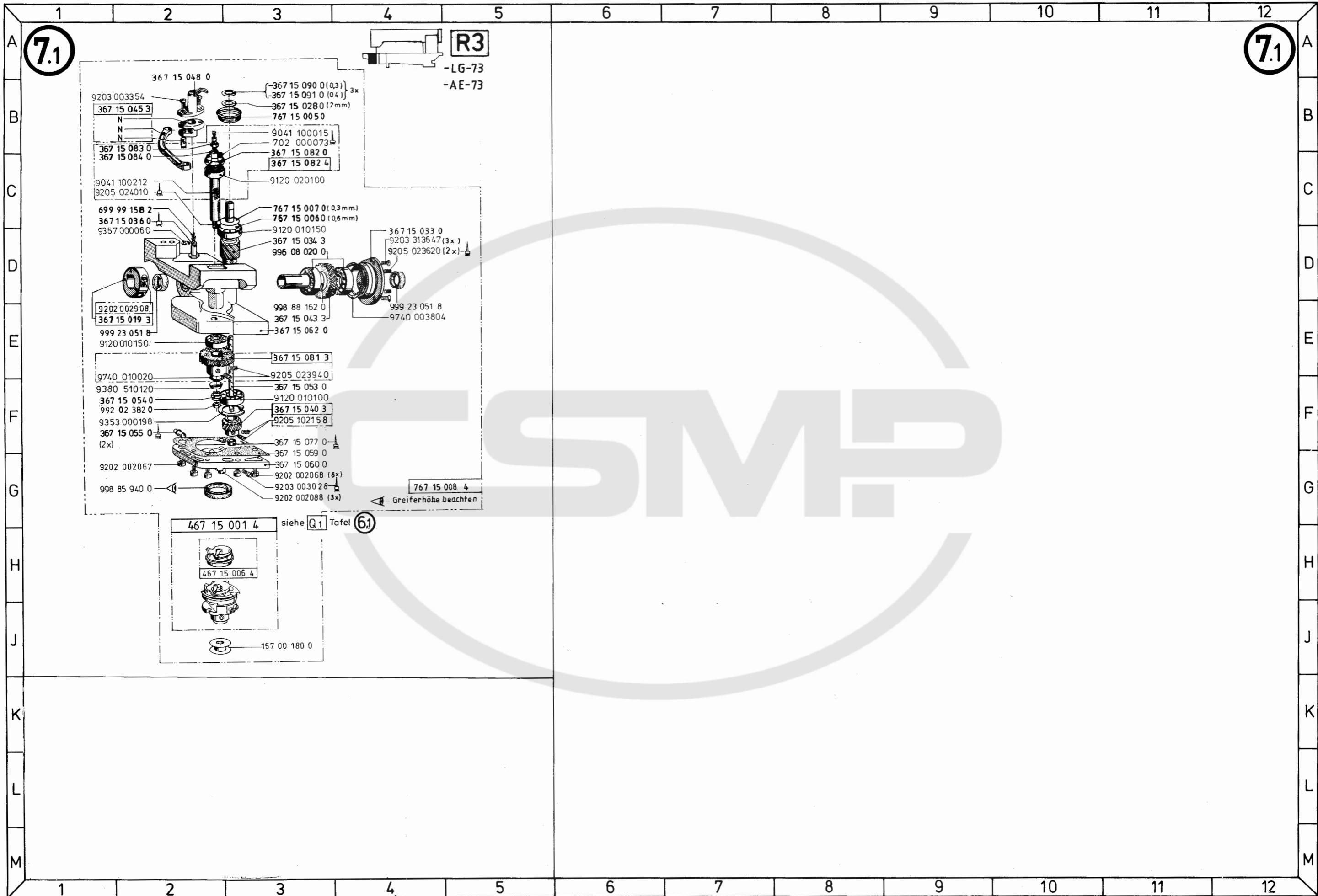

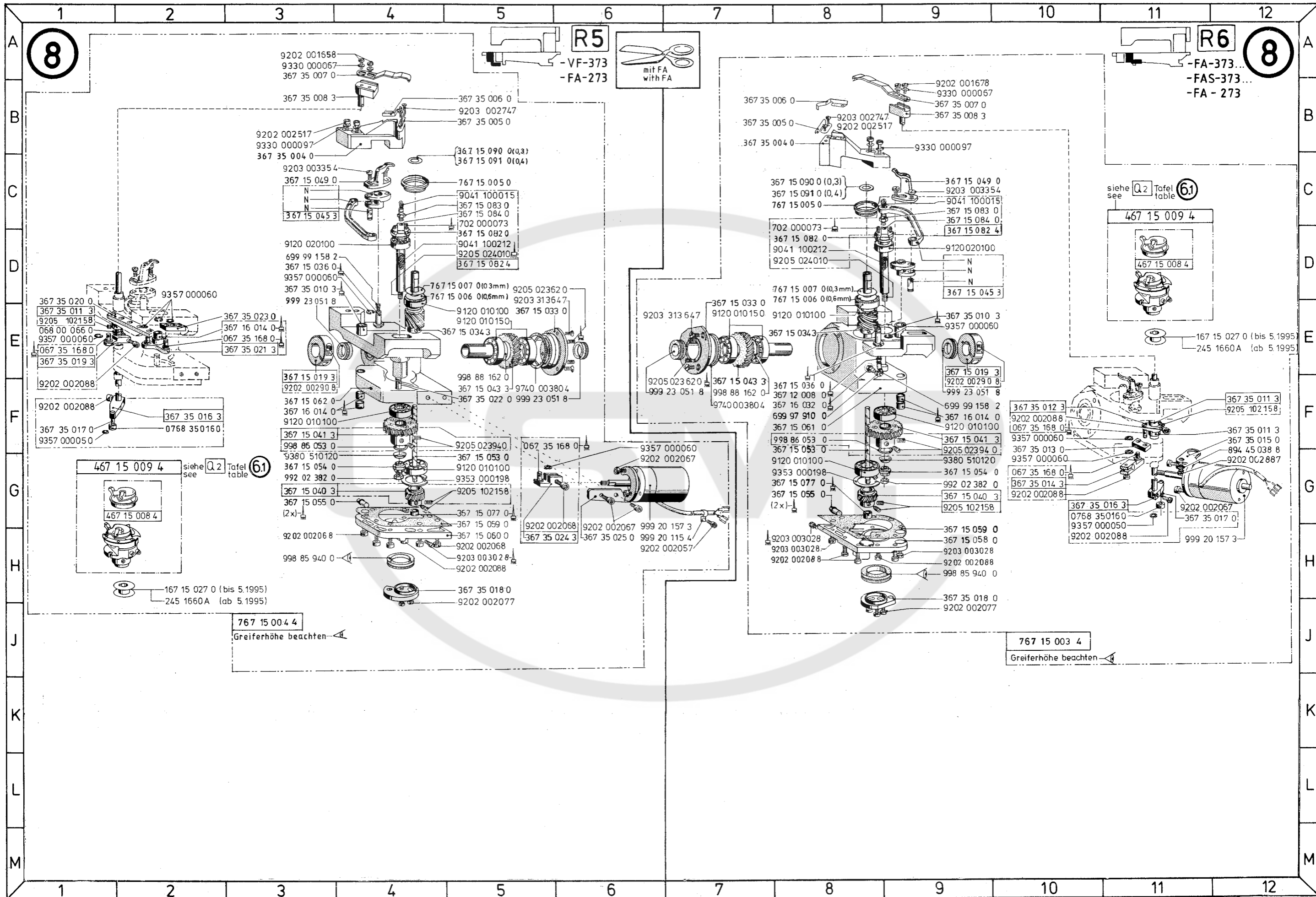

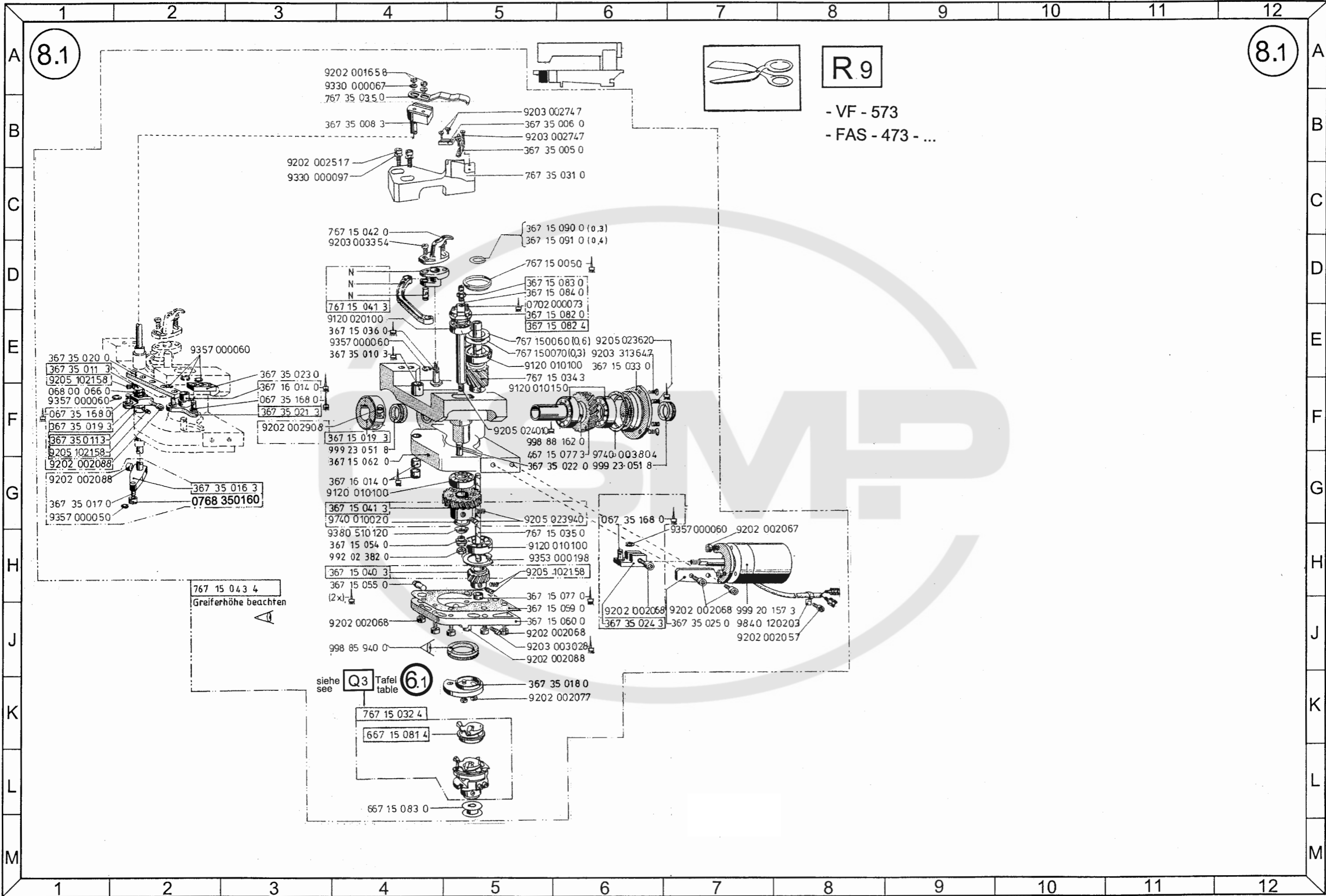

8.2

R7

8.2

- FAS - 573 - ...
- FAS - 473 - ...

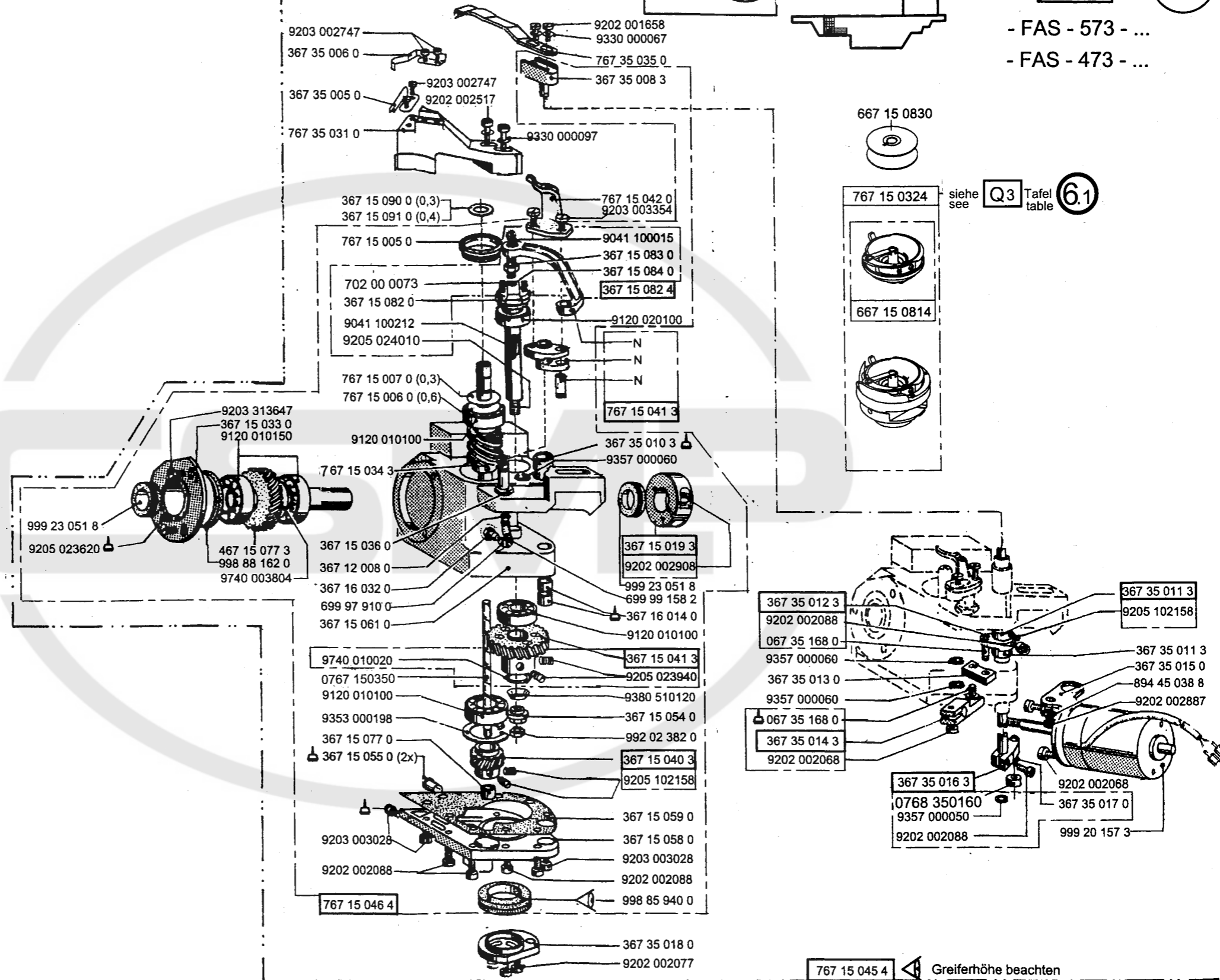

siehe Q3 Tafel 6.1

Greiferhöhe beachten

8.3

R.8

8.3

- KFA - 373 - ...

siehe Q4 Tafel 6.1
see table

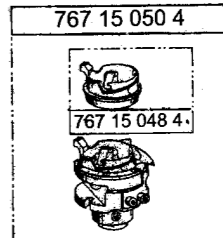

245 001660 A

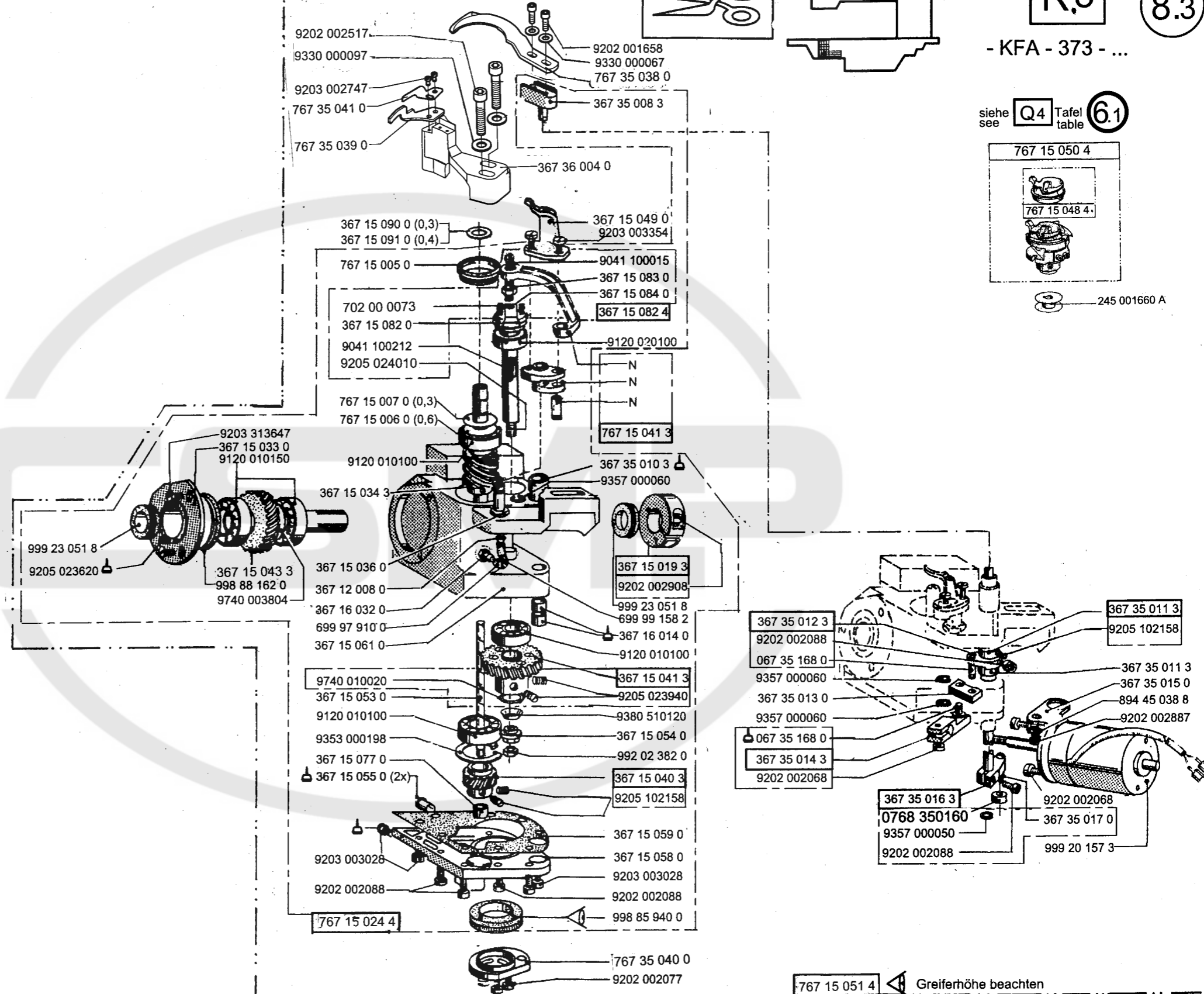

8.4

8.4

R10

- KFA - 573 - ...

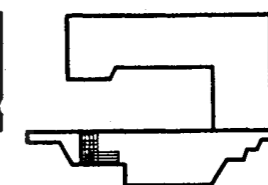
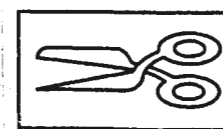

667 15 0880



siehe see Q5 Tafel table

6.1

767 15 0574



767 15 0494

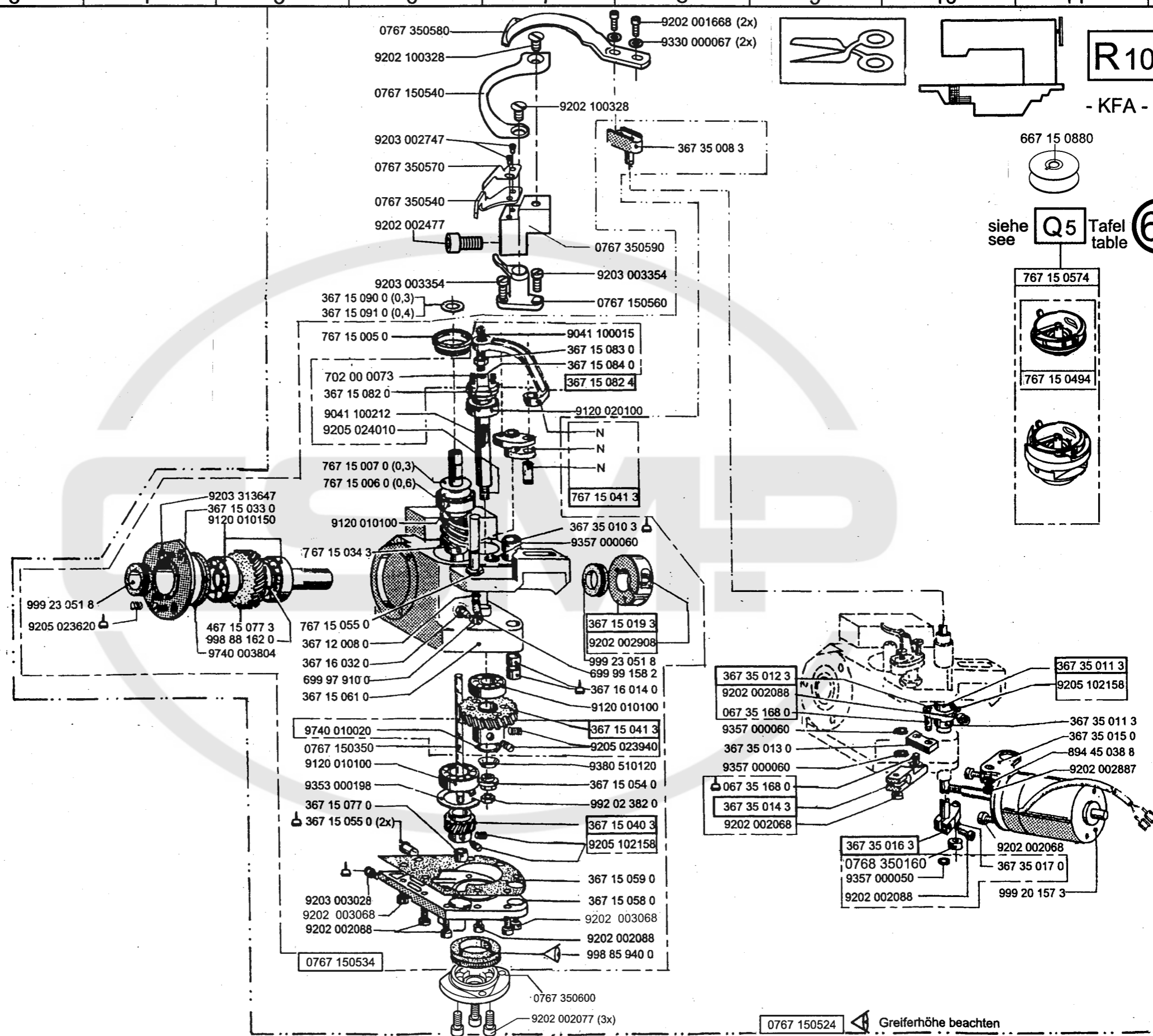
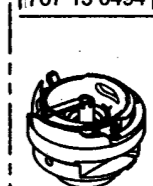

0767 150524 Greiferhöhe beachten

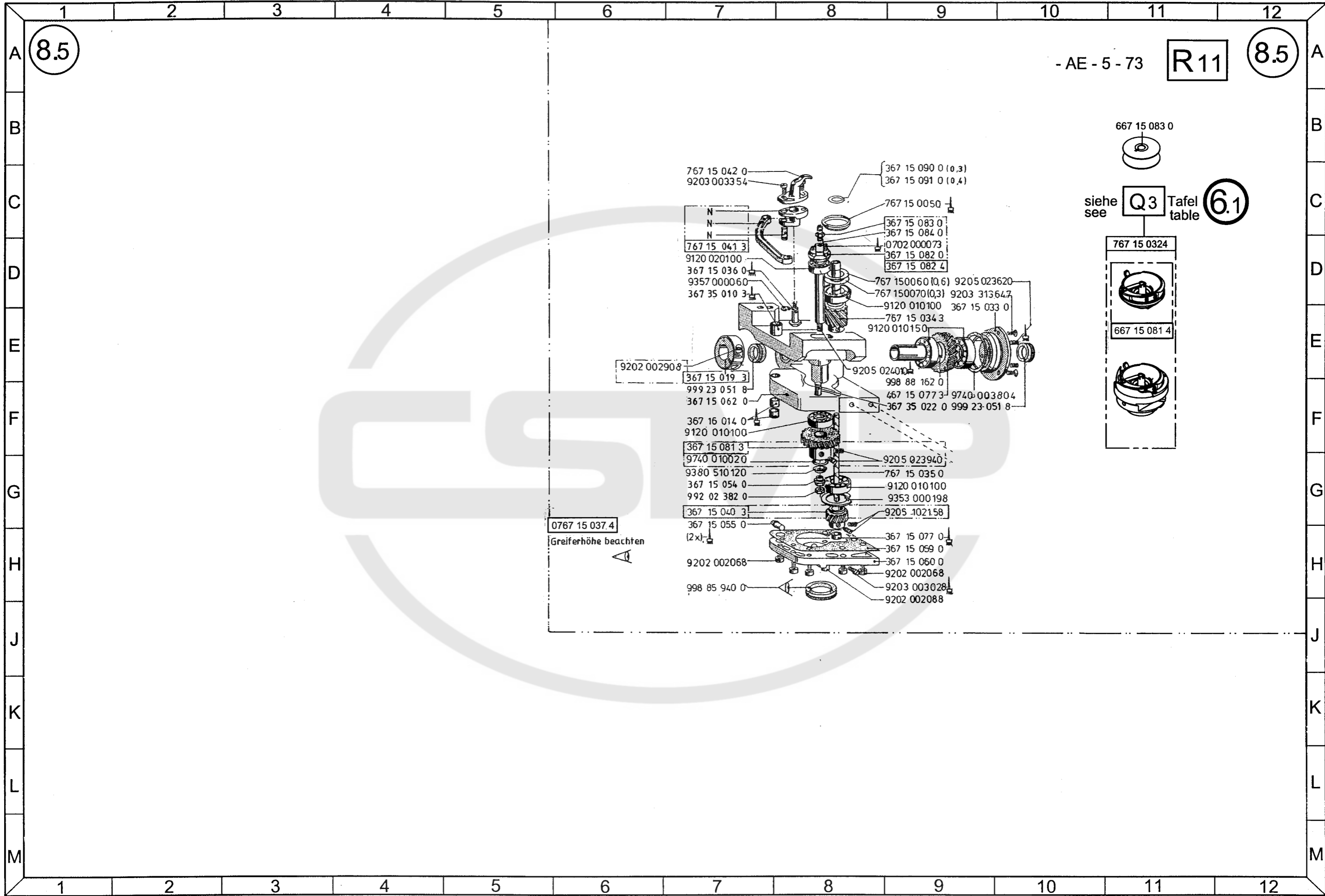

- AE - 5 - 73

R11

8.5

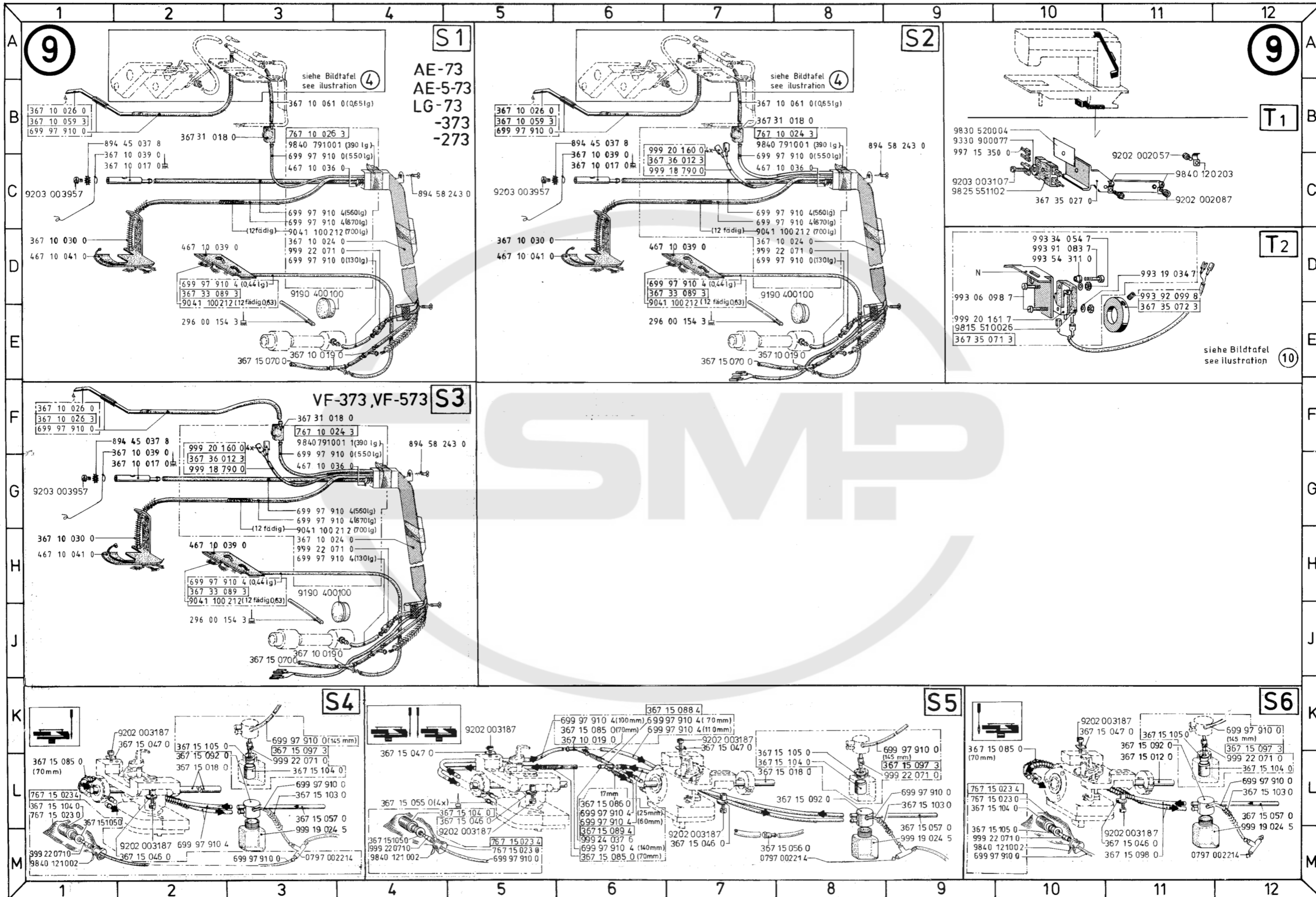

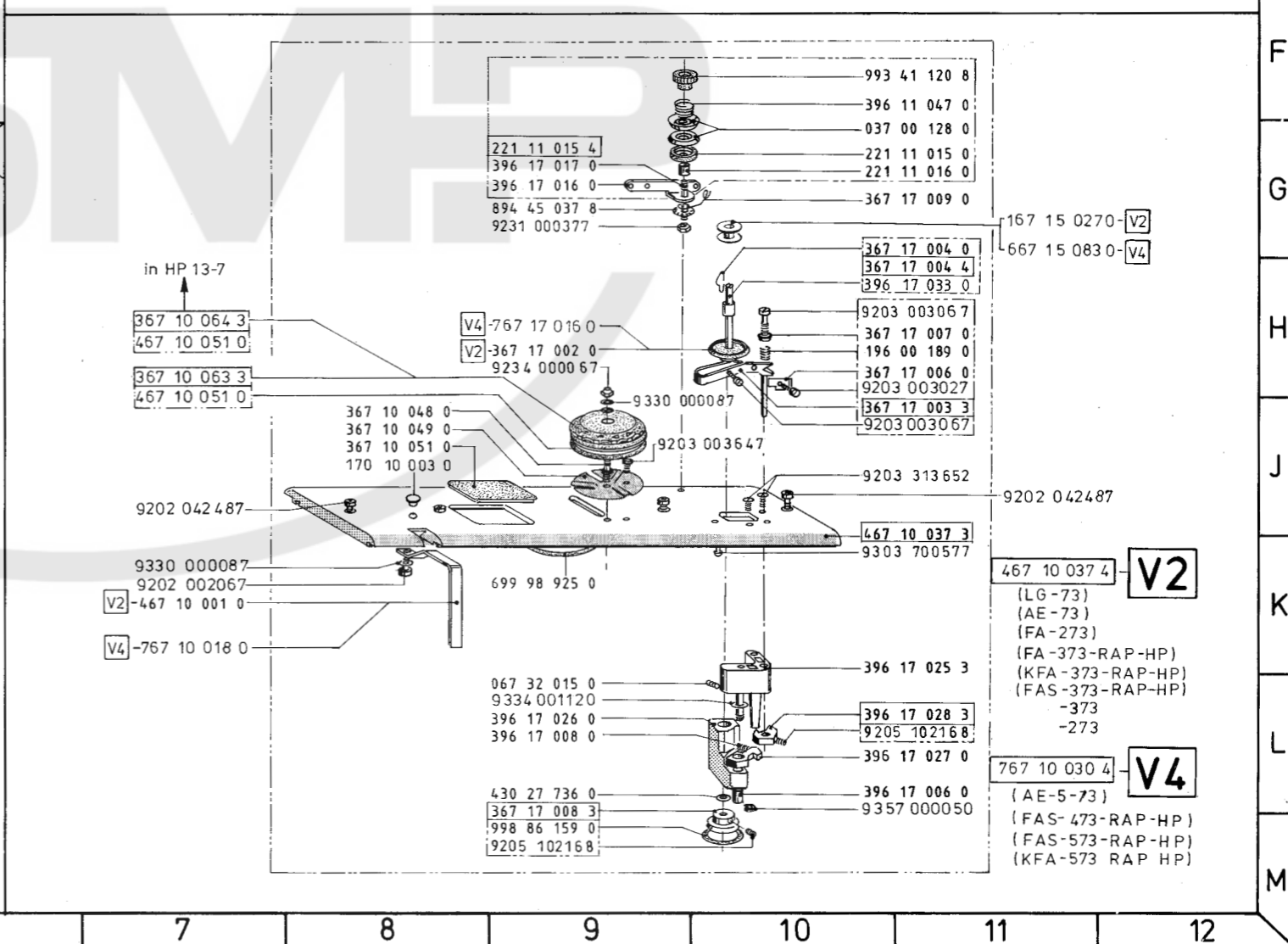
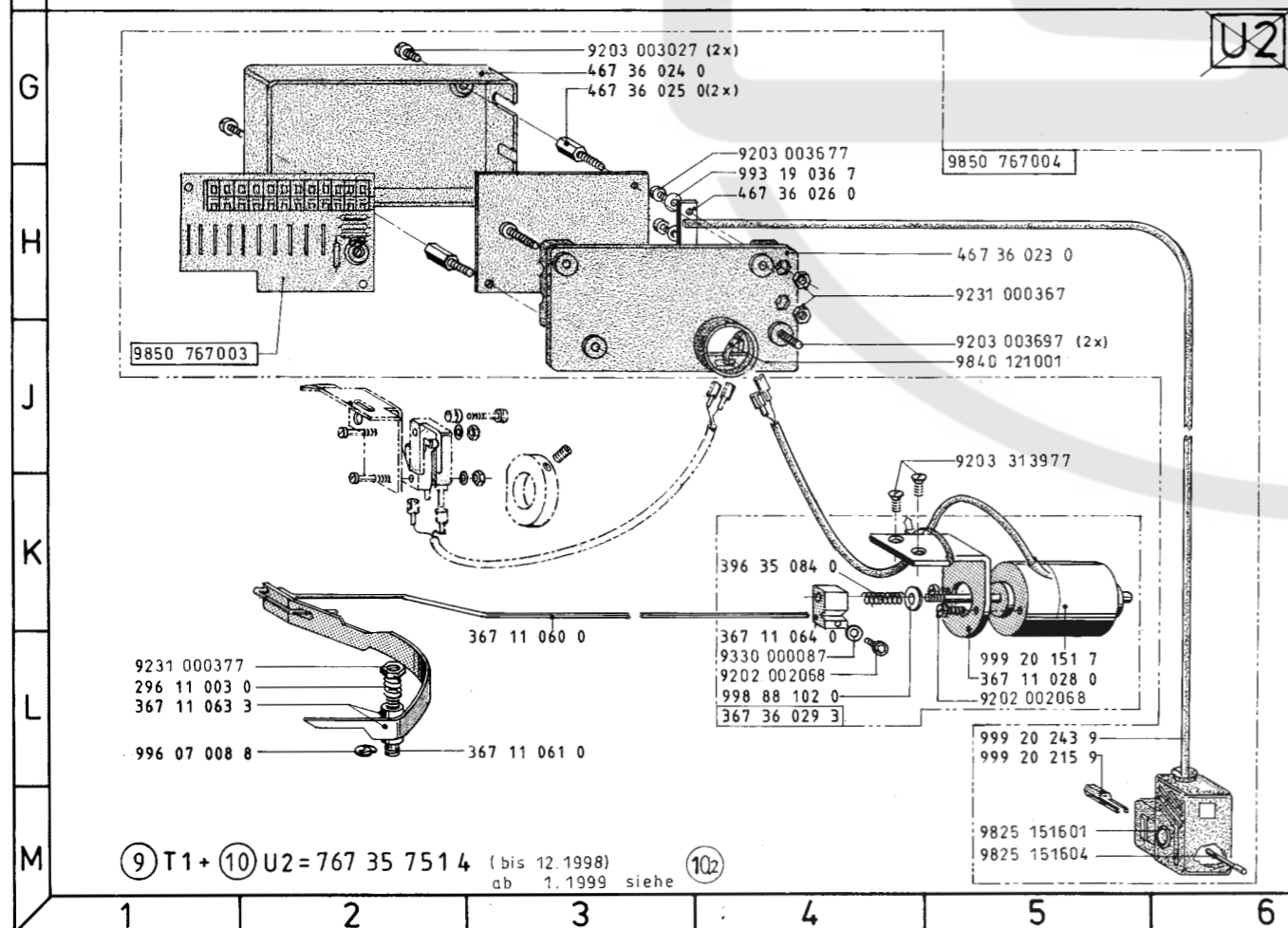
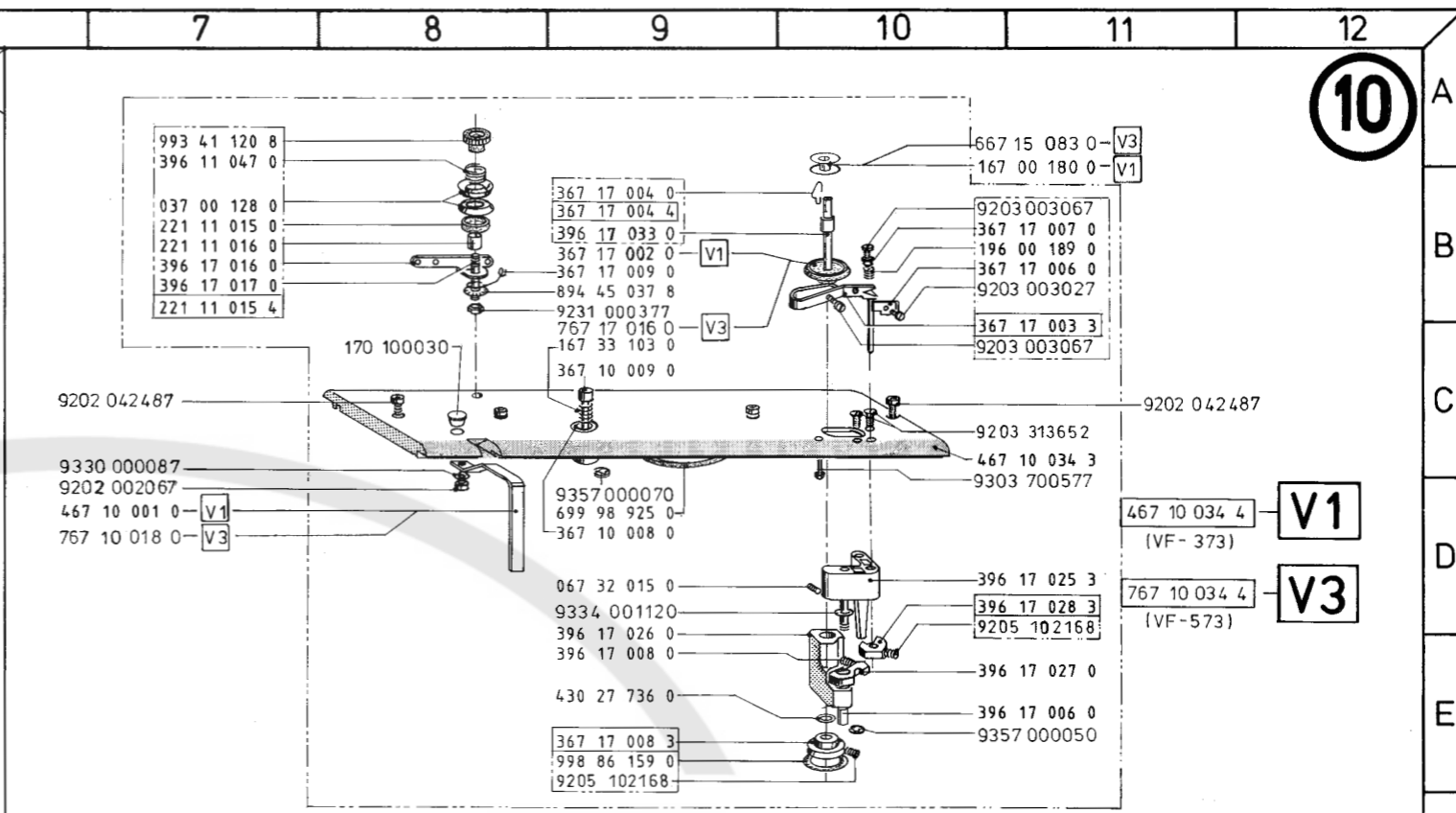
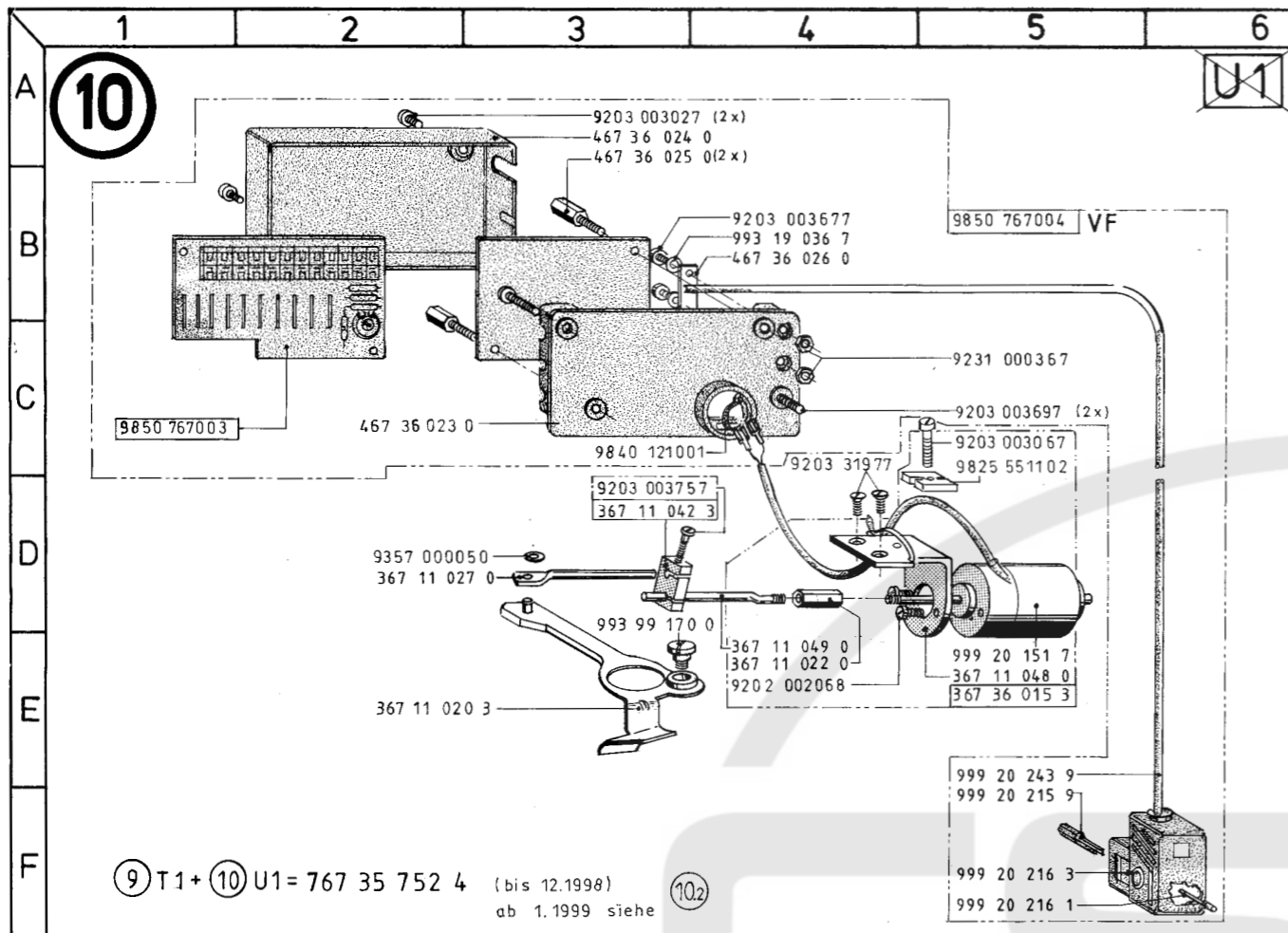

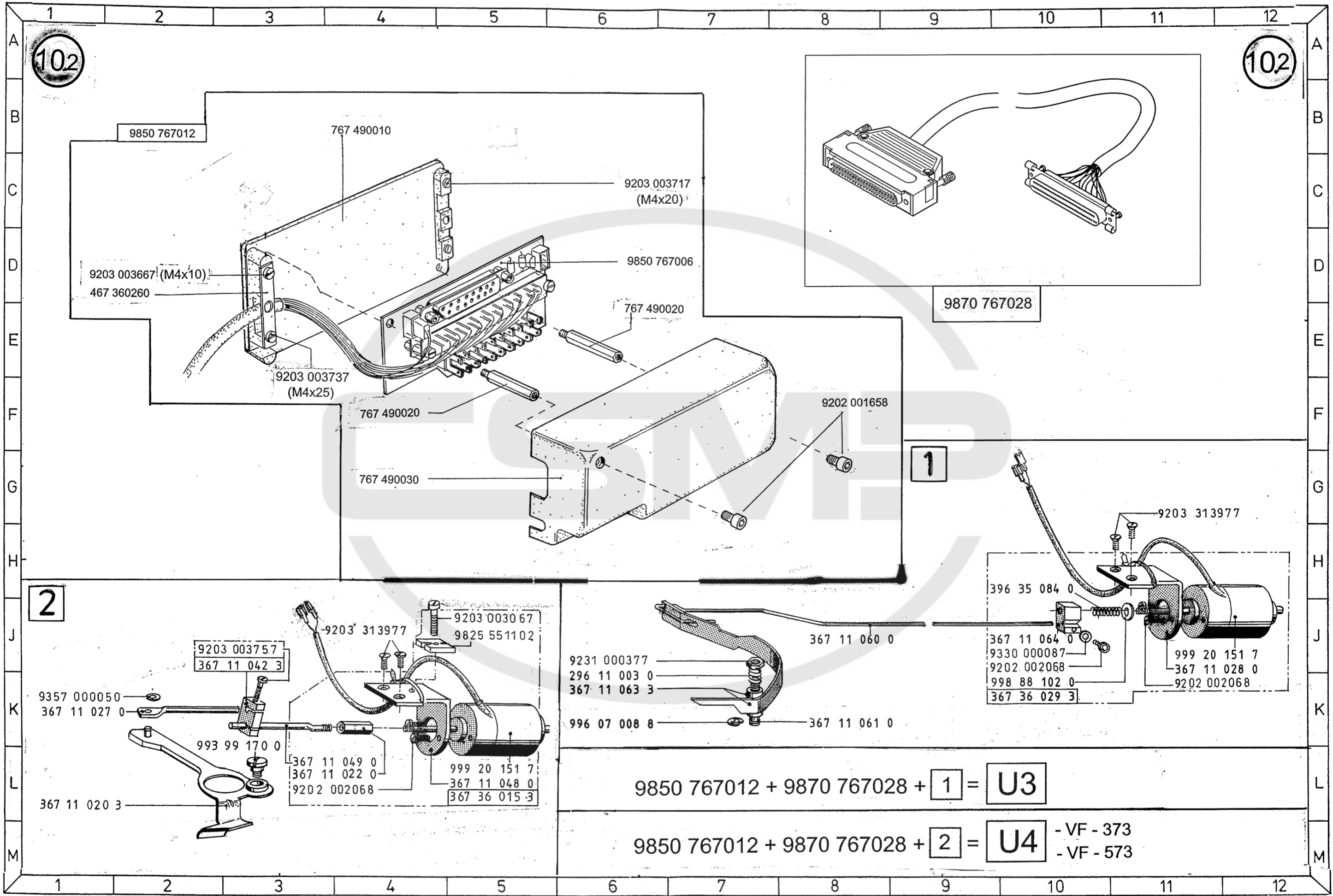

102

102

2

1

9850 767012 + 9870 767028 + **1** = **U3**

9850 767012 + 9870 767028 + **2** = **U4** - VF - 373
 - VF - 573

11

W1

11

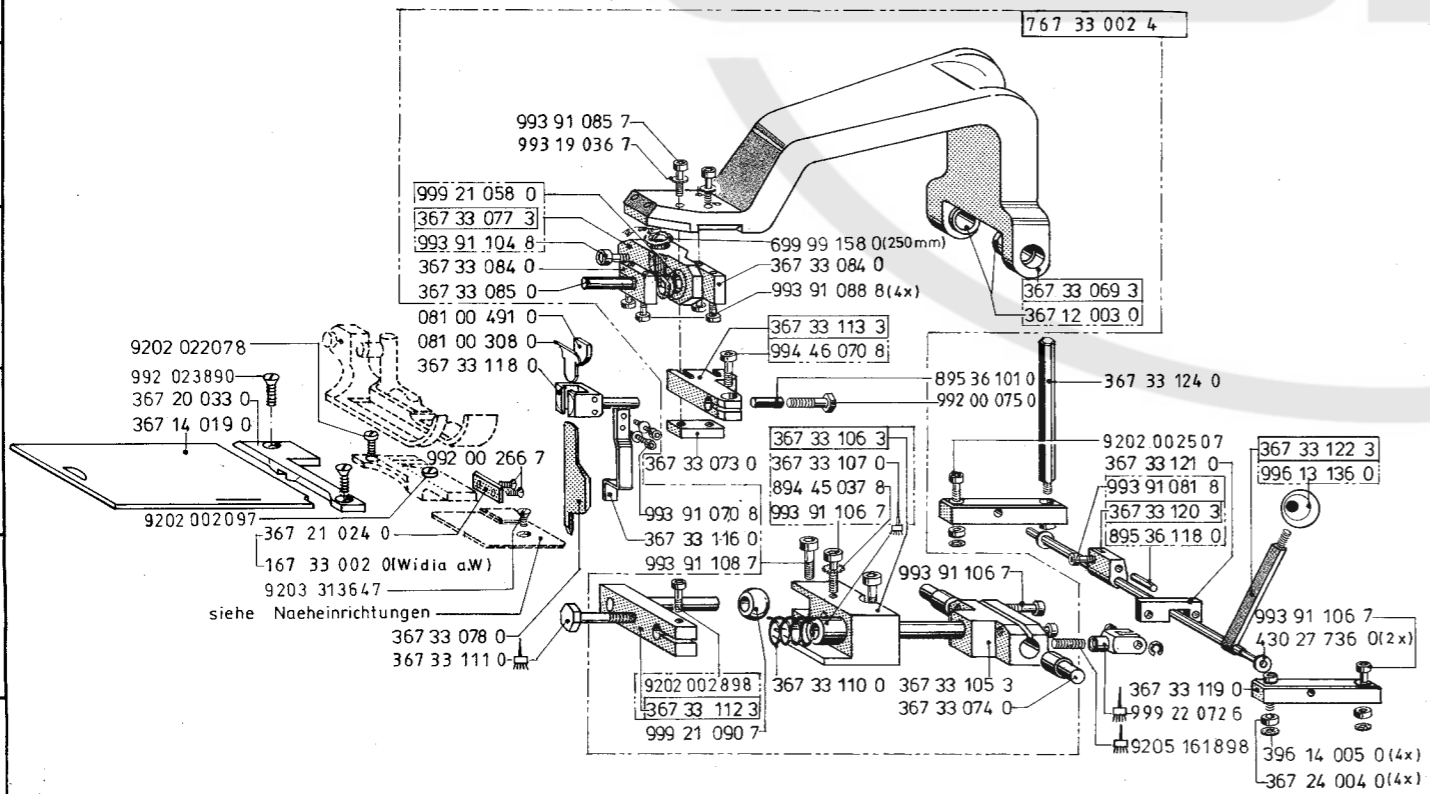
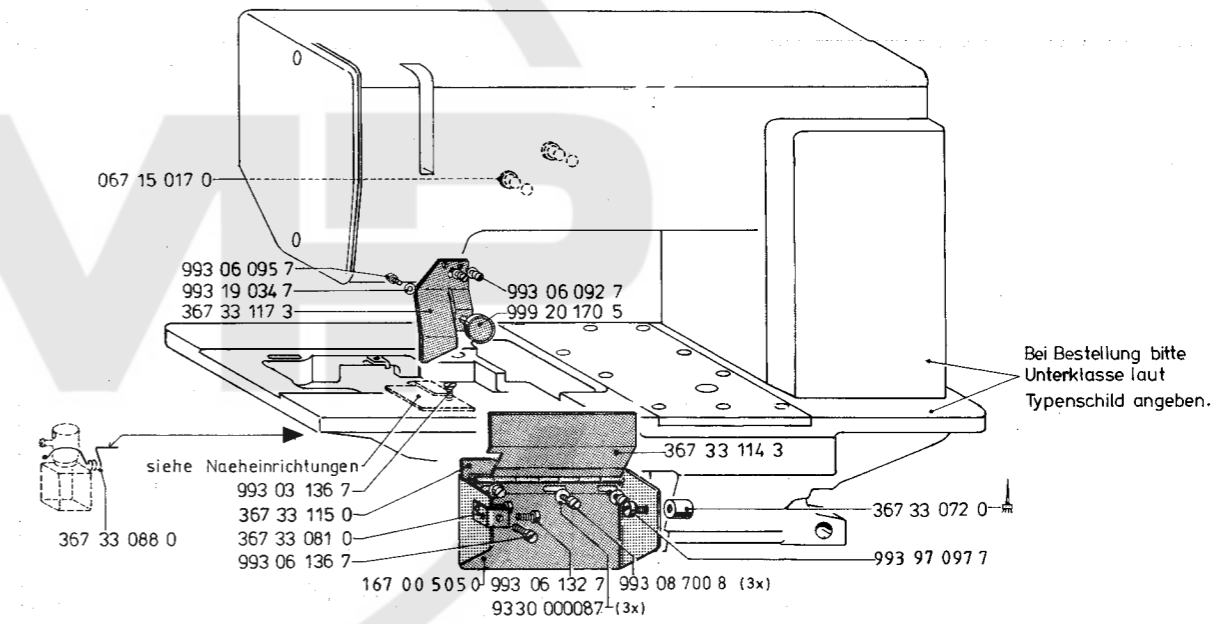
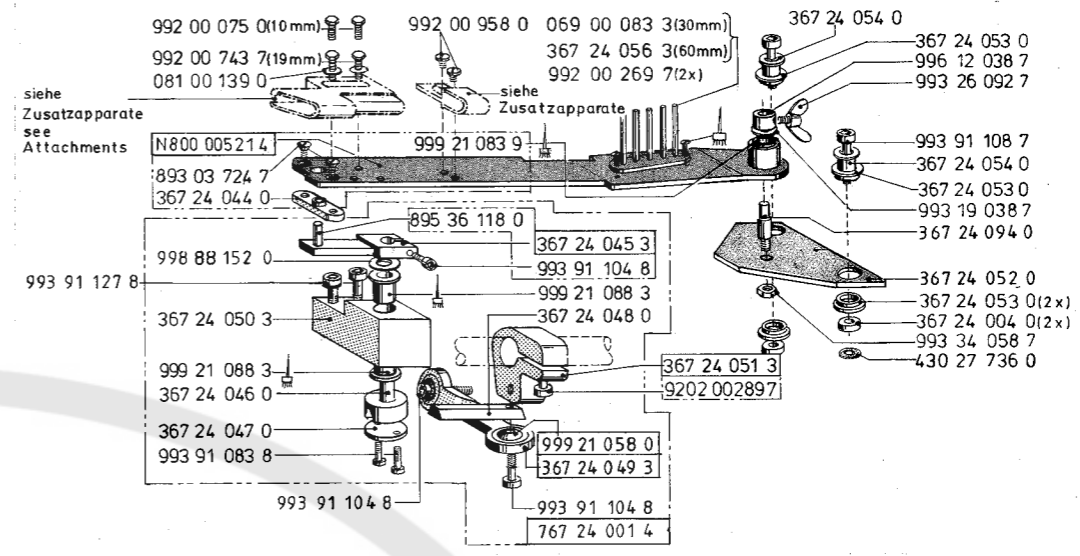
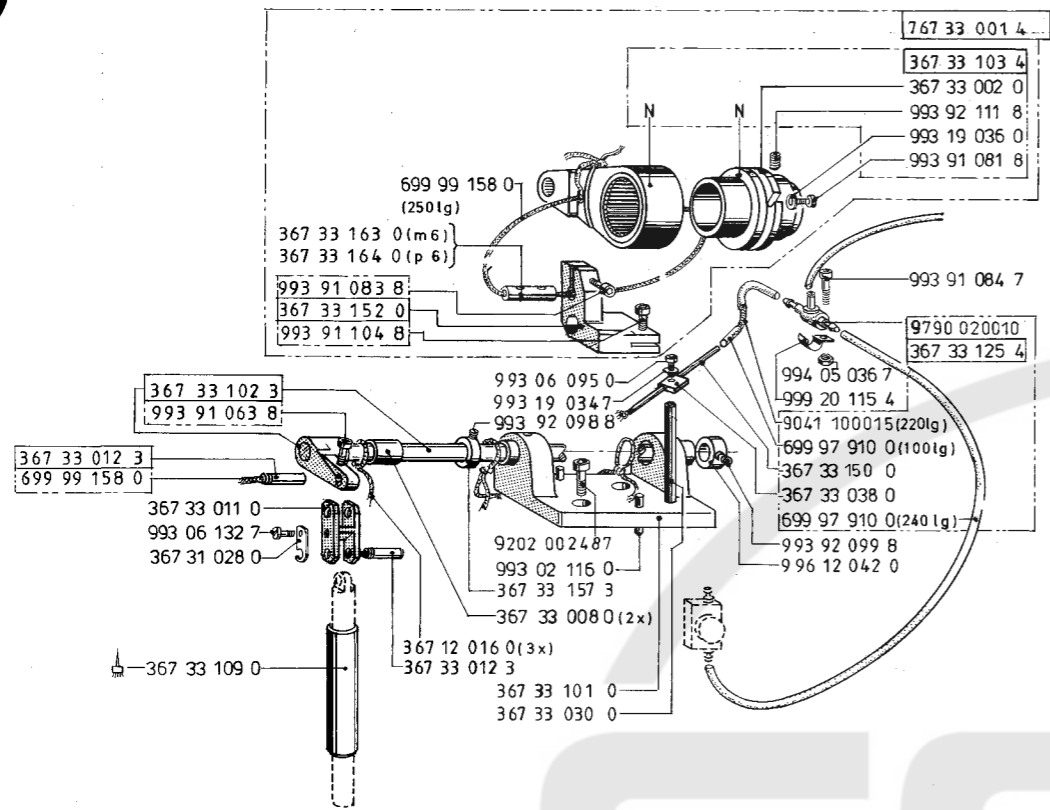

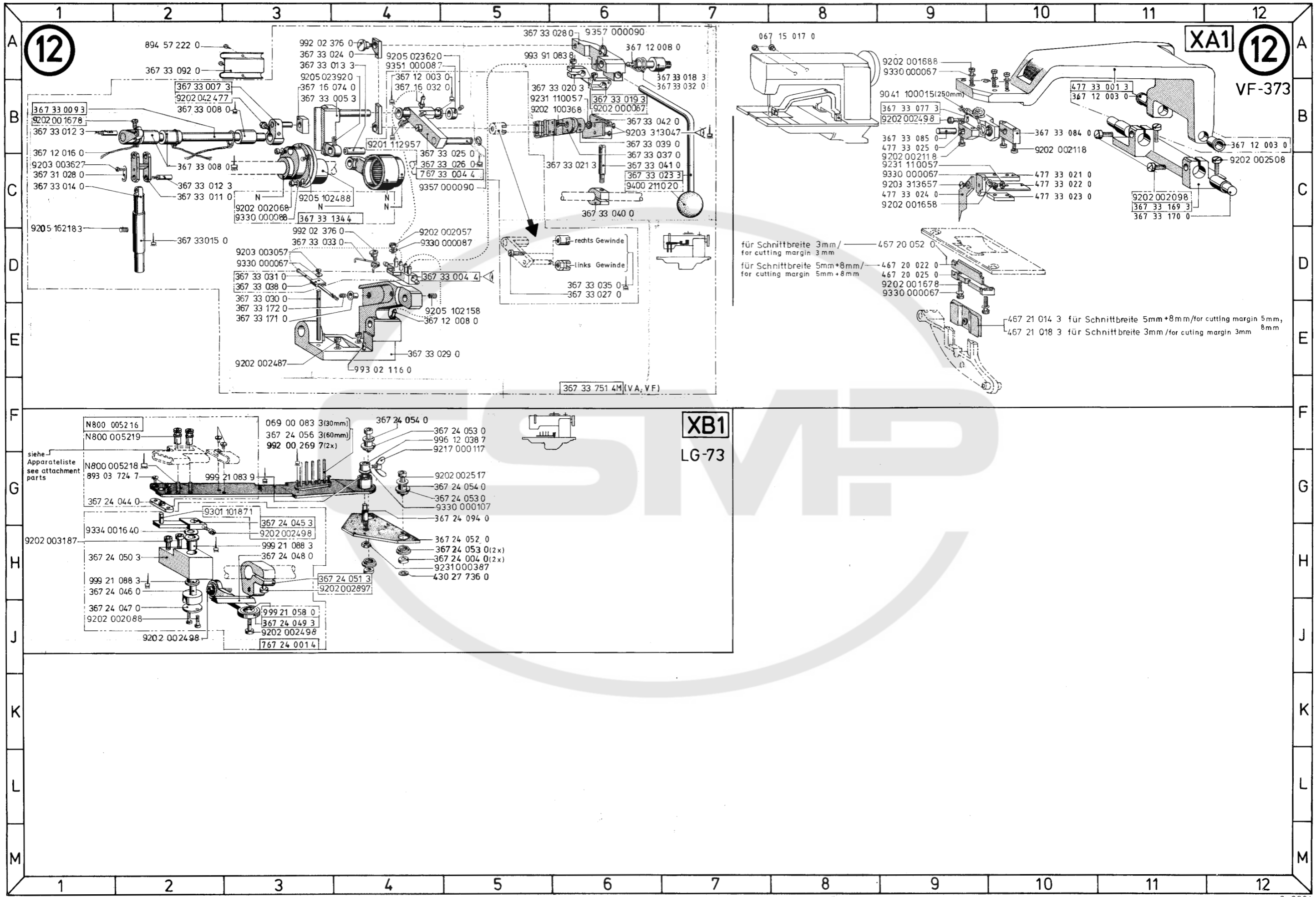

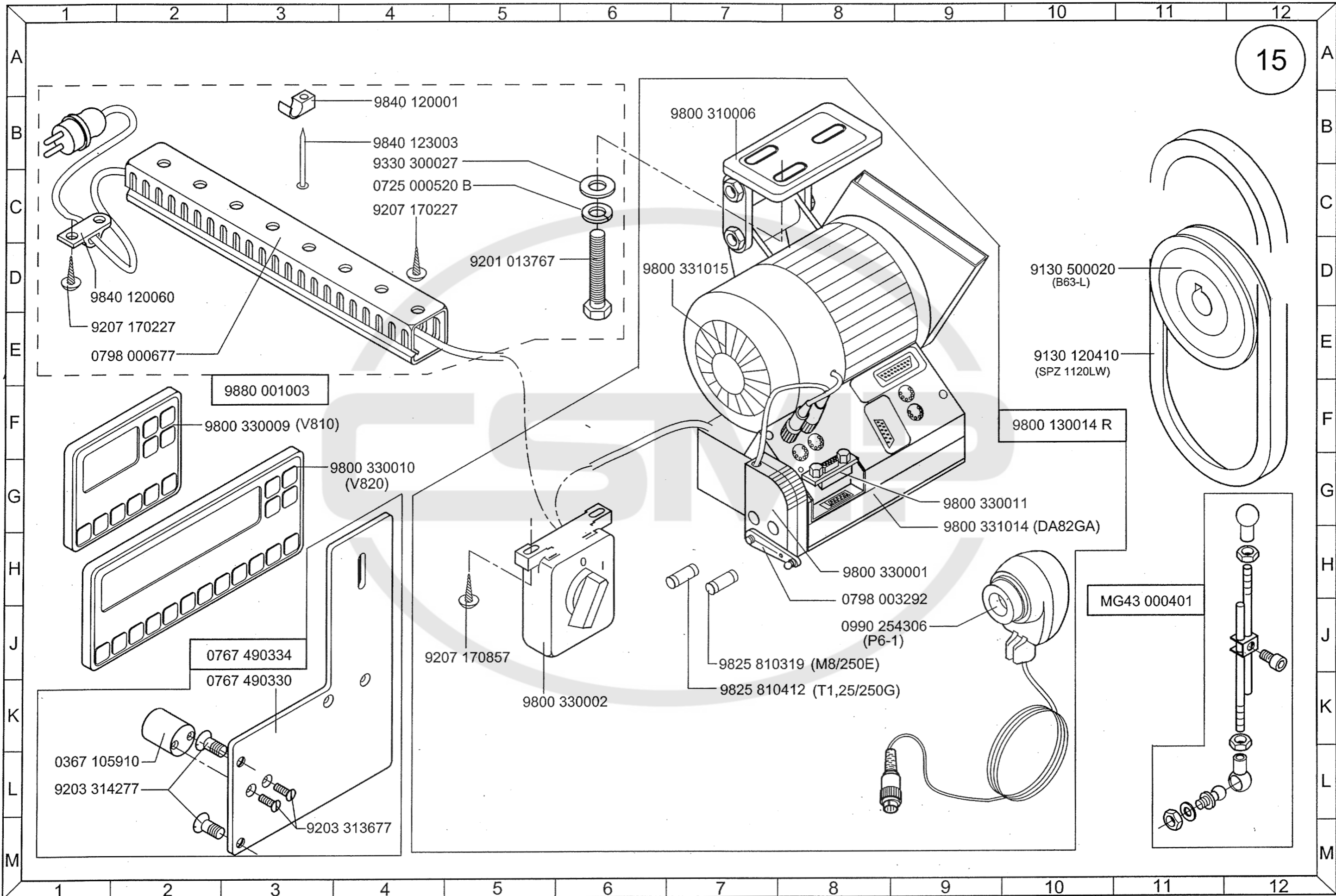

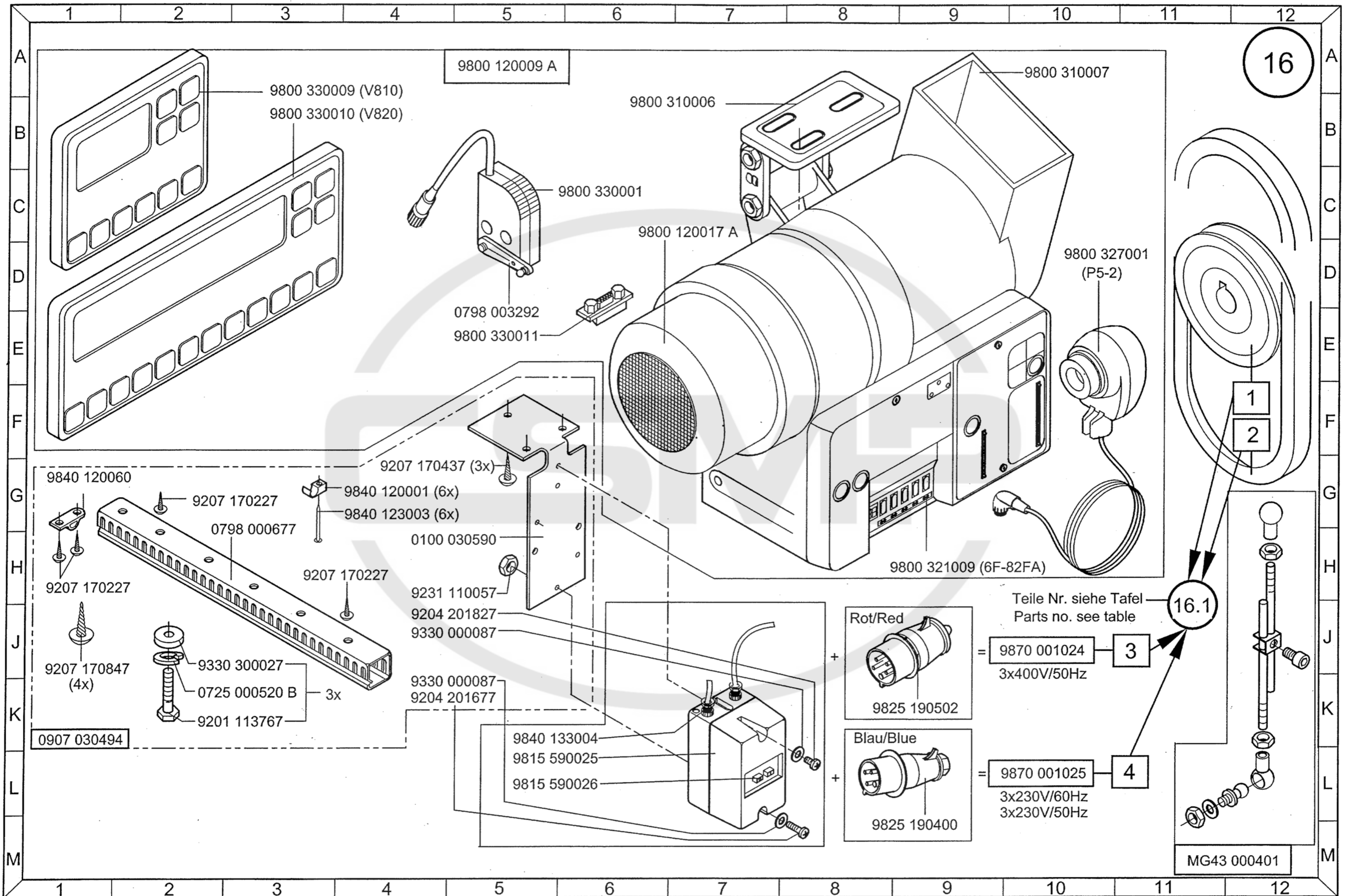

Scale 50 %

Ausgabe/Edition 02.2007

Siehe auch Tafel
See table

16

Antriebspaket Drive package	1	2	3	4
9889 076730 1	9130 500060 (B80-L)	9130 120410 (SPZ 1120LW)	9870 001024	—
9889 076730 2	9130 500060 (B80-L)	9130 120410 (SPZ 1120LW)	—	9870 001025
9889 076730 3	9130 500030 (B67-L)	9130 104200 (10x1080)	—	9870 001025
9889 076731 1	9130 500070 (B85-L)	9130 120410 (SPZ 1120LW)	9870 001024	—
9889 076731 2	9130 500070 (B85-L)	9130 120410 (SPZ 1120LW)	—	9870 001025
9889 076731 3	9130 500040 (B71-L)	9130 104200 (10x1080)	—	9870 001025
9889 076732 1	9130 500080 (B90-L)	0990 120093 (SPZX1162LW)	9870 001024	—
9889 076732 2	9130 500080 (B90-L)	0990 120093 (SPZX1162LW)	—	9870 001025
9889 076732 3	9130 500050 (B75-L)	0990 120093 (SPZX1162LW)	—	9870 001025
9889 076733 1	9130 500100 (B100-L)	0990 120094 (SPZX1187LW)	9870 001024	—
9889 076733 2	9130 500100 (B100-L)	0990 120094 (SPZX1187LW)	—	9870 001025
9889 076733 3	9130 500060 (B80-L)	9130 120410 (SPZ 1120LW)	—	9870 001025

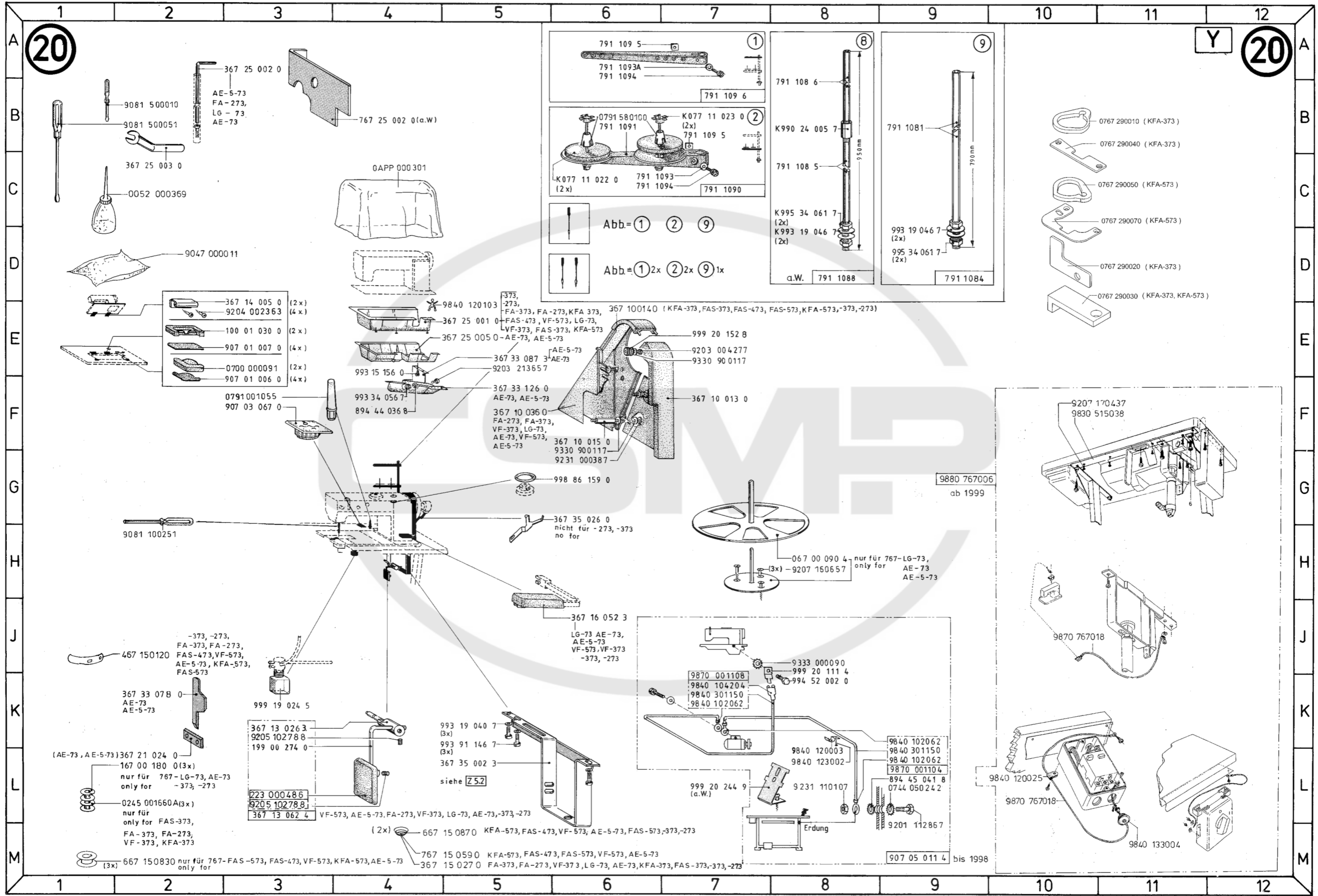

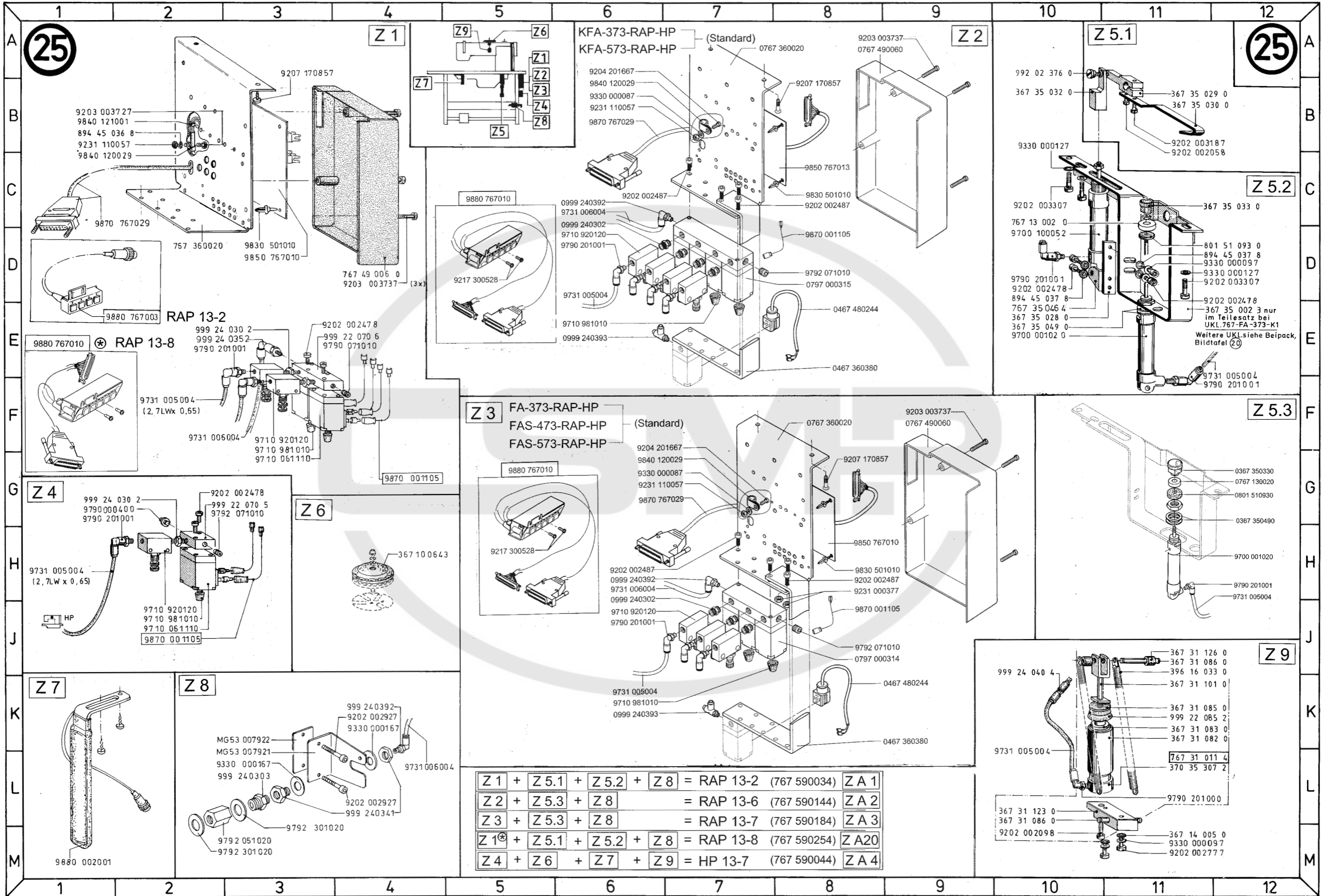

Z 1 + Z 5.1 + Z 5.2 + Z 8	= RAP 13-2 (767 590034)	Z A 1
Z 2 + Z 5.3 + Z 8	= RAP 13-6 (767 590144)	Z A 2
Z 3 + Z 5.3 + Z 8	= RAP 13-7 (767 590184)	Z A 3
Z 1 + Z 5.1 + Z 5.2 + Z 8	= RAP 13-8 (767 590254)	Z A 20
Z 4 + Z 6 + Z 7 + Z 9	= HP 13-7 (767 590044)	Z A 4

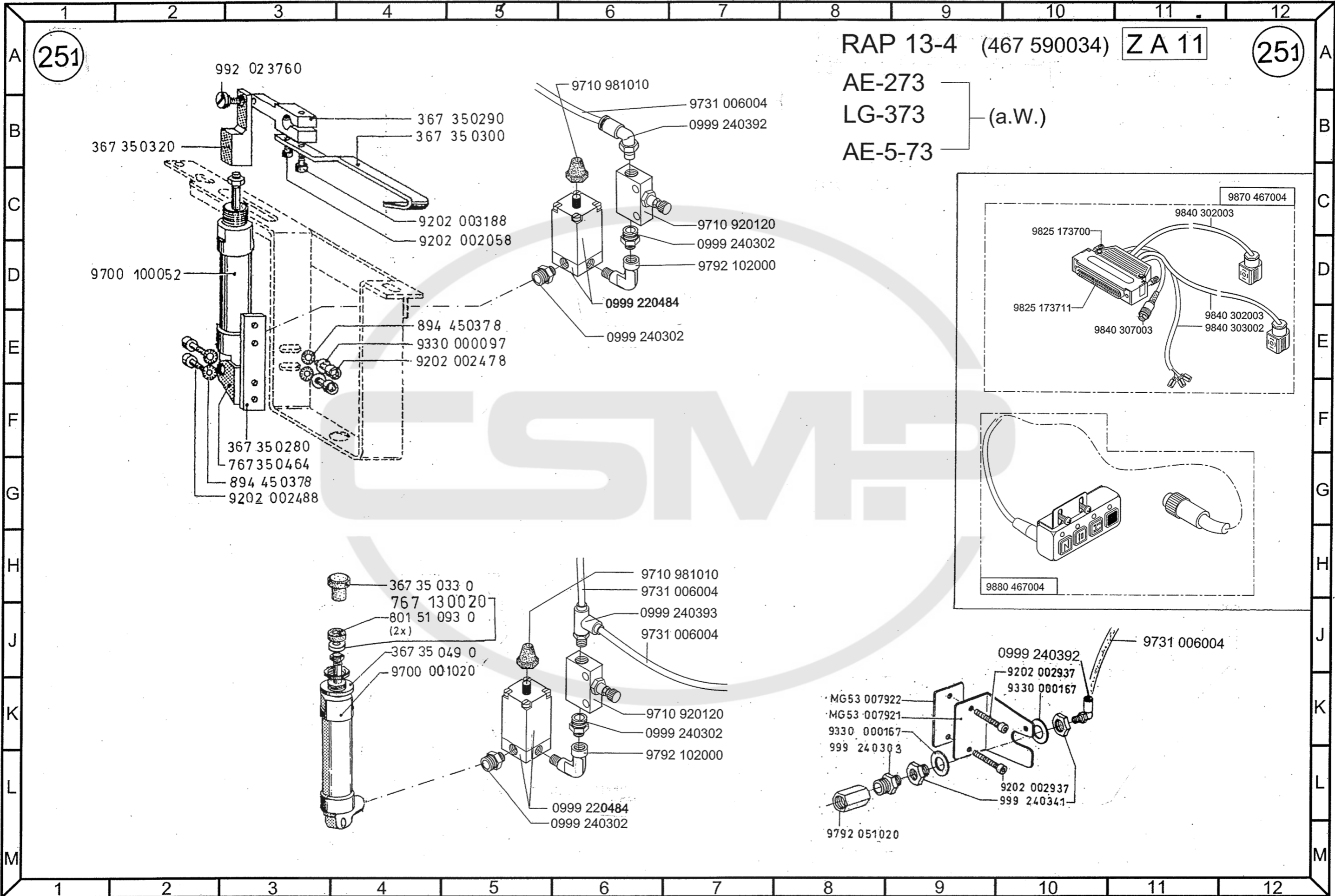

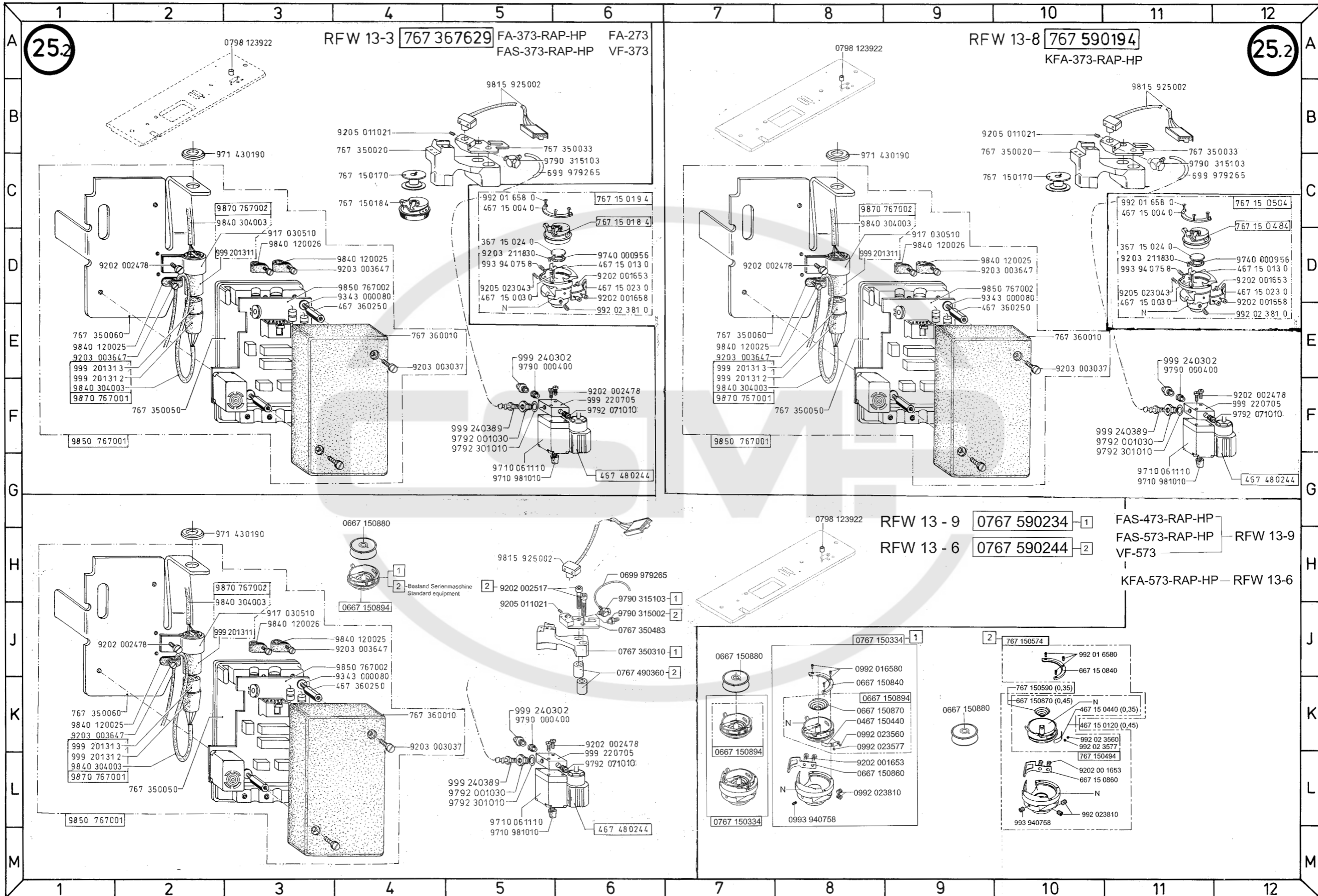

25.2

25.2

RFW 13-3 **767 367629** FA-373-RAP-HP FA-273
FAS-373-RAP-HP VF-373

RFW 13-8 **767 590194** KFA-373-RAP-HP

RFW 13 - 9 **0767 590234** 1

RFW 13 - 6 **0767 590244** 2

FAS-473-RAP-HP
FAS-573-RAP-HP — RFW 13-9
VF-573
KFA-573-RAP-HP — RFW 13-6

1
2 — Bestand Serienmaschine
Standard equipment

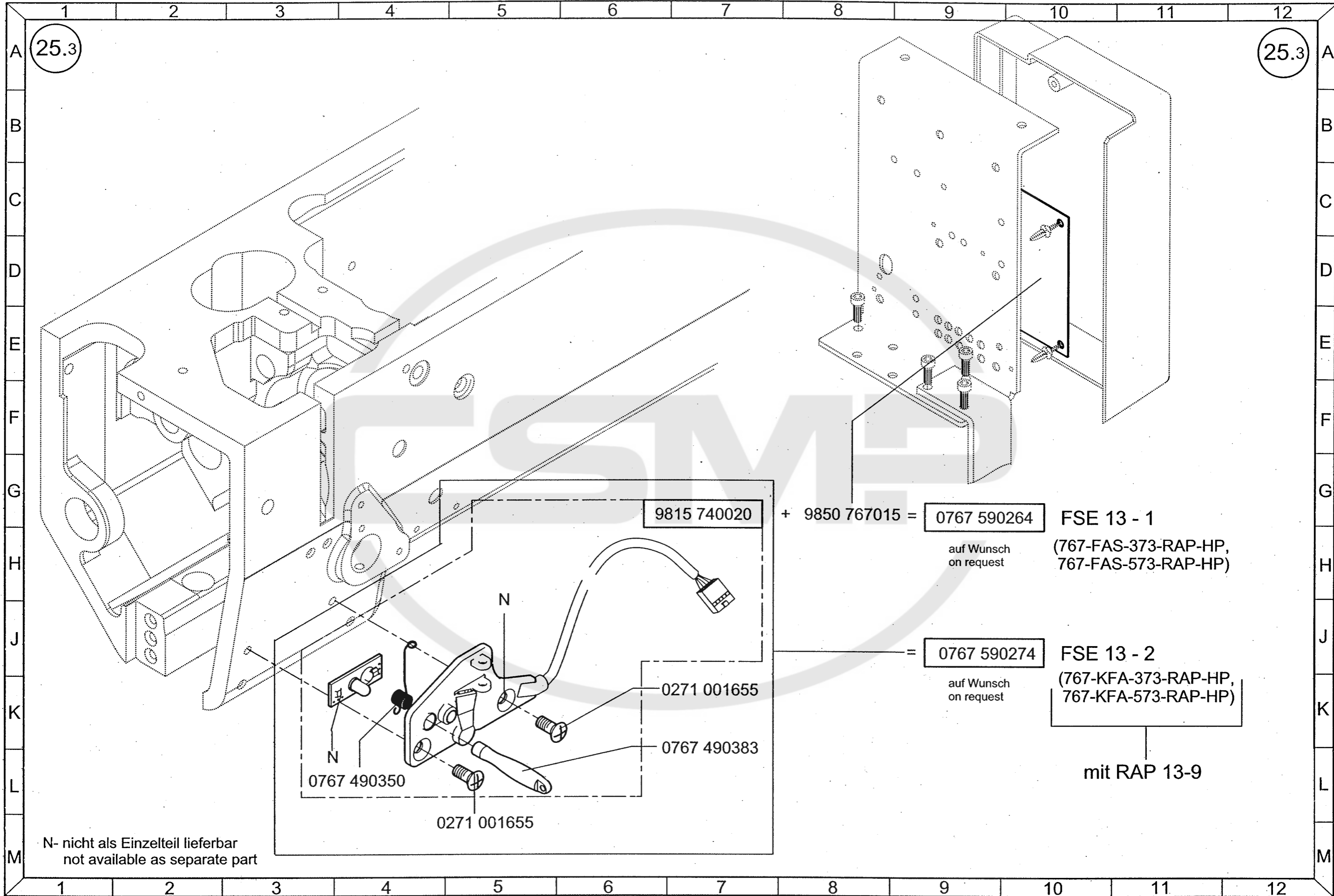

25.3

25.3

N- nicht als Einzelteil lieferbar
not available as separate part

9815 740020

+ 9850 767015 =

0767 590264

FSE 13 - 1

(767-FAS-373-RAP-HP,
767-FAS-573-RAP-HP)

auf Wunsch
on request

= 0767 590274

FSE 13 - 2

(767-KFA-373-RAP-HP,
767-KFA-573-RAP-HP)

auf Wunsch
on request

mit RAP 13-9

0767 490350

0271 001655

0767 490383

0271 001655

26

ZA6

ZA7

26

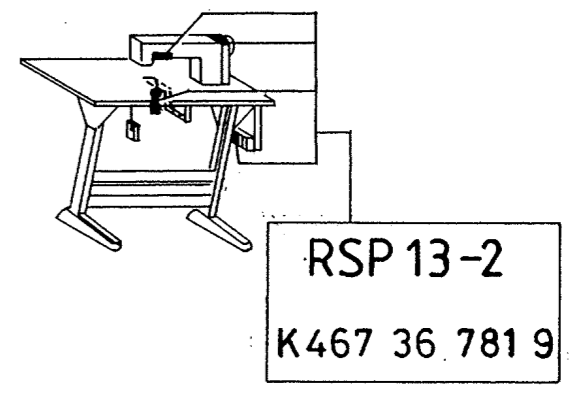
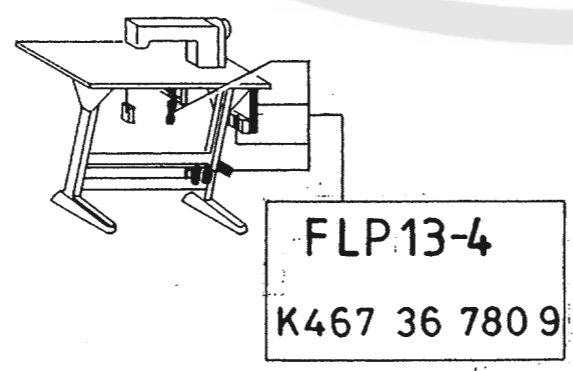
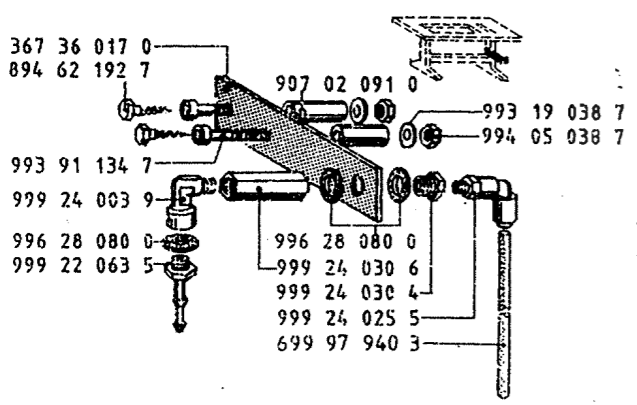
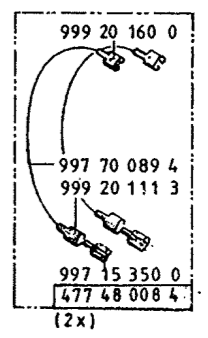
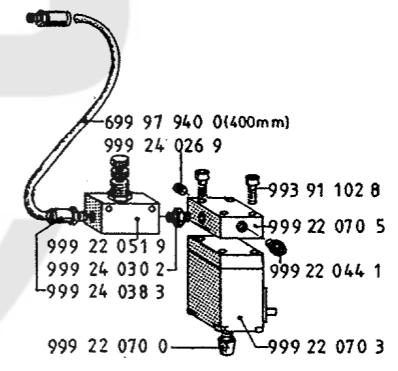
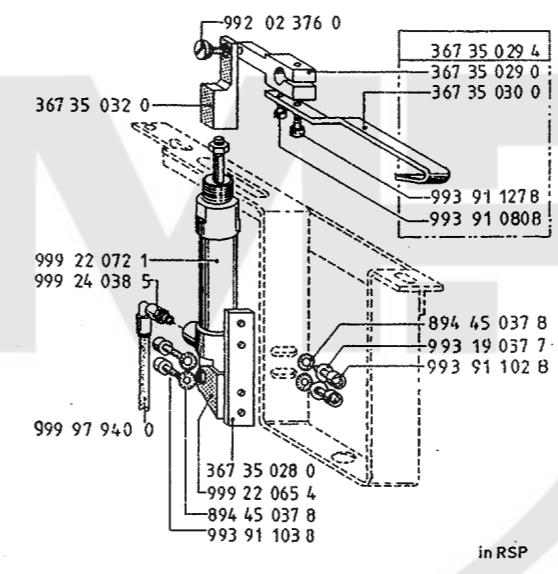
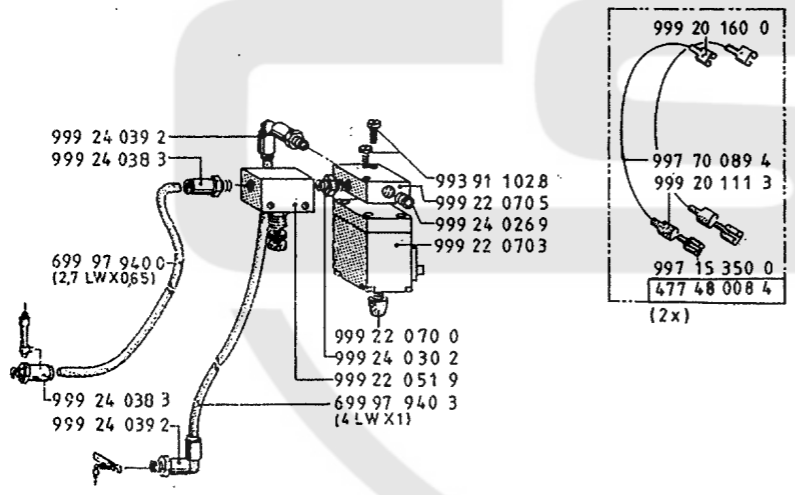
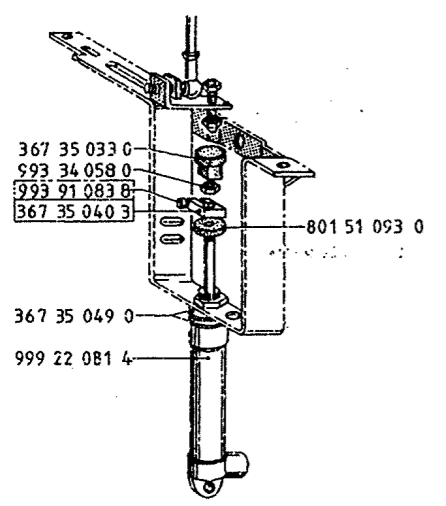
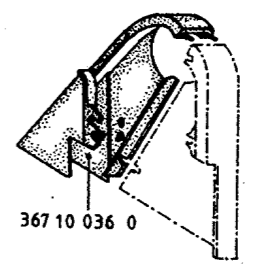
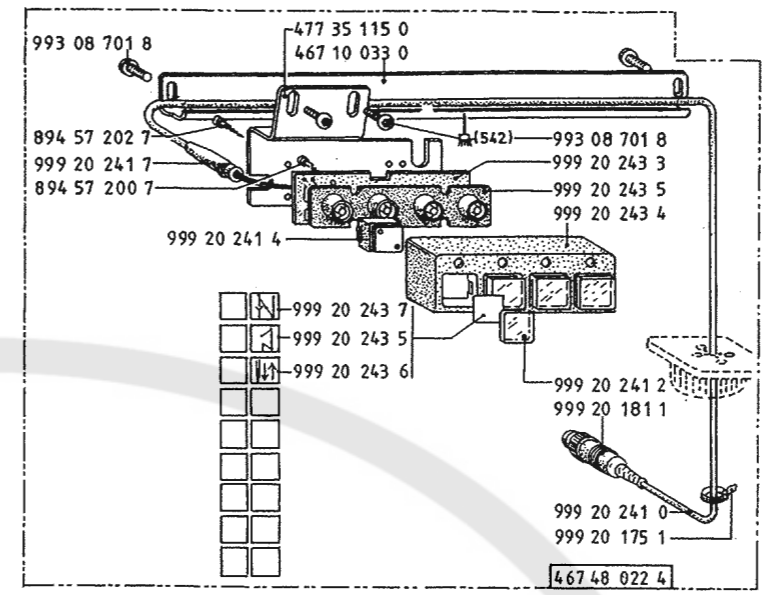
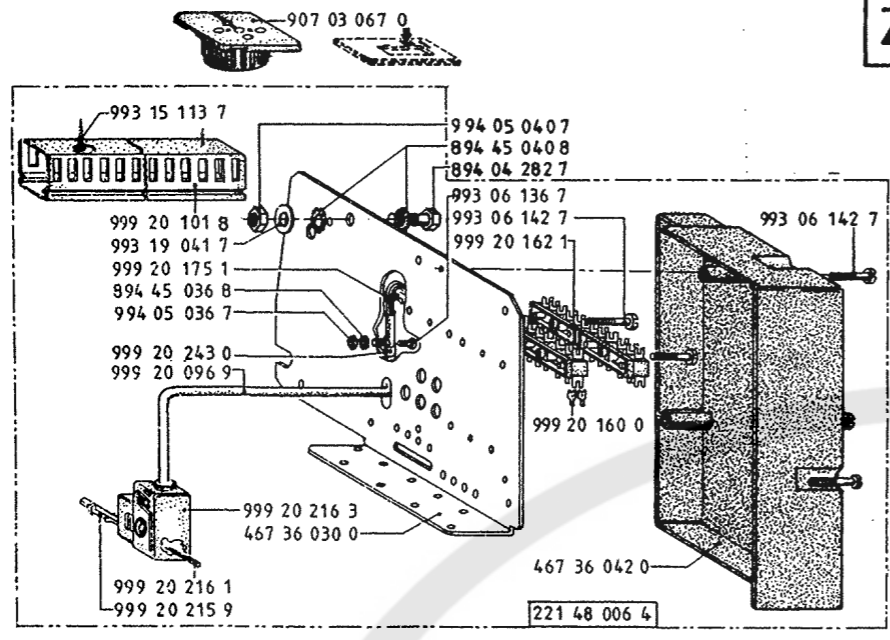

A3, D2, F5, H5, Z10

A3, F7, G3, H17, J1

27

ZA8

siehe Tafel
27.1

ZA9

27

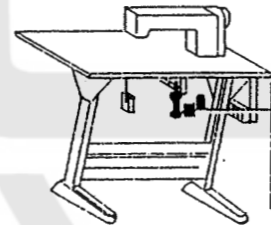
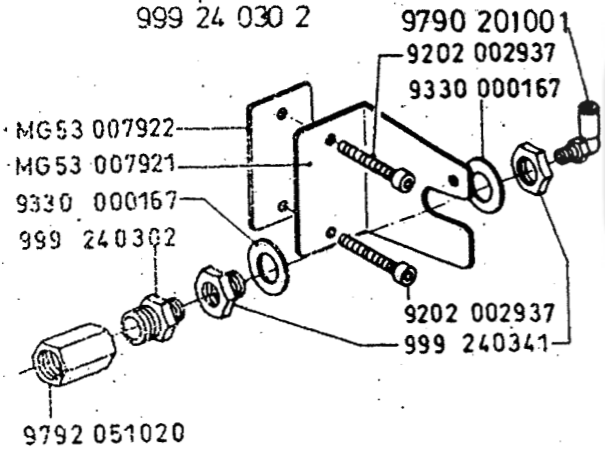
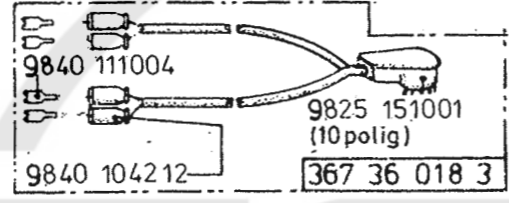
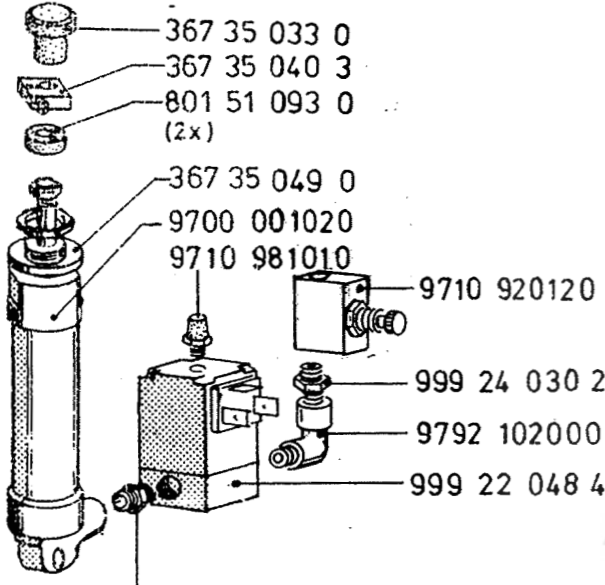

FLP13-2
K367 36 764 9
bis 12.1998

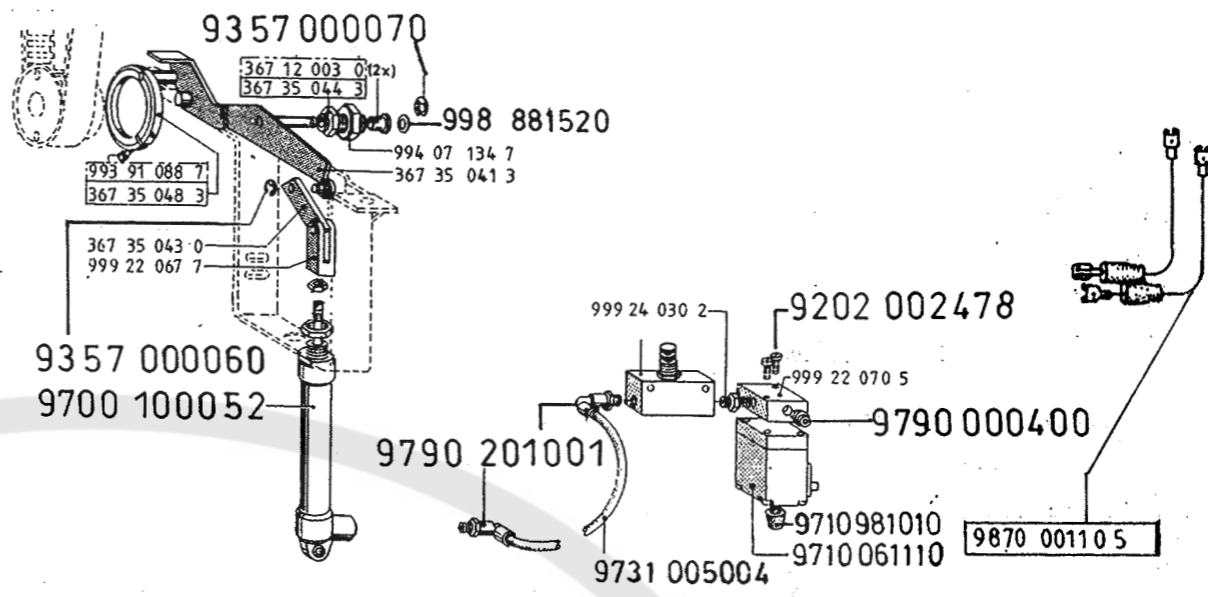

FA-373-RAP-HP FA-273
FAS-373-RAP-HP VF-373
FAS-473-RAP-HP VF-573
FAS-573-RAP-HP

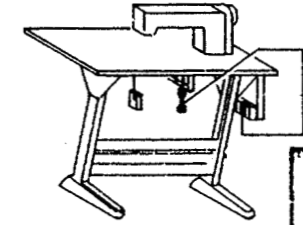

NP13-4
K467 36 779 9

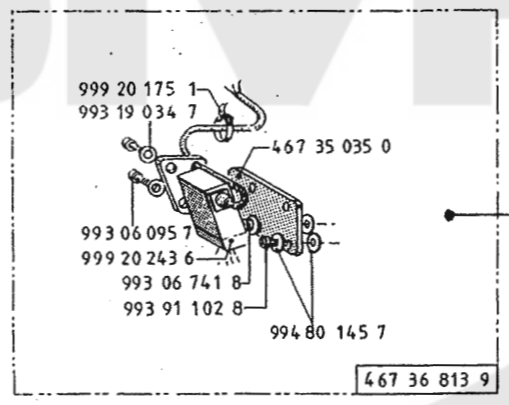

LR13-3
K467 36 813 9 ZA11

ZA10

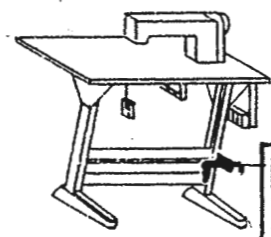
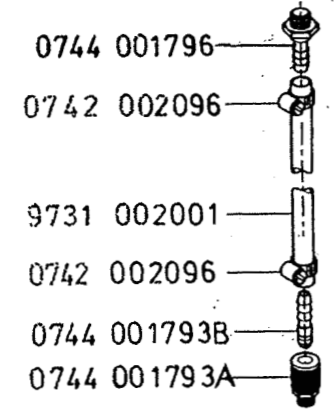

pneum.
Anschlußteile
0797 003031

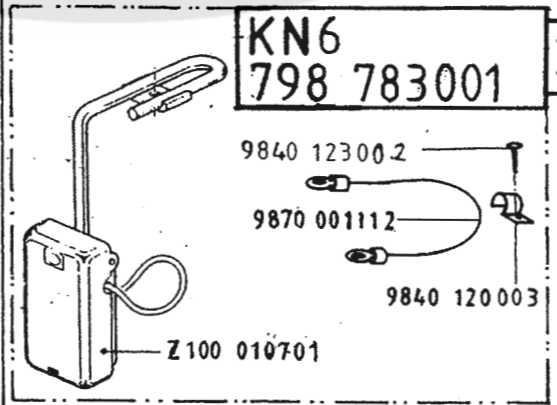

WE-6
9781 000002 ZA13

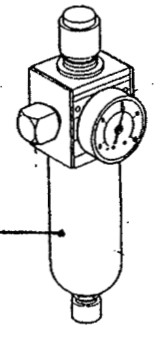

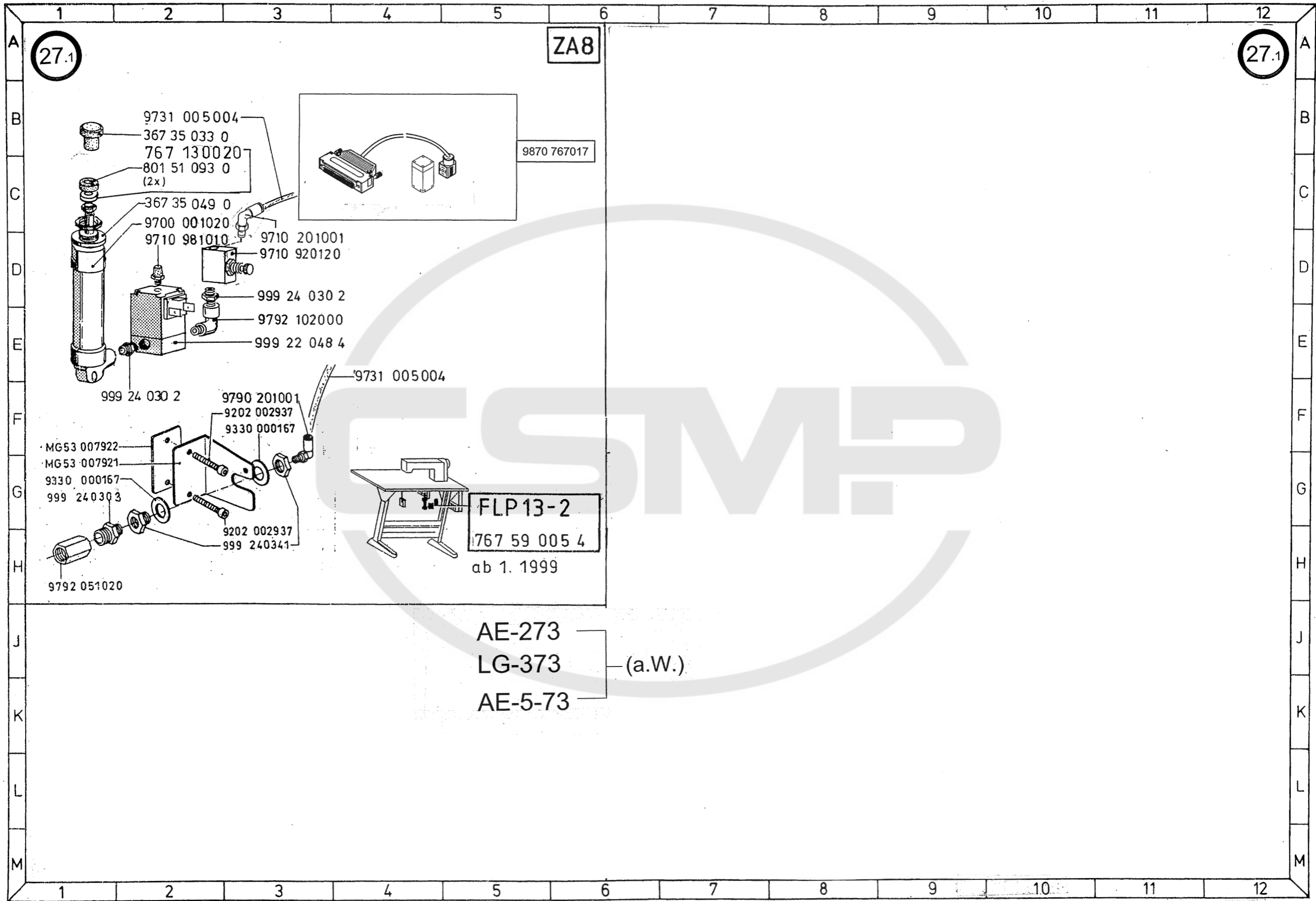

27.1

ZA8

27.1

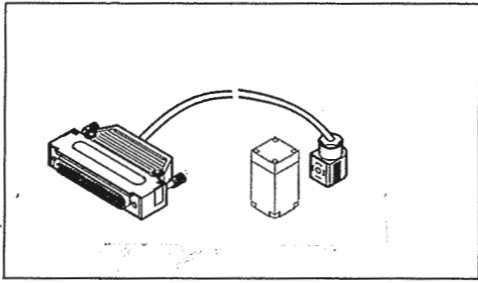
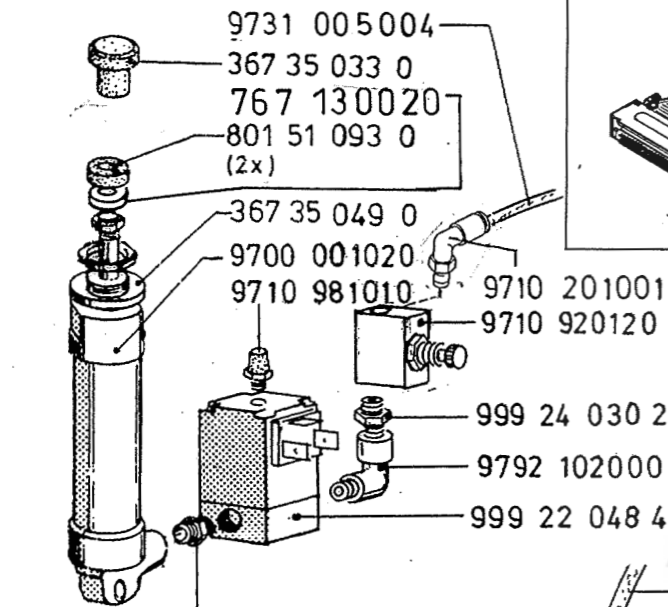

9870 767017

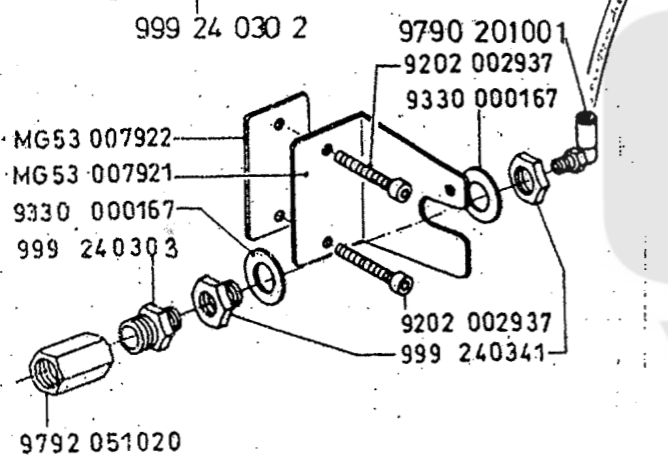

9731 005004

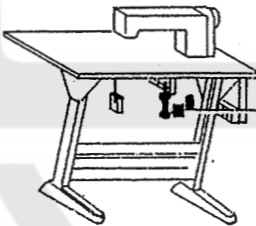

FLP13-2

767 59 005 4

ab 1. 1999

AE-273

LG-373

AE-5-73

(a.W.)

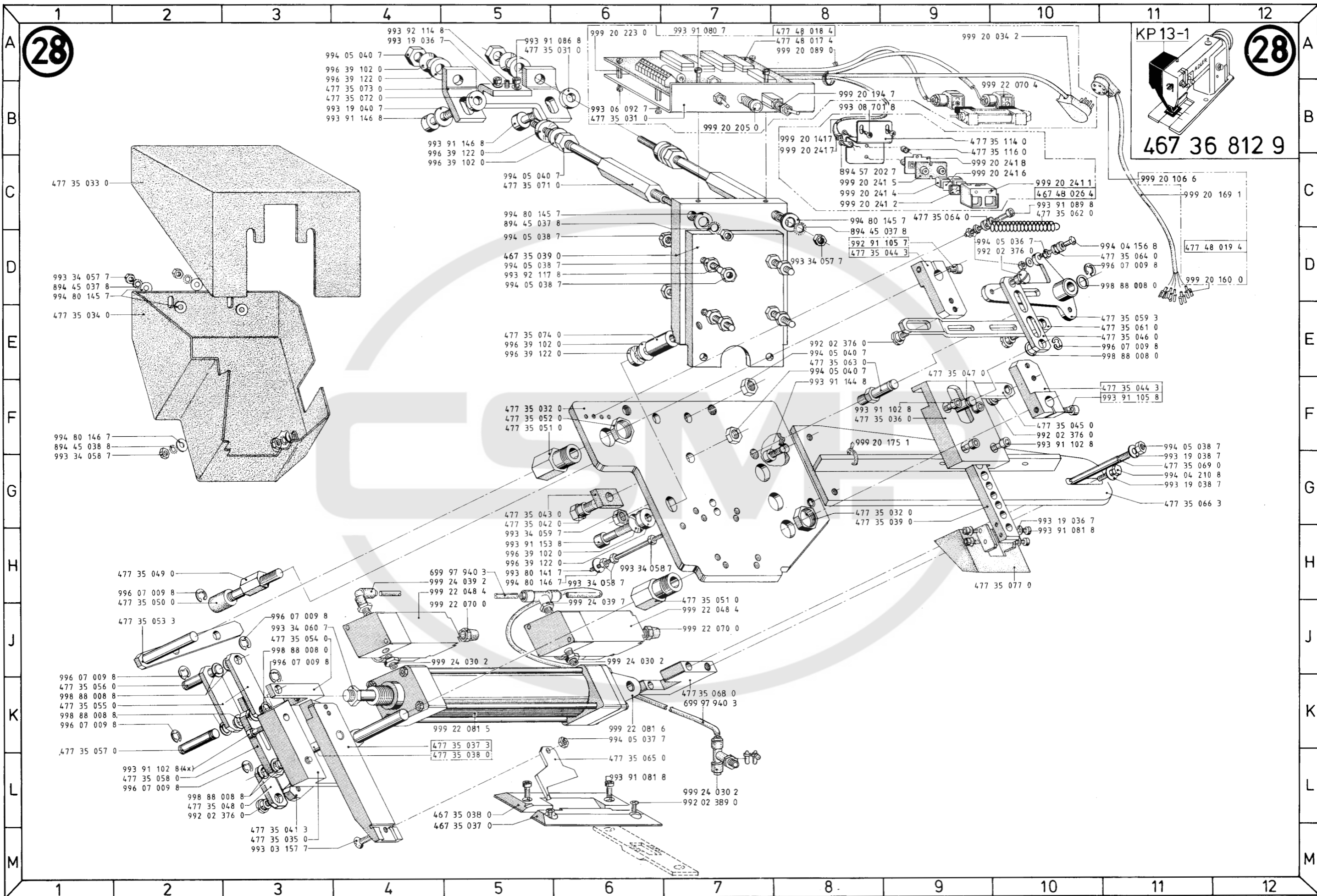

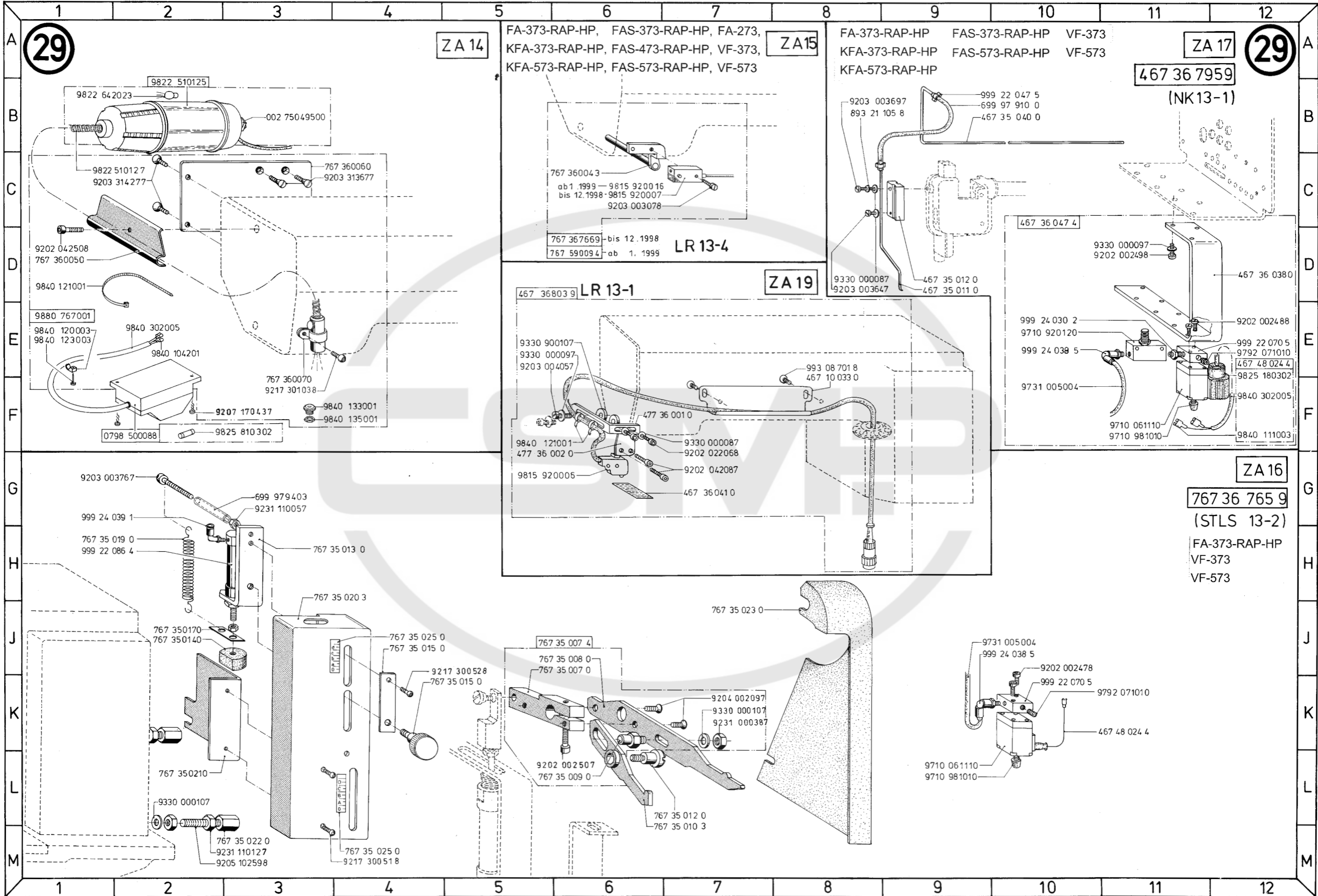

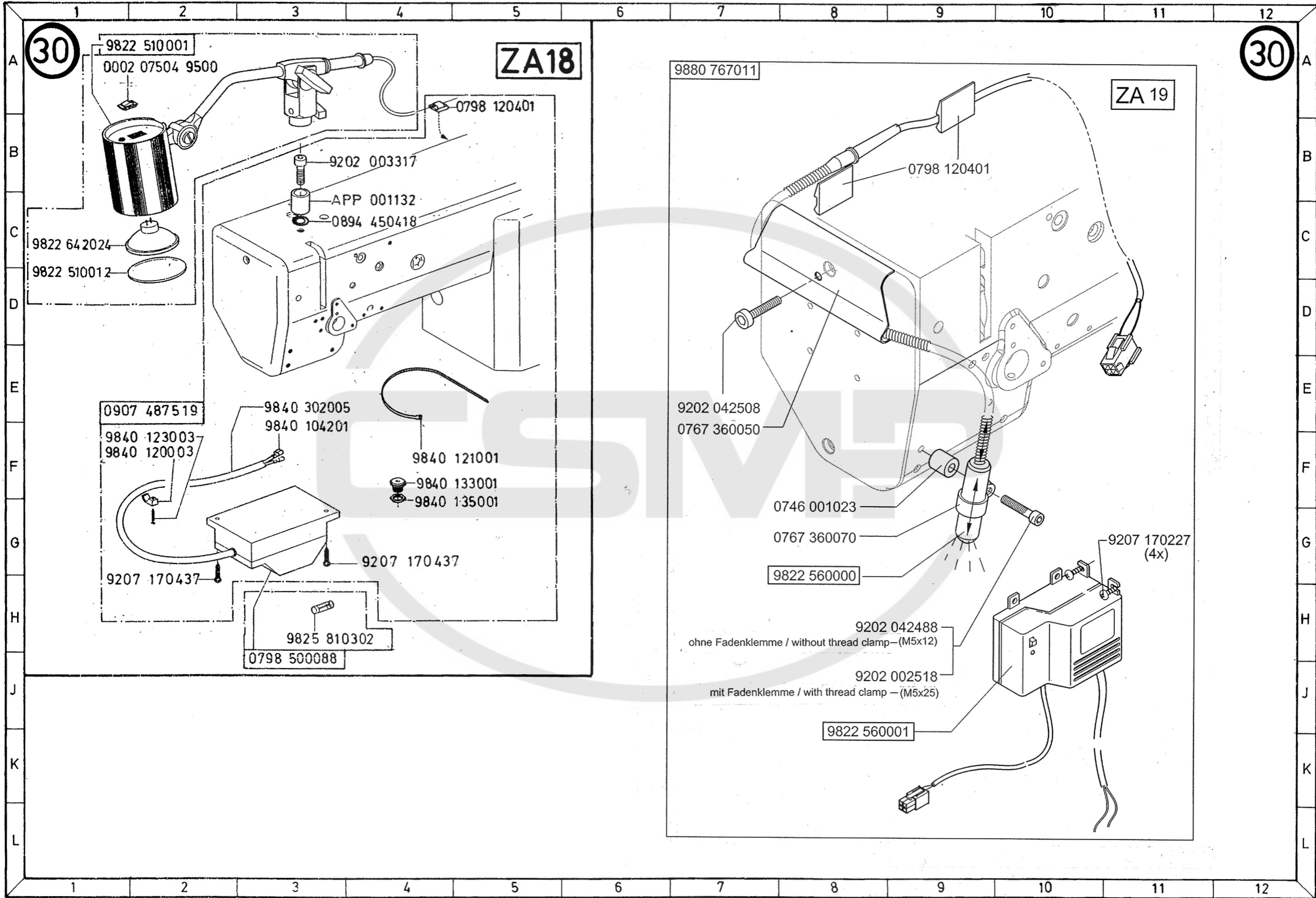

30

ZA18

30

ZA19

9822 51001

0002 07504 9500

0798 120401

9202 003317

APP 001132

0894 450418

9822 642024

9822 510012

0907 487519

9840 123003

9840 120003

9840 302005

9840 104201

9840 121001

9840 133001

9840 135001

9207 170437

9207 170437

9825 810302

0798 500088

9880 767011

0798 120401

9202 042508

0767 360050

0746 001023

0767 360070

9822 560000

9207 170227 (4x)

9202 042488
ohne Fadenklemme / without thread clamp - (M5x12)

9202 002518
mit Fadenklemme / with thread clamp - (M5x25)

9822 560001

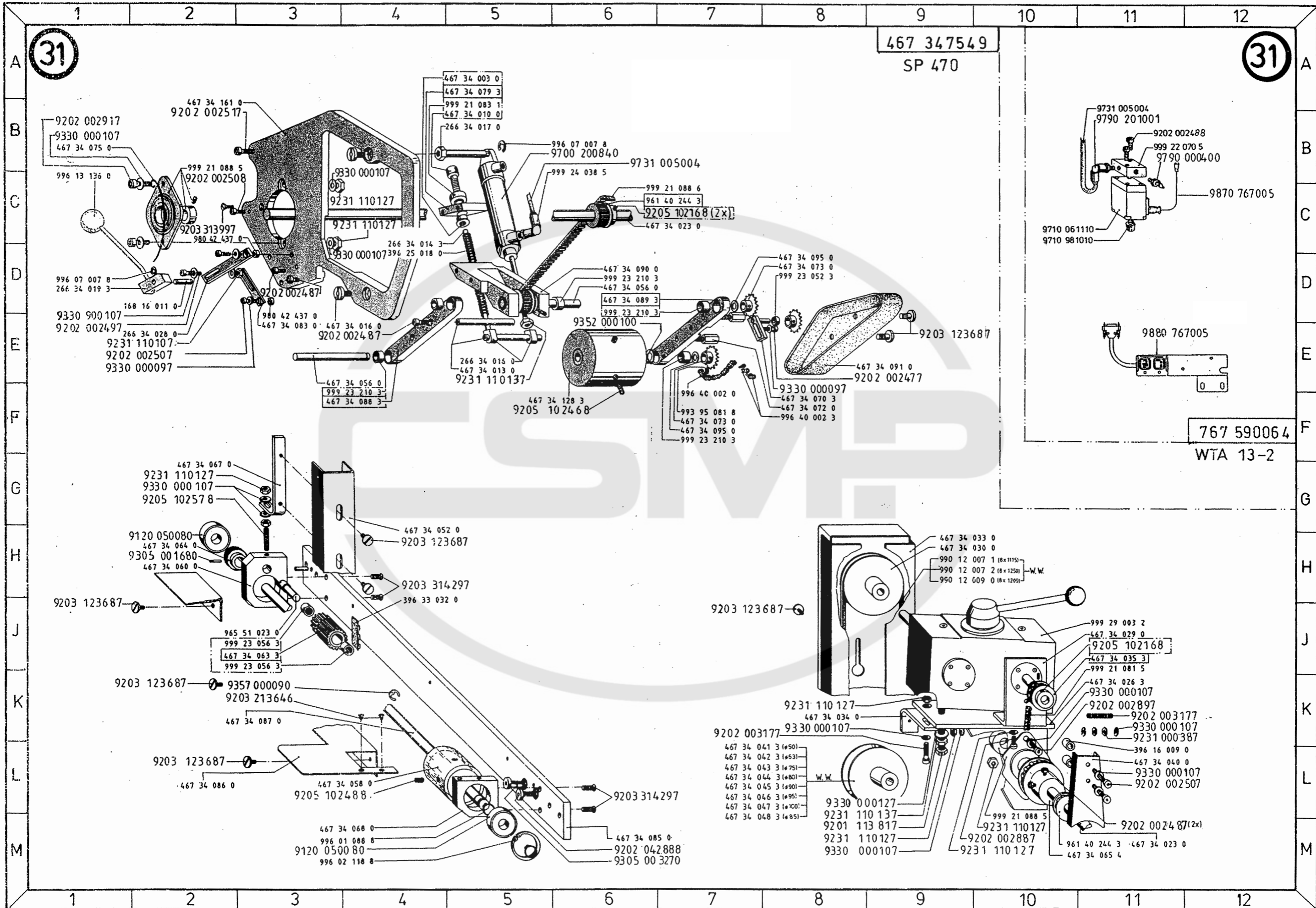

Teile-Nr./Part-No.	Benennung/Des.	Tafel/Table	Teile-Nr./Part-No.	Benennung/Des.	Tafel/Table
APP 001132	Haltestueck	30C4	0196 001890	Druckfeder	10.1C5, 10B11, 10H11
MG41 004073	Spanpl. Schr.	30H2, 30G4, 29F3	0199 002740	Stange	20K3
MG43 000401	Gestaenge K	15H11, 16H11	0216 000052	Gew. Stift	1C8, 1F8, 2C6, 2C9
MG53 007921	Winkel	25.1K827.1G1	0221 110150	Scheibe	3B1, 3B7, 10B7, 10G11, 10.1B5
MG53 007922	Lasche	25.1K8, 27.1F1	0221 110154	Vorspannung K	10B7, 10G9, 10.1B3
N800 005214	Traegerblech K	11B8	0221 110160	Buchse	3B1, 3B8, 10B7, 10G11, 10.1B5
N800 005216	Traegerblech K	12F1	0221 480064	Verteiler, kpl.	26E5
MG53 007921	Winkel	25K3, 27G1	0223 000486	Knieplatte K	20L8
MG53 007922	Lasche	25K3, 27F1	0238 001504	Zyl. Stift	3C10
N800 005218	Stiftschr.	12G1	0245 001660 A	Spule	7J11, 8E12, 20L2, 7I6, 7J11, 8E12, 8.2D12
N800 005219	Raendelmutter	12F1	0246 002566	Lippenring	1.1J3, 1.1J7, 1.1L1, 1M6
S080 953287	Einsatz	1.1H1	0266 340143	Druckstange V	31D4
S315 262085	Kegelfeder	8.1E9, 8.2E12, 20M5	0266 340160	Zugstange	31E5
Z100 010701	Knieschalter	27M7	0266 340170	Bolzen	31B5
0002 007504 9500	Wippschalter	29B3, 30A2	0266 340193	Luefterhebel	31D1
0016 004010	Filzscheibe	3C3, 3C12, 3D7	0266 340280	Lasche	31E2
0037 001280	Fadensp. Scheibe	3B1, 3B8, 10B7, 10.1A5	0268 110050	Fadensp. Bolzen	3C11
0052 000369	Oelkanne	20C2	0271 000238	Skalaknopf	3D12
0053 000350	Scheibe	1D6, 1.1D6, 1J11	0271 001639	Gew. Stift m. Zapf.	1.1E12
0061 001050	Stegscheibe	3C3, 3C12, 3D7	0271 001655	Li.Senkschr.	25.3K7, 25.3M5
0067 000904	Bandrollenhalter	20H8	0291 000159	Fadenfuehrung	2K1
0067 001560	Sperrfeder	1D3, 1.1D4	0296 000510	Scheibe	6A2, 6A3
0067 001770	Druckfeder	6G11, 6L11	0296 001250	Dichtscheibe	1D5, 1.1D5
0067 002470	Haken	5E4, 5E10	0296 001543	Lueftungsrohr V	1D3, 1.1D3, 9E2, 9E7, 9L7
0067 150170	Stopfen	11F8, 12A8	0296 002090	Spannr. Achse	1D6, 1.1D6
0067 160490	Bolzen	1K5	0296 110030	Spannungsfeder	10L1, 10.2K6
0067 320150	Druckfeder	10D9, 10.1G3, 10L9	0296 150013	Lager V	1C6, 1.1C6
0067 351680	Bolzen	8E1, 8E3, 8F5, 8.2H9, 8.4J9	0296 250010	Haube	20C4
0068 000280	Fad.anzugsfeder	3E6	0367 100040	Handrad	2D1
0068 000660	Druckfeder	8E1	0367 100044	Handrad	2C1
0068 001830	Feder	5L8, 5F3, 5F9	0367 100050	Flansch	2E2
0068 004910	Fad.anzugsfeder	3E3	0367 100063	Lagerhuelse K, hi	1B11, 1E12
0068 004930	Fadenanz. Feder	3E4	0367 100080	Buchse	10D9
0068 005330	Scheibe	3H2, 3J6	0367 100090	Bolzen	10C9
0068 005350	Fadenf. Bolzen	3H2, 3J6	0367 100130	Riemenschutz	20F7
0068 111030	Druckfeder	3H2, 3J6	0367 100150	Bolzen	20F6
0069 000833	Bandeinf. Platte	11A9, 12F3	0367 100170	Nippel	9C2, 9C6, 9L6
0069 120020	Stopfen	4M1, 5M2	0367 100180	Schauglas	9H8
0077 110220	Auflage	20C6	0367 100190	Rohr	9K6
0077 110230	Zentrierstueck	20B7	0367 100240	Schutzblech	9D3, 9D7, 9K8
0081 001390	Scheibe	11A8	0367 100260	Oelrohr	9B1, 9B5, 9H5
0081 003080	Druckplatte	11J3	0367 100284	Armwelle	1B9
0081 004910	Druckstueck	11J3	0367 100300	Druckfeder	9D1, 9D5, 9K5
0088 002320	Huelse	3H2, 3J6	0367 100353	Lagerhuelse	1C10, 1F10
0099 004800	Kegelfeder (1,4D)	3C12, 3D3, 3E7	0367 100360	Riemenschutz hi	20F5, 26C10
0099 004910	Kegelst.Fed.(1,1D)	3C12, 3D3, 3E7, 3E10	0367 100390	Federbuegel	9C2, 9C6, 9J6
0099 004930	Deckscheibe	3E3	0367 100420	Handrad	2B2
0100 010300	Auflage	20E3	0367 100424	Handrad	2B2
0100 030590	Winkel	16H5	0367 100430	Riemenscheibe	2B1
0167 001800	Spule (schwarz m.Raendel)	6.1B3, 7.1J3, 10A11, 20L2	0367 100480	Bolzen	10J8, 10.1D2
0167 005050	Abfallblech	11J9	0367 100490	Schutzblech	10J8, 10.1D2
0167 150270	Spule	7I6, 7J11, 8H2, 8E12, 10G11, 20L2	0367 100510	Abdeckung	10J8, 10.1D2
0167 330020	Messer	11L2	0367 105910	Bolzen	15L1
0167 331030	Druckfeder	10C9	0367 100593	Oelrohr	9B1, 9B5
0168 160110	Bolzen	31D2	0367 100610	Oelschlauch	9B3, 9B8
0170 100030	Schutzstopfen	10C8, 10J8, 10.1E2			

Teile-Nr./Part-No.	Benennung/Des.	Tafel/Table	Teile-Nr./Part-No.	Benennung/Des.	Tafel/Table
0367 100633	Einst. Scheibe	10H8	0367 120050	Gleitfuehrung	1J1
0367 100643	Einst. Scheibe V	10H7, 10.1C5, 25H4	0367 120080	Nippel	1J1, 1K1, 7E11,8F8, 8.2G6, 12A6, 12E4
0367 110010	Oese	2B5, 2B8, 2G2	0367 120093	Klemmkloben	1J3, 1J4
0367 110033	Fadenh. Lenker V	2A5, 2A7, 2F2	0367 120100	Oelscheibe	1K2
0367 110040	Lenkerbolzen	2B4, 2B7, 2G1	0367 120110	Gew. Bolzen	2C6, 2C9, 2H3
0367 110050	Dichtscheibe	2B5, 2B8, 2B12,2F3	0367 120193	Nadelstg. Gelenk	2H2
0367 110070	Buchse	2B5, 2B8, 2B12,2F3	0367 120260	Fadenoese	2K2, 2M2, 30C2, 30C5
0367 110100	Zapfen	5E8, 5E9, 5J7	0367 120270	Platte	1K1, 1L2
0367 110110	Spannungsplatte	3C7, 3D3	0367 120284	Nadelstg.Schwinge	1L2
0367 110120	Bolzen	3C2, 3D7	0367 120800	Nippel	8.4H5
0367 110130	Huelse	3D1, 3D5	0367 130130	Bolzen	5B2, 5B8, 5G7
0367 110140	Scheibe	3D7	0367 130140	Fuehr. Buchse	5F3, 5F9, 5L8
0367 110150	Haken	3C3, 3C7	0367 130153	Stellring K	1J8, 1J11, 5D3, 5D9, 5J8
0367 110160	Buchse	3E1, 3E5	0367 130170	Buchse	1J12,5C2, 5C4,5C5, 5C10, 5D8, 5H8, 5H10, 5J7, 5L9,1K8
0367 110164	Fadenfuehrung	3E3	0367 130180	Buchse	5D1, 5D7, 5J6
0367 110170	Bolzen	3F1, 3F5	0367 130240	Luefterhebel	5B12, 5G11
0367 110183	Deckscheibe V	3E11, 3F2, 3G7	0367 130253	Luefterkloben K	5B5; 5B10, 5H10
0367 110203	Ausloesehebel	10E2, 10.2L1	0367 130263	Kloben	20K3
0367 110220	Einst. Mutter	10E4, 10.2L4	0367 130273	Spindel V	5B2, 5B8, 5G7
0367 110240	Druckknopf	3C3, 3C7	0367 130290	Arretierbolzen	5F3, 5F9, 5M8
0367 110254	Fadenfuehrung	3E6	0367 130340	Gleitlager	5D1, 5D3, 5D7, 5D9, 5J6
0367 110270	Zugstange	10D2, 10.2K1	0367 130440	Zugfeder	5E4, 5E10, 5K9
0367 110280	Magnettraeger	10.2J11	0367 130600	Druckfeder	5C1, 5C7, 5H6
0367 110290	Buchse	3E11, 3F2, 3G7	0367 130624	Kniehebel	20L3
0367 110300	Koerper	3G2, 3H1, 3H5, 3J5	0367 130633	Fuehrung	4E1, 4E5, 4E9
0367 110304	Fadenf. Koerper	3H1, 3J5, 3J7	0367 130640	Gleitstein	4D1, 4D6
0367 110310	Fadenf. Blech	3G2, 3H5	0367 130680	Oeldocht	4E2, 4E6
0367 110333	Haken	3G2, 3H6	0367 130710	Huelse	5C1, 5C7, 5H6
0367 110334	Fadenfuehrung	3G2, 3H5, 3H7	0367 130720	Stange	5C1, 5C7, 5H6
0367 110340	Fadenanz. Rolle	3E10,3F2, 3F6, 3G6	0367 130920	Buchse	4F2, 4F6
0367 110350	Zwischenscheibe	3E10, 3F2, 3F6	0367 130960	Stange	5E5, 5E11, 5K10
0367 110360	Scheibe	3E10, 3F2, 3F7,3G6	0367 130964	Hebel K	5F12, 5F6, 5M11
0367 110370	Fadenoese	3C2, 3D5	0367 130970	Kugelbolzen	5G11, 5G5, 5M10
0367 110380	Stift	3C2, 3C5	0367 140020	Deckel	1D6, 1.1D6
0367 110390	Stift	3D6	0367 140030	Deckeldichtung	1E5, 1.1E5
0367 110423	Kloben K	10D3, 10.2J3	0367 140040	Oelanzeiger	1D6, 1.1D6
0367 110433	Hebel	5F8	0367 140050	Scharnier	20E3, 25M11
0367 110440	Feder	3E7	0367 140060	App. Schieber	2H9
0367 110460	Hebel	5F4, 5F10, 5L9	0367 140064	App. Schieber K	2F9, 2G6, 2G7,2G9, 2H9, 2G11
0367 110470	Druckfeder	10.1A5	0367 140070	Blattfeder	2H9
0367 110480	Magnettraeger	10E5, 10.2L5	0367 140090	Schieber, re	2G6, 2J4
0367 110490	Stange	10E4, 10.2L4	0367 140100	Fuss	1.1E3
0367 110510	Klemmplatte	3C9	0367 140170	Schieber	2F7, 2L7
0367 110520	Fadenh. Kurbel	2C7, 2H1	0367 140190	Schieber, li	2F8, 2L4
0367 110530	Kurbel	2C4	0367 140320	Schieber, li	2F7, 2K4
0367 110544	Fadenfuehrung	3E4	0367 142070	Schieber	2F6, 2J4
0367 110554	Fadenfuehrung	3E7	0367 142340	Schieber, re	2F7, 2K7
0367 110570	Feder	3C3, 3C7	0367 150050	Lagerbuchse	6G10, 6L10, 8.4D6, 8.5C9
0367 110580	Fadenfuehrung	3C2, 3C5	0367 150060	Scheibe	7C9
0367 110593	Hebel K	5D2, 5J7	0367 150070	Gewindestift	6F7, 6K6, 7C9
0367 110600	Haken	10L3, 10.2J8	0367 150080	Zahnrad	6F5, 6K5
0367 110610	Bolzen	10L3, 10.2K8	0367 150093	Klaue	6G5, 6L6
0367 110633	Ausloesehebel	10L1, 10.2K6	0367 150103	Klaue	6G5, 6L5
0367 110640	Kloben	10L4, 10.2J10	0367 150113	Stellring K	8.2H12
0367 120013	Nadelstg. Gelenk	2D5, 2D8, 2C10, 2C12			
0367 120023	Nadelstg. Klob. V	2D4, 2D7, 2H1			
0367 120030	Buchse	11J5, 12A4, 12B11, 12B12, 27A7			
0367 120040	Gleitstein	2D6, 2D9, 2H3			

Teile-Nr./Part-No.	Benennung/Des.	Tafel/Table	Teile-Nr./Part-No.	Benennung/Des.	Tafel/Table
0367 150120	Welle	9L11	0367 150820	Exz. Welle K	7B6, 7B10, 7.1C3, 8D5, 8D8, 8.2D8, 8.2E6, 8.4E6, 8.5D9
0367 150133	Klemmring K	8.4F7	0367 150824	Exzenterwelle	7B11, 7C6, 7.1C3, 8D5, 8D9, 8.5C7, 8.4E7
0367 150150	Zahnriemen	6E11, 6J11	0367 150830	Bolzen	6B4, 7B11, 7.1B2, 8C5, 8C9, 8.2D8, 8.4D7, 8.5C9
0367 150163	Zahnriemenrad	1B10, 1E11	0367 150840	Prisma	6B4, 7B11, 7.1C2, 8C5, 8C9, 8.2D8, 8.4E7, 8.5C9
0367 150180	Welle	9L2, 9L8	0367 150850	Feder	9K6, 9L1, 9L10, 9M6,
0367 150193	Klemmring K	7D11, 7E4, 7.1E2, 8E9, 8F3, 8.2G8, 8.4H7, 8.5E7	0367 150860	Feder	9L6
0367 150240	Deckel	6.1D2, 6.1D6, 6.1J2, 8.2E11, 25.2C5, 25.2D11,	0367 150884	Schlauch	9K7
0367 150270	Kegelst. Feder	6.1C3, 6.1C7, 6.1J3 8.2E12, 20M4, 25.2D12	0367 150894	Schlauch (2-Nad.)	9L6
0367 150280	Scheibe	1.1C9, 7B6, 7B10, 7.1B3,	0367 150900	Paszscheibe	7B6, 7B10, 7.1B3, 8B5, 8C6, 8.2C6, 8.4D6, 8.5C9
0367 150310	Greiferlager, re	7E10	0367 150910	Paszscheibe	7B6, 7B10, 7.1B3, 8C5, 8C8, 8.2D6
0367 150320	Greiferlager, li	7E6, 7.1E3	0367 150920	Halter	9K11, 9L2, 9L8, 7.1L3, 8L8, 8L11
0367 150330	Lagerdeckel	7C7, 7C9, 7.1D4, 8E5, 8E7, 8.2F5, 8.4F5, 8.5E9	0367 150930	Buchse	6F7, 6K6
0367 150343	Greiferwelle K	7D6, 7.1D3, 8E5, 8E8, 8.2F6	0367 150940	Laufrolle	6F7, 6K7
0367 150360	Bolzen	7E10, 7.1C2, 8.2G6 8D3, 8F8, 8.5D9	0367 150950	Kolben	6G7, 6L7
0367 150380	Bolzen	7C4	0367 150960	Welle	6G7, 6L7
0367 150403	Stirnrad	7F6, 7F11, 7.1F3, 8G3, 8G9, 8.2J8, 8.4K7, 8.5G7	0367 150973	Oelschlauch	9K3, 9K12, 9L9
0367 150413	Stirnrad	8F3, 8F9, 8.2H8, 8.4J7	0367 150980	Oelschlauch	9M11
0367 150433	Antriebswelle	7D9, 7D10, 7E6, 7.1E3, 8F5, 8F7, 8.2G5	0367 151000	Koerper	6F12, 6K12
0367 150453	Zugstange	7B4, 7C11, 7.1B2, 8C3, 8D9	0367 151004	Zahnriemenrad	6F12, 6K12
0367 150460	Exzenterbuchse	9L5, 9M2, 9M7, 9M11	0367 151010	Huelse	6G11, 6L11
0367 150470	Scheibe	9K2, 9K4, 9K7, 9K11	0367 151020	Piston	6G11, 6L11
0367 150480	Spulengeh.Luefter	7.1A2	0367 151030	Feder	9L3, 9L9, 9L12
0367 150490	Spulengeh.Luefter	7A5, 7A10, 8C3, 8.2C8, 8C9	0367 151040	Filtertopf	9L1, 9L3, 9L5, 9L8, 9L10, 9L12
0367 150530	Spindel	7E10, 7F6, 7.1F3, 8F8, 8G5, 8.2J6	0367 151050	Huelse	9K2, 9K12, 9L1, 9L8, 9M4, 9M10
0367 150540	Mutter	7F4, 7F11, 7.1F2, 8G3, 8G9, 8.2J8, 8.4J7, 8.5G7	0367 160030	Bolzen	6D11
0367 150550	Nippel	9L4	0367 160053	Welle	6B1
0367 150560	Reduzierstueck	9M8	0367 160064	Stellwelle K	1L7, 1.1L9
0367 150570	Oelrohr	9L3, 9L12, 9M9	0367 160090	Gleitstein	6G8, 6K8
0367 150580	Deckel, Re	7F6, 7F11, 7.1G3, 7G6, 8G5, 8H9, 8.2K8, 8.4L7	0367 190100	Bolzen	6F9, 6K9
0367 150590	Dichtung	8.2K8, 8.5H9	0367 160110	Keil	1K7, 1.1K12
0367 150600	Deckel li.	7G6, 7.1G3, 8H5, 8.5H9	0367 160120	Druckfeder	1K7, 1.1K12
0367 150610	Greiferlager, re FA	8F8, 8.2H6, 8.4H5	0367 160130	Buchse	6A2, 6A6, 6B4, 6E3, 6F4, 6G3
0367 150620	Greiferlager, li FA	7E6, 7.1E3, 8F3, 8.5F9	0367 160140	Buchse	8E3, 8F3, 8F9, 8.2H8 8.4H7, 8.5F7
0367 150630	Deckel	8H9	0367 160183	Hubexzenter	6G8, 6L8
0367 150700	Schlauch	9F3, 9F6, 9M7	0367 160200	Buchse	1J8
0367 150770	Buchse	7F6, 7F10, 7.1F3, 8G5, 8G8, 8.2J6, 8.5D7, 8.4K6	0367 160233	Kloben	6C3
0367 150780	Scheibe	6F11, 6K11	0367 160240	Bolzen	6A4
0367 150813	Stirnrad	7E6, 7E11, 7.1E3, 8.5F7	0367 160253	Zugstange	6K7
			0367 160273	Zugstange	6F7, 6K8
			0367 160290	Hebel	6F9, 6K9
			0367 160310	Bolzen	6A6, 6F7, 6D3, 6J7
			0367 160320	Nippel	1F4, 1L6, 1.1E4, 4J7, 4K1, 4M4, 5K1, 5L4, 6C3, 6G7, 6G10, 6L7, 6L10, 7E10, 8F8, 8.2H6, 8.4H5, 12B4
			0367 160333	Klemmkloben	1H10
			0367 160340	Hebel	1K9

Teile-Nr./Part-No.	Benennung/Des.	Tafel/Table	Teile-Nr./Part-No.	Benennung/Des.	Tafel/Table
0367 160344	Hebel	1K9	0367 250010	Oelfangschale	20E5
0367 160350	Zugstange	1K9	0367 250020	Schraubendreher	20A3
0367 160360	Bolzen	1K10	0367 250030	Maulschluessel	20C2
0367 160373	Kloben	1L9	0367 250044	Spulenausheber	6.1L12, 20K2
0367 160380	Bolzen	1L9	0367 250050	Oelfangmulde	20E5
0367 160383	Kloben	1L9	0367 310013	Kloben	1L5
0367 160390	Buchse	1J10	0367 310023	Zugstange	1L6
0367 160400	Ausgleichsstueck	1G10	0367 310030	Buchse	1L6
0367 160410	Blattfeder	1H10	0367 310044	Exzenter	4L8
0367 160420	Achse	1J8	0367 310103	Zugstange	4L6
0367 160430	Federhaken	5E3,5E4, 5E9, 5E10	0367 310133	Kloben	4H6
0367 160460	Stange	1K10	0367 310153	Stellring	4B4, 4B7
0367 160474	Gabel	1H9	0367 310160	Bolzen	4J7
0367 160480	Zugfeder	5D3, 5D9	0367 310180	Schauglas	1C3, 1.1C4, 9B2, 9B8, 9H3
0367 160493	Federbuegel	5D3, 5D9	0367 310190	Bolzen	1H9, 4C1,4C5
0367 160523	Polster	1K11, 20J6	0367 310203	Zugstange	1J6
0367 160530	Rolle	1H9	0367 310204	Hebel	1M6
0367 160563	Spindel	1K10	0367 310210	Gelenk	4D2, 4D6, 4E4,4E8
0367 160583	Stichst. Griff	1J12	0367 310280	Sicherungsblech	4D2, 4D4,4D6, 4D8, 4E2, 4E4, 4E6, 4E8, 12C1
0367 160600	Skala	1K11	0367 310284	Armwelle	1B9
0367 160633	Klemmbolzen	6F4	0367 310330	Buchse	1J3, 1K4, 4B4, 4B8, 4K3, 5K3
0367 160640	Stopfen	1L6, 6B1	0367 310360	Stopfen	4J7, 4L4, 5L4
0367 160660	Bolzen	5C3, 5C9	0367 310410	Klemmstueck	4K7, 4L7
0367 160680	Stift	6B1, 6D1, 6F1	0367 310830	Kolben	25K11
0367 160690	Buchse	1J12	0367 310860	Bolzen	25J11, 25M10
0367 160700	Anschlagblech	1M10	0367 310933	Stellring	4K3,4K5,5K5
0367 160710	Anschlagblech	1M10	0367 311010	Zugstange	25K11
0367 160720	Buchse	6A2	0367 311060	Buchse	4K5, 5K5
0367 160740	Gleitstein	6C11, 12B3	0367 311103	Lasche	4L1, 5L1
0367 170750	Distanzhuelse	1H10	0367 311130	Bolzen	4K3, 5K3
0367 170013	Mitnehmerrad	1C10, 1F11	0367 311150	Welle	4K1, 5K3
0367 170020	Buchse	10B9, 10H9	0367 311163	Oelrohr	4H4
0367 170033	Ausloesehebel	10C11, 10J11, 10.1D5	0367 311170	Bolzen	4K1
0367 170040	Klemmfeder	10G11, 10.1C5	0367 311193	Rahmen	4H1, 5H1
0367 170044	Spulerrad K	10H11, 10.1C5	0367 311210	Blech	4H2, 5H3
0367 170060	Messer	10B11, 10H11, 10.1D5	0367 311223	Hebel	4J5,5J5
0367 170070	Scheibe	10B11, 10H11, 10.1C5	0367 311230	Distanzstueck	25L10
0367 170083	Spulerrad K	10E9, 10L9, 10.1H3	0367 311240	Kugelbolzen	4H5, 5H5
0367 170090	Fadenfuehrung	10B9,10G11,10.1B5	0367 311260	Schlauch	25J11
0367 200330	Stichplatte	11K1	0367 311343	Zugstange	1L6
0367 210240	Untermesser	11K2, 20L2	0367 311500	Oelrohr	11D5
0367 232010	Nadelst.Rohr	2K11, 2F11	0367 330020	Exzenterscheibe	11B5
0367 232030	Fadenoese	30F2	0367 330044	Oelverteiler	12D4
0367 240040	Distanzrolle	11C11, 11M6, 12H5	0367 330053	Kulisse	12B3
0367 240440	Einsatz	11B8, 12G1	0367 330073	Klemmbolzen	12B2
0367 240453	Hebel	11B9, 12G3	0367 330080	Buchse	11E3, 12B2, 12C2
0367 240460	Welle	11C8, 12H2	0367 330093	Welle	12B1
0367 240470	Scheibe	11D8, 12J1	0367 330110	Zugstange	11D2, 12C2
0367 240480	Schieber	11C9, 12H3	0367 330123	Bolzen	11D1, 11E3, 12B1, 12C2
0367 240493	Zugstange	11D9, 12J3	0367 330133	Bolzen	12A3
0367 240503	Lager	11C8, 12H1	0367 330140	Messerstange	12C1
0367 240513	Kloben	11C10, 12H4	0367 330150	Buchse	12D2
0367 240520	Lagerplatte	11C11, 12H4	0367 330183	Bolzen	12A7
0367 240530	Huelse	11A11,11B11,11C11, 12G5, 12H5	0367 330193	Kloben	12B6
0367 240540	Distanzbuchse	11A10, 11B11, 12G5	0367 330203	Schaltnocken	12B6
0367 240563	Bandeinf. Platte	11A9, 12F3	0367 330213	Klinke	12C6
0367 240940	Bolzen	11B11, 12G3			

Teile-Nr./Part-No.	Benennung/Des.	Tafel/Table	Teile-Nr./Part-No.	Benennung/Des.	Tafel/Table
0367 330233	Handhebel	12C6	0367 331630	Bolzen	11C3
0367 330240	Zugstange	12A3	0367 331640	Bolzen	11C3
0367 330254	Schwenkhebel K	12C6	0367 331693	Lagerplatte	12C11
0367 330260	Bolzen	12B5	0367 331700	Bolzen	12C11
0367 330270	Arretierschr.	12D6	0367 331710	Buchse	12E2
0367 330280	Schalthebel	12A5	0367 331720	Druckfeder	12E3
0367 330290	Lagerbock	12E4	0367 337514	Abschneideinr.	12F6
0367 330300	Bolzen	11F3, 12D3	0367 350023	Buegel V	20L5, 25E12, 25L5
0367 330310	Rohr	12D3	0367 350040	Messertraeger FA	8B7, 8C3, 8.2C6
0367 330320	Drehfeder	12B7	0367 350050	Messer	8B5, 8B7, 20J2
0367 330330	Drehfeder	12D3	0367 350060	Klemmfeder	8B3, 8B7, 20J2
0367 330350	Mutter	12D6	0367 350070	Messer	8A3, 8B9, 20J2
0367 330370	Scheibe	12C6	0367 350083	Fadenz.Traeger V	8B3, 8B9, 8.2B8, 8.4B8
0367 330380	Rohrhalter	11D5, 12D3	0367 350103	Buchse V	8D3, 8E9, 8.2F8, 8.5D7
0367 330390	Federblech	12B6	0367 350113	Stellring	8E1, 8F12, 8.4H11, 8.4J11
0367 330400	Kloben	12C6	0367 350123	Hebel K	8F10, 8.2H9, 8.4H9
0367 330410	Zapfenschr.	12C6	0367 350130	Zugstange	8F10, 8.2J9, 8.4J9
0367 330420	Schaltblech	12B6	0367 350143	Kloben K	8G10, 8.2J9, 8.4K9
0367 330693	Lagerarm	11J5	0367 350150	Magnethalter	8F12, 8.4J11
0367 330700	Lagerbock	6D9	0367 350160	Hebel	8.2H12
0367 330713	Hubwelle	6D10	0367 350163	Hebel K	8F2, 8G10, 8.2K10
0367 330714	Hubwelle K	6D10	0367 350170	Bolzen	8F1, 8G11, 8.2K11, 8.4K11
0367 330720	Stopfen	11H11	0367 350180	Kurvenscheibe	8H5, 8H9
0367 330730	Klemmstueck	11K3	0367 350193	Hebel	8E1 8.4K10
0367 330740	Bolzen	11M5	0367 350200	Zugstange	8D1
0367 330773	Lager	11J3, 12B9	0367 350213	Winkelhebel	8E3
0367 330780	Obermesser	11L3, 20K2	0367 350220	Bolzen	8F5
0367 330810	Winkel	11H3	0367 350230	Zugstange	8E3
0367 330840	Kloben	11J3, 11J4, 12B10	0367 350243	Kloben	8H5
0367 330850	Bolzen	11J3, 12B9	0367 350250	Magnethalter	8H6
0367 330873	Schutzblech	20E5	0367 350260	Halter	20G6
0367 330880	Drehfeder	11H7	0367 350270	Winkel	9C10
0367 330893	Schlauch	9D2, 9D7, 9L7	0367 350280	Lasche	5L3, 25E10, 25.1F3
0367 330920	Schutzblech	12A2	0367 350290	Stichst. Hebel	25B11, 25.1B4, 26F8
0367 331010	Lagerbock	11E3	0367 350294	Hebl	26E9
0367 331023	Welle	11D2	0367 350300	Zeigerblech	25B11, 25.1B4, 26F8
0367 331034	Exzenter K	11B5	0367 350320	Anschraubkloben	25B10, 25.1B2
0367 331053	Halter	11L5	0367 350330	Stoessel	25C12, 25G12, 25.1H4, 26F1, 27B2, 27.1B2
0367 331063	Lager	11K4	0367 330403	Klemmkloben	26F1, 27B2
0367 331070	Buchse	11K4	0367 350413	Hebel	27B8
0367 331090	Buchse	11E2	0367 350430	Lasche	27B7
0367 331100	Druckfeder	11L4	0367 350443	Buchse	27A7
0367 331110	Stellschr.	11L3	0367 350483	Klemmring	27B7
0367 331123	Fuehrungskloben	11M4	0367 350490	Scheibe	25G12, 25.1J4, 26G1, 27C2, 27.1C2
0367 331133	Halter	11J4	0367 350713	Winkel	9E10
0367 331143	Abdeckblech	11H10	0367 350723	Schaltring	9E11, 10J3
0367 331150	Abweiser	11H8	0367 360123	Leitung	9C7, 9J7
0367 331160	Abweiser	11L4	0367 360153	Fadensp.Magnet K	10E5, 10.2L5
0367 331173	Schutzblech	11G8	0367 360170	Halter	26J1
0367 331180	Schlitten	11J3	0367 360183	Doppelleitung	27E5
0367 331190	Lagerbock	11L6	0367 360293	Lueftung K	10L4, 10.2K10
0367 331203	Kloben	11K5	0367 367649	FLP 13-2	27H5
0367 331210	Zugstange	11K5	0367 367654	Wart. Einheit WE3	27L12
0367 331223	Welle	11K6	0367 367704	Anschl.Teile K	27M3
0367 331240	Gewindebolzen	11K5	0370 221230	Druckfeder	6G7, 6L7
0367 331254	Oelverteiler	11C5			
0367 331260	Abfallrutsche	20E5			
0367 331344	Exzenter K	12C4			
0367 331520	Kloben	11C3			
0367 331573	Stellring	11E3			

Teile-Nr./Part-No.	Benennung/Des.	Tafel/Table	Teile-Nr./Part-No.	Benennung/Des.	Tafel/Table
0370 353072	Zyl. Boden	25L11	0467 150050	Deckring	6.1C2, 6.1C6
0381 110043	Raendelmutter	3D4, 3D7, 3F3, 3G7	0467 150054	Greifer	6.1B3
0381 110230	Raendelmutter	3E11	0467 150064	Spulengehaeuse V	7C2, 7D3, 7.1H2
0396 110470	Druckfeder	3B3, 3C8, 10A7, 10F11,	0467 150084	Spulengehaeuse V	7F1, 7H5, 7H10
0396 140050	Dichtscheibe	1D4, 11M6	0467 150094	Greifer K	7F1, 7G5, 7H2, 7H10, 8C11, 8G2
0396 160090	Buchse	31L11	0467 150104	Greifer K	6.1C7
0396 160330	Zugfeder	25J11	0467 150130	Abdeckblech	
0396 160553	Stellkloben	6B2, 6D2, 6D3, 6F2, 6F3	0467 150120	Spannungsfeder	6.1C11, 6.1D3, 6.1D7, 6.1J3, 6.1J7, 7D2, 7H2, 8.2E12, 20J2, 25.2D12, 25.2K10
0396 170060	Huelse	10E11, 10L11, 10.1H5	0467 150130	Abdeckblech	7E2, 7J2, 8.2F12, 25.2D6, 25.2D12
0396 170080	Druckfeder	10E9, 10L9, 10.1G3	0467 150230	Nadelschutz	7E2, 7J2, 8.2F12, 25.2D6, 25.2D12
0396 170160	Fadenfuehrung	3A2, 3A7, 10B7, 10G9	0467 150440	Spannungsfeder	6.1C11, 6.1J7, 25.2K8, 25.2K10
0396 170170	Gewindebolzen	3A2, 3B7, 10B7, 10G9	0467 150500	Scheibe	6.1J11
0396 170253	Spulerbock V	10D11, 10K11, 10.1F5	0467 150773	Antriebswelle V	8.4H5, 8.5F7
0396 350260	Arm	10D9, 10L9	0467 160040	Buchse	5C5, 5C10
0396 170270	Einrueck-Kloben	10E11, 10L11, 10.1G5	0467 160100	Stopfen	6D1, 6G1
0396 170283	Ausloesenoek. V	10D11, 10L11, 10.1G5	0467 160120	Scheibe	6A2
0396 170330	Spulerwelle	10B9, 10H11, 10.1C5	0467 160133	Schiebeexzenter	6G9, 6L9
0396 170160	Fadenfuehrung	10.1B3	0467 160140	Transp. Balken	6C3
0396 170170	Gew. Bolzen	10.1B3	0467 160144	Transp. Balken	6C3
0396 170260	Spulerarm	10.1G3	0467 160173	Hubwelle	6D1, 6F1
0396 250180	Druckfeder	31D4	0467 160200	Schwinge	6E1, 6E3, 6G1, 6H3
0396 350840	Druckfeder	10K4, 10.2H10	0467 160210	Scheibe	6E1, 6E2, 6G1, 6G2
0430 277360	Scheibe	10E9, 10L9, 10.1H3, 11C11, 11L6, 12H5	0467 160220	Bolzen	6C3
0467 100010	Fadenh. Schutz	10D7, 10K7, 10.1F1	0467 160230	Stopfen	1K10
0467 100284	Armwelle V	1B9, 1E9	0467 200220	Untermesser	11J2, 12D9
0467 100290	Gegengewicht	1B8	0467 200250	Klemmstueck	12D9
0467 100330	Schutzblech	26A8, 29F8	0467 200520	Untermesser	12D9
0467 100344	Armdeckel K	10F11	0467 210143	Blech	12E10
0467 100353	Kopfdeckel K	1C1, 1.1C1	0467 210183	Blech V	12E10
0467 100360	Stuetzfeder	9C3, 9C8, 9J8	0467 310070	Blech	4J3, 5J3
0467 100373	Armdeckel	10J11, 10.1E5	0467 310083	Welle	4B2
0467 100374	Armdeckel K	10M11	0467 310100	Stift	4B2, 4B6
0467 100390	Oelfilz	9D2, 9D7, 9K7	0467 310110	Filzring	4A4
0467 100400	Oelkissen	1D1, 1.1C1	0467 310123	Oelschlauch	4B1, 4B5
0467 100410	Oelfilz	9D1, 9D5, 9K5	0467 310130	Zugstange	4D4, 4D8
0467 100510	O-Ring	10H8, 10.1D2	0467 310140	Oelleder	4C4, 4C8
0467 100533	Kopfdeckel	1C1	0467 310150	Blech	4C4, 4C8
0467 110013	Fadenhebel	2B5, 2B8, 2B12	0467 310163	Bolzen	4D1, 4D4, 4D5, 4D8, 4F4, 4F8
0467 110220	Spannungsscheibe	3C3, 3D7, 3C12	0467 310173	Bolzen	4C3, 4C5
0467 110250	Umlenkstift	3C3, 3C7	0467 310180	Lenker	4D4, 4D8
0467 130283	Stoffdr. Stange	4G2, 4G6	0467 310193	Gabelhebel K	5D1, 5D7, 5K6
0467 130304	Federhebel V	5B2, 5B8, 5G7	0467 310200	Bolzen	4D1, 4D5, 5C1, 5C7, 5J6
0467 130320	Welle	5D2, 5D8, 5J7	0467 310213	Bolzen	4E6, 4E2
0467 130330	Winkel	5F11, 5G5, 5M10	0467 310233	Transp.Fuszstg.	4F4
0467 130340	Federfuehrung	5C2, 5C8, 5H7, 25.2C11	0467 340030	Buchse	31A5
0467 130354	Druckfeder	5B1, 5B7, 5G6	0467 340100	Schraube	31B5
0467 140170	Schieber	2M6	0467 340130	Bolzen	31E5
0467 150014	Greifer V	6.1C3, 7B2, 7D2, 7.1G2	0467 340160	Gew. Nippel	31E4
0467 150030	Oelrohr	7E1, 7J1, 8.2F11, 25.2D5, 25.2E11	0467 340230	Welle	31M11, 31C7
0467 150040	Deckring	7D1, 7H1, 8.2E12, 25.2C5,	0467 340263	Konsole V	31K11
			0467 340290	Winkel	31J11
			0467 340300	Riemenscheibe	31H9
			0467 340330	Schutzhaube	31H9

Teile-Nr./Part-No.	Benennung/Des.	Tafel/Table	Teile-Nr./Part-No.	Benennung/Des.	Tafel/Table
0467 340340	Winkel	31K8	0467 480244	Leitung K	29K11, 3H11, 25E8 25.2G6, 25.2G12, 25K8, 29E12, 29K11
0467 340353	Zahnriemenrad V	31J11	0467 590034	RAP 13-4	25.1B10
0467 340400	Buchse	31L11	0477 130040	Hebel	5D5, 5D11, 5J10
0467 340413	Riemenscheibe V	31L7	0477 160223	Kurbel	6B5, 6E4
0467 340423	Riemenscheibe V	31L7	0477 310084	Zugstange	4M4, 5M4
0467 340433	Riemenscheibe V	31L7	0477 330013	Lagerarm	12B11
0467 340443	Riemenscheibe V	31L7	0477 330210	Messerhalter	12C10
0467 340453	Riemenscheibe V	31L7	0477 330220	Unterlage	12C10
0467 340463	Riemenscheibe V	31L7	0477 330230	Gew. Platte	12C10
0467 340473	Riemenscheibe V	31L7	0477 330240	Obermesser	12C9
0467 340483	Riemenscheibe V	31L7	0477 330250	Kloben	12B9
0467 340520	Schutzhaube	31H4	0477 351150	Halter	26A8
0467 340560	Welle	31F4, 31D5	0477 360010	Halter	29F7
0467 340580	Walze	31L4	0477 360020	Halter	29G6
0467 340600	Lagerbock	31H2	0477 480084	Magnetventil	26G6, 26H11
0467 340633	Zahnrad	31J3	0477 480109	Knieschalter	27M7
0467 340640	Zahnrad	31H2	0556 000855	Scheibe	1.1H1
0467 340654	Kupplung K	31M11	0568 330100	Bundbuchse	5C1, 5C7, 5H6
0467 340670	Winkel	31G2	0578 000954	Zugfeder	1.1J11
0467 340680	Lagerbock	31M4	0667 150440	Spannungsfeder	25.2K10
0467 340703	Halter V	31F8	0667 150814	Spulengehaeuse	6.1D11, 8E11
0467 340720	Stehbolzen	31F8	0667 150830	Spule	6.1C9, 6.1J5, 8.4B11, 8.5B11, 10A11, 10G11, 10.1B5, 20M2, 25.2K9
0467 340730	Kettenrad	31F7, 31D8	0667 150840	Deckring	6.1B11, 6.1H7, 25.2J8, 25.2J10
0467 340750	Feder	31B1	0669 150860	Nadelschutz	6.1E11, 6.1L7, 25.2L8, 25.2L10
0467 340793	Halter V	31A5	0667 150870	Kegelst. Feder	8.1E9, 25.2K8
0467 340893	Arm V	31D6	0667 150870	Kegelst. Feder	6.1C10, 6.1H6, 8.1D12, 20M4
0467 340830	Lasche	31E3	0667 150880	Spule	6.1J5, 8.4B11, 25.2H4, 25.2J7, 25.2K9
0467 340850	Leiste	31M6	0667 150984	Spulengehaeuse K	25.2J4, 25.2L7
0467 340860	Abdeckung	31L2	0667 160170	Spindel	1.1F9
0467 340870	Welle	31K3	0667 495330	Halter	4J12
0467 340883	Arm V	31F4	0699 971580	Docht	1L6, 4C1, 4C5, 4D1, 4D5, 4D8, 4E8, 4H1, 4H4, 4J1, 4J7, 4L4, 5D1, 5D7, 6C3, 7B6, 7B11, 7.1B3, 8C5, 8C9, 9C8, 9J8, 9K8, 12B9
0467 340900	Gabel	31D6	0699 979100	Schlauch PVC (2,5LWx1)	1K1, 1L6, 4H1, 4H4, 4J7, 4L4, 5C4, 5H1, 5H4, 5L4, 6C2, 7E10 9K3, 9K6, 9K12, 9L3, 9L9, 8F8 9L12, 9M3, 9M5, 9M10, 8.2H6, 8.4H5, 9B1, 9B5, 9C3, 9C8, 9D3, 9D8, 9H5, 9J8, 11D4, 29B10,
0467 340910	Schutzhaube	31E9	0699 979104	Schlauch PVC (5LWx1)	9K6, 9L6, 7M6, 7.1M3, 9M2, 8F8, 9M6, 8M2, 8M6, 9C3, 9C7, 9D2
0467 340950	Scheibe	31F7, 31D8	0699 979106	Schlauch PE (4LWx1)	27L1
0467 341283	Walze	31F5	0699 979265	Schlauch, Pur	25.2C6, 25.2C12, 25.2H5
0467 341610	Platte	31B2	0699 979400	Schlauch PA11 (2,7LWx0,65)	26G3, 26G10, 26H7
0467 347549	Walzentransp. K SP 470	31A9	0699 979403	Schlauch PA11 (4LWx1)	26H4, 26L2, 29G3
0467 350110	Blasrohr	29D9			
0467 350120	Halter	29D9			
0467 350350	Halter	27H7			
0467 350400	Rohr	29B10			
0467 360230	Gehaeuse	10C2, 10C5, 10G5, 10H5			
0467 360240	Deckel	10A3, 10G3			
0467 360250	Bolzen	10A3, 10G3, 25.2H4			
0467 360260	Leiste	10B4, 10H4, 14D2			
0467 360300	Blech	25C3, 26D4			
0467 360380	Halter	29D12, 3G10, 25F8, 25K9			
0467 360410	Reflektorfolie	29G7			
0467 360420	Abdeckung	26D5			
0467 360474	Gestellsatz K	29C10			
0467 367959	Nadelkuehlung K	29A11			
0467 368039	Lichtschr. EK	26D6			
0467 367799	Z-Einrichtung K	27F11			
0467 367809	Z-Einrichtung K	26M5			
0467 367819	Z-Einrichtung K	26M11			
0467 368139	Z-Einrichtung K	27H9, 27J8			
0467 480224	Taster kpl.	26E9			

Teile-Nr./Part-No.	Benennung/Des.	Tafel/Table	Teile-Nr./Part-No.	Benennung/Des.	Tafel/Table
0699 989250	Rundschnur	1C1, 10D9, 10K9, 10.1F3, 1.1C1	0767 150050	Oelfangring	7B6, 7B10, 7.1B3, 8C5, 8C8, 8.2D6
0699 991580	Oeldocht	4G5, 4H1, 4H4, 4J1, 4J7, 4L4, 5H4, 5J1, 8C5, 8J9, 11B3, 11D1, 11J4	0767 150060	Scheibe	7C6, 7C9, 7.1C3, 8D5, 8D8, 8.2F6 8.4F6, 8.5D9
0699 991581	Docht	1K1, 6D1	0767 150070	Scheibe	7C6, 7C9, 7.1C3, 8D5, 8D8, 8.2E6, 8.4F6, 8.5D9
0699 991582	Pfeifenreiniger	4E2, 4E6, 7E11, 7.1C2, 8F9, 8.2H8, 8.4H7	0767 150084	Greiferlager K	7.1G4, 8G2
0699 991583	Oeldocht	1H2	0767 150143	Spannrolle V	1.1C6
0699 991587	Docht	4A2, 4A6	0767 150144	Spannrolle K	1C6, 1.1C6
0700 000091	Auflage	20E3	0767 150170	Spule	25.2C4, 25.2C10
0702 000073	Gew. Stift	7.1B3, 8C5, 8C8, 8.1E6, 8.2D6, 8.4E6, 8.5D9	0767 150184	Spulengeh. K	25.2C4, 25.2C6
0725 000520 B	Federring	15C4, 16K8	0767 150194	Greifer K	25.2C6
0742 002096	Ideal-Schelle	27K2, 27L2	0767 150230	Filtertasche	9L1; 9L10; 9M5
0744 001793 B	Kuppl. Stecker	27L2	0767 150234	Filter K	9L1; 9L10; 9M5
0744 001793 A	Kupplungsdose	27L2	0767 150244	Greiferlager K	8.2L6
0744 001796	Schlauchtuelle	27K2	0767 150324	Greifer K	6.1A10, 8.4M9
0744 050242	Zahnscheibe	20L9	0767 150334	Greifer K	25.2J8
0746 001023	Buchse	30F8	0767 150343	Greiferwelle	8.2F6, 8.4G5, 8.5E9
0757 150084	Greiferlager	7.1G5	0767 150350	Spindel	8.2H6, 8.4J5, 8.5G9
0767 100010	Stopfen	1.1B6	0767 150374	Greiferlager K	8.5G6
0767 100024	Lagerhuelse K	1C11, 1F12	0767 150413	Schwenkhebel	8.2F8, 8.4F7, 8.5F9
0767 100034	Armwelle	1C9	0767 150420	Spulgeh. Luefter	8.5D11
0767 100044	Lagerhuelse K	1D10, 1F10	0767 150484	Spulengeh. K	6.1J3, 8.2C11, 8.2E12, 25.2C12
0767 100180	Fadenh. Schutz	10D7, 10.1F1, 10K7,	0767 150494	Spulengehaeuse K	6.1K7, 8.4E11, 8.5E11, 25.2L10
0767 100234	Armwelle K	1F9	0767 150504	Greifer V	6.1H3, 8.2C11, 8.2D12, 25.2C12
0767 100243	Schlauchhalter	9B8, 9H8	0767 150514	Greiferlager K	8.2M10
0767 100263	Schlauchhalter	9B4	0767 150524	Greiferlager K	8.4M7
0767 100270	Dichtscheibe	3C4, 3C7	0767 150534	Greiferlager K	8.4L5
0767 100304	Armdeckel K	10L11, 10.1H5	0767 150540	Mittelteilhalter	8.4B6
0767 100344	Armdeckel K	10E11	0767 150550	Bolzen	8.4H5
0767 110014	Fadensp. Traeger 1-Nadel	3D3	0767 150560	Luefter	8.4D8
0767 110024	Fadensp. Traeger 2-Nadel	3E7	0767 150574	Greifer K	6.1G6, 8.4D11, 25.2J10
0767 110030	Stift	3D2	0767 160094	Deckeleinsatz K	1.1D11
0767 110043	Hebel	5E9	0767 160114	Deckeleinsatz K	1.1G9
0767 110093	Fadenhebel V	2B11, 2F3	0767 160363	Stellring V	1.1A11
0767 110163	Halter V	3J3	0767 160370	Gleitlager	1.1A10
0767 110313	Aufnahme V	3M2	0767 160410	Rachen	1.1E8
0767 110320	Fadenf. Blech	3K3	0767 160434	Zylinderplatte K	1.1G1
0767 120050	Nadelstange	2L2	0767 160450	Zylinderplatte	1.1J3, 1.1J7
0767 120054	Nadelstange K	2M2	0767 160454	Zylinderplatte K	1.1G5
0767 120060	Nadelstange	2L1	0767 160460	Kolbenstange	1.1K3, 1.1M7
0767 120064	Nadelstange K	2M1, 2F6, 2F7, 2F9	0767 160470	Kolbenstange	1.1K3
0767 120080	Nadelstange	2L2	0767 160480	Kolbenstange	1.1L3
0767 120084	Nadelstange K	2F2, 2F8	0767 160520	Zyl. Stift	1.1B10
0767 120100	Fadenoese	2L2	0767 160534	Hebel V	1.1B10
0767 130020	Buchse	25C10, 25G12, 25K3, 25.1H4, 27.1B2	0767 160540	Bolzen	1.1J8
0767 140014	Deckel K	1D6, 1.1D6	0767 160630	Fede	1.1C8
0767 140050	Verschlusszchr.	1D5, 1.1D5	0767 160640	Federhaken	1.1H11
0767 140120	Schieber, li	2M4, 2F9	0767 160660	Bolzen	1.1K10
0767 140130	Schieber, re	2M7, 2F9	0767 160670	Exzenter	1.1B9
0767 150014	Greiferlager K, re	7G8	0767 160683	Kloben K	1.1K8
0767 150024	Greiferlager K, li.	7G7	0767 160690	Anschlag	1.1M4
0767 150034	Greiferlager K, re	8J10	0767 160700	Ansatzschr.	1.1H1
0767 150044	Greiferlager K, li	8J7	0767 160710	Traegerkoerper	1.1E8
			0767 160714	Buchse K	1.1A6
			0767 170160	Bundbuchse	10C9, 10.1C3, 10H9

Teile-Nr./Part-No.	Benennung/Des.	Tafel/Table	Teile-Nr./Part-No.	Benennung/Des.	Tafel/Table
0767 240014	Antrieb K	11D9	0767 360070	Schelle	29F3, 30F8
0767 250020	Lehre	20B4	0767 367629	RFW 13-3	25.2A5
0767 290020	Lehre	20D11	0767 367659	Teiles.Stichl. K STLS 12-2	29G12,
0676 290040	Lehre	20B11	0767 367669	Lichtschr.Ho. K LR13-4	29F6
0767 290050	Lehre	20C11	0767 490060	Abdeckung	25A8, 25F9
0767 290070	Lehre	20C11	0767 490330	Halter	15J3
0767 290010	Einstellehre	20J2	0767 490334	Halter K	15J3
0767 310014	Gelenk	4D4	0767 490350	Fadenanz. Feder	25.3L4
0767 310034	Hubgetriebe	4M4, 5M4	0767 490360	Distanzbuchse	25.2K6
0767 310053	Nadelstange	4F8	0767 490383	Schluessel V	25.3K7
0767 310063	Bolzen	4J7	0767 590034	RAP 13-2	25L8
0767 310074	Gelenk	4D8	0767 590044	HP 13-7	25M8
0767 310080	Filzring	4A8	0767 590054	FLP 13-2	27.1H5
0767 310093	Oelrohr	5H4	0767 590064	WTA 13-2 Teilesatz K	31F12
0767 310103	Oelrohr	5H4	0767 590094	Lichtschranke K LR 13-4	28D6
0767 310114	Zylinder K	25L11	0767 590144	RAP 13-6	25L8
0767 330034 M	Abfallblech K	11J9	0767 590184	RAP 13-7	25M8
0767 330044	Schwenkhebel, K	12C5	0767 590194	RFW 13-8	25.2A10
0767 350020	Messertraeger	25.2B4, 25.2B10	0767 590204	Pn. Zusatzsp.	3A10
0767 350033	Halter V	25.2B6, 25.2B12	0767 590234	RFW 13-9	25.2G7
0767 350050	Gehaeuse	25.2L2	0767 590244	RFW	25.2H10
0767 350060	Halter	25.2K1, 25.2E1, 25.2E7	0767 590264	Fehlstickerkenn. FSE13-2	25.3J9
0767 350070	Hebel K	29J5	0767 590274	Fehlstickerkenn. FSE13-1	25.3G9
0767 350074	Hebel K	29J5	0768 110020	Fadenoese	3D2
0767 350080	Hebel K	29J5	0768 110030	Platte	3B9
0767 350090	Zapfenschr.	29L6	0768 110040	Spannungsplatte	3B11
0767 350103	Hebel	29M7	0768 110050	Membrantuch	3B10
0767 350120	Ansatzschr.	29L7	0768 110060	Kolben	3B10
0767 350130	Winkel	29H4	0768 110070	Verstellbuchse	3C9
0767 350140	Puffer	29J2	0768 110080	Bolzen	3D9
0767 350150	Platte	29,J2, 29K4	0768 110124	Fadenfuehrung K	3E12
0767 350170	Platte	29H2	0768 110134	Fadensp.Traeger K3B12	
0767 350190	Zugfeder	29H1	0768 110140	Aufkleber, Einfaed.	3B11
0767 350203	Gehaeuse V	29H4	0768 350160	Rolle	8G10, 8.2K10, 8.3K10 8.4K10, 8.1G3, 8F2
0767 350210	Winkel	29L2	0791 001055	Stuetze	20F3
0767 350220	Mutter	29M3	0791 001081	Garnst. Rohr	20B9
0767 350230	Riemenschutz Vo	29L7	0791 001084	Garnst. Rohr	20D9
0767 350250	Skala	29H4, 29M4	0791 001085	Garnst. Rohr	20C8
0767 350310	Messertraeger	25.2H5	0791 001086	Garnst. Rohr	20A8
0767 350380	Fadenziehmesser	8.2B8	0791 001088	Garnst. Rohr K	20D8
0767 350390	Gegenmesser	8.2B6	0791 001090	Garnhaltearm	20C7
0767 350400	Kurvenscheibe	8.2L8	0791 001091	Garnhaltearm	11B7, 20B6,
0767 350410	Klemmfeder	8.2B6	0791 001093	Scheibe	20A6, 20C6
0767 350464	Befestigung K	25E10, 25.1G3	0791 001094	Linsenschr.	20A6, 20C6
0767 350483	Halter V	25.2H5	0791 001095	Mutter	20A6, 20B7
0767 350540	Gegenmesser	8.4C6	0791 001096	Fadenfuehrung	20B7
0767 350570	Klemmfeder	8.4B6	0791 580100	Zentrierkegel	20B6
0767 350580	Fadenziehmesser	8.4A6	0792 071010	Blindstopfen	29K11
0767 350590	Halter	6.1B10,6.1H6,8.4C8	0793 020147	Gleitlager	1.1C12
0767 350600	Kurvenscheibe	8.4M7	0797 000314	Magnetventil	25J9
0767 357514	Fadensp.Lueftung 767-FA-Kurz	10M2	0797 000315	Magnetventil	25D8
0767 357524	Fadensp.Lueftung	10F2	0797 002214	T-Verbindung	9L3, 9M8, 9M12
0767 360010	Deckel	25.2E4, 25.2E10, 25.2K4	0797 003031	Druckleitung K	27M5
0767 360020	Blech	25C2, 25A8, 25F8	0798 000677	Kabelkanal	15E1, 16G3
0767 360043	Winkel K	29C6, 29E6	0798 003292	Betaetig. Hebel	15J9, 16D5
0767 360050	Halter	29D1, 25.2F2, 25.2F8, 30E7			
0767 360060	Blech	29C4			

Teile-Nr./Part-No.	Benennung/Des.	Tafel/Table	Teile-Nr./Part-No.	Benennung/Des.	Tafel/Table
0798 120401	Cord-Clip	30A5, 30B9	0990 240165	Schutzstopfen	1B4, 1.1B4
0798 123922	Buchse	25.2H7	0990 240181	Stopfen	1C4, 1.1C4
0798 500088	Trafo, Naehlicht	29F2, 30J6	0990 254244	Knieschalter	27M7
0798 783001	Knieschalter K	27K7	0990 254306	Positionsgeber	15H9
0801 510930	Daempfring	25D10, 25G12, 27C2 27.1C2, 25.1J4, 26G2, 35K5	0990 420055	Docht	7C4, 7C10
0893 211058	Federring	29B8	0990 810038	Kasten	20D3
0893 037247	Senkschr.	11B8, 12G1	0992 000750	Schraube	11A8, 11K5
0893 066950	Zyl. Schr.	8C3, 8C9	0992 002667	Senkschr.	11K3
0893 067167	Schraube	2C4, 2C7, 2D10, 30G2, 30G4, 30J5	0992 002697	Senkschr.	11A9, 12F3
0893 067177	Zyl. Schr.	30J2	0992 006877	Li. Zyl. Schr.	30H2
0893 520720	Gewindestift	3G1, 3H1, 3H5, 3J5, 7B6, 7B10, 7.1B3, 8C5, 8C8	0992 007437	6kt. Schr.	11A8
0893 521050	Gewindestift	8F5	0992 009580	Li. Zyl. Schr.	11A9
0894 042827	6kt. Schr.	26B4	0992 013147	Zyl. Schr.	2D2
0894 440368	Zahnscheibe	20F4	0992 013730	Zyl. Schr.	30G4
0894 450366	Faecherscheibe	26C3	0992 016580	Zyl. Schr.	6.1C2, 6.1C6, 6.1A11, 6.1J2, 8.2E11, 25.2C5, 25.2C11, 25.2K8, 25.2J10
0894 450368	Faecherscheibe	1.1E8, 25B2	0992 023560	Li. Senkschr.	6.1D3, 6.1D7, 6.1D11, 6.1J3, 6.1K7, 8.2E12, 25.2D12, 25.2K8, 25.2L10
0894 450378	Faecherscheibe	2B2, 4J3, 5J3, 9B2, 9B6, 9J6, 10B9, 10G9, 10.1B3, 11K4, 13B8, 25D10, 25D2, 25.1E4, 25.1G3, 26H8	0992 023577	Li. Senkschr.	6.1D3, 6.1D7, 6.1D11, 6.1J3, 6.1K7, 8.2E12, 25.2D12, 25.2K8, 25.2L10
0894 450388	Faecherscheibe	8F12, 8.2J12, 8.4J11	0992 023640	Gew. Stift	2C6, 2C9, 2D12, 2H3
0894 450408	Faecherscheibe	2D2, 26B4	0992 023677	Li. Zyl. Schr.	1D3, 1.1D3
0894 450418	Faecherscheibe	20L9, 30C4	0992 023760	Zyl. Schr.	12A3, 12D3, 26E8, 25A10, 25.1A3
0894 451368	Sternfeder	4L8	0992 023800	Schraube	1K9
0894 572007	Linsenschr.	26B7	0992 023810	Gew. Stift	8.2F12, 25.2E6, 25.2E12, 25.2L8, 25.2L10
0984 572027	Zyl. Blechschr.	26B7	0992 023820	6kt. Mutter	7F4, 7F11, 7.1F2, 8G3, 8G9, 8.2J8 8.4K7, 8.5G7
0894 572220	Zyl. Blechschr.	12A2	0992 023890	Senkschr.	1E7, 1.1E3, 30K2
0894 582430	Senkblechschr.	9C4, 9B9, 9J8, 9J9	0992 024030	Schraube	1L3, 20G2, 30C4
0894 621927	Schraube	26J1, 27K1	0992 123660	Zyl. Schr.	30E2
0894 700748	Federring	6D9	0993 021160	Zyl. Schr.	11E3, 12E4
0894 700758	Federring	2B2	0993 031347	Senkschr.	7C8
0895 361010	Zyl. Stift	11K5	0993 031367	Senkschr.	11H8, 11L2, 11L3
0895 361180	Zyl. Stift	11B9	0993 037240	Senkschr.	6L11
0895 365940	Stift	5D2, 5D8	0993 037660	Senkschr.	1K2
0907 010060	Ausgl. Stueck	20F3	0993 060417	Schraube	1K1, 30C2, 30C4
0907 010070	Ausgl. Stueck	20E3	0993 060927	Schraube	10.1D5, 11G9
0907 020910	Huelse	27K3	0993 060950	Zyl. Schr.	6E1, 6E3, 6G1, 6G3, 11D3
0907 030670	Stopfen	20F3, 26A4, 26J2	0993 060957	Zyl. Schr.	27H7
0907 050114	Erdungssatz	20M9	0993 060967	Schraube	10B11, 10C11, 10.1D5, 10J11
0907 487519	Anbausatz K	30E2	0993 060987	Schraube	9E10
0917 030510	Schelle	25D9, 25.2D3, 25.2D9, 25.2J3	0993 061327	Schraube	4F4, 4F8, 11D2, 11J9
0933 000587	Tellerfeder	7E10, 7F4, 7.1F2, 8G3	0993 061347	Schraube	13D8
0935 004395	Spannstift	5C1, 5C2, 5C7, 5H6, 5H7	0993 061367	Schraube	10G4, 26B4
0961 402443	Zahnriemenrad V	31M11, 31C7	0993 061427	Schraube	26B4, 26B6
0965 510230	Bolzen	31J3	0993 061557	Schraube	9C1, 9C5, 9J5
0971 430190	Scheibe	1E5, 1E6, 1.1E6, 25.2B3, 25.2B8, 25.2H3	0993 066540	Schraube	8B5, 8B7, 8B8
0980 424370	Buchse	31C2, 31E3	0993 066720	Schraube	7F9, 8H8
0988 880120	Stuetzscheibe	1J3	0993 067418	Zyl. Schr.	27H7
0990 120093	Keilriemen	16.1G6, 16.1H6	0993 087008	Halbrd. Schr.	11J10, 29M4
0990 120094	Keilriemen	16.1J6			
0990 240057	Buchse	20B8			
0990 240155	Schutzstopfen	1A3, 1.1A3			
0990 240164	Stopfen	1C3, 1.1C3			

Teile-Nr./Part-No.	Benennung/Des.	Tafel/Table	Teile-Nr./Part-No.	Benennung/Des.	Tafel/Table
0993 087018	Halbrd. Schr.	27H7, 29J4, 29E8	0993 911347	Zyl. Schr.	26K1, 27K3
0993 151137	Halbrd. Holzschr.	26B3	0993 911467	Zyl. Schr.	20K5
0993 151560	Halbrd. Holzschr.	20E4	0993 911700	Kopfschr.	10D3
0993 190347	Scheibe	8A3, 8B9, 9D11, 11D3, 11G8, 30L3,	0993 920698	Gewindestift	20H2
0993 190360	Scheibe	11B5	0993 920988	Gewindestift	11D3
0993 190367	Scheibe	10B4, 10H4, 11H3, 10.1F1	0993 920998	Gewindestift	9D11, 11E5
0993 190377	Scheibe	8B3, 8B9, 26G8	0993 921008	Gew. Stift	1D6, 4J8
0993 190387	Scheibe	11B11, 26K3, 27K2	0993 921118	Gew. Stift	6F5, 6F6, 6G5, 6L5, 11B5
0993 190407	Scheibe	20J6	0993 921128	Gew. Stift	6F12, 6K12
0993 190417	Scheibe	26B3	0993 921228	Gew. Stift	5D1, 5D7, 6G12, 6L12
0993 190467	Scheibe	20D8, 20D9	0993 940758	Gew. Stift	8.2F11, 25.2D5, 25.2D11, 25.2L8, 25.2M10
0993 260927	Fluegelschr.	11A11	0993 940778	Gew. Stift	6.1D2,6.1D6, 6.1K2, 6.1F10, 6.1M6
0993 300367	Scheibe	1K2	0993 941118	Gew. Stift	4K8
0993 340547	6kt. Mutter	9D10	0993 950818	Gew. Stift	3M2, 31F7
0993 340567	6kt. Mutter	20F4	0993 952948	Gew. Stift	12C1
0993 340577	6kt. Mutter	5C3	0993 960427	Schraube	30F2
0993 340580	6kt. Mutter	26F1	0993 970977	Zyl. Schr.	11H11
0993 340587	6kt. Mutter	11C11	0993 991700	Fl. Kopfschr.	10D3, 3H11, 10.2L3
0993 411208	Raendelmutter	3B3, 3C8, 107, 10F11, 10.1A5	0993 991910	Fl. Kopfschr.	5C6, 5C11, 5J12
0993 520930	Gew. Stift	7D9	0994 041844	6kt. Schr.	5E8
0993 521030	Gew. Stift	6B4	0994 050367	6kt. Mutter	11D5, 26C3
0993 521050	Gew. Stift	7E11, 8E1,	0994 050377	6kt. Mutter	5E8
0993 521090	Gew. Stift	5C3, 5H8	0994 050387	6kt. Mutter	26K3, 27K1
0993 521110	Gew. Stift	7C10	0994 050407	6kt. Mutter	26B5
0993 521140	Gew. Stift	4J7	0994 071347	6kt. Mutter	27B8
0993 521578	Gew. Stift	1K8	0994 330757	Halbrd. Kerbnagel	10C11
0993 543110	Gew. Stift	9D10	0994 361128	Zyl. Schr.	5B9
0993 601037	6kt. Holzschr.	15H4	0994 460708	Schraube	1H1, 11J4, 30M1
0993 904008	Schraubendreher	30D4	0994 461018	Zyl.Schr. M5x12	4E1, 4E5, 4E9, 10C7, 10C11, 10J7, 10J11, 24D6,24D10, 10.1E6, 10.1E1
0993 910488	Zyl. Schr.	12C11	0994 461128	Zyl. Schr.	5E8, 5E9
0993 910618	Zyl. Schr.	8A3, 8B9	0994 461138	Zyl. Schr.	6B3
0993 910638	Zyl. Schr.	11D2, 30D2, 30L3	0994 465348	Zyl. Schr. UFK	1B1, 1C3, 4E1, 4E5
0993 910708	Zyl. Schr.	11K4	0994 520020	Schneidschr.	20K8
0993 910807	Zyl. Schr.	8H6	0994 529920	Schneidschr.	11K8
0993 910808	Zyl. Schr.	26G8	0995 110210	Verschl. Schr.	1F4, 1.1F4
0993 910817	Zyl. Schr.	8G6, 8G11, 8H5, 8H6, 10D7, 10.1F1	0995 340617	Mutter	20C8, 20D9
0993 910818	Zyl. Schr.	8H5, 11B5, 11K5, 12B6	0996 010888	Sich. Ring	31M4
0993 910827	Zyl. Schr.	8H5, 8J9	0996 010968	Sich. Ring	1E12
0993 910837	Zyl. Schr.	6B2, 9D10	0996 021158	Sich. Ring	7F10
0993 910838	Zyl. Schr.	11C3, 11D8, 26F1	0996 021188	Sich. Ring	31M3
0993 910847	Zyl. Schr.	11C5	0996 031118	Tellerfeder	6A4
0993 910857	Zyl. Schr.	11H3	0996 031828	Tellerfeder	8G3
0993 910887	Zyl. Schr.	27B7	0996 070068	Sich. Scheibe	10D2, 10.1H5
0993 910888	Zyl. Schr.	11J4	0996 070078	Sich.Scheibe	7C4,7D11, 31B6, 31D1
0993 911028	Zyl. Schr.	4J3, 5J3, 26G5, 27C10, 27J7	0996 070088	Sich. Scheibe	5C1, 5C7, 6A6, 6D3, 6F7, 6F9, 10D9, 10L1, 10.2K6
0993 911038	Zyl. Schr.	26H8	0996 070108	Sich. Scheibe	5B2, 5B8
0993 911048	Zyl. Schr.	11C3, 11C9, 11D9, 11D9, 11J3	0996 080200	Rillenkugellager	7C9, 7D6,7.1D3
0993 911067	Zyl. Schr.	11K4, 11K5, 11L5, 11L6	0996 080700	Rillenkugellager	7C6,7C9,7E4, 2D11
0993 911087	Zyl. Schr.	8B3, 8B8, 11L4, 11B11	0996 082340	Rillenkugellager	7C6, 7C11
0993 911237	Zyl. Schr.	8G12	0996 086990	Rillenkugellager	1F12
0993 911238	Zyl.Schr.	6D9, 6D10, 27K2	0996 101068	Sprengring	1C11, 1F12
0993 911268	Zyl. Schr.	4L1, 5B5, 5B10, 5L2			
0993 911278	Zyl. Schr.	26F8			

Teile-Nr./Part-No.	Benennung/Des.	Tafel/Table	Teile-Nr./Part-No.	Benennung/Des.	Tafel/Table
0996 120387	Stellring	11A11	0999 202439	Steuerleitung	10E5, 10L5
0996 120407	Stellring	12A4	0999 202449	Bef. Winkel	20L7
0996 120420	Stellring	11E5	0999 210580	Spaeh.-Lager	11D9, 11H3, 12H3
0996 131360	Kugelknopf	11K6, 31C1	0999 210825	Zahnriemen	31J11
0996 283840	Dichtring	1.1F4	0999 210831	Gelenklager	31B5
0996 400020	Rollenkette	31F7	0999 210834	Dichtring	6B4, 6B6, 6E3, 6G4
0996 400023	Steckglied	31F8	0999 210839	Sinterbuchse	1H10, 11B9, 12G2
0996 610290	Winkelgelenk	5D5,5D11, 5F5,5F11	0999 210883	Sinterlager	11C8, 11C9, 12H1, 12H3
0997 153500	Steckhuelse	9B9, 26H11	0999 210885	Flanschgehaeuse	31B2, 31M10
0997 700894	Aderleitung	26C5, 26F6, 26G6, 26G11	0999 210886	Zahnriemen	31C7
0998 830318	Halbmondtring	6C2	0999 210907	Gleitlager	11M4
0998 852260	Simmerring	6F10, 6K10	0999 220475	Schlauchklemme	29B10
0998 856800	Simmerring	1L7, 1.1M11	0999 220484	Ventil	25.1D6, 25.1L6, 27.1E3
0998 856900	Simmerring	6F6, 6K6	0999 220654	Befestigung	25E10
0998 857800	Simmerring	1L8, 1.1M11	0999 220692	Behaelter	27M12
0998 859400	Simmerring	8H3, 8H9, 8.2L8, 8.4L7, 8.5H7	0999 220693	O-Ring	27L12
0998 860470	O-Ring	8.2E12, 25D12, 25.2D6, 25.2D12	0999 220694	Schlauchklemme	6A4
0998 860530	O-Ring	7E4, 7E11, 8F3, 8F8	0999 220705	Anschlussplatte	25G2, 29E12, 29K10, 31B11, 25.2F6, 25.1E6, 25.1L6, 25.2F12
0998 860670	O-Ring	6G6, 6L6	0999 220706	Anschlussplatte	3H9
0998 861590	O-Ring	10E9, 10M9, 10.1H3, 20G5	0999 220710	Saugventil	9M1, 9M4, 9M10, 9L3, 9L9, 9L12, 9D3, 9D7, 9D8
0998 863300	O-Ring	7D8, 7E8	0999 220720	Befestigung F	11M6
0998 880120	Paszscheibe	1J3, 1J4	0999 220726	Befestigung K	11M5
0998 881020	Paszscheibe	10L4, 10.2K10	0999 220736	Membrane	27K11
0998 881040	Paszscheibe	10D9, 10L9	0999 220742	Schauglas	27K11
0998 881070	Paszscheibe	6A5, 6D4	0999 220852	Lippenring	25K11
0998 881110	Paszscheibe	5D6, 5D12, 5J11	0999 220864	Zylinder, doppelt	29H1
0998 881520	Paszscheibe	11C8, 27B8	0999 230518	Dichtring	7C8, 7D7, 7D11, 7E4, 7.1E2, 7.1E4, 8F5, 8F7, 8F9, 8.2G4, 8.3H8, 8.4G3, 8.4H7, 8.5F7, 8.5F9
0998 881620	Paszscheibe	6B2, 7D6, 7D9, 7.1E3, 8F5, 8F7, 8.2G5, 8.4H5, 8.5D7	0999 230523	Nadelhuelse	31D8
0998 881940	Paszscheibe	10.1G3	0999 230538	Dichtring	8D3
0999 181317	Kabel	11L9	0999 230563	Nadelhuelse	31J3
0999 187900	Leitung	9C6, 9J7	0999 232103	Nadelhuelse	31F4, 31F7, 31D6, 31D6
0999 190245	Flasche	9L3, 9M9, 9M12	0999 240271	Dichtring	27L2
0999 190264	Stopfen	1C5	0999 240301	Doppelnippel	27K11
0999 200985	Mikroschalter	9E10	0999 240302	Doppelnippel	25E3, 29E10, 25G1, 27G1, 27.1D3, 27.1F2, 25D6, 25H6, 25.1D7, 25.1E6, 25.1K7, 25.1M6, 25.2K5
0999 201018	Kabelkanal	26B3	0999 240303	Doppelnippel	27.1G1, 25L3, 25.1K8
0999 201114	Fl. Stecker	20J8	0999 240341	Schottverschr.	25L4, 25.1L10, 27H3, 27.1H3
0999 201154	Bef. Schelle	4H2,5G3, 8H6,11D5	0999 240353	WE-Verschr.	27L3
0999 201311	Steckergehaeuse	25.2D3, 25.2D9, 25.2J3	0999 240376	T-Stueck	9M6
0999 201312	Buchsengehaeuse	25.2E1, 25.2E7, 25.2L1	0999 240385	Wi-E-Verschr.	29J10, 31C6
0999 201313	Buchse	25.2E1, 25.2E7, 25.2L6	0999 240389	Schlauchtuelle	25.2E5, 25.2E11, 25.2L5
0999 201517	Magnet GS	10E5, 10L5, 10.2J11, 10.2L5	0999 240391	Wi-E-Verschr.	29G1
0999 201528	Tuelle	20E7	0999 240392	Wi-E-Verschr.	25K4,25C6,25H6, 25.1B7, 25.1J10
0999 201573	Magnet, Hub	8H6, 8H11, 8.2K11, 8.4L11	0999 240393	T-ES-Verschr.	3F9, 25.1J6
0999 201600	Steckhuelse	9B7, 9J7, 27L7	0999 240404	GD-Verschr.	13J7, 25J10
0999 201617	Federhebel	9E10			
0999 201705	Magnet	11G9			
0999 201751	Kabelband	4F2			
0999 202159	Codierung	10F5, 10L5			
0999 202161	Messerkontakt	10F5, 26D3			
0999 202163	Stecker	10F5			

Teile-Nr./Part-No.	Benennung/Des.	Tafel/Table	Teile-Nr./Part-No.	Benennung/Des.	Tafel/Table
0999 290032	Getriebe	31J11	9202 001658	Zyl. Schr. M3x6	7E2, 7J2, 8.2F12, 12C9, 14F8, 25.2D6
9041 100015	Oeldocht, rd.	4D4, 4D8, 4D12, 4E4, 4E8, 4E12, 4K8, 5D1, 5D7, 5L4, 5K6, 7B6, 7.1B3, 8C5, 8C9, 8.2D8, 8.4D7, 11D5, 12B9	9202 001668	Zyl. Schr.	8.2B8, 8.4A8
9041 100020	Oeldocht, rd.	1K1, 4H4, 6F1	9202 001678	Zyl. Schr.	2L11, 8B9, 12B1
9041 100031	Oeldocht, rd.	1H1	9202 001688	Zyl. Schr.	12A9
9041 100212	Baumwolldocht	9D3, 9D8, 9K8, 9D2, 9D7, 9L7, 8D5, 8D8, 8.4E6, 8.2E6, 7.1C2	9202 002057	Zyl. Schr.	8G6, 9C11, 12D5
9047 000011	Naehm. Oel	20D2	9202 002058	Zyl. Schr.	25B11, 25J5, 25.1D5
9081 100251	Schr. Dreher, ger.	20H2	9202 002063	Zyl. Schr.	1.1E8
9081 500010	Schraubendreher	20B2	9202 002067	Zyl. Schr.	8G6, 8G11, 10D7, 10K7
9081 500051	Schraubendreher	20B2	9202 002068	Zyl.Schr.	1H8, 7G4, 7G6, 7G11, 7.1G3, 8H5, 10E4, 10L4, 10L5, 8H3, 8.2J9, 8.2K11, 8.4L5, 8.4L7, 8.4K9, 8.4K11, 8.5H7, 8.5H9, 8G5, 10.2L4, 10.2J10, 10.2K11, 12C3
9120 010100	Rillenkugellager	7E5, 7F6, 7E10, 7E11, 7.1E2, 7.1F3, 8E1, 8E5, 8E8, 8F3, 8F8, 8F9, 8G8, 8D5, 8.2F6, 8.2H8, 8.2J6, 8.4J7, 8.4J7, 8.4F6, 8.5F7, 8.5D9	9202 002077	Zyl. Schr.	8H5, 8J9, 8.2H9, 8.2J9, 8.4M7
9120 010150	Rillenkugellager	7.1E2, 7.1D3, 8E5, 8E7, 8.2F6, 8.4F5, 8.5E9	9202 002078	Zyl. Schr.	4G2, 5G3, 5G4, 12D9
9120 020100	Rillenkugellager	7.1C3, 8.2E8, 8D3, 8D9, 8.5F9, 8.4E7	9202 002088	Zyl.Schr.	7G6, 7G10, 7G11, 7.1G3, 8H5, 8H8, 8H9, 8H10, 8F1, 8F10, 8.2K10, 8.2H9, 8.2L6, 8.2L8, 8.4L5, 8.4L7, 8.4L10, 8.4H9, 8.5H9, 12J1
9120 030200	Rillenkugellager	1B10, 1E10	9202 002097	Zyl. Schr.	1J3, 1J4, 11K1, 1.1D11
9120 030041	Rillenkugellager	2C4, 2C7, 2C10, 2D5, 2D8, 2D11, 2G1	9202 002098	Zyl. Schr.	12C11, 13M7, 25M10
9120 030082	Rillenkugellager	2G1, 2H2	9202 002118	Zyl. Schr.	12B9, 12C10
9120 050080	Rillenkugellager	31M3, 31H2	9202 002473	Zyl. Schr.	1H10
9120 080110	Rillenkugellager	1C9, 1C11, 1F9, 1F11	9202 002477	Zyl. Schr.	8.4C6, 31E9
9129 016050	Sprengring	1C11, 1D9, 1F9, 1F11	9202 002478	Zyl. Schr.	25G3, 25D10, 25D12, 25.2J2, 25.2K6, 27C10, 25.2D2, 25.2D8, 25.2F6, 25.2F12, 25.1E4, 29J10
9130 103010	Keilriemen	31H9	9202 002487	Zyl. Schr.	11D4, 12D3, 31M11, 31E4, 31D3, 3G9, 25C8, 25H8, 25C6, 25H6
9130 103040	Keilriemen	31H9	9202 002488	Zyl. Schr.	4J5, 5H5, 25.1G3, 29E10, 31B11,
9130 103050	Keilriemen	31H9	9202 002497	Zyl. Schr.	12H7, 31E2
9130 120200	Keilriemen	16.1E6, 16.1G6	9202 002498	Zyl. Schr.	2B2, 12B9, 12J2, 12J3, 12H3, 29B11
9130 120410	Keilriemen	15F10, 16.1D6, 16.1F6, 16.1K6	9202 002507	Zyl. Schr.	31L11, 31E2, 29L6, 11K5
9130 500020	Keilr. Scheibe	15D11	9202 002508	Zyl. Schr.	31C2
9130 500030	Keilr. Scheibe	16.1E4	9202 002517	Zyl. Schr.	8B3, 8B8, 8.2B7, 12H7, 25.2J5, 31B2
9130 500040	Keilr. Scheibe	16.1G4	9202 002518	Zyl. Schr.	30J9
9130 500050	Keilr. Scheibe	16.1H4	9202 002777	Zyl. Schr.	13M9, 25M11
9130 500060	Keilr. Scheibe	16.1D4, 16.1K4	9202 002778	Zyl. Schr.	2D2, 4J6
9130 500070	Keilr. Scheibe	16.1F4	9202 002887	Zyl. Schr.	8G12, 8.2J12, 8.4J11, 31M10
9130 500080	Keilr. Scheibe	16.1G4, 16.1H4	9202 002897	Zyl. Schr.	11C10, 31K11
9130 500100	Keilr. Scheibe	16.1J4	9202 002898	Zyl. Schr.	1M5, 5D3, 5D11, 5F4, 5J7, 5F10, 11M3, 5H10, 5J10, 5L9, 12H4
9190 400100	Stopfen, Lamellen	1E5, 1.1E5, 9E4, 9E8, 9L8	9202 002908	Zyl. Schr.	1J6, 1J12, 4J5, 4J6, 5B5, 5B11, 7E4, 7D11, 7.1E1, 8F3, 8E9, 5J5, 8.2G8, 8.4H7, 8.5E6
9201 013767	6kt. Schr.	15E7, 16C7			
9201 112857	6kt. Schr.	1M9			
9201 112957	6kt. Schr.	12B4			
9201 113317	6kt. Schr.	8G4			
9201 113338	6kt. Schr.	1L9, 1.1J8			
9201 113767	6kt. Schr.	15D5, 16K3			
9201 113817	6kt. Schr.	31M8			
9201 122867	6kt. Schr.	20M9			
9202 001658	Zyl. Schr.	8A3, 25.2E12			
9202 001653	Zyl. Schr. M3x6	4C4, 4C8, 4C12, 7E2, 7J2, 8.2F12, 25.2D6, 25.2D12, 25.2L10			

Teile-Nr./Part-No.	Benennung/Des.	Tafel/Table	Teile-Nr./Part-No.	Benennung/Des.	Tafel/Table
9202 002917	Zyl. Schr.	25L4, 31B1	9203 003947	Zyl. Schr.	1H10
9202 002927	Zyl. Schr.	25K4	9203 003948	Zyl. Schr.	1J8, 1J11, 5D3, 5D9, 5K8
9202 002937	Zyl. Schr.	27F3, 27H3, 27.1F3 27.1H3, 25.1J10, 25.1L10	9203 003957	Zyl. Schr.	4B4,4B8, 4B11,9B4, 9C5, 9J5
9202 003177	Zyl. Schr.	31K11, 31K7	9203 004057	Zyl. Schr.	29E6
9202 003187	Zyl. Schr.	6G3, 25J5, 25.1C5 9K2, 9K5, 9K7, 9K11, 9M2, 9M5, 9M7, 9M11, 12H1	9203 004277	Zyl.Schr. M6x12	20E7
9202 003307	Zyl. Schr.	25C10, 25D12	9203 123687	Flachkopfschr.	31L2, 31H4, 31J1 31H7, 31K2, 31E9
9202 003317	Zyl. Schr.	25B11, 30B4	9203 211830	li. Senkschr. M2x5	7D1, 7H1, 8.2E11, 25.2D5, 25.2D11
9202 003318	Zyl. Schr.	2B2	9203 213646	Li. Senkschr.	31K3
9202 003737	Zyl. Schr.	1E5, 1.1E5	9203 213657	Li. Senkschr.	20E5
9202 022068	Zyl. Schr.	29G7	9203 312411	Senkschr.	2L1
9202 022078	Zyl.Schr.	6C5, 6C10	9203 313022	Senkschr.	6L11, 6H11
9202 022488	Zyl.Schr.	4E1, 4E5, 4E9	9203 313047	Senkschr.	12B7
9202 042077	Zyl. Schr.	1H1	9203 313647	Senkschr.	7D7, 8.2F5, 11L2, 7.1D4, 8D5, 8E7, 8.5D9, 8.4F5
9202 042087	Zyl. Schr.	4B2, 4B6, 4B10, 29G7	9203 313652	Senkschr.	10C11, 10J11, 10.1E5
9202 042477	Zyl. Schr.	12B2	9203 313657	Senkschr.	3D2, 3D5, 3G2, 3H5, 12C9
9202 042488	Zyl. Schr.	1C4, 1C9, 1F9, 11C3	9203 313667	Senkschr.	1K2, 3D2, 3D5
9202 042487	Zyl. Schr.	1B1, 1.1B1, 10C7, 10C11, 10J11	9203 313677	Senkschr. M6x12	29C4, 15M3
9202 042488	Zyl. Schr.	30H9	9203 313977	Senkschr. M5x12	10D5, 10I5, 10.2K10; 10.2J4
9202 042508	Zyl.Schr.	1B1, 29D1, 1.1B1, 30E7	9203 313997	Senkschr.	31C2
9202 042888	Zyl. Schr.	6B5, 6E4, 31M6	9203 314267	Senkschr.	1.1G3, 1.1H6
9202 100328	Senkschr.	8.4A6, 8.4B7	9203 314277	Senkschr. M6x22	29C2, 15J2
9202 100368	Senkschr.	12B6	9203 314297	Senkschr.	31L6, 31H4
9202 100558	Senkschr.	1.1F8	9203 403670	Zapfenschr.	4E2, 4E6, 4E10
9203 001807	Zyl. Schr.	2K2, 2J9	9204 001767	Senkschr.	3D2, 3D6
9203 002747	Zyl. Schr.	8B5, 8B8, 8.2B6, 8.2B7, 8.4B6	9204 002097	Senkschr.	29K7
9203 003027	Zyl. Schr.	10B11,10H11,10.1C5	9204 002363	Senkschr.	20E9
9203 003028	Zyl. Schr.	7F10, 7.1G3, 8H5, 8H8, 8H9, 8.2K8, 8.2K8	9204 201667	Linsenschr.	3D10, 3J3, 3L3, 25B6, 25F6, 16K5
9203 003037	Zyl. Schr.	25.2E4, 25.2E10, 25.2K4	9204 201827	Linsenkschr.	16J5
9203 003057	Zyl. Schr.	6G1, 6G3, 12D3	9204 211997	Fl.kopfschr.	1.1F12, 1.1G12
9203 003067	Zyl. Schr.	10C5,10C11, 10B17, 10H10,10J11,10.2J5	9205 011021	Gew. Stift	25.2B4, 25.2B10, 25.2H4
9203 003078	Zyl. Schr. M3x12	8C3, 8C9, 29C6, 29E6	9205 023043	Gew. Stift	7E1, 7I1, 8.2F11 25D11, 25.2D5 25.2D11
9203 003107	Zyl. Schr.	9C10	9205 023620	Gew. Stift	8.2G4, 8.5D9
9203 003354	Zyl. Schr. M3,5x8	7B4, 7.1B2, 7B11,8C3, 8C9, 8.2C8, 8.4D6, 8.4D8, 8.5C7	9205 023940	Gew. Stift	8.2J8
9203 003627	Zyl. Schr.	4C1, 4C5, 4C9, 12C1	9205 023620	Gew. Stift	4J11, 7D7, 7.1D4, 8F5, 8F7, 8.4H3, 12A4
9203 003647	Zyl.Schr. M4x6	10J10, 10.1D4, 25D10; 25.2D4, 25.2D10; 25.2E1, 25.2E7, 25.2K1, 25.2J4	9205 023631	Gew. Stift	3E1, 3E5, 3B11, 3D9
9203 003662	Zyl. Schr.	2D4,2D7,2D10,2H1	9205 023920	Gew. Stift	12A4
9203 003667	Zyl. Schr.	14D2	9205 023940	Gew. Stift	7E6, 7.1E3, 8.4J7, 8.5G5, 8F5, 8F9
9203 003677	Zyl. Schr. M4x12	10B4, 10G4	9205 024010	Gew. Stift	7C4, 8.2E6, 7.1C2, 8D5, 8D8, 8.1E6, 8.4E6, 8.5E8
9203 003697	Zyl. Schr. M4x16	10C5, 10I5, 29B8	9205 024868	Gew. Stift	1.1J12
9203 003717	Zyl. Schr.	14C6	9205 101528	Gew. Stift	2L2, 2K1
9203 003737	Zyl. Schr. M4x25	25B2, 14F3, 25A8, 25F9	9205 101868	Gew. Stift	1C4, 1K9, 1.1C3
9203 003757	Zyl. Schr. M4x30	10D3, 10.2J3	9205 101878	Gew. Stift	1.1B9
9203 003767	Zyl. Schr. M4x35	29G1	9205 101918	Gew. Stift	4K7

Teile-Nr./Part-No.	Benennung/Des.	Tafel/Table	Teile-Nr./Part-No.	Benennung/Des.	Tafel/Table
9205 102158	Gew. Stift	1D3, 1.1D3, 4K5, 5K5, 7F6, 7F11, 7.1F3, 8G5, 8G9, 8E1, 8F12, 3E1, 3F5, 8.2H12, 8.2K8, 8.4J5, 8.5G9, 8.4K7, 12E5	9231 110128	6kt. Mutter	1.1G11
			9231 110137	6kt. Mutter	31M8, 31E5
			9234 000067	6kt. Mutter	4K7, 4L6, 10H9, 10.1D3
			9301 101871	Zyl. Stift	12G2
9205 102168	Gew. Stift	2A4, 2A6, 2A7, 2A8, 2A10, 2A12, 10D11, 10L11, 10E9, 10M9, 31J11, 31F5, 31C7, 10.1G5, 10.1H3, 2F1, 2F3	9301 102243	Rgkpf. Zyl. Stift	5K7
			9303 700577	Halbrd.Kerbnagel	10D11, 10K10, 10.1E5
			9305 001680	Spannstift 3x18	31H2
			9305 003270	Spannstift 5x16	31M6
9205 102178	Gew. Stift	4J1	9330 000067	Scheibe	8A3, 8.2B8, 8.4A8, 9B9, 12C9, 12D3, 12A9, 12D9
9205 102188	Gew. Stift	4F2, 4F6, 4F10			
9205 102467	Gew. Stift	1.1A11	9330 000087	Scheibe	1J8, 1J3, 1J4, 1.1D11, 10L4, 11I9, 16J5, 16K5, 10K7, 29D8, 29D11, 29G7, 10C7, 10H9; 10.1D4, 10.2J10, 12D5, 25B6, 25G6
9205 102468	Gew. Stift	1B3, 6L8, 6G8, 1.1B2, 1.1B10			
9205 102478	Gew. Stift	1B12, 1C6, 1C10, 1C12, 4L8, 6K6, 6L9, 6G9, 6G10, 1E12, 1F12, 1F10	9330 000088	Scheibe	3C2, 3C5, 3C10, 5C3, 5C9, 12C3
9205 102488	Gew. Stift	1B11, 1C11, 2C1, 2D1, 4K4, 4L7, 5K1, 1D11, 12C4, 31L4	9330 000097	Scheibe	1K3, 25D12, 29E6, 31F8, 31E2, 8.2C7, 25M11, 1.1M3, 8B3, 8B9, 25.1E4
9205 102578	Gew. Stift	31G2			
9205 102598	Gew. Stift	29M3	9330 000107	Scheibe	1.1H9, 29L2, 31M8, 31K11, 31K8, 31K11, 31B1, 31C4, 31D4, 31G2, 12G4
9205 102783	Gew. Stift	1B9			
9205 102798	Gew. Stift	1C6, 1.1B6, 5J6			
9205 122478	Gew. Stift	1B11, 1E11			
9205 122488	Gew. Stift	1B11, 1E11, 6L5, 6L6	9330 000127	Scheibe	31L9
9205 122498	Gew. Stift	2B1, 2E1, 6K5, 6K12, 6F12	9330 000167	Scheibe	25K4, 27F3, 27G1, 27.1F3, 27.1G1, 25L3, 25.1K8, 25.1K10
9205 122818	Gew. Stift	6L12, 6G12			
9205 161558	Gew. Stift	2C4, 2D7, 2D10, 2H1	9330 200097	Scheibe	1K3
9205 161898	Gew. Stift	11M6	9330 300027	Scheibe	15D5, 16J3
9205 162183	Gew. Stift	12C1	933 900077	Scheibe	9B9
9207 160857	Spanpl. Schr.	20H8	9330 900107	Scheibe	29E6, 29K7, 31L11, 31E2
9207 170227	Spanpl. Schr.	15C4, 15E1, 16G2, 16H1, 16H4, 30G11			
9207 170437	Spanpl. Schr.	29F3, 20F10, 30H2, 16G4, 30G4	9330 900117	Scheibe	20E7, 20F6
9207 170847	Spanpl. Schr.	16J1	9330 900127	Scheibe	25B10, 25D12
9207 170857	Spanpl. Schr.	25A3, 25B8, 26G8, 15J5	9332 500150	Federscheibe	5D6, 5D12, 5J11
9217 000117	Fluegelschr.	12G4	9333 000090	Zahnscheibe	20J8
9217 300518	Linsenschr.	3C2, 3C5, 3C10, 29M4	9333 000110	Zahnscheibe	1.1F9
9217 300528	Linsenschr.	29K4	9333 500137	Faecherscheibe	2D2
9217 301038	Linsenschr.	29F3	9334 001120	Paszscheibe	10D9, 10L9
9225 201240	Seenschr.	3B9	9334 001640	Paszscheibe	12H1
9225 201750	Gew. Bolzen	3D2, 3D6, 3G2, 3H6	9334 002638	Scheibe	1.1H9
9231 000367	6 Kt. Mutter	10C5, 10H5, 2C5, 2C8, 2C11, 2G2	9343 000080	Scheibe	25D10, 25.2D4, 25.2D10, 25.2J4
9231 000377	6kt. Mutter	3A1, 3A6, 3B5, 10B9, 10G9, 10.1B3, 5H8, 10.2J6	9351 000087	Stellring	12A4
9231 000387	6Kt. Mutter	6H12, 6L12, 12H4, 20G6, 29K7, 31K11	9352 000100	Sich. Ring	31E6
9231 000388	6kt. Mutter	5F6, 5F12, 5L10	9352 000200	Sich. Ring	1B10, 1E10
9231 110057	6kt. Mutter M4	1.1E11, 1.1F12, 12B6, 12C9, 25B2, 29B6, 25G3, 25G6, 12C9, 16H5	9352 000220	Sich. Ring	1B11, 1E11, 6F11, 6K11
9231 110058	6kt. Mutter	5C3, 5C9	9352 000060	Sich. Ring	4K11
9231 110107	6kt. Mutter	20L8, 31E2	9353 000198	Sich. Ring	7F4, 7.1F2, 8.2J6, 8G5, 8G8, 8.4J5, 8.5G9, 8F10
9231 110127	6kt. Mutter	29M3, 31K8, 31G2, 31M8, 31M10, 31C4	9357 000050	Sich. Scheibe	8F1, 8H10, 8.2K10, 8.4K10, 10.2K1, 10E11
			9357 000060	Sich. Scheibe	1H9, 6C11, 3C9, 8D2, 8D3, 8G7, 8G10, 8.2H9, 7.1D2, 8.2J9, 8.2F8, 8.4J9, 8.4G7, 8.5D7

Teile-Nr./Part-No.	Benennung/Des.	Tafel/Table	Teile-Nr./Part-No.	Benennung/Des.	Tafel/Table
9357 000070	Sich. Scheibe	1.1H9, 1.1M3 1.1M4, 1.1C12, 5C1, 5C7, 5H6, 6A4, 6J8, 6J9, 10D9, 27A7,	9792 001030	Reduziernippel	25.2E5, 25.2E11, 25.2L5
9357 000090	Sich. Scheibe	1C6, 5G7, 1.1C6, 12A6, 12C5, 31K3,	9792 051020	Muffe	25.1M8, 27H1, 27.1H1
9357 000100	Sich. Scheibe	1K6, 1M6	9792 071010	Blindstopfen	29E12, 3G10, 25D8, 25J8, 25G3, 25.2L6
9357 000198			9792 102000	Wi-Stueck	1F4, 1.1F4 25.1D7, 25.1L7, 27E3, 27.1E3
9357 200002	Winkelgelenk	5J10, 5L10	9792 301010	Dichtring	25.2F5, 25.2G11, 25.2L5
9380 510120	Tellerfeder	7.1F2, 8G3, 8G9, 8.2J8, 8.4J7	9792 301020	Dichtring	25M3
9400 211020	Kugelpopf	12C7	9800 120009 A	Naehantrieb	16A5
9700 001020	Zylinder, einf.	25E10, 25H12, 25L3, 27C2, 27.1C2, 25.1J4	9800 120017 A	Naehantrieb	16C7
9700 100052	Zylinder, einf.	25D10, 27C7, 25.1D2	9800 130014 R	Naehantrieb	15F10
9700 200840	Zylinder, Doppel	31B6	9800 310006	Motorfuss	15B7, 16B7
9710 061110	Magnetventil- 3/2 Wege	25J2, 25F3, 29L9, 27D10, 31C10, 3J9, 25.2F6, 25.2F12, 25.2G5, 25.2G11, 25.2L6	9800 310007	Riemenschutz	16A10
9710 920120	Ventil, Drossel	29E10, 5F4, 27D3, 25F3, 27C9, 27.1D3 25D6, 25J2, 25J6, 25.2E5, 25.2E11 25.1C7, 25.1K7	9800 321009	Steuerkasten	16H9
9710 981010	Schalldaempfer	29L9, 25F3, 27D2, 27D10, 27.1D2, 3J9, 31C10, 25E6, 25J2, 25K6, 25.2G5, 25.2G11, 25.1A6, 25.1H5	9800 327001	Positionsgeber	16D10
9731 002001	Schlauch	27K2	9800 330001	Ext. Betaetigung	15H8, 16C6
9731 005004	Schlauch	25F2, 29F10, 29J10, 27D9, 31B7, 31B11, 3J9, 25D6, 25H6, 25H1, 25H12, 25L4 25L10, 27.1B2	9800 330002	Schalter, Netz	15J5
9731 006004	Schlauch, pur	3F9, 25C6, 25H6, 25L4, 25J2, 25.1B7, 25.1H6, 25.1J6, 25.1J11	9800 330009	Bedienfeld	15F3, 16A3
9740 001215	O-Ring	4B2, 4B6, 4B10	9800 330010	Bedienfeld	15G4, 16B3
9740 010020	O-Ring	7.1E2, 8.2H6, 8.4J5, 8.5G7	9800 330011	Adapter	15G10, 16E5
9740 003804	O-Ring	7.1E4, 8F5, 8F7, 8.4H5, 8.5F9	9800 331014	Steuerkasten	15G9
9742 300195	Lippenring	1.1L1, 1.1L6	9800 331015	Nähantrieb	15D7
9781 000002	Filterregler	27M9	9810 390402	Potentiometer	4K11
9790 000400	Stecknippel	3G9, 25E4, 27C10, 25G3, 25.2E5, 25.2E11, 31B12, 25.2F6, 25.2F12; 25.2K5	9815 301081	Tastenkopf, bedr.	3K12
9790 010010	Verbindg. Wi-N	1.1L1, 1.1H5	9815 590025	Schalter, Schutz	16L6
9790 020010	T-Verb. Stueck	4H4, 5G3, 5H4, 11G5	9815 590026	Schalter, Schutz	16L6
9790 201000	Verschr. Wi-E	25L11	9815 740020	Fadensensor K	25.3G7
9790 201001	Verschr. Wi-E	25E3, 27F3, 27D8, 27.1F3, 31B11, 3H9 25D6, 25J6, 25G1, 25D10, 25H12, 27.1D3	9815 920006	Lichtschranke	29G6
9790 315002	Schlauchtuelle	25.2J6	9815 920007	Lichtschranke K	29C6, 29E6
9790 315103	Schlauchtuelle	25.2C6, 25.2C12, 25.2H5	9815 920016	Lichtschranke K	29C6
9790 315104	Schlauchtuelle	3D11	9815 925002	Lichtschranke	25.2B5, 25.2B11, 25.2H4
			9820 110009	Hubmagnet	3K1, 3L3
			9822 510001	Naehleuchte	30A2
			9822 510012	Glasscheibe	30D1
			9822 510125	Naehleuchte	29B2
			9822 510127	Lichtleiter (420mm)	29C2
			9822 560000	Nähleuchte LED	30G8
			9822 560001	Netzteil	30J8
			9822 642023	Halogenlampe	27B1
			9822 642024	Halogenlampe	30C1
			9825 151001	Stecker 10 pol.	27E5
			9825 151604	Messerkontakt	10M5
			9825 173700	Stiftleiste	25.1C10
			9825 180302	Kabelkopf, gross	29E12,
			9825 190400	Stecker	16M9
			9825 190502	Stecker	16K9
			9825 551102	Steckverbinder	10D5, 10.2J5, 9C10
			9825 810302	Sicherung	25.2G6, 25.2G12, 29F2, 30H4
			9825 810319	Sicherung	15J7
			9825 810412	Sicherung	15J7
			9830 501010	Distanzhalter	25D4, 25C8, 25C8, 25H8
			9830 515038	Erdungsblech	20F10
			9830 520004	ISO-Platte	9B10
			9840 102062	Kabelschuh, Ring	20K7, 20K9, 20L9
			9840 104001	Flachst. Huelse	30E3, 29E2

Teile-Nr./Part-No.	Benennung/Des.	Tafel/Table	Teile-Nr./Part-No.	Benennung/Des.	Tafel/Table
9840 104204	Flachst. Huelse	20K7	9870 767005	Leitung K	25C2, 25G6
9840 104212	Schutzhuelse	27E4	9870 767011	Nähleuchte 1-LED	30A7
9840 111003	Flachst. H-Band	25G3, 25G4, 25G6 29F12	9870 767017	Leitung K	27.1B5
9840 111004	Flachst. H.-Band	27E4	9870 767018	Leitungssatz K	20J10, 20L10
9840 120001	Nagelschelle	15B4, 16G4	9870 767028	Leitung K	10.2L8, 10.2M8
9840 120003	Nagelschelle	27M8, 30F2, 20L8, 29E1	9870 767029	Leitung K	25B6, 25C1, 25G6
9840 120025	Bef. Schelle	25.2D4, 25.2D10 25.2E1, 25.2E7, 25.2J3, 25.2K1, 20L10	9880 001003	Bef. Teile K	15F3
9840 120026	Bef. Schelle	25.2D3, 25.2D9	9880 002001	Knieschalter K	25M1
9840 120029	Bef. Schelle	25C2, 25B6, 25G6	9880 467004	Taster K	25.1H9
9840 120060	Zugentl. Schelle	15D1, 16G1	9880 767001	Anbausatz K (fuer Lichtl.Naehl.)	29E1
9840 120103	Kabelhalter	20E5	9880 767003	Taster K	25E2
9840 121001	Kabelbinder	10C3, 10I5, 15G4, 25B2, 29F6, 30F5, 29D1	9880 767004	Potentiometer K	4K11
9840 121002	Kabelbinder	9M1, 9M4, M10	9880 767005	Taster K	31E11, 31C12
9840 123002	Stahlnadel	20L8, 27L8	9880 767006	Erdungssatz K	20G9
9840 123003	Stahlnadel	15B4, 16G4, 29E1, 30F2	9880 767010	Taster K	25C6, 25G6
9840 133001	Wuergenippel	29F4, 30F5	9889 076730 1	Antriebspaket	16.1D3
9840 133004	Wuergenippel	16K6, 20M11	9889 076730 2	Antriebspaket	16.1D3
9840 135001	Gegenmutter	29F4, 30G5	9889 076730 3	Antriebspaket	16.1E3
9840 136002	Verschl. Stopfen	10C11, 10J11, 10.1E5	9889 076731 1	Antriebspaket	16.1F3
9840 301052	Leitung	27D11	9889 076731 2	Antriebspaket	16.1F3
9840 301150	Leitung	20K7, 20L9	9889 076731 3	Antriebspaket	16.1G3
9840 302003	Leitung	25.1C11, 25.1E12	9889 076732 1	Antriebspaket	16.1G3
9840 302005	Leitung	29E2, 29F12, 30E3	9889 076732 2	Antriebspaket	16.1H3
9840 303002	Leitung	4J11, 25.1E12	9889 076732 3	Antriebspaket	16.1H3
9840 304003	Leitung	25.2C3, 25.2C9, 25.2F1, 25.2E11 25.2H1, 25.2H3	9889 076733 1	Antriebspaket	16.1J3
9840 307003	Leitung	25.1E10	9889 076733 2	Antriebspaket	16.1J3
9850 767001	Steuerung K	25.2F1, 25.2F7, 25.2L1	9889 076733 3	Antriebspaket	16.1K3
9850 767002	Leiterplatte K	25.2D4, 25.2D10, 25.2J4			
9850 767004	Verteilung K	10B5, 10G5			
9850 767006	Leiterplatte	14D6, 14E9			
9850 767010	Leiterplatte K	25B4, 25A9, 25H8			
9850 767012	Verteilung K	10.2L7, 10.2M7, 14B2			
9850 767013	Leiterplatte K	25C8			
9850 767015	Leiterplatte K	25.3G8			
9870 001024	Leitungssatz K	16J10, 16.1D8, 16.1F8, 16.1G8, 16.1J6			
9870 001025	Leitungssatz K	16L10, 16.1D9, 16.1E9, 16.1F9 16.1G9, 16.1H9, 16.1J9, 16.1K9			
9870 001104	Leitung K	20L9			
9870 001105	Leitung K	25G4, 25G6, 25G3, 25J2, 27D11, 25D8, 25J8			
9870 001108	Leitung K	20J7			
9870 001112	Leitung K	27L8			
9870 467004	Leitung K	25.1C12			
9870 767001	Leitung K	25.2E5, 25.2F12, 25.2L1			
9870 767002	Leitungssatz K	25.2C3, 25.2C9, 25.2H3			



Befestigungsteile für Näheinrichtungen
Fastening parts for Sewing equipment

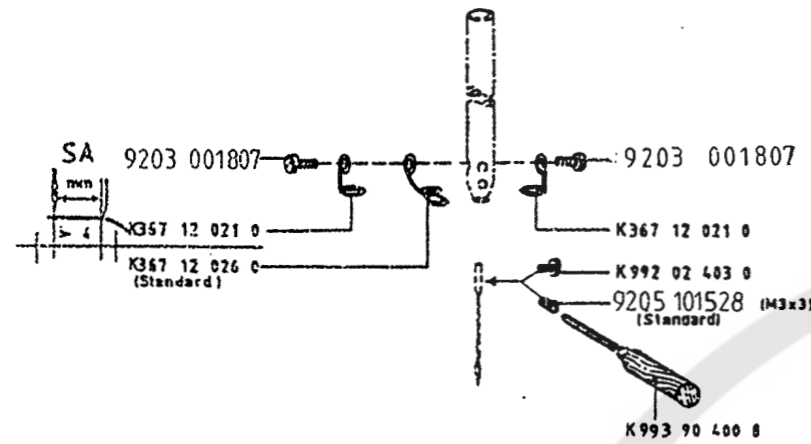

Kombinationen

1		
K367 12 021 0		
K367 12 026 0		

Ausführung M3,5
Style M3,5



Ausführung M3
Style M3

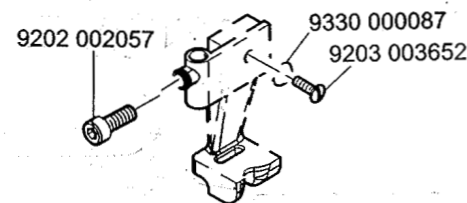
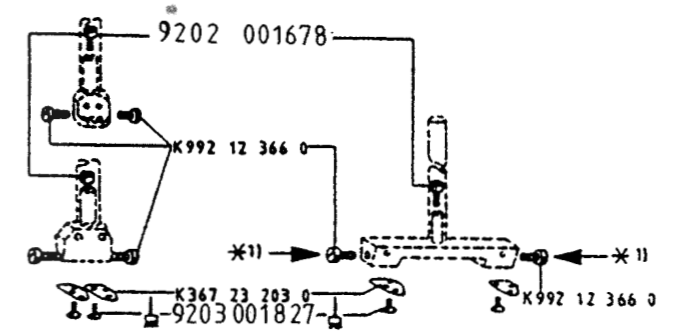

NA	1	
4	K367 23 211 4	K367 23 211 0
5	K367 23 212 4	K367 23 212 0
6	K367 23 209 4	K367 23 209 0
8	K367 23 204 4	K367 23 204 0
10	K367 23 202 4	K367 23 202 0
12	K367 23 205 4	K367 23 205 0

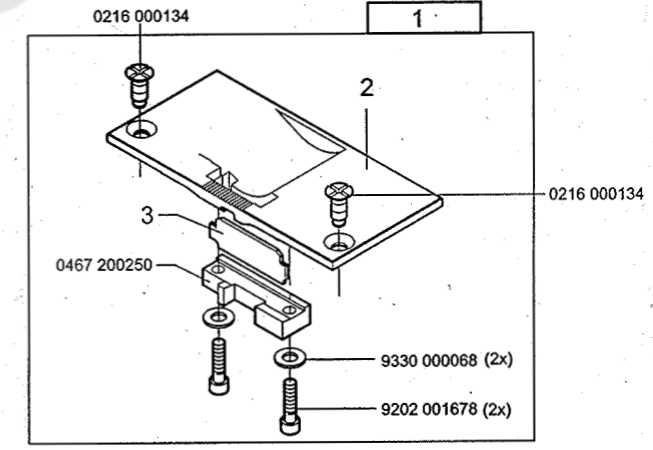
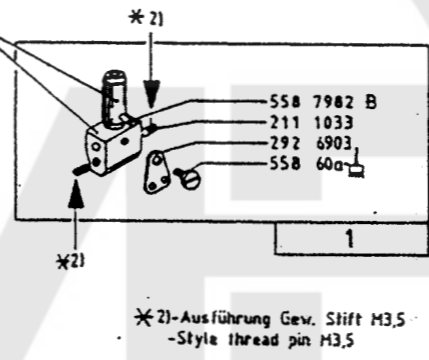

E...	1	2	3
E31/3	0467 200534	0467 200530	0467 200520
E31/5	0467 200234	0467 200230	0467 200220
E31/8	0467 200244	0467 200240	0467 200220

NA	2	
14	K367 23 215 4	492 107012
16	K367 23 216 4	492 107019
18	K367 23 220 4	492 107022
20	K367 23 218 4	492 107024
22	K367 23 214 4	492 107026
24	K367 23 217 4	492 107028
26	K367 23 221 4	492 107030
28	K367 23 231 4	492 107032
30	K367 23 219 4	492 107034
32	K367 23 213 4	492 107036
34	K367 23 235 4	492 107038
36	K367 23 230 4	492 107040
38	K367 23 234 4	492 107042
40	K367 23 224 4	492 107044

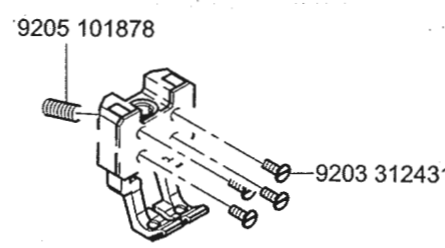
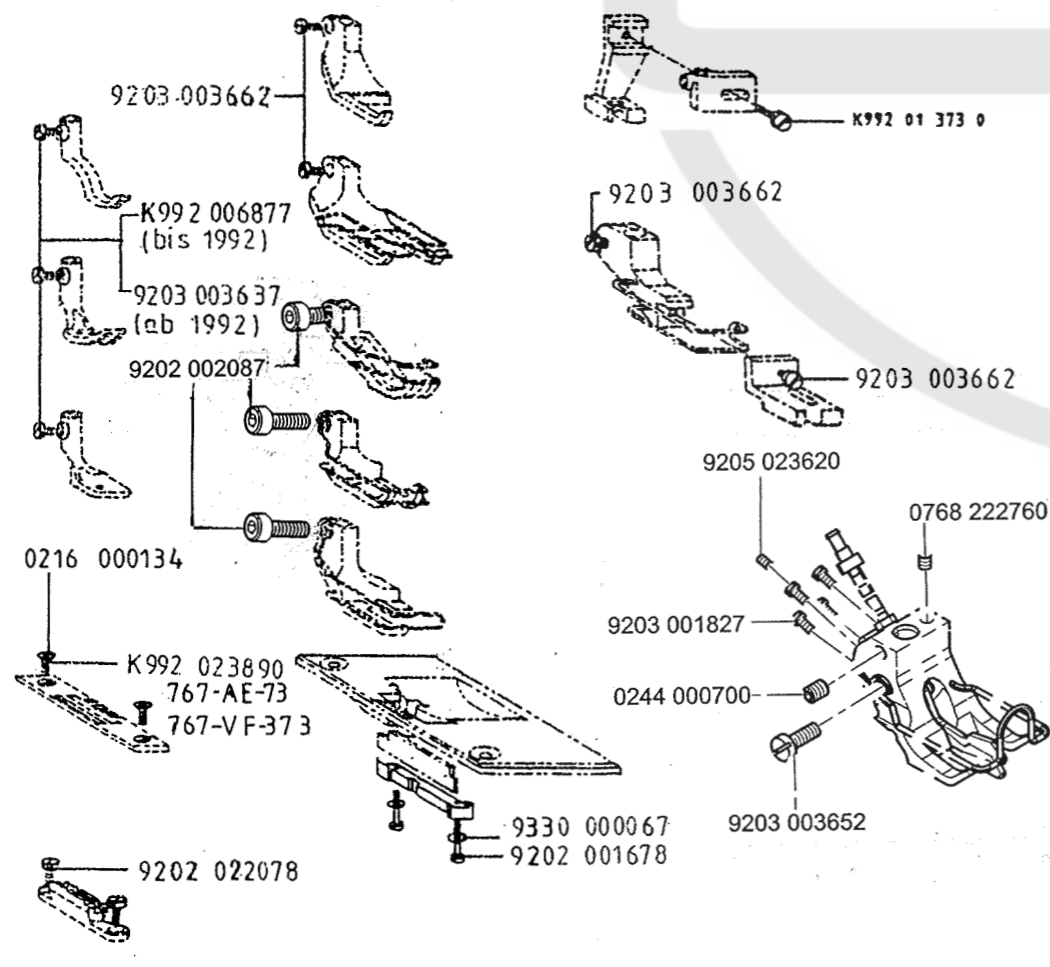
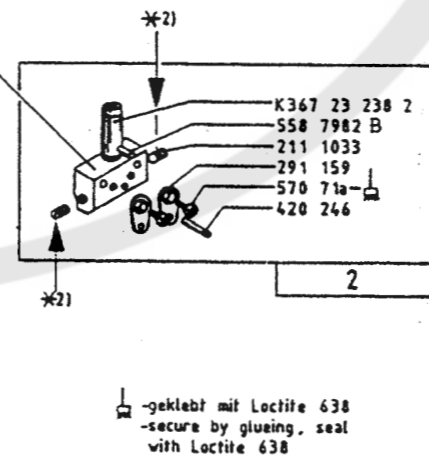



E1
E201

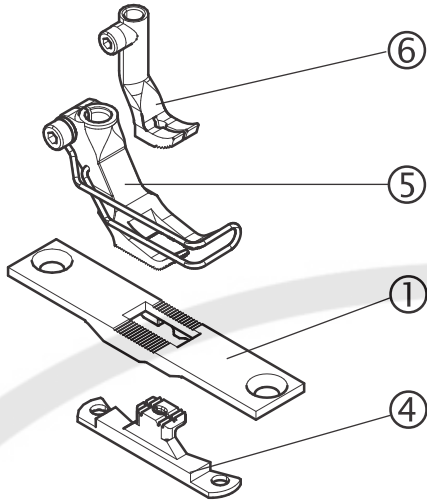

E2
E202

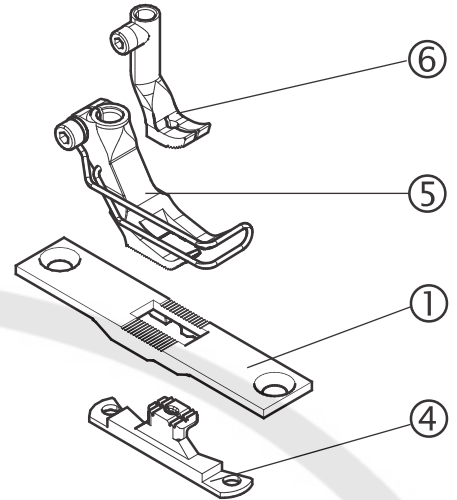

E5
E205

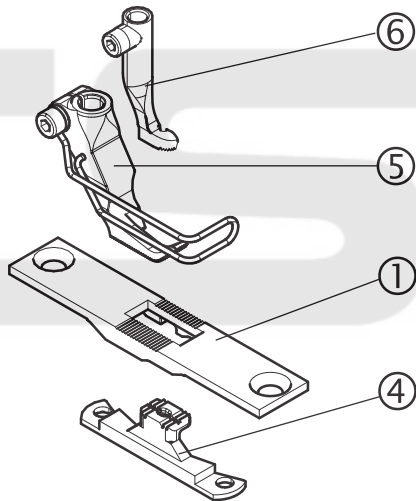

E7
E207

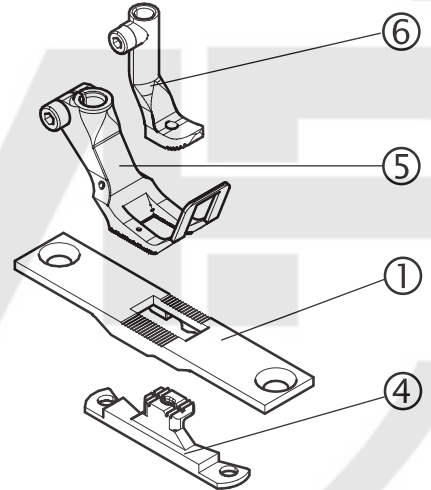

E15
E215

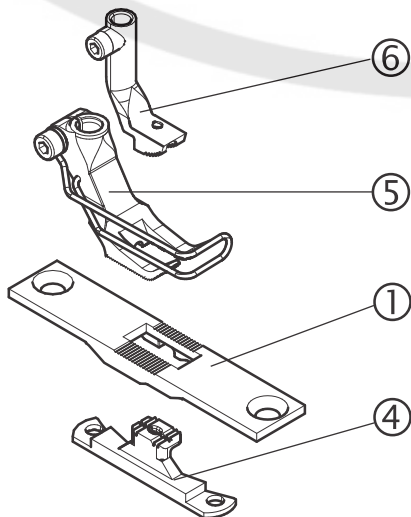

E16
E216

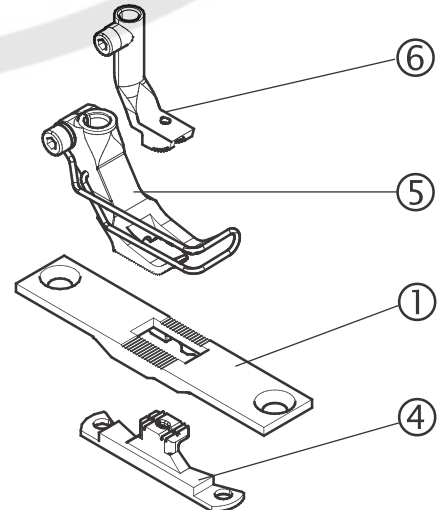



E17
E217

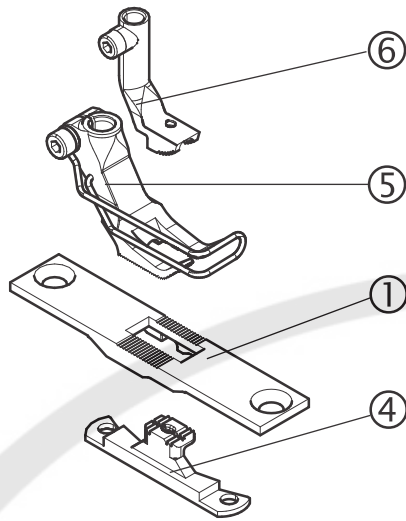

E18
E218

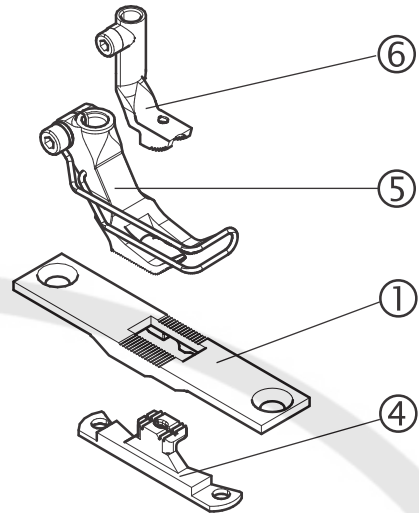

E19
E219

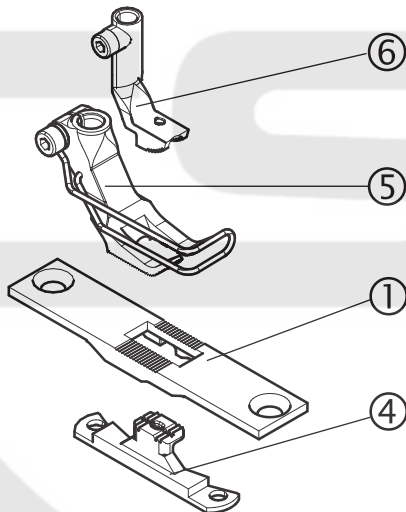

E20
E220

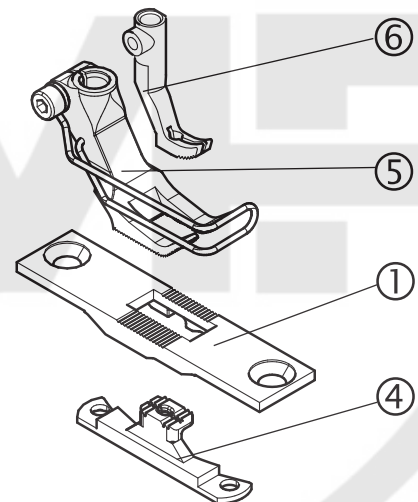

E21/5

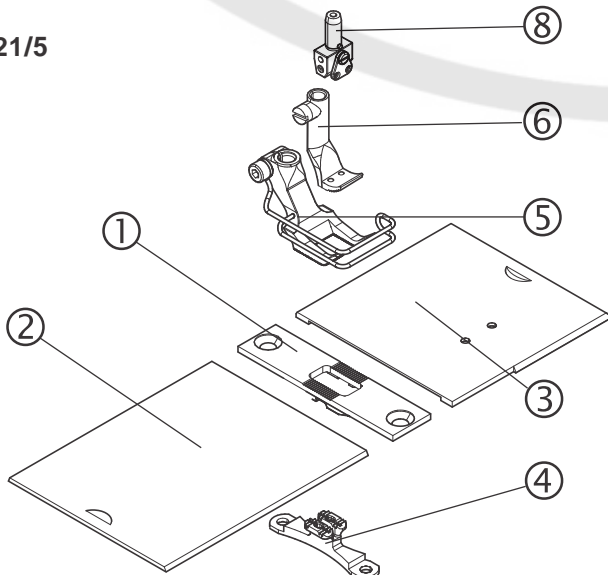

E21/6

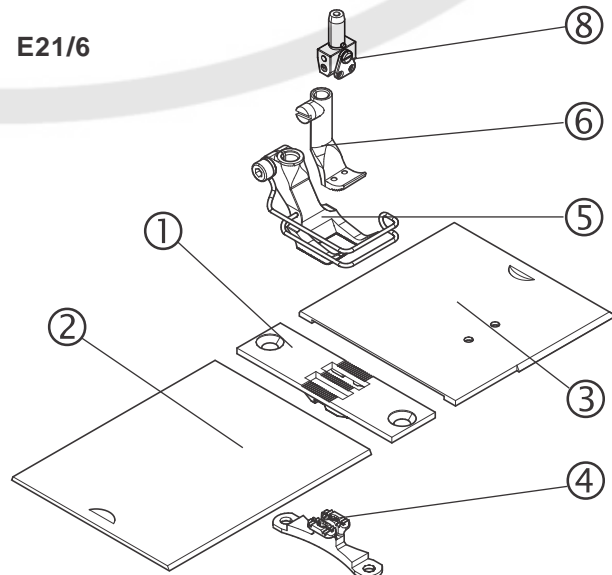



E21/8

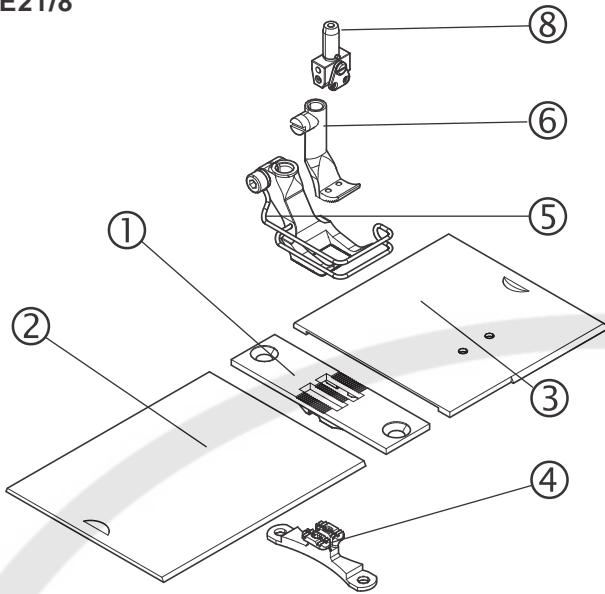

E21/10

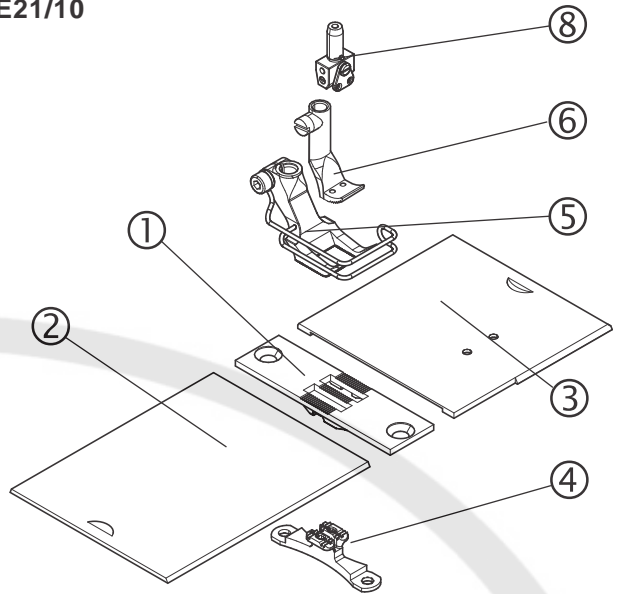

E21/12

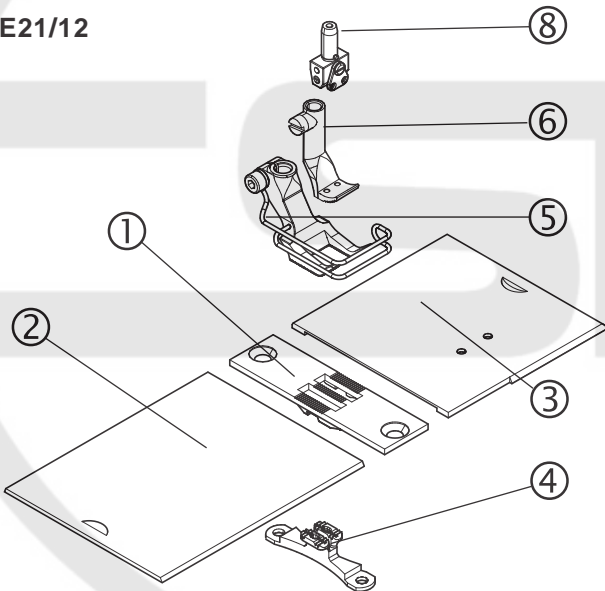

E21/14

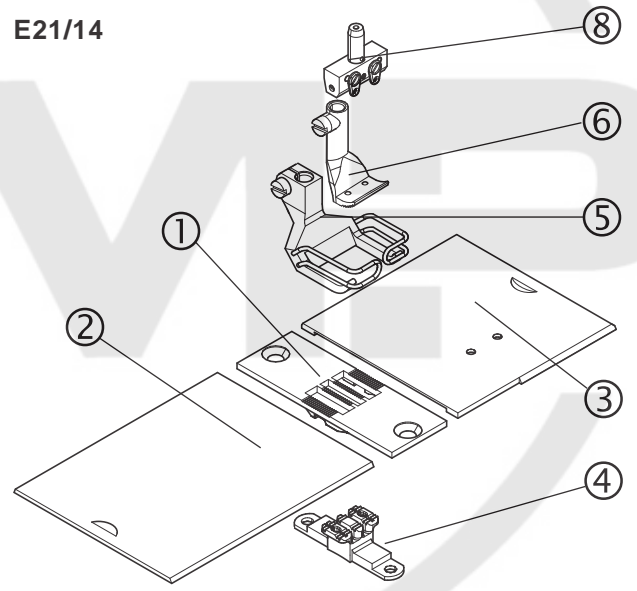

E21/16

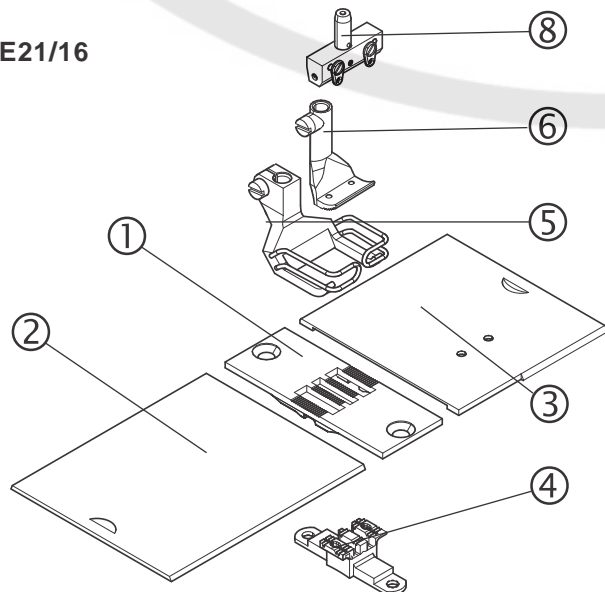

E21/18

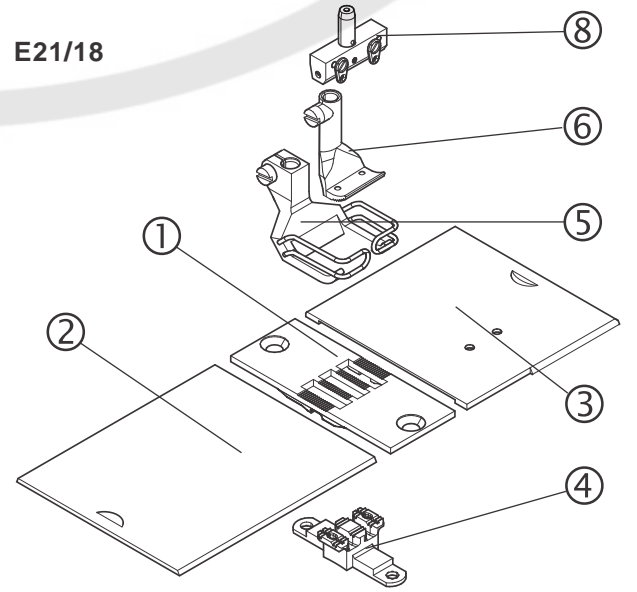



E21/20

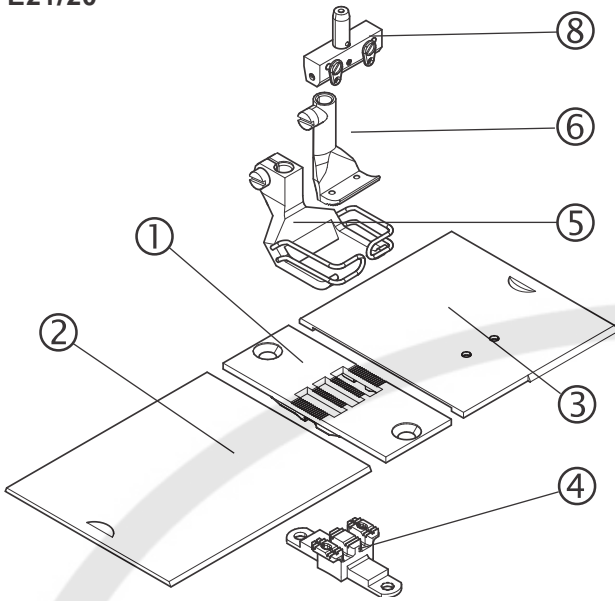

E21/22

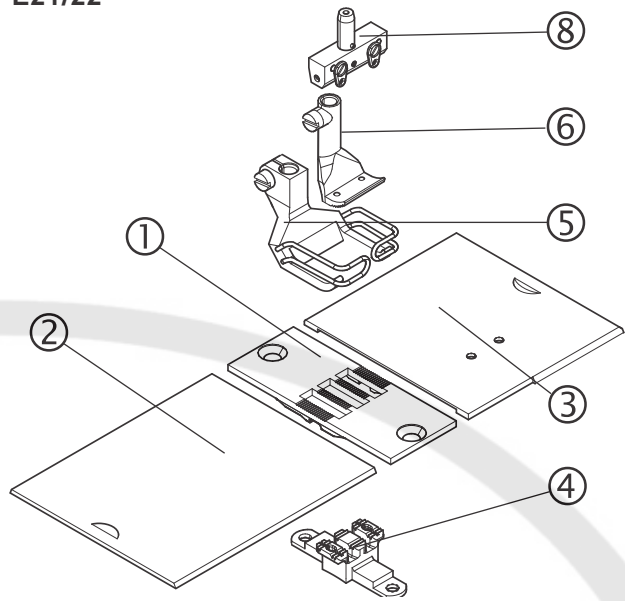

E22/8

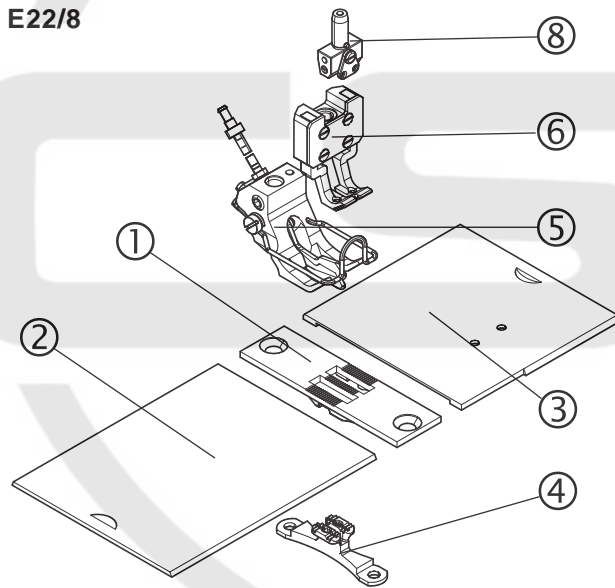

E22/10

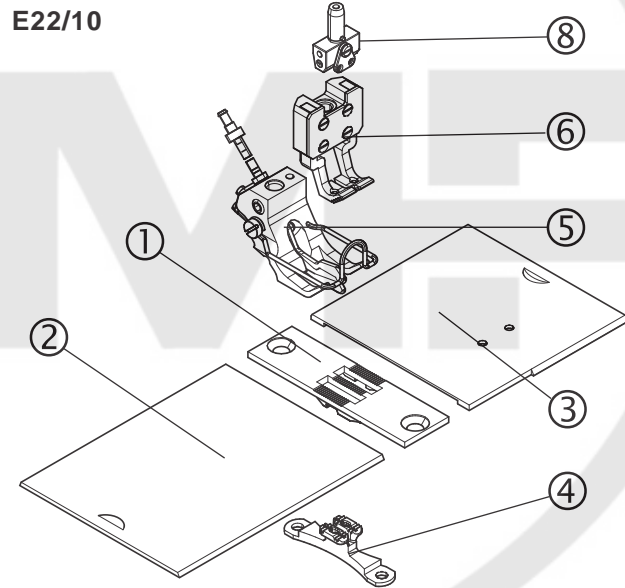

E25
E225

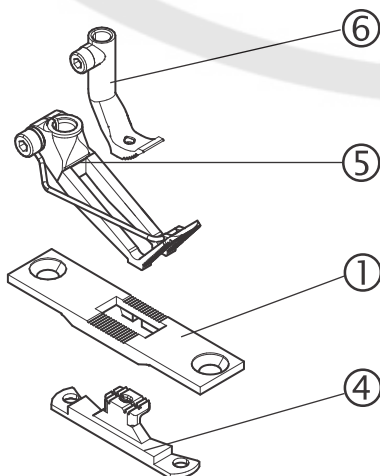

E29

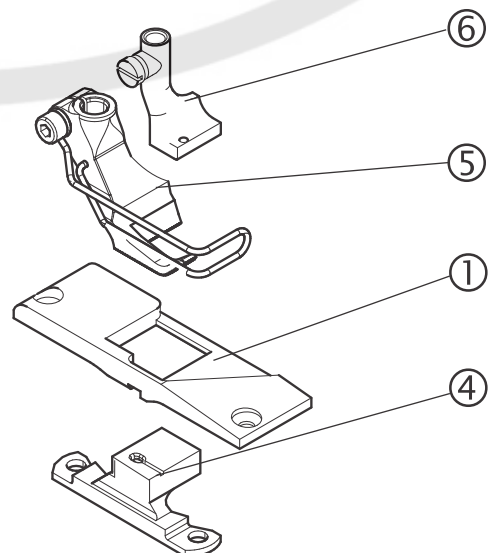



E31/3

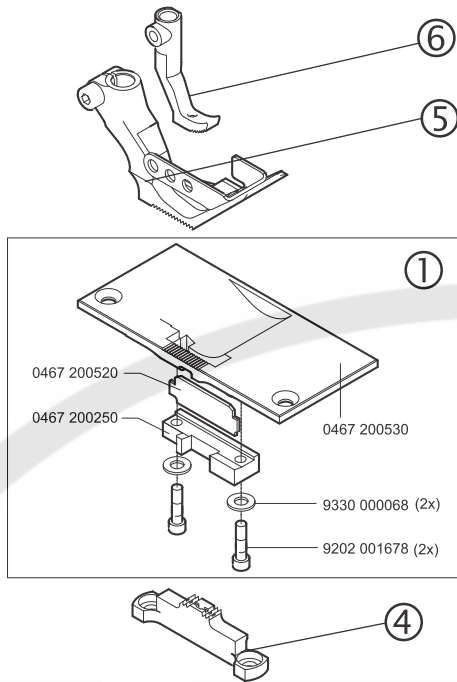

E31/5

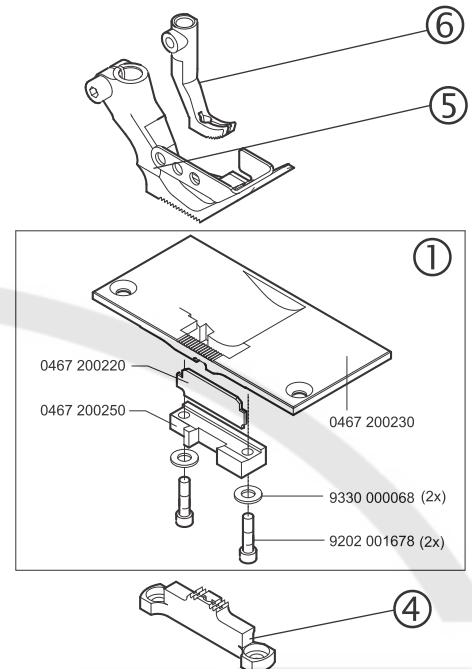

E31/8

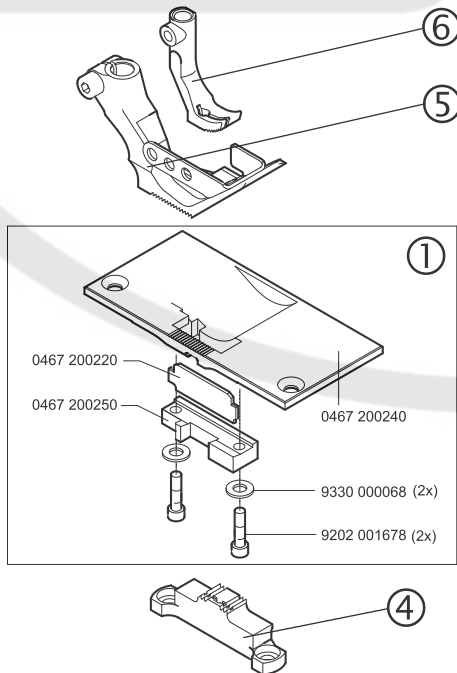

E46

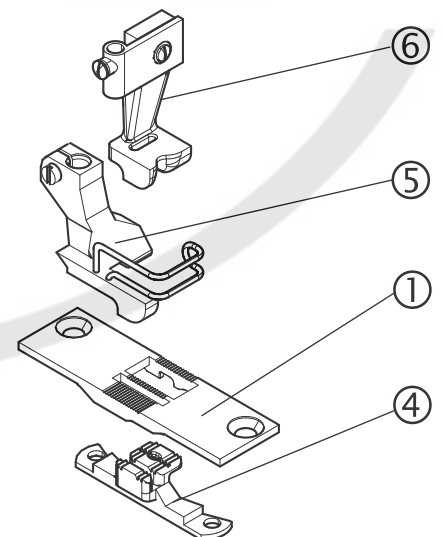



E64

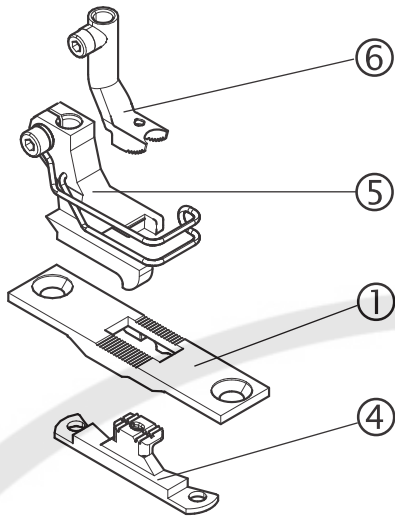

E65

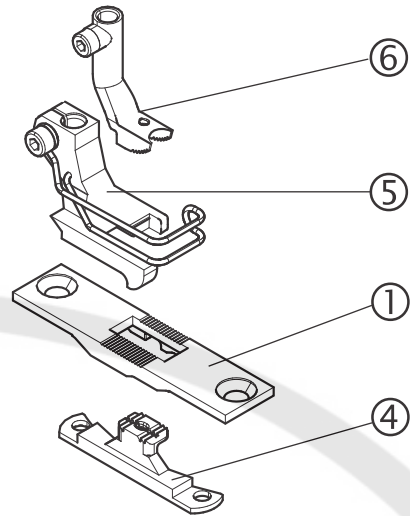

E66/10

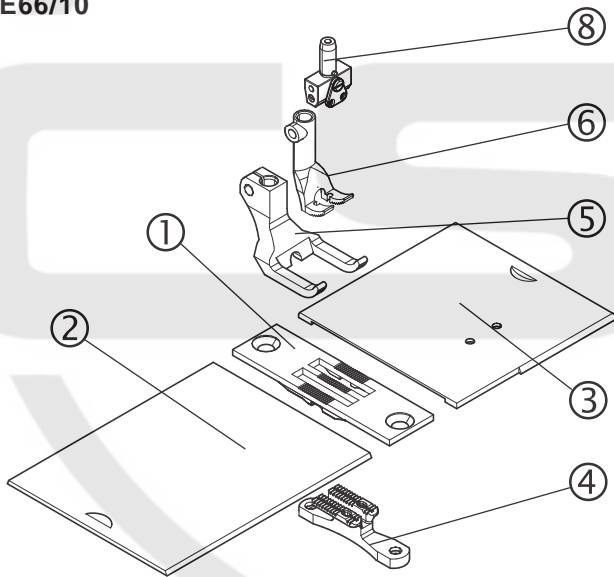

E66/12

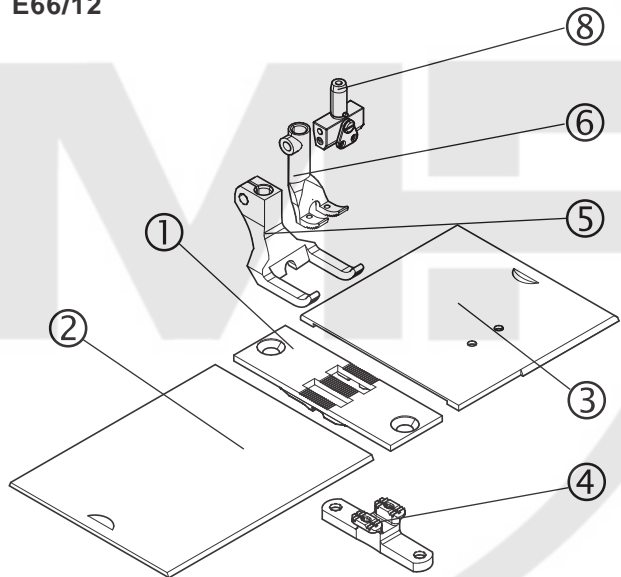

E69

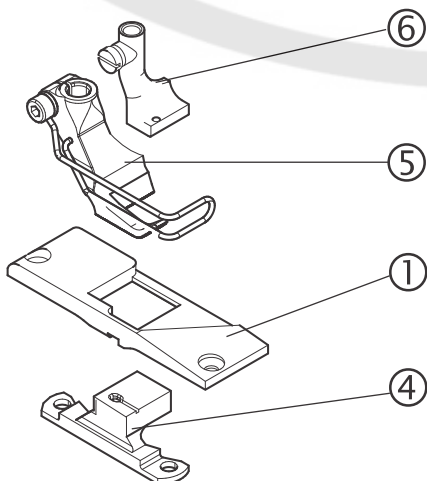

E74/8

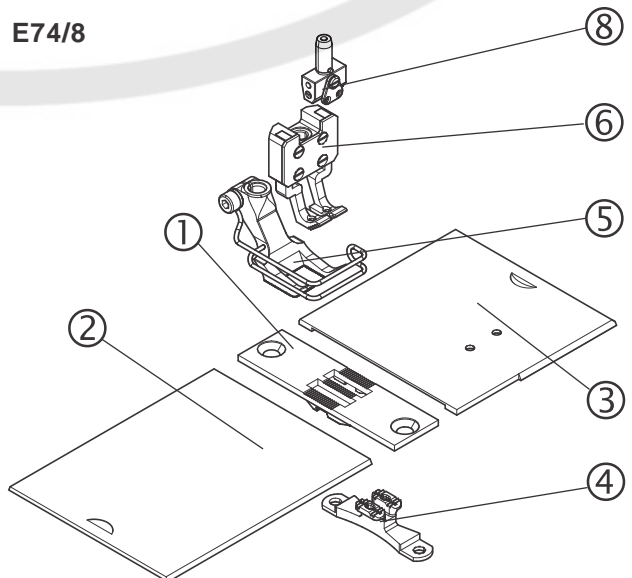



E74/10

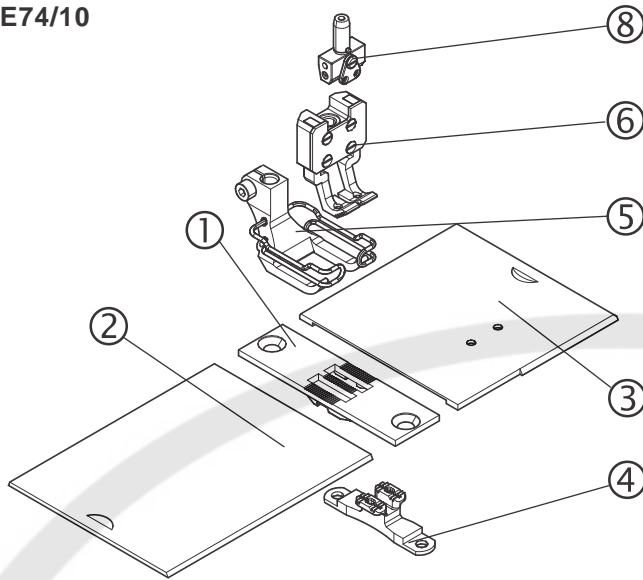

E80

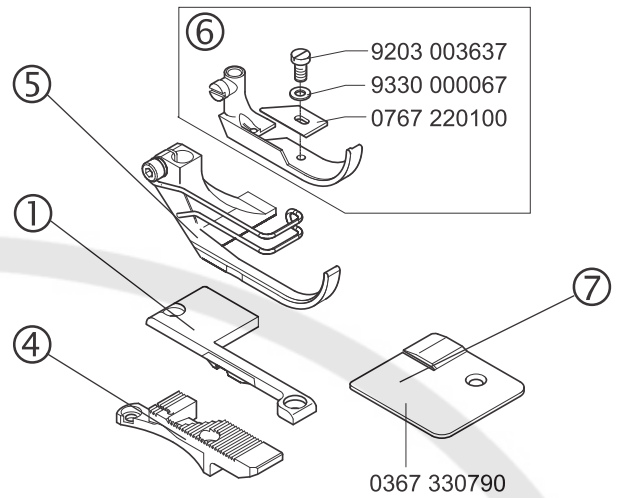

E81

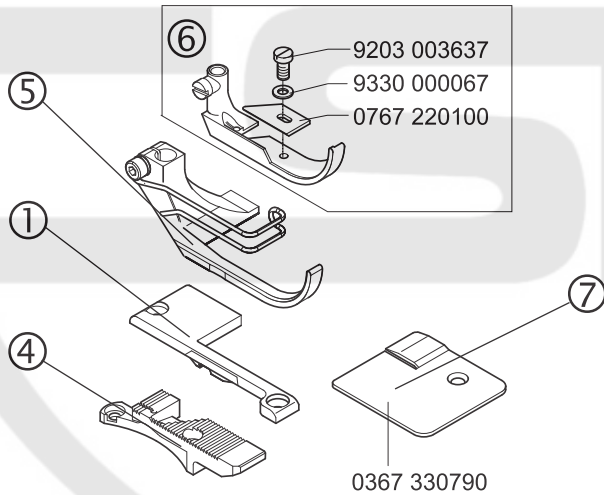

E82

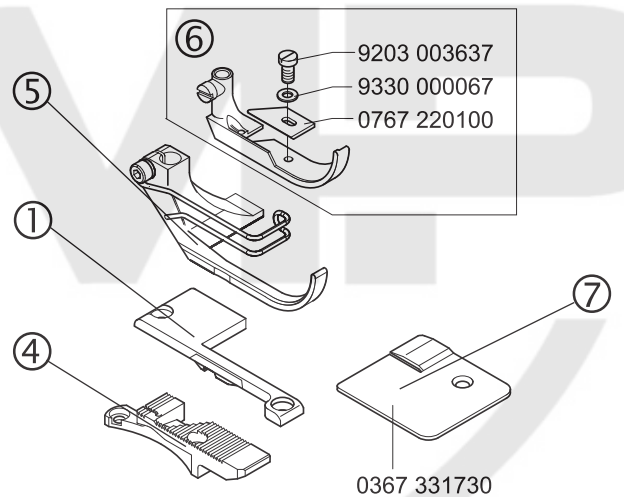

E101

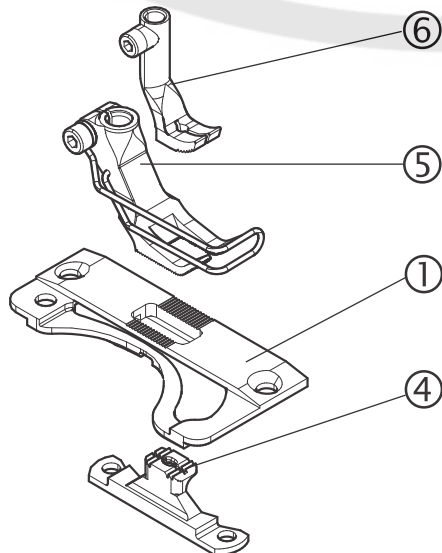

E102

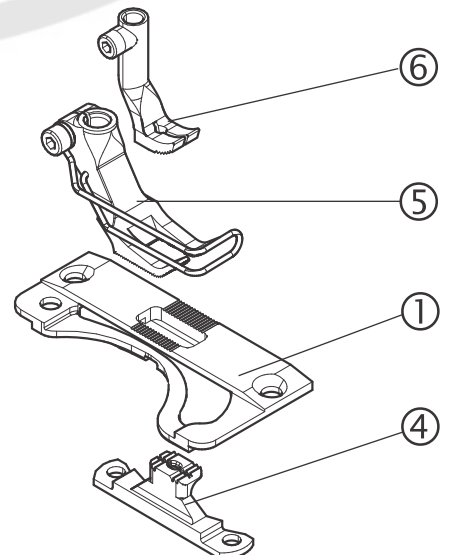



E103

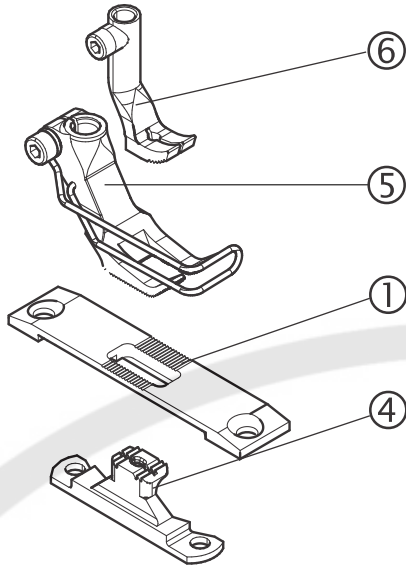

E104

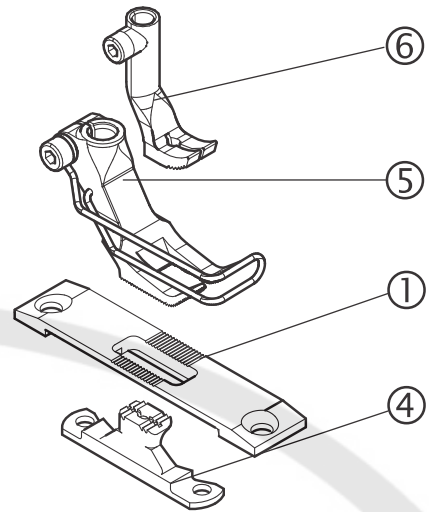

E264

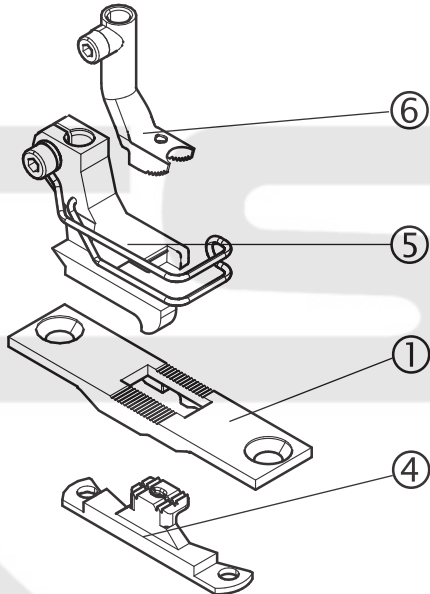

E265

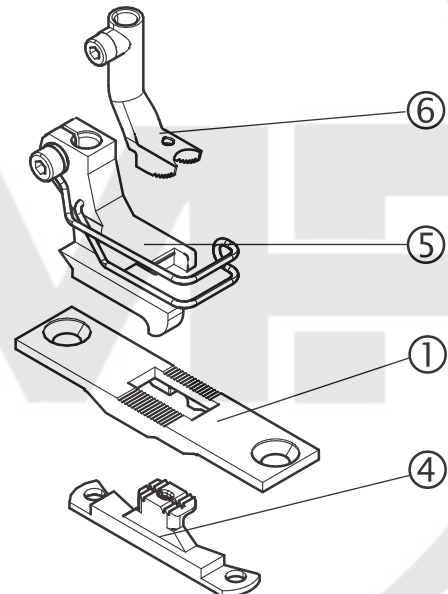



E-Nr. E-No.	Für Unterklasse / For Subclass	Stichplatte Throat plate			Transporteur ④ Feed dog				Presserfuß ⑤ Presser foot			Transp. Fuß ⑥ Feeding foot		⑧ Nadelhalter/Needle holder	Nadelsystem/-dicke / Needle system/-size	
		① Stichplatte / Throat plate	② Schieber, links / Slide, left	③ Schieber, rechts / Slide, right	Stichlochgröße / Stitch hole size mm	Sägeverzahn / Serrated mm	Säge-schrägverzahn / Serrated, oblique mm	Kreuzverzahn / Cross toothed mm	Dachverzahn / Roof-shaped mm	Drückerfuß / Presser foot	Sägeverzahn / Serrated mm	Unverzahn / Non toothed	Hüpfersfuß, kreuzverz. / Skipping f., cross toothed			Ausgleichfuß / Compensating foot
Abb.-Nr. Fig.No.	Verwendungszweck / Use															
E1	-FA-373-RAP-HP; -FAS-373-RAP-HP; -373 Allgemeine Näharbeiten in mittelschwerem Nähgut. Stichlänge max. 6 mm. General stitching operation in medium weight material. Max. stitch length 6 mm.	0467 200090			2,2 x 3,2	0467 210070; 1,4						0367 220993; 0,8		0467 220013		134-35 / 120
E2	-FA-373-RAP-HP; -FAS-373-RAP-HP; -373 Allgemeine Näharbeiten in mittelschwerem Nähgut. Stichlänge max. 9 mm. General stitching operation in medium weight material. Max. stitch length 9 mm.	0467 200020			2,2 x 3,2	0467 210070; 1,4						0467 220043; 0,8		0467 220013		134-35 / 120
E5	-FA-373-RAP-HP; -FAS-373-RAP-HP; -373 Kantensteppen ab 1 mm für mittelschweres Nähgut. Stichlänge max. 6 mm. Topstitching margin 1 mm and more for medium weight material. Max. stitch length 6 mm.	0467 200090			2,2 x 3,2	0467 210070; 1,4						0367 220299; 0,8		0067 220713		134-35 / 120
E7	-FA-373-RAP-HP; -FAS-373-RAP-HP; -373 Allgemeine Näharbeiten in mittelschwerem Nähgut. Stichlänge max. 6 mm. General stitching operation in medium weight material. Max. stitch length 6 mm.	0467 200090			2,2 x 3,2	0467 210070; 1,4						0367 221543; 0,8		0367 221553		134-35 / 120
E15	-FA-373-RAP-HP; -FAS-373-RAP-HP; -373 Kedararbeiten, <u>Kedernut 4 mm</u> breit, links der nadel. Stichlänge max. 6 mm. Piping operations, <u>piping groove 4 mm</u> wide, to the left of the needle. Max. stitch length 6 mm.	0467 200090			2,2 x 3,2	0467 210070; 1,4						0367 220773; 0,8		0167 220583		134-35 / 120
E16	-FA-373-RAP-HP; -FAS-373-RAP-HP; -373 Kedararbeiten, <u>Kedernut 5 mm</u> breit, links der nadel. Stichlänge max. 6 mm. Piping operations, <u>piping groove 5 mm</u> wide, to the left of the needle. Max. stitch length 6 mm.	0467 200090			2,2 x 3,2	0467 210070; 1,4						0367 220783; 0,8		0167 220603		134-35 / 120



E-Nr. E-No.	Für Unterklasse / For Subclass	Abb.-Nr. Fig.No.	Verwendungszweck / Use	Stichplatte Throat plate			Transporteur ④ Feed dog				Presserfuß ⑤ Presser foot			Transp.Fuß ⑥ Feeding foot					
				① Stichplatte / Throat plate	② Schieber, links / Slide, left	③ Schieber, rechts / Slide, right	Stichlochgröße / Stich hole size mm	Sägeverzahn / Serrated mm	Säge-schrägverzahn / Serrated, oblique mm	Kreuzverzahn / Cross toothed mm	Dachverzahn / Roof-shaped mm	Drückenfuß / Presser foot	Sägeverzahn, Serrated	Unverzahn / Non toothed	Hüpfenfuß, kreuzverz. / Skipping f., cross toothed	Kreuzverzahn / Cross toothed	Sägeverzahn / Serrated	Unverzahn / Non toothed	Nadelabstand / Needle distance
E17	-FA-373-RAP-HP; -FAS-373-RAP-HP; -373 Kederarbeiten, <u>Kedernut 6 mm</u> breit, links der nadel. Stichlänge max. 6 mm. Piping operations, <u>piping groove 6 mm</u> wide, to the left of the needle. Max. stitch length 6 mm.			0467 200090			2,2 x 3,2	0467 210070; 1,4					0367 220793; 0,8			0167 220363			134-35 / 120
E18	-FA-373-RAP-HP; -FAS-373-RAP-HP; -373 Kederarbeiten, <u>Kedernut 7 mm</u> breit, links der nadel. Stichlänge max. 6 mm. Piping operations, <u>piping groove 7 mm</u> wide, to the left of the needle. Max. stitch length 6 mm.			0467 200090			2,2 x 3,2	0467 210070; 1,4					0367 220803; 0,8			0167 220633			134-35 / 120
E19	-FA-373-RAP-HP; -FAS-373-RAP-HP; -373 Kederarbeiten, <u>Kedernut 8 mm</u> breit, links der nadel. Stichlänge max. 6 mm. Piping operations, <u>piping groove 8 mm</u> wide, to the left of the needle. Max. stitch length 6 mm.			0467 200090			2,2 x 3,2	0467 210070; 1,4					0367 220813; 0,8			0167 220653			134-35 / 120
E20	-FA-373-RAP-HP; -FAS-373-RAP-HP; -373 Für allgemeine Näharbeiten - spezielle Ausführung für DA-USA. Stichlänge max. 6 mm. For general stitching operations - special version for DA-USA. Max. stitch length 6 mm.			0467 200260			2,8 x 3,7	0467 210130; 1,4					0367 221453; 0,8		0367 221443; 1,2				134-35 / 160
E21/5	-FA-273; -FAS-473-RAP-HP; -273 Allgemeine Näharbeiten in mittelschwerem Nähgut. Nadelabstand 5 mm. Stichlänge max. 6 mm. General stitching operation in medium weight material. Needle distance 5 mm. Max. stitch length 6 mm.			0467 202240 0367 142070 0367 142080			2,2 x 3,2	0467 212210; 1,4					0367 222243; 0,8			0067 222333	5	0367 232124	134-35 / 120
E21/6	-FA-273; -FAS-473-RAP-HP; -273 Wie E21/5, jedoch <u>Nadelabstand 6 mm</u> . As E21/5, but <u>needle distance 6 mm</u> .			0467 202040 0367 142070 0367 142080			2,2 x 3,2	0467 212060; 1,4					0367 222093; 0,8			0067 222343	6	0367 232094	134-35 / 120



E-Nr. E-No.	Für Unterklasse / For Subclass	Stichplatte Throat plate			Transporteur ④ Feed dog				Presserfuß ⑤ Presser foot			Transp. Fuß ⑥ Feeding foot						
		① Stichplatte / Throat plate	② Schieber, links / Slide, left	③ Schieber, rechts / Slide, right	Stichlochgröße / Stich hole size mm	Sägeverzahn / Serrated mm	Säge-schrägverzahn / Serrated, oblique mm	Kreuzverzahn / Cross toothed mm	Dachverzahn / Roof-shaped mm	Drückerfuß / Presser foot	Sägeverzahn / Serrated mm	Unverzahn / Non toothed	Hüpfersfuß, kreuzverz. / Skipping f., cross toothed	Sägeverzahn / serrated mm	Hüpfersfuß / Skipping foot	Unverzahn / Non toothed	Nadelabstand / Needle distance	Nadelhalter / Needle holder
E21/8	-FA-273; -FAS-473-RAP-HP; -273 Wie E21/5, jedoch <u>Nadelabstand 8 mm.</u> As E21/5, but <u>needle distance 8 mm.</u>	0467 202090	0367 142010	0367 142020	2,2 x 3,2	0467 212080; 1,4						0367 222103; 0,8			0067 222353	8	0367 232044	134-35 / 120
E21/10	-FA-273; -FAS-473-RAP-HP; -273 Wie E21/5, jedoch <u>Nadelabstand 10 mm.</u> As E21/5, but <u>needle distance 10 mm.</u>	0467 202160	0367 142010	0367 142020	2,2 x 3,2	0467 212140; 1,4						0367 222013; 0,8			0067 222383	10	0367 232024	134-35 / 120
E21/12	-FA-273; -FAS-473-RAP-HP; -273 Wie E21/5, jedoch <u>Nadelabstand 12 mm.</u> As E21/5, but <u>needle distance 12 mm.</u>	0467 202060	0367 142050	0367 142060	2,2 x 3,2	0467 212070; 1,4						0367 222313; 0,8			0067 222393	12	0367 232054	134-35 / 120
E21/14	-FA-273; -FAS-473-RAP-HP; -273 Wie E21/5, jedoch <u>Nadelabstand 14 mm.</u> As E21/5, but <u>needle distance 14 mm.</u>	0367 202280	0367 142050	0367 142060	2,2 x 3,2	0367 212240; 1,4						0367 222323; 0,8			0067 222413	14	0367 232154	134-35 / 120
E21/16	-FA-273; -FAS-473-RAP-HP; -273 Wie E21/5, jedoch <u>Nadelabstand 16 mm.</u> As E21/5, but <u>needle distance 16 mm.</u>	0467 202100	0367 142210	0367 142220	2,2 x 3,2	0467 212090; 1,4						0367 222333; 0,8			0067 222423	16	0367 232164	134-35 / 120
E21/18	-FA-273; -FAS-473-RAP-HP; -273 Wie E21/5, jedoch <u>Nadelabstand 18 mm.</u> As E21/5, but <u>needle distance 18 mm.</u>	0467 202190	0367 142210	0367 142220	2,2 x 3,2	0467 212170; 1,4						0367 222533; 0,8			0067 222433	18	0367 232204	134-35 / 120
E21/20	-FA-273; -FAS-473-RAP-HP; -273 Wie E21/5, jedoch <u>Nadelabstand 20 mm.</u> As E21/5, but <u>needle distance 20 mm.</u>	0467 202150	0367 142190	0367 142200	2,2 x 3,2	0467 212130; 1,4						0367 222543; 0,8			0067 222443	20	0367 232184	134-35 / 120



E-Nr. E-No.	Für Unterklasse / For Subclass	Stichplatte Throat plate			Transporteur Feed dog				Presserfuß Presser foot		Transp. Fuß Feeding foot		⑧							
		①	②	③	Stichlochgröße / Stich hole size mm	Sägeverzahn / Serrated mm	Säge-schrägverzahn / Serrated, oblique mm	Unverzahn / Non toothed	Dachverzahn / Roof-shaped mm	Unverzahn / Non toothed	Sägeverzahn / Serrated mm	Hüpfers / Skipping f., serrated		Hüpfers, kreuzverz. / Skipping f., cross toothed	Sägeverzahn / Serrated mm	Ausgleichfuß / Compensating foot	Hüpfers / Skipping foot	Unverzahn / Non toothed	Nadelabstand / Needle distance	Nadelhalter / Needle holder
E21/22	-FA-273; -FAS-473-RAP-HP; -273 Wie E21/5, jedoch <u>Nadelabstand 22 mm.</u> As E21/5, but <u>needle distance 22 mm.</u>	0467 202180	0367 142190	0367 142200	2,2 x 3,2	0467 212400; 1,4					0367 222413; 0,8						0067 222773	22	0367 232144	134-35 / 120
E22/8	-FA-273; -FAS-473-RAP-HP Näheinrichtung mit Ausgleichsfuß für Ausstepparbeiten in mittelschwerem Nähgut, inkl. pneumat. Anschlußteile. Pneumatisch einschaltbare Nahtmittenföhrung im Dröckerfuß integriert. Nadelstärke Nm 120-160. Nahtabstand 8 mm, Stichlänge max. 6 mm. Sewing equipment with compensating foot for topstitching medium weight material, incl. pneumatic connector. Pneumatic seam center guide integrated in the presser foot. Needle size Nm 120-160. Seam distance 8 mm, Stich length max. 6 mm.	0467 202090	0367 142010	0367 142020	2,2 x 3,2	0467 212080; 1,4				0768 222674				0768 222274					0367 232044	134-35 / 130
E22/10	-FA-273; -FAS-473-RAP-HP Näheinrichtung mit Ausgleichsfuß für Ausstepparbeiten in mittelschwerem Nähgut, inkl. pneumat. Anschlußteile. Pneumatisch einschaltbare Nahtmittenföhrung im Dröckerfuß integriert. Nadelstärke Nm 120-160. Nahtabstand 10 mm, Stichlänge max. 6 mm. Sewing equipment with compensating foot for topstitching medium weight material, incl. pneumatic connector. Pneumatic seam center guide integrated in the presser foot. Needle size Nm 120-160. Seam distance 10 mm, Stich length max. 6 mm.	0467 202160	0367 142010	0367 142020	2,2 x 3,2	0467 212140; 1,4				0768 222684				0768 222284					0367 232024	134-35 / 130
E25	-FA-373-RAP-HP; -FAS-373-RAP-HP; -373 Allgemeine NÄharbeiten in mittelschwerem Nähgut. Besonders gute Klettereigenschaften über QuernÄhte und dergleichen. Stichlänge max. 9 mm. Ersetzt die Näheinrichtung E4. General stitching operations in medium weight material. Particularly good properties of climbing over cross seams and the like. Max. stitch length 9 mm. Replace the sewing equipment E4.	0467 200020			2,2 x 3,2	0467 210070; 1,4						0767 220013; 0,8					0467 220483			134-35 / 130



E-Nr. E-No.	Für Unterklasse / For Subclass	Stichplatte Throat plate			Transporteur ④ Feed dog		Presserfuß ⑤ Presser foot		Transp. Fuß ⑥ Feeding foot										
		① Stichplatte / Throat plate	② Schieber, links / Slide, left	③ Schieber, rechts / Slide, right	Stichlochgröße / Stitch hole size mm	Sägeverzahn / Serrated mm	Säge-schrägverzahn / Serrated, oblique mm	Unverzahn / Non toothed	Dachverzahn / Roof-shaped mm	Unverzahn / Non toothed	Hüpfert / Skipping foot	Unverzahn / Non toothed	Hüpfert, kreuzverz. / Skipping f., cross toothed	Sägeverzahn / serrated mm	Hüpfert / Skipping foot	Unverzahn / Non toothed	Nadelabstand / Needle distance	Nadelhalter / Needle holder	Nadelsystem / -dicke / Needle system / -size
E29	-LG-73 Einfassen von mittelschwerem Nähgut. Stichlänge max. 6 mm. Binding medium weight material. Max. stitch length 6 mm.	0367 200290			ø 2,1			0367 210200				0367 220103; 0,8				0067 220993			134-35 / 130
E31/3	-VF-373; -VF-573 Nähen und gleichzeitiges Beschneiden der Stoffkanten für mittelschweres Nähgut. Schneidabstand 3 mm. Stichlänge max. 6 mm. Sewing and trimming simultaneously material edges for medium weight material. Cutting margin 3 mm. Max. stitch length 6 mm.	0467 200534			1,8 x 2,7	0467 210200; 1,4				0467 220733; 1,2					0467 220723			134-35 / 130	
E31/5	-VF-373; -VF-573 Nähen und gleichzeitiges Beschneiden der Stoffkanten für mittelschweres Nähgut. Schneidabstand 5 mm. Stichlänge max. 6 mm. Sewing and trimming simultaneously material edges for medium weight material. Cutting margin 5 mm. Max. stitch length 6 mm.	0467 200230			2,2 x 3,2	0467 210110; 1,4				0467 220443; 1,2				0467 220433			134-35 / 120		
E31/8	-VF-373; -VF-573 Wie E31/5, jedoch Schneidabstand 8 mm. As E31/5, but cutting margin 8 mm.	0467 200240			2,2 x 3,2	0467 210120; 1,4				0467 220463; 1,2				0467 220453			134-35 / 120		
E46	-FA-373-RAP-HP; -FAS-373-RAP-HP; -373 Kedararbeiten, <u>Kedernut 5 mm</u> breit. Stichlänge max. 6 mm. Piping operations, <u>piping groove 5 mm</u> wide. Max. stitch length 6 mm.	0367 200340			ø 2,5	0367 210230; 1,4			0367 220653					0067 220924			134-35 / 120		
E64	-FA-373-RAP-HP; -FAS-373-RAP-HP; -373 Kordelarbeiten, Kordelnut 6 mm breit. Stichlänge max. 6 mm. Cording operations, cording groove 6 mm wide. Max. stitch length 6 mm.	0467 200090			2,2 x 3,2	0467 210070; 1,4				0367 220363				0067 220863			134-35 / 120		



E-Nr. E-No.	Für Unterklasse / For Subclass	Stichplatte Throat plate			Transporteur Feed dog				Presserfuß Presser foot		Transp. Fuß Feeding foot								
		①	②	③	④	⑤	⑥	⑦	⑧	⑨	⑩								
Abb.-Nr. Fig.No.	Verwendungszweck / Use	Stichplatte / Throat plate	Schieber, links / Slide, left	Schieber, rechts / Slide, right	Stichlochgröße / Stich hole size	Sägeverzahn / Serrated	Säge-schrägverzahn / Serrated, oblique	Kreuzverzahn / Cross toothed	Unverzahn / Non toothed	Sägeverzahn / Serrated	Unverzahn / Non toothed	Hüpfersfuß, kreuzverz. / Skipping f., cross toothed	Sägeverzahn / Serrated	Ausgleichfuß / Compensating foot	Abdeckplatte / Cover plate	Unverzahn / Non toothed	Nadelabstand / Needle distance	Nadelhalter / Needle holder	Nadelsystem / -dicke / Needle system / -size
E65	-FA-373-RAP-HP; -FAS-373-RAP-HP; -373 Wie E64, jedoch <u>Kordelnut 8 mm</u> breit. As E64, but <u>cording groove 8 mm</u> wide.	0467 200090			2,2 x 3,2	0467 210070; 1,4					0367 220373					0367 220383			134-35 / 120
E66/10	-FA-273; -FAS-473-RAP-HP; -273 Reißverschlußarbeiten nach N281 in mittelschwerem Nähgut. Stichlänge max. 6 mm. Zipper operations according to N281 in medium weight material. Max stitch length 6 mm.	0367 202040	0367 142010	0367 142020	ø 1,7	0367 212040; 1,4					0367 222510; 0,8					0067 224100	10	0367 232024	134-35 / 120
E66/12	-FA-273; -FAS-473-RAP-HP; -273 Wie 66/10, jedoch Nadelabstand 12 mm. As 66/10, but needle distance 12 mm.	0467 202300	0367 142050	0367 142060	ø 2,0	0367 212260; 1,4					0367 222373; 0,8					0067 223220	12	0367 232054	134-35 / 120
E69	-LG-73 Einfassen von mittelschwerem Nähgut Stichlänge max. 9 mm. Binding medium weight material Max stitch length 9 mm.	0367 200300			ø 2,1				0367 210200			0367 220103; 0,8				0067 220993			134-35 / 130
E74/8	-FA-273; -FAS-473-RAP-HP; -273 Für Nährarbeiten in mittelschwerem unterschiedlich dickem Nähgut, mit Ausgleichfuß. Stichlänge max. 6 mm. For sewing operations in medium weight material of various thickness, with compensating foot. Max. stitch length 6 mm.	0467 202090	0367 142010	0367 142020	2,2 x 3,2	0467 212080; 1,4						0768 222133; 0,8		0768 222274			8	0367 232044	134-35 / 120
E74/10	-FA-273; -FAS-473-RAP-HP; -273 Wie E74/8, jedoch Nadelabstand 10 mm. As E74/8, but needle distance 10 mm.	0467 202090	0367 142010	0367 142020	2,2 x 3,2	0467 212140; 1,4						0767 222143; 0,8		0767 222084			10	0367 232024	134-35 / 120



E-Nr. E-No.	Für Unterklasse / For Subclass	Stichplatte Throat plate			Transporteur ④ Feed dog			Presserfuß ⑤ Presser foot			Transp. Fuß ⑥ Feeding foot									
		① Stichplatte / Throat plate	② Schieber, links / Slide, left	③ Schieber, rechts / Slide, right	Stichlochgröße / Stitch hole size mm	Sägeverzahnung / Serrated mm	Säge-schrägverzahnung / Serrated, oblique mm	Kreuzverzahnung / Cross toothed mm	Dachverzahnung / Roof-shaped mm	Unverzahnung / Non toothed	Sägeverzahnung / Serrated mm	Unverzahnung / Non toothed	Hüpfertfuß, kreuzverz. / Skipping f., cross toothed	Kreuzverzahnung / Cross toothed mm	Sägeverzahnung / Serrated mm	Hüpfertfuß / Skipping foot	Unverzahnung / Non toothed	Abdeckplatte / Cover plate	Nadelhalter / Needle holder	Nadelsystem / -dicke / Needle system / -size
E80	-AE-73; -AE-573 Nähen, gleichzeitiges Beschneiden und Einfassen der Stoffkante von mittelschwerem Nähgut. Schneidabstand 11,5 mm. Stichlänge max. 6 mm. Sewing and simultaneous edge trimming and binding of medium weight material. Cutting margin 11,5 mm. Max. stitch length 6 mm.	0367 200330			ø 2,0	0367 210213; 1,4						0767 220143; 1,2					0767 220133	0367 330790		134-35 / 120
E81	-AE-73; -AE-573 Wie E80, jedoch Schneidabstand 13,5 mm. As E80, but cutting margin 13,5 mm.	0367 200330			ø 2,0	0367 900071; 1,4						0767 220143; 1,2				0767 220113	0367 330790		134-35 / 120	
E82	-AE-73; -AE-573 Wie E80, jedoch Schneidabstand 8,7 mm. As E80, but cutting margin 8,7 mm.	0367 200330			ø 2,0	0367 900120; 1,4						0767 220143; 1,2	0767 220123; 1,2				0367 331730		134-35 / 120	
E101	-KFA-373-RAP-HP Allgemeine Näharbeiten in mittelschwerem Nähgut. Nadeldicke Nm 110-140. Stichlänge max. 6 mm. General stitching operation in medium weight material. Needle size Nm 110-140. Max stitch length 6 mm.	0767 200050			2,2 x 3,2	0767 210030; 1,4					0367 220993			0467 220013					134-35 / 120	
E102	-KFA-373-RAP-HP Allgemeine Näharbeiten in mittelschwerem Nähgut. Nadeldicke Nm 110-140. Stichlänge max. 9 mm. General stitching operation in medium weight material. Needle size Nm 110-140. Max stitch length 9 mm.	0767 200030			2,2 x 3,2	0767 210030; 1,4					0467 220043			0467 220013					134-35 / 120	



E-Nr. E-No.	Für Unterklasse / For Subclass	Stichplatte Throat plate			Transporteur Feed dog				Presserfuß Presser foot			Transp. Fuß Feeding foot							
		① Stichplatte / Throat plate	② Schieber, links / Slide, left	③ Schieber, rechts / Slide, right	Stichlochgröße / Stitch hole size mm	Sägeverzahnung / Serrated mm	Säge-schrägverzahnung / Serrated, oblique mm	Kreuzverzahnung / Cross toothed mm	Dachverzahnung / Roof-shaped mm	Unverzahnung / Non toothed	Sägeverzahnung / Serrated mm	Unverzahnung / Non toothed	Hüpfersfuß, kreuzverz. / Skipping f., cross toothed	Sägeverzahnung / Serrated mm	Hüpfersfuß / Skipping foot	Unverzahnung / Non toothed	Nadelabstand / Needle distance	Nadelhalter / Needle holder	⑧ Nadelsystem / -dicke / Needle system / -size
Abb.-Nr. Fig.No.	Verwendungszweck / Use																		
E103	-KFA-573-RAP-HP Allgemeine Näharbeiten in mittelschwerem Nähgut. Nadeldicke Nm 110-140. Stichlänge max. 6 mm. General stitching operation in medium weight material. Needle size Nm 110-140. Max stitch length 6 mm.	0767 200080			2,2 x 3,2	0767 210030; 1,4				0367 220993			0467 220013						134-35 / 120
E104	-KFA-573-RAP-HP Allgemeine Näharbeiten in mittelschwerem Nähgut. Nadeldicke Nm 110-140. Stichlänge max. 9 mm. General stitching operation in medium weight material. Needle size Nm 110-140. Max stitch length 9 mm.	0767 200070			2,2 x 3,2	0767 210030; 1,4				0467 220043			0467 220013						134-35 / 120
E201	-FAS-573-RAP-HP Allgemeine Näharbeiten in mittelschwerem Nähgut. Stichlänge max. 6 mm. General stitching operation in medium weight material. Max stitch length 6 mm.	0467 200090			2,2 x 3,2	0467 210060; 1,4						0367 220993; 0,8					0467 220013		134-35 / 120
E202	-FAS-573-RAP-HP Allgemeine Näharbeiten in mittelschwerem Nähgut. Stichlänge max. 9 mm. General stitching operation in medium weight material. Max stitch length 9 mm.	0467 200020			2,2 x 3,2	0467 210060; 1,4						0467 220043; 0,8					0467 220013		134-35 / 120
E205	-FAS-573-RAP-HP Kantensteppen ab 1 mm für mittelschweres Nähgut. Stichlänge max. 6 mm. Topstitching margin 1 mm and more for medium weight material. Max stitch length 6 mm.	0467 200090			2,2 x 3,2	0467 210060; 1,4						0367 220283; 0,8					0067 220713		134-35 / 120



E-Nr. E-No.	Für Unterklasse / For Subclass	Stichplatte Throat plate			Transporteur ④ Feed dog				Presserfuß ⑤ Presser foot			Transp. Fuß ⑥ Feeding foot							
		① Stichplatte / Throat plate	② Schieber, links / Slide, left	③ Schieber, rechts / Slide, right	Stichlochgröße / Stitch hole size mm	Sägezahn / Serrated mm	Säge-schrägverzahn / Serrated, oblique mm	Kreuzverzahn / Cross toothed mm	Dachverzahn / Roof-shaped mm	Unverzahn / Non toothed	Sägeverzahn / Serrated mm	Unverzahn / Non toothed	Hüpfertfuß, kreuzverz. / Skipping f., cross toothed	Sägeverzahn / Serrated mm	Hüpfertfuß / Skipping foot	Unverzahn / Non toothed	Nadelabstand / Needle distance	Nadelhalter / Needle holder	⑧ Nadelsystem / -dicke / Needle system / -size
E207	-FAS-573-RAP-HP Allgemeine Näharbeiten in mittelschwerem Nähgut. Stichlänge max. 6 mm. General stitching operation in medium weight material. Max stitch length 6 mm.	0467 200090			2,2 x 3,2	0467 210060; 1,4						0367 221543; 0,8			0367 221553				134-35 / 120
E215	-FAS-573-RAP-HP Kedararbeiten, <u>Kedernut 4 mm</u> breit, links der Nadel. Stichlänge max. 6 mm. Piping operations, <u>piping groove 4 mm</u> wide, to the left of the needle. Max stitch length 6 mm.	0467 200090			2,2 x 3,2	0467 210060; 1,4						0367 220773; 0,8			0167 220583				134-35 / 120
E216	-FAS-573-RAP-HP Kedararbeiten, <u>Kedernut 5 mm</u> breit, links der Nadel. Stichlänge max. 6 mm. Piping operations, <u>piping groove 5 mm</u> wide, to the left of the needle. Max stitch length 6 mm.	0467 200090			2,2 x 3,2	0467 210060; 1,4						0367 220783; 0,8			0167 220603				134-35 / 120
E217	-FAS-573-RAP-HP Kedararbeiten, <u>Kedernut 6 mm</u> breit, links der Nadel. Stichlänge max. 6 mm. Piping operations, <u>piping groove 6 mm</u> wide, to the left of the needle. Max stitch length 6 mm.	0467 200090			2,2 x 3,2	0467 210060; 1,4						0367 220793; 0,8			0167 220363				134-35 / 120
E218	-FAS-573-RAP-HP Kedararbeiten, <u>Kedernut 7 mm</u> breit, links der Nadel. Stichlänge max. 6 mm. Piping operations, <u>piping groove 7 mm</u> wide, to the left of the needle. Max stitch length 6 mm.	0467 200090			2,2 x 3,2	0467 210060; 1,4						0367 220803; 0,8			0167 220633				134-35 / 120



E-Nr. E-No.	Für Unterklasse / For Subclass	Abb.-Nr. Fig.No.	Verwendungszweck / Use	Stichplatte Throat plate			Transporteur Feed dog				Presserfuß Presser foot		Transp. Fuß Feeding foot						
				① Stichplatte / Throat plate	② Schieber, links / Slide, left	③ Schieber, rechts / Slide, right	Stichlochgröße / Stitch hole size mm	Sägeverzahn / Serrated mm	Säge-schrägverzahn / Serrated, oblique mm	Kreuzverzahn / Cross toothed mm	Dachverzahn / Roof-shaped mm	Unverzahn / Non toothed	Sägeverzahn / Serrated mm	Unverzahn / Non toothed	Hüpfersfuß, kreuzverz. / Skipping f., cross toothed	Sägeverzahn / Serrated mm	Hüpfersfuß / Skipping foot	Unverzahn / Non toothed	Nadelabstand / Needle distance
E219	-FAS-573-RAP-HP		Kedararbeiten, <u>Kedernut 8 mm</u> breit, links der Nadel. Stichlänge max. 6 mm. Piping operations, <u>piping groove 8 mm</u> wide, to the left of the needle. Max stitch length 6 mm.	0467 200090			2,2 x 3,2	0467 210060; 1,4					0367 220813; 0,8			0167 220653			134-35 / 120
E220	-FAS-573-RAP-HP		Für allgemeine Nährarbeiten - spezielle Ausführung für DA-USA . Stichlänge max. 6 mm. For general stitching operations - special version for DA-USA. Max stitch length 6 mm.	0467 200260			2,2 x 3,2	0467 210010; 1,4					0367 221453; 0,8	0367 221443; 1,2					134-35 / 160
E225	-FAS-573-RAP-HP		Allgemeine Nährarbeiten in mittelschwerem Nähgut. Besonders gute Klettereigenschaften über Quernähte und dergleichen. Stichlänge max. 9 mm. Ersetzt die Näheinrichtung E4. General stitching operations in medium weight material. Particularly good properties of climbing over cross seams and the like. Max stitch length 9 mm. Replaces the sewing equipment E4.	0467 200020			2,2 x 3,2	0467 210060; 1,4					0767 220013; 0,8			0467 220483			134-35 / 130
E264	-FAS-573-RAP-HP		Kordelarbeiten, <u>Kordelnut 6 mm</u> breit. Stichlänge max. 6 mm. Cording operations, <u>cording groove 6 mm</u> wide. Max stitch length 6 mm.	0467 200090			2,2 x 3,2	0467 210060; 1,4				0367 220363				0067 220863			134-35 / 120
E265	-FAS-573-RAP-HP		Wie E264, jedoch <u>Kordelnut 8 mm</u> breit. As E264, but <u>cording groove 8 mm</u> wide.	0467 200090			2,2 x 3,2	0467 210060; 1,4				0367 220373				0367 220383			134-35 / 120

Für diese technische Unterlagen behalten wir den Urheberrecht gemäß DIN 34, Absatz 2.1 vor.

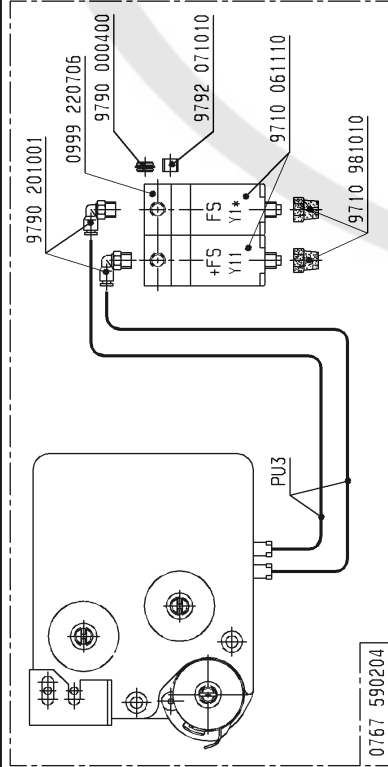

0767 590204
auf Wunsch
on request

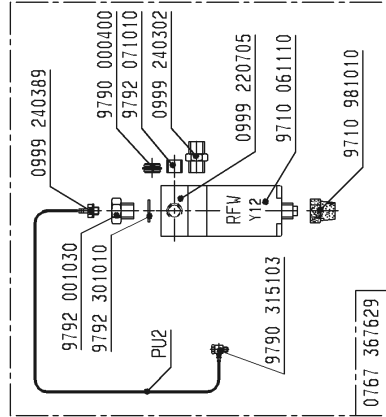

0767 367629
auf Wunsch
on request

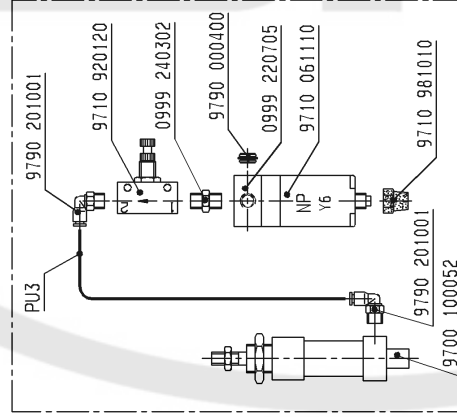

0467 367799
auf Wunsch
on request

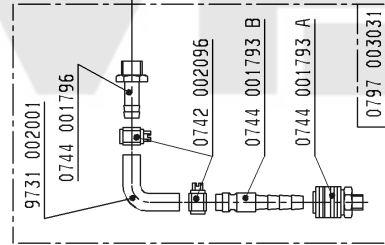

0797 003031
auf Wunsch
on request

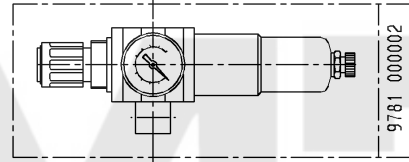

9781 000002
auf Wunsch
on request

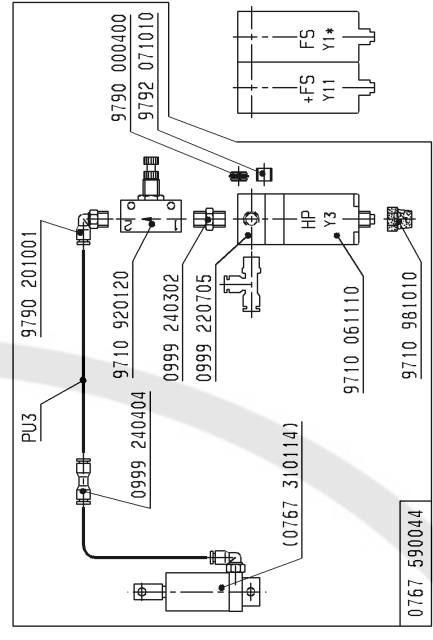
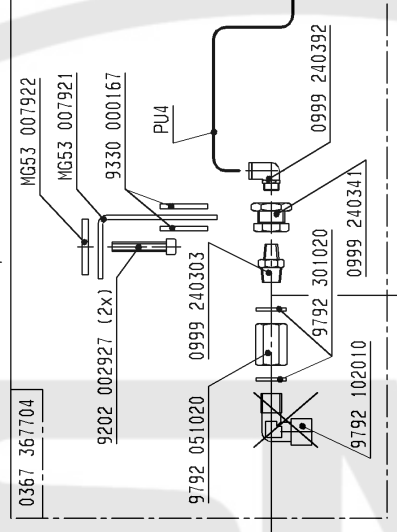

0467 367959
auf Wunsch
on request

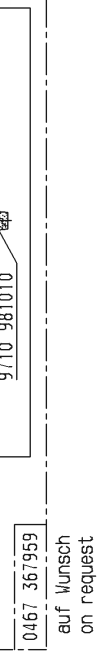

Schlauch
Hose
PU2
PU3
PU4
Teile-Nr. (Meterware)
Part-No. (Yarded goods)
0699 979265
9731 005004
9731 006004

Tag	30.01.03	gez.	Schmid	gepr.	Scholz	gez.	Key

Preu. - Geräteplan
für 0767-FAS-373-RAP-HP
Preu. - Elements-Plan
for 0767-FAS-373-RAP-HP

1) Ersatzventil ohne Montageplatte 9710 061110
Replacement valve without mounting plate 9710 061110

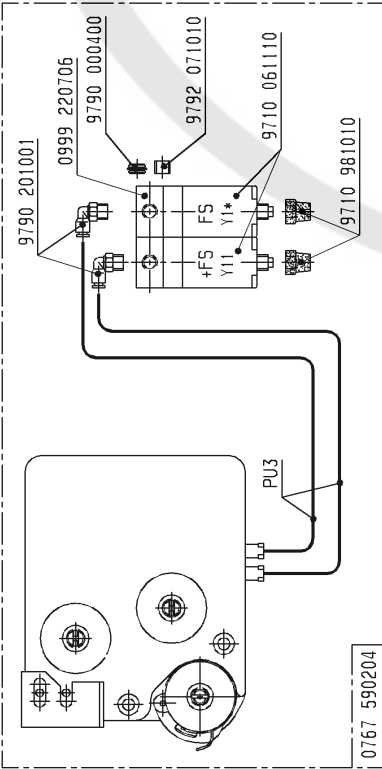

0767 590204
auf Wunsch
on request

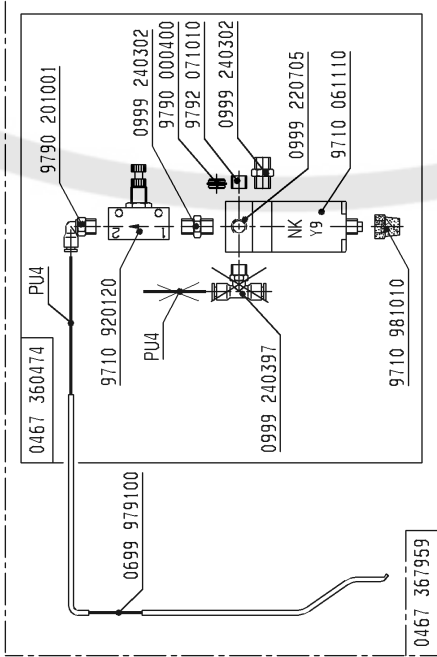

0467 367959
auf Wunsch
on request

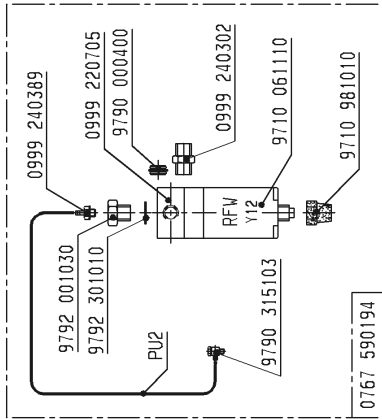

0767 590194
auf Wunsch
on request

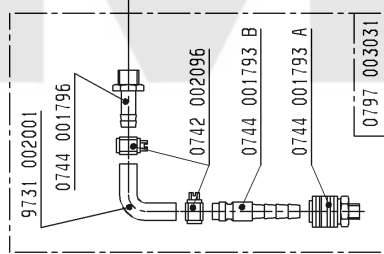
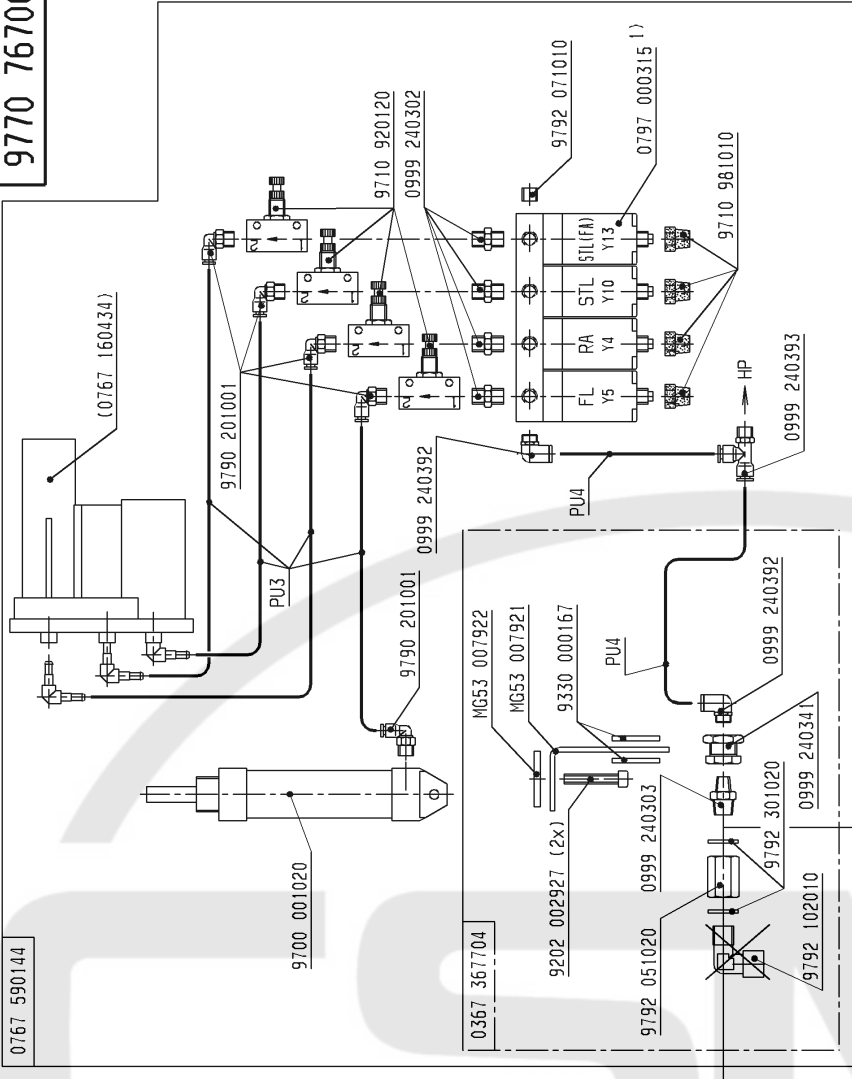

0797 003031
auf Wunsch
on request

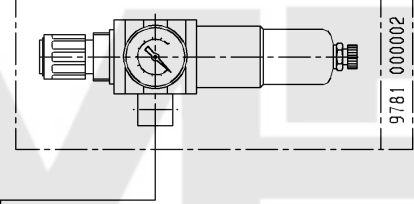

9781 000002
auf Wunsch
on request

Tag	30.01.03	gez.	Schmid	gepr.	Scholz	gez.	Key
Pneu.- Geräteplan für 0767-KFA-373-RAP-HP							
Pneu.- Elements-Plan for 0767-KFA-373-RAP-HP							
01.0	18.05.04		Schmid				
And.	Tag	gez.	gepr.				

Schlauch	Teile-Nr. (Meterware)
Hose	Part-No. (Yarded goods)
PU2	0699 979265
PU3	9731 005004
PU4	9731 006004

1) Ersatzventil ohne Montageplatte 9710 061110
Replacement valve without mounting plate 9710 061110

Für diese technische
Unterlage behalten wir
den Urnehmerschutz gemäß
DIN 34, Absatz 2.1 vor.

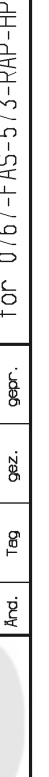
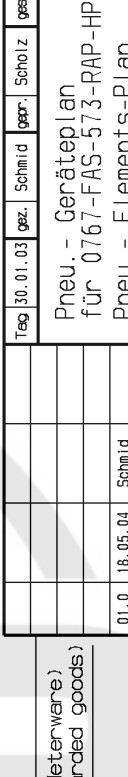
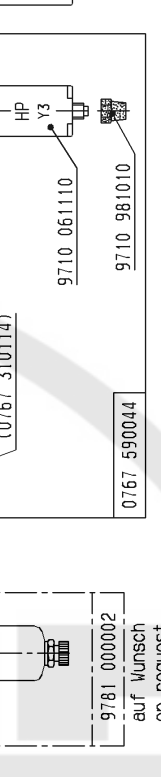
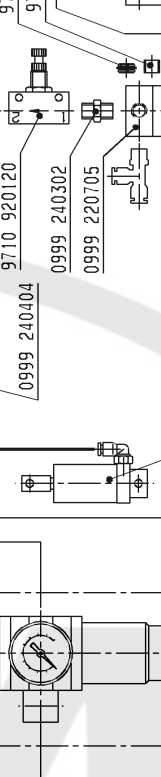
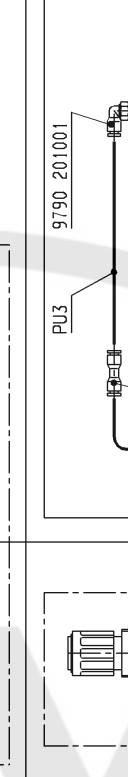
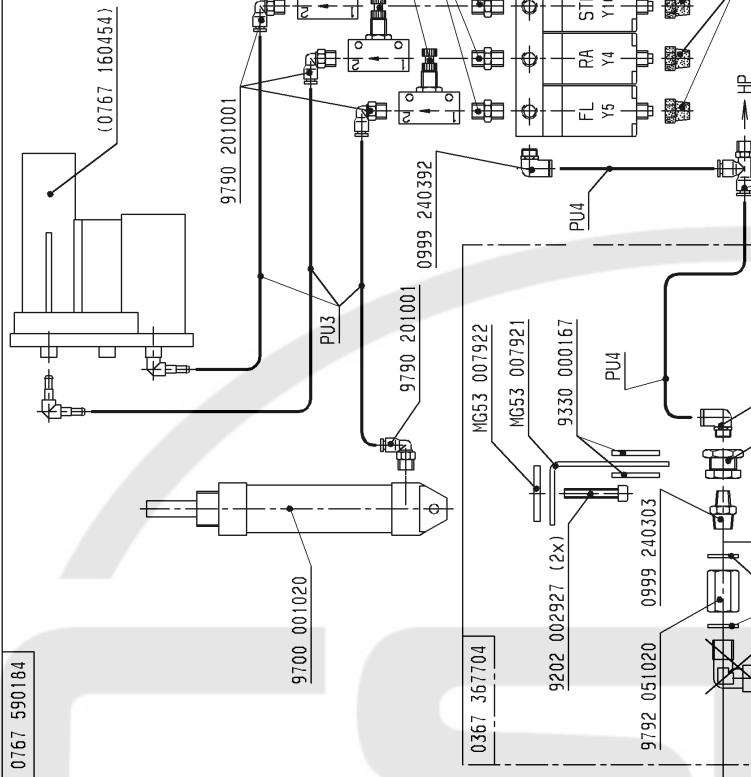

Für diese technische Unterlage behalten wir den Urheberrecht gemäß DIN 34, Absatz 2.1 vor.

Tag	30.01.03	gez.	Schmid	gepr.	Scholz	ges.
Pneu.- Geräteplan für 0767-FAS-573-RAP-HP						
Pneu.- Elements-Plan for 0767-FAS-573-RAP-HP						
And.	01.0	18.05.04	Schmid	gez.	gepr.	

Schlauch	Teile-Nr. (Meterware)		
Hose	Part-No. (Yarded goods)		
PU2	0699	979265	
PU3	9731	005004	
PU4	9731	006004	

1) Ersatzventil ohne Montageplatte 9710 061110
 Replacement valve without mounting plate 9710 061110

Tag	30.01.03	gez.	Schmid	gepr.	Scholz	ges.
Pneu.- Geräteplan für 0767-FAS-573-RAP-HP						
Pneu.- Elements-Plan for 0767-FAS-573-RAP-HP						
And.	01.0	18.05.04	Schmid	gez.	gepr.	

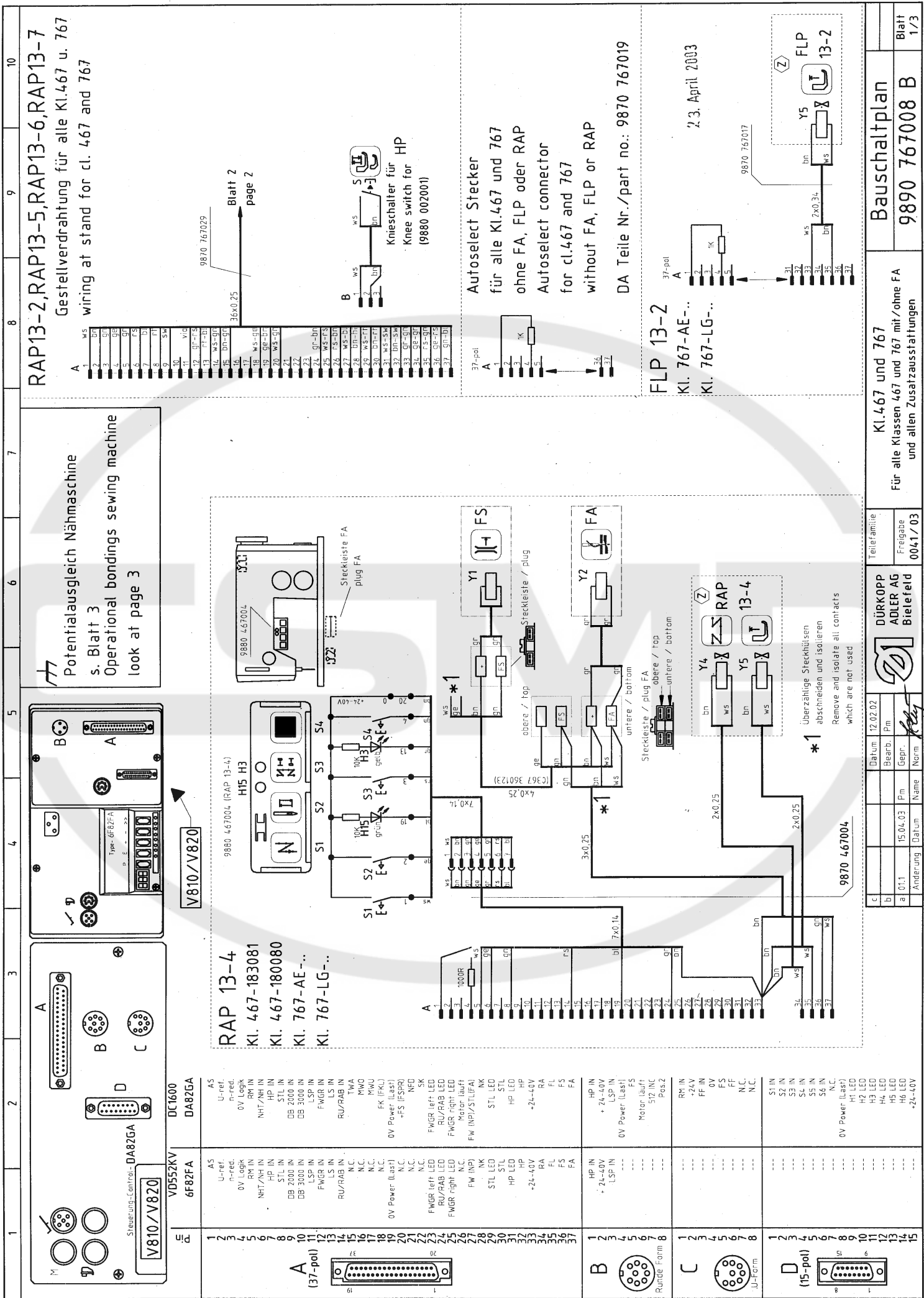

Potentialausgleich Nähmaschine
s. Blatt 3
Operational bondings sewing machine
look at page 3

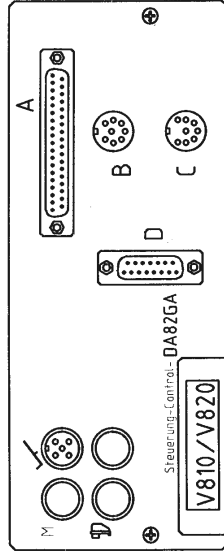
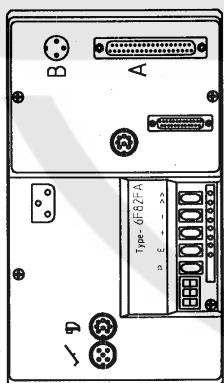

RAP 13-4
Kl. 467-183081
Kl. 467-180080
Kl. 767-AE-...
Kl. 767-LG-..

1	AS	U-ref.
2	n-red.	0V Logik
3	RM IN	NHT/AN IN
4	HP IN	STL IN
5	DB 2000 IN	DB 3000 IN
6	LSP IN	FWGR IN
7	LS IN	RU/RAB IN
8	N.C.	TWA
9	N.C.	MWO
10	N.C.	MWU
11	N.C.	FK (FKL)
12	N.C.	0V Power (Last)
13	N.C.	+FS (FSR)
14	N.C.	NED
15	N.C.	SK
16	N.C.	FWGR left LED
17	N.C.	RU/RAB LED
18	N.C.	FWGR right LED
19	N.C.	FW (NPI/STL/FA)
20	N.C.	STL LED
21	N.C.	HP LED
22	N.C.	HP LED
23	N.C.	+24-40V
24	N.C.	RA
25	N.C.	FL
26	N.C.	FS
27	N.C.	FA
28	HP IN	+24-40V
29	LSP IN	LSP IN
30	0V Power (Last)	0V Power (Last)
31	Motor (Last)	Motor (Last)
32	Motor (Last)	Motor (Last)
33	Motor (Last)	Motor (Last)
34	Motor (Last)	Motor (Last)
35	Motor (Last)	Motor (Last)
36	Motor (Last)	Motor (Last)
37	Motor (Last)	Motor (Last)

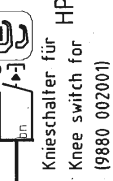

Autoselect Stecker
für alle Kl.467 und 767
ohne FA, FLP oder RAP
Autoselect connector
for cl.467 and 767
without FA, FLP or RAP
DA Teile Nr./part no.: 9870 767019

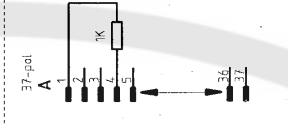

FLP 13-2
Kl. 767-AE-...
Kl. 767-LG-...

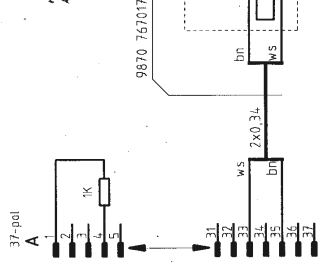

23. April 2003

c		Datum		12.02.02		Teilerfamilie		Bauschaltplan	
b		Bearb.		Pm		Freigabe		9890 767008 B	
a		15.04.03		Pm		0041 / 03		Für alle Klassen 467 und 767 mit/ohne FA und allen Zusatzausstattungen	
1		Änderung		Datum		Name		Blatt	
2								1/3	

1	WS	36x0.25	Blatt 2	9	10
2	GF		page 2		
3	GE				
4	GF				
5	GF				
6	FS				
7	BI				
8	FI				
9	SW				
10	VID				
11	QT-FS				
12	QT-FS				
13	FT-B				
14	WS-GT				
15	BN-GT				
16	WS				
17	WS-GE				
18	GE-BT				
19	GE-BT				
20	WS-GT				
21	WS				
22	WS				
23	GF				
24	WS-FS				
25	WS-BN				
26	DNH-FI				
27	WS-FI				
28	BN-FI				
29	WS-SW				
30	BN-SW				
31	GF-GT				
32	GF-GT				
33	FS-GT				
34	FS-GT				
35	FS-GT				
36	GF-BN				
37	GF-BN				

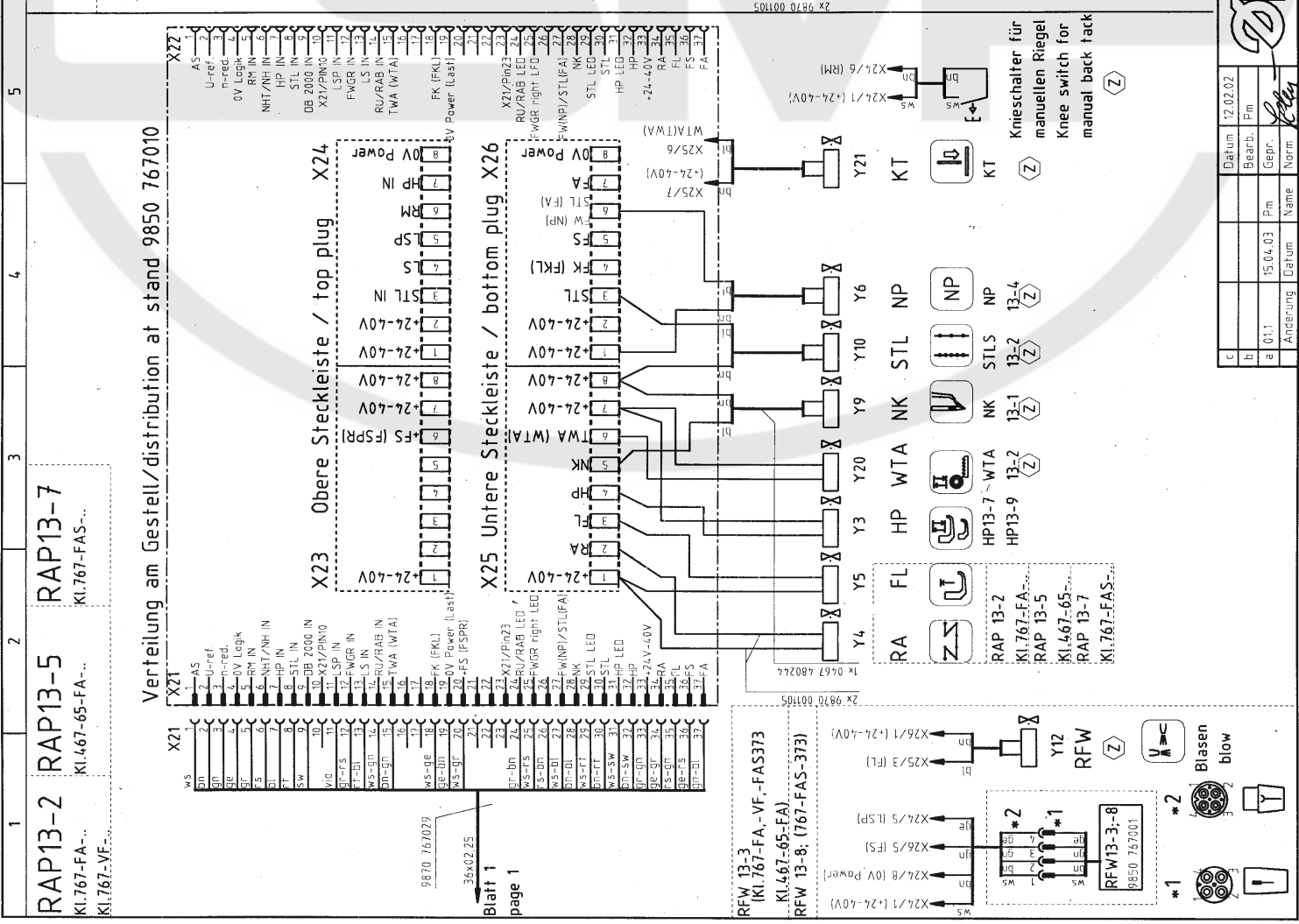
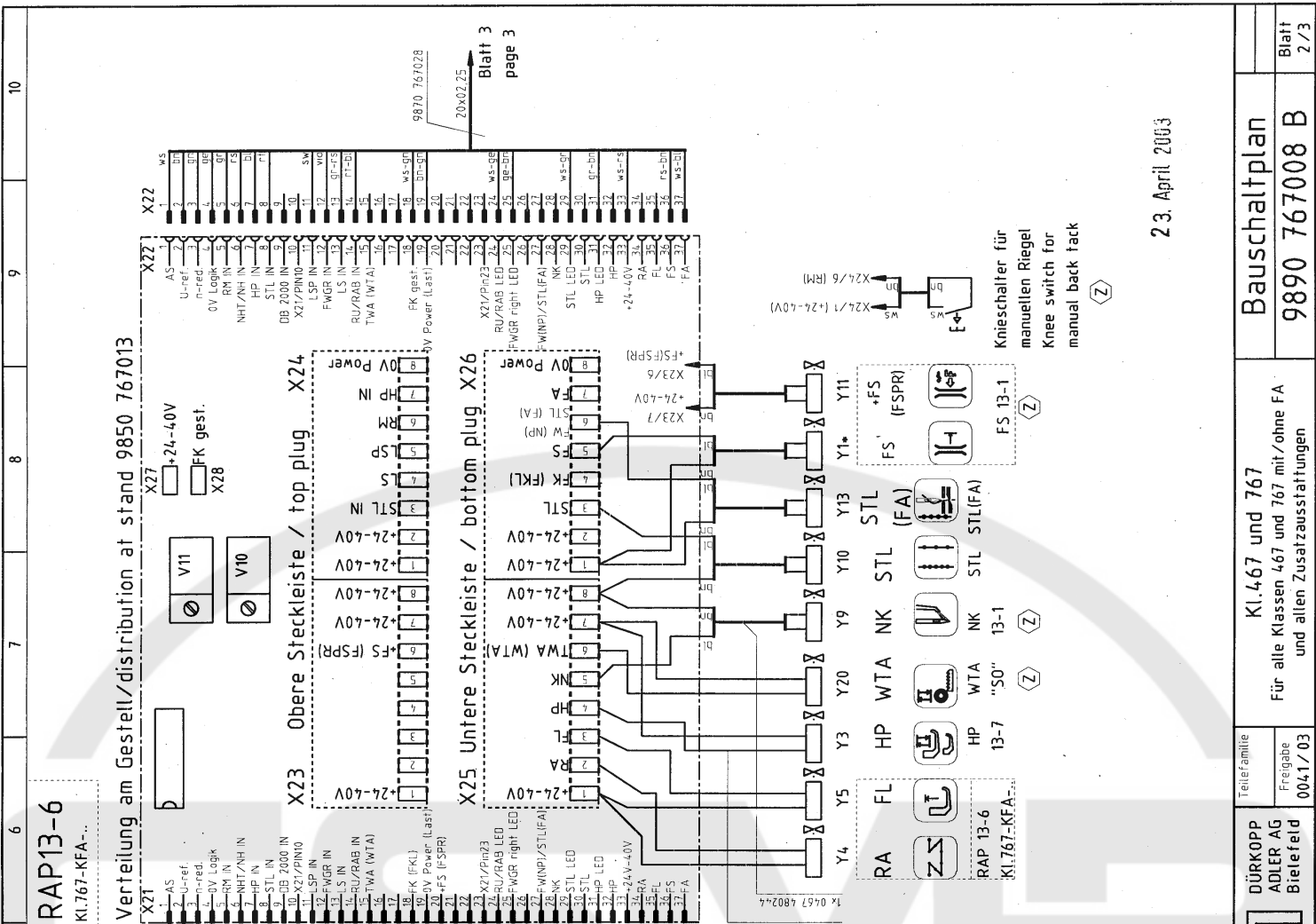

23. April 2003

Blatt
2 / 3

Bauschaltplan
9890 767008 B

Für alle Klassen 467 und 767 mit/ohne FA
und allen Zusatzausstattungen

Freigeabe
0041/03

DÜRKOPP
ADLER AG
Bielefeld

Datei: 12.02.02		
c	Änderung	Datum
b	Bearb.	Pm
a	011	15.04.03
		Gepr.
		Name
		Norm

Blasen
blow

*1

*2

Blatt 2/3

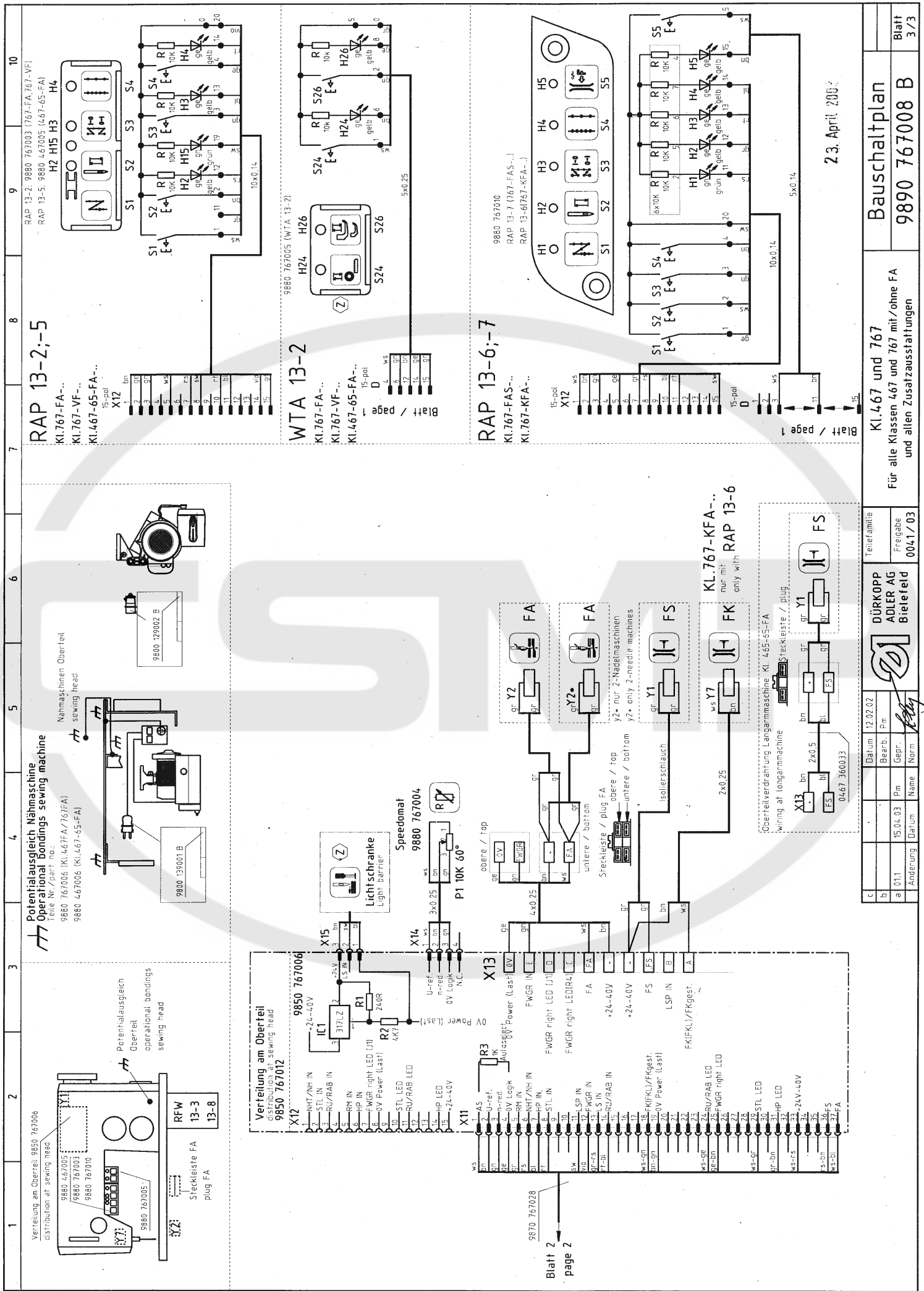

Potentialausgleich Nähmaschine
Operational bindings sewing machine

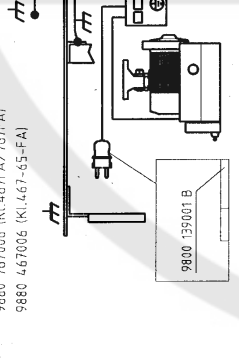

RAP 13-2;-5

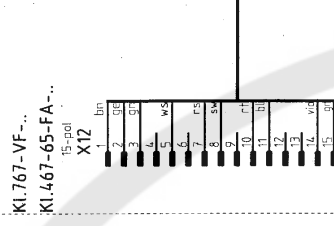

WTA 13-2

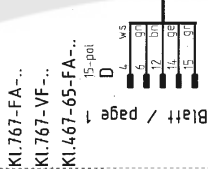

RAP 13-6;-7

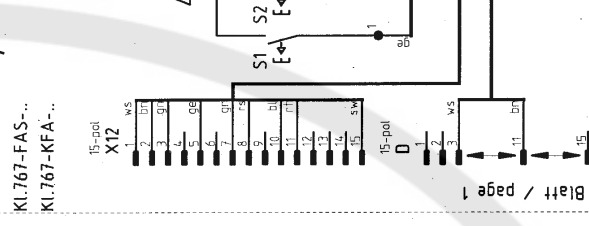

Verteilung am Oberteil
Distribution at sewing head

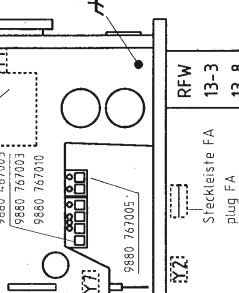

Verteilung am Oberteil
Distribution at sewing head

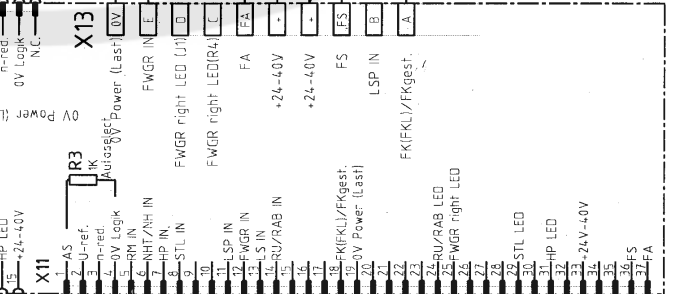
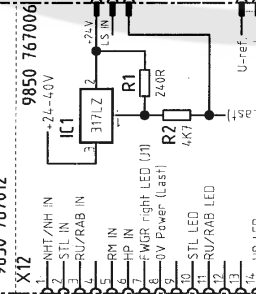

23. April 2009

c		Datum	12.02.02	Teilfamilie	
b		Bearb.	Pm	Freigabe	
a	011	15.04.03	Pm	Gepr.	
Änderung		Datum	Name	Norm	
DÜRKOPP ADLER AG Bielefeld					
Für alle Klassen 467 und 767 mit/ohne FA und allen Zusatzausstattungen					
Bauschaltplan				9890 767008 B	
Blatt 3/3					

