

T-8750C

パーツブック
PARTS BOOK

2本針本縫角縫大釜ミシン

TWIN NEEDLE SPLIT NEEDLE BAR LOCK STITCHER WITH LARGE HOOK

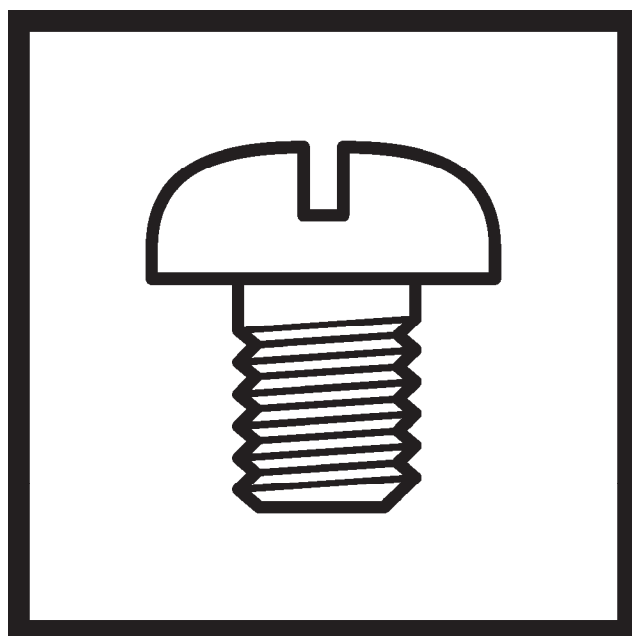

brother[®]

最新の部品情報は Parts Navigation でご覧いただけます。 <http://partsbook.brother.co.jp/partsnavi/jpn/>
The latest parts information, refer to the Parts Navigation. <http://partsbook.brother.co.jp/partsnavi/eng/>

型式板の見方



5: 厚物

Description of model plate



5: Heavy-weight materials

パーツブックご利用に際して

1. このリストは、2010年5月のデータに基づいて作成されたものです。
2. 部品は予告なしに設計変更される場合があります。
3. 組単位で補給する部品は、破線で示してあります。
4. イラスト中で数字(REF.NO)に“+”がついている部品は、仕様により異なります。
詳細は、リストを参照してください。

目 次

A. 主体関係	1
B. 上軸関係	3
C. 針棒揺動関係	5
D. 針棒切換操作関係	9
E. 押え関係	11
F. 送り関係	13
G. 送り軸関係	15
H. ゲージ関係	17
J1. かま関係	19
J2. かま関係	21
K. 下軸関係	23
L. 給油潤滑関係	25
M. 糸通し関係	29
N. 糸巻関係	31
Z1. 付属品関係	33
Z2. 付属品関係	35
Wa. 警告ラベル	37
Ga. ゲージ部品一覧表	38
索引	40

Notes for using this parts book

1. This list was prepared based on information available in May 2010.
2. Parts are subject to changes in design without prior notice.
3. Parts supplied as complete assemblies are circled by a dotted line.
4. The part which has the symbol "+" on its number (REF.NO) in the figure differs depending on the specification. For details, refer to the parts list.

CONTENTS

A. Machine body	1
B. Upper shaft mechanism	3
C. Needle bar rocking mechanism	5
D. Needle bar flip-up mechanism	9
E. Presser foot mechanism	11
F. Feed mechanism	13
G. Feed shaft mechanism	15
H. Gauge parts	17
J1. Rotary hook mechanism	19
J2. Rotary hook mechanism	21
K. Lower shaft mechanism	23
L. Lubrication	25
M. Threading mechanism	29
N. Bobbin winder mechanism	31
Z1. Accessories	33
Z2. Accessories	35
Wa. Warning labels	37
Ga. Gauge parts list	38
Index	40

A. 主体関係 / Machine body

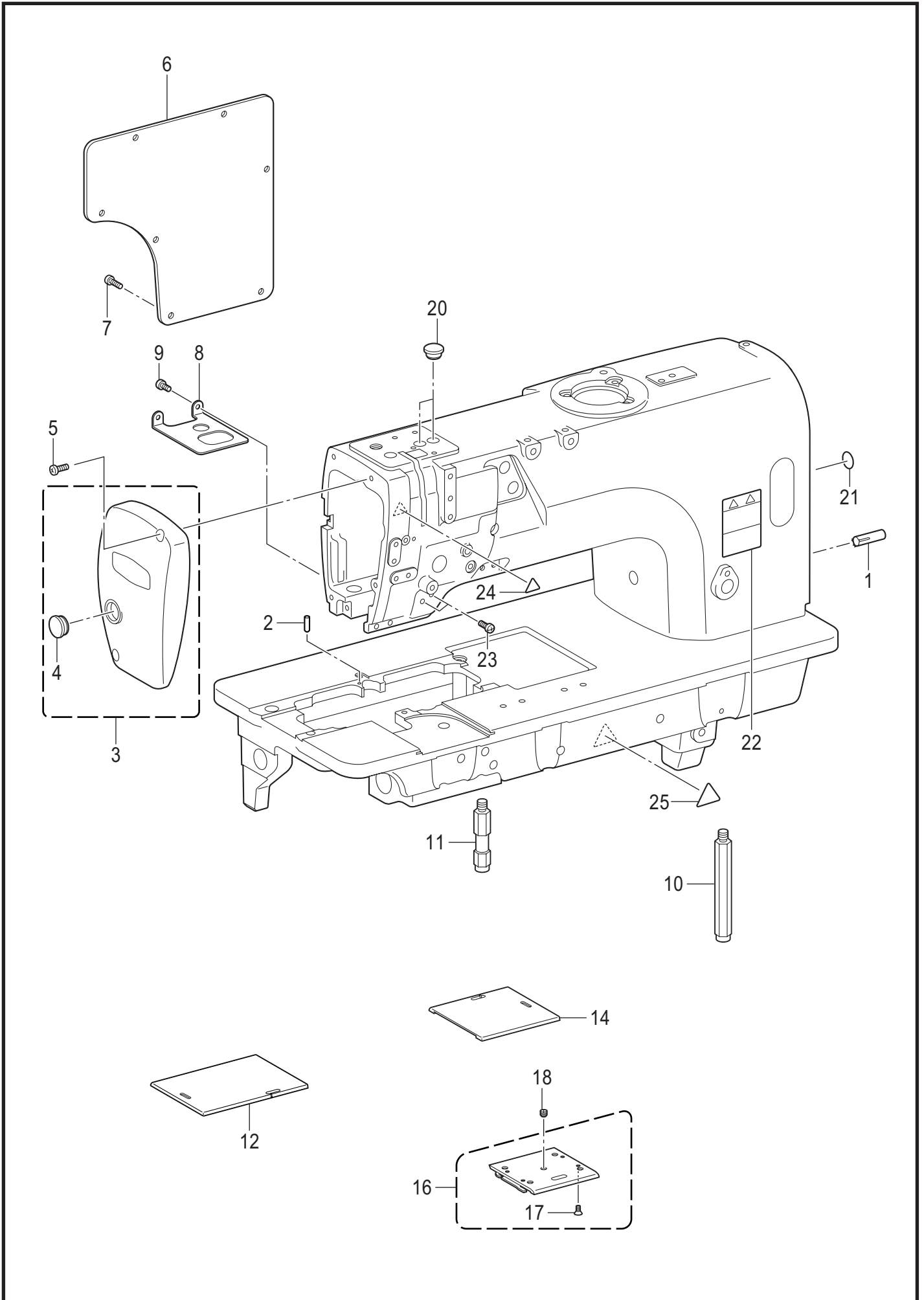

A. 主体関係 / Machine body

REF.NO	CODE	Q'TY	品名	NAME OF PARTS	RM
1	140063001	1	ミゾツキピン	DOWEL PIN	
2	SA3924001	1	ハリタイチキメピン	POSITIONING PIN	
3	SB1311001	1	メンイタクミ	FACE PLATE ASSY	
4	104449001	1	ゴムセン15.5	RUBBER CAP, 15.5	
5	062501416	2	ナベコ5X14	SCREW PAN M5X14	
6	SA2441101	1	ガワイタ	REAR COVER	
7	062501216	7	ナベコ5X12	SCREW PAN M5X12	
8	SA4370101	1	ダストプレート	DUST PROTECTOR	
9	062500616	2	ナベコ5X6	SCREW PAN M5X6	
10	SA2444101	1	キヤクチュウL	BED LEG L	
11	SA2445101	1	キヤクチュウS	BED LEG S	
12	SA2448101	1	スベリイタLA	SLIDE PLATE, LA	
14	SA2450101	1	スベリイタR	SLIDE PLATE, R	
16	S36663001	1	スベリイタFクミ	SLIDE PLATE F ASSY	
17	S34438001	4	サラネジ3.18X4	SCREW, FLAT SM3.18-40X4	
18	116010001	1	トメネジ5.16	SET SCREW, SM5.16-40X4	
20	SA2929001	2	ゴムセン12.5	RUBBER CAP, 12.5	
21	S37060001	1	ア-スマーク	LABEL, GROUNDING	
22	SA9826001	1	ソウサチュウイラベル	LABEL CAUTION	
23	062500816	2	ナベコ5X8	SCREW PAN M5X8	
24	SA9957001	1	ワーニングマーク	INJURY MARK	
25	SA9957002	1	ワーニングマーク	INJURY MARK	

B. 上軸関係 / Upper shaft mechanism

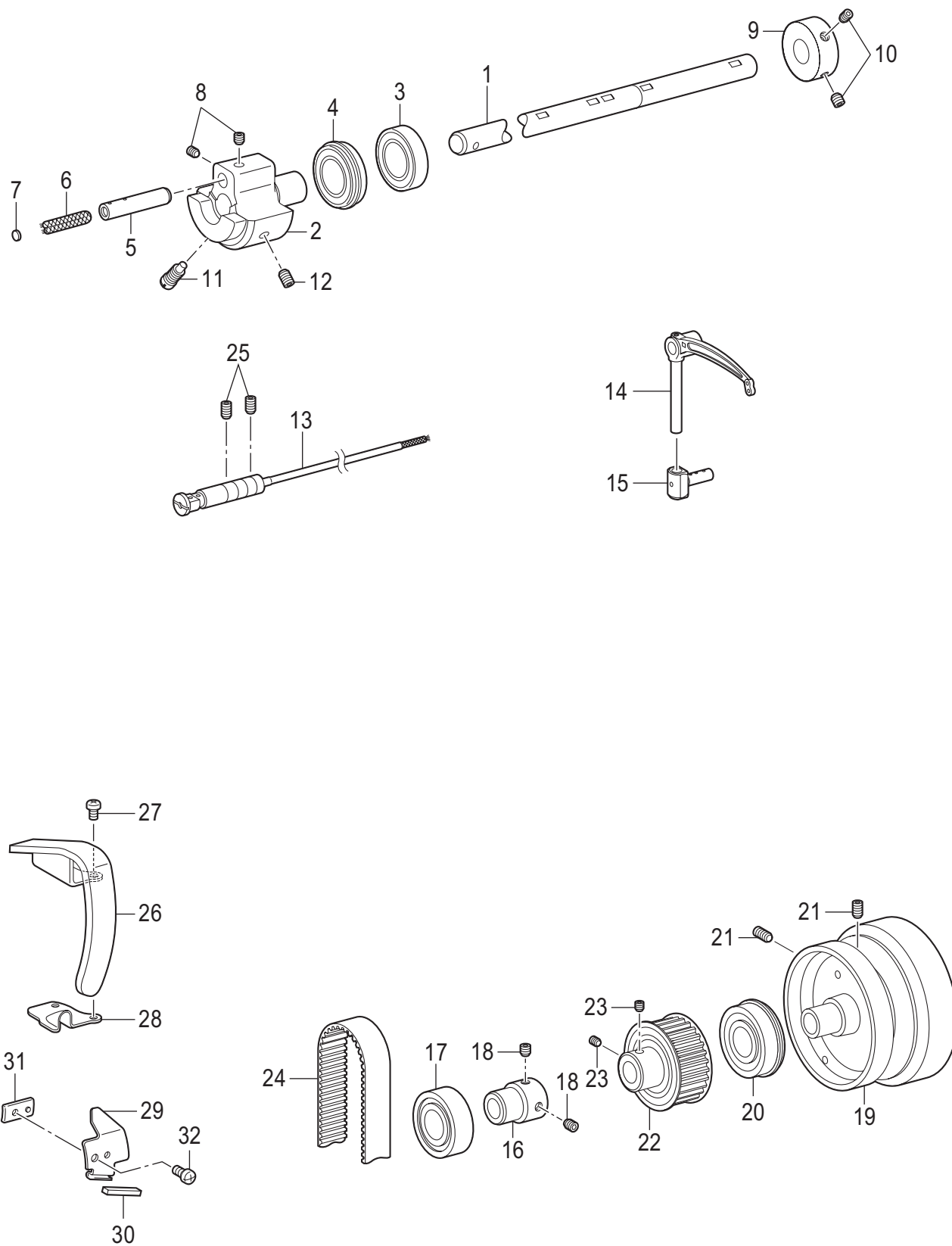

B. 上軸関係 / Upper shaft mechanism

REF.NO	CODE	Q'TY	品名	NAME OF PARTS	RM
1	SA4550001	1	ウワジクST	UPPER SHAFT, ST	
2	SA4373001	1	テンビンクランク	THREAD TAKE-UP CRANK	
3	SB1485001	1	タマジクウケ6004ZZ	BALL BEARING, 6004ZZ	
4	SB1484001	1	タマジクウケ6004ZZNR	BALL BEARING, 6004ZZNR	
5	SA6166001	1	ハリボウクランクジク	CRANKSHAFT	
6	117006001	1	クミヒモ	WICK, L=60	
7	113014000	1	クミヒモフタ	PUSHER	
8	S25260001	2	アナヒラ6X5ホソメ	SET SCREW SOCKET (FT) M6X5	
9	SA1120001	1	イトマキドウリン	BOBBIN WINDER DRIVING WHEEL	
10	S23651001	2	アナヒラ6X6ホソメ	SET SCREW SOCKET (FT) M6X6	
11	S25235001	1	シメネジ8	SCREW M8	
12	S25236001	1	アナヒラ6X10ホソメ	SET SCREW SOCKET (FT) M6X10	
13	SA2861201	1	テンビンササエジクソウクミ	THREAD TAKE-UP S-SHAFT UNIT	
14	SA4368001	1	テンビンL5-Lクミ	THREAD TAKE-UP LEVER ASSY,L5-L	
15	S13160001	1	テンビンスベリコ2クミ	T-TAKE-UP SLIDE BLOCK ASSY, 2	
16	SA2748001	1	タマジクウケブツシュ	BALL BEARING BUSH	
17	076023800	1	Rタマジクウケ60/22ZZ	BALL BEARING RADIAL 60/22ZZ	
18	S23651001	2	アナヒラ6X6ホソメ	SET SCREW SOCKET (FT) M6X6	
19	SA2750101	1	プーリ	PULLY	
20	SB1536001	1	タマジクウケ6204ZZNR	BALL BEARING, 6204ZZNR	
21	012061036	2	アナヒラ6X10	SET SCREW SOCKET (FT) M6X10	
22	SA2720101	1	タイミングプーリU STクミ	TIMING PULLEY ASSY,U ST	
23	SA4214001	2	アナトメネジ6X6ホソメ	SET SCREW, SOCKET (CP) M6X6	
24	SA2463001	1	タイミングベルト	TIMING BELT	
25	012061036	2	アナヒラ6X10	SET SCREW SOCKET (FT) M6X10	
26	SA2469101	1	テンビンカバー	THREAD TAKE-UP LEVER COVER	
27	062500816	2	ナベコ5X8	SCREW PAN M5X8	
28	SA4537001	1	ダストカバー	DUST COVER	
29	SA4376101	1	シャヘイバン	SHELTER PLATE	
30	SA3065001	1	フェルト	FELT	
31	SA3059101	1	シャヘイバンオサエ	HOLDER, SHELTER PLATE	
32	062500816	1	ナベコ5X8	SCREW PAN M5X8	

C . 針棒搖動關係 / Needle bar rocking mechanism

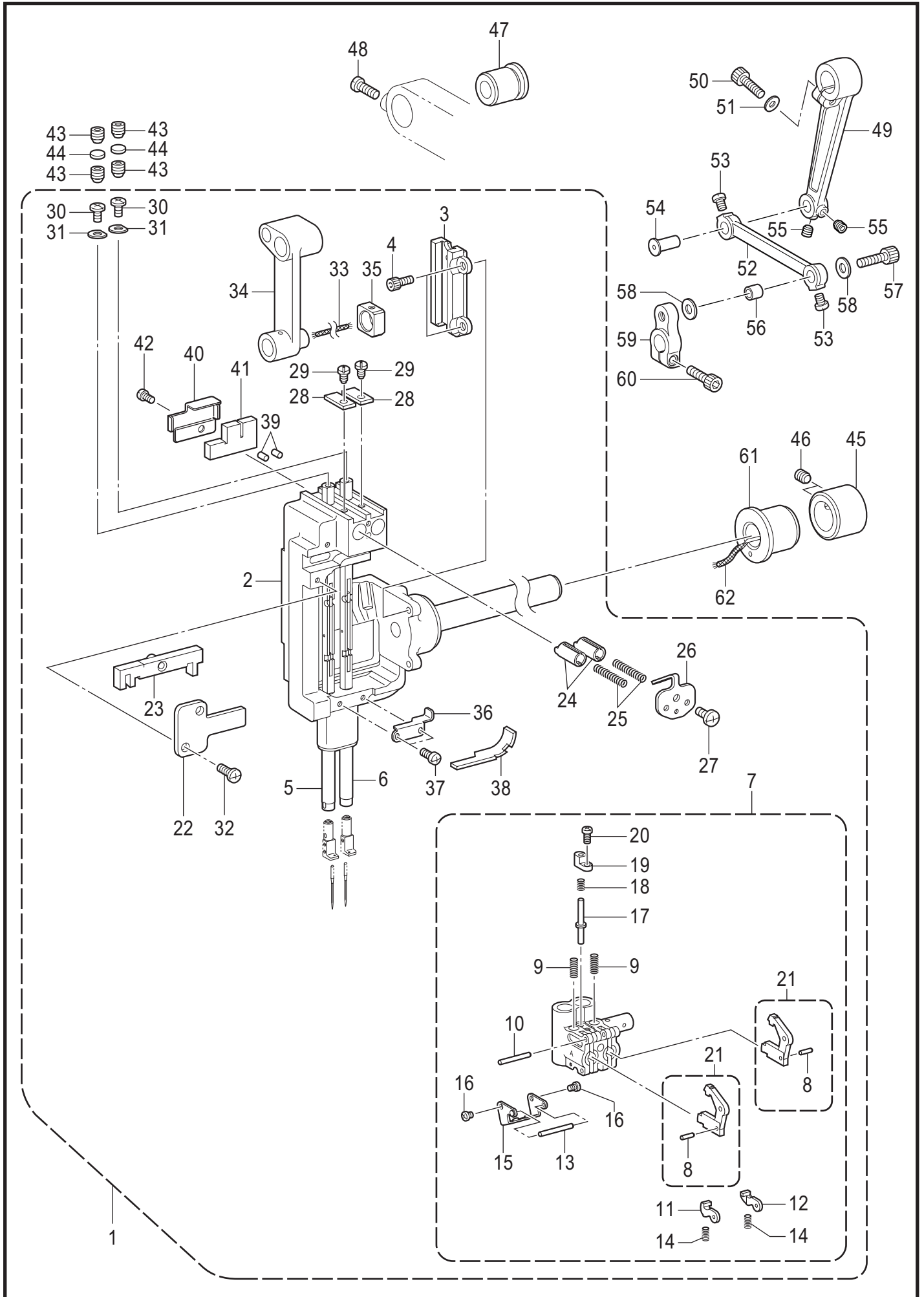

C. 針棒揺動関係 / Needle bar rocking mechanism

REF.NO	CODE	Q'TY	品名	NAME OF PARTS	RM
1	SA8738101	1	ハリボウヨウドウジクソウクミ	NEEDLE BAR ROCKER SHAFT UNIT	
2	SB1434001	1	ハリボウダイクミ	NEEDLE BAR BASE ASSY	
3	SB1425001	1	カクコマスライダ	SLIDE BLOCK SLIDER	
4	018401036	2	アナボルト4X10	BOLT SOCKET M4X10	
5	SA4382001	1	ハリボウLクミ	NEEDLE BAR ASSY L	
6	SA4385001	1	ハリボウRクミ	NEEDLE BAR ASSY R	
7	SA8749001	1	ハリボウダキクミ <記号Z>	NEEDLE BAR CLAMP ASSY <Mark Z>	
8	149604001	2	ピン1.5X5.8	PIN, 1.5X5.8	
9	149605001	2	クラツチテコバネ	SPRING, CLUTCH LEVER	
10	149827001	1	ピン2X15.8	PIN, 2X15.8	
11	S34561101	1	クラツチトメL	CLUTCH STOPPER L	
12	S34562101	1	クラツチトメR	CLUTCH STOPPER R	
13	149608001	1	ピン2X17.8	PIN, 2X17.8	
14	112609001	2	スベリイタストツパバネ	SPRING	
15	SA4391101	1	バネササエ	SPRING HOLDER	
16	062260316	2	ナベコ26X3	SCREW PAN M2.6X3	
17	149610001	1	リリースピン	PIN	
18	149611101	1	リリースピンバネ	SPRING, RELEASE PIN	
19	SA4392001	1	リリースピンフタ	PIN COVER	
20	062260516	1	ナベコ26X5	SCREW PAN M2.6X5	
21	SA4389101	2	クラツチテコクミ	CLUTCH LEVER ASSY	
22	SA4395001	1	スベリコアンナイイタ	SLIDE BLOCK GUIDE PLATE	
			必ず記号を確認後注文のこと	Need check the "Mark" the following parts before ordering.	
23	S07575000	1	スベリコクミ <記号25>	SLIDE BLOCK ASSY, 25 <Mark 25>	
23	S07575001	1	スベリコクミ <記号30>	SLIDE BLOCK ASSY, 30 <Mark 30>	
23	S07575002	1	スベリコクミ <記号35>	SLIDE BLOCK ASSY, 35 <Mark 35>	
23	S07575003	1	スベリコクミ <記号40>	SLIDE BLOCK ASSY, 40 <Mark 40>	
23	S07575004	1	スベリコクミ <記号45>	SLIDE BLOCK ASSY, 45 <Mark 45>	
23	S07575005	1	スベリコクミ <記号50>	SLIDE BLOCK ASSY, 50 <Mark 50>	
23	S07575006	1	スベリコクミ <記号55>	SLIDE BLOCK ASSY, 55 <Mark 55>	
23	S07575007	1	スベリコクミ <記号60>	SLIDE BLOCK ASSY, 60 <Mark 60>	
23	S07575008	1	スベリコクミ <記号65>	SLIDE BLOCK ASSY, 65 <Mark 65>	
23	S07575009	1	スベリコクミ <記号70>	SLIDE BLOCK ASSY, 70 <Mark 70>	
23	S07575010	1	スベリコクミ <記号75>	SLIDE BLOCK ASSY, 75 <Mark 75>	
23	S07575011	1	スベリコクミ <記号80>	SLIDE BLOCK ASSY, 80 <Mark 80>	
24	SA4583001	2	ハリボウストツパー	STOPPER, N-BAR	
25	149622001	2	ハリボウストツパーバネ	SPRING, N-BAR STOPPER	
26	SA4396001	1	バネフタ	SPRING COVER	
27	060350616	1	バインド35X6	SCREW BIND M3.5X6	
28	SA4397001	2	ハリボウマワリトメ	ROTATE STOPPER, N-BAR	
29	SA4398001	2	シメネジ3.5	SCREW, SM3.5	
30	060350616	2	バインド35X6	SCREW BIND M3.5X6	
31	SA4399001	2	ザガネ	WASHER, PLANE	
32	062350816	2	ナベコ35X8	SCREW PAN M3.5X8	
33	112728001	1	クミヒモ	WICK, L=50	
34	SA4393101	1	ハリボウクランクロツド	CRANK ROD, N-BAR	
35	SA4394001	1	カクコマ	SLIDE BLOCK	
36	SA4401001	1	フェルトオサエD	FELT SUPPORT, D	
37	062350516	2	ナベコ35X5	SCREW PAN M3.5X5	
38	SA4400001	1	フェルト	FELT	
39	107155001	2	フェルト	FELT	
40	SA5155001	1	フェルトササエ	FELT SUPPORT	
41	SA5237101	1	フェルト	FELT	
42	062350516	1	ナベコ35X5	SCREW PAN M3.5X5	

C. 針棒搖動關係 / Needle bar rocking mechanism

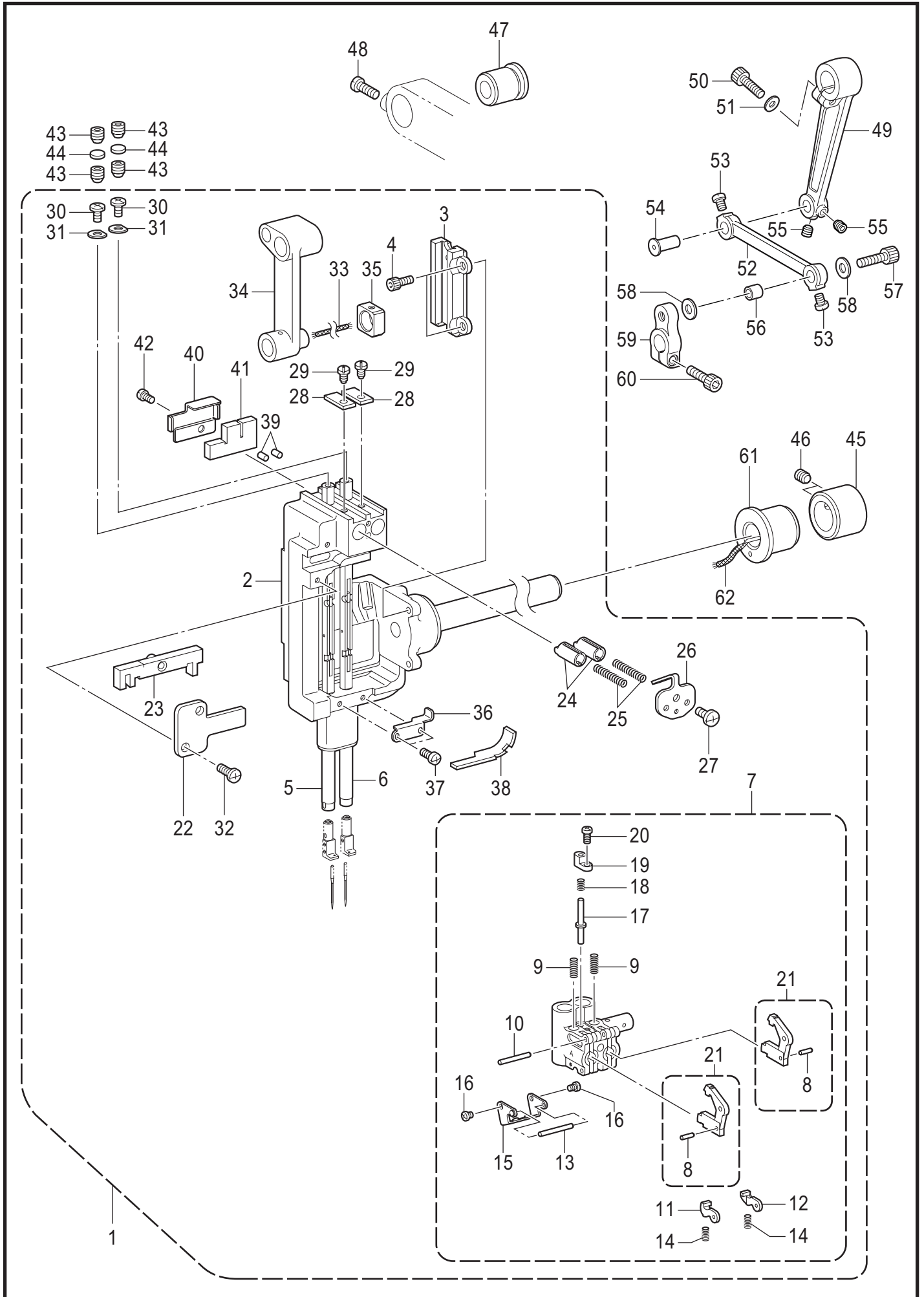

C. 針棒揺動関係 / Needle bar rocking mechanism

REF.NO	CODE	Q'TY	品名	NAME OF PARTS	RM
43	014080831	4	アナクボミ8X8	SET SCREW SOCKET (CP) M8X8	
44	154567000	2	カンザ5.3	SPACER, 5.3	
45	SA2485001	1	セットカラ-	SET SCREW COLLAR	
46	S25260001	2	アナヒラ6X5ホソメ	SET SCREW SOCKET (FT) M6X5	
47	SA2486101	1	ヨウドウジクメタルR	BUSH, R	
48	062061616	1	ナベコ6X16	SCREW PAN M6X16	
49	SA2489001	1	ハリボウヨウドウレバー	NEEDLE BAR ROCKER LEVER	
50	018062032	1	アナボルト6X20	BOLT SOCKET M6X20	
51	118735002	1	ザガネ	WASHER	
52	SA2490101	1	ハリボウヨウドウリンク	ROCKER LINK N-BAR	
53	S23460001	2	ナベコ6X5	SCREW PAN M6X5	
54	SB1437001	1	ヨウドウリンクジク	LINK SHAFT, N-BAR ROCKER	
55	012060636	2	アナヒラ6X6	SET SCREW SOCKET (FT) M6X6	
56	SB1438001	1	ヨウドウリンクカラ-	ZIGZAG LINK BUSH	
57	018062532	1	アナボルト6X25	BOLT SOCKET M6X25	
58	SA2493001	2	ザガネ	WASHER,PLAIN	
59	SA2494001	1	ハリボウヨウドウウデ	NEEDLE BAR ROCK ARM	
60	018062032	1	アナボルト6X20	BOLT SOCKET M6X20	
61	SA5332001	1	ヨウドウジクメタルL	BUSH L	
62	S48204000	1	クミヒモ4X4	WICK, 4X4 L=150	

D. 針棒切換操作關係 / Needle bar flip-up mechanism

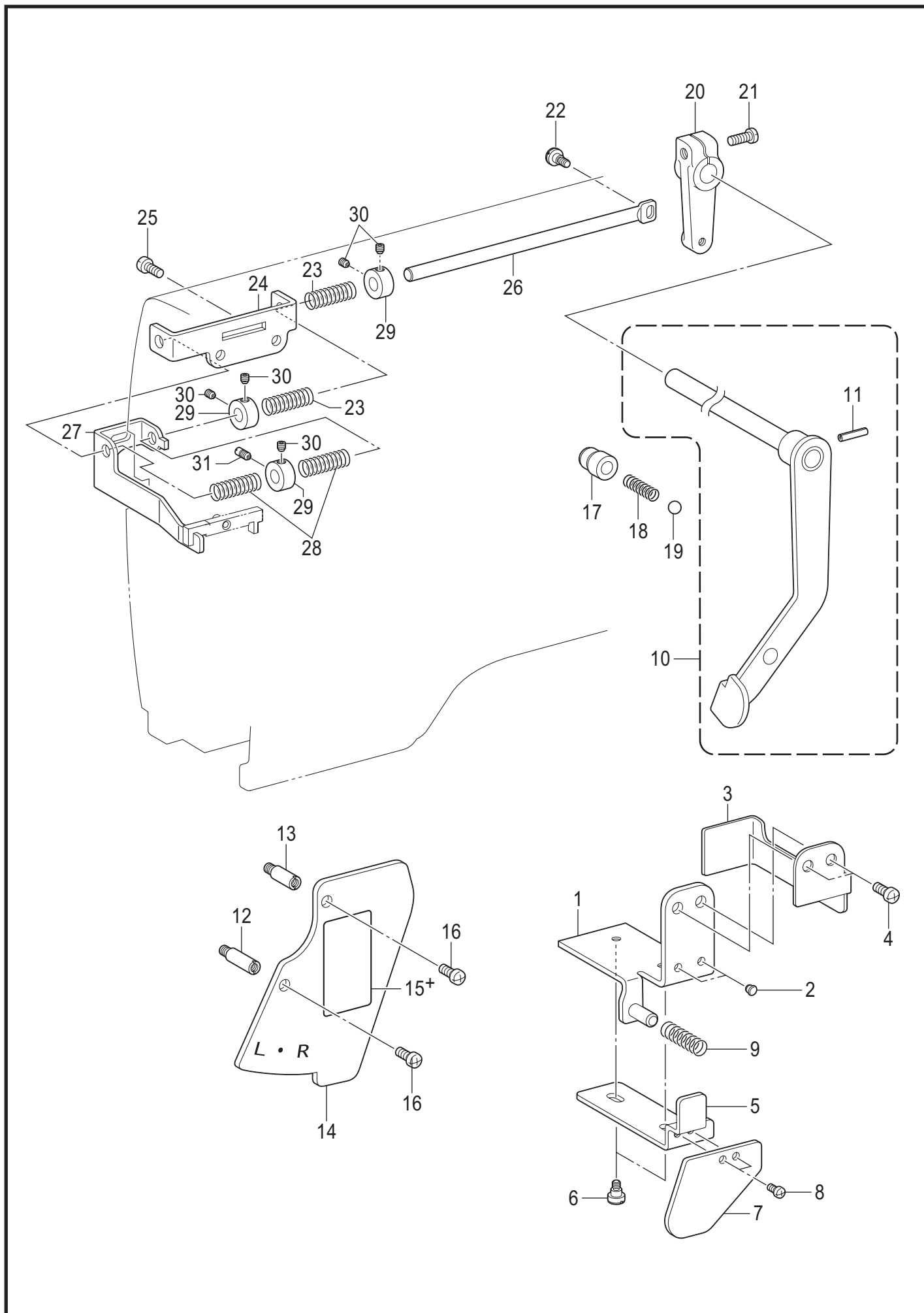

D. 針棒切換操作関係 / Needle bar flip-up mechanism

REF.NO	CODE	Q'TY	品名	NAME OF PARTS	RM
1	SA4402001	1	シジイタクミ	INDICATION PLATE ASSY	
2	104833001	2	ゴムセン4.3	RUBBER CAP, 4.3	
3	SA5336001	1	シジイタカバー	HOLDER PLATE COVER	
4	062501016	2	ナベコ5X10	SCREW PAN M5X10	
5	SA4404001	1	プツシユレバー	PUSH LEVER	
6	SA4441001	2	ダンネジM4	SHOULDER SCREW, M4	
7	SA4405001	1	プツシユレバーイタ	PLATE, PUSH LEVER	
8	062350516	2	ナベコ35X5	SCREW PAN M3.5X5	
9	SA5333001	1	プツシユレバーバネ	SPRING	
10	SA4406001	1	ストップレバージクミ	STOP LEVER SHAFT ASSY	
11	047301842	1	スプリングピンAW3	PIN SPRING ROLL AW3	
12	SA4408001	1	スタッドL	STUD, L	
13	SA4409001	1	スタッドS	STUD, S	
14	SA4411101	1	キリカエシジイタ	FLIP-UP HOLDER PLATE	
15+	S18964001	1	<中国向以外> キリカエシジイタラベル.ワエイ	<Except for China> LABEL	
15+	SA4419001	1	<中国向> キリカエシジイタラベル.チュウエイ	<For China only> LABEL	
16	062500816	2	ナベコ5X8	SCREW PAN M5X8	
17	SA4412001	1	タマアンナイブツシユ	BALL GUIDE BUSH	
18	150820001	1	タマオシバネ	SPRING	
19	071063550	1	コウキユウ1/4	BEARING BALL, 1/4	
20	SA4413001	1	レバージクウデ	ARM LEVER SHAFT	
21	062501416	1	ナベコ5X14	SCREW PAN M5X14	
22	SA5588001	1	ダンネジM4	SHOULDER SCREW, M4	
23	SA4414001	2	レバージクウデバネ	SPRING	
24	SA4415001	1	スライドジクウケ	SLIDE SHAFT BRACKET	
25	062500816	2	ナベコ5X8	SCREW PAN M5X8	
26	S07588101	1	スライドジク	SLIDE SHAFT	
27	SA4416001	1	スライドジクウケイタ	SUPPORT PLATE, SLIDE SHAFT	
28	149863001	2	ジクウケイタバネ	SPRING, PLATE	
29	SA4417001	3	セットカラ-	SET SCREW COLLAR	
30	014400432	5	アナクボミ4X4	SET SCREW SOCKET (CP) M4X4	
31	SA4418001	1	アンナイネジ	GUIDE SCREW	

E . 押え関係 / Presser foot mechanism

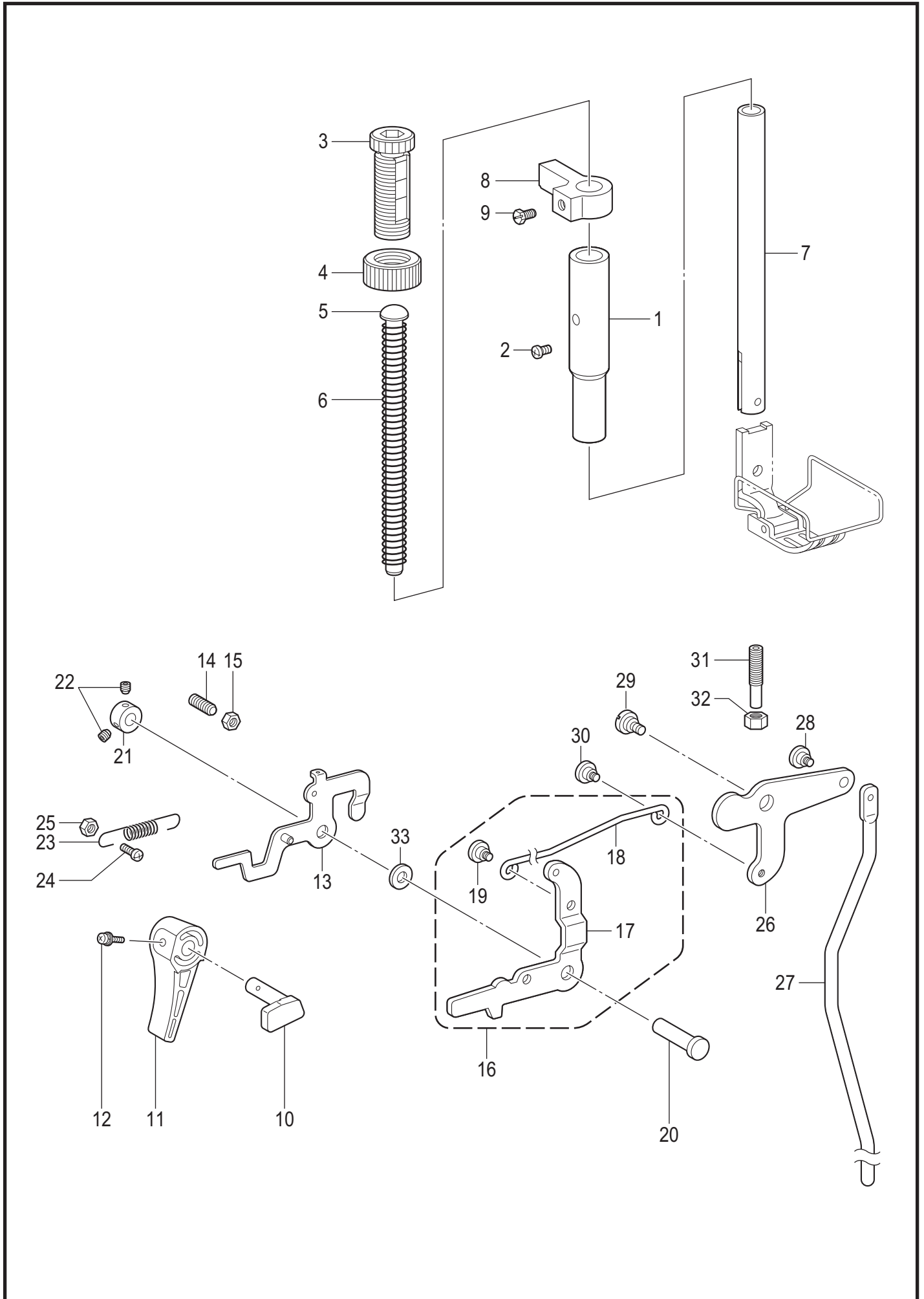

E. 押え関係 / Presser foot mechanism

REF.NO	CODE	Q'TY	品名	NAME OF PARTS	RM
1	SA2495001	1	オサエボウメタル	PRESSER BAR BUSH	
2	062500816	1	ナベコ5X8	SCREW PAN M5X8	
3	SA1174002	1	オサエチヨウセツネジM14	PRESSER ADJUSTING SCREW, M14	
4	SA1175002	1	チヨウセツネジナットM14	ADJUST SCREW NUT	
5	SA7607101	1	オサエバネアンナイ	SPRING GUIDE	
6	S07346101	1	オサエバネ	PRESSER BAR SPRING, -5	
7	SB1439001	1	オサエボウ	PRESSER BAR	
8	SA2498001	1	オサエボウダキ	GUIDE BRACKET, P-BAR	
9	S25289001	1	ボルト6	BOLT (CP) M6X10	
10	SA2499001	1	オサエアゲクランク	PRESSER BAR LIFTING CRANK	
11	S31006002	1	オサエアゲテコ	LIFTING LEVER	
12	S39051001	1	ナベザクミ35X12	SCREW PAN (S/P W) M3.5X12	
13	S07353001	1	イトウルメイタクミ	TENSION RELEASE PLATE ASSY	
14	012061832	1	アナヒラ6X18	SET SCREW, SOCKET (FT) M6X18	
15	021060306	1	3シュナット6	NUT 3 M6	
16	SA2500001	1	ヒザアゲレンカクミ	KNEE LIFTER C-ROD ASSY	
17	SA2501001	1	オサエアゲレバー	PRESSER BAR LIFTING LEVER	
18	SA2502001	1	ヒザアゲレンカン	KNEE LIFTER CONNECTING ROD	
19	SA1179001	1	ダンネジ5	SHOULDER SCREW, M5	
20	S07349001	1	オサエアゲレバージク	P-BAR LIFTING LEVER SHAFT	
21	SA2504001	1	セットカラ	SET SCREW COLLAR	
22	012500536	2	アナヒラ5X5	SET SCREW SOCKET (FT) M5X5	
23	S07355051	1	オサエアゲレバーバネ	SPRING, EXTENSION	
24	062501216	1	ナベコ5X12	SCREW PAN M5X12	
25	021500106	1	1シュナット5	NUT 1 M5	
26	SA2506001	1	ヒザアゲレバー	KNEE LIFTER LEVER	
27	SA2507001	1	ヒザアゲボウ	KNEE LIFTER BAR	
28	SA1179001	1	ダンネジ5	SHOULDER SCREW, M5	
29	SA2165001	1	ダンネジ6	SHOULDER SCREW, M6	
30	SA1179001	1	ダンネジ5	SHOULDER SCREW, M5	
31	SA4149101	1	チヨウセツネジ6	ADJUSTING SCREW, 6	
32	021060306	1	3シュナット6	NUT 3 M6	
33	S07350001	1	ザガネ	WASHER,PLAIN	

F. 送り関係 / Feed mechanism

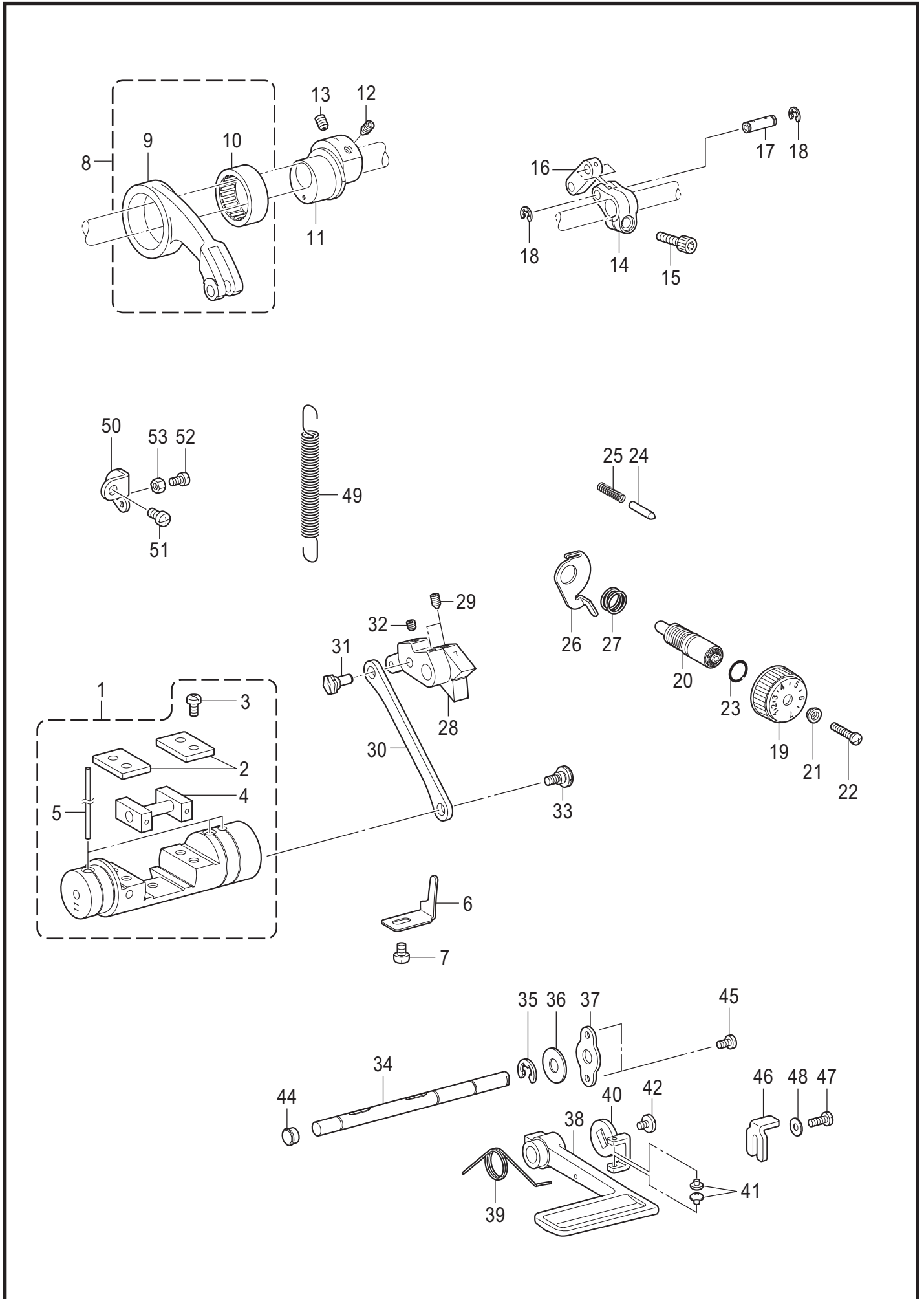

F. 送り関係 / Feed mechanism

REF.NO	CODE	Q'TY	品名	NAME OF PARTS	RM
1	SA3062001	1	キリカエキ11クミ	FEED REGULATOR ASSY, 11	
2	SA2511001	2	カクコマアンナイタ	GUIDE PLATE	
3	062501016	4	ナベコ5X10	SCREW PAN M5X10	
4	SA2512001	1	キリカエキカクコマクミ	SLIDE BLOCK ASSY	
5	SA2515001	3	フェルト	FELT	
6	SA2516001	1	キリカエキトメ	STOPEER	
7	062060816	1	ナベコ6X8	SCREW PAN M6X8	
8	143611201	1	スイヘイオクリレンカンクミ	F-ROCKER CONNECTING ROD ASSY	
9	143612100	1	スイヘイオクリレンカン	FEED ROCKER CONNECTING ROD	
10	118954000	1	ニードルベアリング	NEEDLE BEARING	
11	SA2791001	1	スイヘイヘンシンリン7	LEVEL FEED ECCENTRIC WHEEL 7	
12	SA2585001	1	アナトガリ6X10ホソメ	SET SCREW, SOCKET (FT) M6	
13	S25236001	1	アナヒラ6X10ホソメ	SET SCREW SOCKET (FT) M6X10	
14	SA2793001	1	スイヘイオクリウデ7	FEED ROCKER ARM 7	
15	018062032	1	アナボルト6X20	BOLT SOCKET M6X20	
16	143613051	1	スイヘイオクリウデリンク	LINK	
17	143616001	1	スイヘイオクリウデジク	SHAFT	
18	048060342	2	トメフE6	RETAINING RING E6	
19	S38428002	1	オクリメモリダイヤル	STITCH LENGTH DIAL, 7	
20	SA3056001	1	オクリチヨウセツネジ	FEED REGULATING STUD	
21	142746122	1	メモリイタオサエ	FEED REGULATING SUPPORTER	
22	129458202	1	シメネジ4.76	SCREW, SM4.76	
23	108549001	1	Oリング	O RING	
24	S50098101	1	メモリイチギメピン	POSITIONING PIN	
25	100328001	1	メモリイチキメピンバネ	NOTCH SPRING	
26	SA2523001	1	ダイヤルロックレバー	DIAL LOCK LEVER	
27	S39830101	1	ダイヤルロックレバーバネ	SPRING	
28	SA2796001	1	オクリチヨウセツキ7	FEED REGULATOR 7	
29	016061031	2	アナトガリ6X10	SET SCREW SOCKET (CN) M6X10	
30	SA2526001	1	キリカエキレンカン	CONNECTING ROD	
31	SB1440001	1	ヘンシンジク	ECCENTRIC SHAFT	
32	012060636	1	アナヒラ6X6	SET SCREW SOCKET (FT) M6X6	
33	SB1413001	1	ダンネジ6	SHOULDER SCREW, M6	
34	SA2529101	1	カエシヌイレバー-ジクTR	SHAFT, R-LEVER TR	
35	048080342	1	トメフE8	RETAINING RING E8	
36	025100132	1	ヒラザガネシヨウ10	WASHER PLAIN S 10	
37	SA2530001	1	カンザ	SPACER	
38	S07374209	1	カエシヌイレバー	REVERSE STITCHING LEVER	
39	SA2531001	1	カエシヌイレバー-オサエバネ	SPRING	
40	SA3067001	1	レバーガイド	LEVER GUIDE	
41	S48367000	2	レバーガイドゴム	RUBBER	
42	SA6592001	1	シメネジM5	SCREW M5	
44	104821001	1	ゴムセン10.5	RUBBER CAP, 10.5	
45	062500816	2	ナベコ5X8	SCREW PAN M5X8	
46	SA2532001	1	ハンドルストツパ	STOPPER	
47	062501216	1	ナベコ5X12	SCREW PAN M5X12	
48	025050236	1	ヒラザガネチユウ5	WASHER PLAIN M 5	
49	S07376001	1	キリカエキバネ	FEED REGULATOR SPRING	
50	SA2533001	1	バネカケ	SPRING HOOK	
51	062060816	1	ナベコ6X8	SCREW PAN M6X8	
52	062501216	1	ナベコ5X12	SCREW PAN M5X12	
53	021500106	1	1シユナツト5	NUT 1 M5	

G . 送り軸関係 / Feed shaft mechanism

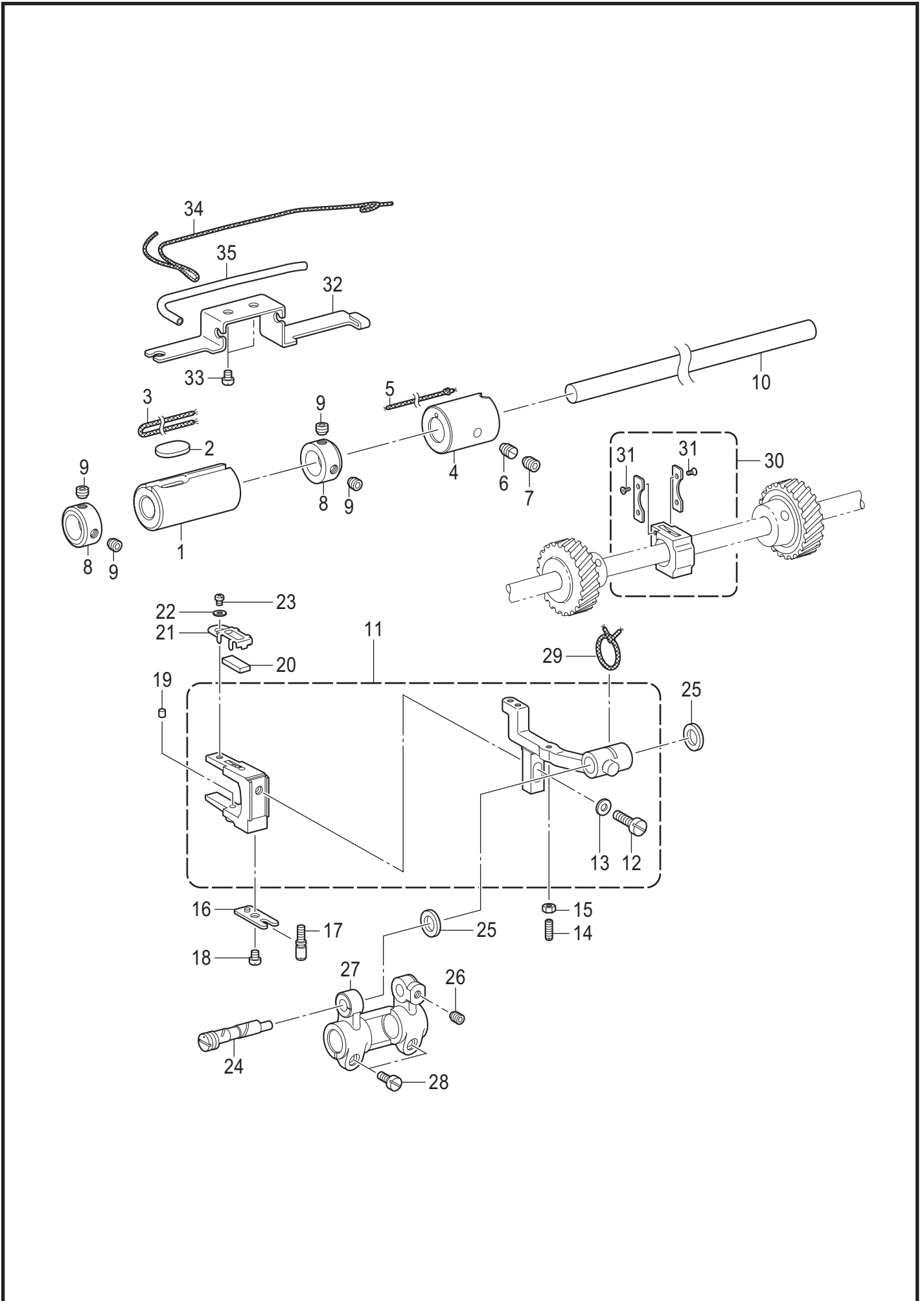

G. 送り軸関係 / Feed shaft mechanism

REF.NO	CODE	Q'TY	品名	NAME OF PARTS	RM
1	SA3855001	1	オクリジクメタルL	BUSH,L:F-ROCKER SHAFT	
2	SA3965001	1	フェルト	FELT	
3	SA4028001	1	クミヒモ4X4 L=220	WICK, 4X4 L=220	
4	SA2543001	1	オクリジクメタルR	FEED ROCKER SHAFT BUSH, R	
5	108802001	1	クミヒモ4X4	WICK, 4X4 L=250	
6	SA2544001	1	トメネジM6	SET SCREW M6	
7	012060636	1	アナヒラ6X6	SET SCREW SOCKET (FT) M6X6	
8	SA2546001	2	セツトカラ-	SET SCREW COLLAR	
9	S23651001	4	アナヒラ6X6ホソメ	SET SCREW SOCKET (FT) M6X6	
10	SA3840001	1	スイヘイオクリジク	FEED ROCKER SHAFT	
11	SA6152101	1	オクリダイSTフタマタクミ	FEED BAR ST FORK ASSY	
12	SA2927001	1	シメネジM6X14	SCREW, M6X14	
13	025060132	1	ヒラザガネショウ6	WASHER PLAIN S 6	
14	SA2566001	1	トメネジ3.5	SET SCREW, M3.5	
15	021350106	1	1シュナット35	NUT 1 M3.5	
16	SA2553001	1	フタマタプレート	FORKED PLATE	
17	SA2554001	1	タカサチヨウセツネジ	ADJUSTING SCREW, HIGHT	
18	062400616	1	ナベコ4X6	SCREW PAN M4X6	
19	SA3990001	1	フェルト	FELT	
20	SA3887001	1	フェルト	FELT	
21	SA3888001	1	フェルトオサエ	FELT HOLDER	
22	025030132	1	ヒラザガネショウ3	WASHER PLAIN S 3	
23	062300416	1	ナベコ3X4	SCREW PAN M3X4	
24	SB1445001	1	オクリダイトリツケジク	FEED BAR SHAFT	
25	SA2551001	2	スラストリング	THRUST RING	
26	012060636	1	アナヒラ6X6	SET SCREW SOCKET (FT) M6X6	
27	SA2555001	1	スイヘイオクリダイウデ	FEED ROCKER BASE ARM	
28	SA2928001	2	シメネジM5X12	SCREW, M5X12	
29	SA4538001	1	クミヒモ3X3 L=200	WICK, 3X3 L=200	
30	SA2806101	1	オクリダイカクコマクミ	FEED BAR SLIDE BLOCK ASSY	
31	SA6308001	4	0サラコ3シュ2X4	SCREW FLAT #0 M2X4	
32	SA4009001	1	クミヒモササエ	WICK SUPPORT	
33	062400616	2	ナベコ4X6	SCREW PAN M4X6	
34	SA2724001	1	クミヒモ	WICK L=400	
35	SA4011001	1	ビニルチューブ L=100	OIL TUBE, L=100	

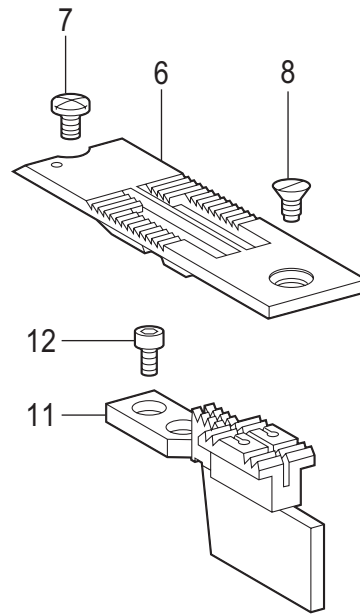
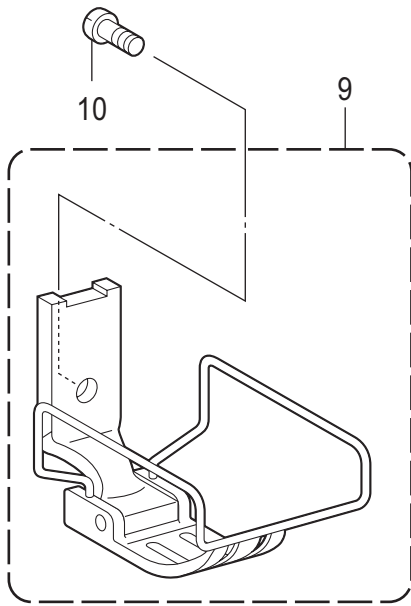
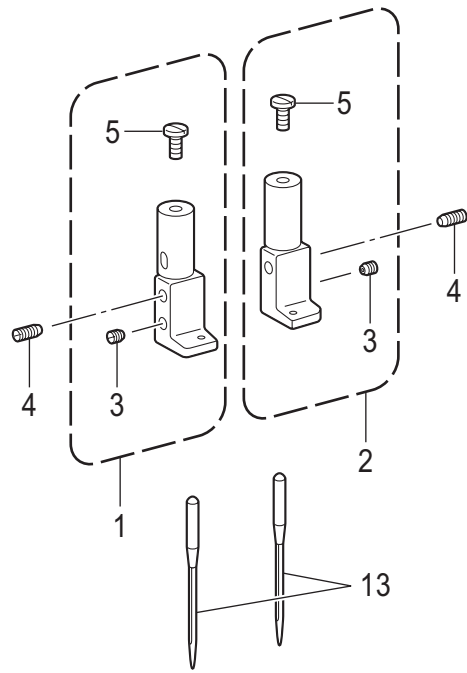

H. ゲージ関係 / Gauge parts

REF.NO	CODE	Q'TY	品名	NAME OF PARTS	RM
1	* P.38-39	1	ハリダキLクミ	NEEDLE CLAMP ASSY,L	
2	* P.38-39	1	ハリダキRクミ	NEEDLE CLAMP ASSY,R	
3	013660412	2	トメクボミ3.18-40X4	SET SCREW (P) SM3.18-40X4	
4	S13085001	2	トメネジ3.18	SET SCREW, SM3.18	
5	149831101	2	アタマツキトメネジ3.18	SET SCREW, SM3.18	
6	* P.38-39	1	ハリイタ	NEEDLE PLATE	
7	S11244001	1	シメネジ4.37	SCREW, SM4.37	
8	100032004	1	サラネジ4.37	SCREW, FLAT SM4.37-40X8	
9	* P.38-39	1	オサエクミ	PRESSER FOOT ASSY	
10	113050001	1	シメネジ3.57	SCREW, SM3.57	
11	* P.38-39	1	オクリバ	FEED DOG	
12	S07494001	2	シメネジ3.18	SCREW, W/ SOCKET SM3.18X7	
13			マシンハリ DPX5...(#22)	NEEDLE DPX5...(#22)	

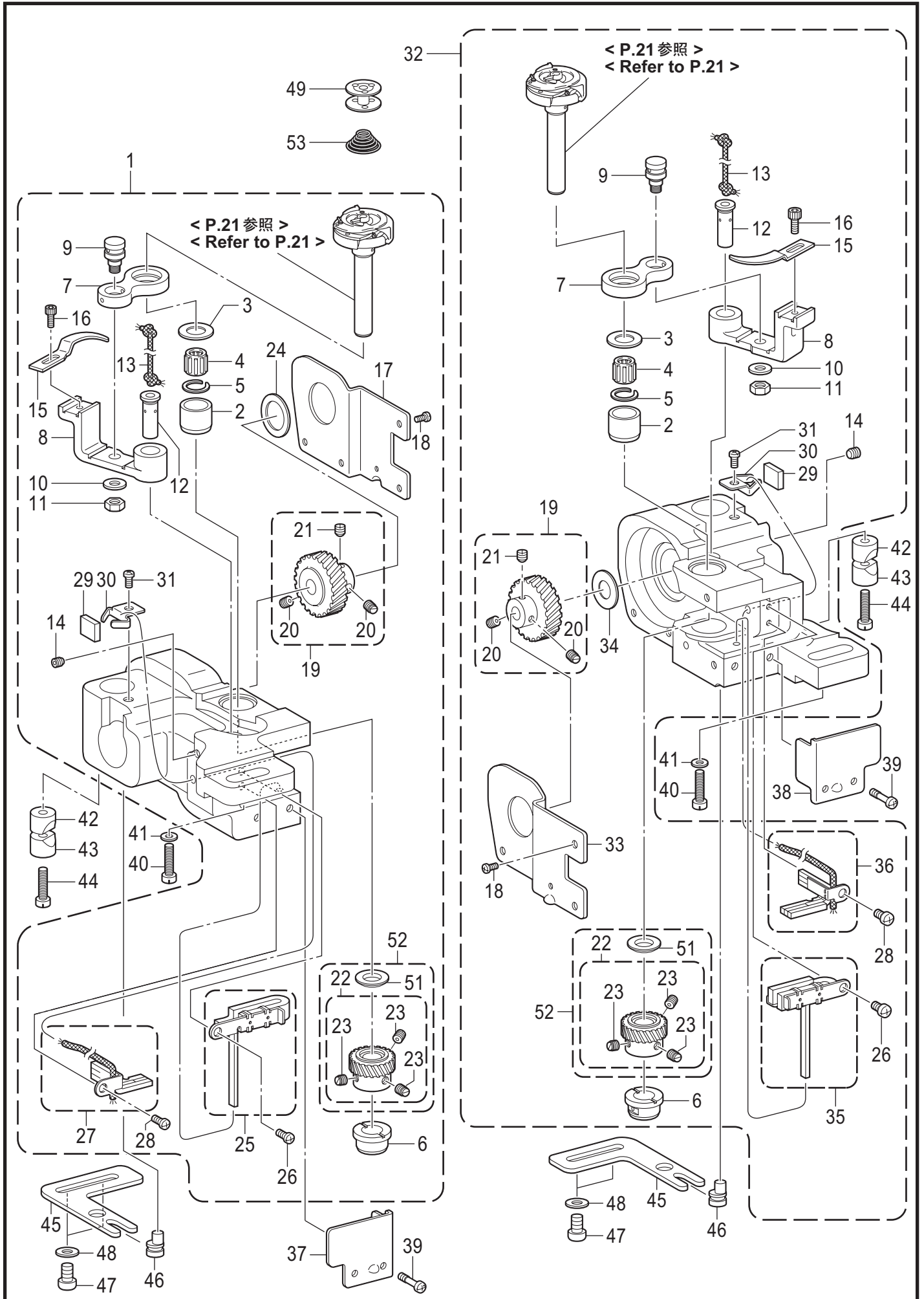

J1. かま関係 / Rotary hook mechanism

REF.NO	CODE	Q'TY	品名	NAME OF PARTS	RM
1	SA4437401	1	カマドダイ875ST(L)クミ	ROTARY HOOK BASE ASSY 875ST(L)	
17	SA2562201	1	カマドダイカバ-L	ROTARY HOOK BASE COVER L	
24	SA3054001	1	スラストザガネL	THRUST WASHER, L	
25	SA6424101	1	フェルトULクミ	FELT UL ASSY	
27	SA4044001	1	フェルトDLクミ	FELT DL ASSY	
37	SA6462001	1	カマドダイカバ-FL	ROTARY HOOK BASE COVER FL	
32	SA4438401	1	カマドダイ875ST(R)クミ	ROTARY HOOK BASE ASSY 875ST(R)	
33	SA2563301	1	カマドダイカバ-R	ROTARY HOOK BASE COVER R	
34	SA2579001	1	スラストザガネ	SPECER	
35	SA6425101	1	フェルトURクミ	FELT UR ASSY	
36	SA4045001	1	フェルトDRクミ	FELT DR ASSY	
38	SA6463001	1	カマドダイカバ-FR	ROTARY HOOK BASE COVER FR	
2	S09259001	2	カマジクメタルU	ROTARY HOOK BUSH, U	
3	S09260001	2	スラストリングA <t=1.2>	THRUST RING, A: 1.2MM <t=1.2>	
3	SA4038001	2	スラストリング <t=1.0>	THRUST RING <t=1.0>	
3	S09261001	2	スラストリングB <t=1.4>	THRUST RING, B: 1.4MM <t=1.4>	
3	SA4444001	2	スラストリング0.8 <t=0.8>	THRUST RING 0.8MM <t=0.8>	
4	S07420000	2	ニードルベアリング	NEEDLE BEARING	
5	S07419001	2	ストツプリング	RETAINING RING	
6	SA6474001	2	カマジクメタルD	ROTARY HOOK SHAFT BUSH	
7	SB1447001	2	オープナーリンク	OPENER LINK	
8	SA3861101	2	オープナーレバー	OPENER LEVER	
9	SA2560001	2	オープナーリンクジク	SHAFT, O-LINK	
10	025710132	2	ヒラザガネシヨウ4.76	WASHER PLAIN S SM4.76	
11	021500316	2	3シュナット5	NUT 3 M5	
12	SA3889101	2	オープナーレバージク	O-LEVER SHAFT	
13	SA4026001	2	クミヒモ4X4 L=100	WICK, 4X4 L=100	
14	012501031	2	アナヒラ5X10	SET SCREW SOCKET (FT) M5X10	
15	S38212001	2	オープナー	OPENER	
16	154965001	2	アナボルト3.57X8	BOLT, SOCKET SM3.57X8	
18	062300612	8	ナベコ3X6	SCREW PAN M3X6	
19	SA2572001	2	スパイラルギア ネジツキ	SPIRAL GEAR SCREW ASSY	
20	SA2574001	4	トメネジM6ホソメ	SET SCREW, (FT) M6	
21	SA2575001	2	トメネジM6ホソメ	SET SCREW, (FT) M6	
22	SA6301001	2	ピニオン ネジツキ	PINION GEAR SCREW ASSY	
23	SA2574001	6	トメネジM6ホソメ	SET SCREW, (FT) M6	
26	062400616	2	ナベコ4X6	SCREW PAN M4X6	
28	062400616	2	ナベコ4X6	SCREW PAN M4X6	
29	SA4012001	2	フェルト	FELT	
30	SA3894001	2	フェルトオサエ	FELT SUPPORT	
31	062400616	2	ナベコ4X6	SCREW PAN M4X6	
51	SA6294101	2	スラストリング	THRUST RING	
52	SA6307101	2	ピニオンセット	PINION GEAR SET	
39	SA6417001	4	シメネジM4X12	SCREW M4X12	
40	SA2556001	2	シメネジM6X25	SCREW, M6X25	
41	115947101	2	ザガネ	WASHER PLAIN 6.35	
42	SA2722001	2	ピンチスリーブA	PINCH SLEEVE A	
43	SA2565001	2	ピンチスリーブB	PINCH SLEEVE B	
44	SA2556001	2	シメネジM6X25	SCREW, M6X25	
45	SA2567001	2	ハリスキチヨウセツイタ	NEEDLE UPPER ADJUSTING PLATE	
46	SA2568001	2	ハリスキチヨウセツジク	NEEDLE UPPER POSITIONING SHAFT	
47	062061016	4	ナベコ6X10	SCREW PAN M6X10	
48	025060136	4	ヒラザガネシヨウ6	WASHER PLAIN S 6	
49	S09285051	2	ボビン	BOBBIN	
53	156557001	2	クウテンボウシバネ	ANTI-SPIN SPRING	

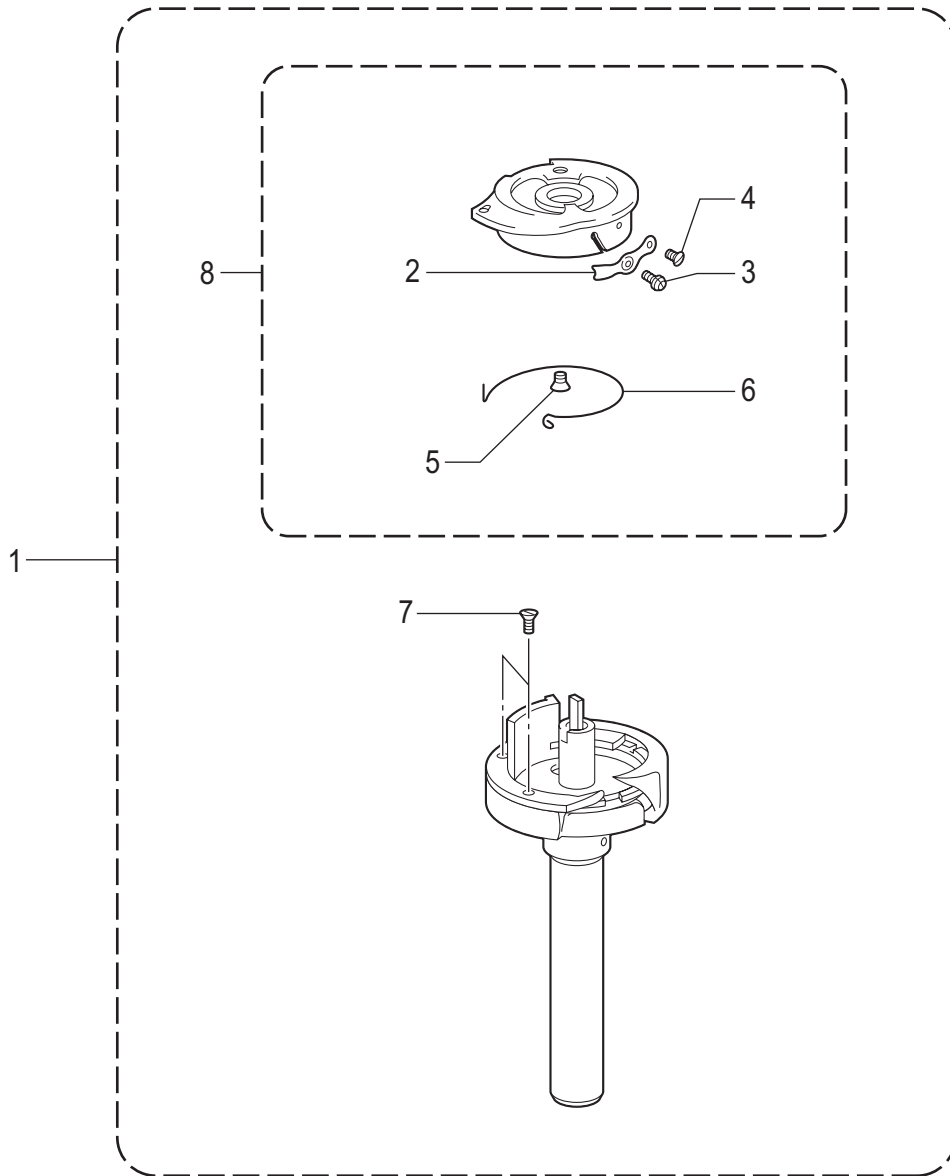

J2. かま関係 / Rotary hook mechanism

REF.NO	CODE	Q'TY	品名	NAME OF PARTS	RM
1	SB0771001	1	カマハコクミ	ROTARY HOOK BOX ASSY	
2	155479001	1	チヨウシバネ	TENSION SPRING	
3	151029001	1	チヨウシネジ	TENSION ADJUSTING SCREW	
4	151030001	1	チヨウシバネトメネジ	SET SCREW	
5	151035001	1	タルミトリバネトメネジ	SET SCREW	
6	155478001	1	シタイトタルミトリバネ	TENSION SPRING	
7	151027001	2	ウチカマオサエトメネジ	SET SCREW	
8	S09279001	1	キャップクミ	CAP ASSY	

K . 下軸関係 / Lower shaft mechanism

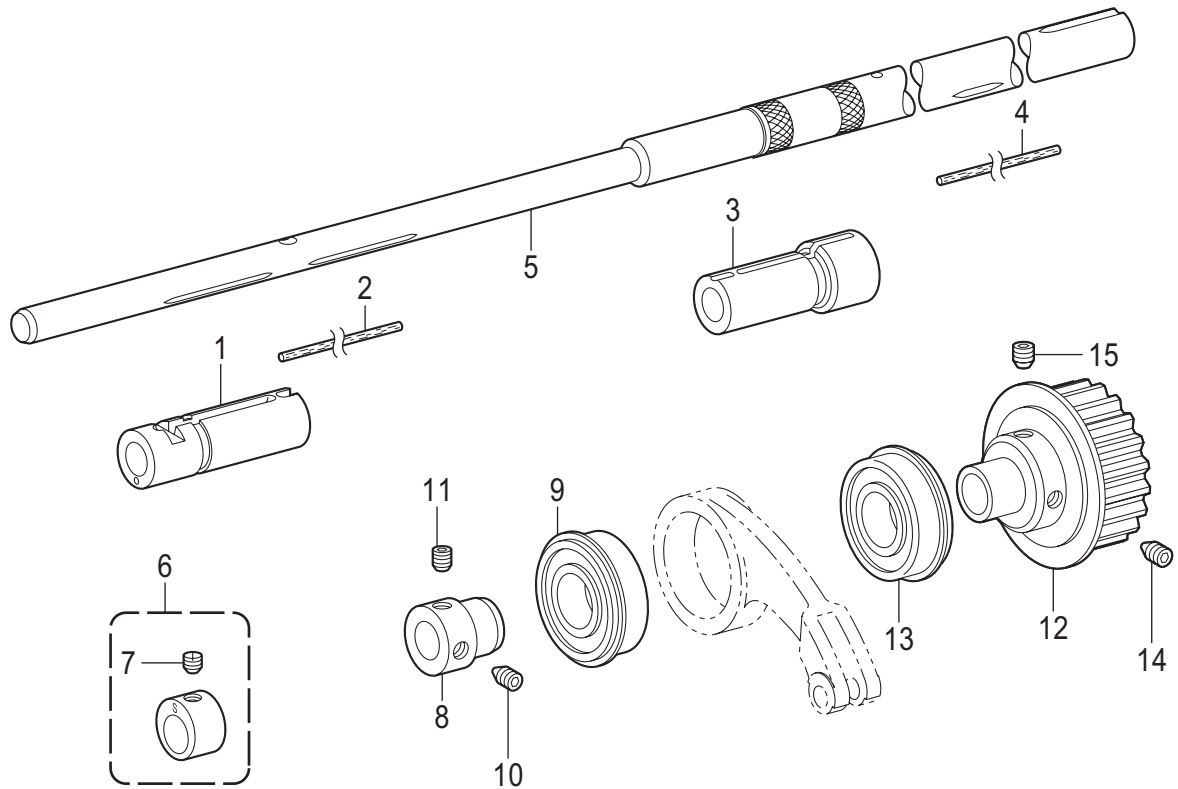

K. 下軸関係 / Lower shaft mechanism

REF.NO	CODE	Q'TY	品名	NAME OF PARTS	RM
1	SA3890001	1	カマドダイメタルL	ROTARY HOOK BASE BUSH, L	
2	SA4585001	1	フェルト	FELT	
3	SA3891001	1	カマドダイメタルR	ROTARY HOOK BASE BUSH, R	
4	SA4585001	1	フェルト	FELT	
5	SA2571101	1	シタジク	LOWER SHAFT	
6	SA2759101	1	ジヨウゲヘンシンリンSTクミ	F-LIFTING ECCENTRIC WHEEL ASSY	
7	SA2575001	1	トメネジM6ホソメ	SET SCREW, (FT) M6	
8	SA2584001	1	タマジクウケブツシュ	BALL BEARING BUSH	
9	SB1484001	1	タマジクウケ6004ZZ NR	BALL BEARING, 6004ZZ NR	
10	SA2585001	1	アナトガリ6X10ホソメ	SET SCREW, SOCKET (FT) M6	
11	S23651001	1	アナヒラ6X6ホソメ	SET SCREW SOCKET (FT) M6X6	
12	SA2587101	1	タイミングプーリDクミ	TIMING PULLEY ASSY, D	
13	SB1536001	1	タマジクウケ6204ZZNR	BALL BEARING, 6204ZZNR	
14	SA2585001	1	アナトガリ6X10ホソメ	SET SCREW, SOCKET (FT) M6	
15	SA4213001	1	アナトメネジ6X10ホソメ	SET SCREW, SOCKET (CP) M6X10	

L . 給油潤滑關係 / Lubrication

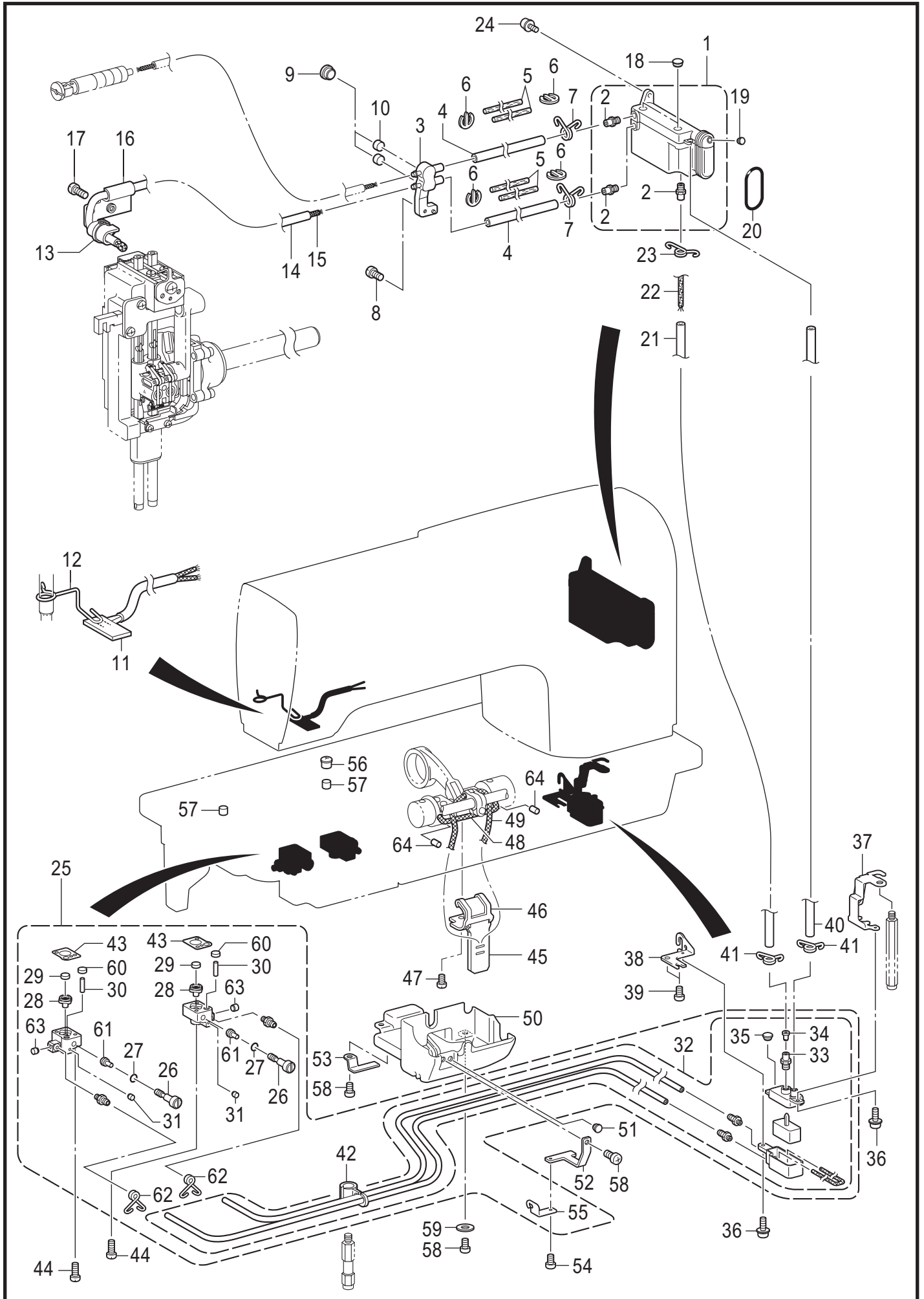

L. 給油潤滑関係 / Lubrication

REF.NO	CODE	Q'TY	品名	NAME OF PARTS	RM
1	SA2814201	1	オイルタンククミ	OIL TANK ASSY	
2	SA3040001	3	オイルクチ	OIL FEEDING PIPE	
3	SA3946001	1	キュウユタ-ミナル	OIL TERMINAL	
4	SA2956001	2	ビニルチューブ	OIL TUBE, L=135	
5	SA2957001	4	フェルト	FELT	
6	SA6178001	4	クリップ	CLIP	
7	SA3055101	2	チューブストツパー	TUBE CLIP	
8	062500816	1	ナベコ5X8	SCREW PAN M5X8	
9	SA2929001	2	ゴムセン12.5	RUBBER CAP, 12.5	
10	S38266000	2	カマジクフェルト	ROTARY HOOK SHAFT FELT	
11	SA5224001	1	フェルトクミ	FELT ASSY	
12	SA4033101	1	フェルトオサエ	FELT SUPPORT	
13	228475000	1	ケツソクバンド1.9X80	FASTENING BAND 1.9X80	
14	S49623000	1	ビニルチューブ	OIL TUBE, L=280	
15	SA5293001	1	クミヒモ	WICK L=410	
16	SA5154201	1	キュウユササエ	OIL SUPPORT	
17	062501016	1	ナベコ5X10	SCREW PAN M5X10	
18	SA2929001	2	ゴムセン12.5	RUBBER CAP, 12.5	
19	104450101	1	ゴムセン8	RUBBER CAP, 8	
20	081038070	1	OリングP38	O RING P38	
21	SA2723001	1	ビニルチューブ	OIL TUBE, L=210	
22	SA2724001	1	クミヒモ	WICK, L=400	
23	SA3055101	1	チューブストツパー	TUBE CLIP	
24	0A5501006	2	+ナベザクミ5X10DB	SCREW PAN (S/P WASHER) M5X10	
25	SA7540001	1	キュウユブロッツクセット	OIL BLOCK SET	
26	SA6475001	2	オイルチヨウセツネジ	OIL ADJUSTING SCREW	
27	081004070	2	OリングP4	O RING P4	
28	SA6468001	2	ゴムパツキン	RUBBER PACKING	
29	SA6423001	2	カマジクフェルト	ROTARY HOOK SHAFT FELT	
30	SA6415001	2	クミヒモ	WICK L=80	
31	142274101	2	ゴムセン4.2	RUBBER CAP, 4.2	
32	SA7548001	1	サブタンクセット	SUB-TANK SET	
33	SA3040001	1	オイルクチ	OIL FEEDING PIPE	
34	SA3060001	1	バルブパツキン	VALVE PACKING	
35	104450101	1	ゴムセン8	RUBBER CAP, 8	
36	0A4400806	2	+ナベザクミ4X8DA	SCREW PAN (S/P WASHER) M4X8	
37	SA3045201	1	サブタンクトリツケイタA	SUB-TANK SETTING PLATE A	
38	SA3046001	1	サブタンクトリツケイタB	SUB-TANK SETTING PLATE, B	
39	062060816	2	ナベコ6X8	SCREW PAN M6X8	
40	SA3044001	1	ビニルチューブ	OIL TUBE, L=242	
41	SA3055101	2	チューブストツパー	TUBE CLIP	
42	SA6472001	1	チューブササエ	TUBE SUPPORT	
43	SA3923101	2	カマドダイDパツキン	ROTARY HOOK BASE D PACKING	
44	062401616	4	ナベコ4X16	SCREW PAN M4X16	
45	SA2604001	1	キリカエキフェルト	FEED REGULATOR FELT	
46	SA2605001	1	フェルトオサエイタ	FELT SUPPORT	
47	062500616	1	ナベコ5X6	SCREW PAN M5X6	
48	109405001	1	クミヒモ4X4	WICK 4X4 (L=100)	
49	108801001	1	クミヒモ4X4	WICK, 4X4 L=350	
50	SA2606101	1	オイルカバー	OIL COVER	
51	104450101	1	ゴムセン8	RUBBER CAP, 8	
52	SA3048101	1	チューブオサエA	TUBE SUPPORT, A	
53	SA3049001	1	チューブオサエB	TUBE SUPPORT, B	
54	062400616	1	ナベコ4X6	SCREW PAN M4X6	
55	SA6473001	1	チューブガイド	TUBE GUIDE	
56	140890009	1	オイルカツプ	OIL CAP	
57	112753001	2	フェルト	FELT	
58	062061016	3	ナベコ6X10	SCREW PAN M6X10	
59	025060236	1	ヒラザガネチュウ6	WASHER PLAIN M 6	
60	SA6423001	2	カマジクフェルト	ROTARY HOOK SHAFT FELT	

L . 給油潤滑關係 / Lubrication

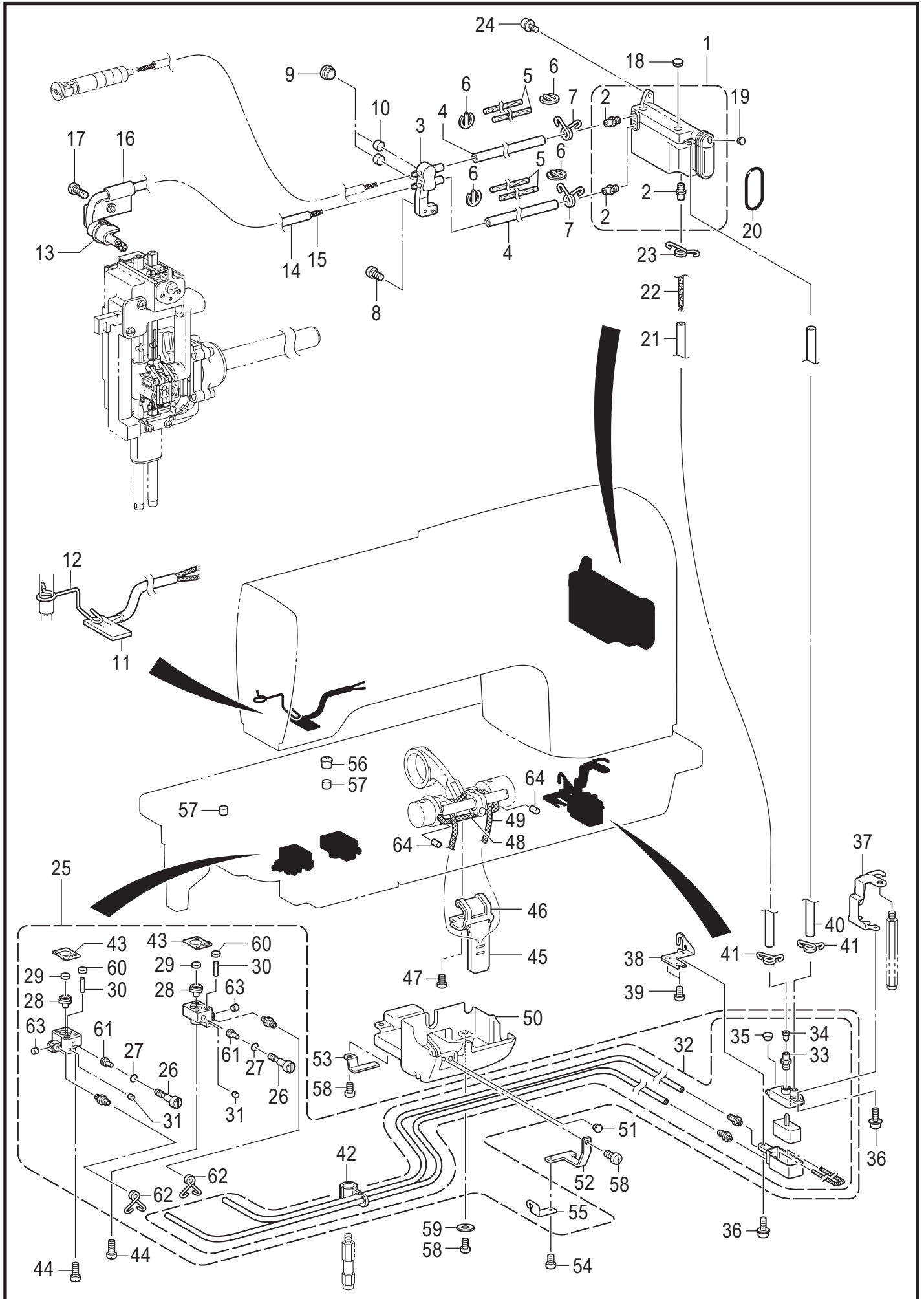

L. 給油潤滑関係 / Lubrication

REF.NO	CODE	Q'TY	品名	NAME OF PARTS	RM
61	SA6416001	2	ゴムオサエ	RUBBER PRESSER	
62	SA6414001	2	チューブストツパー	TUBE CLIP	
63	140327001	2	ゴムセン6.3	RUBBER CAP, 6.3	
64	148743001	2	フェルト	FELT	

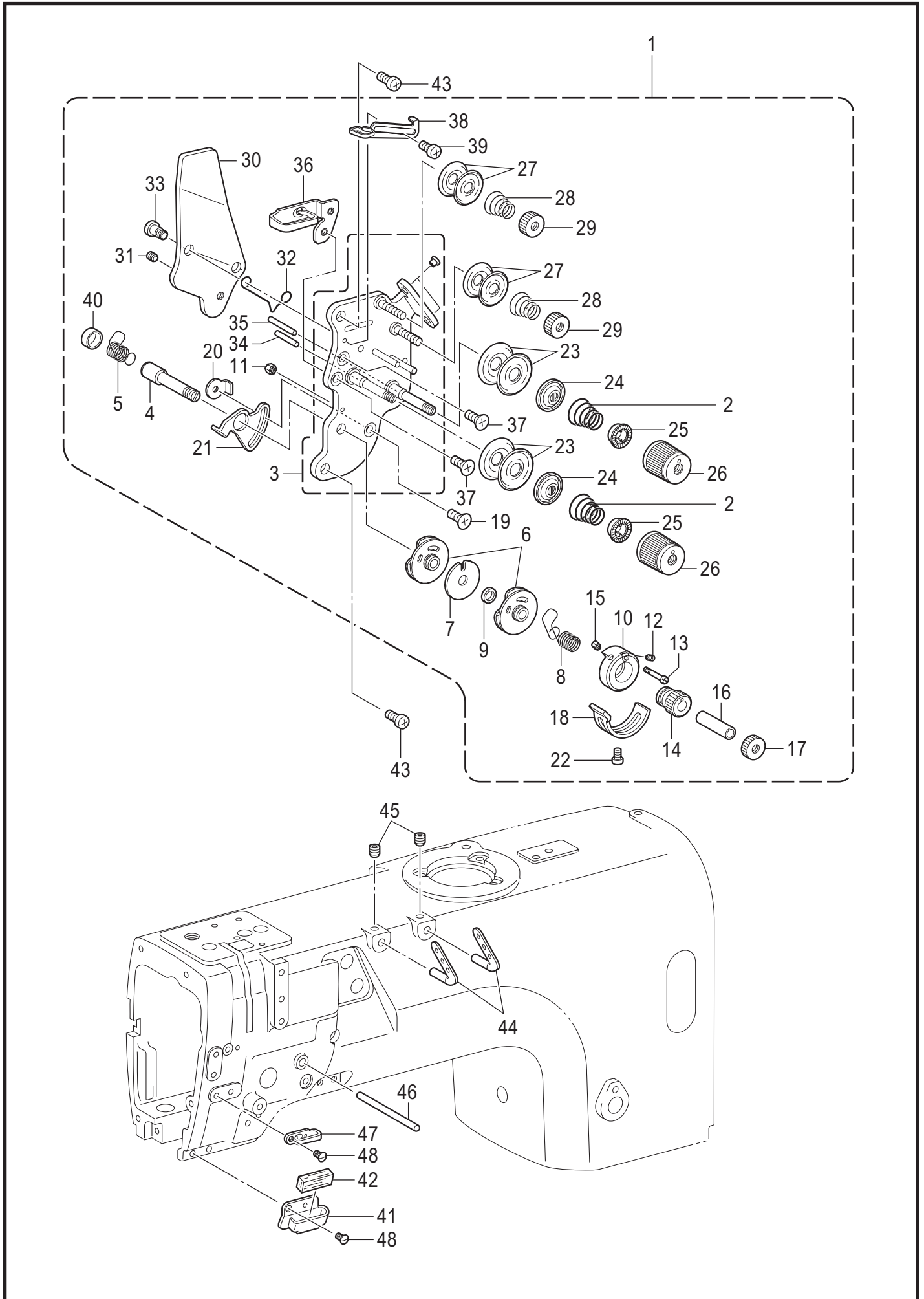

M. 糸通し関係 / Threading mechanism

REF.NO	CODE	Q'TY	品名	NAME OF PARTS	RM
1	SA2607401	1	ウワイトチヨウシクミ-5	UPPER THREAD TENSION ASSY -5	
2	SA3416101	2	イトチヨウシバネLL	TENSION SPRING LL	
3	SA4212001	1	イトチヨウシダイクミ	TENSION PLATE ASSY	
4	SA2613001	1	チヨウシジク	TENSION STUD	
5	SA2614201	1	イトトリバネL	THREAD TAKE-UP SPRING, L	
6	SA2615001	2	イトトリバネアンナイクミ	GUIDE ASSY, T/TAKE-UP SPRING	
7	SA2619001	1	スペーサ-	SPACER	
8	SA2623201	1	イトトリバネR	THREAD TAKE-UP SPRING R	
9	SA2620001	1	カラ-	COLLAR	
10	SA2621001	1	ストツパウケ	STOPPER SUPPORT	
11	021300106	1	1シュナツ3	NUT 1 M3	
12	SA2626001	1	トメネジ3.5	SET SCREW, (CP) M3.5	
13	SA2624001	1	バネアンナイトメネジ	SPRING GUIDE SET SCREW	
14	SA2625001	1	チヨウセツツマミ	ADJUSTING THUMB	
15	SA2626001	1	トメネジ3.5	SET SCREW, (CP) M3.5	
16	SA2627001	1	カラ-	COLLAR	
17	SA2628001	1	イトチヨウシナツト	TENSION NUT	
18	SA2629001	1	イトトリバネストツパ	STOPPER	
19	004350616	1	+サラコ3.5X6	SCREW FLAT M3.5X6	
20	SA2824001	1	マワリドメナツトM3.5	NUT, WHIRL-STOP M3.5	
21	SA2630001	1	イトトリバネストツパ	STOPPER	
22	062350512	1	ナベコ35X5	SCREW PAN M3.5X5	
23	145446001	4	イトチヨウシサラ	DISC, TENSION	
24	159805001	2	イトチヨウシサラオサエ	TENSION DISC PRESSER	
25	S20681000	2	チヨウシバネウエザガネ	WASHER	
26	S20682111	2	イトチヨウシナツト	TENSION NUT	
27	144504001	4	イトアンナイサラ	THREAD GUIDE DISC	
28	154560101	2	プレテンションバネA	PRE-TENSION SPRING A	
29	155510001	2	イトチヨウシナツト	TENSION NUT	
30	SA2632001	1	イトユルメイタ	TENSION RELEASE PLATE	
31	012500536	1	アナヒラ5X5	SET SCREW SOCKET (FT) M5X5	
32	S38274001	1	イトユルメバネ	T-RELEASE SPRING	
33	SA2633001	2	ダンネジ3.5	SHOULDER SCREW, M3.5	
34	SA4506001	1	イトユルメピンL	TENSION RELEASE PIN, L	
35	SA4507001	1	イトユルメピンR	TENSION RELEASE PIN, R	
36	SA2634001	1	ア-ムイトアンナイU	THREAD GUIDE, U: ARM	
37	004350616	2	+サラコ3.5X6	SCREW FLAT M3.5X6	
38	SA2635001	1	イトリヨウチヨウセイ	THREAD QUANTITY ADJUST	
39	062300616	1	ナベコ3X6	SCREW PAN M3X6	
40	SA6378001	1	キャツブ	CAP	
41	SA2639001	1	ア-ムイトアンナイD	THREAD GUIDE, D: ARM	
42	114941001	1	ア-ムイトアンナイフェルト	FELT	
43	062500816	2	ナベコ5X8	SCREW PAN M5X8	
44	SA2636001	2	ミツメイトカケ	THREAD RETAINER	
45	012060636	2	アナヒラ6X6	SET SCREW SOCKET (FT) M6X6	
46	SA2637001	1	イトユルメジク	BAR, TENSION RELEASE	
47	SA2638001	1	ア-ムイトアンナイM	THREAD GUIDE, M: ARM	
48	SA2640001	2	サラネジ5X8	SCREW FLAT M5X8	

N . 糸巻関係 / Bobbin winder mechanism

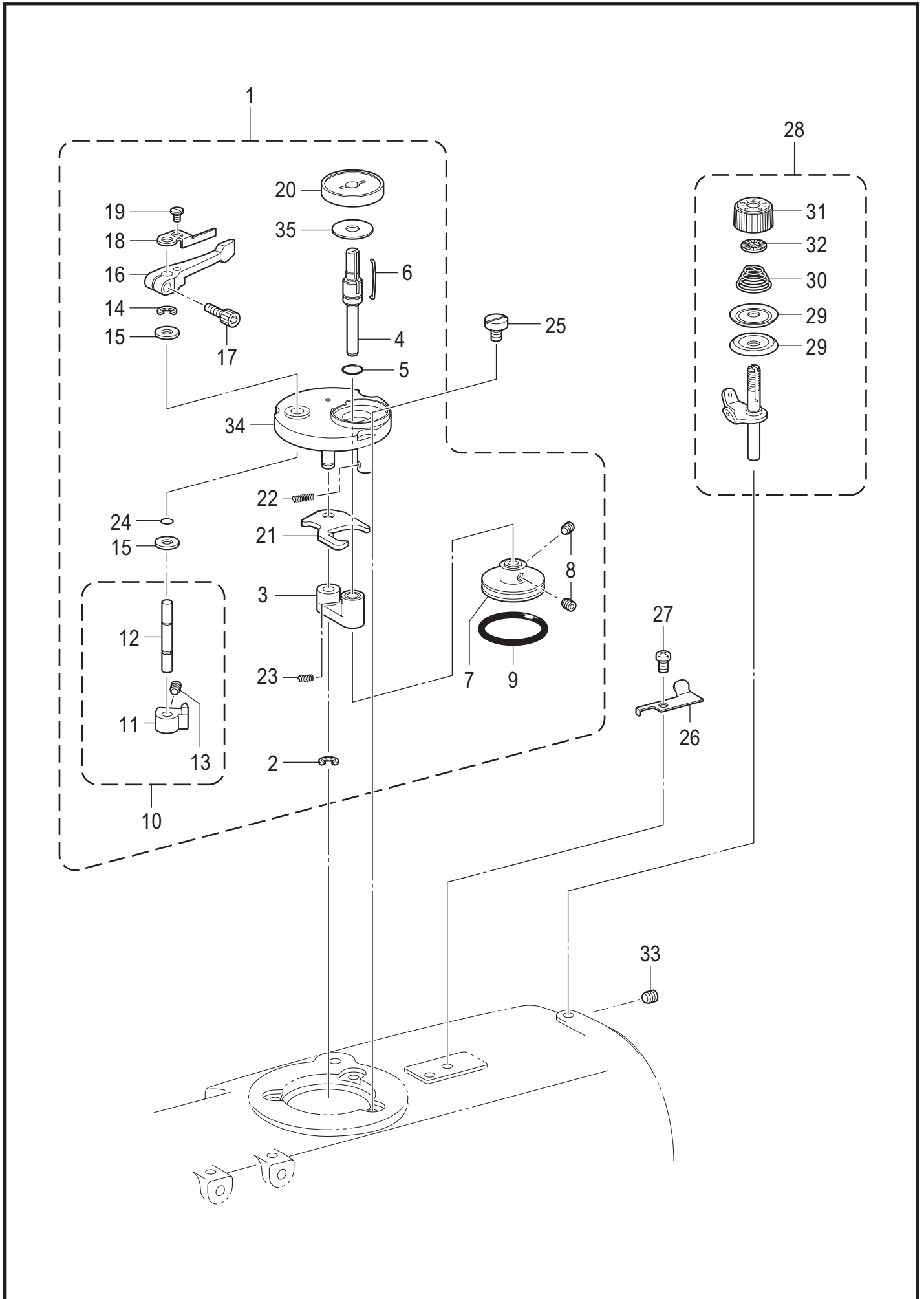

N. 糸巻関係 / Bobbin winder mechanism

REF.NO	CODE	Q'TY	品名	NAME OF PARTS	RM
1	SA1971502	1	イトマキユニット	BOBBIN WINDER UNIT	
2	048040342	1	トメワE4	RETAINING RING, E4	
3	SA8508001	1	イトマキジクウケクミ	B-WINDER SHAFT SUPPORT ASSY	
5	108549001	1	Oリング	O RING	
4	SA8511101	1	イトマキジク	BOBBIN WINDER SHAFT	
35	SB1639001	1	シート	SHEET	
6	SA9563001	1	ボビンコティバネ	BOBBIN FIXED SPRING	
7	SA8507001	1	イトマキクルマ	BOBBIN WINDER WHEEL	
8	012400636	2	アナヒラ4X6	SET SCREW SOCKET (FT) M4X6	
9	SA8503001	1	ゴムリング	RUBBER RING	
10	SA1981301	1	ボビンオサエカムクミ	BOBBIN PRESSER CAM ASSY	
11	SA1982101	1	ボビンオサエカム	BOBBIN PRESSER CAM	
12	SA1983201	1	イトマキウデジク	BOBBIN WINDER ARM SHAFT	
13	012500536	1	アナヒラ5X5	SET SCREW SOCKET (FT) M5X5	
14	048040342	1	トメワE4	RETAINING RING E4	
15	025060136	2	ヒラザガネシヨウ6	WASHER PLAIN S 6	
16	SA1984001	1	ボビンオサエウデ	BOBBIN PRESSER ARM	
17	018401236	1	アナボルト4X12	BOLT SOCKET M4X12	
18	SA1985001	1	ボビンオサエ	BOBBIN PRESSER	
19	S23418002	1	シメネジ4X5	SCREW M4X5	
20	SA8510101	1	ボビンウケ	BOBBIN SUPPORT	
21	SA8512101	1	イトマキレバー	BOBBIN WINDER LEVER	
22	SA1990101	1	モドシバネ	SPRING	
23	SA8509001	1	イトマキダイバネ	BOBBIN WINDER BASE SPRING	
24	SA2190001	1	OリングSS5	O RING, SS5	
25	SA1992101	3	イトマキコティネジ	BOBBIN WINDER FIXED SCREW	
26	SA1360101	1	メス	KNIFE	
27	062500616	1	ナベコ5X6	SCREW, PAN M5X6	
28	SA1994102	1	イトマキチヨウシクミ	BOBBIN WINDER TENSION ASSY	
29	145446002	2	イトチヨウシサラ	DISC, TENSION	
30	100401022	1	イトチヨウシバネ	TENSION SPRING	
31	S31032002	1	イトチヨウシナツト	TENSION NUT	
32	S12441001	1	チヨウシバネウエザガネ	WASHER	
33	012500536	1	アナヒラ5X5	SET SCREW, SOCKET (FT) M5X5	
34	SA8982202	1	イトマキダイ	BOBBIN WINDER BASE	

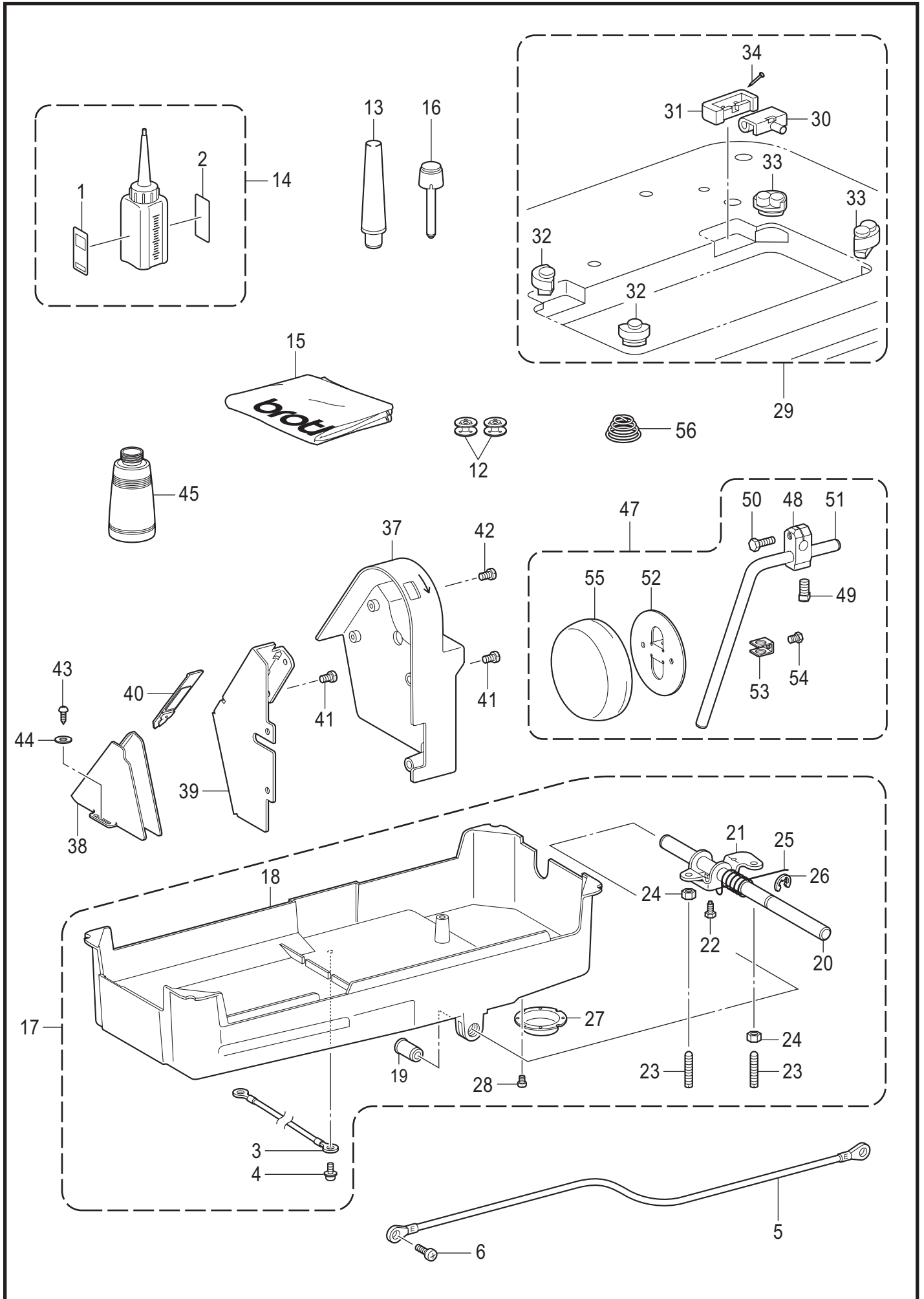

Z1. 付属品関係 / Accessories



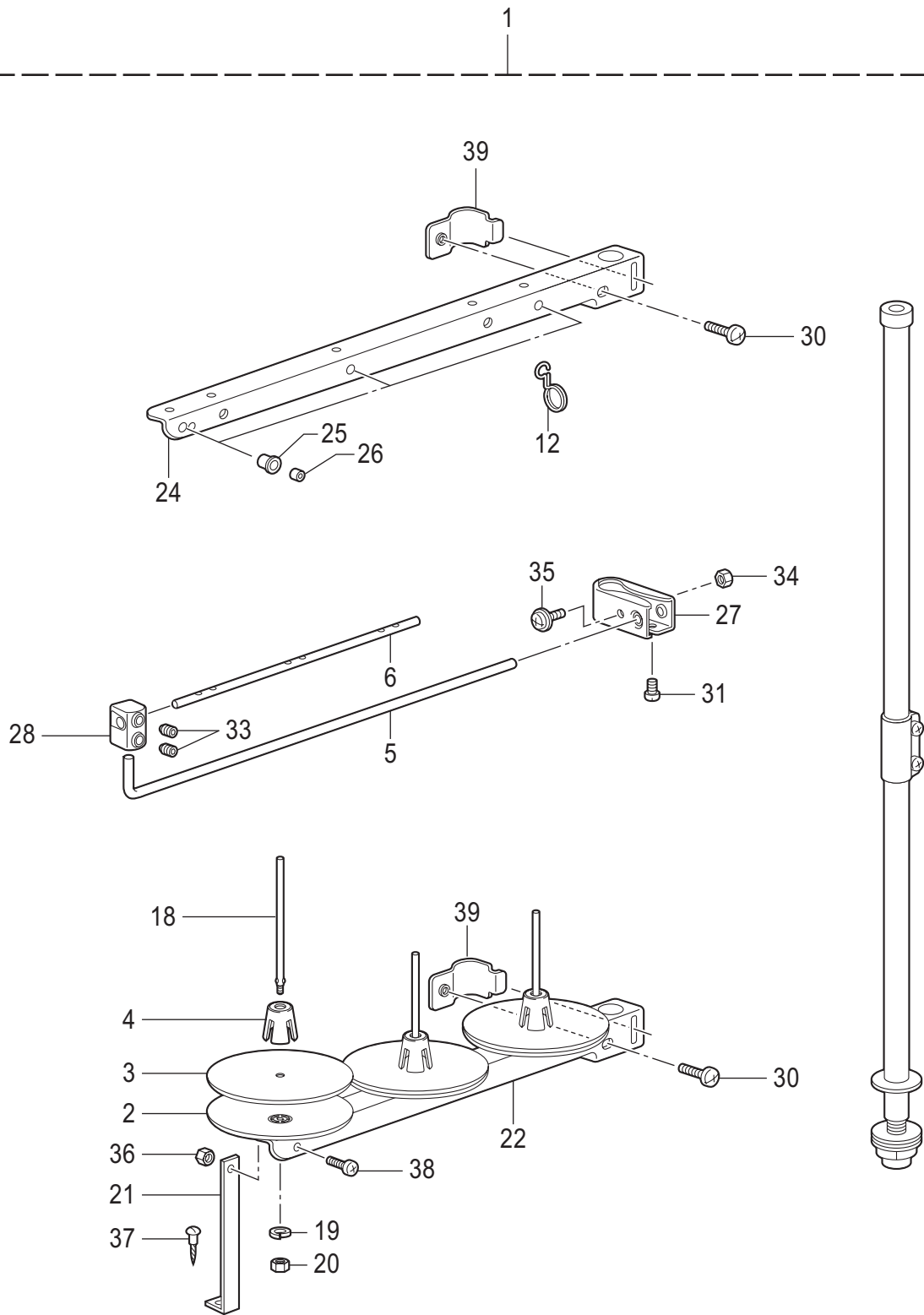

REF.NO	CODE	Q'TY	品名	NAME OF PARTS	RM
12	S09285051	2	ボビン	BOBBIN	
13	100477009	1	マクラ	HEAD REST	
14	SA8239201	1	オイルタンククミ	OIL TANK ASSY	
1	SB1271001	1	オイルケイコクラベル ワブン	OIL WARNING LABEL JP	
2	SB1270001	1	オイルケイコクラベル エイブン	OIL WARNING LABEL EN	
15	144226001	1	トウブカバー	HEAD COVER	
16	145573000	1	ヒザアゲオシボウ	KNEE LIFTER COMPLYING BAR	
17	SB1414001	1	オイルパンソウクミ	OIL PAN UNIT	
18	SA2692101	1	アブラウケ	OIL PAN	
19	149578000	2	ヨコジクブツシュ	BUSH	
20	SA2582001	1	ヒザアゲヨコジク	KNEE LIFTER SHAFT	
21	SA2590001	1	ヒザアゲ	KNEE LIFTER	
22	S25344001	1	ボルト6	BOLT M6	
23	S25475101	2	トメネジ6	SET SCREW, M6X19	
24	021060306	2	3シュナット6	NUT 3 M6	
25	S15889001	1	ヒザアゲネジリバネ	TWIST SPRING	
26	146293001	1	トメワE10	RETAINING RING, E10	
27	153230101	1	オイルニガシグチ	DRAIN	
28	S23418002	2	シメネジ4X5	SCREW, M4X5	
3	SA9943001	1	ア-スコード	EARTH CORD	
4	0A5400806	1	+ナベザクミ4X8DB	SCREW PAN (S/P WASHER) M4X8	
29	SA1969001	1	ラバ-ヒンジクミ	RUBBER HINGE ASSY	
30	143882001	2	トウブヒンジ	HEAD HINGE	
31	143910009	2	トウブヒンジウケゴム	RUBBER CUSHION	
32	SA1962001	2	トウブシキゴム	HEAD CUSHION	
33	SA1963001	2	トウブシキゴム	HEAD CUSHION	
34	109714000	4	クギ	NAIL	
37	SA2768201	1	ベルトカバー-U	BELT COVER, U	
38	SA2769101	1	ベルトカバー-D	BELT COVER, D	
39	SA2770201	1	ベルトカバー-ブラケット	BELT COVER BRACKET	
40	S37263101	1	ベルトカバー-DフタL	BELT COVER D LID, L	
41	062500816	4	ナベコ5X8	SCREW PAN M5X8	
42	062500816	2	ナベコ5X8	SCREW PAN M5X8	
43	100666002	2	マルモクネジ5.5X20	WOOD SCREW, ROUND M5.5X20	
44	025750132	2	ヒラザガネショウ5.56	WASHER PLAIN S SM5.56	
45	114486002	1	ポリオイラータイ	OILER	
47	S38300001	1	ヒザアテクミ	KNEE LIFTER ASSY	
48	146039121	1	ヒザアテツギテ	KNEE LIFTER BRACKET	
49	100463021	1	4カクボルト7.94	BOLT, SQUARE SM7.94	
50	S35820021	1	ボルト5.95X20	BOLT, SM5.95X20	
51	S38278001	1	ヒザアゲタテジク	KNEE LIFTER BAR	
52	S34756001	1	ヒザアテ	KNEE LIFTER PLATE	
53	114967021	1	ヒザアテストツパ	KNEE LIFTER PLATE STOPPER	
54	110087021	1	ボルト5.95	BOLT, SM5.95-28X8	
55	S31885021	1	ヒザアテカバー	KNEE LIFTER PLATE COVER	
5	SA4313001	1	ア-スセン	GROUND WIRE	
6	062500816	1	ナベコ5X8	SCREW PAN M5X8	
56	SA3415001	2	イトチョウシバネL	TENSION SPRING, L	

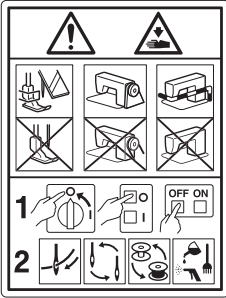

Z2. 付属品関係 / Accessories

REF.NO	CODE	Q'TY	品名	NAME OF PARTS	RM
1	S07558409	1	イトタテダイクミ3DRTHF	COTTON STAND ASSY 3DRTHF	
2	S51283001	3	ウケザラ	SPOOL STAND BASE	
3	150182000	3	スプールマット	SPOOL MAT	
4	S51282101	3	スプールクッション	SPOOL CUSHION	
5	S04109001	1	イトアンナイササエボウ	THREAD GUIDE SUPPORT BAR	
6	142997001	1	イトアンナイ3	THREAD GUIDE, 3	
12	S02747101	1	イトカケバネ	SPRING	
18	150179002	3	スプールジクB	SPOOL SHAFT B	
19	028050244	3	バネザガネ2-5	WASHER SPRING 2-5	
20	021500104	3	1シュナット5	NUT 1 M5	
21	150188009	1	スプールホルダ-ササエA	SPOOL HOLDER SUPPORT, A	
22	SA6610001	1	スプールホルダ-3	SPOOL HOLDER 3	
24	SA6610001	1	スプールホルダ-3	SPOOL HOLDER 3	
25	150183000	3	イトカケハンガ-ダイ	THREAD HANGER BASE	
26	142990001	3	スレツドブツシュ	THREAD BUSH	
27	SA6615001	1	イトアンナイホルダ-	THREAD GUIDE HOLDER	
28	138843001	1	ササエボウツギテ	JOINT	
30	062061604	2	ナベコ6X16	SCREW PAN M6X16	
31	S37037001	1	ナベコヒラザ5X32	SCREW PAN (S/P WASHER) M5X32	
33	014060632	2	アナクボミ6X6	SET SCREW SOCKET (CP) M6X6	
34	021500104	1	1シュナット5	NUT 1 M5	
35	S37037001	1	ナベコヒラザ5X32	SCREW PAN (S/P WASHER) M5X32	
36	021500104	1	1シュナット5	NUT 1 M5	
37	031452204	1	マルモク45X22	WOOD SCREW ROUND M4.5X22	
38	062501004	1	ナベコ5X10	SCREW PAN M5X10	
39	SA6609001	2	スプールホルダ-ササエ	SPOOL HOLDER SUPPORTER	

Wa. 警告ラベル / Warning labels

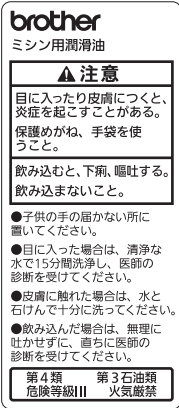
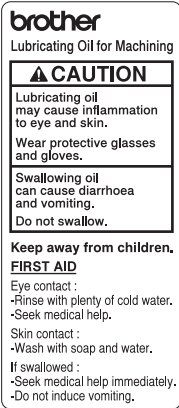
警告ラベル / Warning labels	品名 / Name of parts	Size(mm)	Code
	<p>操作注意ラベル Label caution</p>	<p>56 X 43</p>	<p>SA9826-001</p>
	<p>ワーニングマーク Injury mark</p>	<p>L=16</p>	<p>SA9957-001</p>
	<p>ワーニングマーク Injury mark</p>	<p>L=25</p>	<p>SA9957-002</p>
	<p>アースマーク Label, grounding</p>	<p>φ 12</p>	<p>S37060-001</p>
	<p>オイル警告ラベル和文 Oil warning label JP</p>	<p>68 X 30</p>	<p>SB1271-001</p>
	<p>オイル警告ラベル英文 Oil warning label EN</p>	<p>68 X 30</p>	<p>SB1270-001</p>

Ga . ゲージ部品一覧表 / Gauge parts list

標準品 / For normal

針幅 Needle gauge	針抱きセット Needle clamp set	針抱き組 Needle clamp assy	針板 Needle plate	送り歯 Feed dog	押え組 Presser foot assy
3.2mm (1/8)	(L) S15711-001 (R) S15712-001	(L) S15713-001 (R) S15714-001	117369-001	114951-001	S36562-001
4.0mm (5/32)	(L) S15717-001 (R) S15718-001	(L) S15719-001 (R) S15720-001	150850-001	116509-001	155455-001
4.8mm (3/16)	(L) S15723-001 (R) S15724-001	(L) S15725-001 (R) S15726-001	117133-001	112659-001	S36564-001
6.4mm (1/4)	(L) S15735-001 (R) S15736-001	(L) S15737-001 (R) S15738-001	117367-001	112660-001	SA4052-101
7.9mm (5/16)	(L) S15747-001 (R) S15748-001	(L) S15749-001 (R) S15750-001	144882-001	112661-001	155459-001
9.5mm (3/8)	(L) S15753-001 (R) S15754-001	(L) S15755-001 (R) S15756-001	144881-101	116510-101	155461-001
12.7mm (1/2)	(L) S15765-001 (R) S15766-001	(L) S15767-001 (R) S15768-001	S09365-001	116511-001	S09367-101
15.9mm (5/8)	(L) S15771-001 (R) S15772-001	(L) S15773-001 (R) S15774-001	159577-001	116512-001	159575-101

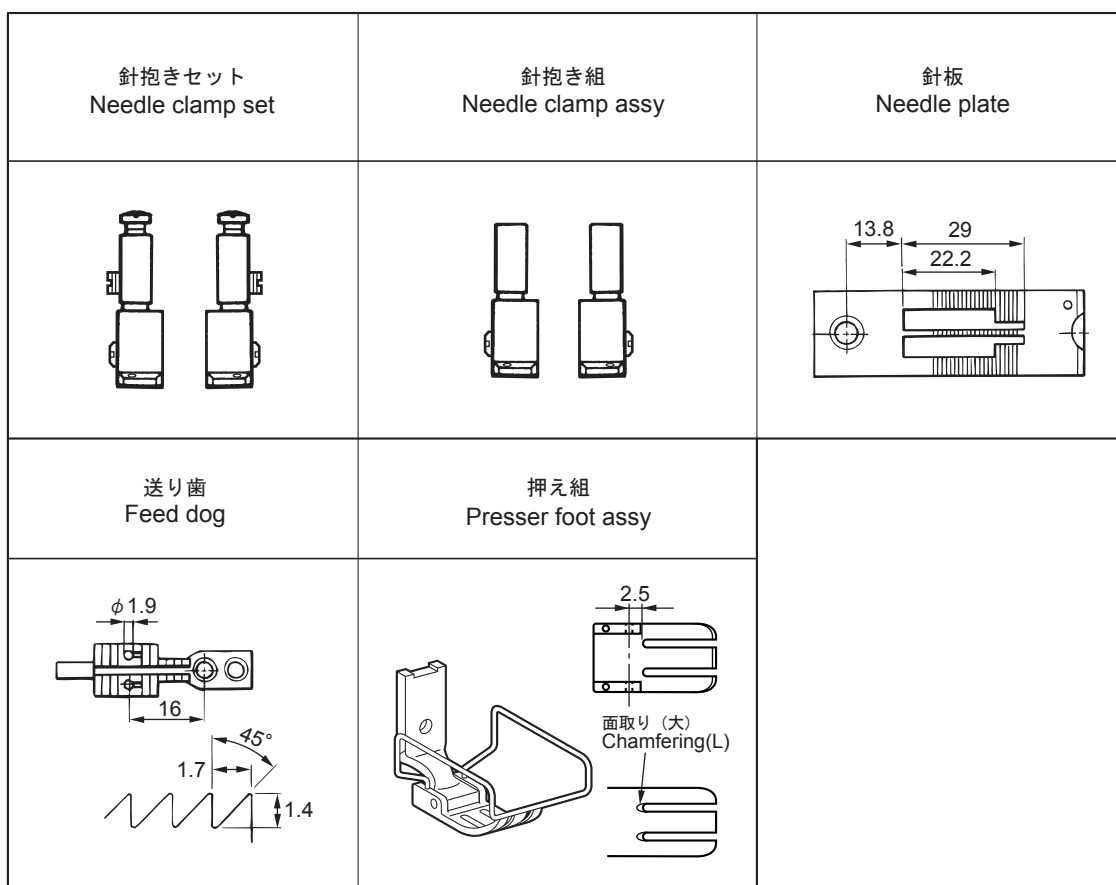

厚物用 / For heavy materials

- * 送り歯が標準品と異なります。
- * The feed dog is different from normal parts.

針幅 Needle gauge	針抱きセット Needle clamp set	針抱き組 Needle clamp assy	針板 Needle plate	送り歯 Feed dog	押え組 Presser foot assy
4.8mm (3/16)	標準品 Normal	標準品 Normal	標準品 Normal	S21149-001	標準品 Normal
6.4mm (1/4)				S21150-001	

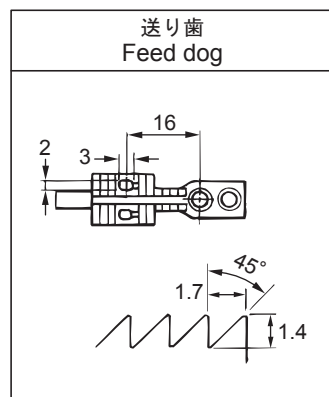

極厚物用 / For extra heavy materials

- * 送り歯が標準品と異なります。
- * The feed dog is different from normal parts.

針幅 Needle gauge	針抱きセット Needle clamp set	針抱き組 Needle clamp assy	針板 Needle plate	送り歯 Feed dog	押え組 Presser foot assy
3.2mm (1/8)	標準品 Normal	標準品 Normal	標準品 Normal	158430-001	標準品 Normal
4.8mm (3/16)				S13588-001	
6.4mm (1/4)				153882-001	
9.5mm (3/8)				153887-001	
12.7mm (1/2)				153892-001	
15.9mm (5/8)				153897-001	

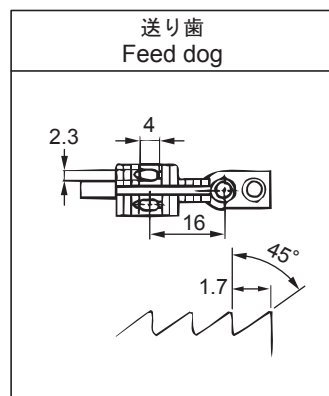

CODE	REF.NO	Page	CODE	REF.NO	Page	CODE	REF.NO	Page	CODE	REF.NO	Page
004350616	M - 19	30	062260316	C - 16	6	108549001	N - 5	32	149831101	H - 5	18
	M - 37	30	062260516	C - 20	6	108801001	L - 49	26	149863001	D - 28	10
012060636	C - 55	8	062300416	G - 23	16	108802001	G - 5	16	150179002	Z2 - 18	36
	F - 32	14	062300612	J1 - 18	20	109405001	L - 48	26	150182000	Z2 - 3	36
	G - 7	16	062300616	M - 39	30	109714000	Z1 - 34	34	150183000	Z2 - 25	36
	G - 26	16	062350512	M - 22	30	110087021	Z1 - 54	34	150188009	Z2 - 21	36
	M - 45	30	062350516	C - 37	6	112609001	C - 14	6	150820001	D - 18	10
012061036	B - 21	4		C - 42	6	112659001	Ga	38	150850001	Ga	38
	B - 25	4		D - 8	10	112660001	Ga	38	151027001	J2 - 7	22
012061832	E - 14	12	062350816	C - 32	6	112661001	Ga	38	151029001	J2 - 3	22
012400636	N - 8	32	062400616	G - 18	16	112728001	C - 33	6	151030001	J2 - 4	22
012500536	E - 22	12		G - 33	16	112753001	L - 57	26	151035001	J2 - 5	22
	M - 31	30		J1 - 26	20	113014000	B - 7	4	153230101	Z1 - 27	34
	N - 13	32		J1 - 28	20	113050001	H - 10	18	153882001	Ga	39
	N - 33	32		J1 - 31	20	114486002	Z1 - 45	34	153887001	Ga	39
012501031	J1 - 14	20		L - 54	26	114941001	M - 42	30	153892001	Ga	39
013660412	H - 3	18	062401616	L - 44	26	114951001	Ga	38	153897001	Ga	39
014060632	Z2 - 33	36	062500616	A - 9	2	114967021	Z1 - 53	34	154560101	M - 28	30
014080831	C - 43	8		L - 47	26	115947101	J1 - 41	20	154567000	C - 44	8
014400432	D - 30	10		N - 27	32	116010001	A - 18	2	154965001	J1 - 16	20
016061031	F - 29	14	062500816	A - 23	2	116509001	Ga	38	155455001	Ga	38
018062032	C - 50	8		B - 27	4	116510101	Ga	38	155459001	Ga	38
	C - 60	8		B - 32	4	116511001	Ga	38	155461001	Ga	38
	F - 15	14		D - 16	10	116512001	Ga	38	155478001	J2 - 6	22
018062532	C - 57	8		D - 25	10	117006001	B - 6	4	155479001	J2 - 2	22
018401036	C - 4	6		E - 2	12	117133001	Ga	38	155510001	M - 29	30
018401236	N - 17	32		F - 45	14	117367001	Ga	38	156557001	J1 - 53	20
021060306	E - 15	12		L - 8	26	117369001	Ga	38	158430001	Ga	39
	E - 32	12		M - 43	30	118735002	C - 51	8	159575101	Ga	38
	Z1 - 24	34		Z1 - 6	34	118954000	F - 10	14	159577001	Ga	38
021300106	M - 11	30		Z1 - 41	34	129458202	F - 22	14	159805001	M - 24	30
021350106	G - 15	16		Z1 - 42	34	138843001	Z2 - 28	36	228475000	L - 13	26
021500104	Z2 - 20	36	062501004	Z2 - 38	36	140063001	A - 1	2	S02747101	Z2 - 12	36
	Z2 - 34	36	062501016	D - 4	10	140327001	L - 63	28	S04109001	Z2 - 5	36
	Z2 - 36	36		F - 3	14	140890009	L - 56	26	S07346101	E - 6	12
021500106	E - 25	12		L - 17	26	142274101	L - 31	26	S07349001	E - 20	12
	F - 53	14	062501216	A - 7	2	142746122	F - 21	14	S07350001	E - 33	12
021500316	J1 - 11	20		E - 24	12	142990001	Z2 - 26	36	S07353001	E - 13	12
025030132	G - 22	16		F - 47	14	142997001	Z2 - 6	36	S07355051	E - 23	12
025050236	F - 48	14		F - 52	14	143611201	F - 8	14	S07374209	F - 38	14
025060132	G - 13	16	062501416	A - 5	2	143612100	F - 9	14	S07376001	F - 49	14
025060136	J1 - 48	20		D - 21	10	143613051	F - 16	14	S07419001	J1 - 5	20
	N - 15	32	071063550	D - 19	10	143616001	F - 17	14	S07420000	J1 - 4	20
025060236	L - 59	26	076023800	B - 17	4	143882001	Z1 - 30	34	S07494001	H - 12	18
025100132	F - 36	14	081004070	L - 27	26	143910009	Z1 - 31	34	S07558409	Z2 - 1	36
025710132	J1 - 10	20	081038070	L - 20	26	144226001	Z1 - 15	34	S07575000	C - 23	6
025750132	Z1 - 44	34	0A4400806	L - 36	26	144504001	M - 27	30	S07575001	C - 23	6
028050244	Z2 - 19	36	0A5400806	Z1 - 4	34	144881101	Ga	38	S07575002	C - 23	6
031452204	Z2 - 37	36	0A5501006	L - 24	26	144882001	Ga	38	S07575003	C - 23	6
047301842	D - 11	10	100032004	H - 8	18	145446001	M - 23	30	S07575004	C - 23	6
048040342	N - 2	32	100328001	F - 25	14	145446002	N - 29	32	S07575005	C - 23	6
	N - 14	32	100401022	N - 30	32	145573000	Z1 - 16	34	S07575006	C - 23	6
048060342	F - 18	14	100463021	Z1 - 49	34	146039121	Z1 - 48	34	S07575007	C - 23	6
048080342	F - 35	14	100477009	Z1 - 13	34	146293001	Z1 - 26	34	S07575008	C - 23	6
060350616	C - 27	6	100666002	Z1 - 43	34	148743001	L - 64	28	S07575009	C - 23	6
	C - 30	6	104449001	A - 4	2	149578000	Z1 - 19	34	S07575010	C - 23	6
062060816	F - 7	14	104450101	L - 19	26	149604001	C - 8	6	S07575011	C - 23	6
	F - 51	14		L - 35	26	149605001	C - 9	6	S07588101	D - 26	10
	L - 39	26		L - 51	26	149608001	C - 13	6	S09259001	J1 - 2	20
062061016	J1 - 47	20	104821001	F - 44	14	149610001	C - 17	6	S09260001	J1 - 3	20
	L - 58	26	104833001	D - 2	10	149611101	C - 18	6	S09261001	J1 - 3	20
062061604	Z2 - 30	36	107155001	C - 39	6	149622001	C - 25	6	S09279001	J2 - 8	22
062061616	C - 48	8	108549001	F - 23	14	149827001	C - 10	6	S09285051	J1 - 49	20

索引 / Index

CODE	REF.NO	Page	CODE	REF.NO	Page	CODE	REF.NO	Page	CODE	REF.NO	Page
S09285051	Z1 - 12	34	S31885021	Z1 - 55	34	SA2498001	E - 8	12	SA2626001	M - 15	30
S09365001	Ga	38	S34438001	A - 17	2	SA2499001	E - 10	12	SA2627001	M - 16	30
S09367101	Ga	38	S34561101	C - 11	6	SA2500001	E - 16	12	SA2628001	M - 17	30
S11244001	H - 7	18	S34562101	C - 12	6	SA2501001	E - 17	12	SA2629001	M - 18	30
S12441001	N - 32	32	S34756001	Z1 - 52	34	SA2502001	E - 18	12	SA2630001	M - 21	30
S13085001	H - 4	18	S35820021	Z1 - 50	34	SA2504001	E - 21	12	SA2632001	M - 30	30
S13160001	B - 15	4	S36562001	Ga	38	SA2506001	E - 26	12	SA2633001	M - 33	30
S13588001	Ga	39	S36564001	Ga	38	SA2507001	E - 27	12	SA2634001	M - 36	30
S15711001	Ga	38	S36663001	A - 16	2	SA2511001	F - 2	14	SA2635001	M - 38	30
S15712001	Ga	38	S37037001	Z2 - 31	36	SA2512001	F - 4	14	SA2636001	M - 44	30
S15713001	Ga	38		Z2 - 35	36	SA2515001	F - 5	14	SA2637001	M - 46	30
S15714001	Ga	38	S37060001	A - 21	2	SA2516001	F - 6	14	SA2638001	M - 47	30
S15717001	Ga	38		Wa	37	SA2523001	F - 26	14	SA2639001	M - 41	30
S15718001	Ga	38	S37263101	Z1 - 40	34	SA2526001	F - 30	14	SA2640001	M - 48	30
S15719001	Ga	38	S38212001	J1 - 15	20	SA2529101	F - 34	14	SA2692101	Z1 - 18	34
S15720001	Ga	38	S38266000	L - 10	26	SA2530001	F - 37	14	SA2720101	B - 22	4
S15723001	Ga	38	S38274001	M - 32	30	SA2531001	F - 39	14	SA2722001	J1 - 42	20
S15724001	Ga	38	S38278001	Z1 - 51	34	SA2532001	F - 46	14	SA2723001	L - 21	26
S15725001	Ga	38	S38300001	Z1 - 47	34	SA2533001	F - 50	14	SA2724001	G - 34	16
S15726001	Ga	38	S38428002	F - 19	14	SA2543001	G - 4	16		L - 22	26
S15735001	Ga	38	S39051001	E - 12	12	SA2544001	G - 6	16	SA2748001	B - 16	4
S15736001	Ga	38	S39830101	F - 27	14	SA2546001	G - 8	16	SA2750101	B - 19	4
S15737001	Ga	38	S48204000	C - 62	8	SA2551001	G - 25	16	SA2759101	K - 6	24
S15738001	Ga	38	S48367000	F - 41	14	SA2553001	G - 16	16	SA2768201	Z1 - 37	34
S15747001	Ga	38	S49623000	L - 14	26	SA2554001	G - 17	16	SA2769101	Z1 - 38	34
S15748001	Ga	38	S50098101	F - 24	14	SA2555001	G - 27	16	SA2770201	Z1 - 39	34
S15749001	Ga	38	S51282101	Z2 - 4	36	SA2556001	J1 - 40	20	SA2791001	F - 11	14
S15750001	Ga	38	S51283001	Z2 - 2	36		J1 - 44	20	SA2793001	F - 14	14
S15753001	Ga	38	SA1120001	B - 9	4	SA2560001	J1 - 9	20	SA2796001	F - 28	14
S15754001	Ga	38	SA1174002	E - 3	12	SA2562201	J1 - 17	20	SA2806101	G - 30	16
S15755001	Ga	38	SA1175002	E - 4	12	SA2563301	J1 - 33	20	SA2814201	L - 1	26
S15756001	Ga	38	SA1179001	E - 19	12	SA2565001	J1 - 43	20	SA2824001	M - 20	30
S15765001	Ga	38		E - 28	12	SA2566001	G - 14	16	SA2861201	B - 13	4
S15766001	Ga	38		E - 30	12	SA2567001	J1 - 45	20	SA2927001	G - 12	16
S15767001	Ga	38	SA1360101	N - 26	32	SA2568001	J1 - 46	20	SA2928001	G - 28	16
S15768001	Ga	38	SA1962001	Z1 - 32	34	SA2571101	K - 5	24	SA2929001	A - 20	2
S15771001	Ga	38	SA1963001	Z1 - 33	34	SA2572001	J1 - 19	20		L - 9	26
S15772001	Ga	38	SA1969001	Z1 - 29	34	SA2574001	J1 - 20	20		L - 18	26
S15773001	Ga	38	SA1971502	N - 1	32		J1 - 23	20	SA2956001	L - 4	26
S15774001	Ga	38	SA1981301	N - 10	32	SA2575001	J1 - 21	20	SA2957001	L - 5	26
S15889001	Z1 - 25	34	SA1982101	N - 11	32		K - 7	24	SA3040001	L - 2	26
S18964001	D - 15+	10	SA1983201	N - 12	32	SA2579001	J1 - 34	20		L - 33	26
S20681000	M - 25	30	SA1984001	N - 16	32	SA2582001	Z1 - 20	34	SA3044001	L - 40	26
S20682111	M - 26	30	SA1985001	N - 18	32	SA2584001	K - 8	24	SA3045201	L - 37	26
S21149001	Ga	39	SA1990101	N - 22	32	SA2585001	F - 12	14	SA3046001	L - 38	26
S21150001	Ga	39	SA1992101	N - 25	32		K - 10	24	SA3048101	L - 52	26
S23418002	N - 19	32	SA1994102	N - 28	32		K - 14	24	SA3049001	L - 53	26
	Z1 - 28	34	SA2165001	E - 29	12	SA2587101	K - 12	24	SA3054001	J1 - 24	20
S23460001	C - 53	8	SA2190001	N - 24	32	SA2590001	Z1 - 21	34	SA3055101	L - 7	26
S23651001	B - 10	4	SA2441101	A - 6	2	SA2604001	L - 45	26		L - 23	26
	B - 18	4	SA2444101	A - 10	2	SA2605001	L - 46	26		L - 41	26
	G - 9	16	SA2445101	A - 11	2	SA2606101	L - 50	26	SA3056001	F - 20	14
	K - 11	24	SA2448101	A - 12	2	SA2607401	M - 1	30	SA3059101	B - 31	4
S25235001	B - 11	4	SA2450101	A - 14	2	SA2613001	M - 4	30	SA3060001	L - 34	26
S25236001	B - 12	4	SA2463001	B - 24	4	SA2614201	M - 5	30	SA3062001	F - 1	14
	F - 13	14	SA2469101	B - 26	4	SA2615001	M - 6	30	SA3065001	B - 30	4
S25260001	B - 8	4	SA2485001	C - 45	8	SA2619001	M - 7	30	SA3067001	F - 40	14
	C - 46	8	SA2486101	C - 47	8	SA2620001	M - 9	30	SA3415001	Z1 - 56	34
S25289001	E - 9	12	SA2489001	C - 49	8	SA2621001	M - 10	30	SA3416101	M - 2	30
S25344001	Z1 - 22	34	SA2490101	C - 52	8	SA2623201	M - 8	30	SA3840001	G - 10	16
S25475101	Z1 - 23	34	SA2493001	C - 58	8	SA2624001	M - 13	30	SA3855001	G - 1	16
S31006002	E - 11	12	SA2494001	C - 59	8	SA2625001	M - 14	30	SA3861101	J1 - 8	20
S31032002	N - 31	32	SA2495001	E - 1	12	SA2626001	M - 12	30	SA3887001	G - 20	16

CODE	REF.NO	Page	CODE	REF.NO	Page	CODE	REF.NO	Page	CODE	REF.NO	Page
SA3888001	G - 21	16	SA4507001	M - 35	30	SA9957001	Wa	37			
SA3889101	J1 - 12	20	SA4537001	B - 28	4	SA9957002	A - 25	2			
SA3890001	K - 1	24	SA4538001	G - 29	16		Wa	37			
SA3891001	K - 3	24	SA4550001	B - 1	4	SB0771001	J2 - 1	22			
SA3894001	J1 - 30	20	SA4583001	C - 24	6	SB1270001	Z1 - 2	34			
SA3923101	L - 43	26	SA4585001	K - 2	24		Wa	37			
SA3924001	A - 2	2		K - 4	24	SB1271001	Z1 - 1	34			
SA3946001	L - 3	26	SA5154201	L - 16	26		Wa	37			
SA3965001	G - 2	16	SA5155001	C - 40	6	SB1311001	A - 3	2			
SA3990001	G - 19	16	SA5224001	L - 11	26	SB1413001	F - 33	14			
SA4009001	G - 32	16	SA5237101	C - 41	6	SB1414001	Z1 - 17	34			
SA4011001	G - 35	16	SA5293001	L - 15	26	SB1425001	C - 3	6			
SA4012001	J1 - 29	20	SA5332001	C - 61	8	SB1434001	C - 2	6			
SA4026001	J1 - 13	20	SA5333001	D - 9	10	SB1437001	C - 54	8			
SA4028001	G - 3	16	SA5336001	D - 3	10	SB1438001	C - 56	8			
SA4033101	L - 12	26	SA5588001	D - 22	10	SB1439001	E - 7	12			
SA4038001	J1 - 3	20	SA6152101	G - 11	16	SB1440001	F - 31	14			
SA4044001	J1 - 27	20	SA6166001	B - 5	4	SB1445001	G - 24	16			
SA4045001	J1 - 36	20	SA6178001	L - 6	26	SB1447001	J1 - 7	20			
SA4052101	Ga	38	SA6294101	J1 - 51	20	SB1484001	B - 4	4			
SA4149101	E - 31	12	SA6301001	J1 - 22	20		K - 9	24			
SA4212001	M - 3	30	SA6307101	J1 - 52	20	SB1485001	B - 3	4			
SA4213001	K - 15	24	SA6308001	G - 31	16	SB1536001	B - 20	4			
SA4214001	B - 23	4	SA6378001	M - 40	30		K - 13	24			
SA4313001	Z1 - 5	34	SA6414001	L - 62	28	SB1639001	N - 35	32			
SA4368001	B - 14	4	SA6415001	L - 30	26						
SA4370101	A - 8	2	SA6416001	L - 61	28						
SA4373001	B - 2	4	SA6417001	J1 - 39	20						
SA4376101	B - 29	4	SA6423001	L - 29	26						
SA4382001	C - 5	6		L - 60	26						
SA4385001	C - 6	6	SA6424101	J1 - 25	20						
SA4389101	C - 21	6	SA6425101	J1 - 35	20						
SA4391101	C - 15	6	SA6462001	J1 - 37	20						
SA4392001	C - 19	6	SA6463001	J1 - 38	20						
SA4393101	C - 34	6	SA6468001	L - 28	26						
SA4394001	C - 35	6	SA6472001	L - 42	26						
SA4395001	C - 22	6	SA6473001	L - 55	26						
SA4396001	C - 26	6	SA6474001	J1 - 6	20						
SA4397001	C - 28	6	SA6475001	L - 26	26						
SA4398001	C - 29	6	SA6592001	F - 42	14						
SA4399001	C - 31	6	SA6609001	Z2 - 39	36						
SA4400001	C - 38	6	SA6610001	Z2 - 22	36						
SA4401001	C - 36	6		Z2 - 24	36						
SA4402001	D - 1	10	SA6615001	Z2 - 27	36						
SA4404001	D - 5	10	SA7540001	L - 25	26						
SA4405001	D - 7	10	SA7548001	L - 32	26						
SA4406001	D - 10	10	SA7607101	E - 5	12						
SA4408001	D - 12	10	SA8239201	Z1 - 14	34						
SA4409001	D - 13	10	SA8503001	N - 9	32						
SA4411101	D - 14	10	SA8507001	N - 7	32						
SA4412001	D - 17	10	SA8508001	N - 3	32						
SA4413001	D - 20	10	SA8509001	N - 23	32						
SA4414001	D - 23	10	SA8510101	N - 20	32						
SA4415001	D - 24	10	SA8511101	N - 4	32						
SA4416001	D - 27	10	SA8512101	N - 21	32						
SA4417001	D - 29	10	SA8738101	C - 1	6						
SA4418001	D - 31	10	SA8749001	C - 7	6						
SA4419001	D - 15+	10	SA8982202	N - 34	32						
SA4437401	J1 - 1	20	SA9563001	N - 6	32						
SA4438401	J1 - 32	20	SA9826001	A - 22	2						
SA4441001	D - 6	10		Wa	37						
SA4444001	J1 - 3	20	SA9943001	Z1 - 3	34						
SA4506001	M - 34	30	SA9957001	A - 24	2						

brother®

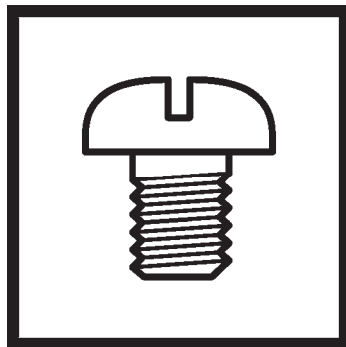

パーツブック
PARTS BOOK

ブラザー工業株式会社 <http://www.brother.co.jp/>
〒448-0803 刈谷市野田町北地藏山1番地5 TEL:0120-33-2392
BROTHER INDUSTRIES, LTD. <http://www.brother.com/>
1-5, Kitajizoyama, Noda-cho, Kariya 448-0803, Japan. Phone : 81-566-95-0088

©2010 Brother Industries, Ltd. All Rights Reserved.

T-8750C
SB1466-001.J/E
2010.05.B (1)