

SN-7210/7220

パーツブック
PARTS BOOK

SN-7230/7240

Spare parts department

本縫針送りミシン

本縫針送り自動糸切りミシン

SINGLE NEEDLE NEEDLE FEED LOCK STITCHER

SINGLE NEEDLE NEEDLE FEED LOCK STITCHER WITH THREAD TRIMMER

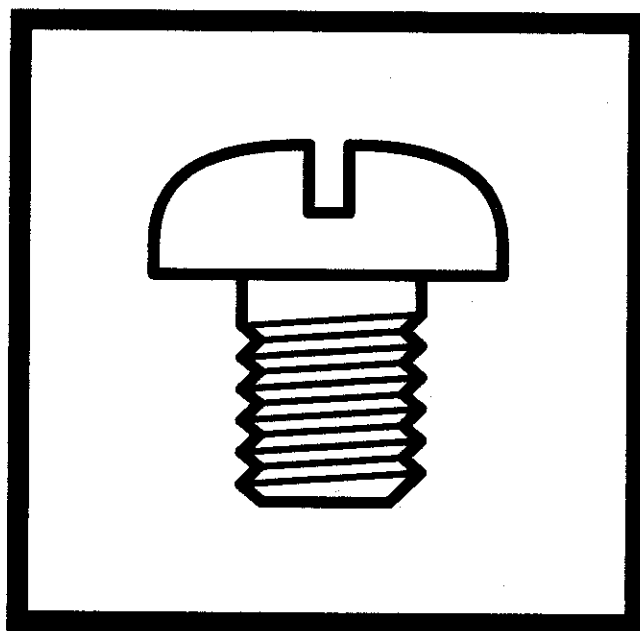

brother[®]

BROTHER INDUSTRIES, LTD.

SN-72^[(1)]0^[(2)]

(1)

- 1 --- 本縫針送りミシン/ SINGLE NEEDLE NEEDLE FEED LOCK STITCHER
- 3 --- 本縫針送り大釜ミシン
/ SINGLE NEEDLE NEEDLE FEED LOCK STITCHER WITH LARGE HOOK

(2) 用途/ Application

表記/ Indication

- 3 --- 中厚物/ Medium materials (-3)
- 5 --- 厚物/ Heavy materials (-5)

BROTHER INDUSTRIES, LTD.

SN-72^[(1)]0^[(2)]0^[(3)]

(1)

- 2 --- 本縫針送り自動糸切りミシン
/ SINGLE NEEDLE NEEDLE FEED LOCK STITCHER WITH THREAD TRIMMER
- 4 --- 本縫針送り大釜糸切りミシン
/ SINGLE NEEDLE NEEDLE FEED LOCK STITCHER WITH LARGE HOOK
AND THREAD TRIMMER

(2) 付加機能 1/ Additional function 1

表記/ Indication

- 1 --- 糸切り/ Thread trimmer (-10□)
- 3 --- 糸切り + クイックバック/ Thread trimmer + Quick back device (-30□)
- 4 --- 糸切り + クイックバック + 糸払い
/ Thread trimmer + Quick back device + Thread wiper (-40□)
- 9 --- 糸切り + クイックバック + 糸払い + 電磁式押え上げ装置
/ Thread trimmer + Quick back device + Thread wiper + Solenoid type presser foot lifter (-90□)

(3) 用途/ Application

表記/ Indication

- 3 --- 中厚物/ Medium materials (-□03)
- 5 --- 厚物/ Heavy materials (-□05)

パーツブックご利用に際して

1. この本は、1999年6月のデータに基づいて作成されたものです。
2. 部品は予告なしに設計変更される場合があります。
3. 組単位で補給する部品は、 破線で示しております。

目 次

<p>A. 主体関係 1</p> <p>B. 上軸・天秤関係 3</p> <p>C. 針送り関係 7</p> <p>D. 押工関係 9</p> <p>E. 送り関係 11</p> <p>F. 膝上げ関係 19</p> <p>G. 逆転関係 (7220, 7240: -30□, -40□, -90□) 19</p> <p>H. カマ関係 21</p> <p>J1. 給油潤滑関係 25</p> <p>J2. 給油潤滑関係 29</p> <p>K. 糸通シ関係 31</p> <p>L1. 糸切り関係 (7220) 35</p> <p>L2. 糸切り関係 (7240) 39</p> <p>M. 押工上げ関係 (7220, 7240: -90□) 43</p> <p>N. 糸緩メ関係 (7220, 7240) 43</p> <p>P. 糸払イ関係 (7220, 7240: -40□, -90□) 45</p> <p>Q. 針位置検出器関係 (7220, 7240) 47</p> <p>R. コントロールボックス関係 (7220, 7240) 47</p>	<p>S. ヒザスイッチ関係 (7220, 7240: -90□) 49</p> <p>T. 逆転スイッチ関係 (7220, 7240) 49</p> <p>U. 踏板関係 (オプション部品) 51</p> <p>V1. 電磁押工上げ関係 (7220, 7240 輸出用) 51</p> <p>V2. 電磁押工上げ関係 (7220, 7240: オプション部品) 53</p> <p>W. 糸払イセット関係 (7220, 7240: オプション部品) 55</p> <p>Z. 付属品関係 57</p> <p>Ga1. ゲージ部品一覧表 (7210, 7220) 61</p> <p>Ga2. ゲージ部品一覧表 (7210, 7220) 62</p> <p>Ga3. ゲージ部品一覧表 (7210, 7220) 63</p> <p>Ga4. ゲージ部品一覧表 (7230, 7240) 64</p> <p>Wa. 警告ラベル 65</p> <p style="text-align: center;">索引 66</p>
---	--

Notes for using this parts book

1. This book was prepared based on information available in June 1999.
2. Parts are subject to changes in design without prior notice.
3. Parts supplied as complete assemblies are circled by a dotted line [] .

CONTENTS

A . Machine body	1	Q . Synchronizer (7220, 7240)	47
B . Upper shaft and thread take-up mechanism	3	R . Control box mechanism (7220, 7240) ...	47
C . Needle feed mechanism	7	S . Knee switch mechanism (7220, 7240: -90□)	49
D . Presser foot mechanism	9	T . Quick reverse switch mechanism (7220, 7240)	49
E . Feed mechanism	11	U . Foot switch pedal mechanism (Option parts)	51
F . Knee lifter mechanism	19	V1 . Presser foot lifting solenoid set (7220, 7240: -90□)	51
G . Quick reverse mechanism (7220, 7240: -30□, -40□, -90□)	19	V2 . Presser foot lifting solenoid set (7220, 7240: Option parts)	53
H . Rotary hook mechanism	21	W . Thread wiper set (7220, 7240: Option parts)	55
J1 . Lubrication	25	Z . Accessories	57
J2 . Lubrication	29	Ga1 . Gauge parts List (7210, 7220)	61
K . Threading mechanism	31	Ga2 . Gauge parts List (7210, 7220)	62
L1 . Thread trimmer mechanism (7220)	35	Ga3 . Gauge parts List (7210, 7220)	63
L2 . Thread trimmer mechanism (7240)	39	Ga4 . Gauge parts List (7230, 7240)	64
M . Presser foot lifter mechanism (7220, 7240)	43	Wa . Warning labels	65
N . Tension release mechanism (7220, 7240)	43	Index	66
P . Thread wiper mechanism (7220, 7240: -40□, -90□)	45		

Hinweise zur Verwendung dieser Teileliste

1. Dieses Buch basiert auf den Informationen vom Juni 1999.
2. Modelländerungen sind vorbehalten.
3. Die Teile, die als kompletter Satz geliefert werden, sind mit einer gestrichelten Linie umrandet.

INHALTSVERZEICHNIS

A . Maschinengehäuse	1	Q . Synchronisator (7220, 7240)	47
B . Obere Welle und Fadenabnahmevorrichtung	3	R . Schaltkasten (7220, 7240)	47
C . Nadelstange transportvorrichtung	7	S . Knieschalter (7220, 7240: -90□)	49
D . Stoffdrückerfuß	9	T . Umkehrschalter (7220, 7240)	49
E . Transportvorrichtung	11	U . Fußbetätigung (Sonderzubehör)	51
F . Kniehebel	19	V1 . Solenoidsatz für die anhebung des stoffdrückerfußes (7220, 7240: -90□)	51
G . Umkehr (7220, 7240: -30□, -40□, -90□)	19	V2 . Solenoidsatz für die anhebung des stoffdrückerfußes (7220, 7240: Sonderzubehör)	53
H . Greifervorrichtung	21	W . Fadenspannvorrichtung (7220, 7240: Sonderzubehör)	55
J1 . Schmierung	25	Z . Zubehör	57
J2 . Schmierung	29	Ga1 . Lehrenliste (7210, 7220)	61
K . Fadenführungsvorrichtung	31	Ga2 . Lehrenliste (7210, 7220)	62
L1 . Fadenabschneidevorrichtung (7220) ...	35	Ga3 . Lehrenliste (7210, 7220)	63
L2 . Fadenabschneidevorrichtung (7240) ...	39	Ga4 . Lehrenliste (7230, 7240)	64
M . Stoffhalterhebevorrichtung (7220, 7240)	43	Wa . Warnschilder	65
N . Spannungsverminderungsvorrichtung (7220, 7240)	43	Verzeichnis	66
P . Fadenwischvorrichtung (7220, 7240: -40□, -90□)	45		

< 7210, 7230 >

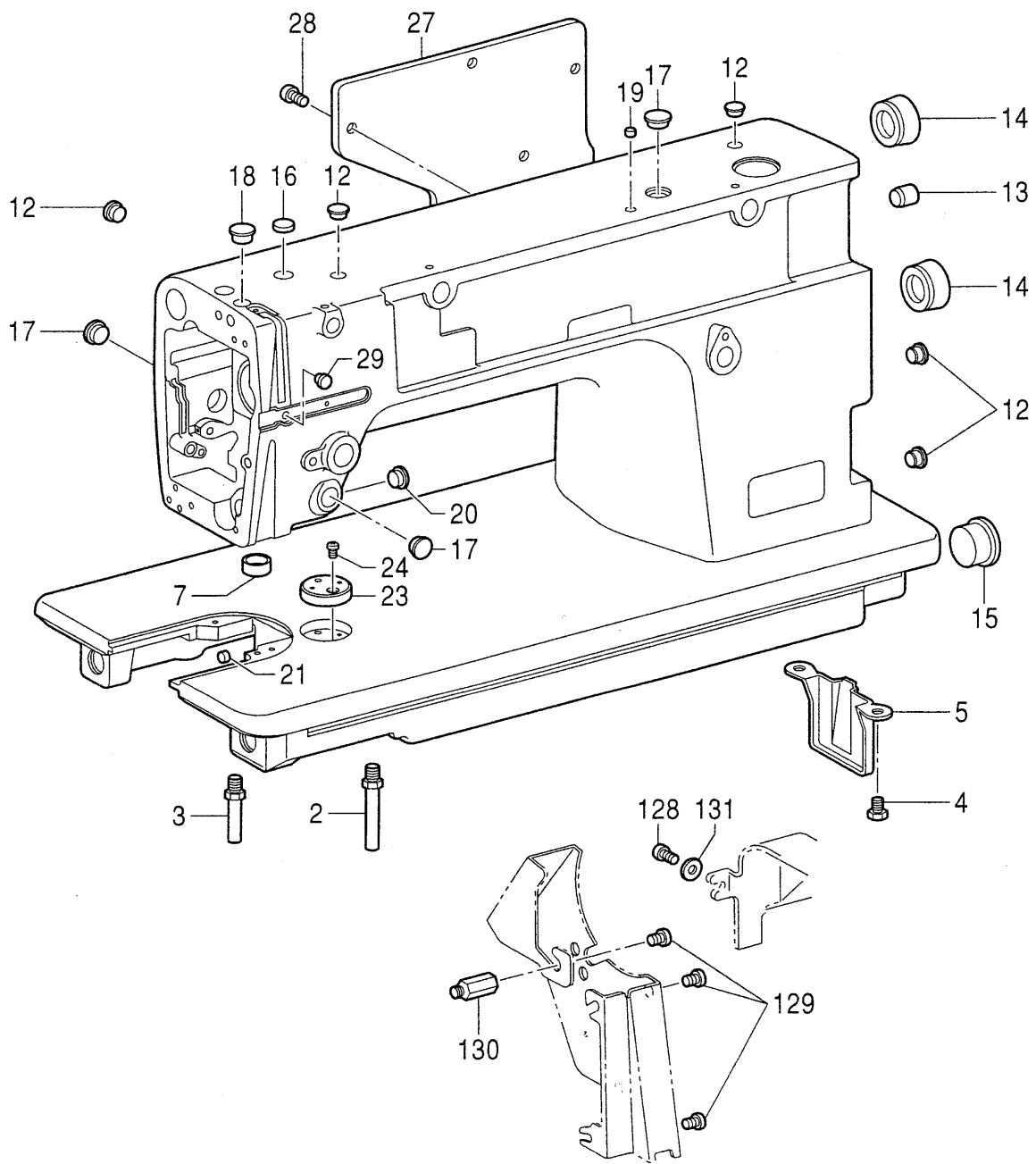
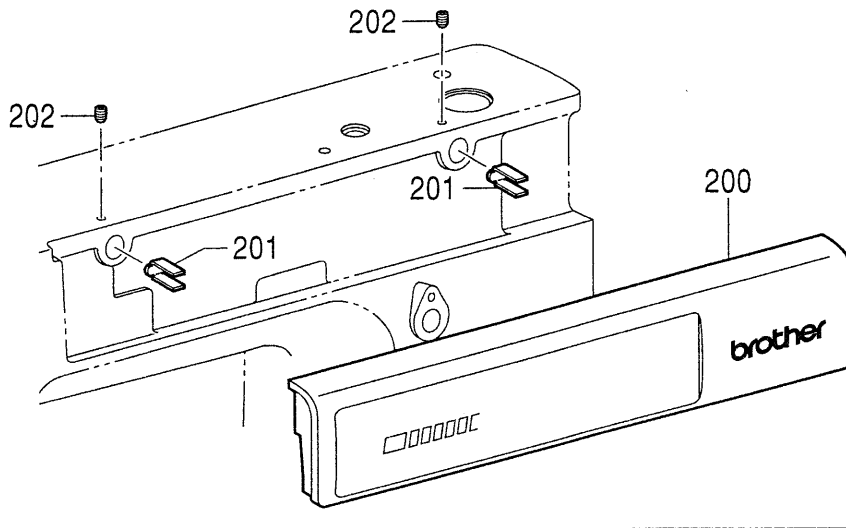

A. 主体関係 / Machine body

REF.NO.	CODE	Q'TY	ヒンメイ	NAME OF PARTS	RM
2	104829101	1	キヤクチュウL	BED LEG, L	
3	104830101	1	キヤクチュウS	BED LEG, S	
4	140704001	2	ボルト7.14	BOLT, SM7.14	
5	118672001	1	ポンプカバー	PUMP COVER	
7	S01416000	1	オイルヨケリング	RING, OIL STOPPER	
12	104450109	5	ゴムセン8	RUBBER CAP, 8	
13	104832009	1	ゴムセン10.7	RUBBER CAP, 10.7	
14	104451109	2	ゴムセン23.9	RUBBER CAP, 23.9	
15	108520009	1	ゴムセン19.8	RUBBER CAP, 19.8	
16	104821009	1	ゴムセン10.5	RUBBER CAP, 10.5	
17	104449009	3	ゴムセン15.5	RUBBER CAP, 15.5	
18	S12717009	1	ゴムセン11.5	RUBBER CAP, 11.5	
19	156217009	1	ゴムセン8.5	RUBBER CAP, 8.5	
20	117936009	1	ゴムセン9.4	RUBBER CAP, 9.4	
21	142274009	1	ゴムセン4.2	RUBBER CAP, 4.2	
23	S09621151	1	ジヨウギイタ	RULER PLATE	
24	062670612	1	ナベコ357-40X6	SCREW, PAN SM3.57-40X6	
27	S02499009	1	ガワイタ	REAR COVER	
28	062681012	7	ナベコ437-40X10	SCREW, PAN SM4.37-40X10	
29	111865009	1	<7230, 7240 用> セン6	<For 7230, 7240> CAP, 6	
128	062680812	1	ナベコ437-40X8	SCREW, PAN SM4.37-40X8	
129	062760812	3	ナベコ595-28X8	SCREW, PAN SM5.95-28X8	
130	157969001	1	スタッド	STUD	
131	100645003	1	ザガネ	WASHER	
200	S45877001	1	<7210, 7230 用> BF-0パネルクミST	<For 7210, 7230> B-PANEL ASSY, F-0 ST	
201	S34448001	2	パネルシジダイ	PANEL SUPPORT BRACKET	
202	014680622	2	アナトメネジ4.37クボミ	SET SCREW, SOCKET (CP) SM4.37	

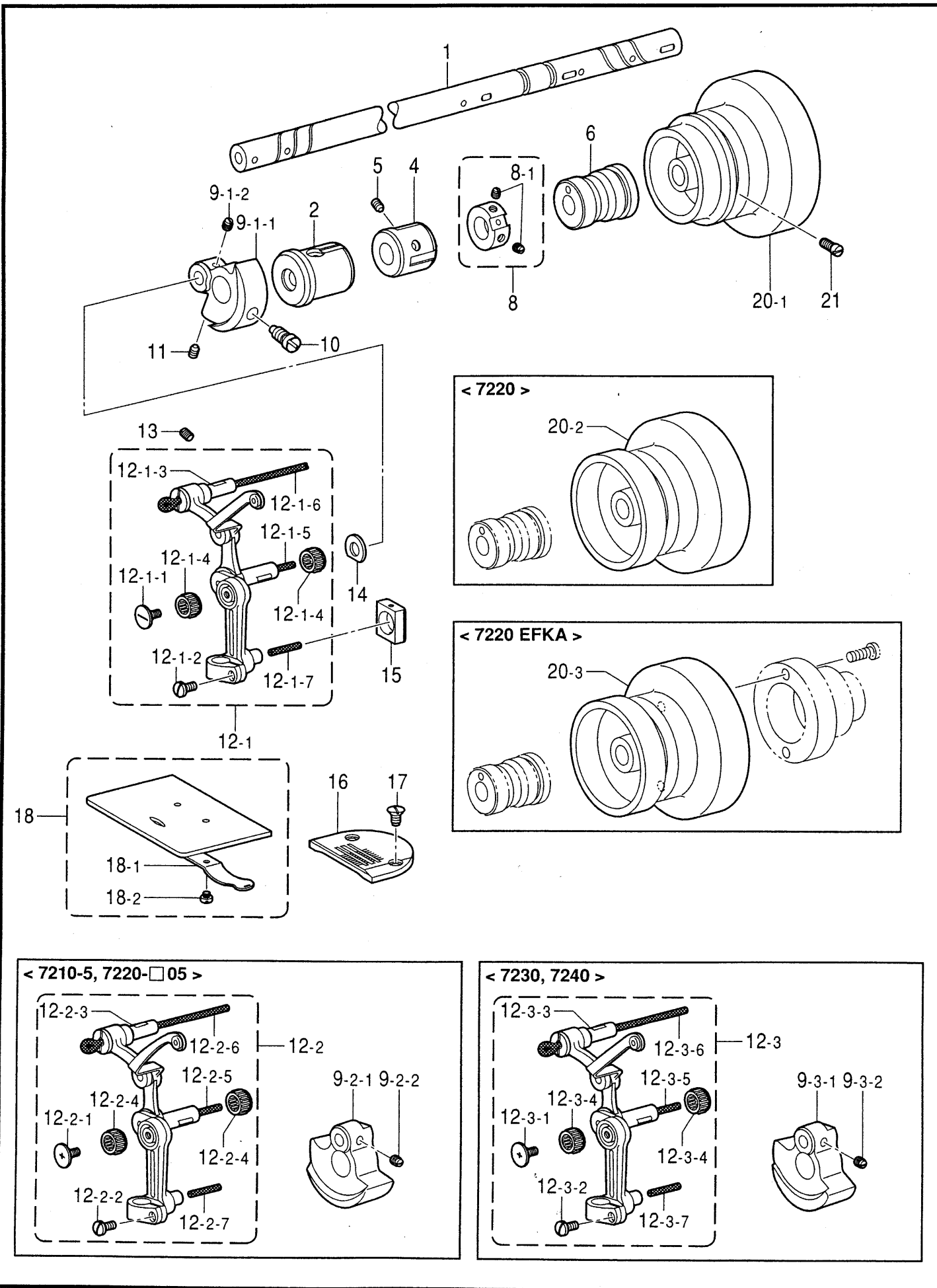

B. 上軸・天秤関係 / Upper shaft and thread take-up mechanism

REF.NO.	CODE	Q'TY	ヒンメイ	NAME OF PARTS	RM
1	S45806001	1	ウワジク	UPPER SHAFT	
2	S02805001	1	ウワジクメタルL	UPPER SHAFT BUSH, L	
4	140726000	1	ウワジクメタルM	UPPER SHAFT BUSH, M	
5	013760610	1	トメネジ5.95クボミ	SET SCREW, (CP) SM5.95	
6	146331001	1	<7210, 7230 用> ウワジクメタルR	<For 7210, 7230> UPPER SHAFT BUSH, R	
6	S02524001	1	<7220, 7240 用> ウワジクメタルR	<For 7220, 7240> UPPER SHAFT BUSH, R	
8	181916101	1	セットカラークミ	SET SCREW COLLAR ASSY	
8-1	100251001	2	トメネジ6.35	SET SCREW, SM6.35	
9-1	S45808001	1	<7210-3, 7220-□03 用> テンピンクランククミ	<For 7210-3, 7220-□03> THREAD TAKE-UP CRANK ASSY	
9-1-1	S45809000	1	テンピンクランク	THREAD TAKE-UP CRANK	
9-1-2	100251001	2	トメネジ6.35	SET SCREW, SM6.35	
9-2	S45810001	1	<7210-5, 7220-□05 用> テンピンクランククミ	<For 7210-5, 7220-□05> THREAD TAKE-UP CRANK ASSY	
9-2-1	S45811000	1	テンピンクランク	THREAD TAKE-UP CRANK	
9-2-2	100251001	2	トメネジ6.35	SET SCREW, SM6.35	
9-3	S45887001	1	<7230, 7240 用> テンピンクランククミ	<For 7230, 7240> THREAD TAKE-UP CRANK ASSY	
9-3-1	S45888000	1	テンピンクランク	THREAD TAKE-UP CRANK	
9-3-2	100251001	2	トメネジ6.35	SET SCREW, SM6.35	
10	104464001	1	シメネジ7.14	SCREW, SM7.14	
11	014771022	1	アナトメネジ6.35クボミ	SET SCREW, SOCKET (CP) SM6.35	
12-1	S34295001	1	<7210-3, 7220-□03 用> ハリボウレンカンクミ	<For 7210-3, 7220-□03> THREAD TAKE-UP LEVER SET	
12-1-1	145465001	1	シメネジ3.57L	SCREW, SM3.57 L	
12-1-2	140004001	1	シメネジ3.57	SCREW, SM3.57	
12-1-3	111468001	1	テンピンササエジク	THREAD TAKE-UP SUPPORT SHAFT	
12-1-4	147777000	2	ニードルベアリング	NEEDLE BEARING	
12-1-5	145624000	1	フェルト	FELT	
12-1-6	155488000	1	クミヒモ	WICK, L = 90	
12-1-7	158727001	1	クミヒモ4X4	WICK, 4X4 L = 27	
12-2	S45815001	1	<7210-5, 7220-□05 用> ハリボウレンカンクミ	<For 7210-5, 7220-□05> THREAD TAKE-UP LEVER SET	
12-2-1	145465001	1	シメネジ3.57L	SCREW, SM3.57 L	
12-2-2	140004001	1	シメネジ3.57	SCREW, SM3.57	
12-2-3	111468001	1	テンピンササエジク	THREAD TAKE-UP SUPPORT SHAFT	
12-2-4	116735000	2	ニードルベアリング	NEEDLE BEARING	
12-2-5	145624000	1	フェルト	FELT	
12-2-6	155488000	1	クミヒモ	WICK, L = 90	
12-2-7	158727001	1	クミヒモ4X4	WICK, 4X4 L = 27	
12-3	S45897001	1	<7230, 7240 用> ハリボウレンカンクミ	<For 7230, 7240> THREAD TAKE-UP LEVER SET	
12-3-1	145465001	1	シメネジ3.57L	SCREW, SM3.57 L	
12-3-2	140004001	1	シメネジ3.57	SCREW, SM3.57	
12-3-3	111468001	1	テンピンササエジク	THREAD TAKE-UP SUPPORT SHAFT	
12-3-4	116735000	2	ニードルベアリング	NEEDLE BEARING	
12-3-5	145624000	1	フェルト	FELT	

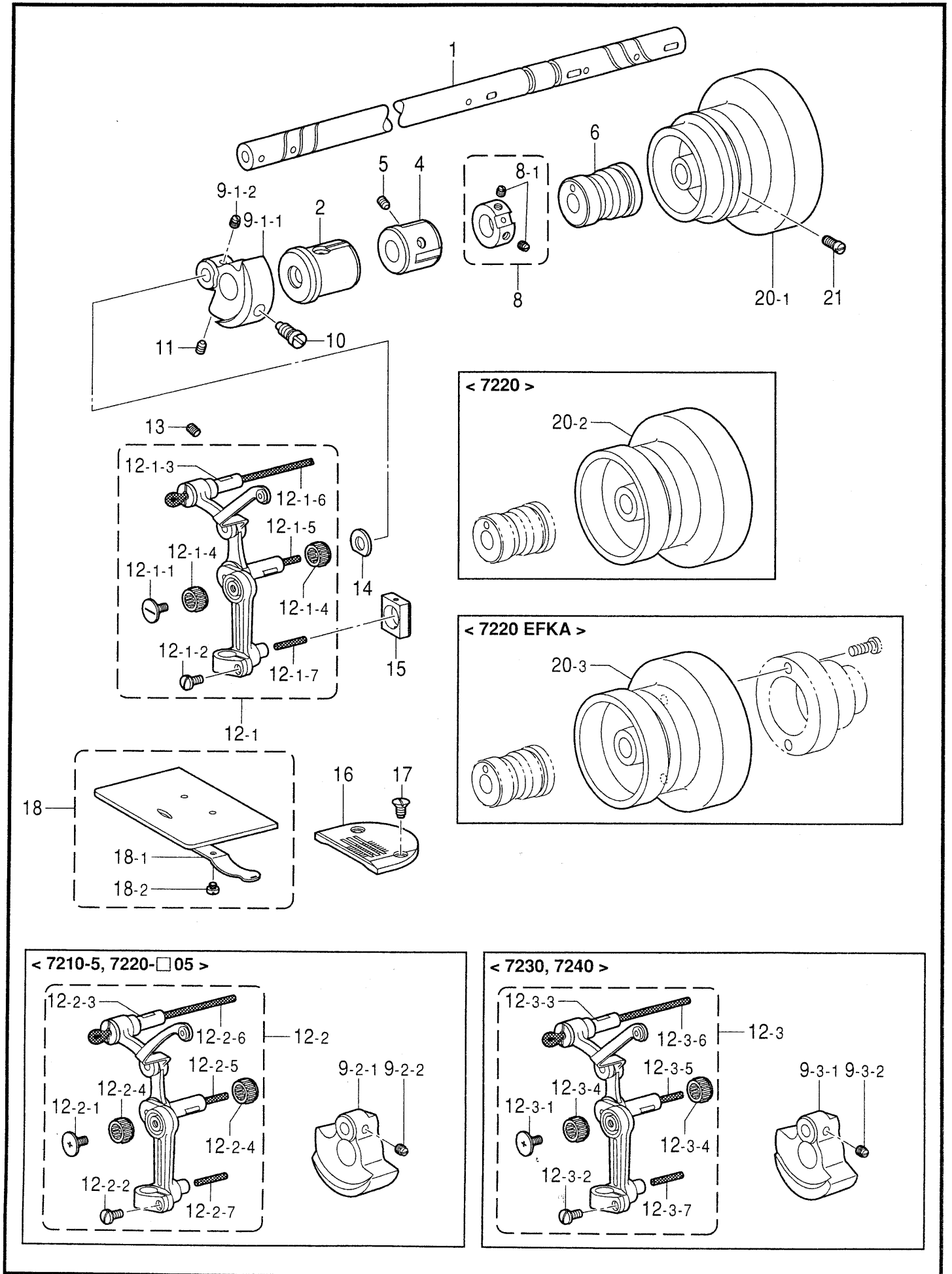

B. 上軸・天秤関係 / Upper shaft and thread take-up mechanism

REF.NO.	CODE	Q'TY	ヒンメイ	NAME OF PARTS	RM
12-3-6	118768001	1	クミヒモ	WICK, L = 150	
12-3-7	158727001	1	クミヒモ4X4	WICK, 4X4 L = 27	
13	013781012	1	トメネジ6.35	SET SCREW, (CP) SM6.35	
14	110367001	1	ザガネ	WASHER, PLAIN SPECIAL 8	
15	102630001	1	ハリボウアンナイカクコマ	SLIDE BLOCK, N-BAR GUIDE	
16	143855001	1	<7210-3, 7220-□03 用> ハリイタ <記号143855>	<For 7210-3, 7220-□03> NEEDLE PLATE <Marked in 143855>	
16	143857001	1	ハリイタ <記号143857>	NEEDLE PLATE <Marked in 143857>	
16	148842001	1	<7210-5, 7220-□05 用> ハリイタ	<For 7210-5, 7220-□05> NEEDLE PLATE	
16	S13101001	1	<7210-5, 7220-□05 用> <7230, 7240 用> ハリイタ	<For 7210-5, 7220-□05> <For 7230, 7240> NEEDLE PLATE	
17	100032004	2	サラネジ4.37	SCREW, FLAT SM4.37	
18	180018151	1	スベリイタクミ	SLIDE PLATE ASSY	
18-1	114561001	1	スベリイタウラバネ	SPRING	
18-2	122771051	2	シメネジ2.38	SCREW, SM2.38	
20-1	145471109	1	<7210, 7230 用> プーリ	<For 7210, 7230> PULLEY	
20-2	S02538109	1	<7220, 7240 用> プーリ <内蔵式>	<For 7220, 7240> PULLEY <Buit-in type>	
20-3	S02539109	1	<7220 エフカ用> -----	<For EFKA of 7220> PULLEY	
21	S33689002	2	アタマトメクボミ595-14	SET SCREW, (CP) SM5.95-14	
16	118681001	1	" オプション部品 " ハリイタ <記号118681>	" OPTIONPARTS " NEEDLE PLATE <Marked in 118681>	
16	140715001	1	ハリイタ <記号140715>	NEEDLE PLATE <Marked in 140715>	
16	141156001	1	ハリイタ <記号141156>	NEEDLE PLATE <Marked in 141156>	
16	147954001	1	ハリイタ <記号147954>	NEEDLE PLATE <Marked in 147954>	
16	148300001	1	ハリイタ <記号148300>	NEEDLE PLATE <Marked in 148300>	
16	S01988001	1	ハリイタ <記号S01988>	NEEDLE PLATE <Marked in S01988>	

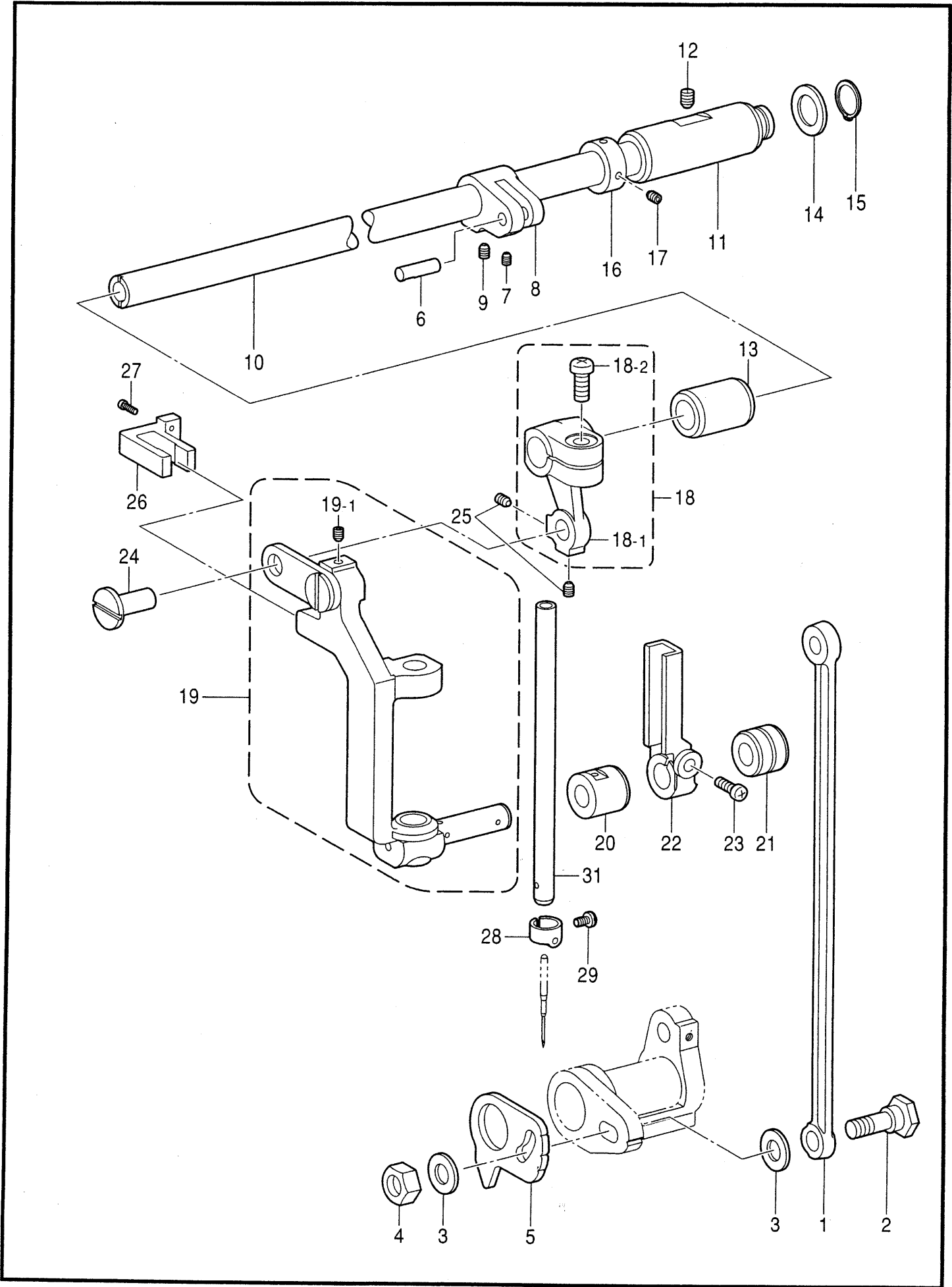

C. 針送り関係 / Needle feed mechanism

REF.NO.	CODE	Q'TY	ヒンメイ	NAME OF PARTS	RM
1	S16299001	1	ハリオクリレンカン	NEEDLE FEED CONNECTING ROD	
2	S45816001	1	ダンネジ6.35	SHOULDER SCREW, SM6.35	
3	159486001	2	ザガネ	WASHER	
4	110744002	1	ナツト6.35	NUT, SM6.35	
5	S45817101	1	アジャスタ	ADJUSTER	
6	156264001	1	ジク6,35X19,5	STUD, 6.35X19.5	
7	014680622	1	アナトメネジ4.37クボミ	SET SCREW, SOCKET (CP) SM4.37	
8	159487000	1	ハリオクリジクウデ	NEEDLE FEED SHAFT ARM	
9	014780622	2	アナトメネジ6.35クボミ	SET SCREW, SOCKET (CP) SM6.35	
10	S45818101	1	ハリオクリジク	NEEDLE FEED SHAFT	
11	159489101	1	ハリオクリジクメタルR	BUSH, R N-FEED SHAFT	
12	013760610	1	トメネジ5.95クボミ	SET SCREW, (CP) SM5.95	
13	159490001	1	ハリオクリジクメタルL	BUSH, L N-FEED SHAFT	
14	120023001	1	カラー	COLLAR	
15	048120142	1	トメワジクヨウC12	RETAINING RING, EXTERNAL C12	
16	140092001	1	セットカラー	SET SCREW COLLAR	
17	014680422	2	アナトメネジ4.37クボミ	SET SCREW, SOCKET (CP) SM4.37	
18	S45819001	1	ハリオクリウデクミ	NEEDLE FEED ARM ASSY	
18-1	S45820001	1	ハリオクリウデ	NEEDLE FEED ARM	
18-2	062061616	1	ナベコ6X16	SCREW, PAN M6X16	
19	S45823101	1	ハリボウダイクミ	NEEDLE BAR BRACKET ASSY	
19-1	014680422	1	アナトメネジ4.37クボミ	SET SCREW, SOCKET (CP) SM4.37	
20	S45833001	1	ハリボウダイメタルL	NEEDLE BAR BRACKET BUSH, L	
21	S45834001	1	ハリボウダイメタルR	NEEDLE BAR BRACKET BUSH, R	
22	S45835000	1	カクコマアンナイ	SLIDE BLOCK GUIDE	
23	062501616	1	ナベコ5X16	SCREW, PAN M5X16	
24	151308101	1	レンカンジク12.5	CONNECTING STUD, 12.5	
25	014500536	2	アナクボミ5X5	SET SCREW, SOCKET (CP) M5X5	
26	S45836000	1	ハリボウダイアンナイ	NEEDLE BAR BRACKET GUIDE	
27	062672012	2	ナベコ357-40X20	SCREW, PAN SM3.57-40X20	
28	151594001	1	ハリボウイトアンナイ	THREAD GUIDE, NEEDLE BAR	
29	140553102	1	アタマツキトメネジ3.18	SET SCREW, SM3.18	
<hr/>					
31	S45828001	1	<7210 用> <DB針 -3用> ハリボウ	<For 7210> <For using the DB needle "-3"> NEEDLE BAR	
31	S45821001	1	<DP針 -3用> ハリボウ	<For using the DP needle "-3"> NEEDLE BAR	
31	S45829001	1	<-5 用> ハリボウ	<For "-5"> NEEDLE BAR	
<hr/>					
31	S45830001	1	<7220 用> <DB針 -□03 用> ハリボウ	<For 7220> <For using the DB needle "-□03"> NEEDLE BAR	
31	S45822001	1	<DB針 -□03 用> ハリボウ	<For using the DB needle "-□03"> NEEDLE BAR	
31	S45831001	1	<-□05 用> ハリボウ	<For "-□05"> NEEDLE BAR	
<hr/>					
31	S45889001	1	<7230 用> ハリボウ	<For 7230> NEEDLE BAR	
<hr/>					
31	S45890001	1	<7240 用> ハリボウ	<For 7240> NEEDLE BAR	

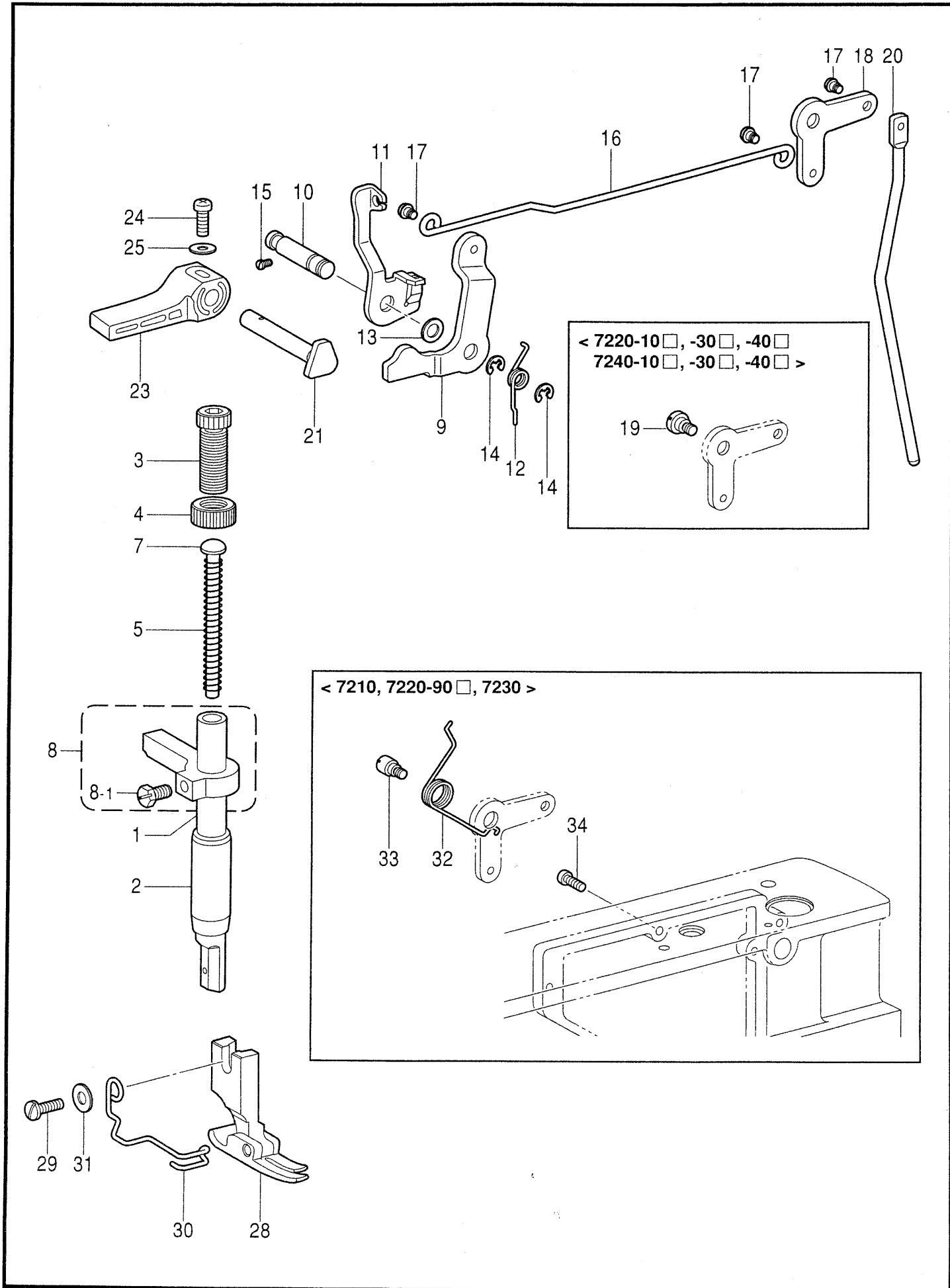

D. 押工関係 / Presser foot mechanism

REF.NO.	CODE	Q'TY	ヒンメイ	NAME OF PARTS	RM
1	111466101	1	オサエボウ	PRESSER BAR	
2	145472001	1	オサエボウメタル	BUSH, PRESSER BAR	
3	S31012001	1	オサエチヨウセツネジ	ADJUSTING SCREW, PRESSER	
4	S31013001	1	チヨウセツネジツマミナツト	ADJUSTING NUT, PRESSER	
5	141728001	1	オサエバネ	PRESSER SPRING	
7	141208001	1	オサエバネアンナイ	SPRING GUIDE	
8	181919101	1	オサエボウダキネジツキ	P-BAR GUIDE BRACKET W/SCR.	
8-1	142403001	1	ボルト5.95	BOLT, (CP) SM5.95-28X10	
9	145580001	1	オサエアゲレバー	PRESSER BAR LIFTER LEVER	
10	S46734001	1	オサエアゲレバーク	SHAFT, P-BAR LIFTER LEVER	
12	S46736001	1	オサエアゲレバーバネ	SPRING	
13	109763002	1	ザガネ	WASHER	
14	048040342	2	トメワE4	RETAINING RING, E4	
15	S01998001	1	アタマツキトメネジ3.57	SET SCREW, SM3.57	
16	S45908001	1	ヒザアゲレンカン	KNEE LIFTER CONNECTING ROD	
17	145478101	3	ダンネジ4.76	SHOULDER SCREW, SOCKET SM4.76	
18	145479002	1	ヒザアゲレバー	LEVER, KNEE LIFTER	
19	145480101	1	<7220-10□,-30□,-40□用> <7240-10□,-30□,-40□用> ダンネジ6.35	<For 7220-10□, -30□, -40□> <For 7240-10□, -30□, -40□> SHOULDER SCREW, SM6.35	
20	S02548001	1	ヒザアゲボウ	KNEE LIFTER BAR	
21	S45837001	1	オサエアゲクランク	PRESSER BAR LIFTER CRANK	
23	S31006001	1	オサエアゲテコ	PRESSER BAR LIFTER	
24	062351216	1	ナベコ35X12	SCREW, PAN M3.5X12	
25	102707001	1	ザガネ	WASHER	
28	141158101	1	<7210-3用> オサエクミ <記号141158>	<For 7210-3> PRESSER FOOT ASSY <Marked in 141158>	
28	S36909001	1	<7210-3, 7220-□03用> オサエクミ <記号S36909>	<For 7210-3, 7220-□03> PRESSER FOOT ASSY, W/F-G <Marked in S36909>	
28	147703101	1	<7220-□03用> オサエクミ <記号147703>	<For 7220-□03> PRESSER FOOT ASSY <Marked in 147703>	
28	S36911001	1	<7210-5, 7220-□05用> オサエクミ <記号S36911>	<For 7210-5, 7220-□05> PRESSER FOOT ASSY, W/F-G <Marked in S36911>	
28	140717101	1	<7210-5用> オサエクミ <記号140717>	<For 7210-5> PRESSER FOOT ASSY <Marked in 140717>	
28	S36910001	1	<7220-□05用> オサエクミ <記号S36910>	<For 7220-□05> PRESSER FOOT ASSY, W/F-G <Marked in S36910>	
28	S36909001	1	<7230, 7240用> オサエクミ <記号S36909>	<For 7230, 7240> PRESSER FOOT ASSY, W/F-G <Marked in S36909>	
28	S45919001	1	オサエクミ <記号S45919>	PRESSER FOOT ASSY <Marked in S45919>	
28	S45920001	1	オサエクミ <記号S45920>	PRESSER FOOT ASSY, W/F-G <Marked in S45920>	
29	S13385001	1	シメネジ3.57X10	SCREW, SM3.57X10	
30	150384101	1	フィンガーガード	FINGER GUARD	
31	025350132	1	ヒラザガネシヨウ	WASHER, PLAIN S 3.5	
32	154347001	1	<7210,7220-90□,7230用> ヒザアゲレバーバネ	<For 7210, 7220-90□ & 7230> SPRING	
33	S31010001	1	ダンジク6.35	SHOULDER SCREW, SM6.35	
34	062671612	1	ナベコ357-40X16	SCREW, PAN SM3.57-40X16	

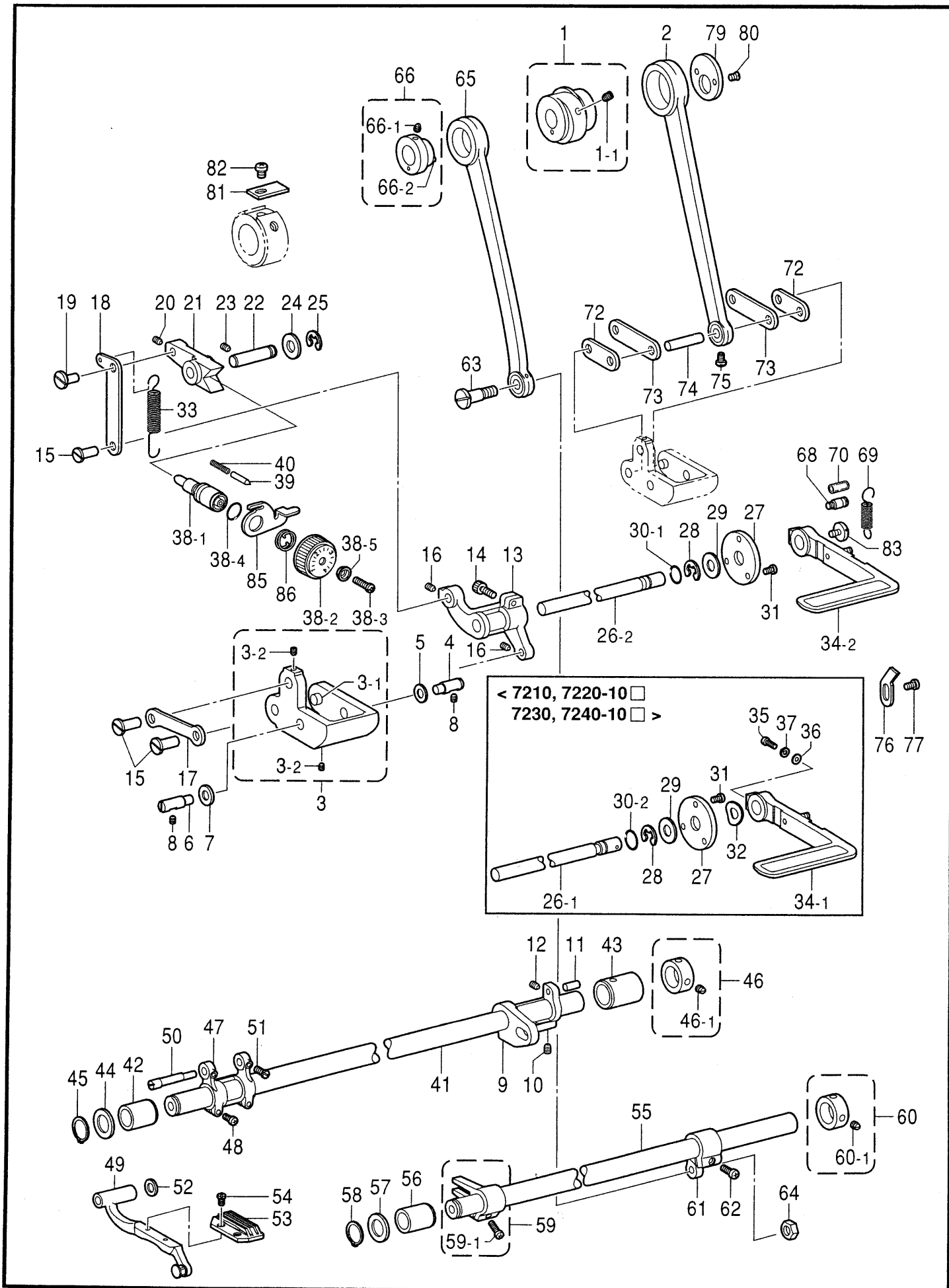

E. 送り関係 / Feed mechanism

REF.NO.	CODE	Q'TY	ヒンメイ	NAME OF PARTS	RM
1 1-1	S19135001 013761410	1 2	<7210-3, 7220-□03 用> ヘンシンリンネジツキ トメネジ5.95クボミ	<For 7210-3, 7220-□03> LEVEL FEED ECCENTRIC WHEEL W/S SET SCREW, (CP) SM5.95	
1 1-1	S16325001 013761410	1 2	<7210-5, 7220-□05 用> <7230, 7240 用> スイハイヘンシンリンネジツキ トメネジ5.95クボミ	<For 7210-5, 7220-□05> <For 7230, 7240> LEVEL FEED ECCENTRIC WHEEL W/S SET SCREW, (CP) SM5.95	
2 3 3-1 3-2 4 5 6 7 8 9 10 11 12 13 14 15 16 17 18 19 20 21 22 23 24 25	S16327001 S45842001 156951001 014680622 118734001 118735001 156967001 151439002 014760622 S16330101 014780622 156958001 014680622 S16333100 S07959001 151308101 014680422 S16331001 S16332001 S07656001 014680622 S16334001 156970001 014761030 S02556001 048070342	1 1 2 2 1 1 1 2 1 2 1 1 1 1 3 2 1 1 1 1 1 1 1 1 1 1 1	スイハイオクリレンカン キリカエキクミ オクリリンクジク アナトメネジ4.37クボミ キリカエキジク ザガネ キリカエジクL ザガネ アナトメネジ5.95 スイハイオクリウデ アナトメネジ6.35クボミ スイハイオクリウデジク アナトメネジ4.37クボミ キリカエキレバー アナホルト476-32X14 レンカンジク12.5 アナトメネジ4.37クボミ キリカエキレンカンD キリカエキレンカンU ヘンシンピン アナトメネジ4.37クボミ オクリチヨウセツキ オクリチヨウセツキジク アナクボミ595-28X10 ザガネ トメワE7	LEVEL FEED CONNECTING ROD FEED REGULATOR ASSY FEED LINK STUD SET SCREW, SOCKET (CP) SM4.37 FEED REGULATOR SHAFT WASHER, PLAIN 6 FEED REGULATOR SHAFT, L WASHER SET SCREW, SOCKET SM5.95 FEED ROCKER ARM SET SCREW, SOCKET (CP) SM6.35 STUD, FEED ROCKER ARM SET SCREW, SOCKET (CP) SM4.37 FEED REGULATOR LEVER BOLT, SOCKET SM4.76-32X14 CONNECTING STUD, 12.5 SET SCREW, SOCKET (CP) SM4.37 F-REGULATOR CONNECTING ROD, D F-REGULATOR CONNECTING ROD, U PIN SET SCREW, SOCKET (CP) SM4.37 FEED REGULATOR FEED REGULATOR SHAFT SET SCREW, SOCKET (CP) SM5.95 WASHER RETAINING RING, E7	
26-1	S32922001	1	<7210, 7220-10□用> <7230, 7240-10□用> カエシヌイレバージク	<For 7210, 7220-10□> <For 7230, 7240-10□> SHAFT, REVERSE LEVER	
26-2	S33681001	1	<7220-30□,-40□, -90□用> <7240-30□,-40□, -90□用> カエシヌイレバージク	<For 7220-30□, -40□, -90□> <For 7240-30□, -40□, -90□> SHAFT, REVERSE LEVER	
27 28 29	147504201 048080342 025100132	1 1 1	カンザ トメワE8 ヒラザガネシヨウ10	SPACER RETAINING RING, E8 WASHER, PLAIN S 10	
30-1 32	104564001 213765001	1 1	<7210, 7220-10□用> <7230, 7240-10□用> Oリング ナミワ02X10.5X20	<For 7210, 7220-10□> <For 7230, 7240-10□> O RING WAVE RING, 02X10.5X20	
30-2	S33680001	1	<7220-30□,-40□, -90□用> <7240-30□,-40□, -90□用> Oリング	<For 7220-30□, -40□, -90□> <For 7240-30□, -40□, -90□> O RING	

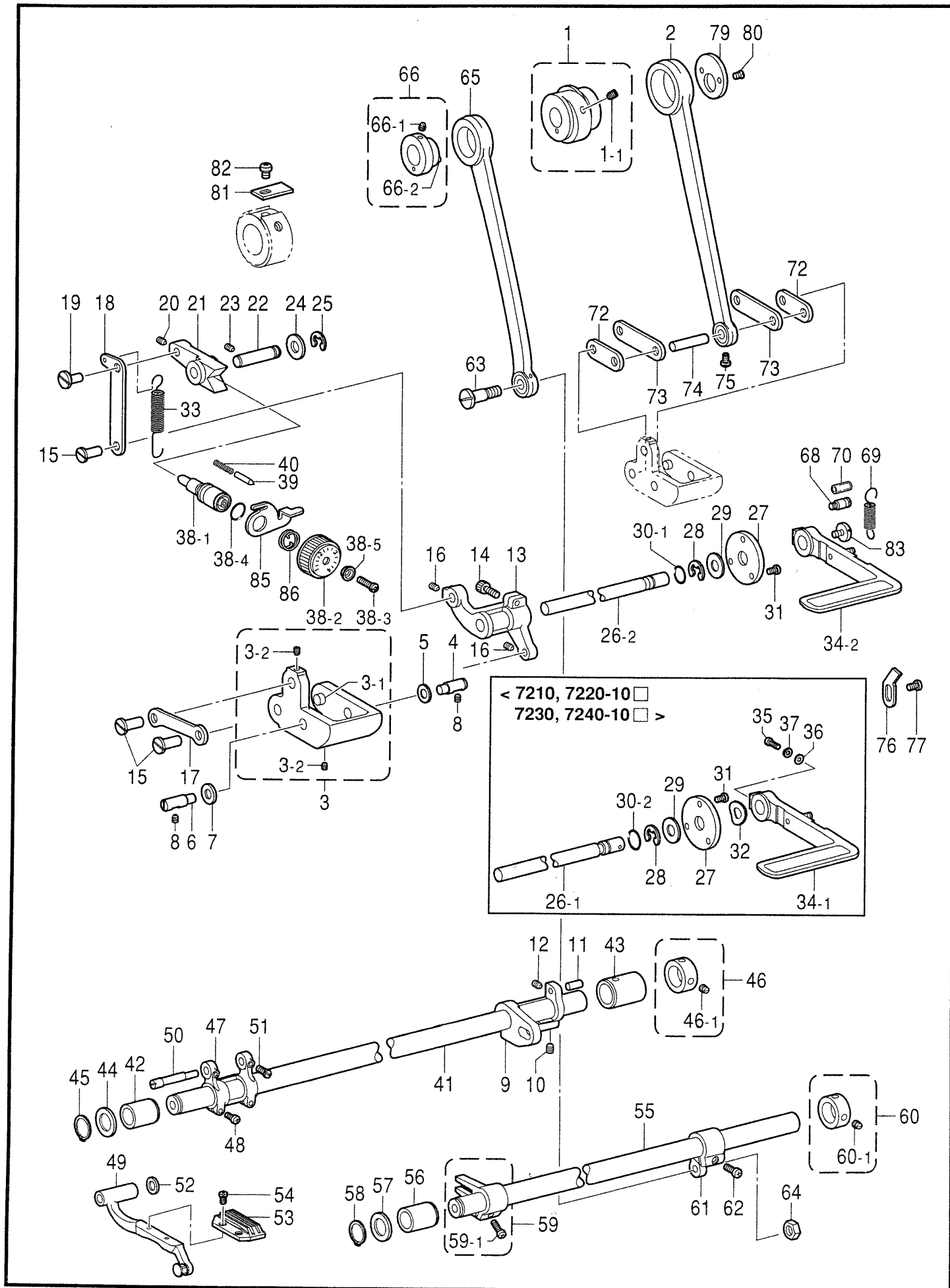

E. 送り関係 / Feed mechanism

REF.NO.	CODE	Q'TY	ヒンメイ	NAME OF PARTS	RM
31	062670712	3	ナベコ357-40X7	SCREW, PAN SM3.57-40X7	
33	S11170001	1	ヒキバネ	SPRING	
34-1	S45838001	1	<7210, 7220-10□用> <7230, 7240-10□用> カエシヌイレバークミ	<For 7210, 7220-10□> <For 7230, 7240-10□> REVERSE STITCHING LEVER ASSY	
35	S37333001	1	ナベコ4.76-32X14	SCREW, PAN SM4.76-32X14	
36	153484001	1	ザガネ4.76	WASHER, PLAIN 4.76	
37	028050240	1	バネザガネ2-5	WASHER, SPRING 2-5	
34-2	S45840101	1	<7220-30□,-40□, -90□用> <7240-30□,-40□, -90□用> カエシヌイレバークミ	<For 7220-30□, -40□, -90□> <For 7240-30□, -40□, -90□> REVERSE STITCHING LEVER ASSY	
38	S50100001	1	<7210-3, 7220-□03 用> オクリメモリダイヤルクミ	<For 7210-3, 7220-□03> STITCH LENGTH DIAL ASSY	
38-1	S50099001	1	オクリチヨウセツネジ	ADJUSTING SCREW	
38-2	S31016001	1	オクリメモリダイヤル目盛	STITCH LENGTH DIAL, 4Marked in	
38-3	S21514101	1	シメネジ4.76	SCREW, SM4.76	
38-4	108549001	1	オリング	O RING	
38-5	142746002	1	メモリイタオサエ	SUPPORT PLATE	
38	S50101001	1	<7210-5, 7220-□05 用> オクリメモリダイヤルクミ	<For 7210-5, 7220-□05> STITCH LENGTH DIAL ASSY, 5	
38-1	S50099001	1	オクリチヨウセツネジ	ADJUSTING SCREW	
38-2	S31019001	1	オクリメモリダイヤル目盛	STITCH LENGTH DIAL, 5Marked in	
38-3	S21514101	1	シメネジ4.76	SCREW, SM4.76	
38-4	108549001	1	オリング	O RING	
38-5	142746002	1	メモリイタオサエ	SUPPORT PLATE	
38	S50102001	1	<7230, 7240 用> オクリメモリダイヤルクミ	<For 7230, 7240> STITCH LENGTH DIAL ASSY, 6	
38-1	S50099001	1	オクリチヨウセツネジ	ADJUSTING SCREW	
38-2	S45905001	1	オクリメモリダイヤル目盛	STITCH LENGTH DIAL, 6Marked in	
38-3	S21514101	1	シメネジ4.76	SCREW, SM4.76	
38-4	108549001	1	オリング	O RING	
38-5	142746002	1	メモリイタオサエ	SUPPORT PLATE	
39	S50098001	1	メモリイチギメピン	POSITIONING PIN	
40	100328001	1	メモリイチキメピンバネ	SPRING	
41	S02568101	1	スイハイオクリジク	FEED ROCKER SHAFT	
42	S16432001	1	メタル18.8	BUSH, 18.8	
43	S31014000	1	メタル19.3	BUSH, 19.3	
44	224485000	1	ワ2X15X22ST	RING, 2X15X22ST	
45	048150142	1	トメワジクヨウC15	RETAINING RING, EXTERNAL C15	
46	183493001	1	オクリジクセツトカラークミ	SET SCREW COLLAR ASSY	
46-1	101706001	2	トメネジ6.35	SET SCREW, SM6.35	
47	156244020	1	スイハイオクリダイウデ	FEED ROCKER BRACKET ARM	
48	062681212	2	ナベコ437-40X12	SCREW, PAN SM4.37-40X12	
49	S11172101	1	オクリダイクミ	FEED BAR ASSY	
50	S25349021	1	オクリダイジク	FEED BAR SHAFT	
51	120990001	2	アタマツキトメネジ4.37	SET SCREW, SM4.37-40X8	
52	158722001	1	ザガネ4.2	WASHER, PLAIN 4.2	

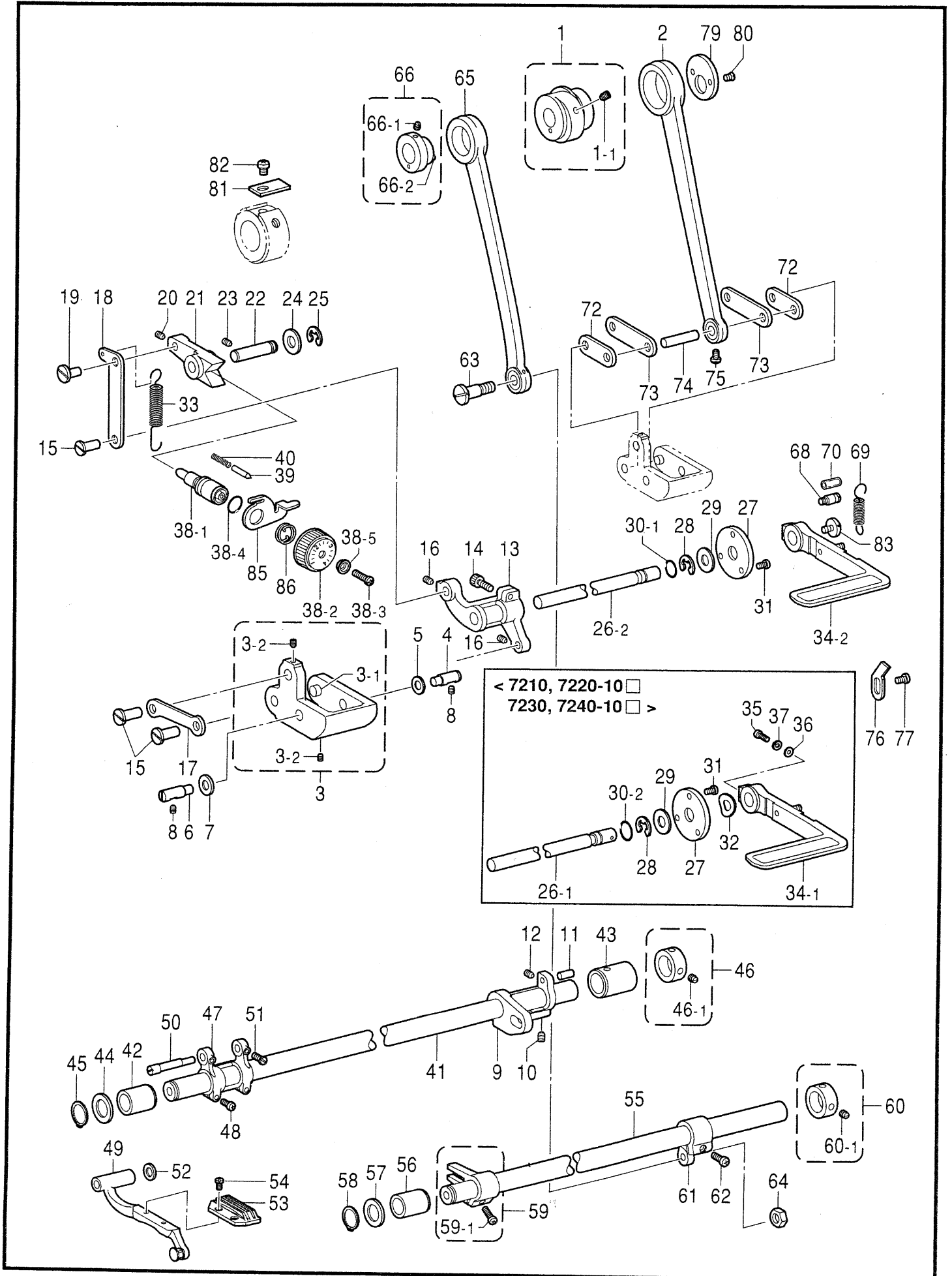

E. 送り関係 / Feed mechanism

REF.NO.	CODE	Q'TY	ヒンメイ	NAME OF PARTS	RM
53	S01158001	1	<7210-3 用> オクリバ	<For 7210-3> FEED DOG	
53	S01159001	1	オクリバ	FEED DOG	
53	S13102101	1	<7210-5, 7220-□05 用> オクリバ	<For 7210-5, 7220-□05> FEED DOG	
53	159525001	1	オクリバ	FEED DOG	
53	159521001	1	<7220-□03 用> オクリバ	<For 7220-□03> FEED DOG	
53	159525001	1	オクリバ	FEED DOG	
53	S45903001	1	<7230, 7240 用> オクリバ	<For 7230, 7240> FEED DOG	
54	100080003	2	シメネジ3.18	SCREW, SM3.18	
55	S02574101	1	ジヨウゲオクリジク	FEED LIFTING ROCKER SHAFT	
56	S31014000	1	メタル19.3	BUSH, 19.3	
57	224485000	1	ワ2X15X22ST	RING, 2X15X22ST	
58	048150142	1	トメワジクヨウC15	RETAINING RING, EXTERNAL C15	
59	180322001	1	ジヨウゲオクリウデクミ	F-LIFT. ROCK SHAFT CRANK ASSY	
59-1	062681412	1	ナベコ437-40X14	SCREW, PAN SM4.37-40X14	
60	183493001	1	オクリジクセットカラークミ	SET SCREW COLLAR ASSY	
60-1	101706001	2	トメネジ6.35	SET SCREW, SM6.35	
61	S02575000	1	ジヨウゲオクリジクウデ	F-LIFTING ROCK SHAFT CRANK	
62	062711212	1	ナベコ476-32X12	SCREW, PAN SM4.76-32X12	
63	147509001	1	ダンネジ7.14	SHOULDER SCREW, SM7.14	
64	104689002	1	ナツト7.14	NUT, SM7.14	
65	118758001	1	ジヨウゲオクリレンカン	FEED LIFTING CONNECTING ROD	
66-1	S02576001	1	<7210-3, 7220-□03 用> ヘンシンリンネジツキ	<For 7210-3, 7220-□03> ECCENTRIC WHEEL W/SCREW	
66-1-1	151604001	2	トメネジ5.95	SET SCREW, SM5.95	
66-1-2	047200642	1	スプリングピンAW2	PIN, SPRING ROLL AW2	
66-1	S19137001	1	<7210-5, 7220-□05 用> ヘンシンリンネジツキ	<For 7210-5, 7220-□05> ECCENTRIC WHEEL W/SCREW	
66-1-1	151604001	2	トメネジ5.95	SET SCREW, SM5.95	
66-1-2	047200642	1	スプリングピンAW2	PIN, SPRING ROLL AW2	
66-1	S45914001	1	<7230, 7240 用> ヘンシンリンネジツキ	<For 7230, 7240> ECCENTRIC WHEEL W/SCREW	
66-1-1	151604001	2	トメネジ5.95	SET SCREW, SM5.95	
66-1-2	047200642	1	スプリングピンAW2	PIN, SPRING ROLL AW2	
68	S02562001	1	バネカケ	SPRING HOOK	
69	S02563001	1	モドシバネ	SPRING	
70	153132000	1	ナイロンチューブ	NYLON TUBE	
72	S45832000	2	スイハイオクリリンク	FEED ROCKER LINK	
73	S32919000	2	スイハイオクリウデリンク	FEED ROCKER ARM LINK	
74	156956001	1	リンクジク	LINK SHAFT	
75	144458001	1	アタマツキトメネジ3.57	SET SCREW, SM3.57	
76	S01753001	1	ストツバ	STOPPER	
77	062680812	1	ナベコ437-40X8	SCREW, PAN SM4.37-40X8	
79	156948001	1	レンカンオサエ	CONNECTING ROD PRESSER	
80	108960002	2	サラネジ3.57	SCREW, FLAT SM3.57	
81	159690001	1	オクリカムストツパー	STOPPER, FEED CAM	
82	062670412	1	ナベコ357-40X4	SCREW, PAN SM3.57-40X4	

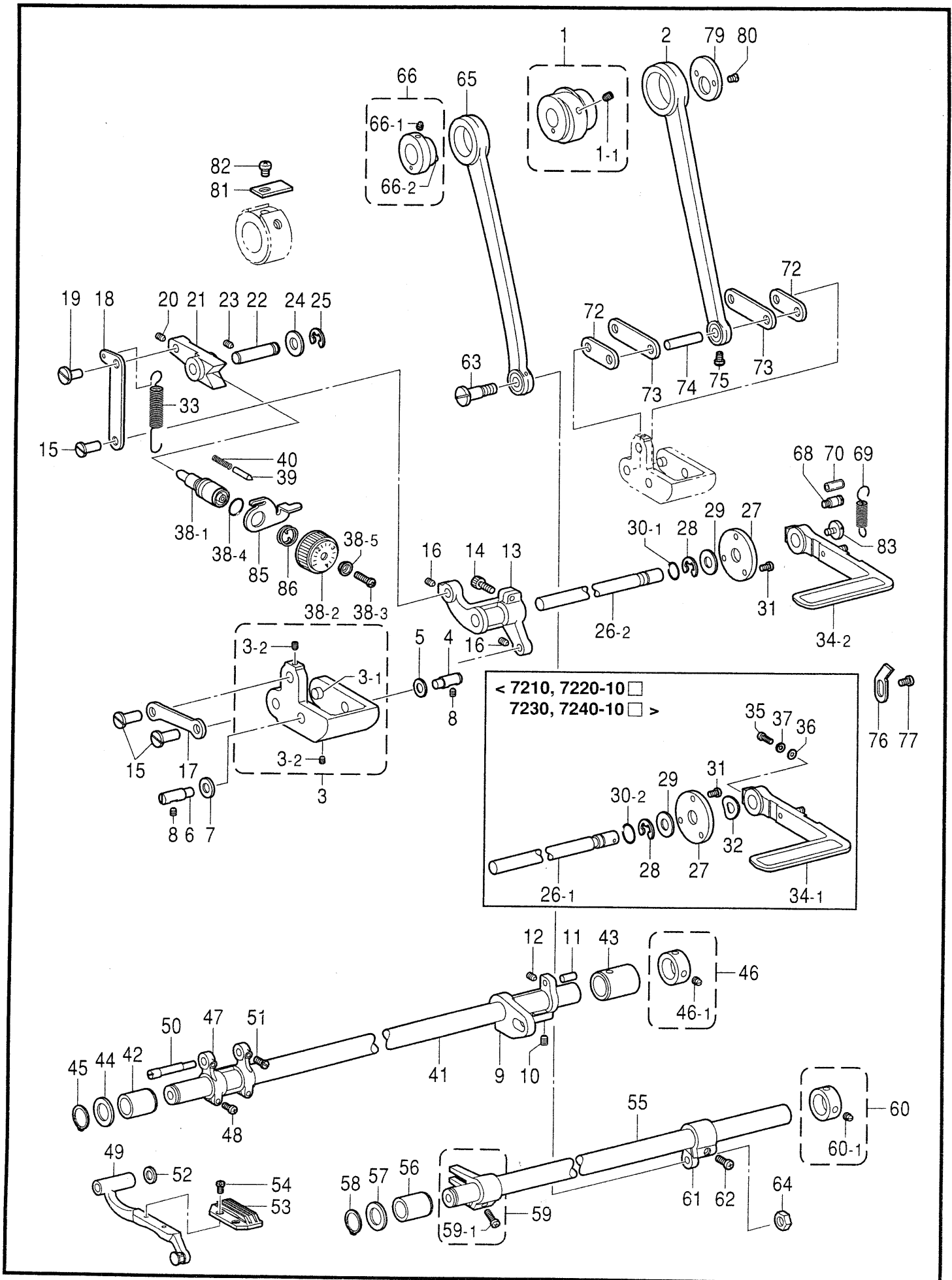

E. 送り関係 / Feed mechanism

REF.NO.	CODE	Q'TY	ヒンメイ	NAME OF PARTS	RM
83	100511003	1	<7220-30□, -40□, -90□用> <7240-30□, -40□, -90□用> シメネジ4.76	<For 7220-30□, -40□, -90□> <For 7240-30□, -40□, -90□> SCREW, SM4.76	
85 86	S39829001 S39830001	1 1	<7220, 7240 用> ダイアルロックレバー ダイアルロックレバーバネ	<For 7220, 7240> DIAL LOCK LEVER SPRING, DIAL LOCK LEVER	
53 53 53 53 53 53 53	159522001 159523001 159524001 159526001 159914001 S01989001 S03357001	1 1 1 1 1 1 1	" オプション部品 " オクリバ オクリバ オクリバ オクリバ オクリバ オクリバ オクリバ	" OPTION PARTS " FEED DOG FEED DOG FEED DOG FEED DOG FEED DOG FEED DOG FEED DOG	

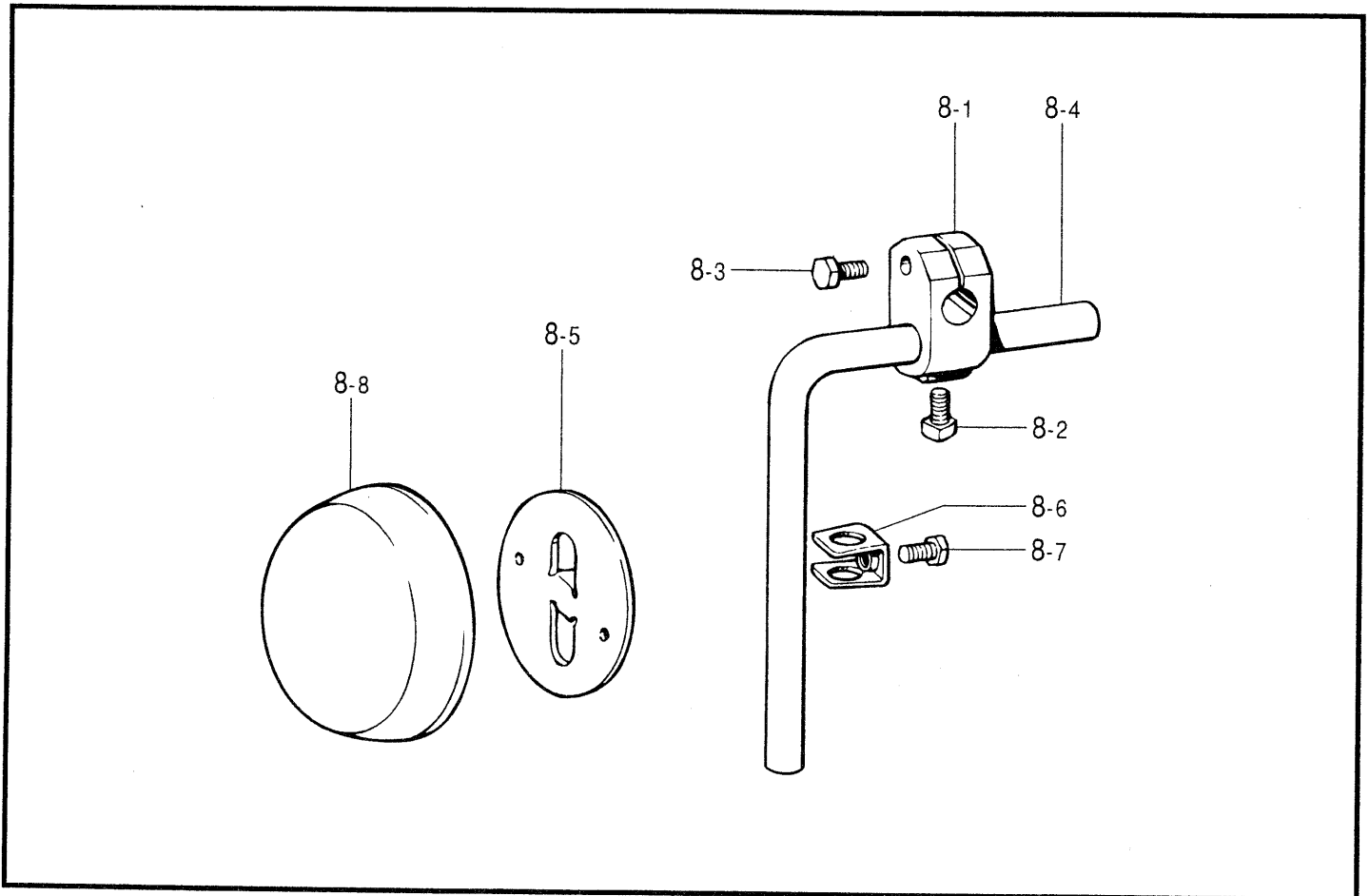

117-722-203

G. 逆転関係 (7220, 7240: -30□, -40□, -90□用)
 / Quick reverse mechanism (7220, 7240: -30□, -40□, -90□)

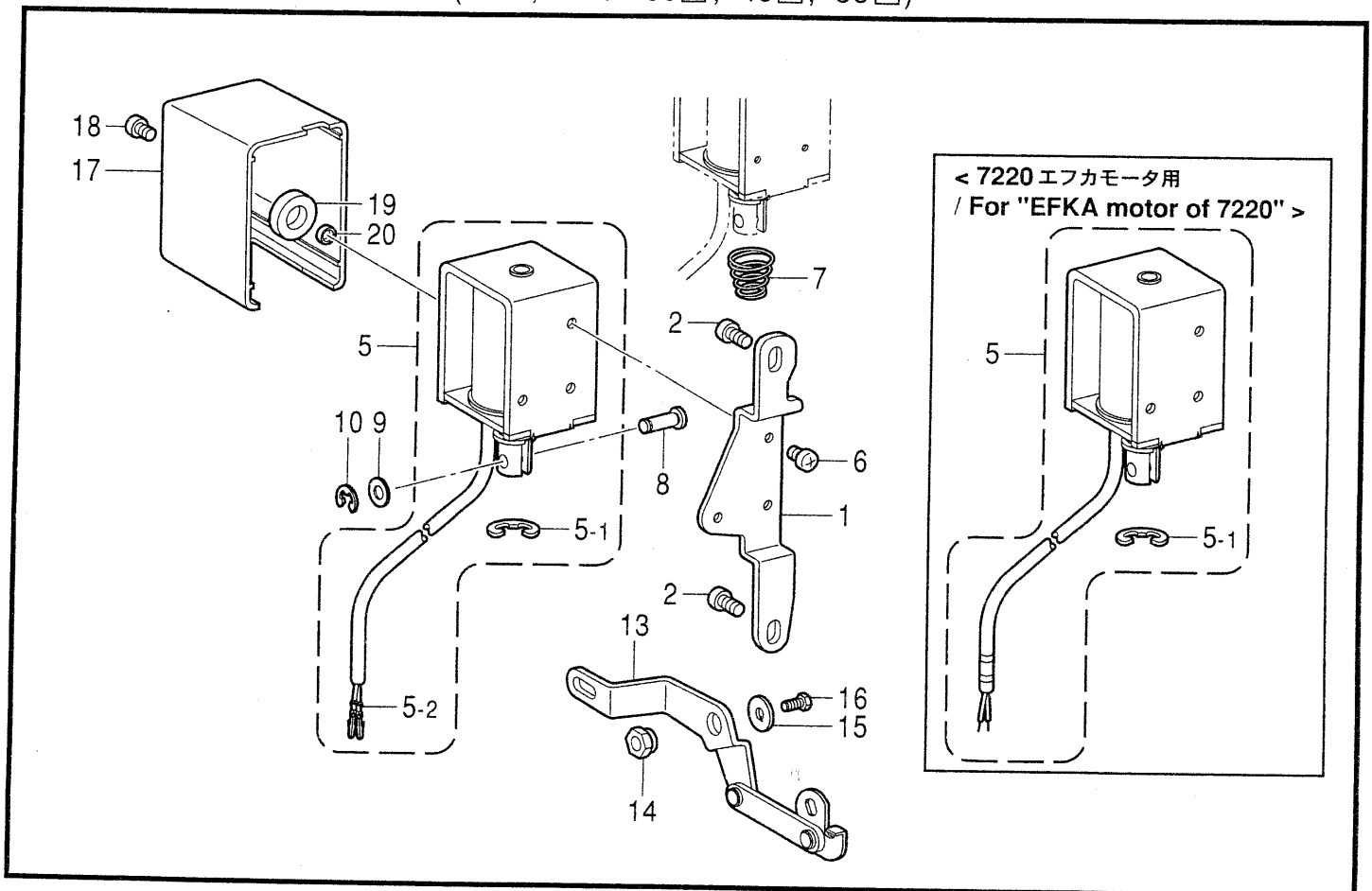

117-722-205

F. 膝上ゲ関係 / Knee lifter mechanism

REF.NO.	CODE	Q'TY	ヒンメイ	NAME OF PARTS	RM
8	S34758001	1	<7210, 7230 用> <7220-10□, -30□, -40□ 用> <7240-10□, -30□, -40□ 用>	<For 7210, 7230> <For 7220-10□, -30□, -40□> <For 7240-10□, -30□, -40□>	
8-1	146039001	1	ヒザアテクミ	KNEE LIFTER ASSY	
8-2	100463001	1	ヒザアテツギテ	BRACKET, KNEE LIFTER	
8-3	100463001	1	カクボルト7.94	BOLT, SQUARE SM7.94	
8-4	017762013	1	ボルト5.95X20	BOLT, SM5.95X20	
8-4	104619002	1	ヒザアゲタテジク	KNEE LIFTER BAR	
8-5	S34756001	1	ヒザアテ	KNEE LIFTER PLATE	
8-6	114967001	1	ヒザアテストツハ	STOPPER, K-LIFTER PLATE	
8-7	110087001	1	ボルト5.95	BOLT, SM5.95X8	
8-8	S31885001	1	ヒザアテカバー	COVER, KNEE LIFTER PLATE	

117-722-203

G. 逆転関係 (7220, 7240: -30□, -40□, -90□)

/Quick reverse mechanism (7220, 7240: -30□, -40□, -90□)

REF.NO.	CODE	Q'TY	ヒンメイ	NAME OF PARTS	RM
1	S45843001	1	カエシヌイソレノイドダイ	REVERSE SOLENOID BRACKET	
2	062781412	2	ナベコ635-28X14	SCREW, PAN SM6.35-28X14	
5	S13688009	1	<DCモータ用> ギヤクテンソレノイドクミ	<For "DC motor"> QUICK REVERSE SOLENOID ASSY	
5-1	154730001	1	トメワE15	RETAINING RING, E15	
5-2	143549000	2	ピンターミナルオス	TERMINAL PIN, MALE	
5	S13690009	1	<7220 エフカモータ用> -----	<For "EFKA motor of 7220"> QUICK REVERSE SOLENOID ASSY	
5-1	154730001	1	-----	RETAINING RING, E15	
5	S13691009	1	<7220 エフカモータ AC用> -----	<For "EFKA AC-motor of 7220"> QUICK REVERSE SOLENOID ASSY	
5-1	154730001	1	-----	RETAINING RING, E15	
5-2	143549000	2	ピンターミナルオス	TERMINAL PIN, MALE	
6	062500812	3	ナベコ5X8	SCREW, PAN M5X8	
7	S13654001	1	ソレノイドオサエバネ	SPRING	
8	153245001	1	レンケツピン	PIN	
9	153138001	1	ザガネ	WASHER, PLAIN 6.5	
10	048040342	1	トメワE4	RETAINING RING, E4	
13	S11174001	1	レバークミ	REVERSE LINK LEVER ASSY	
14	149094001	1	ソレノイドレバージク	STUD, SOLENOID LEVER	
15	149095001	1	ザガネ	WASHER, PLAIN 6	
16	S13665001	1	ボルト635-28X18	BOLT, SM6.35-28X18	
17	146105009	1	ソレノイドカバー	SOLENOID COVER	
18	062500602	1	ナベコ5X6	SCREW, PAN M5X6	
19	S01327001	1	ソレノイドゴム	RUBBER, REVERSE SOLENOID	
20	S01328001	1	カラー	COLLAR	

117-722-205

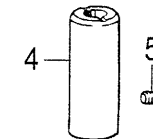
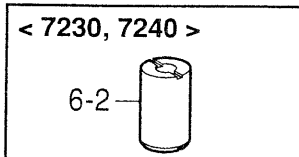
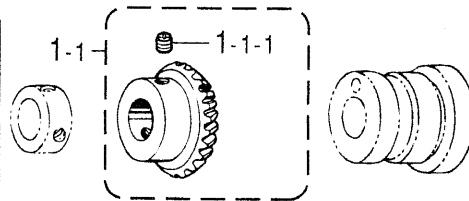
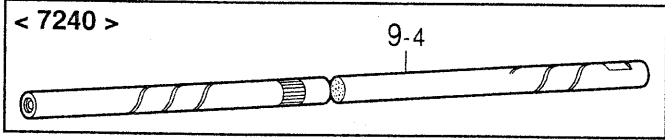
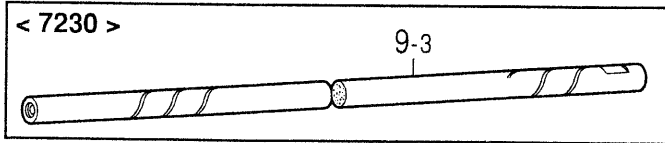
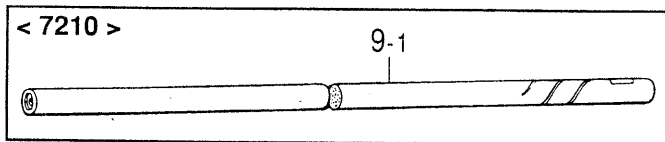

5

3-1

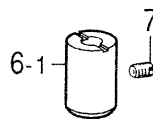
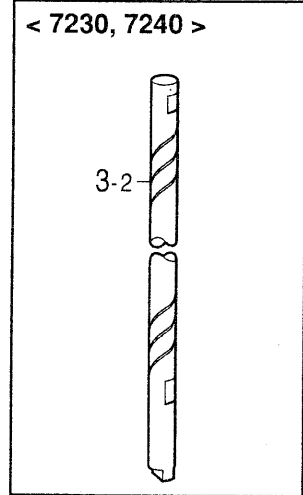

7

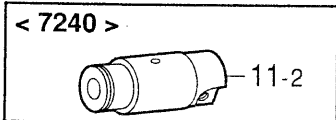
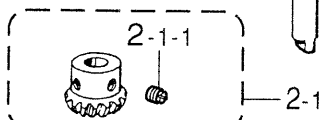
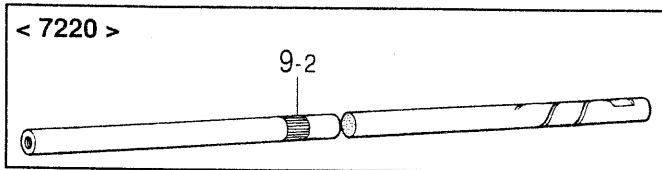

11-1

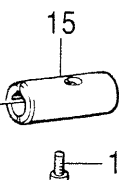
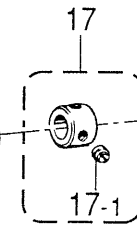
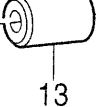
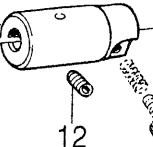

16

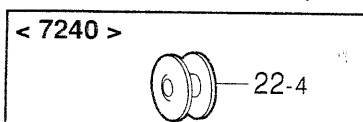
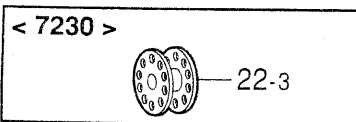
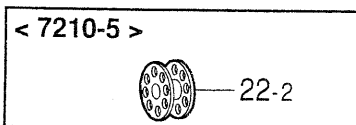
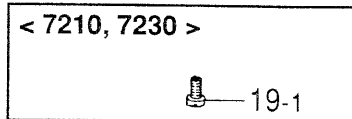
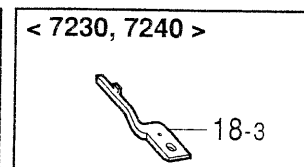
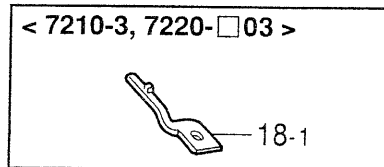
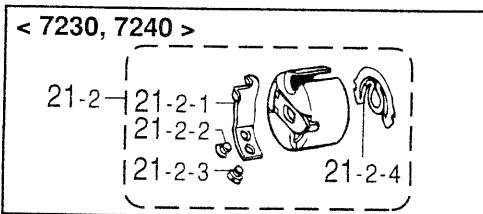
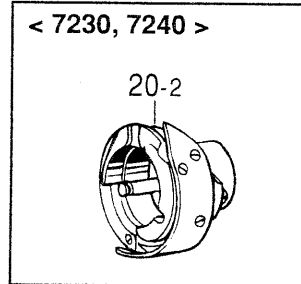
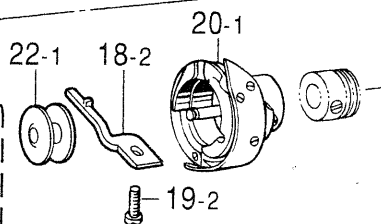
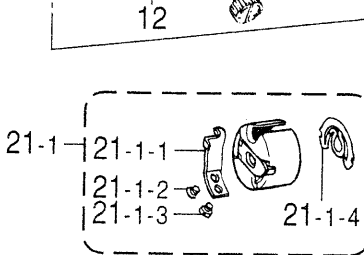
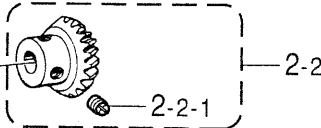

H. カマ関係 / Rotary hook mechanism

REF.NO.	CODE	Q'TY	ヒンメイ	NAME OF PARTS	RM
1-1	180891001	1	ウワジクベベルギヤクミ	UPPER SHAFT BEVEL GEAR ASSY	
1-1-1	100251001	2	トメネジ6.35	SET SCREW, SM6.35	
1-2	180892001	1	タテジクカサハグルマUクミ	VERTICAL BEVEL GEAR ASSY, U	
1-2-1	100251001	2	トメネジ6.35	SET SCREW, SM6.35	
2-1	180885001	1	タテジクカサハグルマDクミ	VERTICAL BEVEL GEAR ASSY, D	
2-1-1	100251001	2	トメネジ6.35	SET SCREW, SM6.35	
2-2	180886001	1	シタジクベベルギヤクミ	LOWER SHAFT BEVEL GEAR ASSY	
2-2-1	100251001	2	トメネジ6.35	SET SCREW, SM6.35	
3-1	145516001	1	<7210, 7220 用> タテジク	<For 7210, 7220> VERTICAL SHAFT	
3-2	159789001	1	<7230, 7240 用> タテジク	<For 7230, 7240> VERTICAL SHAFT	
4	142708000	1	タテジクメタルU	VERTICAL SHAFT BUSH, U	
5	013760610	1	トメネジ5.95クボミ	SET SCREW, (CP) SM5.95	
6-1	531026000	1	<7210, 7220 用> タテジクメタルD	<For 7210, 7220> VERTICAL SHAFT BUSH, D	
6-2	159790000	1	<7230, 7240 用> タテジクメタルD	<For 7230, 7240> VERTICAL BUSH, D	
7	013761410	1	トメネジ5.95クボミ	SET SCREW, (CP) SM5.95	
9-1	109160001	1	<7210 用> シタジク	<For 7210> LOWER SHAFT	
9-2	154552001	1	<7220 用> シタジク	<For 7220> LOWER SHAFT	
9-3	500857001	1	<7230 用> シタジク	<For 7230> LOWER SHAFT	
9-4	159791001	1	<7240 用> シタジク	<For 7240> LOWER SHAFT	
10	109173101	1	オイルアナフタネジ	CAP SCREW, OIL	
11-1	118761001	1	<7210, 7220, 7230 用> シタジクメタルL	<For 7210, 7220, 7230> LOWER SHAFT BUSH, L	
11-2	159792000	1	<7240 用> シタジクメタルL	<For 7240> LOWER SHAFT BUSH LEFT	
12	014680622	1	アナトメネジ4.37クボミ	SET SCREW, SOCKET (CP) SM4.37	
13	531027000	1	シタジクメタルM	BUSH, M L-SHAFT	
15	104520000	1	シタジクメタルR	LOWER SHAFT BUSH, R	
16	121007001	1	アタマツキトメネジ4.37	SET SCREW, SM4.37	
17	181995001	1	セツトカラークミ	SET SCREW COLLAR ASSY	
17-1	101706001	2	トメネジ6.35	SET SCREW, SM6.35	
18-1	100367001	1	<7210-3, 7220-□03 用> ウチカマトメ	<For 7210-3, 7220-□03> B-CASE HOLDER POSITION BRACKET	
18-2	159324001	1	<7210-5, 7220-□05 用> ウチカマトメ	<For 7210-5, 7220-□05> B-CASE HOLDER POSITION BRACKET	

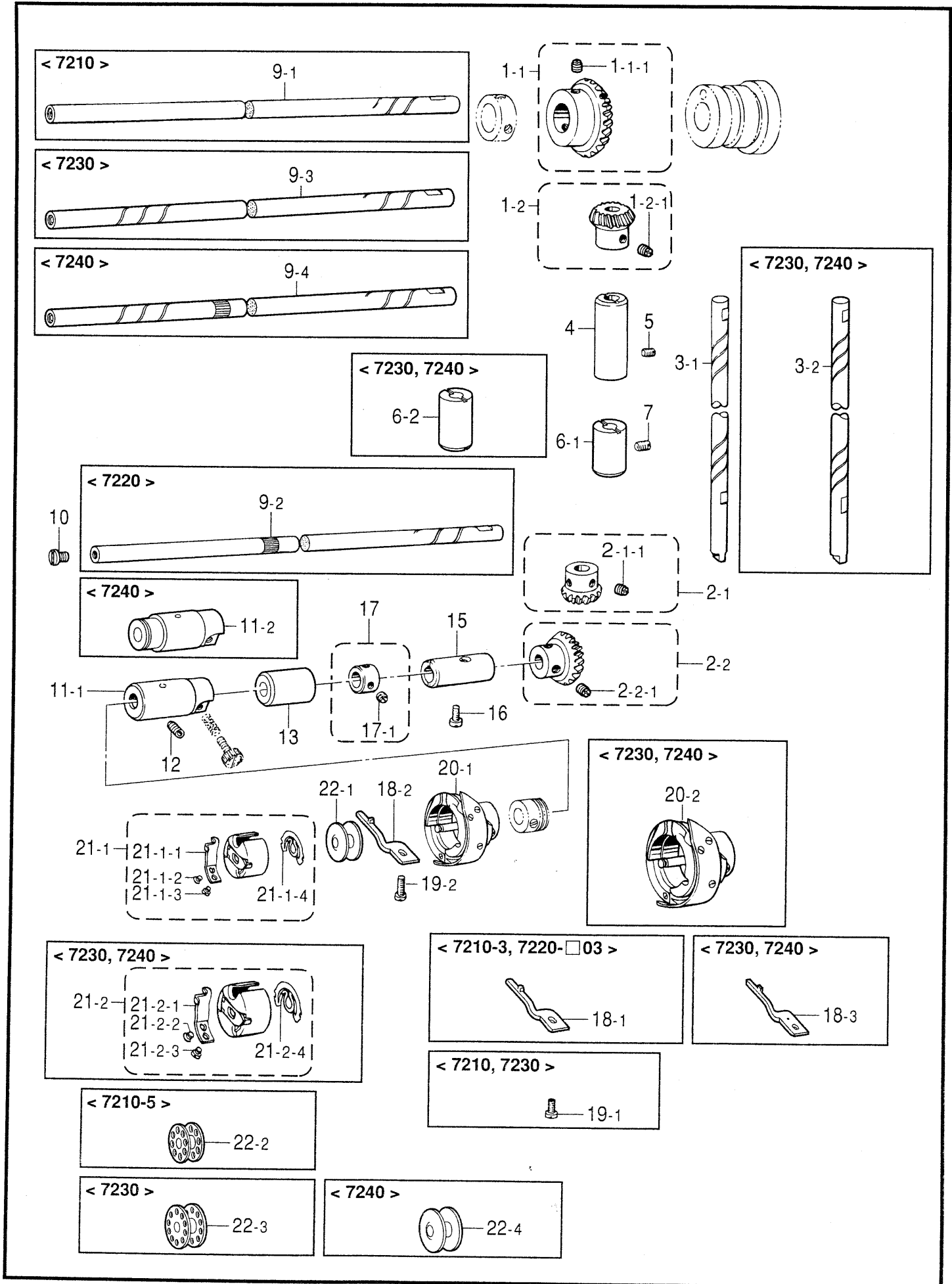

H. カマ関係 / Rotary hook mechanism

REF.NO.	CODE	Q'TY	ヒンメイ	NAME OF PARTS	RM
18-3	147337001	1	<7230, 7240 用> ウチカマトメ	<For 7230, 7240> B-CASE HOLDER POSITION BRACKET	
19-1	107407003	1	<7210, 7230 用> シメネジ4.37	<For 7210, 7230> SCREW, SM4.37X9	
19-2	062681212	1	<7220, 7240 用> ナベコ437-40X12	<For 7220, 7240> SCREW, PAN SM4.37-40X12	
20-1	S45911901	1	<7210-3 用> コウソクカマハコクミ	<For 7210-3> ROTARY HOOK ASSY, W/BOX	
20-1	140882901	1	<7210-5 用> コウソクカマハコクミ	<For 7210-5> ROTARY HOOK ASSY, W/BOX	
20-1	S45912901	1	<7220-□03 用> コウソクカマハコクミ	<For 7220-□03> ROTARY HOOK ASSY, W/BOX	
20-1	148846901	1	<7220-□05 用> コウソクカマハコクミ	<For 7220-□05> ROTARY HOOK ASSY, W/BOX	
20-2	S45918901	1	<7230 用> コウソクカマBハコクミ	<For 7230> ROTARY HOOK ASSY, B W/BOX	
20-2	159793901	1	<7240 用> コウソクカマB1ハコクミ	<For 7240> ROTARY HOOK ASSY, B1 W/BOX	
21-1	148350101	1	<7210-3, 7220-□03 用> ボビンケースクミ	<For 7210-3, 7220-□03> BOBBIN CASE ASSY	
21-1-1	183291001	1	ボビンケースチヨウシバネ	TENSION SPRING	
21-1-2	183292001	1	チヨウシバネチヨウセツネジ	ADJUSTING SCREW	
21-1-3	183293001	1	チヨウシバネトメネジ	SET SCREW	
21-1-4	148967101	1	クウテンボウシバネ	SPRING, ANTI-SPIN	
21-1	S20553001	1	<7210-5, 7220-□05 用> ボビンケースクミ	<For 7210-5, 7220-□05> BOBBIN CASE ASSY	
21-1-1	183291001	1	ボビンケースチヨウシバネ	TENSION SPRING	
21-1-2	183292001	1	チヨウシバネチヨウセツネジ	ADJUSTING SCREW	
21-1-3	183293001	1	チヨウシバネトメネジ	SET SCREW	
21-1-4	148967101	1	クウテンボウシバネ	SPRING, ANTI-SPIN	
22-1	146290001	1	<7210-3 用> <7220-□03, -□05 用> ボビン	<For 7210-3> <For 7220-□03, -□05> BOBBIN	
22-2	117132001	1	<7210-5 用> ボビン	<For 7210-5> BOBBIN	
21-2	147790001	1	<7230 用> ボビンケースクミ	<For 7230> BOBBIN CASE ASSY	
21-2-1	183291001	1	ボビンケースチヨウシバネ	TENSION SPRING	
21-2-2	183292001	1	チヨウシバネチヨウシネジ	ADJUSTING SCREW	
21-2-3	183293001	1	チヨウシバネトメネジ	SET SCREW	
21-2-4	148967101	1	クウテンボウシバネ	SPRING, ANTI-SPIN	
22-3	117061001	1	ボビン	BOBBIN	
21-2	151845001	1	<7240 用> ボビンケースクミ	<For 7240> BOBBIN CASE ASSY	
21-2-1	151845001	1	ボビンケースチヨウシバネ	TENSION SPRING	
21-2-2	181937001	1	チヨウシバネチヨウシネジ	ADJUSTING SCREW	
21-2-3	181938001	1	チヨウシバネトメネジ	SET SCREW	
21-2-4	151844001	1	クウテンボウシバネ	SPRING, ANTI-SPIN	
22-4	159794001	1	ボビン	BOBBIN	

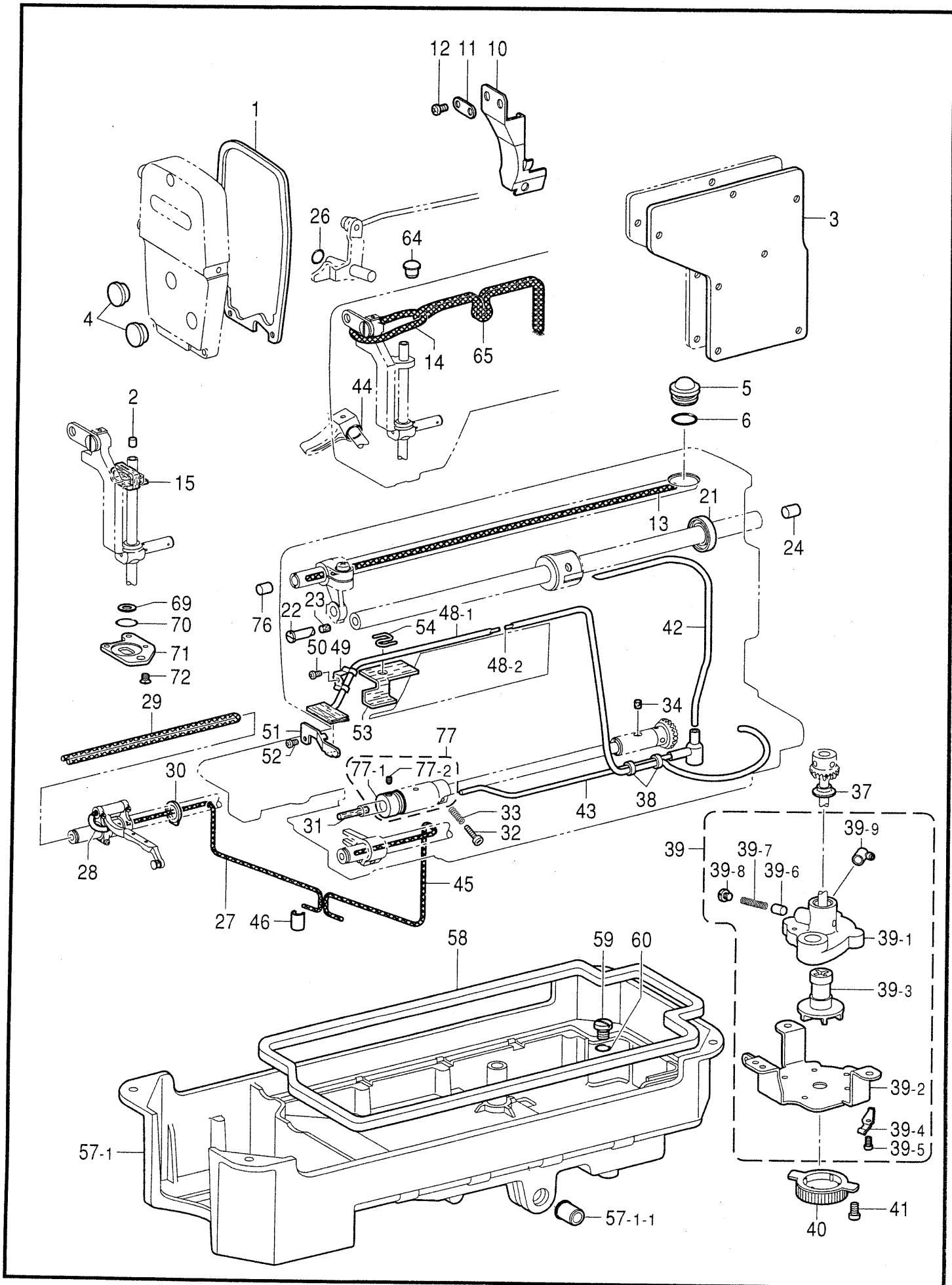

J1. 給油潤滑関係 / Lubrication

REF.NO.	CODE	Q'TY	ヒンメイ	NAME OF PARTS	RM
1	S45844000	1	メンイタバツキン	PACKING, FACE PLATE	
2	S04630000	1	<7210-3, 7220-□03 用> ハリボウセン	<For 7210-3, 7220-□03> CORK, NEEDLE BAR	
2	111863001	1	<7210-5, 7220-□05 用> <7230, 7240 用> ハリボウセン	<For 7210-5, 7220-□05> <For 7230, 7240> CORK, NEEDLE BAR	
3	S02605000	1	ガワイタバツキン	REAR COVER PACKING	
4	104449009	2	ゴムセン15.5	RUBBER CAP, 15.5	
5	S02606000	1	ユリヨウケイマド	OIL GAUGE WINDOW	
6	081014670	1	OリングPW14	O RING, PW14	
10	S32930000	1	テンビンオイルヨケイタ	OIL STOPPER PLATE, TR TAKE-UP	
11	S32926001	1	オイルヨケイタオサエ	HOLDER, OIL STOPPER	
12	062670612	2	ナベコ357-40X6	SCREW, PAN SM3.57-40X6	
13	S45845000	1	クミヒモ	WICK, L = 415	
14	S45846000	1	クミヒモ	WICK, L = 130	
15	S16397100	1	<7210, 7220 用> ハリボウダイフェルト	<For 7210, 7220> FELT, N-BAR BRACKET	
21	101487000	1	オイルシール	OIL SEAL	
22	146333001	1	オイルチヨウセツベン	OIL REGULATOR VALVE	
23	146327001	1	フェルト7X10	FELT, 7X10	
24	156641001	1	ゴムセン7.4	RUBBER CAP, 7.4	
26	081001670	1	OリングPW1	O RING, PW1	
27	S40017000	1	クミヒモ360	WICK, L = 360	
28	S40016001	1	ビニルチューブ2X25	OIL TUBE, 2X25	
29	S43669000	1	クミヒモ8-320	WICK, 8 L = 320	
30	146064000	1	オイルキリ	OIL REJECTOR	
31	106436001	1	<7210, 7230, 7240 用> フェルト	<For 7210, 7230, 7240> FELT	
31	145751001	1	<7220 用> フェルト	<For 7220> FELT	
32	145534001	1	オイルチヨウセツネジ	ADJUSTING SCREW	
33	116794001	1	オシバネ	SPRING, COMPRESSION	
34	107155001	1	フェルト	FELT	
37	146196001	1	アブラヨケ	OIL STOPPER	
38	146253000	2	チューブ	TUBE, L5	
39	183850001	1	ポンプタイクミ	PUMP BODY ASSY	
39-1	S32348001	1	ポンプタイ	PUMP BODY	
39-2	144869002	1	ポンプキヤク	PUMP SUPPORT	
39-3	148849001	1	ポンプカイテンヨク	PUMP PROPELLER	
39-4	144874001	2	フィルターバネ	SPRING	
39-5	062670812	4	ナベコ3.57-40X8	SCREW, PAN SM3.57-40X8	
39-6	144875001	1	プランジャー	PLUNGER	
39-7	144876001	1	プランジャーバネ	SPRING, COMPRESSION	
39-8	112467002	1	シメネジ6.35	SCREW, SM6.35X5	
39-9	144878001	1	チューブジョイントB	OIL TUBE JOINT, B	
40	144872101	1	ポンプフィルター	PUMP FILTER	
41	062680812	3	ナベコ437-40X8	SCREW, PAN SM4.37-40X8	
42	S02609100	1	オイルチューブU	OIL TUBE, U	

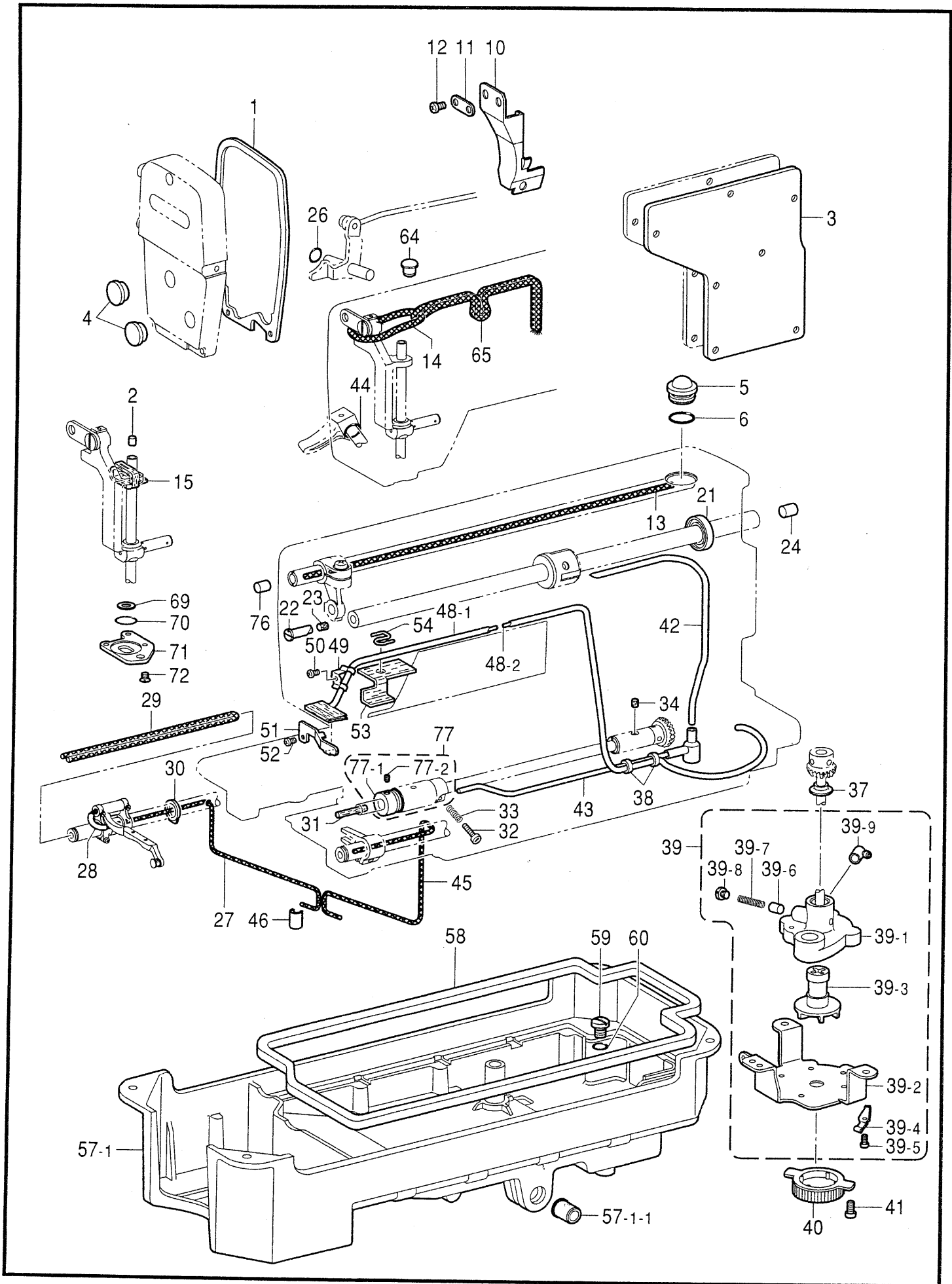

J1. 給油潤滑関係 / Lubrication

REF.NO.	CODE	Q'TY	ヒンメイ	NAME OF PARTS	RM
43	S32349001	1	オイルチューブDクミ	OIL TUBE ASSY, D	
44	081004070	1	OリングP4	O RING, P4	
45	S08003000	1	クミヒモ	WICK, L = 380	
46	S08004001	1	クミヒモササエ	WICK SUPPORT	
48	S45850001	1	チューブワイヤークミ	TUBE & WIRE ASSY	
48-1	S45876001	1	チューブクミH	TUBE ASSY, H	
48-2	S45854000	1	ワイヤー	WIRE	
49	151429001	1	チューブホルダ	TUBE HOLDER	
50	062670616	1	ナベコ357-40X6	SCREW, PAN SM3.57-40X6	
51	S45848001	1	チューブオサエ	TUBE SUPPORT	
52	062670612	1	ナベコ357-40X6	SCREW, PAN SM3.57-40X6	
53	S45851000	1	フェルト	FELT	
54	S45856001	1	フェルトオサエ	FELT SUPPORT	
57-1	149580571	1	オイルパン	OIL PAN	
57-1-1	149578000	2	ヨコジクブツシュ	BUSH	
58	146040001	1	オイルパツキング	PACKING	
59	140518001	1	シメネジ7.94	SCREW, SM7.94X10	
60	081007070	1	OリングP7	O RING, P7	
64	111865009	1	セン6	CAP, 6	
65	S45849000	1	クミヒモ	WICK, L = 300	
69	159534000	1	ハリボウアブラクリ	OIL REJECTOR, N-BAR	
70	159535000	1	Oリング	O RING	
71	159536101	1	ハリボウアブラクリフタ	OIL REJECTOR COVER, N-BAR	
72	141542001	3	サラネジ3.18	SCREW, FLAT SM3.18X4	
76	156217009	1	ゴムセン8.5	RUBBER CAP, 8.5	
77	S06684001	1	カマアブラクリクミ	OIL REJECTOR ASSY	
77-1	S02608001	1	カマアブラクリ	OIL REJECTOR	
77-2	014680422	2	アナトメネジ4.37クボミ	SET SCREW, SOCKET (CP) SM4.37	

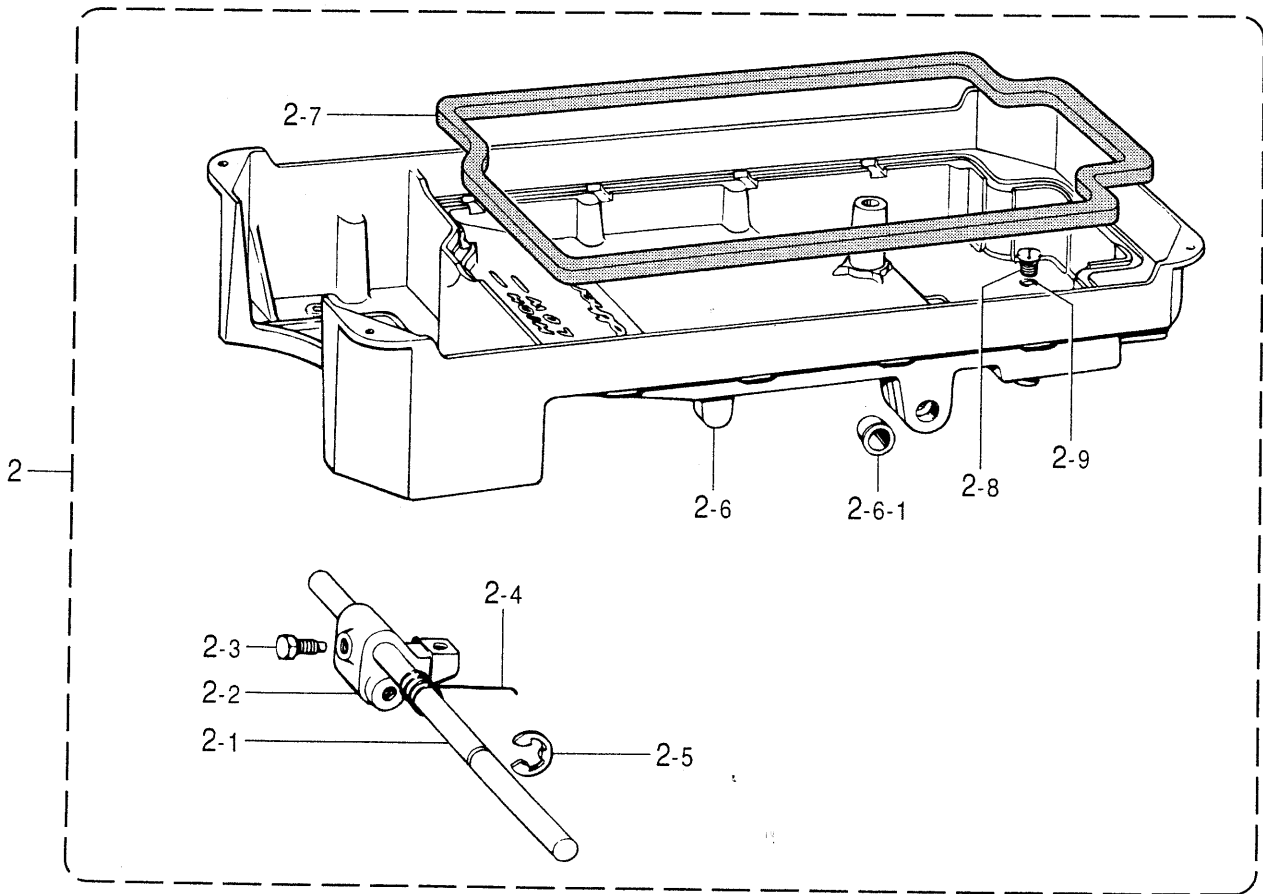
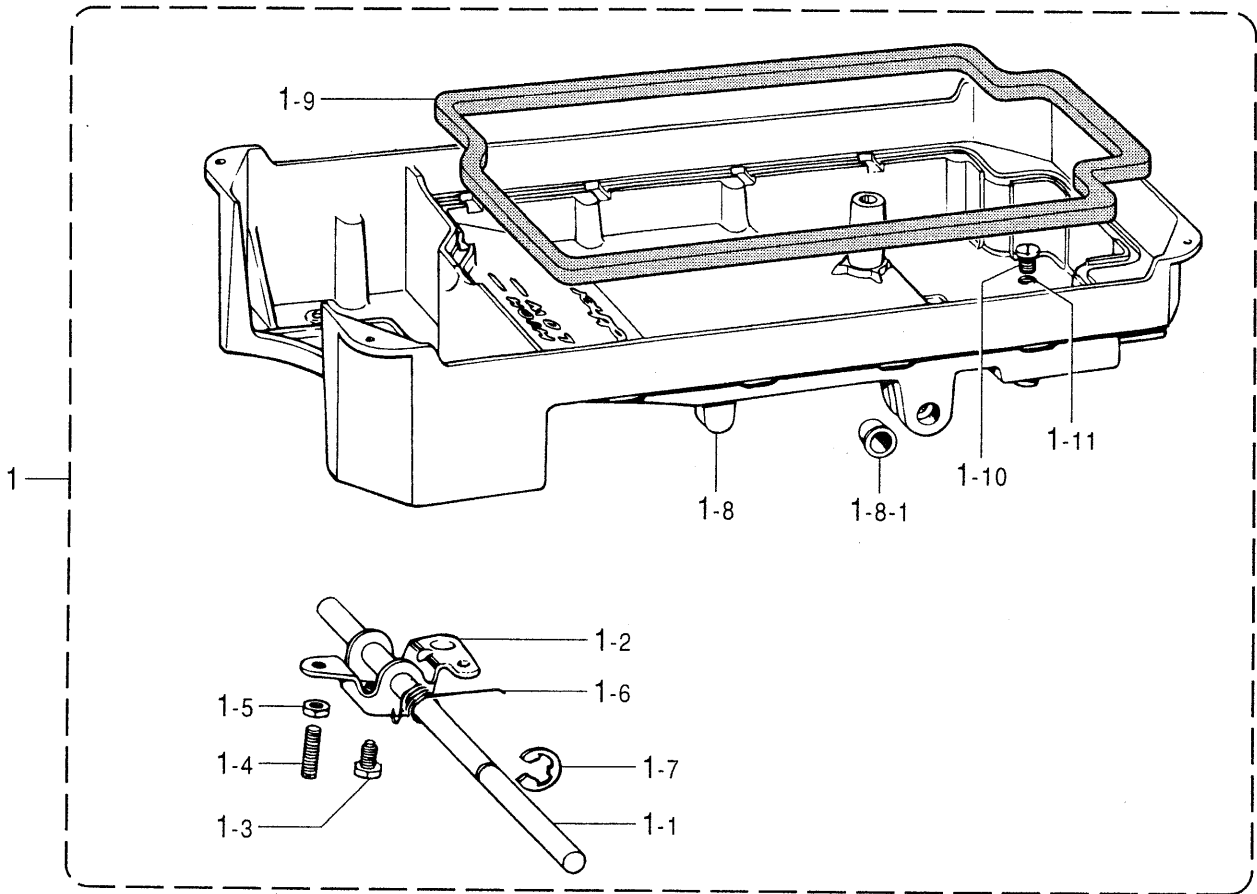

J2. 給油潤滑関係 / Lubrication

REF.NO.	CODE	Q'TY	ヒンメイ	NAME OF PARTS	RM
			<7210, 7230 用> <7220-10□,-30□,-40□用> <7240-10□,-30□,-40□用>	<For 7210, 7230> <For 7220-10□, -30□, -40□> <For 7240-10□, -30□, -40□>	
1	183496471	1	オイルパンクミ	OIL PAN ASSY	
1-1	146036101	1	ヒザアゲヨコジク	KNEE LIFTER SHAFT	
1-2	S09635001	1	ヒザアゲ	KNEE LIFTER	
1-3	146367001	1	ボルト5.95	BOLT, SM5.95	
1-4	104885101	2	トメネジ5.95	SET SCREW, SM5.95	
1-5	100022004	2	ナツト5.95	NUT, SM5.95	
1-6	S15889001	1	ヒザアゲネジリバネ	SPRING, TWIST	
1-7	146293001	1	トメワE10	RETAINING RING, E10	
1-8	149580571	1	オイルパン	OIL PAN	
1-8-1	149578000	2	ヨコジクブツシュ	BUSH	
1-9	146040001	1	オイルパツキング	PACKING	
1-10	140518001	1	シメネジ7.94	SCREW, SM7.94X10	
1-11	081007070	1	OリングP7	O RING, P7	
			<7220-90□用> <7240-90□用>	<For 7220-90□> <For 7240-90□>	
2	183379301	1	オイルパンクミ	OIL PAN ASSY	
2-1	146036101	1	ヒザアゲヨコジク	KNEE LIFTER SHAFT	
2-2	S02595101	1	オサエアゲリンク	PRESSER FOOT LIFTER LINK	
2-3	146367001	1	ボルト5.95	BOLT, SM5.95	
2-4	S02596001	1	ネジリバネ	SPRING, TWIST	
2-5	146293001	1	トメワE10	RETAINING RING, E10	
2-6	149580571	1	オイルパン	OIL PAN	
2-6-1	149578000	2	ヨコジクブツシュ	BUSH	
2-7	146040001	1	オイルパツキング	PACKING	
2-8	140518001	1	シメネジ7.94	SCREW, SM7.94X10	
2-9	081007070	1	OリングP7	O RING, P7	

< 7230, 7240 >

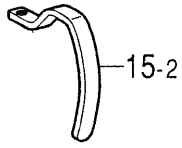

< 7210, 7230 >

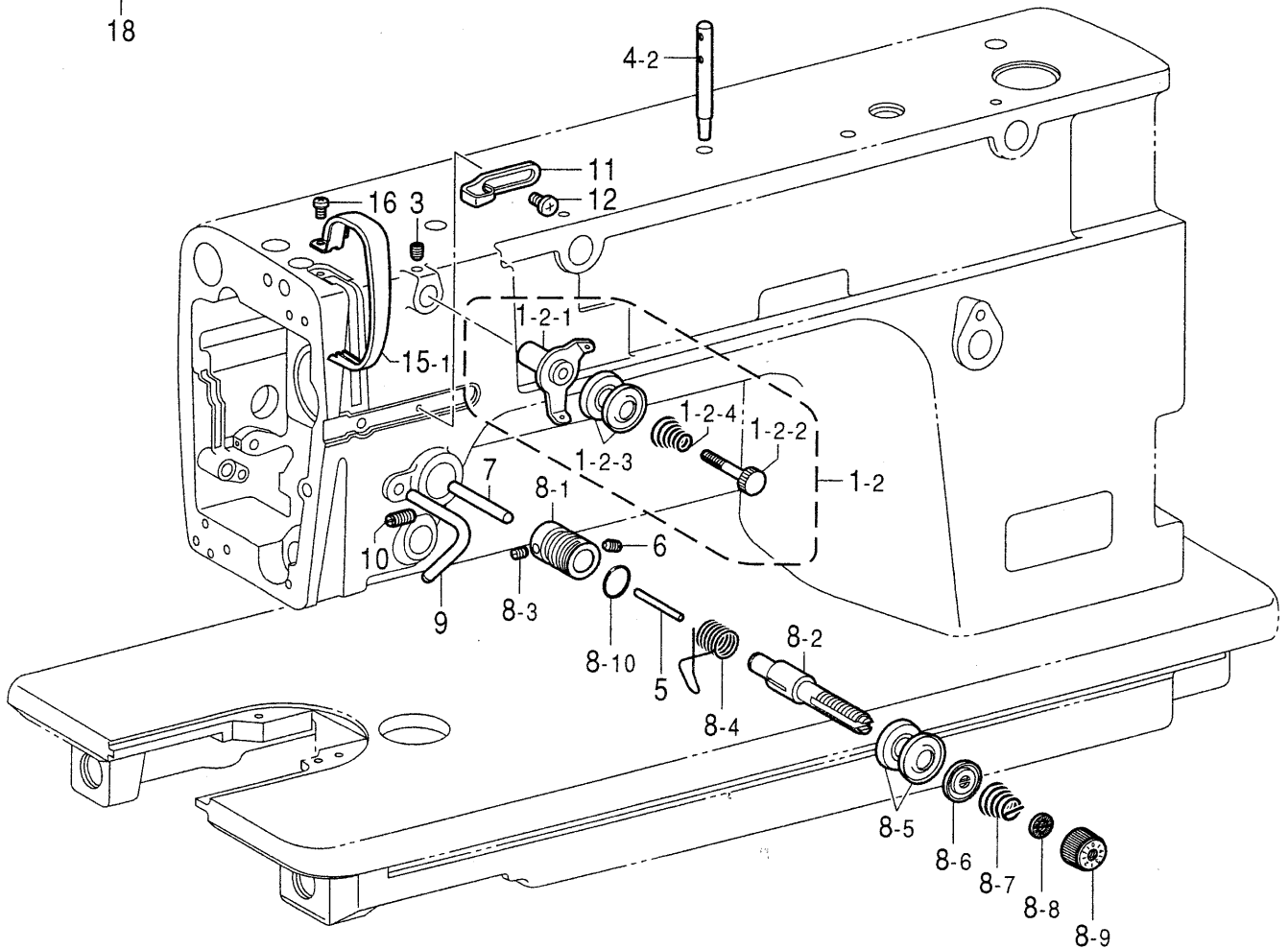
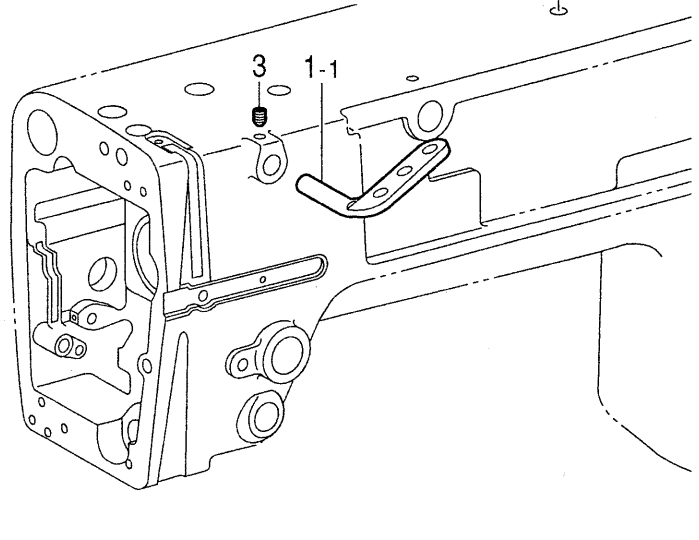
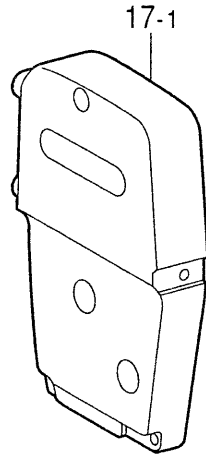
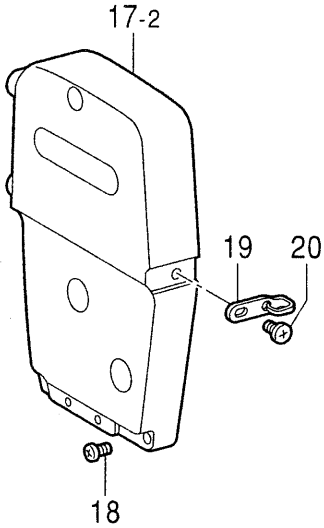
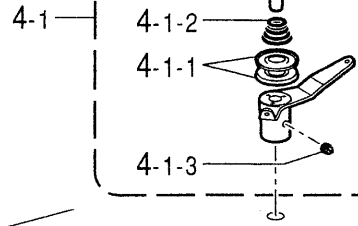

K. 糸通シ関係 / Threading mechanism

REF.NO.	CODE	Q'TY	ヒンメイ	NAME OF PARTS	RM
1-1	114931001	1	<7210, 7230 用> ミツメイトカケ	<For 7210, 7230> THREAD RETAINER	
1-2	183378001	1	<7220, 7240 用> プレテンションクミB	<For 7220, 7240> PRE-TENSION ASSY, B	
1-2-1	S02611001	1	イトアンナイ	THREAD GUIDE	
1-2-2	S02612001	1	イトアンナイチヨウシボウ	PRE-TENSION STUD	
1-2-3	144504001	2	イトアンナイサラ	DISC, THREAD GUIDE	
1-2-4	154562001	1	プレテンションバネB	SPRING, PRE-TENSION (B)	
3	014680622	1	アナトメネジ4.37クボミ	SET SCREW, SOCKET (CP) SM4.37	
4-1	144502001	1	<7210, 7230 用> プレテンションクミ	<For 7210, 7230> PRE-TENSION ASSY	
4-1-1	144504001	2	イトアンナイサラ	DISC, THREAD GUIDE	
4-1-2	144505000	1	イトアンナイバネ	SPRING	
4-1-3	102716004	1	トメネジ4.37	SET SCREW, SM4.37	
4-2	147557101	1	<7220, 7240 用> イトタテボウ	<For 7220, 7240> SPOOL PIN	
5	100400000	1	イトユルメピン	PIN	
5	S10437000	1	イトユルメピン	PIN	
5	S12699000	1	イトユルメピン	PIN	
5	150551000	1	イトユルメピン	PIN	
5	S01419000	1	イトユルメピン	PIN	
6	103950003	1	トメネジ5.95	SET SCREW, (CN) SM5.95	
7	S07972001	1	イトユルメボウ	TENSION RELEASE STUD	
8	S31031001	1	<7210-3, 7220-□03 用> イトチヨウシボウダイクミ	<For 7210-3, 7220-□03> THREAD TENSION BRACKET ASSY	
8-1	S03254001	1	イトチヨウシボウタイ	THREAD TENSION BRACKET	
8-2	116922001	1	イトチヨウシボウ	TENSION STUD	
8-3	100402004	1	トメネジ3.57	SET SCREW, SM3.57	
8-4	S02620001	1	イトトリバネ	SPRING	
8-5	145446001	2	イトチヨウシサラ	DISC, TENSION	
8-6	159805001	1	イトチヨウシサラオサエ	DISC PRESSER, TENSION	
8-7	104525001	1	イトチヨウシバネ	SPRING, TENSION	
8-8	S12441001	1	チヨウシバネウエザガネ	WASHER	
8-9	S31032001	1	イトチヨウシナツト	TENSION NUT	
8-10	114294001	1	Oリング	O RING	
8	S31034001	1	<7210-5, 7220-□05 用> <7230, 7240 用> イトチヨウシボウダイクミ	<For 7210-5, 7220-□05> <For 7230, 7240> THREAD TENSION BRACKET ASSY	
8-1	S03254001	1	イトチヨウシボウタイ	THREAD TENSION BRACKET	
8-2	116922001	1	イトチヨウシボウ	TENSION STUD	
8-3	100402004	1	トメネジ3.57	SET SCREW, SM3.57	
8-4	S02620001	1	イトトリバネ	SPRING	
8-5	145446001	2	イトチヨウシサラ	DISC, TENSION	
8-6	159805001	1	イトチヨウシサラオサエ	DISC PRESSER, TENSION	
8-7	S04632001	1	イトチヨウシバネ	TENSION SPRING	
8-8	S12441001	1	チヨウシバネウエザガネ	WASHER	
8-9	S31032001	1	イトチヨウシナツト	TENSION NUT	
8-10	114294001	1	Oリング	O RING	
9	116112001	1	イトアンナイ	THREAD GUIDE	

< 7230, 7240 >

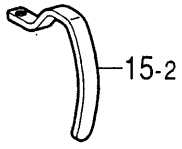

< 7210, 7230 >

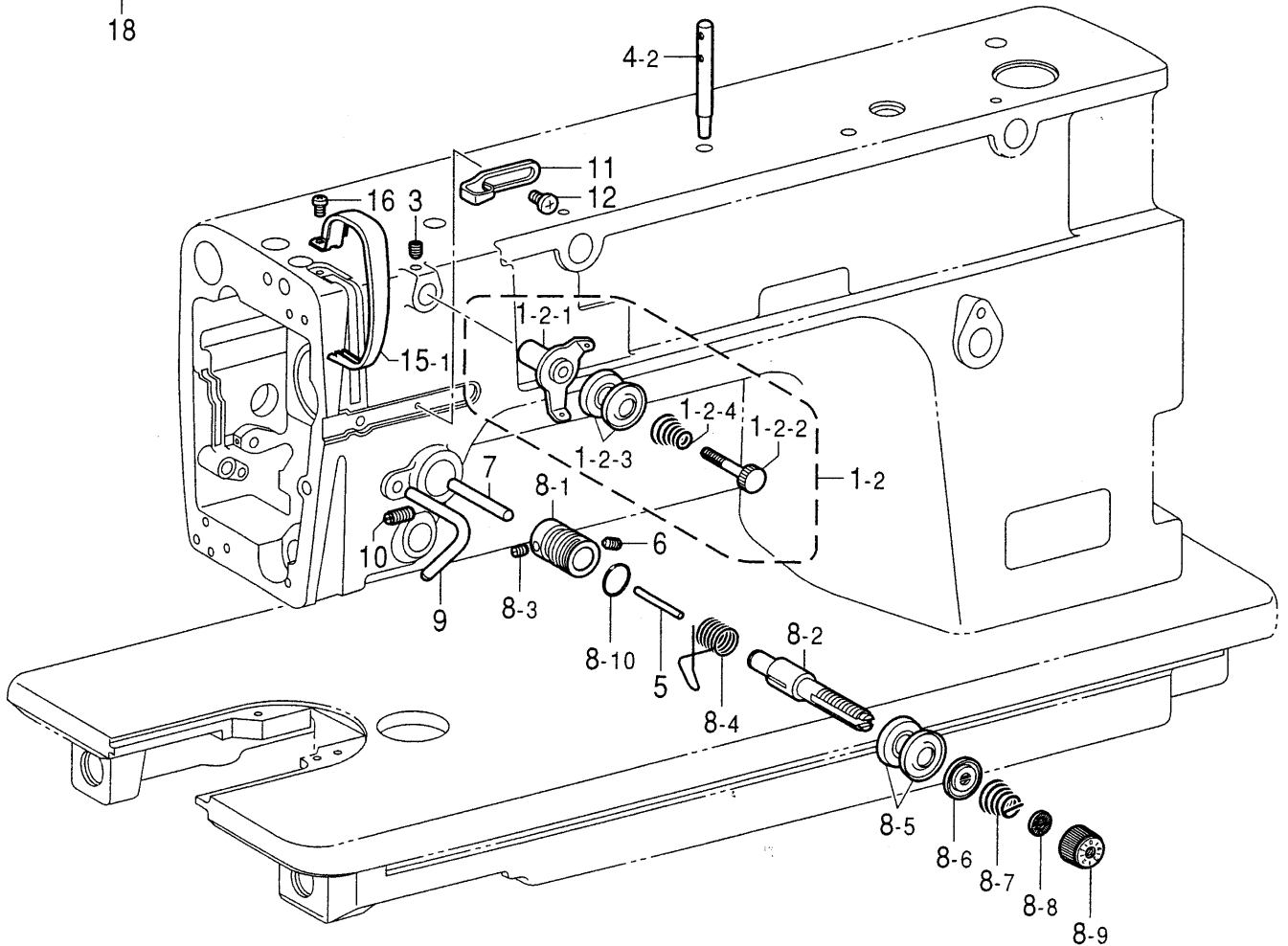
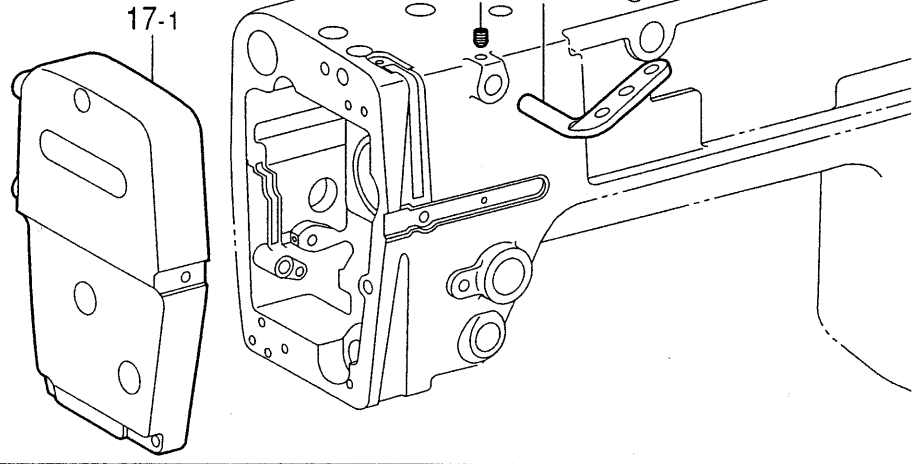
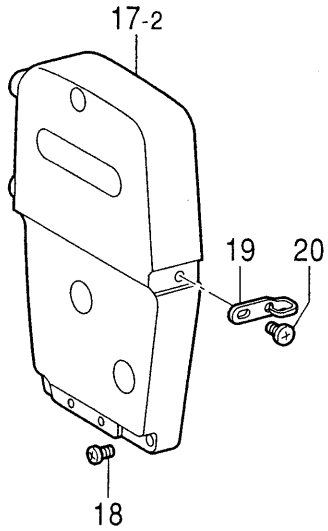
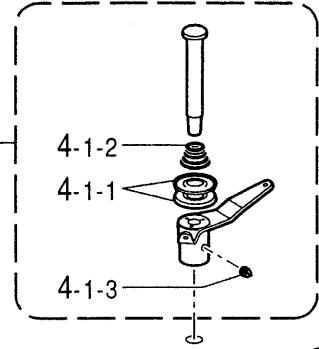

K. 糸通シ関係 / Threading mechanism

REF.NO.	CODE	Q'TY	ヒンメイ	NAME OF PARTS	RM
10	153483001	1	トメネジ4.76	SET SCREW, SM4.76	
11	145522101	1	アームイトアンナイR	ARM THREAD GUIDE, R	
12	S19056001	1	バインド357-40X6	SCREW, BIND SM3.57-40X6	
15-1	S02614124	1	<7210, 7220 用> テンビンカバー	<For 7210, 7220> THREAD TAKE-UP COVER	
15-2	147338109	1	<7230, 7240 用> テンビンカバー	<For 7230, 7240> THREAD TAKE-UP COVER	
16	062680812	1	ナベコ437-40X8	SCREW, PAN SM4.37-40X8	
17-1	S45801109	1	<7210, 7230 用> メンイタ	<For 7210, 7230> FACE PLATE	
17-2	S45857109	1	<7220, 7240 用> メンイタ	<For 7220, 7240> FACE PLATE	
18	062672012	3	ナベコ357-40X20	SCREW, PAN SM3.57-40X20	
19	S02617001	1	メンイタイトアンナイ	THREAD GUIDE, FACE PLATE	
20	060670612	1	バインド357-40X6	SCREW, BIND SM3.57-40X6	

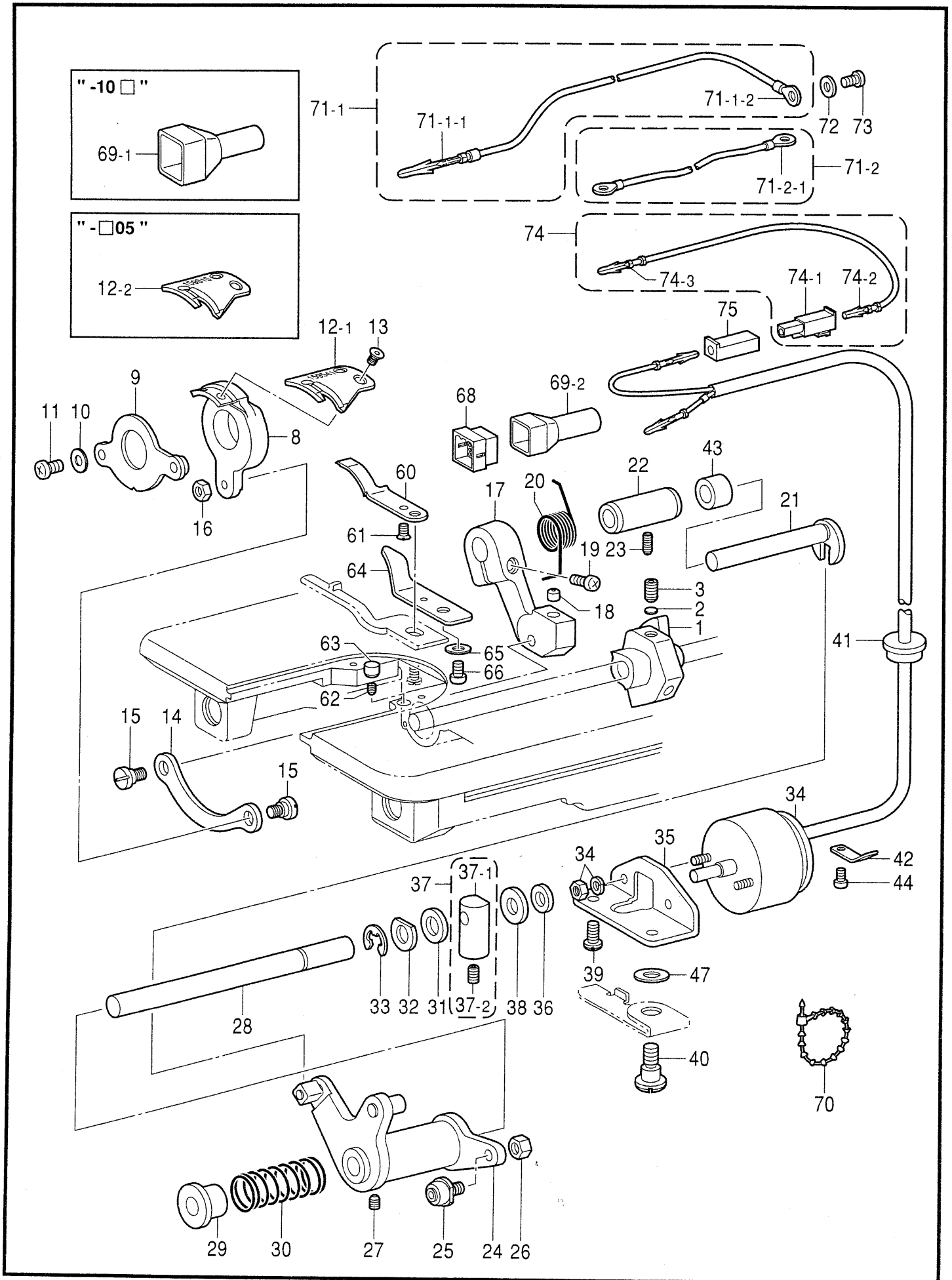

L1. 糸切り関係 (7220)/ Thread trimmer mechanism (7220)

REF.NO.	CODE	Q'TY	ヒンメイ	NAME OF PARTS	RM
1	154566021	1	イトキリカム	THREAD TRIMMER CAM	
2	154567000	2	カンザ5.3	SPACER, 5.3	
3	014771022	2	アナトメネジ6.35クボミ	SET SCREW, SOCKET (CP) SM6.35	
8	154570001	1	イトキリホルダ	MOVABLE KNIFE HOLDER	
9	154571001	1	イトキリホルダオサエクミ	KNIFE HOLDER PRESSER ASSY	
10	100645003	2	ザガネ	WASHER	
11	062681212	2	ナベコ437-40X12	SCREW, PAN SM4.37-40X12	
12-1	159541001	1	<-□03用> イドウハ	<For "-□03"> MOVABLE KNIFE	
12-2	159915001	1	<-□05用> イドウハS	<For "-□05"> MOVABLE KNIFE, S	
13	148537101	2	サラネジ4.37	SCREW, FLAT (W/SOCKET) SM4.37	
14	154576003	1	イトキリレンカン	THREAD TRIMMER CONNECTING ROD	
15	151987002	2	ダンネジ4.37	SHOULDER, SCREW SM4.37	
16	102571003	1	ナツト4.37	NUT, SM4.37	
17	159542201	1	イトキリレバー	THREAD TRIMMER LEVER	
18	S25437000	1	レバーストツバ	STOPPER, LEVER	
19	062711412	1	ナベコ4.76-32X14	SCREW, PAN SM4.76-32X14	
20	156623001	1	イトキリレバーバネ	SPRING	
21	S02647001	1	フタマタジク	FORKED SHAFT	
22	154581001	1	フタマタジクメタル	BUSH, FORKED SHAFT	
23	151607001	1	トメネジ4.37	SET SCREW, SM4.37	
24	154582021	1	イトキリカムレバークミ	THREAD TRIMMER CAM LEVER ASSY	
25	154590001	1	コロジクCクミ	ROLLER SHAFT ASSY, C	
26	105234003	1	ナツト4.37	NUT, SM4.37	
27	014770622	1	アナトメネジ6.35クボミ	SET SCREW, SOCKET (CP) SM6.35	
28	154593201	1	イトキリカムレバークミ	THREAD TRIMMER CAM LEVER SHAFT	
29	154594000	1	カラー	COLLAR	
30	154595001	1	カムレバーモッドバネ	SPRING	
31	154596000	1	イトキリカムレバークツシヨン	CUSHION	
32	110367001	1	ザガネ	WASHER, PLAIN SPECIAL 8	
33	048060342	1	トメワE6	RETAINING RING, E6	
34	S02815009	1	<DCモータ用> イトキリソレノイド	<For "DC motor"> THREAD TRIMMER SOLENOID	
34	156626009	1	<エフカモータ用> -----	<For "EFKA motor"> THREAD TRIMMER SOLENOID	
34	S07818009	1	<エフカモータAC用> -----	<For "AC of EFKA motor"> THREAD TRIMMER SOLENOID	
35	154598001	1	イトキリソレノイドダイ	THR. TRIMMER SOLENOID BRACKET	
36	154599000	1	ソレノイドクツシヨン	CUSHION, SOLENOID	
37	S23836001	1	ソレノイドレバークミ	SOLENOID LEVER ASSY	
37-1	S02654001	1	ソレノイドレバー	SOLENOID LEVER	
37-2	014680622	1	アナトメネジ4.37クボミ	SET SCREW, SOCKET (CP) SM4.37	
38	S02652001	1	ザガネ	WASHER	
39	110201001	1	シメネジ6.35	SCREW, SM6.35	
40	S02655002	1	ダンネジ6.35	SHOULDER SCREW, SM6.35	
41	157984009	1	コードブシュ	CORD BUSH	
42	S02657101	1	コードオサエ	CORD HOLDER	
43	S02648001	1	カラー	COLLAR	
44	062670812	1	ナベコ3.57-40X8	SCREW, PAN SM3.57-40X8	
47	155559001	1	ヒラザガネ	WASHER, PLAIN	

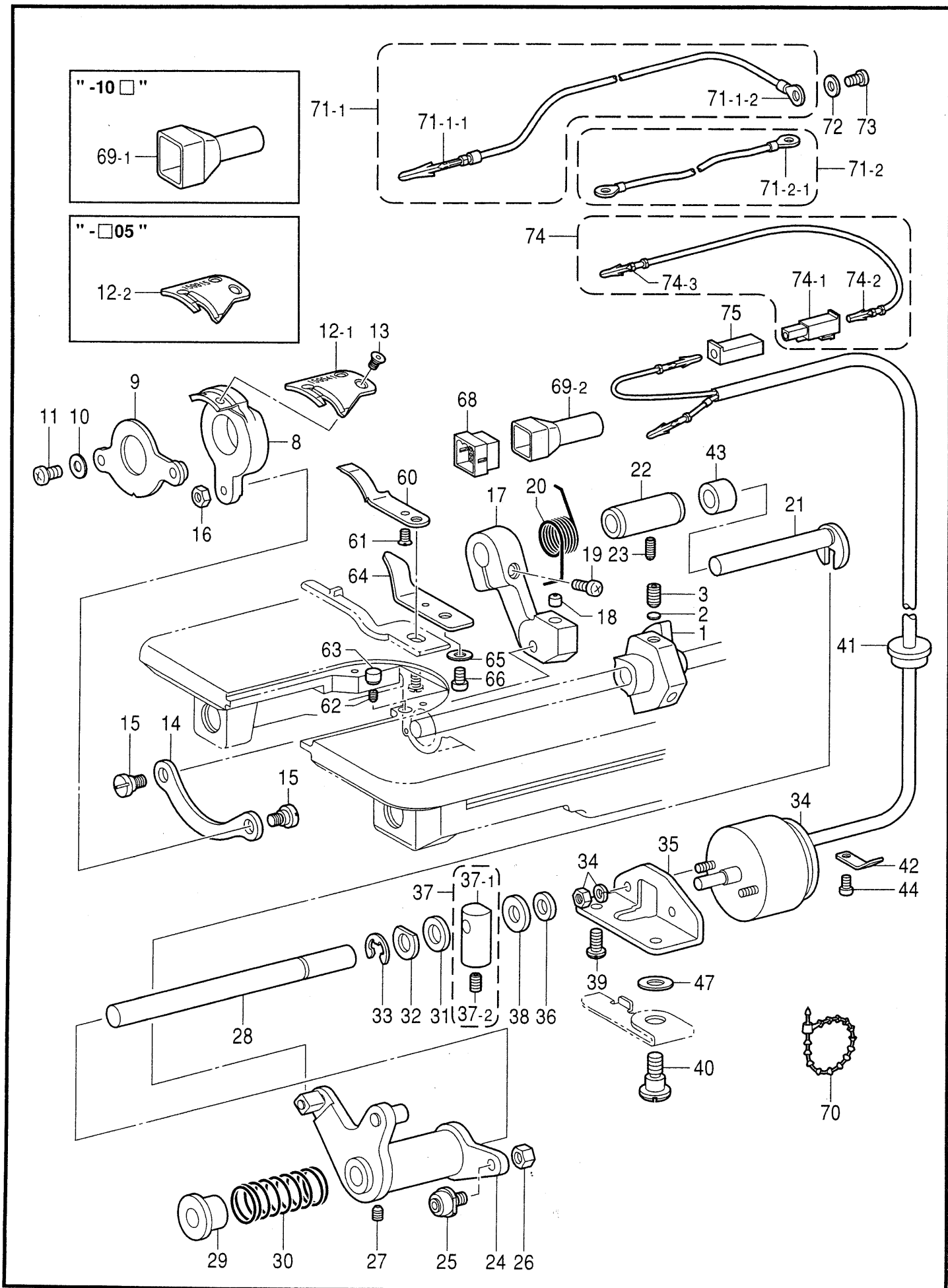

L1. 糸切り関係 (7220)/ Thread trimmer mechanism (7220)

REF.NO.	CODE	Q'TY	ヒンメイ	NAME OF PARTS	RM
60	S45900001	1	コテイハ	FIXED KNIFE	
61	102843004	1	サラネジ3.57	SCREW, FLAT SM3.57	
62	013660612	1	トメネジ3.18クボミ	SET SCREW, (CP) SM3.18	
63	142274009	1	ゴムセン4.2	RUBBER CAP, 4.2	
64	154569001	1	イトサバキ	LOWER THREAD FINGER	
65	100645003	1	ザガネ	WASHER	
66	062680812	1	ナベコ437-40X8	SCREW, PAN SM4.37-40X8	
68	153969000	1	ナイロンコネクタ12P	NYLON CONNECTOR, 12P	
<hr/>					
69-1	153970001	1	<-10□用> コネクタキヤツプ3	<For "-10□"> CONNECTOR CAP, 3	
69-2	S03815001	1	<-30□, -40□, -90□用> コネクタキヤツプ6	<For "-30□, -40□ & -90□"> CONNECTOR CAP, 6	
70	340400001	1	ユニタイバンド	BEAD BAND	
<hr/>					
71-1	S02682001	1	<DCモータ用> アースセンクミ	<For "DC motor"> GROUND WIRE ASSY	
71-1-1	S03328000	1	ピンターミナルオスL	TERMINAL PIN, L MALE	
71-1-2	204569001	1	アツタンシ4.5X14	TERMINAL, 4.5X14	
71-2	S06004001	1	<エフカモータ用> -----	<For "EFKA motor"> GROUND WIRE ASSY	
71-2-1	204569001	2	-----	TERMINAL, 4.5X14	
<hr/>					
72	S02745001	1	ザガネ	WASHER	
73	062680663	1	ナベコ437-40X6	SCREW, PAN SM4.37-40X6	
<hr/>					
74	S11210000	1	<DCモータ用> WコードSクミ	<For "DC motor"> W-CORD ASSY, S	
74-1	S11684000	1	コネクタ3191-01R1	CONNECTOR, 3191-01R1	
74-2	143548000	1	ピンターミナルメス	TERMINAL PIN, FEMALE	
74-3	143549000	1	ピンターミナルオス	TERMINAL PIN, MALE	
75	S11683000	1	コネクタ3191-01P1	CONNECTOR, 3191-01P1	

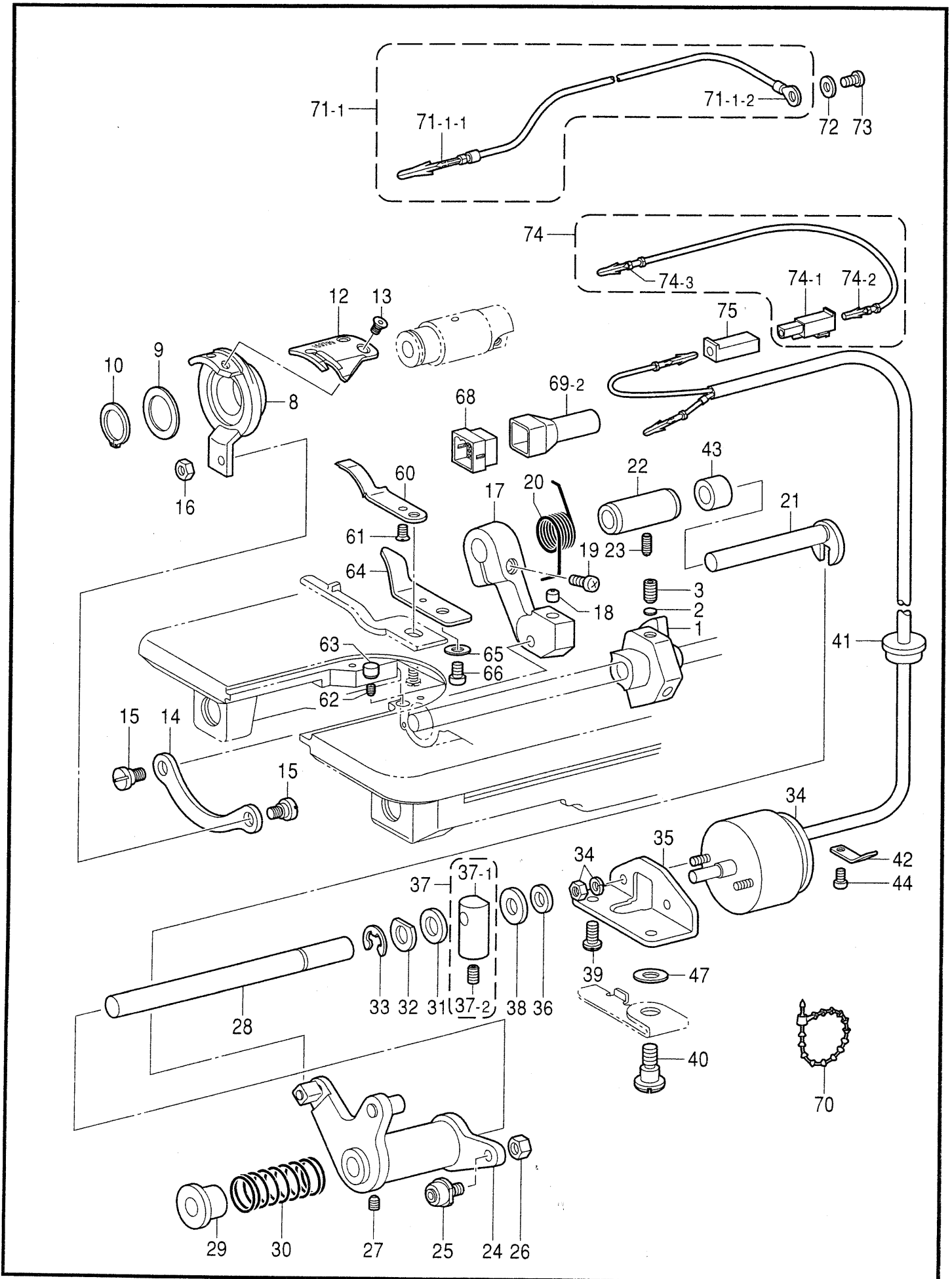

L2. 糸切り関係 (7240)/ Thread trimmer mechanism (7240)

REF.NO.	CODE	Q'TY	ヒンメイ	NAME OF PARTS	RM
1	154566021	1	イトキリカム	THREAD TRIMMER CAM	
2	154567000	2	カンザ5.3	SPACER, 5.3	
3	014771022	2	アナトメネジ6.35クボミ	SET SCREW, SOCKET (CP) SM6.35	
8	S45899001	1	イトキリホルダ	MOVEABLE KNIFE HOLDER	
9	156620000	1	スラストザガネ	WASHER, THRUST	
10	048180142	1	トメワジクヨウC18	RETAINING RING, EXTERNAL C18	
12	159799001	1	イドウハ	MOVABLE KNIFE	
13	148537101	2	サラネジ4.37	SCREW, FLAT (W/SOCKET) SM4.37	
14	154576003	1	イトキリレンカン	THREAD TRIMMER CONNECTING ROD	
15	151987002	2	ダンネジ4.37	SHOULDER, SCREW SM4.37	
16	102571003	1	ナツト4.37	NUT, SM4.37	
17	159800001	1	イトキリレバー	THREAD TRIMMER LEVER	
18	S25437000	1	レバーストツバ	STOPPER, LEVER	
19	062711412	1	ナベコ4.76-32X14	SCREW, PAN SM4.76-32X14	
20	154579001	1	イトキリレバーバネ	SPRING	
21	S02647001	1	フタマタジク	FORKED SHAFT	
22	154581001	1	フタマタジクメタル	BUSH, FORKED SHAFT	
23	151607001	1	トメネジ4.37	SET SCREW, SM4.37	
24	154582021	1	イトキリカムレバークミ	THREAD TRIMMER CAM LEVER ASSY	
25	154590001	1	コロジクCクミ	ROLLER SHAFT ASSY, C	
26	105234003	1	ナツト4.37	NUT, SM4.37	
27	014770622	1	アナトメネジ6.35クボミ	SET SCREW, SOCKET (CP) SM6.35	
28	154593201	1	イトキリカムレバークミ	THREAD TRIMMER CAM LEVER SHAFT	
29	154594000	1	カラー	COLLAR	
30	154595001	1	カムレバーモドシバネ	SPRING	
31	154596000	1	イトキリカムレバークツシヨン	CUSHION	
32	110367001	1	ザガネ	WASHER, PLAIN SPECIAL 8	
33	048060342	1	トメワE6	RETAINING RING, E6	
34	S02815009	1	イトキリソレノイド	THREAD TRIMMER SOLENOID	
35	154598001	1	イトキリソレノイドダイ	THR. TRIMMER SOLENOID BRACKET	
36	154599000	1	ソレノイドクツシヨン	CUSHION, SOLENOID	
37	S23836001	1	ソレノイドレバークミ	SOLENOID LEVER ASSY	
37-1	S02654001	1	ソレノイドレバー	SOLENOID LEVER	
37-2	014680622	1	アナトメネジ4.37クボミ	SET SCREW, SOCKET (CP) SM4.37	
38	S02652001	1	ザガネ	WASHER	
39	110201001	1	シメネジ6.35	SCREW, SM6.35	
40	S02655002	1	ダンネジ6.35	SHOULDER SCREW, SM6.35	
41	157984009	1	<-30□, -40□, -90□用> コードブシユ	<For "-30□, -40□ & -90□"> CORD BUSH	
42	S02657101	1	コードオサエ	CORD HOLDER	
43	S02648001	1	カラー	COLLAR	
44	062670812	1	ナベコ3.57-40X8	SCREW, PAN SM3.57-40X8	
47	155559001	1	ヒラザガネ	WASHER, PLAIN	
60	S45900001	1	コテイハ	FIXED KNIFE	
61	102843004	1	サラネジ3.57	SCREW, FLAT SM3.57	
62	013660612	1	トメネジ3.18クボミ	SET SCREW, (CP) SM3.18	
63	142274009	1	ゴムセン4.2	RUBBER CAP, 4.2	
64	S45671001	1	イトサバキ	THREAD RETAINER	
65	100645003	1	ザガネ	WASHER	
66	062680812	1	ナベコ437-40X8	SCREW, PAN SM4.37-40X8	
68	153969000	1	ナイロンコネクタ12P	NYLON CONNECTOR, 12P	
69-1	153970001	1	<-105用> コネクタキャツプ3	<For "-105"> CONNECTOR CAP, 3	

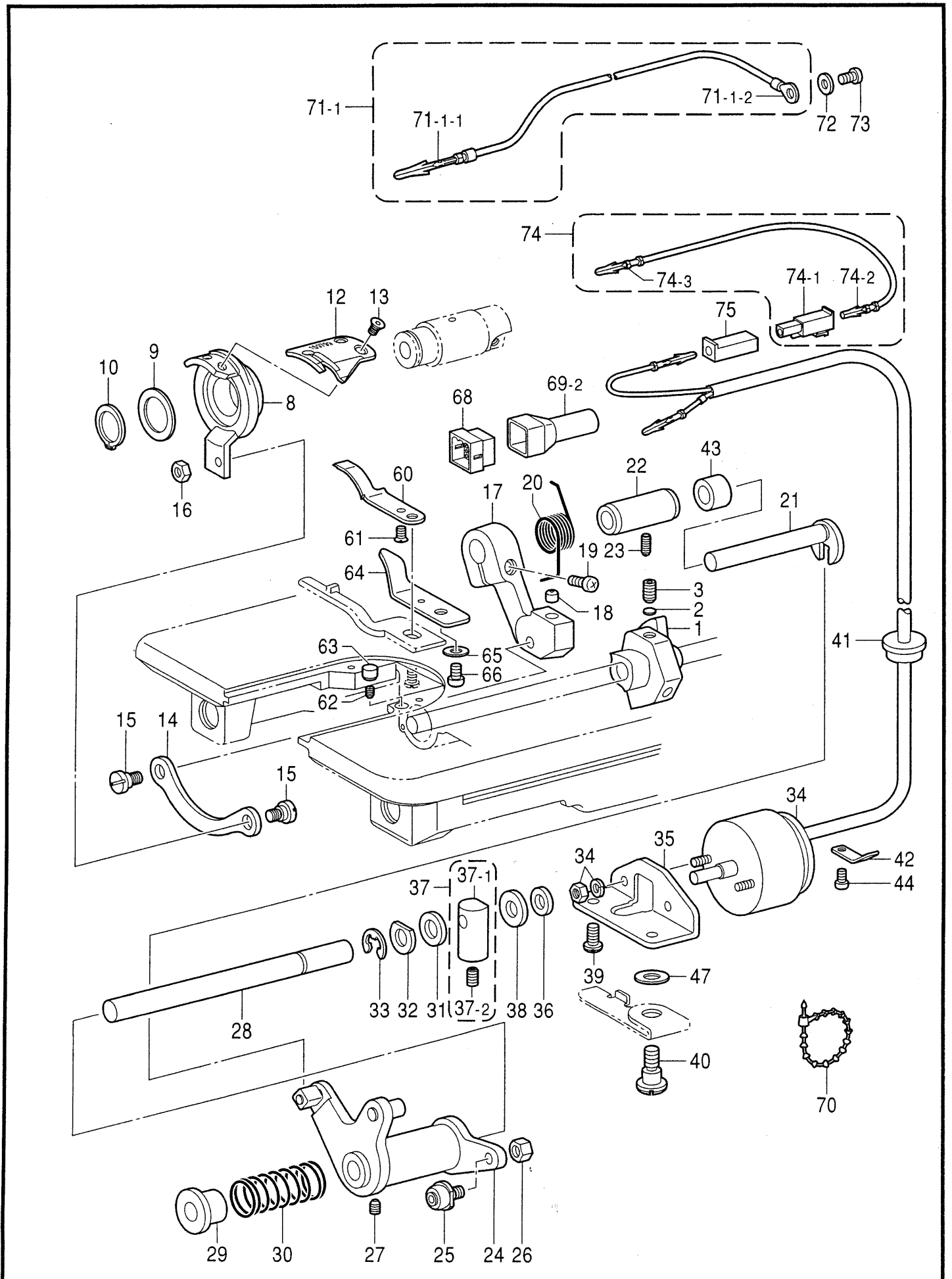

L2. 糸切り関係 (7240)/ Thread trimmer mechanism (7240)

REF.NO.	CODE	Q'TY	ヒンメイ	NAME OF PARTS	RM
69-2 70	S03815001 340400001	1 1	<-30□, -40□, -90□用> コネクタキャップ6 ユニタイバンド	<For "-30□, -40□ & -90□"> CONNECTOR CAP, 6 BEAD BAND	
71-1 71-1-1 71-1-2 72 73 74 74-1 74-2 74-3 75	S02682001 S03328000 204569001 S02745001 062680663 S11210000 S11684000 143548000 143549000 S11683000	1 1 1 1 1 1 1 1 1 1	アースセンクミ ピンターミナルオスL アツタンシ4.5X14 ザガネ ナベコ437-40X6 WコードSクミ コネクタ3191-01R1 ピンターミナルメス ピンターミナルオス コネクタ3191-01P1	GROUND WIRE ASSY TERMINAL PIN, L MALE TERMINAL, 4.5X14 WASHER SCREW, PAN SM4.37-40X6 W-CORD ASSY, S CONNECTOR, 3191-01R1 TERMINAL PIN, FEMALE TERMINAL PIN, MALE CONNECTOR, 3191-01P1	

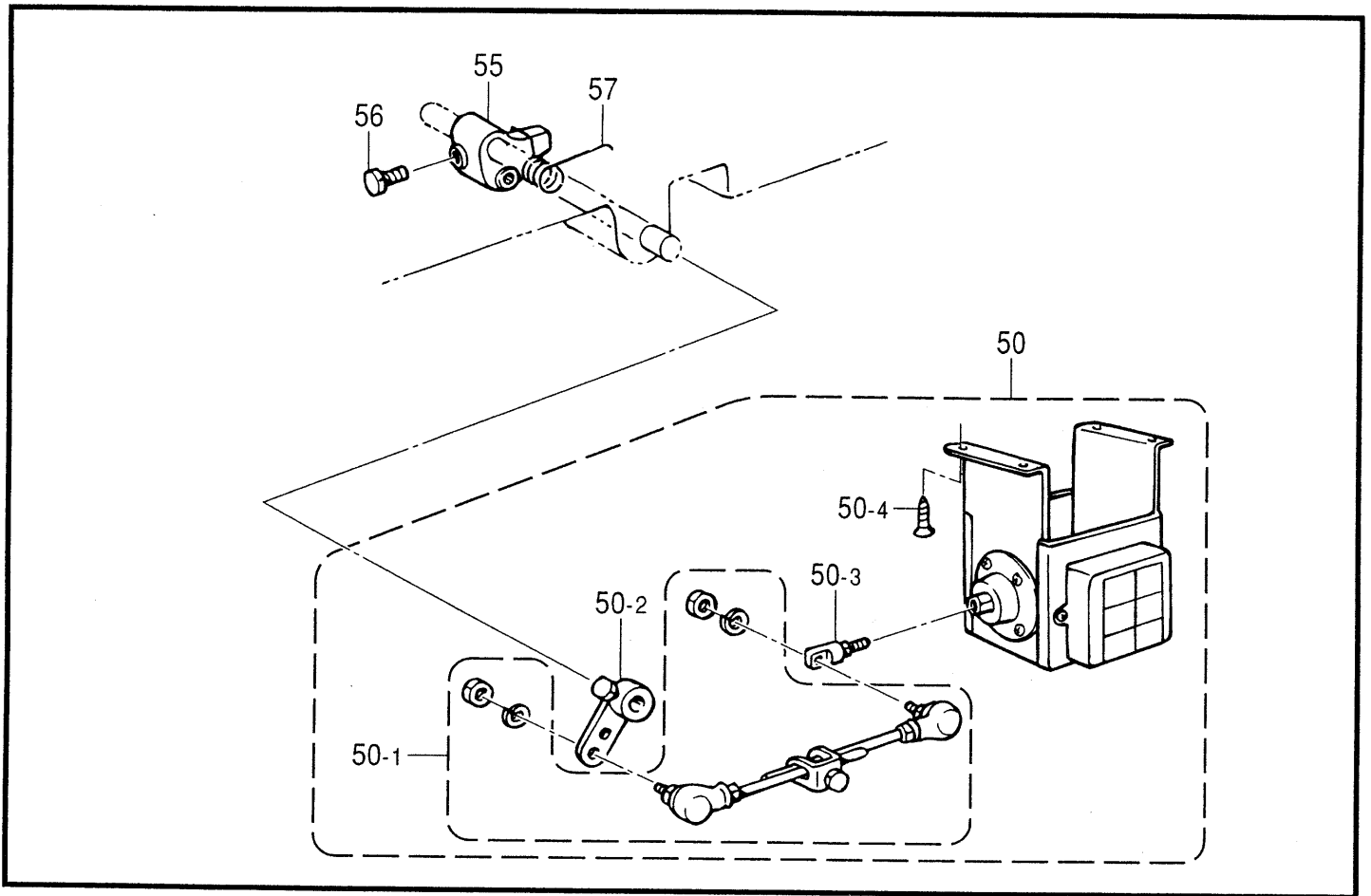

N. 糸暖メ関係 (7220, 7240) / Tension release mechanism (7220, 7240)

117-722-204

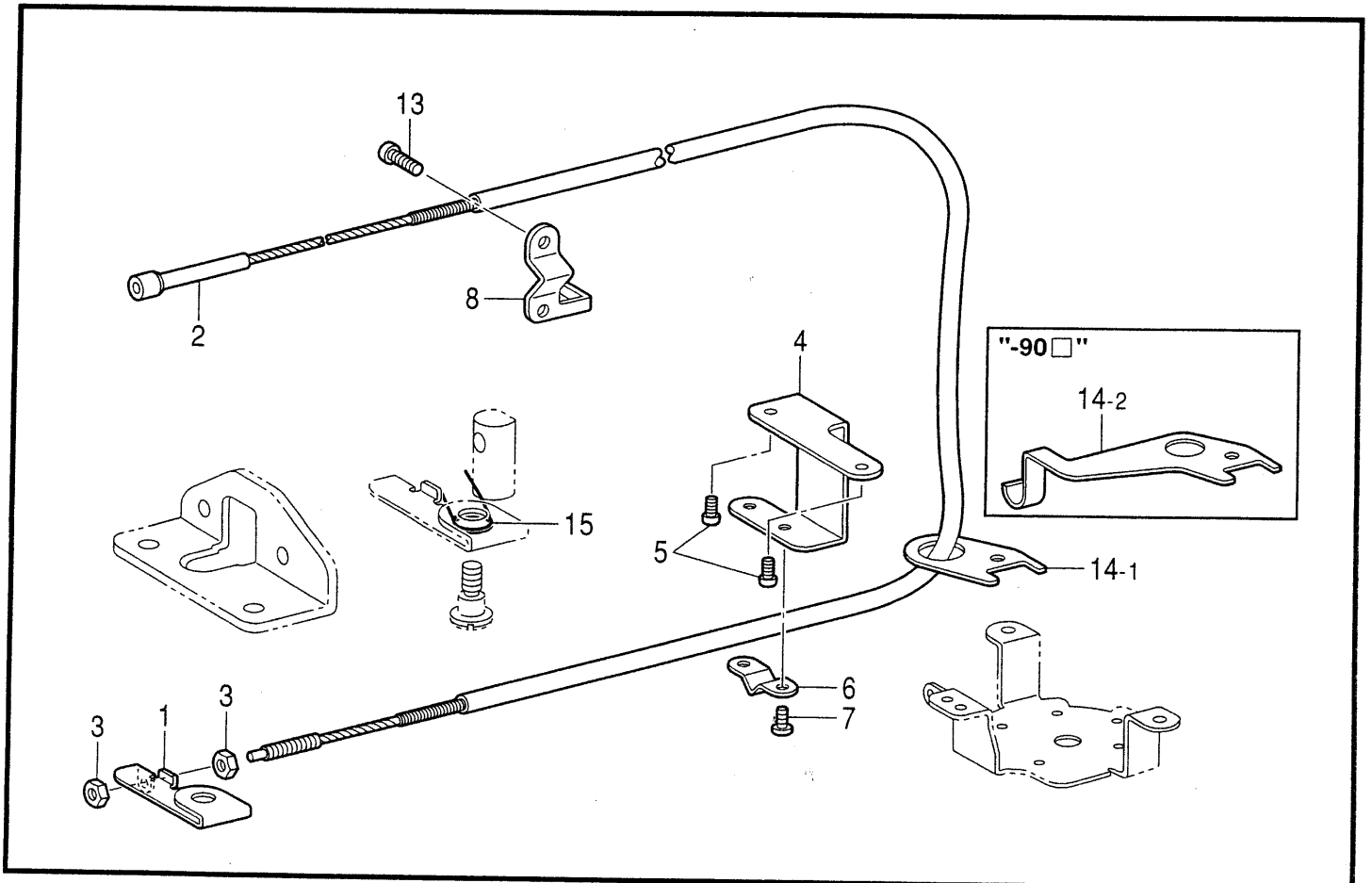

117-722-404

M. 押エ上げ関係 (7220, 7240: -90□)/

Presser foot lifter mechanism (7220, 7240: -90□)

REF.NO.	CODE	Q'TY	ヒンメイ	NAME OF PARTS	RM
			<-90□用>	<For use in Japanese>	
50	183961151	1	デンジオサエセットT	-----	
50-1	S42198051	1	オサエアゲロツドクミ	-----	
50-2	S42199051	1	オサエアゲレバークミ	-----	
50-3	S41955051	1	ロツドツギテクミ	-----	
50-4	S42200051	4	モクネジ	-----	
55	S02595101	1	オサエアゲリンク	-----	
56	146367001	1	ボルト5.95	-----	
57	S02596001	1	ネジリバネ	-----	

117-722-204

N. 糸緩メ関係 (7220, 7240)/ Tension release mechanism (7220, 7240)

REF.NO.	CODE	Q'TY	ヒンメイ	NAME OF PARTS	RM
1	S02658000	1	イトユルメレバー	TENSION RELEASE LEVER	
2	S02659101	1	イトユルメワイヤー	TENSION RELEASE WIRE	
3	110161004	2	ナツト4.76	NUT, SM4.76	
4	154606001	1	イトユルメワイヤーホルダD	WIRE HOLDER, D	
5	062670812	2	ナベコ3.57-40X8	SCREW, PAN SM3.57-40X8	
6	154607101	1	イトユルメワイヤーオサエD	WIRE HOLDER, D	
7	060670612	2	バインド357-40X6	SCREW, BIND SM3.57-40X6	
8	S02660101	1	イトユルメワイヤーオサエU	WIRE HOLDER, U	
9	S25375001	1	コードオサエT2	CORD HOLDER, T2	
10	062401416	1	ナベコ4X14	SCREW, PAN M4X14	
13	062672012	2	ナベコ357-40X20	SCREW, PAN SM3.57-40X20	
			<-90□用>	<For "-90□">	
14-1	157985001	1	イトユルメワイヤーアンナイ	WIRE GUIDE, T-RELEASE	
			<-10□, -30□, -40□用>	<For "-10□, -30□ & -40□">	
14-2	155347001	1	イトユルメワイヤーアンナイ	WIRE GUIDE, T-RELEASE	
15	S03670101	1	イトユルメモドシバネ	SPRING	

117-722-404

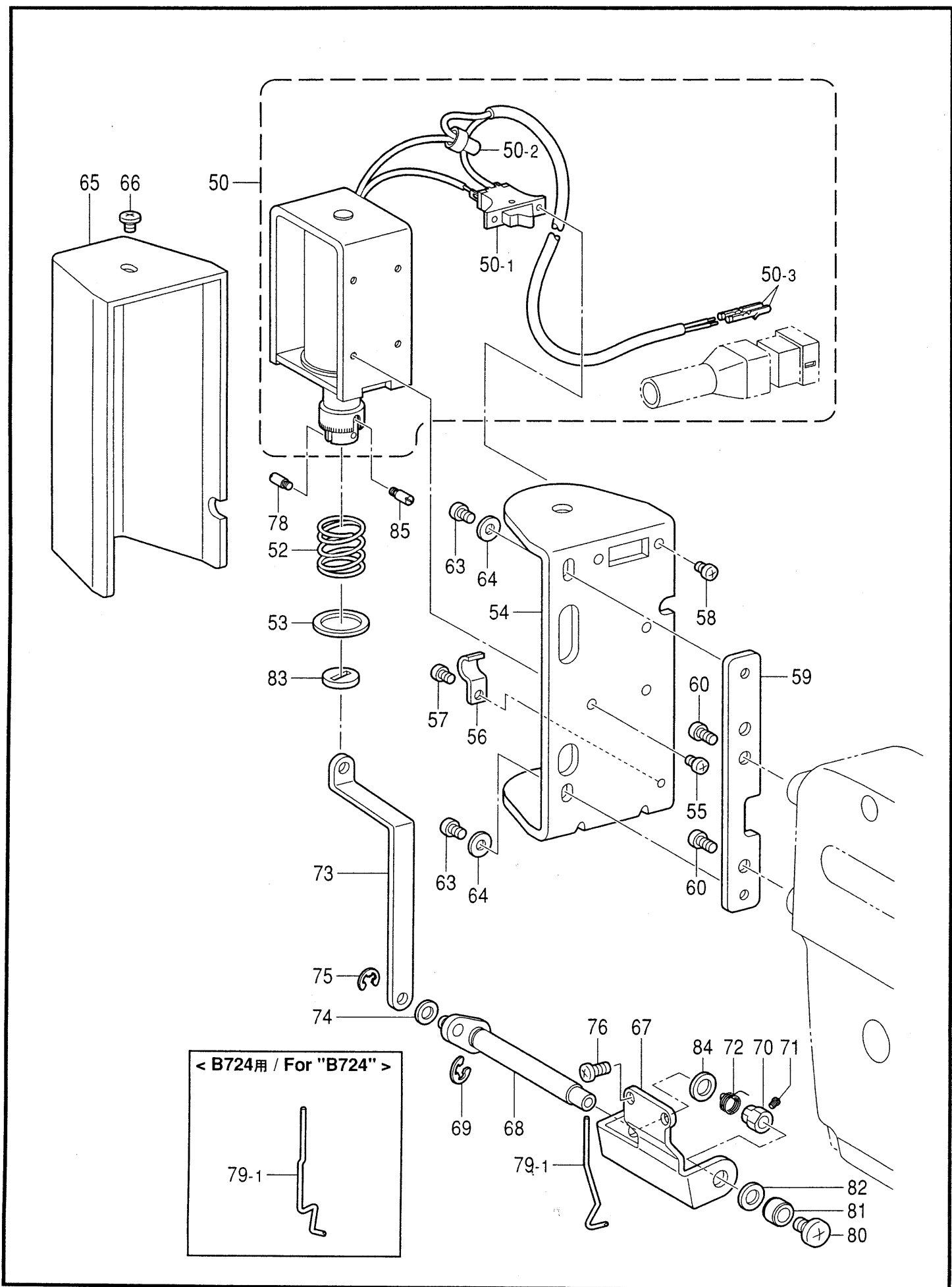

< B724用 / For "B724" >
 79-1

P. 糸払イ関係 (7220, 7240: -40□, -90□)/
 Thread wiper mechanism (7220, 7240: -40□, -90□)

REF.NO.	CODE	Q'TY	ヒンメイ	NAME OF PARTS	RM
			<DCモータ用>	<For "DC motor">	
50	S41202051	1	イトハライソレノイドクミ	THREAD WIPER SOLENOID ASSY	
50-1	S02664051	1	イトハライスイッチ	THREAD WIPER SWITCH	
50-2	S02665050	1	ヘイタンセツゾクシ	CONNECTOR	
50-3	143549050	2	ピンターミナルオス	TERMINAL PIN, MALE	
			<7220 エフカモータ用>	<For "EFKA motor of 7220">	
50	S42195051	1	-----	THREAD WIPER SOLENOID ASSY	
50-1	S02664051	1	-----	THREAD WIPER SWITCH	
50-2	S02665050	1	-----	CONNECTOR	
			<7220 エフカモータ AC 用>	<For "EFKA AC motor of 7220">	
50	S42196051	1	-----	THREAD WIPER SOLENOID ASSY	
50-1	S02664051	1	-----	THREAD WIPER SWITCH	
50-2	S02665050	1	-----	CONNECTOR	
50-3	143549050	2	-----	TERMINAL PIN, MALE	
52	S41206001	1	イトハライバネ	SPRING, THREAD WIPER	
53	S41205001	1	ヒラザガネ	WASHER, PLAIN	
54	S25449201	1	ソレノイドトリツケイタ	SETTING PLATE, SOLENOID	
55	062300616	3	ナベコM3X6	SCREW, PAN M3X6	
56	140647101	1	コードオサエ	CORD HOLDER	
57	062300616	1	ナベコM3X6	SCREW, PAN M3X6	
58	062300616	2	ナベコM3X6	SCREW, PAN M3X6	
59	S33609101	1	ソレノイドトリツケダイ	SETTING PLATE, SOLENOID	
60	062680812	2	ナベコ437-40X8	SCREW, PAN SM4.37-40X8	
63	062400616	2	ナベコM4X6	SCREW, PAN M4X6	
64	026040236	2	ヒラザガネミガキ4	WASHER, PLAIN 4	
65	S33610001	1	ソレノイドカバー	SOLENOID COVER	
66	060400516	1	バインドM4X5	SCREW, BIND M4X5	
67	S03299009	1	イトハライジクウケイタ	THREAD WIPER SHAFT PLATE	
68	S34123101	1	イトハライクランククミ	THREAD WIPER CRANK ASSY	
69	048040342	1	トメワE4	RETAINING RING, E4	
70	S25454001	1	セツトカラー	SET SCREW COLLAR	
71	S25279001	1	アタマトメクボミ M3.5-5	SET SCREW, (CP) M3.5-5	
72	S02678001	1	ワイパーバネ	SPRING	
73	S03302009	1	イトハライロツド	THREAD WIPER ROD	
74	110735002	1	ザガネ	WASHER	
75	048030342	1	トメワE3	RETAINING RING, E3	
76	062681012	2	ナベコ437-40X10	SCREW, PAN SM4.37-40X10	
78	S25456001	1	プランジャピン	PLUNGER PIN	
79	S45916000	1	イトハライ	THREAD WIPER	
80	060400516	1	バインドM4X5	SCREW, BIND M4X5	
81	146288001	1	イトハライジクカラー	COLLAR, THREAD WIPER STUD	
82	S03677001	1	ザガネ	WASHER	
83	S41207000	1	スパーサゴム	SPACER RUBBER	
84	149097000	1	シヨウオンシート	SILENT SHEET	
85	S25456001	2	プランジャピン	PLUNGER PIN	

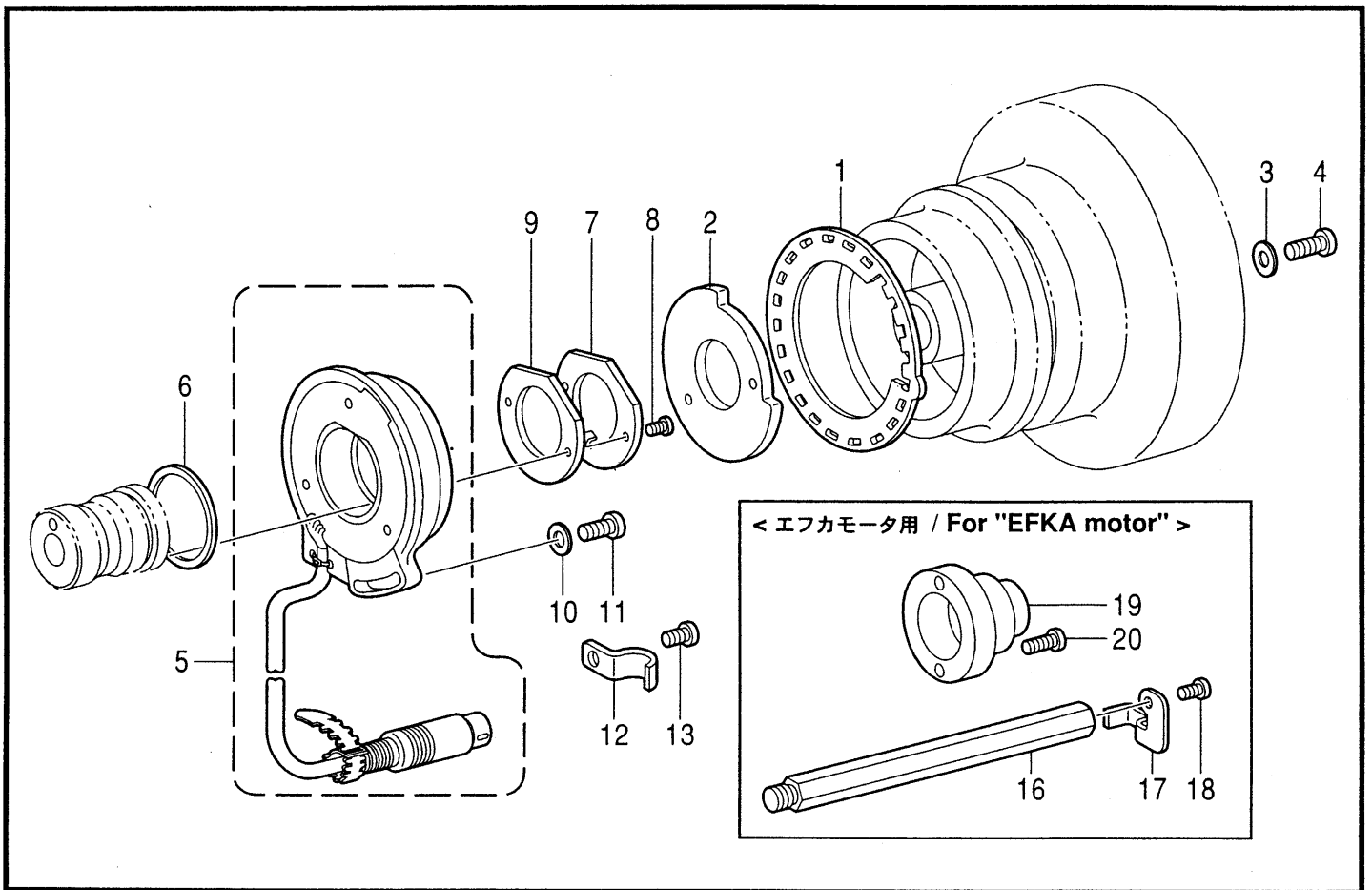

117-722-501

R. コントロールボックス関係 (7220, 7240) / Control box mechanism (7220, 7240)

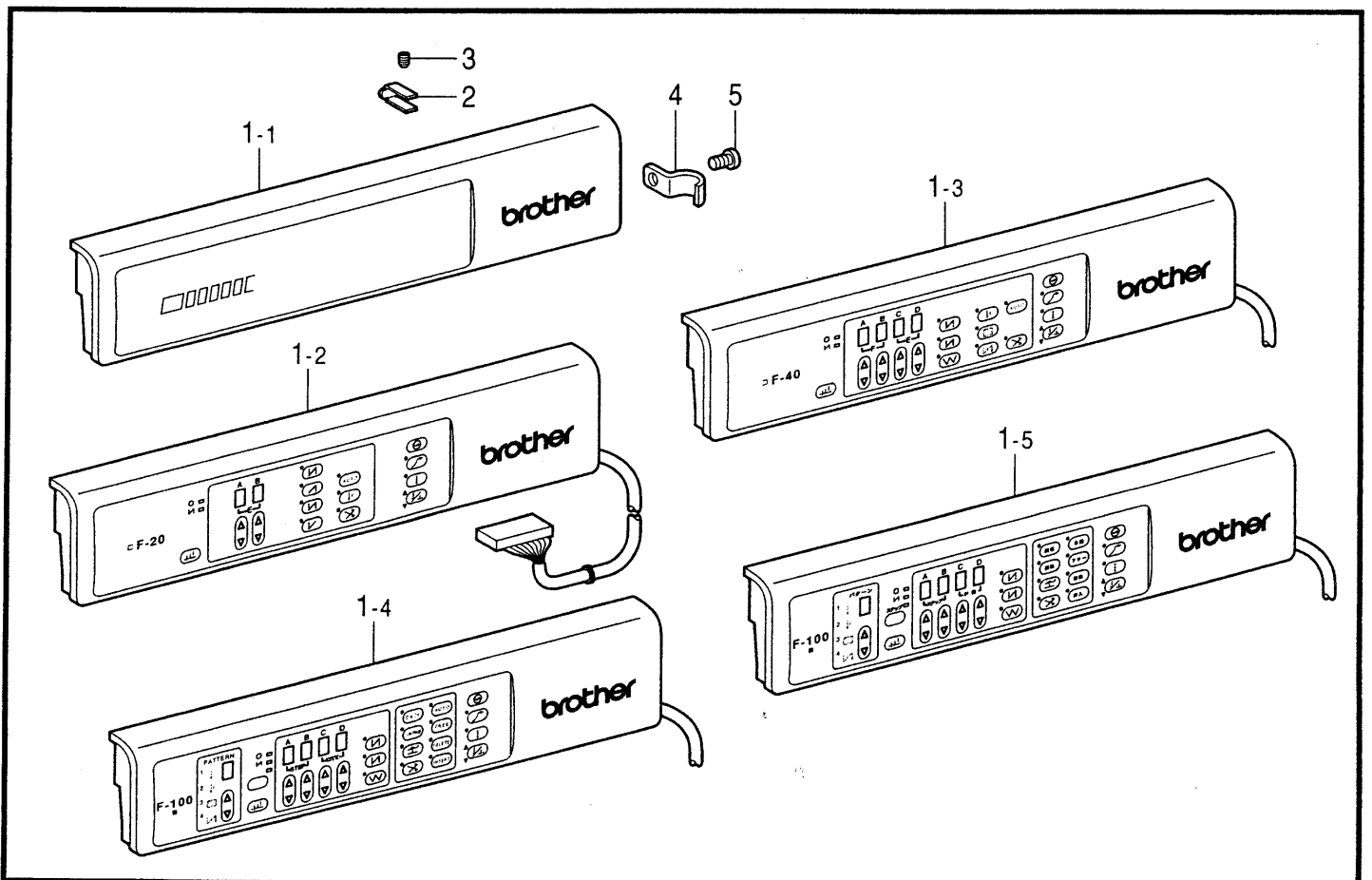

117-722-502

Q. 針位置検出器関係 (7220, 7240)/ Synchronizer (7220, 7240)

REF.NO.	CODE	Q'TY	ヒンメイ	NAME OF PARTS	RM
1	502684101	1	ソクドシレイイタ24	SPEED COMMAND PLATE, 24	
2	502685001	1	ハリウエイタ	PLATE, NEEDLE UPPER STOP	
3	100645003	2	ザガネ	WASHER	
4	062681612	2	ナベコ437-40X16	SCREW, PAN SM4.37-40X16	
5	291079001	1	シンクロナイザ#13ホキユ	SYNCHRONIZER, #13	
6	503327000	1	シンクロナイザパツキン	PACKING, SYNCHRONIZER	
7	502687201	1	ケンシュツキオサエ	SUPPORT, SYNCHRONIZER	
8	062630712	2	ナベコ238-56X7	SCREW, PAN SM2.38-56X7	
9	507885000	1	ケンシュツキオサエパツキン	SUPPORT PACKING, SYNCHRONIZER	
10	113431002	1	ザガネ	WASHER	
11	062711012	1	ナベコ476-32X10	SCREW, PAN SM4.76-32X10	
12	140647101	1	コードオサエ	CORD HOLDER	
13	062670612	1	ナベコ357-40X6	SCREW, PAN SM3.57-40X6	

			<7220 エフカモータ用>	<For "EFKA motor of 7220">	
16	159318001	1	-----	SYNCHRONIZER HOLDER BAR, S	
17	159319001	1	-----	SYNCHRONIZER HOLDER	
18	062670612	1	-----	SCREW, PAN SM3.57-40X6	
19	148825001	1	-----	SLIP RING JOINT	
20	062711412	2	-----	SCREW, PAN SM4.76-32X14	

117-722-501

R. コントロールボックス関係 (7220, 7240)/ Control box mechanism (7220, 7240)

REF.NO.	CODE	Q'TY	ヒンメイ	NAME OF PARTS	RM
1-1	S45895001	1	B F-0パネルクミTR	<For Export of 7220-10□> B-PANEL ASSY, B F-0 TR	

2	S34448001	2	パネルシジダイ	PANEL SUPPORT BRACKET	
3	014680622	2	アナトメネジ4.37クボミ	SET SCREW, SOCKET (CP) SM4.37	
4	157170101	1	コードホルダC	CORD HOLDER, C	
5	062680812	1	ナベコ437-40X8	SCREW, PAN SM4.37-40X8	

			" 補給用部品 "	" For Supply parts "	
1-2	J80751001	1	-----	BI-PANEL ASSY, B F-20	
1-3	J80750001	1	BIパネルBF40クミホキ	BI-PANEL ASSY, B F-40	
1-4	J80749001	1	BIパネルBF100コク	BI-PANEL ASSY, B F-100 ENG.	
1-5	J80754001	1	BIパネルBF100クミ	-----	

117-722-502

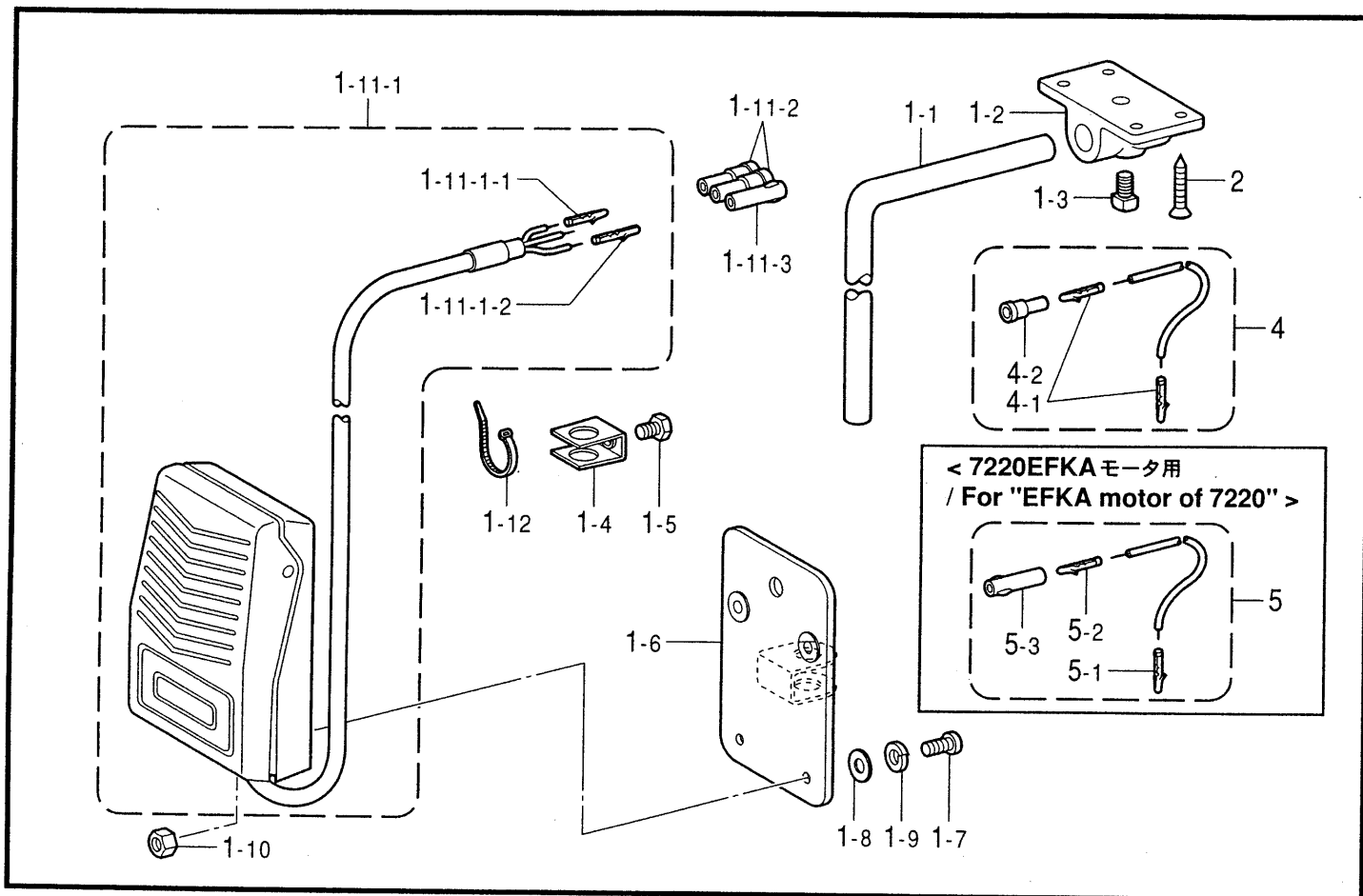

T. 逆転スイッチ関係 (7220, 7240) / Quick reverse switch mechanism (7220, 7240)

117-722-507

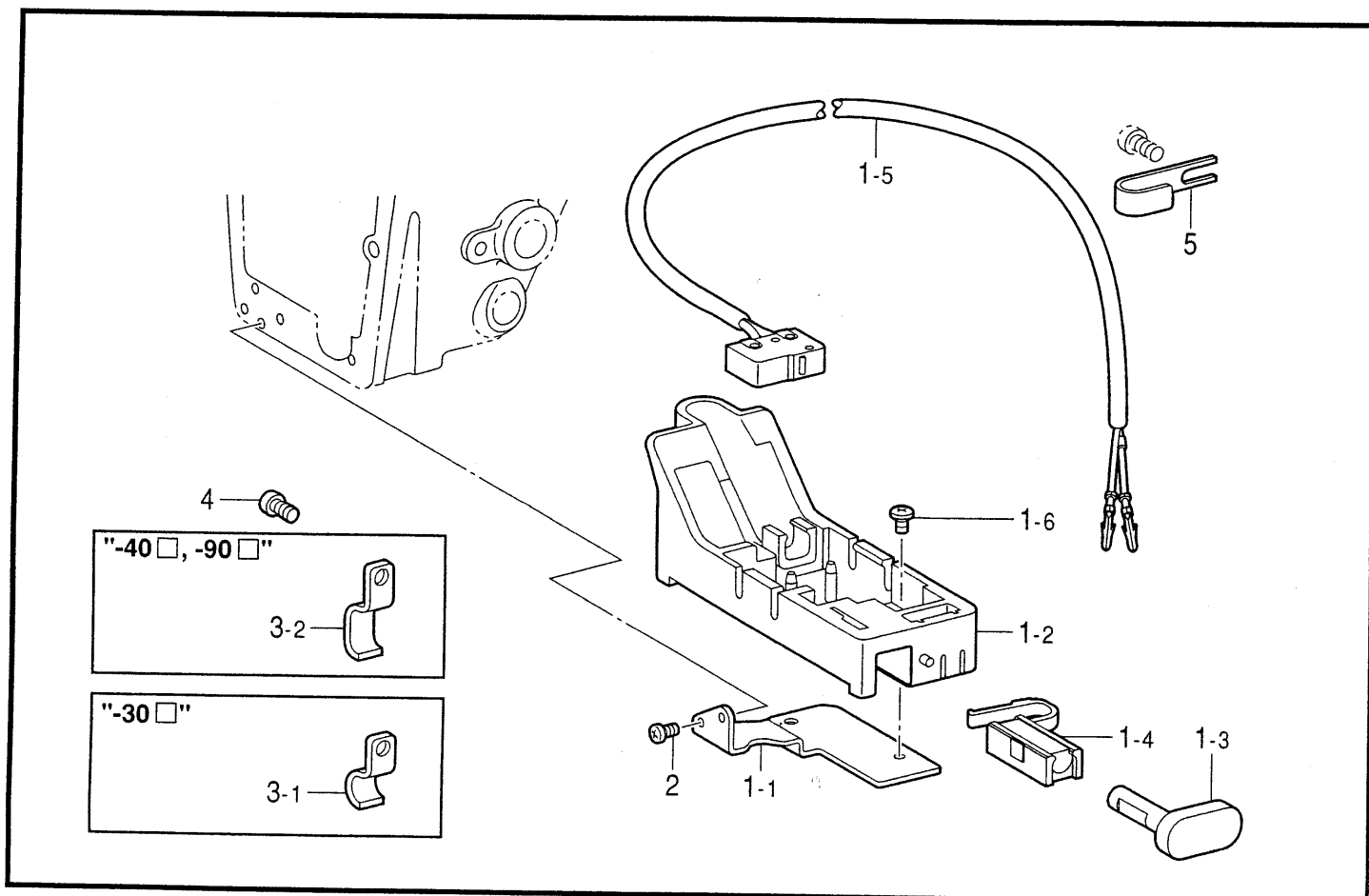

117-722-508

S. ヒザスイッチ関係 (7220, 7240: -90□)/

Knee switch mechanism (7220, 7240: -90□)

REF.NO.	CODE	Q'TY	ヒンメイ	NAME OF PARTS	RM
1	S07045009	1	ヒザスイッチクミ	KNEE SWITCH ASSY	
1-1	142026003	1	ヒザスイッチタテジク	KNEE SWITCH SHAFT	
1-2	142027001	1	ヒザスイッチタテジクウケ	KNEE SWITCH SHAFT BRACKET	
1-3	100463001	1	カクボルト7.94	BOLT, SQUARE SM7.94	
1-4	114967001	1	ヒザアテストツバ	STOPPER, K-LIFTER PLATE	
1-5	110087001	1	ボルト5.95	BOLT, SM5.95X8	
1-6	S07027001	1	ヒザスイッチトリツケイタ	SETTING PLATE, K-LIFTER SW	
1-7	062401006	4	ナベコ4X10	SCREW, PAN M4X10	
1-8	025040233	4	ヒラザガネチユウ4	WASHER, PLAIN M 4	
1-9	028040243	4	バネザガネ2-4	WASHER, SPRING 2-4	
1-10	021400164	4	ナット1シユ4	NUT, 1 M4	
1-11	S07030009	1	スイッチコードクミ	SWITCH & CORD ASSY	
1-11-1	S07031009	1	フツトスイッチクミ	FOOT SWITCH ASSY	
1-11-1-1	143549000	2	ピンターミナルオス	TERMINAL PIN, MALE	
1-11-1-2	143548000	1	ピンターミナルメス	TERMINAL PIN, FEMALE	
1-11-2	146046000	2	ナイロンコネクタ	NYLON CONNECTOR	
1-11-3	146194000	1	ナイロンコネクタ	NYLON CONNECTOR	
1-12	149799000	1	タイラツプS	BEAD BAND, S	
2	034422503	4	+サラモクネジ4.1X25	WOOD SCREW, FLAT M4.1X25	
4	S05981000	1	Bコード100クミ2	B-CORD ASSY, 100 (2)	
4-1	143549000	2	ピンターミナルオス	TERMINAL PIN, MALE	
4-2	146046000	1	ナイロンコネクタ	NYLON CONNECTOR	
5	S05982000	1	<7220 エフカモータ用>	<For "EFKA motor of 7220">	
5-1	143549000	1	-----	W-CORD ASSY, 100	
5-2	143548000	1	-----	TERMINAL PIN, MALE	
5-3	146194000	1	-----	TERMINAL PIN, FEMALE	
			-----	NYLON CONNECTOR	

117-722-507

T. 逆転スイッチ関係 (7220, 7240)/ Quick reverse switch mechanism (7220, 7240)

REF.NO.	CODE	Q'TY	ヒンメイ	NAME OF PARTS	RM
1	S45860001	1	<DCモータ用>	<For "DC motor">	
1-5	S32906000	1	Rアクチュエータークミ	REVERSE ACTUATOR ASSY	
			Rスイッチクミ	REVERSE SWITCH ASSY	
1	S45862001	1	<7220 エフカモータ用>	<For "EFKA motor of 7220">	
1-5	S32910000	1	-----	REVERSE ACTUATOR ASSY	
			-----	REVERSE SWITCH ASSY	
1	S45863001	1	<7220 エフカモータ AC用>	<For "EFKA motor AC of 7220">	
1-5	S32916000	1	-----	REVERSE ACTUATOR ASSY	
			-----	REVERSE SWITCH ASSY	
1-1	S45861001	1	<共通部品>	<Common parts>	
1-2	S32903000	1	Rスイッチササエ	REVERSE SWITCH SUPPORT	
1-3	S32904000	1	Rスイッチダイ	REVERSE SWITCH BRACKET	
1-4	S32905000	1	アクチュエーター	ACTUATOR	
1-5	S32906000	1	Rスイッチバネ	SPRING, REVERSE SWITCH	
1-6	060300606	1	Rスイッチクミ	REVERSE SWITCH ASSY	
			バインド3X6	SCREW, BIND M3X6	
2	062670612	2	ナベコ357-40X6	SCREW, PAN SM3.57-40X6	
3-1	140647101	2	<-30□用>	<For "-30□">	
			コードオサエ	CORD HOLDER	
3-2	S07327001	2	<-40□, -90□用>	<For "-40□ & -90□">	
			コードオサエL	CORD HOLDER, L	
4	062670612	2	ナベコ357-40X6	SCREW, PAN SM3.57-40X6	
5	S02704001	1	コードオサエ	CORD HOLDER	

117-722-508

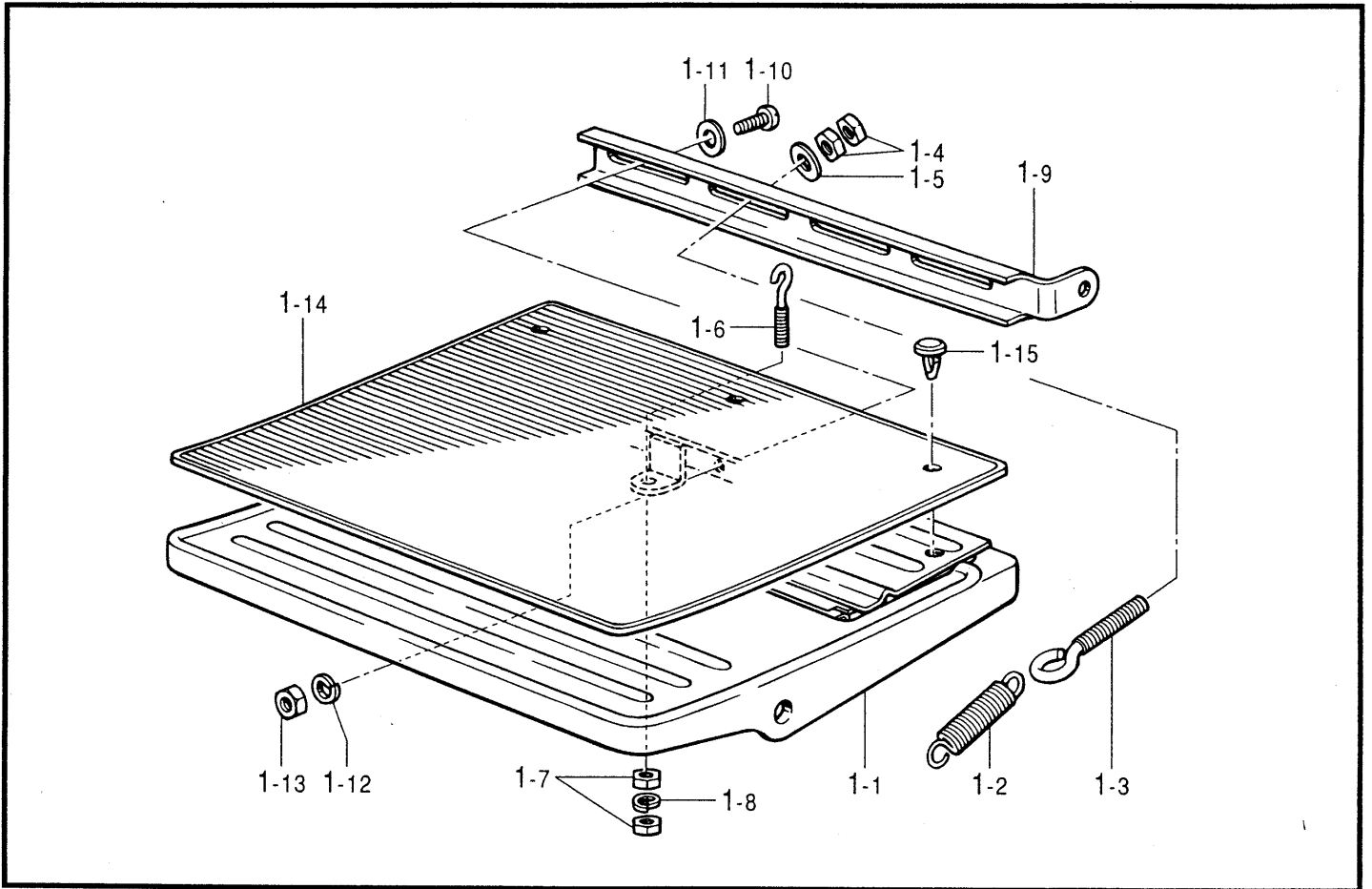

V1 . 電磁押工上げ関係 (7220, 7240 輸出用) / Presser foot lifting solenoid set (7220, 7240: -90□) 117-722-651

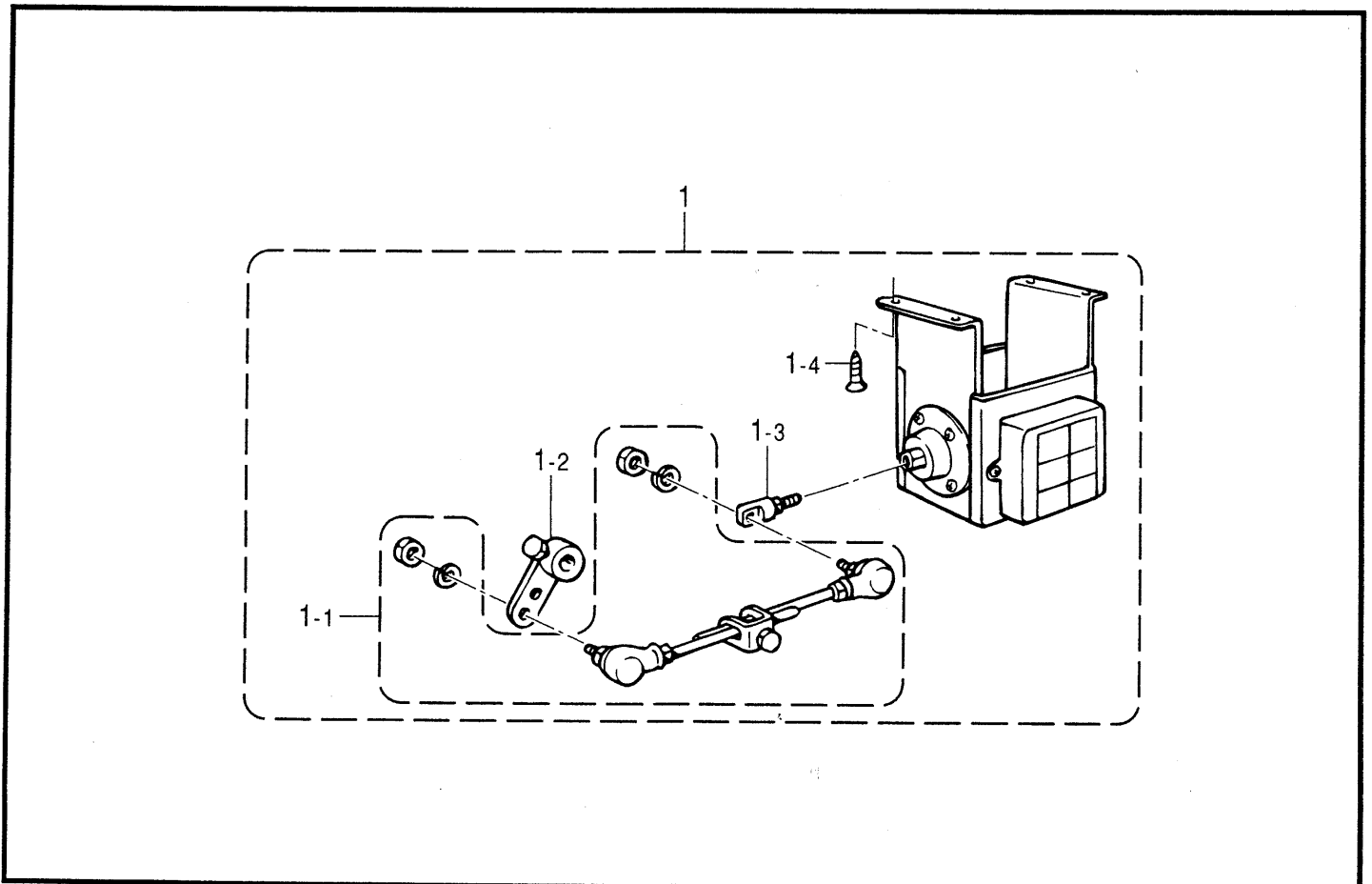

U. 踏板関係 (オプション部品) / Foot switch pedal mechanism (Option parts)

REF.NO.	CODE	Q'TY	ヒンメイ	NAME OF PARTS	RM
1	146175002	1	フミイタソウクミ	TREADLE ASSY	
1-1	146176002	1	フミイタクミ	TREADLE ASSY	
1-2	146178001	1	フミイタヒキバネ	SPRING	
1-3	140953001	1	フミイタヒキバネカケ	SPRING HOOK	
1-4	021500104	2	ナツト1シユ5	NUT, 1 M5	
1-5	025050233	1	ヒラザガネチユウ5	WASHER, PLAIN M 5	
1-6	140947002	1	ウワイタチヨウセツネジ	ADJUSTING SCREW	
1-7	212251001	2	トクナツト4X5	NUT, M4X5	
1-8	028040243	1	バネザガネ2-4	WASHER, SPRING 2-4	
1-9	140954002	1	レンカントリツケウデ	SETTING ARM, CONNECTING ROD	
1-10	062061606	2	ナベコ6X16	SCREW, PAN M6X16	
1-11	025060236	2	ヒラザガネチユウ6	WASHER, PLAIN M 6	
1-12	028060242	2	バネザガネ2-6	WASHER, SPRING 2-6	
1-13	021060206	2	2シユナツト6	NUT, 2 M6	
1-14	109268001	1	フミイタカバー	TREADLE COVER	
1-15	146358001	3	クリツフ6	CLIP, 6	

117-722-651

V1. 電磁押エ上げ関係 (7220, 7240 輸出用) /

Presser foot lifting solenoid set (7220, 7240: -90□)

REF.NO.	CODE	Q'TY	ヒンメイ	NAME OF PARTS	RM
			<輸出用 7220-90□>	<For "7220-90□ of export">	
			<輸出用 7240-90□>	<For "7240-90□ of export">	
1	183962151	1	-----	P-FOOT LIFTER SOLENOID SET, 4	
1-1	S42198051	1	-----	PRESSER FOOT LIFTER ROD ASSY	
1-2	S42199051	1	-----	P-FOOT LIFTER LEVER ASSY	
1-3	S41955051	1	-----	ROD JOINT ASSY	
1-4	S42200051	4	-----	WOOD SCREW	
			<7220 エフカモータ用>	<For "EFKA motor of 7220">	
1	183963151	1	-----	P-FOOT LIFTER SOLENOID SET, 5	
1-1	S42198051	1	-----	PRESSER FOOT LIFTER ROD ASSY	
1-2	S42199051	1	-----	P-FOOT LIFTER LEVER ASSY	
1-3	S41955051	1	-----	ROD JOINT ASSY	
1-4	S42200051	4	-----	WOOD SCREW	

117-722-943

V2 . 電磁押工上ゲ関係 (7220, 7240: オプション部品) /
 Presser foot lifting solenoid set (7220, 7240: Option parts)

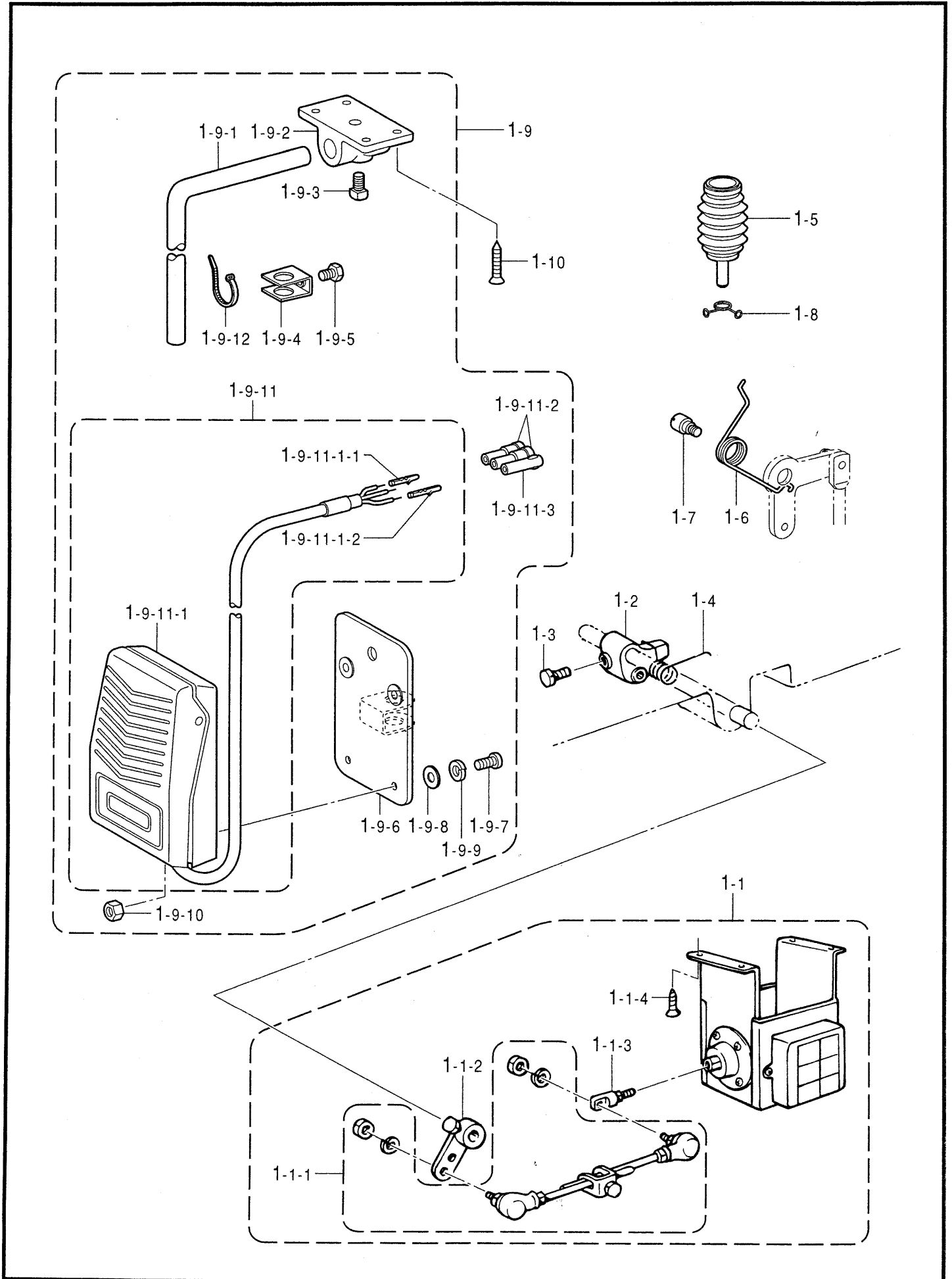

V2. 電磁押エ上げ関係 (7220, 7240: オプション部品)/
 Presser foot lifting solenoid set (7220, 7240: Option parts)

REF.NO.	CODE	Q'TY	ヒンメイ	NAME OF PARTS	RM
			<国内立作業用>	<For use in Japanese>	
1	183969001	1	デンジオサエセット1T	-----	
1-1	183961151	1	デンジオサエセットT	-----	
			<輸出用>	<For Export>	
1	183967001	1	-----	P-FOOT LIFTER SOLENOID SET, 1D	
1-1	183962151	1	-----	P-FOOT LIFTER SOLENOID SET, 4	
			<7220 エフカモータ用>	<For "EFKA motor of 7220">	
1	183968001	1	-----	P-FOOT LIFTER SOLENOID SET, 1E	
1-1	183963151	1	-----	P-FOOT LIFTER SOLENOID SET, 5	
1-1-1	S42198051	1	オサエアゲロッドクミ	PRESSER FOOT LIFTER ROD ASSY	
1-1-2	S42199051	1	オサエアゲレバークミ	P-FOOT LIFTER LEVER ASSY	
1-1-3	S41955051	1	ロッドツギテクミ	ROD JOINT ASSY	
1-1-4	S42200051	4	モクネジ	WOOD SCREW	
1-2	S02595101	1	オサエアゲリンク	PRESSER FOOT LIFTER LINK	
1-3	146367001	1	ボルト5.95	BOLT, SM5.95	
1-4	S02596001	1	ネジリバネ	SPRING, TWIST	
1-5	S16250001	1	ヒザアゲオシボウクミ	KNEE LIFTER COMPLYING BAR ASSY	
1-6	154347001	1	ヒザアゲレバーバネ	SPRING	
1-7	S31010001	1	ダンジク6.35	SHOULDER SCREW, SM6.35	
1-8	S07015001	1	ブーツクリップ	CLIP	
			<国内用膝スイッチ付>	<For use in Japanese>	
1	183970001	1	デンジオサエセット1S	-----	
1-1	183961151	1	デンジオサエセットT	-----	
1-1-1	S42198051	1	オサエアゲロッドクミ	-----	
1-1-2	S42199051	1	オサエアゲレバークミ	-----	
1-1-3	S41955051	1	ロッドツギテクミ	-----	
1-1-4	S42200051	4	モクネジ	-----	
1-2	S02595101	1	オサエアゲリンク	-----	
1-3	146367001	1	ボルト5.95	-----	
1-4	S02596001	1	ネジリバネ	-----	
1-5	S16250001	1	ヒザアゲオシボウクミ	-----	
1-6	154347001	1	ヒザアゲレバーバネ	-----	
1-7	S31010001	1	ダンジク6.35	-----	
1-8	S07015001	1	ブーツクリップ	-----	
1-9	S07045009	1	ヒザスイッチクミ	-----	
1-9-1	142026003	1	ヒザスイッチタテジク	-----	
1-9-2	142027001	1	ヒザスイッチタテジクウケ	-----	
1-9-3	100463001	1	カクボルト7.94	-----	
1-9-4	114967001	1	ヒザアテストツバ	-----	
1-9-5	110087001	1	ボルト5.95	-----	
1-9-6	S07027001	1	ヒザスイッチトリツケイタ	-----	
1-9-7	062401006	4	ナベコ4X10	-----	
1-9-8	025040233	4	ヒラザガネチユウ4	-----	
1-9-9	028040243	4	バネザガネ2-4	-----	
1-9-10	021400164	4	ナツト1シユ4	-----	
1-9-11	S07030009	1	スイッチコードクミ	-----	
1-9-11-1	S07031009	1	フツトスイッチクミ	-----	
1-9-11-1-1	143549000	2	ピンターミナルオス	-----	
1-9-11-1-2	143548000	1	ピンターミナルメス	-----	
1-9-11-2	146046000	2	ナイロンコネクタ	-----	
1-9-11-3	146194000	1	ナイロンコネクタ	-----	
1-9-12	149799000	1	タイラツプS	-----	
1-10	034422503	4	+サラモクネジ4.1X25	-----	

117-722-943

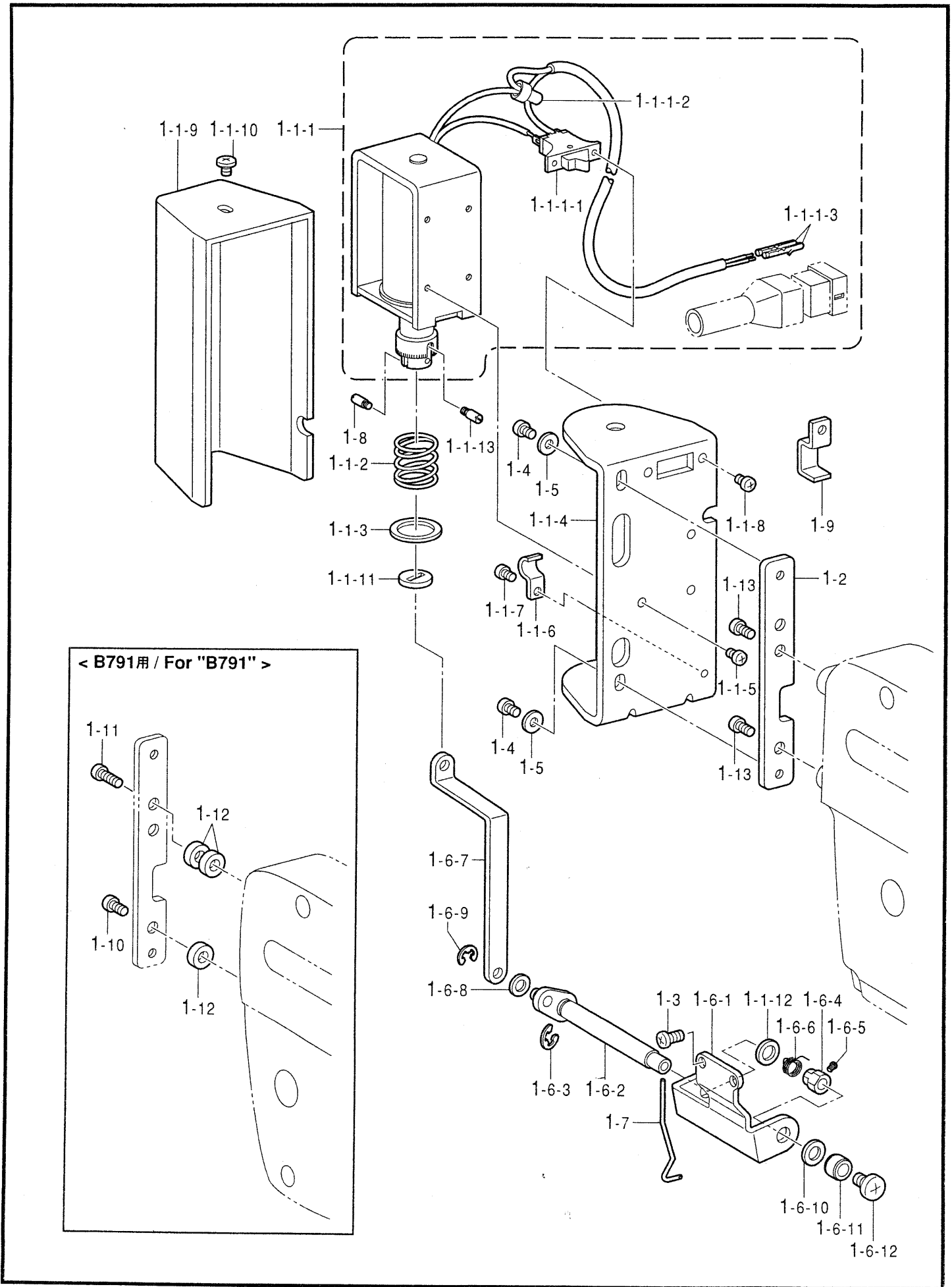

< B791用 / For "B791" >

1-11
1-12
1-10
1-12

W. 糸払イセット関係 (7220, 7240: オプション部品)/
Thread wiper set (7220, 7240: Option parts)

REF.NO.	CODE	Q'TY	ヒンメイ	NAME OF PARTS	RM
1	183887301	1	イトハライセット	THREAD WIPER SET	
1-1	183882101	1	イトハライクミ	THREAD WIPER ASSY	
1-1-1	S41202051	1	イトハライソレノイドクミ	THREAD WIPER SOLENOID ASSY	
1-1-1-1	S02664051	1	イトハライスイッチ	THREAD WIPER SWITCH	
1-1-1-2	S02665050	1	ヘイタンセツゾクシ	CONNECTOR	
1-1-1-3	143549050	2	ピンターミナルオス	TERMINAL PIN, MALE	
1-1-2	S41206001	1	イトハライバネ	SPRING, THREAD WIPER	
1-1-3	S41205001	1	ヒラザガネ	WASHER, PLAIN	
1-1-4	S25449201	1	ソレノイドトリツケイタ	SETTING PLATE, SOLENOID	
1-1-5	062300616	3	ナベコM3X6	SCREW, PAN M3X6	
1-1-6	140647101	1	コードオサエ	CORD HOLDER	
1-1-7	062300616	1	ナベコM3X6	SCREW, PAN M3X6	
1-1-8	062300616	2	ナベコM3X6	SCREW, PAN M3X6	
1-1-9	S33610001	1	ソレノイドカバー	SOLENOID COVER	
1-1-10	060400516	1	バインドM4X5	SCREW, BIND M4X5	
1-1-11	S41207000	1	スパーサゴム	SPACER RUBBER	
1-1-12	149097000	1	シヨウオンシート	SILENT SHEET	
1-1-13	S25456001	2	プランジャピン	PLUNGER PIN	
1-2	S33609101	1	ソレノイドトリツケダイ	SETTING PLATE, SOLENOID	
1-3	062681012	2	ナベコ437-40X10	SCREW, PAN SM4.37-40X10	
1-4	062400616	2	ナベコM4X6	SCREW, PAN M4X6	
1-5	026040236	2	ヒラザガネミガキ4	WASHER, PLAIN 4	
1-6	183888001	1	イトハライジククミ	THREAD WIPER SHAFT ASSY	
1-6-1	S03299009	1	イトハライジクウケイタ	THREAD WIPER SHAFT PLATE	
1-6-2	S34123101	1	イトハライクランククミ	THREAD WIPER CRANK ASSY	
1-6-3	048040342	1	トメワE4	RETAINING RING, E4	
1-6-4	S25454001	1	セツトカラー	SET SCREW COLLAR	
1-6-5	S25279001	1	アタマトメクボミM35-5	SET SCREW, (CP) M3.5-5	
1-6-6	S02678001	1	ワイバーバネ	SPRING	
1-6-7	S03302009	1	イトハライロツド	THREAD WIPER ROD	
1-6-8	110735002	1	ザガネ	WASHER	
1-6-9	048030342	1	トメワE3	RETAINING RING, E3	
1-6-10	S03677001	1	ザガネ	WASHER	
1-6-11	146288001	1	イトハライジクカラー	COLLAR, THREAD WIPER STUD	
1-6-12	060400516	1	バインドM4X5	SCREW, BIND M4X5	
1-7	S45916000	1	イトハライ	THREAD WIPER	
1-8	S25456001	1	プランジャピン	PLUNGER PIN	
1-9	142268001	3	コードオサエL	CORD HOLDER, L	
<hr/>					
1-10	062681012	1	<B791用> ナベコ437-40X10	<For "B791"> SCREW, PAN SM4.37-40X10	
1-11	062681612	1	ナベコ437-40X16	SCREW, PAN SM4.37-40X16	
1-12	S03303001	3	カラー	COLLAR	
<hr/>					
1-13	062680812	2	<7220, 7240 用> ナベコ437-40X8	<For 7220, 7240> SCREW, PAN SM4.37-40X8	

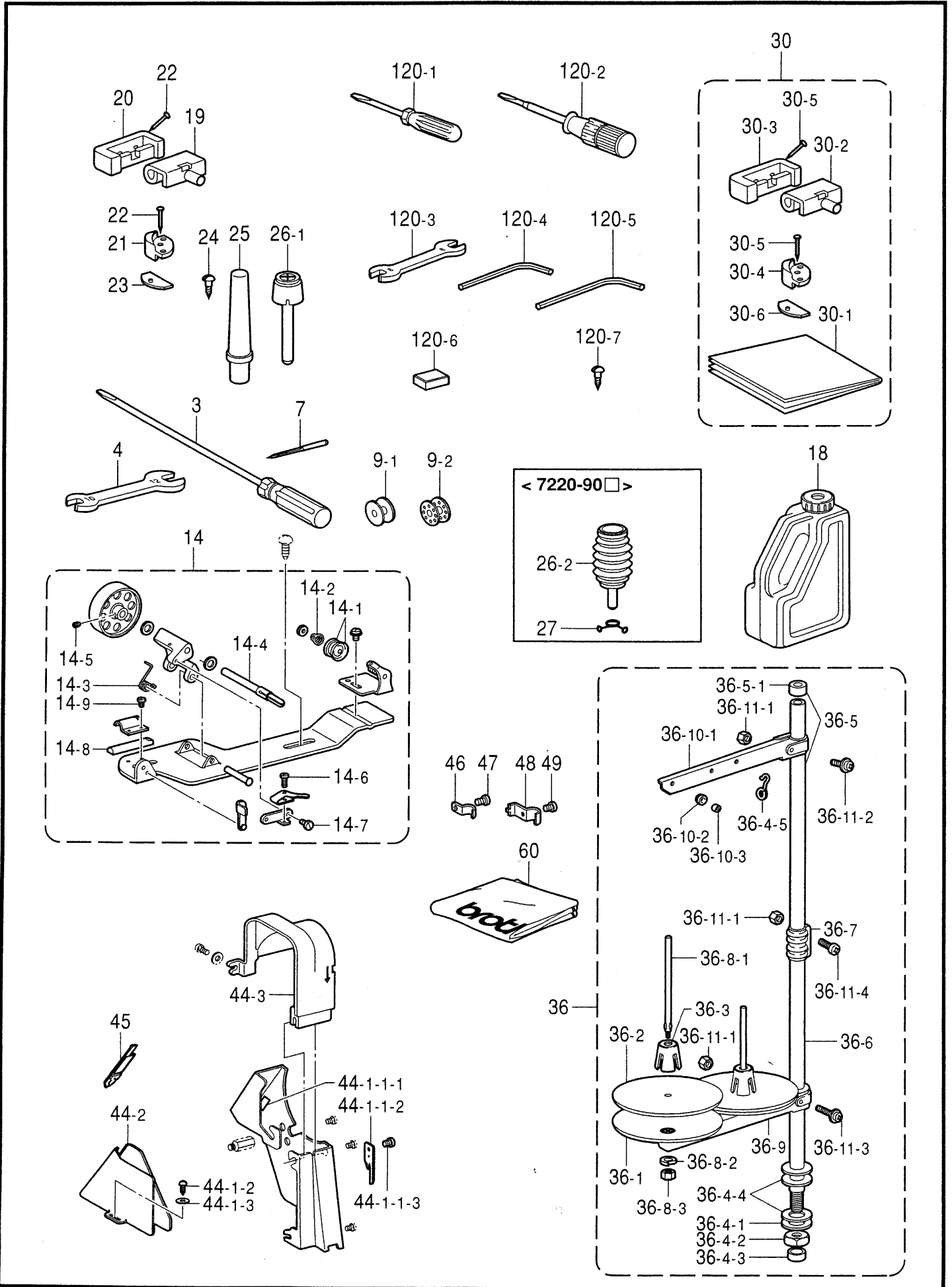

Z. 付属品関係 / Accessories

REF.NO.	CODE	Q'TY	ヒンメイ	NAME OF PARTS	RM
3	S17774001	1	ネジマワシ4.7X250	SCREW DRIVER, 4.7X250	
4	107780001	1	スパナ10X12	WRENCH, 10X12	
7	100265434	1	<7210-3, 7220-□03 用>	<For 7210-3, 7220-□03>	
7	107415414	1	ミシンハリDBX1#14クミ	NEEDLE ASSY, DBX1 (#14)	
		1	ミシンハリDPX5#14クミ	NEEDLE ASSY, DPX5 (#14)	
7	100265442	1	<7210-5, 7220-□05 用>	<For 7210-5, 7220-□05>	
7	107415422	1	<7230, 7240-□05 用>	<For 7230, 7240-□05>	
		1	ミシンハリDBX1#22クミ	NEEDLE ASSY, DBX1 (#22)	
		1	ミシンハリDPX5#22クミ	NEEDLE ASSY, DPX5 (#22)	
9-1	146290001	3	<7210-3 用>	<For 7210-3>	
			<7220-□3, -□05 用>	<For 7220-□3, -□05>	
		3	ボビン	BOBBIN	
9-2	117132001	3	<7210-5 用>	<For 7210-5>	
		3	ボビン	BOBBIN	
9-3	117061001	3	<7230 用>	<For 7230>	
		3	ボビン	BOBBIN	
9-4	159794001	3	<7240 用>	<For 7240>	
		3	ボビン	BOBBIN	
14	S14420110	1	イトマキキクミ	BOBBIN WINDER ASSY	
14-1	145446003	2	イトチヨウシサラ	TENSION DISC	
14-2	100401001	1	イトチヨウシバネ	TENSION SPRING	
14-3	S14423001	1	イトマキジクウケカエリバネ	SPRING	
14-4	S15133001	1	イトマキジク	BOBBIN WINDER SHAFT	
14-5	151602002	1	トメネジ4.37	SET SCREW, SM4.37	
14-6	100657001	1	シメネジ3.18	SCREW, SM3.18	
14-7	100659001	1	ダンネジ3.18	SHOULDER SCREW, SM3.18	
14-8	100662001	1	イトマキクムカイトンドメ	STOPPER, B-WINDER WHEEL	
14-9	S39086001	1	ナベコ357-40X3.5	SCREW, PAN SM3.57-40X3.5	
18	154702101	1	オイルタンク	OIL TANK	
19	143882001	2	<国内用>	<For use in Japanese>	
20	146003109	4	トウブヒンジ	-----	
21	143910009	2	トウブシキゴム	-----	
22	109714000	8	トウブヒンジウケゴム	-----	
23	146004001	4	クギ	-----	
24	100666002	2	オイルパンクシヨン	-----	
		2	マルモクネジ5.5X20	-----	
25	100477009	1	マクラ	HEAD REST	
26-1	S09634000	1	<7210, 7230 用>	<For 7210, 7230>	
			<7220-10□, -30□, -40□ 用>	<For 7220-10□, -30□, -40□>	
			<7240-10□, -30□, -40□ 用>	<For 7240-10□, -30□, -40□>	
		1	ヒザアゲオシボウ	KNEE LIFTER COMPLYING BAR	
26-2	S16250001	1	<7220-90□, 7240-90□ 用>	<For 7220-90□, 7240-90□>	
27	S07015001	1	ヒザアゲオシボウクミ	KNEE LIFTER COMPLYING BAR ASSY	
		1	ブツクリツブ	CLIP	

117-722-910

◎ 付属品の明細は変更することがあります。

◎ The details of included accessories are subject to change.

Z. 付属品関係 / Accessories / Zubehör / Accessoires / Accesorios

REF.NO.	CODE	Q'TY	ヒンメイ	NAME OF PARTS	RM
			<輸出用>	<For Export>	
30	181294009	1	ラバーヒンジクミ	RUBBER & HINGE ASSY	
30-1	144615001	1	テーブルアナカコウズ	TABLE SHEET	
30-2	143882001	2	トウブヒンジ	HEAD HINGE	
30-3	143910009	2	トウブヒンジウケゴム	RUBBER CUSHION	
30-4	146003109	4	トウブシキゴム	HEAD CUSHION	
30-5	109714000	8	クギ	NAIL	
30-6	146004001	4	オイルパンクシヨン	OIL PAN CUSHION	
36	S02763302	1	イトタテダイクミ2DR	COTTON STAND ASSY, 2DR	
36-1	150180001	2	ウケザラ	SPOOL STAND BASE	
36-2	150182000	2	スプールのマット	SPOOL MAT	
36-3	126863001	2	スプールのクツシヨン	SPOOL CUSHION	
36-4	S02777001	1	パイプDネジセットB	PIPE (D) SCREW SET, B	
36-4-1	150206002	1	ヒラザガネ16	WASHER, PLAIN 16	
36-4-2	S38648001	1	6カクナツトU5/8	NUT, U5/8-28	
36-4-3	150174000	1	コラムキャップ	COLUMN CAP	
36-4-4	S01005000	2	イトタテゴム	RUBBER WASHER	
36-4-5	S02747101	1	イトカケバネ	SPRING	
36-5	S40640001	1	コラムパイプキャップツキ	COLUMN PIPE W/CAP	
36-5-1	150174000	1	コラムキャップ	COLUMN CAP	
36-6	156112003	1	コラムパイプD	COLUMN PIPE, D	
36-7	150173003	1	コラムジョイント	COLUMN JOINT	
36-8	S21798001	2	スプールのネジセット	SPOOL SCREW SET	
36-8-1	150179002	2	スプールのジクB	SPOOL SHAFT, B	
36-8-2	028050246	2	バネザガネ2-5	WASHER, SPRING 2-5	
36-8-3	021500106	2	1シユナツト5	NUT, 1 M5	
36-9	S02778002	1	スプールのホルダー2	SPOOL HOLDER, 2	
36-10	S02786002	1	スレツドハンガークミ2	THREAD HANGER ASSY, 2	
36-10-1	S02787002	1	スレツドハンガー2	THREAD HANGER, 2	
36-10-2	150183000	2	イトカケハンガーダイ	THREAD HANGER BASE	
36-10-3	142990001	2	スレツドブツシュ	THREAD BUSH	
36-11	S40641001	1	スプールのジクネジセットA	SPOOL SCREW SET, A	
36-11-1	021500106	4	1シユナツト5	NUT, 1 M5	
36-11-2	S37038001	1	ナベコヒラザ5X14	SCREW, PAN (S/P WASHER) M5X14	
36-11-3	S37037001	1	ナベコヒラザ5X32	SCREW, PAN (S/P WASHER) M5X32	
36-11-4	062501406	2	ナベコ5X14	SCREW, PAN M5X14	
44-1	183658309	1	ベルトカバークミA	BELT COVER ASSY, A	
44-1-1	S15172109	1	ベルトカバー	BELT COVER	
44-1-2	100257010	1	シメネジ3.57	SCREW, SM3.57X6	
44-1-3	100666002	2	マルモクネジ5.5X20	WOOD SCREW, ROUND M5.5X20	
44-1-4	025750132	2	ヒラザガネシヨウ5.56	WASHER, PLAIN S 5.56	
44-2	S14428009	1	ベルトカバーD	BELT COVER, D	
44-3	S37161021	1	ベルトカバーUC	BELT COVER, UC	
45	S37264001	1	ベルトカバーDフタS	LID, S B-COVER (S)	

117-722-910

◎ 付属品の明細は変更することがあります。

◎ The details of included accessories are subject to change.

◎ Änderungen in der Aufstellung der Mitgelieferten Zubehöre sind vorbehalten.

◎ Les détails des accessoires inclus sont sujets à des changements.

◎ Los detalles des accesorios incluidos pueden variar.

Z. 付属品関係 / Accessories

REF.NO.	CODE	Q'TY	ヒンメイ	NAME OF PARTS	RM
48	145597001	1	<7220 エフカモータ用>	<For "EFKA motor of 7220">	
49	062680812	1	-----	CORD STOPPER	
			-----	SCREW, PAN SM4.37-40X8	
60	144222001	1	<輸出用>	<For Export>	
			-----	HEAD COVER	
63	157170101	1	<7220, 7240 DC モータ用>	<For "DC motor of 7220, 7240">	
			コードホルダC	CORD HOLDER, C	
120	183753101	1	<国内用>	<For use in Japanese>	
120-1	142443001	1	パーツクミ	-----	
120-2	118837001	1	ネジマワシ1.9X52	-----	
120-3	100887001	1	ネジマワシ3.4X70	-----	
120-4	146049001	1	スパナ8X9	-----	
120-5	142721001	1	6カクボウスパナ2	-----	
120-6	112525000	1	6カクボウスパナ3	-----	
120-7	100666002	2	シユウジンマグネット	-----	
			マルモクネジ5.5X20	-----	
120	183846101	1	<輸出用>	<For Export>	
120-1	142443001	1	-----	PARTS ASSY	
120-2	118837001	1	-----	SCREW DRIVER, 1.9X52	
120-3	100887001	1	-----	SCREW DRIVER, 3.4X70	
120-4	146049001	1	-----	WRENCH, 8X9	
120-6	112525000	1	-----	HEXAGONAL WRENCH, 2	
120-7	100666002	2	-----	MAGNET	
				WOOD SCREW, ROUND M5.5X20	

117-722-910

◎ 付属品の明細は変更することがあります。

◎ The details of included accessories are subject to change.

仕様 Specification	針板 Needle plate		送り歯 Feed dog				押工組 Presser foot assy	
	Mark			T	P	φ		H
中厚物用 Medium-weight materials	143855	 143855-001	3.2	★ S01158-001 (溝付き/ With slot) 	 φ2	 141158-101		
				S03357-001 			 φ1.4	 S36910-001
				159521-001 			1.15 φ2	 147703-101 面取り小 Chamfering (S)
				159522-001 			 φ2	 S36911-001 面取り小 Chamfering (S)
	147954	147954-001 147954-001	3.2	159914-001 	 φ2.1			

117-721, 722

◎★印はスタンダード専用の送り歯です。

糸切り用に使すると、固定歯が送り歯にあたりますので使用しないで下さい。

◎ Parts marked with a star are feed dogs for standard machines only.

Use with thread trimming machines will cause the fixed knife to strike the feed dog. Avoid such use.

仕様 Specification	針板 Needle plate		送り歯 Feed dog	押工組 Presser foot assy				
	Mark			T	P	ø	H	
中厚物用 Medium-weight materials	143857	143857-001	3.2	★S01159-001 (溝付き / With slot)	1.15	ø2	7	141158-101
	159523-001	3.2	★S01160-001 (溝付き / With slot)	ø2	7	S36910-001		
	148300	148300-001	3.2	★S01160-001 (溝付き / With slot)		ø2		147703-101
								S36911-001

117-721, 722

◎★印はスタンダード専用の送り歯です。

糸切り用に使用すると、固定歯が送り歯にあたりますので使用しないで下さい。

◎Parts marked with a star are feed dogs for standard machines only.

Use with thread trimming machines will cause the fixed knife to strike the feed dog. Avoid such use.

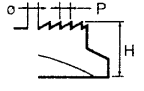
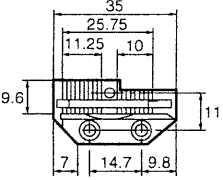
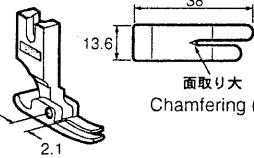
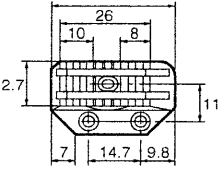
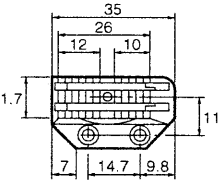
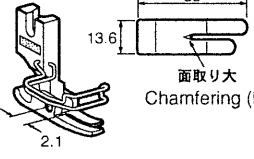
仕様 Specification	針板 Needle plate		送り歯 Feed dog				押工組 Presser foot assy
	Mark			T	P	φ	
厚物用 Heavy-weight materials	148842	148842-001	3.2		1.25	$\phi 2.8$	 140717-101 面取り大 Chamfering (L)
				159526-001			
	S13101	S13101-001	3.2		2.0	$\phi 3.6$	
	S01988	S01988-001	3.2		2.0	$\phi 2.4$	 S36909-001 面取り大 Chamfering (L)



117-721, 722

Ga4 . ゲージ部品一覧表 (7230, 7240) / Gauge parts List (7230, 7240)

仕様 Specification	針板 Needle plate		送り歯 Feed dog	押工組 Presser foot assy				
	Mark			T	P	ø	H	
厚物用 Heavy-weight materials	S13101	S13101-001	3.2	S45903-001	2.0	2.4 3.6	7	S45919-001
					2.0	2.4 3.6		S45920-001

117-723, 724

Wa. 警告ラベル / Warning labels / Warnschilder / Etiquettes d'avertissement
/ Etiquetas de advertencia

警告ラベル / Warning labels	品名 / Name of Parts	Size(mm)	Code
	操作注意ラベル・和	52X84	S38350-001
	Label, operation Eng.	52X84	S38349-001
	アースマーク Label, grounding	φ 12	S37060-001

索引 / INDEX / VERZEICHNIS
/ INDEX / INDICE

CODE	REF.NO.	Page
J80749001	R - 1-4	48
J80750001	R - 1-3	48
J80751001	R - 1-2	48
J80754001	R - 1-5	48
S00857001	H - 9-3	22
S01005000	Z - 36-4-4	59
S01158001	E - 53	16
	Ga1- 53-8	61
S01159001	E - 53	16
	Ga2- 53-9	62
S01160001	Ga2- 53-10	62
S01327001	G - 19	20
S01328001	G - 20	20
S01416000	A - 7	2
S01419000	K - 5	32
S01753001	E - 76	16
S01988001	B - 16	6
	Ga3- 16-9	63
S01989001	E - 53	18
	Ga3- 53-11	63
S01998001	D - 15	10
S02499009	A - 27	2
S02524001	B - 6	4
S02538109	B - 20-2	6
S02539109	B - 20-3	6
S02548001	D - 20	10
S02556001	E - 24	12
S02562001	E - 68	16
S02563001	E - 69	16
S02568101	E - 41	14
S02574101	E - 55	16
S02575000	E - 61	16
S02576001	E - 66-1	16
S02595101	M - 55	44
	J2 - 2-2	30
	V2 - 1-2	54
S02596001	M - 57	44
	J2 - 2-4	30
	V2 - 1-4	54
	V2 - 1-4	54
S02605000	J1 - 3	26
S02606000	J1 - 5	26
S02608001	J1 - 77-1	28
S02609100	J1 - 42	26
S02611001	K - 1-2-1	32
S02612001	K - 1-2-2	32
S02614124	K - 15-1	34
S02617001	K - 19	34
S02620001	K - 8-4	32
	K - 8-4	32
S02647001	L1 - 21	36
	L2 - 21	40
S02648001	L1 - 43	36
	L2 - 43	40
S02652001	L1 - 38	36
	L2 - 38	40
S02654001	L1 - 37-1	36
	L2 - 37-1	40
S02655002	L1 - 40	36
	L2 - 40	40
S02657101	L1 - 42	36
	L2 - 42	40

CODE	REF.NO.	Page
S02658000	N - 1	44
S02659101	N - 2	44
S02660101	N - 8	44
S02664051	P - 50-1	46
	P - 50-1	46
	P - 50-1	46
	W - 1-1-1-1	56
S02665050	P - 50-2	46
	P - 50-2	46
	P - 50-2	46
	W - 1-1-1-2	56
S02678001	P - 72	46
	W - 1-6-6	56
S02682001	L1 - 71-1	38
	L2 - 71-1	42
S02684101	Q - 1	48
S02685001	Q - 2	48
S02687201	Q - 7	48
S02704001	T - 5	50
S02745001	L1 - 72	38
	L2 - 72	42
S02747101	Z - 36-4-5	59
S02763302	Z - 36	59
S02777001	Z - 36-4	59
S02778002	Z - 36-9	59
S02786002	Z - 36-10	59
S02787002	Z - 36-10-1	59
S02805001	B - 2	4
S02815009	L1 - 34	36
	L2 - 34	40
S03254001	K - 8-1	32
	K - 8-1	32
S03299009	P - 67	46
	W - 1-6-1	56
S03302009	P - 73	46
	W - 1-6-7	56
S03303001	W - 1-12	56
S03327000	Q - 6	48
S03328000	L1 - 71-1-1	38
	L2 - 71-1-1	42
S03357001	E - 53	18
	Ga1- 53-12	61
S03670101	N - 15	44
S03677001	P - 82	46
	W - 1-6-10	56
S03815001	L1 - 69-2	38
	L2 - 69-2	42
S04630000	J1 - 2	26
S04632001	K - 8-7	32
S05981000	S - 4	50
S05982000	S - 5	50
S06004001	L1 - 71-2	38
S06684001	J1 - 77	28
S06999101	E - 38-1-1	14
	E - 38-1-1	14
	E - 38-1-1	14
S07015001	Z - 27	58
	V2 - 1-8	54
	V2 - 1-8	54
S07027001	S - 1-6	50
	V2 - 1-9-6	54
S07030009	S - 1-11	50
	V2 - 1-9-11	54

CODE	REF.NO.	Page
S07031009	S - 1-11-1	50
	V2 - 1-9-11-1	54
S07045009	S - 1	50
	V2 - 1-9	54
S07327001	T - 3-2	50
S07656001	E - 19	12
S07818009	L1 - 34	36
S07885000	Q - 9	48
S07959001	E - 14	12
S07972001	K - 7	32
S08003000	J1 - 45	28
S08004001	J1 - 46	28
S09621151	A - 23	2
S09634000	Z - 26-1	58
S09635001	J2 - 1-2	30
S10437000	K - 5	32
S11170001	E - 33	14
S11172101	E - 49	14
S11174001	G - 13	20
S11210000	L1 - 74	38
	L2 - 74	42
S11683000	L1 - 75	38
	L2 - 75	42
S11684000	L1 - 74-1	38
	L2 - 74-1	42
S12441001	K - 8-8	32
	K - 8-8	32
S12699000	K - 5	32
S12717009	A - 18	2
S13101001	B - 16	6
	Ga3- 16-10	63
	Ga4- 16-10	64
S13102101	E - 53	16
	Ga3- 53-13	63
S13385001	D - 29	10
S13654001	G - 7	20
S13665001	G - 16	20
S13688009	G - 5	20
S13690009	G - 5	20
S13691009	G - 5	20
S14420110	Z - 14	58
S14423001	Z - 14-3	58
S14428009	Z - 44-2	59
S15133001	Z - 14-4	58
S15172109	Z - 44-1-1	59
S15889001	J2 - 1-6	30
S16250001	Z - 26-2	58
	V2 - 1-5	54
	V2 - 1-5	54
S16299001	C - 1	8
S16325001	E - 1	12
S16327001	E - 2	12
S16330101	E - 9	12
S16331001	E - 17	12
S16332001	E - 18	12
S16333100	E - 13	12
S16334001	E - 21	12
S16397100	J1 - 15	26
S16432001	E - 42	14
S17774001	Z - 3	58
S19056001	K - 12	34
S19135001	E - 1	12
S19137001	E - 66-1	16

CODE	REF.NO.	Page
S20553001	H -21-1	24
S21514101	E -38-1-3	14
	E -38-1-3	14
	E -38-1-3	14
S21798001	Z -36-8	59
S23836001	L1 -37	36
	L2 -37	40
S25279001	P -71	46
	W -1-6-5	56
S25349021	E -50	14
S25375001	N -9	44
S25437000	L1 -18	36
	L2 -18	40
S25449201	P -54	46
	W -1-1-4	56
S25454001	P -70	46
	W -1-6-4	56
S25456001	P -78	46
	P -85	46
	W -1-1-13	56
	W -1-8	56
S31006001	D -23	10
S31010001	D -33	10
	V2 -1-7	54
	V2 -1-7	54
S31012001	D -3	10
S31013001	D -4	10
S31014000	E -43	14
	E -56	16
S31015101	E -38-1	14
S31016001	E -38-1-2	14
S31018101	E -38-1	14
S31019001	E -38-1-2	14
S31026000	H -6-1	22
S31027000	H -13	22
S31031001	K -8	32
S31032001	K -8-9	32
	K -8-9	32
S31034001	K -8	32
S31885001	F -8-8	20
S32348001	J1 -39-1	26
S32349001	J1 -43	28
S32903000	T -1-2	50
S32904000	T -1-3	50
S32905000	T -1-4	50
S32906000	T -1-5	50
	T -1-5	50
S32910000	T -1-5	50
S32916000	T -1-5	50
S32919000	E -73	16
S32922001	E -26-1	12
S32926001	J1 -11	26
S32930000	J1 -10	26
S33609101	P -59	46
	W -1-2	56
S33610001	P -65	46
	W -1-1-9	56
S33680001	E -30-2	12
S33681001	E -26-2	12
S33689002	B -21	6
S34123101	P -68	46
	W -1-6-2	56
S34295001	B -12-1	4

CODE	REF.NO.	Page
S34448001	A -201	2
	R -2	48
S34756001	F -8-5	20
S34758001	F -8	20
S36909001	D -28	10
	D -28	10
	Ga3-28-4	63
S36910001	D -28	10
	Ga1-28-5	61
	Ga2-28-5	62
S36911001	D -28	10
	Ga1-28-6	61
	Ga2-28-6	62
S37037001	Z -36-11-3	59
S37038001	Z -36-11-2	59
S37060001	Wa	65
S37161021	Z -44-3	59
S37264001	Z -45	59
S37333001	E -35	14
S38349001	Wa	65
S38350001	Wa	65
S38648001	Z -36-4-2	59
S39086001	Z -14-9	58
S39829001	E -85	18
S39830001	E -86	18
S40016001	J1 -28	26
S40017000	J1 -27	26
S40640001	Z -36-5	59
S40641001	Z -36-11	59
S41202051	P -50	46
	W -1-1-1	56
S41205001	P -53	46
	W -1-1-3	56
S41206001	P -52	46
	W -1-1-2	56
S41207000	P -83	46
	W -1-1-11	56
S41955051	M -50-3	44
	V1 -1-3	52
	V1 -1-3	52
	V2 -1-1-3	54
	V2 -1-1-3	54
S42195051	P -50	46
S42196051	P -50	46
S42198051	M -50-1	44
	V1 -1-1	52
	V1 -1-1	52
	V2 -1-1-1	54
	V2 -1-1-1	54
S42199051	M -50-2	44
	V1 -1-2	52
	V1 -1-2	52
	V2 -1-1-2	54
	V2 -1-1-2	54
S42200051	M -50-4	44
	V1 -1-4	52
	V1 -1-4	52
	V2 -1-1-4	54
	V2 -1-1-4	54
S43669000	J1 -29	26
S45671001	L2 -64	40
S45801109	K -17-1	34
S45806001	B -1	4

CODE	REF.NO.	Page
S45808001	B -9-1	4
S45809000	B -9-1-1	4
S45810001	B -9-2	4
S45811000	B -9-2-1	4
S45815001	B -12-2	4
S45816001	C -2	8
S45817101	C -5	8
S45818101	C -10	8
S45819001	C -18	8
S45820001	C -18-1	8
S45821001	C -31	8
S45822001	C -31	8
S45823101	C -19	8
S45828001	C -31	8
S45829001	C -31	8
S45830001	C -31	8
S45831001	C -31	8
S45832000	E -72	16
S45833001	C -20	8
S45834001	C -21	8
S45835000	C -22	8
S45836000	C -26	8
S45837001	D -21	10
S45838001	E -34-1	14
S45840101	E -34-2	14
S45842001	E -3	12
S45843001	G -1	20
S45844000	J1 -1	26
S45845000	J1 -13	26
S45846000	J1 -14	26
S45848001	J1 -51	28
S45849000	J1 -65	28
S45850001	J1 -48	28
S45851000	J1 -53	28
S45854000	J1 -48-2	28
S45856001	J1 -54	28
S45857109	K -17-2	34
S45860001	T -1	50
S45861001	T -1-1	50
S45862001	T -1	50
S45863001	T -1	50
S45876001	J1 -48-1	28
S45877001	A -200	2
S45887001	B -9-3	4
S45888000	B -9-3-1	4
S45889001	C -31	8
S45890001	C -31	8
S45895001	R -1-1	48
S45897001	B -12-3	4
S45899001	L2 -8	40
S45900001	L1 -60	38
	L2 -60	40
S45903001	E -53	16
	Ga4-53-2	64
S45904101	E -38-1	14
S45905001	E -38-1-2	14
S45908001	D -16	10
S45911901	H -20-1	24
S45912901	H -20-1	24
S45914001	E -66-1	16
S45916000	P -79	46
	W -1-7	56
S45918901	H -20-2	24

CODE	REF.NO.	Page
S45919001	D - 28	10
	Ga4- 28-1	64
S45920001	D - 28	10
	Ga4- 28-2	64
S45922001	Ga4- 53-3	64
S46734001	D - 10	10
S46736001	D - 12	10
013660612	L1 - 62	38
	L2 - 62	40
013760610	B - 5	4
	C - 12	8
	H - 5	22
013761410	E - 1-1	12
	E - 1-1	12
	H - 7	22
013781012	B - 13	6
014500536	C - 25	8
014680422	C - 17	8
	C - 19-1	8
	E - 16	12
	J1 - 77-2	28
014680622	A - 202	2
	C - 7	8
	E - 3-2	12
	E - 12	12
	E - 20	12
	H - 12	22
	K - 3	32
	R - 3	48
	L1 - 37-2	36
	L2 - 37-2	40
014760622	E - 8	12
014761030	E - 23	12
014770622	L1 - 27	36
	L2 - 27	40
014771022	B - 11	4
	L1 - 3	36
	L2 - 3	40
014780622	C - 9	8
	E - 10	12
017762013	F - 8-3	20
021060206	U - 1-13	52
021400164	S - 1-10	50
	V2 - 1-9-10	54
021500104	U - 1-4	52
021500106	Z - 36-8-3	59
	Z - 36-11-1	59
025040233	S - 1-8	50
	V2 - 1-9-8	54
025050233	U - 1-5	52
025060236	U - 1-11	52
025100132	E - 29	12
025350132	D - 31	10
025750132	Z - 44-1-4	59
026040236	P - 64	46
	W - 1-5	56
028040243	S - 1-9	50
	U - 1-8	52
	V2 - 1-9-9	54
028050240	E - 37	14
028050246	Z - 36-8-2	59
028060242	U - 1-12	52
034422503	S - 2	50

CODE	REF.NO.	Page
034422503	V2 - 1-10	54
047200642	E - 66-1-2	16
	E - 66-1-2	16
	E - 66-1-2	16
048030342	P - 75	46
	W - 1-6-9	56
048040342	D - 14	10
	G - 10	20
	P - 69	46
	W - 1-6-3	56
048060342	L1 - 33	36
	L2 - 33	40
048070342	E - 25	12
048080342	E - 28	12
048120142	C - 15	8
048150142	E - 45	14
	E - 58	16
048180142	L2 - 10	40
060300606	T - 1-6	50
060400516	P - 66	46
	P - 80	46
	W - 1-1-10	56
	W - 1-6-12	56
060670612	K - 20	34
	N - 7	44
062061606	U - 1-10	52
062061616	C - 18-2	8
062300616	P - 55	46
	P - 57	46
	P - 58	46
	W - 1-1-5	56
	W - 1-1-7	56
	W - 1-1-8	56
062351216	D - 24	10
062400616	P - 63	46
	W - 1-4	56
062401006	S - 1-7	50
	V2 - 1-9-7	54
062401416	N - 10	44
062500602	G - 18	20
062500812	G - 6	20
062501406	Z - 36-11-4	59
062501616	C - 23	8
062630712	Q - 8	48
062670412	E - 82	16
062670612	A - 24	2
	Q - 13	48
	Q - 18	48
	T - 2	50
	T - 4	50
	J1 - 12	26
	J1 - 52	28
062670616	J1 - 50	28
062670712	E - 31	14
062670812	N - 5	44
	J1 - 39-5	26
	L1 - 44	36
	L2 - 44	40
062671612	D - 34	10
062672012	C - 27	8
	K - 18	34
	N - 13	44
062680663	L1 - 73	38

CODE	REF.NO.	Page
062680663	L2 - 73	42
062680812	A - 128	2
	E - 77	16
	K - 16	34
	P - 60	46
	R - 5	48
	W - 1-13	56
	Z - 49	60
	J1 - 41	26
	L1 - 66	38
	L2 - 66	40
062681012	A - 28	2
	P - 76	46
	W - 1-3	56
	W - 1-10	56
062681212	E - 48	14
	H - 19-2	24
	L1 - 11	36
062681412	E - 59-1	16
062681612	Q - 4	48
	W - 1-11	56
062711012	Q - 11	48
062711212	E - 62	16
062711412	Q - 20	48
	L1 - 19	36
	L2 - 19	40
062760812	A - 129	2
062781412	G - 2	20
081001670	J1 - 26	26
081004070	J1 - 44	28
081007070	J1 - 60	28
	J2 - 1-11	30
	J2 - 2-9	30
081014670	J1 - 6	26
100022004	J2 - 1-5	30
100032004	B - 17	6
100080003	E - 54	16
100251001	B - 8-1	4
	B - 9-1-2	4
	B - 9-2-2	4
	B - 9-3-2	4
	H - 1-1-1	22
	H - 1-2-1	22
	H - 2-1-1	22
	H - 2-2-1	22
100257010	Z - 44-1-2	59
100265434	Z - 7	58
100265442	Z - 7	58
100328001	E - 40	14
100367001	H - 18-1	22
100400000	K - 5	32
100401001	Z - 14-2	58
100402004	K - 8-3	32
	K - 8-3	32
100463001	F - 8-2	20
	S - 1-3	50
	V2 - 1-9-3	54
100477009	Z - 25	58
100511003	E - 83	18
100645003	A - 131	2
	Q - 3	48
	L1 - 10	36
	L1 - 65	38

CODE	REF.NO.	Page
100645003	L2 - 65	40
100657001	Z - 14-6	58
100659001	Z - 14-7	58
100662001	Z - 14-8	58
100666002	Z - 24	58
	Z - 44-1-3	59
	Z - 120-7	60
	Z - 120-7	60
100887001	Z - 120-3	60
	Z - 120-3	60
101487000	J1 - 21	26
101706001	E - 46-1	14
	E - 60-1	16
	H - 17-1	22
102571003	L1 - 16	36
	L2 - 16	40
102630001	B - 15	6
102707001	D - 25	10
102716004	K - 4-1-3	32
102843004	L1 - 61	38
	L2 - 61	40
103950003	K - 6	32
104449009	A - 17	2
	J1 - 4	26
104450109	A - 12	2
104451109	A - 14	2
104464001	B - 10	4
104520000	H - 15	22
104525001	K - 8-7	32
104564001	E - 30-1	12
104619002	F - 8-4	20
104689002	E - 64	16
104821009	A - 16	2
104829101	A - 2	2
104830101	A - 3	2
104832009	A - 13	2
104885101	J2 - 1-4	30
105234003	L1 - 26	36
	L2 - 26	40
106436001	J1 - 31	26
107155001	J1 - 34	26
107407003	H - 19-1	24
107415414	Z - 7	58
107415422	Z - 7	58
107780001	Z - 4	58
108520009	A - 15	2
108549001	E - 38-1-4	14
	E - 38-1-4	14
	E - 38-1-4	14
108960002	E - 80	16
109160001	H - 9-1	22
109173101	H - 10	22
109268001	U - 1-14	52
109714000	Z - 22	58
	Z - 30-5	59
109763002	D - 13	10
110087001	F - 8-7	20
	S - 1-5	50
	V2 - 1-9-5	54
110161004	N - 3	44
110201001	L1 - 39	36
	L2 - 39	40
110367001	B - 14	6

CODE	REF.NO.	Page
110367001	L1 - 32	36
	L2 - 32	40
110735002	P - 74	46
	W - 1-6-8	56
110744002	C - 4	8
111466101	D - 1	10
111468001	B - 12-1-3	4
	B - 12-2-3	4
	B - 12-3-3	4
111863001	J1 - 2	26
111865009	A - 29	2
	J1 - 64	28
112467002	J1 - 39-8	26
112525000	Z - 120-6	60
	Z - 120-6	60
113431002	Q - 10	48
114294001	K - 8-10	32
	K - 8-10	32
114561001	B - 18-1	6
114931001	K - 1-1	32
114967001	F - 8-6	20
	S - 1-4	50
	V2 - 1-9-4	54
116112001	K - 9	32
116735000	B - 12-2-4	4
	B - 12-3-4	4
116794001	J1 - 33	26
116922001	K - 8-2	32
	K - 8-2	32
117061001	H - 22-3	24
	Z - 9-3	58
117132001	H - 22-2	24
	Z - 9-2	58
117936009	A - 20	2
118672001	A - 5	2
118681001	B - 16	6
118734001	E - 4	12
118735001	E - 5	12
118758001	E - 65	16
118761001	H - 11-1	22
118768001	B - 12-3-6	6
118837001	Z - 120-2	60
	Z - 120-2	60
120023001	C - 14	8
120990001	E - 51	14
121007001	H - 16	22
122771051	B - 18-2	6
126863001	Z - 36-3	59
140004001	B - 12-1-2	4
	B - 12-2-2	4
	B - 12-3-2	4
140092001	C - 16	8
140518001	J1 - 59	28
	J2 - 1-10	30
	J2 - 2-8	30
140553102	C - 29	8
140647101	P - 56	46
	Q - 12	48
	T - 3-1	50
	W - 1-1-6	56
140704001	A - 4	2
140715001	B - 16	6
140717101	D - 28	10

CODE	REF.NO.	Page
140717101	Ga3- 28-1	63
140726000	B - 4	4
140882901	H - 20-1	24
140947002	U - 1-6	52
140953001	U - 1-3	52
140954002	U - 1-9	52
141156001	B - 16	6
141158101	D - 28	10
	Ga1- 28-2	61
	Ga2- 28-2	62
141208001	D - 7	10
141542001	J1 - 72	28
141728001	D - 5	10
142026003	S - 1-1	50
	V2 - 1-1-1	54
142027001	S - 1-2	50
	V2 - 1-9-2	54
142268001	W - 1-9	56
142274009	A - 21	2
	L1 - 63	38
	L2 - 63	40
142403001	D - 8-1	10
142443001	Z - 120-1	60
	Z - 120-1	60
142708000	H - 4	22
142721001	Z - 120-5	60
142746002	E - 38-1-5	14
	E - 38-1-5	14
	E - 38-1-5	14
142990001	Z - 36-10-3	59
143548000	S - 1-11-1-2	50
	S - 5-2	50
	L1 - 74-2	38
	L2 - 74-2	42
	V2- 1-9-11-1-2	54
143549000	G - 5-2	20
	G - 5-2	20
	S - 1-11-1-1	50
	S - 4-1	50
	S - 5-1	50
	L1 - 74-3	38
	L2 - 74-3	42
	V2- 1-9-11-1-1	54
143549050	P - 50-3	46
	P - 50-3	46
	W - 1-1-1-3	56
143855001	B - 16	6
	Ga1- 16-4	61
143857001	B - 16	6
	Ga2- 16-5	62
143882001	Z - 19	58
	Z - 30-2	59
143910009	Z - 21	58
	Z - 30-3	59
144222001	Z - 60	60
144458001	E - 75	16
144502001	K - 4-1	32
144504001	K - 1-2-3	32
	K - 4-1-1	32
144505000	K - 4-1-2	32
144615001	Z - 30-1	59
144869002	J1 - 39-2	26
144872101	J1 - 40	26

CODE	REF.NO.	Page
144874001	J1 - 39-4	26
144875001	J1 - 39-6	26
144876001	J1 - 39-7	26
144878001	J1 - 39-9	26
145446001	K - 8-5	32
	K - 8-5	32
145446003	Z - 14-1	58
145465001	B - 12-1-1	4
	B - 12-2-1	4
	B - 12-3-1	4
145471109	B - 20-1	6
145472001	D - 2	10
145478101	D - 17	10
145479002	D - 18	10
145480101	D - 19	10
145502001	E - 39	14
145516001	H - 3-1	22
145522101	K - 11	34
145534001	J1 - 32	26
145580001	D - 9	10
145597001	Z - 48	60
145624000	B - 12-1-5	4
	B - 12-2-5	4
	B - 12-3-5	4
145751001	J1 - 31	26
146003109	Z - 20	58
	Z - 30-4	59
146004001	Z - 23	58
	Z - 30-6	59
146036101	J2 - 1-1	30
	J2 - 2-1	30
146039001	F - 8-1	20
146040001	J1 - 58	28
	J2 - 1-9	30
	J2 - 2-7	30
146046000	S - 1-11-2	50
	S - 4-2	50
	V2- 1-9-11-2	54
146049001	Z - 120-4	60
	Z - 120-4	60
146064000	J1 - 30	26
146105009	G - 17	20
146175002	U - 1	52
146176002	U - 1-1	52
146178001	U - 1-2	52
146194000	S - 1-11-3	50
	S - 5-3	50
	V2- 1-9-11-3	54
146196001	J1 - 37	26
146253000	J1 - 38	26
146288001	P - 81	46
	W - 1-6-11	56
146290001	H - 22-1	24
	Z - 9-1	58
146293001	J2 - 1-7	30
	J2 - 2-5	30
146327001	J1 - 23	26
146331001	B - 6	4
146333001	J1 - 22	26
146358001	U - 1-15	52
146367001	M - 56	44
	J2 - 1-3	30
	J2 - 2-3	30

CODE	REF.NO.	Page
146367001	V2 - 1-3	54
	V2 - 1-3	54
147337001	H - 18-3	24
147338109	K - 15-2	34
147504201	E - 27	12
147509001	E - 63	16
147557101	K - 4-2	32
147703101	D - 28	10
	Ga1- 28-3	61
	Ga2- 28-3	62
147777000	B - 12-1-4	4
147790001	H - 21-2	24
147954001	B - 16	6
	Ga1- 16-6	61
148300001	B - 16	6
	Ga2- 16-7	62
148350101	H - 21-1	24
148537101	L1 - 13	36
	L2 - 13	40
148825001	Q - 19	48
148842001	B - 16	6
	Ga3- 16-8	63
148846901	H - 20-1	24
148849001	J1 - 39-3	26
148967101	H - 21-1-4	24
	H - 21-1-4	24
	H - 21-2-4	24
149094001	G - 14	20
149095001	G - 15	20
149097000	P - 84	46
	W - 1-1-12	56
149578000	J1 - 57-1-1	28
	J2 - 1-8-1	30
	J2 - 2-6-1	30
149580571	J1 - 57-1	28
	J2 - 1-8	30
	J2 - 2-6	30
149799000	S - 1-12	50
	V2 - 1-9-12	54
150173003	Z - 36-7	59
150174000	Z - 36-4-3	59
	Z - 36-5-1	59
150179002	Z - 36-8-1	59
150180001	Z - 36-1	59
150182000	Z - 36-2	59
150183000	Z - 36-10-2	59
150206002	Z - 36-4-1	59
150384101	D - 30	10
150551000	K - 5	32
151308101	C - 24	8
	E - 15	12
151429001	J1 - 49	28
151439002	E - 7	12
151594001	C - 28	8
151602002	Z - 14-5	58
151604001	E - 66-1-1	16
	E - 66-1-1	16
	E - 66-1-1	16
151607001	L1 - 23	36
	L2 - 23	40
151844001	H - 21-2-4	24
151845001	H - 21-2	24
	H - 21-2-1	24

CODE	REF.NO.	Page
151987002	L1 - 15	36
	L2 - 15	40
153132000	E - 70	16
153138001	G - 9	20
153245001	G - 8	20
153483001	K - 10	34
153484001	E - 36	14
153969000	L1 - 68	38
	L2 - 68	40
153970001	L1 - 69-1	38
	L2 - 69-1	40
154347001	D - 32	10
	V2 - 1-6	54
	V2 - 1-6	54
154552001	H - 9-2	22
154562001	K - 1-2-4	32
154566021	L1 - 1	36
	L2 - 1	40
154567000	L1 - 2	36
	L2 - 2	40
154569001	L1 - 64	38
154570001	L1 - 8	36
154571001	L1 - 9	36
154576003	L1 - 14	36
	L2 - 14	40
154579001	L2 - 20	40
154581001	L1 - 22	36
	L2 - 22	40
154582021	L1 - 24	36
	L2 - 24	40
154590001	L1 - 25	36
	L2 - 25	40
154593201	L1 - 28	36
	L2 - 28	40
154594000	L1 - 29	36
	L2 - 29	40
154595001	L1 - 30	36
	L2 - 30	40
154596000	L1 - 31	36
	L2 - 31	40
154598001	L1 - 35	36
	L2 - 35	40
154599000	L1 - 36	36
	L2 - 36	40
154606001	N - 4	44
154607101	N - 6	44
154702101	Z - 18	58
154730001	G - 5-1	20
	G - 5-1	20
	G - 5-1	20
155347001	N - 14-2	44
155488000	B - 12-1-6	4
	B - 12-2-6	4
155559001	L1 - 47	36
	L2 - 47	40
156112003	Z - 36-6	59
156217009	A - 19	2
	J1 - 76	28
156244020	E - 47	14
156264001	C - 6	8
156620000	L2 - 9	40
156623001	L1 - 20	36
156626009	L1 - 34	36

brother®

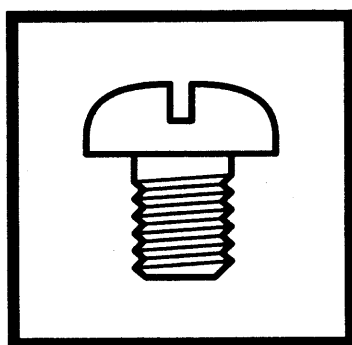

パーツブック
PARTS BOOK

ブラザー工業株式会社

〒467-8561 名古屋市瑞穂区苗代町 15 番 1 号 TEL (052) 824-2392

BROTHER INDUSTRIES, LTD

15-1, Naeshiro-cho, Mizuho-ku, Nagoya 467-8561, Japan. Phone : 81-52-824-2177

Printed in Japan

117-721,722,723,724
S95721-201
2002.07. H (1)