

SL-7340

パーツブック
PARTS BOOK
TEILEKATALOG
LIVRE DES PIECES
LIBRO DE REFERENCIA DE PIEZAS

直線本縫ミシン

SINGLE-NEEDLE STRAIGHT LOCK STITCHER

EINNADEL-STEPPSTICH-SCHNELLNÄHER

PIQUEUSE POINT NOUE - 1 AIGUILLE

PUNTADA RECTA 1 AGUJA



brother®

パーツブックご利用に際して

1. この本は、2000年5月のデータに基づいて作成されたものです。
2. 部品は予告なしに設計変更される場合があります。
3. 組単位で補給する部品は、 破線で示しております。

目 次

A. 主体関係.....	1
B. 膝上げ関係.....	1
C. 針棒・天秤関係	3
D. 押工関係.....	5
E. 送り関係.....	7
F. カマ関係.....	11
G. 給油潤滑関係.....	13
H. 糸通シ関係.....	15
Z. 付属品関係.....	17
Wa. 警告ラベル.....	19
索引.....	20

Notes for using this parts book

1. This book was prepared based on information available in May 2000.
2. Parts are subject to changes in design without prior notice.
3. Parts supplied as complete assemblies are circled by a dotted line .

CONTENTS

A. Machine body	1
B. Knee lifter mechanism	1
C. Needle bar and thread take-up mechanism	3
D. Presser foot mechanism	5
E. Feed mechanism	7
F. Rotary hook mechanism	11
G. Lubrication	13
H. Threading mechanism	15
Z. Accessories	17
Wa. Warning labels	19
INDEX	20

Hinweise zur Verwendung dieser Teileliste

1. Dieses Buch basiert auf den Informationen vom Mai 2000.
2. Modelländerungen sind vorbehalten.
3. Die Teile, die als kompletter Satz geliefert werden, sind mit einer  gestrichelten Linie umrandet.

INHALTSVERZEICHNIS

A. Maschinengehäuse	1
B. Kniehebel	1
C. Nadelstange und Fadenabnahmevorrichtung	3
D. Stoffdrückerfuß	5
E. Transportvorrichtung	7
F. Greifervorrichtung	11
G. Schmierung	13
H. Fadenführungsvorrichtung	15
Z. Zubehör	17
Wa. Warnschilder	19
VERZEICHNIS	20

Notes sur l'utilisation de ce manuel de pièces détachées

1. Ce manuel a été fait d'après les renseignements valables au mois de Mai 2000.
2. Les pièces peuvent être sujettes à des modifications sans préavis.
3. Les pièces fournies en tant qu'assemblages complets sont encadrées avec un trait pointillé [] .

TABLE DES MATIERES

A. Corps de la machine	1
B. Mécanisme de genouillère	1
C. Mécanisme de la barre à aiguille et releveur de fil ...	3
D. Mécanisme de pied presseur	5
E. Mécanisme de l'entraînement	7
F. Mécanisme du crochet rotatif	11
G. Lubrification	13
H. Mécanisme de l'enfilage	15
Z. Accessoires	17
Wa. Etiquettes d'avertissement	19
INDEX	20

Notas para usar este Manual de Piezas

1. Este libro ha sido compilado basándose en los datos de que se disponía en mayo 2000.
2. Las piezas quedan sujetas a cambios de diseño sin aviso previo.
3. Las piezas suministradas como conjuntos completos se enmarcan con una línea punteada [] .

INDICE

A. Cuerpo de la máquina	1
B. Mecanismo de levantador de rodilla	1
C. Mecanismo de la barra de aguja y tirahilos	3
D. Mecanismo de la prensa tela	5
E. Mecanismo de la alimentación	7
F. Mecanismo del cangrejo	11
G. Lubricación	13
H. Mecanismo del enhebrado	15
Z. Accesorios	17
Wa. Etiquetas de advertencia	19
INDICE	20

A. 主体関係 / Machine body / Maschinengehäuse / Corps de la machine / Cuerpo de la máquina

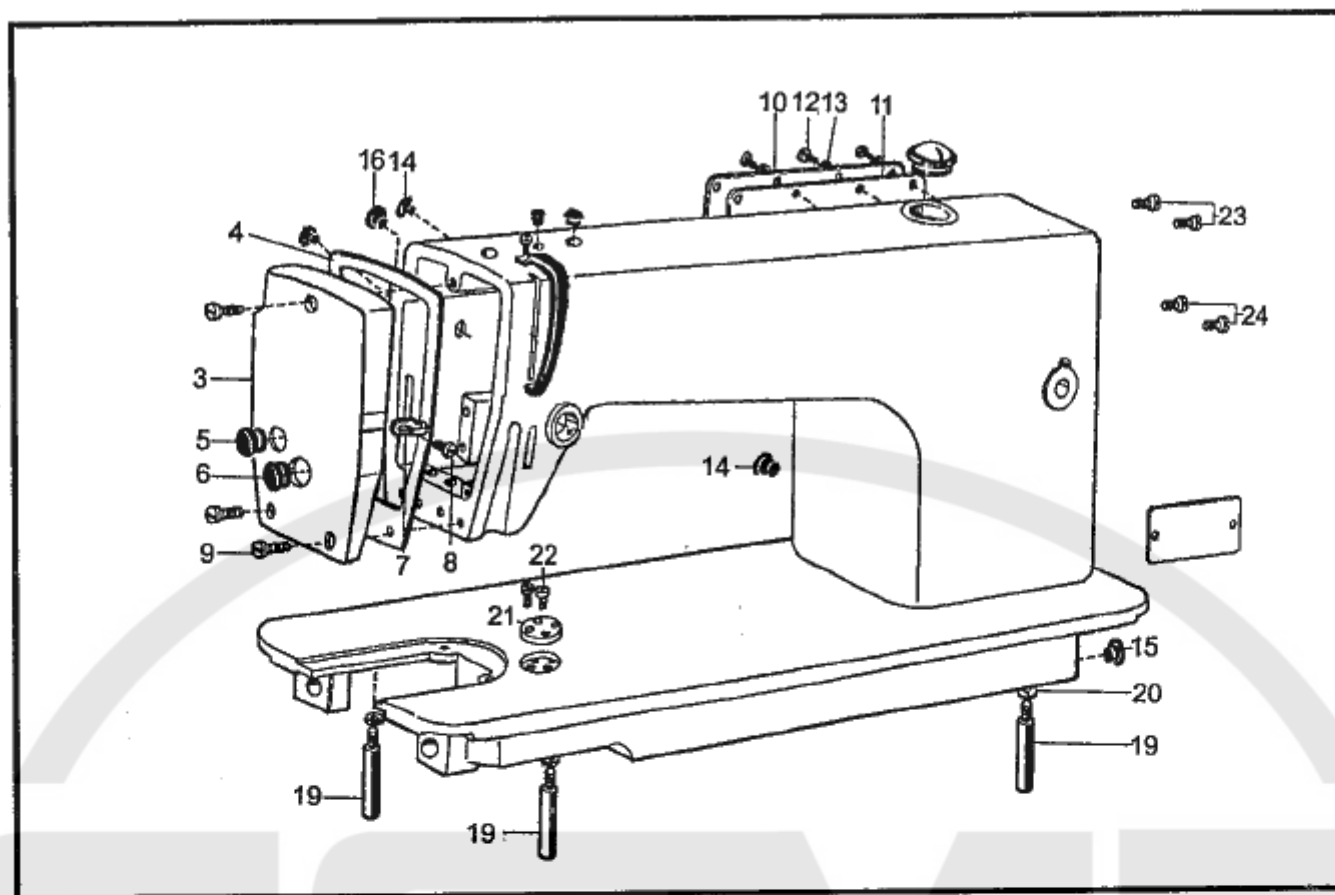

877 - 734 - 050

B. 膝上げ関係 / Knee lifter mechanism / Kniehebel / Mécanisme de genouillère / Mecanismo de levantador de rodilla

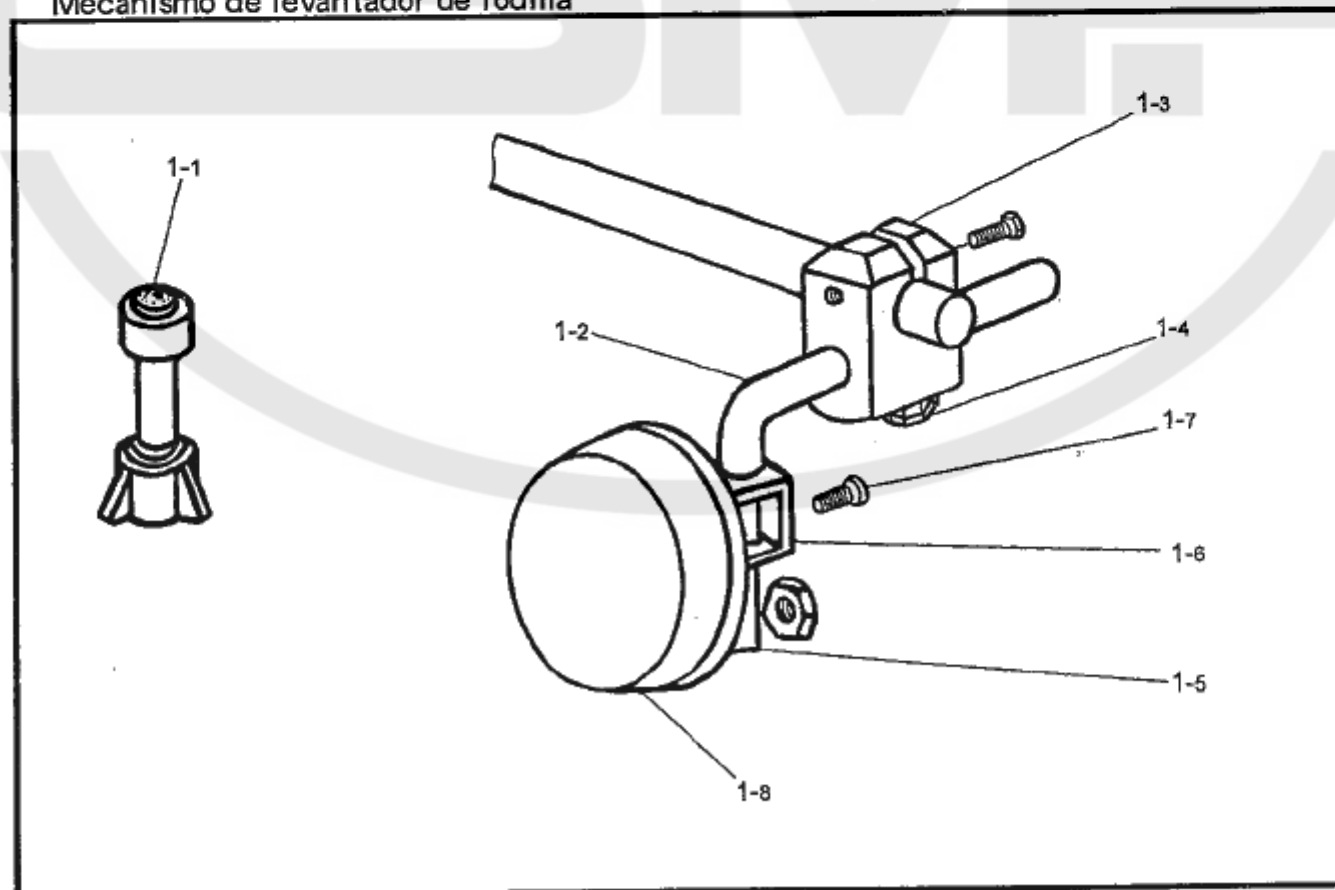

877 - 734 - 203

A. 主体関係/Machine body/Maschinengehäuse/Corps de la machine/Cuerpo de la máquina

REF. NO.	CODE	Q'TY	ヒンメイ	NAME OF PARTS	RM
3	SW5008001	1	メンイタ	FACE PLATE	
4	SW5009001	1	メンイタパツキン	PACKING, ;F-PLATE	
5	SW5010001	1	ゴムセン19	RUBBER CAP, 19	
6	SW5011001	2	ゴムセン11.8	RUBBER CAP, 11.8	
7	SW5012001	1	メンイタイトアンナイ	THREAD GUIDE, ;F-PLATE	
8	SW5013001	1	シメネジ3.57×40×6	SCREW, SM 3.57-40×6	
9	SW5014001	3	シメネジ4.37×40×10	SCREW, SM 4.37-40×10	
10	SW5015001	1	ガワイタ	REAR PLATE	
11	SW5016001	1	ガワイタパツキン	PACKING, ;R-PLATE	
12	SW5017001	8	シメネジ4.37×40×9	SCREW, SM 4.37-40×9	
13	SW5018001	8	ザガネ	WASHER, PLAIN	
14	SW5019001	2	ゴムセン8.8	RUBBER CAP, 8.8	
15	SW5020001	1	ゴムセン27	RUBBER CAP, 27	
16	SW5010001	1	ゴムセン19	RUBBER CAP, 19	
19	SW5021001	3	キヤクテユウ	BED LEG	
20	SW5022001	3	バネザガネ	WASHER, SPRING	
21	SW5023001	1	ジヨウギイタ	RULLER PLATE	
22	SW5024001	2	シメネジ4.37×40×5.5	SCREW, SM 4.37-40×5.5	

877-734-050

B. 膝上げ関係/Knee lifter mechanism/Kniehebel/Mécanisme de genouillère/
Mecanismo de levantador de rodilla

REF. NO.	CODE	Q'TY	ヒンメイ	NAME OF PARTS	RM
1	SW5200001	1	ヒザアテクミ	KNEE LIFTER ASSY	
1-1	SW5201001	1	ヒザアゲオシボウ	LIFTER BAR, ;KNEE	
1-2	SW5202001	1	ヒザアゲタテジク	LIFTER BAR, ;KNEE	
1-3	SW5203001	1	ヒザアテツギテ	LIFTER JOINT	
1-4	SW5204001	2	シメネジ M 6×12(20)	SCREW, M 6×12(20)	
1-5	SW5205001	1	ヒザアテ	KNEE LIFTER PLATE	
1-6	SW5206001	1	ヒザアテストップ	STOPPER, ;K-LIFTER PLATE	
1-7	SW5207001	1	シメネジ 5.95×28×8	SCREW, SM 5.95-28×8	
1-8	SW5208001	1	ヒザアテカバー	COVER, ;K-LIFTER PLATE	

877-734-203

C. 針棒・天秤關係/Needle bar and thread take-up mechanism/Nadelstange und Fadenabnahmevorrichtung/
 Mécanisme de la barre à aiguille et releveur de fil/Mecanismo de la barra de aguja y tirahilos

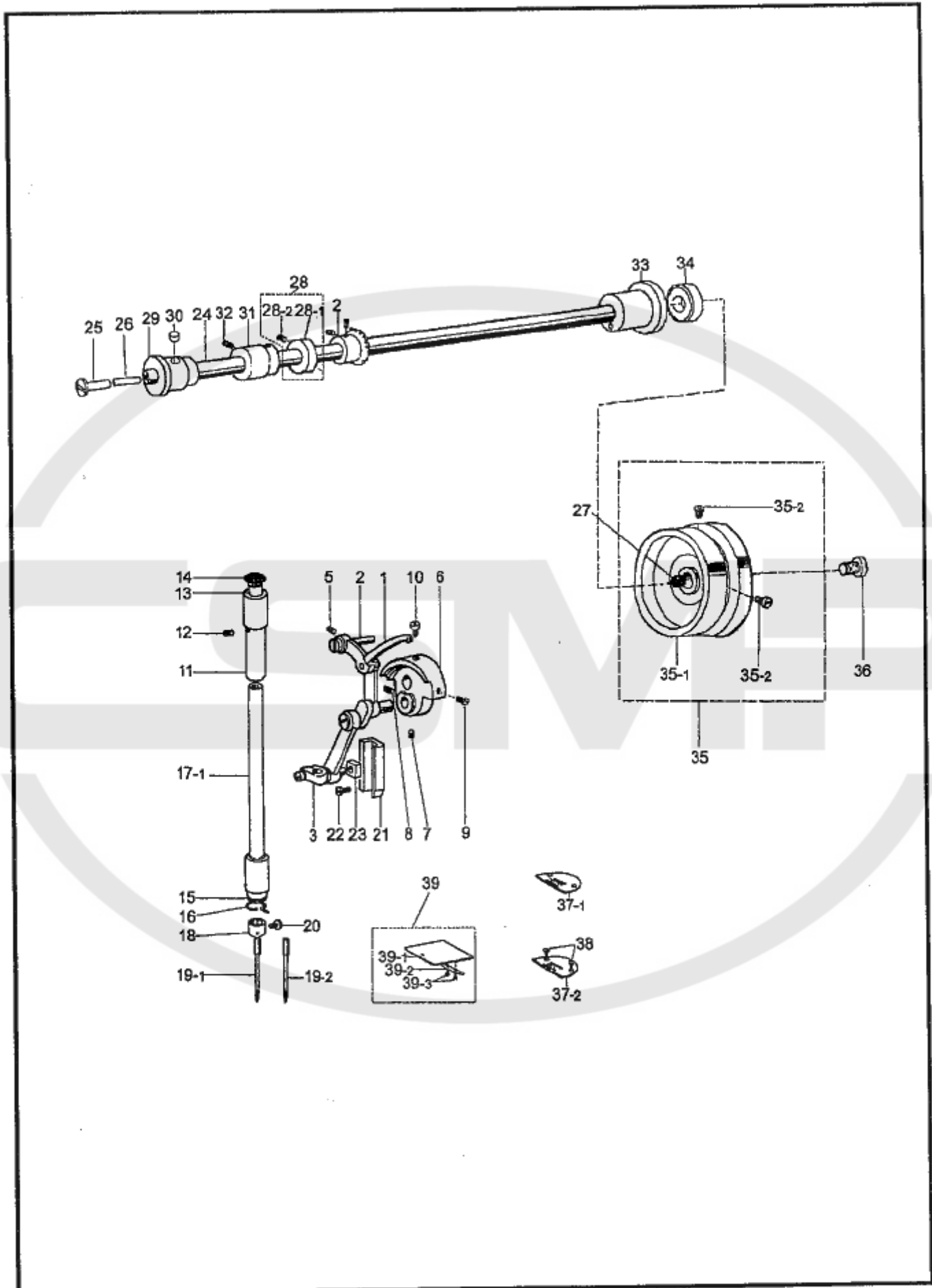

C. 針棒・天秤関係/Needle bar and thread take-up mechanism/Nadelstange und Fadenabnahmevorrichtung/
 Mécanisme de la barre à aiguille et releveur de fil/Mecanismo de la barra de aguja y tirahilos

REF. NO.	CODE	Q'TY	ヒンメイ	NAME OF PARTS	RM
1	SW5025001	1	テンピンクミ	THREAD TAKE-UP LEVER ASSY	
2	SW5031001	1	テンピンササエジク	SUPPORT SHAFT, ;T/TAKE-UP	
3	SW5038001	1	ハリボウダキ	NEEDLE BAR CLAMP	
5	SW5041001	1	トメネジ5.95×28×10	SET SCREW, SM 5.95-28×10	
6	SW5043001	1	テンピンクラック	THREAD TAKE-UP CRANK	
7	SW5044001	1	シメネジ6.35×40×5	SCREW, SM 6.35-40×5	
8	SW5045001	1	アナトメネジ6.35×40×7	SET SCREW, SOCKET SM 6.35-40×7	
9	SW5046001	1	シメネジ7.14×28×13	SCREW, SM 7.14-28×13	
10	SW5047001	1	トメネジ7.14×28×14	SET SCREW, SM 7.14-28×14	
11	SW5048001	1	ハリボウメタルU	BUSH, U; N-BAR	
12	SW5049001	1	トメネジ5.95×28×4.5	SET SCREW, SM 5.95-28×4.5	
13	SW5050001	1	ハリボウフェルト	FELT, ; N-BAR	
14	SW5051001	1	ゴムセン8.8	RUBBER CAP, 8.8	
15	SW5052001	1	ハリボウメタルD	BUSH, D; N-BAR	
16	SW5053001	1	ハリボウメタルイトアンナイ	THREAD GUIDE, ; N-BAR BUSH	
17-1	SW5054001	1	ハリボウDB	NEEDLE BAR, DB	
17-2	SW5056001	1	ハリボウDP	NEEDLE BAR, DP	
18	SW5055001	1	ハリボウイトアンナイ	THREAD GUIDE, ; N-BAR	
19-1	100265034	1	ミシンハリDB×1	NEEDLE, DB×1(#14)	
19-2	107415014	1	ミシンハリDP×5	NEEDLE, DP×5(#14)	
20	SW5057001	1	トメネジ3.18×44×4.5	SET SCREW, SM 3.18-44×4.5	
21	SW5058001	1	ハリボウアンナイ	GUIDE, ; N-BAR	
22	SW5059001	2	シメネジ4.37×40×8	SCREW, SM 4.37-40×8	
23	SW5060001	1	ハリボウアンナイカクコマ	SLIDE BLOCK, ; N-BAR GUIDE	
24	SW5062001	1	ウワジク	UPPER SHAFT	
25	SW5063001	1	オイルチョウウセツベン	REGULATOR VALVE, ; OIL	
26	SW5064001	1	フェルト	FELT	
27	SW5065001	1	ゴムセン7.4×10	RUBBER CAP, 7.4×10	
28	SW5066001	1	セットカラークミ	SET SCREW COLLAR ASSY	
28-1	SW5067001	1	セットカラー	SET SCREW COLLAR	
28-2	SW5068001	2	トメネジ6.35×40×4	SET SCREW, SM 6.35-40×4	
29	SW5070001	1	ウワジクメタル	BUSH, ; U-SHAFT	
30	SW5071001	1	フェルト	FELT	
31	SW5072001	1	ウワジクメタルM	BUSH, M; U-SHAFT	
32	SW5041001	1	トメネジ5.95×28×10	SET SCREW, SM 5.95-28×10	
33	SW5074001	1	ウワジクメタルR	BUSH, R; U-SHAFT	
34	SW5075001	1	オイルシール	OIL SEAL	
35	SW5078001	1	プーリクミ	PULLEY ASSY	
35-1	SW5079001	1	プーリ	PULLEY	
35-2	SW5080001	2	アタマトメクボミ	SET SCREW, (CP)	
36	SW5081001	1	ナベコ	SCREW, PAN	
37-1	SW5082001	1	ハリイタE18	NEEDLE PLATE, E18	
37-2	SW5100001	1	ハリイタE16	NEEDLE PLATE, E16	
38	SW5083001	2	サラネジ4.37×40×4.5	SCREW, FLAT SM 4.37-40×4.5	
39	SW5084001	1	スベリイタクミ	SLIDE PLATE ASSY	
39-1	SW5085001	1	スベリイタ	SLIDE PLATE	
39-2	SW5086001	1	スベリイタウワバネ	SPRING, PLATE; S-PLATE	
39-3	SW5087001	2	シメネジ2.38×56×2.2	SCREW, SM 2.38-56×2.2	

D. 押工関係/Presser foot mechanism/Stoffdrückerfuß/Mécanisme de pied presseur/
Mecanismo de la prensa tela

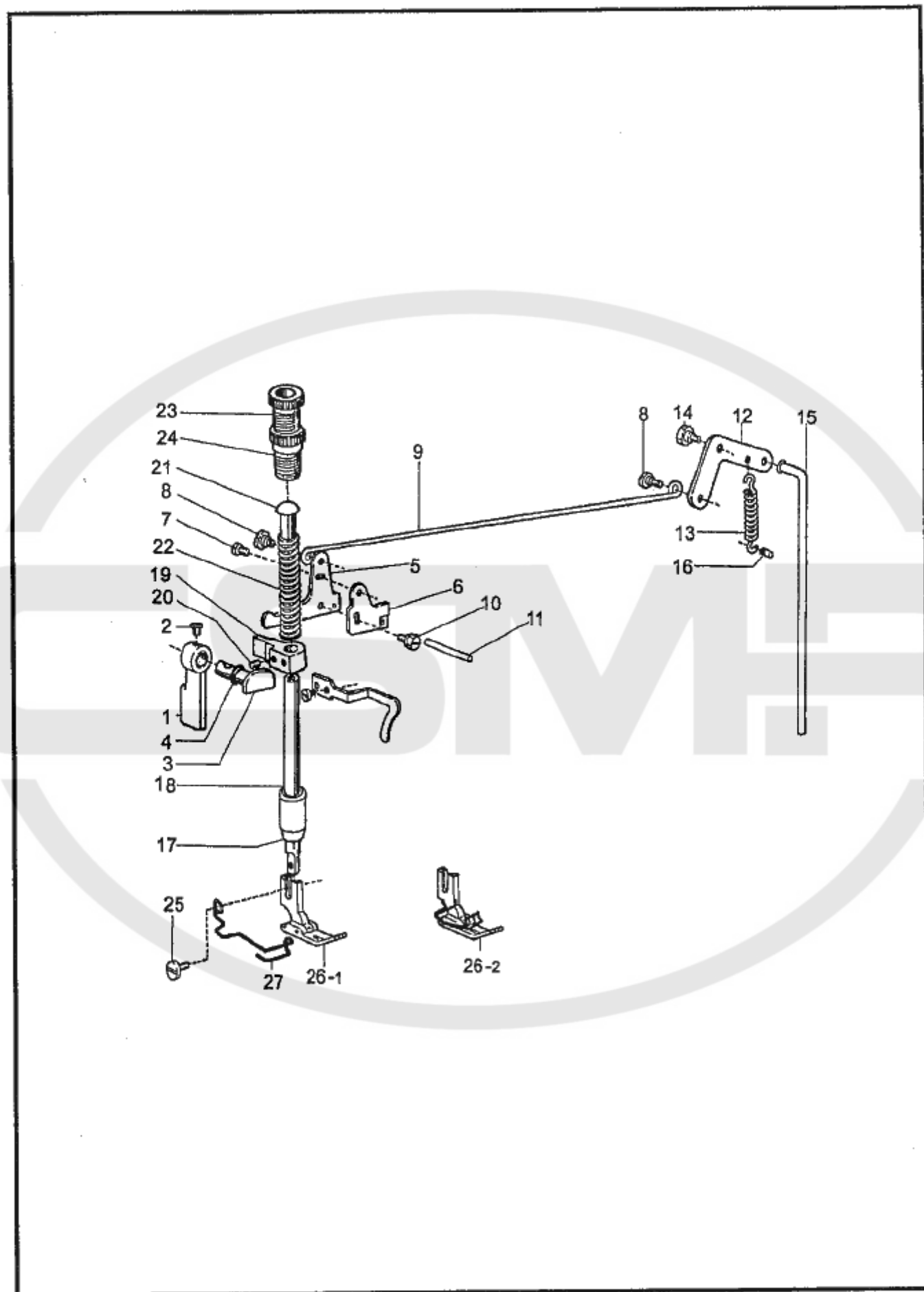

877 - 734 - 201

D. 押工関係/Presser foot mechanism/Stoffdrückerfuß/Mécanisme de pied presseur/
Mecanismo de la prensa tela

REF. NO.	CODE	Q'TY	ヒンメイ	NAME OF PARTS	RM
1	SW5088001	1	オサエアゲテコ	PRESSER BAR LIFTER	
2	SW5017001	1	シメネジ4.37×40×9	SCREW, SM 4.37-40×9	
3	SW5089001	1	オサエアゲクランク	LIFTER CRANK, ;P- BAR	
4	SW5090001	1	Oリング	O RING	
5	SW5091001	1	オサエアゲレバー L	LIFTER LEVER, L; P- BAR	
6	SW5092001	1	イトユルメイタ	TENSION RELEASE PLATE	
7	SW5093001	1	トメネジ4.37×40×6.5	SET SCREW, SM 4.37-40×6.5	
8	SW5094001	2	ダンネジ4.76×28×4	SHOULDER SCREW, SM 4.76-28×4	
9	SW5095001	1	ヒザアゲレンカン	CONNECTING ROD, ;K- LIFTER	
10	SW5096001	1	シメネジ5.95×28×14	SCREW, SM 5.95-28×14	
11	SW5097001	1	イトユルメボウ	STUD, ;T- RELEASE	
12	SW5098001	1	オサエアゲレバー R	LIFTER LEVER, R; P- BAR	
13	SW5099001	1	オサエアゲレバーバネ	SPRING	
14	SW5096001	1	シメネジ5.95×28×14	SCREW, SM 5.95-28×14	
15	SW5101001	1	ヒザアゲボウ	KNEE LIFTER BAR	
16	SW5102001	1	バネピン	PIN, SPRING	
17	SW5103001	1	オサエボメタル	BUSH, ;P- BAR	
18	SW5105001	1	オサエボウ	PRESSER BAR	
19	SW5106001	1	オサエボウダキ	PRESSER BAR CLAMP	
20	SW5107001	1	ボルト5.95×28×8	BOLT, SM 5.95-28×8	
21	SW5108001	1	オサエバネアンナイ	SPRING GUIDE	
22	SW5109001	1	オサエバネ	SPRING, COMPRESSION	
23	SW5110001	1	ネジ12.7×28×49	SCREW, SM 12.7-28×49	
24	SW5111001	1	チヨウセツネツツマミナ	NUT, ;P- ADJUSTING	
25	SW5112001	1	ツト	SCREW, SM 3.57-40×11	
26-1	SW5113001	1	シメネジ3.57×40×11	PRESSER FOOT ASSY	
26-2	SW5114001	1	オサエクミ	PRESSER FOOT ASSY, W/F- GUARD	
27	SW5118001	1	オサエクミ F.G フィンガーガード	FINGER GUARD	

E. 送り関係/Feed mechanism/Transportvorrichtung/Mécanisme de l'entraînement/
Mecanismo de la alimentación

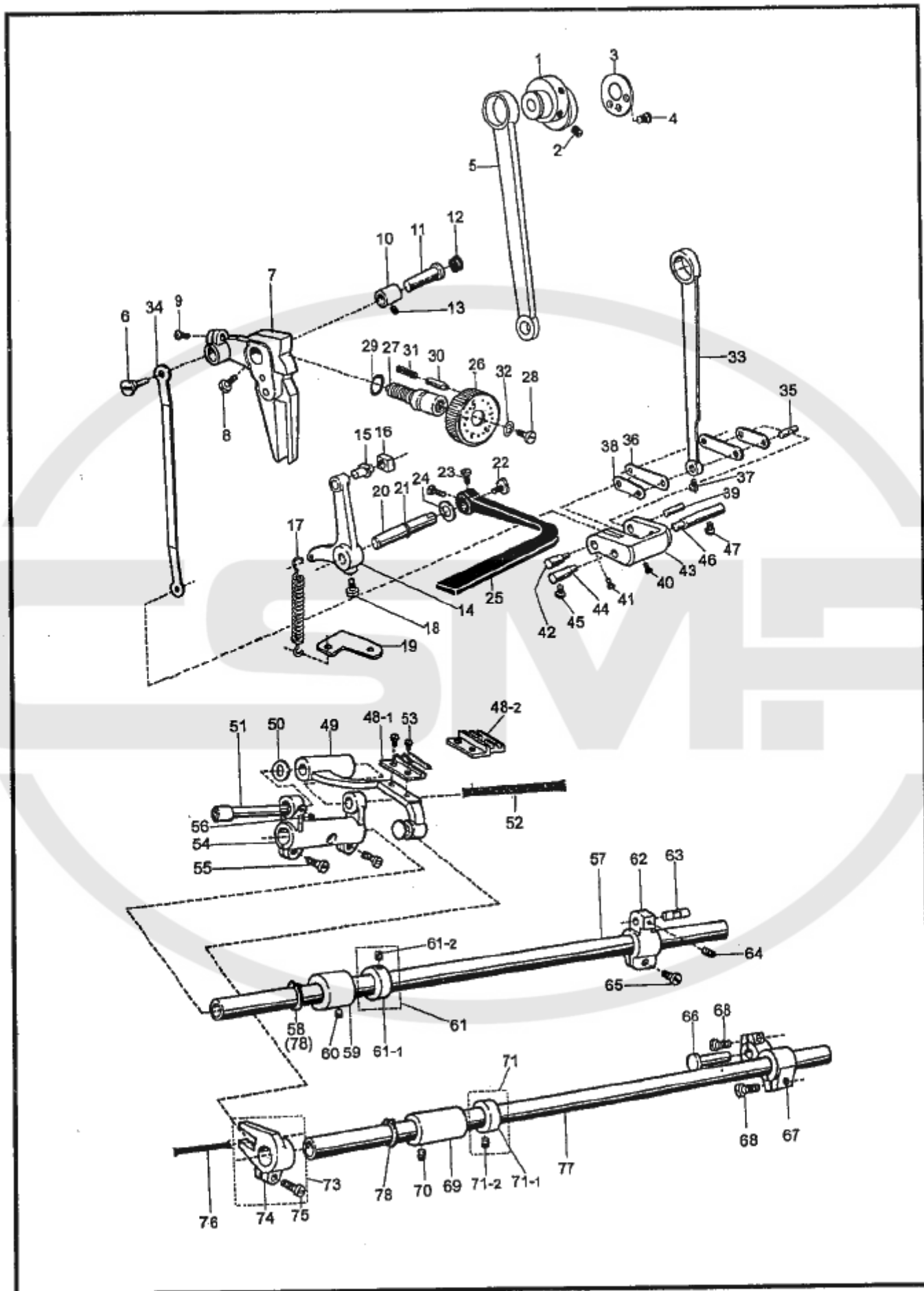

877-734-202

E. 送り関係/Feed mechanism/Transportvorrichtung/Mécanisme de l'entraînement/
Mecanismo de la alimentación

REF. NO.	CODE	Q'TY	ヒンメイ	NAME OF PARTS	RM
1	SW5119001	1	オクリヘンシンリン	FEED ECCENTRIC WHEEL	
2	SW5107001	2	ボルト5.95×28×8	BOLT, SM 5.95-28×8	
3	SW5120001	1	レンカンオサエ	HOLDER	
4	SW5121001	3	サラネジ3.57×40×4.5	SCREW, FLAT SM 3.57-40×4.5	
5	SW5122001	1	シヨゲオクリレンカン	CONNECTING ROD, ;V-FEEDING	
6	SW5123001	1	レンカンジク	CONNECTING STUD	
7	SW5124001	1	オクリチヨウセツキ	FEED REGULATOR	
8	SW5125001	1	トメネジ5.95×28×8.5	SET SCREW, SM 5.95-28×8.5	
9	SW5059001	1	シメネジ4.37×40×8	SCREW, SM 4.37-40×8	
10	SW5126001	1	メタル	BUSH	
11	SW5127001	1	オクリチヨウセツキジク	SHAFT, ;F-REGULATOR	
12	SW5128001	1	ゴムセン	RUBBER CAP	
13	SW5041001	1	トメネジ5.95×28×10	SET SCREW, SM 5.95-28×10	
14	SW5129001	1	レバー	LEVER	
15	SW5130001	1	レバーカクコマジサエ	SHAFT, ;SLIDE BLOCK	
16	SW5131001	1	レバーカクコマ	SLIDE BLOCK, ;LEVER	
17	SW5132001	1	ヒキバネ	SPRING, EXTENSION	
18	SW5133001	1	アナボルト	BOLT, SOCKET	
19	SW5134001	1	バネカケ	SPRING HOOK	
20	SW5135001	1	カエシヌイレバージク	SHAFT, ;R-STICHING LEVER	
21	SW5099001	1	オサエアゲレバーバネ	SPRING	
22	SW5137001	1	シメネジ4.76×28×6.5	SCREW, SM 4.76-28×6.5	
23	SW5125001	2	トメネジ5.95×28×8.5	SET SCREW, SM 5.95-28×8.5	
24	SW5139001	1	ザガネ	WASHER, PLAIN	
25	SW5140001	1	カエシヌイレバー	REVERSE STITCHING LEVER	
26	SW5141001	1	オクリメモリダイヤル	STITCH LENGTH DIAL	
27	SW5142001	1	オクリチヨウセツネジ	ADJUSTING SCREW	
28	SW5143001	1	シメネジ4.76×28×8	SCREW, SM 4.76-28×8	
29	SW5144001	1	Oリング	O RING	
30	SW5145001	1	メモリイチギメピン	POSITIONING PIN	
31	SW5146001	1	メモリイチギメピンバネ	SPRING, COMPRESSION	
32	SW5147001	1	メモリイタオサエ	PLATE SUPPORT	
33	SW5148001	1	スイヘイオクリレンカン	LEVEL FEED CONNECTING ROD	
34	SW5149001	1	キリカエキレンカン	CONNECTING ROD	
35	SW5150001	1	リンクジク	SHAFT	
36	SW5151001	2	スイヘイオクリウデリンク	LINK, ;L-FEED ROCKER ARM	
37	SW5152001	1	トメネジ4.37×40×7	SET SCREW, SM 4.37-40×7	
38	SW5153001	2	スイヘイオクリリンク	FEED ROCKER LINK	
39	SW5154001	1	オクリリンクジク	SHAFT, ;F-ROCKER LINK	
40	SW5155001	1	トメネジ3.57×40×8.5	SET SCREW, SM 3.57-40×8.5	
41	SW5156001	1	トメネジ3.57×40×6.5	SET SCREW, SM 3.57-40×6.5	
42	SW5157001	1	ヘンシンピン	PIN	
43	SW5158001	1	キリカエキ	FEED REGULATOR	
44	SW5159001	1	キリカエキジクL	SHAFT, L;F-REGULATOR	
45	SW5160001	1	トメネジ4.37×40×12	SET SCREW, SM 4.37-40×12	
46	SW5161001	1	キリカエジク	SHAFT, ;F-REGULATOR	
47	SW5160001	1	トメネジ4.37×40×12	SET SCREW, SM 4.37-40×12	
48-1	SW5163001	1	オクリバ3	FEED DOG,3	
48-2	SW5165001	1	オクリバ4	FEED DOG,4	
49	SW5164001	1	オクリダイクミ	FEED BAR ASSY	
50	SW5169001	1	ザガネ	WASHER, PLAIN	
51	SW5170001	1	オクリダイジク	SHAFT, ;F-BAR	
52	SW5171001	1	クミヒモ	WICK	
53	SW5172001	2	シメネジ3.18×44×6	SCREW, SM 3.18-44×6	
54	SW5173001	1	スイヘイオクリダイウデ	FEED ROCKER BRACKET ARM	
55	SW5174001	2	シメネジ4.76×28×12	SCREW, SM 4.76-28×12	
56	SW5059001	1	シメネジ4.37×40×8	SCREW, SM 4.37-40×8	
57	SW5175001	1	スイヘイオクリジク	SHAFT, ;F-ROCKER	
58	SW5176001	1	トメワジクヨウ	RETAINING RING, C EXTERNAL	
59	SW5177001	1	メタル	BUSH	

E. 送り関係/Feed mechanism/Transportvorrichtung/Mécanisme de l'entraînement/
Mecanismo de la alimentación

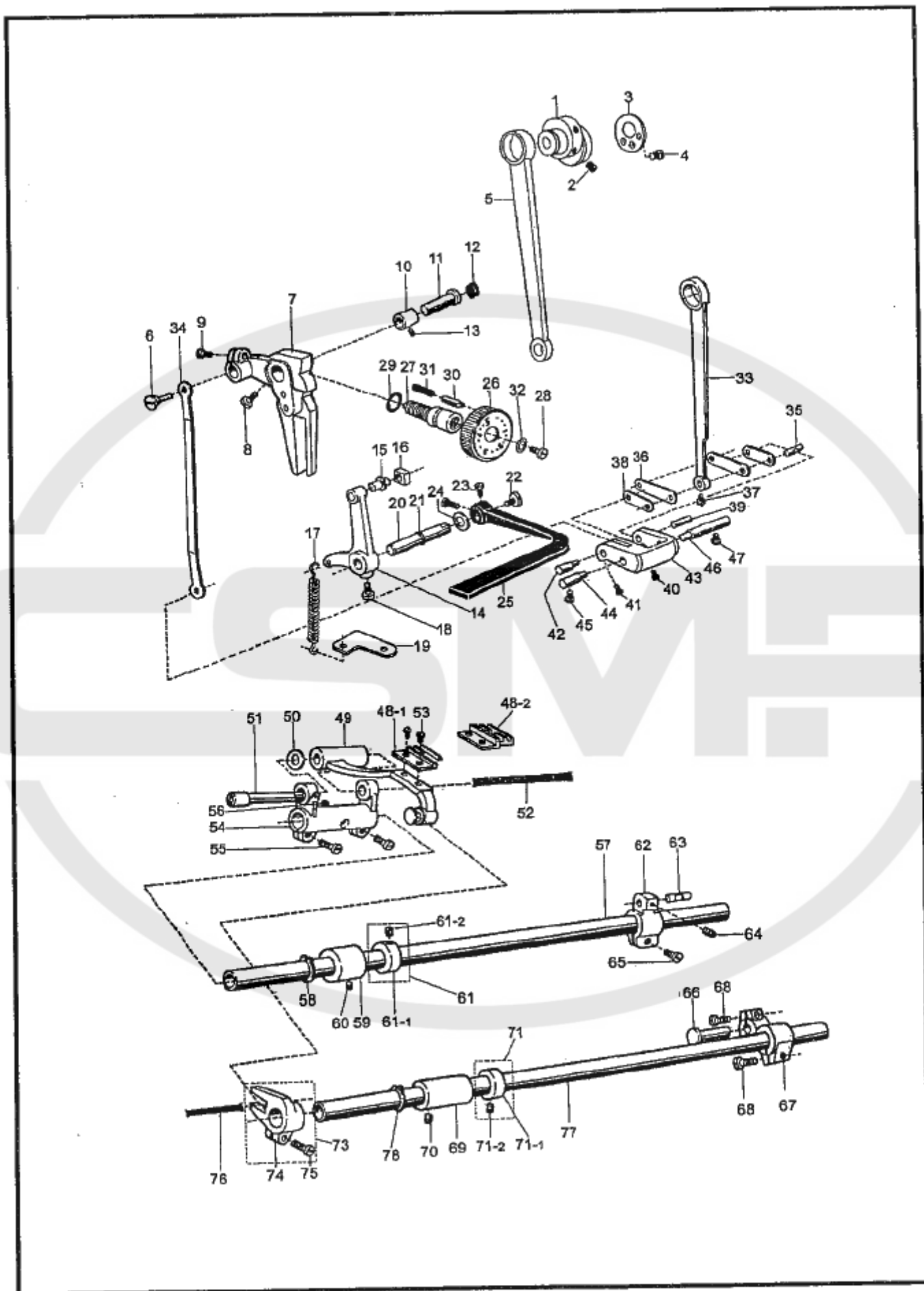

E. 送り関係/Feed mechanism/Transportvorrichtung/Mécanisme de l'entraînement/
Mecanismo de la alimentación

REF. NO.	CODE	Q'TY	ヒンメイ	NAME OF PARTS	RM
60	SW5049001	1	トメネジ5.95×28×4.5	SET SCREW, SM 5.95-28×4.5	
61	SW5178001	1	オクリジクセットカラークミ	SET SCREW COLLAR ASSY	
61-1	SW5179001	1	オクリジクセットカラー	SET SCREW COLLAR	
61-2	SW5180001	2	トメネジ6.35×40×4	SET SCREW, SM 6.35-40×4	
62	SW5181001	1	スイヘイオクリウデ	FEED ROCKER ARM	
63	SW5182001	1	スイヘイオクリウデジク	SHAFT, ;F-ROCKER ARM	
64	SW5152001	1	トメネジ4.37×40×7	SET SCREW, SM 4.37-40×7	
65	SW5162001	1	シメネジ4.37×40×12	SET SCREW, SM 4.37-40×12	
66	SW5184001	1	ジヨウゲオクリウデジク	SHAFT, ;V-FEEDING ARM	
67	SW5185001	1	ジヨウゲオクリウデ	V-FEEDING ARM	
68	SW5186001	2	シメネジ4.76×28×15	SCREW, SM 4.76-28×15	
69	SW5187001	1	メタル	BUSH	
70	SW5041001	1	トメネジ5.95×28×10	SET SCREW, SM 5.95-28×10	
71	SW5188001	1	オクリジクセットカラークミ	SET SCREW COLLAR ASSY	
71-1	SW5189001	1	オクリジクセットカラー	SET SCREW, COLLAR	
71-2	SW5068001	2	トメネジ6.35×40×4	SET SCREW, SM 6.35-40×4	
72	SW5190001	1	オクリジクスラストリング	RING, THRUST	
73	SW5191001	1	ジヨウゲオクリウデクミ	V-FEEDING ARM ASSY	
74	SW5192001	1	ジヨウゲオクリウデ	V-FEEDING ARM	
75	SW5160001	1	トメネジ4.37×40×12	SET SCREW, SM 4.37-40×12	
76	SW5197001	1	クミヒモ	WICK	
77	SW5198001	1	ジヨウゲオクリジク	SHAFT, ;V-FEEDING	
78	SW5176001	1	トメワジクヨウ	RETAINING RING, CEXTERNAL	

F. カマ関係/Rotary hook mechanism/Greifervorrichtung/Mécanisme du crochet rotatif/
 Mecanismo del cangrejo

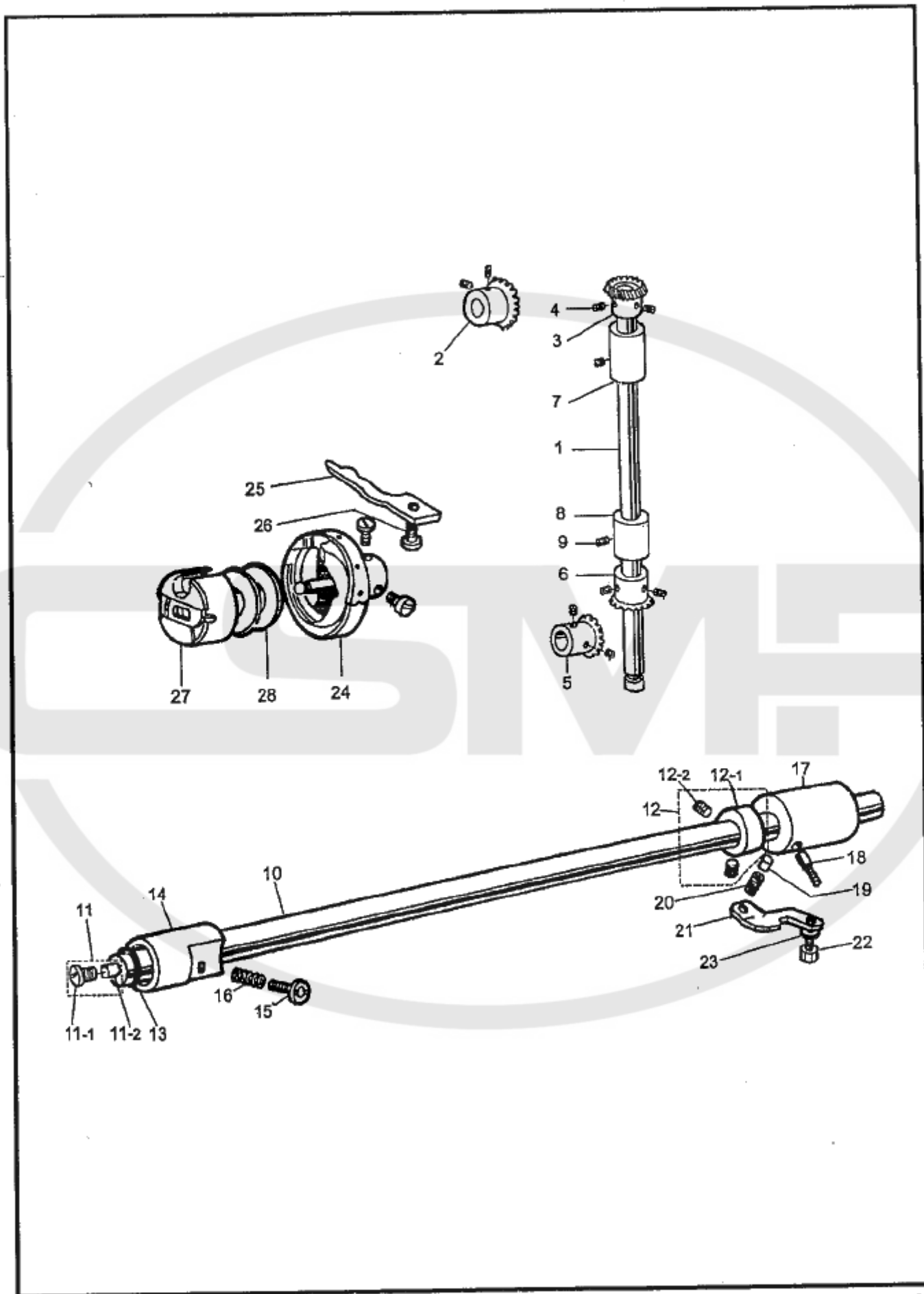

877-734-301

F. カマ関係/Rotary hook mechanism/Greifervorrichtung/Mécanisme du crochet rotatif/
Mecanismo del cangrejo

REF. NO.	CODE	Q'TY	ヒンメイ	NAME OF PARTS	RM
1	SW5209001	1	タテジク	VERTICAL SHAFT	
2	SW5210001	1	ウワジクベベルギヤ	BEVEL GEAR, ;U - SHAFT	
3	SW5211001	1	タテジクベベルギヤU	BEVEL GEAR, U; U - SHAFT	
4	SW5045001	1	アナトメネジ6.35×40×7	SET SCREW, SOCKET SM 6.35 - 40×7	
5	SW5213001	1	シタジクベベルギヤ	BEVEL GEAR, ;L - SHAFT	
6	SW5214001	1	タテジクベベルギヤD	BEVEL GEAR, D; V - SHAFT	
7	SW5215001	1	タテジクメタルUD	BUSH, UD; V - SHAFT	
8	SW5215001	1	タテジクメタルUD	BUSH, UD; V - SHAFT	
9	SW5041001	1	トメネジ5.95×28×10	SET SCREW, SM 5.95 - 28×10	
10	SW5216001	1	シタジク	LOWER SHAFT	
11	SW5217001	1	フェルトクミ	FELT ASSY	
11-1	SW5218001	1	ネジ4.76×32×9	SCREW, SM 4.76 - 32×9	
11-2	SW5219001	1	フェルト	FELT	
12	SW5220001	1	セットカラークミ	SET SCREW COLLAR ASSY	
12-1	SW5221001	1	セットカラー	SET SCREW COLLAR	
12-2	SW5049001	1	トメネジ5.95×28×4.5	SET SCREW, SM 5.95 - 28×4.5	
13	SW5222001	1	シタジクオイルシール	OIL SEAL, ;L - SHAFT	
14	SW5223001	1	シタジクメタルL	BUSH, L; L - SHAFT	
15	SW5224001	1	ネジ5.95×28×23.5	SCREW, SM 5.95 - 28×23.5	
16	SW5225001	1	オシバネ	SPRING, COMPRESSION	
17	SW5226001	1	シタジクメタルR	BUSH, R; L - SHAFT	
18	SW5227001	1	オイルチューブD	OL TUBE, D	
19	SW5228001	1	プランジセー	PLUNGER	
20	SW5229001	1	プランジセーバネ	SPRING, COMPRESSION	
21	SW5230001	1	バネオサエイタ	SPRING HOLDER	
22	SW5231001	1	シメネジ5.95×28×8	SCREW, SM 5.95 - 28×8	
23	SW5232001	1	バネザガネ	WASHAER, SPRING	
24	159907901	1	コウソクカマBハコクミ	ROTARY HOOK ASSY, B W/BOX	
25	SW5234001	1	ウチカマトメ	B - CASE HOLDER POSITION BRACKET	
26	SW5235001	1	シメネジ4.37×40×10	SCREW, SM 4.37 - 40×10	
27	S06573021	1	ボゼンケースクミ	BOBBIN CASE ASSY	
28	146290021	1	ボゼン	BOBBIN	

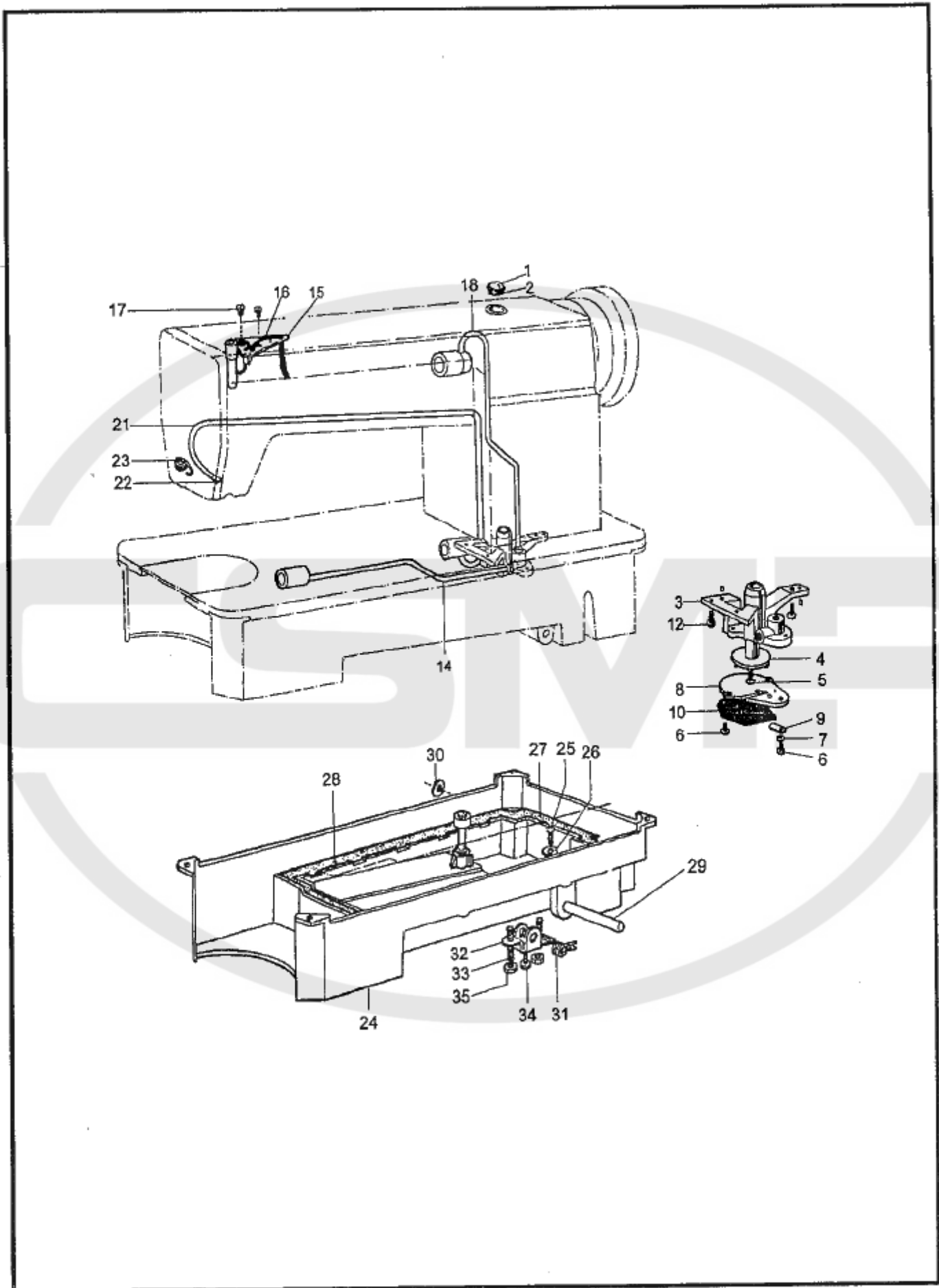

G. 給油潤滑関係/Lubrication/Schmierung/Lubrification/Lubricación

REF. NO.	CODE	Q'TY	ヒンメイ	NAME OF PARTS	RM
1	SW5238001	1	ユリヨウケイマド	OIL GAUGE WINDOW	
2	SW5239001	1	Oリング	O RING	
3	SW5240001	1	ポンプタイ	PUMP BODY	
4	SW5241001	1	ポンプカイテンヨク	PUMP PROPELLER	
5	SW5242001	1	シメネジ3.18×44×8	SCREW, SM 3.18-44×8	
6	SW5243001	3	ネジ3.18×44×13	SCREW, SM 3.18-44×13	
7	SW5244001	1	ザガネ	WASHER, PLAIN	
8	SW5245001	1	ポンプキヤク	PUMP SUPPORT	
9	SW5246001	1	フィルターバネ	SPRING	
10	SW5247001	1	ポンプファイル		
11	SW5248001	1	ポンプフィルター	FILTER, ; PUMP	
12	SW5231001	3	シメネジ5.95×28×8	SCREW, SM 5.95-28×8	
13	SW5249001	1	ジョイント	JOINT	
14	SW5250001	1	オイルチューブD	OIL TUBE, D	
15	SW5251001	1	クミヒモホルダ	HOLDER	
16	SW5252001	2	クミヒモ	WICK	
17	SW5253001	2	シメネジ3.57×40×11	SCREW, SM 3.57-40×11	
18	SW5254001	1	オイルチューブクミU	OIL TUBE ASSY, U	
21	SW5257001	1	チューフ	OIL TUBE	
22	SW5258001	1	フェルト	FELT	
23	SW5259001	1	チューブホルダ	TUBE HOLDER	
24	SW5260001	1	オイルパン	OIL PAN	
25	SW5261001	1	シメネジ7.94×28×10	SCREW, SM 7.94-28×10	
26	SW5262001	2	Oリング	O RING	
27	SW5263001	1	オイルシールS	OIL SEAL, S	
28	SW5264001	1	オイルシールL	OIL SEAL, L	
29	SW5265001	1	ヒザアゲヨコシク	LIFTER SHAFT, ; KNEE	
30	SW5266001	1	トメワ	RETAINING RING, E	
31	SW5267001	1	ヒザアゲネジリバネ	SPRING, TWIST	
32	SW5268001	1	ヒザアゲ	KNEE LIFTER	
33	SW5269001	1	シメネジ5.95×28×12	SCREW, SM 5.95-28×12	
34	SW5270001	2	トメネジ5.95×28×28	SCREW, SM 5.95-28×28	
35	SW5271001	2	ナツト	NUT	

H. 糸通シ関係/Threading mechanism/FadenführungsVorrichtung/Mécanisme de l'enfilage/
Mecanismo del enhebrado

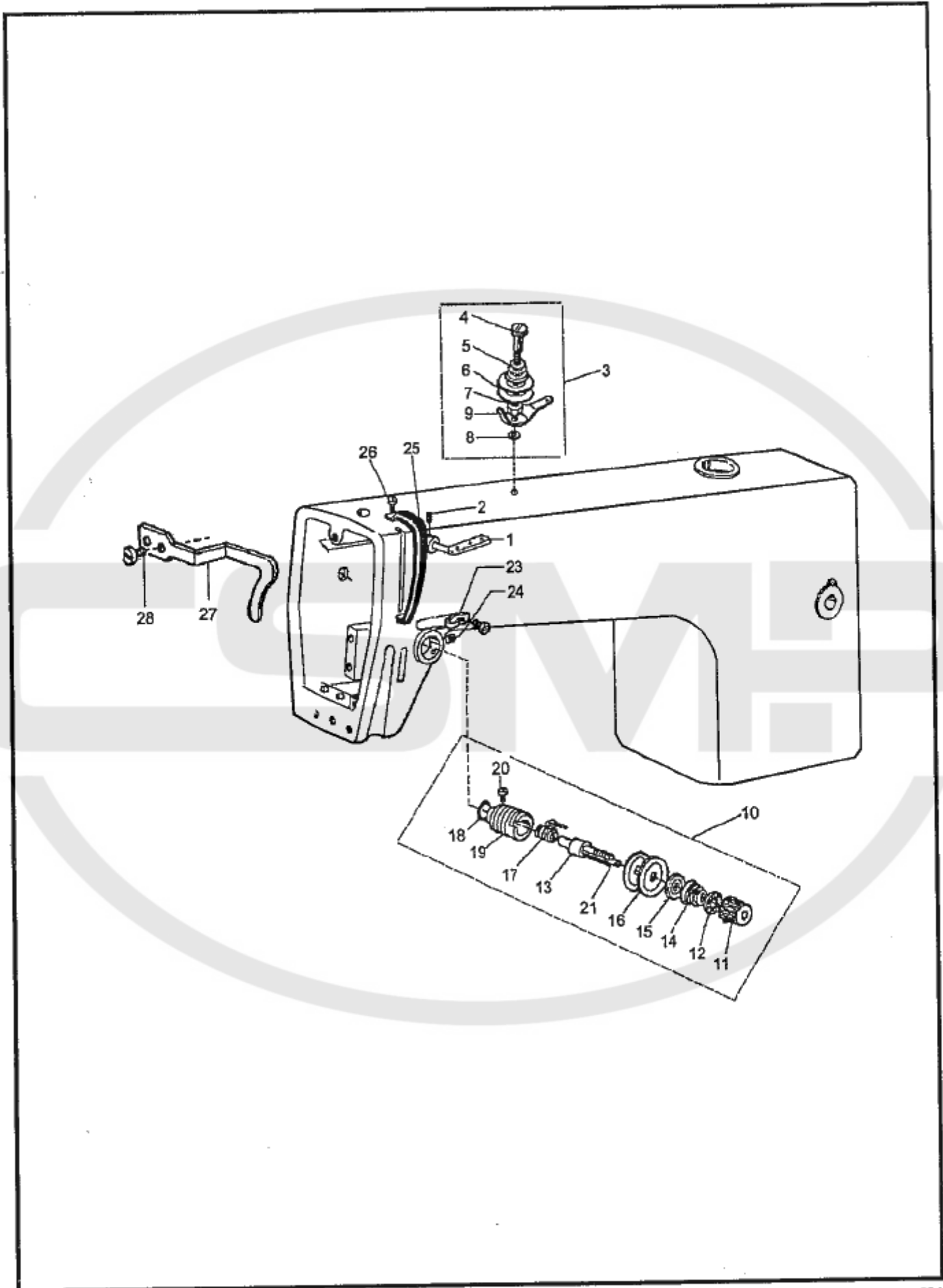

877-734-401

H. 糸通シ関係/Threading mechanism/FadenführungsVorrichtung/Mécanisme de l'enfilage/
Mecanismo del enhebrado

REF. NO.	CODE	Q'TY	ヒンメイ	NAME OF PARTS	RM
1	SW5272001	1	シツメイトカケ	THREAD RETAINER	
2	SW5273001	1	トメネジ4.37×40×10	SET SCREW, SM 4.37-40×10	
3	SW5274001	1	プレテンションクミ	PRE-TENSION ASSY	
4	SW5275001	1	イトアンナイチヨウシボウ	PRE-TENSION STUD	
5	SW5276001	1	プレテンションバネ	SPRING	
6	SW5277001	2	イトアンナイサラ	DISK, ; TR-GUIDE	
7	SW5278001	1	ナツト	NUT	
8	SW5266001	1	トメワ	RETAINING RING, E	
9	SW5279001	1	イトアンナイ	THREAD GUIDE	
10	SW5280001	1	イトチヨウシボウダイクミ	THREAD TENSION BRACKET ASSY	
11	SW5281001	1	イトチヨウシナツト	NUT, ; TENSION	
12	SW5282001	1	チヨウシバネウエザガネ	WASHER	
13	SW5283001	1	イトチヨウシボウ	TENSION STUD	
14	SW5284001	1	イトチヨウシバネ	TENSION SPRING	
15	SW5285001	1	イトチヨウシサラオサエ	DISK PRESSER, ; TENSION	
16	SW5286001	2	イトチヨウシサラ	TENSION DISK	
17	SW5287001	1	イトトリバネ	THREAD TAKE-UP SPRING	
18	SW5288001	1	Oリング	O RING	
19	SW5289001	1	イトチヨウシボウタイ	THREAD TENSION BRACKET	
20	SW5290001	1	イトネジ3.57×40×4	SCREW, SM 3.57-40×4	
21	SW5291001	1	イトユルメピン	PIN	
22	SW5107001	1	ボルト5.95×28×8	BOLT, SM 5.95-28×8	
23	SW5292001	1	アームイトアンナイ	THREAD GUIDE, ; ARM	
24	SW5013001	1	シメネジ3.57×40×6	SCREW, SM 3.57-40×6	
25	S02614001	1	テンピンカバー	COVER, ; T/TAKE-UP LEVER	
26	SW5294001	1	シメネジ4.37×40×5.5	SCREW, SM 4.37-40×5.5	
27	SW5295001	1	オサエボウダキイトアンナイ	THREAD GUIDE, ; P-BAR GUIDE	
28	SW5294001	1	シメネジ4.37×40×5.5	SCREW, SM 4.37-40×5.5	

Z. 付属品関係/Accessories/Zubehör/Accessoires/Accesorios

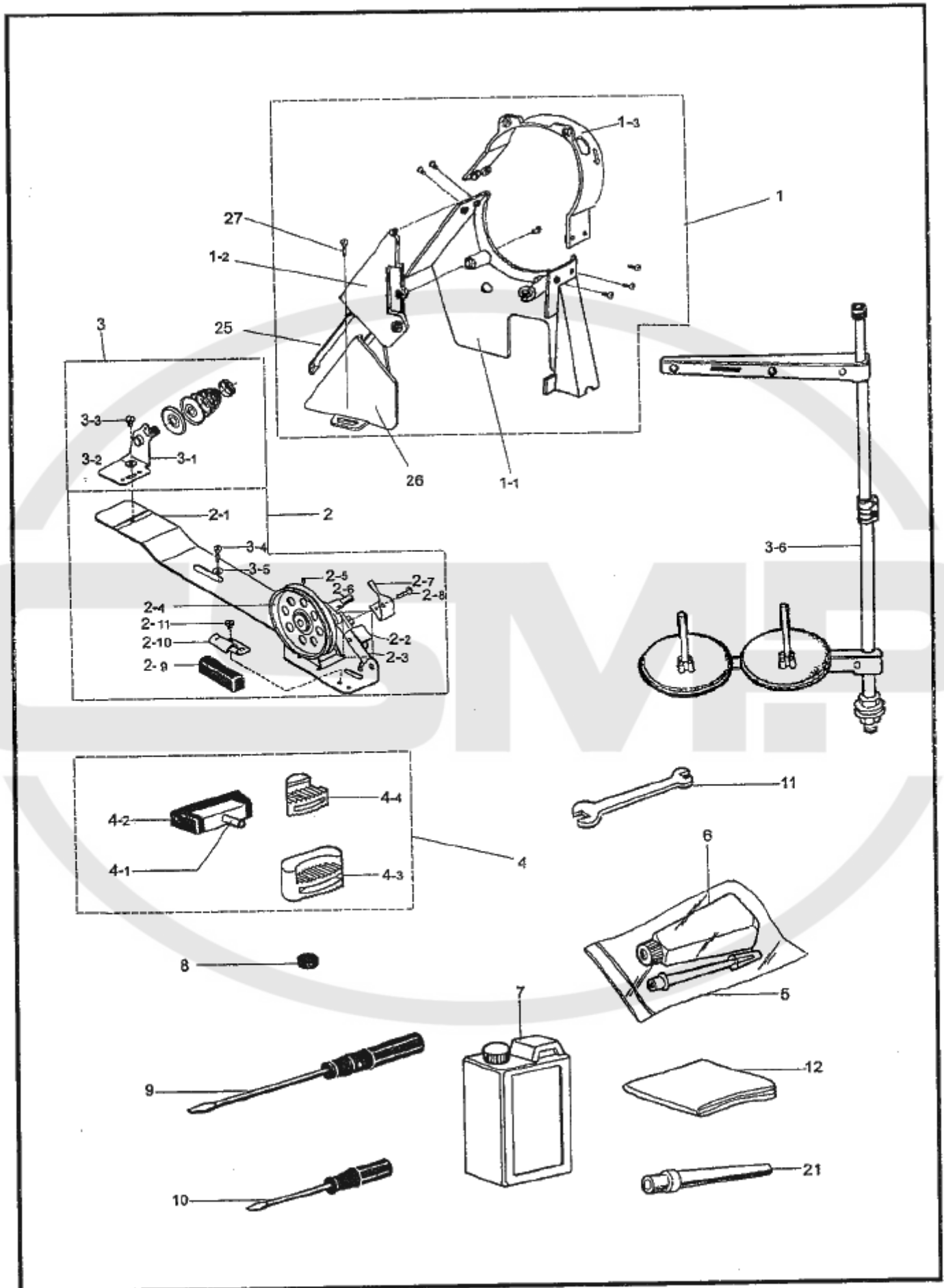

877-734-910

Z. 付属品関係/Accessories/Zubehör/Accessoires/Accesorios

REF. NO.	CODE	Q'TY	ヒンメイ	NAME OF PARTS	RM
1	SW5296001	1	ベルトカバークミ	BELT COVER ASSY	
1-1	SW5297001	1	ベルトカバータイ	BELT COVER, D	
1-2	SW5298001	1	ベルトカバーイタ	BELT COVER	
1-3	SW5301001	1	ベルトカバーU	BELT COVER, U	
2	SW5299001	1	イトマキクミ	BOBBIN WINDER ASSY	
2-1	SW5300001	1	イトマキキ	BOBBIN WINDER	
2-2	SW5305001	1	ボビンオサエダイクミ	BOBBIN PRESSER BRACKET ASSY	
2-3	SW5306001	1	ボビンオサエダイ	BOBBIN PRESSER BRACKER	
2-4	SW5309001	1	イトマキクルマ	WHEEL, ; B - WINDER	
2-5	SW5310001	1	シメネジ4.37×40×6.5	SCREW, SM 4.37 - 40×6.5	
2-6	SW5311001	1	イトマキジク	SHAFT, ; B - WINDER	
2-7	SW5312001	1	ボビンオサエ	PRESSER, ; BOBBIN	
2-8	SW5313001	1	トメネジ3.18×44×13	SET SCREW, SM 3.18 - 44×13	
2-9	SW5314001	1	イトマキクルマカイトンドメ	STOPPER, ; B - WINDER WHEEL	
2-10	SW5315001	1	カイトンドメオサエ	HOLDER, ; STOPPER	
2-11	SW5316001	1	シメネジ4.37×40×3.5	SCREW, SM 4.37 - 40×3.5	
3	SW5317001	1	イトタテダイクミ	COTTON STAND ASSY	
3-1	SW5318001	1	スレツドハンガークミ	THREAD HANGER ASSY	
3-2	SW5319001	1	ザガネ	WASHER, PLAIN	
3-3	SW5294001	1	シメネジ4.37×40×5.5	SCREW, SM 4.37 - 40×5.5	
3-4	SW5320001	2	マルモクネジM5×25	WOOD SCREW, M 5×25	
3-5	SW5321001	2	ザガネ	WASHER, PLAIN	
3-6	SW5322001	1	イトタテダイクミ	COTTON STAND ASSY	
4	SW5323001	2	ラバーヒンジクミ	HINGE ASSY, ; RUBBER	
4-1	SW5324001	2	トウブヒンジ	HEAD HINGE	
4-2	SW5325001	2	トウブヒンジウケゴム	RUBBER CUSHION	
4-3	SW5326001	2	トウブシキゴムL	HEAD CUSHION, L	
4-4	SW5327001	2	トウブシキゴムS	HEAD CUSHION, S	
5	SW5328001	1	フソクヒンポリフクロ	ACCESSORY BAG, ; PE	
6	SW5329001	1	オイルタンクS	OIL TANK, S	
7	SW5330001	1	オイルタンクL	OIL TANK, L	
8	SW5331001	1	シユウジンマグネット	MAGNET	
9	SW5332001	1	ネジマワシL	SCREW DRIVER, L	
10	SW5333001	1	ネジマワシS	SCREW DRIVER, S	
11	SW5334001	1	スパナ	WRENCH	
12	SW5335001	1	ミシンポリフクロ	HEAD COVER	
21	100477029	1	マクラ	HEAD REST	
25	SW5302001	1	ベルトカバー DフタS	LID, S; B - COVER	
26	SW5349001	1	ベルトカバー D	BELT COVER, D	
27	SW5320001	1	マルモクネジM5×25	WOOD SCREW, M 5×25	

877-734-910

© 付属品の明細は変更することがあります。



© The details of included accessories are subject to change.

© Änderungen in der Aufstellung der Mitgelieferten Zubehöre sind vorbehalten.

© Les détails des accessoires inclus sont sujets à des changements.

© Los detalles de accesorios incluidos pueden variar.

Wa 警告ラベル/Warning labels/Warnschilder/Etiquettes d'avertissement/
Etiquetas de advertencia

警告ラベル/Warning labels	品名/Name of parts	Size(mm)	Code
	Label,operation Eng.	40 × 64	S38349 - 001
	アースマーク Label,grounding	Φ12	S37060 - 001

CSTMP

索引 / INDEX / VERZEICHNIS /

INDEX / INDICE

CODE	REF. NO.	Page	CODE	REF. NO.	Page	CODE	REF. NO.	Page
SW5008001	A -3	2	SW5074001	C -33	4	SW5139001	E -24	8
SW5009001	A -4	2	SW5075001	C -34	4	SW5140001	E -25	8
SW5010001	A -5	2	SW5078001	C -35	4	SW5141001	E -26	8
	A -16	2	SW5079001	C -35-1	4	SW5142001	E -27	8
SW5011001	A -6	2	SW5080001	C -35-2	4	SW5143001	E -28	8
SW5012001	A -7	2	SW5081001	C -36	4	SW5144001	E -29	8
SW5013001	A -8	2	SW5082001	C -37-1	4	SW5145001	E -30	8
	H -24	16	SW5083001	C -38	4	SW5146001	E -31	8
SW5014001	A -9	2	SW5084001	C -39	4	SW5148001	E -33	8
SW5015001	A -10	2	SW5085001	C -39-1	4	SW5149001	E -34	8
SW5016001	A -11	2	SW5086001	C -39-2	4	SW5150001	E -35	8
SW5017001	A -12	2	SW5087001	C -39-3	4	SW5151001	E -36	8
	D -2	6	SW5088001	D -1	6	SW5152001	E -37	8
	Z -1-3	18	SW5089001	D -3	6		E -64	10
SW5018001	A -13	2	SW5090001	D -4	6	SW5153001	E -38	8
SW5019001	A -14	2	SW5091001	D -5	6	SW5154001	E -39	8
SW5020001	A -15	2	SW5092001	D -6	6	SW5155001	E -40	8
SW5021001	A -19	2	SW5093001	D -7	6	SW5156001	E -41	8
SW5022001	A -20	2	SW5094001	D -8	6	SW5157001	E -42	8
SW5023001	A -21	2	SW5095001	D -9	6	SW5158001	E -43	8
SW5024001	A -22	2	SW5096001	D -10	6	SW5159001	E -44	8
SW5025001	C -1	4		D -14	6	SW5160001	E -45	8
SW5031001	C -2	4	SW5097001	D -11	6		E -47	8
SW5038001	C -3	4	SW5098001	D -12	6		E -75	10
SW5041001	C -5	4	SW5099001	D -13	6	SW5161001	E -46	8
	C -32	4		E -21	8	SW5162001	E -65	10
	E -13	8	SW5100001	C -37-2	4	SW5163001	E -48-1	8
	E -70	10	SW5101001	D -15	6	SW5164001	E -49	8
	F -9	12	SW5102001	D -16	6	SW5165001	E -48-2	8
SW5043001	C -6	4	SW5103001	D -17	6	SW5169001	E -50	8
SW5044001	C -7	4	SW5104001	D -18	6	SW5170001	E -51	8
SW5045001	C -8	4	SW5105001	D -19	6	SW5171001	E -52	8
	F -4	12	SW5106001	D -20	6	SW5172001	E -53	8
SW5046001	C -9	4	SW5107001	D -21	6	SW5173001	E -54	8
SW5047001	C -10	4		E -2	8	SW5174001	E -55	8
SW5048001	C -11	4		H -22	16	SW5175001	E -57	8
SW5049001	C -12	4	SW5108001	D -22	6	SW5176001	E -58	8
	E -60	10	SW5109001	D -23	6		E -78	10
	F -12-2	12	SW5110001	D -24	6	SW5177001	E -59	8
SW5050001	C -13	4	SW5111001	D -25	6	SW5178001	E -61	10
SW5051001	C -14	4	SW5112001	D -26	6	SW5179001	E -61-1	10
SW5052001	C -15	4	SW5113001	D -27-1	6	SW5180001	E -61-2	10
SW5053001	C -16	4	SW5114001	D -27-2	6	SW5181001	E -62	10
SW5054001	C -17-1	4	SW5118001	D -28	6	SW5182001	E -63	10
SW5055001	C -18	4	SW5119001	E -1	8	SW5184001	E -66	10
SW5056001	C -17-2	4	SW5120001	E -3	8	SW5185001	E -67	10
SW5057001	C -20	4	SW5121001	E -4	8	SW5186001	E -68	10
SW5058001	C -21	4	SW5122001	E -5	8	SW5187001	E -69	10
SW5059001	C -22	4	SW5123001	E -6	8	SW5188001	E -71	10
	E -9	8	SW5124001	E -7	8	SW5189001	E -71-1	10
	E -56	8	SW5125001	E -8	8	SW5190001	E -72	10
				E -23	8	SW5191001	E -73	10
SW5060001	C -23	4	SW5126001	E -10	8	SW5192001	E -74	10
SW5062001	C -24	4	SW5127001	E -11	8	SW5197001	E -76	10
SW5063001	C -25	4	SW5128001	E -12	8	SW5198001	E -77	10
SW5064001	C -26	4	SW5129001	E -14	8	SW5200001	B -1	2
SW5065001	C -27	4	SW5130001	E -15	8	SW5201001	B -1-1	2
SW5066001	C -28	4	SW5131001	E -16	8	SW5202001	B -1-2	2
SW5067001	C -28-1	4	SW5132001	E -17	8	SW5203001	B -1-3	2
SW5068001	C -28-2	4	SW5133001	E -18	8	SW5204001	B -1-4	2
	E -71-2	10	SW5134001	E -19	8	SW5205001	B -1-5	2
SW5070001	C -29	4	SW5135001	E -20	8	SW5206001	B -1-6	2
SW5071001	C -30	4	SW5137001	E -22	8	SW5207001	B -1-7	2
SW5072001	C -31	4						

CODE	REF. NO.	Page	CODE	REF. NO.	Page	CODE	REF. NO.	Page
SW5208001	B -1-8	2	SW5273001	H -2	16	S02614001	H -25	16
SW5209001	F -1	12	SW5274001	H -3	16	S06573021	F -27	12
SW5210001	F -2	12	SW5275001	H -4	16	S37060001	Wa	19
SW5211001	F -3	12	SW5276001	H -5	16	S38349001	Wa	19
SW5213001	F -5	12	SW5277001	H -6	16	100265034	C -19-1	4
SW5214001	F -6	12	SW5278001	H -7	16	100477029	Z -21	18
SW5215001	F -7	12	SW5279001	H -9	16	107415014	C -19-2	4
	F -8	12	SW5280001	H -10	16	146290021	F -28	12
SW5216001	F -10	12	SW5281001	H -11	16	159907901	F -24	12
SW5217001	F -11	12	SW5282001	H -12	16			
SW5218001	F -11-1	12	SW5283001	H -13	16			
SW5219001	F -11-2	12	SW5284001	H -14	16			
SW5220001	F -12	12	SW5285001	H -15	16			
SW5221001	F -12-1	12	SW5286001	H -16	16			
SW5222001	F -13	12	SW5287001	H -17	16			
SW5223001	F -14	12	SW5288001	H -18	16			
SW5224001	F -15	12	SW5289001	H -19	16			
SW5225001	F -16	12	SW5290001	H -20	16			
SW5226001	F -17	12	SW5291001	H -21	16			
SW5227001	F -18	12	SW5292001	H -23	16			
SW5228001	F -19	12	SW5294001	H -26	16			
SW5229001	F -20	12		H -28	16			
SW5230001	F -21	12		Z -3-3	18			
SW5231001	F -22	12	SW5295001	H -27	16			
	G -12	14	SW5296001	Z -1	18			
	Z -1-4	18	SW5297001	Z -1-1	18			
SW5232001	F -23	12	SW5298001	Z -1-2	18			
SW5234001	F -25	12	SW5299001	Z -2	18			
SW5235001	F -26	12	SW5300001	Z -2-1	18			
SW5238001	G -1	14	SW5301001	Z -1-5	18			
SW5239001	G -2	14	SW5302001	Z -25	18			
SW5240001	G -3	14	SW5305001	Z -2-2	18			
SW5241001	G -4	14	SW5306001	Z -2-3	18			
SW5242001	G -5	14	SW5307001	Z -2-4	18			
SW5243001	G -6	14	SW5309001	Z -2-5	18			
SW5244001	G -7	14	SW5310001	Z -2-6	18			
SW5245001	G -8	14	SW5311001	Z -2-7	18			
SW5246001	G -9	14	SW5312001	Z -2-8	18			
SW5247001	G -10	14	SW5313001	Z -2-9	18			
SW5248001	G -11	14	SW5314001	Z -2-10	18			
SW5249001	G -13	14	SW5315001	Z -2-11	18			
SW5250001	G -14	14	SW5316001	Z -2-12	18			
SW5251001	G -15	14	SW5317001	Z -3	18			
SW5252001	G -16	14	SW5318001	Z -3-1	18			
SW5253001	G -17	14	SW5319001	Z -3-2	18			
SW5254001	G -18	14	SW5320001	Z -3-4	18			
SW5257001	G -21	14		Z -27	18			
SW5258001	G -22	14	SW5321001	Z -3-5	18			
SW5259001	G -23	14	SW5322001	Z -3-6	18			
SW5260001	G -24	14	SW5323001	Z -4	18			
SW5261001	G -25	14	SW5324001	Z -4-1	18			
SW5262001	G -26	14	SW5325001	Z -4-2	18			
SW5263001	G -27	14	SW5326001	Z -4-3	18			
SW5264001	G -28	14	SW5327001	Z -4-4	18			
SW5265001	G -29	14	SW5328001	Z -5	18			
SW5266001	G -30	14	SW5329001	Z -6	18			
	H -8	16	SW5330001	Z -7	18			
SW5267001	G -31	14	SW5331001	Z -8	18			
SW5268001	G -32	14	SW5332001	Z -9	18			
SW5269001	G -33	14	SW5333001	Z -10	18			
SW5270001	G -34	14	SW5334001	Z -11	18			
SW5271001	G -35	14	SW5335001	Z -12	18			
SW5272001	H -1	16	SW5349001	Z -26	18			

brother®

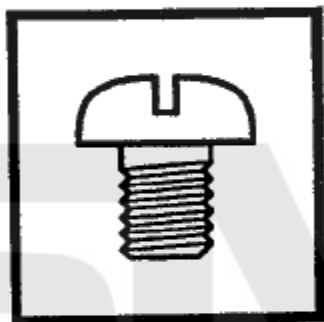

パーツブック
PARTS BOOK
TEILEKATALOG
LIVRE DES PIECES
LIBRO DE REFERENCIA DE PIEZAS

ブラザー工業株式会社

〒467-8561 名古屋市瑞穂区苗代町15番1号 TEL(052)824-2392

BROTHER INDUSTRIES, LTD.

15-1, Naeshiro-cho, Mizuho-ku, Nagoya 467-8561, Japan. Phone: 81-52-824-2177

Printed in Japan / Gedrukt in Japan / Imprimé au Japon / Impreso en Japón

877-734
S95734-101
2002.04.C(1)