

S-7300A

パーツブック
PARTS BOOK

電子本縫ダイレクトドライブ自動糸切りミシン
SINGLE NEEDLE DIRECT DRIVE LOCK STITCHER WITH
ELECTRONIC FEEDING SYSTEM AND THREAD TRIMMER

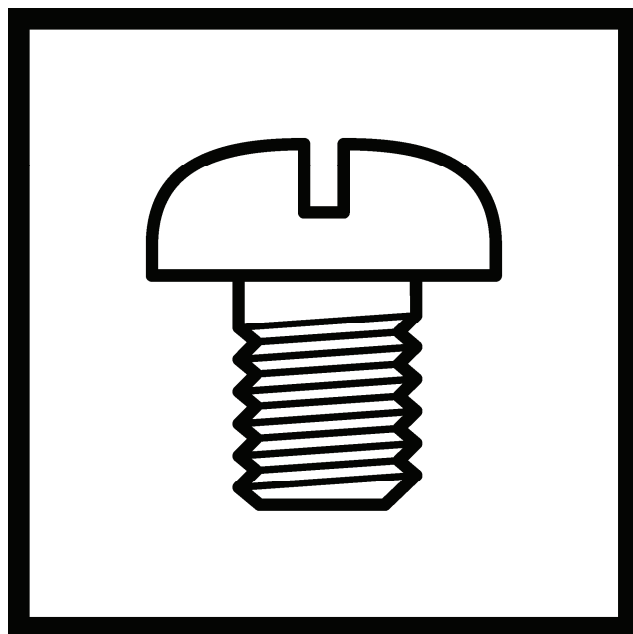

brother

最新の部品情報は Parts Navigation でご覧いただけます。 <http://partsbook.brother.co.jp/partsnavi/jpn/>
The latest parts information, refer to the Parts Navigation. <http://partsbook.brother.co.jp/partsnavi/eng/>

型式板の見方

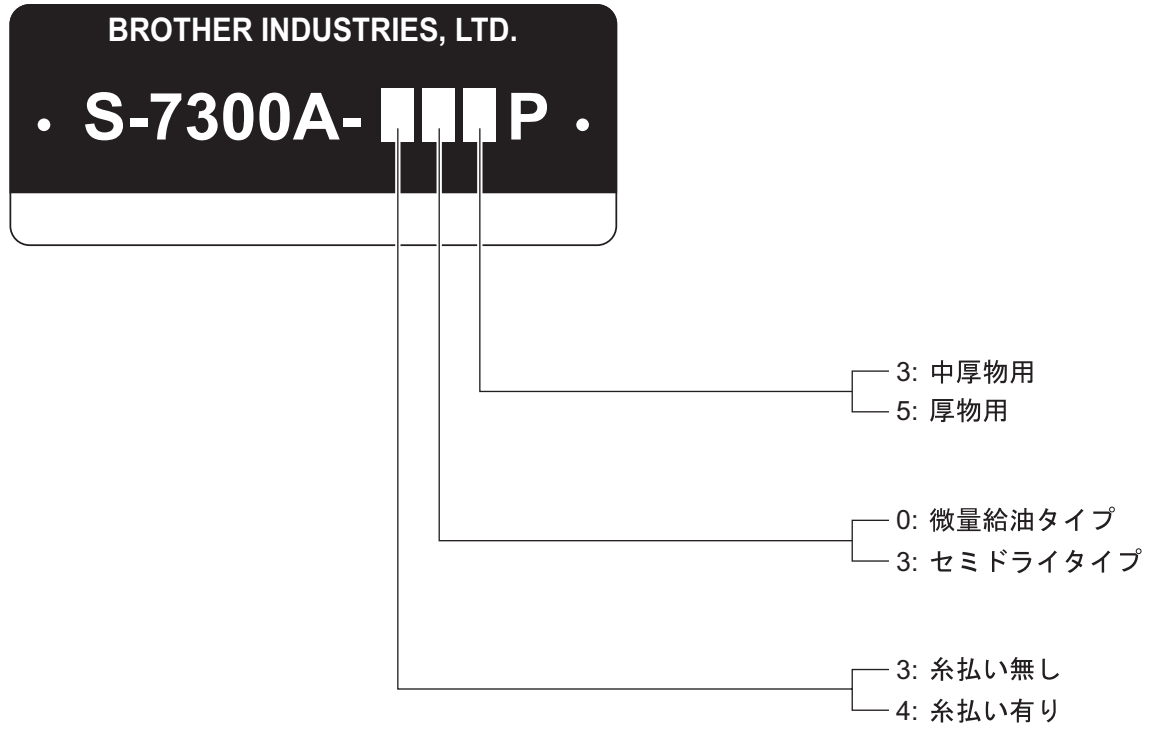

Description of model plate

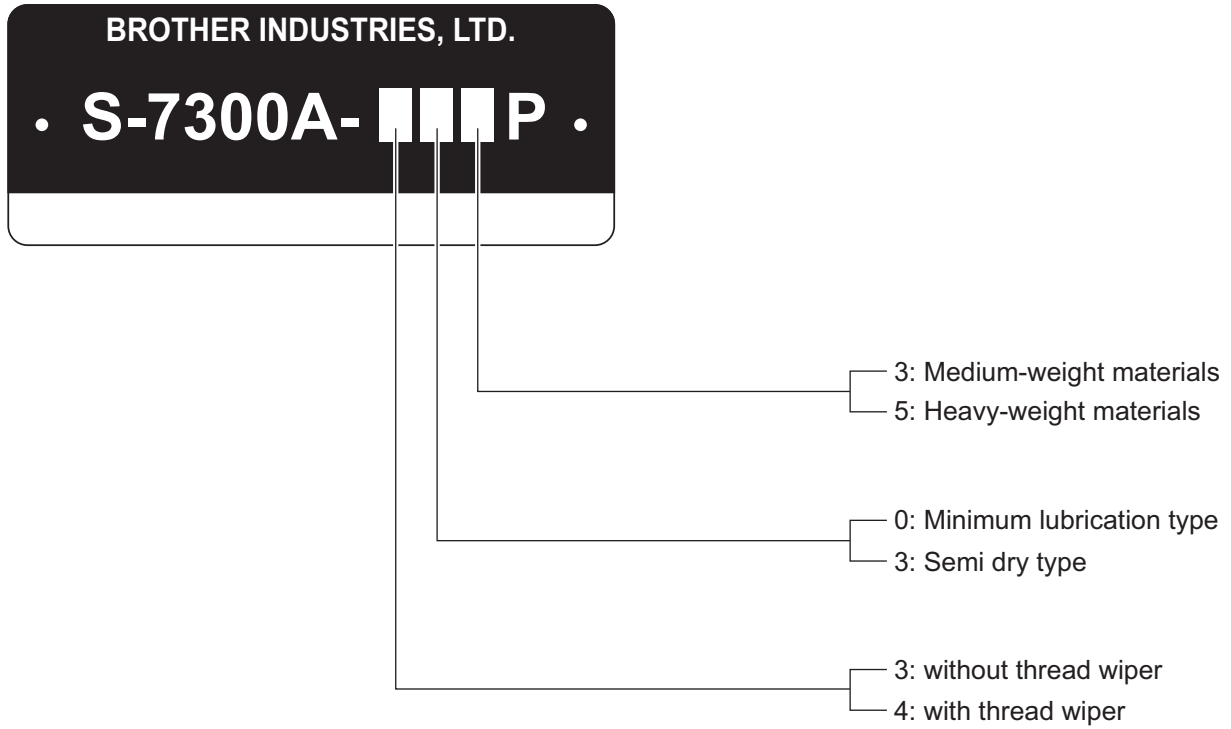

パーツブックご利用に際して

1. このリストは、2015年2月のデータに基づいて作成されたものです。
2. 部品は予告なしに設計変更される場合があります。
3. 組単位で補給する部品は、破線で示してあります。
4. イラスト中で数字(REF.NO)に“+”がついている部品は、仕様により異なります。
詳細は、リストを参照してください。

目 次

A. 主体関係	1	Sp3. 仕様別部品一覧表	
B. 針棒・天秤関係	3	(欧州向).....	51
C. 押え関係	7	Ga1. ゲージ部品一覧表	
D. 送り関係	11	(中厚物用:3枚歯).....	52
E. 膝上げ関係	13	Ga2. ゲージ部品一覧表	
F. かま関係	15	(中厚物用:3枚歯).....	53
G. 給油潤滑関係	17	Ga3. ゲージ部品一覧表	
H. 糸通し関係	19	(厚物用:3枚歯).....	54
J. 糸巻関係	23	Ga4. ゲージ部品一覧表	
K. 糸切り関係	25	(中厚物用:4枚歯).....	55
L. 糸緩め関係	29	Ga5. ゲージ部品一覧表	
M. 糸払い関係(-4□□用)	31	(中厚物用:4枚歯).....	56
N1. コントロールボックス関係	33	Ga6. ゲージ部品一覧表	
N2. コントロールボックス関係	37	(中厚物用:4枚歯).....	57
P. 逆転スイッチ関係	39	Ga7. ゲージ部品一覧表	
Q. モーターカバー関係	41	(厚物用:4枚歯).....	58
T. 操作パネル関係	43	Ga8. ゲージ部品一覧表	
U. モーター関係	45	(難素材・新素材用:4枚歯).....	59
V. 付属品関係	47	Wa. 警告ラベル	60
Sp1. 仕様別部品一覧表(日本向).....	49	索引	62
Sp2. 仕様別部品一覧表			
(米州向、中国向、輸出一般向).....	50		

Notes for using this parts book

1. This book was prepared based on information available in February 2015.
2. Parts are subject to changes in design without prior notice.
3. Parts supplied as complete assemblies are circled by a dotted line.
4. The part which has the symbol "+" on its number (REF.NO) in the figure differs depending on the specification. For details, refer to the parts list.

CONTENTS

A. Machine body	1	Sp3. Different parts list	
B. Needle bar and thread take-up mechanism ...	3	(For Europe)	51
C. Presser foot mechanism	7	Ga1. Gauge parts list	
D. Feed mechanism	11	(Medium-weight materials : 3ROW)	52
E. Knee lifter mechanism	13	Ga2. Gauge parts list	
F. Rotary hook mechanism	15	(Medium-weight materials : 3ROW)	53
G. Lubrication	17	Ga3. Gauge parts list	
H. Threading mechanism	19	(Heavy-weight materials : 3ROW)	54
J. Bobbin winder mechanism	23	Ga4. Gauge parts list	
K. Thread trimmer mechanism	25	(Medium-weight materials : 4ROW)	55
L. Tension release mechanism	29	Ga5. Gauge parts list	
M. Thread wiper mechanism (For -4[])	31	(Medium-weight materials : 4ROW)	56
N1. Control box	33	Ga6. Gauge parts list	
N2. Control box	37	(Medium-weight materials : 4ROW)	57
P. Quick reverse switch mechanism	39	Ga7. Gauge parts list	
Q. Motor cover	41	(Heavy-weight materials : 4ROW)	58
T. Operation panel	43	Ga8. Gauge parts list	
U. Motor mechanism	45	(Difficult-to-sew materials & Shin-gosen : 4ROW) ...	59
V. Accessories	47	Wa. Warning labels	60
Sp1. Different parts list (For Japan)	49	Index	62
Sp2. Different parts list			
(For the Americas, China and General export) ..	50		

A. 主体関係 / Machine body

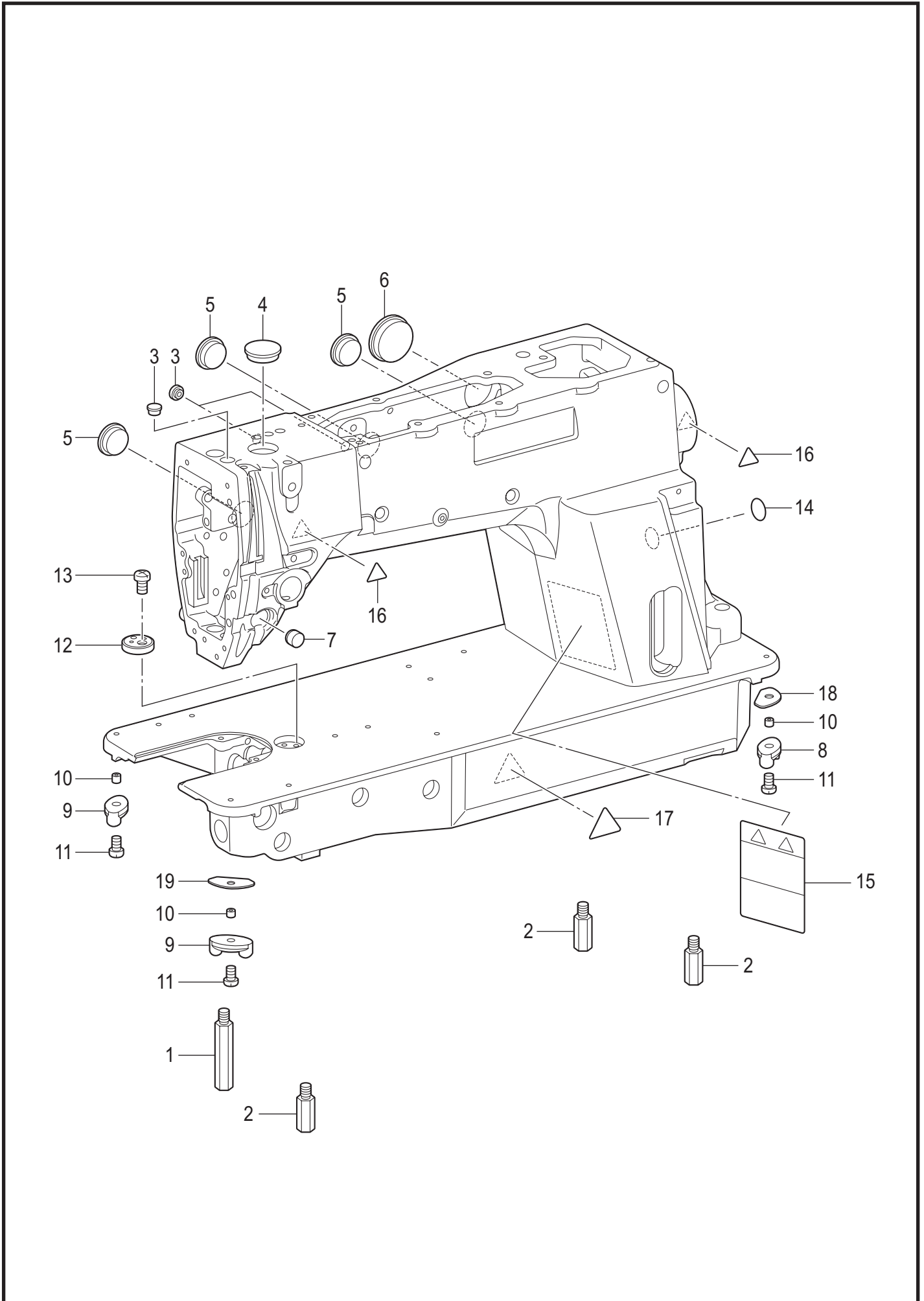

A. 主体関係 / Machine body

REF.NO	CODE	QTY	品名	NAME OF PARTS	RM
1	SB3440001	1	キャクチュウL	STAND L	
2	SB4845001	3	キャクチュウR	STAND R	
3	104450101	3	ゴムセン8	RUBBER CAP 8	
4	SA5810001	1	ゴムセン23.5	RUBBER CAP 23.5	
5	159150000	3	ゴムセン20.5	RUBBER CAP 20.5	
6	150607000	1	ゴムセン32.8	RUBBER CAP 32.8	
7	SB5043001	1	ゴムセン15.5	RUBBER CAP 15.5	
8	SB5638001	1	トウブシキゴムR	HEAD CUSHION R	
9	SB5044001	2	トウブシキゴムL	HEAD CUSHION L	
10	SB5312001	3	カラー4-5.3	COLLAR 4-5.3	
11	060401216	3	バインド4X12	SCREW BIND M4X12	
12	SB3850001	1	ジョウギイタ	RULER PLATE	
13	062400616	1	ナベコ4X6	SCREW PAN M4X6	
14	S37060001	1	ア-スマーク	LABEL, GROUNDING	
15	SA9826001	1	ソウサチュウイラベル	LABEL CAUTION	
16	SA9957001	2	ワ-ニングマ-ク	INJURY MARK	
17	SA9957002	1	ワ-ニングマ-ク	INJURY MARK	
18	SB6427001	1	スペーサ	SPACER	
19	SB6427001	1	スペーサ	SPACER	

B. 針棒・天秤關係 / Needle bar and thread take-up mechanism

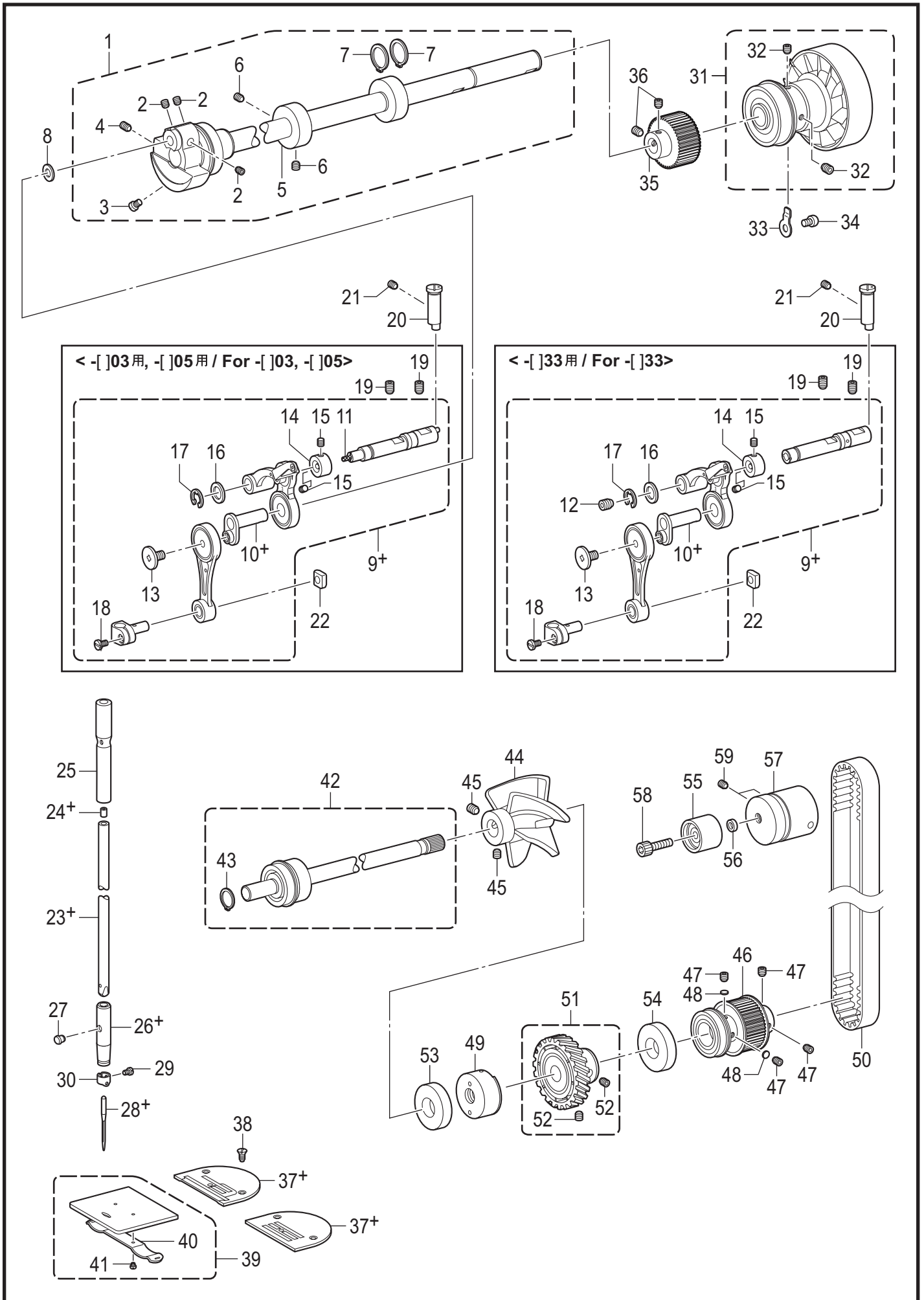

B. 針棒・天秤関係 / Needle bar and thread take-up mechanism

REF.NO	CODE	QTY	品名	NAME OF PARTS	RM
1	SB5290001	1	ウワジククミ	UPPER SHAFT ASSY	
2	S23651001	3	アナヒラ6X6ホソメ	SET SCREW SOCKET (FT) M6X6	
3	S25235001	1	シメネジ8	SCREW M8	
4	S25236001	1	アナヒラ6X10ホソメ	SET SCREW SOCKET (FT) M6X10	
5	SA1120001	1	イトマキクドウリン	BOBBIN WINDER DRIVING WHEEL	
6	S23651001	2	アナヒラ6X6ホソメ	SET SCREW SOCKET (FT) M6X6	
7	048150142	2	トメワジクヨウC15	RETAINING RING EXTERNAL C15	
8	110367001	1	ザガネ	WASHER, PLAIN SPECIAL 8	
			<-□03用>	<For -□03>	
9+	SB5248001	1	ハリボウレンカンソウクミ3	NEEDLE BAR CONNECTING ROD UNIT	
10+	SA7625001	1	ハリボウクランク	NEEDLE BAR CRANK	
11	S32958000	1	クミヒモ	WICK	
			<-□05用>	<For -□05>	
9+	SB5253001	1	ハリボウレンカンソウクミ5	NEEDLE BAR CONNECTING ROD UNIT	
10+	SA7626001	1	ハリボウクランク	NEEDLE BAR CRANK	
11	S32958000	1	クミヒモ	WICK	
			<-□33用>	<For -□33>	
9+	SB5252001	1	ハリボウレンカンソウクミ3D	NEEDLE BAR CONNECTING ROD UNIT	
10+	SA7625001	1	ハリボウクランク	NEEDLE BAR CRANK	
12	SA8061001	1	アナクボミ3X4シール	SET SCREW SOCKET(CP)M3X4 SEAL	
13	SA2422001	1	シメネジ3.57L	SCREW, SM3.57L	
14	SB3776001	1	セツカラー	SET SCREW COLLAR	
15	012400436	2	アナヒラ4X4	SET SCREW SOCKET (FT) M4X4	
16	SA2161001	1	ザガネ	WASHER	
17	048060342	1	トメワE6	RETAINING RING E6	
18	140004001	1	シメネジ3.57	SCREW, SM3.57-40X7	
19	012060636	2	アナヒラ6X6	SET SCREW SOCKET (FT) M6X6	
20	SA7239101	1	ストッパーピン	STOPPER PIN	
21	012500536	1	アナヒラ5X5	SET SCREW SOCKET (FT) M5X5	
22	102630001	1	ハリボウアンナイカクコマ	NEEDLE BAR GUIDE SLIDE BLOCK	
23+	*P.49-51	1	ハリボウ	NEEDLE BAR	
			<-□□3用>	<For -□□3>	
24+	S04630000	1	ハリボウセン	NEEDLE BAR CORK	
			<-□05用>	<For -□05>	
24+	111863001	1	ハリボウセン	NEEDLE BAR CORK	
25	SB5032001	1	ハリボウメタルU	NEEDLE BAR BUSH U	
			<-□□3用>	<For -□□3>	
26+	SA1138101	1	ハリボウメタルD	NEEDLE BAR BUSH D	
			<-□05用>	<For -□05>	
26+	SA1139101	1	ハリボウメタルD	NEEDLE BAR BUSH D	
27	104833001	1	ゴムセン4.3	RUBBER CAP 4.3	
28+	*P.49-51	1	ミシンハリ	NEEDLE	
29	140553102	1	アタマツキトメネジ3.18	SET SCREW, SM3.18	
30	151594001	1	ハリボウイトアンナイ	NEEDLE BAR THREAD GUIDE	
31	SB5318001	1	プーリクミ	PULLEY ASSY	
32	S23651001	2	アナヒラ6X6ホソメ	SET SCREW SOCKET (FT) M6X6	
33	SB5227001	1	ベアリングオサエ	BEARING HOLDER	
34	062500816	1	ナベコ5X8	SCREW PAN M5X8	
35	SB4849001	1	タイミングプーリU	TIMING PULLEY U	
36	S23651001	2	アナヒラ6X6ホソメ	SET SCREW SOCKET (FT) M6X6	

B. 針棒・天秤關係 / Needle bar and thread take-up mechanism

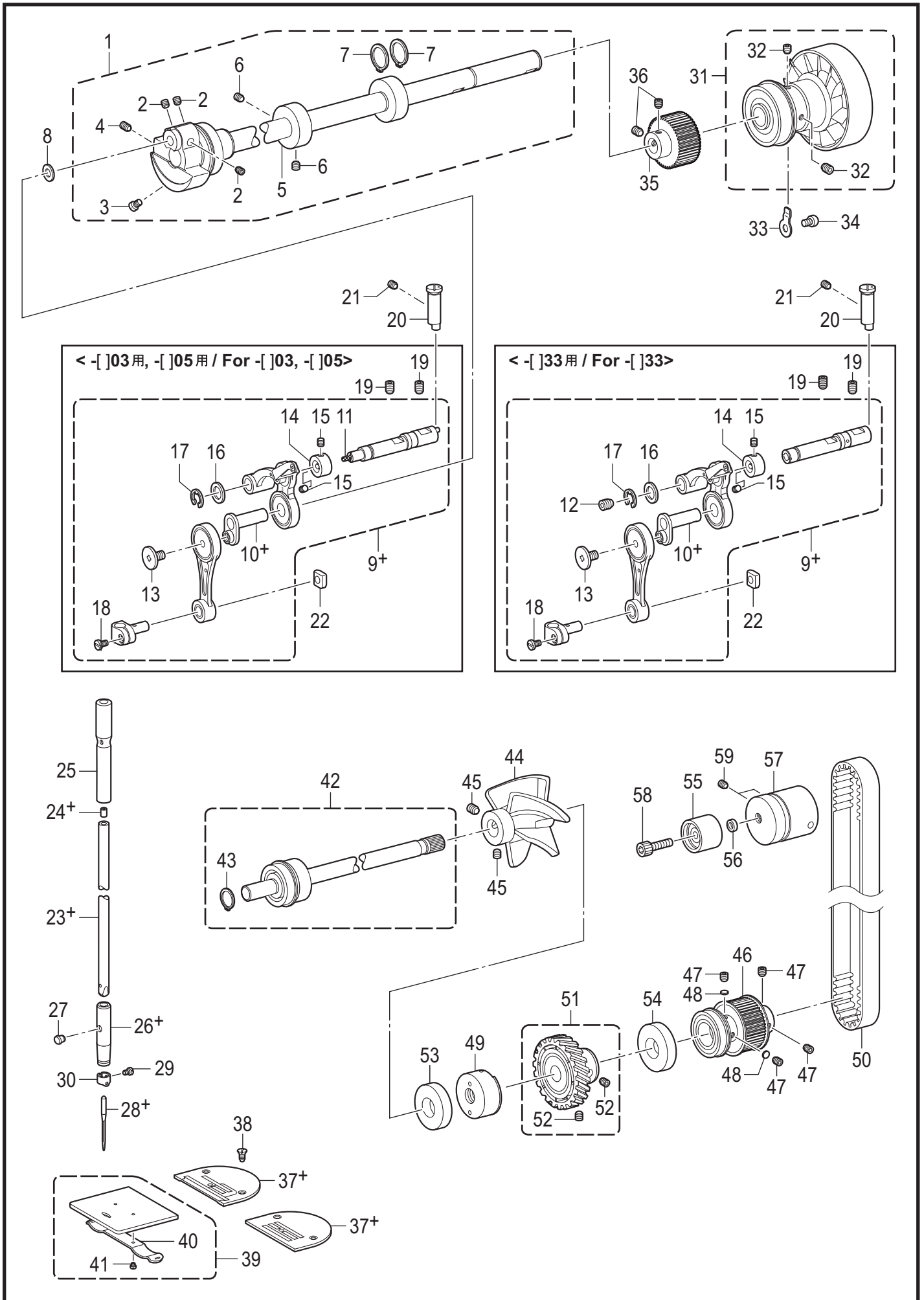

B. 針棒・天秤関係 / Needle bar and thread take-up mechanism

REF.NO	CODE	QTY	品名	NAME OF PARTS	RM
37+	*P.49-51	1	<3枚歯用> ハリイタ	<For 3ROW> NEEDLE PLATE	
37+	*P.49-51	1	<4枚歯用> ハリイタ	<For 4ROW> NEEDLE PLATE	
38	151267001	2	サラネジ4.37	SCREW, FLAT SM4.37-40X8	
39	180018151	1	スベリイタクミ	SLIDE PLATE ASSY	
40	114561001	1	スベリイタウラバネ	SPRING, PLATE	
41	SA9523001	2	シメネジ2.38	SCREW SM2.38	
42	SB5316101	1	シタジククミ	LOWER SHAFT ASSY	
43	048120142	1	トメワジクヨウC12	RETAINING RING EXTERNAL C12	
44	SB4848001	1	シタジクファン	LOWER SHAFT FAN	
45	S23651001	2	アナヒラ6X6ホソメ	SET SCREW SOCKET (FT) M6X6	
46	SB5291101	1	タイミングプーリDオオクミ	TIMING PULLEY D UNIT	
47	S23651001	4	アナヒラ6X6ホソメ	SET SCREW SOCKET (FT) M6X6	
48	SA2378001	2	カンザ4.8	SPACER 4.8	
49	SB5037001	1	シタジクメタル	LOWER SHAFT BUSH	
50	SA2252101	1	タイミングベルト	TIMING BELT	
51	SA1166001	1	シタジクギアクミ	LOWER SHAFT GEAR ASSY	
52	S23651001	2	アナヒラ6X6ホソメ	SET SCREW SOCKET (FT) M6X6	
53	SB5628001	1	オイルシール12-30	OIL SEAL 12-30	
54	SB5629001	1	オイルシール12-35	OIL SEAL 12-35	
55	SB5317001	1	テンションプーリクミ	TENSION PULLEY ASSY	
56	SB4857001	1	テンションプーリカラー	COLLAR	
57	SB4858001	1	ベルトチョウセツジク	REGULATION SHAFT	
58	SB5039001	1	アナボルト8X25	BOLT SOCKET M8X25	
59	012500536	2	アナヒラ5X5	SET SCREW SOCKET (FT) M5X5	

C. 押え関係 / Presser foot mechanism

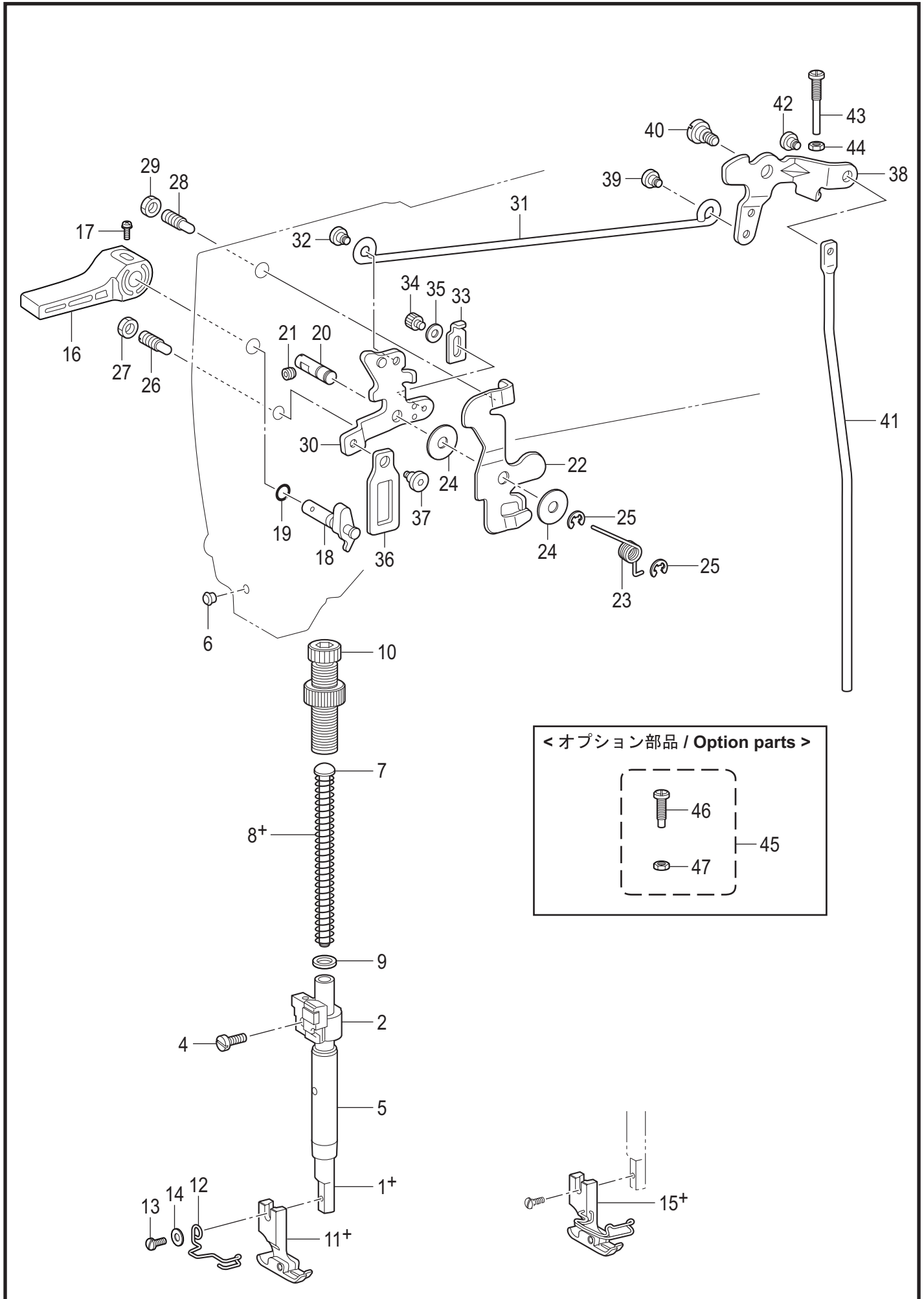

C. 押え関係 / Presser foot mechanism

REF.NO	CODE	QTY	品名	NAME OF PARTS	RM
1+	SA9359001	1	<-□□3用> オサエボウ	<For -□□3> PRESSER BAR	
1+	SA1173101	1	<-□05用> オサエボウ	<For -□05> PRESSER BAR	
2	SB5049001	1	オサエボウダキクミP	P-BAR GUIDE BRACKET ASSY P	
4	SA8903001	1	シメネジ4X12	SCREW M4X12	
5	SA7242001	1	オサエボウメタル	PRESSER BAR BUSH	
6	104833001	1	ゴムセン4.3	RUBBER CAP 4.3	
7	SA7607101	1	オサエバネアンナイ	SPRING GUIDE	
8+	S13561101	1	<-□□3用> オサエバネ	<For -□□3> PRESSER BAR SPRING	
8+	141728001	1	<-□05用> オサエバネ	<For -□05> PRESSER BAR SPRING	
9	140407001	1	ザガネ	WASHER	
10	SB5262001	1	オサエチョウセツネジクミ	PRESSER ADJUSTING SCREW ASSY	
11+	*P.49-50	1	<フィンガーガードねじ止め式> オサエクミ	<For finger guard screwed type> PRESSER FOOT ASSY	
12	SA8100101	1	フィンガーガード	FINGER GUARD	
13	S13385001	1	シメネジ3.57X10	SCREW, SM3.57-40X10	
14	025350132	1	ヒラザガネショウ3.5	WASHER PLAIN S 3.5	
15+	*P.51	1	<フィンガーガード一体式> オサエクミ	<For finger guard integral type> PRESSER FOOT ASSY W/F-GUARD	
16	S31006002	1	オサエアゲテコ	LIFTING LEVER	
17	S39051001	1	ナベザクミ35X12	SCREW, PAN (S/P W) M3.5X12	
18	SB4864001	1	オサエアゲクランク	PRESSER BAR LIFTER CRANK	
19	081004070	1	OリングP4	O RING P4	
20	SB4865001	1	オサエアゲレバージク	PRESSER BAR LIFTER LEVER SHAFT	
21	012500536	1	アナヒラ5X5	SET SCREW SOCKET (FT) M5X5	
22	SB4867101	1	イトユルメイタ	TENSION RELEASE PLATE	
23	SB4873101	1	オサエアゲレバーバネA	SPRING A	
24	SB5229001	2	ザガネ7.3	WASHER 7.3	
25	048050342	2	トメワE5	RETAINING RING E5	
26	SB4870001	1	イトユルメホジョピン	TENSION RELEASE SUPPORT PIN	
27	021060306	1	3シュナット6	NUT 3 M6	
28	SB4870001	1	イトユルメホジョピン	TENSION RELEASE SUPPORT PIN	
29	021060306	1	3シュナット6	NUT 3 M6	
30	SB4866001	1	オサエアゲレバー	PRESSER BAR LIFTER LEVER	
31	SB4872001	1	ヒザアゲレンカン	KNEE LIFTER CONNECTING ROD	
32	SB5030001	1	ダンネジM5	SHOULDER SCREW M5	
33	SB4868001	1	イトユルメキリカエイタ	T-RELEASE REGULATOR PLATE	
34	018400532	1	アナボルト4X5	BOLT SOCKET M4X5	
35	026040236	1	ヒラザガネミガキ4	WASHER PLAIN M 4	
36	SB4869001	1	ヒキアゲイタ	LIFTING PLATE	
37	SA1179001	1	ダンネジ5	SHOULDER SCREW, M5	
38	SB4871001	1	ヒザアゲレバー	KNEE LIFTER LEVER	
39	SB5030001	1	ダンネジM5	SHOULDER SCREW M5	
40	SB0705101	1	オサエアゲリンクダンネジ	LINK SHOULDER SCREW	
41	SB4874101	1	ヒザアゲボウ	KNEE LIFTER BAR	
42	SA1179001	1	ダンネジ5	SHOULDER SCREW, M5	
43	SB5031001	1	チョウセツネジ6	ADJUSTING SCREW 6	
44	021060306	1	3シュナット6	NUT 3 M6	

C. 押え関係 / Presser foot mechanism

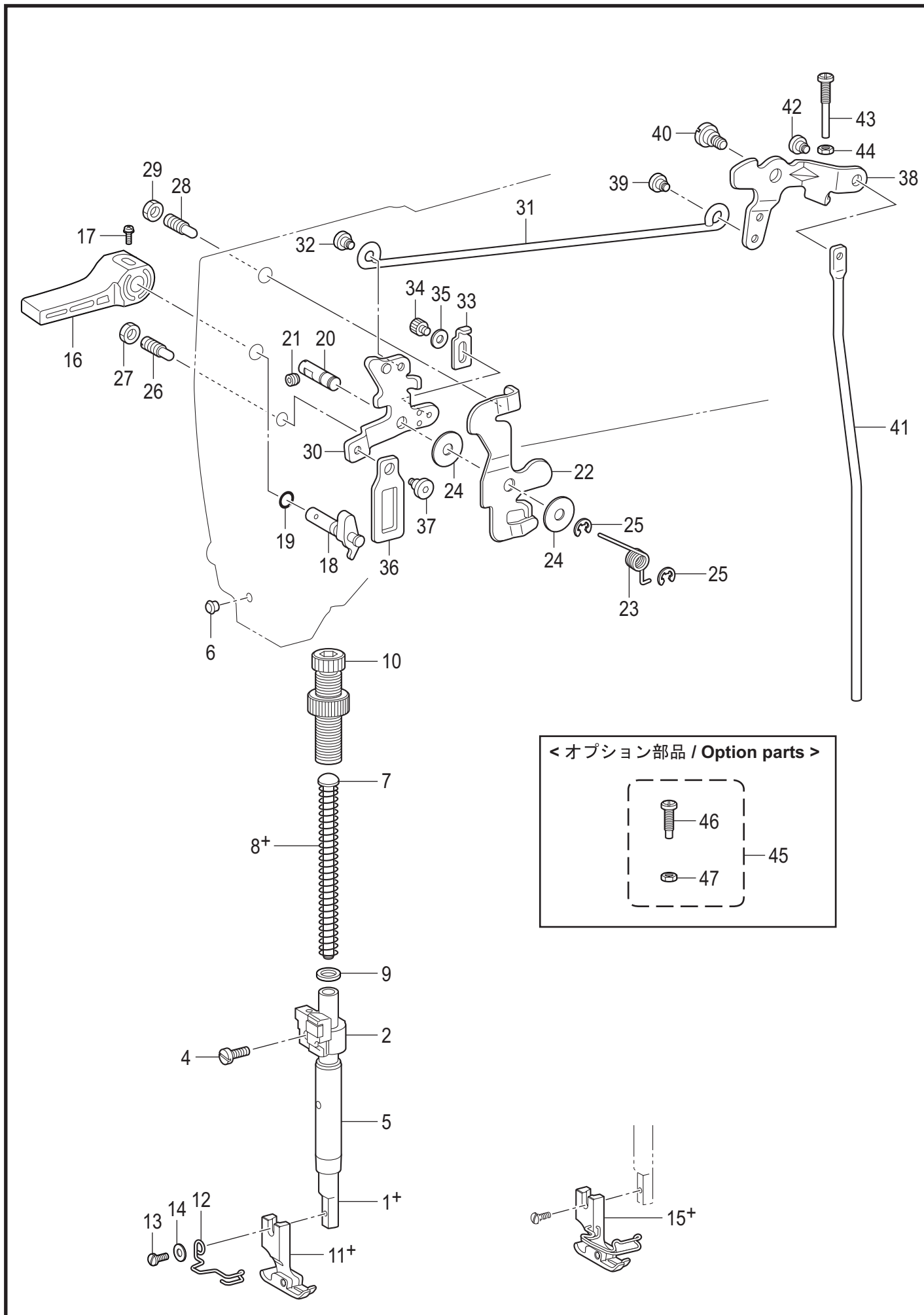

C. 押え関係 / Presser foot mechanism

REF.NO	CODE	QTY	品名	NAME OF PARTS	RM
			<オプション部品>	<OPTION PARTS>	
45	SB6564001	1	チョウセツネジセット	ADJUSTING SCREW SET	
46	SB5674001	1	チョウセツネジ6	ADJUSTING SCREW 6	
47	021060306	1	3シュナット6	NUT 3 M6	

D. 送り関係 / Feed mechanism

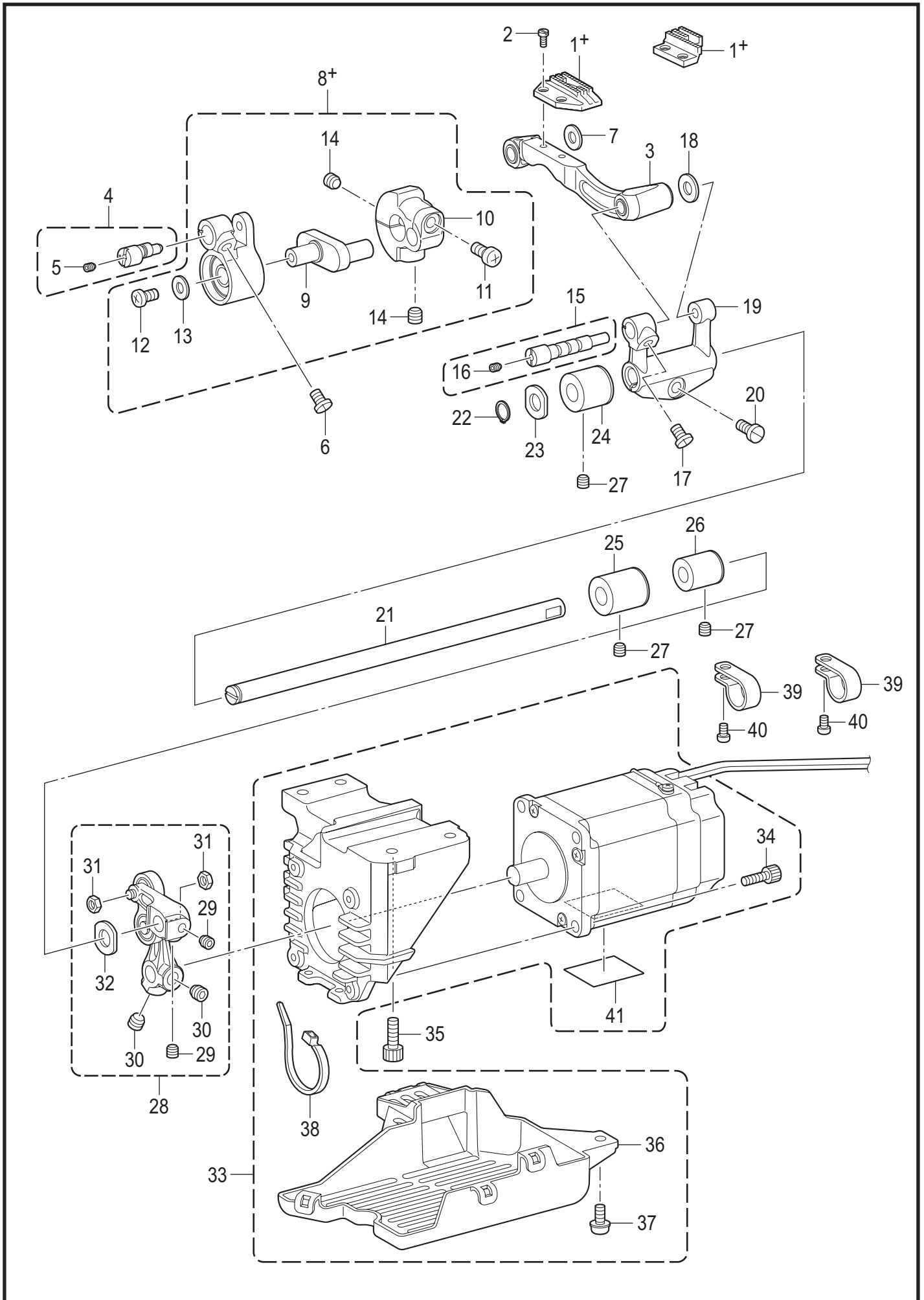

D. 送り関係 / Feed mechanism

REF.NO	CODE	QTY	品名	NAME OF PARTS	RM
1+	*P.49-51	1	<3枚歯用> オクリバ	<For 3ROW> FEED DOG	
1+	*P.49-51	1	<4枚歯用> オクリバ	<For 4ROW> FEED DOG	
2	SB4900001	2	シメネジ3	SCREW M3	
3	SB4879001	1	オクリダイクミ	FEED BAR ASSY	
4	SB5315101	1	ジョウゲオクリダイジククミ	FEED LIFTING R-BAR SHAFT ASSY	
5	014300432	1	アナクボミ3X4	SET SCREW SOCKET (CP) M3X4	
6	SA1242001	1	アタマトメクボミ5X7	SET SCREW 5X7	
7	SB4894001	1	ザガネ4.2 T0.8	WASHER PLAIN 4.2 T0.8	
8+	SB5294201	1	<-□□3用> ジョウゲオクリクミ3	<For -□□3> LIFTING FEED ASSY 3	
8+	SB5297201	1	<-□□05用> ジョウゲオクリクミ5	<For -□□05> LIFTING FEED ASSY 5	
9	SB4885101	1	ジョウゲオクリクランク	LIFTING FEED CRANK	
10	SB4888101	1	ジョウゲオクリウデ	LIFTING FEED ARM	
11	062501016	1	ナベコ5X10	SCREW PAN M5X10	
12	060401016	1	バインド4X10	SCREW BIND M4X10	
13	SB4901001	1	ザガネ4.2 T1.5	WASHER PLAIN 4.2 T1.5	
14	S23651001	2	アナヒラ6X6ホソメ	SET SCREW SOCKET (FT) M6X6	
15	SB5314101	1	オクリダイジククミ	FEED BAR SHAFT ASSY	
16	014300432	1	アナクボミ3X4	SET SCREW SOCKET (CP) M3X4	
17	SA1242001	1	アタマトメクボミ5X7	SET SCREW 5X7	
18	SB4894001	1	ザガネ4.2 T0.8	WASHER PLAIN 4.2 T0.8	
19	SB4887001	1	スイヘイオクリダイウデ	FEED ROCK BRACKET ARM	
20	SA7257001	1	シメネジ5X12	SCREW 5X12	
21	SB4889001	1	スイヘイオクリジク	FEED ROCK SHAFT	
22	048080142	1	トメワジクヨウC8	RETAINING RING EXTERNAL C8	
23	SB4893101	1	ザガネ8	WASHER PLAIN 8	
24	SB4882001	1	オクリジクメタルL	FEED SHAFT BUSH L	
25	SB4883001	1	オクリジクメタルM	FEED SHAFT BUSH M	
26	SB4884001	1	オクリジクメタルR	FEED SHAFT BUSH R	
27	012500536	3	アナヒラ5X5	SET SCREW SOCKET (FT) M5X5	
28	SB5300201	1	スイヘイオクリリンクソウクミ	FEED ROCK LINK UNIT	
29	012500536	2	アナヒラ5X5	SET SCREW SOCKET (FT) M5X5	
30	S23651001	2	アナヒラ6X6ホソメ	SET SCREW SOCKET (FT) M6X6	
31	021350106	2	1シュナット35	NUT 1 M3.5	
32	SB4893101	1	ザガネ8	WASHER PLAIN 8	
33	SB6430001	1	Pモータクミ	P MOTOR ASSY	
34	018401436	4	アナボルト4X14	BOLT SOCKET M4X14	
35	018501436	4	アナボルト5X14	BOLT SOCKET M5X14	
36	SB4892201	1	PMカバー	PM COVER	
37	0A5401006	3	+ナベザクミ4X10DB	SCREW PAN (S/P WASHER) M4X10	
38	228475000	1	ケツソクバンド1.9X80	FASTENING BAND 1.9X80	
39	149287000	2	ナイロンクランプ	CORD HOLDER 7N	
40	0A5401006	2	+ナベザクミ4X10DB	SCREW PAN (S/P WASHER) M4X10	
41	SA4224001	1	マークチュウイ30X40	MARK ATTENTION 30X40	

E. 膝上げ関係 / Knee lifter mechanism

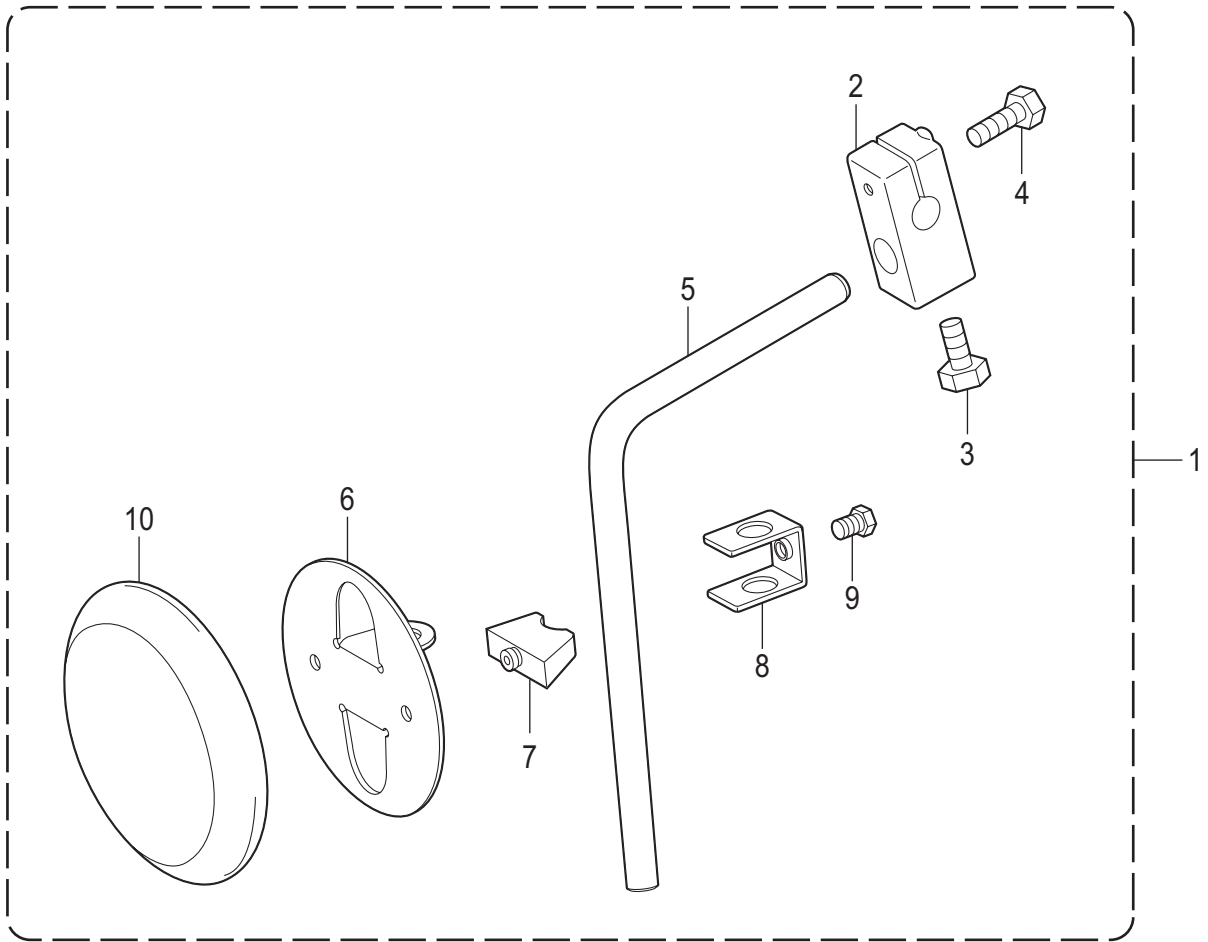

E. 膝上げ関係 / Knee lifter mechanism

REF.NO	CODE	QTY	品名	NAME OF PARTS	RM
1	SB3854001	1	ヒザアテクミ	KNEE LIFTER ASSY	
2	SB1603001	1	ヒザアテツギテ	KNEE LIFTER BRACKET	
3	SB1604001	1	ボルト6X15	BOLT 6X15	
4	SB1605001	1	ボルト6X24	BOLT 6X24	
5	SB3480001	1	ヒザアゲタテジク	KNEE LIFTER BAR	
6	SB1607001	1	ヒザアテ	KNEE LIFTER PLATE	
7	SB1608001	1	ヒザアテササエ	KNEE LIFTER SUPPORT	
8	SB1609001	1	ヒザアテストップ	KNEE LIFTER PLATE STOPPER	
9	SB1610001	1	ボルト6X12	BOLT 6X12	
10	SB1611001	1	ヒザアテカバー	KNEE LIFTER PLATE COVER	

F. かま関係 / Rotary hook mechanism

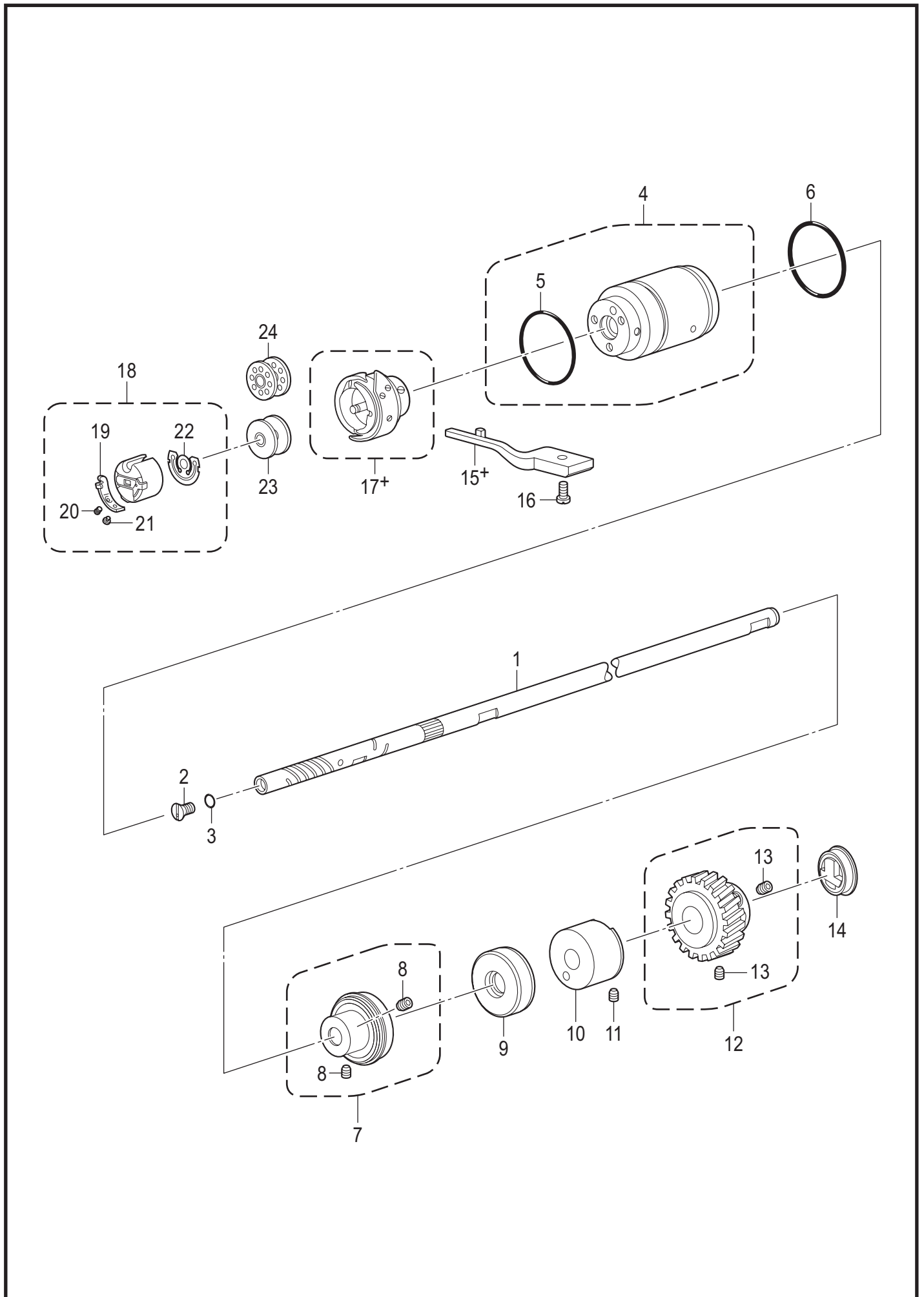

F. かま関係 / Rotary hook mechanism

REF.NO	CODE	QTY	品名	NAME OF PARTS	RM
1	SB4903001	1	カマジク	ROTARY HOOK SHAFT	
2	SB5269001	1	オイルアナフタネジクミ	SCREW CAP W/HOLE ASSY	
3	081004870	1	OリングS4	O RING S4	
4	SB5270001	1	ポンプメタルクミ	PUMP BUSH ASSY	
5	081025870	1	OリングS25	O RING S25	
6	081029870	1	OリングS29	O RING S29	
7	SB5272001	1	ベアリングブッシュクミ	BEARING BUSH ASSY	
8	S23651001	2	アナヒラ6X6ホソメ	SET SCREW SOCKET (FT) M6X6	
9	SA9684001	1	オイルシール	OIL SEAL	
10	SB4904001	1	カマジクギヤメタル	ROTARY HOOK SHAFT GEAR BUSH	
11	012060636	1	アナヒラ6X6	SET SCREW SOCKET (FT) M6X6	
12	SA1286001	1	カマジクギアクミ	ROTARY HOOK SHAFT GEAR ASSY	
13	S23651001	2	アナヒラ6X6ホソメ	SET SCREW SOCKET (FT) M6X6	
14	SB5275101	1	ゴムセン23.5クミ	RUBBER CAP 23.5 ASSY	
			<-□□3用>	<For -□□3>	
15+	SB5041001	1	ウチカマトメ3	HOOK STOPPER 3	
			<-□□05用>	<For -□□05>	
15+	SB5042001	1	ウチカマトメ5	HOOK STOPPER 5	
16	SA8903001	1	シメネジ4X12	SCREW M4X12	
			<-□□3用>	<For -□□3>	
17+	SB6568001	1	SB5274 カマハコクミ	ROTARY HOOK ASSY W/BOX SB5274	
			<-□□05用>	<For -□□05>	
17+	SB1677001	1	SB1678 カマハコクミ	ROTARY HOOK ASSY W/BOX SB1678	
18	S03245001	1	ボビンケースクミ	BOBBIN CASE ASSY	
19	183388001	1	ボビンケースチヨウシバネ	TENSION SPRING	
20	183389001	1	チヨウシバネチヨウセツネジ	ADJUSTING SCREW	
21	183390001	1	チヨウシバネトメネジ	SET SCREW	
22	S03246001	1	クウテンボウシバネ	ANTI-SPIN SPRING	
			<-□□3用>	<For -□□3>	
23	146290001	1	ボビン	BOBBIN	
			<-□□05用>	<For -□□05>	
24	117132001	1	ボビン	BOBBIN	

G. 給油潤滑関係 / Lubrication

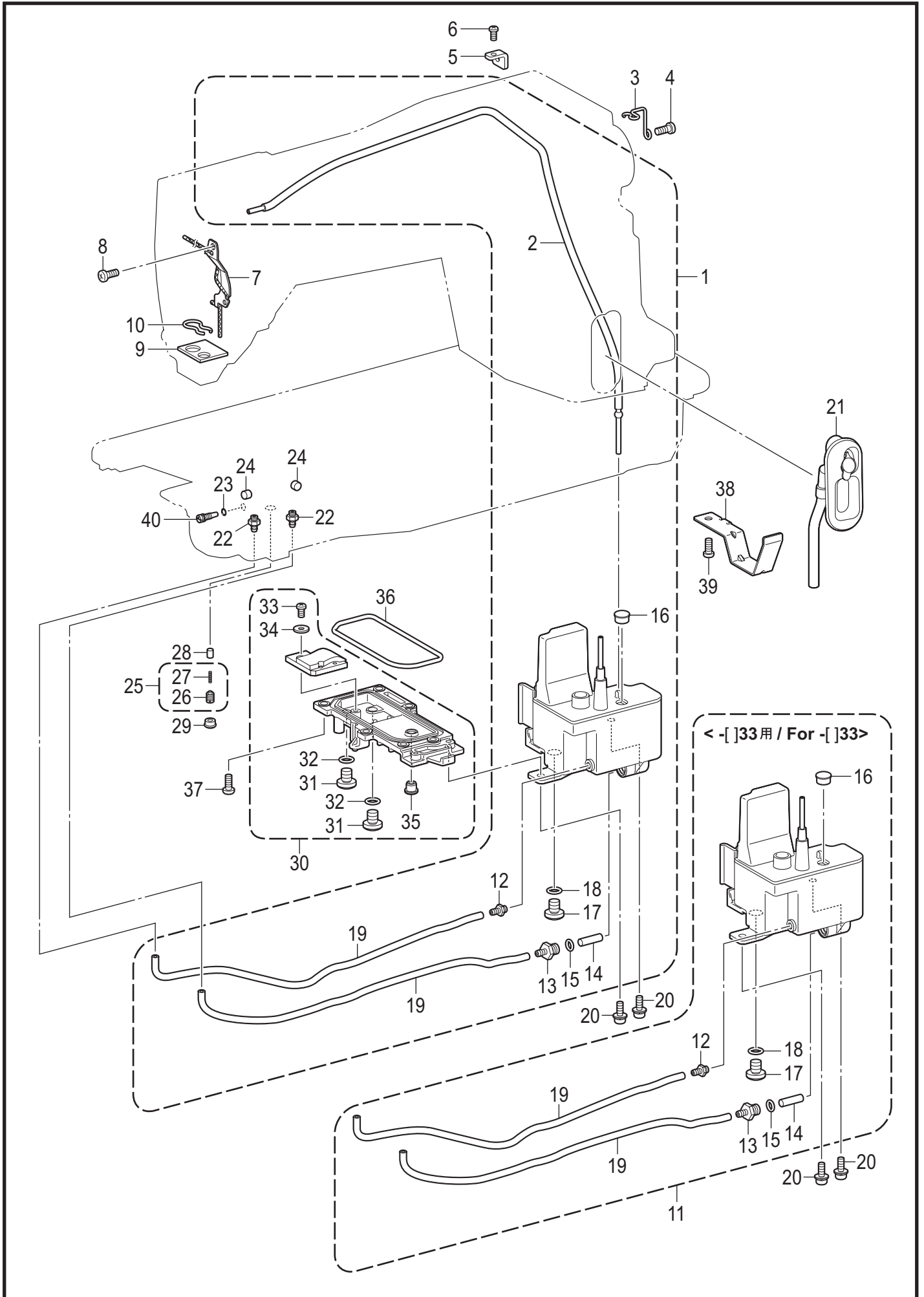

G. 給油潤滑関係 / Lubrication

REF.NO	CODE	QTY	品名	NAME OF PARTS	RM
			<-□0□用>	<For -□0□>	
1	SB5276101	1	オイルタンクソウクミ	OIL TANK UNIT	
2	SB5281001	1	ビニールチューブクミ	OIL TUBE ASSY	
3	SB4911001	1	チューブホルダU	TUBE HOLDER U	
4	062501216	1	ナベコ5X12	SCREW PAN M5X12	
5	SB5002001	1	チューブフックU	TUBE HOOK U	
6	062400816	1	ナベコ4X8	SCREW PAN M4X8	
7	SB5287001	1	トウシンホルダークミ	WICK HOLDER ASSY	
8	062500816	1	ナベコ5X8	SCREW PAN M5X8	
9	SB5036001	1	ハリボウフェルト	NEEDLE BAR FELT	
10	145737021	1	フェルトオサエ	FELT SUPPORT	
			<-□33用>	<For -□33>	
11	SB5639101	1	オイルタンクソウクミD	OIL TANK UNIT D	
12	S25382001	1	オイルクチ	OIL FEEDING PIPE	
13	SA8989001	1	オイルクチ	OIL FEEDING PIPE	
14	SA8987001	1	フィルタ	FILTER	
15	081006670	1	OリングPW6	O RING PW6	
16	104821001	1	ゴムセン10.5	RUBBER CAP 10.5	
17	SA1303101	1	シメネジ8	SCREW M8	
18	081008070	1	OリングP8	O RING P8	
19	SB5280001	2	ビニールチューブ(350)	VINYL TUBE (350)	
20	0A4501206	2	+ナベザクミ5X12DA	SCREW PAN (S/P WASHER) M5X12	
21	SB5284201	1	キュウユクチクミ	OIL FEEDING POCKET ASSY	
22	S25382001	2	オイルクチ	OIL FEEDING PIPE	
23	081004870	1	OリングS4	O RING S4	
24	140327001	2	ゴムセン6.3	RUBBER CAP 6.3	
25	SA7636201	1	ポンプフタネジクミ	PUMP CAP SCREW ASSY	
26	S25380601	1	ポンプフタネジ	CAP SCREW PUMP	
27	S52764001	1	プランジヤ-バネ	SPRING COMPRESSION	
28	144875001	1	プランジヤ-	PLUNGER	
29	SB4915001	1	ゴムセン	RUBBER CAP	
30	SB5286201	1	ベッドソコフタクミ	BED BOTTOM COVER ASSY	
31	SA1303101	2	シメネジ8	SCREW M8	
32	081008070	2	OリングP8	O RING P8	
33	062400816	1	ナベコ4X8	SCREW PAN M4X8	
34	025040332	1	ヒラザガネダイ4	WASHER PLAIN L 4	
35	SB5675001	1	ゴムセン8	RUBBER CAP 8	
36	SB4918001	1	ソコフタパッキン	BOTTOM COVER PACKING	
37	062501216	6	ナベコ5X12	SCREW PAN M5X12	
38	SB5004001	1	オイルタンクガード	OIL TANK GUARD	
39	062501216	1	ナベコ5X12	SCREW PAN M5X12	
40	SB4916001	1	オイルチョウセツネジ	ADJUSTING SCREW	

H. 糸通し関係 / Threading mechanism

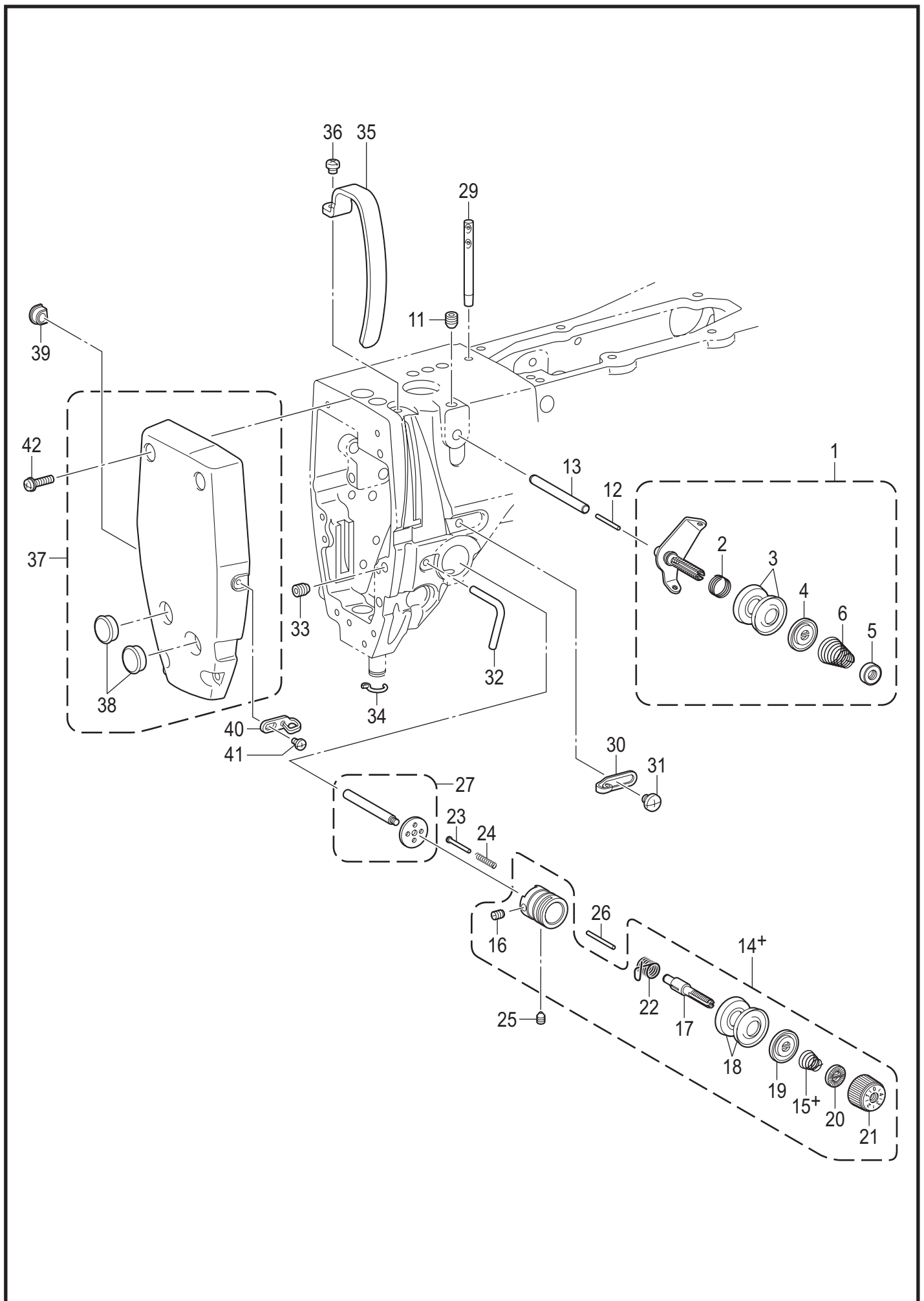

H. 糸通し関係 / Threading mechanism

REF.NO	CODE	QTY	品名	NAME OF PARTS	RM
1	SB5265101	1	プレテンションクミP	PRE-TENSION ASSY P	
2	SB4933001	1	イトアンナイバネA	THREAD GUIDE SPRING	
3	145446001	2	イトチヨウシサラ	DISC TENSION	
4	159805001	1	イトチヨウシサラオサエ	TENSION DISC PRESSER	
5	100136001	1	イトチヨウシナツト	TENSION NUT	
6	SA4146101	1	フクチヨウシバネ	SUB TENSION SPRING	
11	012500536	1	アナヒラ5X5	SET SCREW SOCKET (FT) M5X5	
12	SB4928001	1	イトユルメピンA	TENSION RELEASE PIN A	
13	SB4929001	1	イトユルメボウA	TENSION RELEASE STUD A	
			<-□□3用>	<For -□□3>	
14+	SB5288101	1	イトチヨウシダイクミ3	THREAD TENSION BRACKET ASSY	
15+	SA7275001	1	イトチヨウシバネ	TENSION SPRING	
			<-□□05用>	<For -□□05>	
14+	SB5289101	1	イトチヨウシダイクミ5	THREAD TENSION BRACKET ASSY	
15+	S04632101	1	イトチヨウシバネ	TENSION SPRING	
16	100402004	1	トメネジ3.57	SET SCREW SM3.57	
17	116922201	1	イトチヨウシボウ	TENSION STUD	
18	145446001	2	イトチヨウシサラ	DISC TENSION	
19	159805001	1	イトチヨウシサラオサエ	TENSION DISC PRESSER	
20	S12441001	1	チヨウシバネウエザガネ	WASHER	
21	S31032002	1	イトチヨウシナツト	TENSION NUT	
22	S02620401	1	イトトリバネ	THREAD TAKE-UP SPRING	
23	SB4922101	1	イトトリバネストッパ	THREAD TAKE-UP SPRING STOPPER	
24	SB4923001	1	ストッパヨウバネ	STOPPER SPRING	
25	SA1229101	1	アナトメネジ6トガリ	SET SCREW (FT) M6X6	
26	SB4924001	1	イトユルメピン	TENSION RELEASE PIN	
27	SB5627001	1	イトユルメボウクミ	TENSION RELEASE STUD ASSY	
29	SB3595101	1	イトタテボウ	SPOOL PIN	
30	SA1345001	1	ア-ムイトアンナイR	ARM THREAD GUIDE, R	
31	060500616	1	バインド5X6	SCREW BIND M5X6	
32	SB4934001	1	ア-ムイトカケ	ARM THREAD GUIDE	
33	012500536	1	アナヒラ5X5	SET SCREW SOCKET (FT) M5X5	
34	SA7272201	1	ハリボウメタルDイトアンナイ	THREAD GUIDE D	
35	SA9854001	1	テンビンカバー	THREAD TAKE-UP LEVER COVER	
36	062500816	1	ナベコ5X8	SCREW PAN M5X8	
37	SB5630101	1	メンイタクミ	FACE PLATE ASSY	
38	SA7849001	2	ゴムセン	RUBBER CAP	
39	SB4932001	1	メンイタゴムセンP	FACE PLATE RUBBER CAP P	

H. 糸通し関係 / Threading mechanism

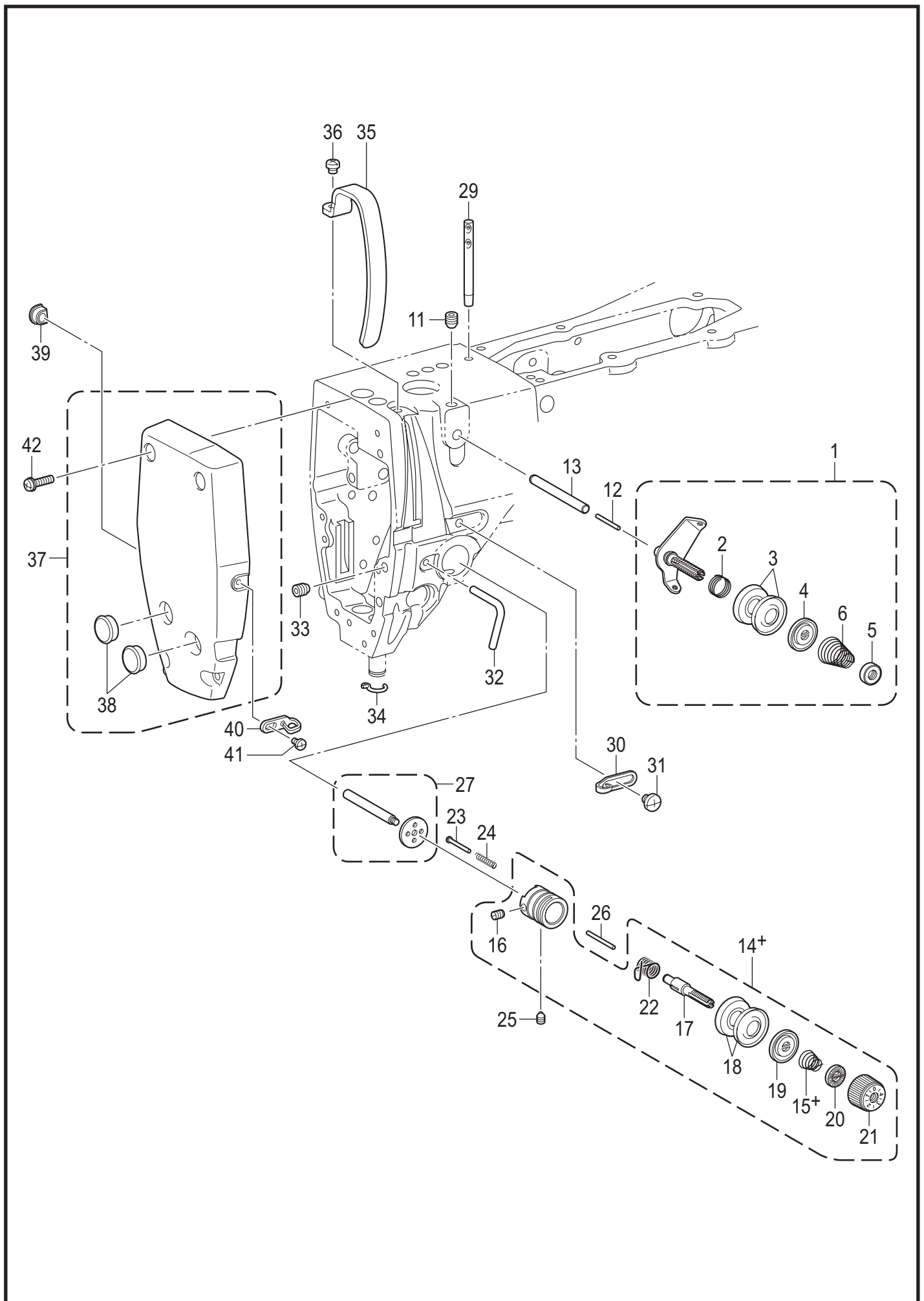

H. 糸通し関係 / Threading mechanism

REF.NO	CODE	QTY	品名	NAME OF PARTS	RM
40	SA7271001	1	メンイタイトアンナイ	FACE PLATE THREAD GUIDE	
41	060300606	1	バインド3X6	SCREW BIND M3X6	
42	0A4401606	4	+ナベザクミ4X16DA	SCREW PAN (S/P WASHER) M4X16	

J. 糸巻関係 / Bobbin winder mechanism

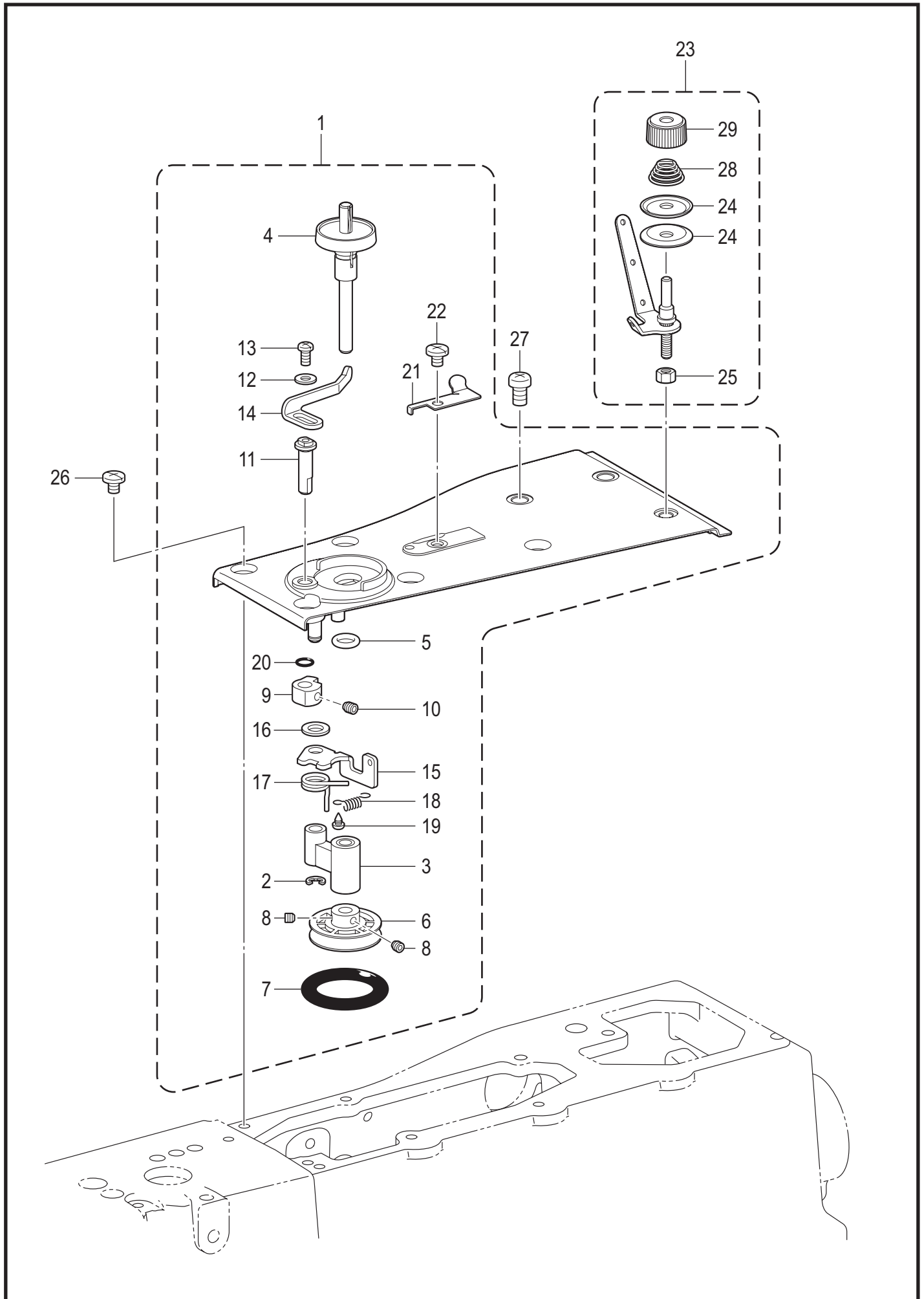

J. 糸巻関係 / Bobbin winder mechanism

REF.NO	CODE	QTY	品名	NAME OF PARTS	RM
1	SB5652101	1	ウワフタオオクミ	TOP COVER UNIT ASSY	
2	048050342	1	トメワE5	RETAINING RING E5	
3	SB5009001	1	イトマキジクウケクミ	B-WINDER SUPPORT ASSY	
4	SB5010001	1	イトマキジククミ	BOBBIN WINDER SHAFT ASSY	
5	SB3540001	1	ストッパゴム	STOPPER RUBBER	
6	SB4936001	1	イトマキクルマ	BOBBIN WINDER WHEEL	
7	SB4940001	1	ゴムリング	RUBBER RING	
8	012400432	2	アナヒラ4X4	SET SCREW SOCKET (FT) M4X4	
9	SB3544001	1	ボビンオサエカム	BOBBIN PRESSER CAM	
10	012500536	1	アナヒラ5X5	SET SCREW SOCKET (FT) M5X5	
11	SB3545101	1	イトマキウデジク	BOBBIN WINDER ARM SHAFT	
12	SB3548001	1	ザガネ	WASHER	
13	062400816	1	ナベコ4X8	SCREW PAN M4X8	
14	SB5014001	1	ボビンオサエ	BOBBIN PRESSER	
15	SB3551001	1	イトマキレバー	BOBBIN WINDER LEVER	
16	025060232	1	ヒラザガネチュウ6	WASHER PLAIN M 6	
17	SB3552001	1	モドシバネ	SPRING	
18	SB3553001	1	イトマキレバーバネ	BOBBIN WINDER LEVER SPRING	
19	037300616	1	Vナベタッピン3X6	TAPPING SCREW PAN V M3X6	
20	081004070	1	OリングP4	O RING P4	
21	SA1360101	1	メス	KNIFE	
22	060501016	1	バインド5X10	SCREW BIND M5X10	
23	SB5008001	1	イトマキチョウシクミ	BOBBIN WINDER TENSION ASSY	
24	145446002	2	イトチョウシサラ	DISC TENSION	
25	SB5013001	1	ナット4.37	NUT 3 SM4.37	
26	060501016	5	バインド5X10	SCREW BIND M5X10	
27	062061616	1	ナベコ6X16	SCREW PAN M6X16	
28	SB5011001	1	イトチョウシバネ	TENSION SPRING	
29	SB5012001	1	イトチョウシナット	THREAD TENSION NUT	

K. 糸切り関係 / Thread trimmer mechanism

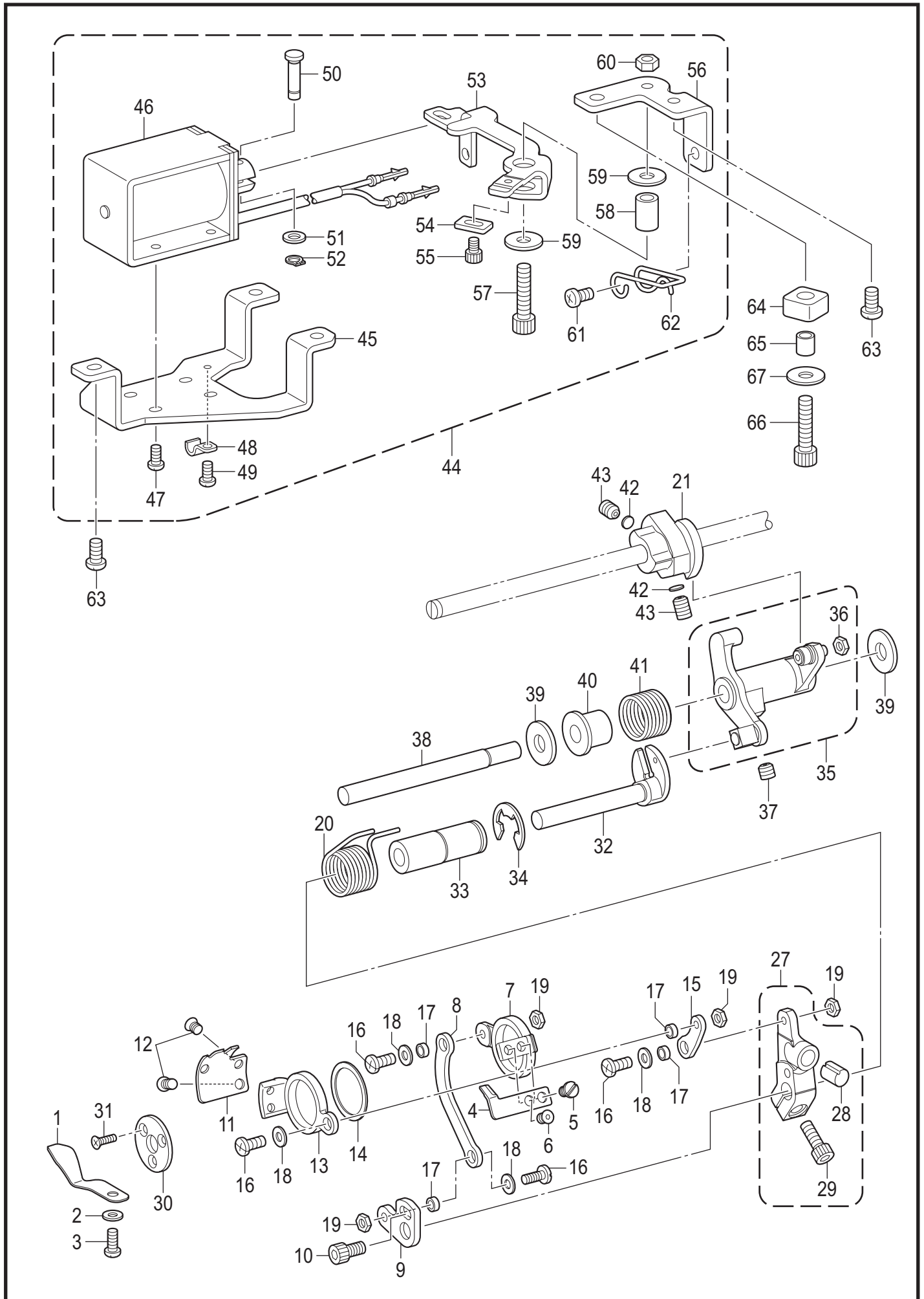

S-7300A-403

K. 糸切り関係 / Thread trimmer mechanism

REF.NO	CODE	QTY	品名	NAME OF PARTS	RM
1	SB4954101	1	イトサバキ	LOWER THREAD FINGER	
2	026040236	1	ヒラザガネミガキ4	WASHER PLAIN M 4	
3	062400616	1	ナベコ4X6	SCREW PAN M4X6	
4	SB4941001	1	ウワメス	UPPER KNIFE	
5	SB4943001	1	シメネジ4.37	FLAT SCREW 4.37	
6	148537101	1	サラネジ4.37	SCREW, FLAT (W/SOCKET) SM4.37	
7	SB4950201	1	ウワメスホルダ	UPPER KNIFE HOLDER	
8	SB4949101	1	ウワメスレンカン	UPPER KNIFE CONNECTING ROD	
9	SB4948101	1	ウワメスレバー	UPPER KNIFE LEVER	
10	018501036	1	アナボルト5X10	BOLT SOCKET M5X10	
11	SB4942101	1	シタメス	LOWER KNIFE	
12	148537101	2	サラネジ4.37	SCREW, FLAT (W/SOCKET) SM4.37	
13	SB4952101	1	シタメスホルダ	LOWER KNIFE HOLDER	
14	SB4969001	1	スペーサ	SPACER	
15	SB4951201	1	シタメスレンカン	LOWER KNIFE CONNECTING ROD	
16	060401016	4	バインド4X10	SCREW BIND M4X10	
17	SA5329001	4	カラー	COLLAR	
18	100645003	4	ザガネ	WASHER	
19	021400306	4	3シュナット4	NUT 3 M4	
20	SB4957001	1	フタマタジクモドシバネP	THREAD TRIMMER LEVER SPRING P	
21	SB4944001	1	イトキリカムB	THREAD TRIMMER CAM B	
27	SB5631101	1	イトキリレバークミ	THREAD TRIMMER LEVER ASSY	
28	SA7285101	1	レバーストツパ	LEVER STOPPER	
29	018501436	1	アナボルト5X14	BOLT SOCKET M5X14	
30	SA7287001	1	イトキリホルダオサエイタ	KNIFE HOLDER PRESSER PLATE	
31	004301016	3	+サラコ3X10	SCREW FLAT M3X10	
32	SB4955001	1	フタマタジク	FORKED SHAFT	
33	SB4956101	1	フタマタジクメタル	FORKED SHAFT BUSH	
34	SB4968001	1	トメワE12	RETAINING RING_E12	
35	SB5301001	1	イトキリカムレバーソウクミ	THREAD TRIMMER LEVER UNIT	
36	105234003	1	ナット4.37	NUT SM4.37	
37	S23651001	1	アナヒラ6X6ホソメ	SET SCREW SOCKET (FT) M6X6	
38	SB4960001	1	カムレバージク	THREAD TRIMMER CAM LEVER SHAFT	
39	S25434000	2	クツシヨンゴム	RUBBER CUSHION	
40	SB4962001	1	カラー	COLLAR	
41	SB4961001	1	カムレバーモドシバネ	SPRING EXTENSION	
42	154567000	2	カンザ5.3	SPACER 5.3	
43	014771032	2	アナクボミ635-40X10	SET SCREW SOCKET SM6.35-40X10	
44	SB5310101	1	イトキリソレノイドクミ	THREAD TRIMMER SOLENOID ASSY	
45	SB4964001	1	イトキリソレノイドダイ	THREAD TRIMMER SOLENOID BASE	
46	SB5257001	1	イトキリソレノイド	THREAD TRIMMER SOLENOID	
47	062400816	4	ナベコ4X8	SCREW PAN M4X8	
48	140647121	1	コードオサエ	CORD HOLDER	
49	062400816	1	ナベコ4X8	SCREW PAN M4X8	
50	SA9716001	1	レンケツピン	PIN	

K. 糸切り関係 / Thread trimmer mechanism

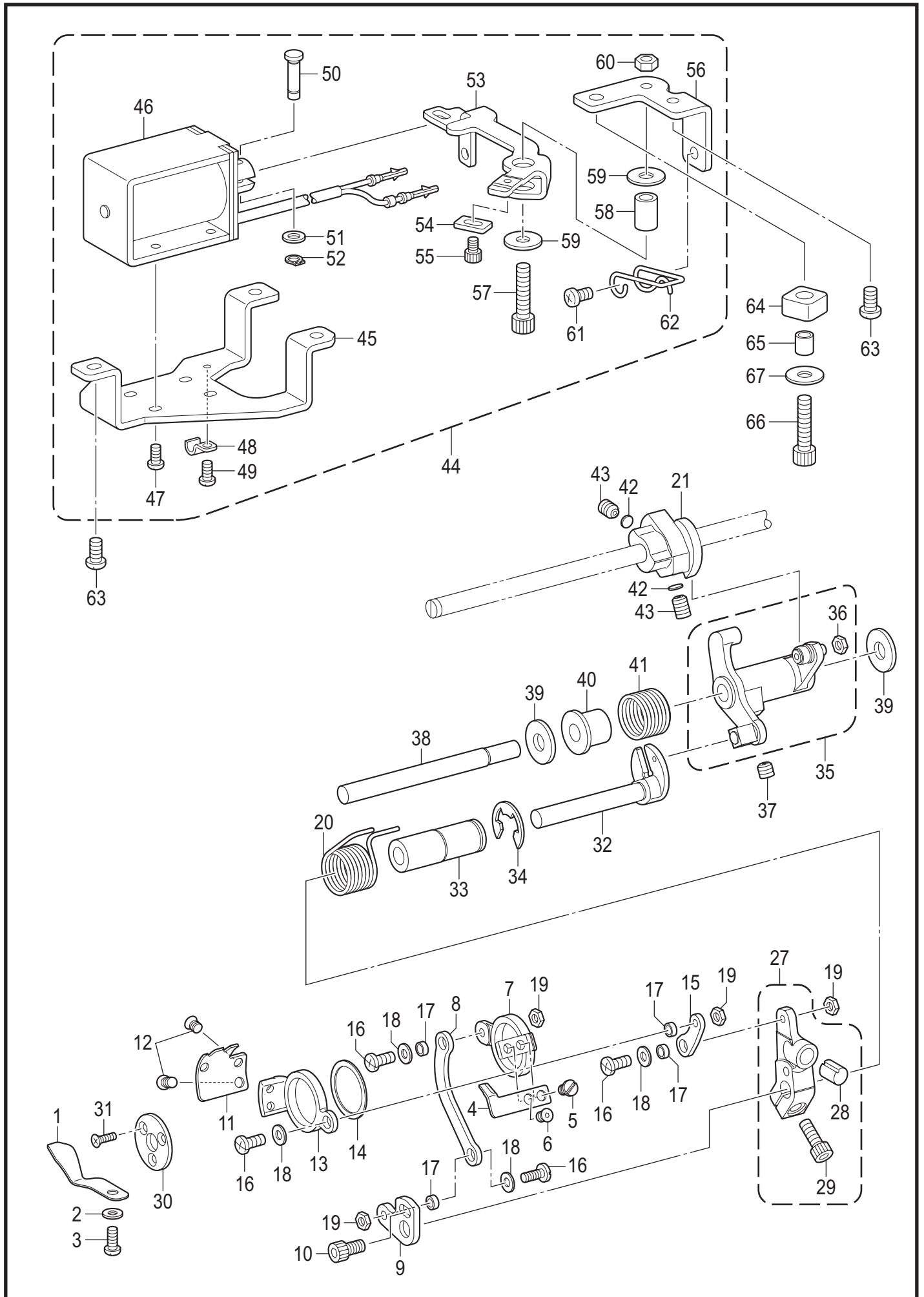

K. 糸切り関係 / Thread trimmer mechanism

REF.NO	CODE	QTY	品名	NAME OF PARTS	RM
51	026050136	1	ヒラザガネコガタ5	WASHER PLAIN S 5	
52	048050142	1	トメワジクヨウC5	RETAINING RING EXTERNAL C5	
53	SB4963001	1	ソレノイドレバー	SOLENOID LEVER	
54	SB4965001	1	ソレノイドストッパイタ	SOLENOID STOPPER PLATE	
55	018400636	1	アナボルト4X6	BOLT SOCKET M4X6	
56	SB4967101	1	ソレノイドレバーダイ	SOLENOID LEVER BASE	
57	018062536	1	アナボルト6X25	BOLT SOCKET M6X25	
58	SB5650001	1	カラー	COLLAR	
59	SA9827001	2	ザガネ	WASHER PLAIN	
60	021060306	1	3シュナット6	NUT 3 M6	
61	062501216	1	ナベコ5X12	SCREW PAN M5X12	
62	SB5673001	1	チューブホルダワイヤD	TUBE HOLDER WIRE D	
63	062501016	4	ナベコ5X10	SCREW PAN M5X10	
64	SB4966001	1	ソレノイドストッパゴム	SOLENOID STOPPER RUBBER	
65	SB4953001	1	カラー	COLLAR	
66	018062036	1	アナボルト6X20	BOLT SOCKET M6X20	
67	025060332	1	ヒラザガネダイ6	WASHER PLAIN L 6	

L. 糸緩め関係 / Tension release mechanism

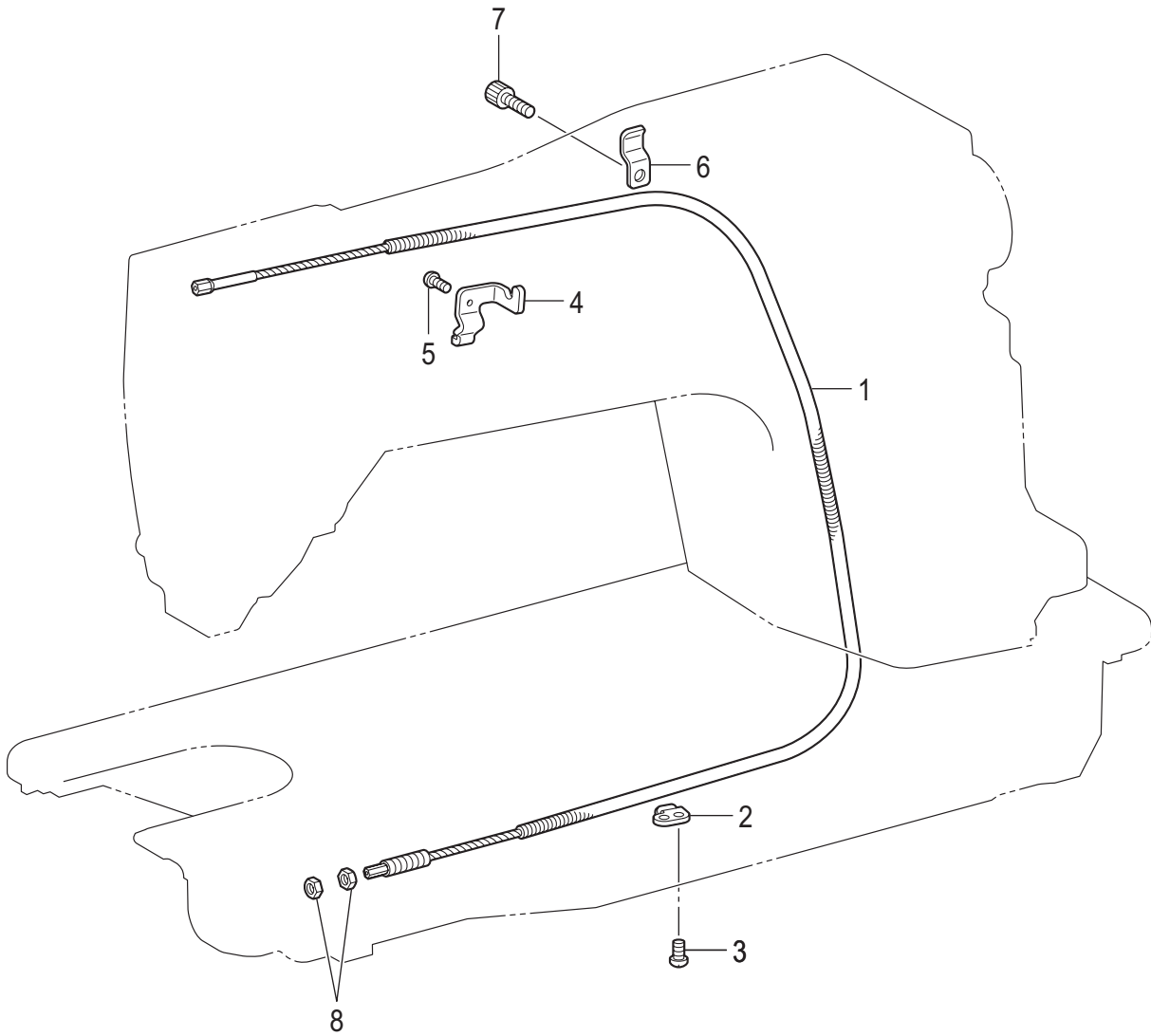

L. 糸緩め関係 / Tension release mechanism

REF.NO	CODE	QTY	品名	NAME OF PARTS	RM
1	SB4970001	1	イトユルメワイヤー	TENSION RELEASE WIRE	
2	SB4971001	1	ワイヤホルダD	WIRE HOLDER D	
3	062400816	1	ナベコ4X8	SCREW PAN M4X8	
4	SB4972001	1	ワイヤホルダU	WIRE HOLDER U	
5	062401216	1	ナベコ4X12	SCREW PAN M4X12	
6	SA1388101	1	コードオサエ	CORD HOLDER	
7	018500836	1	アナボルト5X8	BOLT SOCKET M5X8	
8	110161004	2	ナツト4.76	NUT SM4.76	

M. 糸払い関係 (-4□□) / Thread wiper mechanism (For -4□□)

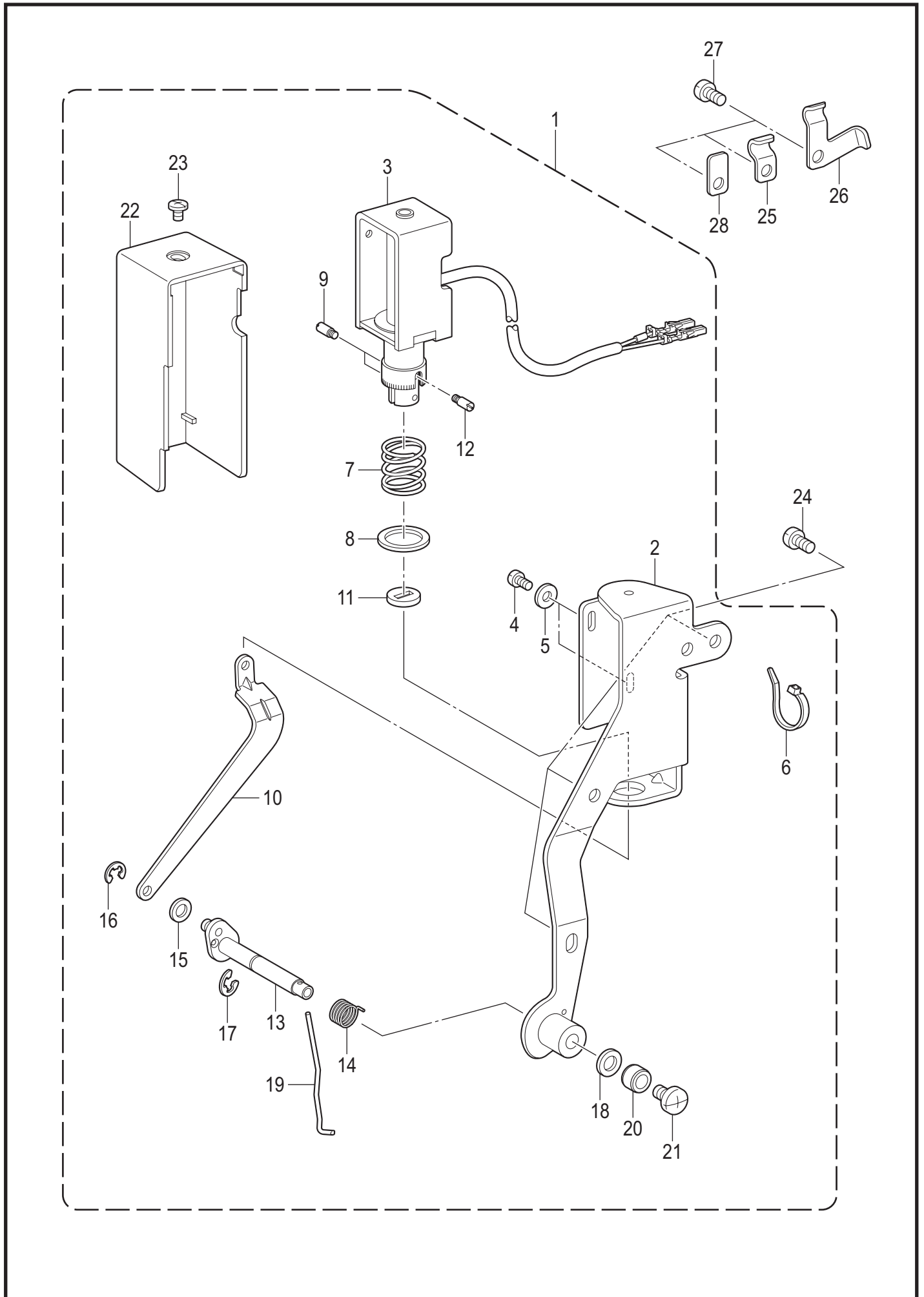

M. 糸払い関係 (-4□□用) / Thread wiper mechanism (For -4□□)

REF.NO	CODE	QTY	品名	NAME OF PARTS	RM
1	SB4846101	1	イトハライソウチクミ	THREAD WIPER DEVICE ASSY	
2	SB5237101	1	イトハライドダイ	THREAD WIPER BASE	
3	SB5258001	1	イトハライソレノイド	THREAD WIPER SOLENOID	
4	062300616	2	ナベコ3X6	SCREW PAN M3X6	
5	026030136	2	ヒラザガネコガタ3	WASHER PLAIN S 3	
6	SB4155001	1	バンド	BAND	
7	SA9771001	1	イトハライバネ	THREAD WIPER SPRING	
8	S41205001	1	ヒラザガネ	WASHER, PLAIN	
9	S25456001	2	プランジャピン	PLUNGER PIN	
10	SB5238001	1	イトハライロッド	THREAD WIPER ROD	
11	S41207000	1	スペーサゴム	SPACER RUBBER	
12	S25456001	1	プランジャピン	PLUNGER PIN	
13	SB5239001	1	イトハライクランククミ	THREAD WIPER CRANK ASSY	
14	SA9352001	1	ワイパーバネ	WIPER SPRING	
15	110735022	1	ザガネ	WASHER	
16	048030342	1	トメワE3	RETAINING RING E3	
17	048040342	1	トメワE4	RETAINING RING E4	
18	SA8085001	1	ザガネ	WASHER	
19	SA9779001	1	イトハライ	THREAD WIPER	
20	146288021	1	イトハライジクカラ-	THREAD WIPER STUD COLLAR	
21	060400516	1	バインド4X5	SCREW BIND M4X5	
22	SB5242001	1	ソレノイドカバー	SOLENOID COVER	
23	060400516	1	バインド4X5	SCREW BIND M4X5	
24	062500816	3	ナベコ5X8	SCREW PAN M5X8	
25	SA2689101	1	コードオサエ	CORD HOLDER	
26	SB5306001	1	コードオサエU	CORD HOLDER U	
27	062500816	3	ナベコ5X8	SCREW PAN M5X8	
28	SB5028001	1	コードオサエ	CORD HOLDER	

N1. コントロールボックス関係 / Control box

< 欧州向用 / For Europe >

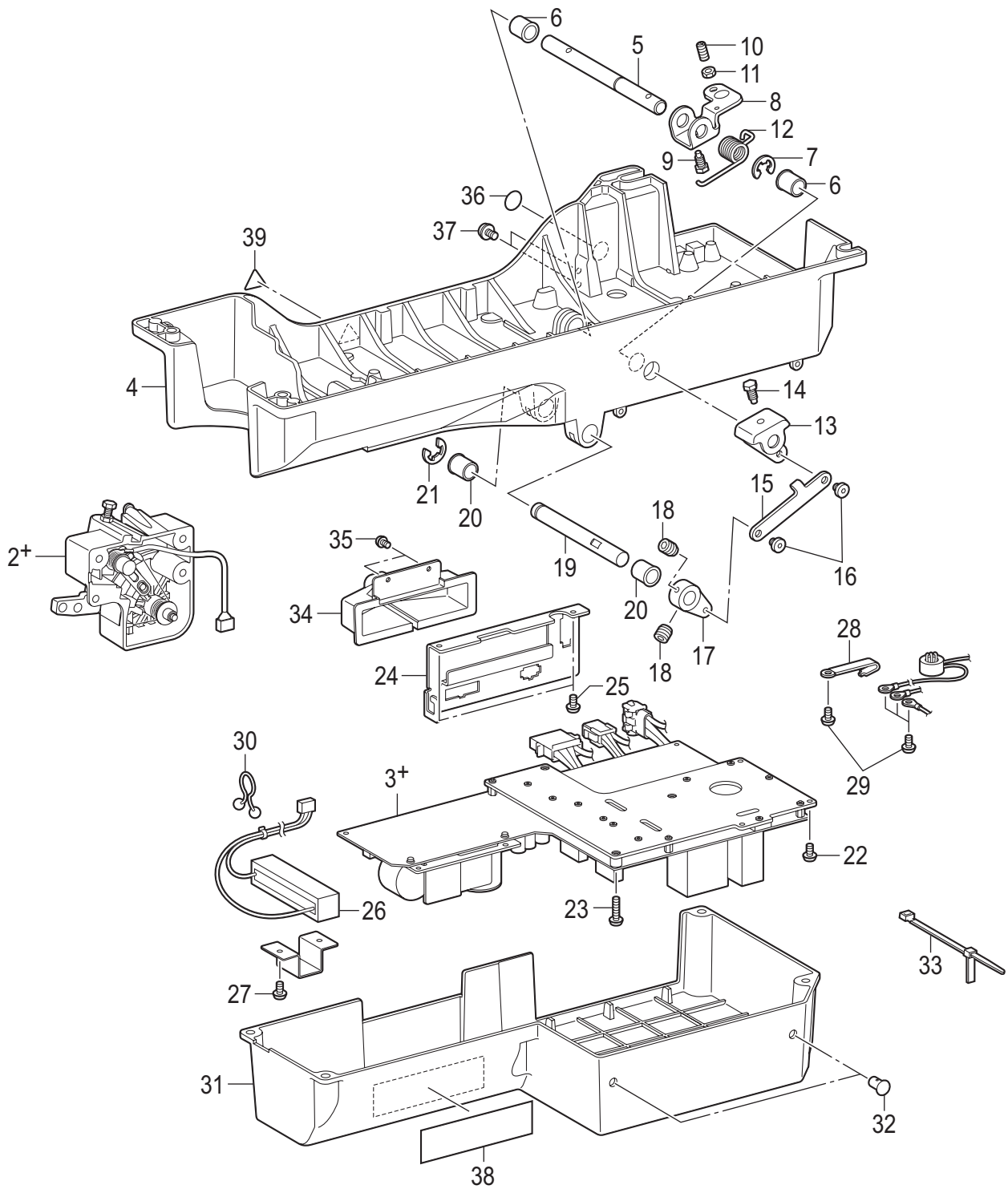
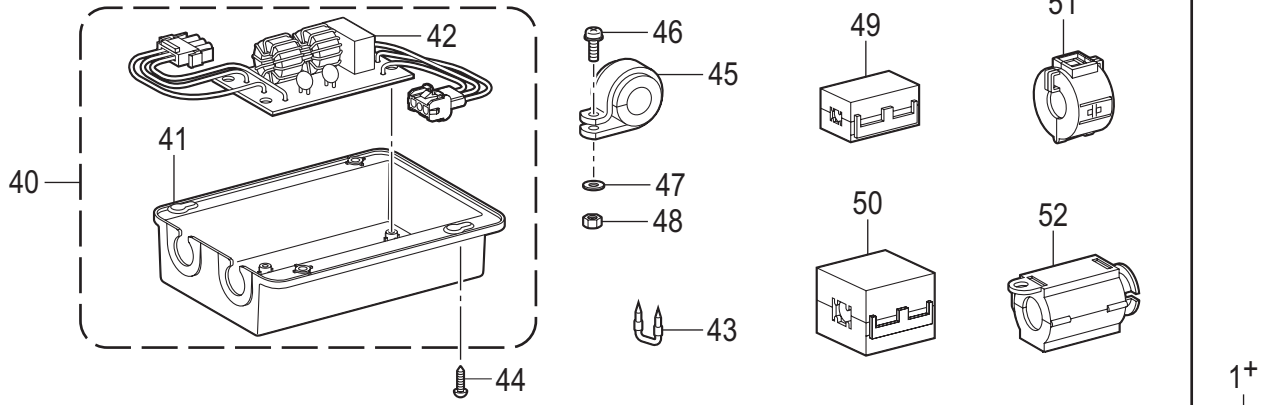

N1. コントロールボックス関係 / Control box

REF.NO	CODE	QTY	品名	NAME OF PARTS	RM
			<日本、輸出一般向用>	<For Japan and General export>	
1+	SB6454001	1	BOXクミ J/A ホキユウ	7300A BOX ASSY J/A SUPPLY	
2+	SB3817401	1	フミコユニット-EX	TREADLE UNIT-EX	
3+	SB6457001	1	メインキバンクミホキユウ	MAIN PCB ASSY SUPPLY	
			<中国向用>	<For China>	
1+	SB6453001	1	BOXクミ CN ホキユウ	7300A BOX ASSY CN SUPPLY	
2+	SB3816101	1	フミコユニット-CN	TREADLE UNIT-CN	
3+	SB6457001	1	メインキバンクミホキユウ	MAIN PCB ASSY SUPPLY	
			<米州向用>	<For the Americas>	
1+	SB6455001	1	BOXクミ US ホキユウ	7300A BOX ASSY US SUPPLY	
2+	SB4587301	1	フミコユニット-US	TREADLE UNIT-US	
3+	SB6457001	1	メインキバンクミホキユウ	MAIN PCB ASSY SUPPLY	
			<欧州向用>	<For Europe>	
1+	SB6456001	1	BOXクミ CE ホキユウ	7300A BOX ASSY CE SUPPLY	
2+	SB4587301	1	フミコユニット-US	TREADLE UNIT-US	
3+	SB6458001	1	メインキバンクミ CE ホキユウ	MAIN PCB ASSY CE SUPPLY	
4	SB4973101	1	ボトムカバー	BOTTOM COVER	
5	SB4976001	1	ヒザアゲヨコジクR	KNEE LIFTER SHAFT R	
6	149578020	2	ヨコジクブツシュ	BUSH	
7	146293001	1	トメワE10	RETAINING RING E10	
8	SB4978001	1	ヒザアゲR	KNEE LIFTER R	
9	SB5034001	1	ボルト5.95X13	BOLT SM5.95X13	
10	SB3587001	1	トメネジ5.95	SET SCREW SM5.95	
11	100022004	1	ナツト5.95	NUT SM5.95	
12	SB4979001	1	ヒザアゲバネ	TWIST SPRING	
13	SB4980001	1	ヒザアゲF	KNEE LIFTER F	
14	SB3586001	1	ボルト5.95	BOLT SM5.95	
15	SB4981101	1	ヒザアゲレンケツカン	KNEE LIFTER CONNECTING ROD	
16	SA1179001	2	ダンネジ5	SHOULDER SCREW M5	
17	SB4982101	1	ヒザアゲレバーD	KNEE LIFTER LEVER D	
18	012060636	2	アナヒラ6X6	SET SCREW SOCKET (FT) M6X6	
19	SB4977101	1	ヒザアゲヨコジクL	KNEE LIFTER SHAFT L	
20	149578020	2	ヨコジクブツシュ	BUSH	
21	146293001	1	トメワE10	RETAINING RING E10	
22	0A4401006	7	+ナベザクミ4X10DA	SCREW PAN (S/P WASHER) M4X10	
23	0A4402006	3	+ナベザクミ4X20DA	SCREW PAN (S/P WASHER) M4X20	
24	SB4975001	1	コネクタトリツケイタ	CONNECTOR SETTING PLATE	
25	0A4401006	2	+ナベザクミ4X10DA	SCREW PAN (S/P WASHER) M4X10	
26	SB3665001	1	セメントR40/220	CEMENT RESISTOR ASSY 40/220	
27	0A4401006	2	+ナベザクミ4X10DA	SCREW PAN (S/P WASHER) M4X10	
28	SB3837001	1	ワイヤークリップ	WIRE CLIP	
29	0A4401006	4	+ナベザクミ4X10DA	SCREW PAN (S/P WASHER) M4X10	
30	J04164001	1	オメガロックOLS-80	CLAMP OLS-80	
31	SB4974101	1	BOXカバー	BOX COVER	
32	SB3872001	2	BOXカバーピン	BOX COVER PIN	
33	SB4155001	4	バンド	BAND	
34	SB5035201	1	コネクタキャップ	CONNECTOR CAP	
35	0A4401006	2	+ナベザクミ4X10DA	SCREW PAN (S/P WASHER) M4X10	
36	S37060001	1	ア-スマーク	LABEL, GROUNDING	
37	0A4401006	2	+ナベザクミ4X10DA	SCREW PAN (S/P WASHER) M4X10	
38	SA9725001	1	ラベルカンデン6カコク	LABEL ELECTRICAL SHOCK 36X150	
39	SA9957002	1	ワ-ニングマ-ク	INJURY MARK	
			<欧州向用>	<For Europe>	
40	SB6402001	1	CEフィルタ フクロクミ	CE FILTER BAG ASSY	
41	SA9564001	1	CEフィルターケース	CE FILTER CASE	
42	SB6391001	1	CEフィルタキバンクミ	CE FILTER PCB ASSY	
43	200190001	5	ステツプル 10X20	STAPLE 10X20	
44	032461606	4	+2マルモク45X16	WOOD SCREW ROUND 2 M4.5X16	
45	S52164000	2	コアNFC-28	CORE:NFC-28	
46	0A5401005	2	+2ナベザクミ4X10DB	SCREW PAN (S/P WASHER) M4X10	

N1. コントロールボックス関係 / Control box

< 欧州向用 / For Europe >

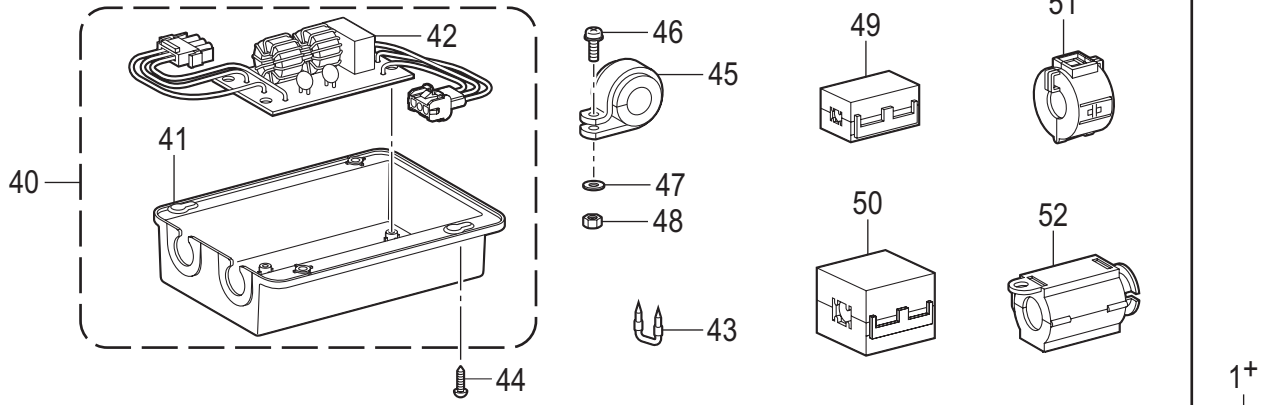

1+

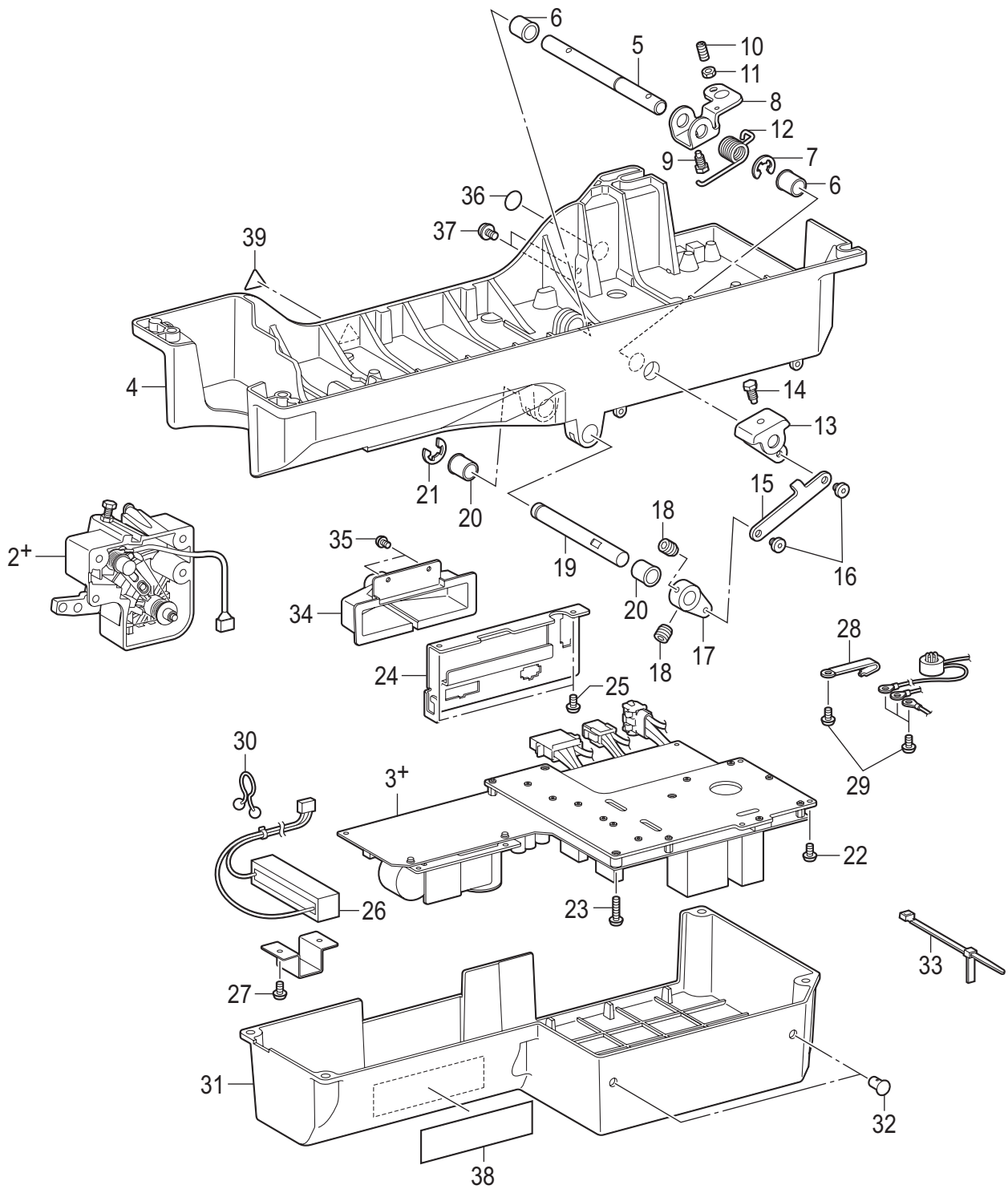

N1. コントロールボックス関係 / Control box

REF.NO	CODE	QTY	品名	NAME OF PARTS	RM
47	025040236	2	ヒラザガネチュウ4	WASHER PLAIN M4	
48	021400106	2	1シュナット4	NUT 1 M4	
49	S52162000	1	コアNF-65	CORE, NF-65	
50	S52163000	4	コアNF-130	CORE, NF-130	
51	SB4803001	2	コアK3NFR-10BK2	CORE:K3NFR-10BK2	
52	J02729001	1	EMCコア E2130MRC	EMC CORE E2130MRC	

< 米州向用 / For the Americas >

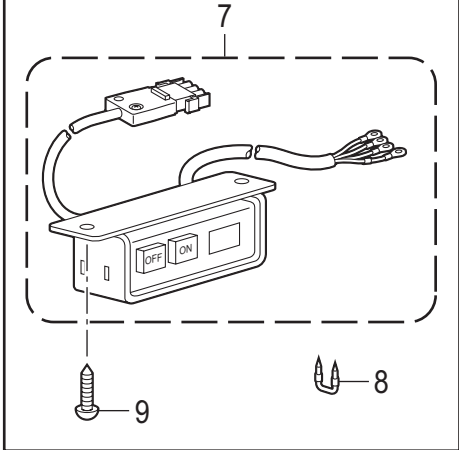

1+

< 単相 100V / 110V 用
For Single phase 100V / 110V >

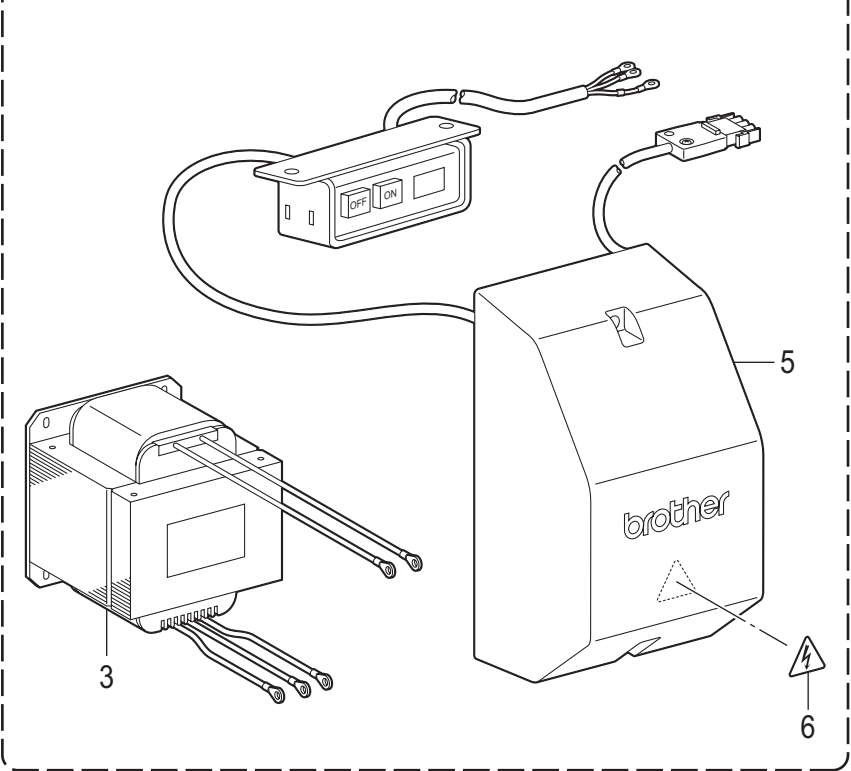

2+

< 三相 380V / 400V 用
For Three phase 380V / 400V >

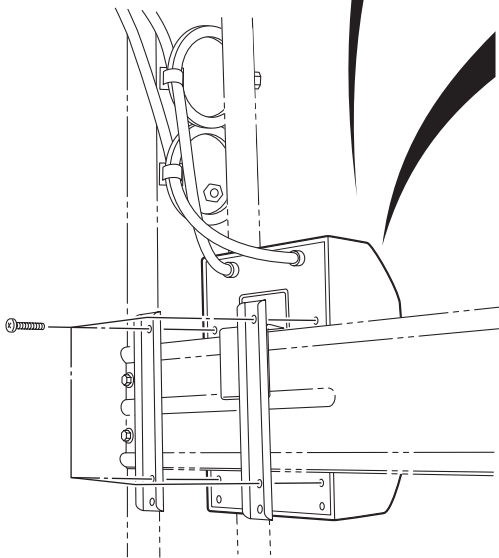
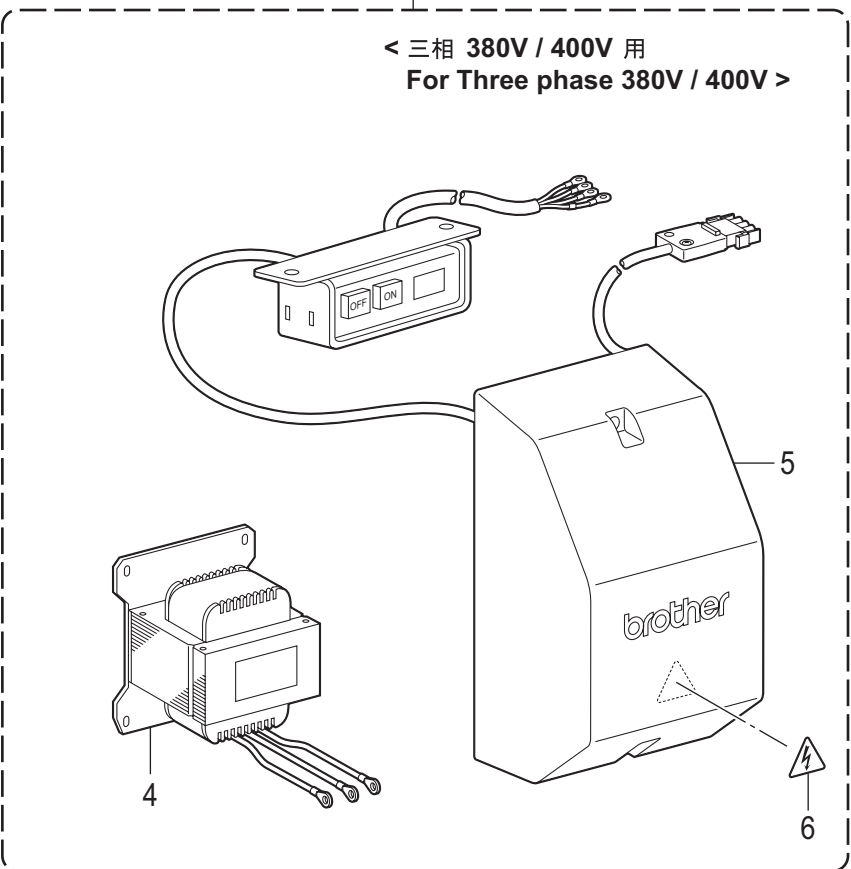

N2. コントロールボックス関係 / Control box

REF.NO	CODE	Q'TY	品名	NAME OF PARTS	RM
1+	BMP3010-0000000-AST1	1	<100V用> トランスボックス	<For 100V> TRANSFORMER BOX	
1+	BMP3010-0000000-2ST1	1	<110V用> トランスボックス	<For 110V> TRANSFORMER BOX	
2+	BMP3010-0000000-3ST4	1	<380V用> トランスボックス	<For 380V> TRANSFORMER BOX	
2+	BMP3010-0000000-4ST4	1	<400V用> トランスボックス	<For 400V> TRANSFORMER BOX	
3	SA9923101	1	<単相 100V/110V用> トランス 100/220V	<For single phase 100V/110V> TRANSFORMER 100/110/220V	
4	SA9901101	1	<三相 380V/400V用> トランス 400/230V	<For three phase 380V/400V> TRANSFORMER 400/230V	
5	SA9896001	1	トランスBOXカバー	TR BOX COVER	
6	SA9914001	1	ラベルカンデン25X28	LABEL ELECTRICAL SHOCK 25X28	
7	SB4531001	1	<米州向用> SWBOX フクロクミ	<For the Americas> SWBOX BAG ASSY	
8	200190001	5	ステツプル 10X20	STAPLE 10X20	
9	032461606	2	+2マルモク45X16	WOOD SCREW ROUND 2 M4.5X16	

P. 逆転スイッチ関係 / Quick reverse switch mechanism

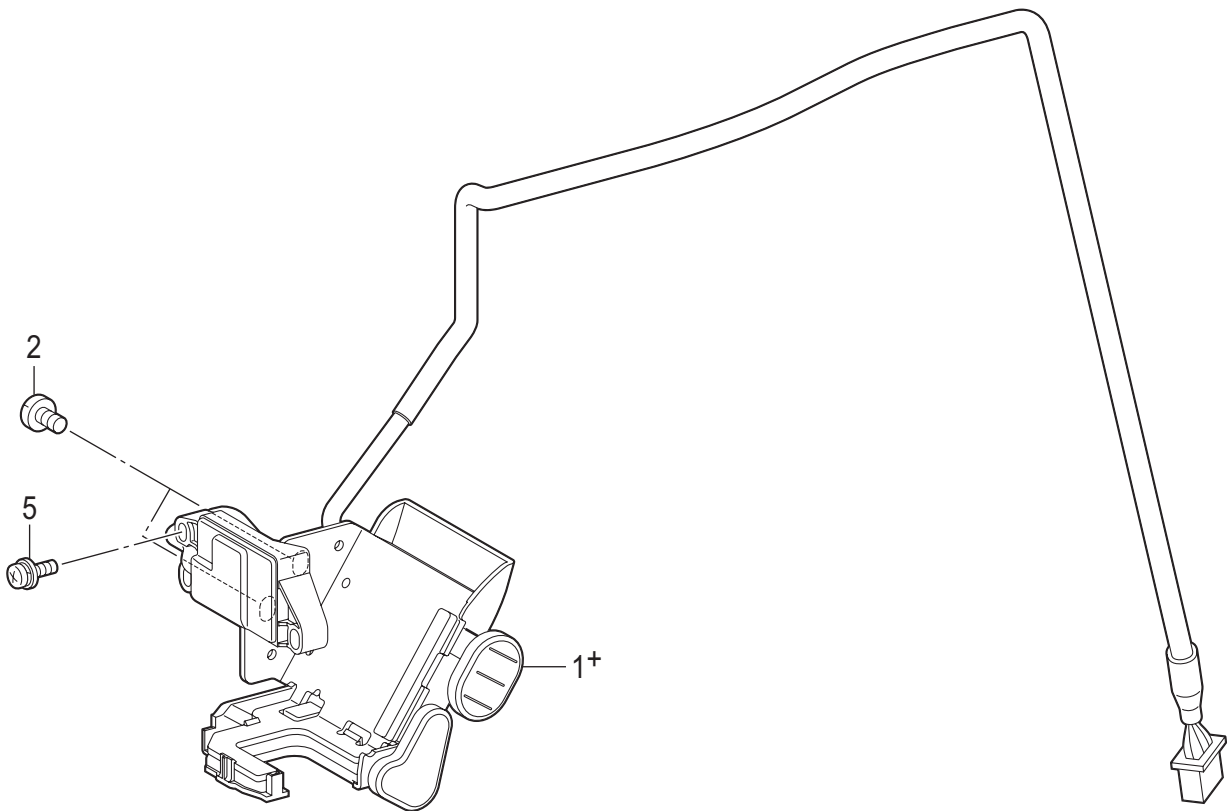
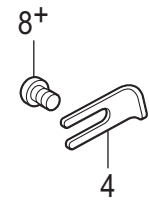
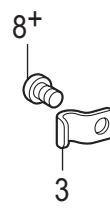
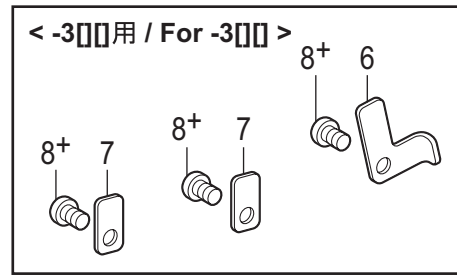
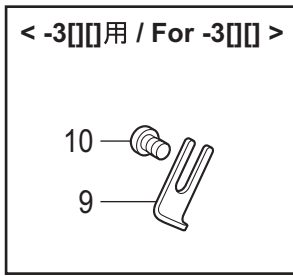

P. 逆転スイッチ関係 / Quick reverse switch mechanism

REF.NO	CODE	QTY	品名	NAME OF PARTS	RM
1+	SB6237101	1	<中国向用以外> スイッチクミP EX	<Except China> SWITCH ASSY P EX	
1+	SB5663401	1	<中国向用> スイッチクミP	<For China> SWITCH ASSY P	
2	060501016	2	バインド5X10	SCREW BIND M5X10	
3	SA2689101	1	コードオサエ	CORD HOLDER	
4	SB5025001	1	コードホルダD	CORD HOLDER D	
5	0A4401606	3	+ナベザクミ4X16DA	SCREW PAN (S/P WASHER) M4X16	
6	SB5024001	1	<-3□□用> コードオサエU	<For -3□□> CORD HOLDER U	
7	SB5028001	2	コードオサエ	CORD HOLDER	
8+	062500816	5	ナベコ5X8	SCREW PAN M5X8	
8+	062500816	2	<-4□□用> ナベコ5X8	<For -4□□> SCREW PAN M5X8	
9	SB5025001	1	<-3□□用> コードホルダD	<For -3□□> CORD HOLDER D	
10	062500816	1	ナベコ5X8	SCREW PAN M5X8	

< 日本、輸出一般向用 / For Japan and General export >
< 中国向用 / For China >

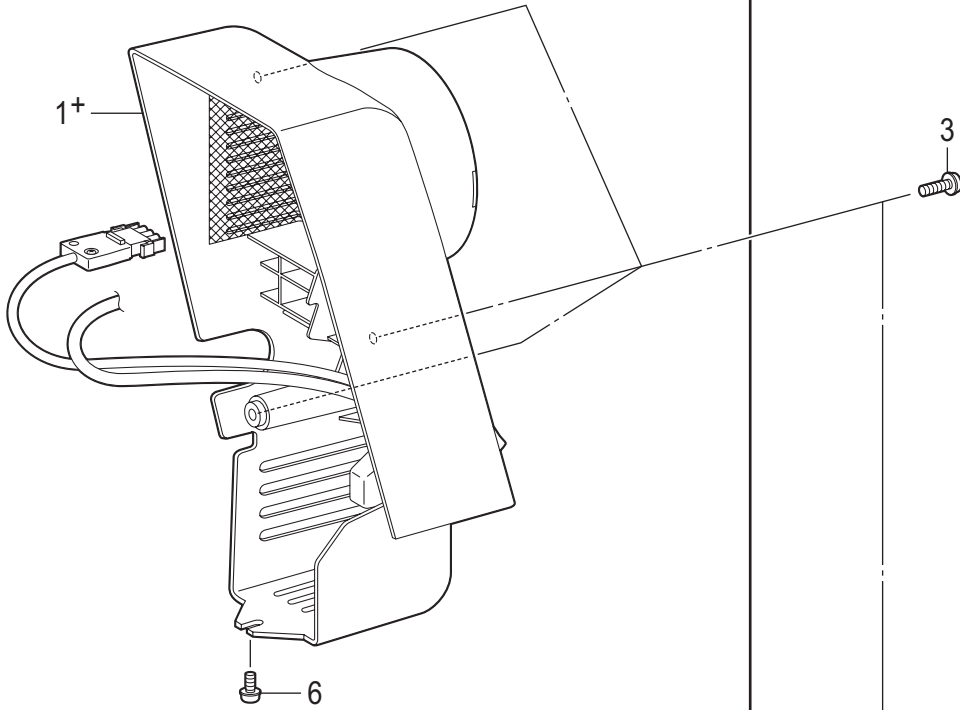

< 欧州、米州向用 / For Europe and the Americas >

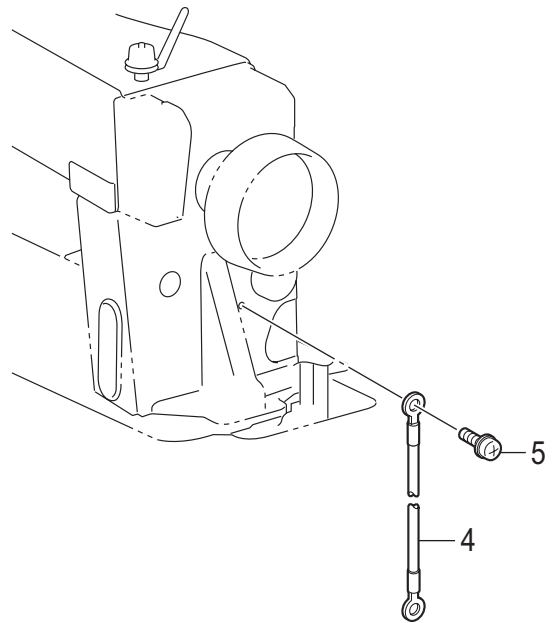
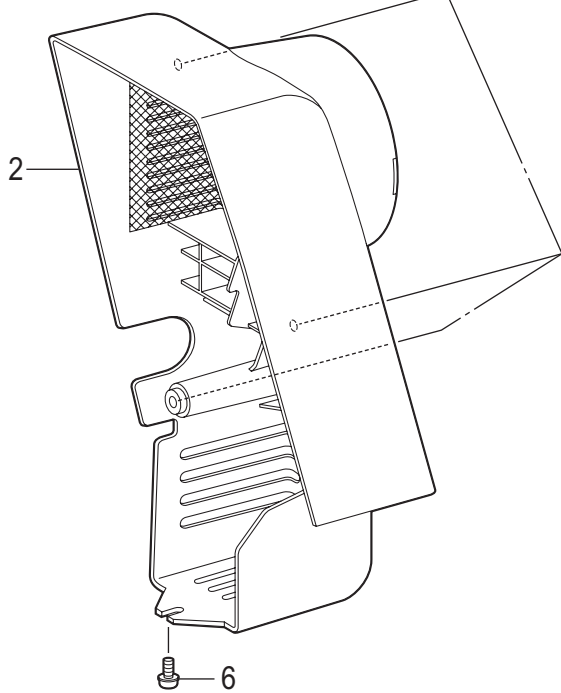

Q. モーターカバー関係 / Motor cover

REF.NO	CODE	QTY	品名	NAME OF PARTS	RM
1+	SB5645101	1	<日本、輸出一般向用> プーリーカバークミJ/A	<For Japan and General export> PULLEY COVER ASSY J/A	
1+	SB5267101	1	<中国向用> プーリーカバークミC	<For China> PULLEY COVER ASSY C	
2	SB5646101	1	<欧州、米州向用> プーリーカバーU/E	<For Europe and the Americas> PULLEY COVER U/E	
3	0A4501606	3	+ナベザクミ5X16DA	SCREW PAN (S/P WASHER) M5X16	
4	SB3621001	1	グラウンドワイヤ	GROUND WIRE	
5	0A4401006	1	+ナベザクミ4X10DA	SCREW PAN (S/P WASHER) M4X10	
6	0A5501206	1	+ナベザクミ5X12DB	SCREW PAN (S/P WASHER) M5X12	

T. 操作パネル関係 / Operation panel

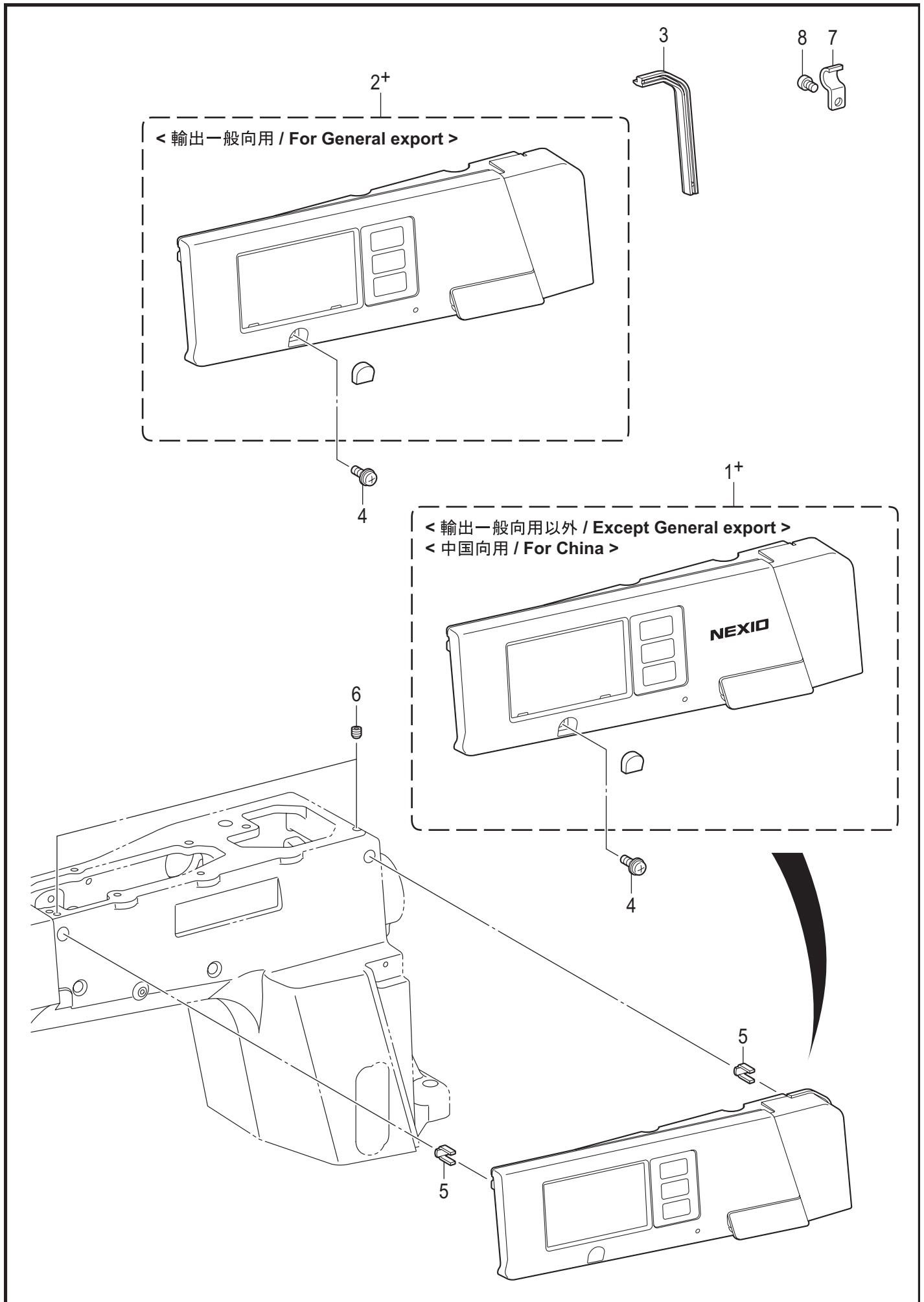

T. 操作パネル関係 / Operation panel

REF.NO	CODE	QTY	品名	NAME OF PARTS	RM
			<輸出一般向用以外> <中国向用>	<Except General export> <For China>	
1+	SB5987001	1	パネルクミホキュウロゴアリ	PANEL ASSY SUPPLY LOGO	
			<輸出一般向用>	<For General export>	
2+	SB6353001	1	パネルクミホキュウロゴナシ	PANEL ASSY SUPPLY W/O LOGO	
3	SB5045001	1	パネルフチゴム	EDGE COVER	
4	0A5401206	1	+ナベザクミ4X12DB	SCREW PAN (S/P WASHER) M4X12	
5	SB3655001	2	パネルサポート	PANEL SUPPORT	
6	012500536	2	アナヒラ5X5	SET SCREW SOCKET (FT) M5X5	
7	140647121	2	コードオサエ	CORD HOLDER	
8	062400816	2	ナベコ4X8	SCREW PAN M4X8	

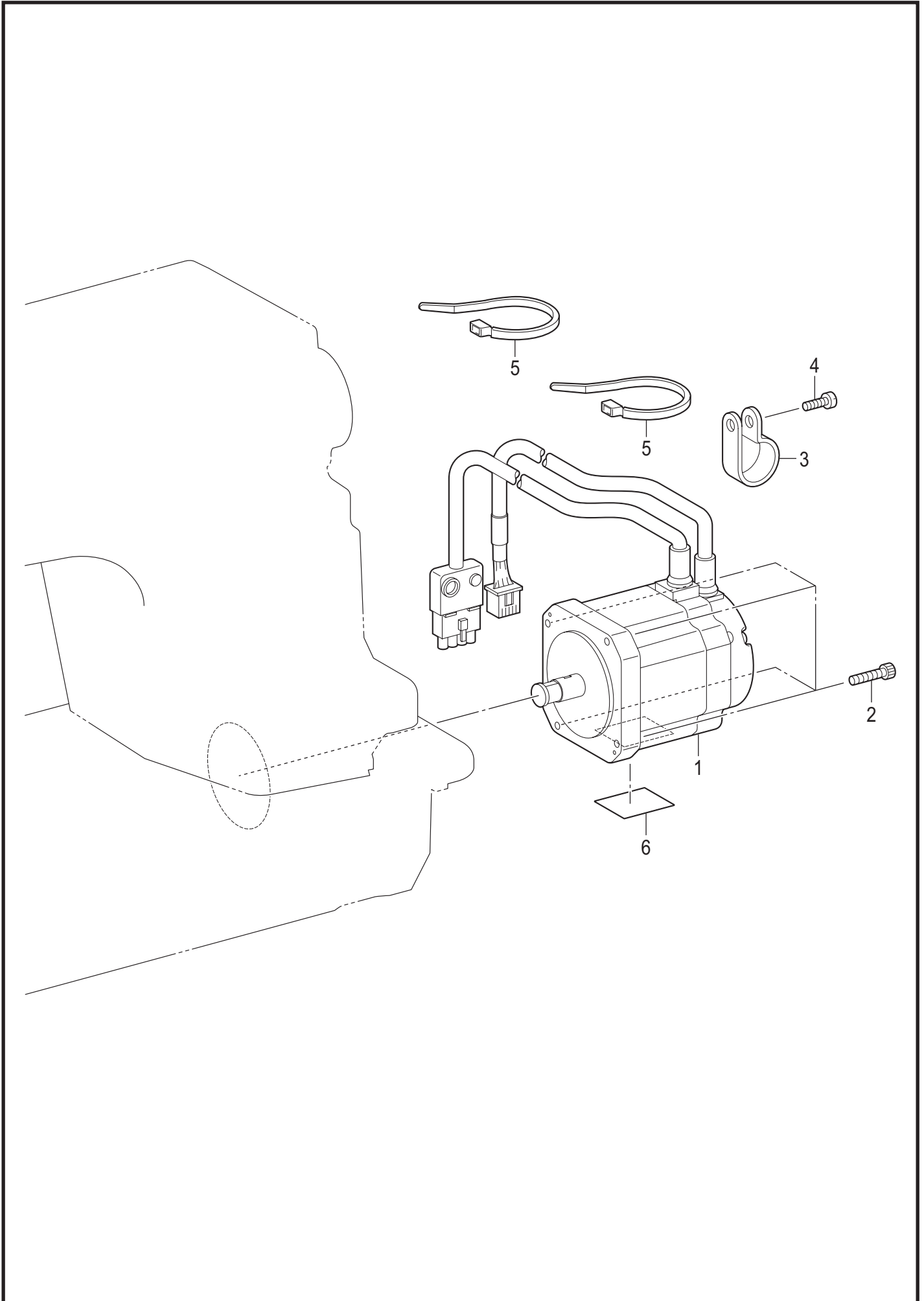

U. モーター関係 / Motor mechanism

REF.NO	CODE	QTY	品名	NAME OF PARTS	RM
1	SB5005201	1	モーターDR-7138B-501	MOTOR DR-7138B-501	
2	018402036	4	アナボルト4X20	BOLT SOCKET M4X20	
3	SB4096001	1	コードホルダ#12	CORD HOLDER #12	
4	062501216	1	ナベコ5X12	SCREW PAN M5X12	
5	218859001	2	バインダM150	BINDER M150	
6	SA4224001	1	マークチュウイ30X40	MARK ATTENTION 30X40	

V. 付属品関係 / Accessories

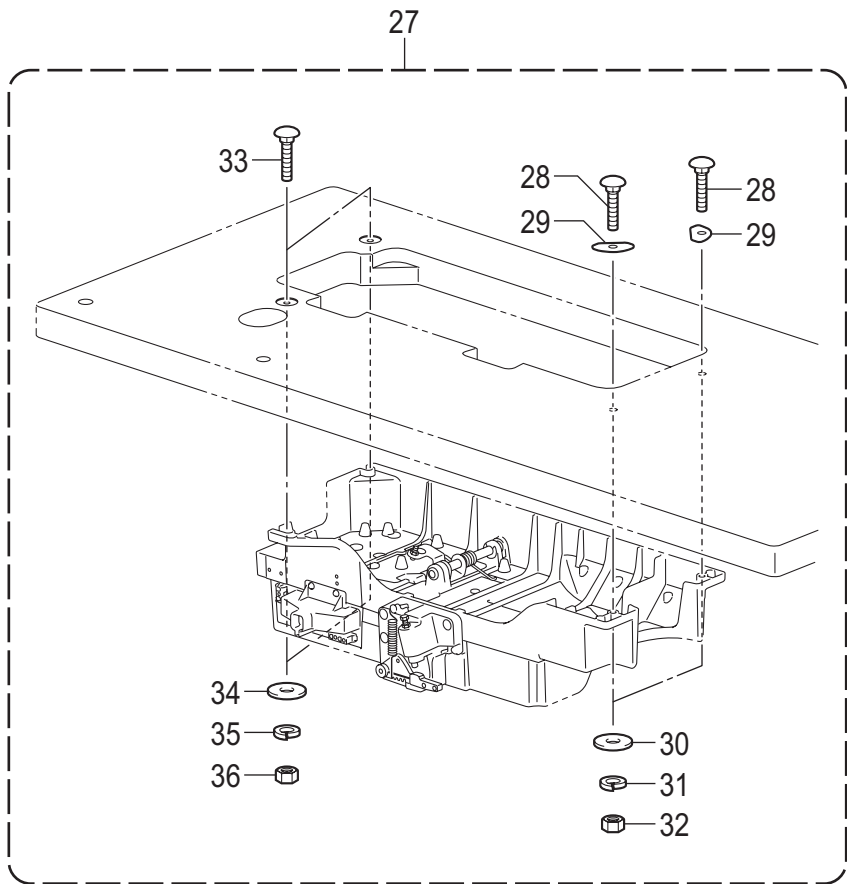
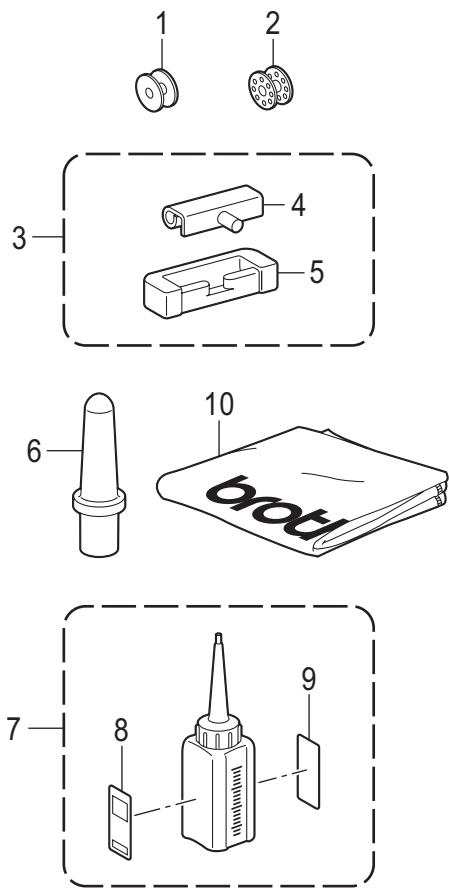

< オプション部品 / Option parts >

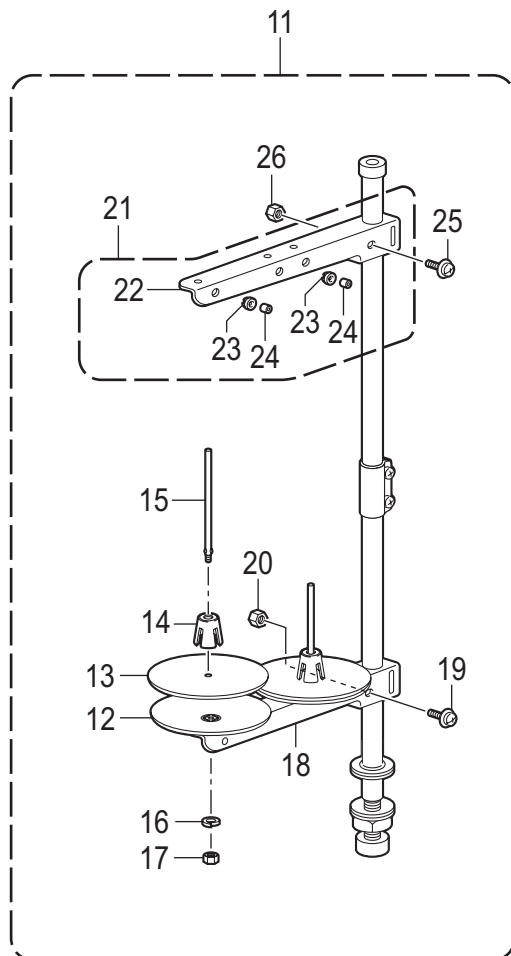
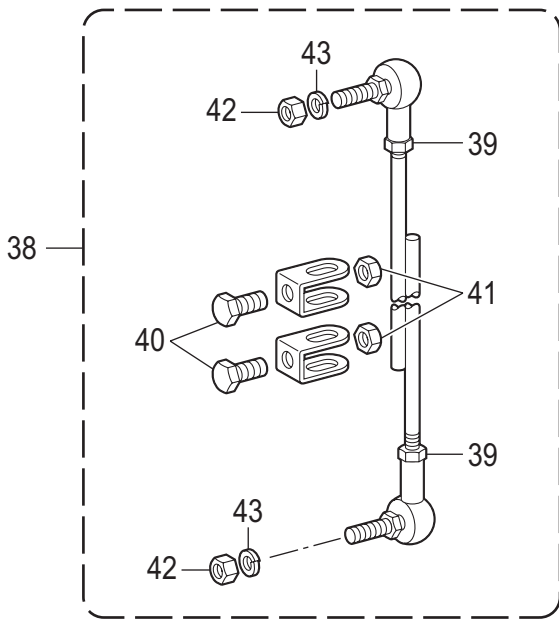
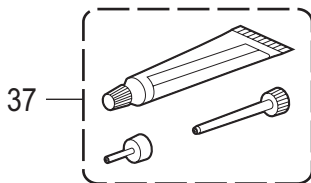

V. 付属品関係 / Accessories

REF.NO	CODE	QTY	品名	NAME OF PARTS	RM
1	146290001	1	<-□□3用> ボビン	<For -□□3> BOBBIN	
2	117132001	1	<-□□05用> ボビン	<For -□□05> BOBBIN	
3	SB5633001	1	ラバーヒンジクミ	RUBBER HINGE ASSY	
4	SB3627001	2	トウブヒンジ	HEAD HINGE	
5	SB3628001	2	トウブヒンジウケゴム	RUBBER CUSHION	
6	SB5046001	1	マクラ	HEAD REST	
7	SA8239201	1	オイルタンククミ	OIL TANK ASSY	
8	SB1270001	1	オイルケイコクラベル エイブン	OIL WARNING LABEL EN	
9	SB1271001	1	オイルケイコクラベル ワブン	OIL WARNING LABEL JP	
10	144226001	1	トウブカバー	HEAD COVER	
11	SB3928001	1	イトタテダイクミ2DR	COTTON STAND ASSY 2DR	
12	S51283001	2	ウケザラ	SPOOL STAND BASE	
13	SB4114001	2	スプールマット	SPOOL MAT	
14	S51282101	2	スプールクツシヨン	SPOOL CUSHION	
15	150179023	2	スプールジクB	SPOOL SHAFT B	
16	SB4117001	2	バネザガネ2-5	WASHER SPRING 2-5	
17	SB4119001	2	2シュナツト5	NUT 2 M5	
18	S02778022	1	スプールホルダー2	SPOOL HOLDER 2	
19	S37037002	1	ナベコヒラザ5X32	SCREW PAN (S/P WASHER) M5X32	
20	SB4118001	1	1シュナツト5	NUT 1 M5	
21	S02786002	1	スレツドハンガークミ2	THREAD HANGER ASSY 2	
22	S02787002	1	スレツドハンガー2	THREAD HANGER 2	
23	150183000	2	イトカケハンガーダイ	THREAD HANGER BASE	
24	142990001	2	スレツドブツシュ	THREAD BUSH	
25	SB4120001	1	ナベコヒラザM5X14	SCREW PAN(S/P WASHER) M5X14	
26	SB4118001	1	1シュナツト5	NUT 1 M5	
27	SB5634001	1	カクネクミ	BOLT SQUARE ASSY	
28	SB5047001	2	カクネボルト6X45	BOLT SQUARE M6X45	
29	SB5048001	2	シキイタ	SETTING PLATE	
30	025060332	2	ヒラザガネダイ6	WASHER PLAIN L 6	
31	028060242	2	バネザガネ2-6	WASHER SPRING 2-6	
32	021060106	2	1シュナツト6	NUT 1 M6	
33	SA9893001	2	カクネボルト8X65	BOLT M8X65	
34	SB4243001	2	ヒラザガネダイ8	WASHER PLAIN L 8	
35	028080242	2	バネザガネ2-8	WASHER SPRING 2-8	
36	021080202	2	2シュナツト8	NUT 2 M8	
37	SA8837001	1	<オプション部品> グリスクミ	<OPTION PARTS> GREASE UNIT	
38	S40765001	1	レンケツカンクミ	CONNECTING ROD ASSY	
39	021060103	2	1シュナツト6	NUT 1 M6	
40	017081603	2	ボルト8X16	BOLT 8X16	
41	021080103	2	1シュナツト8	NUT 1 M8	
42	S36119021	2	1シュナツト6	NUT 1 M6	
43	S36121021	2	バネザガネ2-6	WASHER SPRING 2-6	

Sp1. 仕様別部品一覧表 (日本向) / Different parts list (For Japan)

REF. NO.	品名 / Name of parts	仕様 / Specification	
		微量給油タイプ / Minimum lubrication type	
		-[]03	-[]05
		中厚物用 / Medium-weight materials	厚物用 / Heavy-weight materials
B-23	針棒 / Needle bar	SA9353001	SA9641001
B-28	ミシン針 / Needle	100265031	100265042
B-37	針板 / Needle plate	S29645001	SB5648001
C-11	押え組 / Presser foot assy	153037201	145157101
D-1	送り歯 / Feed dog	S02742001	S02743001

REF. NO.	品名 / Name of parts	仕様 / Specification	
		セミドライタイプ / Semi dry type	
		-[]33	
		中厚物用 / Medium-weight materials	
B-23	針棒 / Needle bar	SA9642101	
B-28	ミシン針 / Needle	100265031	
B-37	針板 / Needle plate	S29645001	
C-11	押え組 / Presser foot assy	153037201	
D-1	送り歯 / Feed dog	S02742001	

Sp2. 仕様別部品一覧表 (米州向、中国向、輸出一般向) /
 Different parts list (For the Americas, China and General export)

REF. NO.	品名 / Name of parts	仕様 / Specification	
		微量給油タイプ / Minimum lubrication type	
		-[]03	-[]05
		中厚物用 / Medium-weight materials	厚物用 / Heavy-weight materials
B-23	針棒 / Needle bar	SA9353001	SA9641001
B-28	ミシン針 / Needle	100265034	100265042
B-37	針板 / Needle plate	111859301	150792101
C-11	押え組 / Presser foot assy	153037201	150789101
D-1	送り歯 / Feed dog	SA2345101	SB5225001

REF. NO.	品名 / Name of parts	仕様 / Specification	
		セミドライタイプ / Semi dry type	
		-[]33	
		中厚物用 / Medium-weight materials	
B-23	針棒 / Needle bar	SA9642101	
B-28	ミシン針 / Needle	100265034	
B-37	針板 / Needle plate	111859301	
C-11	押え組 / Presser foot assy	153037201	
D-1	送り歯 / Feed dog	SA2345101	

Sp3. 仕様別部品一覧表 (欧州向) / Different parts list (For Europe)

REF. NO.	品名 / Name of parts	仕様 / Specification			
		微量給油タイプ / Minimum lubrication type			
		-□03		-□05	
		中厚物用 / Medium-weight materials		厚物用 / Heavy-weight materials	
		送り歯(3枚歯) / For 3ROW	送り歯(4枚歯) / For 4ROW	送り歯(3枚歯) / For 3ROW	送り歯(4枚歯) / For 4ROW
B-23	針棒 / Needle bar	SA9731001	←	SA9641001	←
B-28	ミシン針 / Needle	107415011	107415014		107415022
B-37	針板 / Needle plate	100266101	111859301		150792101
C-15	押え組 / Presser foot assy	SA8102001	←	SA8103001	←
D-1	送り歯 / Feed dog	S02742001	SA2345101		SB5225001

REF. NO.	品名 / Name of parts	仕様 / Specification			
		セミドライタイプ / Semi dry type			
		-□33			
		中厚物用 / Medium-weight materials			
		送り歯(3枚歯) / For 3ROW	送り歯(4枚歯) / For 4ROW		
B-23	針棒 / Needle bar	SA9640101	←		
B-28	ミシン針 / Needle	107415011	107415014		
B-37	針板 / Needle plate	100266101	111859301		
C-15	押え組 / Presser foot assy	SA8102001	←		
D-1	送り歯 / Feed dog	S02742001	SA2345101		

Ga1. ゲージ部品一覧表 (中厚物用 : 3枚歯) / Gauge parts list (Medium-weight materials : 3ROW)

3枚歯 / 3ROW

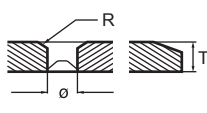
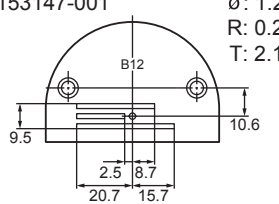
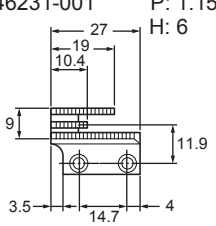
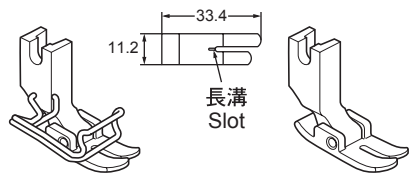
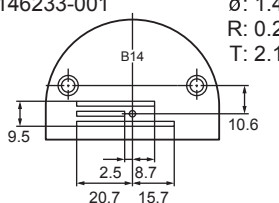
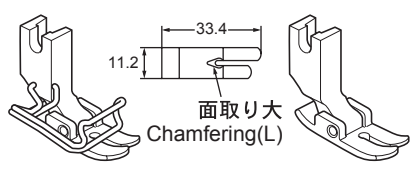
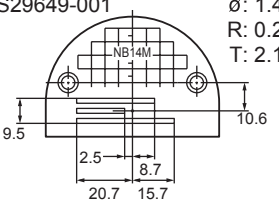
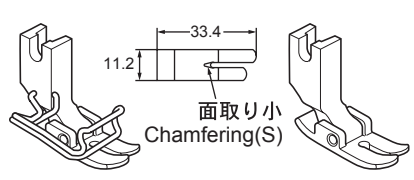
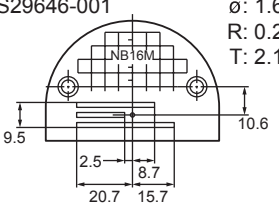
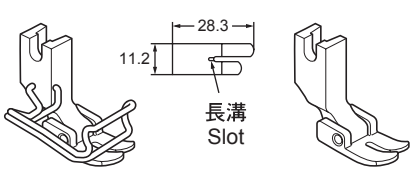
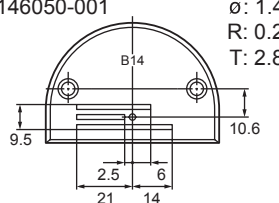
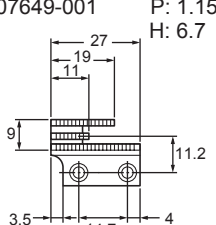
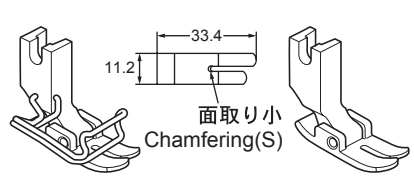
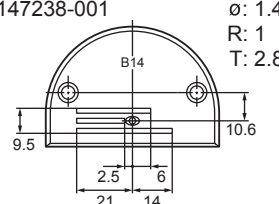
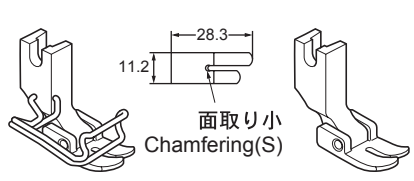
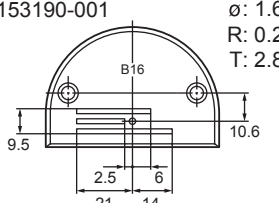
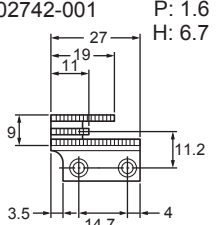
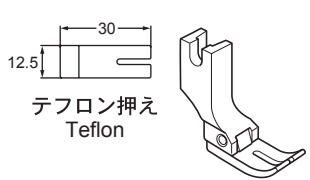
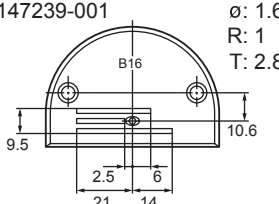
用途 Application	針板 Needle plate		送り歯 Feed dog	押え組 Presser foot assy		
	記号 Mark					
中厚物用 Medium-weight materials	B12	153147-001 	146231-001 P: 1.15 H: 6 	SA8102-001	153037-201 	
	B14	146233-001 		SA8105-001	113280-121 	
	NB14M	S29649-001 		SA8108-001	147531-101 	
	NB16M	S29646-001 		SA8109-001	111856-101 	
	B14	146050-001 		S07649-001 P: 1.15 H: 6.7 	SA8106-001	140957-101 
	B14	147238-001 		SA8107-001	143711-101 	
	B16	153190-001 		S02742-001 P: 1.6 H: 6.7 	S01904-101 	
	B16	147239-001 				

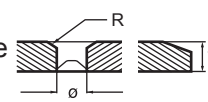
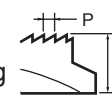
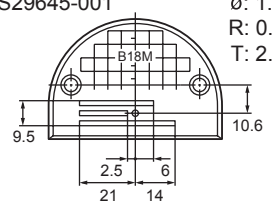
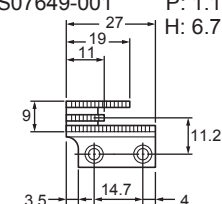
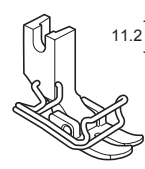
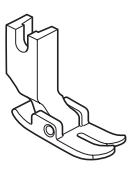
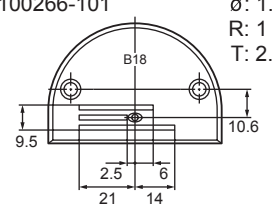
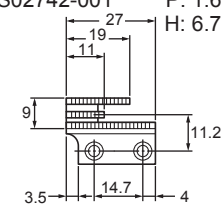
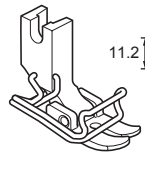
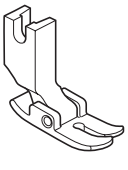
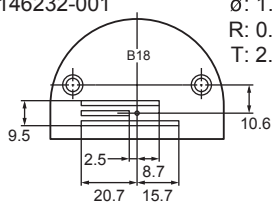
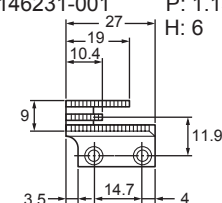
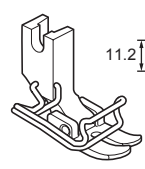
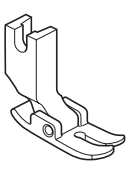
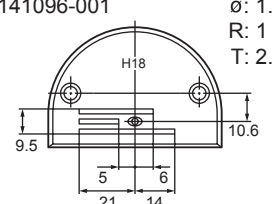
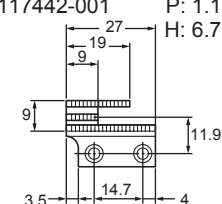
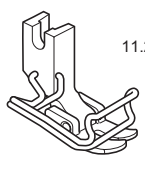
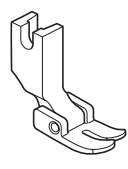
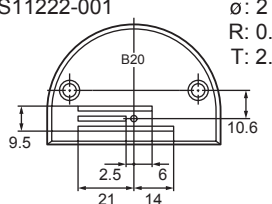
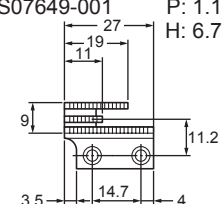
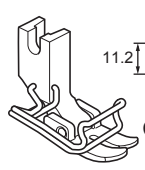
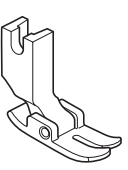
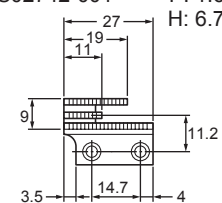
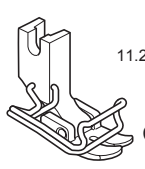
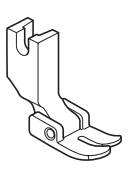
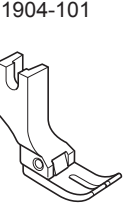

Ga2. ゲージ部品一覧表 (中厚物用 : 3枚歯) / Gauge parts list (Medium-weight materials : 3ROW)

3枚歯 / 3ROW

用途 Application	針板 Needle plate		送り歯 Feed dog	押え組 Presser foot assy	
	記号 Mark				
中厚物用 Medium-weight materials	B18M	S29645-001  ø: 1.8 R: 0.2 T: 2.8	S07649-001  P: 1.15 H: 6.7	SA8102-001 	153037-201  長溝 Slot
	B18	100266-101  ø: 1.8 R: 1 T: 2.8	S02742-001  P: 1.6 H: 6.7	SA8105-001 	113280-121  面取り大 Chamfering(L)
	B18	146232-001  ø: 1.8 R: 0.2 T: 2.1	146231-001  P: 1.15 H: 6	SA8108-001 	147531-101  面取り小 Chamfering(S)
	H18	141096-001  ø: 1.8 R: 1 T: 2.8	117442-001  P: 1.15 H: 6.7	SA8109-001 	111856-101  長溝 Slot
	B20	S11222-001  ø: 2 R: 0.2 T: 2.8	S07649-001  P: 1.15 H: 6.7	SA8106-001 	140957-101  面取り小 Chamfering(S)
			S02742-001  P: 1.6 H: 6.7	SA8107-001 	143711-101  面取り小 Chamfering(S)
				S01904-101  テフロン押え Teflon	

Ga3. ゲージ部品一覧表 (厚物用 : 3枚歯) / Gauge parts list (Heavy-weight materials : 3ROW)

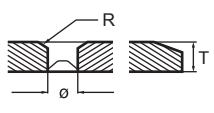
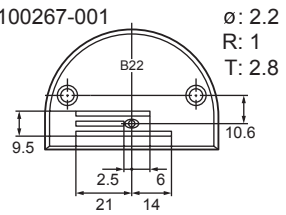
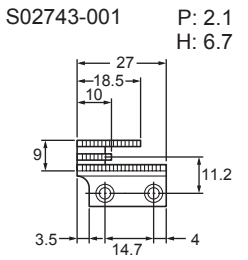
3枚歯 / 3ROW

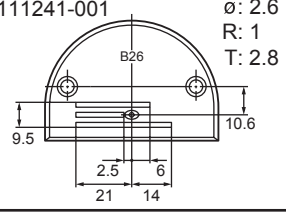
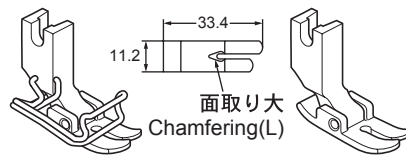
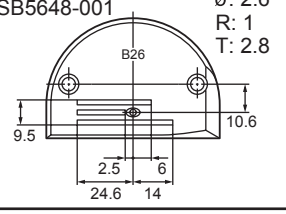
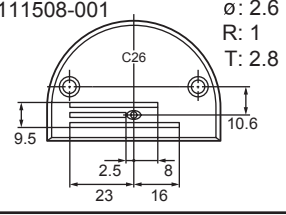
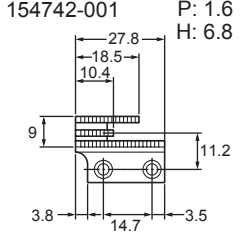
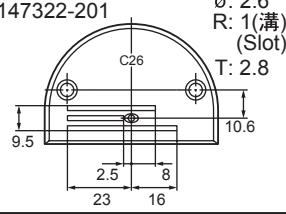
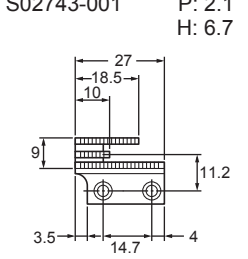
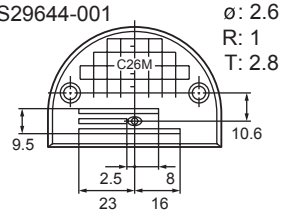
用途 Application	針板 Needle plate		送り歯 Feed dog	押え組 Presser foot assy	
	記号 Mark				
厚物用 Heavy-weight materials	B22			SA8104-001 145157-101  <p>針落ち部のみ 面取りあり These presser foot have chamfering corner on the needle location</p>	
	B26			SA8105-001 113280-121  <p>面取り大 Chamfering(L)</p>	
	B26				
	C26				
	C26				
	C26M				

- ◎ ネジ穴中心から歯部中心まで11.9mm の送り歯を使用する場合、水平送り台腕と上下送り台腕を0.7mm左側へ移動させて下さい。
- ◎ If a feed dog measuring 11.9mm from the screw hole center to tooth center is be use, shift the feed bar crank and feed lifting crank 0.7mm to the left .

Ga4. ゲージ部品一覧表 (中厚物用 : 4枚歯) / Gauge parts list (Medium-weight materials : 4ROW)

4枚歯 / 4ROW

用途 Application	針板 Needle plate		送り歯 Feed dog	押え組 Presser foot assy		
	記号 Mark					
中厚物用 Medium-weight materials	E12N1	S03882-201 $\phi: 1.2$ R: 1 T: 2.1	SA2345-101 P: 1.15 H: 6	SA8102-001	153037-201 	
	E14N1	159859-201 $\phi: 1.4$ R: 1(溝) T: 2.1		SA8105-001	113280-121 	
	E12	S01107-101 $\phi: 1.2$ R: 1 T: 2.8		S13684-001 P: 1.6 H: 6.7	SA8108-001	147531-101
					SA8109-001	111856-101
				送りピッチ 4mm 以下で使用 Use the feed dog and needle plate with a stitch length of 4mm or less		
	AB14N1	S02999-201 $\phi: 1.4$ R: 0.2 T: 2.1	S02748-001 P: 0.9 H: 6	SA8106-001	140957-101 	
	AB16N1	S03000-201 $\phi: 1.6$ R: 0.2 T: 2.1	S02744-001 P: 1.15 H: 6	SA8107-001	143711-101 	
					S01904-101 	

Ga5. ゲージ部品一覧表 (中厚物用 : 4枚歯) / Gauge parts list (Medium-weight materials : 4ROW)

4枚歯 / 4ROW

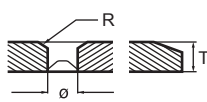
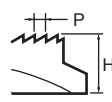
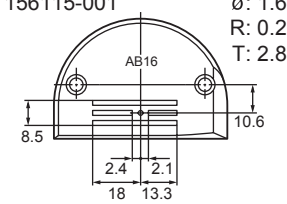
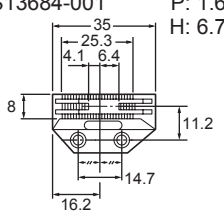
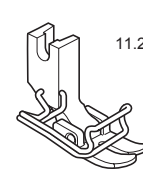
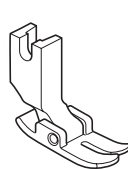
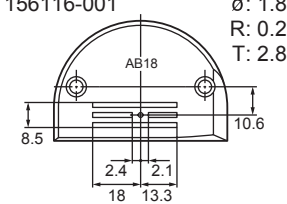
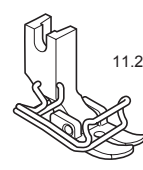
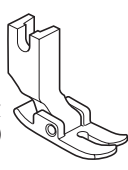
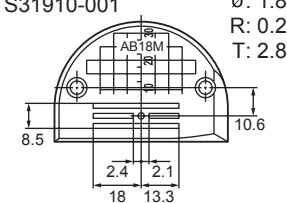
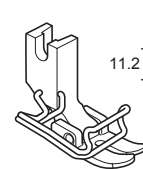
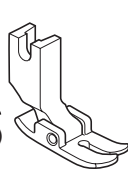
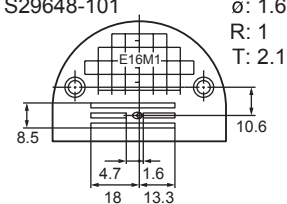
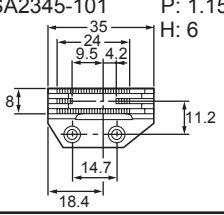
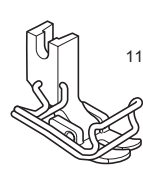
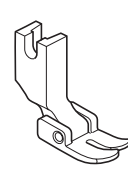
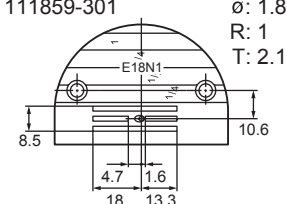
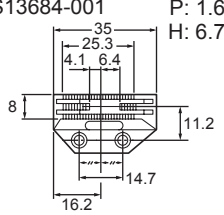
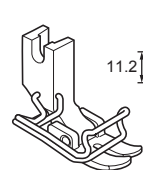
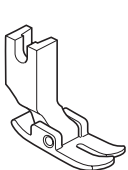
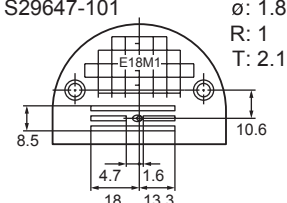
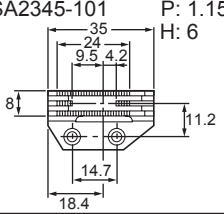
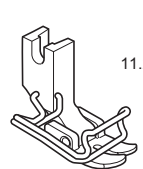
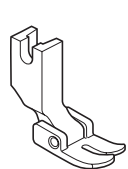
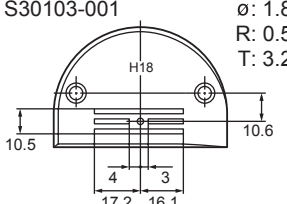
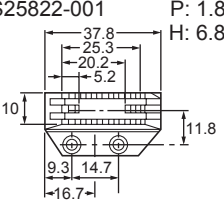
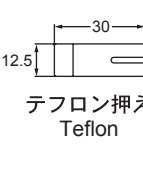
用途 Application	針板 Needle plate		送り歯 Feed dog	押え組 Presser foot assy	
	記号 Mark				
中厚物用 Medium-weight materials	AB16	156115-001  ø: 1.6 R: 0.2 T: 2.8	S13684-001  P: 1.6 H: 6.7	SA8102-001 	153037-201  長溝 Slot
	AB18	156116-001  ø: 1.8 R: 0.2 T: 2.8		SA8105-001 	113280-121  面取り大 Chamfering(L)
	AB18M	S31910-001  ø: 1.8 R: 0.2 T: 2.8		SA8108-001 	147531-101  面取り小 Chamfering(S)
	E16M1	S29648-101  ø: 1.6 R: 1 T: 2.1	SA2345-101  P: 1.15 H: 6	SA8109-001 	111856-101  長溝 Slot
	E18N1	111859-301  ø: 1.8 R: 1 T: 2.1	S13684-001  P: 1.6 H: 6.7	SA8106-001 	140957-101  面取り小 Chamfering(S)
	E18M1	S29647-101  ø: 1.8 R: 1 T: 2.1	SA2345-101  P: 1.15 H: 6	SA8107-001 	143711-101  面取り小 Chamfering(S)
	H18	S30103-001  ø: 1.8 R: 0.5 T: 3.2	S25822-001  P: 1.8 H: 6.8		S01904-101  テフロン押え Teflon

Ga6. ゲージ部品一覧表 (中厚物用 : 4枚歯) / Gauge parts list (Medium-weight materials : 4ROW)

4枚歯 / 4ROW

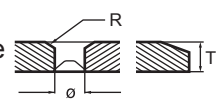
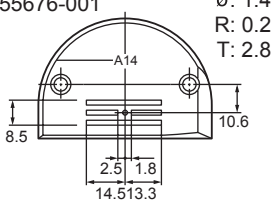
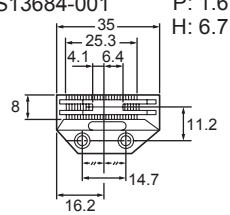
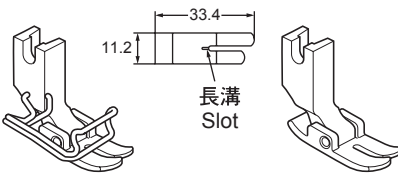
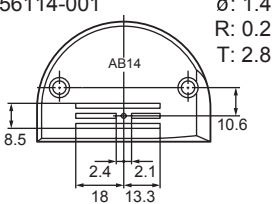
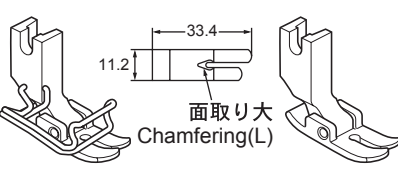
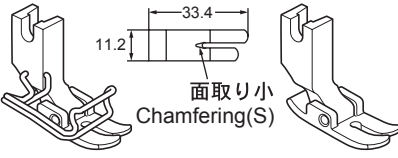
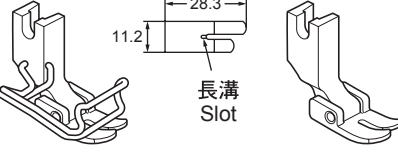
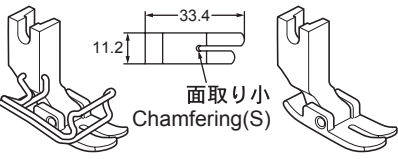
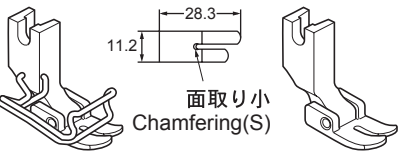
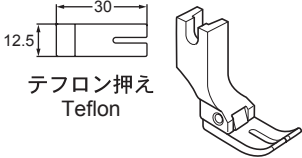
用途 Application	針板 Needle plate		送り歯 Feed dog	押え組 Presser foot assy	
	記号 Mark				
中厚物用 Medium-weight materials	A14	155676-001 	S13684-001 	SA8102-001 	153037-201
	AB14	156114-001 		SA8105-001 	113280-121
				SA8108-001 	147531-101
				SA8109-001 	111856-101
				SA8106-001 	140957-101
				SA8107-001 	143711-101
				S01904-101 	

Ga7. ゲージ部品一覧表 (厚物用 : 4枚歯) / Gauge parts list (Heavy-weight materials : 4ROW)

4枚歯 / 4ROW

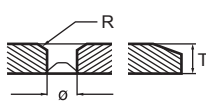
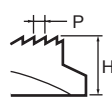
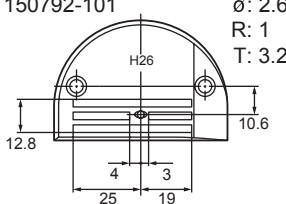
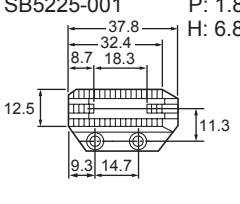
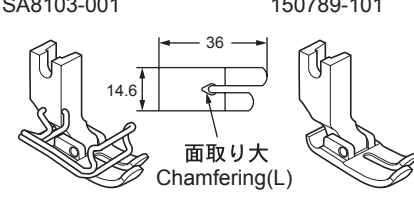
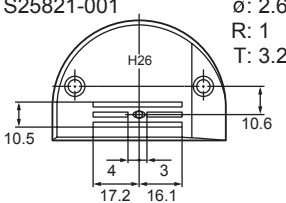
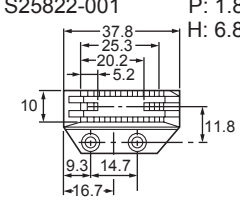
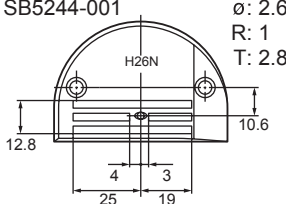
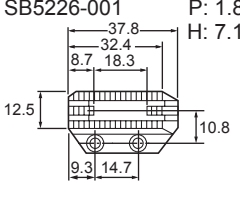



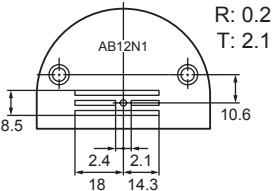
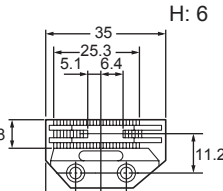
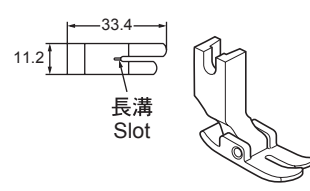
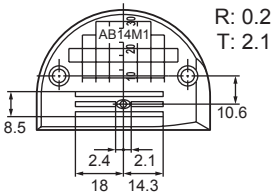

用途 Application	針板 Needle plate		送り歯 Feed dog	押え組 Presser foot assy
	記号 Mark			
厚物用 Heavy-weight Materials	H26	150792-101  ø: 2.6 R: 1 T: 3.2	SB5225-001  P: 1.8 H: 6.8	SA8103-001 150789-101  面取り大 Chamfering(L)
	H26	S25821-001  ø: 2.6 R: 1 T: 3.2	S25822-001  P: 1.8 H: 6.8	
	H26N	SB5244-001  ø: 2.6 R: 1 T: 2.8	SB5226-001  P: 1.8 H: 7.1	

Ga8. ゲージ部品一覧表 (難素材・新素材用 : 4枚歯) /
 Gauge parts list (Difficult-to-sew materials & Shin-gosen : 4ROW)

4枚歯 / 4ROW

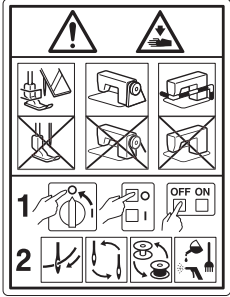
用途 Application	針板 Needle plate 記号 Mark	送り歯 Feed dog	押え組 Presser foot assy
難素材用 Difficult-to-sew materials	AB12N1 S38760-001  $\phi: 1.2$ $R: 0.2$ $T: 2.1$	S02748-001 P: 0.9 H: 6 	S35777-101  長溝 Slot
新素材用 Shin-gosen	AB14M1 S35776-101  $\phi: 1.4$ $R: 0.2$ $T: 2.1$		

Wa. 警告ラベル / Warning labels

警告ラベル / Warning labels	品名 / Name of parts	Size(mm)	Code
	<p>ラベル感電6ヶ国 Label electrical shock 36 X 150</p>	<p>36 X 150</p>	<p>SA9725-001</p>
	<p>ラベル感電 25 X 28 Label electrical shock 25 X 28</p>	<p>L=28.4</p>	<p>SA9914-001</p>
	<p>操作注意ラベル Label caution</p>	<p>56 X 43</p>	<p>SA9826-001</p>
	<p>ワーニングマーク Injury mark</p>	<p>L=16</p>	<p>SA9957-001</p>
	<p>ワーニングマーク Injury mark</p>	<p>L=25</p>	<p>SA9957-002</p>
	<p>アースマーク Label, grounding</p>	<p>φ 12</p>	<p>S37060-001</p>
	<p>マークチュウイ 30 X 40 Mark attention 30 X 40</p>	<p>30 X 40</p>	<p>SA4224-001</p>

Wa. 警告ラベル / Warning labels

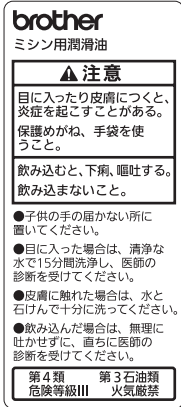
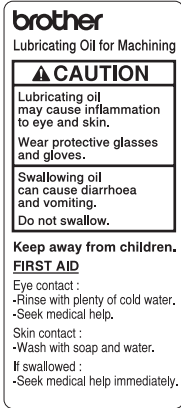
警告ラベル / Warning labels	品名 / Name of parts	Size(mm)	Code
 <p>brother ミシン用潤滑油</p> <p>▲ 注意</p> <p>目に入ったり皮膚につくと、炎症を起こすことがある。 保護めがね、手袋を使うこと。</p> <p>飲み込むと、下痢、嘔吐する。 飲み込まないこと。</p> <p>●子供の手の届かない所に置いてください。 ●目に入った場合は、清潔な水で15分間洗浄し、医師の診断を受けてください。 ●皮膚に触れた場合は、水と石けんで十分に洗ってください。 ●飲み込んだ場合は、無理に吐かせずに、直ちに医師の診断を受けてください。</p> <p>第4類 危険等級III 第3石油類 火気厳禁</p>	<p>オイル警告ラベル和文 Oil warning label JP</p>	<p>68 X 30</p>	<p>SB1271-001</p>
 <p>brother Lubricating Oil for Machining</p> <p>▲ CAUTION</p> <p>Lubricating oil may cause inflammation to eye and skin. Wear protective glasses and gloves.</p> <p>Swallowing oil can cause diarrhoea and vomiting. Do not swallow.</p> <p>Keep away from children. FIRST AID Eye contact : -Rinse with plenty of cold water. -Seek medical help. Skin contact : -Wash with soap and water. If swallowed : -Seek medical help immediately.</p>	<p>オイル警告ラベル英文 Oil warning label EN</p>	<p>68 X 30</p>	<p>SB1270-001</p>

CODE	REF.NO	Page	CODE	REF.NO	Page	CODE	REF.NO	Page	CODE	REF.NO	Page
004301016	K - 31	26	048120142	B - 43	6	0A5501206	Q - 6	42	143711101	Ga5	56
012060636	B - 19	4	048150142	B - 7	4	100022004	N1 - 11	34		Ga6	57
	F - 11	16	060300606	H - 41	22	100136001	H - 5	20	144226001	V - 10	48
	N1 - 18	34	060400516	M - 21	32	100265031	Sp1	49	144875001	G - 28	18
012400432	J - 8	24		M - 23	32	100265034	Sp2	50	145157101	Sp1	49
012400436	B - 15	4	060401016	D - 12	12	100265042	Sp1	49		Ga3	54
012500536	B - 21	4		K - 16	26		Sp2	50	145446001	H - 3	20
	B - 59	6	060401216	A - 11	2	100266101	Sp3	51		H - 18	20
	C - 21	8	060500616	H - 31	20		Ga2	53	145446002	J - 24	24
	D - 27	12	060501016	J - 22	24	100267001	Ga3	54	145737021	G - 10	18
	D - 29	12		J - 26	24	100402004	H - 16	20	146050001	Ga1	52
	H - 11	20		P - 2	40	100645003	K - 18	26	146231001	Ga1	52
	H - 33	20	062061616	J - 27	24	102630001	B - 22	4		Ga2	53
	J - 10	24	062300616	M - 4	32	104450101	A - 3	2	146232001	Ga2	53
	T - 6	44	062400616	A - 13	2	104821001	G - 16	18	146233001	Ga1	52
014300432	D - 5	12		K - 3	26	104833001	B - 27	4	146288021	M - 20	32
	D - 16	12	062400816	G - 6	18		C - 6	8	146290001	F - 23	16
014771032	K - 43	26		G - 33	18	105234003	K - 36	26		V - 1	48
017081603	V - 40	48		J - 13	24	107415011	Sp3	51	146293001	N1 - 7	34
018062036	K - 66	28		K - 47	26	107415014	Sp3	51		N1 - 21	34
018062536	K - 57	28		K - 49	26	107415022	Sp3	51	147238001	Ga1	52
018400532	C - 34	8		L - 3	30	110161004	L - 8	30	147239001	Ga1	52
018400636	K - 55	28		T - 8	44	110367001	B - 8	4	147322201	Ga3	54
018401436	D - 34	12	062401216	L - 5	30	110735022	M - 15	32	147531101	Ga1	52
018402036	U - 2	46	062500816	B - 34	4	111241001	Ga3	54		Ga2	53
018500836	L - 7	30		G - 8	18	111508001	Ga3	54		Ga4	55
018501036	K - 10	26		H - 36	20	111856101	Ga1	52		Ga5	56
018501436	D - 35	12		M - 24	32		Ga2	53		Ga6	57
	K - 29	26		M - 27	32		Ga4	55	148537101	K - 6	26
021060103	V - 39	48		P - 8+	40		Ga5	56		K - 12	26
021060106	V - 32	48		P - 10	40		Ga6	57	149287000	D - 39	12
021060306	C - 27	8	062501016	D - 11	12	111859301	Sp2	50	149578020	N1 - 6	34
	C - 29	8		K - 63	28		Sp3	51		N1 - 20	34
	C - 44	8	062501216	G - 4	18		Ga5	56	150179023	V - 15	48
	C - 47	10		G - 37	18	111863001	B - 24+	4	150183000	V - 23	48
	K - 60	28		G - 39	18	113280121	Ga1	52	150607000	A - 6	2
021080103	V - 41	48		K - 61	28		Ga2	53	150789101	Sp2	50
021080202	V - 36	48		U - 4	46		Ga3	54		Ga7	58
021350106	D - 31	12	081004070	C - 19	8		Ga4	55	150792101	Sp2	50
021400106	N1 - 48	36		J - 20	24		Ga5	56		Sp3	51
021400306	K - 19	26	081004870	F - 3	16		Ga6	57		Ga7	58
025040236	N1 - 47	36		G - 23	18	114561001	B - 40	6	151267001	B - 38	6
025040332	G - 34	18	081006670	G - 15	18	116922201	H - 17	20	151594001	B - 30	4
025060232	J - 16	24	081008070	G - 18	18	117132001	F - 24	16	153037201	Sp1	49
025060332	K - 67	28		G - 32	18		V - 2	48		Sp2	50
	V - 30	48	081025870	F - 5	16	117442001	Ga2	53		Ga1	52
025350132	C - 14	8	081029870	F - 6	16	140004001	B - 18	4		Ga2	53
026030136	M - 5	32	0A4401006	N1 - 22	34	140327001	G - 24	18		Ga4	55
026040236	C - 35	8		N1 - 25	34	140407001	C - 9	8		Ga5	56
	K - 2	26		N1 - 27	34	140553102	B - 29	4		Ga6	57
026050136	K - 51	28		N1 - 29	34	140647121	K - 48	26	153147001	Ga1	52
028060242	V - 31	48		N1 - 35	34		T - 7	44	153190001	Ga1	52
028080242	V - 35	48		N1 - 37	34	140957101	Ga1	52	154567000	K - 42	26
032461606	N1 - 44	34		Q - 5	42		Ga2	53	154742001	Ga3	54
	N2 - 9	38	0A4401606	H - 42	22		Ga4	55	155676001	Ga6	57
037300616	J - 19	24		P - 5	40		Ga5	56	156114001	Ga6	57
048030342	M - 16	32	0A4402006	N1 - 23	34		Ga6	57	156115001	Ga5	56
048040342	M - 17	32	0A4501206	G - 20	18	141096001	Ga2	53	156116001	Ga5	56
048050142	K - 52	28	0A4501606	Q - 3	42	141728001	C - 8+	8	159150000	A - 5	2
048050342	C - 25	8	0A5401005	N1 - 46	34	142990001	V - 24	48	159805001	H - 4	20
	J - 2	24	0A5401006	D - 37	12	143711101	Ga1	52		H - 19	20
048060342	B - 17	4		D - 40	12		Ga2	53	159859201	Ga4	55
048080142	D - 22	12	0A5401206	T - 4	44		Ga4	55	180018151	B - 39	6

索引 / Index

CODE	REF.NO	Page	CODE	REF.NO	Page	CODE	REF.NO	Page	CODE	REF.NO	Page
183388001	F - 19	16	S23651001	K - 37	26	SA2345101	Sp3	51	SA8109001	Ga6	57
183389001	F - 20	16	S25235001	B - 3	4		Ga4	55	SA8239201	V - 7	48
183390001	F - 21	16	S25236001	B - 4	4		Ga5	56	SA8837001	V - 37	48
200190001	N1 - 43	34	S25380601	G - 26	18	SA2378001	B - 48	6	SA8903001	C - 4	8
	N2 - 8	38	S25382001	G - 12	18	SA2422001	B - 13	4		F - 16	16
218859001	U - 5	46		G - 22	18	SA2689101	M - 25	32	SA8987001	G - 14	18
228475000	D - 38	12	S25434000	K - 39	26		P - 3	40	SA8989001	G - 13	18
BMP3010-0000000-2ST1			S25456001	M - 9	32	SA4146101	H - 6	20	SA9352001	M - 14	32
	N2 - 1+	38		M - 12	32	SA4224001	D - 41	12	SA9353001	Sp1	49
BMP3010-0000000-3ST4			S25821001	Ga7	58		U - 6	46		Sp2	50
	N2 - 2+	38	S25822001	Ga5	56		Wa1	60	SA9359001	C - 1+	8
BMP3010-0000000-4ST4				Ga7	58	SA5329001	K - 17	26	SA9523001	B - 41	6
	N2 - 2+	38	S29644001	Ga3	54	SA5810001	A - 4	2	SA9564001	N1 - 41	34
BMP3010-0000000-AST1			S29645001	Sp1	49	SA7239101	B - 20	4	SA9640101	Sp3	51
	N2 - 1+	38		Ga2	53	SA7242001	C - 5	8	SA9641001	Sp1	49
J02729001	N1 - 52	36	S29646001	Ga1	52	SA7257001	D - 20	12		Sp2	50
J04164001	N1 - 30	34	S29647101	Ga5	56	SA7271001	H - 40	22		Sp3	51
S01107101	Ga4	55	S29648101	Ga5	56	SA7272201	H - 34	20	SA9642101	Sp1	49
S01904101	Ga1	52	S29649001	Ga1	52	SA7275001	H - 15+	20		Sp2	50
	Ga2	53	S30103001	Ga5	56	SA7285101	K - 28	26	SA9684001	F - 9	16
	Ga4	55	S31006002	C - 16	8	SA7287001	K - 30	26	SA9716001	K - 50	26
	Ga5	56	S31032002	H - 21	20	SA7607101	C - 7	8	SA9725001	N1 - 38	34
	Ga6	57	S31910001	Ga5	56	SA7625001	B - 10+	4		Wa1	60
S02620401	H - 22	20	S32958000	B - 11	4	SA7626001	B - 10+	4	SA9731001	Sp3	51
S02742001	Sp1	49	S35776101	Ga8	59	SA7636201	G - 25	18	SA9771001	M - 7	32
	Sp3	51	S35777101	Ga8	59	SA7849001	H - 38	20	SA9779001	M - 19	32
	Ga1	52	S36119021	V - 42	48	SA8061001	B - 12	4	SA9826001	A - 15	2
	Ga2	53	S36121021	V - 43	48	SA8085001	M - 18	32		Wa1	60
S02743001	Sp1	49	S37037002	V - 19	48	SA8100101	C - 12	8	SA9827001	K - 59	28
	Ga3	54	S37060001	A - 14	2	SA8102001	Sp3	51	SA9854001	H - 35	20
S02744001	Ga4	55		N1 - 36	34		Ga1	52	SA9893001	V - 33	48
S02748001	Ga4	55		Wa1	60		Ga2	53	SA9896001	N2 - 5	38
	Ga8	59	S38760001	Ga8	59		Ga4	55	SA9901101	N2 - 4	38
S02778022	V - 18	48	S39051001	C - 17	8		Ga5	56	SA9914001	N2 - 6	38
S02786002	V - 21	48	S40765001	V - 38	48		Ga6	57		Wa1	60
S02787002	V - 22	48	S41205001	M - 8	32	SA8103001	Sp3	51	SA9923101	N2 - 3	38
S02999201	Ga4	55	S41207000	M - 11	32		Ga7	58	SA9957001	A - 16	2
S03000201	Ga4	55	S51282101	V - 14	48	SA8104001	Ga3	54		Wa1	60
S03245001	F - 18	16	S51283001	V - 12	48	SA8105001	Ga1	52	SA9957002	A - 17	2
S03246001	F - 22	16	S52162000	N1 - 49	36		Ga2	53		N1 - 39	34
S03882201	Ga4	55	S52163000	N1 - 50	36		Ga3	54		Wa1	60
S04630000	B - 24+	4	S52164000	N1 - 45	34		Ga4	55	SB0705101	C - 40	8
S04632101	H - 15+	20	S52764001	G - 27	18		Ga5	56	SB1270001	V - 8	48
S07649001	Ga1	52	SA1120001	B - 5	4		Ga6	57		Wa2	61
	Ga2	53	SA1138101	B - 26+	4	SA8106001	Ga1	52	SB1271001	V - 9	48
S11222001	Ga2	53	SA1139101	B - 26+	4		Ga2	53		Wa2	61
S12441001	H - 20	20	SA1166001	B - 51	6		Ga4	55	SB1603001	E - 2	14
S13385001	C - 13	8	SA1173101	C - 1+	8		Ga5	56	SB1604001	E - 3	14
S13561101	C - 8+	8	SA1179001	C - 37	8		Ga6	57	SB1605001	E - 4	14
S13684001	Ga4	55		C - 42	8	SA8107001	Ga1	52	SB1607001	E - 6	14
	Ga5	56		N1 - 16	34		Ga2	53	SB1608001	E - 7	14
	Ga6	57	SA1229101	H - 25	20		Ga4	55	SB1609001	E - 8	14
S23651001	B - 2	4	SA1242001	D - 6	12		Ga5	56	SB1610001	E - 9	14
	B - 6	4		D - 17	12		Ga6	57	SB1611001	E - 10	14
	B - 32	4	SA1286001	F - 12	16	SA8108001	Ga1	52	SB1677001	F - 17+	16
	B - 36	4	SA1303101	G - 17	18		Ga2	53	SB3440001	A - 1	2
	B - 45	6		G - 31	18		Ga4	55	SB3480001	E - 5	14
	B - 47	6	SA1345001	H - 30	20		Ga5	56	SB3540001	J - 5	24
	B - 52	6	SA1360101	J - 21	24		Ga6	57	SB3544001	J - 9	24
	D - 14	12	SA1388101	L - 6	30	SA8109001	Ga1	52	SB3545101	J - 11	24
	D - 30	12	SA2161001	B - 16	4		Ga2	53	SB3548001	J - 12	24
	F - 8	16	SA2252101	B - 50	6		Ga4	55	SB3551001	J - 15	24
	F - 13	16	SA2345101	Sp2	50		Ga5	56	SB3552001	J - 17	24

CODE	REF.NO	Page	CODE	REF.NO	Page	CODE	REF.NO	Page	CODE	REF.NO	Page
SB3553001	J - 18	24	SB4903001	F - 1	16	SB5024001	P - 6	40	SB5314101	D - 15	12
SB3586001	N1 - 14	34	SB4904001	F - 10	16	SB5025001	P - 4	40	SB5315101	D - 4	12
SB3587001	N1 - 10	34	SB4911001	G - 3	18		P - 9	40	SB5316101	B - 42	6
SB3595101	H - 29	20	SB4915001	G - 29	18	SB5028001	M - 28	32	SB5317001	B - 55	6
SB3621001	Q - 4	42	SB4916001	G - 40	18		P - 7	40	SB5318001	B - 31	4
SB3627001	V - 4	48	SB4918001	G - 36	18	SB5030001	C - 32	8	SB5627001	H - 27	20
SB3628001	V - 5	48	SB4922101	H - 23	20		C - 39	8	SB5628001	B - 53	6
SB3655001	T - 5	44	SB4923001	H - 24	20	SB5031001	C - 43	8	SB5629001	B - 54	6
SB3665001	N1 - 26	34	SB4924001	H - 26	20	SB5032001	B - 25	4	SB5630101	H - 37	20
SB3776001	B - 14	4	SB4928001	H - 12	20	SB5034001	N1 - 9	34	SB5631101	K - 27	26
SB3816101	N1 - 2+	34	SB4929001	H - 13	20	SB5035201	N1 - 34	34	SB5633001	V - 3	48
SB3817401	N1 - 2+	34	SB4932001	H - 39	20	SB5036001	G - 9	18	SB5634001	V - 27	48
SB3837001	N1 - 28	34	SB4933001	H - 2	20	SB5037001	B - 49	6	SB5638001	A - 8	2
SB3850001	A - 12	2	SB4934001	H - 32	20	SB5039001	B - 58	6	SB5639101	G - 11	18
SB3854001	E - 1	14	SB4936001	J - 6	24	SB5041001	F - 15+	16	SB5645101	Q - 1+	42
SB3872001	N1 - 32	34	SB4940001	J - 7	24	SB5042001	F - 15+	16	SB5646101	Q - 2	42
SB3928001	V - 11	48	SB4941001	K - 4	26	SB5043001	A - 7	2	SB5648001	Sp1	49
SB4096001	U - 3	46	SB4942101	K - 11	26	SB5044001	A - 9	2		Ga3	54
SB4114001	V - 13	48	SB4943001	K - 5	26	SB5045001	T - 3	44	SB5650001	K - 58	28
SB4117001	V - 16	48	SB4944001	K - 21	26	SB5046001	V - 6	48	SB5652101	J - 1	24
SB4118001	V - 20	48	SB4948101	K - 9	26	SB5047001	V - 28	48	SB5663401	P - 1+	40
	V - 26	48	SB4949101	K - 8	26	SB5048001	V - 29	48	SB5673001	K - 62	28
SB4119001	V - 17	48	SB4950201	K - 7	26	SB5049001	C - 2	8	SB5674001	C - 46	10
SB4120001	V - 25	48	SB4951201	K - 15	26	SB5225001	Sp2	50	SB5675001	G - 35	18
SB4155001	M - 6	32	SB4952101	K - 13	26		Sp3	51	SB5987001	T - 1+	44
	N1 - 33	34	SB4953001	K - 65	28		Ga7	58	SB6237101	P - 1+	40
SB4243001	V - 34	48	SB4954101	K - 1	26	SB5226001	Ga7	58	SB6353001	T - 2+	44
SB4531001	N2 - 7	38	SB4955001	K - 32	26	SB5227001	B - 33	4	SB6391001	N1 - 42	34
SB4587301	N1 - 2+	34	SB4956101	K - 33	26	SB5229001	C - 24	8	SB6402001	N1 - 40	34
SB4803001	N1 - 51	36	SB4957001	K - 20	26	SB5237101	M - 2	32	SB6427001	A - 18	2
SB4845001	A - 2	2	SB4960001	K - 38	26	SB5238001	M - 10	32		A - 19	2
SB4846101	M - 1	32	SB4961001	K - 41	26	SB5239001	M - 13	32	SB6430001	D - 33	12
SB4848001	B - 44	6	SB4962001	K - 40	26	SB5242001	M - 22	32	SB6453001	N1 - 1+	34
SB4849001	B - 35	4	SB4963001	K - 53	28	SB5244001	Ga7	58	SB6454001	N1 - 1+	34
SB4857001	B - 56	6	SB4964001	K - 45	26	SB5248001	B - 9+	4	SB6455001	N1 - 1+	34
SB4858001	B - 57	6	SB4965001	K - 54	28	SB5252001	B - 9+	4	SB6456001	N1 - 1+	34
SB4864001	C - 18	8	SB4966001	K - 64	28	SB5253001	B - 9+	4	SB6457001	N1 - 3+	34
SB4865001	C - 20	8	SB4967101	K - 56	28	SB5257001	K - 46	26	SB6458001	N1 - 3+	34
SB4866001	C - 30	8	SB4968001	K - 34	26	SB5258001	M - 3	32	SB6564001	C - 45	10
SB4867101	C - 22	8	SB4969001	K - 14	26	SB5262001	C - 10	8	SB6568001	F - 17+	16
SB4868001	C - 33	8	SB4970001	L - 1	30	SB5265101	H - 1	20			
SB4869001	C - 36	8	SB4971001	L - 2	30	SB5267101	Q - 1+	42			
SB4870001	C - 26	8	SB4972001	L - 4	30	SB5269001	F - 2	16			
	C - 28	8	SB4973101	N1 - 4	34	SB5270001	F - 4	16			
SB4871001	C - 38	8	SB4974101	N1 - 31	34	SB5272001	F - 7	16			
SB4872001	C - 31	8	SB4975001	N1 - 24	34	SB5275101	F - 14	16			
SB4873101	C - 23	8	SB4976001	N1 - 5	34	SB5276101	G - 1	18			
SB4874101	C - 41	8	SB4977101	N1 - 19	34	SB5280001	G - 19	18			
SB4879001	D - 3	12	SB4978001	N1 - 8	34	SB5281001	G - 2	18			
SB4882001	D - 24	12	SB4979001	N1 - 12	34	SB5284201	G - 21	18			
SB4883001	D - 25	12	SB4980001	N1 - 13	34	SB5286201	G - 30	18			
SB4884001	D - 26	12	SB4981101	N1 - 15	34	SB5287001	G - 7	18			
SB4885101	D - 9	12	SB4982101	N1 - 17	34	SB5288101	H - 14+	20			
SB4887001	D - 19	12	SB5002001	G - 5	18	SB5289101	H - 14+	20			
SB4888101	D - 10	12	SB5004001	G - 38	18	SB5290001	B - 1	4			
SB4889001	D - 21	12	SB5005201	U - 1	46	SB5291101	B - 46	6			
SB4892201	D - 36	12	SB5008001	J - 23	24	SB5294201	D - 8+	12			
SB4893101	D - 23	12	SB5009001	J - 3	24	SB5297201	D - 8+	12			
	D - 32	12	SB5010001	J - 4	24	SB5300201	D - 28	12			
SB4894001	D - 7	12	SB5011001	J - 28	24	SB5301001	K - 35	26			
	D - 18	12	SB5012001	J - 29	24	SB5306001	M - 26	32			
SB4900001	D - 2	12	SB5013001	J - 25	24	SB5310101	K - 44	26			
SB4901001	D - 13	12	SB5014001	J - 14	24	SB5312001	A - 10	2			

brother

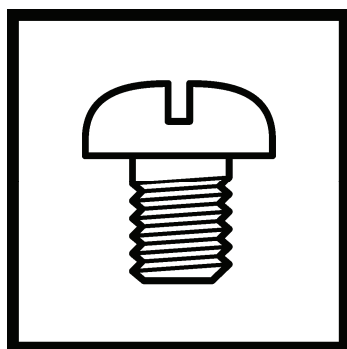

パーツブック
PARTS BOOK

ブラザー工業株式会社 <http://www.brother.co.jp/>
〒448-0803 刈谷市野田町北地藏山1番地5 TEL:0566-95-0085

BROTHER INDUSTRIES, LTD. <http://www.brother.com/>
1-5, Kitajizoyama, Noda-cho, Kariya 448-0803, Japan. Phone : 81-566-95-0088