

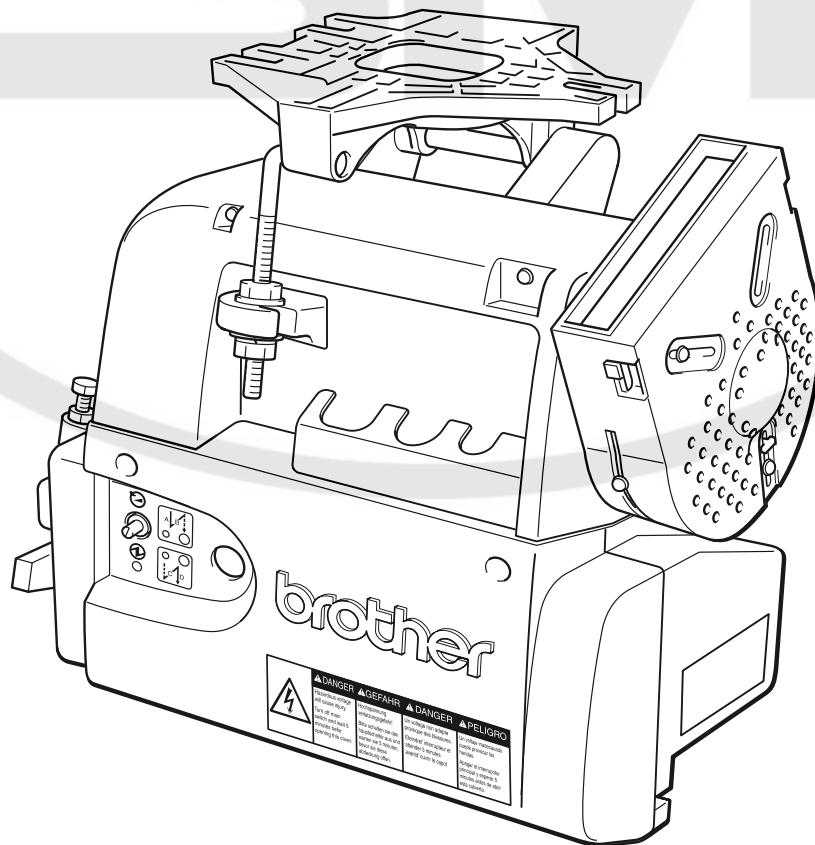

AC SERVOMOTOR
AC-SERVOMOTOR
SERVOMOTEUR AC
SERVOMOTOR DE AC

MD-6020 (Single-Phase Type)
MD-6120 (Three-Phase Type)

PARTS BOOK
TEILEKATALOG
LIVRE DES PIECES
LIBRO DE REFERENCIA DE PIEZAS

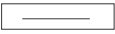

Notes for using this parts book

1. If the symbol  is found in the “Parts No.” column of the “Assembly No.” column, refer to the different parts list on page 16.
2. The symbol  in the “Parts No.” column indicates that the parts is not available for supply. If, however, there is a number in the “Assembly No.” column, the parts can be ordered as an assembly. Please, therefore, order by using the assembly number.
3. This book was prepared based on information available in July 2001.
4. Parts are subject to changes in design without prior notice.

Hinweise zur Verwendung dieser Teileliste

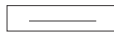
1. Dieses Zeichen  in der Spalte “Parts No. (Teilnummer)” oder “Assembly No. (Gerätesatznummer)” verweist auf die Gesonderte Stückliste auf Seite 16.
2. Dieses Zeichen  in der Spalte “Teilnummer” bedeutet, daß dieser Teil nicht lieferbar ist. Wenn jedoch in der Spalte “Gerätesatznummer” eine Nummer steht, kann dieser Teil als ein Geräteteilsatz bestellt werden. Bestellen Sie daher bitte mit dieser Gerätesatznummer.
3. Dieses Buch basiert auf den Informationen vom Juli 2001.
4. Modelländerungen sind vorbehalten.

CONTENTS

A. Motor (1)	1
B. Motor (2)	3
C. Control box	5
D. Operation panel	7
E. Switch box	9
F. Material edge sensor related (option) (1)	11
G. Material edge sensor related (option) (2)	12
H. Pedal for standing operation	13
J. Synchronizer	15
DIFFERENT PARTS LIST	16
INDEX	17

INHALTSVERZEICHNIS

A. Motor (1)	1
B. Motor (2)	3
C. Schaltkasten	5
D. Bedienungstafel	7
E. Schaltkasten	9
F. Für Materialkantensensor (Sonderausstattung) (1)	11
G. Für Materialkantensensor (Sonderausstattung) (2)	12
H. Fusstritt für stehenden Arbeitsplatz	13
J. Synchronisator	15
ZUBEHÖRLISTE	16
VERZEICHNIS	17

Notes sur l'utilisation de ce manuel de pièces détachées

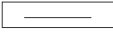
1. Si le symbole  se trouve dans la colonne "Parts No. (N° de pièce)" ou dans la colonne "Assembly No. (N° jeu de pièces)", veuillez vous référer à la liste de pièces annexe page 16.
2. Le symbole  dans la colonne "N° de pièce" signifie que la pièce ne peut être fournie. Si, dans la colonne "N° jeu de pièces", il y a un numéro de nomenclature, la pièce peut être commandée comme faisant partie d'un jeu de pièces. Donc, pour toute commande, veuillez spécifier le n° du jeu de pièces.
3. Ce manuel a été fait d'après les renseignements valables au mois de Juillet 2001.
4. Les pièces peuvent être sujettes à des modifications sans préavis.

Notas para usar este Libro de Piezas

1. De haber un símbolo  junto al "Parts No. (Número de Pieza)" o en la columna del "Assembly No. (Número de juego)", habrá que mirar la lista de piezas separada de la página 16.
2. El símbolo , que se encuentra en la columna del "Número de Pieza", quiere decir que no se dispone de dicha pieza sola. Cuando, empero, hay un número en la columna del "Número de Juego", se podrá ordenar la pieza con todo el juego. Por lo tanto, será mejor hacer el pedido recurriendo al número del juego respectivo.
3. Este libro ha sido compilado basándose en los datos de que se disponía en julio 2001.
4. Las piezas quedan sujetas a cambios de diseño sin aviso previo.

TABLE DES MATIERES

A. Moteur (1).....	1
B. Moteur (2).....	3
C. Boîtier de commande.....	5
D. Panneau de commande.....	7
E. Boîtier d'interrupteurs.....	9
F. Capteur de bord de tissu relatif (en option) (1).....	11
G. Capteur de bord de tissu relatif (en option) (2).....	12
H. Pédale pour opération en station debou.....	13
J. Synchroniseur.....	15
LISTE DES PIECES ACCESSOIRES.....	16
INDEX.....	17

INDICA

A. Motor (1).....	1
B. Motor (2).....	3
C. Caja de controles.....	5
D. Panel de control.....	7
E. Caja de interruptores.....	9
F. Piezas relacionadas al detector de borde de tejidos (opcional) (1).....	11
G. Piezas relacionadas al detector de borde de tejidos (opcional) (2).....	12
H. Pedal para operar de pie.....	13
J. Sincronizador.....	15
LISTA DE PIEZAS ACCESORIAS.....	16
INDICE.....	17

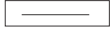
A. Motor (1) / Motor (1) / Moteur (1) / Motor (1)

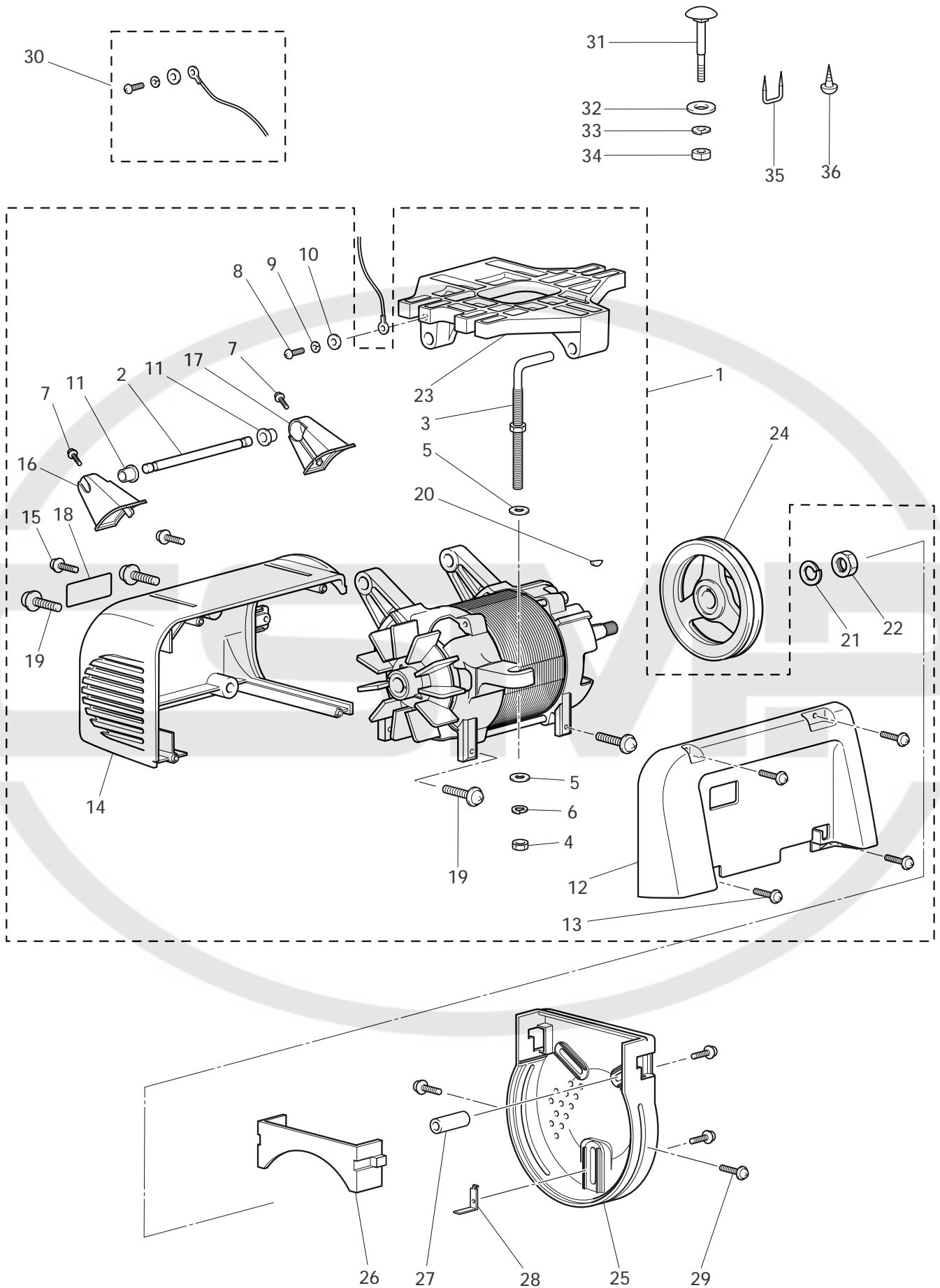

REF. NO.	CODE	Q'TY	NAME OF PARTS	REF. NO.	CODE	Q'TY	NAME OF PARTS
1	J80901-001	1	MOTOR ASSY	19	0A4502-005	4	SCREW 5X20DA
2	J03758-001	1	PIN 8X121	20	216205-000	1	KEY 4X13#2
3	J03759-001	1	L BOLT ASSY	21	028100-246	1	SPRING WASHER 2-10
4	021100-206	1	NUT 2-10	22	J02493-001	1	NUT 3-M10X1.0
5	025100-236	2	PLAIN WASHER 10	23	J03757-001	1	MOTOR MOUNTING BASE
6	028100-246	1	SPRING WASHER 2-10	24	*	1	TAPER PULLEY
7	215082-003	2	SCREW 4X12DA	25	J03763-001	1	BELT COVER
8	062401-063	1	SCREW 4X10	26	J03764-001	1	BELT SUB COVER
9	028040-245	1	SPRING WASHER 2-4	27	J02293-001	1	FINGER GUARD
10	025040-173	1	PLAIN WASHER 4	28	J00351-001	1	BELT CLAMP PLATE 2
11	J03824-001	2	RUBBER CUSHON	29	229017-001	4	SCREW 4X10DA
12	J03747-001	1	FRONT MOTOR COVER	30	J02832-001	1	EARTH CORD ASSY
13	085311-016	4	TAPTITE,BIND B 3X10	31	234618-001	3	BOLT 8X65
14	J03748-001	1	REAR MOTOR COVER	32	025080-336	3	WASHER,PLAIN L8
15	229017-001	2	SCREW 4X10DA	33	028080-246	3	WASHER,SPRING 2-8
16	J03802-001	1	BH COVER PLAY	34	021080-206	3	NUT 2-8
17	J03803-001	1	BH COVER LOAD	35	200190-001	5	STAPLE
18	---	1	MOTOR NAME PLATE	36	S03816-001	2	WOOD SCREW 4.5X16

DIFFERENT PARTS LIST

REF. NO.	MACHINE HEAD (SINGLE NEEDLE)	TAPER PULLEY	REF. NO.	MACHINE HEAD (TWIN NEEDLE)	TAPER PULLEY
24	737	J02281-001 105	24	842	J02278-001 90
	201				
	722				
	724				
	748				
	791				
	798 /728				
	852 /853 /854				
	883				
	Over locker				
	774				
	772				
	778				
				847	
				848	
				837	
				878	

B. Motor (2) / Motor (2) / Moteur (2) / Motor (2)

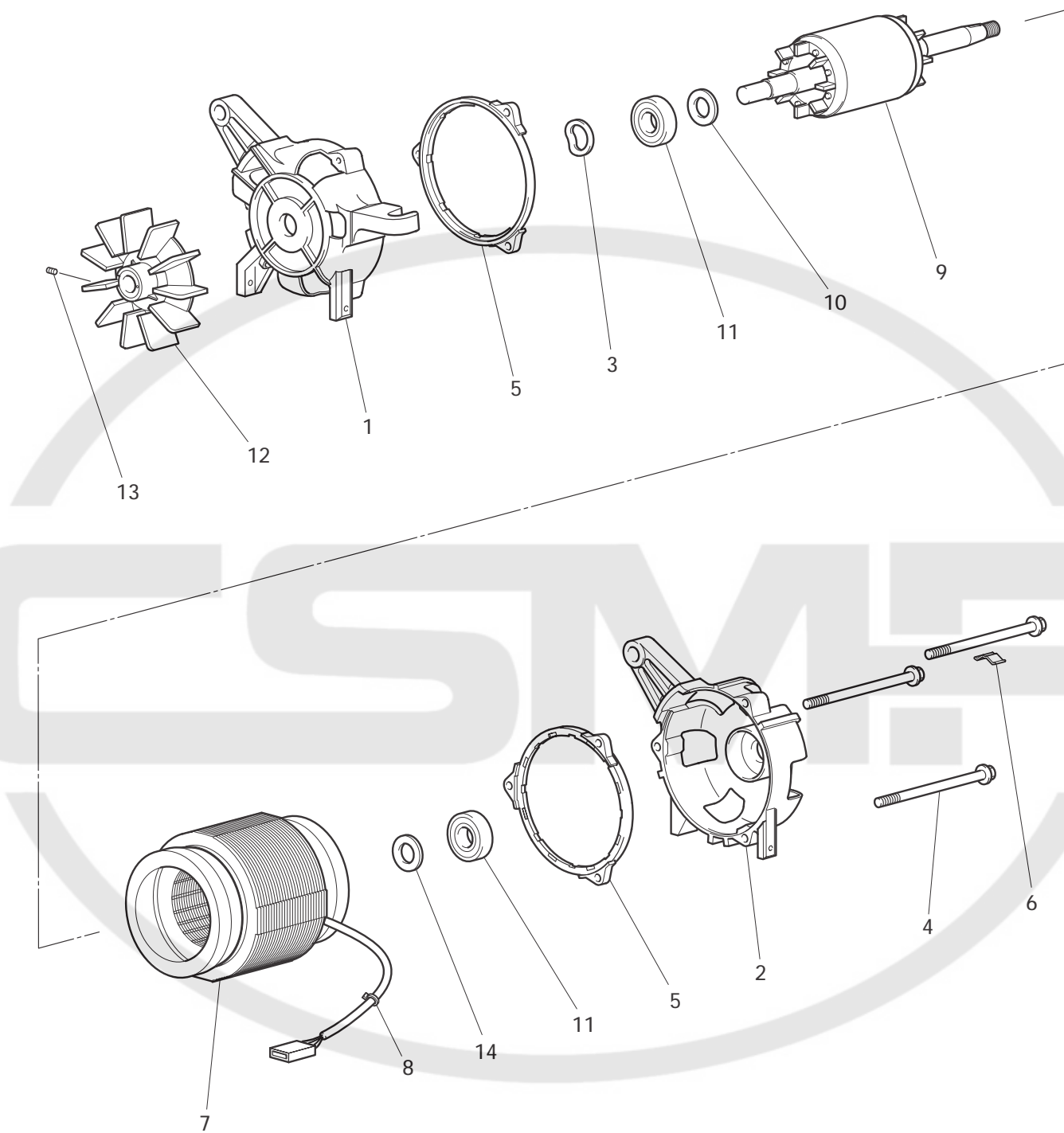

REF. NO.	CODE	Q'TY	NAME OF PARTS
1	*	1	MOTOR BRACKET PLAY
2	*	1	MOTOR BRACKET LOAD
3	203684-001	1	WAVE WASHER 0.3X27.5X34.9
4	J03829-001	3	SCREW 5X120DB
5	*	2	INSULATION RING
6	*	1	EARTH SPRING PLATE
7	J80902-001	1	STATOR ASSY
8	J01463-001	1	BINDER 3.5X150
9	J03892-001	1	ROTOR ASSY ,ANA
10	224485-000	1	WASHER 2X15X22ST
11	076202-801	2	BEARING 6202ZZ
12	J02525-001	1	MOTOR FAN
13	014500-632	1	SET SCREW 5X6
14	J02997-001	1	WASHER 2.6X15X26ST

DIFFERENT PARTS LIST

REF. NO.	NAME OF PARTS	NAME PLATE "MD-60A"	NAME PLATE "M-60C"
1	MOTOR BRACKET PLAY	J03755-001	J03866-001
2	MOTOR BRACKET LOAD	J03756-001	J03867-001
5	INSULATION RING	J03760-001	none
6	EARTH SPRING PLATE	J03762-001	none

Example:Motor name plate "M-60C"

brother M-60C AC SERVO MOTOR NO. D029A1101	OUT PUT 400W R.P.M. 3500
	SUPPLIED FROM CONTROL BOX MD-6020/6120 BROTHER INDUSTRIES, LTD MADE IN JAPAN

C. Control box / Schaltkasten
 Boîtier de commande / Caja de controles

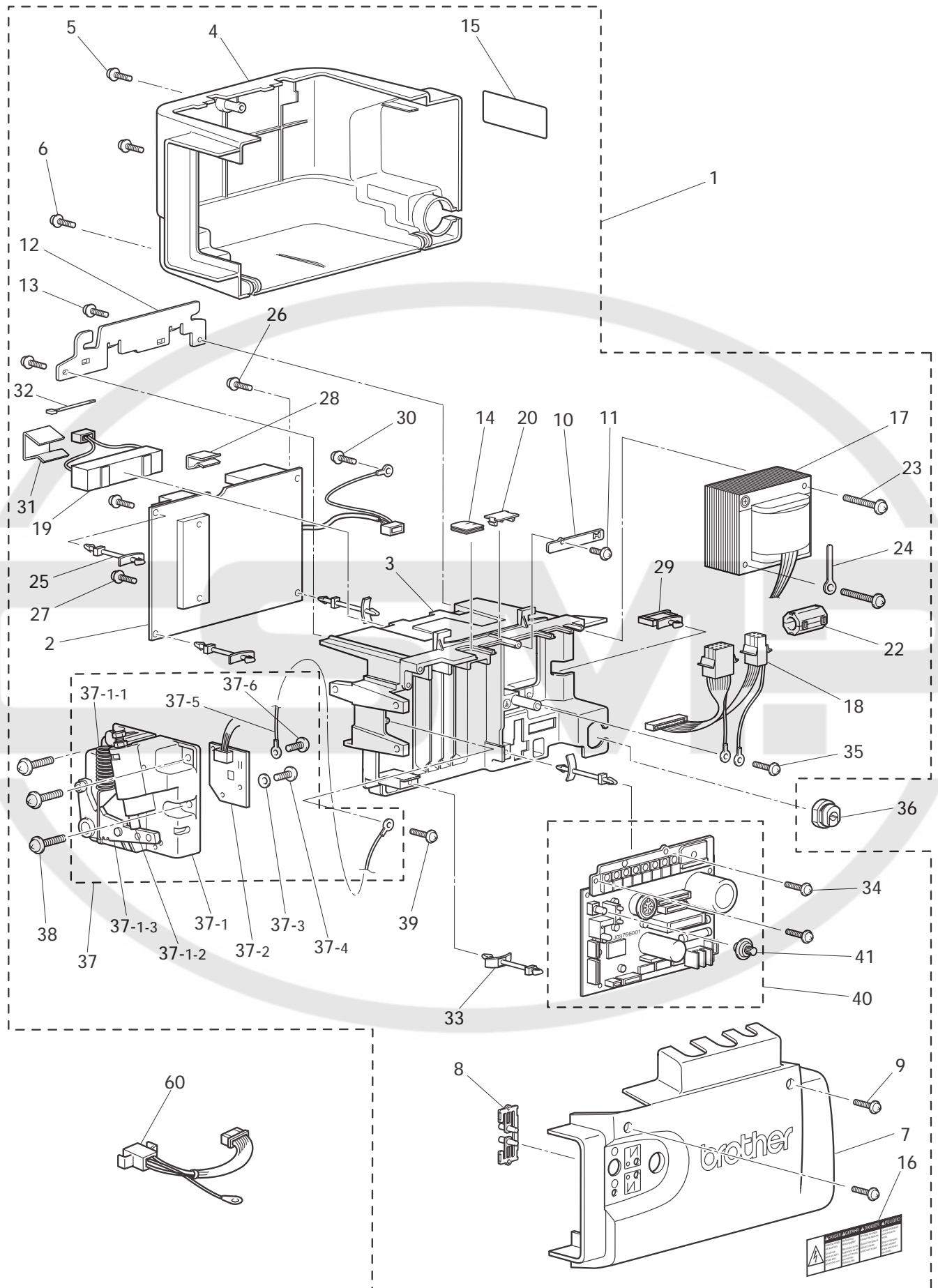

REF. NO.	CODE	Q'TY	NAME OF PARTS	REF. NO.	CODE	Q'TY	NAME OF PARTS
1	*	1	CONTROL BOX ASSY ,602	29	J01354-001	1	WIRE SADDLE ,LWS-3S
2	*	1	POWER PCB ASSY ,602	30	229017-001	1	SCREW 4X10DA
3	J03736-001	1	BASE FRAME ,LCA	31	J03739-001	1	SPRING PLATE ,CR
4	J03740-001	1	REAR BOX COVER	32	220681-001	1	CABLE TIE ,2.2X85
5	J02568-001	1	SCREW 4X25DA	33	J03744-001	2	HOLDER KGLS-10S
6	229017-001	2	SCREW 4X10DA	34	229017-001	2	SCREW 4X10DA
7	J03741-001	1	FRONT BOX COVER	35	229017-001	1	SCREW 4X10DA
8	J03742-001	1	KEY TOP ,LCA	36	J02195-001	1	BUSHING ,SR-7K-2
9	J02568-001	2	SCREW 4X25DA	37	*	1	TREADLE UNIT
10	J03801-001	1	CONNECTOR PRESSER PLATE	37-1	*	1	TREADLE BASE ASSY
11	0A4300-805	1	SCREW 3X8DA	37-1-1	J00649-001	1	TREADLE SPRING ,12.6X86
12	J03737-001	1	FIXED PLATE ,LCA	37-1-2	J03858-001	1	PRESSER BAR ASSY
13	229017-001	2	SCREW 4X10DA	37-1-3	J03637-001	1	TREADLE LEVER ,E3
14	J03743-001	1	RUBBER COAD BUSH	37-2	J80875-001	1	TREADLE PCB ASSY ,P8
15	---	1	BOX NAME PLATE	37-3	J02130-001	3	SPRING WASHER 0.3X4.3X8
16	S38352-101	1	WARNING LABEL	37-4	037401-015	3	TAPPING SCREW ,V 4X10
17	*	1	TRANSFORMER	37-5	J03827-001	1	EARTH CORD ASSY ,LCA
18	J03778-001	1	MACHINE PLUG ASSY ,602	37-6	229017-001	1	SCREW 4X10DA
19	J03745-001	1	FIXED RESISTOR ASSY ,602	38	J00353-001	3	SCREW 5X14DB
20	J02039-001	1	FOOT PLUG CAP	39	229017-001	1	SCREW 4X10DA
22	UK3745-000	1	CORE ,ESD-SR-12	40	J80900-001	1	CONTROL PCB ASSY ,602
23	J01411-001	2	SCREW 4X50DA	41	J03733-001	1	SPEED ADJUST KNOB
24	414959-001	1	SHIELDED WIRE CLIP				
25	J03744-001	3	HOLDER ,KGLS-10S				
26	229017-001	1	SCREW 4X10DA				
27	0A4401-605	2	SCREW 4X16DA				
28	J03738-001	1	SPRING PLATE ,BD				
				60	<Option Parts For Standing operation> J02824-001	1	FOOT PLUG ASSY

DIFFERENT PARTS LIST

REF. NO.	POWER SUPPLY	CONTROL BOX ASSY ,602
1	1 -110V	J80905-001
	1 -220V	J80906-001
	1 -230V	J80907-001
	1 -240V	
	1 -230V CE	J80908-001
	1 -240V CE	
	3 -220V	J80909-001

DIFFERENT PARTS LIST

REF. NO.	POWER SUPPLY	POWER PCB ASSY ,602
2	1 -110V	J80898-001
	1 -220V	J80895-001
	1 -230V	
	1 -240V	
	1 -230V CE	J80896-001
	1 -240V CE	
	3 -220V	J80897-001

DIFFERENT PARTS LIST

REF. NO.	POWER SUPPLY	TRANSFORMER
17	1 -110V	J03711-001
	1 -220V	J03710-001
	1 -230V	
	1 -240V	
	3 -220V	

1 ; SINGLE PHASE
3 ; THREE PHASE

DIFFERENT PARTS LIST

REF. NO.	DESTINATION	TREADLE UNIT	TREADLE BASE ASSY	TREADLE TYPE
37 37-1	Korea Southeast Asia Hong Kong	J80903-001	J03634-002	With one forward and one back step
	Australia USA , Canada Europe Brazil etc	J80904-001	J03674-002	With two forward and two back steps

Control box assy and control pcb assy are set to general specifications (product code MD6*20-13012**B0) for shipment from the factory. <For 737 , 4700rpm ,Treadle with one forward and one back step> Therefore, you must set the control pcb **DIP switches** referring to the Instruction manual of MD-6020/6120 , if you change the machine head and sewing speeds.

D. Operation panel / Bedienungstafel
 Panneau de commande / Panel de control

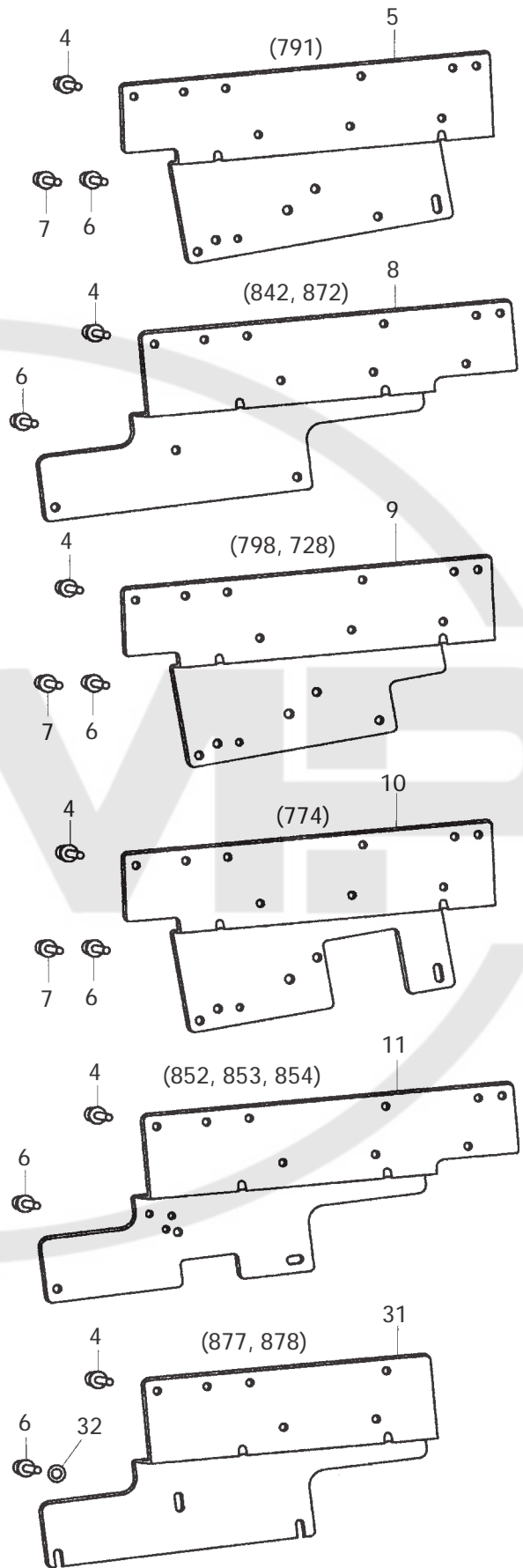
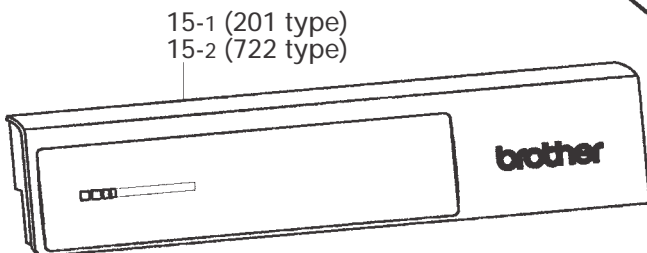
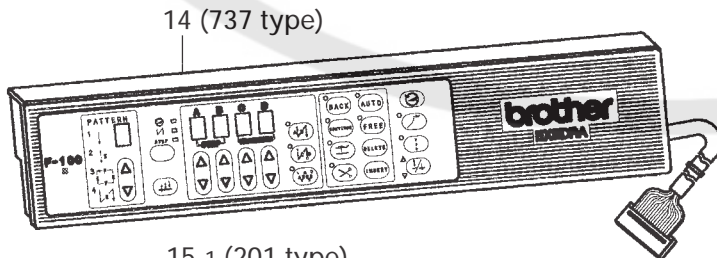
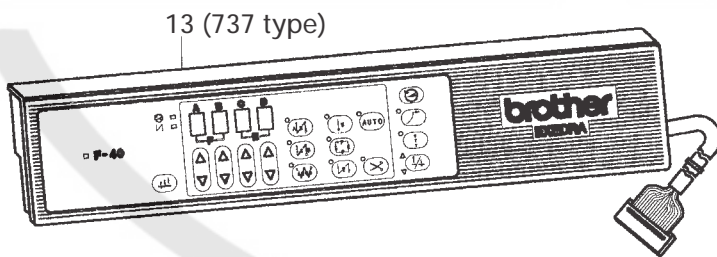
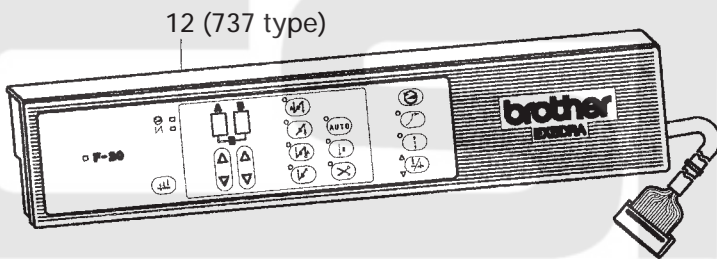
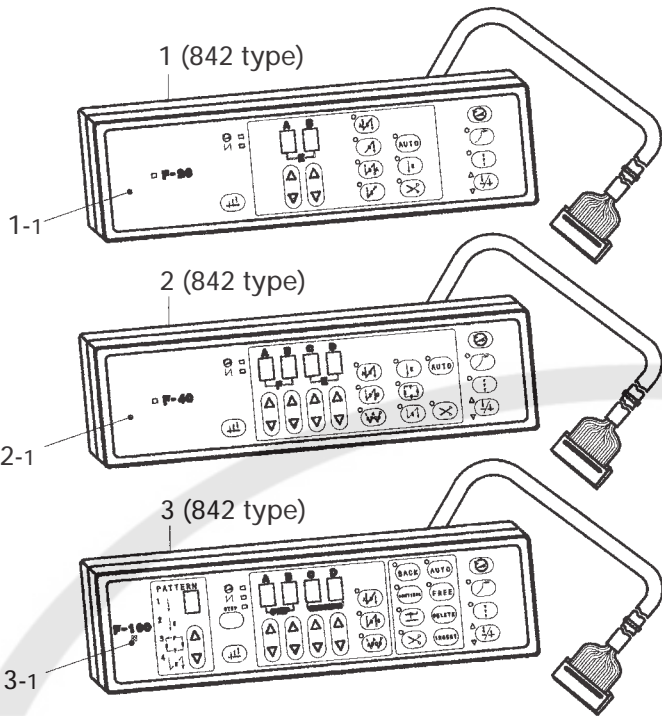

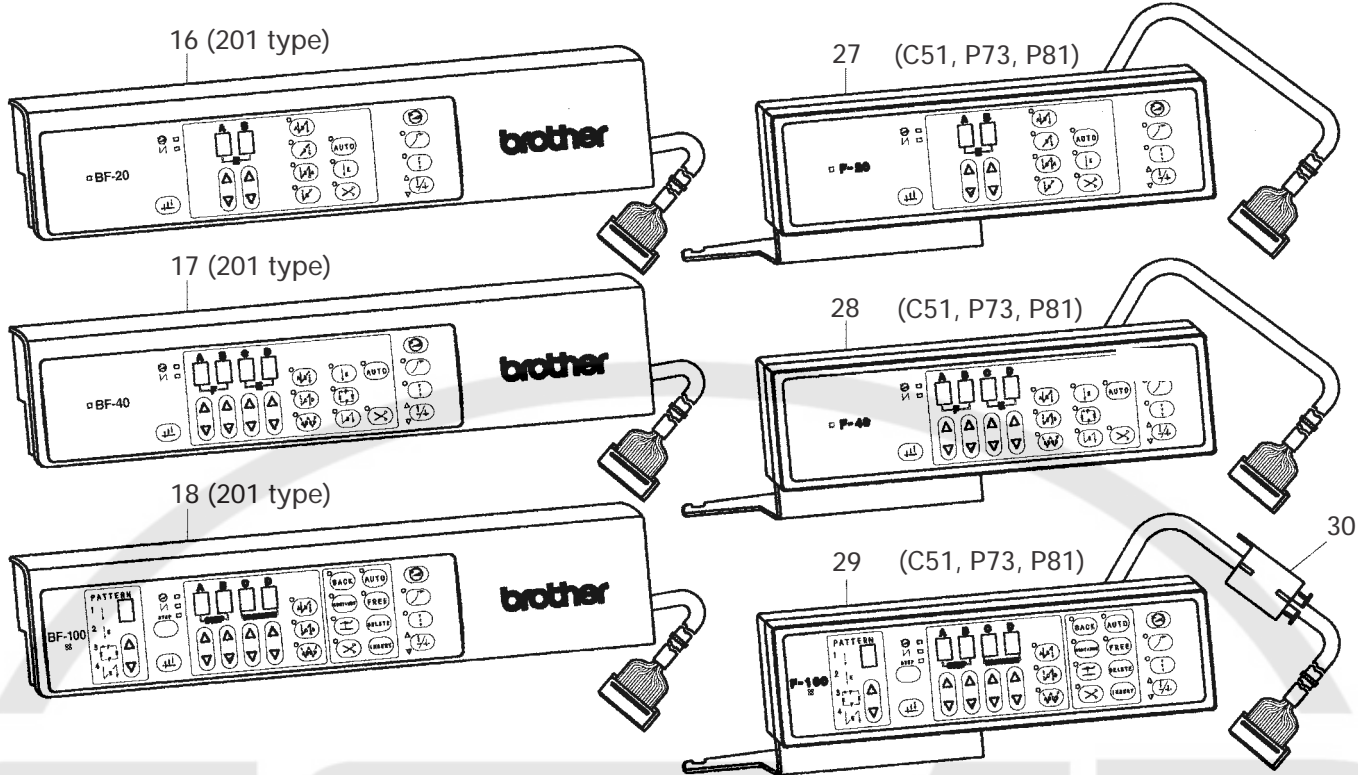

REF. NO.	CODE	Q'TY	NAME OF PARTS
1	BMP2070821F1000	1	F-20 OPERATION PANEL
1-1	J01990-001	1	F-20 PANEL PLATE
2	BMP2070822F1000	1	F-40 OPERATION PANEL
2-1	J01989-001	1	F-40 PANEL PLATE
3	BMP2070823F1000	1	F-100 OPERATION PANEL
3-1	J01988-001	1	F-100 PANEL PLATE
4	215081-002	3	SCREW 4X10DB
5	J02058-001	1	HB-SETTING PLATE#F1
6	062681-212	3	SCREW 4.37-40X12
7	062671-212	3	SCREW 3.57-40X12
8	J02059-001	1	HB-SETTING PLATE#F3
9	J02054-001	1	HB-SETTING PLATE#F1-2
10	J02566-001	1	HB-SETTING PLATE#F2
11	J02567-001	1	HB-SETTING PLATE#F5
12	BMP2070121F1000	1	F-20 OPERATION PANEL
13	BMP2070122F1000	1	F-40 OPERATION PANEL
14	BMP2070123F1000	1	F-100 OPERATION PANEL
15-1	J80633-001	1	BF-0 OPERATION PANEL
15-2	J80899-001	1	BF-0 OPERATION PANEL TR
16	BMP2070221F1000	1	BF-20 OPERATION PANEL
16-1	J03849-001	1	BF-20 PANEL PLATE
17	BMP2070222F1000	1	BF-40 OPERATION PANEL
17-1	J03850-001	1	BF-40 PANEL PLATE
18	BMP2070223F1000	1	BF-100 OPERATION PANEL
18-1	J03851-001	1	BF-100 PANEL PLATE

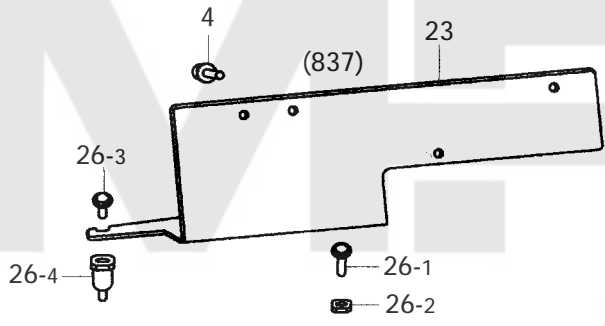

REF. NO.	CODE	Q'TY	NAME OF PARTS
23	J02061-001	1	HB-SETTING PLATE#F6
26-1	062401-605	1	SCREW 4X16
26-2	021400-205	1	NUT 2-4
26-3	224508-001	2	SCREW 4X10DC
26-4	---	2	STUD SM4.37X29
27	BMP2070D21F4000	1	F-20 OPERATION PANEL SE
28	BMP2070D22F4000	1	F-40 OPERATION PANEL SE
29	BMP2070D23F4000	1	F-100 OPERATION PANEL SE
30	J80631-001	1	EMC FERRITE CORE
31	J03555-001	1	HB-SETTING PLATE#F3-2
32	025680-232	3	PLAIN WASHER 4.37

E. Switch box / Schaltkasten
 Boîtier d'interrupteurs / Caja de interruptores

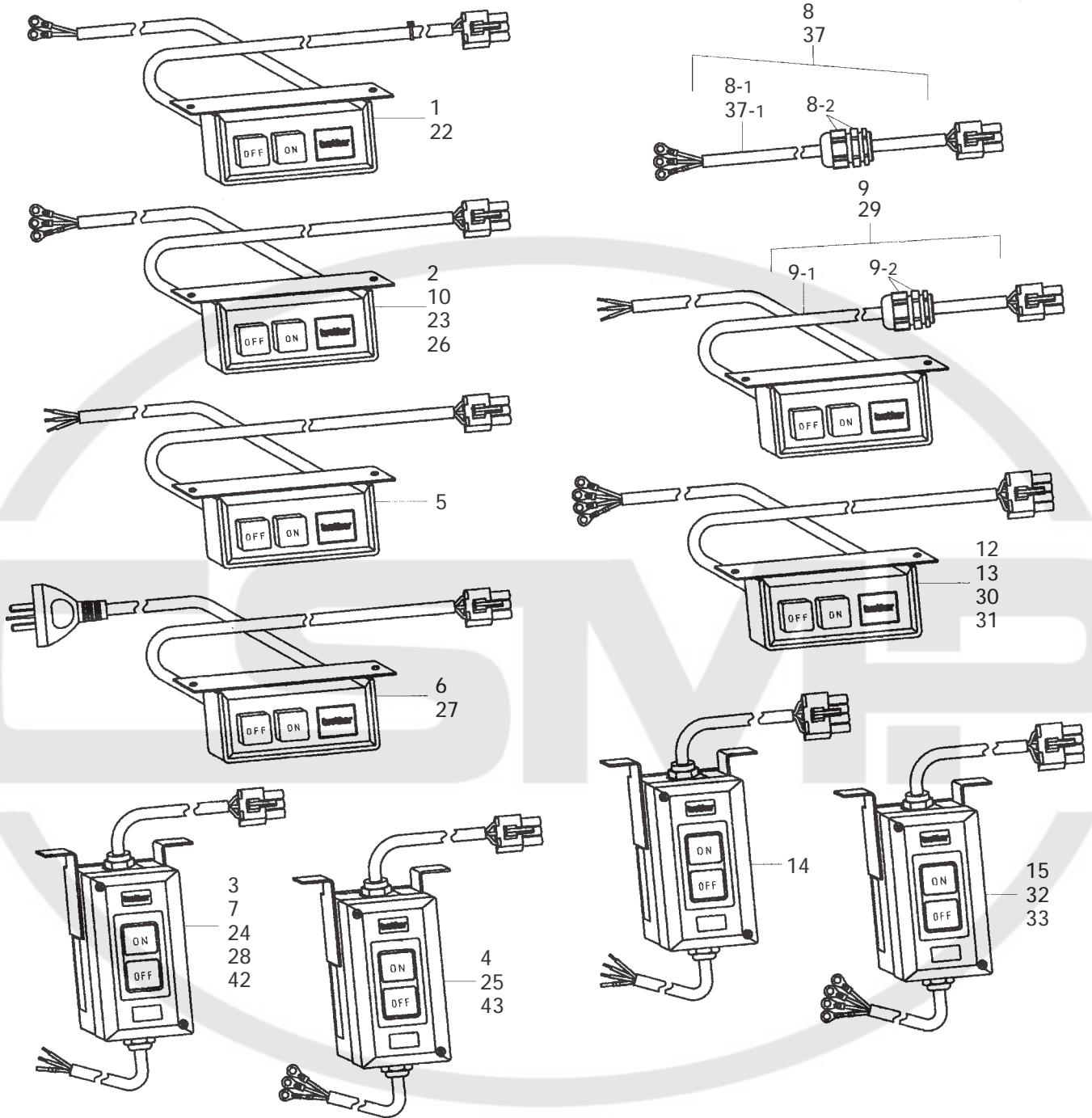

REF. NO.	CODE	Q'TY	NAME OF PARTS	MACHINE HEAD	POWER SUPPLY	TYPE	DESTINATION
1	229240-001	1	2P SWITCH ASSY#19-3		1 -110 V		
2	230542-001	1	2P SWITCH ASSY#19-4		1 -110 V	SJT	Canada
3	J02045-001	1	2P SWITCH ASSY#24		1 -110 V	OCR	USA
4	237272-001	1	2P SWITCH ASSY#16-3		1 -110 V	SJT OCR	Canada
5	J01244-001	1	2P SWITCH ASSY#31-2		1 -220 ~ 240 V		
6	236127-001	1	2P SWITCH ASSY#19-7		1 -240 V	SAA	Australia,New Zealand
7	J02046-001	1	2P SWITCH ASSY#25		1 -220 ~ 240 V	OCR	
8	J03134-001	1	3P PLUG ASSY#10K32		1 -230 V	CE	Europe
8-1	J02302-001	1	3P PLUG ASSY#10-32				
8-2	J03588-001	1	BUSHING JPG13.5				
9	J03238-001	1	2P SWITCH ASSY#31K2		1 -230 V		Greece
9-1	J01244-001	1	2P SWITCH ASSY#31-2				
9-2	J03588-001	1	BUSHING JPG13.5				
10	J03390-001	1	2P SWITCH ASSY#19-8		1 -220 V	SJT	Canada
12	229250-001	1	3P SWITCH ASSY#11-7		3 -220 ~ 240 V		
13	230545-001	1	3P SWITCH ASSY#11-8		3 -220 V	SJT	Canada
14	J02047-001	1	3P SWITCH ASSY#15		3 -220 V	OCR	USA
15	237273-001	1	3P SWITCH ASSY#9-16		3 -220 V	SJT OCR	Canada
22	J00452-001	1	2P SWITCH ASSY#19-23	883	1 -110 V		
23	J00455-001	1	2P SWITCH ASSY#19-24	883	1 -110 V	SJT	Canada
24	J00453-001	1	2P SWITCH ASSY#16-12	883	1 -110 V	OCR	USA
25	J00457-001	1	2P SWITCH ASSY#16-23	883	1 -110 V	SJT OCR	Canada
26	J00460-001	1	2P SWITCH ASSY#19-22	883	1 -220 ~ 240 V		
27	J00464-001	1	2P SWITCH ASSY#19-27	883	1 -240 V	SAA	Australia,New Zealand
28	J00462-001	1	2P SWITCH ASSY#22-11	883	1 -220 V	OCR	
29	J03247-001	1	2P SWITCH ASSY#31L2	883	1 -230 V		Greece
30	J00470-001	1	3P SWITCH ASSY#11-17	883	3 -220 ~ 240 V		
31	J00473-001	1	3P SWITCH ASSY#11-18	883	3 -220 V	SJT	Canada
32	J02432-001	1	3P SWITCH ASSY#15-21	883	3 -220 V	OCR	USA
33	J00477-001	1	3P SWITCH ASSY#9-26	883	3 -220 V	SJT OCR	Canada
37	J03313-001	1	3P PLUG ASSY#10K22	883	1 -230 V	CE	Europe
37-1	J00461-001	1	3P PLUG ASSY#10-22				

F. Material edge sensor related (option) (1) / Für Materialkantensensor (Sonderausstattung) (1)
 Capteur de bord de tissu relatif (en option) (1) /
 Piezas relacionadas al detector de borde de tejidos (opcional) (1)

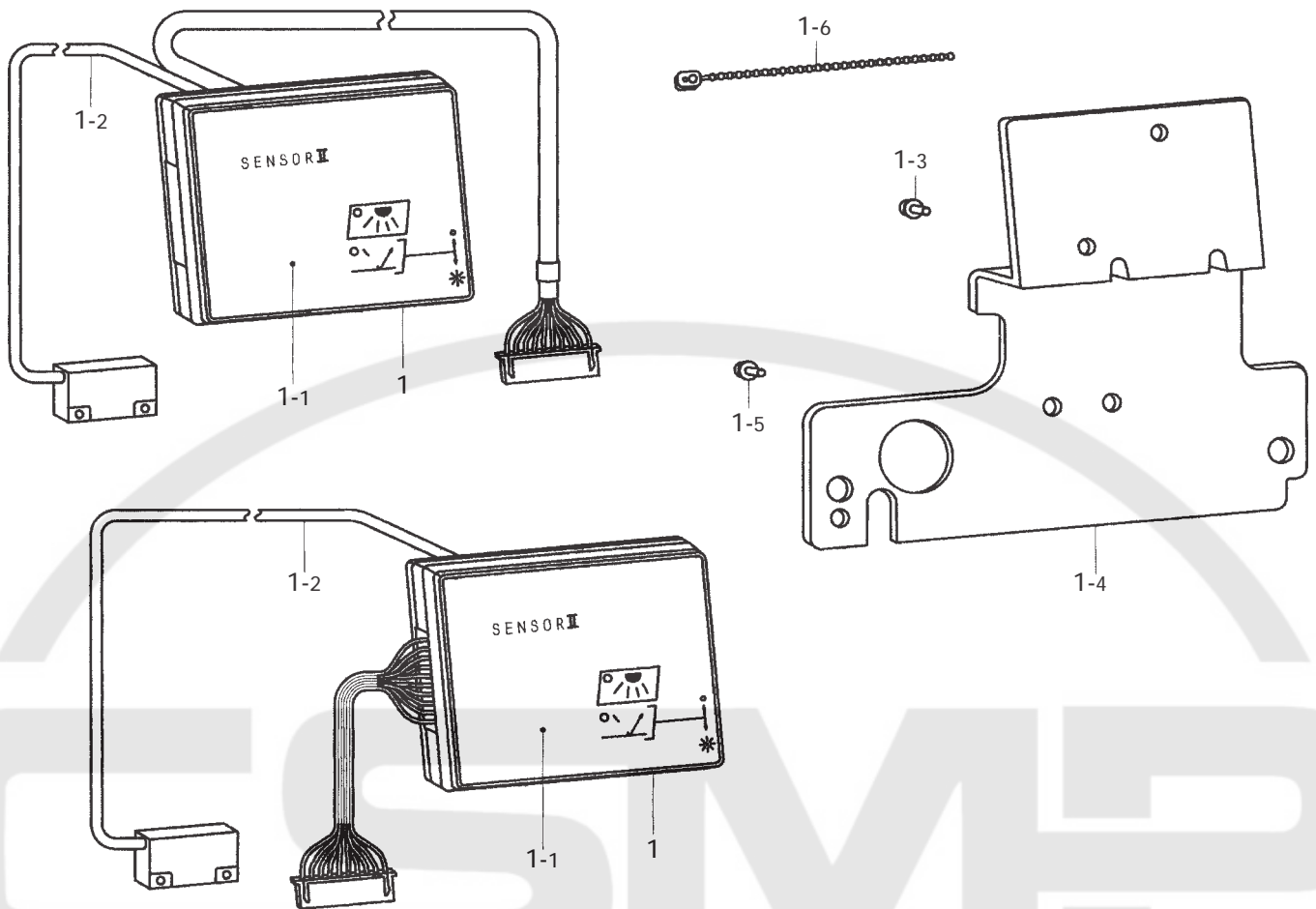

SENSOR SET (F-20 ~ F-100)

REF.NO.	MACHINE HEAD	737 ,748	TWIN NEEDLE	791	798
1	NAME OF PARTS CODE	SENSOR #2-2 291657-013	SENSOR #2-3 291674-011	SENSOR #2-4 291640-011	SENSOR #2-6 291642-011
1-1	EMBLEM PLATE	233268-002			
1-2	SENSOR CORD ASSY	233263-001		233619-001	233263-001
1-3	SCREW 4X10DB	215081-002			
1-4	SETTING PLATE	J03800-001	---		
1-5	SCREW 437-40X12	062681-212	---		
1-6	TIE BAND N-108	233501-001			

REF.NO.	MACHINE HEAD	774	722	728
1	NAME OF PARTS CODE	SENSOR #2-7 388706-011	SENSOR #2-41 J80793-001	SENSOR #2-61 J80870-001
1-1	EMBLEM PLATE	233268-002		
1-2	SENSOR CORD ASSY	233263-001		233619-001
1-3	SCREW 4X10DB	215081-002		
1-4	SETTING PLATE	---	J03800-001	---
1-5	SCREW 437-40X12	---	062681-212	---
1-6	TIE BAND N-108	233501-001		

G. Material edge sensor related (option) (2) / Für Materialkantensensor (Sonderausstattung) (2)
 Capteur de bord de tissu relatif (en option) (2) /
 Piezas relacionadas al detector de borde de tejidos (opcional) (2)

(737, 748)

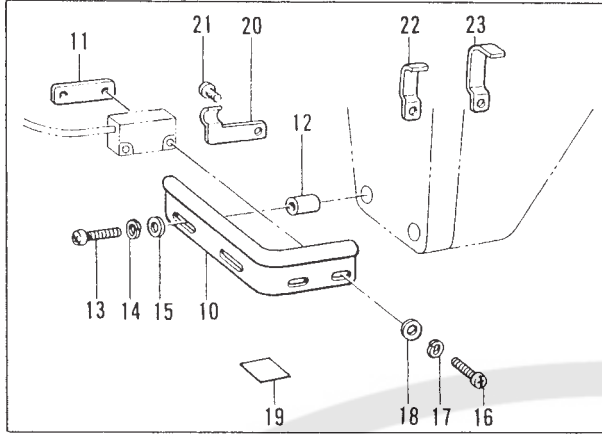

(842, 872)

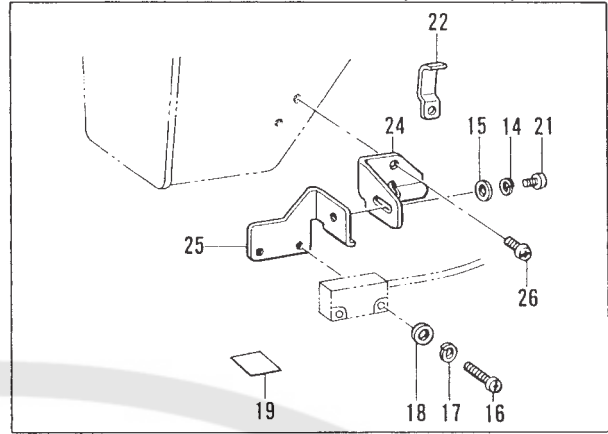

(791, 722)

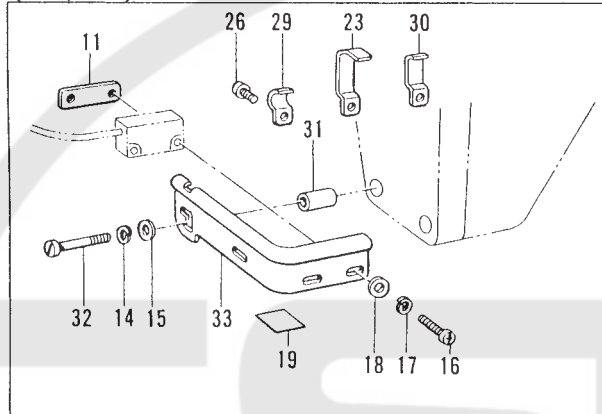

(798)

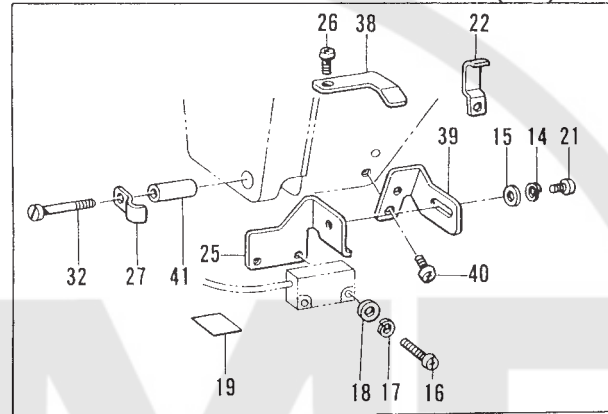

(728)

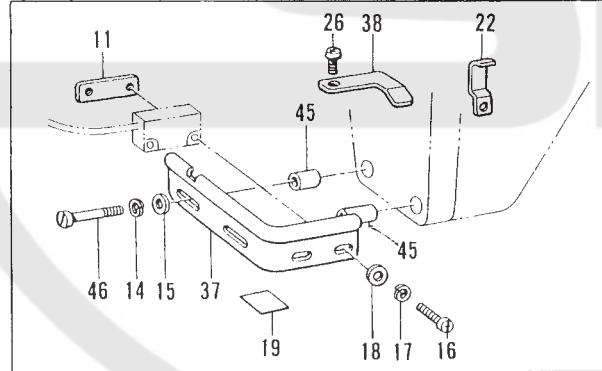

(774)

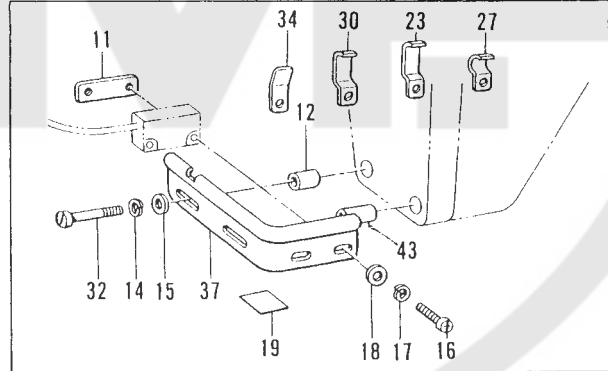

REF. NO.	CODE	Q' TY	NAME OF PARTS
10	233091-002	1	SENSOR PLATE
11	233092-001	1	SENSOR SETTING PLATE
12	233067-001	2	SENSOR SETTING COLLAR
13	062672-012	2	SCREW 3. 57-40X20
14	028350-242	2	SPRING WASHER 2-3. 5
15	026350-132	2	WASHER 3. 5
16	062301-402	2	SCREW 3X14
17	028030-242	2	SPRING WASHER 2-3
18	025030-132	2	WASHER 3
19	233063-001	1	ALUMINUM SHEET
20	233500-001	1	CORD HOLDER
21	062670-612	1	SCREW 3. 57-40X6
22	S02702-101	2	CORD HOLDER#U2
23	S02703-001	2	CORD HOLDER#U3
24	233545-001	1	SENSOR HOLDER#A
25	233544-001	1	SENSOR SETTING PLATE#3

REF. NO.	CODE	Q' TY	NAME OF PARTS
26	062680-812	2	SCREW 4. 37-40X8
27	S02701-001	2	CORD HOLDER#U1
29	233604-001	1	CORD HOLDER#2
30	142268-001	2	CORD HOLDER#L
31	233575-001	2	SENSOR SETTING COLLAR#2
32	151431-001	2	SCREW 3. 57
33	233573-001	1	SENSOR PLATE#B791
34	233618-001	1	CORD HOLDER#3
37	233574-001	1	SENSOR PLATE#B793
38	233696-001	1	CORD HOLDER#4
39	233694-001	1	SENSOR PLATE#B798
40	062670-812	1	SCREW 3. 57-40X8
41	233695-001	1	SENSOR SETTING COLLAR#3
43	236315-001	1	SENSOR COLLAR 17. 5
45	J03685-001	1	STUD BOLT 4. 37X31
46	062670-812	1	SCREW 3. 57-40X8

H. Pedal for standing operation / Fusstritt für stehenden Arbeitsplatz
 Pédale pour opération en station debò / Pedal para operar de pie

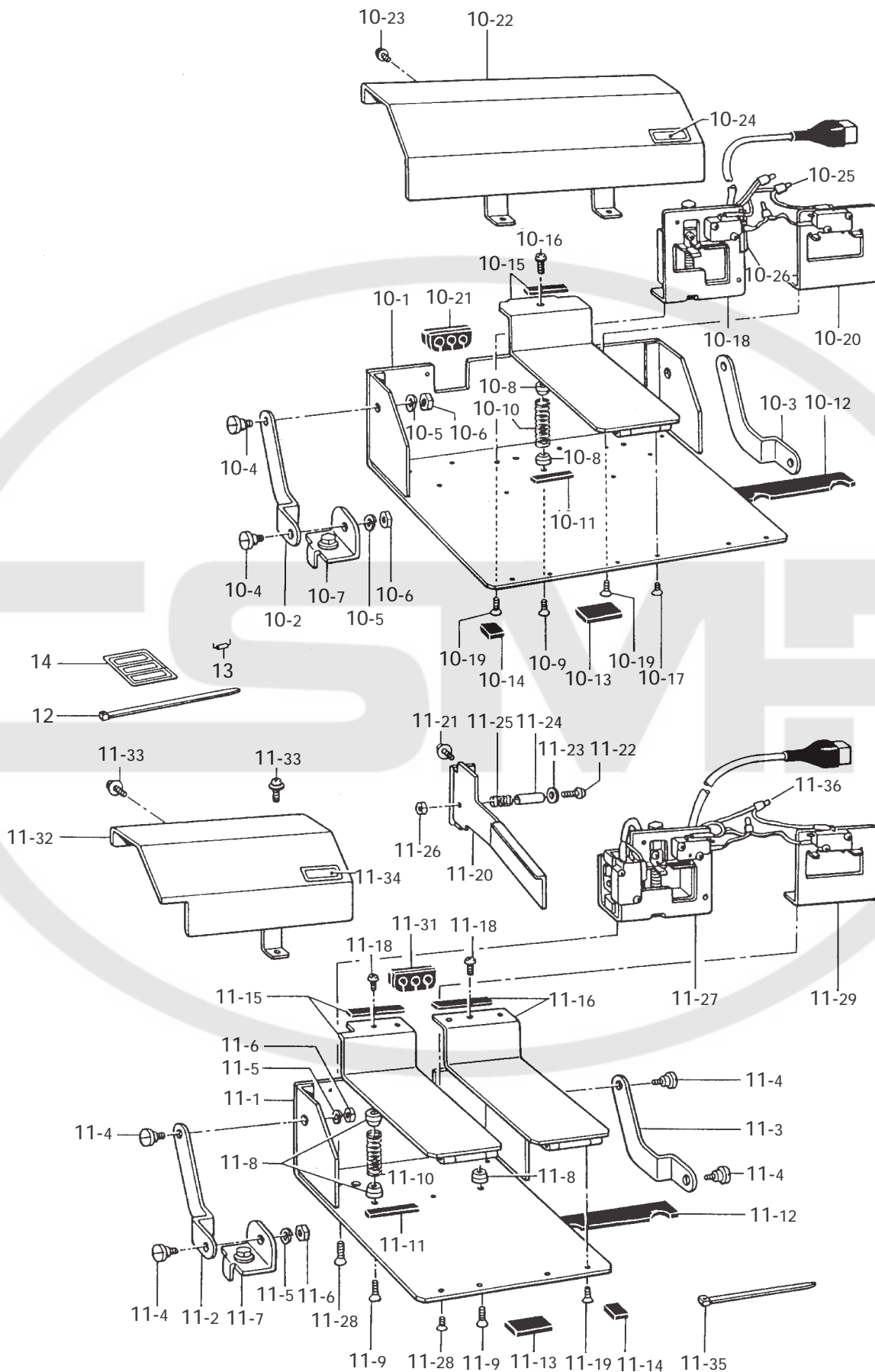

PEDAL FOR STANDING OPERATION
(VARIABLE SPEED TYPE) (TWO SPEED TYPE)

REF. NO.	CODE	Q' TY	NAME OF PARTS
10	*	1	PEDAL ASSEMBLY
10-1	233217-002	1	PEDAL BASE ASSEMBLY
10-2	233221-003	1	ARM CLAMP#L
10-3	233222-003	1	ARM CLAMP#R
10-4	233223-001	4	STUD SCREW 8X16.7
10-5	028080-242	4	SPRING WASHER 2-8
10-6	021080-302	4	NUT 8
10-7	233224-002	2	PEDAL CLAMP ASSEMBLY
10-8	233231-001	6	SPRING CUSHION#23
10-9	061401-205	3	SCREW 4X12
10-10	233233-001	3	SPRING 1.2X12X57
10-11	233232-001	3	RUBBER PLATE1. 6X5X45
10-12	233228-001	1	RUBBER PLATE3. 2X20X286
10-13	233229-001	2	RUBBER PLATE3. 2X20X46
10-14	233230-001	2	RUBBER PLATE3. 2X20X15
10-15	238188-001	3	PEDAL ASSEMBLY PRESSER
10-16	217093-001	3	SCREW 4X12D
10-17	061400-402	6	SCREW 4X4
10-18	*	1	SPEED CONTROLLER
10-19	061401-205	6	SCREW 4X12
10-20	J02950-001	2	M. SWITCH ASSEMBLY
10-21	233250-001	1	F. P BUSH
10-22	233251-003	1	PEDAL COVER
10-23	233236-001	4	SCREW 4X6DA
10-24	*	1	IDENTIFICATION LABEL
10-25	J01585-001	3	FLAT CONNECTOR CE1
10-26	233516-001	1	EDGING 2. 4X40
12	233491-001	2	TIE BAND 3. 6X203
13	200190-001	4	STAPLE
14	233515-001	1	LABEL

PEDAL FOR STANDING OPERATION
(SIDE ACTION AND VARIABLE SPEED TYPE)

REF. NO.	CODE	Q' TY	NAME OF PARTS
11	J80081-040	1	PEDAL THREAD TRIM #6
11-1	238194-001	1	PEDAL BASE ASSEMBLY#5
11-2	233221-003	1	ARM CLAMP#L
11-3	233222-003	1	ARM CLAMP#R
11-4	233223-001	4	STUD SCREW 8X16.7
11-5	028080-242	4	SPRING WASHER 2-8
11-6	021080-302	4	NUT 8
11-7	233224-002	2	PEDAL CLAMP ASSEMBLY
11-8	233231-001	4	SPRING CUSHION#23
11-9	061401-205	2	SCREW 4X12
11-10	233233-001	2	SPRING 1.2X12X57
11-11	233232-001	2	RUBBER PLATE1. 6X5X45
11-12	S14823-001	1	RUBBER PLATE3. 2X20X186
11-13	233229-001	1	RUBBER PLATE3. 2X20X46
11-14	233230-001	2	RUBBER PLATE3. 2X20X15
11-15	238186-001	1	PEDAL ASSEMBLY (SREED)
11-16	238188-001	1	PEDAL ASSEMBLY PRESSER
11-18	217093-001	1	SCREW 4X12D
11-19	061400-402	4	SCREW 4X4
11-20	238191-001	1	PEDAL TRIMMER ASS. #2
11-21	225534-001	2	SCREW 4X8DA
11-22	062402-005	1	SCREW 4X20
11-23	025040-335	1	WASHER 4
11-24	J00021-001	1	TUBE T5X12
11-25	228957-001	1	SPRING 8X30
11-26	021400-305	1	NUT 4
11-27	J01084-001	1	SPEED CONTROLLER#6
11-28	061401-205	4	SCREW 4X12
11-29	J02950-001	1	M. SWITCH ASSEMBLY
11-31	233250-001	1	F. P BUSH
11-32	238196-001	1	PEDAL COVER#5
11-33	233236-001	3	SCREW 4X6DA
11-34	J01089-001	1	IDENTIFICATION LABEL
11-35	228475-000	2	TIE BAND 1. 9X80
11-36	J00074-001	2	FLAT CONNECTOR CE2
12	233491-001	2	TIE BAND 3. 6X203
13	200190-001	4	STAPLE
14	233515-001	1	LABEL

DIFFERENT PARTS LIST

REF. NO.	NAME OF PARTS	VARIABLE SPEED TYPE	TWO SPEED TYPE
10	PEDAL ASSEMBLY	J80380-040	J80630-001
10-18	SPEED CONTROLLER	J01855-001	J02949-001
10-24	INDICATION LABEL	233487-002	233488-002

J. Synchronizer / Synchronisator / Synchroniseur / Sincronizador

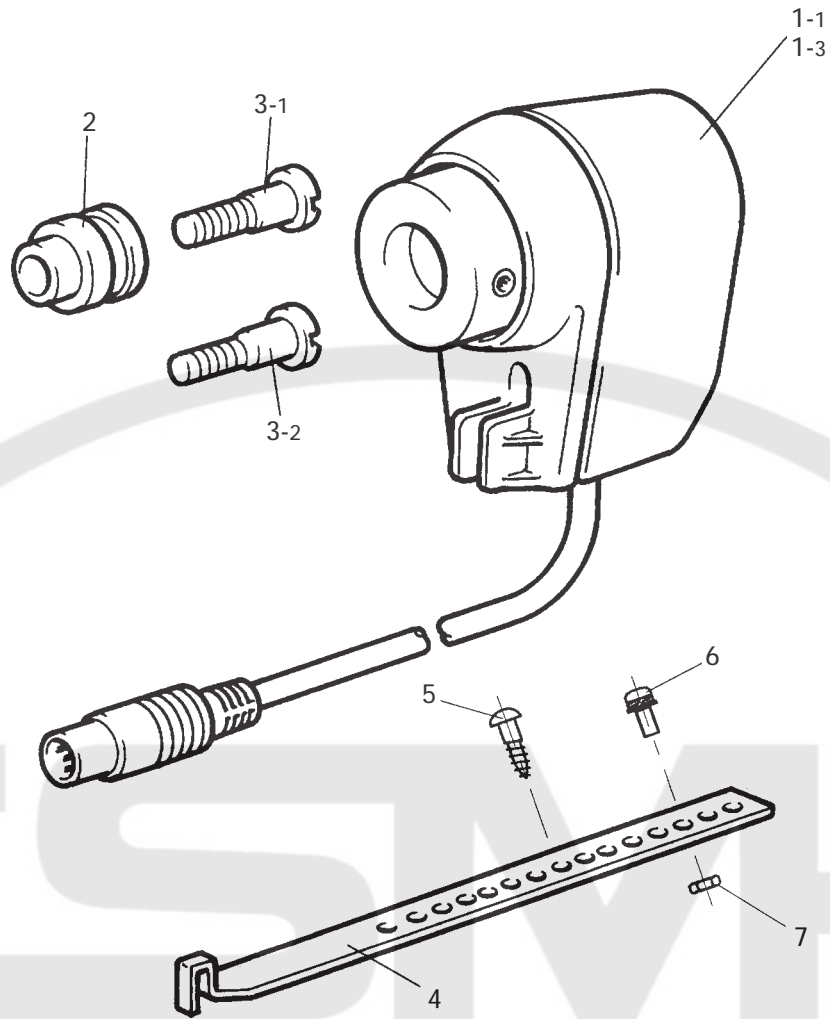

DIFFERENT PARTS LIST

REF. NO.	MACHINE HEAD		Others	C51,P73,P81
	NAME OF PARTS	Q'TY	CODE	CODE
1-1	SYNCHRONIZER ASSY#17-2	1	J80347-001	---
1-3	SYNCHRONIZER ASSY#17G8	1	---	J80859-001
2	SYNCHRO. BOSS 22.2	1	J01251-001	---
3-1	SCREW 11/32-28 (B,M)	1	J01252-001	---
3-2	SCREW 5/16-24 (J,S,A)	1	J01253-001	---
4	SYNCHRONIZER GUIDE	1	J01473-001	---
5	SCREW 4.5X16	2	S03816-001	---
6	SCREW 4X10DA	1	229017-001	---
7	NUT 3-4	1	021400-303	---

DIFFERENT PARTS LIST / ZUBEHÖRLISTE
 LISTE DES PIÈCES ACCESSOIRES / LISTA DE PIEZAS ACCESORIAS

MACHINE HEAD		Other than 883					
REF. NO.	POWER SUPPLY	Single Phase					Three Phase
		110 V	220 V	230,240 V	240 V(CE)	230 V(CE)	220 V
A-1	MOTOR ASSY	J80901-001					
A-24	TAPER PULLEY	J02278-001					
	90 105	J02281-001					
C-1	CONTROL BOX ASSY	J80905-001	J80906-001	J80907-001		J80908-001	J80909-001
C-2	POWER PCB ASSY	J80898-001	J80895-001		J80896-001		J80897-001
C-17	TRANSFORMER	J03711-001	J03710-001				
C-40	CONTROL PCB ASSY	J80900-001					
E1 ~ E15	SWITCH ASSY	229240-001	J01244-001		236127-001 (Australia)	J03134-001 (Europe)	229250-001
		J02045-001 (USA)	J02046-001 (OCR)			J02047-001 (USA)	
		230542-001 (Canada)	236127-001 (New Zealand)			J03238-001 (Greece)	230545-001 (Canada)
		237272-001 (Canada,OCR)	J03390-001 (Canada)			237273-001 (Canada,OCR)	
D30	EMC CORE					J80631-001	

MACHINE HEAD		883					
REF. NO.	POWER SUPPLY	Single Phase					Three Phase
		110 V	220 V	230,240 V	240 V(CE)	230 V(CE)	220 V
A-1	MOTOR ASSY	J80901-001					
A-24	TAPER PULLEY 90	J02278-001					
C-1	CONTROL BOX ASSY	J80905-001	J80906-001	J80907-001		J80908-001	J80909-001
C-2	POWER PCB ASSY	J80898-001	J80895-001		J80896-001		J80897-001
C-17	TRANSFORMER	J03711-001	J03710-001				
C-40	CONTROL PCB ASSY	J80900-001					
E22 ~ E33	SWITCH ASSY	J00452-001	J00460-001		J00464-001 (Australia)	J03313-001 (Europe)	J00470-001
		J00453-001 (USA)	J00462-001 (OCR)			J02432-001 (USA)	
		J00455-001 (Canada)	J00464-001 (New Zealand)			J03247-001 (Greece)	J00473-001 (Canada)
		J00457-001 (Canada,OCR)				J00477-001 (Canada,OCR)	
D30	EMC CORE					J80631-001	

INDEX/VERZEICHNIS
INDEX/INDICE

CODE	REF. NO.	CODE	REF. NO.
014500-632	B - 13	228475-000	H - 11-35
021080-206	A - 34	228957-001	H - 11-25
021080-302	H - 10-6 , H - 11-6	229017-001	A - 15 , A - 29 , C - 6
021100-206	A - 4		C - 13 , C - 26 , C - 30
021400-205	D - 26-2		C - 34 , C - 35 , C - 37-6
021400-303	J - 7		C - 39 , J - 6
021400-305	H - 11-26	229240-001	E - 1
025030-132	G - 18	229250-001	E - 12
025040-173	A - 10	230542-001	E - 2
025040-335	H - 11-23	230545-001	E - 13
025080-336	A - 32	233063-001	G - 19
025100-236	A - 5	233067-001	G - 12
025680-232	D - 32	233091-002	G - 10
026350-132	G - 15	233092-001	G - 11
028030-242	G - 17	233217-002	H - 10-1
028040-245	A - 9	233221-003	H - 10-2 , H - 11-2
028080-242	H - 10-5 , H - 11-5	233222-003	H - 10-3 , H - 11-3
028080-246	A - 33	233223-001	H - 10-4 , H - 11-4
028100-246	A - 6 , A - 21	233224-002	H - 10-7 , H - 11-7
028350-242	G - 14	233228-001	H - 10-12
037401-015	C - 37-4	233229-001	H - 10-13 , H - 11-13
061400-402	H - 10-17 , H - 11-19	233230-001	H - 10-14 , H - 11-14
061401-205	H - 10-9 , H - 10-19	233231-001	H - 10-8 , H - 11-8
	H - 11-9 , H - 11-28	233232-001	H - 10-11 , H - 11-11
062301-402	G - 16	233233-001	H - 10-10 , H - 11-10
062401-063	A - 8	233236-001	H - 10-23 , H - 11-33
062401-605	D - 26-1	233250-001	H - 10-21 , H - 11-31
062402-005	H - 11-22	233251-003	H - 10-22
062670-612	G - 21	233263-001	F - 1-2
062670-812	G - 40 , G - 46	233268-002	F - 1-1
062671-212	D - 7	233487-002	H - 10-24
062672-012	G - 13	233488-002	H - 10-24
062680-812	G - 26	233491-001	H - 12
062681-212	D - 6 , F - 1-5	233500-001	G - 20
076202-801	B - 11	233501-001	F - 1-6
085311-016	A - 13	233515-001	H - 14
0A4300-805	C - 11	233516-001	H - 10-26
0A4401-605	C - 27	233544-001	G - 25
0A4502-005	A - 19	233545-001	G - 24
BMP2070821F1000	D - 1	233573-001	G - 33
BMP2070121F1000	D - 12	233574-001	G - 37
BMP2070D21F4000	D - 27	233575-001	G - 31
BMP2070822F1000	D - 2	233604-001	G - 29
BMP2070122F1000	D - 13	233618-001	G - 34
BMP2070D22F4000	D - 28	233619-001	F - 1-2
BMP2070823F1000	D - 3	233694-001	G - 39
BMP2070123F1000	D - 14	233695-001	G - 41
BMP2070D23F4000	D - 29	233696-001	G - 38
BMP2070221F1000	D - 16	234618-001	A - 31
BMP2070222F1000	D - 17	236127-001	E - 6
BMP2070223F1000	D - 18	236315-001	G - 43
142268-001	G - 30	237272-001	E - 4
151431-001	G - 32	237273-001	E - 15
200190-001	A - 35 , H - 13	238186-001	H - 11-15
203684-001	B - 3	238188-001	H - 10-15 , H - 11-16
215081-002	D - 4 , F - 1-3	238191-001	H - 11-20
215082-003	A - 7	238194-001	H - 11-1
216205-000	A - 20	238196-001	H - 11-32
217093-001	H - 10-16 , H - 11-18	291640-011	F - 1
220681-001	C - 32	291642-011	F - 1
224485-000	B - 14-2	291657-013	F - 1
224508-001	D - 26-3	291674-011	F - 1
225534-001	H - 11-21	388706-011	F - 1

CODE	REF. NO.	CODE	REF. NO.
414959-001	C - 24	J03733-001	C - 41
J00021-001	H - 11-24	J03736-001	C - 3
J00074-001	H - 11-36	J03737-001	C - 12
J00351-001	A - 28	J03738-001	C - 28
J00353-001	C - 38	J03739-001	C - 31
J00452-001	E - 22	J03740-001	C - 4
J00453-001	E - 24	J03741-001	C - 7
J00455-001	E - 23	J03742-001	C - 8
J00457-001	E - 25	J03743-001	C - 14
J00460-001	E - 26	J03744-001	C - 25 , C - 33
J00461-001	E - 37-1	J03745-001	C - 19
J00462-001	E - 28	J03747-001	A - 12
J00464-001	E - 27	J03748-001	A - 14
J00470-001	E - 30	J03755-001	B - 1
J00473-001	E - 31	J03756-001	B - 2
J00477-001	E - 33	J03757-001	A - 23
J00649-001	C - 37-1-1	J03758-001	A - 2
J01084-001	H - 11-27	J03759-001	A - 3
J01089-001	H - 11-34	J03760-001	B - 5
J01244-001	E - 5 , E - 9-1	J03762-001	B - 6
J01251-001	J - 2	J03763-001	A - 25
J01252-001	J - 3-1	J03764-001	A - 26
J01253-001	J - 3-2	J03778-001	C - 18
J01354-001	C - 29	J03800-001	F - 1-4
J01411-001	C - 23	J03801-001	C - 10
J01463-001	B - 8	J03802-001	A - 16
J01473-001	J - 4	J03803-001	A - 17
J01585-001	H - 10-25	J03824-001	A - 11
J01855-001	H - 10-18	J03827-001	C - 37-5
J01988-001	D - 3-1	J03829-001	B - 4
J01989-001	D - 2-1	J03849-001	D - 16-1
J01990-001	D - 1-1	J03850-001	D - 17-1
J02039-001	C - 20	J03851-001	D - 18-1
J02045-001	E - 3	J03858-001	C - 37-1-2
J02046-001	E - 7	J03866-001	B - 1
J02047-001	E - 14	J03867-001	B - 2
J02054-001	D - 9	J03892-001	B - 9
J02058-001	D - 5	J80081-040	H - 11
J02059-001	D - 8	J80347-001	J - 1-1
J02061-001	D - 23	J80380-040	H - 10
J02130-001	C - 37-3	J80630-001	H - 10
J02195-001	C - 36	J80631-001	D - 30
J02278-001	A - 24	J80633-001	D - 15-1
J02281-001	A - 24	J80793-001	F - 1
J02293-001	A - 27	J80859-001	J - 1-3
J02302-001	E - 8-1	J80870-001	F - 1
J02432-001	E - 32	J80875-001	C - 37-2
J02493-001	A - 22	J80895-001	C - 2
J02525-001	B - 12	J80896-001	C - 2
J02566-001	D - 10	J80897-001	C - 2
J02567-001	D - 11	J80898-001	C - 2
J02568-001	C - 5 , C - 9	J80899-001	D - 15-2
J02824-001	C - 60	J80900-001	C - 40
J02832-001	A - 30	J80901-001	A - 1
J02949-001	H - 10-18	J80902-001	B - 7
J02950-001	H - 10-20 , H - 11-29	J80903-001	C - 37
J02997-001	B - 10 , B - 14	J80904-001	C - 37
J03134-001	E - 8	J80905-001	C - 1
J03238-001	E - 9	J80906-001	C - 1
J03247-001	E - 29	J80907-001	C - 1
J03313-001	E - 37	J80908-001	C - 1
J03390-001	E - 10	J80909-001	C - 1
J03555-001	D - 31	S02701-001	G - 27
J03588-001	E - 8-2 , E - 9-2	S02702-101	G - 22
J03634-002	C - 37-1	S02703-001	G - 23
J03637-001	C - 37-1-3	S03816-001	A - 36 , J - 5
J03674-002	C - 37-1	S14823-001	H - 11-12
J03685-001	G - 45	S38352-101	C - 16
J03710-001	C - 17	UK3745-000	C - 22
J03711-001	C - 17		

brother[®]



PARTS BOOK
TEILEKATALOG
LIVRE DES PIECES
LIBRO DE REFERENCIA DE PIEZAS

BROTHER INDUSTRIES, LTD. NAGOYA, JAPAN

Printed in Japan / Gedruckt in Japan / Imprimé au Japon / Impreso en Japón

137-602/612
J90115-101
2002.09. B