

brother

LK3-B438

高速本縫筒型ボタン付けマシン

HIGH-SPEED LOCK STITCH BUTTON SEWING MACHINE

VERRIEGELUNGSSTICH-SCHNELLNÄHER ZUM ANNÄHEN VON KNÖPFEN

MACHINE ULTRA-RAPIDE À POINT D'ARRÊT ET BRAS CYLINDRIQUE POUR
LA POSE DES BOUTONS

MÁQUINA DE COSER BOTONES DE COBLE PESPUNTE CON BARRA CILÍNDRICA
Y DE ALTA VELOCIDAD

パーツブック

PARTS BOOK

TEILEKATALOG

LIVRE DES PIECES

LIBRO DE REFERENCIA DE PIEZAS

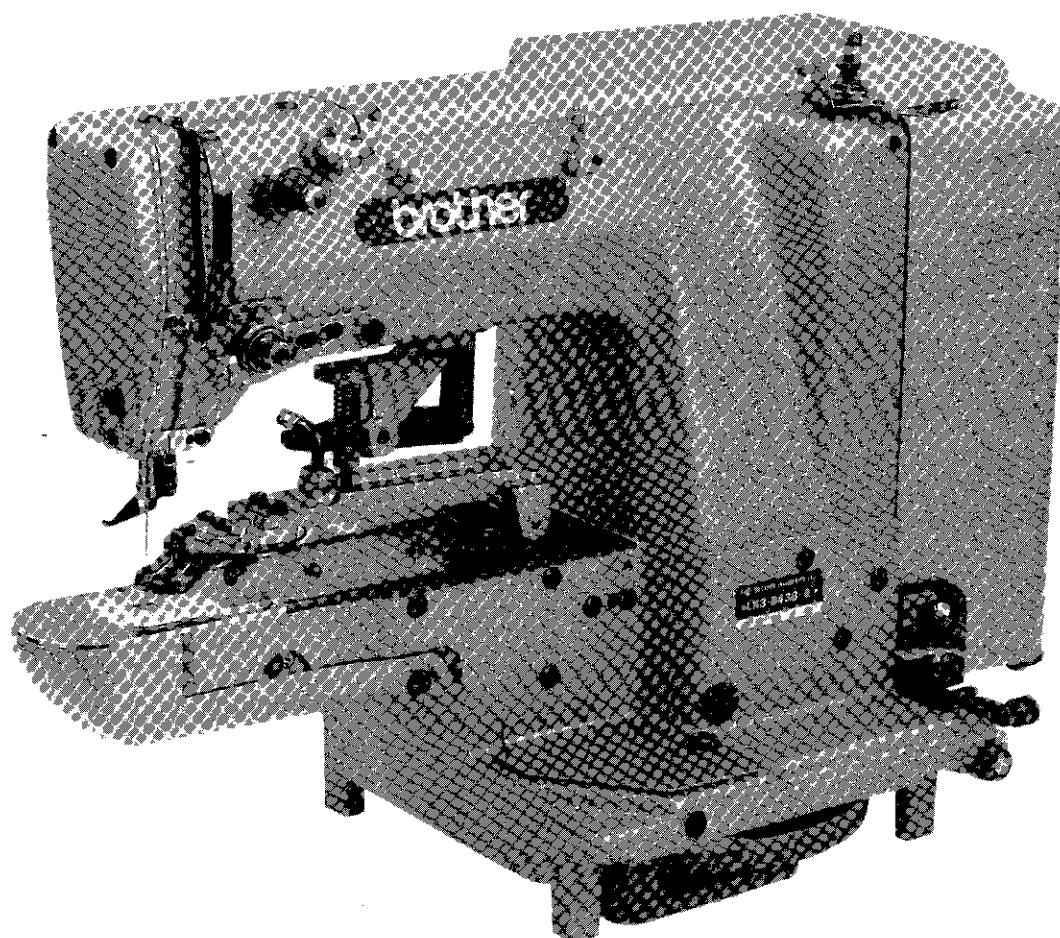

P438401



パーツブックご利用に際して

1. この本は、この本の表紙（正誤表の挿入されている場合は正誤表）に記載されているものと同じプレートが取り付けられているミシンのためのものです。
2. 部品コード欄が*となっている場合は、仕様別部品一覧表（45ページ）でお調べ下さい。
3. 補給対象外部品は、リストに掲載していません。補給対象外の子部品は、組コードでご注文下さい。
4. この本は1987年9月のデータに基づいて作成されたものです。
5. 部品は予告なしに設計変更される場合があります。

目 次

A. 主体関係	2
B. クラッチ関係	6
C. 上軸・針棒関係	10
D. パワー押エ関係	12
E. 送り関係	14
F. 押エ上げ関係	16
G. ボタンツマミ作動関係	18
H. カム伝導関係	20
J. 下軸関係	22
K. 給油・潤滑関係	24
L. 糸通シ関係	28
M. 糸巻き関係	30
N. 糸切り関係	32
P. 糸払い関係	34
Q. 糸締め関係	34
R. 動車・遊車関係	36
S. シャンクアタッチメント装置（特別注文部品）	36
Z. 付属品関係	38
特別注文部品	42
仕様別部品一覧表	45
索引	46

Notes for using this parts book

1. This book is applicable to sewing machines which have the same plate number as shown on the cover of this book (or correction sheet).
2. If the symbol * is found in the "Parts No." column, refer to the different parts list on page 45.
3. Parts which are not supplied separately are not included in the parts list. For assembly components of parts which are not supplied separately, order by the assembly number.
4. This book was prepared based on information available in September 1987.
5. Parts are subject to changes in design without prior notice.

CONTENTS

A. Machine body	2
B. Clutch mechanism	6
C. Upper shaft and needle bar mechanism	10
D. Power lift mechanism	12
E. Feed mechanism	14
F. Work clamp lifter mechanism	16
G. Button clamp mechanism	18
H. Feed cam mechanism	20
J. Lower shaft mechanism	22
K. Lubrication	24
L. Threading mechanism	28
M. Bobbin winder mechanism	30
N. Thread trimmer mechanism	32
P. Thread wiper mechanism	34
Q. Thread nipper mechanism	34
R. Drive pulley and idler pulley mechanism	36
S. Shank attachment (Option parts)	36
Z. Accessories	38
OPTION PARTS	42
DIFFERENT PARTS LIST	45
INDEX	46

Anmerkungen zum Gebrauch dieses Stücklistebuches

1. Dieses Buch bezieht sich auf die Nähmaschinen mit derselben Kennungsnummer wie auf diesem Buchumschlag (oder auf dem Korrekturblatt).
2. Dieses Zeichen * in der Spalte "Parts No. (Teilnummer)" verweist auf die Gesonderte Stückliste auf Seite 45.
3. In der Teileliste sind die Teile, die nicht separat lieferbar sind, nicht aufgeführt. Für die Bestellung dieser Teile wird auf die betreffende Bauteilnummer verwiesen.
4. Dieses Buch basiert auf den Informationen vom September 1987.
5. Modelländerungen sind vorbehalten.

INHALTSVERZEICHNIS

A. Maschinengehäuse	2
B. Kupplungsvorrichtung	6
C. Obere Welle und Nadelstange	10
D. Heberbetätigungsvorrichtung	12
E. Transportvorrichtung	14
F. Stoffhalterhebervorrichtung	16
G. Knopfhaltvorrichtung	18
H. Vertikale Welle	20
J. Untere Welle	22
K. Schmierung	24
L. Fadenführungsvorrichtung	28
M. Spuler	30
N. Fadenabschneidevorrichtung	32
P. Fadenwischvorrichtung	34
Q. Fadenspannvorrichtung	34
R. Antriebsriemenscheibe und Riemenscheibe	36
S. Knopfannähvorrichtung (Sonderzubehör)	36
Z. Zubehör	38
SONDERZUBEHÖR	42
ZUBEHÖRLISTE	45
VERZEICHNIS	46

Notes sur l'utilisation de ce manuel de pièces détachées

1. Ce manuel est destiné aux machines à coudre ayant le même numéro de plaque montré sur la couverture de ce manuel (ou sur la feuille de corrections).
2. Si le symbole * se trouve dans la colonne "Parts No. (N° de pièce)" veuillez la vous référer à la liste de pièces annexe page 45.
3. Les pièces fournies séparément ne sont pas comprises dans la liste des pièces. Pour ce qui concerne les composants de montage des pièces qui ne sont pas fournies séparément, faire les commandes en se reportant au numéro de montage.
4. Ce manuel a été fait d'après les renseignements valables au mois de Septembre 1987.
5. Les pièces peuvent être sujettes à des modifications sans préavis.

TABLE DES MATIERES

A. Corps de la machine	2
B. Mécanisme de l'embrayage	6
C. Mécanisme de arbre supérieur et barre à aiguille	10
D. Mécanisme de leueur	12
E. Mécanisme de l'entraînement	14
F. Mécanisme de leueur du pinceur	16
G. Mécanisme du pince-bowtons	18
H. Mécanisme d'arbre vertical	20
J. Mécanisme de l'arbre inférieur	22
K. Lubrification	24
L. Mécanisme de l'enfilage	28
M. Mécanisme de bobineur	30
N. Mécanisme de coupe-fil	32
P. Mécanisme de tire-fil	34
Q. Mécanisme de pince-fil	34
R. Mécanisme de poulie d'entraînement et poulie folle	36
S. Accessoire de talon (Pièces en option)	36
Z. Accessoires	38
PIECES EN OPTION	42
LISTE DES PIECES ACCESSOIRES	45
INDEX	46

Notas para usar este Libro de Piezas

1. Este libro sirve para todas las máquinas de coser que llevan la misma placa de identificación que la que se puede ver en la tapa de este libro (o en la hoja de erratas).
2. De haber un símbolo * junto al "Parts No. (Número de Pieza)", habrá que mirar la lista de piezas separada de la página 45.
3. Las piezas que no se venden por separado no se incluyen en la lista de piezas. Para las piezas individuales de un conjunto que no se venden por separado, realizar el pedido usando el número de pieza del conjunto.
4. Este libro ha sido compilado basándose en los datos de que se disponía en septiembre 1987.
5. Las piezas quedan sujetas a cambios de diseño sin aviso previo.

INDICE

A. Cuerpo de la máquina	2
B. Mecanismo de embrague	6
C. Mecanismo de eje superior y barra de aguja	10
D. Mecanismo de carreta de potencia	12
E. Mecanismo de la alimentación	14
F. Mecanismo de levantador de ménsula de trabajo	16
G. Mecanismo de la ménsula de resorte	18
H. Mecanismo de eje vertical	20
J. Mecanismo de la eje inferior	22
K. Lubricación	24
L. Mecanismo de la enhebrado	28
M. Mecanismo del devanador de la canilla	30
N. Mecanismo de recortadora de orillos	32
P. Mecanismo de limpiador de hilos	34
Q. Mecanismo de mordaza para hilos	34
R. Mecanismo de polea impulsora y polea tensora	36
S. Mecanismo de la caña (Piezas opcion)	36
Z. Accesorios	38
PIEZAS EN OPCION	42
LISTA DE PIEZAS ACCESORIAS	45
INDICE	46

A. 主体関係 / Machine body / Maschinengehäuse /
 Corps de la machine / Cuerpo de la máquina

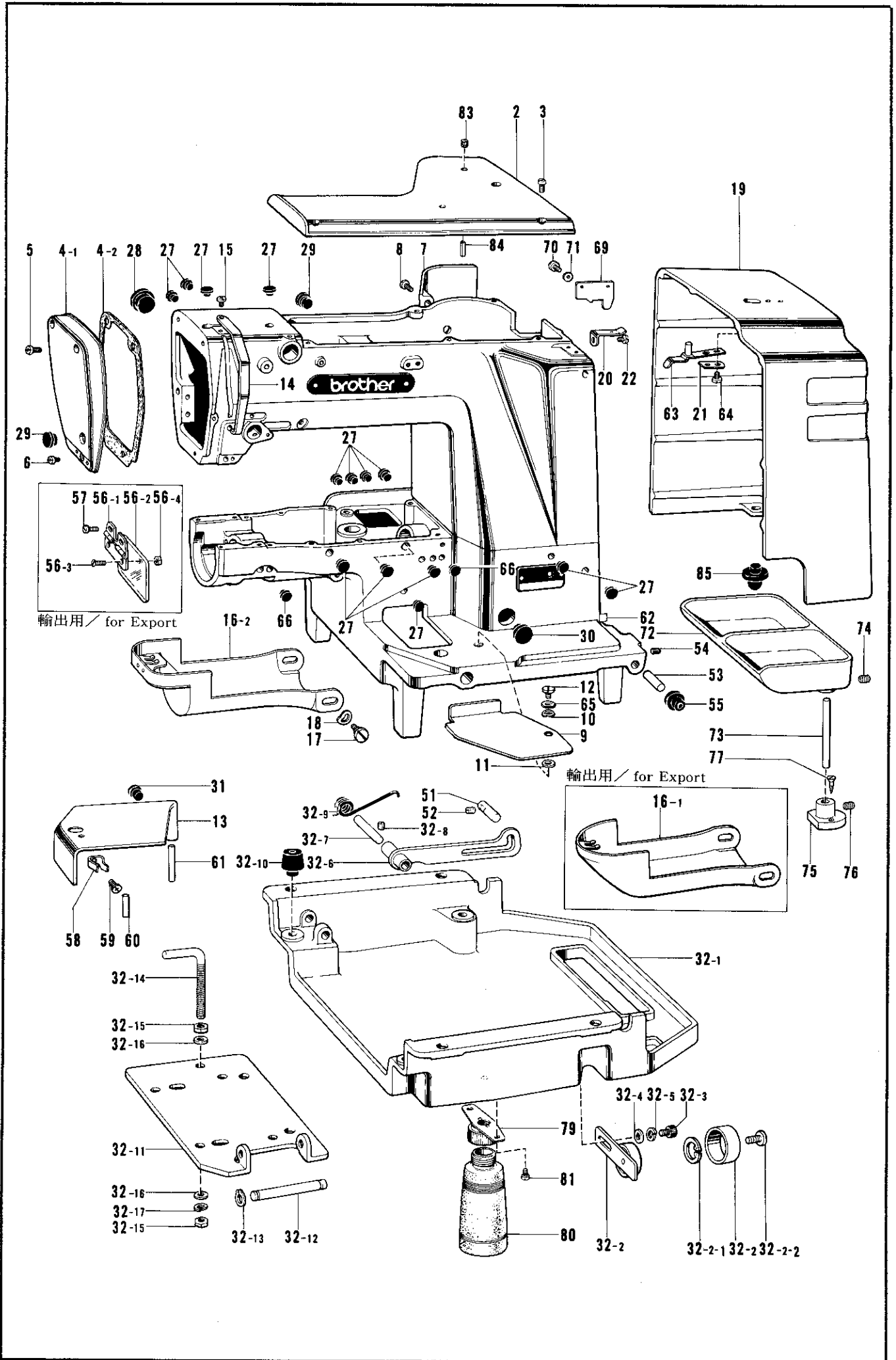

A. 主体関係 / Machine body / Maschinengehäuse /
Corps de la machine / Cuerpo de la máquina

REF.NO.	CODE	Q'TY	ヒンメイ	NAME OF PARTS	RMKS
2	152830106	1	ウフフタ	TOP COVER	
3	062761412	6	ナヘ"コ595-28X14	SCREW 595-28X14	
4	152831006	1	メンイタクミ	FACE PLATE ASSEMBLY	
4-1	152832106	1	メンイタ	FACE PLATE	
4-2	152833001	1	メンイタハ"ツキン	PACKING	
5	062711412	2	ナヘ"コ476-32X14	SCREW 476-32X14	
6	062710712	1	ナヘ"コ476-32X7	SCREW 476-32X7	
7	153868106	1	ソクメンカハ"	SIDE COVER	
8	062711412	4	ナヘ"コ476-32X14	SCREW 476-32X14	
9	152835006	1	ヘ"ツト"カハ"-R	BED COVER (R)	
10	100315002	1	ナミハ"ネ	WASHER	
11	025770232	1	ヒラサ"ガ"ネチユウ6.35	WASHER 6.35	
12	145480001	1	タ"ンネシ"6.35	STUD SCREW 6.35	
13	152836006	1	ヘ"ツト"カハ"-Lクミ	BED COVER (L) ASSEMBLY	
14	152841003	1	デンヒ"ンカハ"-	THREAD TAKE-UP COVER	
15	062670812	1	ナヘ"コ357-40X8	SCREW 357-40X8	
16-1	152842006	1	-----	SHUTTLE RACE COVER ASSEMBLY	
16-2	S01888006	1	オオカマカハ"-クミC	-----	
17	115493002	2	タ"ンネシ"5.95	STUD SCREW 5.95	
18	109239002	2	ナミハ"ネサ"ガ"ネ	WASHER	
19	152846006	1	ヘ"ルトカハ"-	BELT COVER	
20	152989001	1	ヘ"ルトカハ"-ハ"ネウケ	BELT COVER SPRING PLATE	
21	152986001	1	ヘ"ルトカハ"-ハ"ネササエ	BELT COVER STOPPER	
22	062680812	1	ナヘ"コ437-40X8	SCREW 437-40X8	
27	117936001	14	メクラセン	OIL CAP	
28	140392001	1	オイルフタ	OIL CAP	
29	117934001	2	メクラセン	OIL CAP	
30	108520001	1	メクラセン	OIL CAP	
31	104450101	1	メクラセン	OIL CAP	
32	159808001	1	オイルパンクミ	OIL PAN ASSEMBLY	
32-1	154738101	1	オイルパン	OIL PAN	
32-2	152852101	1	テンションプ-リクミ	TENSION PULLEY ASSEMBLY	
32-2-1	048320242	1	トメワアナヨウC32	STOP RING C32	
32-2-2	141860001	1	シメネシ"6.35	SCREW 6.35	
32-3	018081222	1	アナホ"ルト8X12	BOLT 8X12	
32-4	025080232	1	ヒラサ"ガ"ネチユウ8	WASHER 8	
32-5	028080242	1	ハ"ネサ"ガ"ネ2-8	SPRING WASHER 2-8	
32-6	152857001	1	トウフ"ササエレハ"-	HEAD SUPPORTER LEVER	
32-7	152858001	1	トウフ"ササエレハ"-シ"ク	HEAD SUPPORTER LEVER SHAFT	
32-8	013719412	1	トメネシ"4.76クホ"ミ	SCREW 4.76	
32-9	152859001	1	トウフ"ササエレハ"-ハ"ネ	HEAD SUPPORTER LEVER SPRING	
32-10	152860001	4	ヘ"ツト"クツシヨン	BED CUSHION	
32-11	152861101	1	モ-タータ"イ	MOTOR BASE PLATE	
32-12	152862001	1	モ-タータ"イシ"ク	MOTOR BASE PLATE SHAFT	
32-13	048100142	2	トメワシ"クヨウC10	STOP RING C10	
32-14	152865101	1	Lカ"タホ"ルトM10	L BOLT M10	
32-15	021100202	2	ナツト2シユ10	NUT 10	
32-16	025100132	2	ヒラサ"ガ"ネシヨウ10	WASHER 10	
32-17	028100242	1	ハ"ネサ"ガ"ネ2-10	SPRING WASHER 2-10	
51	152866001	1	トウフ"ササエヒン	HEAD SUPPORTER PIN	
52	013760612	1	トメネシ"5.95クホ"ミ	SCREW 5.95	
53	152867000	2	ヘ"ツト"ヒンシ"シ"ク	HINGE SHAFT	
54	151604002	2	トメネシ"5.95	SCREW 5.95	
55	152868000	2	ヘ"ツト"ヒンシ"クツシヨン	HEAD CUSHION	
56	153100000	1	-----	EYE GUARD ASSEMBLY	
56-1	153102001	1	-----	EYE GUARD HINGE ASSEMBLY	
56-2	153098000	1	-----	EYE GUARD	
56-3	102538007	2	-----	SCREW 3.57	
56-4	106129001	2	-----	NUT 3.57	
57	062670512	2	-----	SCREW 357-40X5	
58	114985001	1	ヘ"ツトカハ"-トメハ"ネ	BED COVER STOP SPRING	
59	062680612	1	ナヘ"コ437-40X6	SCREW 437-40X6	

A. 主体関係 / Machine body / Maschinengehäuse /
Corps de la machine / Cuerpo de la máquina

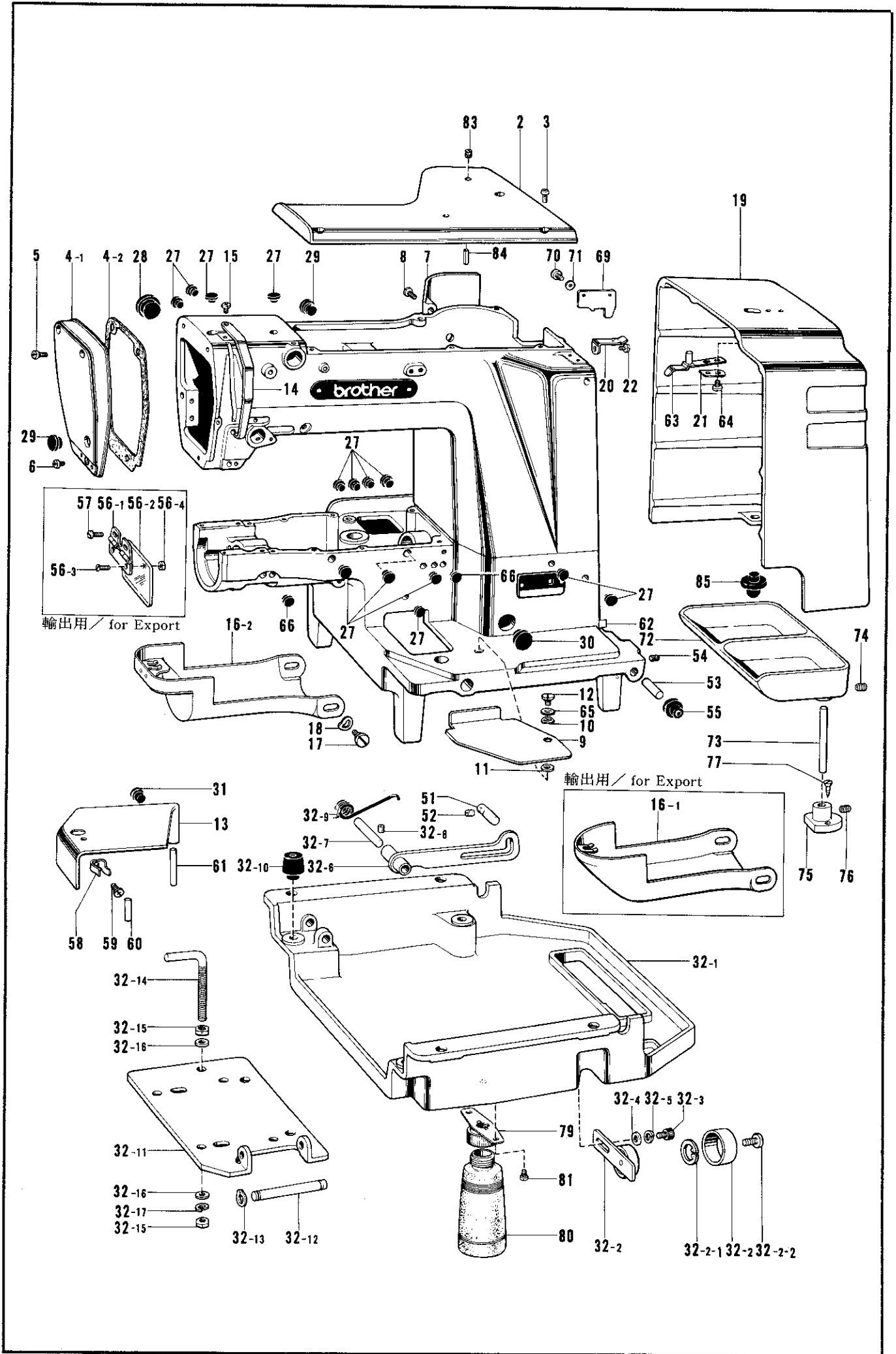

A. 主体関係 / Machine body / Maschinengehäuse /
Corps de la machine / Cuerpo de la máquina

REF.NO.	CODE	Q'TY	ヒンメイ	NAME OF PARTS	RMKS
60	152838001	1	ミソツキピン	GROOVED PIN	
61	152839001	1	ベッドカバーシャフト	BED COVER SHAFT	
62	*	1	シヨウラベル	LABEL	
63	152848001	1	ベルトカバーバネ	BELT COVER SPRING	
64	062680812	2	ナベコ437-40X8	SCREW 437-40X8	
65	025080132	1	ヒラサガネシヨウ8	WASHER 8	
66	104450101	2	メクラセン	OIL CAP	
69	*	1	ハリカスキリカエキ	STITCH REGULATOR	
70	062680612	2	ナベコ437-40X6	SCREW 437-40X6	
71	025680132	2	ヒラサガネシヨウ4.37	WASHER 4.37	
72	115270006	1	ボタンサラ	BUTTON TRAY	
73	115160001	2	ボタンサラアシ	BUTTON TRAY LEG	
74	014770622	2	アナトメネシ6.35クホミ	SCREW 6.35	
75	153843006	1	ボタンサラアシホルダ	BUTTON TRAY HOLDER	
76	014760622	1	アナトメネシ5.95クホミ	SCREW 5.95	
77	101795001	2	サラモクネシ3.5X16	SCREW 3.5X16	
79	154465001	1	ハイユキヤツプササエクミ	DUST OILER SUPPORTER	
80	114486002	1	ホリオイラータイ	OILER	
81	062710612	2	ナベコ476-32X6	SCREW 476-32X6	
83	154785000	2	フェルト	FELT	
84	047501242	2	スプリングピンAW5	SPRING PIN AW5	
85	152847000	2	ベルトカバーゴムサ	PACKING	

B. クラッチ関係 / Clutch mechanism / Kupplungsvorrichtung /
 Mécanisme de l'embrayage / Mecanismo de embrague

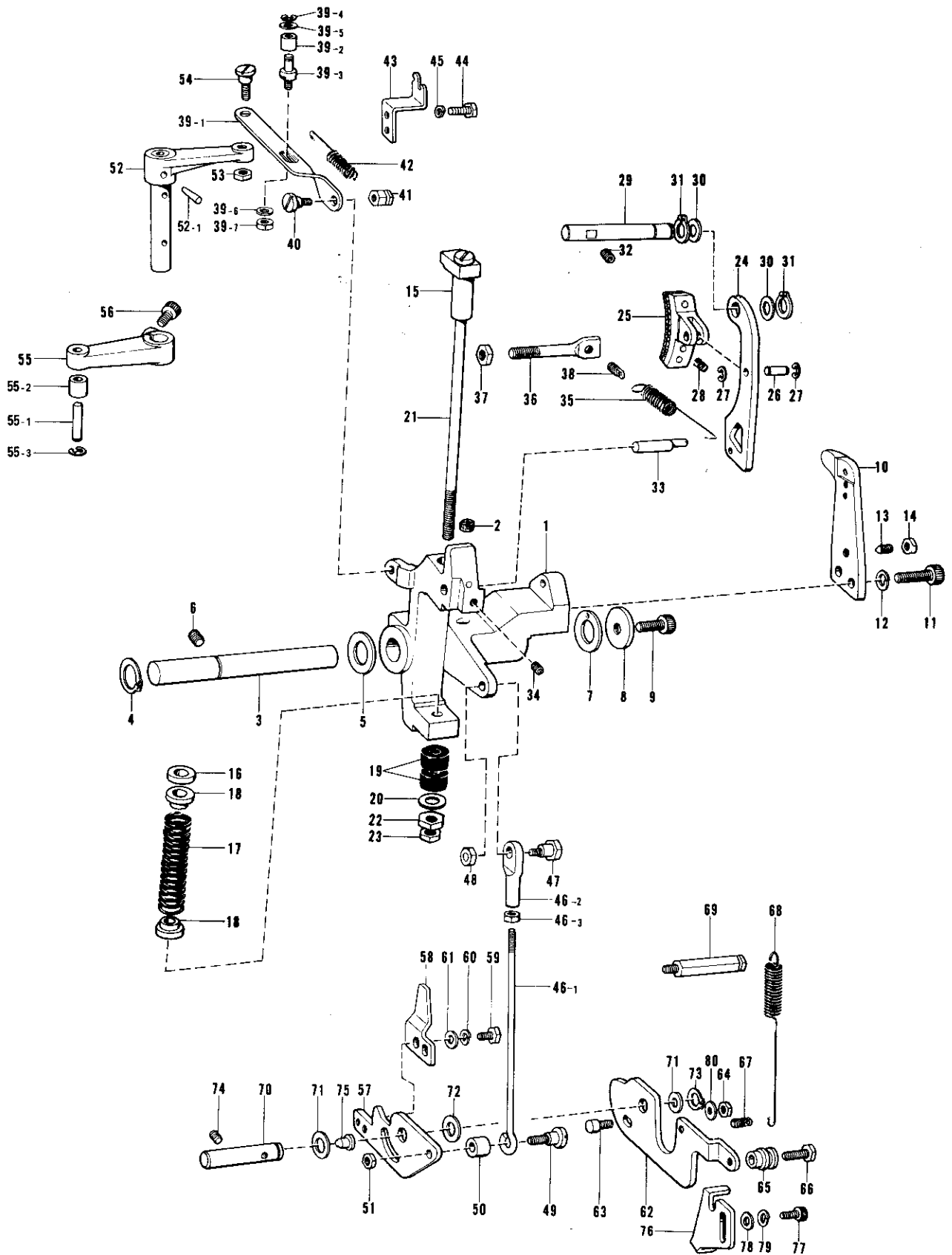

B. クラッチ関係 / Clutch mechanism / Kupplungsvorrichtung /
Mécanisme de l'embrayage / Mecanismo de embrague

REF.NO.	CODE	Q'TY	ヒンメイ	NAME OF PARTS	RMKS
1	151886001	1	クラッチレバー	CLUTCH LEVER	
2	151927001	1	クラッチフェルト	CLUTCH FELT	
3	151887001	1	クラッチレバーシフト	CLUTCH LEVER SHAFT	
4	048180142	1	トメワC18	STOP RING C18	
5	152756001	1	スラストサ"カ"ネ18	THRUST WASHER 18	
6	014821022	1	アナトメネジ"7.94クホ"ミ	SCREW 7.94	
7	151929000	1	スラストサ"カ"ネ18	THRUST WASHER 18	
8	152728001	1	スラストサ"カ"ネ8	THRUST WASHER 8	
9	151163001	1	アナボ"ルト8X15	BOLT 8X15	
10	151888101	1	ボールオサエイタ	BALL PRESSER PLATE	
11	018082522	2	アナボ"ルト8X25	BOLT 8X25	
12	028080242	2	ハ"ネサ"カ"ネ2-8	SPRING WASHER 2-8	
13	115012002	1	トメネジ"6.35	SCREW 6.35	
14	150554002	1	ナツト6.35	NUT 6.35	
15	151889001	1	ストツパ°タイ	CLUTCH STOPPER	
16	151890000	1	ストツパ°ゴム	CUSHION RUBBER	
17	151891001	1	クラッチハ"ネ	CLUTCH SPRING	
18	151892001	2	ハ"ネウケ	SPRING HOLDER	
19	115018001	2	カンシヨウゴム	CUSHION RUBBER	
20	025800332	1	ヒラサ"カ"ネタ"イ7.14	WASHER 7.14	
21	151893001	1	ストツパ°シク	STOPPER BAR	
22	021800102	1	ナツト1シユ7.14	NUT 7.14	
23	104689002	1	ナツト7.14	NUT 7.14	
24	151894101	1	ブレーキレバー	BRAKE LEVER	
25	151895000	1	ブレーキクミ	BRAKE ASSEMBLY	
26	151898001	1	ブレーキシク	BRAKE SHAFT	
27	048040342	2	トメワE4	STOP RING E4	
28	151899001	1	ブレーキシユ-ハ"ネ	SPRING	
29	151900001	1	ブレーキレバーシク	BRAKE LEVER SHAFT	
30	142628001	2	スイハイオクリクランクリンク"	HORIZONTAL FEED CRANK RING	
31	048110142	2	トメワシクヨウC11	STOP RING C11	
32	013761410	1	トメネジ"5.95クホ"ミ	SCREW 5.95	
33	151901001	1	ブレーキサト"-ピン	BRAKE SLIDE PIN	
34	014760622	1	アナトメネジ"5.95クホ"ミ	SCREW 5.95	
35	151902001	1	ブレーキハ"ネ	BRAKE SPRING	
36	151903001	1	ブレーキハ"ネカケネジ"	SPRING HOOK	
37	106147002	1	ナツト7.94	NUT 7.94	
38	110251001	1	ヌノオサエウテ"ハ"ネカケ	SPRING HOOK	
39	151904101	1	クラッチレバーレンカンクミ	CLUTCH LEVER ROD ASSEMBLY	
39-1	151905101	1	クラッチレバーレンカン	CLUTCH LEVER ROD	
39-2	107744001	1	コロ	ROLLER	
39-3	151906101	1	レンカンコロシク	ROLLER STUD	
39-4	048030342	1	トメワE3	STOP RING E3	
39-5	113431002	1	サ"カ"ネ	WASHER	
39-6	025680132	1	ヒラサ"カ"ネシヨウ4.37	WASHER 4.37	
39-7	021680202	1	ナツト2シユ4.37	NUT 4.37	
40	151907001	1	タ"ンネジ"5.95	STUD SCREW 5.95	
41	151908001	1	ナツト5.95	NUT 5.95	
42	155501001	1	クラッチレバーハ"ネ	CLUTCH LEVER SPRING	
43	151910001	1	クラッチレバーハ"ネカケ	SPRING HOOK	
44	117363001	2	ボ"ルト4.76	BOLT 4.76	
45	028050242	2	ハ"ネサ"カ"ネ2-5	SPRING WASHER 2-5	
46	152808101	1	チヨウセツツツ"クミ	CONNECTING ROD ASSEMBLY	
46-1	154332001	1	オサエアケ"チヨウセツツツ"	CONNECTING ROD	
46-2	154333001	1	オサエアケ"チヨウセツツキ"テ	CONNECTING JOINT	
46-3	150556001	1	ナツト6.35	NUT 6.35	
47	151912001	1	ヘンシンタ"ンネジ"6.35	STUD SCREW 6.35	
48	150556001	1	ナツト6.35	NUT 6.35	
49	151913001	1	タ"ンネジ"6.35	STUD SCREW 6.35	
50	151914001	1	カラー13	COLLAR 13	
51	150556001	1	ナツト6.35	NUT 6.35	
52	151915001	1	クラッチサト"-レバ"ークミ	CLUTCH ACTUATING LEVER ASSEMBLY	

B. クラッチ関係 / Clutch mechanism / Kupplungsvorrichtung /
 Mécanisme de l'embrayage / Mecanismo de embraque

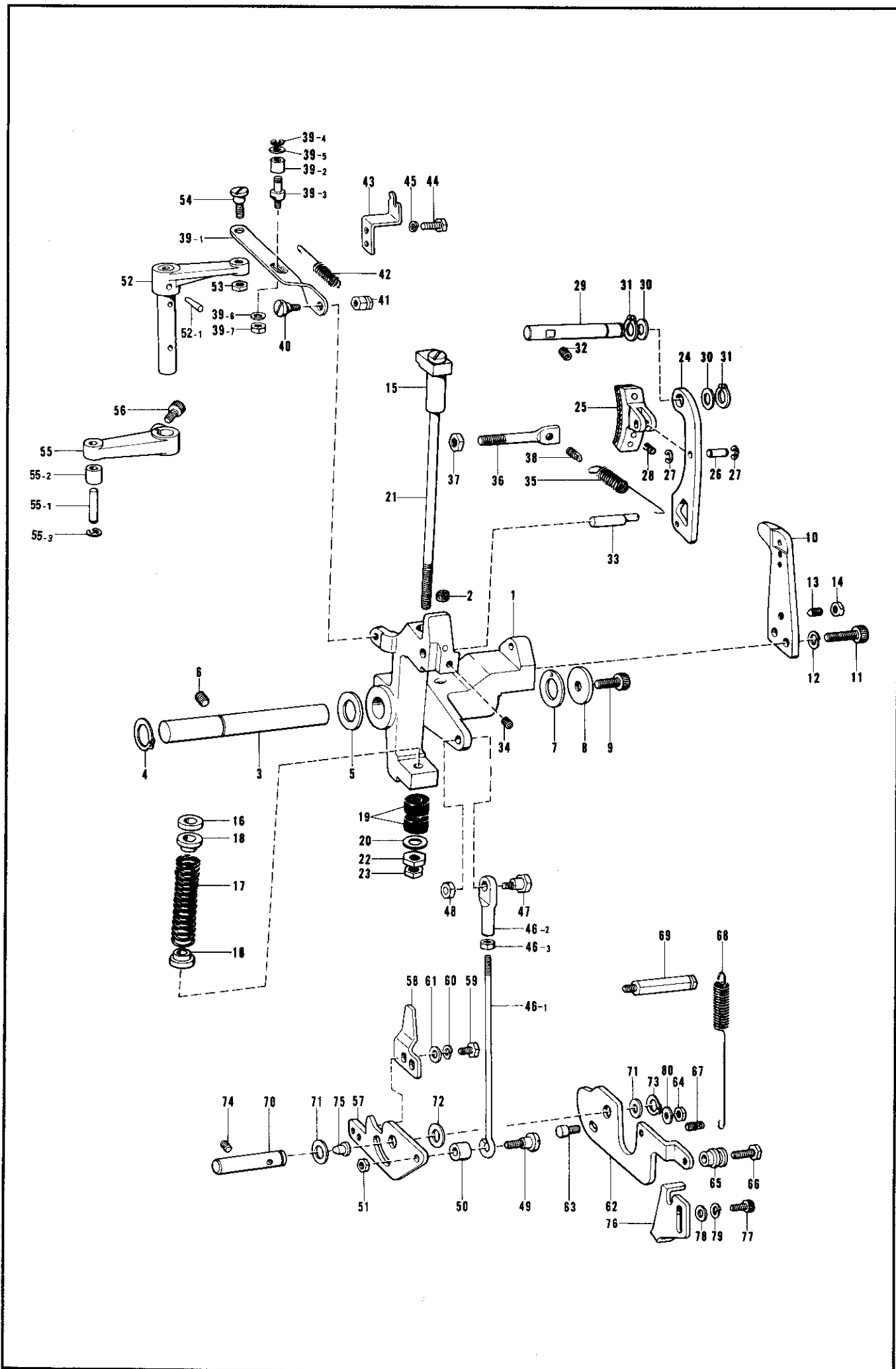

B. クラッチ関係 / Clutch mechanism / Kupplungsvorrichtung /
Mécánisme de l'embrayage / Mecanismo de embrague

REF.NO.	CODE	Q'TY	ヒンメイ	NAME OF PARTS	RMKS
52-1	107030001	1	テーパ°ピン	TAPER PIN	
53	150553001	1	ナツト5.95	NUT 5.95	
54	151907001	1	タ°ンネシ°5.95	STUD SCREW 5.95	
55	151939001	1	クラツチカムレハ°ークミ	CLUTCH CAM LEVER ASSEMBLY	
55-1	152913001	1	コロシ°ク	ROLLER STUD	
55-2	152914001	1	コロ	ROLLER	
55-3	048040342	1	トメワE4	STOP RING E4	
56	018062022	1	アナホ°ルト6X20	BOLT 6X20	
57	151919101	1	キト°ーレハ°ー	STARTING LEVER	
58	151920001	1	キト°ーセイフレハ°ー	STARTING SAFETY LEVER	
59	017711412	2	ホ°ルト4.76X14	BOLT 4.76X14	
60	028050242	2	ハ°ネサ°カ°ネ2-5	SPRING WASHER 2-5	
61	113431002	2	サ°カ°ネ	WASHER	
62	155499001	1	Pサト°ーレハ°ー	STARTING LEVER PLATE	
63	154155101	1	ストツハ°ネシ°	STOPPER SCREW	
64	150553001	1	ナツト5.95	NUT 5.95	
65	151922001	1	クザリカケカラ°ー	CHAIN HOOK	
66	017762202	1	ホ°ルト5.95X22	BOLT 5.95X22	
67	110251001	1	ヌノオサエウテ°ハ°ネカケ	SPRING HOOK	
68	151923001	1	サト°ーレハ°ー°ハ°ネ	SPRING	
69	151924001	1	サト°ーレハ°ー°ハ°ネカケ	SPRING HOOK	
70	151925001	1	キト°ーレハ°ー°ジ°ク	STARTING LEVER SHAFT	
71	142628001	2	スイヘイオクリクランク°リング°	HORIZONTAL FEED CRANK RING	
72	110505001	1	サ°カ°ネ	WASHER	
73	048110142	1	トメワシ°クヨウC11	STOP RING C11	
74	014760622	1	アナトメネシ°5.95クホ°ミ	SCREW 5.95	
75	111865001	1	オイルメクラセン	CAP FOR OIL INLET	
76	155500001	1	キト°ー°ストツハ°	STARTING LEVER STOPPER	
77	018061622	2	アナホ°°ルト6X16	BOLT 6X16	
78	025060132	2	ヒラサ°カ°ネシヨウ6	WASHER 6	
79	028060242	2	ハ°ネサ°カ°ネ2-6	SPRING WASHER 2-6	
80	025060232	1	ヒラサ°カ°ネチユウ6	WASHER 6	

C. 上軸・針棒関係/Upper shaft and needle bar mechanism/Obere Welle und Nadelstange/
 Mécanisme de arbre supérieur et barre à aiguille/Mecanismo de carreta de potencia

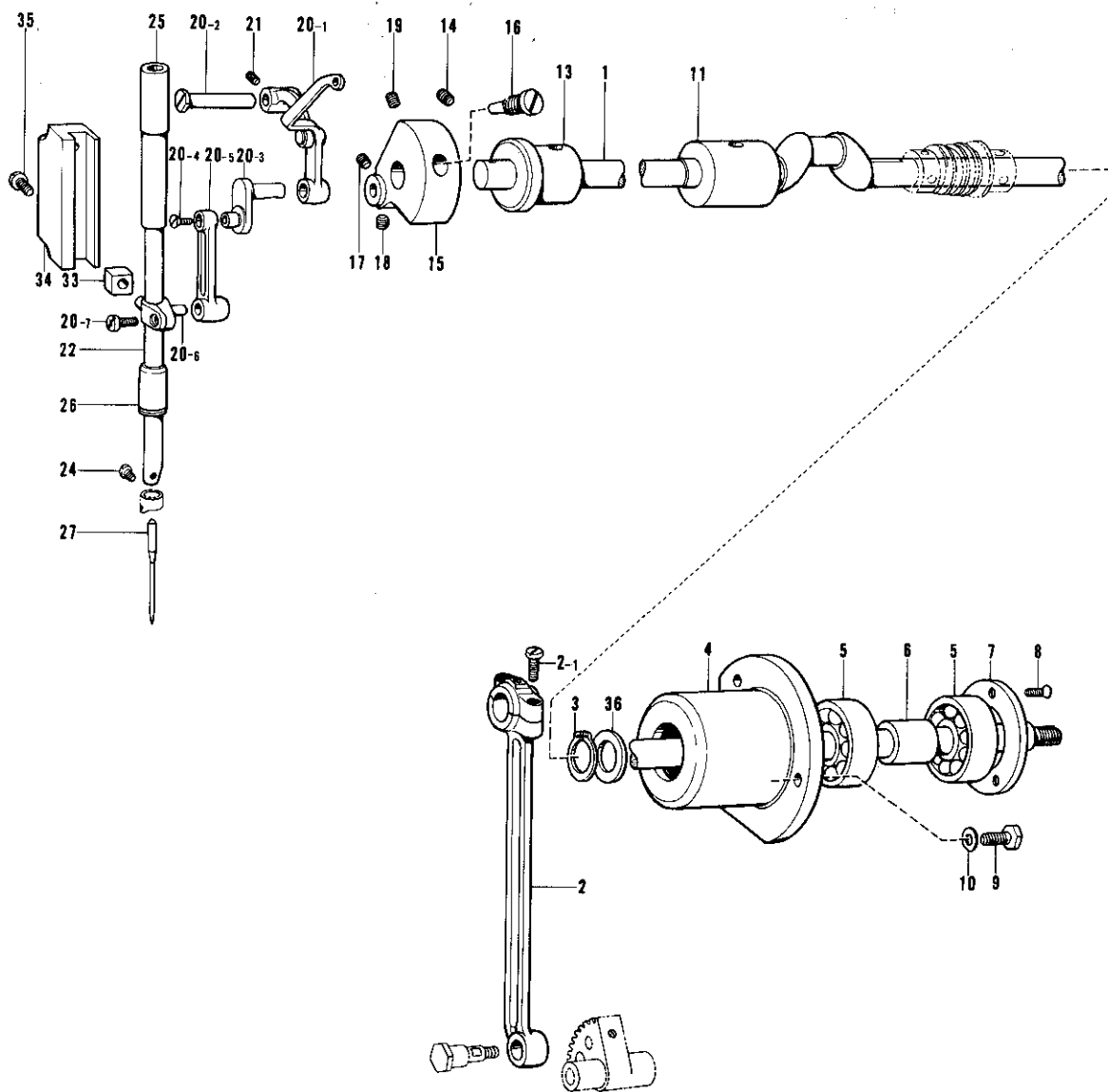

C. 上軸・針棒関係/Upper shaft and needle bar mechanism/Obere Welle und Nadelstange/
 Mécanisme de arbre supérieur et barre à aiguille/Mecanismo de carreta de potencia

REF.NO.	CODE	Q'TY	ヒンメイ	NAME OF PARTS	RMKS
1	151995001	1	ウワジ"ク	UPPER SHAFT	
2	153040001	1	クランクロッド"クミ	CRANK ROD ASSEMBLY	
2-1	144712002	2	シメネジ"4.76	SCREW 4.76	
3	048150142	1	トメワジ"クヨウC15	STOP RING C15	
4	151997000	1	タマシ"クウケケース	BALL BEARING CASE	
5	072630260	2	ハ"アリング"6302VV	BEARING 6302VV	
6	151998000	1	ハ"アリング"カンザ"	BEARING COLLAR	
7	151999001	1	タマシ"クウケフタ	BEARING CAP	
8	102843004	3	サラネジ"3.57	SCREW 3.57	
9	017761412	3	ボ"ルト5.95X14	BOLT 5.95X14	
10	025060232	3	ヒラサ"カ"ネチユウ6	WASHER 6	
11	140726000	1	ウワジ"クメタルM	UPPER SHAFT BUSHING (M)	
13	152000001	1	ウワジ"クメタルF	UPPER SHAFT BUSHING (F)	
14	013761412	1	トメネジ"5.95クホ"ミ	SCREW 5.95	
15	154623000	1	ツリアイクランクB	COUNTER WEIGHT B	
16	100250001	1	シメネジ"7.14	SCREW 7.14	
17	014770622	1	アナトメネジ"6.35クホ"ミ	SCREW 6.35	
18	123006001	1	トメネジ"6.35クホ"ミ	SCREW 6.35	
19	014770622	1	アナトメネジ"6.35クホ"ミ	SCREW 6.35	
20	154561001	1	ハリホ"ウレンカクミ	THREAD TAKE-UP LEVER ASSEMBLY	
20-1	153330001	1	テンビ"ンクミ	THREAD TAKE-UP ASSEMBLY	
20-2	152236001	1	テンビ"ンササエシ"ク	THREAD TAKE-UP LEVER SUPPORTER STUD	
20-3	154624001	1	ハリホ"ウクランクB	NEEDLE BAR CRANK B	
20-4	100253001	1	サラネジ"3.57L	SCREW 3.57L	
20-5	152238001	1	ハリホ"ウレンカン	NEEDLE BAR CONNECTOR	
20-6	152239001	1	ハリホ"ウタ"キ	NEEDLE BAR CLAMP	
20-7	062680812	1	ナヘ"コ437-40X8	SCREW 437-40X8	
21	013761412	1	トメネジ"5.95クホ"ミ	SCREW 5.95	
22	154701001	1	ハリホ"ウD	NEEDLE BAR D	
24	144458001	1	アタマツキトメネジ"3.57	SCREW 3.57	
25	152242001	1	ハリホ"ウメタルU	NEEDLE BAR BUSHING (U)	
26	154627001	1	ハリホ"ウメタルDS	NEEDLE BAR BUSHING (DS)	
27	115053016	1	ミシンハリTQX1#16	NEEDLE TQX1 #16	
33	142211001	1	カクコマ	SLIDE BLOCK	
34	152244000	1	ハリホ"ウアンナイ	NEEDLE BAR GUIDE	
35	062781412	2	ナヘ"コ635-28X14	SCREW 635-28X14	
36	116920001	1	オクリシ"クスラストリング"	THRUST RING	

D. パワー押工関係 / Power lift mechanism / Heberbetätigungsverrichtung /
 Mécanisme de leueur / Mecanismo de carreta de potencia

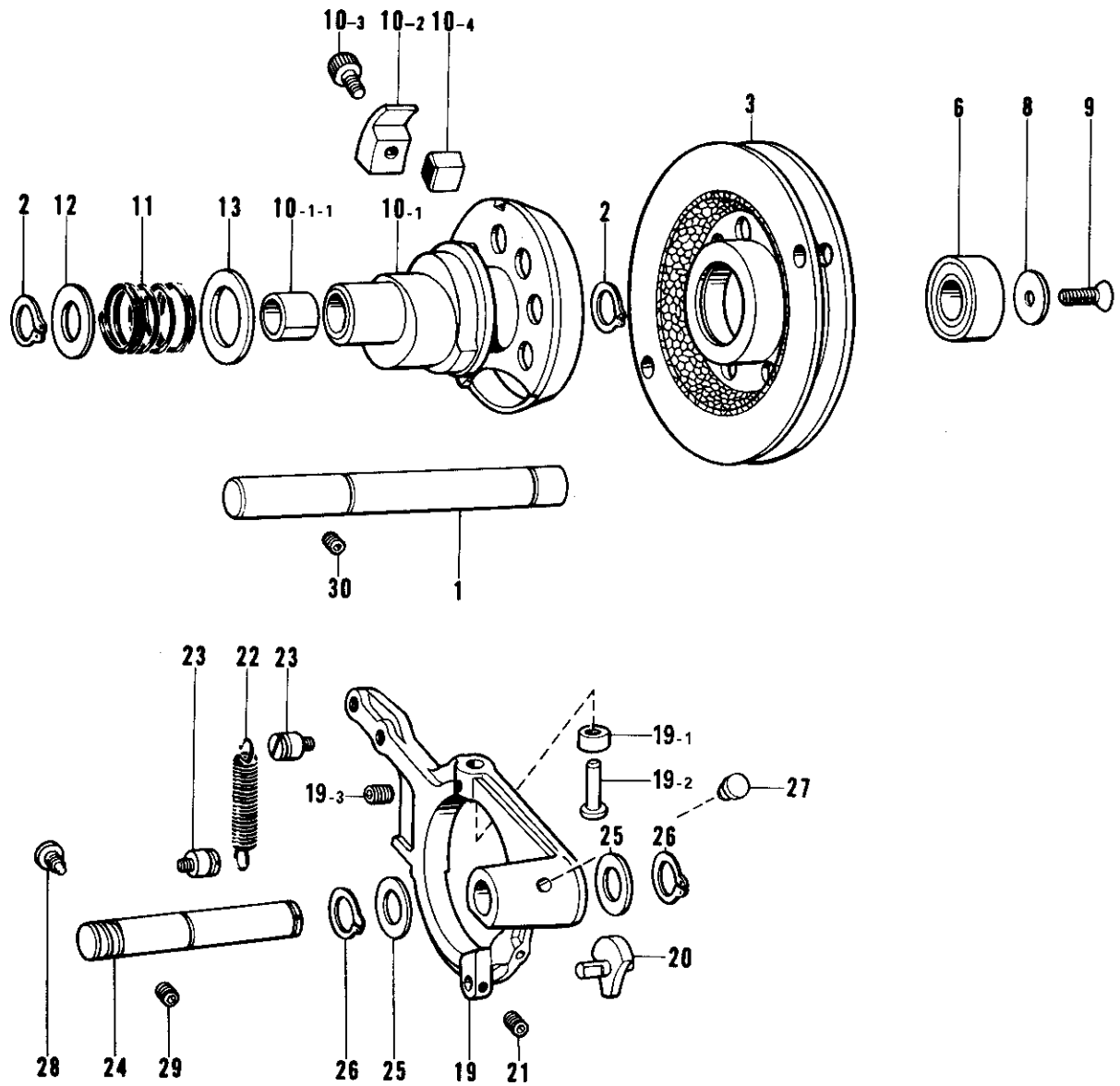

D. パワー押工関係/Power lift mechanism/Heberbetätigungsverrichtung/
Mécanisme de leueur/Mecanismo de carreta de potencia

REF.NO.	CODE	Q'TY	ヒンメイ	NAME OF PARTS	RMKS
1	151928001	1	Pプーリシク	POWER PULLEY SHAFT	
2	048170142	2	トメワシクヨウC17	STOP RING C17	
3	151930201	1	Pプーリクミ	POWER PULLEY ASSEMBLY	
6	072600360	1	タマシクウケ6003VV	BEARING 6003VV	
8	151932001	1	シクウケフタ	BEARING COVER	
9	107231002	1	サラネシ4.76	SCREW 4.76	
10	155523001	1	ハワーカムセット	POWER CAM SET	
10-1	151933001	1	ハワーカムクミ	POWER CAM ASSEMBLY	
10-1-1	151935000	2	DVフツツシユ	DV BUSHING	
10-2	151940001	1	ハワーカムストツハ [°] A	POWER CAM STOPPER A	
10-3	018060822	1	アナボルト6X8	BOLT 6X8	
10-4	151941101	1	ハワーカムストツハ [°] Bクミ	POWER CAM STOPPER B ASSEMBLY	
11	151936001	1	Pクラッチハネ	POWER CLUTCH SPRING	
12	151937001	1	スラストサカネ17	THRUST WASHER 17	
13	151938001	1	サカネ	WASHER	
19	151944001	1	クトレハークミ	CLUTCH ACTUATING LEVER ASSEMBLY	
19-1	151947101	2	コロ11	ROLLER 11	
19-2	151948001	2	クトレハークロシク	ROLLER STUD	
19-3	014760622	2	アナトメネシ5.95クホ [°] ミ	SCREW 5.95	
20	151949001	1	オサエアケコロシククミ	ROLLER STUD ASSEMBLY	
21	014760622	1	アナトメネシ5.95クホ [°] ミ	SCREW 5.95	
22	151951001	1	クトレハークヒキハネ	SPRING	
23	141472002	2	シタイトキリレハハネカケ	SPRING HOOK	
24	151952001	1	クトレハーク	CLUTCH ACTUATING LEVER SHAFT	
25	151953001	2	スラストサカネ16	THRUST WASHER 16	
26	048160142	2	トメワシクヨウC16	STOP RING C16	
27	111865001	1	オイルメクラセン	CAP FOR OIL INLET	
28	151954001	1	アンナイヒンネシ	SCREW	
29	014821022	1	アナトメネシ7.94クホ [°] ミ	SCREW 7.94	
30	014760622	1	アナトメネシ5.95クホ [°] ミ	SCREW 5.95	

E. 送り関係 / Feed mechanism / Transportvorrichtung /
 Mécanisme de l'entraînement / Mecanismo de la alimentación

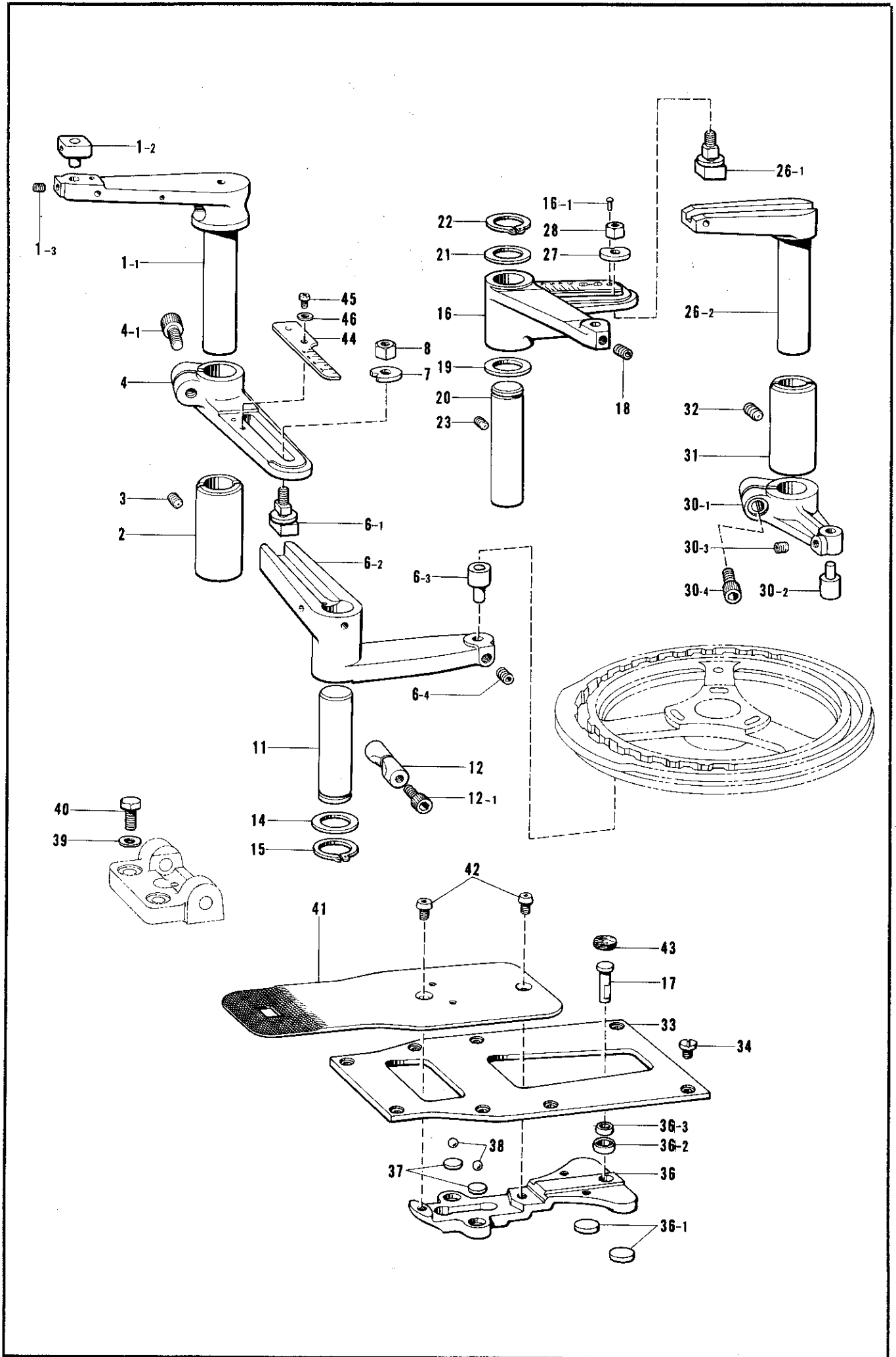

E. 送り関係/Feed mechanism/Transportvorrichtung/
Mécanisme de l'entraînement/Mecanismo de la alimentación

REF.NO.	CODE	Q'TY	ヒンメイ	NAME OF PARTS	RMKS
1-1	152742001	1	ヨコオクリレハ"	TACK LENGTH LEVER	
1-2	153041001	1	ヨコオクリカクコ"マクミ	TACK LENGTH SLIDE BLOCK ASSEMBLY	
1-3	151602002	1	トメネシ"4.37	SCREW 4.37	
2	152745001	1	オクリメタル	BUSHING	
3	014760622	1	アナトメネシ"5.95クホ"ミ	SCREW 5.95	
4	153820101	1	ヨコチヨウセツレハ"ークミ	TACK LENGTH REGULATOR LEVER ASSEMBLY	
4-1	018082022	1	アナホ"ルト8X20	BOLT 8X20	
6-1	153042001	1	オクリチヨウセツシ"ククミ	TACK REGULATOR SHAFT ASSEMBLY	
6-2	152752001	1	ヨコオクリカムレハ"	TACK LENGTH LEVER	
6-3	153988001	1	オクリカムコロシ"ククミA	FEED CAM ROLLER A ASSEMBLY	
6-4	014760622	1	アナトメネシ"5.95クホ"ミ	SCREW 5.95	
7	152749001	1	オクリチヨウセツサ"カ"ネ	WASHER	
8	152750001	1	オクリチヨウセツナツ	NUT	
11	152755001	1	ヨコオクリカムレハ"ーシ"ク	TACK LENGTH LEVER SHAFT	
12	S09132001	1	ヒンチスリーブ"クミ	SLEEVE ASSEMBLY	
12-1	018063022	1	アナホ"ルト6X30	BOLT 6X30	
14	152756001	1	スラストサ"カ"ネ18	THRUST WASHER 18	
15	048180142	1	トメワC18	STOP RING C18	
16	154174001	1	タテオクリレハ"ークミ	TACK WIDTH LEVER ASSEMBLY	
16-1	116231001	2	トメピン	PIN	
17	152759001	1	タテオクリシ"ク	TACK WIDTH SHAFT	
18	014760622	1	アナトメネシ"5.95クホ"ミ	SCREW 5.95	
19	152756001	1	スラストサ"カ"ネ18	THRUST WASHER 18	
20	152760001	1	タテオクリレハ"ーシ"ク	TACK WIDTH LEVER SHAFT	
21	152756001	1	スラストサ"カ"ネ18	THRUST WASHER 18	
22	048180142	1	トメワC18	STOP RING C18	
23	014760622	1	アナトメネシ"5.95クホ"ミ	SCREW 5.95	
26-1	153042001	1	オクリチヨウセツシ"ククミ	TACK REGULATOR SHAFT ASSEMBLY	
26-2	153823001	1	タテオクリチヨウセツレハ"	TACK WIDTH REGULATOR LEVER	
27	152749001	1	オクリチヨウセツサ"カ"ネ	WASHER	
28	152750001	1	オクリチヨウセツナツ	NUT	
30-1	153824001	1	タテオクリカムレハ"	TACK WIDTH FEED LEVER	
30-2	153989001	1	オクリカムコロシ"ククミB	FEED CAM ROLLAR (B) ASSEMBLY	
30-3	014760622	1	アナトメネシ"5.95クホ"ミ	SCREW 5.95	
30-4	018082022	1	アナホ"ルト8X20	BOLT 8X20	
31	152745001	1	オクリメタル	BUSHING	
32	014760622	1	アナトメネシ"5.95クホ"ミ	SCREW 5.95	
33	152766001	1	オクリタ"イアンナイタ	FEED GUIDE PLATE	
34	145318001	8	シメネシ"4.37	SCREW 4.37	
36	152769001	1	オクリタ"イクミ	FEED GUIDE ASSEMBLY	
36-1	152771000	2	オクリタ"イカンサ"	WASHER	
36-2	152773001	1	キユウメンブ"ツシユメタル	BUSHING	
36-3	141331001	1	キユウメンブ"シユ	BUSHING	
37	152772001	2	カンサ"	WASHER	
38	071047650	2	コウキユウ3/16	STEEL BALL 3/16	
39	025060232	2	ヒラサ"カ"ネチユウ6	WASHER 6	
40	017761212	2	ホ"ルト5.95X12	BOLT 5.95X12	
41	159971001	1	オクリイタ11ヒラ	FEED PLATE FLAT11	
42	153057002	2	オクリイタシメネシ"	FEED PLATE SCREW	
43	153035000	1	オサエウテ"フェルト	PRESSER ARM FELT	
44	153826001	1	ヨコオクリメモリイタ	TACK LENGTH INDICATOR	
45	060660512	1	ハ"イント"318-40X5	SCREW 318-40X5	
46	025030132	1	ヒラサ"カ"ネシユウ3	WASHER 3	

F. 押工上げ関係 / Work clamp lifter mechanism / Stoffhalterhebevorrichtung /
 Mécanisme de levier du pinceur / Mecanismo de levantador de ménsula de trabajo

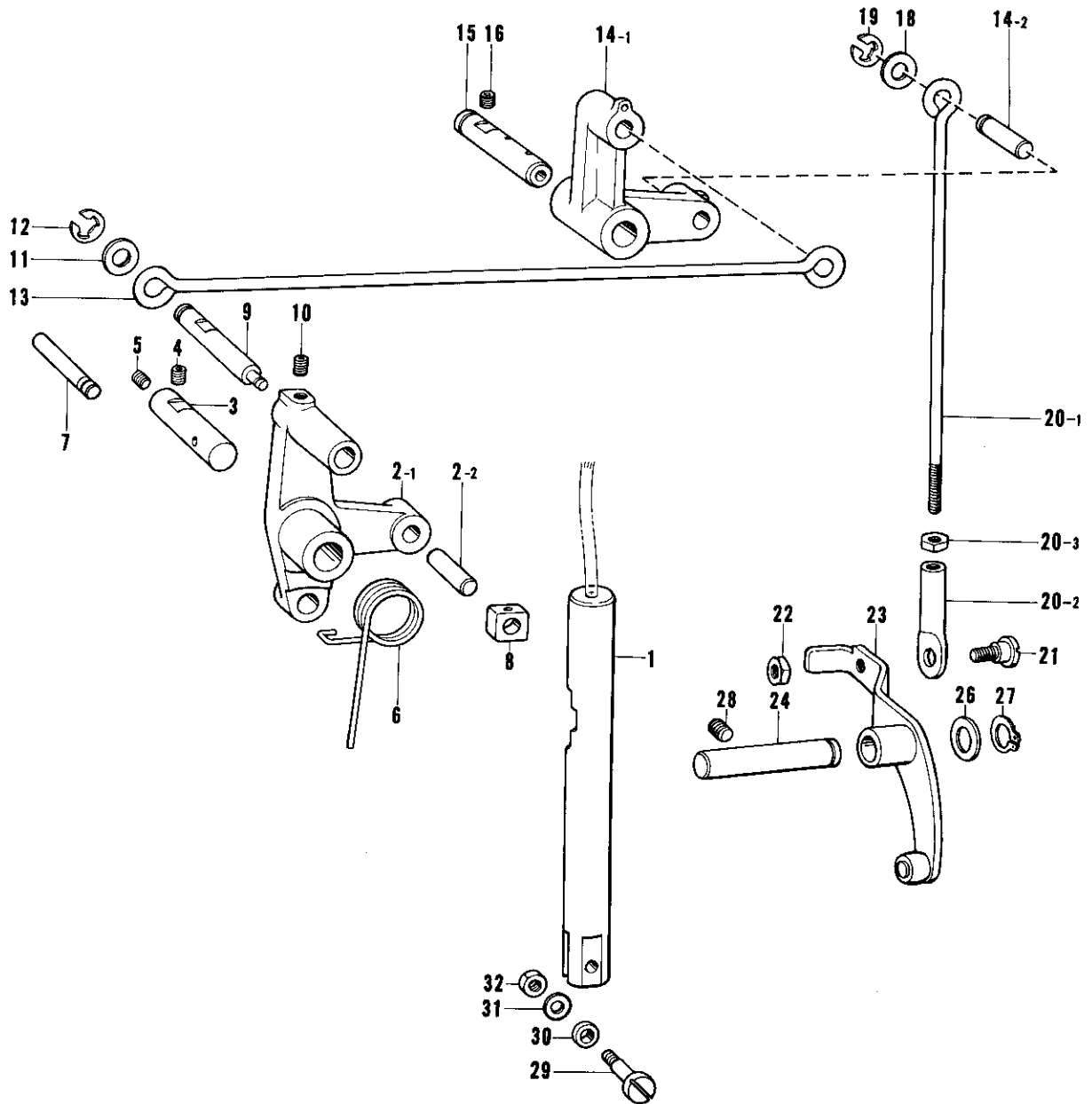

F. 押工上げ関係/Work clamp lifter mechanism/Stoffhalterhebevorrichtung/
Mécánisme de leueur du pinceur/Mecanismo de levantador de ménsula de trabajo

REF.NO.	CODE	Q'TY	ヒンメイ	NAME OF PARTS	RMKS
1	153831001	1	オサエアケ"ロツト"	WORK CLAMP LIFTING ROD	
2-1	152798001	1	オサエアケ"レハ"	WORK CLAMP LIFTER LEVER	
2-2	152744001	1	ヨコオクリカクゴ"マヒン	TACK LENGTH SLIDE BLOCK PIN	
3	152799001	1	オサエアケ"レハ"ーシ"ク	WORK CLAMP LIFTER LEVER SHAFT	
4	014760622	1	アナトメネシ"5.95クホ"ミ	SCREW 5.95	
5	013760612	1	トメネシ"5.95クホ"ミ	SCREW 5.95	
6	152800201	1	オサエアケ"ハ"ネ	SPRING	
7	152801001	1	ハ"ネカケヒン	PIN	
8	102630001	1	ハリホ"ウアンナイカクコマ	NEEDLE BAR GUIDE SLIDE BLOCK	
9	152802001	1	オサエアケ"ロツト"シ"クA	WORK CLAMP LIFTER ROD SHAFT A	
10	014760622	1	アナトメネシ"5.95クホ"ミ	SCREW 5.95	
11	107153002	1	サ"カ"ネ	WASHER	
12	048060342	1	トメフE6	STOP RING E6	
13	152803001	1	オサエアケ"ロツト"A	WORK CLAMP LIFTER ROD A	
14-1	152805101	1	オサエアケ"レンケツレハ"ー	CONNECTING LEVER	
14-2	152806001	2	オサエアケ"ロツト"シ"クB	CONNECTING LEVER SHAFT B	
15	158686001	1	レンケツレハ"ーシ"ク	LIFTING LEVER SHAFT	
16	014760622	1	アナトメネシ"5.95クホ"ミ	SCREW 5.95	
18	107153002	2	サ"カ"ネ	WASHER	
19	048060342	2	トメフE6	STOP RING E6	
20	152808101	1	チヨウセツロツト"クミ	CONNECTING ROD ASSEMBLY	
20-1	154332001	1	オサエアケ"チヨウセツロツト"	CONNECTING ROD	
20-2	154333001	1	オサエアケ"チヨウセツツキ"テ	CONNECTING JOINT	
20-3	150556001	1	ナツト6.35	NUT 6.35	
21	141583001	1	タ"ンネシ"6.35	STUD SCREW 6.35	
22	150556001	1	ナツト6.35	NUT 6.35	
23	152811001	1	サト"ウレハ"ークミ	CONNECTING LEVER ASSEMBLY	
24	158687001	1	サト"ウレハ"ーシ"ク	DRIVING SHAFT	
26	142628001	1	スイハイオクリクランクリング"	HORIZONTAL FEED CRANK RING	
27	048110142	1	トメフジ"クヨウC11	STOP RING C11	
28	014760622	1	アナトメネシ"5.95クホ"ミ	SCREW 5.95	
29	153828001	1	コロジ"ク	ROLLER STUD	
30	107744001	1	コロ	ROLLER	
31	153484001	1	サ"カ"ネ4.76	WASHER 4.76	
32	105234003	2	ナツト4.37	NUT 4.37	

G. ボタンツマミ作動関係 / Button clamp mechanism / Knopfhaltevorrichtung /
 Mécanisme du pince-bowtons / Mecanismo de la ménsula de resorte

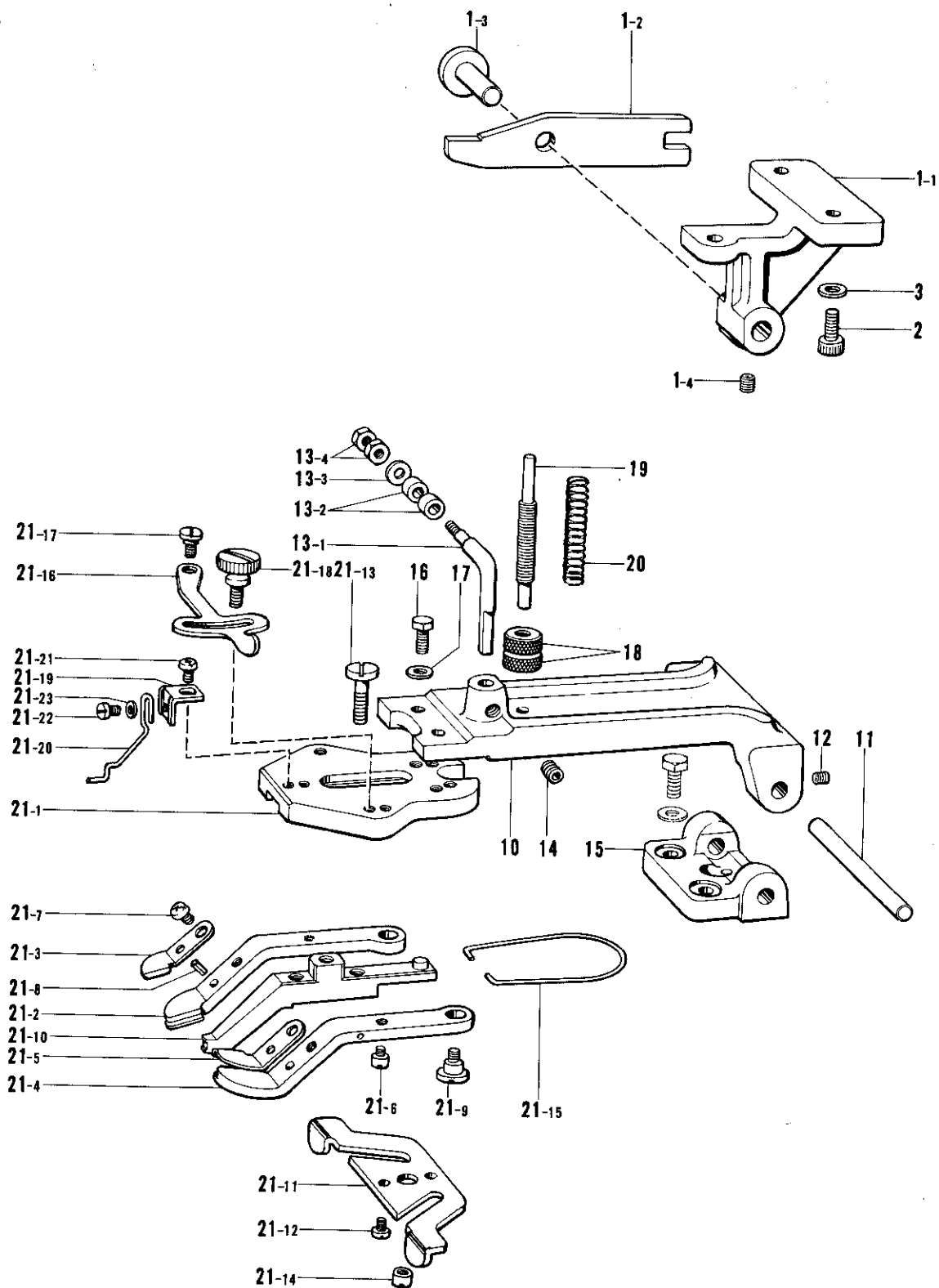

G. ボタンツマミ作動関係/ Button clamp mechanism/ Knopfhaltevorrichtung/
 Mécanisme du pince-bowtons/ Mecanismo de la ménsula de resorte

REF.NO.	CODE	Q'TY	ヒンメイ	NAME OF PARTS	RMKS
1-1	153835006	1	レハ"ホルダー	LEVER HOLDER BRACKET	
1-2	153836101	1	ホ"タンツカミアケ"レハ"	BUTTON CLAMP LIFTING LEVER	
1-3	153838001	1	ホ"タンツカミレハ"ーシ"ク	BUTTON CLAMP LEVER SHAFT	
1-4	014760622	1	アナトメネシ"5.95クホ"ミ	SCREW 5.95	
2	018062022	2	アナホル"ルト6X20	BOLT 6X20	
3	025060232	2	ヒラサ"ガ"ネチユウ6	WASHER 6	
10	153830006	1	ホ"タンツカミホルダ"	BUTTON CLAMP HOLDER	
11	153827001	1	ホ"タンツカミホルダ"ーシ"ク	BUTTON CLAMP HOLDER SHAFT	
12	014680622	2	アナトメネシ"4.37クホ"ミ	SCREW 4.37	
13	151968001	1	ホ"タンホルダ"ーフツククミ	BUTTON CLAMP HOLDER HOOK ASSEMBLY	
13-1	151969001	1	ホ"タンホルダ"ーフツク	BUTTON CLAMP HOLDER HOOK	
13-2	107744001	2	コロ	ROLLER	
13-3	153484001	1	サ"ガ"ネ4.76	WASHER 4.76	
13-4	105234003	2	ナツト4.37	NUT 4.37	
14	014760622	1	アナトメネシ"5.95クホ"ミ	SCREW 5.95	
15	153834001	1	ホ"タンツカミホルダ"ーササエ	BUTTON CLAMP HOLDER BRACKET	
16	017711412	2	ホル"ルト4.76X14	BOLT 4.76X14	
17	146354001	2	サ"ガ"ネ	WASHER	
18	146994001	2	オサエハ"ネチヨウシネシ"	PRESSER SPRING ADJUSTING SCREW	
19	115148101	1	オサエハ"ネチヨウセツネシ"	PRESSER SPRING ADJUSTING SCREW	
20	115147001	1	ホ"タンツカミオサエオシハ"ネ	BUTTON CLAMP PRESSER SPRING	
21	156107201	1	ホ"タンツカミCクミ	BUTTON CLAMP C ASSEMBLY	
21-1	S03464101	1	ホ"タンツカミタイ	BUTTON CLAMP BRACKET	
21-2	S03465101	1	ホ"タンツカミL	BUTTON CLAMP (L)	
21-3	159941001	1	ホ"タンツカミLイタハ"ネ	BOTTAN CLAMP (L) PLATE SPRING	
21-4	S03466101	1	ホ"タンツカミR	BUTTON CLAMP (R)	
21-5	159942001	1	ホ"タンツカミRイタハ"ネ	BOTTAN CLAMP (R) PLATE SPRING	
21-6	115156001	2	ホ"タンツカミアンナイピン	GUIDE PIN	
21-7	062680512	2	ナヘ"コ437-40X5	SCREW 437-40X5	
21-8	047250642	2	スプリング"ピンAW2.5	SPRING PIN AW2.5	
21-9	115158001	2	ダンネシ"4.76	STUD SCREW 4.76	
21-10	S03467001	1	ホ"タンツカミMクミ	BUTTON CLAMP M ASSEMBLY	
21-11	S03659001	1	ホ"タンツカミイタカム	BUTTON CLAMP PLATE	
21-12	062680812	2	ナヘ"コ437-40X8	SCREW 437-40X8	
21-13	S03468001	1	シメネシ"4.37	SCREW 4.37	
21-14	S03657001	1	マルナツト4.37	NUT 4.37	
21-15	115163001	1	ホ"タンツカミイタハ"ネ	BUTTON CLAMP SPRING PLATE	
21-16	115164001	1	ホ"タンツカミチヨウセツイタ	BUTTON CLAMP ADJUSTING PLATE	
21-17	115165001	1	ダンネシ"4.37	STUD SCREW 4.37	
21-18	115166001	1	ダンネシ"4.37	STUD SCREW 4.37	
21-19	159938001	1	ホ"タンウカシハ"ネササエ	SPRING STOPPER	
21-20	159939001	1	ホ"タンウカシハ"ネA	SPRING A	
21-21	062710612	1	ナヘ"コ476-32X6	SCREW 476-32X6	
21-22	110215002	1	シメネシ"3.57	SCREW 3.57	
21-23	025660132	1	ヒラサ"ガ"ネシヨウ3.18	WASHER 3.18	

H. カム伝導関係 / Feed cam mechanism / Vertikale Welle /
 Mécanisme d'arbre vertical / Mecanismo de eje vertical

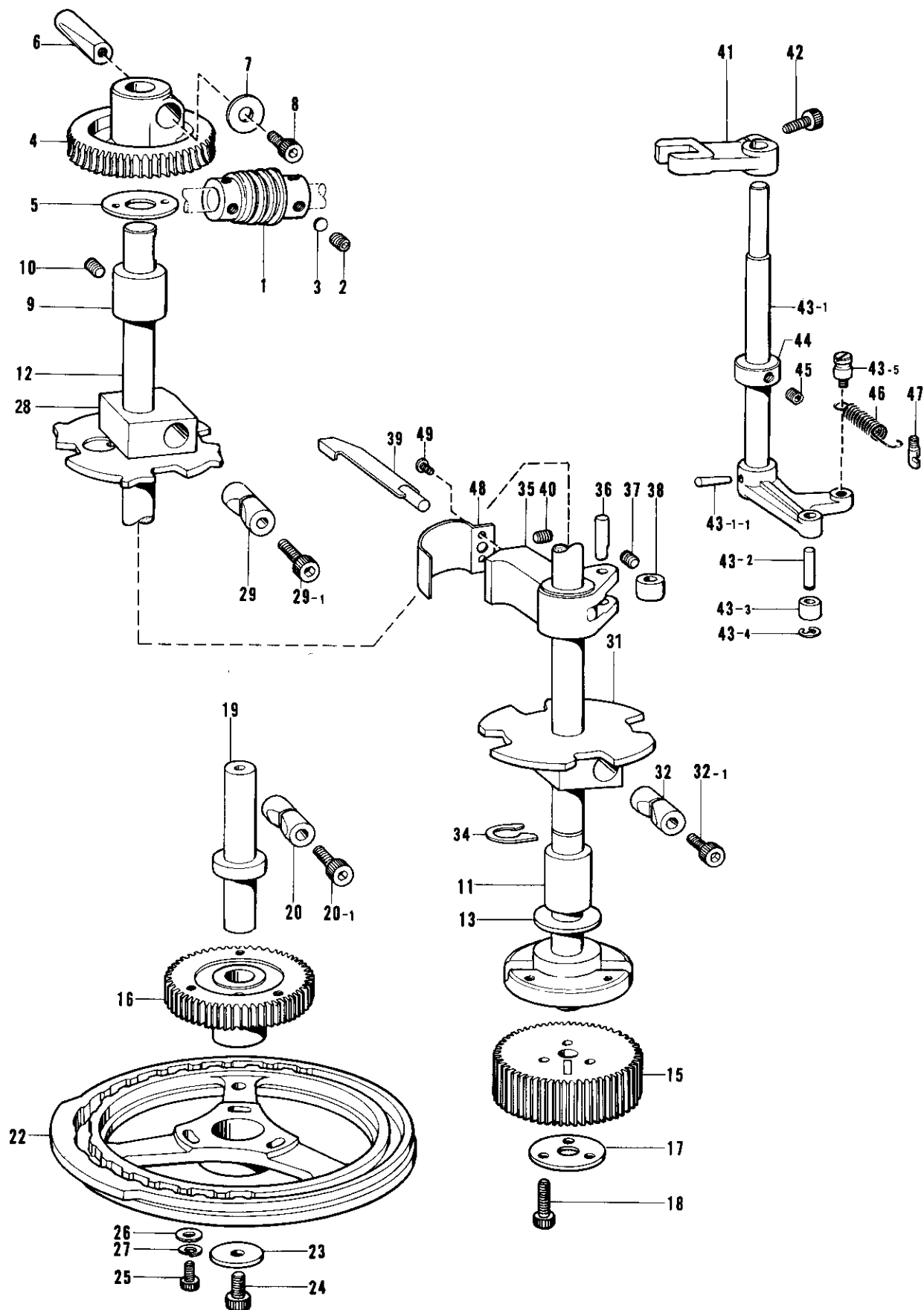

H. カム伝導関係/Feed cam mechanism/Vertikale Welle/
Mécánisme d'arbre vertical/Mecanismo de eje vertical

REF.NO.	CODE	Q'TY	ヒンメイ	NAME OF PARTS	RMKS
1	*	1	ウオーム	WORM	
2	152718001	6	アナトメネジ"5.95	SCREW 5.95	
3	147151000	1	トメサ"カ"ネ	WASHER	
4	*	1	ウオームホイール	WORM WHEEL	
5	152713001	1	スラストサ"カ"ネ	THRUST WASHER	
6	152709000	1	スリーブ"	SLEEVE	
7	152710001	1	サ"カ"ネ	WASHER	
8	018062022	1	アナホ"ルト6X20	BOLT 6X20	
9	159977000	1	タテシ"クメタルU	VERTICAL SHAFT BUSHING (U)	
10	014760622	1	アナトメネジ"5.95クホ"ミ	SCREW 5.95	
11	159978001	1	タテシ"クメタルL	VERTICAL SHAFT BUSHING (L)	
12	159979001	1	タテシ"クソウクミ	VERTICAL SHAFT ASSEMBLY	
13	159984001	1	スラストサ"カ"ネ40	THRUST WASHER 40	
15	152719000	1	チェンシ"キ"ヤ28W	CHANGE GEAR 28W	
16	152720000	1	チェンシ"キ"ヤ28C	CHANGE GEAR 28C	
17	153104001	1	チェンシ"キ"ヤサ"カ"ネ	WASHER	
18	018062222	3	アナホ"ルト6X22	BOLT 6X22	
19	152724001	1	カムシ"ク	TACK LENGTH FEED CAM SHAFT	
20	S09132001	1	ピンチスリーブ"クミ	SLEEVE ASSEMBLY	
20-1	018063022	1	アナホ"ルト6X30	BOLT 6X30	
22	*	1	オクリカム	FEED CAM	
23	152728001	1	スラストサ"カ"ネ8	THRUST WASHER 8	
24	151163001	1	アナホ"ルト8X15	BOLT 8X15	
25	018062022	3	アナホ"ルト6X20	BOLT 6X20	
26	109893002	3	サ"カ"ネ	WASHER	
27	028060242	3	ハ"ネサ"カ"ネ2-6	SPRING WASHER 2-6	
28	*	1	クラツチカム	CLUTCH CAM	
29	S09132001	1	ピンチスリーブ"クミ	SLEEVE ASSEMBLY	
29-1	018063022	1	アナホ"ルト6X30	BOLT 6X30	
31	*	1	イトキリカム	KNIFE CAM	
32	S09132001	1	ピンチスリーブ"クミ	SLEEVE ASSEMBLY	
32-1	018063022	1	アナホ"ルト6X30	BOLT 6X30	
34	152723001	1	イトキリカムトメリング"	STOP RING	
35	152731001	1	セイキ"ヨタイ	ROLLER HOLDER	
36	152732001	1	セイキ"ヨタイコロシ"ク	SHAFT	
37	013710712	1	トメネジ"4.76クホ"ミ	SCREW 4.76	
38	152914001	1	コロ	ROLLER	
39	153845001	1	ハリカス"キリカエレハ"ー	STITCH CONTROL LEVER	
40	013710712	1	トメネジ"4.76クホ"ミ	SCREW 4.76	
41	152734001	1	セイキ"ヨレハ"ー	ROLLER HOLDER LEVER	
42	018061622	1	アナホ"ルト6X16	BOLT 6X16	
43	152735101	1	セイキ"ヨカムレハ"ークミ	ROLLER HOLDER CAM LEVER ASSEMBLY	
43-1	153332001	1	セイキ"ヨカムレハ"ーシ"ククミ	ROLLER HOLDER CAM LEVER SHAFT ASSEMBLY	
43-1-1	046302020	1	テーパ"ピン3X20	TAPAR PIN 3X20	
43-2	152739001	1	コロシ"ク	ROLLER STUD	
43-3	153195001	1	コロ	ROLLER	
43-4	048040342	1	トメワE4	STOP RING E4	
43-5	155337001	1	ハ"ネカケ	SPRING HOOK	
44	110027001	1	セツトカラ"ー	SET COLLAR	
45	014760622	2	アナトメネジ"5.95クホ"ミ	SCREW 5.95	
46	155336001	1	セイキ"ヨハ"ネ	SPRING	
47	141334001	1	ハ"ネカケ	SPRING HOOK	
48	153141001	1	セイキ"ヨタイカハ"ー	ROLLER HOLDER COVER	
49	062670412	2	ナヘ"コ357-40X4	SCREW 357-40X4	

J. 下軸関係 / Lower shaft mechanism / Untere Welle
 Mécanisme de l'arbre inférieur / Mecanismo de la eje inferior

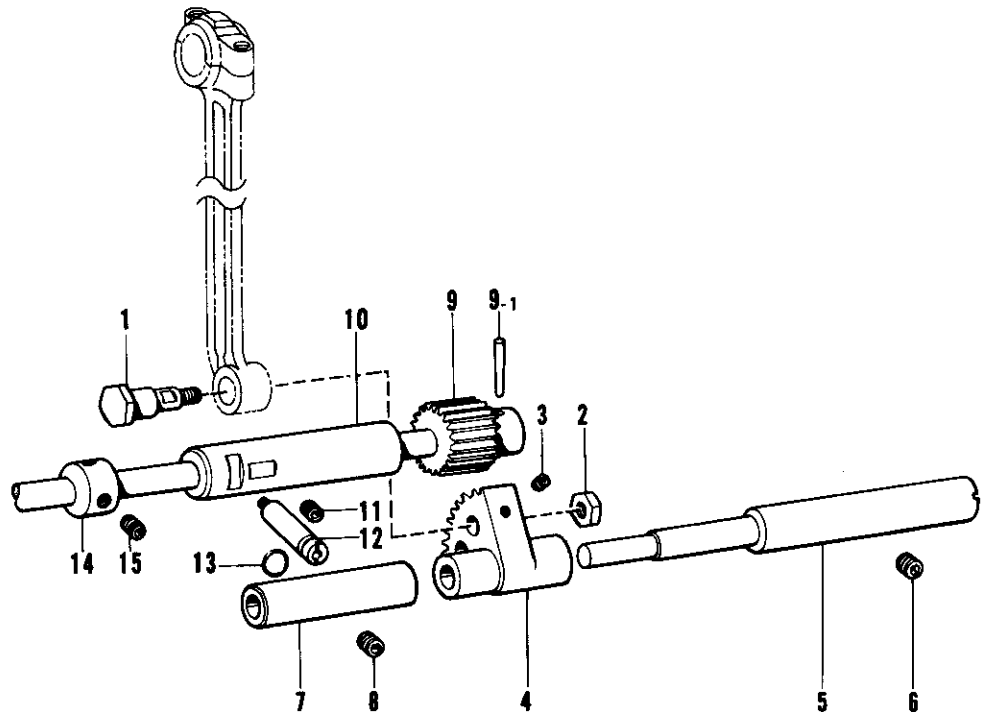
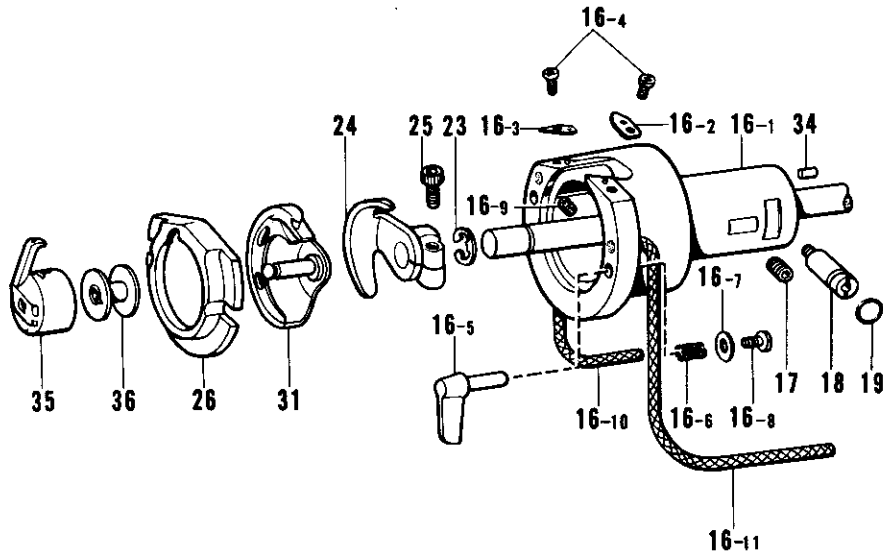

J. 下軸関係 / Lower shaft mechanism / Untere Welle
 Mécanisme de l'arbre inférieur / Mecanismo de la eje inferior

REF.NO.	CODE	Q'TY	ヒンメイ	NAME OF PARTS	RMKS
1	141786001	1	クランクロッド"タ"ンネシ"	CRANK ROD STUD SCREW	
2	104689002	1	ナット7.14	NUT 7.14	
3	014680622	1	アナトメネシ"4.37クホ"ミ	SCREW 4.37	
4	152245001	1	ヨウト"ウキ"ヤ	ROCK GEAR	
5	152246001	1	ヨウト"ウキ"ヤ-シ"ク	ROCK GEAR SHAFT	
6	014760622	1	アナトメネシ"5.95クホ"ミ	SCREW 5.95	
7	152247001	1	ヨウト"ウジ"クメタル	ROCK SHAFT BUSHING	
8	014760622	1	アナトメネシ"5.95クホ"ミ	SCREW 5.95	
9	152191001	1	シタシ"クク"ミ	LOWER SHAFT ASSEMBLY	
9-1	046301620	1	テーパ-ピン3X16	TAPER PIN 3X16	
10	152250001	1	シタシ"クメタル	LOWER SHAFT BUSHING	
11	014760622	1	アナトメネシ"5.95クホ"ミ	SCREW 5.95	
12	152678001	1	カマチヨウセツシ"ク	SHUTTLE HOOK ADJUSTING STUD	
13	081003670	1	Oリング"PW3	O RING PW3	
14	110495003	1	セツトカラー	SET COLLAR	
15	014770622	2	アナトメネシ"6.35クホ"ミ	SCREW 6.35	
16	S00327001	1	オオカマタイクミ	SHUTTLE RACE BODY ASSEMBLY	
16-1	152677001	1	オオカマタイ	SHUTTLE RACE BODY	
16-2	152679001	1	カマイトアンナイR	SHUTTLE RACE THREAD GUIDE (R)	
16-3	152680001	1	カマイトアンナイL	SHUTTLE RACE THREAD GUIDE (L)	
16-4	062660412	2	ナヘ"コ318-40X4	SCREW 318-40X4	
16-5	152683001	2	オオカマトリツケツメ	SHUTTLE RACE RING SET CLAW	
16-6	152684001	2	オオカマトリツケハ"ネ	SPRING	
16-7	402887001	2	サ"ガ"ネ3.2	WASHER 3.2	
16-8	062660712	2	ナヘ"コ318-40X7	SCREW 318-40X7	
16-9	153050000	2	オオカマタイフェルト	SHUTTLE RACE BODY FELT	
16-10	155489000	1	クミヒモ(270MM)	WICK (270MM)	
16-11	S00400000	1	クミヒモ2.5X220	WICK 2.5X220	
17	014760622	1	アナトメネシ"5.95クホ"ミ	SCREW 5.95	
18	152678001	1	カマチヨウセツシ"ク	SHUTTLE HOOK ADJUSTING STUD	
19	081003670	1	Oリング"PW3	O RING PW3	
23	048080342	1	トメフE8	STOP RING E8	
24	152681101	1	ト"ライハ"ー	DRIVER	
25	018501422	1	アナボ"ルト5X14	BOLT 5X14	
26	152682001	1	オオカマA	SHUTTLE RACE RING A	
31	152685101	1	ナカカマA	SHUTTLE HOOK A	
34	141808001	1	オオカマアンナイピン	PIN	
35	159610101	1	ホ"ビ"ンケースクミA	BOBBIN CASE A ASSEMBLY	
36	159613001	1	ホ"ビ"ン	BOBBIN	

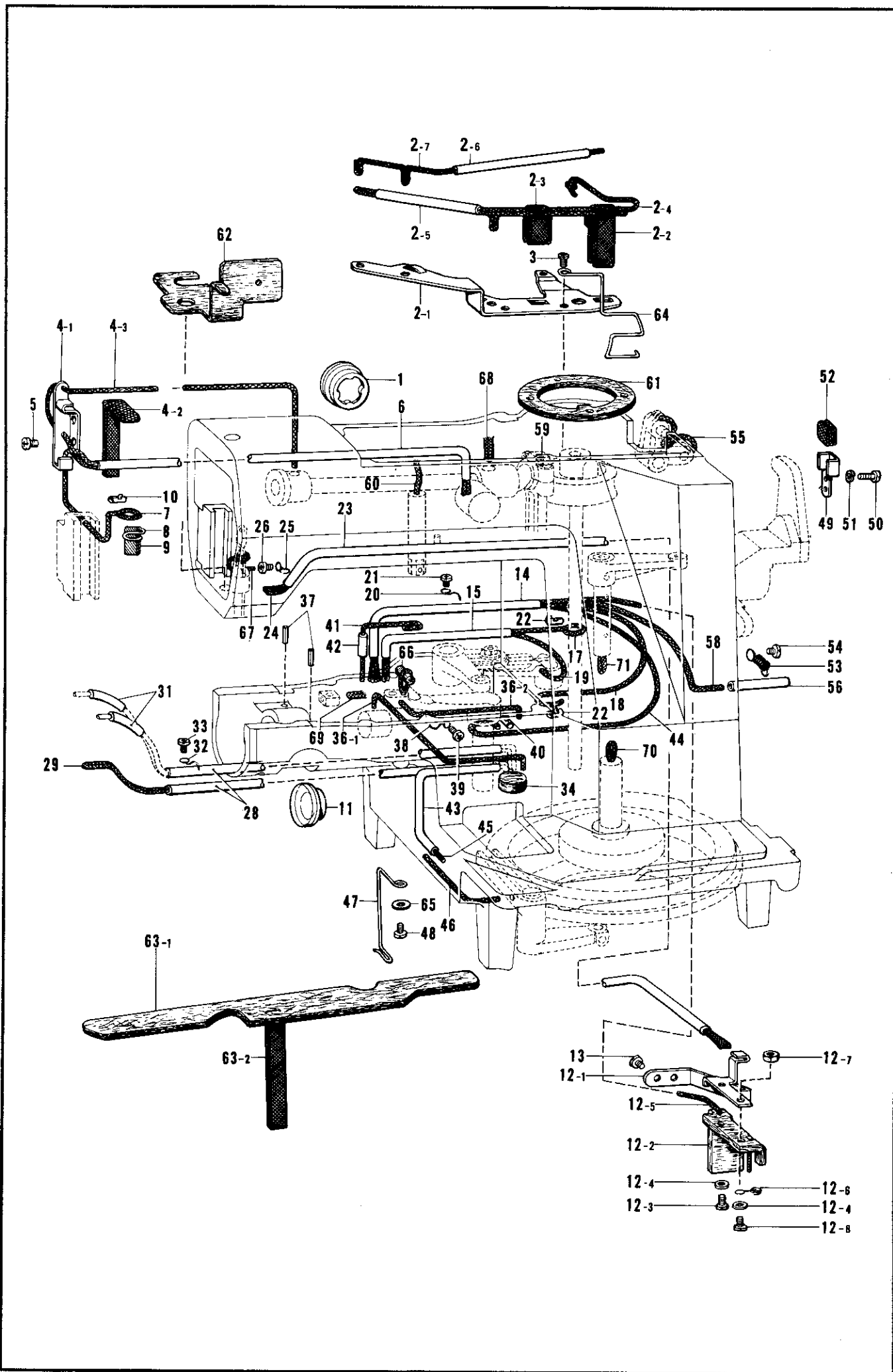

K. 給油・潤滑関係/Lubrication / Schmierung
Lubrication / Lubricación

REF.NO.	CODE	Q'TY	品名	NAME OF PARTS	RMKS
1	152948001	1	オイルホ"ツトマト"	OIL GUAGE WINDOW	
2	152949001	1	ウツシ"クキユウユササエクミ	WICK SUPPORTER ASSEMBLY	
2-1	152950001	1	ウツシ"クキユウユササエ	WICK SUPPORTER	
2-2	152951001	1	ウオームキユウユフエルト	FELT	
2-3	152952001	1	ロツト"キユウユフエルト	FELT	
2-4	153918001	1	クミヒモ6X6(660MM)	WICK 6X6 (660MM)	
2-5	140423000	1	ビ"ニルチューブ"	OIL TUBE	
2-6	147745000	1	ハイユハ"イフ" L	OIL TUBE L	
2-7	153919001	1	クミヒモ6X6(370MM)	WICK 6X6 (370MM)	
3	062681012	2	ナヘ"ゴ437-40X10	SCREW 437-40X10	
4	152958001	1	テンヒ"ンキユウユササエクミ	WICK SUPPORTER ASSEMBLY	
4-1	152959001	1	テンヒ"ンキユウユササエ	WICK SUPPORTER	
4-2	152955001	1	ヒラクミヒモ(160MM)	WICK (160MM)	
4-3	152956001	1	クミヒモ4X4(1000MM)	WICK 4X4 (1000MM)	
5	062680612	1	ナヘ"ゴ437-40X6	SCREW 437-40X6	
6	144694001	1	ハイユハ"イフ"	OIL TUBE	
7	152956001	1	クミヒモ4X4(500MM)	WICK 4X4 (500MM)	
8	152962001	1	ハリホ"ウメタルヒモササエ	WICK SUPPORTER	
9	152960001	1	ヒラクミヒモ(65MM)	WICK (65MM)	
10	104567001	1	クミヒモササエ	WICK SUPPORTER	
11	152948001	1	オイルホ"ツトマト"	OIL GUAGE WINDOW	
12	152961001	1	シタシ"クキユウユササエクミ	FELT SUPPORTER ASSEMBLY	
12-1	152966001	1	シタシ"クキユウユササエ	FELT SUPPORTER	
12-2	152967001	1	シタシ"クキユウユフエルト	FELT	
12-3	062670812	2	ナヘ"ゴ357-40X8	SCREW 357-40X8	
12-4	025350332	3	ヒラサ"ガ"ネタ"イ3.5	WASHER 3.5	
12-5	152963001	1	クミヒモ4X4	WICK 4X4	
12-6	141692001	1	ビ"ニルチューブ"ササエC	TUBE STOPPER C	
12-7	021670202	1	ナツト2シユ3.57	NUT 3.57	
12-8	062671412	1	ナヘ"ゴ357-40X14	SCREW 357-40X14	
13	062670612	2	ナヘ"ゴ357-40X6	SCREW 357-40X6	
14	148921000	1	ビ"ニルチューブ"	OIL TUBE	
15	147745000	1	ハイユハ"イフ" L	OIL TUBE L	
17	152964001	1	クミヒモ6X6(620MM)	WICK 6X6 (620MM)	
18	152965001	1	クミヒモ4X4(400MM)	WICK 4X4 (400MM)	
19	152964001	1	クミヒモ6X6(310MM)	WICK 6X6 (310MM)	
20	152969001	1	コード"ササエカネ	CORD SUPPORTER	
21	062670512	1	ナヘ"ゴ357-40X5	SCREW 357-40X5	
22	104567001	2	クミヒモササエ	WICK SUPPORTER	
23	146375000	1	ビ"ニルチューブ"	OIL TUBE	
24	152992001	1	ヒラクミヒモ(820MM)	WICK (820MM)	
25	117150001	1	コード"ササエカネ	CORD SUPPORTER	
26	062670512	1	ナヘ"ゴ357-40X5	SCREW 357-40X5	
28	140423000	2	ビ"ニルチューブ"	OIL TUBE	
29	152971001	1	クミヒモ4X4	WICK 4X4	
31	112669001	2	ビ"ニルチューブ"	VINYL TUBE	
32	152969001	1	コード"ササエカネ	CORD SUPPORTER	
33	062670512	1	ナヘ"ゴ357-40X5	SCREW 357-40X5	
34	113006001	1	フェルト	FELT	
36-1	152973001	1	クミヒモ4X4(160MM)	WICK 4X4 (160MM)	
36-2	153921001	1	クミヒモ4X4(180MM)	WICK 4X4 (180MM)	
37	047251640	2	スプリング"ヒンAW2.5	SPRING PIN AW2.5	
38	117150001	1	コード"ササエカネ	CORD SUPPORTER	
39	062670512	1	ナヘ"ゴ357-40X5	SCREW 357-40X5	
40	104567001	1	クミヒモササエ	WICK SUPPORTER	
41	152974001	1	クミヒモ4X4(250MM)	WICK 4X4 (250MM)	
42	112669001	1	ビ"ニルチューブ"	VINYL TUBE	
43	147745000	1	ハイユハ"イフ" L	OIL TUBE L	
44	153922001	1	クミヒモ4X4(340MM)	WICK 4X4 (340MM)	
45	152953001	1	クミヒモ6X6(360MM)	WICK 6X6 (360MM)	
46	152985001	1	クミヒモ4X4(750MM)	WICK 4X4 (750MM)	
47	153763001	1	キユウユヒモササエ	WICK SUPPORTER	

K. 給油・潤滑関係/Lubrication / Schmierung
 Lubrification / Lubricación

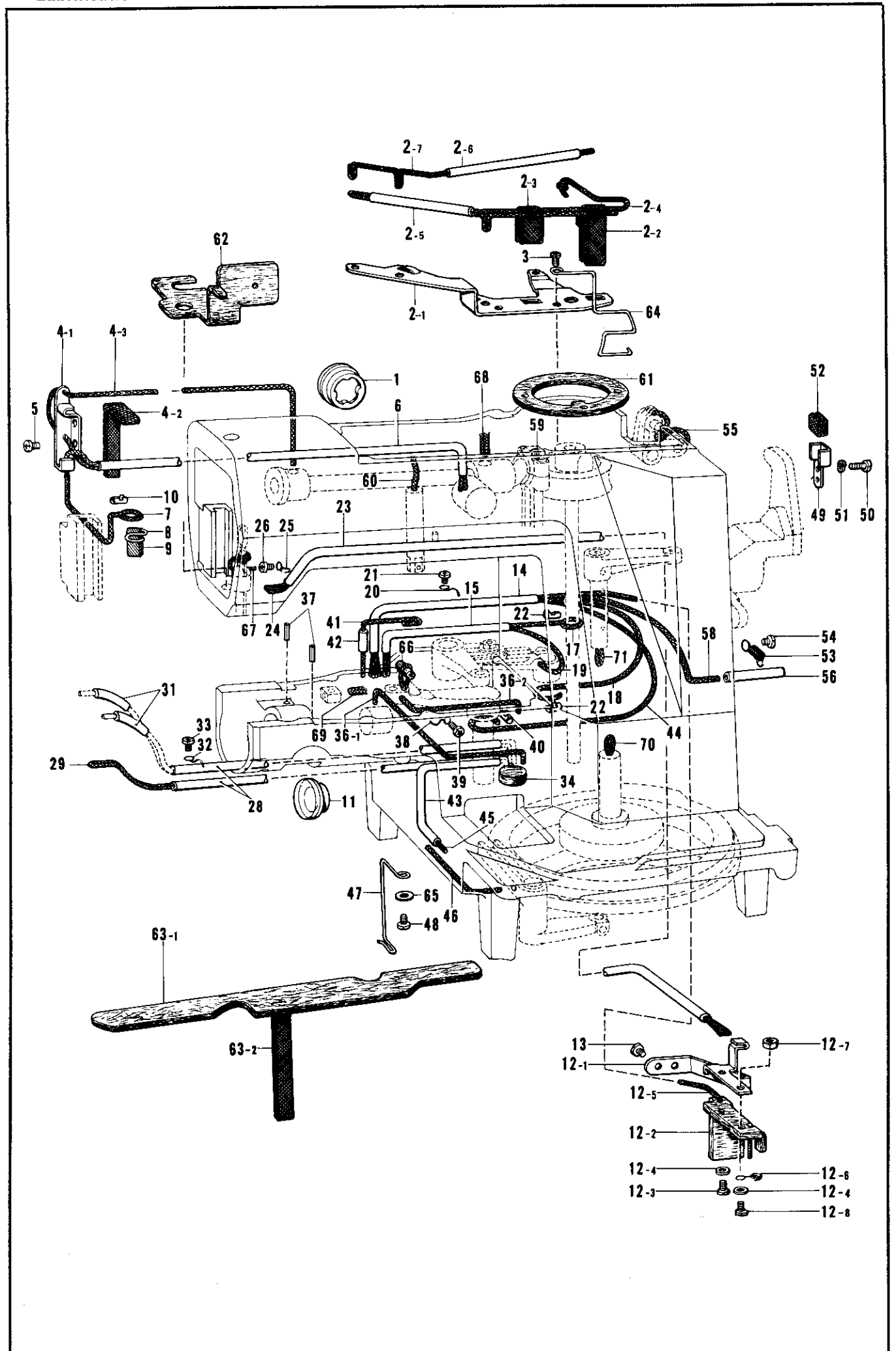

K. 給油・潤滑関係 / Lubrication / Schmierung
Lubrication / Lubricación

REF.NO.	CODE	Q'TY	品名	NAME OF PARTS	RMKS
48	062670512	1	ナヘ"コ357-40X5	SCREW 357-40X5	
49	152976001	1	ホ"ールキユウヒモササエ	WICK HOLDER	
50	062670512	2	ナヘ"コ357-40X5	SCREW 357-40X5	
51	028040242	2	ハ"ネサ"カ"ネ2-4	SPRING WASHER2-4	
52	152977001	1	ヒラクミヒモ(50MM)	WICK (50MM)	
53	152978001	1	チューブ"オサエ	TUBE SUPPORTER	
54	062680812	1	ナヘ"コ437-40X8	SCREW 437-40X8	
55	153927001	1	クミヒモ6X6	WICK 6X6	
56	112669001	1	ビ"ニルチューブ"	VINYL TUBE	
58	153922001	1	クミヒモ4X4(500MM)	WICK 4X4 (500MM)	
59	107149001	1	フェルト	FELT	
60	152968001	1	クミヒモ4X4(100MM)	WICK 4X4 (100MM)	
61	153529001	1	ホ"ールキユウフエルト	FELT	
62	153530001	1	スイアケ"フェルト	FELT	
63-1	153531001	1	ハ"ット"Lフェルト	FELT	
63-2	153562001	1	ヒラクミヒモ(220MM)	WICK (220MM)	
64	153528001	1	ウ"ームキユウフエルトササエ	FELT SUPPORTER	
65	105248003	1	サ"カ"ネ	WASHER	
66	153924001	1	フェルト	FELT	
67	152973001	1	クミヒモ4X4(180MM)	WICK 4X4 (180MM)	
68	153925001	1	クミヒモ4X4(30MM)	WICK 4X4 (30MM)	
69	153926001	1	タコヒモ(10MM)	WICK (10MM)	
70	152980001	1	クミヒモ6X6(150MM)	WICK 6X6 (150MM)	
71	152980001	1	クミヒモ6X6(140MM)	WICK 6X6 (140MM)	

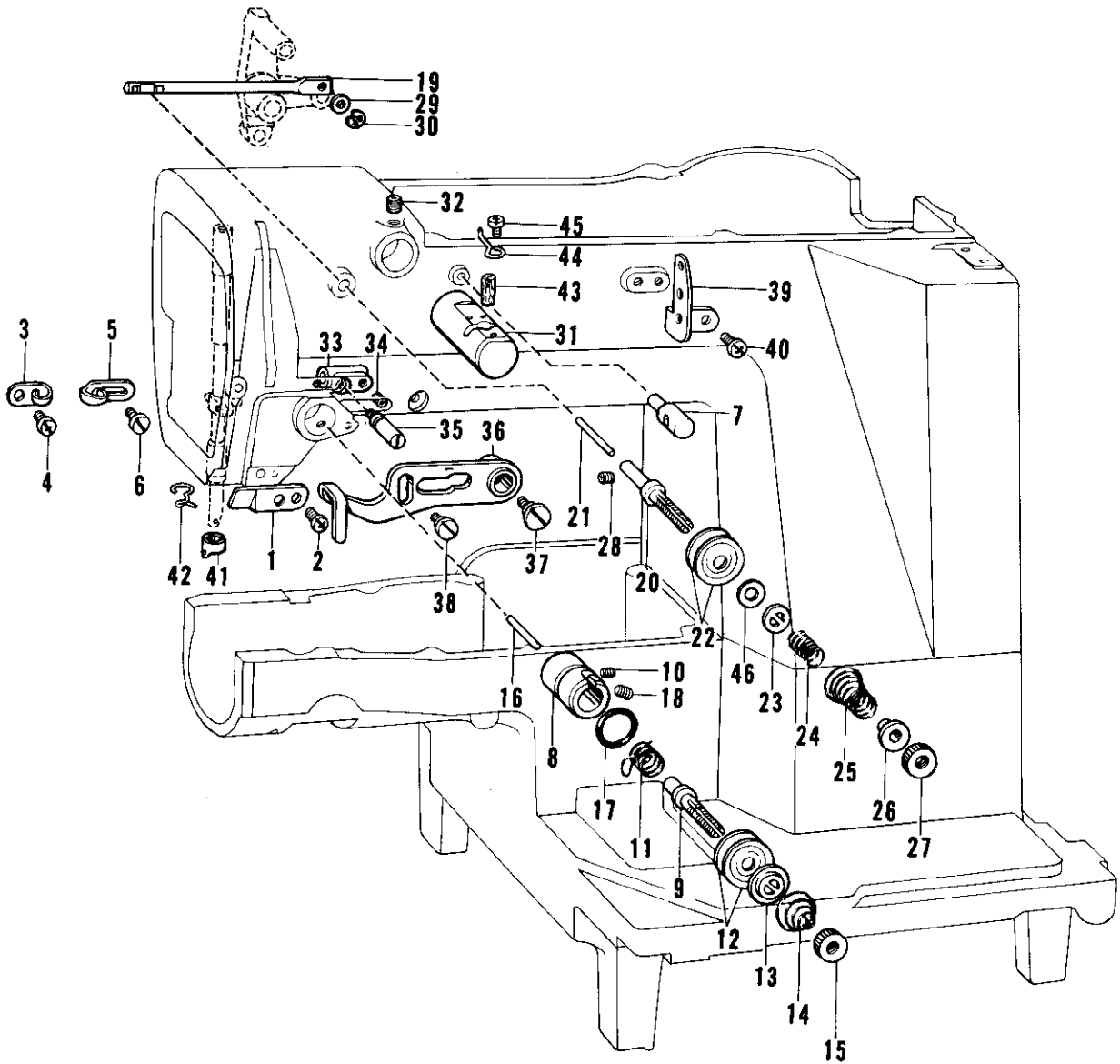

L. 糸通シ関係 / Threading mechanism / Fadenführungsrichtung
 Mécanisme de l'enfilage / Mecanismo de la enhebrado

REF.NO.	CODE	Q'TY	ヒンメイ	NAME OF PARTS	RMKS
1	152869001	1	アームイトミチ	ARM THREAD GUIDE	
2	062710712	1	ナヘ"コ476-32X7	SCREW 476-32X7	
3	152870001	1	アームイトカケ	ARM THREAD GUIDE	
4	062670612	1	ナヘ"コ357-40X6	SCREW 357-40X6	
5	113316001	1	アームイトアンナイ	ARM THREAD GUIDE	
6	112751003	1	シメネシ"3.57	SCREW 3.57	
7	153049001	1	ウワイトアンナイホ"ウ	UPPER THREAD GUIDE BAR	
8	152872001	1	イトチヨウシダ"イ	TENSION BRACKET	
9	100398001	1	イトチヨウシホ"ウ	TENSION STUD	
10	100402004	1	トメネシ"3.57	SCREW 3.57	
11	145519001	1	イトトリハ"ネ	THREAD TAKE-UP SPRING	
12	145446001	2	イトチヨウシサラ	TENSION DISC	
13	159805001	1	イトチヨウシサラオサエ	TENSION DISC WASHER	
14	107606001	1	イトチヨウシハ"ネ	TENSION SPRING	
15	100136001	1	イトチヨウシナツト	TENSION CONTROL NUT	
16	152873001	1	イトユルメヒ"ン	TENSION RELEASE PIN	
17	114294001	1	Oリング"	O RING	
18	103950003	1	トメネシ"5.95	SCREW 5.95	
19	152874001	1	フクイトユルメホ"ウ	SUB TENSION RELEASE BAR	
20	152875001	1	フクイトチヨウシホ"ウ	SUB TENSION CONTROL STUD	
21	152876001	1	フクイトユルメヒ"ン	SUB TENSION RELEASE PIN	
22	145446001	2	イトチヨウシサラ	TENSION DISC	
23	152877001	1	イトチヨウシサラオサエ	TENSION DISC WASHER	
24	152878001	1	ウワイトオサエハ"ネ	TENSION SPRING	
25	152879101	1	フクチヨウシハ"ネ	SUB TENSION SPRING	
26	152880001	1	ハ"ネウケ	SPRING HOLDER	
27	100136001	1	イトチヨウシナツト	TENSION CONTROL NUT	
28	014680422	1	アナトメネシ"4.37クホ"ミ	SCREW 4.37	
29	140208001	1	サ"カ"ネ	WASHER	
30	048040342	1	トメフE4	STOP RING E4	
31	152881001	1	エキレイタイクミ	NEEDLE COOLER BODY	
32	013760612	1	トメネシ"5.95クホ"ミ	SCREW 5.95	
33	152886001	1	イトトリアンナイシ"クウケ	THREAD TAKE-UP GUIDE	
34	014680422	1	アナトメネシ"4.37クホ"ミ	SCREW 4.37	
35	152887001	1	イトトリアンナイシ"ク	THREAD TAKE-UP LEVER GUIDE STUD	
36	152888101	1	イトトリレハ"ー	THREAD TAKE-UP LEVER	
37	141528001	1	タ"ンネシ"6.35	STUD SCREW 6.35	
38	115077003	1	タ"ンネシ"4.76	STUD SCREW 4.76	
39	152889001	1	ミツメイトカケ	THREAD RETAINER	
40	062670612	2	ナヘ"コ357-40X6	SCREW 357-40X6	
41	152890001	1	ハリホ"ウイトアンナイA	NEEDLE BAR THREAD GUIDE A	
42	154626001	1	ハリホ"ウメタルDイトアンナイ	NEEDLE BAR BUSHING D THREAD GUIDE	
43	152883000	1	フェルト8X15.5	FELT 8X15.5	
44	152884001	1	エキレイイトカケ	NEEDLE COOLER THREAD GUIDE	
45	062670412	1	ナヘ"コ357-40X4	SCREW 357-40X4	
46	153138001	1	サ"カ"ネ	WASHER	

M. 糸巻キ関係/Bobbin winder mechanism/Spuler
 Mécanisme de bobineur/Mecanismo del devanador de la canilla

REF.NO.	CODE	Q'TY	ヒンメイ	NAME OF PARTS	RMKS
1	152982101	1	イトマキクミ	BOBBIN WINDER ASSEMBLY	
1-1	152983001	1	イトマキタイ	BOBBIN WINDER BRACKET	
1-2	152984001	1	イトマキレハ	BOBBIN WINDER LEVER	
1-3	152933001	1	イトマキシク	BOBBIN WINDER SHAFT	
1-4	152934001	1	イトマキレハ	BOBBIN WINDER LEVER SHAFT	
1-5	102716004	1	トメネシ4.37	SCREW 4.37	
1-6	152935001	1	ホ"ヒンオサエ	BOBBIN PRESSER	
1-7	152936001	1	イタハ"ネ	PLATE SPRING	
1-8	152937001	1	サ"カ"ネ	WASHER	
1-9	062670712	1	ナヘ"コ357-40X7	SCREW 357-40X7	
1-10	152938001	1	メス	KNIFE	
1-11	062680712	1	ナヘ"コ437-40X7	SCREW 437-40X7	
1-12	152939001	1	イトマキレハ	SPRING	
1-13	115138001	1	レハ"ヒキハ"ネカケ	SPRING HOOK	
1-14	141550001	1	テイシレハ"ハ"ネカケ	SPRING HOOK	
1-15	152940001	1	イトマキツメシク	CLAW STUD FOR BOBBIN WINDER	
1-16	142566001	1	イトマキツメ	CLAW FOR BOBBIN WINDER	
1-17	048050342	2	トメフE5	STOP RING E5	
1-18	014680422	2	アナトメネシ4.37クホ"ミ	SCREW 4.37	
1-19	062670712	1	ナヘ"コ357-40X7	SCREW 357-40X7	
1-20	152941001	1	イトマキツメネシ"リハ"ネ	SPRING	
1-21-1	154528001	1	イトマキクルマ	BOBBIN WINDER WHEEL	
1-21-2	120448001	1	ゴムフ	RUBBER RING	
1-22	102716004	2	トメネシ4.37	SCREW 4.37	
2	062761412	2	ナヘ"コ595-28X14	SCREW 595-28X14	
3	S01300001	1	シタイトチヨウシクミ	LOWER THREAD TENSION ASSEMBLY	
3-1	152945001	1	シタイトチヨウシクミ	LOWER THREAD TENSION BRACKET ASSEMBLY	
3-2	145446001	2	イトチヨウシサラ	TENSION DISC	
3-3	104525001	1	イトチヨウシハ"ネ	TENSION SPRING	
3-4	108265001	1	イトチヨウシナツト	TENSION CONTROL NUT	
7	062681012	2	ナヘ"コ437-40X10	SCREW 437-40X10	

N. 糸切り関係 / Thread trimmer mechanism / Fadenabschneidevorrichtung
 Mécanisme de coupe-fil / Mecanismo de recortadora de orillos

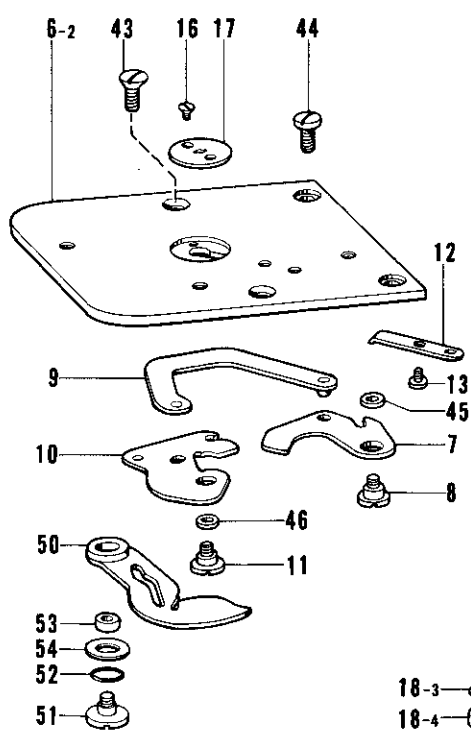

輸出用 / for Export

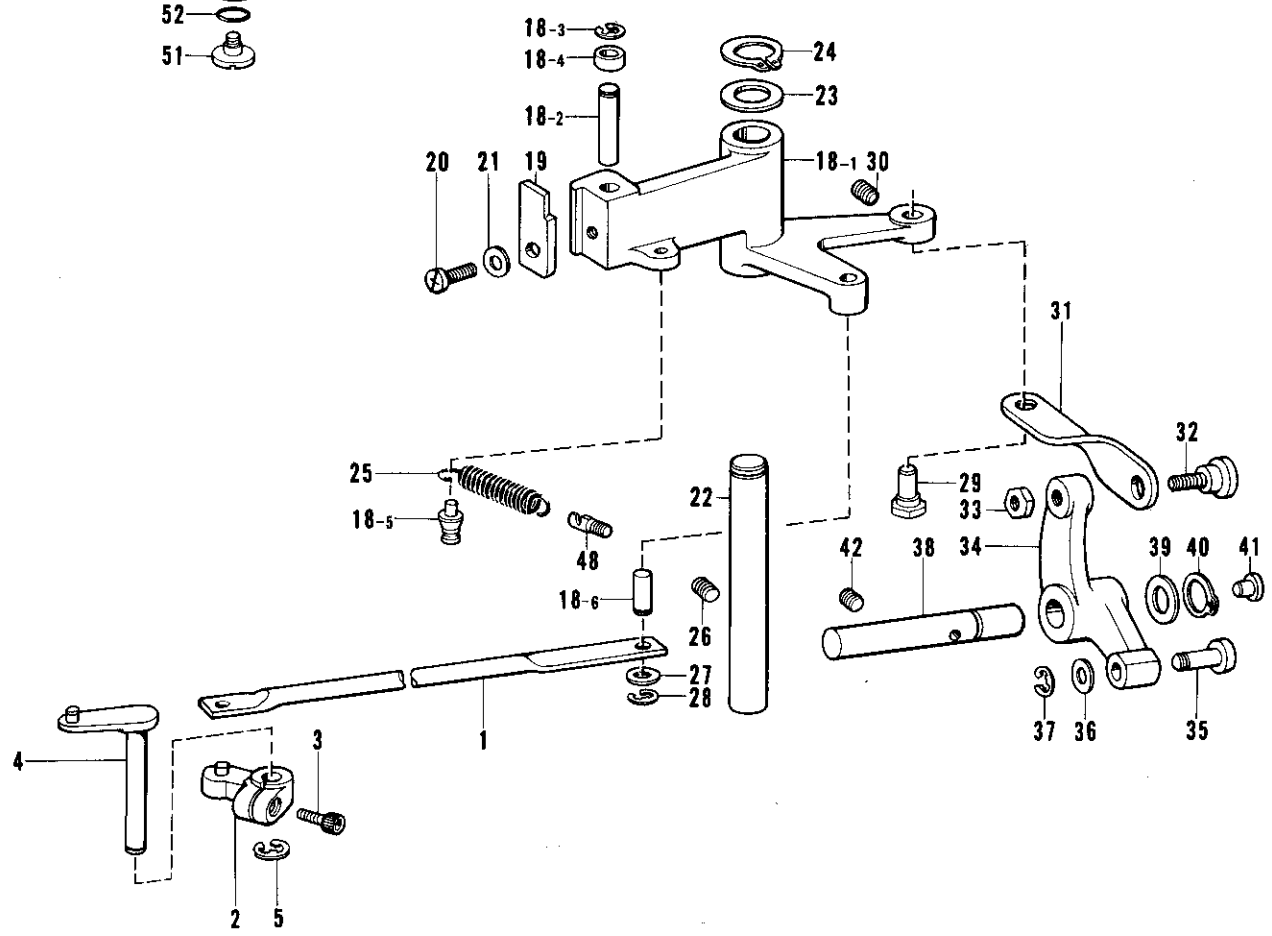
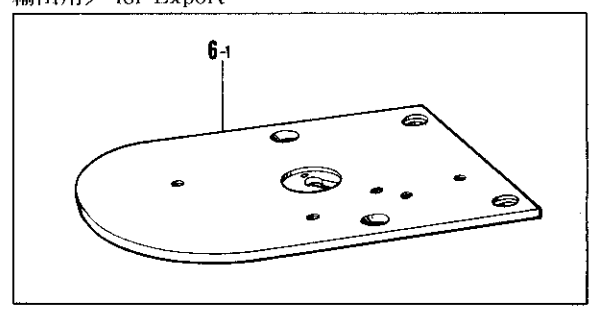

N. 糸切り関係/Thread trimmer mechanism/Fadenabschneidevorrichtung
 Mécanisme de coupe-fil/Mecanismo de recortdora de orillos

REF.NO.	CODE	Q'TY	ヒンメイ	NAME OF PARTS	RMKS
1	152892001	1	イトキリレンケツロツト	THREAD TRIMMING CONNECTING ROD	
2	152896001	1	イトキリウデ"Aクミ	THREAD TRIMMING ARM A ASSEMBLY	
3	018681022	1	アナホ"ルト4.37X10	BOLT 4.37X10	
4	152893101	1	イトキリウデ"B	THREAD TRIMMING ARM B	
5	048050342	1	トメフE5	STOP RING E5	
6-1	152995001	1	-----	NEEDLE PLATE S	
6-2	S01887001	1	ハリイタC	-----	
7	152981001	1	イトキリウデ"C	KNIFE ARM C	
8	153222001	1	シメネジ"4.37	SCREW 4.37	
9	152897201	1	イトキリレンカクミ	KNIFE CONNECTING ROD ASSEMBLY	
10	152901001	1	イト"ウハクミ	MOVABLE KNIFE ASSEMBLY	
11	152904001	1	シメネジ"4.37	SCREW 4.37	
12	152905001	1	コテイハ	FIXED KNIFE	
13	111140002	2	シメネジ"2.38	SCREW 2.38	
16	100360003	2	サラネジ"2.38	SCREW 2.38	
17	159940001	1	ハリアナイタH	NEEDLE HOLE PLATE H	
18-1	152912001	1	イトキリカムレハ"	THREAD TRIMMING CAM LEVER	
18-2	152913001	1	コロシ"ク	ROLLER STUD	
18-3	048040342	1	トメフE4	STOP RING E4	
18-4	152914001	1	コロ	ROLLER	
18-5	154789001	1	ハ"ネカケ	SPRING HOOK	
18-6	152919001	1	イトキリロツト"ピン	PIN	
19	152915001	1	イトキリカムレハ"ツメ	THREAD TRIMMING CAM LEVER CLAW	
20	062761412	1	ナヘ"コ595-28X14	SCREW 595-28X14	
21	025060132	1	ヒラサ"ガ"ネシヨウ6	WASHER 6	
22	152916001	1	イトキリカムレハ"ーシ"ク	THREAD TRIMMING CAM LEVER SHAFT	
23	152917001	1	サ"ガ"ネ	WASHER	
24	048120142	1	トメフシ"クヨウC12	STOP RING C12	
25	154788001	1	イトキリカムレハ"ーハ"ネ	KNIFE CAM LEVER SPRING	
26	014760622	1	アナトメネジ"5.95クホ"ミ	SCREW 5.95	
27	140208001	1	サ"ガ"ネ	WASHER	
28	048040342	1	トメフE4	STOP RING E4	
29	152920001	1	イトキリリンクチヨウセツシ"ク	STUD	
30	014760622	1	アナトメネジ"5.95クホ"ミ	SCREW 5.95	
31	152921001	1	イトキリリンク	THREAD TRIMMING LINK	
32	151907001	1	タ"ンネジ"5.95	STUD SCREW 5.95	
33	150553001	1	ナツト5.95	NUT 5.95	
34	152922001	1	イトキリサト"ーレハ"ー	THREAD TRIMMING LEVER	
35	152923001	1	イトキリサト"ーレハ"ーコロ	THREAD TRIMMING ROLLER	
36	112468001	1	サ"ガ"ネ	WASHER	
37	048050342	1	トメフE5	STOP RING E5	
38	153482001	1	イトキリサト"ーレハ"ーシ"ク	DRIVING SHAFT	
39	142628001	1	スイヘイオクリクランクリング	HORIZONTAL FEED CRANK RING	
40	048110142	1	トメフシ"クヨウC11	STOP RING C11	
41	111865001	1	オイルメクラセン	CAP FOR OIL INLET	
42	014760622	1	アナトメネジ"5.95クホ"ミ	SCREW 5.95	
43	100032004	2	サラネジ"4.37	SCREW 4.37	
44	153208002	2	シメネジ"4.37	SCREW 4.37	
45	153220001	1	イトキリウデ"Cカラー	KNIFE ARM C COLLAR	
46	153219001	1	イト"ウハカラー	MOVABLE KNIFE COLLAR	
48	141334001	1	ハ"ネカケ	SPRING HOOK	
50	152906101	1	シタイトサハ"キA	THREAD RETAINER A	
51	153598001	1	シメネジ"4.37	SCREW 4.37	
52	081008070	1	Oリング"P8	O RING P8	
53	153597001	1	シタイトサハ"キカラー	THREAD RETAINER COLLAR	
54	153596001	1	サ"ガ"ネ	WASHER	

P. 糸払い関係 / Thread wiper mechanism / Fadenwischvorrichtung
 Mécanisme de tire-fil / Mecanismo de limpiador de hilos

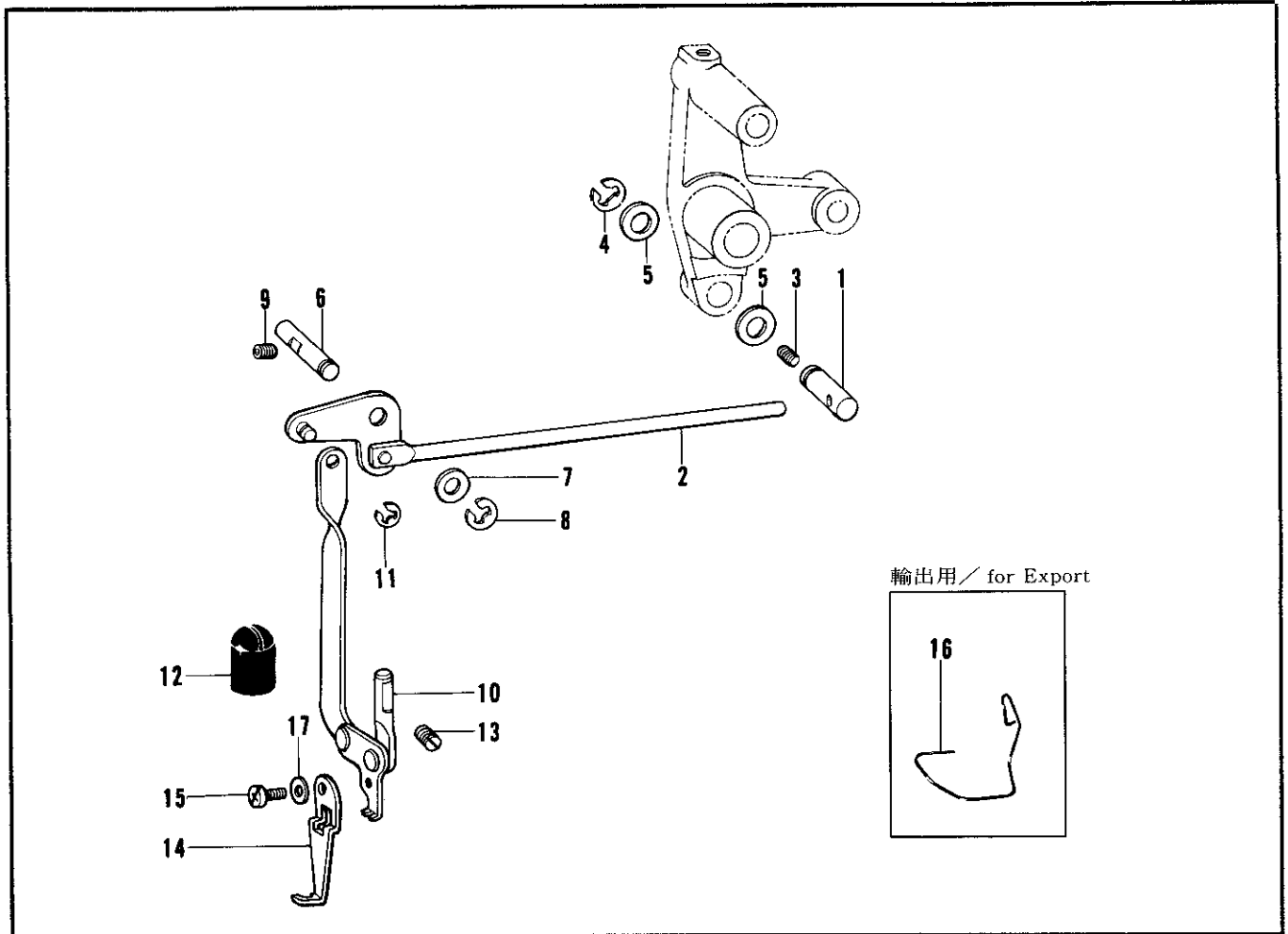

Q. 糸締×関係 / Thread nipper mechanism / Fadenspannvorrichtung
 Mécanisme de pince-fil / Mecanismo de mordaza para hilos

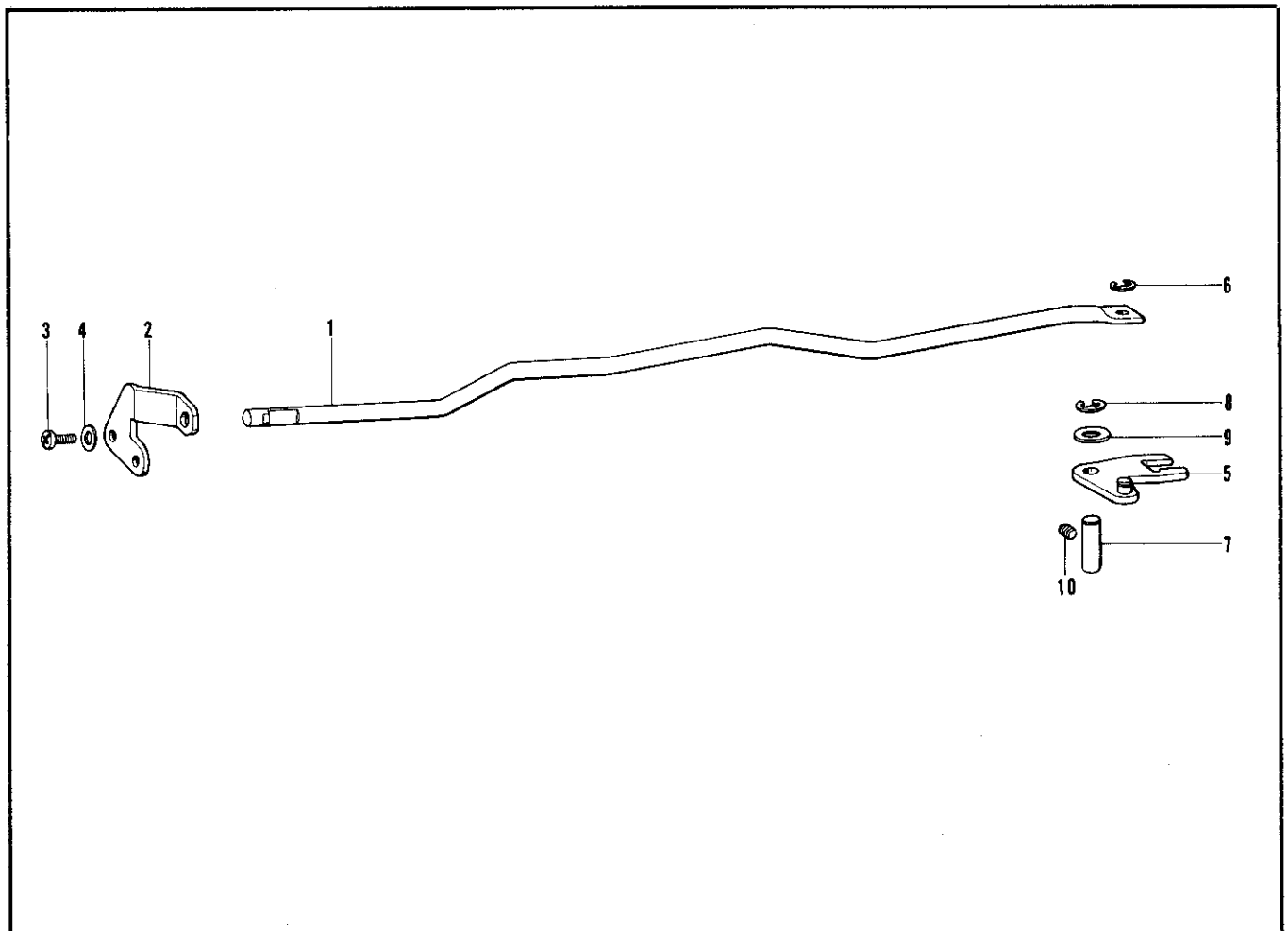

P. 糸払い関係 / Thread wiper mechanism / Fadenwischvorrichtung
 Mécanisme de tire-fil / Mecanismo de limpiador de hilos

REF.NO.	CODE	Q'TY	ヒンメイ	NAME OF PARTS	RMKS
1	152815001	1	ワイパーロッド"シ"ク	THREAD WIPER ROD SHAFT	
2	152816001	1	ワイパーロッド"クミ	THREAD WIPER ROD ASSEMBLY	
3	014680622	1	アナトメネシ"4.37クホ"ミ	SCREW 4.37	
4	048060342	1	トメフE6	STOP RING E6	
5	116629001	2	サ"ガ"ネ	WASHER	
6	152822001	1	ワイパー"シ"ク	THREAD WIPER SHAFT	
7	025770232	1	ヒラサ"ガ"ネチユウ6.35	WASHER 6.35	
8	048040342	1	トメフE4	STOP RING E4	
9	014680622	1	アナトメネシ"4.37クホ"ミ	SCREW 4.37	
10	152823001	1	ワイパー"ウテ"クミ	THREAD WIPER ARM ASSEMBLY	
11	048030342	1	トメフE3	STOP RING E3	
12	152827001	1	オイルキリセン	OIL CAP	
13	013710712	1	トメネシ"4.76クホ"ミ	SCREW 4.76	
14	156206001	1	ワイパー-A	-----	
15	062670512	1	ナヘ"ゴ357-40X5	SCREW 357-40X5	
16	S00926101	1	-----	FINGER GUARD	
17	025350132	1	ヒラサ"ガ"ネシヨウ	WASHER	

Q. 糸締メ関係 / Thread nipper mechanism / Fadenspannvorrichtung
 Mécanisme de pince-fil / Mecanismo de mordaza para hilos

REF.NO.	CODE	Q'TY	ヒンメイ	NAME OF PARTS	RMKS
1	152925101	1	ウワイトユルメホ"ウ	TENSION RELEASE BAR	
2	152926001	1	ユルメホ"ウササエイタ	TENSION RELEASE BAR PLATE	
3	062671012	2	ナヘ"ゴ357-40X10	SCREW 357-40X10	
4	025350332	2	ヒラサ"ガ"ネタ"イ3.5	WASHER 3.5	
5	152988001	1	ウワイトユルメレハ"ークミ	TENSION RELEASE LEVER ASSEMBLY	
6	048040342	1	トメフE4	STOP RING E4	
7	152929001	1	ウワイトユルメレハ"ー"シ"ク	TENSION RELEASE LEVER SHAFT	
8	048050342	1	トメフE5	STOP RING E5	
9	025770232	1	ヒラサ"ガ"ネチユウ6.35	WASHER 6.35	
10	014760622	1	アナトメネシ"5.95クホ"ミ	SCREW 5.95	

R. 動車・遊車関係/Drive pulley and idler pulley mechanism/Antriebsriemenscheibe und Riemenscheibe
 Mécanisme de poulie d'entraînement et poulie folle/Mecanismo de polea impulsora y polea tensora

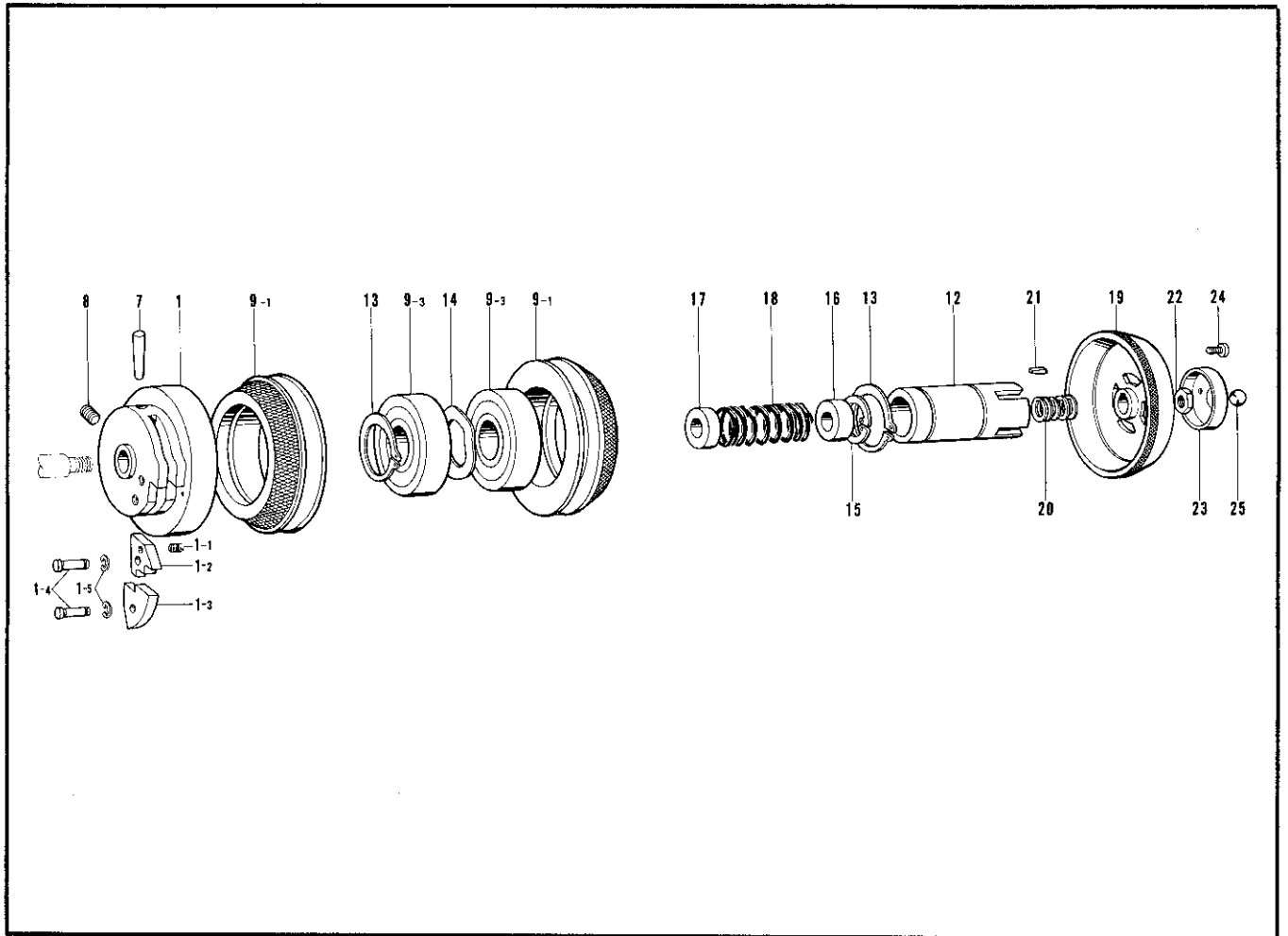

S. シャンクアタッチメント装置(特別注文部品)/Shank attachment (Option parts)/Knopfannahvorrichtung (Sonderzubehör)
 Accessoire de talon (Pièces en option)/Mecanismo de la caña (Piezas opcion)

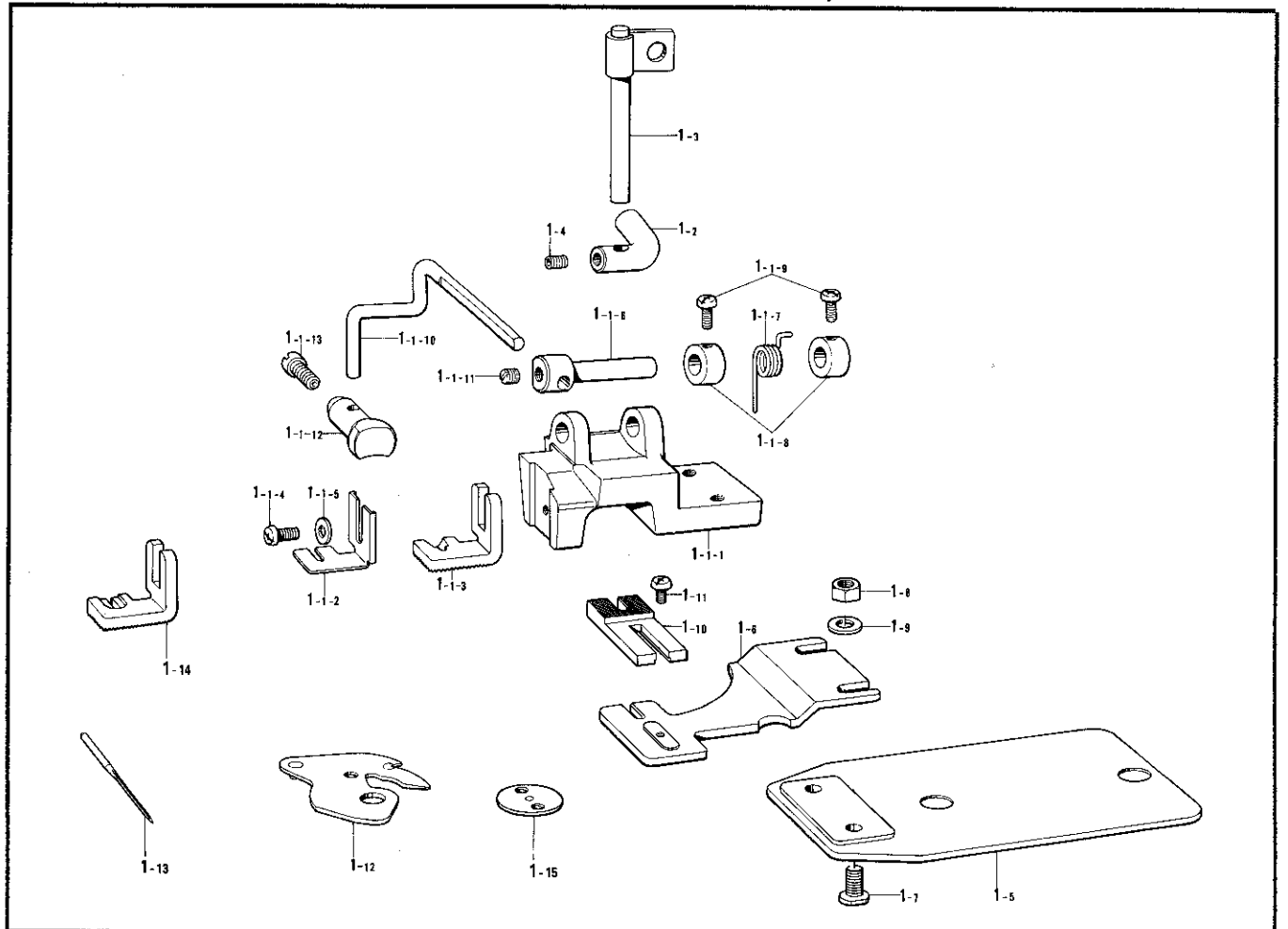

R. 動車・遊車関係/Drive pulley and idler pulley mechanism/Antriebsriemenscheibe und Riemenscheibe
Mécanisme de poulie d'entraînement et poulie folle/Mecanismo de polea impulsora y polea tensora

REF.NO.	CODE	Q'TY	ヒンメイ	NAME OF PARTS	RMKS
1	153044001	1	ストップカムクミ	STOP CAM ASSEMBLY	
1-1	152693001	1	セイト"ウカムヘン	BRAKE CAM SEGMENT	
1-2	152694001	1	セイト"ウカムヘンハ"ネ	BRAKE CAM SEGMENT SPRING	
1-3	115003001	1	カンシヨウカムヘン	FLANGE CAM SEGMENT	
1-4	153058001	2	カムヘンジ"ク	CAM SEGMENT STUD	
1-5	048040342	2	トメワE4	STOP RING E4	
7	147111001	1	テーパ"ピン6X35	TAPER PIN 6X35	
8	014770622	1	アナトメネシ"6.35クホ"ミ	SCREW 6.35	
9	156935101	2	プー"リソウクミ	PULLEY ASSEMBLY	
9-1	152695201	2	プー"リクミ	PULLEY ASSEMBLY	
9-2	072600760	2	タマシ"クウケ6007VV	BALL BEARING 6007VV	
12	152698001	1	スライド"メタル	SLIDE METAL	
13	048350142	2	トメワシ"クヨウC35	STOP RING C35	
14	152699001	1	ナミワツシヤ	WASHER	
15	048240242	1	トメワアナヨウ C24	STOP RING C24	
16	152700000	1	スライド"ブ"ツシユA	SLIDE BUSH A	
17	151946000	1	スライド"ブ"ツシユB	SLIDE BUSH B	
18	152701001	1	クラツチハ"ンハ"ネ	CLUTCH SPRING	
19	152702001	1	クラツチハ"ン	CLUTCH PLATE	
20	152703100	5	スペ"ーサ	SPACER	
21	S02878000	1	ハイコウキ3X3X13	KEY 3X3X13	
22	152705001	1	ナツト10ヒタ"リ	NUT 10	
23	152706001	1	ホ"ールウケ	BALL BEARING	
24	062660712	4	ナヘ"コ318-40X7	SCREW 318-40X7	
25	071095250	1	コウキユウ3/8	STEEL BALL 3/8	

S. シャンクアタッチメント装置(特別注文部品)/Shank attachment (Option parts)/Knopfannahvorrichtung (Sonderzubehör)
Accessoire de talon (Pieces en option)/Mecanismo de la caña (Piezas opcion)

REF.NO.	CODE	Q'TY	ヒンメイ	NAME OF PARTS	RMKS
1	154694006	1	シャンクソウチクミ	SHANK BUTTON ATTACHMENT	
1-1	142689206	1	シャンクホ"タンツマミタイクミ	SHANK BUTTON CLAMP ASSEMBLY	
1-1-1	154684006	1	シャンクホ"タンツマミタイ	SHANK BUTTON CLAMP	
1-1-2	142677001	1	ホ"タンツマミA	BUTTON CLAMP A	
1-1-3	142678001	1	ホ"タンツマミB	BUTTON CLAMP B	
1-1-4	062670812	1	ナヘ"コ357-40X8	SCREW 357-40X8	
1-1-5	102707003	1	サ"カ"ネ	WASHER	
1-1-6	142681001	1	ホ"タンオサエジ"ク	BUTTON PRESSER STUD	
1-1-7	154685001	1	ホ"タンオサエジ"クハ"ネ	SPRING	
1-1-8	142706001	2	セツトカラ"ー	SET COLLAR	
1-1-9	062670712	2	ナヘ"コ357-40X7	SCREW 357-40X7	
1-1-10	154686001	1	ホ"タンオサエウテ"	BUTTON PRESSER ARM	
1-1-11	013719412	1	トメネシ"4.76クホ"ミ	SCREW 4.76	
1-1-12	142680001	1	ホ"タンオサエ	BUTTON PRESSER	
1-1-13	120990001	1	アタマツキトメネシ"4.37	SCREW 4.37	
1-2	154695001	1	ホ"タンオサエヒラキ	BUTTON PRESSER ARM LIFTER	
1-3	154696001	1	ホ"タンオサエヒラキジ"ク	BUTTON PRESSER ARM LIFTER STUD	
1-4	014680422	1	アナトメネシ"4.37クホ"ミ	SCREW 4.37	
1-5	154697001	1	オクリイタ"イ	FEED PLATE BASE	
1-6	156336001	1	シャンクホ"タンオクリイタ	SHANK BUTTON FEED PLATE	
1-7	154713001	2	シメネシ"4.76	SCREW 4.76	
1-8	021710212	2	ナツト2シユ4.76	NUT 4.76	
1-9	025710232	2	ヒラサ"カ"ネチユウ4.76	WASHER 4.76	
1-10	142686001	1	ヌノウケタ"イス	CLOTH RECEIVER S	
1-11	060670512	1	ハ"イント"357-40X5	SCREW 357-40X5	
1-12	152901001	1	イト"ウハクミ	MOVABLE KNIFE ASSEMBLY	
1-13	115040016	10	ミシンハ"リト"QX7#16	NEEDLE TOX7 #16	
1-14	S03641001	1	ホ"タンツカミD	BUTTON CLAMP D	
1-15	156154001	1	ハリアナイタ"フ	NEEDLE HOLE PLATE F	

Z. 付属品関係 / Accessories / Zubehör
Accessoires / Accesorios

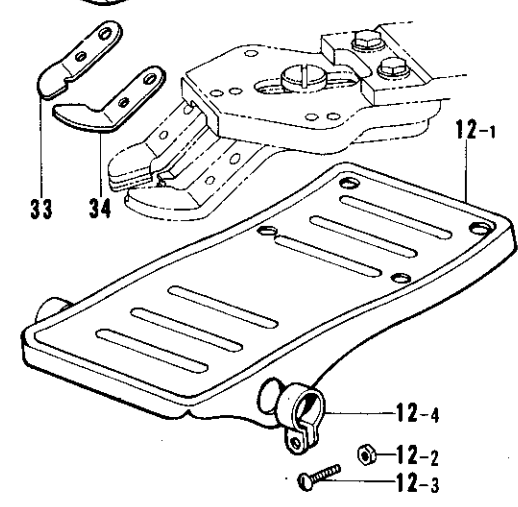
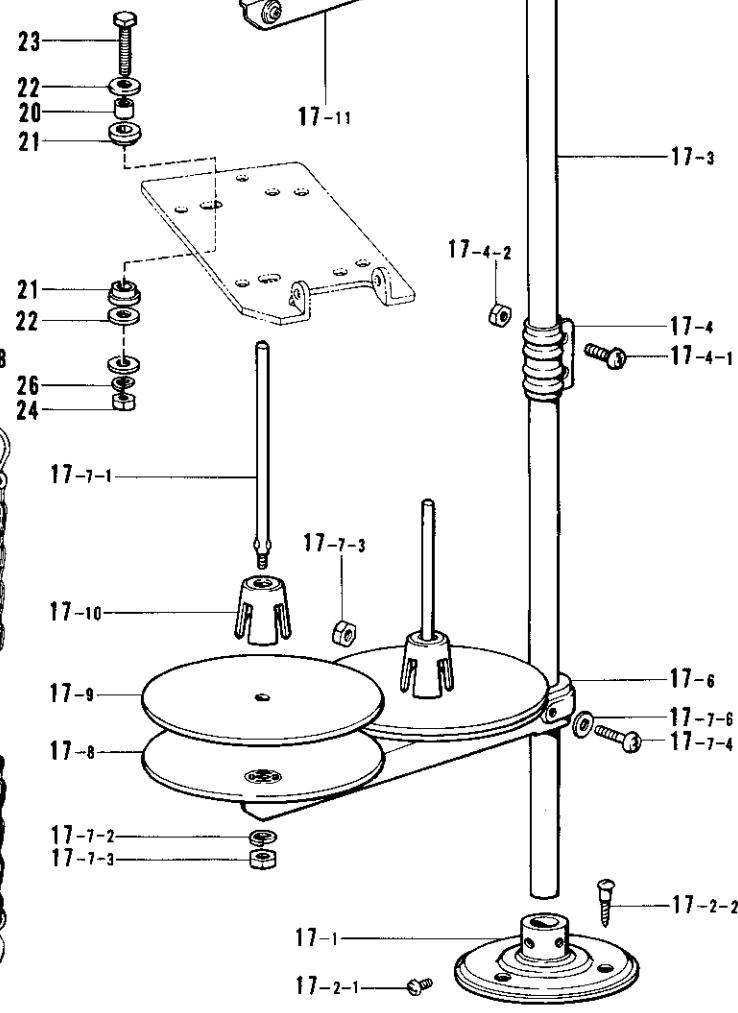
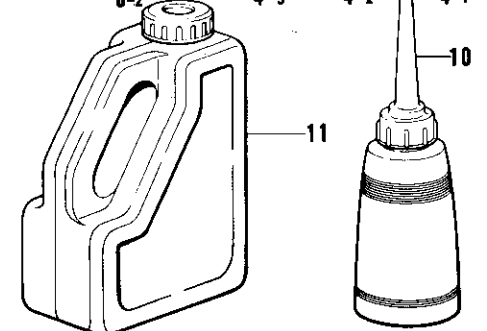
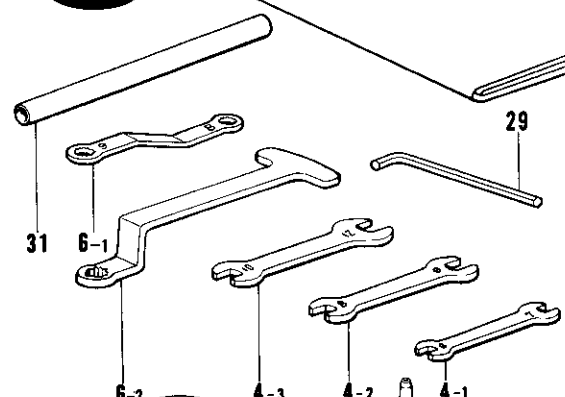
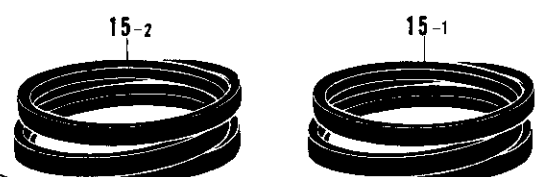
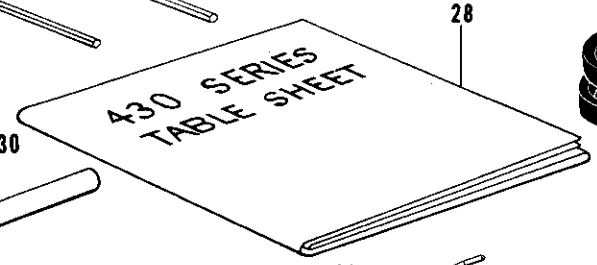
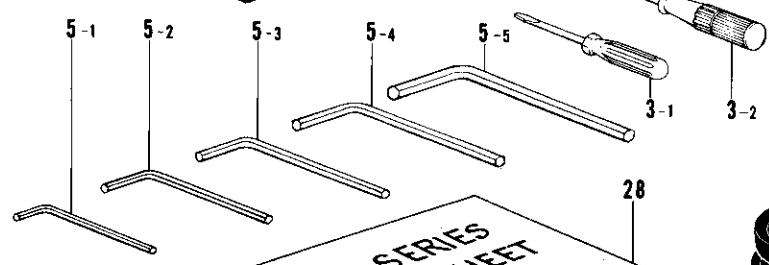
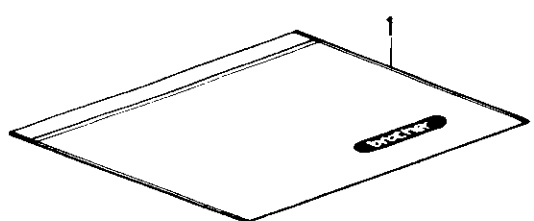
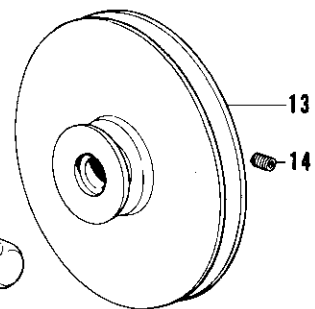
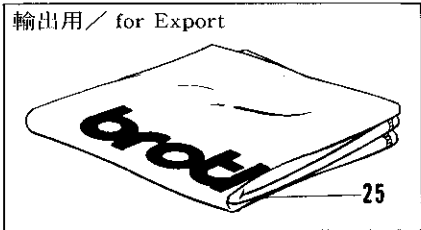

◎ 付属品の明細は変更することがあります。
 ◎ The details of included accessories are subject to change.
 ◎ Änderungen in der Aufstellung der mitgelieferten Zubehöre sind vorbehalten.

◎ Les détails des accessoires inclus sont sujets à des changements.
 ◎ Los detalles de los accesorios incluidos pueden variar.

Z. 付属品関係 / Accessories / Zubehör
Accessoires / Accesorios

REF.NO.	CODE	Q'TY	ヒンメイ	NAME OF PARTS	RMKS
1	122991001	1	フジクヒンホリフクロ	ACCESSORY BAG	
3-1	142443001	1	ネジマワシ1.9X52	SCREW DRIVER 1.9X52	
3-2	118837001	1	ネジマワシ3.4X70	SCREW DRIVER 3.4X70	
3-3	101572101	1	ネジマワシ5.5X190	SCREW DRIVER 5.5X190	
4-1	107779001	1	スハナ6X7	SPANNER 6X7	
4-2	100887001	1	スハナ8X9	SPANNER 8X9	
4-3	107780001	1	スハナ10X12	SPANNER 10X12	
5-1	142002001	1	6カクホウスハナ2	ALLEN WRENCH 2	
5-2	142721001	1	6カクホウスハナ3	ALLEN WRENCH 3	
5-3	118064001	1	6カクホウスハナ4	ALLEN WRENCH 4	
5-4	150335001	1	6カクホウスハナ5	ALLEN WRENCH 5	
5-5	115157001	1	6カクホウスハナ6	ALLEN WRENCH 6	
6-1	105343001	1	メガネレンチ8X9	WRENCH 8X9	
6-2	152765001	1	メガネレンチ10	WRENCH 10	
7	159613001	4	ボビン	BOBBIN	
9	115053016	4	ミシンハリTQX1#16	NEEDLE TQX1 #16	
10	114483002	1	ホリオリークミ	OILER	
11	154702001	1	オイルタンク	OIL TANK	
12	116185202	1	ペダルクミ	PEDAL ASSEMBLY	
12-1	117437102	1	オサエアケフミイタ	PEDAL	
12-2	021400106	2	1シユナツト4	NUT 4	
12-3	062401416	2	ナヘコ4X14	SCREW 4X14	
12-4	116016001	2	ペダルトメ	PEDAL STOPPER	
13	*	1	モータプーリ	MOTOR PULLEY	
14	014760622	2	アナトメネジ5.95クホミ	SCREW 5.95	
15-1	082104890	1	Vベルト48	V BELT 48	
15-2	*	1	VベルトM51	V BELT M	
17	S02761001	1	イトタテダイクミ2	COTTON STAND ASSEMBLY 2	
17-1	150189002	1	ブラケット	COTTON STAND BASE	
17-2	S02773001	1	ブラケットネジセット	COTTON STAND BASE SCREW SET	
17-2-1	062060806	2	ナヘコ6X8	SCREW 6X8	
17-2-2	031452206	3	マルモク45X22	SCREW 45X22	
17-3	150172002	2	コラムパイプ	COLUMN PIPE	
17-4	150106002	1	コラムジョイントクミ	COLUMN JOINT ASSEMBLY	
17-4-1	062501406	2	ナヘコ5X14	SCREW 5X14	
17-4-2	021500106	2	1シユナツト5	NUT 5	
17-5	150174000	1	コラムキャップ	COLUMN CAP	
17-6	S02778001	1	スプールホルダー2	SPOOL HOLDER 2	
17-7	S02780001	1	スプールネジセット2	SPOOL SCREW SET 2	
17-7-1	150179002	2	スプールシャフトB	SPOOL SHAFT B	
17-7-2	028050246	2	ハネサカネ2-5	SPRING WASHER 2-5	
17-7-3	021500106	4	1シユナツト5	NUT 5	
17-7-4	062503006	1	ナヘコ5X30	SCREW 5X30	
17-7-5	062501406	1	ナヘコ5X14	SCREW 5X14	
17-7-6	026050136	2	ヒラサカネコガタ5	WASHER 5	
17-8	150180000	2	ウケサラ	SPOOL STAND BASE	
17-9	150182000	2	スプールマット	SPOOL MAT	
17-10	126863001	2	スプールクッション	SPOOL CUSHION	
17-11	S02786001	1	スレッドハンガーークミ2	THREAD HANGER ASSEMBLY 2	
18	149247001	1	クサリクミ	CHAIN ASSEMBLY	
19	106030001	4	サラモクネジ6.2X32	SCREW 6.2X32	
20	152863001	4	クッションカラー	CUSHION COLLAR	
21	152864000	8	クッション	CUSHION	
22	025800332	12	ヒラサカネタイ7.14	WASHER 7.14	
23	017062503	4	6カクホルト6X25	BOLT 6X25	
24	021060102	4	ナツト1シユ6	NUT 6	
25	144226001	1	-----	HEAD COVER	
26	028060242	4	ハネサカネ2-6	SPRING WASHER 2-6	
28	153574201	1	テーブルシート	TABLE SHEET	
29	154179001	1	6カクホウスハナ4	ALLEN WRENCH 4	
30	120448001	1	ゴムワ	RUBBER RING	
31	154760001	1	ホウスハナパイプ	PIPE	

Z. 付属品関係 / Accessories / Zubehör
 Accessoires / Accesorios

輸出用 / for Export

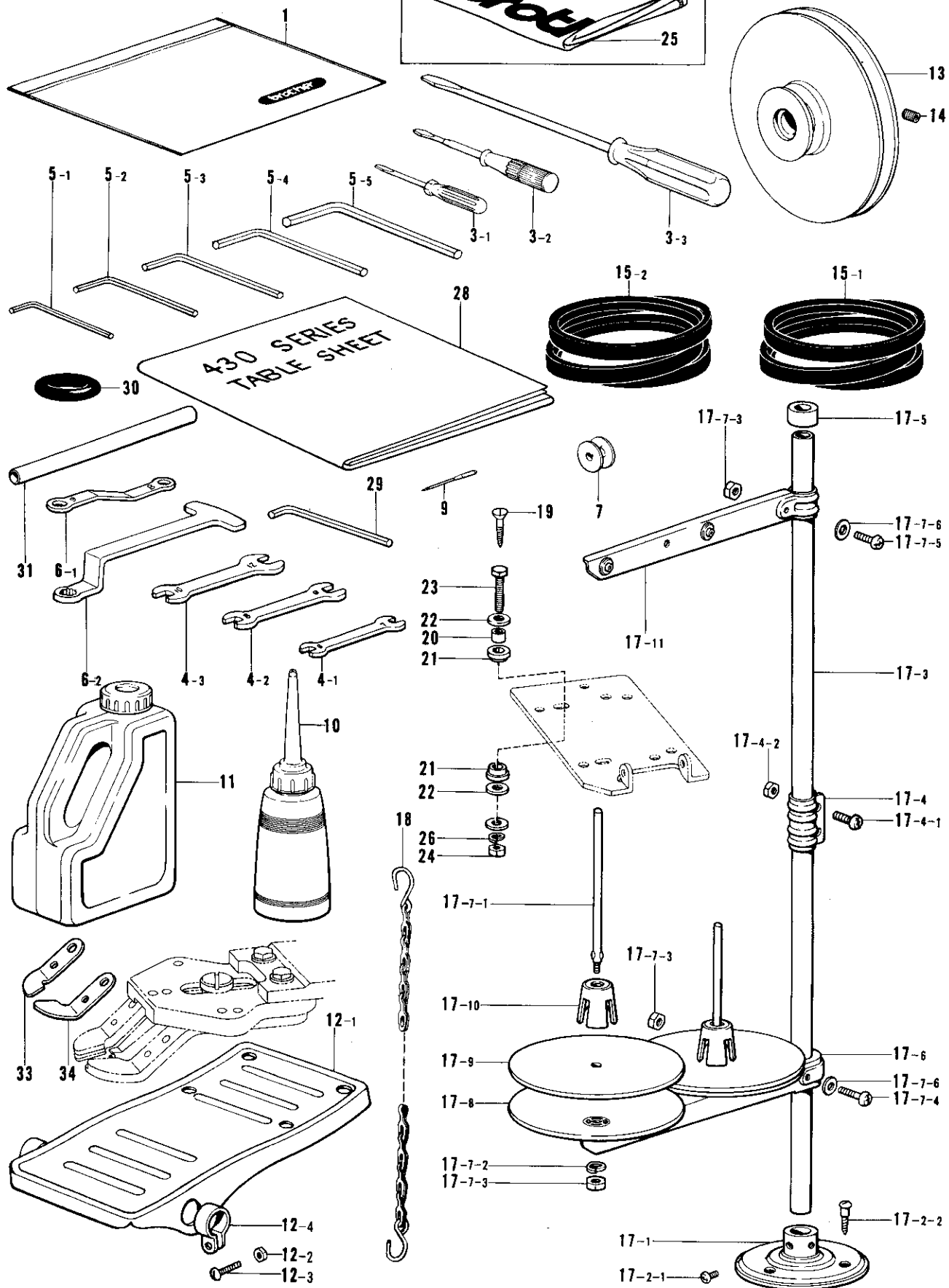
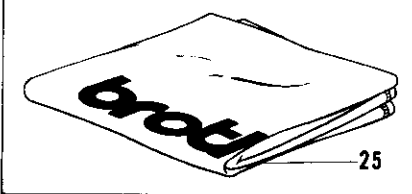

◎ 付属品の明細は変更することがあります。
 ◎ The details of included accessories are subject to change.
 ◎ Änderungen in der Aufstellung der mitgelieferten Zubehöre sind vorbehalten.

◎ Les détails des accessoires inclus sont sujets à des changements.
 ◎ Los detalles de los accesorios incluidos pueden variar.

Z. 付属品関係 / Accessories / Zubehör
 Accessoires / Accesorios

REF.NO.	CODE	Q'TY	ヒンメイ	NAME OF PARTS	RMKS
33	150398101	1	ホ"タンツカミLイタハ"ネ	BUTTON CLAMP (L) PLATE SPRING	
34	150401101	1	ホ"タンツカミRイタハ"ネ	BUTTON CLAMP (R) PLATE SPRING	

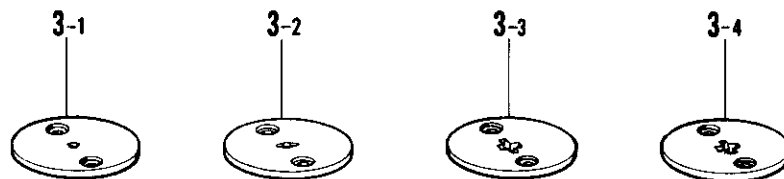
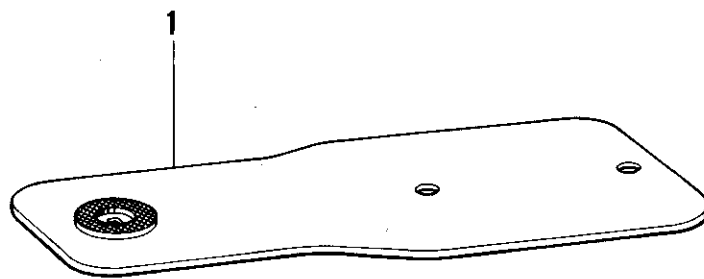
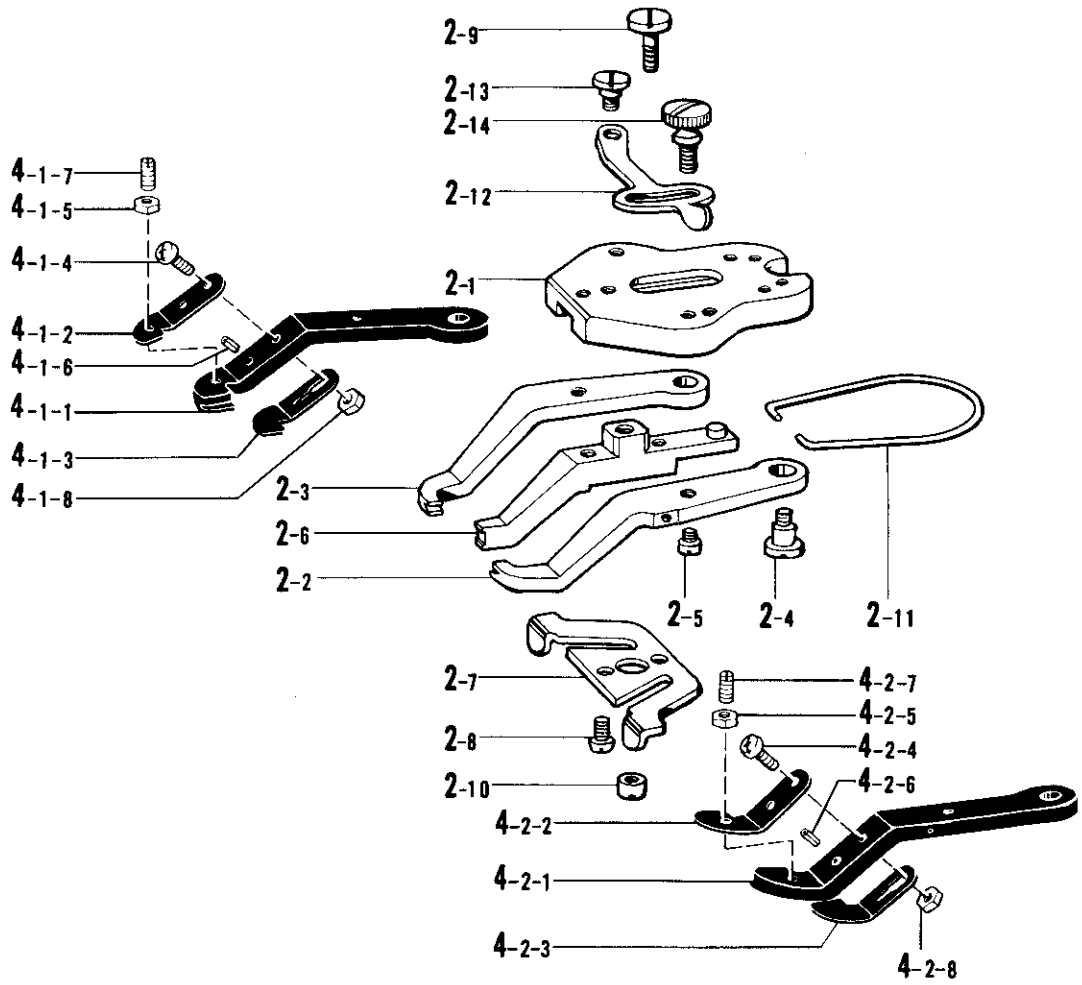

特別注文部品/OPTION PARTS/SONDERZUBEHÖR
PIECES EN OPTION/PIEZAS EN OPCION

REF.NO.	CODE	Q'TY	品名	NAME OF PARTS	RMKS
1	154665101	1	オクリイタ	FEED PLATE	
2	S03636001	1	スナップツマミクミ	SNAP BUTTON CLAMP ASSEMBLY	
2-1	S03464001	1	ボタンツカミタイ	BUTTON CLAMP BRACKET	
2-2	118539001	1	スナップツマミR	SNAP CLAMP (R)	
2-3	118541001	1	スナップツマミL	SNAP CLAMP (L)	
2-4	115158001	2	ダンネジ4.76	STUD SCREW 4.76	
2-5	115156001	2	ボタンツカミアンナイピン	PIN	
2-6	S03712001	1	スナップツマミMクミ	BUTTON CLAMP BRACKET ASSEMBLY	
2-7	S03659001	1	ボタンツカミイタカム	BUTTON CLAMP PLATE	
2-8	062680812	2	ナベコ437-40×8	SCREW 437-40×8	
2-9	S03468001	1	シメネジ4.37	SCREW 4.37	
2-10	S03657001	1	マルナット4.37	NUT 4.37	
2-11	115163001	1	ボタンツカミイタバネ	SPRING	
2-12	115164001	1	ボタンツカミチョウセツイタ	BUTTON CLAMP ADJUSTING PLATE	
2-13	115165001	1	ダンネジ4.37	STUD SCREW 4.37	
2-14	115166001	1	ダンネジ4.37	STUD SCREW 4.37	
3-1	156149001	1	ハリアナイタA	NEEDLE HOLE PLATE A	
3-2	156150001	1	ハリアナイタB	NEEDLE HOLE PLATE B	
3-3	156151001	1	ハリアナイタC	NEEDLE HOLE PLATE C	
3-4	156152001	1	ハリアナイタD	NEEDLE HOLE PLATE D	
4-1	S08612001	1	ボタンツカミLクミ	BUTTON CLAMP (L) Assembly	
4-1-1	S08613001	1	ボタンツカミL	BUTTON CLAMP (L)	
4-1-2	150398101	1	ボタンツカミLイタバネ	BUTTON CLAMP (L) PLATE SPRING	
4-1-3	S08615001	1	ボタンツカミLイタバネD	BUTTON CLAMP (L) PLATE SPRING D	
4-1-4	062681012	1	ナベコ437-40×10	SCREW 437-40×10	
4-1-5	021680202	1	ナット2シュ4.37	NUT 4.37	
4-1-6	047250642	1	スプリングピンAW2.5	SPRING PIN AW 2.5	
4-1-7	103978002	1	トメネジ3.18	SCREW 3.18	
4-1-8	021660102	1	ナット1シュ3.18	NUT 3.18	
4-2	S08616001	1	ボタンツカミRクミ	BUTTON CLAMP (R) ASSEMBLY	
4-2-1	S08617001	1	ボタンツカミR	BUTTON CLAMP (R)	
4-2-2	150401101	1	ボタンツカミRイタバネ	BUTTON CLAMP (R) PLATE SPRING	
4-2-3	S08619001	1	ボタンツカミRイタバネD	BUTTON CLAMP (R) PLATE SPRING D	
4-2-4	062681012	1	ナベコ437-40×10	SCREW 437-40×10	
4-2-5	021680202	1	ナット2シュ4.37	NUT 4.37	
4-2-6	047250642	1	スプリングピンAW2.5	SPRING PIN AW 2.5	
4-2-7	103978002	1	トメネジ3.18	SCREW 3.18	
4-2-8	021660102	1	ナット1シュ3.18	NUT 3.18	

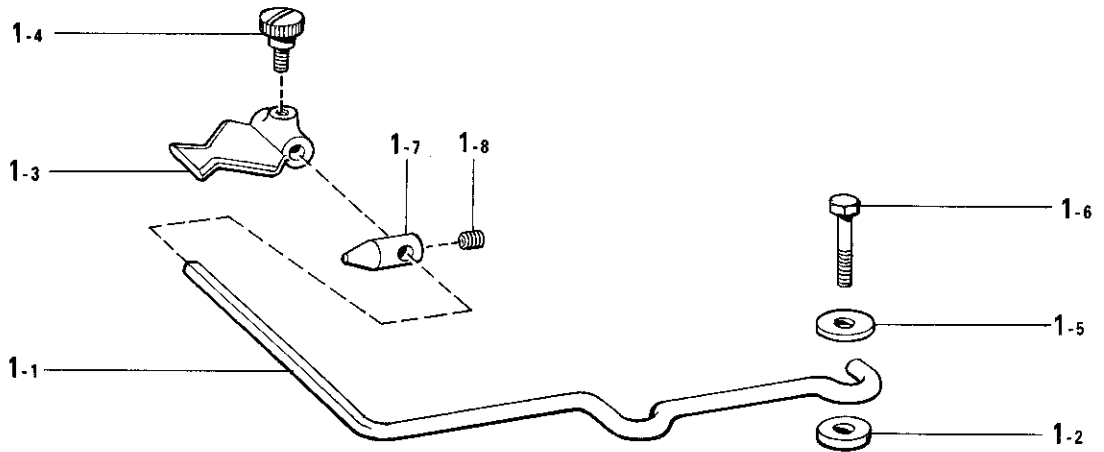

ウワジクミ 438
UPPER SHAFT ASSEMBLY 438
S01689-001

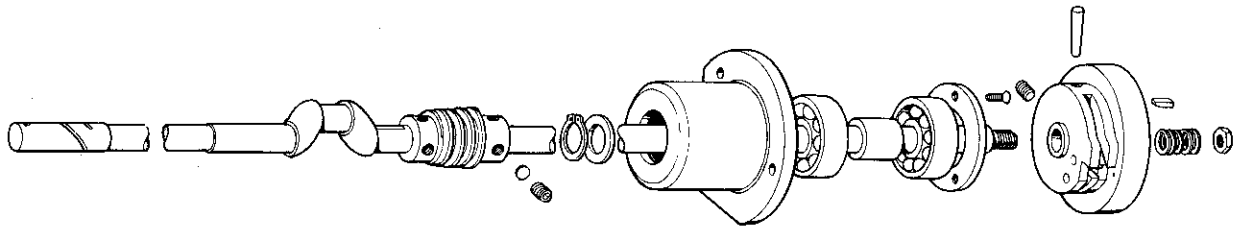

特別注文部品/OPTION PARTS LIST/SONDERZUBEHÖR
 PIECES EN OPTION/PIEZAS EN OPCION

REF.NO.	CODE	Q'TY	品名	NAME OF PARTS	RMKS
1	156440001	1	ボタン Spacer セット	BUTTON SPACER ASSEMBLY	
1-1	156441001	1	Spacer ロッド	SPACER ROD	
1-2	122257001	2	ワッシャー	WASHER	
1-3	156443001	1	Spacer	SPACER	
1-4	129984001	1	ツマミネジ 3.57	SCREW 3.57	
1-5	116662004	2	ワッシャー	WASHER	
1-6	154835001	2	ボルト 4.37	BOLT	
1-7	156342001	1	Spacer B	SPACER B	
1-8	014680422	1	アタネネジ 4.37 クボミ	SCREW 4.37	

仕様別部品一覧表/DIFFERENT PARTS LIST/ZUBEHÖRLISTE
 LISTE DES PIECES ACCESSOIRES/LISTA DE PIEZAS ACCESORIAS

REF.NO.	サブクラス SUB CLASS	-2	-3	-4	-7	
					エシユツシヨウ FOR EXPORTSPEC.	
	ヒンメイ PARTS					
A-62	シヨウラベル ----- LABEL	153056102	153056103	153056104	153056107	
A-69	ハリカス"キリカエキ ----- STITCH REGULATOR	153846001			156493001(B)	
H-1	ウォーム ----- WORM	153841001(36)			152707001	
H-4	ウォームホイール ----- WORM WHEEL	153840000(36)			152708000	
H-22	オクリカム ----- FEED CAM	156101001	156102001	156103001	156447001	
H-28	クラッチカム ----- CLUTCH CAM	153842001(36)			156446001(14)	
H-31	イトキリカム ----- KNIFE CAM	152730001			156445001(14)	
Z-13	モータプーリ 2000/50 ----- MOTOR PULLEY 2000/50	153107001				
	モータプーリ 2000/60 ----- MOTOR PULLEY 2000/60	153106001				
Z-15-2	Vベルト M51 ----- V BELT M51	082105190				
	Vベルト M52 ----- V BELT M52	082105290				

CODE	REF.NO.	PAGE
S00327001	J - 16	22
S00400000	J - 16-11	22
S00926101	P - 16	34
S01300001	M - 3	30
S01887001	N - 6-2	32
S01888006	A - 16-2	2
S02761001	Z - 17	38
S02773001	Z - 17-2	38
S02778001	Z - 17-6	38
S02780001	Z - 17-7	38
S02786001	Z - 17-11	38
S02878000	R - 21	36
S03464101	G - 21-1	18
S03465101	G - 21-2	18
S03466101	G - 21-4	18
S03467001	G - 21-10	18
S03468001	G - 21-13	18
S03641001	S - 1-14	36
S03657001	G - 21-14	18
S03659001	G - 21-11	18
S09132001	E - 12	14
	H - 20	20
	H - 29	20
	H - 32	20
013710712	H - 37	20
	H - 40	20
	P - 13	34
013719412	A - 32-8	2
	S - 1-1-11	36
013760612	A - 52	2
	F - 5	16
	L - 32	28
013761410	B - 32	6
013761412	C - 14	10
	C - 21	10
014680422	L - 28	28
	L - 34	28
	M - 1-18	30
	S - 1-4	36
014680622	G - 12	18
	J - 3	22
	P - 3	34
	P - 9	34
014760622	A - 76	4
	B - 34	6
	B - 74	8
	D - 19-3	12
	D - 21	12
	D - 30	12
	E - 3	14
	E - 6-4	14
	E - 18	14
	E - 23	14
	E - 30-3	14
	E - 32	14
	F - 4	16
	F - 10	16
	F - 16	16
	F - 28	16
	G - 1-4	18
	G - 14	18
	H - 10	20
	H - 45	20
	J - 6	22
	J - 8	22
	J - 11	22
	J - 17	22

CODE	REF.NO.	PAGE
014760622	N - 26	32
	N - 30	32
	N - 42	32
	Q - 10	34
	Z - 14	38
014770622	A - 74	4
	C - 17	10
	C - 19	10
	J - 15	22
	R - 8	36
014821022	B - 6	6
	D - 29	12
017062503	Z - 23	38
017711412	B - 59	8
	G - 16	18
017761212	E - 40	14
017761412	C - 9	10
017762202	B - 66	8
018060822	D - 10-3	12
018061622	B - 77	8
	H - 42	20
018062022	B - 56	8
	G - 2	18
	H - 8	20
	H - 25	20
018062222	H - 18	20
018063022	E - 12-1	14
	H - 20-1	20
	H - 29-1	20
	H - 32-1	20
018081222	A - 32-3	2
018082022	E - 4-1	14
	E - 30-4	14
018082522	B - 11	6
018501422	J - 25	22
018681022	N - 3	32
021060102	Z - 24	38
021100202	A - 32-15	2
021400106	Z - 12-2	38
021500106	Z - 17-4-2	38
	Z - 17-7-3	38
021670202	K - 12-7	24
021680202	B - 39-7	6
021710212	S - 1-8	36
021800102	B - 22	6
025030132	E - 46	14
025060132	B - 78	8
	N - 21	32
025060232	B - 80	8
	C - 10	10
	E - 39	14
	G - 3	18
025080132	A - 65	4
025080232	A - 32-4	2
025100132	A - 32-16	2
025350132	P - 17	34
025350332	K - 12-4	24
	Q - 4	34
025660132	G - 21-23	18
025680132	A - 71	4
	B - 39-6	6
025710232	S - 1-9	36
025770232	A - 11	2
	P - 7	34
	Q - 9	34
025800332	B - 20	6
	Z - 22	38

CODE	REF.NO.	PAGE
026050136	Z - 17-7-6	38
028040242	K - 51	26
028050242	B - 45	6
	B - 60	8
028050246	Z - 17-7-2	38
028060242	B - 79	8
	H - 27	20
	Z - 26	38
028080242	A - 32-5	2
	B - 12	6
028100242	A - 32-17	2
031452206	Z - 17-2-2	38
046301620	J - 9-1	22
046302020	H - 43-1-1	20
047250642	G - 21-8	18
047251640	K - 37	24
047501242	A - 84	4
048030342	B - 39-4	6
	P - 11	34
048040342	B - 27	6
	B - 55-3	8
	H - 43-4	20
	L - 30	28
	N - 18-3	32
	N - 28	32
	P - 8	34
	Q - 6	34
	R - 1-5	36
048050342	M - 1-17	30
	N - 5	32
	N - 37	32
	Q - 8	34
048060342	F - 12	16
	F - 19	16
	P - 4	34
048080342	J - 23	22
048100142	A - 32-13	2
048110142	B - 31	6
	B - 73	8
	F - 27	16
	N - 40	32
048120142	N - 24	32
048150142	C - 3	10
048160142	D - 26	12
048170142	D - 2	12
048180142	B - 4	6
	E - 15	14
	E - 22	14
048240242	R - 15	36
048320242	A - 32-2-1	2
048350142	R - 13	36
060660512	E - 45	14
060670512	S - 1-11	36
062060806	Z - 17-2-1	38
062401416	Z - 12-3	38
062501406	Z - 17-4-1	38
	Z - 17-7-5	38
062503006	Z - 17-7-4	38
062660412	J - 16-4	22
062660712	J - 16-8	22
	R - 24	36
062670412	H - 49	20
	L - 45	28
062670512	A - 57	2
	K - 21	24
	K - 26	24
	K - 33	24

CODE	REF.NO.	PAGE
062670512	K - 39	24
	K - 48	26
	K - 50	26
	P - 15	34
062670612	K - 13	24
	L - 4	28
	L - 40	28
062670712	M - 1-9	30
	M - 1-19	30
	S - 1-1-9	36
062670812	A - 15	2
	K - 12-3	24
	S - 1-1-4	36
062671012	Q - 3	34
062671412	K - 12-8	24
062680512	G - 21-7	18
062680612	A - 59	2
	A - 70	4
	K - 5	24
062680712	M - 1-11	30
062680812	A - 22	2
	A - 64	4
	C - 20-7	10
	G - 21-12	18
	K - 54	26
062681012	K - 3	24
	M - 7	30
062710612	A - 81	4
	G - 21-21	18
062710712	A - 6	2
	L - 2	28
062711412	A - 5	2
	A - 8	2
062761412	A - 3	2
	M - 2	30
	N - 20	32
062781412	C - 35	10
071047650	E - 38	14
071095250	R - 25	36
072600360	D - 6	12
072600760	R - 9-2	36
072630260	C - 5	10
081003670	J - 13	22
	J - 19	22
081008070	N - 52	32
082104890	Z - 15-1	38
082105190	Z - 15-2	38
082105290	Z - 15-2	38
100032004	N - 43	32
100136001	L - 15	28
	L - 27	28
100250001	C - 16	10
100253001	C - 20-4	10
100315002	A - 10	2
100360003	N - 16	32
100398001	L - 9	28
100402004	L - 10	28
100887001	Z - 4-2	38
101572101	Z - 3-3	38
101795001	A - 77	4
102538007	A - 56-3	2
102630001	F - 8	16
102707003	S - 1-1-5	36
102716004	M - 1-5	30
	M - 1-22	30
102843004	C - 8	10
103950003	L - 18	28

CODE	REF.NO.	PAGE
104450101	A - 31	2
104450101	A - 66	4
104525001	M - 3-3	30
104567001	K - 10	24
	K - 22	24
	K - 40	24
104689002	B - 23	6
	J - 2	22
105234003	F - 32	16
	G - 13-4	18
105248003	K - 65	26
105343001	Z - 6-1	38
106030001	Z - 19	38
106129001	A - 56-4	2
106147002	B - 37	6
107030001	B - 52-1	8
107149001	K - 59	26
107153002	F - 11	16
	F - 18	16
107231002	D - 9	12
107606001	L - 14	28
107744001	B - 39-2	6
	F - 30	16
	G - 13-2	18
107779001	Z - 4-1	38
107780001	Z - 4-3	38
108265001	M - 3-4	30
108520001	A - 30	2
109239002	A - 18	2
109893002	H - 26	20
110027001	H - 44	20
110215002	G - 21-22	18
110251001	B - 38	6
	B - 67	8
110495003	J - 14	22
110505001	B - 72	8
111140002	N - 13	32
111865001	B - 75	8
	D - 27	12
	N - 41	32
112468001	N - 36	32
112669001	K - 31	24
	K - 42	24
	K - 56	26
112751003	L - 6	28
113006001	K - 34	24
113316001	L - 5	28
113431002	B - 39-5	6
	B - 61	8
114294001	L - 17	28
114483002	Z - 10	38
114486002	A - 80	4
114985001	A - 58	2
115003001	R - 1-3	36
115012002	B - 13	6
115018001	B - 19	6
115040016	S - 1-13	36
115053016	C - 27	10
	Z - 9	38
115077003	L - 38	28
115138001	M - 1-13	30
115147001	G - 20	18
115148101	G - 19	18
115156001	G - 21-6	18
115157001	Z - 5-5	38
115158001	G - 21-9	18
115160001	A - 73	4

CODE	REF.NO.	PAGE
115163001	G - 21-15	18
115164001	G - 21-16	18
115165001	G - 21-17	18
115166001	G - 21-18	18
115270006	A - 72	4
115493002	A - 17	2
116016001	Z - 12-4	38
116185202	Z - 12	38
116231001	E - 16-1	14
116629001	P - 5	34
116920001	C - 36	10
117150001	K - 25	24
	K - 38	24
	B - 44	6
117363001	Z - 12-1	38
117437102	Z - 12-1	38
117934001	A - 29	2
117936001	A - 27	2
118064001	Z - 5-3	38
118837001	Z - 3-2	38
120448001	M - 1-21-2	30
	Z - 30	38
120990001	S - 1-1-13	36
122991001	Z - 1	38
123006001	C - 18	10
126863001	Z - 17-10	38
140208001	L - 29	28
	N - 27	32
140392001	A - 28	2
140423000	K - 2-5	24
	K - 28	24
140726000	C - 11	10
141331001	E - 36-3	14
141334001	H - 47	20
	N - 48	32
141472002	D - 23	12
141528001	L - 37	28
141550001	M - 1-14	30
141583001	F - 21	16
141692001	K - 12-6	24
141786001	J - 1	22
141808001	J - 34	22
141860001	A - 32-2-2	2
142002001	Z - 5-1	38
142211001	C - 33	10
142443001	Z - 3-1	38
142566001	M - 1-16	30
142628001	B - 30	6
	B - 71	8
	F - 26	16
	N - 39	32
142677001	S - 1-1-2	36
142678001	S - 1-1-3	36
142680001	S - 1-1-12	36
142681001	S - 1-1-6	36
142686001	S - 1-10	36
142689206	S - 1-1	36
142706001	S - 1-1-8	36
142721001	Z - 5-2	38
144226001	Z - 25	38
144458001	C - 24	10
144694001	K - 6	24
144712002	C - 2-1	10
145318001	E - 34	14
145446001	L - 12	28
	L - 22	28
	M - 3-2	30
145480001	A - 12	2

CODE	REF.NO.	PAGE
145519001	L - 11	28
146354001	G - 17	18
146375000	K - 23	24
146994001	G - 18	18
147111001	R - 7	36
147151000	H - 3	20
147745000	K - 2-6	24
	K - 15	24
	K - 43	24
148921000	K - 14	24
149247001	Z - 18	38
150106002	Z - 17-4	38
150172002	Z - 17-3	38
150174000	Z - 17-5	38
150179002	Z - 17-7-1	38
150180000	Z - 17-8	38
150182000	Z - 17-9	38
150189002	Z - 17-1	38
150335001	Z - 5-4	38
150398101	Z - 33	40
150401101	Z - 34	40
150553001	B - 53	8
	B - 64	8
	N - 33	32
150554002	B - 14	6
150556001	B - 46-3	6
	B - 48	6
	B - 51	6
	F - 20-3	16
	F - 22	16
151163001	B - 9	6
	H - 24	20
151602002	E - 1-3	14
151604002	A - 54	2
151886001	B - 1	6
151887001	B - 3	6
151888101	B - 10	6
151889001	B - 15	6
151890000	B - 16	6
151891001	B - 17	6
151892001	B - 18	6
151893001	B - 21	6
151894101	B - 24	6
151895000	B - 25	6
151898001	B - 26	6
151899001	B - 28	6
151900001	B - 29	6
151901001	B - 33	6
151902001	B - 35	6
151903001	B - 36	6
151904101	B - 39	6
151905101	B - 39-1	6
151906101	B - 39-3	6
151907001	B - 40	6
	B - 54	8
	N - 32	32
151908001	B - 41	6
151910001	B - 43	6
151912001	B - 47	6
151913001	B - 49	6
151914001	B - 50	6
151915001	B - 52	6
151919101	B - 57	8
151920001	B - 58	8
151922001	B - 65	8
151923001	B - 68	8
151924001	B - 69	8

CODE	REF.NO.	PAGE
151925001	B - 70	8
151927001	B - 2	6
151928001	D - 1	12
151929000	B - 7	6
151930201	D - 3	12
151932001	D - 8	12
151933001	D - 10-1	12
151935000	D - 10-1-1	12
151936001	D - 11	12
151937001	D - 12	12
151938001	D - 13	12
151939001	B - 55	8
151940001	D - 10-2	12
151941101	D - 10-4	12
151944001	D - 19	12
151946000	R - 17	36
151947101	D - 19-1	12
151948001	D - 19-2	12
151949001	D - 20	12
151951001	D - 22	12
151952001	D - 24	12
151953001	D - 25	12
151954001	D - 28	12
151968001	G - 13	18
151969001	G - 13-1	18
151995001	C - 1	10
151997000	C - 4	10
151998000	C - 6	10
151999001	C - 7	10
152000001	C - 13	10
152191001	J - 9	22
152236001	C - 20-2	10
152238001	C - 20-5	10
152239001	C - 20-6	10
152242001	C - 25	10
152244000	C - 34	10
152245001	J - 4	22
152246001	J - 5	22
152247001	J - 7	22
152250001	J - 10	22
152677001	J - 16-1	22
152678001	J - 12	22
	J - 18	22
152679001	J - 16-2	22
152680001	J - 16-3	22
152681101	J - 24	22
152682001	J - 26	22
152683001	J - 16-5	22
152684001	J - 16-6	22
152685101	J - 31	22
152693001	R - 1-1	36
152694001	R - 1-2	36
152695201	R - 9-1	36
152698001	R - 12	36
152699001	R - 14	36
152700000	R - 16	36
152701001	R - 18	36
152702001	R - 19	36
152703100	R - 20	36
152705001	R - 22	36
152706001	R - 23	36
152707001	H - 1	20
152708000	H - 4	20
152709000	H - 6	20
152710001	H - 7	20
152713001	H - 5	20
152718001	H - 2	20

CODE	REF.NO.	PAGE
152719000	H - 15	20
152720000	H - 16	20
152723001	H - 34	20
152724001	H - 19	20
152728001	B - 8	6
	H - 23	20
152730001	H - 31	20
152731001	H - 35	20
152732001	H - 36	20
152734001	H - 41	20
152735101	H - 43	20
152739001	H - 43-2	20
152742001	E - 1-1	14
152744001	F - 2-2	16
152745001	E - 2	14
	E - 31	14
152749001	E - 7	14
	E - 27	14
152750001	E - 8	14
	E - 28	14
152752001	E - 6-2	14
152755001	E - 11	14
152756001	B - 5	6
	E - 14	14
	E - 19	14
	E - 21	14
152759001	E - 17	14
152760001	E - 20	14
152765001	Z - 6-2	38
152766001	E - 33	14
152769001	E - 36	14
152771000	E - 36-1	14
152772001	E - 37	14
152773001	E - 36-2	14
152798001	F - 2-1	16
152799001	F - 3	16
152800201	F - 6	16
152801001	F - 7	16
152802001	F - 9	16
152803001	F - 13	16
152805101	F - 14-1	16
152806001	F - 14-2	16
152808101	B - 46	6
	F - 20	16
152811001	F - 23	16
152815001	P - 1	34
152816001	P - 2	34
152822001	P - 6	34
152823001	P - 10	34
152827001	P - 12	34
152830106	A - 2	2
152831006	A - 4	2
152832106	A - 4-1	2
152833001	A - 4-2	2
152835006	A - 9	2
152836006	A - 13	2
152838001	A - 60	4
152839001	A - 61	4
152841003	A - 14	2
152842006	A - 16-1	2
152846006	A - 19	2
152847000	A - 85	4
152848001	A - 63	4
152852101	A - 32-2	2
152857001	A - 32-6	2
152858001	A - 32-7	2
152859001	A - 32-9	2

CODE	REF.NO.	PAGE
152860001	A - 32-10	2
152861101	A - 32-11	2
152862001	A - 32-12	2
152863001	Z - 20	38
152864000	Z - 21	38
152865101	A - 32-14	2
152866001	A - 51	2
152867000	A - 53	2
152868000	A - 55	2
152869001	L - 1	28
152870001	L - 3	28
152872001	L - 8	28
152873001	L - 16	28
152874001	L - 19	28
152875001	L - 20	28
152876001	L - 21	28
152877001	L - 23	28
152878001	L - 24	28
152879101	L - 25	28
152880001	L - 26	28
152881001	L - 31	28
152883000	L - 43	28
152884001	L - 44	28
152886001	L - 33	28
152887001	L - 35	28
152888101	L - 36	28
152889001	L - 39	28
152890001	L - 41	28
152892001	N - 1	32
152893101	N - 4	32
152896001	N - 2	32
152897201	N - 9	32
152901001	N - 10	32
	S - 1-12	36
152904001	N - 11	32
152905001	N - 12	32
152906101	N - 50	32
152912001	N - 18-1	32
152913001	B - 55-1	8
	N - 18-2	32
152914001	B - 55-2	8
	H - 38	20
	N - 18-4	32
152915001	N - 19	32
152916001	N - 22	32
152917001	N - 23	32
152919001	N - 18-6	32
152920001	N - 29	32
152921001	N - 31	32
152922001	N - 34	32
152923001	N - 35	32
152925101	Q - 1	34
152926001	Q - 2	34
152929001	Q - 7	34
152933001	M - 1-3	30
152934001	M - 1-4	30
152935001	M - 1-6	30
152936001	M - 1-7	30
152937001	M - 1-8	30
152938001	M - 1-10	30
152939001	M - 1-12	30
152940001	M - 1-15	30
152941001	M - 1-20	30
152945001	M - 3-1	30
152948001	K - 1	24
	K - 11	24
152949001	K - 2	24

CODE	REF.NO.	PAGE
152950001	K - 2-1	24
152951001	K - 2-2	24
152952001	K - 2-3	24
152953001	K - 45	24
152955001	K - 4-2	24
152956001	K - 4-3	24
	K - 7	24
152958001	K - 4	24
152959001	K - 4-1	24
152960001	K - 9	24
152961001	K - 12	24
152962001	K - 8	24
152963001	K - 12-5	24
152964001	K - 17	24
	K - 19	24
152965001	K - 18	24
152966001	K - 12-1	24
152967001	K - 12-2	24
152968001	K - 60	26
152969001	K - 20	24
	K - 32	24
152971001	K - 29	24
152973001	K - 36-1	24
	K - 67	26
152974001	K - 41	24
152976001	K - 49	26
152977001	K - 52	26
152978001	K - 53	26
152980001	K - 70	26
	K - 71	26
152981001	N - 7	32
152982101	M - 1	30
152983001	M - 1-1	30
152984001	M - 1-2	30
152985001	K - 46	24
152986001	A - 21	2
152988001	Q - 5	34
152989001	A - 20	2
152992001	K - 24	24
152995001	N - 6-1	32
153035000	E - 43	14
153040001	C - 2	10
153041001	E - 1-2	14
153042001	E - 6-1	14
	E - 26-1	14
153044001	R - 1	36
153049001	L - 7	28
153050000	J - 16-9	22
153056102	A - 62	4
153056103	A - 62	4
153056104	A - 62	4
153056107	A - 62	4
153057002	E - 42	14
153058001	R - 1-4	36
153098000	A - 56-2	2
153100000	A - 56	2
153102001	A - 56-1	2
153104001	H - 17	20
153106001	Z - 13	38
153107001	Z - 13	38
153138001	L - 46	28
153141001	H - 48	20
153195001	H - 43-3	20
153208002	N - 44	32
153219001	N - 46	32
153220001	N - 45	32
153222001	N - 8	32

CODE	REF.NO.	PAGE
153330001	C - 20-1	10
153332001	H - 43-1	20
153482001	N - 38	32
153484001	F - 31	16
	G - 13-3	18
153528001	K - 64	26
153529001	K - 61	26
153530001	K - 62	26
153531001	K - 63-1	26
153562001	K - 63-2	26
153574201	Z - 28	38
153596001	N - 54	32
153597001	N - 53	32
153598001	N - 51	32
153763001	K - 47	24
153820101	E - 4	14
153823001	E - 26-2	14
153824001	E - 30-1	14
153826001	E - 44	14
153827001	G - 11	18
153828001	F - 29	16
153830006	G - 10	18
153831001	F - 1	16
153834001	G - 15	18
153835006	G - 1-1	18
153836101	G - 1-2	18
153838001	G - 1-3	18
153840000	H - 4	20
153841001	H - 1	20
153842001	H - 28	20
153843006	A - 75	4
153845001	H - 39	20
153846001	A - 69	4
153868106	A - 7	2
153918001	K - 2-4	24
153919001	K - 2-7	24
153921001	K - 36-2	24
153922001	K - 44	24
	K - 58	26
153924001	K - 66	26
153925001	K - 68	26
153926001	K - 69	26
153927001	K - 55	26
153988001	E - 6-3	14
153989001	E - 30-2	14
154155101	B - 63	8
154174001	E - 16	14
154179001	Z - 29	38
154332001	B - 46-1	6
	F - 20-1	16
154333001	B - 46-2	6
	F - 20-2	16
154465001	A - 79	4
154528001	M - 1-21-1	30
154561001	C - 20	10
154623000	C - 15	10
154624001	C - 20-3	10
154626001	L - 42	28
154627001	C - 26	10
154684006	S - 1-1-1	36
154685001	S - 1-1-7	36
154686001	S - 1-1-10	36
154694006	S - 1	36
154695001	S - 1-2	36
154696001	S - 1-3	36
154697001	S - 1-5	36
154701001	C - 22	10

CODE	REF.NO.	PAGE
154702001	Z - 11	38
154713001	S - 1-7	36
154738101	A - 32-1	2
154760001	Z - 31	38
154785000	A - 83	4
154788001	N - 25	32
154789001	N - 18-5	32
155336001	H - 46	20
155337001	H - 43-5	20
155489000	J - 16-10	22
155499001	B - 62	8
155500001	B - 76	8
155501001	B - 42	6
155523001	D - 10	12
156101001	H - 22	20
156102001	H - 22	20
156103001	H - 22	20
156107201	G - 21	18
156154001	S - 1-15	36
156206001	P - 14	34
156336001	S - 1-6	36
156445001	H - 31	20
156446001	H - 28	20
156447001	H - 22	20
156493001	A - 69	4
156935101	R - 9	36
158686001	F - 15	16
158687001	F - 24	16
159610101	J - 35	22
159613001	J - 36	22
	Z - 7	38
159805001	L - 13	28
159808001	A - 32	2
159938001	G - 21-19	18
159939001	G - 21-20	18
159940001	N - 17	32
159941001	G - 21-3	18
159942001	G - 21-5	18
159971001	E - 41	14
159977000	H - 9	20
159978001	H - 11	20
159979001	H - 12	20
159984001	H - 13	20
402887001	J - 16-7	22

brother

ブラザー工業株式会社

〒467 名古屋市瑞穂区妙音通 1-32
TEL (052) 824-2392代

BROTHER INDUSTRIES, LTD. NAGOYA, JAPAN

118-438
195438-401 ①
1990, 09

Printed in Japan/Gedruckt in Japan/Imprimé au Japon/Impreso en Japón