

DH4-B980

パーツブック
PARTS BOOK
TEILEKATALOG
LIVRE DES PIECES
LIBRO DE REFERENCIA DE PIEZAS

電子鳩目穴かがりミシン

ELECTRONIC EYELET BUTTON HOLER

ELEKTRONISCHE KNOPFLOCHNÄHMASCHINE

MACHINE ÉLECTRONIQUE POUR BOUTONNIÈRES À OEILLETS

MÁQUINA DE HACER OJALES ELECTRÓNICA

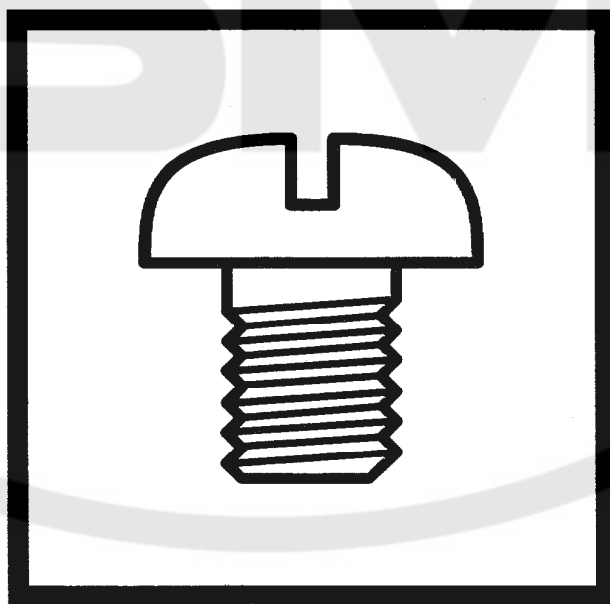

P980101

brother®

Notes sur l'utilisation de ce manuel de pièces détachées

1. Ce manuel est destiné aux machines à coudre ayant le même numéro de plaque montré sur la couverture de ce manuel (ou sur la feuille de corrections).
2. Ce manuel a été fait d'après les renseignements valables au mois de Janvier 1996.
3. Les pièces peuvent être sujettes à des modifications sans préavis.
4. Les pièces fournies en tant qu'assemblages complets sont encadrées avec un trait pointillé [] .
5. Si le symbole ※ se trouve dans la colonne "Parts No. (N° de pièce)" veuillez la vous référer à la liste de pièces annexe page 65.

TABLE DES MATIERES

A. Corps de la machine	1	L2. Mécanisme du boucleur pour point de chaînette double (Spécifications pour les Jeans)	37
B. Mécanisme de la barre à aiguille et releveur de fil	3	R2. Mécanisme de coupe-fil (Spécifications pour les Jeans)	37
C. Mécanisme de l'arbre supérieur .	5	S. Mécanisme de la coupe-fil supérieur	39
D. Mécanisme de zigzag	5	T. Synchronisateur	39
E. Mécanisme de balancement de la barre à aiguille	7	U. Mécanisme de la pression d'air	41
F1. Mécanisme de pied presseur	9	V. Mécanisme de l'équipement en alimentation électrique	45
F2. Mécanisme de pied presseur (Spécifications pour les Jeans)	13	W. Mécanisme de la pédale	47
G. Mécanisme de l'entraînement ..	17	X1. Mécanisme du moteur	47
H. Mécanisme de la coupe	21	X2. Mécanisme du moteur	49
J. Mécanisme de la poulie de tension	23	Y. Mécanisme du boîtier de contrôle	53
K. Mécanisme de l'arbre inférieur .	23	Z. Accessoires	55
L1. Mécanisme du boucleur pour point de chaînette double	25	a. Jeu d'accessoires	57
M. Mécanisme des griffes	29	b. Jeu d'accessoires	61
N. Mécanisme de l'étendeur	29	c. Jeu d'accessoires	63
P. Lubrification	31	LISTE DES PIÈCES ACCESSOIRES	65
Q. Mécanisme de l'enfilage	33	INDEX	67
R1. Mécanisme de coupe-fil	35		

A. 主体関係 / Machine body / Maschinengehäuse / Corps de la machine / Cuerpo de la máquina

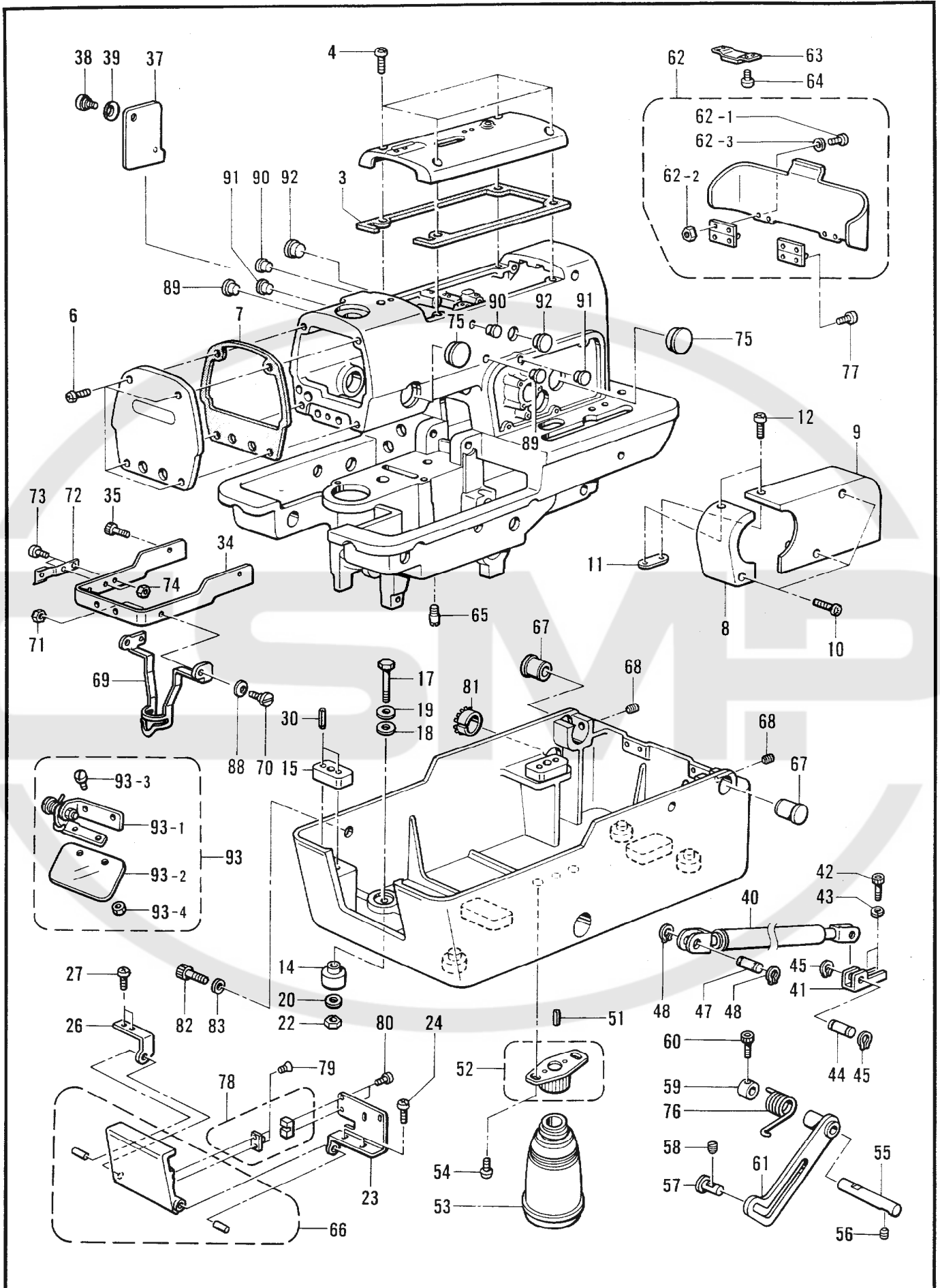

118-980-050

A. 主体関係 / Machine body / Maschinengehäuse / Corps de la machine / Cuerpo de la máquina

REF.NO.	CODE	Q'TY	ヒンメイ	NAME OF PARTS	RM
3	S35231000	1	ウワフタバツキン	TOP COVER PACKING	
4	062501202	4	ナベコM5X12	SCREW, PAN M5X12	
6	062500804	4	ナベコ5X8	SCREW, PAN M5X8	
7	S35229000	1	メンイタバツキン	FACE PLATE PACKING	
8	S35227009	1	ベルトカバーF	BELT COVER (F)	
9	S35228009	1	ベルトカバーR	BELT COVER (R)	
10	062501202	3	ナベコM5X12	SCREW, PAN M5X12	
11	S35226001	1	ベルトカバーササエ	BELT COVER SUPPORT	
12	062400812	2	ナベコ4X8	SCREW, PAN M4X8	
14	158827009	4	ベッドダイクツシヨナ	BED BASE CUSHION (A)	
15	S35225000	4	ベッドダイクツシヨナ	BED BASE CUSHION	
17	S21728001	4	ボルト6X80	BOLT, M6X80	
18	159458009	4	ゴムシート	RUBBER CUSHION	
19	115947001	4	ザガネ	WASHER	
20	025060332	4	ヒラザガネダイ6	WASHER, PLAIN L 6	
22	021060102	4	ナット1シユ6	NUT, 1 M6	
23	S35203001	1	カバーササエイタR	COVER SUPPORT PLATE (R)	
24	062400812	2	ナベコ4X8	SCREW, PAN M4X8	
26	S35224001	1	カバーササエイタL	COVER SUPPORT PLATE (L)	
27	062400812	2	ナベコ4X8	SCREW, PAN M4X8	
30	047502242	8	スプリングピンAW5	PIN, SPRING ROLL AW5	
34	S35223001	1	ハリカイドウカバー	DRIVING NEEDLE GUARD COVER	
35	018400832	4	アナボルト4X8	BOLT, SOCKET M4X8	
37	S35222001	1	ハリフリマドフタ	ZIGZAG WINDOW COVER	
38	S35221001	1	ダンネジM4	STUD SCREW, M4	
39	107017002	1	ナミバネザガネ	WASHER, WAVE SPRING	
40	S35201000	1	ガススプリング	GS SPRING	
41	S35220001	1	GSササエイタ	GS SUPPORT PLATE	
42	018501222	2	アナボルト5X12	BOLT, SOCKET M5X12	
43	028050242	2	バネザガネ2-5	WASHER, SPRING 2-5	
44	S35219001	1	GSササエピンR	GS SUPPORT PIN (R)	
45	048080142	2	トメワジクヨウC8	RETAINING RING, C8	
47	S35218001	1	GSササエピンF	GS SUPPORT PIN (F)	
48	048080142	2	トメワジクヨウC8	RETAINING RING, C8	
51	047502242	1	スプリングピンAW5	PIN, SPRING ROLL AW5	
52	154465001	1	ハイユキヤツプササエクミ	DUST OILER SUPPORT ASSY	
53	114486002	1	ポリオイラタイ	OILER	
54	062500812	2	ナベコ5X8	SCREW, PAN M5X8	
55	S35217001	1	ヒンジレバーササエジク	HINGE LEVER SUPPORT SHAFT	
56	014060632	1	アナトメ6X6クボミ	SET SCREW, SOCKET (CP) M6X6	
57	S35216001	1	ヒンジレバーシテンジク	HINGE LEVER SHAFT	
58	014060632	1	アナトメ6X6クボミ	SET SCREW, SOCKET (CP) M6X6	
59	S35215001	1	セツトカラー	SET COLLAR	
60	018061236	1	アナボルト6X12	BOLT, SOCKET M6X12	
61	S17965001	1	トウブササエレバー	HEAD SUPPORT LEVER	
62	S35214009	1	ベッドダイカバークミ	BED BASE COVER ASSY	
62-1	008300604	4	+トラスコ3X6	SCREW, TRUSS M3X6	
62-2	021300206	4	2シユナツト3	NUT, 2 M3	
62-3	025030232	4	ヒラザガネチユウ3	WASHER, PLAIN M 3	
63	S35212000	1	マグネットキヤツチ	MAGNET CATCH	
64	062300512	2	ナベコ3X5	SCREW, PAN M3X5	
65	S35208001	1	トウブアンナイピン	HEAD GUIDE PIN	
66	S35211009	1	マエカバークミ	FRONT COVER ASSY	
67	S35207001	2	ヒンジB	HINGE (B)	
68	014060632	2	アナトメ6X6クボミ	SET SCREW, SOCKET (CP) M6X6	
69	S35206101	1	フィンガーガード	FINGER GUARD	
70	S35221001	2	ダンネジM4	STUD SCREW, M4	
71	021400202	2	2シユナツト4	NUT, 2 M4	
72	S35205001	1	アイガードトメイタバネ	EYE GUARD SPRING	
73	060300616	2	バインド3X6	SCREW, BIND M3X6	
74	021300205	2	2シユナツト3	NUT, 2 M3	
75	150607009	2	ゴムセン32.8	CAP	
76	S35204001	1	ベッドヒンジバネ	BED HINGE SPRING	
77	062300512	4	ナベコ3X5	SCREW, PAN M3X5	
78	S33899000	1	ボールキヤツチクミ	BALL CATCH ASSY	
79	004300513	2	+サラコ3X5	SCREW, FLAT M3X5	
80	062300616	2	ナベコM3X6	SCREW, PAN M3X6	
81	S35202000	1	ジザイブツシユ	FREE BUSH	
82	018082036	1	アナボルト8X20	BOLT, SOCKET M8X16	
83	025080132	1	ヒラザガネシヨウ8	WASHER, PLAIN S 8	
88	107017002	2	ナミバネザガネ	WASHER, WAVE SPRING	
89	117936009	2	ゴムセン9.4	CAP	
90	158437009	2	ゴムセン10	CAP	
91	S32264009	2	ゴムセン11.5	CAP	
92	150756009	2	ゴムセン18.5	CAP	
93	S37084001	1	アイガードクミ	EYE GUARD ASSY	
93-1	S37085001	1	アイガードトリツケイタクミ	EYE GUARD SET PLATE ASSY	
93-2	153098000	1	アイガード	EYE GUARD	
93-3	100257010	2	シメネジ3.57	SCREW 3.57	
93-4	106129002	2	ナット3.57	NUT 3.57	

B. 針棒·天秤關係 / Needle bar and thread take-up mechanism / Nadelstange und Fadenabnahmevorrichtung / Mécanisme de la barre à aiguille et releveur de fil / Mecanismo de la barra de aguja y tirahilos

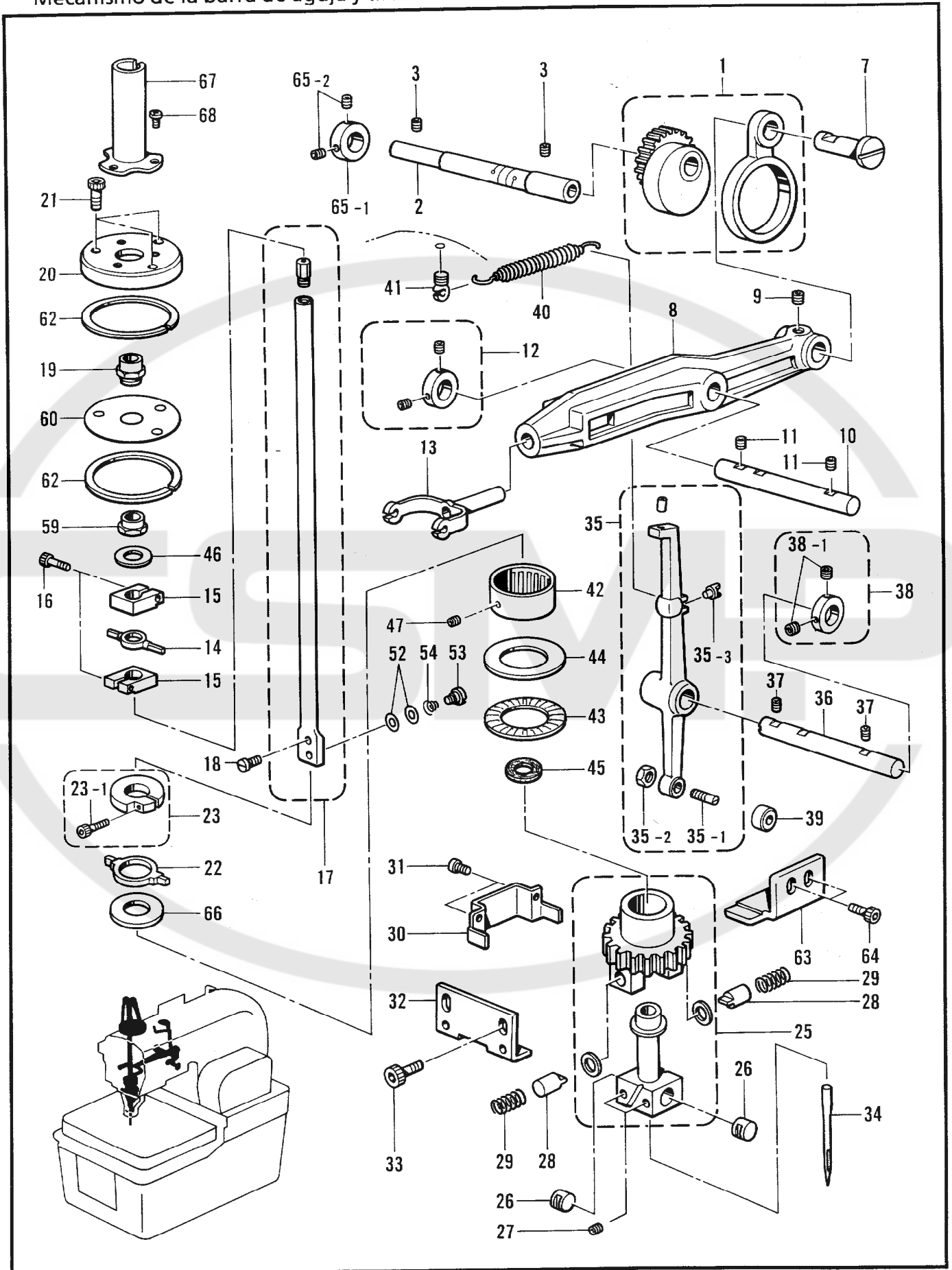

B. 針棒・天秤関係 / Needle bar and thread take-up mechanism / Nadelstange und Fadenabnahmevorrichtung / Mécanisme de la barre à aiguille et releveur de fil / Mecanismo de la barra de aguja y tirahilos

REF.NO.	CODE	Q'TY	ヒンメイ	NAME OF PARTS	RM
1	S35346001	1	クドウロツドクミ	DRIVING ROD ASSY	
2	S35339001	1	ハリクドウギヤジク	DRIVING GEAR SHAFT	
3	014060632	2	アナトメ6X6クボミ	SET SCREW, SOCKET (CP) M6X6	
7	S35340001	1	クドウロツドピン	DRIVING ROD PIN	
8	S35337001	1	ハリボウクドウレバー	NEEDLE BAR DRIVING LEVER	
9	014060632	1	アナトメ6X6クボミ	SET SCREW, SOCKET (CP) M6X6	
10	S35338001	1	ハリクドウレバージク	DRIVING LEVER SHAFT	
11	014060632	2	アナトメ6X6クボミ	SET SCREW, SOCKET (CP) M6X6	
12	S35335001	1	セツトカラークミ	SET COLLAR ASSY	
13	S35334001	1	ハリボウヨーク	NEEDLE BAR YORK	
14	S35333001	1	ハリボウスイヘイリンク	NEEDLE BAR LEVEL FEED LINK	
15	S35332001	2	ハリボウダキ	NEEDLE BAR CLAMP	
16	018301236	2	アナボルト3X12	BOLT, SOCKET M3X12	
17	S35331001	1	ハリボウクミ	NEEDLE BAR ASSY	
18	140553102	1	アタマツキトメネジ3.18	SET SCREW, M3.18	
19	S35148001	1	ハリボウメタルU	NEEDLE BAR BUSH (U)	
20	S37087001	1	ハリボウメタルオサエダイB	NEEDLE BAR PRESSER BRACKET B	
21	018402032	3	アナボルト4X20	BOLT, SOCKET M4X20	
22	S35144001	1	ハリボウスイヘイリンク	NEEDLE BAR LEVEL FEED LINK	
23	S37432001	1	ハリボウブロツクダキクミ	NEEDLE BAR BLOCK CLAMP ASSY	
23-1	018301632	1	アナボルト3X16	BOLT, SOCKET M3X16	
25	S35142001	1	ハリボウブロツククミ	NEEDLE BAR BLOCK ASSY	
26	S35138001	2	ハリボウガイドカラー	NEEDLE BAR GUIDE COLLAR	
27	153675001	2	アナトメネジ4.37	SET SCREW, SOCKET M4.37	
28	S35137001	2	ハリボウガイド	NEEDLE BAR GUIDE	
29	S35136001	2	ハリボウガイドバネ	NEEDLE BAR GUIDE SPRING	
30	S35135001	1	ハリボウアンナイササエイタ	NEEDLE BAR GUIDE SUPPORT PLATE	
31	062300616	2	ナベコ3X6	SCREW, PAN M3X6	
32	S35134001	1	ハリボウギヤササエA	NEEDLE BAR GEAR SUPPORT (A)	
33	018501036	2	アナボルト5X10	BOLT, SOCKET M5X10	
35	S35132101	1	テンピンクミ	THREAD TAKE-UP ASSY	
35-1	S35129001	1	テンピンカムコロジク	THREAD TAKE-UP CAM ROLLER SHAFT	
35-2	021500303	1	ナツト3シユ5	NUT, 3 M5	
35-3	S35911101	1	テンピンバネウケ	THREAD TAKE-UP SPRING GUARD	
36	S35128001	1	テンピンササエジク	THREAD TAKE-UP SUPPORT SHAFT	
37	014060632	2	アナトメ6X6クボミ	SET SCREW, SOCKET (CP) M6X6	
38	S23612001	1	セツトカラークミ	SET COLLAR ASSY	
38-1	012060636	2	アナヒラ6X6	SET SCREW, SOCKET (FT) M6X6	
39	S35127001	1	テンピンカムコロ	THREAD TAKE-UP CAM ROLLER	
40	S35126001	1	テンピンバネ	THREAD TAKE-UP SPRING	
41	S35078001	1	バネカケ	SPRING HOOK	
42	S35125000	1	ジクウケ25/20	BEARING 25/20	
43	S35124000	1	スラストベアリング	THRUST BEARING	
44	S35123000	1	スラストワツシヤ	THRUST WASHER	
45	S35122000	1	ハリボウブロツクフェルト	NEEDLE BAR BLOCK FELT	
46	S35121000	1	ハリボウフェルト	NEEDLE BAR FELT	
47	014300532	1	アナクボミ3X5	SET SCREW, SOCKET (CP) M3X5	
52	S35120001	2	ハライトアンナイサラ	THREAD GUIDE DISC	
53	S35119001	1	ハライトダンネジ3.18	STUD SCREW, M3.18	
54	S35118001	1	ハライトチヨウシバネ	TENSION SPRING	
59	S35117001	1	ハリボウメタルUナツト	NUT, NEEDLE BAR BUSH (U)	
60	S35116001	1	ハリボウメタルUイタバネ	SPRING, NEEDLE BAR BUSH (U)	
62	S35115001	2	ハリボウメタルUリング	RING, NEEDLE BAR BUSH (U)	
63	S35114001	1	ハリボウギヤササエB	NEEDLE BAR GEAR SUPPORT (B)	
64	018400832	2	アナボルト4X8	BOLT, SOCKET M4X8	
65-1	S17608009	1	セツトカラー	SET COLLAR	
65-2	014060622	2	アナトメネジ6X6クボミ	SET SCREW, SOCKET (CP) M6X6	
66	S35113001	1	ハリボウブロツクカラー	NEEDLE BAR BLOCK COLLAR	
67	S37088001	1	ハリボウガード	NEEDLE BAR GUARD	
68	062300512	3	ナベコ3X5	SCREW, PAN M3X5	
34	S35133016	1	ミシンハリDOX558 (#16) <-00>	NEEDLE DOX558 (#16) <-00>	
34	S35133014	1	ミシンハリDOX558 (#14) <-01>	NEEDLE DOX558 (#14) <-01>	
34	S35133018	1	ミシンハリDOX558 (#18)	NEEDLE DOX558 (#18)	

C. 上軸関係 / Upper shaft mechanism / Obere Welle /
 Mécanisme de l'arbre supérieur / Mecanismo del eje superior

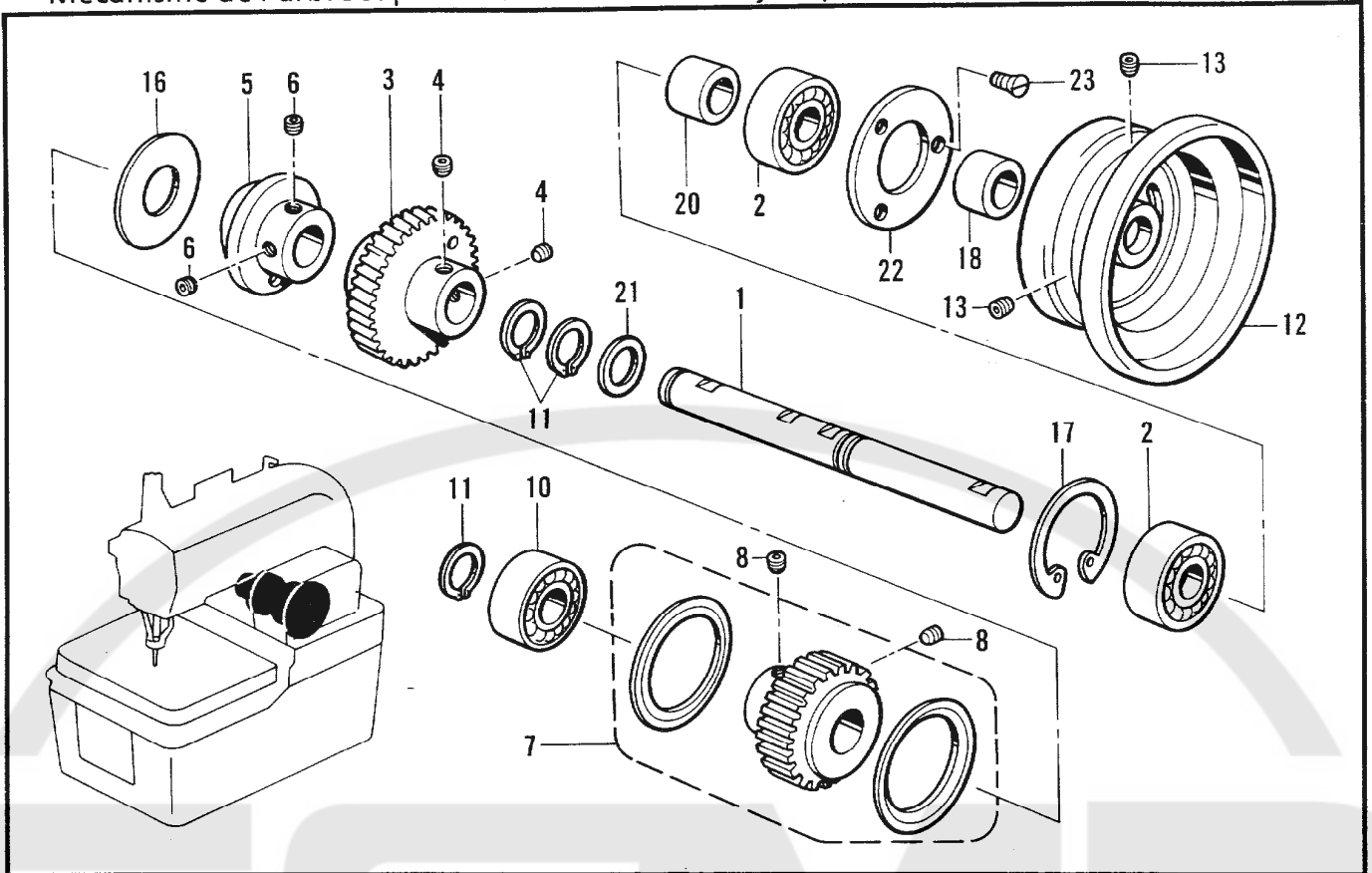

118-980-109

D. 針振関係 / Zigzag mechanism / Zickzackvorrichtung /
 Mécanisme de zigzag / Mecanismo del zigzag

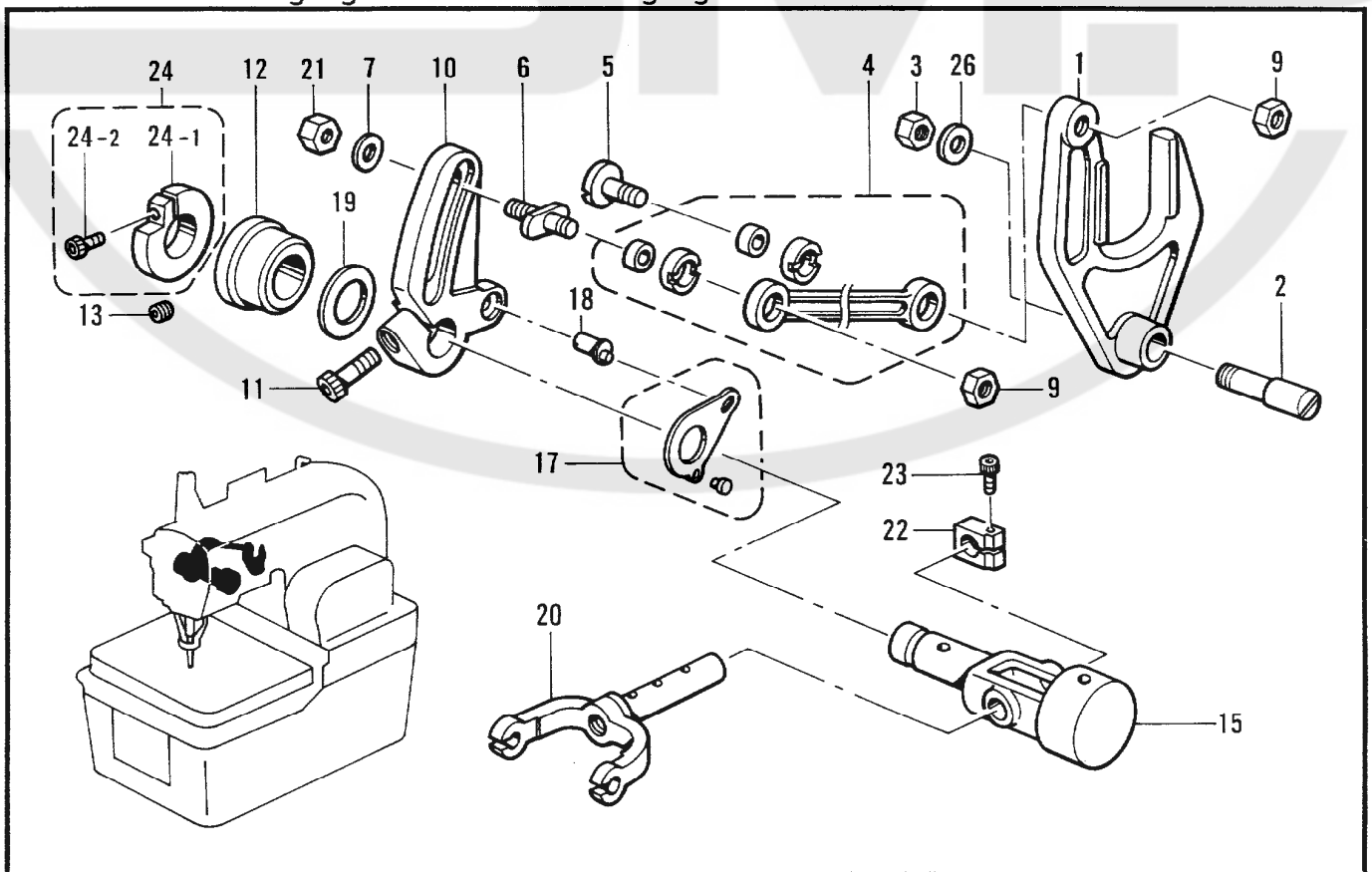

118-980-110

C. 上軸関係 / Upper shaft mechanism / Obere Welle /
Mécanisme de l'arbre supérieur / Mecanismo del eje superior

REF.NO.	CODE	Q'TY	ヒンメイ	NAME OF PARTS	RM
1	S35248001	1	ウワジク	UPPER SHAFT	
2	072620260	2	タマジクウケ6202VVC2	BALL BEARING 6202VVC2	
3	S35247001	1	ハリボウギヤ	NEEDLE BAR GEAR	
4	S23651001	2	アナヒラ6X6ホソメ	SET SCREW, SOCKET (FT) M6X6	
5	S35246001	1	ハリフリカム	ZIGZAG CAM	
6	S23651001	2	アナヒラ6X6ホソメ	SET SCREW, SOCKET (FT) M6X6	
7	S35245001	1	ウワジクTプーリクミ	UPPER SHAFT TENSION PULLEY ASSY	
8	S23651001	2	アナヒラ6X6ホソメ	SET SCREW, SOCKET (FT) M6X6	
10	076002450	1	タマジクウケ6002DD	BALL BEARING, 6002DD	
11	048150142	3	トメワジクヨウC15	RETAINING RING, C15	
12	S35242009	1	プーリ	PULLEY	
13	014060632	2	アナトメ6X6クボミ	SET SCREW, SOCKET (CP) M6X6	
16	S35249001	1	スラストザガネ	THRUST WASHER	
17	048350242	1	トメワアナヨウC35	RETAINING RING, C35	
18	S35241000	1	ウワジクプーリカラー	UPPER SHAFT PULLEY COLLAR	
20	151998000	1	ベアリングカンザ	BEARING COLLAR	
21	116920001	1	オクリジクスラストリング	THRUST RING	
22	141276001	1	タマジクウケフタS	BALL BEARING CAP (S)	
23	102843004	3	サラネジ3.57	SCREW, FLAT M3.57	

118-980-109

D. 針振関係 / Zigzag mechanism / Zickzackvorrichtung /
Mécanisme de zigzag / Mecanismo del zigzag

REF.NO.	CODE	Q'TY	ヒンメイ	NAME OF PARTS	RM
1	S35264001	1	ハリフリフタマタ	ZIGZAG FORK	
2	S35263101	1	ハリフリフタマタササエピン	ZIGZAG FORK SUPPORT PIN	
3	021080306	1	ナツト3シユ8	NUT, 3 M8	
4	S35262001	1	ハリフリレンカンクミ	ZIGZAG CONNECTING ROD ASSY	
5	S35260001	1	ダンネジM6	STUD SCREW, M6	
6	S35259001	1	ハリフリクランクダンネジ	STUD SCREW, ZIGZAG CRANK	
7	155559001	1	ヒラザガネ	WASHER, PLAIN	
9	021060102	2	ナツト1シユ6	NUT, 1 M6	
10	S35258001	1	ハリフリクランク	ZIGZAG CRANK	
11	018062022	1	アナボルト6X20	BOLT, SOCKET M6X20	
12	S35257000	1	クランクジクメタル	CRANK SHAFT BUSH	
13	014060632	1	アナトメ6X6クボミ	SET SCREW, SOCKET (CP) M6X6	
15	S35256001	1	ハリフリヨウドウジク	ZIGZAG ROCK SHAFT	
17	S35255001	1	ハリイチチヨウセツイタクミ	NEEDLE POSITION CONTROL PLATE ASSY	
18	S35252001	1	ハリフリヘンシンピン	ZIGZAG ECCENTRIC PIN	
19	148727001	1	スパーサー0.6	SPACER, 0.6	
20	S35250001	1	ハリフリウデ	ZIGZAG LEVER	
21	S35251001	1	ナツト6	NUT, M6	
22	S35332001	1	ハリボウダキ	NEEDLE BAR CLAMP	
23	018301236	1	アナボルト3X12	BOLT, SOCKET M3X12	
24	S37432001	1	ハリボウブロックダキクミ	NEEDLE BAR BLOCK CLAMP ASSY	
24-1	S35143001	1	ハリボウブロックダキ	NEEDLE BAR BLOCK CLAMP	
24-2	018301632	1	アナボルト3X16	BOLT, SOCKET M3X16	
26	153596001	1	ザガネ	WASHER	

118-980-110

E. 針棒搖動關係 / Needle bar rocking mechanism / Nadelstangenbetätigung / Mécanisme de balancement de la barre à aiguille / Mecanismo de oscilación de la barra de aguja

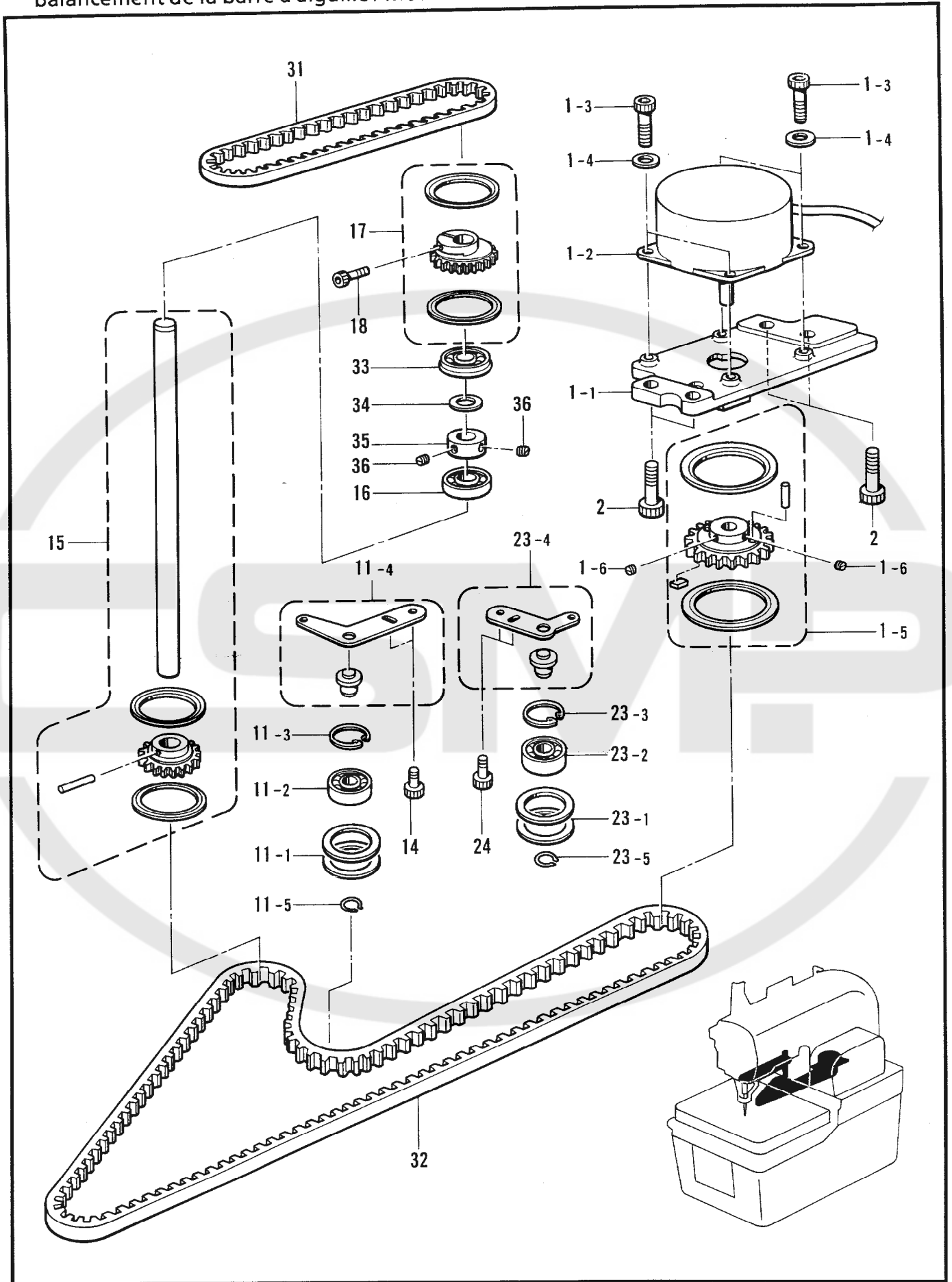

118-980-115

E. 針棒揺動関係 / Needle bar rocking mechanism / Nadelstangenbetätigung / Mécanisme de balancement de la barre à aiguille / Mecanismo de oscilación de la barra de aguja

REF.NO.	CODE	Q'TY	ヒンメイ	NAME OF PARTS	RM
1	S35278001	1	モータベースクミ	MOTOR BASE ASSY	
1-1	S35276001	1	モータベース	MOTOR BASE	
1-2	S35277000	1	パルスモータR	PULSE MOTOR (R)	
1-3	018501422	4	アナボルト5X14	BOLT, SOCKET M5X14	
1-4	025050232	4	ヒラザガネチユウ5	WASHER, PLAIN M 5	
1-5	S35283001	1	ハリカイドウプーリクミ	DRIVING NEEDLE PULLEY ASSY	
1-6	014060632	2	アナトメ6X6クボミ	SET SCREW, SOCKET (CP) M6X6	
2	018061622	4	アナボルト6X16	BOLT, SOCKET M6X16	
11	S35291001	1	テンションプーリDクミ	TENSION PULLEY (D) ASSY	
11-1	S35284001	1	テンションプーリ	TENSION PULLEY	
11-2	076000800	1	タマジクウケ6000ZZ	BALL BEARING, 6000ZZ	
11-3	048260242	2	トメワアナヨウC26	RETAINING RING, C26	
11-4	S35290001	1	テンションプーリウデDクミ	TENSION PULLEY ARM (D) ASSY	
11-5	048100142	1	トメワジクヨウC10	RETAINING RING, C10	
14	018400832	2	アナボルト4X8	BOLT, SOCKET M4X8	
15	S35296001	1	レースカイドウジククミ	DRIVING LOOPER SHAFT ASSY	
16	072620180	1	タマジクウケ6201ZZ	BALL BEARING, 6201ZZ	
17	S35297000	1	タテジクTプーリUクミ	VERTICAL SHAFT (T) PULLEY (U) ASSY	
18	018401636	1	アナボルト4X16	BOLT, SOCKET M4X16	
23	S35288001	1	テンションプーリUクミ	TENSION PULLEY (U) ASSY	
23-1	S35284001	1	テンションプーリ	TENSION PULLEY	
23-2	076000800	1	タマジクウケ6000ZZ	BALL BEARING, 6000ZZ	
23-3	048260242	1	トメワアナヨウC26	RETAINING RING, C26	
23-4	S35287001	1	テンションプーリウデUクミ	TENSION PULLEY ARM (U) ASSY	
23-5	048100142	1	トメワジクヨウC10	RETAINING RING, C10	
24	018400832	2	アナボルト4X8	BOLT, SOCKET M4X8	
31	S35300000	1	タイミングベルトU	TIMING BELT (U)	
32	S35299000	1	タイミングベルトD	TIMING BELT (D)	
33	076001850	1	タマジクウケ6001ZZ	BALL BEARING, 6001ZZ	
34	142627001	1	ザガネ	WASHER	
35	S35302001	1	セットカラー	SET COLLAR	
36	014060632	2	アナトメ6X6クボミ	SET SCREW, SOCKET (CP) M6X6	

F1. 押工関係 / Presser foot mechanism / Stoffdrückerfuß /
 Mécanisme de pied presseur / Mecanismo de la prensa tela

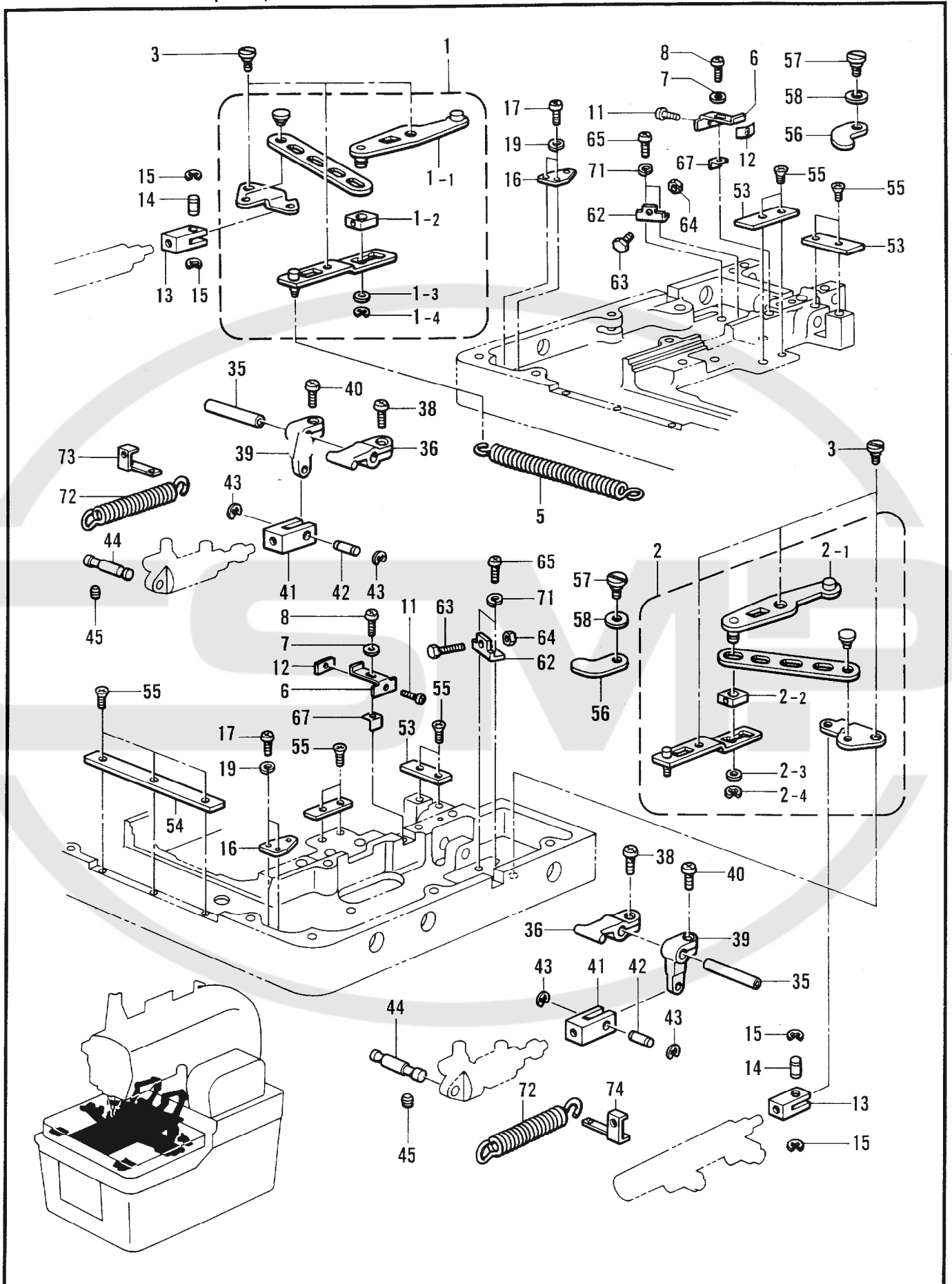

118-980-201

F1. 押工関係 / Presser foot mechanism / Stoffdrückerfuß /
 Mécanisme de pied presseur / Mecanismo de la prensa tela

REF.NO.	CODE	Q'TY	ヒンメイ	NAME OF PARTS	RM
1	S34957001	1	ヒラキレンカンLクミ	OPENING CONNECTING ROD (L) ASSY	
1-1	S34965001	1	シテンレバープレートL	FULCRUM LEVER PLATE (L)	
1-2	102630001	1	ハリボウアンナイカクコマ	NEEDLE BAR GUIDE SLIDE BLOCK	
1-3	109763002	1	ザガネ	WASHER	
1-4	048050342	1	トメワE5	RETAINING RING, E5	
2	S34963001	1	ヒラキレンカンRクミ	OPENING CONNECTING ROD (R) ASSY	
2-1	S34964001	1	シテンレバープレートR	FULCRUM LEVER PLATE (R)	
2-2	102630001	1	ハリボウアンナイカクコマ	NEEDLE BAR GUIDE SLIDE BLOCK	
2-3	109763002	1	ザガネ	WASHER	
2-4	048050342	1	トメワE5	RETAINING RING, E5	
3	S34966001	6	ダンネジM4	STUD SCREW, M4	
5	S35429001	1	ヒラキバネ	OPENING SPRING	
6	S34967001	2	ヒラキストツパイタ	OPENING STOPPER PLATE	
7	025040232	2	ヒラザガネチユウ4	WASHER, PLAIN M 4	
8	062400812	2	ナベコ4X8	SCREW, PAN M4X8	
11	062301016	2	ナベコM3X10	SCREW, PAN M3X10	
12	S34968000	2	スピードナツトM3	SPEED NUT, M3	
13	S34970001	2	ヒラキシリンダロツド	OPENING CYLINDER ROD	
14	S34969001	2	シリンダロツドピンB	CYLINDER ROD PIN (B)	
15	048030342	4	トメワE3	RETAINING RING, E3	
16	S35169001	2	ヒラキシリンダササエ	OPENING CYLINDER SUPPORT	
17	062400812	4	ナベコ4X8	SCREW, PAN M4X8	
19	028040242	4	バネザガネ2-4	WASHER, SPRING 2-4	
35	S35239001	2	クランプレバージク	CLAMP LEVER SHAFT	
36	S35240001	2	クランプレバーB	CLAMP LEVER (B)	
38	062501202	2	ナベコM5X12	SCREW, PAN M5X12	
39	S35303101	2	オサエクドウレバー	PRESSER DRIVING LEVER	
40	062501202	2	ナベコM5X12	SCREW, PAN M5X12	
41	S35166001	2	オサエシリンダロツド	PRESSER CYLINDER ROD	
42	S35305001	2	シリンダロツドピン	CYLINDER ROD PIN	
43	048030342	4	トメワE3	RETAINING RING, E3	
44	S35304001	2	クランプシリンダササエ	CLAMP CYLINDER SUPPORT	
45	014400532	2	アナクボミ4X5	SET SCREW, SOCKET (CP) M4X5	
53	S35321001	4	プレートガイドイタA	PLATE GUIDE (A)	
54	S35322001	1	プレートガイドイタB	PLATE GUIDE (B)	
55	S06696004	11	サラコネジ3X6	SCREW, FLAT M3X6	
56	S35323001	2	プレートオサエ	PLATE PRESSER	
57	S35324001	2	ダンネジM4	STUD SCREW, M4	
58	S36345000	2	マゲワッシャー	WASHER, SPRING	
62	S35327001	2	ヒラキシリンダストツバ	OPENING CYLINDER STOPPER	
63	017401415	2	ボルト4X14	BOLT, M4X14	
64	021400202	2	2シユナツト4	NUT, 2 M4	
65	062400812	4	ナベコ4X8	SCREW, PAN M4X8	
67	S35328001	2	ヒラキストツバアテイタ	OPENING STOPPER PLATE	
71	028040242	4	バネザガネ2-4	WASHER, SPRING 2-4	
72	S35456001	2	オサエモドシバネ	PRESSER SPRING	
73	S35457001	1	バネカケL	SPRING HOOK (L)	
74	S35458001	1	バネカケR	SPRING HOOK (R)	

F1. 押工関係 / Presser foot mechanism / Stoffdrückerfuß /
 Mécanisme de pied presseur / Mecanismo de la prensa tela

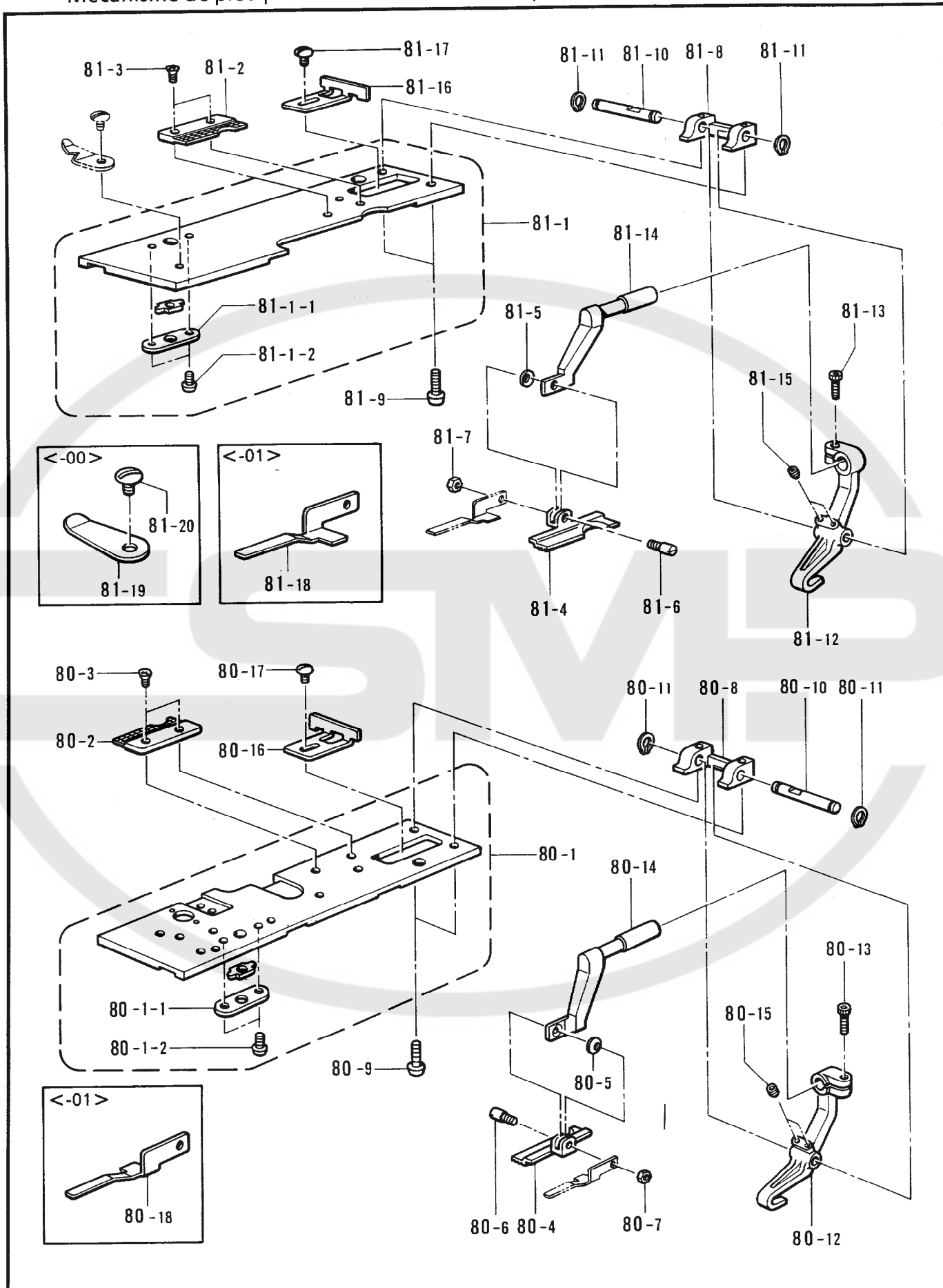

F1. 押工関係 / Presser foot mechanism / Stoffdrückerfuß /
 Mécanisme de pied presseur / Mecanismo de la prensa tela

REF.NO.	CODE	Q'TY	ヒンメイ	NAME OF PARTS	RM
<-00><上糸切り用/ FOR UPPER THREAD TRIMMER>					
81	S35475201	1	オサエプレートLソウクミ	CLOTH PRESSER PLATE (L) SET	
81-1	S35310001	1	ヌノオサエプレートLクミ	CLOTH PRESSER PLATE (L) ASSY	
81-2	S37683101	1	ハリイタL-50	NEEDLE PLATE (L-50)	※
81-4	S37679001	1	ヌノオサエL-50	CLOTH PRESSER (L-50)	※
81-19	S38335000	1	イトホジイタ	THREAD GUIDE PLATE	
81-20	S35326001	1	シメネジM3.5	SCREW, M3.5	
<-01><上下糸切り用/ FOR UPPER AND LOWER THREAD TRIMMER>					
81	S35476301	1	オサエプレートLSソウクミ	CLOTH PRESSER PLATE (LS) SET	
81-1	S35317001	1	ヌノオサエプレートLSクミ	CLOTH PRESSER PLATE (LS) ASSY	
81-2	S35308101	1	ハリイタL	NEEDLE PLATE (L)	※
81-4	S35453001	1	ヌノオサエLL	CLOTH PRESSER (LL)	※
81-18	S35329001	1	キジオサエイタL	CLOTH PRESSER PLATE (L)	
81-1-1	S35316001	1	カクコマササエイタ	SLIDE BLOCK SUPPORT PLATE	
81-1-2	060020416	2	バインドM2X4	SCREW, BIND M2X4	
81-3	S06696004	2	サラコネジ3X6	SCREW, FLAT M3X6	
81-5	S35236000	1	マゲザガネ3.2	BENDING WASHER, M3.2	
81-6	S35235001	1	クランプササエピン	CLAMP SUPPORT PIN	
81-7	021300302	1	3シユナツト3	NUT, 3 M3	
81-8	S35238001	1	クランプジクウケ	CLAMP SHAFT HOLDER	
81-9	062401016	2	ナベコ4X10	SCREW, PAN M4X10	
81-10	S35237001	1	クランプシテンジク	CLAMP FULCRUM SHAFT	
81-11	048050142	2	トメワジクヨウC5	RETAINING RING, C5	
81-12	S35233101	1	クランプレバーL	CLAMP LEVER (L)	
81-13	018501236	1	アナボルト5X12	BOLT, SOCKET M5X12	
81-14	S35168001	1	クランプアームL	CLAMP ARM (L)	
81-15	014400532	2	アナクボミ4X5	SET SCREW, SOCKET (CP) M4X5	
81-16	S35348000	1	ヌノガイドL	CLOTH GUIDE (L)	
81-17	S35326001	1	シメネジM3.5	SCREW, M3.5	
<-00><上糸切り用/ FOR UPPER THREAD TRIMMER>					
80	S35474201	1	オサエプレートRソウクミ	CLOTH PRESSER PLATE (R) SET	
80-1	S35318001	1	ヌノオサエプレートRクミ	CLOTH PRESSER PLATE (R) ASSY	
80-2	S37684101	1	ハリイタR-50	NEEDLE PLATE (R-50)	※
80-4	S37680001	1	ヌノオサエRL-50	CLOTH PRESSER (RL-50)	※
<-01><上下糸切り用/ FOR UPPER AND LOWER THREAD TRIMMER>					
80	S35478301	1	オサエプレートRSソウクミ	CLOTH PRESSER PLATE (RS) SET	
80-1	S35319001	1	ヌノオサエプレートRSクミ	CLOTH PRESSER PLATE (RS) ASSY	
80-2	S35309101	1	ハリイタR	NEEDLE PLATE (R)	※
80-4	S35452001	1	ヌノオサエRL	CLOTH PRESSER (RL)	※
80-18	S35330001	1	キジオサエイタR	CLOTH PRESSER PLATE (R)	
80-1-1	S35316001	1	カクコマササエイタ	SLIDE BLOCK SUPPORT PLATE	
80-1-2	060020416	2	バインドM2X4	SCREW, BIND M2X4	
80-3	S06696004	2	サラコネジ3X6	SCREW, FLAT M3X6	
80-5	S35236000	1	マゲザガネ3.2	BENDING WASHER, M3.2	
80-6	S35235001	1	クランプササエピン	CLAMP SUPPORT PIN	
80-7	021300302	1	3シユナツト3	NUT, 3 M3	
80-8	S35238001	1	クランプジクウケ	CLAMP SHAFT HOLDER	
80-9	062401016	2	ナベコ4X10	SCREW, PAN M4X10	
80-10	S35237001	1	クランプシテンジク	CLAMP FULCRUM SHAFT	
80-11	048050142	2	トメワジクヨウC5	RETAINING RING, C5	
80-12	S35234101	1	クランプレバーR	CLAMP LEVER (R)	
80-13	018501236	1	アナボルト5X12	BOLT, SOCKET M5X12	
80-14	S35167001	1	クランプアームR	CLAMP ARM (R)	
80-15	014400532	2	アナクボミ4X5	SET SCREW, SOCKET (CP) M4X5	
80-16	S35347000	1	ヌノガイドR	CLOTH GUIDE (R)	
80-17	S35326001	1	シメネジM3.5	SCREW, M3.5	

F2. 押工関係(ジーンズ仕様) / Presser foot mechanism(Jeans specification) /
 Stoffdrückerfuß(Jeans-Ausführung) / Mécanisme de pied presseur(Spécifications pour
 les Jeans) / Mecanismo de la prensa tela(Especificación para Jeans)

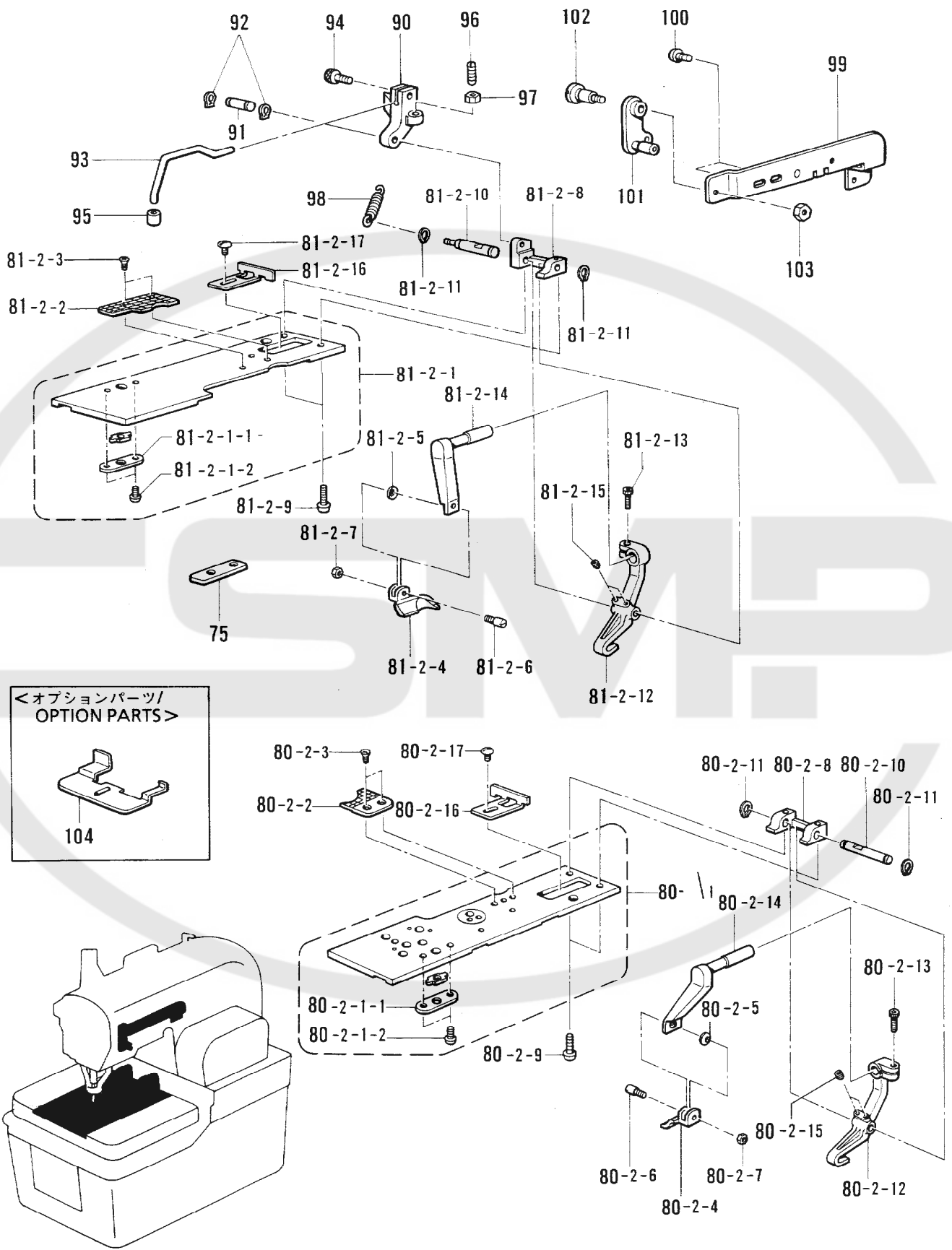

F2. 押工関係(ジーンズ仕様) / Presser foot mechanism(Jeans specification) /
 Stoffdrückerfuß(Jeans-Ausführung) / Mécanisme de pied presseur(Spécifications pour
 les Jeans) / Mecanismo de la prensa tela(Especificación para Jeans)

REF.NO.	CODE	Q'TY	ヒンメイ	NAME OF PARTS	RM
<L1 14-18mm>					
80-2	S37756201	1	オサエプレートJR1ソウクミ	CLOTH PRESSER PLATE (J)(R1) SET	※
80-2-2	S37644001	1	ハリイタL1R	NEEDLE PLATE (L1)(R)	※
80-2-4	S37754001	1	ヌノオサエR-JL1	CLOTH PRESSER (R-J)(L1)	※
<L2 18-22mm>					
80-2	S37727201	1	オサエプレートJR2ソウクミ	CLOTH PRESSER PLATE (J)(R2) SET	※
80-2-2	S37646001	1	ハリイタL2R	NEEDLE PLATE (L2)(R)	※
80-2-4	S37690001	1	ヌノオサエR-JL2	CLOTH PRESSER (R-J)(L2)	※
<L3 22-26mm>					
80-2	S37733201	1	オサエプレートJR3ソウクミ	CLOTH PRESSER PLATE (J)(R3) SET	※
80-2-2	S37648001	1	ハリイタL3R	NEEDLE PLATE (L3)(R)	※
80-2-4	S37692001	1	ヌノオサエR-JL3	CLOTH PRESSER (R-J)(L3)	※
<L4 26-30mm>					
80-2	S37757001	1	オサエプレートJR4ソウクミ	CLOTH PRESSER PLATE (J)(R4) SET	※
80-2-2	S37650001	1	ハリイタL4R	NEEDLE PLATE (L4)(R)	※
80-2-4	S37758001	1	ヌノオサエR-JL4	CLOTH PRESSER (R-J)(L4)	※
80-2-1	S37729001	1	オサエプレートJRクミ	CLOTH PRESSER PLATE (J)(R) ASSY	
80-2-1-1	S35316001	1	カクコマササエイタ	SLIDE BLOCK SUPPORT PLATE	
80-2-1-2	060020416	2	バインドM2X4	SCREW, BIND M2X4	
80-2-3	S06696004	2	サラコネジ3X6	SCREW, FLAT M3X6	
80-2-5	S35236000	1	マゲザガネ3.2	BENDING WASHER, M3.2	
80-2-6	S35235001	1	クランプササエピン	CLAMP SUPPORT PIN	
80-2-7	021300302	1	3シユナツト3	NUT, 3 M3	
80-2-8	S35238001	1	クランプジクウケ	CLAMP SHAFT HOLDER	
80-2-9	062401016	2	ナベコ4X10	SCREW, PAN M4X10	
80-2-10	S35237001	1	クランプシテンジク	CLAMP FULCRUM SHAFT	
80-2-11	048050142	2	トメワジクヨウC5	RETAINING RING, C5	
80-2-12	S35234101	1	クランプレバーR	CLAMP LEVER (R)	
80-2-13	018501236	1	アナボルト5X12	BOLT, SOCKET M5X12	
80-2-14	S37695001	1	クランプアームR-J	CLAMP ARM (R-J)	
80-2-15	014400532	2	アナクボミ4X5	SET SCREW, SOCKET (CP) M4X5	
80-2-16	S35347000	1	ヌノガイドR	CLOTH GUIDE (R)	
80-2-17	S35326001	1	シメネジM3.5	SCREW, M3.5	
<L1 14-18mm>					
81-2	S37731201	1	オサエプレートJL1ソウクミ	CLOTH PRESSER PLATE (J)(L1) SET	※
81-2-2	S37643001	1	ハリイタL1L	NEEDLE PLATE (L1)(L)	※
81-2-4	S37755001	1	ヌノオサエL-JL1	CLOTH PRESSER (L-J)(L1)	※
<L2 18-22mm>					
81-2	S37728201	1	オサエプレートJL2ソウクミ	CLOTH PRESSER PLATE (J)(L2) SET	※
81-2-2	S37645001	1	ハリイタL2L	NEEDLE PLATE (L2)(L)	※
81-2-4	S37689001	1	ヌノオサエL-JL2	CLOTH PRESSER (R-J)(L2)	※
<L3 22-26mm>					
81-2	S37735201	1	オサエプレートJL3ソウクミ	CLOTH PRESSER PLATE (J)(L3) SET	※
81-2-2	S37647001	1	ハリイタL3L	NEEDLE PLATE (L3)(L)	※
81-2-4	S37691001	1	ヌノオサエL-JL3	CLOTH PRESSER (L-J)(L3)	※
<L4 26-30mm>					
81-2	S37732201	1	オサエプレートJL4ソウクミ	CLOTH PRESSER PLATE (J)(L4) SET	※
81-2-2	S37649001	1	ハリイタL4L	NEEDLE PLATE (L4)(L)	※
81-2-4	S37759001	1	ヌノオサエL-JL4	CLOTH PRESSER (L-J)(L4)	※
81-2-1	S37730001	1	オサエプレートJLクミ	CLOTH PRESSER PLATE (J)(L) ASSY	
81-2-1-1	S35316001	1	カクコマササエイタ	SLIDE BLOCK SUPPORT PLATE	
81-2-1-2	060020416	2	バインドM2X4	SCREW, BIND M2X4	
81-2-3	S06696004	2	サラコネジ3X6	SCREW, FLAT M3X6	
81-2-5	S35236000	1	マゲザガネ3.2	BENDING WASHER, M3.2	
81-2-6	S35235001	1	クランプササエピン	CLAMP SUPPORT PIN	
81-2-7	021300302	1	3シユナツト3	NUT, 3 M3	
81-2-8	S37712001	1	クランプジクウケ	CLAMP SHAFT HOLDER	
81-2-9	062401016	2	ナベコ4X10	SCREW, PAN M4X10	
81-2-10	S37711001	1	クランプシテンジク	CLAMP FULCRUM SHAFT	
81-2-11	048050142	2	トメワジクヨウC5	RETAINING RING, C5	
81-2-12	S35233101	1	クランプレバーL	CLAMP LEVER (L)	
81-2-13	018501236	1	アナボルト5X12	BOLT, SOCKET M5X12	
81-2-14	S37694001	1	クランプアームL-J	CLAMP ARM (L-J)	
81-2-15	014400532	2	アナクボミ4X5	SET SCREW, SOCKET (CP) M4X5	
81-2-16	S35348000	1	ヌノガイドL	CLOTH GUIDE (L)	
81-2-17	S35326001	1	シメネジM3.5	SCREW, M3.5	

118-980-201

F2. 押エ関係(ジーンズ仕様) / Presser foot mechanism(Jeans specification) /
 Stoffdrückerfuß(Jeans-Ausführung) / Mécanisme de pied presseur(Spécifications pour
 les Jeans) / Mecanismo de la prensa tela(Especificación para Jeans)

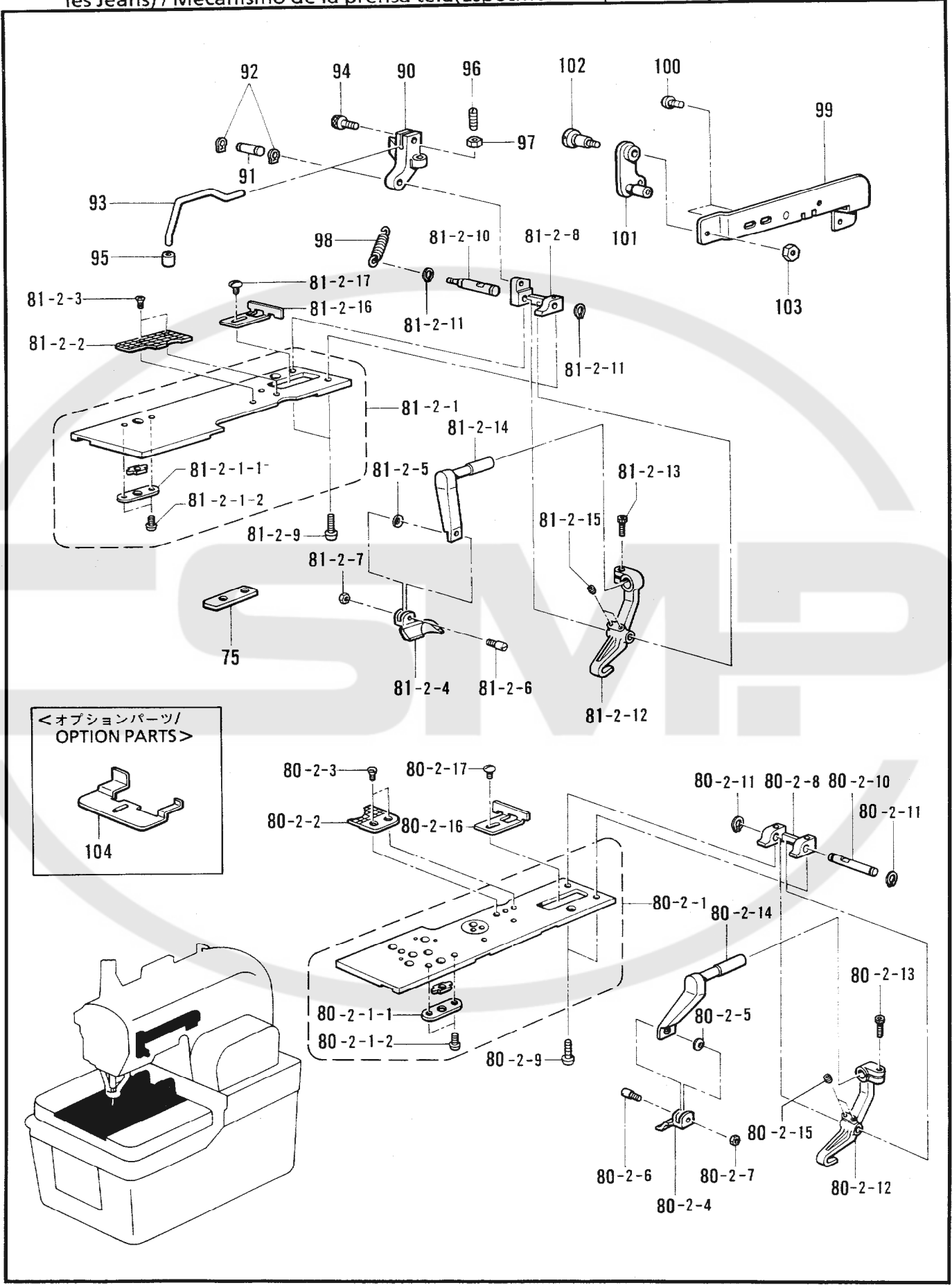

<オプションパーツ/
 OPTION PARTS>
 104

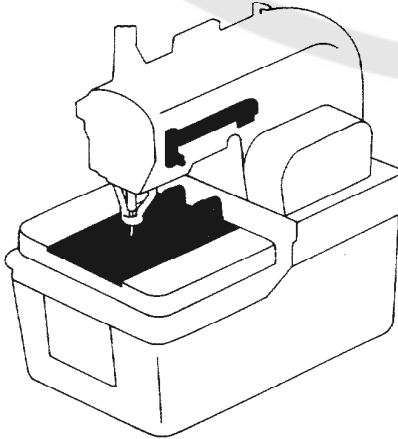

F2. 押工関係(ジーンズ仕様) / Presser foot mechanism(Jeans specification) /
 Stoffdrückerfuß(Jeans-Ausführung) / Mécanisme de pied presseur(Spécifications pour
 les Jeans) / Mecanismo de la prensa tela(Especificación para Jeans)

REF.NO.	CODE	Q'TY	ヒンメイ	NAME OF PARTS	RM
75	S37693001	1	プレートガイドイタC	PLATE GUIDE (C)	
90	S37714001	1	ホジヨオサエシテンダイ	SUB PRESSER FULCRUM BRACKET	
91	S37713001	1	ホジヨオサエシテンジク	SUB PRESSER FULCRUM SHAFT	
92	048050142	2	トメワジクヨウC5	RETAINING RING, C5	
93	S37718000	1	ホジヨオサエウデ	SUB PRESSER ARM	
94	018401032	1	アナボルト4X10	BOLT, SOCKET M4X10	
95	S05356000	1	ボタンオサエ A	BUTTON HOLDER (A)	
96	S08808001	1	ストップネジ	STOPPER SCREW	
97	021660102	1	ナット1シユ3.18	NUT, 1 M3.18	
98	S37753001	1	ホジヨオサエモドシバネ	SUB PRESSER SPRING	
99	S37744001	1	Fオサエシリンダササエクミ	SUB PRESSER SYLINDER SUPPORT ASSY	
100	062400812	2	ナベコ4X8	SCREW, PAN M4X8	
101	S37717001	1	ホジヨオサエリンククミ	SUB PRESSER LINK ASSY	
102	S34922101	1	ダンネジM4	SHOULDER SCREW, M4	
103	021400202	1	2シユナット4	NUT, 2 M4	
<オプションパーツ/OPTION PARTS>					
104	S37870000	1	ヌノガイドJ	CLOTH GUIDE (J)	

118-980-201

G. 送り関係 / Feed mechanism / Transportvorrichtung /
 Mécanisme de l'entraînement / Mecanismo de la alimentación

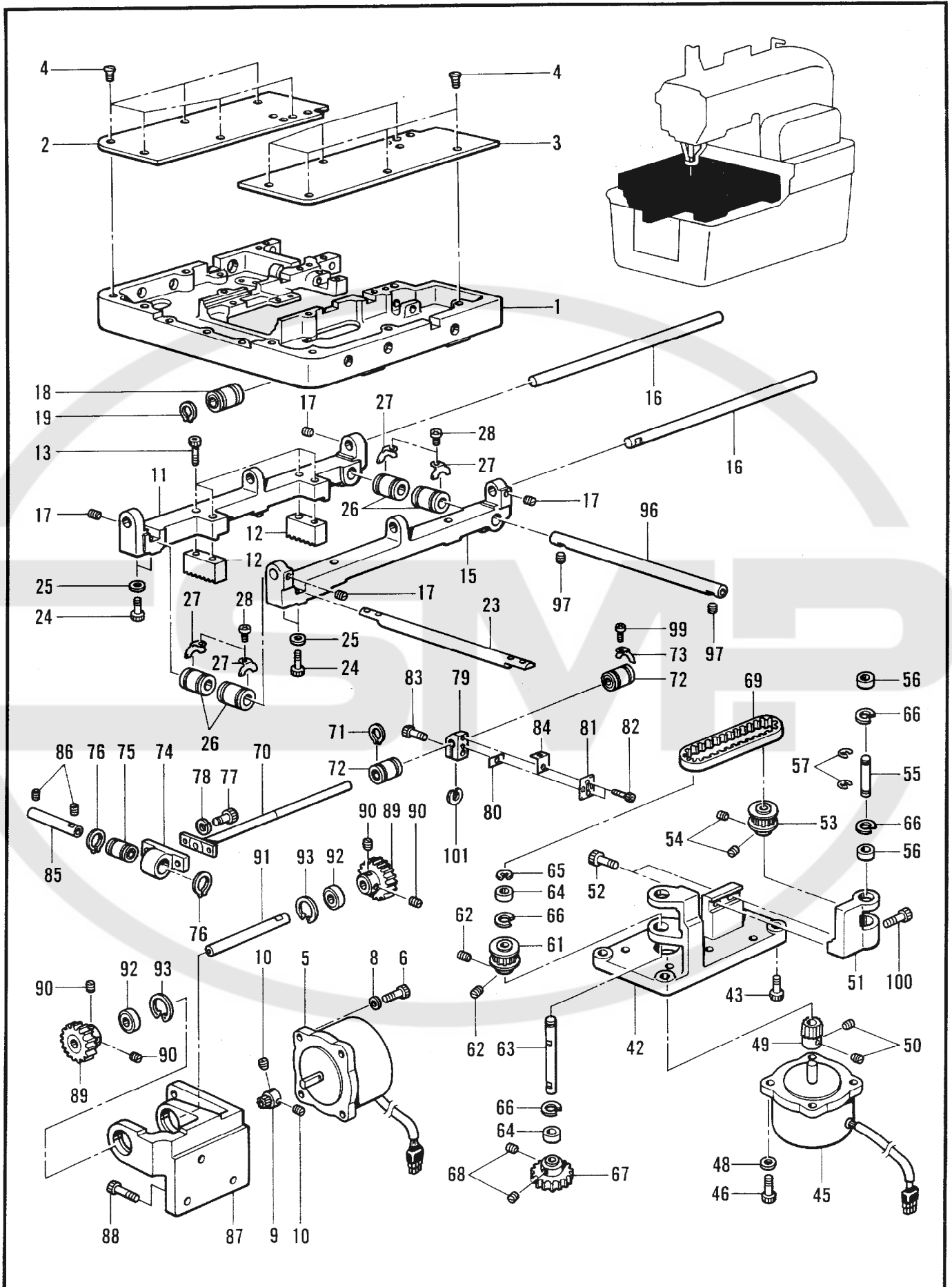

G. 送り関係 / Feed mechanism / Transportvorrichtung /
Mécanisme de l'entraînement / Mecanismo de la alimentación

REF.NO.	CODE	Q'TY	ヒンメイ	NAME OF PARTS	RM
1	S34950009	1	オクリダイ	FEED BAR	
2	S35176001	1	オクリダイカバーL	FEED BAR COVER (L)	
3	S35177001	1	オクリダイカバーR	FEED BAR COVER (R)	
4	S29410001	12	サラネジM4	SCREW, FLAT M4	
5	S35171000	1	パルスモータX	PULSE MOTOR (X)	
6	018501631	4	アナボルト5X16	BOLT, SOCKET M5X16	
8	025050232	4	ヒラザガネチユウ5	WASHER, PLAIN M 5	
9	S02403001	1	クドウギヤ	ACTUATING GEAR	
10	014760622	2	アナトメネジ5.95	SET SCREW, SOCKET (CP) M5.95	
11	S35181001	1	XオクリジクウケLクミ	X-FEED SHAFT HOLDER (L) ASSY	
12	S35178001	2	Xラツク	X-RACK	
13	018501631	4	アナボルト5X16	BOLT, SOCKET M5X16	
15	S35179000	1	XオクリジクウケR	X-FEED SHAFT HOLDER (R)	
16	S35188001	2	Yオクリアンナイジク	Y-FEED GUIDE SHAFT	
17	014060632	4	アナトメ6X6クボミ	SET SCREW, SOCKET (CP) M6X6	
18	S12004000	4	リニアブツシュ	LINEAR BUSH	
19	S02460001	8	トメワジクヨウC19	RETAINING RING, C19	
23	S35182001	1	XオクリアンナイジクA	X-FEED GUIDE SHAFT (A)	
24	018401636	4	アナボルト4X16	BOLT, SOCKET M4X16	
25	025040232	4	ヒラザガネチユウ4	WASHER, PLAIN M 4	
26	S35183000	4	リニアブツシュ12	LINEAR BUSH 12	
27	S35184001	4	タマジクウケトメイタ	BALL BEARING STOPPER	
28	062300416	4	ナベコM3X4	SCREW, PAN M3X4	
42	S35173001	1	Yオクリベース	Y-FEED BASE	
43	018061622	4	アナボルト6X16	BOLT, SOCKET M6X16	
45	S35172000	1	パルスモータY	PULSE MOTOR (Y)	
46	018501622	4	アナボルト5X16	BOLT, SOCKET M5X16	
48	025050232	4	ヒラザガネチユウ5	WASHER, PLAIN M 5	
49	S10081001	1	クドウギヤ	DRIVING GEAR	
50	014760622	2	アナトメネジ5.95	SET SCREW, SOCKET (CP) M5.95	
51	S35174001	1	YプーリササE L	Y-PULLEY SUPPORT (L)	
52	018501422	2	アナボルト5X14	BOLT, SOCKET M5X14	
53	S27844001	1	タイミングプーリア	TIMING PULLEY (A)	
54	014770622	2	アナトメネジ6.35クボミ	SET SCREW, SOCKET (CP) M6.35	
55	S35186001	1	YプーリジクL	Y-PULLEY SHAFT (L)	
56	S30138001	2	マイクロベアリング8	MICRO BEARING 8	
57	048060342	2	トメワE6	RETAINING RING, E6	
61	S27844001	1	タイミングプーリア	TIMING PULLEY (A)	
62	014770622	2	アナトメネジ6.35クボミ	SET SCREW, SOCKET (CP) M6.35	
63	S35189001	1	YプーリジクR	Y-PULLEY SHAFT (R)	
64	S30138001	2	マイクロベアリング8	MICRO BEARING 8	
65	048060342	1	トメワE6	RETAINING RING, E6	
66	048160242	4	トメワアナヨウC16	RETAINING RING, C16	
67	S10082001	1	アイドルギヤ	IDLE GEAR	
68	014760622	2	アナトメネジ5.95	SET SCREW, SOCKET (CP) M5.95	
69	S10077100	1	Yタイミングベルト	Y-TIMING BELT	
70	S35190001	1	Yジク	Y-SHAFT	
71	S02460001	2	トメワC19	RETAINING RING, C19	
72	S12004000	2	リニアブツシュ	LINEAR BUSH	
73	S35184001	1	タマジクウケトメイタ	BALL BEARING STOPPER	
74	S35191001	1	ジクウケ	BALL BEARING	
75	S12004000	1	リニアブツシュ	LINEAR BUSH	
76	S02460001	2	トメワジクヨウC19	RETAINING RING, C19	
77	018061022	2	アナボルト6X10	BOLT, SOCKET M6X10	
78	028060242	2	バネザガネ2-6	WASHER, SPRING 2-6	
79	S31568000	1	Yクドウジクホルダ	Y-DRIVING SHAFT HOLDER	
80	S10078001	1	Tベルトスペーサ	TIMING BELT SPACER	
81	S10079001	1	ベルトホルダ	BELT HOLDER	
82	018680822	2	アナボルト4.37X8	BOLT, SOCKET M4.37X8	

G. 送り関係 / Feed mechanism / Transportvorrichtung /
 Mécanisme de l'entraînement / Mecanismo de la alimentación

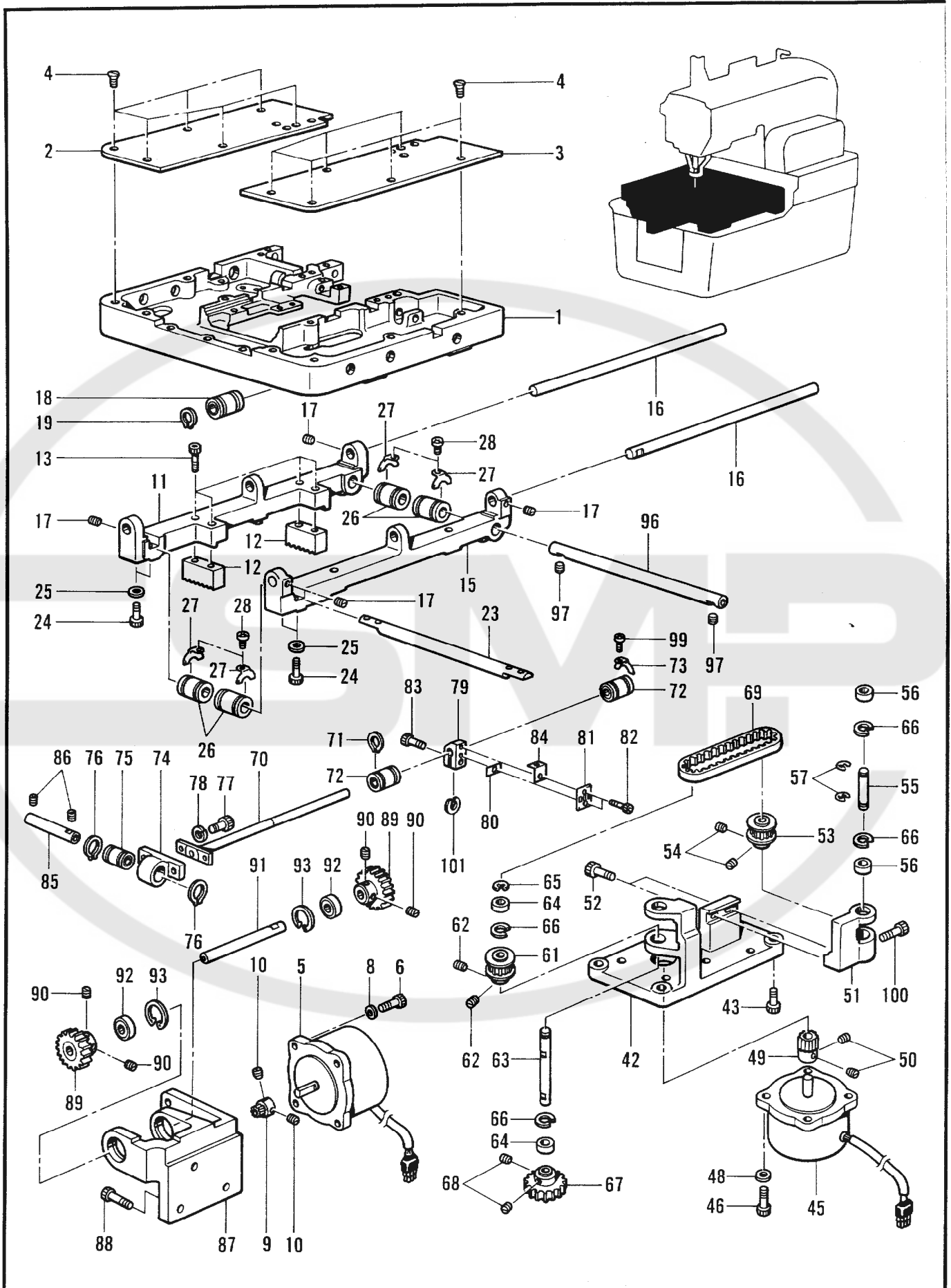

G. 送り関係 / Feed mechanism / Transportvorrichtung /
 Mécanisme de l'entraînement / Mecanismo de la alimentación

REF.NO.	CODE	Q'TY	ヒンメイ	NAME OF PARTS	RM
83	018501631	1	アナボルト5X16	BOLT, SOCKET M5X16	
84	S35192001	1	センサシキリイタクミ	SENSOR PARTITION PLATE ASSY	
85	S35194001	1	Yガイドジク	Y-GUIDE SHAFT	
86	012500536	2	アナヒラ5X5	SET SCREW, SOCKET (FT) M5X5	
87	S35175001	1	モータササエ	MOTOR SUPPORT	
88	018061622	3	アナボルト6X16	BOLT, SOCKET M6X16	
89	S35196100	2	アイドルギヤ	IDLE GEAR	
90	014060632	4	アナトメ6X6クボミ	SET SCREW, SOCKET (CP) M6X6	
91	S35195001	1	アイドルギヤジク	IDLE GEAR SHAFT	
92	076001800	2	タマジクウケ6001ZZ	BALL BEARING, 6001ZZ	
93	048280242	2	トメワアナヨウC28	RETAINING RING, C28	
96	S35187001	1	XオクリアンナイジクB	X-FEED GUIDE SHAFT (B)	
97	014060632	2	アナトメ6X6クボミ	SET SCREW, SOCKET (CP) M6X6	
99	062300416	1	ナベコM3X4	SCREW, PAN M3X4	
100	018502022	1	アナボルト5X20	BOLT, SOCKET M5X20	
101	148782001	1	スペーサ	SPACER	

H. カッター関係 / Cutter mechanism / Abschneidevorrichtung /
 Mécanisme de la coupe / Mecanismo de la corta

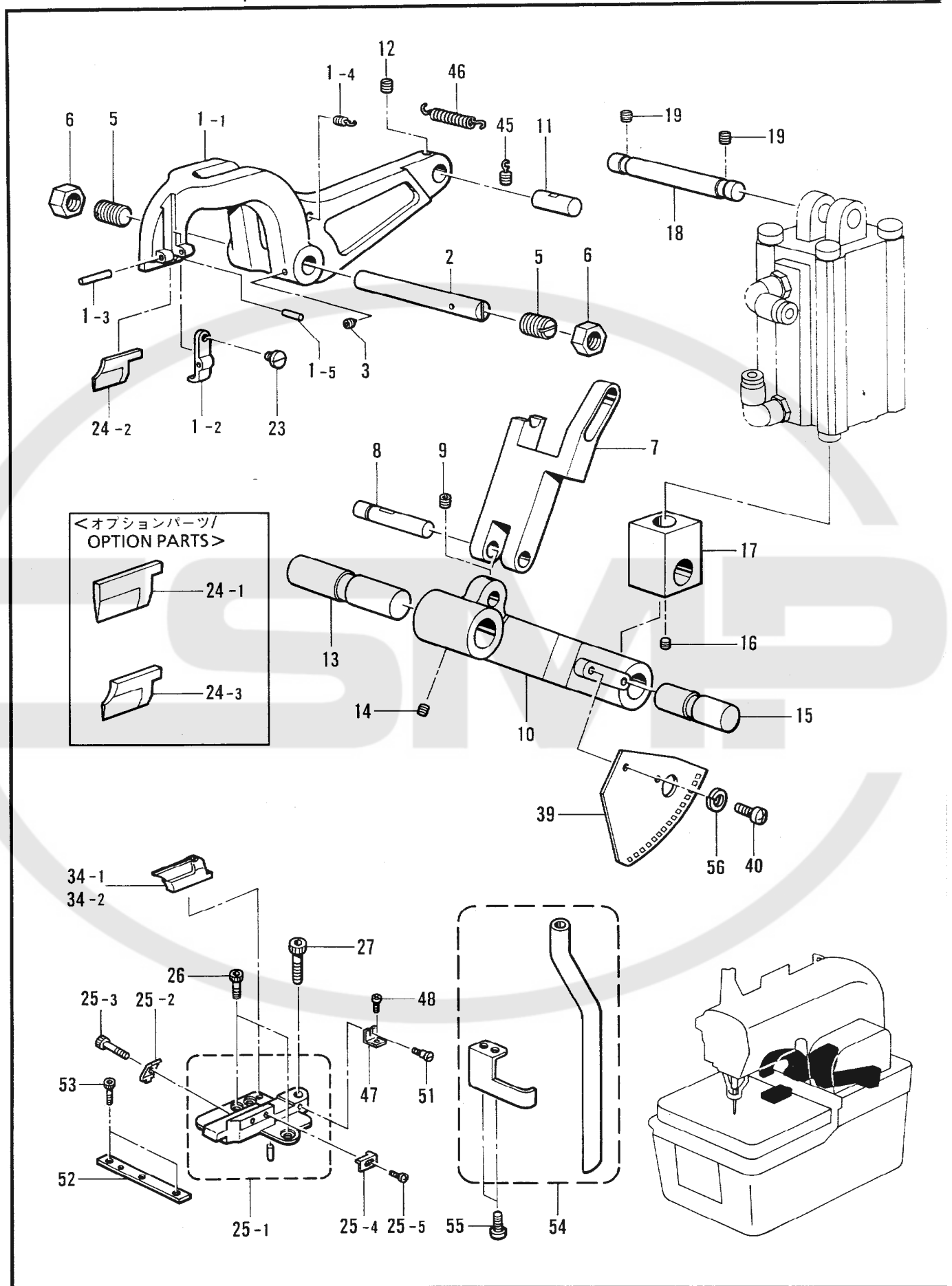

H. カッター関係 / Cutter mechanism / Abschneidevorrichtung /
 Mécanisme de la coupe / Mecanismo de la corta

REF.NO.	CODE	Q'TY	ヒンメイ	NAME OF PARTS	RM
1	S35074101	1	カッターウデクミ	CUTTER LEVER ASSY	
1-1	S35075101	1	カッターウデ	CUTTER LEVER	
1-2	S35076101	1	カッターカートリッジオサエ	CUTTER CARTRIDGE PRESSER	
1-3	S35077000	1	ニードルローラ4X25.8	NEEDLE ROLLER, M4X25.8	
1-4	S35078001	1	バネカケ	SPRING HOOK	
1-5	S35079000	1	ニードルローラ3X11.8	NEEDLE ROLLER, M3X11.8	
2	S35080001	1	カッターウデジク	CUTTER LEVER SHAFT	
3	016061031	1	アナトガリ 6X10	SET SCREW, SOCKET (CN) M6X10	
5	S35081001	2	カッターウデオサエネジ	CUTTER ARM SUPPORT SCREW	
6	S35082001	2	3シユナツト14	NUT, 3 M14	
7	S35088001	1	リンクA	LINK (A)	
8	S35085001	1	リンクジクC	LINK SHAFT (C)	
9	014060632	1	アナトメ6X6クボミ	SET SCREW, SOCKET (CP) M6X6	
10	S35087001	1	リンクC	LINK (C)	
11	S35086001	1	リンクジクB	LINK SHAFT (B)	
12	014060632	1	アナトメ6X6クボミ	SET SCREW, SOCKET (CP) M6X6	
13	S35083001	1	リンクジクA	LINK SHAFT (A)	
14	014060632	1	アナトメ6X6クボミ	SET SCREW, SOCKET (CP) M6X6	
15	S35084001	1	シリンダロツドジク	CYLINDER ROD SHAFT	
16	014060632	1	アナトメ6X6クボミ	SET SCREW, SOCKET (CP) M6X6	
17	S35089001	1	シリンダロツド	CYLINDER ROD	
18	S35090001	1	シリンダササエジク	CYLINDER SUPPORT SHAFT	
19	014060632	2	アナトメ6X6クボミ	SET SCREW, SOCKET (CP) M6X6	
23	S35091001	1	ツマミネジM5	KNOB SCREW, M5	
24-2	S35093001	1	ハンマー38 <38mm>	HAMMER (38) <38mm>	
25	S35473101	1	メスダイソウクミ	KNIFE BRACKET SET	
25-1	S35094101	1	メスダイクミ	KNIFE BRACKET ASSY	
25-2	S35097001	1	メスブロックオサエ	KNIFE BLOCK PRESSER	
25-3	018501622	1	アナボルト5X16	BOLT, SOCKET M5X16	
25-4	S35098000	1	ブロックストツパイタ	BLOCK STOPPER PLATE	
25-5	062300416	1	ナベコM3X4	SCREW, PAN M3X4	
26	018501222	2	アナボルト5X12	BOLT, SOCKET M5X12	
27	018062522	1	アナボルト6X25	BOLT, SOCKET M6X25	
34-1	S35436101	1	メス2.8X4.3-50	KNIFE, M2.8X4.3-50	※
34-2	S35437101	1	メス2.8X4.3-38	KNIFE, M2.8X4.3-38	※
39	S35099001	1	カッターセンサーシキリイタ	CUTTER SENSOR PARTITION PLATE	
40	062400812	2	ナベコ4X8	SCREW, PAN M4X8	
45	S35078001	1	バネカケ	SPRING HOOK	
46	142642001	1	サドウチヨウセツキヒキバネ	SPRING, EXTENSION	
47	S35100001	1	メスチヨウセツササエ	KNIFE ADJUST SUPPORT	
48	062400812	1	ナベコ4X8	SCREW, PAN M4X8	
51	S35101001	1	メスチヨウセツネジ	KNIFE ADJUST SCREW	
52	S35102001	1	メスダイアンナイ	KNIFE BRACKET GUIDE	
53	018400832	3	アナボルト4X8	BOLT, SOCKET M4X8	
54	S35104001	1	メスパイプクミ	KNIFE PIPE ASSY	
55	062400812	2	ナベコ4X8	SCREW, PAN M4X8	
56	028040242	2	バネザガネ2-4	WASHER, SPRING 2-4	
<オプションパーツ/OPTION PARTS>					
24-1	S35092001	1	ハンマー20 <20mm>	HAMMER (20) <20mm>	※
24-3	S35479001	1	ハンマー50 <50mm>	HAMMER (50) <50mm>	※

J. テンションプーリ関係 / Tension pulley mechanism / Spannrolle /
 Mécanisme de la poulie de tension / Mecanismo de la polea de tensión

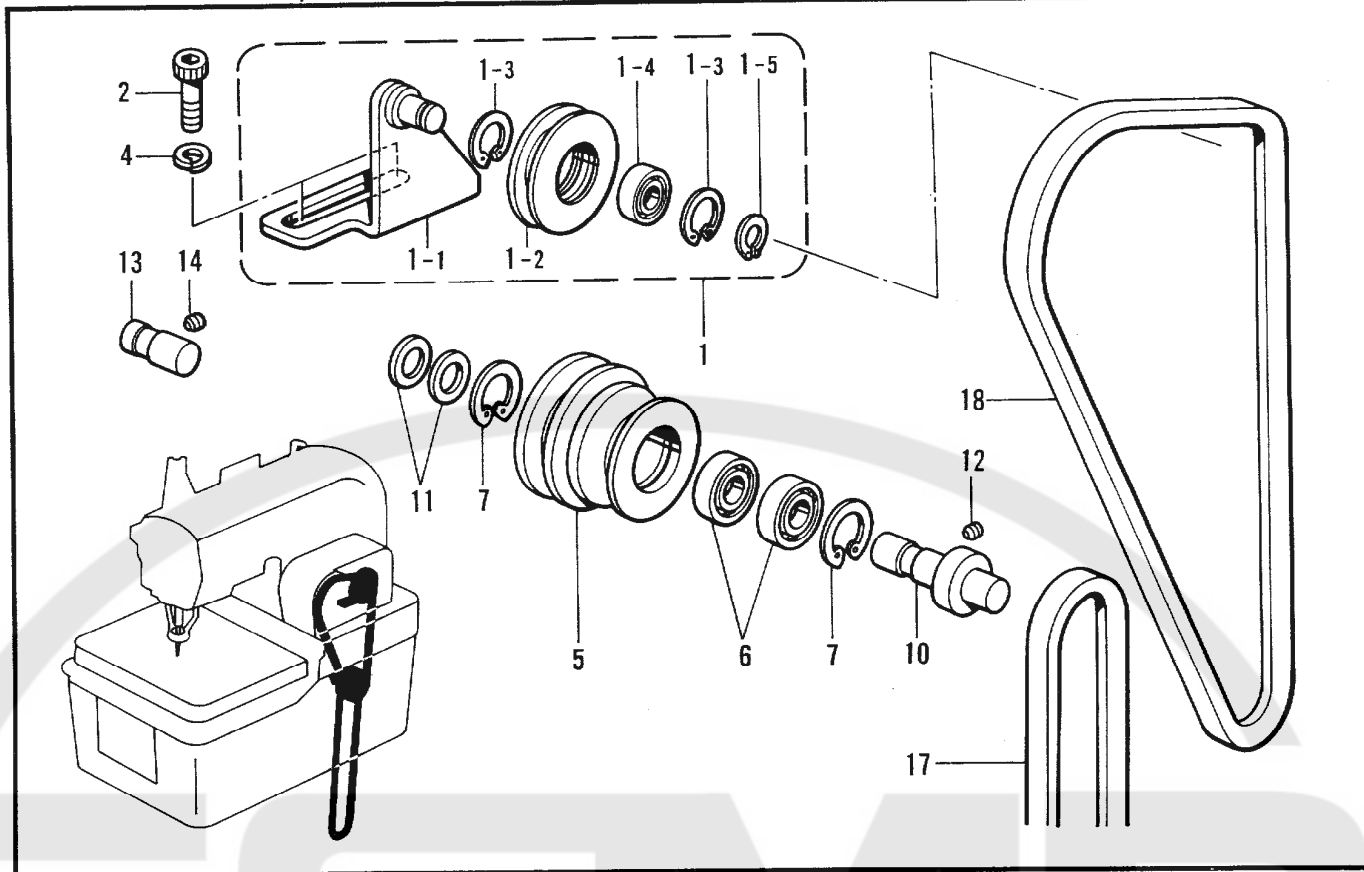

118-980-126

K. 下軸関係 / Lower shaft mechanism / Untere Welle /
 Mécanisme de l'arbre inférieur / Mecanismo del eje inferior

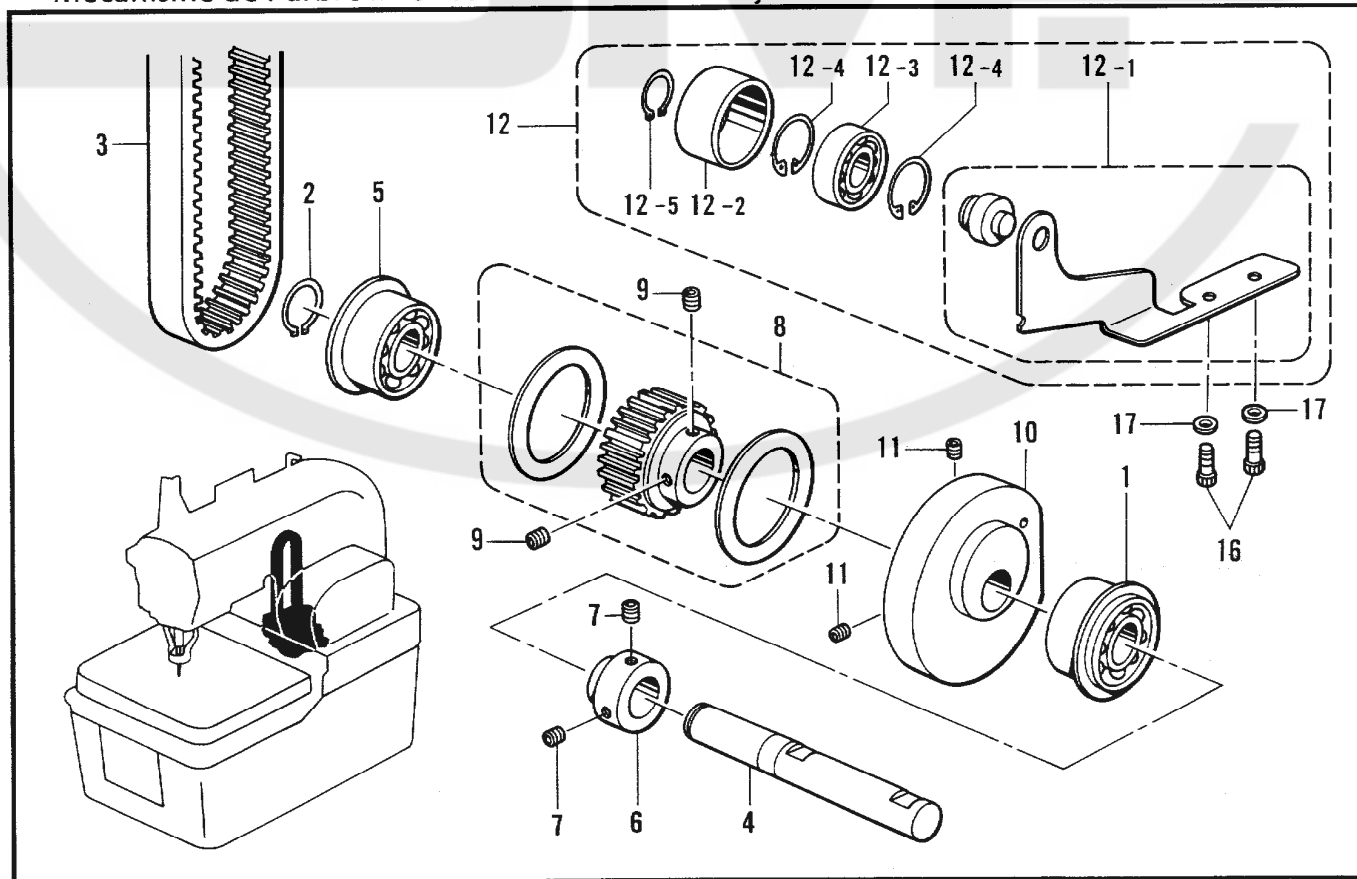

118-980-305

J. テンションプーリ関係 / Tension pulley mechanism / Spannrolle /
 Mécanisme de la poulie de tension / Mecanismo de la polea de tensión

REF.NO.	CODE	Q'TY	ヒンメイ	NAME OF PARTS	RM
1.	S35112001	1	Tプーリクミ	TENSION PULLEY ASSY	
1-1	S35431001	1	Tプーリササエイタクミ	TENSION PULLEY SUPPORT PLATE ASSY	
1-2	S35110001	1	テンションプーリ	TENSION PULLEY	
1-3	048280242	2	トメワアナヨウC28	RETAINING RING, C28	
1-4	076001800	1	タマジクウケ6001ZZ	BALL BEARING, 6001ZZ	
1-5	048120142	1	トメワジクヨウC12	RETAINING RING, C12	
2	018081636	2	アナボルト8X16	BOLT, SOCKET M8X16	
4	028080242	2	バネザガネ2-8	WASHER, SPRING 2-8	
5	S35108001	1	アイドラプーリ	IDLER PULLEY	
6	076002800	2	タマジクウケ6002ZZ	BALL BEARING, 6002ZZ	
7	048320242	2	トメワアナヨウC32	RETAINING RING, C32	
10	S35107001	1	アイドラプーリジク	IDLER PULLEY SHAFT	
11	116920001	2	オクリジクスラストリング	THRUST RING	
12	014060632	1	アナトメ6X6クボミ	SET SCREW, SOCKET (CP) M6X6	
13	S35106001	1	ベッドササエジク	BED SUPPORT SHAFT	
14	014060632	1	アナトメ6X6クボミ	SET SCREW, SOCKET (CP) M6X6	
17	S18707129	1	VベルトMシロ (M29)	BELT, VM WHITE (M29)	
18	S18707137	1	VベルトMシロ (M36)	BELT, VM WHITE (M36)	

118-980-126

K. 下軸関係 / Lower shaft mechanism / Untere Welle /
 Mécanisme de l'arbre inférieur / Mecanismo del eje inferior

REF.NO.	CODE	Q'TY	ヒンメイ	NAME OF PARTS	RM
1	076003850	1	タマジクウケ6003ZZ	BALL BEARING, 6003ZZ	
2	048150142	1	トメワジクヨウC15	RETAINING RING, C15	
3	S35275000	1	タイミングベルト665	TIMING BELT, 665	
4	S35273001	1	シタジクカムジク	CAM SHAFT	
5	076202850	1	タマジクウケ6202ZZ	BALL BEARING, 6202ZZ	
6	S35274001	1	セツトカラー	SET COLLAR	
7	S23651001	2	アナヒラ6X6ホソメ	SET SCREW, SOCKET (FT) M6X6	
8	S35272001	1	シタジクTプーリクミ	LOWER SHAFT TENSION PULLEY ASSY	
9	S23651001	2	アナヒラ6X6ホソメ	SET SCREW, SOCKET (FT) M6X6	
10	S35270001	1	シタジクカム	LOWER SHAFT CAM	
11	S23651001	2	アナヒラ6X6ホソメ	SET SCREW, SOCKET (FT) M6X6	
12	S35269001	1	テンションプーリクミ	TENSION PULLEY ASSY	
12-1	S35268001	1	テンションプーリウデクミ	ENSION PULLEY ARM ASSY	
12-2	S35265001	1	テンションプーリ	TENSION PULLEY	
12-3	076001800	1	タマジクウケ6001ZZ	BALL BEARING, 6001ZZ	
12-4	048280242	2	トメワアナヨウC28	RETAINING RING, C28	
12-5	048120142	1	トメワジクヨウC12	RETAINING RING, C12	
16	018502036	2	アナボルト5X20	BOLT, SOCKET M5X20	
17	025050232	2	ヒラザガネチュウ-5	WASHER, PLAIN M 5	

118-980-305

L1. 二重環ルーパ関係 / Double chain stitch looper mechanism / Doppelkettenstichgreifer / Mécanisme du boucleur pour point de chaînette double / Mecanismo del presilladora de doble cadeneta

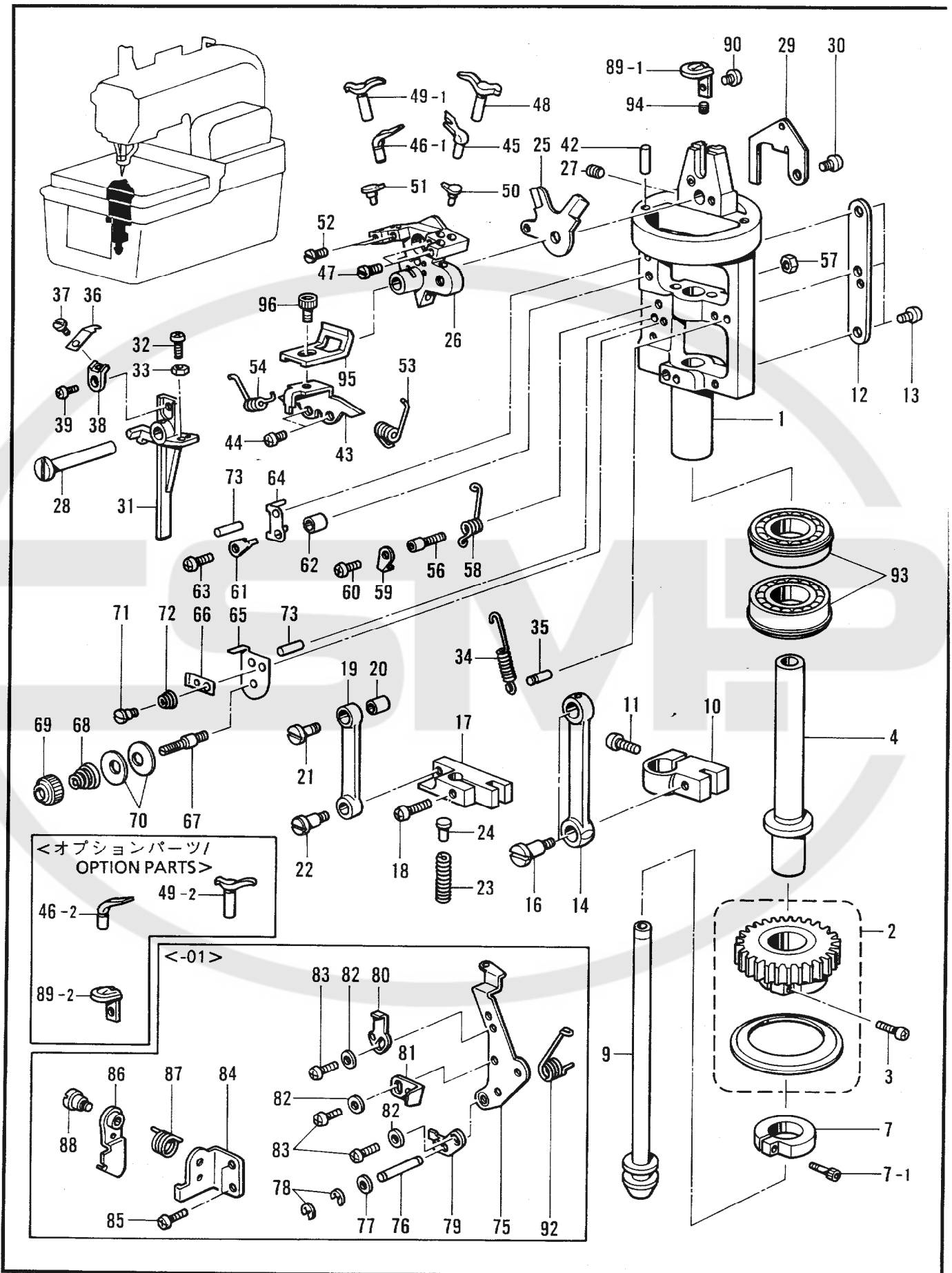

L1. 二重環ルーパ関係 / Double chain stitch looper mechanism / Doppelkettenstichgreifer /
 Mécanisme du boucleur pour point de chaînette double /
 Mecanismo del presilladora de double cadeneta

REF.NO.	CODE	Q'TY	ヒンメイ	NAME OF PARTS	RM
1	S34948001	1	レースドダイ	LOOPER BASE	
2	S35007000	1	レースプーリクミ	LOOPER PULLEY ASSY	
3	062351615	1	ナベコ35X16	SCREW, PAN M35X16	
4	S35010001	1	ルーパークドウジク	LOOPER DRIVING SHAFT	
7	S37432001	1	ハリボウブロツクダキクミ	NEEDLE BAR BLOCK CLAMP ASSY	
7-1	018301632	1	アナボルト3X16	BOLT, SOCKET M3X16	
9	S35053001	1	スプレダーリンクジク	SPREADER LINK SHAFT	
10	S35011001	1	ルーパリンクシテン	LOOPER LINK CLAMP	
11	062501202	1	ナベコM5X12	SCREW, PAN M5X12	
12	S35012001	1	LSスライドアンナイ	LS-SLIDE GUIDE	
13	062300612	3	ナベコ3X6	SCREW, PAN M3X6	
14	S35015001	1	ルーパリンク	LOOPER LINK	
16	S35013001	2	ダンネジM4	STUD SCREW, M4	
17	S35016001	1	スプレダーリンクダイ	SPREADER LINK BASE	
18	062501202	1	ナベコM5X12	SCREW, PAN M5X12	
19	S35017001	1	スプレダーカムリンク	SPREADER CAM LINK	
20	S35018001	1	カムリンクカラー	CAM LINK COLLAR	
21	S35014001	1	ダンネジM4	STUD SCREW, M4	
22	S35019001	1	ダンネジM4	STUD SCREW, M4	
23	S35020001	2	スプレダーバネ	SPREADER SPRING	
24	S35021000	2	スプレダーバネアンナイ	SPREADER SPRING GUIDE	
25	S35022001	1	スプレダーサドウカム	SPREADER DIFFERENTIAL CAM	
26	S35023001	1	LSホルダーダイ	LS-HOLDER BRACKET	
27	014060832	1	アナトメネジ6X8クボミ	SET SCREW, SOCKET (CP) M6X8	
28	S35024101	1	ホルダーササエジク	HOLDER SUPPORT SHAFT	
29	S35054001	1	シンイトアンナイC	GIMP GUIDE (C)	
30	060400516	1	バインドM4X5	SCREW, BIND M4X5	
31	S35025001	1	イトキリレバードダイ	THREAD TRIMMER LEVER BRACKET	
32	062301016	1	ナベコM3X10	SCREW, PAN M3X10	
33	021300302	1	3シユナツト3	NUT, 3 M3	
34	S35027001	1	Uイトキリバネ	U-THREAD TRIMMER SPRING	
35	S35028000	1	ダウエルピン3X16	DOWEL PIN, M3X16	
36	S35029001	1	ウワイドウハA	UPPER MOVABLE KNIFE (A)	
37	105288001	1	シメネジ2.38	SCREW, M2.38	
38	S35026001	1	ウワイドウハダイ	UPPER MOVABLE KNIFE BRACKET	
39	060300416	1	バインド3X4	SCREW, BIND M3X4	
42	S35030001	1	イトアンナイパイプ	THREAD GUIDE PIPE	
43	S36660001	1	ハリウケササエ	NEEDLE GUARD SUPPORT	
44	062300612	2	ナベコ3X6	SCREW, PAN M3X6	
45	S35410001	1	ルーパR	LOOPER (R)	
46-1	S35411001	1	アイルーパ	EYE LOOPER	
47	S35032101	2	シメネジ2.6X5.5	SCREW, M2.6X5.5	
48	S35412001	1	スプレダーR	SPREADER (R)	
49-1	S35413001	1	スプレダーL	SPREADER (L)	
50	S35034001	1	スプレダーストツパR	SPREADER STOPPER (R)	
51	S35033001	1	スプレダーストツパL	SPREADER STOPPER (L)	
52	S35032101	2	シメネジ2.6X5.5	SCREW, M2.6X5.5	
53	S35035001	1	スプレダーバネR	SPREADER SPRING (R)	
54	S35036001	1	スプレダーバネL	SPREADER SPRING (L)	
56	S35037001	1	バネアンナイジク	SPRING GUIDE SHAFT	
57	021400202	1	2シユナツト4	NUT, 2 M4	
58	S35038001	1	イトトリバネ	THREAD TAKE-UP SPRING	
59	S35039000	1	Lイトトリバネササエ	L-THREAD TAKE-UP SPRING SUPPORT	
60	060300416	1	バインド3X4	SCREW, BIND M3X4	
61	S35040000	1	Lイトトリバネアンナイ	L-THREAD TAKE-UP SPRING GUIDE	
62	S35018001	1	カムリンクカラー	CAM LINK COLLAR	
63	062401416	1	ナベコ4X14	SCREW, PAN M4X14	
64	S35041000	1	イトササエイタ	THREAD SUPPORT PLATE	
65	S35043001	1	Lイトオサエダイ	L-THREAD PRESSER BASE	

L1. 二重環ルーパ関係 / Double chain stitch looper mechanism / Doppelkettenstichgreifer /
 Mécanisme du boucleur pour point de chaînette double /
 Mecanismo del presilladora de double cadeneta

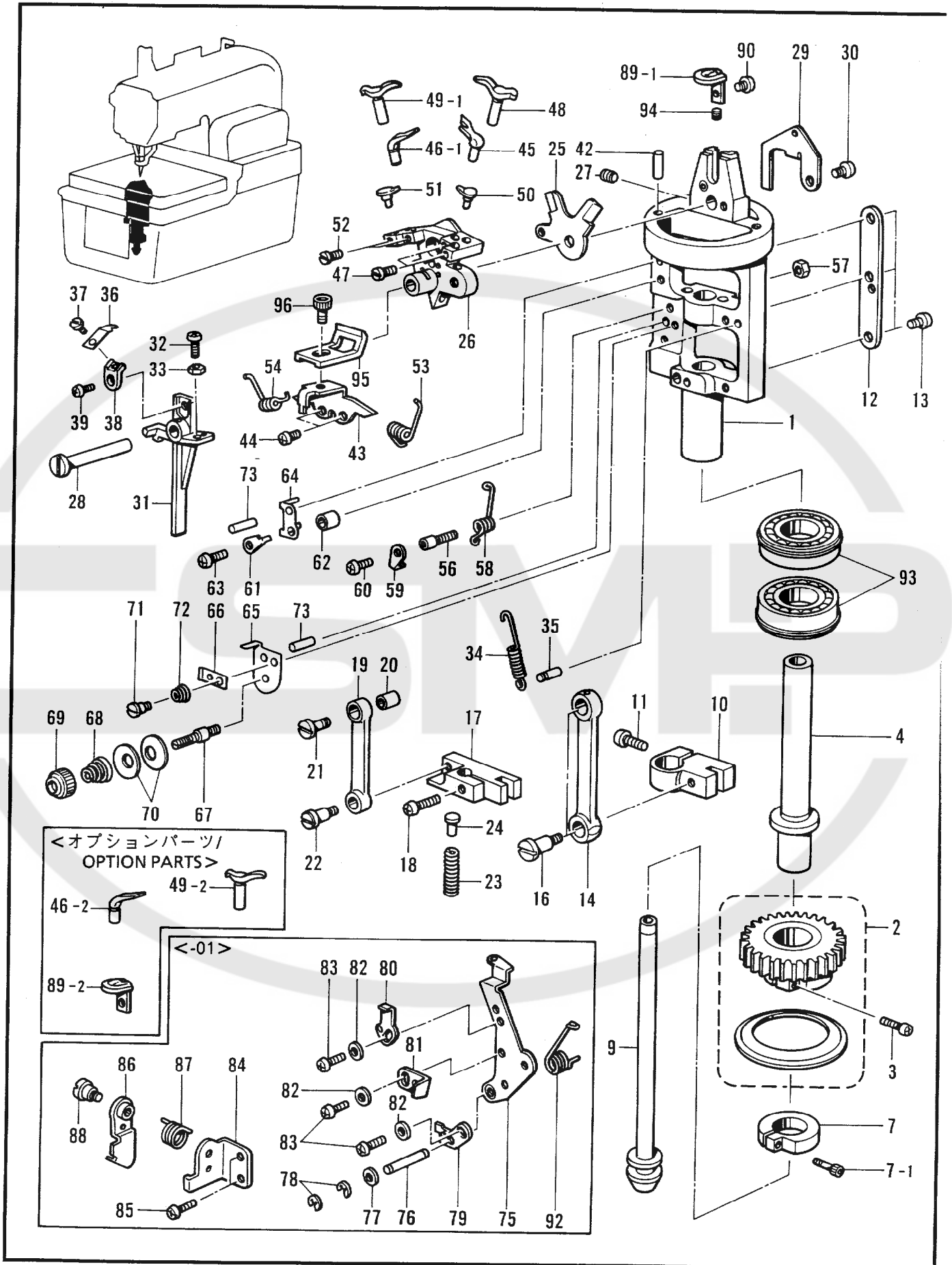

L1. 二重環ルーパ関係 / Double chain stitch looper mechanism / Doppelkettenstichgreifer /
 Mécanisme du boucleur pour point de chaînette double /
 Mecanismo del presilladora de double cadeneta

REF.NO.	CODE	Q'TY	ヒンメイ	NAME OF PARTS	RM
66	S35042000	1	ライトオサエ	L-THREAD PRESSER	
67	S35044001	1	ライトチヨウシボウ	L-TENSION STUD	
68	154562001	1	プレテンションバネB	PRE-TENSION SPRING (B)	
69	155510001	1	イトチヨウシナツト	TENSION NUT	
70	144504001	2	イトアンナイサラ	THREAD GUIDE DISC	
71	S35045001	1	ダンネジM3	STUD SCREW, M3	
72	S35118001	1	ハリイトチヨウシバネ	TENSION SPRING	
73	S35046000	2	ニードルピン3X17.8	NEEDLE PIN, M3X17.8	
89-1	S38887001	1	スロートプレート1.3	THROAT PLATE (1.3)	
90	S35326001	1	シメネジM3.5	SCREW, M3.5	
93	076003850	2	タマジクウケ6003ZZ	BALL BEARING, 6003ZZ	
94	014300832	1	アナクボミM3X8	SET SCREW, SOCKET (CP) M3X8	
95	S36659001	1	ハリウケU	NEEDLE GUARD (U)	
96	018300532	1	アナボルト3X5	BOLT, SOCKET M3X5	
<-01> <上下糸切り用 / FOR UPPER AND LOWER THREAD TRIMMER>					
75	S35048101	1	イトユルメレバー	TENSION RELEASE LEVER	
76	S35049001	1	イトユルメレバージク	TENSION RELEASE LEVER SHAFT	
77	025680132	2	ヒラザガネシヨウ4.37	WASHER, PLAIN S 4.37	
78	048030342	2	トメワE3	RETAINING RING, E3	
79	S35050001	1	ルーハーイトユルメ	LOOPER TENSION RELEASE	
80	S35051001	1	イトユルメチヨウセツイタ	TENSION RELEASE PLATE	
81	S35365101	1	イトユルメレバーツメ	TENSION RELEASE LEVER CLAW	
82	025350236	3	ヒラザガネチユウ3.5	WASHER, PLAIN M 3.5	
83	062350516	3	ナベコ3.5X5	SCREW, PAN M3.5X5	
84	S35366001	1	イトユルメツメササエ	TENSION RELEASE CLAW SUPPORT	
85	062400812	2	ナベコ4X8	SCREW, PAN M4X8	
86	S35052001	1	イトユルメツメ	TENSION RELEASE CLAW	
87	S35055001	1	イトユルメツメバネ	TENSION RELEASE CLAW SPRING	
88	S35056001	1	ダンネジM4	STUD SCREW, M4	
92	S35057001	1	イトユルメレバーバネ	THREAD RELEASE LEVER SPRING	
<オプションパーツ / OPTION PARTS>					
<太糸用 / FOR HEAVY >					
46-2	S35471001	1	アイルーパB	EYE LOOPER (B)	
49-2	S35472001	1	スプレダーLB	SPREADER (LB)	
<かがり幅大 / FOR WIDE STITCH WIDTH >					
89-2	S35392001	1	スロートプレート1.8	THROAT PLATE (1.8)	
89-2	S35391001	1	スロートプレート2.5	THROAT PLATE (2.5)	
<かがり幅中小 / FOR NARROW STITCH WIDTH >					
89-2	S38888001	1	スロートプレート0.8	THROAT PLATE (0.8)	

M. ルーパー関係 / Looper mechanism / Greifer /
 Mécanisme des griffes / Mecanismo del presilladora

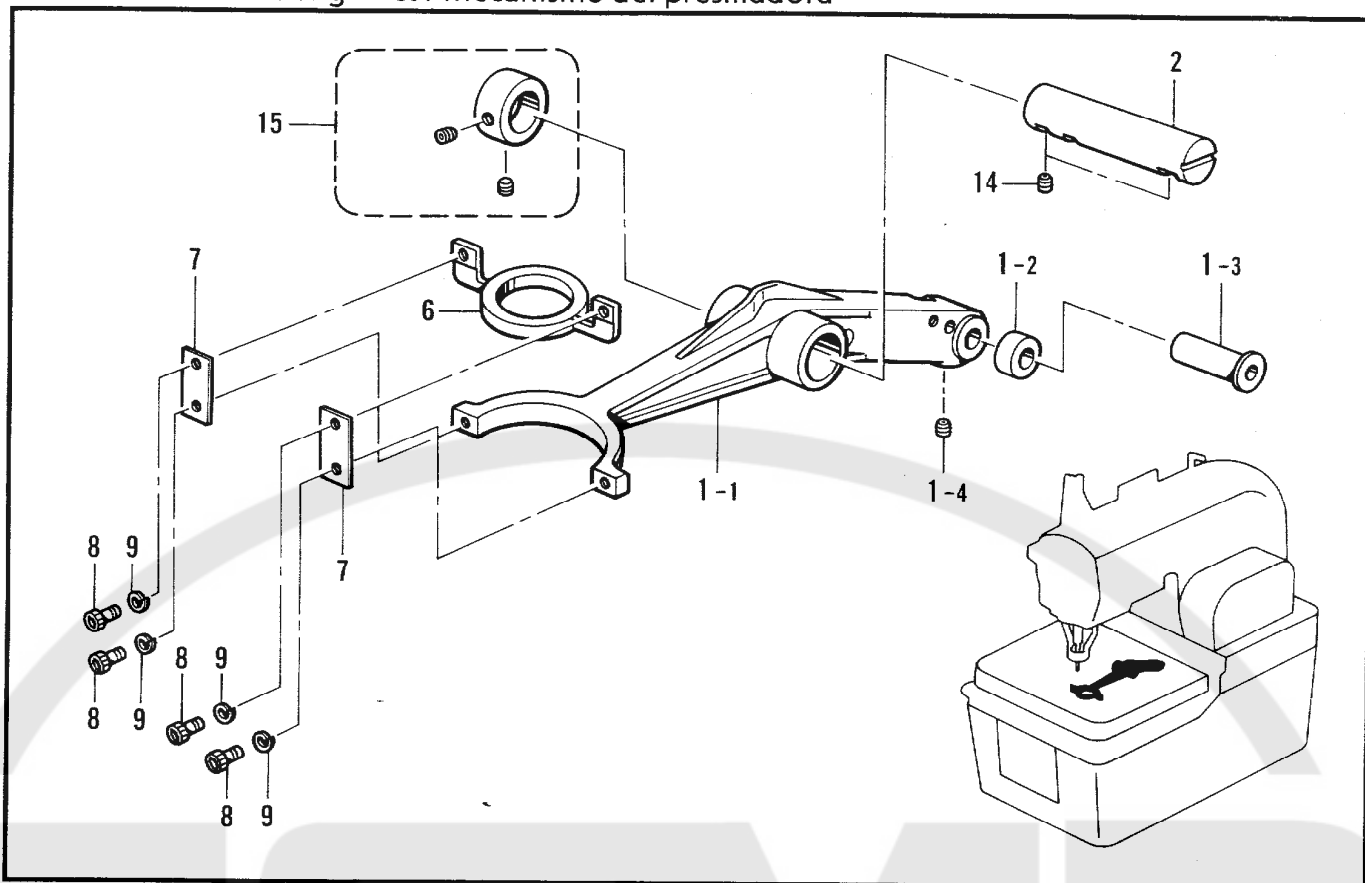

118-980-306

N. スプレダー関係 / Spreader mechanism / Spreizvorrichtung /
 Mécanisme de l'étendeur / Mecanismo extensor

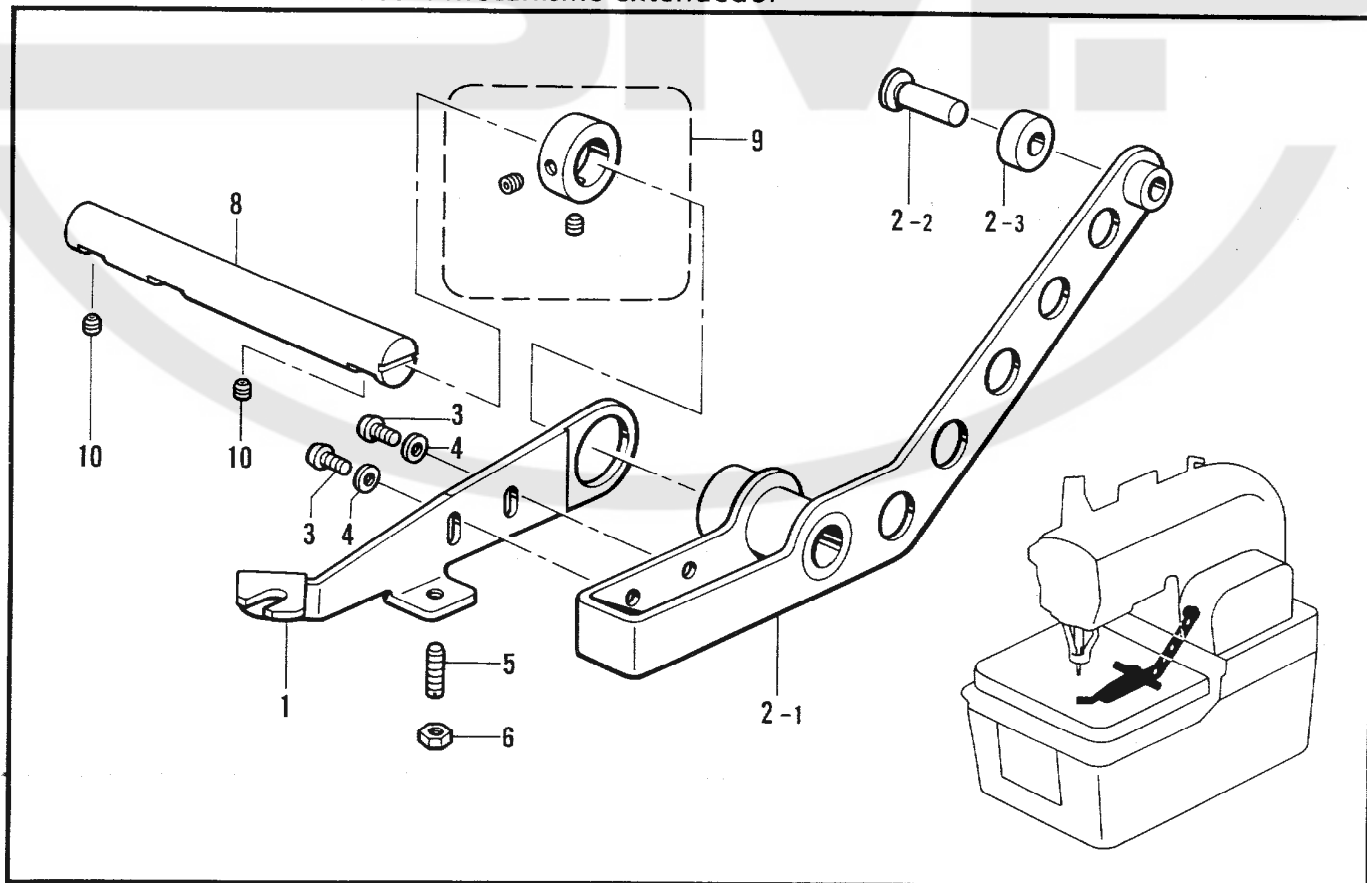

118-980-310

M. ルーパー関係 / Looper mechanism / Greifer /
 Mécanisme des griffes / Mecanismo del presilladora

REF.NO.	CODE	Q'TY	ヒンメイ	NAME OF PARTS	RM
1	S35066001	1	ルーパーリンククミ	LOOPER LINK ASSY	
1-1	S35067001	1	ルーパーリンク	LOOPER LINK	
1-2	S35063001	1	ルーパーカムコロ	LOOPER CAM ROLLER	
1-3	S35064001	1	ルーパーカムコロピン	LOOPER CAM ROLLER PIN	
1-4	014060632	1	アナトメ6X6クボミ	SET SCREW, SOCKET (CP) M6X6	
2	S35065001	1	ルーパーリンクササエジク	LOOPER LINK SUPPORT SHAFT	
6	S35062001	1	ルーパーサドウタイ	LOOPER DRIVING PLATE	
7	S35061000	2	ルーパーリンクバネ	LOOPER LINK SPRING	
8	S10439001	4	アナボルト3	BOLT, SOCKET M3	
9	028030242	4	バネザガネ2-3	WASHER, SPRING 2-3	
14	014060632	2	アナトメ6X6クボミ	SET SCREW, SOCKET (CP) M6X6	
15	S23612001	1	セツトカラークミ	SET COLLAR ASSY	

118-980-306

N. スプレダー関係 / Spreader mechanism / Spreizvorrichtung /
 Mécanisme de l'étendeur / Mecanismo extendedor

REF.NO.	CODE	Q'TY	ヒンメイ	NAME OF PARTS	RM
1	S35073001	1	スプレダクドウレバー	SPREADER DRIVING LEVER	
2	S35072101	1	スプレダーレバークミ	SPREADER LEVER ASSY	
2-1	S35071001	1	スプレダーカムレバー	SPREADER CAM LEVER	
2-2	S35070101	1	スプレダーカムコロピン	SPREADER CAM ROLLER PIN	
2-3	S35069001	1	スプレダーカムコロ	SPREADER CAM ROLLER	
3	062400812	2	ナベコ4X8	SCREW, PAN M4X8	
4	025040232	2	ヒラザガネチユウ4	WASHER, PLAIN M 4	
5	S35068001	1	トメネジM3.5	SET SCREW, M3.5	
6	021350106	1	1シユナツト35	NUT, 1 M3.5	
8	S35065001	1	ルーパーリンクササエジク	LOOPER LINK SUPPORT SHAFT	
9	S23612001	1	セツトカラークミ	SET COLLAR ASSY	
10	014060632	2	アナトメ6X6クボミ	SET SCREW, SOCKET (CP) M6X6	

118-980-310

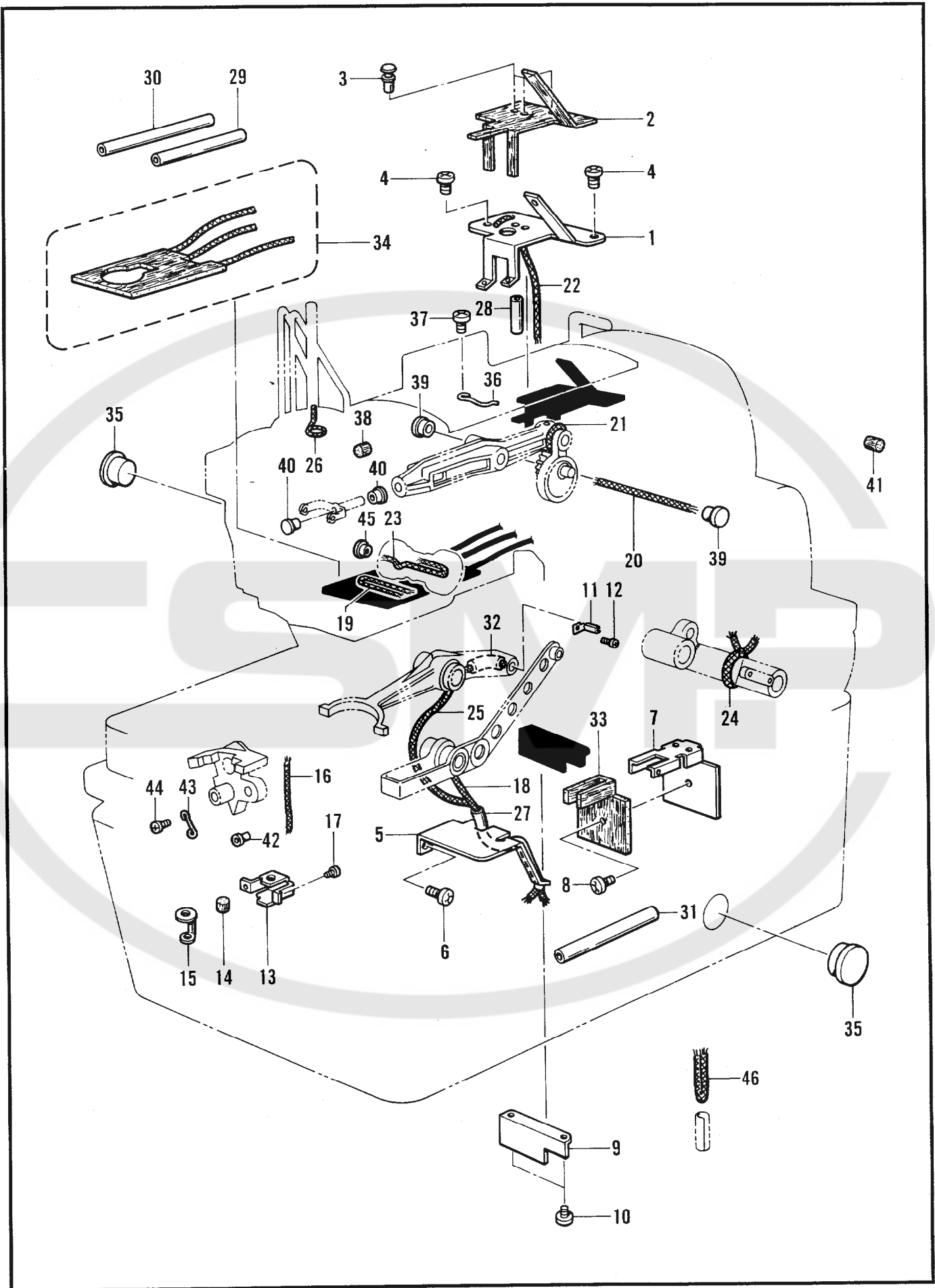

P. 給油潤滑関係 / Lubrication / Schmierung / Lubrification / Lubricación

REF.NO.	CODE	Q'TY	ヒンメイ	NAME OF PARTS	RM
1	S35003001	1	トウシンササエL	WICK SUPPORT (L)	
2	S35002000	1	トウシンササエLフェルト	WICK SUPPORT (L) FELT	
3	S35001000	4	ナイロンリベット	NYLON RIVET	
4	062350616	2	ナベコM3.5X6	SCREW, PAN M3.5X6	
5	S35000001	1	ルーバオイルササエ	LOOPER OIL SUPOORT	
6	062400616	1	ナベコM4X6	SCREW, PAN M4X6	
7	S34999001	1	トウシンササエD	WICK SUPOORT (D)	
8	062400616	1	ナベコM4X6	SCREW, PAN M4X6	
9	S34998001	1	シタジクカムカバー	LOWER SHAFT CAM COVER	
10	062400616	2	ナベコM4X6	SCREW, PAN M4X6	
11	S34997001	1	ルーバトウシンオサエ	LOOPER WICK SUPPORT	
12	062300416	1	ナベコM3X4	SCREW, PAN M3X4	
13	S34996001	1	レースフェルトオサエ	FELT SUPPORT	
14	113006001	1	フェルト	FELT	
15	S34995000	1	レースフェルトA	FELT (A)	
16	S35414000	2	リリアンクミヒモ	WICK	
17	062300416	1	ナベコM3X4	SCREW, PAN M3X4	
18	S34994000	1	クミヒモ4X4 (L=130)	WICK 4X4 (L=130)	
19	S36683000	1	クミヒモ4X4 (L=100)	WICK 4X4 (L=100)	
20	S34993000	1	クミヒモ4X4 (L=70)	WICK 4X4 (L=70)	
21	S34992000	1	クミヒモ4X4 (L=170)	WICK 4X4 (L=170)	
22	S34991000	1	クミヒモ4X4 (L=450)	WICK 4X4 (L=450)	
23	S34990000	1	クミヒモ6X6 (L=100)	WICK 6X6 (L=100)	
24	S34989000	1	クミヒモ4X4 (L=300)	WICK 4X4 (L=300)	
25	S34988000	1	クミヒモ4X4 (L=120)	WICK 4X4 (L=120)	
26	S34987000	1	クミヒモ6X6 (L=120)	WICK 6X6 (L=120)	
27	S34986000	1	ビニルチューブ (L=135)	OIL TUBE (L=135)	
28	S34985000	1	ビニルチューブ (L=90)	OIL TUBE (L=90)	
29	S34984000	1	ビニルチューブ (L=150)	OIL TUBE (L=150)	
30	S34983000	1	ビニルチューブ (L=160)	OIL TUBE (L=160)	
31	S34982000	1	ビニルチューブ (L=70)	OIL TUBE (L=70)	
32	S34981000	1	ビニルチューブ (L=50)	OIL TUBE (L=50)	
33	S34980000	1	フェルト	FELT	
34	S34979000	1	フェルトクミ	FELT ASSY	
35	152948001	2	オイルボツトマド	OIL WINDOW	
36	117150001	2	コードササエカネ	WICK SUPPORT	
37	062350616	2	ナベコM3.5X6	SCREW, PAN M3.5X6	
38	S34974000	2	ロツドフェルト	ROD FELT	
39	143196001	2	オイルニガシグチ	OIL CAP	
40	143196001	2	オイルニガシグチ	OIL CAP	
41	S34973000	1	ロツドフェルト	ROD FELT	
42	S34972000	1	ビニルチューブ	OIL TUBE	
43	S34971001	1	クミヒモササエ	WICK SUPPORT	
44	062300416	1	ナベコM3X4	SCREW, PAN M3X4	
45	143196001	1	オイルニガシグチ	OIL CAP	
46	S37173000	1	クミヒモ3X3 (L=50)	WICK 3X3 (L=50)	

Q. 糸通シ関係 / Threading mechanism / Fadenführungsrichtung /
 Mécanisme de l'enfilage / Mecanismo del enhebrado

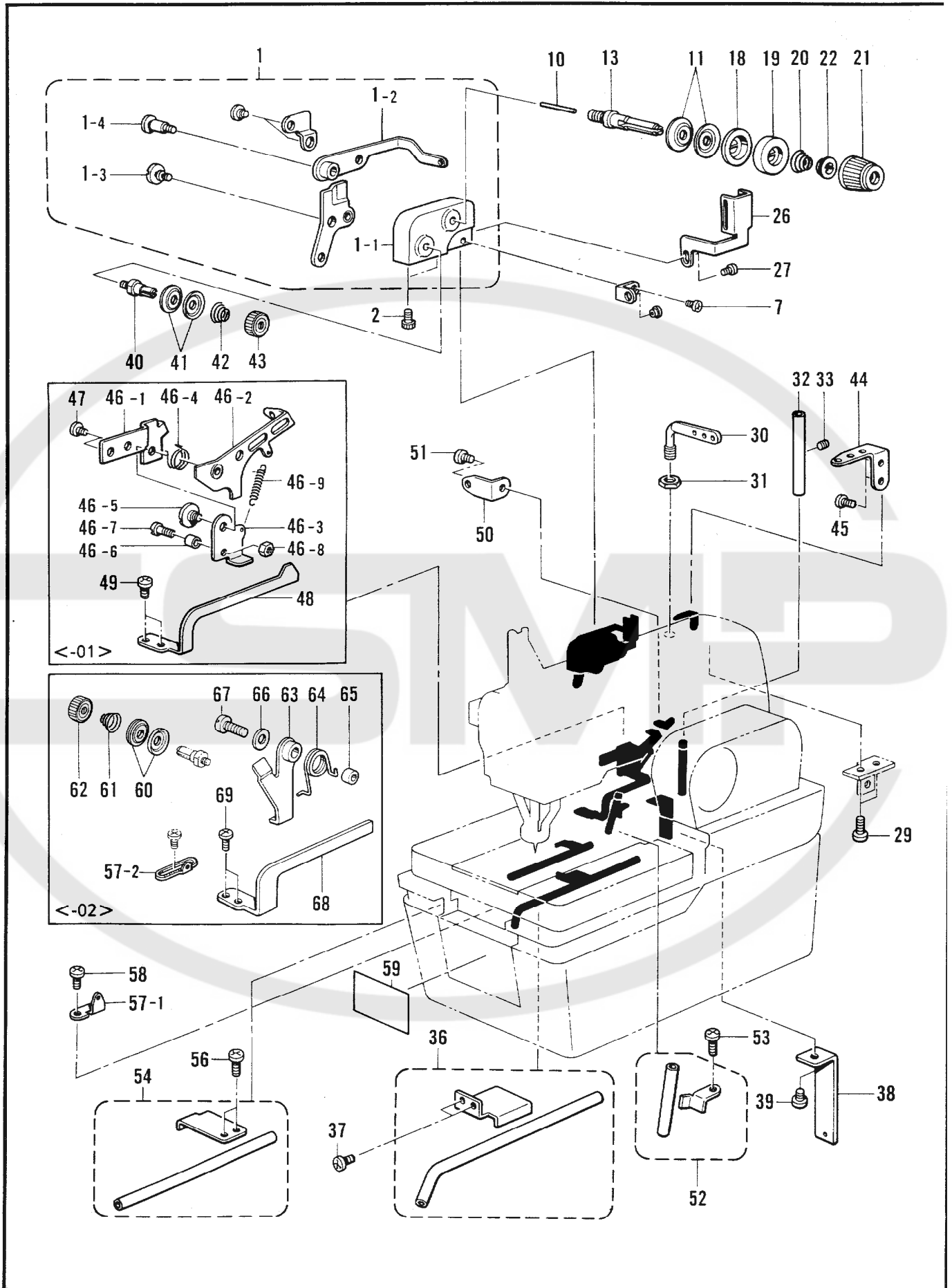

Q. 糸通シ関係 / Threading mechanism / FadenführungsVorrichtung /
Mécanisme de l'enfilage / Mecanismo del enhebrado

REF.NO.	CODE	Q'TY	ヒンメイ	NAME OF PARTS	RM
1	S37874101	1	ウワイトテンションダイクミ	UPPER THREAD TENSION BRACKET ASSY	
1-1	S34917001	1	ウワイトテンションダイ	UPPER THREAD TENSION BRACKET	
1-2	S34918101	1	ウワイトトリレバークミ	UPPER THREAD TAKE-UP LEVER ASSY	
1-3	S34966001	1	ダンネジM4	STUD SCREW, M4	
1-4	S34922101	1	ダンネジM4	STUD SCREW, M4	
2	018401236	2	アナボルト4X12	BOLT, SOCKET M4X12	
7	062350616	1	ナベコM3.5X6	SCREW, PAN M3.5X6	
10	159220101	1	イトユルメピン	PIN	
11	145446001	2	イトチヨウシサラ	TENSION DISC	
13	S34923001	1	ウワイトチヨウシボウ	UPPER THREAD TENSION STUD	
18	159805001	1	イトチヨウシサラオサエ	TENSION DISC PRESSER	
19	144103009	1	イトチヨウシサラオサエ	TENSION DISC PRESSER	
20	159221001	1	イトチヨウシバネ	TENSION SPRING	
21	S20682102	1	イトチヨウシナツト (ミドリ)	TENSION NUT (GREEN)	
22	S20681000	1	チヨウシバネウエザガネ	WASHER	
26	S34924001	1	ウワイトトリレバーアンナイ	UPPER THREAD TAKE-UP LEVER GUIDE	
27	062350616	1	ナベコM3.5X6	SCREW, PAN M3.5X6	
29	062400812	2	ナベコ4X8	SCREW, PAN M4X8	
30	S35466001	1	ミツメイトカケ	THREAD RETAINER	
31	021060306	1	3シュナツト6	NUT, 3 M6	
32	150644009	1	イトアンナイパイプS	THREAD GUIDE PIPE (S)	
33	012400636	1	アナヒラ4X6	SET SCREW, SOCKET (FT) M4X6	
36	S34926001	1	イトアンナイパイプDクミ	THREAD GUIDE PIPE (D) ASSY	
37	062400612	2	ナベコM4X6	SCREW, PAN M4X6	
38	S34928001	1	イトアンナイB	THREAD GUIDE (B)	
39	062400612	1	ナベコM4X6	SCREW, PAN M4X6	
40	S20698001	1	イトチヨウシボウ	TENSION STUD	
41	144504001	2	イトアンナイサラ	THREAD GUIDE DISC	
42	154562001	1	プレテンションバネB	PRE-TENSION SPRING (B)	
43	155510001	1	イトチヨウシナツト	TENSION NUT	
44	152889001	1	ミツメイトカケ	THREAD RETAINER	
45	062350616	2	ナベコM3.5X6	SCREW, PAN M3.5X6	
50	S34942001	1	シンイトアンナイ	GIMP THREAD GUIDE	
51	062400812	1	ナベコ4X8	SCREW, PAN M4X8	
52	S34934001	1	シンイトアンナイSクミ	GIMP THREAD GUIDE (S) ASSY	
53	062400812	1	ナベコ4X8	SCREW, PAN M4X8	
54	S34932001	1	シンイトアンナイパイプクミ	GIMP THREAD GUIDE PIPE ASSY	
56	062400812	2	ナベコ4X8	SCREW, PAN M4X8	
57-1	S35430001	1	シンイトアンナイB	GIMP THREAD GUIDE (B)	
58	062400812	1	ナベコ4X8	SCREW, PAN M4X8	
59	S35912001	1	イトトオシセツメイバン	THREADING DIAGRAM PLATE	
<-01><上下糸切り用/FOR UPPER AND LOWER THREAD TRIMMER>					
46	S34944001	1	シンイトトリレバークミ	GIMP THREAD TAKE-UP LEVER ASSY	
46-1	S34936001	1	シンイトトリササエイタ	GIMP THREAD TAKE-UP SUPPORT PLATE	
46-2	S34937001	1	シンイトトリレバー	GIMP THREAD TAKE-UP LEVER	
46-3	S34938001	1	シンイトトリサドウイタ	GIMP THREAD TAKE-UP DRIVING PLATE	
46-4	S34940001	1	シンイトトリバネ	GIMP THREAD TAKE-UP SPRING	
46-5	S34941001	1	ダンネジM4	STUD SCREW, M4	
46-6	S35018001	1	カムリンクカラー	CAM LINK COLLAR	
46-7	S34943001	1	ダンネジM4	STUD SCREW, M4	
46-8	021400106	1	ナツト1シュ4	NUT, 1 M4	
46-9	S35428001	1	サドウイタモドシバネ	SPRING	
47	062400812	2	ナベコ4X8	SCREW, PAN M4X8	
48	S34939001	1	シンイトトリアンナイ	GIMP THREAD TAKE-UP GUIDE	
49	062400812	2	ナベコ4X8	SCREW, PAN M4X8	
<-02><ジーンズ仕様/FOR JEANS SPECIFICATION>					
57-2	S37697001	1	シンイトアンナイJ	GIMP THREAD GUIDE (J)	
60	144504001	2	イトアンナイサラ	THREAD GUIDE DISC	
61	154562001	1	プレテンションバネB	PRE-TENSION SPRING (B)	
62	155510001	1	イトチヨウシナツト	TENSION NUT	
63	S37745001	1	シンイトユルメイタ	GIMP THREAD RELEASE PLATE	
64	S37749001	1	シンイトユルメイタバネ	GIMP THREAD RELEASE PLATE SPRING	
65	147236001	1	メストリツケウデコロ	KNIFE SET ARM ROLLER	
66	025040232	1	ヒラザガネチユウ4	WASHER, PLAIN M 4	
67	062401212	1	ナベコ4X12	SCREW, PAN M4X12	
68	S37750001	1	シンイトトリアンナイJ	GIMP THREAD TAKE-UP GUIDE (J)	
69	062400812	2	ナベコ4X8	SCREW, PAN M4X8	

R1. 糸切り関係 / Thread trimmer mechanism / Fadenabschneidevorrichtung /
 Mécanisme de coupe-fil / Mecanismo de la cortadura de hiros

<-01> <上下糸切り用 / FOR UPPER AND LOWER THREAD TRIMMER>

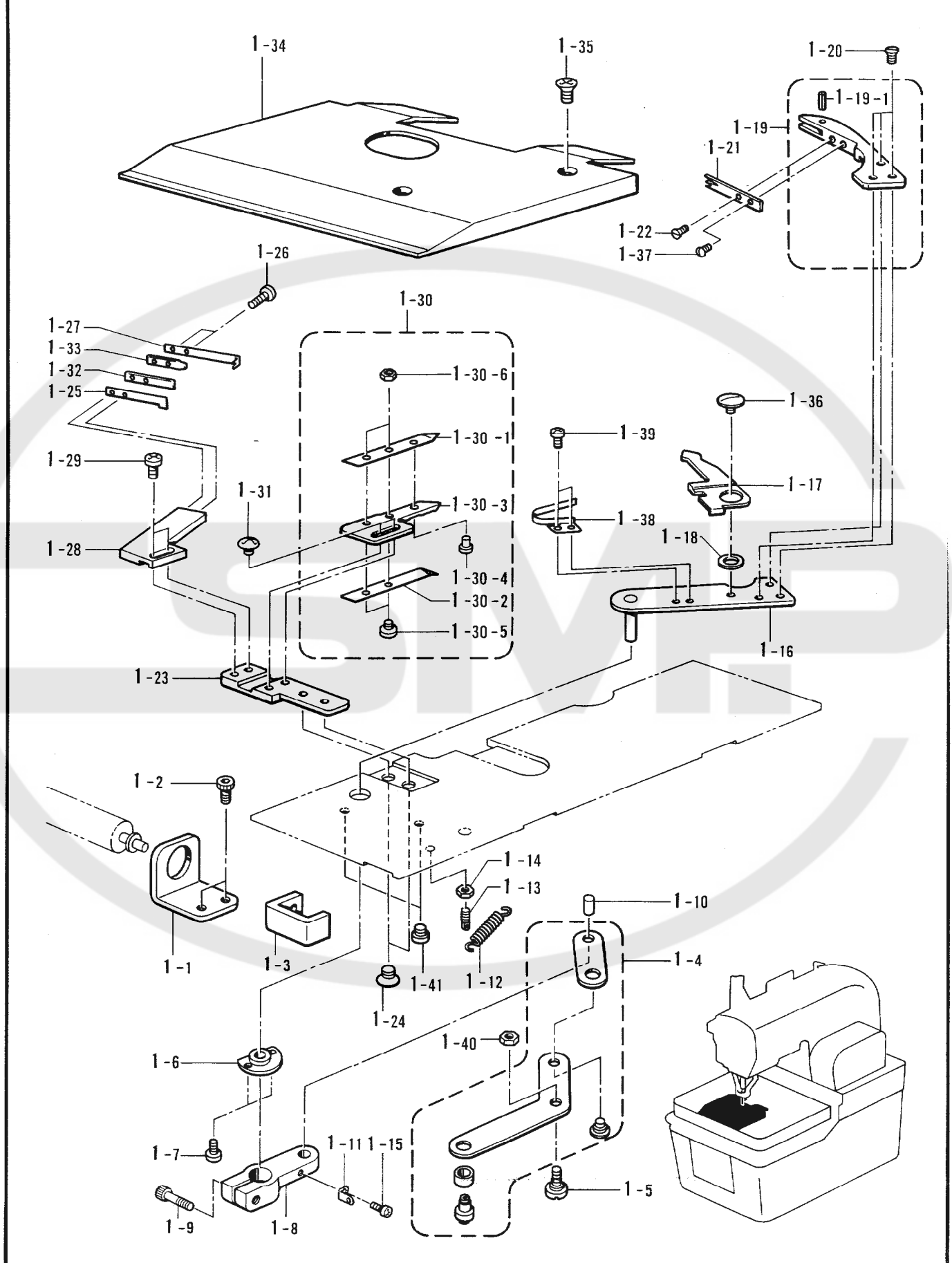

118-980-403

R1. 糸切り関係 / Thread trimmer mechanism / Fadenabschneidevorrichtung /
Mécanisme de coupe-fil / Mecanismo de la cortadura de hiros

REF.NO.	CODE	Q'TY	ヒンメイ	NAME OF PARTS	RM
<-01><上下糸切り用/ FOR UPPER AND LOWER THREAD TRIMMER>					
1-1	S34914001	1	イトキリシリンダササエイタ	THREAD TRIMMER CYLINDER SUPPORT PLATE	
1-2	018400832	2	アナボルト4X8	BOLT, SOCKET M4X8	
1-3	S34913001	1	イトキリシリンダツメ	THREAD TRIMMER CYLINDER CLAW	
1-4	S34910101	1	イトキリリンクレバークミ	THREAD TRIMMER LINK LEVER ASSY	
1-5	S34881001	1	ダンネジM4	STUD SCREW, M4	
1-6	S34906000	1	イトキリウデメタル	THREAD TRIMMER ARM BUSH	
1-7	062260612	2	ナベコ2.6X6	SCREW, PAN M2.6X6	
1-8	S34905101	1	イトキリレバークミ	THREAD TRIMMER LEVER ARM	
1-9	018401022	1	アナボルト4X10	BOLT, SOCKET M4X10	
1-10	S34904001	1	イトキリレバークミピン	LEVER ARM PIN	
1-11	S34903001	1	バネカケ	SPRING HOOK	
1-12	S34883001	1	イトキリバネ	THREAD TRIMMER SPRING	
1-13	S34902001	1	バネカケ	SPRING HOOK	
1-14	021350106	1	1シユナツト35	NUT, 1 M3.5	
1-15	062260406	1	ナベコ26X4	SCREW, PAN M2.6X4	
1-16	S34901001	1	イトキリウデ	THREAD TRIMMER ARM	
1-17	S34900001	1	イトツカミオープナー	THREAD CLAMP OPENER	
1-18	153219001	1	イドウハカラ	MOVABLE KNIFE COLLAR	
1-19	S34899001	1	イドウハクミ	MOVABLE KNIFE ASSY	
1-19-1	S34898001	1	スプリングピン1.4	PIN, SPRING M1.4	
1-20	141542001	3	サラネジ3.18	SCREW, FLAT M3.18	
1-21	S34897001	1	イトサバキ	THREAD HANDLER	
1-22	S01694001	1	サラネジ2.38X4	SCREW, FLAT M2.38X4	
1-23	S34896001	1	コテイハダイ	FIXED KNIFE BRACKET	
1-24	061300416	2	サラコM3X4	SCREW, FLAT M3X4	
1-25	S34895001	1	コテイハ	FIXED KNIFE	
1-26	018260832	2	アナボルト26X8	BOLT, SOCKET M26X8	
1-27	S34894001	1	イトアンナイイタ	THREAD GUIDE PLATE	
1-28	S34893001	1	コテイハトリツケダイ	FIXED KNIFE SET BRACKET	
1-29	062300512	2	ナベコ3X5	SCREW, PAN M3X5	
1-30	S3489101	1	イトツカミクミ	THREAD CLAMP ASSY	
1-30-1	S34890001	1	イトツカミU	THREAD CLAMP (U)	
1-30-2	S34891101	1	イトツカミD	THREAD CLAMP (D)	
1-30-3	S34888101	1	イトツカミM	THREAD CLAMP (M)	
1-30-4	S34892001	1	イトツカミオープナーピン	THREAD CLAMP OPENER PIN	
1-30-5	062020416	2	ナベコ2X4	SCREW, PAN M2X4	
1-30-6	021020106	2	ナツト1シユ2	NUT, 1 M2	
1-31	542515001	2	シメネジ2.6X3.5	SCREW, M2.6X3.5	
1-32	S34887001	1	コテイハオサエバネ	FIXED KNIFE PRESSER SPRING	
1-33	S34886001	1	コテイハオサエバネU	FIXED KNIFE PRESSER SPRING (U)	
1-34	S34885001	1	オサエプレートU	PRESSER PLATE (U)	
1-35	004401003	2	+サラネジ4X10	SCREW, FLAT M4X10	
1-36	152904001	1	シメネジ4.37	SCREW, M4.37	
1-37	104336003	1	シメネジ2.38	SCREW, M2.38	
1-38	S34884000	1	オープナーバネ	OPENER SPRING	
1-39	060630312	2	バインド238-56X3	SCREW, BIND M2.38-56X3	
1-40	021400202	1	2シユナツト4	NUT, 2 M4	
1-41	062300416	2	ナベコM3X4	SCREW, PAN M3X4	

L2. 二重環ルーパ関係(ジーンズ仕様) / Double chain stitch looper mechanism(Jeans specification) / Doppelkettenstichgreifer(Jeans-Ausführung) / Mécanisme du boucleur pour point de chaînette double(Spécifications pour les Jeans) / Mecanismo del presilladora de double cadeneta(Especificación para Jeans)

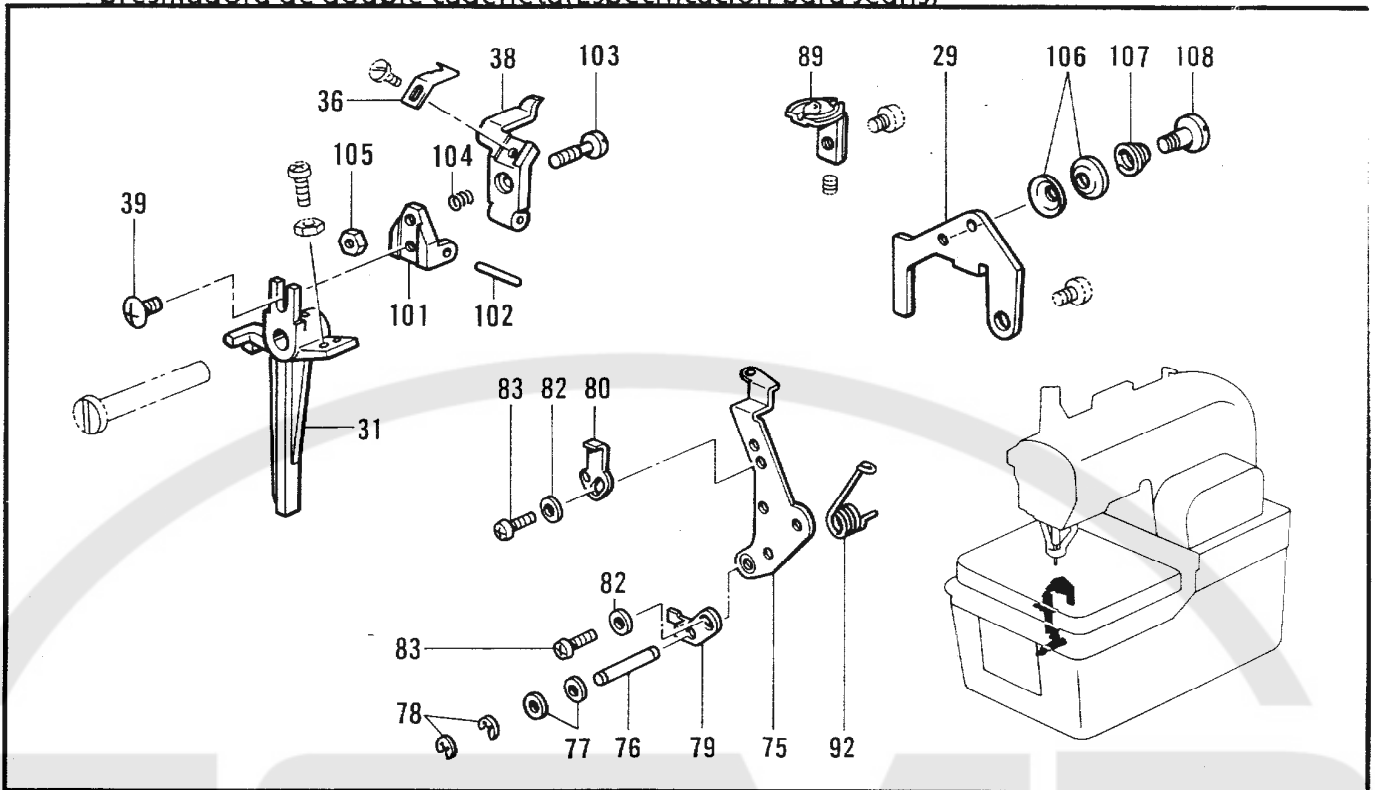

118-980-309

R2. 糸切り関係(ジーンズ仕様) / Thread trimmer mechanism(Jeans specification) / Fadenabschneidevorrichtung(Jeans-Ausführung) / Mécanisme de coupe-fil(Spécifications pour les Jeans) / Mecanismo de la cortadura de hiros(Especificación para Jeans)

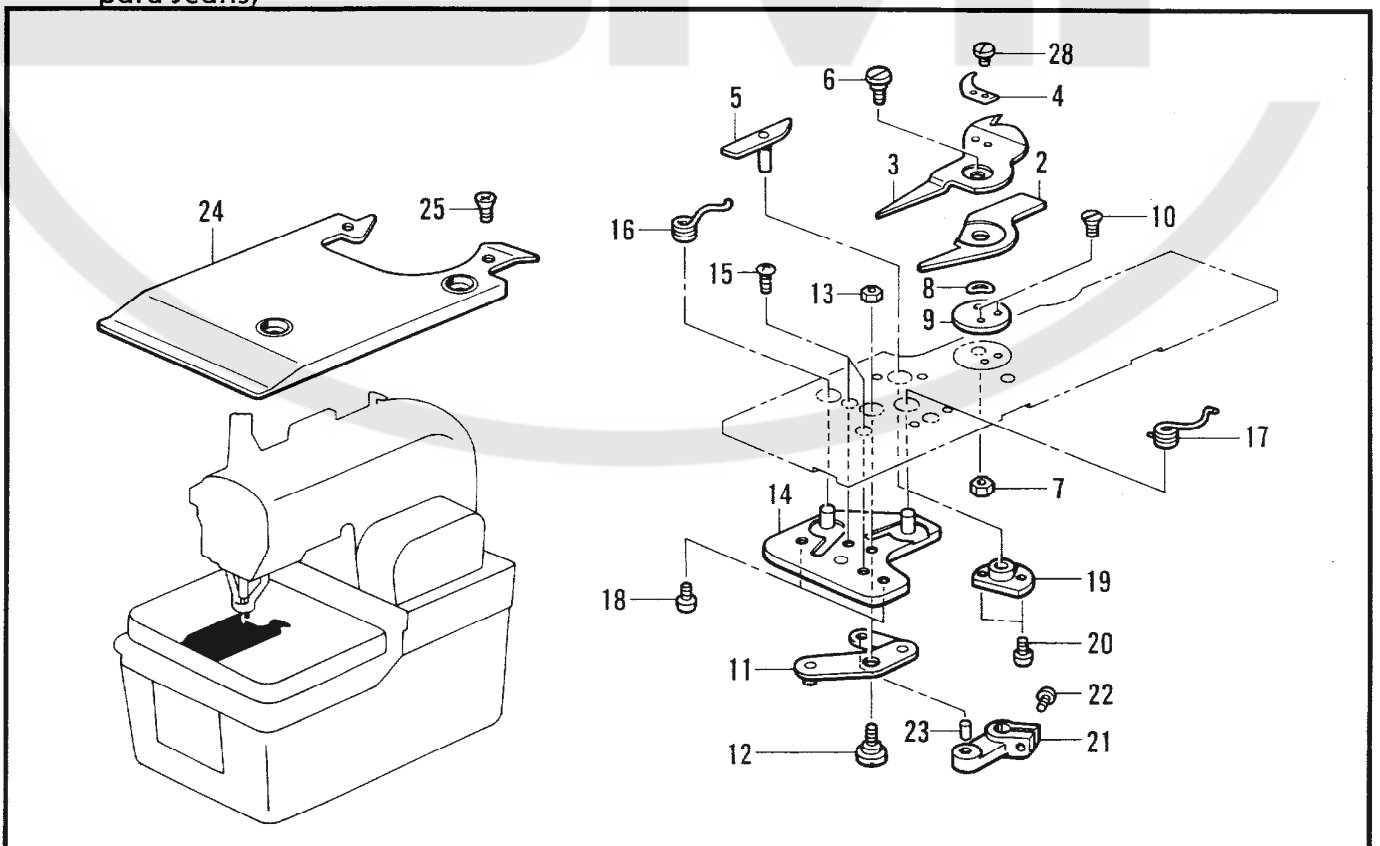

118-980-403

L2. 二重環ルーパ関係(ジーンズ仕様) / Double chain stitch looper mechanism(Jeans specification) / Doppelkettenstichgreifer(Jeans-Ausführung) / Mécanisme du boucleur pour point de chaînette double(Spécifications pour les Jeans) / Mecanismo del presilladora de doble cadeneta(Especificación para Jeans)

REF.NO.	CODE	Q'TY	ヒンメイ	NAME OF PARTS	RM
29	S37696001	1	シンイトアンナイC-J	GIMP GUIDE (C-J)	
31	S37726001	1	イトキリレバードダイB	THREAD TRIMMER LEVER BRACKET (B)	
36	S37723001	1	ウワイドウハB	UPPER MOVABLE KNIFE (B)	
38	S37720001	1	シタイトオサエ	LOWER THREAD PRESSER	
39	060350616	1	バインド3.5X6	SCREW, BIND M3.5X6	
75	S35048101	1	イトユルメレバー	TENSION RELEASE LEVER	
76	S35049001	1	イトユルメレバージク	TENSION RELEASE LEVER SHAFT	
77	025680132	2	ヒラザガネシヨウ4.37	WASHER, PLAIN S 4.37	
78	048030342	2	トメワE3	RETAINING RING, E3	
79	S35050001	1	ルーパーイトユルメ	LOOPER TENSION RELEASE	
80	S35051001	1	イトユルメチヨウセツイタ	TENSION RELEASE PLATE	
82	025350236	2	ヒラザガネチユウ3.5	WASHER, PLAIN M 3.5	
83	062350516	2	ナベコ3.5X5	SCREW, PAN M3.5X5	
89	S37752001	1	スロートプレート1.8-J	THROAT PLATE 1.8(J)	
92	S35057001	1	イトユルメレバーバネ	THREAD RELEASE LEVER SPRING	
101	S37721001	1	シタイトオサエダイ	LOWER THREAD PRESSER BRACKET	
102	148407001	1	ヨコアンナイミゾピンL	DOWEL PIN (L)	
103	S37724001	1	シメネジ2.38	SCREW, M2.38	
104	S37725001	1	シタイトオサエバネ	LOWER THREAD PRESSER SPRING	
105	021630102	1	ナツト1シユ2.	NUT, 1 M2	
106	S35120001	2	ハライトアンナイサラ	THREAD GUIDE DISC	
107	S35118001	1	ハライトチヨウシバネ	TENSION SPRING	
108	S35119001	1	ハライトダンネジ3.18	STUD SCREW 3.18	

118-980-309

R2. 糸切り関係(ジーンズ仕様) / Thread trimmer mechanism(Jeans specification) / Fadenabschneidevorrichtung(Jeans-Ausführung) / Mécanisme de coupe-fil(Spécifications pour les Jeans) / Mecanismo de la cortadura de hiros(Especificación para Jeans)

REF.NO.	CODE	Q'TY	ヒンメイ	NAME OF PARTS	RM
<L1 14-18mm>					
2	S37673001	1	イドウハL1R	MOVABLE KNIFE (L1)(R)	
3	S37669001	1	イドウハL1L	MOVABLE KNIFE (L1)(L)	
4	S37665000	1	イトサバキL1	THREAD HANDLER L1	
5	S37661001	1	イドウハクドウカムL1	MOVABLE KNIFE DRIVING CAM (L1)	
<L2 18-22mm>					
2	S37674001	1	イドウハL2R	MOVABLE KNIFE (L2)(R)	
3	S37670001	1	イドウハL2L	MOVABLE KNIFE (L2)(L)	
4	S37666000	1	イトサバキL2	THREAD HANDLER L2	
5	S37662001	1	イドウハクドウカムL2	MOVABLE KNIFE DRIVING CAM (L2)	
<L3 22-26mm>					
2	S37675001	1	イドウハL3R	MOVABLE KNIFE (L3)(R)	
3	S37671001	1	イドウハL3L	MOVABLE KNIFE (L3)(L)	
4	S37667000	1	イトサバキL3	THREAD HANDLER L3	
5	S37663001	1	イドウハクドウカムL3	MOVABLE KNIFE DRIVING CAM (L3)	
<L4 26-30mm>					
2	S37676001	1	イドウハL4R	MOVABLE KNIFE (L4)(R)	
3	S37672001	1	イドウハL4L	MOVABLE KNIFE (L4)(L)	
4	S37668000	1	イトサバキL4	THREAD HANDLER L4	
5	S37664001	1	イドウハクドウカムL4	MOVABLE KNIFE DRIVING CAM (L4)	
6	S37660001	1	ダンネジM4	SHOULDER SCREW, M4	
7	021400202	1	2シユナツト4	NUT, 2 M4	
8	S37654000	1	ナミザガネ	WASHER, WAVE	
9	S37655001	1	メスササエザガネ	KNIFE SUPPORT WASHER	
10	141542001	2	サラネジ3.18	SCREW, FLAT M3.18	
11	S37656001	1	イトキリリンクレバーJクミ	THREAD TRIMMER LINK LEVER (J) ASSY	
12	S34881001	1	ダンネジM4	SHOULDER SCREW, M4	
13	021400202	1	2シユナツト4	NUT, 2 M4	
14	S37820001	1	リンクシテンプレートクミ	LINK FURCRUM PLATE ASSY	
15	062400616	2	ナベコM4X6	SCREW, PAN M4X6	
16	S37652001	1	モドシバネL	SPRING (L)	
17	S37653001	1	モドシバネR	SPRING (R)	
18	062300416	2	ナベコM3X4	SCREW, PAN M3X4	
19	S34906000	1	イトキリウデメタル	THREAD TRIMMER ARM BUSH	
20	062260612	2	ナベコ2.6X6	SCREW, PAN M2.6X6	
21	S37659001	1	イトキリレバーウデB	THREAD CUTTER LEVER ARM (B)	
22	018401022	1	アナボルト4X10	BOLT, SOCKET M4X10	
23	S37858000	1	ニードルピン4X8	NEEDLE PIN 4X8	
24	S37700001	1	オサエプレートU	PRESSER PLATE (U)	
25	004401003	2	+サラネジ4X10	SCREW, FLAT M4X10	
28	153787001	2	シメネジ2.38	SCREW, M2.38	

118-980-403

S. 上糸切り関係 / Upper thread trimmer mechanism / Oberer Fadenabschneider /
 Mécanisme de la coupe-fil supérieur / Mecanismo de la recortadora de orillos superior

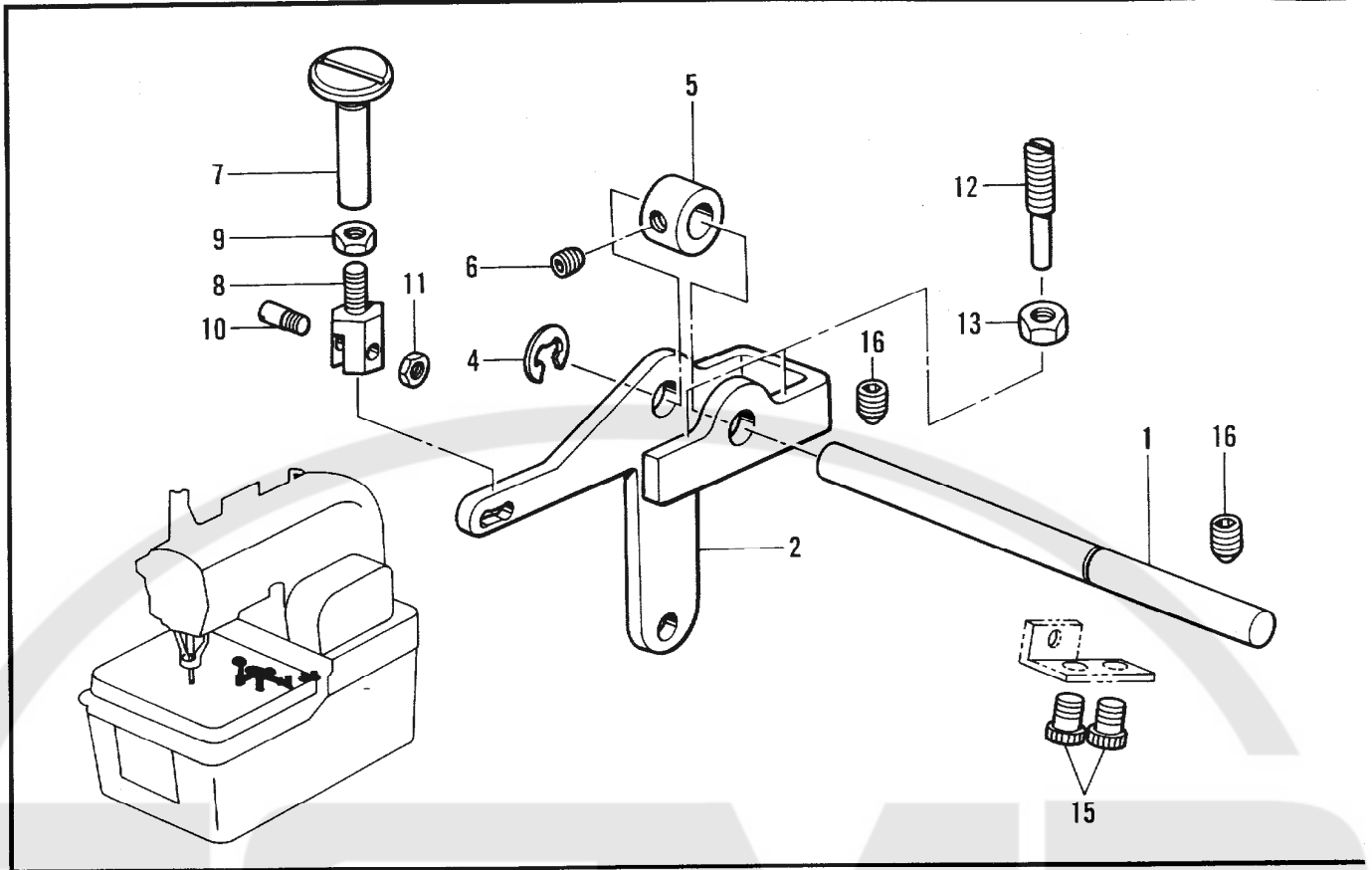

118-980-409

T. 針位置検出器関係 / Synchronizer / Synchronisator / Synchronisateur / Sincronizador

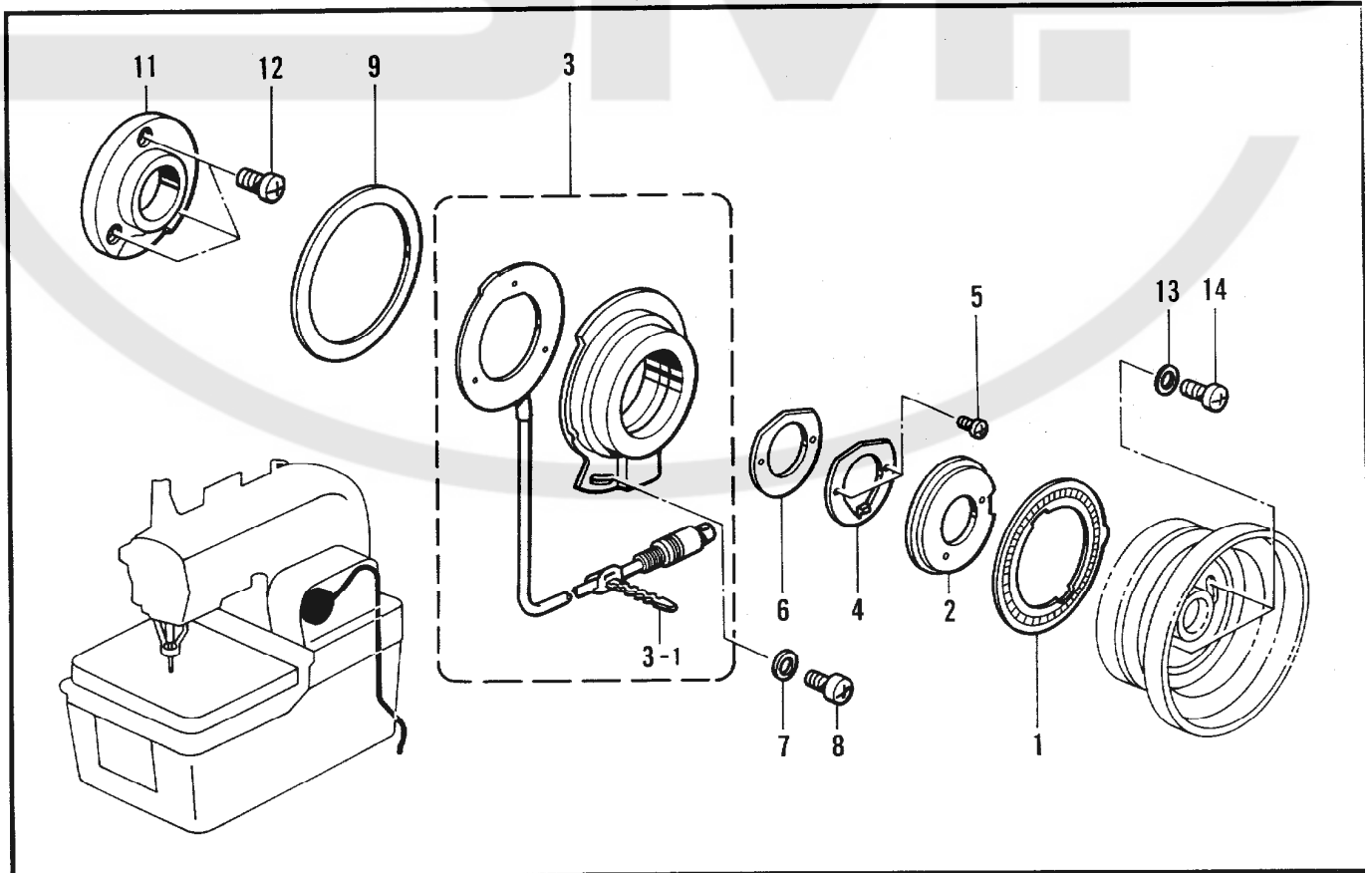

118-980-501

S. 上糸切り関係 / Upper thread trimmer mechanism / Oberer Fadenabschneider /
Mécanisme de la coupe-fil supérieur / Mecanismo de la recortadora de orillos superior

REF.NO.	CODE	Q'TY	ヒンメイ	NAME OF PARTS	RM
1	S35058001	1	イトキリレバージク	THREAD TRIMMER LEVER SHAFT	
2	S35059001	1	イトキリレバー	THREAD TRIMMER LEVER	
4	048050342	1	トメワE5	RETAINING RING, E5	
5	S35060001	1	セットカラー	SET COLLAR	
6	014400432	1	アナクボミ4X4	SET SCREW, SOCKET (CP) M4X4	
7	S35361001	1	イトキリレバーハンマ	THREAD TRIMMER LEVER HAMMER	
8	S35362001	1	イトキリチヨウセツネジ	THREAD TRIMMER ADJUST SCREW	
9	021350106	1	1シユナツト35	NUT, 1 M3.5	
10	S35235001	1	クランプササエピン	CLAMP SUPPORT PIN	
11	021300302	1	3シユナツト3	NUT, 3 M3	
12	S35364001	2	トメネジ4X26	SET SCREW, M4X26	
13	021400202	2	2シユナツト4	NUT, 2 M4	
15	018401022	2	アナボルト4X10	BOLT, SOCKET M4X10	
16	014060632	2	アナトメ6X6クボミ	SET SCREW, SOCKET (CP) M6X6	

118-980-409

T. 針位置検出器関係 / Synchronizer / Synchronisator / Synchronisateur / Sincronizador

REF.NO.	CODE	Q'TY	ヒンメイ	NAME OF PARTS	RM
1	S34945000	1	ソクドシレイイタ64	SPEED COMMAND PLATE 64	
2	S34946001	1	テイシシレイイタ	STOP COMMAND PLATE	
3	237941001	1	シンクロナイザクミ#13G7	SYNCHRONIZER ASSY (#13G7)	
3-1	226391001	1	コードバンド	CORD BAND	
4	S02687201	1	ケンシユツキオサエ	SYNCHRONIZER SUPPORT	
5	062020805	2	ナベコ2X8	SCREW, PAN M2X8	
6	S07885000	1	ケンシユツキオサエパツキン	SYNCHRONIZER SUPPORT PACKING	
7	113431002	1	ザガネ	WASHER	
8	062501006	1	ナベコ5X10	SCREW, PAN M5X10	
9	S03327000	1	シンクロナイザパツキン	SYNCHRONIZER PACKING	
11	S34947001	1	NPササエダイ	NP SUPPORT BRACKET	
12	062401016	3	ナベコ4X10	SCREW, PAN M4X10	
13	025040232	2	ヒラザガネチユウ4	WASHER, PLAIN M 4	
14	062401616	2	ナベコ4X16	SCREW, PAN M4X16	

118-980-501

U . 空圧関係 / Air pressure mechanism / Luftdruck /
 Mécanisme de la pression d'air / Mecanismo de la presión de aire

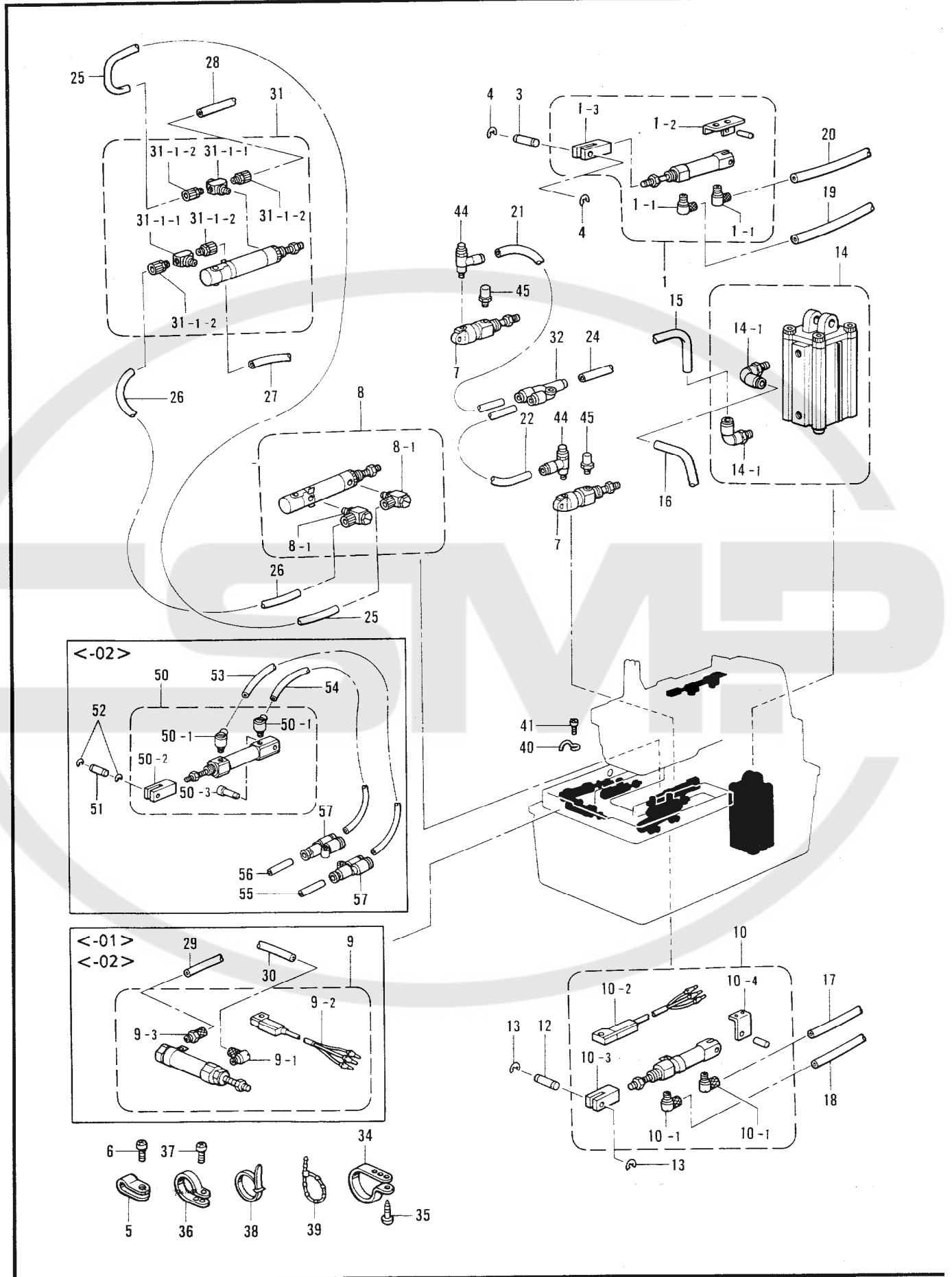

U. 空圧関係 / Air pressure mechanism / Luftdruck /
Mécanisme de la pression d'air / Mecanismo de la presión de aire

REF.NO.	CODE	Q'TY	ヒンメイ	NAME OF PARTS	RM
1	S35349101	1	シリンダ10X15クミ	CYLINDER 10X15 ASSY	
1-1	S12150000	2	ホースエルボM-5HL-4	TUBE ELBOW (M-5HL-4)	
1-2	S34925101	1	イトユルメシリンダササエ	THREAD RELEASE CYLINDER SUPPORT	
1-3	S35351001	1	シリンダロッド	CYLINDER ROD	
3	S35305001	1	シリンダロッドピン	CYLINDER ROD PIN	
4	048030342	2	トメワE3	RETAINING RING, E3	
5	S10243000	1	ナイロンクランプNK-3N	CORD HOLDER (NK-3N)	
6	062400812	1	ナベコ4X8	SCREW, PAN M4X8	
7	S35350000	2	シリンダ16X10	CYLINDER 16X10	
8	S35358000	1	シリンダ16X15クミA	CYLINDER 16X15 ASSY (A)	
8-1	S35359000	2	ユニバーサルエルボ	UNIVERSAL ELBOW	
10	S35352001	1	シリンダ10X15Sクミ	CYLINDER 10X15 (S) ASSY	
10-1	S12150000	2	ホースエルボM-5HL-4	TUBE ELBOW (M-5HL-4)	
10-2	S35397000	1	ウワイトキリセンサ	UPPER THREAD TRIMMER SENSOR	
10-3	S35351001	1	シリンダロッド	CYLINDER ROD	
10-4	S34916001	1	シリンダササエ	CYLINDER SUPPORT	
12	S35305001	1	シリンダロッドピン	CYLINDER ROD PIN	
13	048030342	2	トメワE3	RETAINING RING, E3	
14	S35360000	1	シリンダ63X100クミ	CYLINDER 63X100 ASSY	
14-1	S35426000	2	エルボ10-4	ELBOW 10-4	
15	S35417000	1	エアーホース10X6.5-11(L=1100)	AIR TUBE 10X6.5-11 (L=1100)	
16	S35909000	1	エアーホース10X6.5-18(L=1100)	AIR TUBE 10X6.5-18 (L=1100)	
17	S35367000	1	エアーホース4X2.5-9(L=1130)	AIR TUBE 4X2.5X-9 (L=1130)	
18	S35368000	1	エアーホース4X2.5-10(L=1090)	AIR TUBE 4X2.5-10 (L=1090)	
19	S35369000	1	エアーホース4X2.5-7(L=1150)	AIR TUBE 4X2.5-7 (L=1150)	
20	S35370000	1	エアーホース4X2.5-8(L=1100)	AIR TUBE 4X2.5-8 (L=1100)	
21	S35371000	1	エアーホース4X2.5-14(L=1370)	AIR TUBE 4X2.5-14 (L=1370)	
22	S35372000	1	エアーホース4X2.5-17(L=1595)	AIR TUBE 4X2.5-17 (L=1595)	
24	S35374000	1	エアーホース4X2.5-1(L=100)	AIR TUBE 4X2.5-1 (L=100)	
25	S35375000	1	エアーホース4X2.5-12(L=360)	AIR TUBE 4X2.5-12 (L=360)	
26	S35376000	1	エアーホース4X2.5-13(L=320)	AIR TUBE 4X2.5-13 (L=320)	
27	S35377000	1	エアーホース4X2.5-3(L=1405)	AIR TUBE 4X2.5-3 (L=1405)	
28	S35378000	1	エアーホース4X2.5-4(L=1355)	AIR TUBE 4X2.5-4 (L=1355)	
31	S35355000	1	シリンダ16X15クミB	CYLINDER ASSY 16X15 ASSY (B)	
31-1	S35354000	2	ホースニツブルクミ	TUBE NIPPLE ASSY	
31-1-1	S35356000	1	ユニバーサルチー	UNIVERSAL T-JOINT	
31-1-2	S35357000	2	ストレートツギテ5	STRAIGHT JOINT 5	
32	S12104000	1	ユニオンワイ4	UNION-Y 4	
34	158581000	2	コードホルダ#24	CORD HOLDER (24N)	
35	032422003	2	+マルモクネジ4.1X20	WOOD SCREW, ROUND M4.1X20	
36	S11817000	1	クランプNK-18N	CLAMP NK-18N	
37	062400816	1	ナベコ4X8	SCREW, PAN M4X8	
38	S04557000	7	バンタイPLTIM	BAND PLTIM	
39	340400001	4	ユニタイバンド	BEAD BAND	
40	152969001	1	コードササエカネ	CORD SUPPORT	
41	062350616	1	ナベコM3.5X6	SCREW, PAN M3.5X6	
44	S35460000	2	スピコン	SPEED CONTROLLER	
45	S13955000	2	エアマフラ	AIR BOLSTER	
<-01><上下糸切り用/ FOR UPPER AND LOWER THREAD TRIMMER>					
<-02><ジーンズ仕様/JEANS SPECIFICATION>					
9	S35353000	1	シリンダ16X30クミ	CYLINDER 16X30 ASSY	
9-1	S12150000	1	ホースエルボM-5HL-4	TUBE ELBOW (M-5HL-4)	
9-2	S35396000	1	シタイトキリセンサ	LOWER THREAD TRIMMER SENSOR	
9-3	S11433000	1	ホースニツブル4M5	HOSE NIPPLE (4M5)	
29	S35398000	1	エアーホース4X2.5-5(L=1440)	AIR TUBE 4X2.5-5 (L=1440)	
30	S35399000	1	エアーホース4X2.5-6(L=1490)	AIR TUBE 4X2.5-6 (L=1490)	
<-02><ジーンズ仕様/JEANS SPECIFICATION>					
50	S37737001	1	シリンダ10X15Jクミ	CYLINDER	
50-1	S12150000	2	ホースエルボM-5HL-4	TUBE ELBOW (M-5HL-4)	
50-2	S35351-001	1	シリンダロッド	CYLINDER ROD	
50-3	S37866-000	1	クレビスピン	CLEVIS PIN	
51	S35305001	1	シリンダロッドピン	CYLINDER ROD PIN	
52	048030342	2	トメワE3	RETAINING RING, E3	
53	S37738000	1	エアーホース4X2.5-20	AIR TUBE 4X2.5-20 (L=1350)	
54	S37739000	1	エアーホース4X2.5-21	AIR TUBE 4X2.5-21 (L=1400)	
55	S37863000	1	エアーホース4X2.5-3J	AIR TUBE 4X2.5-21 (L=100)	
56	S37864000	1	エアーホース4X2.5-4J	AIR TUBE 4X2.5-21 (L=100)	
57	S12104000	2	ユニオンワイ4	UNION-Y 4	

U. 空圧関係 / Air pressure mechanism / Luftdruck /
 Mécanisme de la pression d'air / Mecanismo de la presión de aire

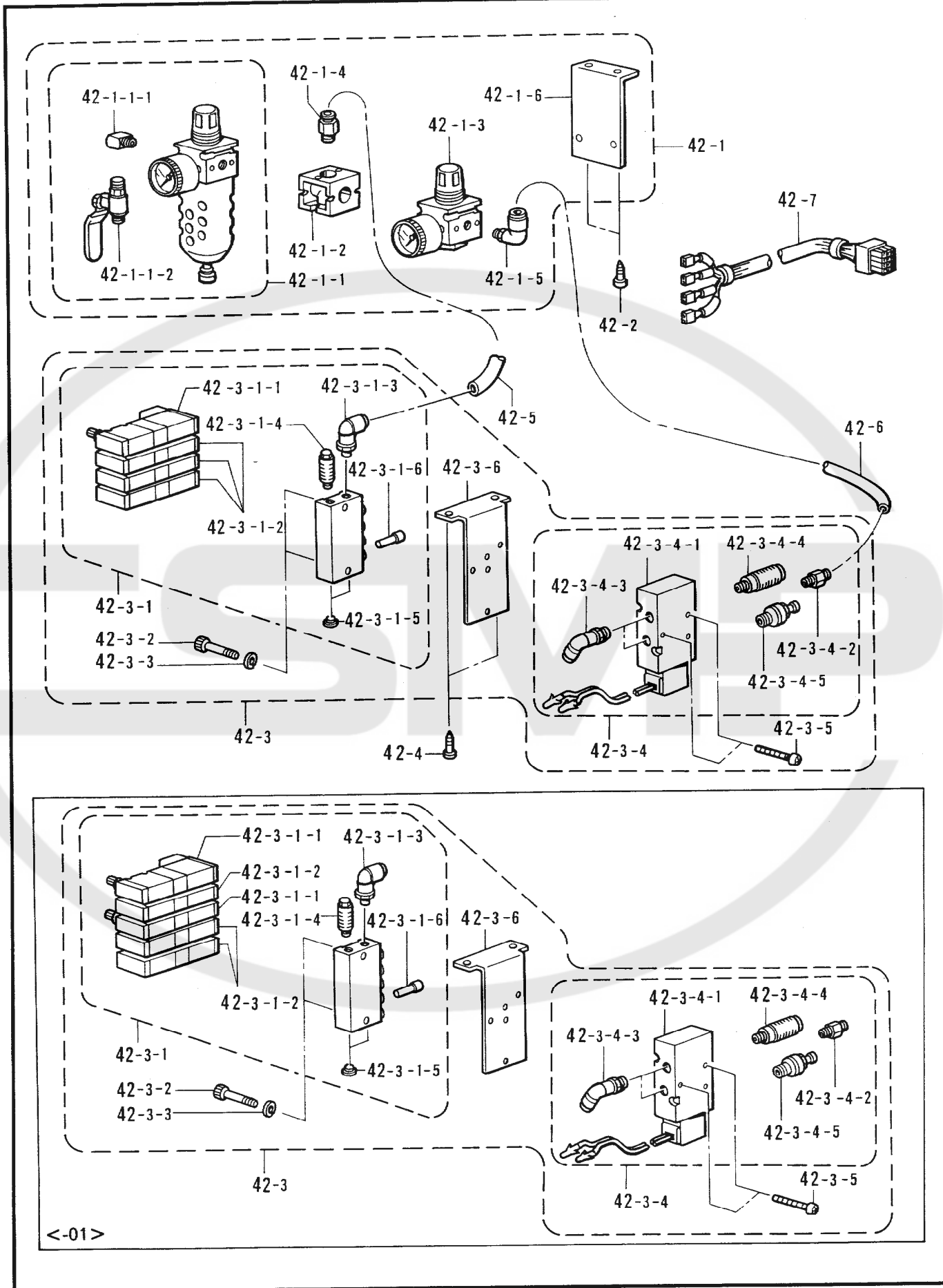

<-01>

U. 空圧関係 / Air pressure mechanism / Luftdruck /
Mécanisme de la pression d'air / Mecanismo de la presión de aire

REF.NO.	CODE	Q'TY	ヒンメイ	NAME OF PARTS	RM
42-1	S35389001	1	エアーユニットクミ	AIR UNIT ASSY	
42-1-1	S35386000	1	FRユニットクミ	(FR) UNIT ASSY	
42-1-1-1	S32354000	1	PTチーズ1/4	PT-JOINT 1/4	
42-1-1-2	S09231000	1	ボールバルブ1/4	BALL VALVE (1/4)	
42-1-2	S35382000	1	ダイバータ	DIVERTER	
42-1-3	S35395000	1	レギュレータR55	REGULATOR (R55)	
42-1-4	S35423000	1	コネクタ10-3/8	CONNECTOR 10-3/8	
42-1-5	S35424000	1	エルボ10-1/4	ELBOW 10-1/4	
42-1-6	S35425001	1	エアーユニットトリツケイタ	AIR UNIT SET PLATE	
42-2	031553202	2	マルモクネジ5.5X32	WOOD SCREW, ROUND M5.5X32	
42-4	031553202	2	マルモクネジ5.5X32	WOOD SCREW, ROUND M5.5X32	
42-5	S35379100	1	エアーホース10X6.5-15 (L = 780)	AIR TUBE 10X6.5-15 (L = 780)	
42-6	S35380100	1	エアーホース10X6.5-16 (L = 710)	AIR TUBE 10X6.5-16 (L = 710)	
42-7	S35151100	1	バルブハーネス	VALVE HARNESS	
<-00> <上糸切り用 / FOR UPPER THREAD TRIMMER>					
42	S35461001	1	エアーユニットソウクミB	AIR UNIT SET (B)	
42-3	S35462101	1	バルブユニットクミ	VALVE UNIT ASSY	
42-3-1	S35463000	1	ソレノイドバルブクミ	SOLENOID VALVE ASSY	
42-3-1-1	S12160000	1	バルブVZ3153-N	VALVE VZ3153-N	
42-3-1-2	S12161000	3	バルブVZ3143	VALVE VZ3143	
42-3-1-3	S35383000	1	エルボユニオン10-1/8	ELBOW UNION 10-1/8	
42-3-1-4	140682001	1	サイレンサン	SILENCER	
42-3-1-5	153274001	2	1/8トメセン	CAP 1/8	
42-3-1-6	S04897000	1	プラグ4	PLUG 4	
42-3-2	018503036	2	アナボルト5X30	BOLT, SOCKET M5X30	
42-3-3	028050243	2	バネザガネ2-5	WASHER, SPRING 2-5	
42-3-4	S35384100	1	バルブクミ	VALVE ASSY	
42-3-4-1	S36753000	1	バルブVF5120	VALVE (VF5120)	
42-3-4-2	S36744000	1	ハーフユニオン10-3/8	HALF UNION 10-3/8	
42-3-4-3	S36743000	2	エルボ10-3/8	ELBOW 10-3/8	
42-3-4-4	S36742000	1	サイレンサー	SILENCER	
42-3-4-5	S36532100	1	ハイキシボリ3/8	EXHAUST THROTTLE VALVE 3/8	
42-3-5	062403515	2	ナベコ4X35	SCREW, PAN M4X35	
42-3-6	S35394001	1	バルブトリツケダイ	VALVE SET BRACKET	
<-01> <上下糸切り用 / FOR UPPER AND LOWER THREAD TRIMMER>					
42	S35422001	1	エアーユニットソウクミア	AIR UNIT SET (A)	
42-3	S35390101	1	バルブユニットクミ	VALVE UNIT ASSY	
42-3-1	S35393000	1	ソレノイドバルブクミ	SOLENOID VALVE ASSY	
42-3-1-1	S12160000	2	バルブVZ3153-N	VALVE VZ3153-N	
42-3-1-2	S12161000	3	バルブVZ3143	VALVE VZ3143	
42-3-1-3	S35383000	1	エルボユニオン10-1/8	ELBOW UNION 10-1/8	
42-3-1-4	140682001	1	サイレンサン	SILENCER	
42-3-1-5	153274001	2	1/8トメセン	CAP 1/8	
42-3-1-6	S04897000	1	プラグ4	PLUG 4	
42-3-2	018503036	2	アナボルト5X30	BOLT, SOCKET M5X30	
42-3-3	028050243	2	バネザガネ2-5	WASHER, SPRING 2-5	
42-3-4	S35384100	1	バルブクミ	VALVE ASSY	
42-3-4-1	S36753000	1	バルブVF5120	VALVE (VF5120)	
42-3-4-2	S36744000	1	ハーフユニオン10-3/8	HALF UNION 10-3/8	
42-3-4-3	S36743000	2	エルボ10-3/8	ELBOW 10-3/8	
42-3-4-4	S36742000	1	サイレンサー	SILENCER	
42-3-4-5	S36532100	1	ハイキシボリ3/8	EXHAUST THROTTLE VALVE 3/8	
42-3-5	062403515	2	ナベコ4X35	SCREW, PAN M4X35	
42-3-6	S35394001	1	バルブトリツケダイ	VALVE SET BRACKET	

V. 電装品関係 / Power supply equipment mechanism / Stromversorgung /
 Mécanisme de l'équipement en alimentation électrique /
 Mecanismo del equipo de alimentación de corriente

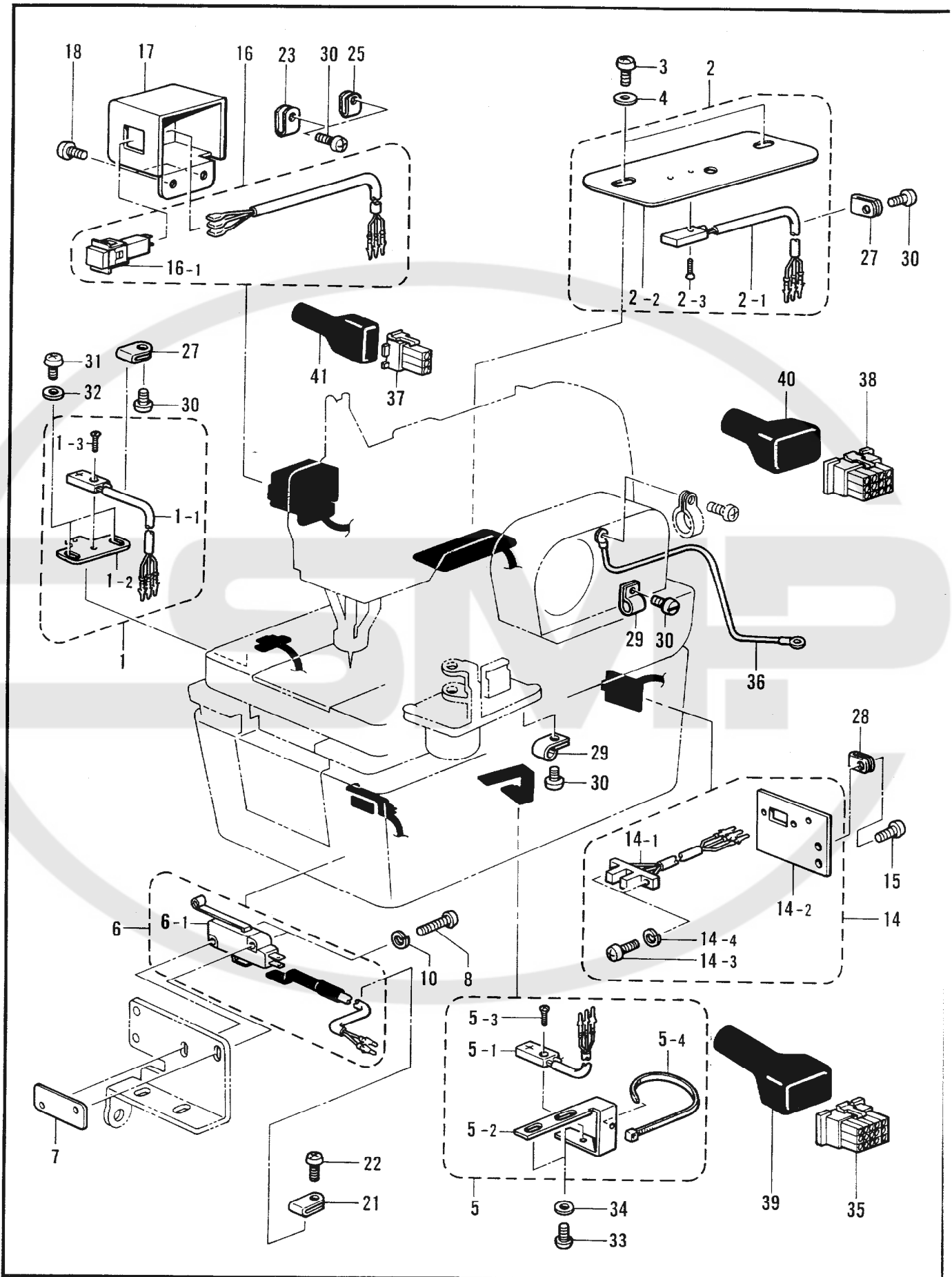

V. 電装品関係 / Power supply equipment mechanism / Stromversorgung /
 Mécanisme de l'équipement en alimentation électrique /
 Mecanismo del equipo de alimentación de corriente

REF.NO.	CODE	Q'TY	ヒンメイ	NAME OF PARTS	RM
1	S35433101	1	Xセンサクミ	X-SENSOR ASSY	
1-1	S35152000	1	Xセンサ	X-SENSOR	
1-2	S35185101	1	Xセンサトリツケイタ	X-SENSOR SET PLATE	
1-3	S10856001	1	+サラネジ2X8	SCREW, FLAT M2X8	
2	S35161001	1	Yセンサクミ	Y-SENSOR ASSY	
2-1	S35153000	1	Yセンサ	Y-SENSOR	
2-2	S10856001	1	+サラネジ2X8	SCREW, FLAT M2X8	
2-3	S35164001	1	Yセンサトリツケイタ	Y-SENSOR SET PLATE	
3	062400812	2	ナベコ4X8	SCREW, PAN M4X8	
4	025040234	2	ヒラザガネチユウ4	WASHER, PLAIN M 4	
5	S35434001	1	Rセンサクミ	R-SENSOR ASSY	
5-1	S35154000	1	Rセンサ	R-SENSOR	
5-2	S35298001	1	Rセンサトリツケイタ	R-SENSOR SET PLATE	
5-3	S10856001	1	+サラネジ2X8	SCREW, FLAT M2X8	
5-4	S04557000	1	バンタイPLTIM	BAND PLTIM	
6	S35160000	1	アンゼンSWクミ	SAFETY SWITCH ASSY	
6-1	S10546000	1	スイッチD2MVローラ	SWITCH (D2MV) ROLLER	
7	S05973001	1	トリツケウライタ	SET PLATE	
8	062301606	2	ナベコM3X16	SCREW, PAN M3X16	
10	028030243	2	バネザガネ2-3	WASHER, SPRING 2-3	
14	S35157001	1	カッターセンサクミ	CUTTER SENSOR ASSY	
14-1	S35158000	1	カッターセンサー	CUTTER SENSOR	
14-2	S35162001	1	カッターセンサトリツケイタ	CUTTER SENSOR SET PLATE	
14-3	062300806	2	ナベコ3X8	SCREW, PAN M3X8	
14-4	028030243	2	バネザガネ2-3	WASHER, SPRING 2-3	
15	062400812	2	ナベコ4X8	SCREW, PAN M4X8	
16	S35159000	1	EMスイッチクミ	EM-SWITCH ASSY	
16-1	S32109000	1	スイッチEB2011G	SWITCH EB2011G	
17	S35165009	1	スイッチカバー	SWITCH COVER	
18	062400812	2	ナベコ4X8	SCREW, PAN M4X8	
21	S11816000	3	クランプNK-2N	CLAMP NK-2N	
22	062400812	3	ナベコ4X8	SCREW, PAN M4X8	
23	S10243000	1	ナイロンクランプNK-3N	CORD HOLDER (NK-3N)	
25	S11816000	1	クランプNK-2N	CLAMP NK-2N	
27	S11816000	2	クランプNK-2N	CLAMP NK-2N	
28	S10243000	1	ナイロンクランプNK-3N	CORD HOLDER (NK-3N)	
29	552907000	2	コードホルダ#10	CORD HOLDER (10N)	
30	062400812	6	ナベコ4X8	SCREW, PAN M4X8	
31	062400812	3	ナベコ4X8	SCREW, PAN M4X8	
32	025040232	2	ヒラザガネチユウ4	WASHER, PLAIN M 4	
33	062400812	2	ナベコ4X8	SCREW, PAN M4X8	
34	025040232	2	ヒラザガネチユウ4	WASHER, PLAIN M 4	
35	S35405000	1	コネクタ172171-1	CONNECTOR (172171-1)	
36	S11730100	1	アースセン700	EARTH WIRE (700)	
37	S36381000	1	コネクタ3P	CONNECTOR (3P)	
38	S36382000	1	コネクタ12P	CONNECTOR (12P)	
39	S36681000	1	コネクタキーキャップ	CONNECTOR CAP	
40	S36682000	1	コネクタキーキャップ	CONNECTOR CAP	
41	143485001	1	コネクタキーキャップ	CONNECTOR CAP	

足踏みスイッチ / Foot switch pedal mechanism / Fußbetaätigung /
 Mécanisme de la pédale / Mecanismo del pedal

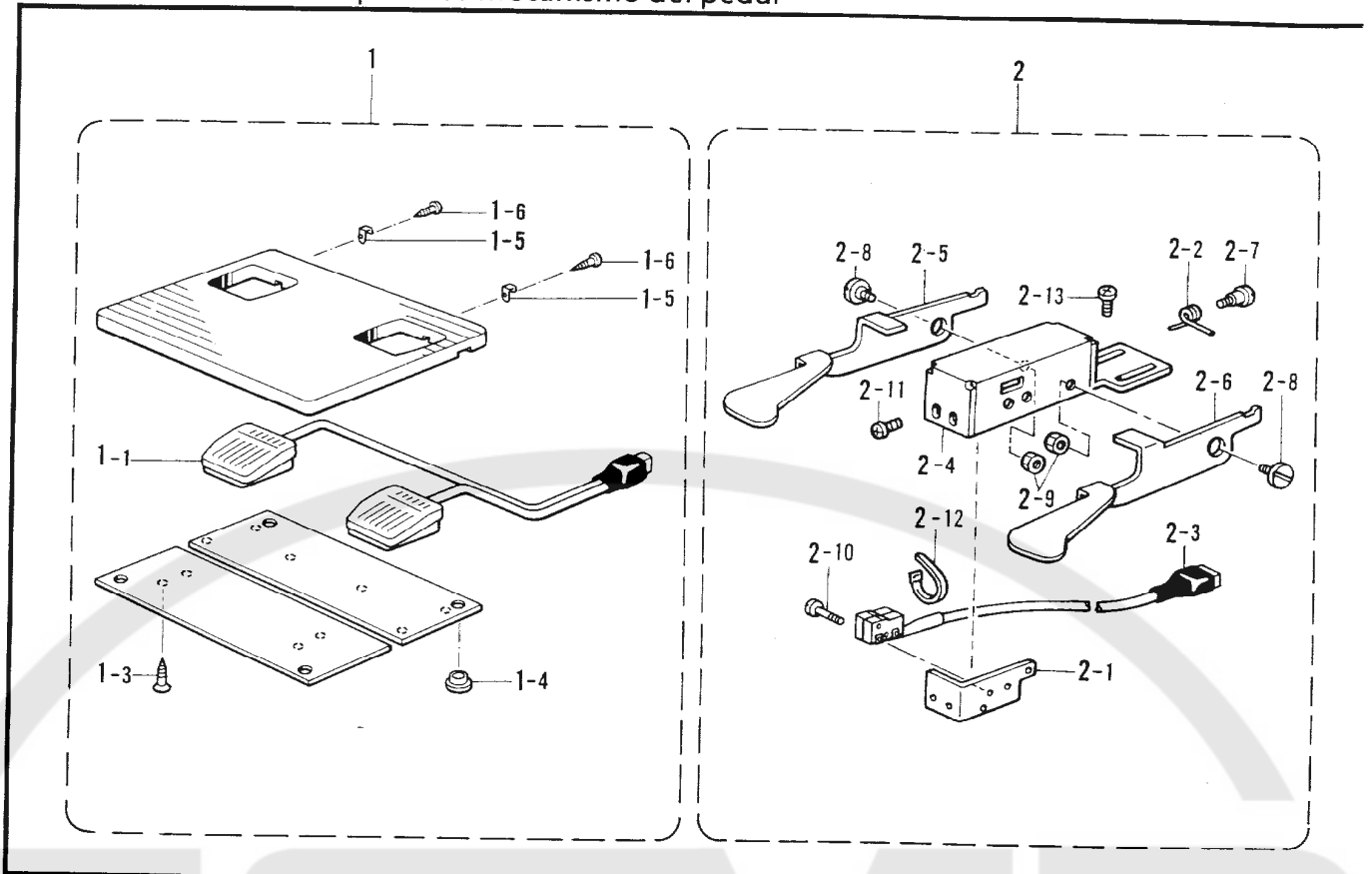

X1. モーター関係 / Motor mechanism / Motor / Mécanisme du moteur / Mecanismo del motor 118-980-651

<オシボタンスイッチクミ / PUSH BUTTON SWITCH ASSY>

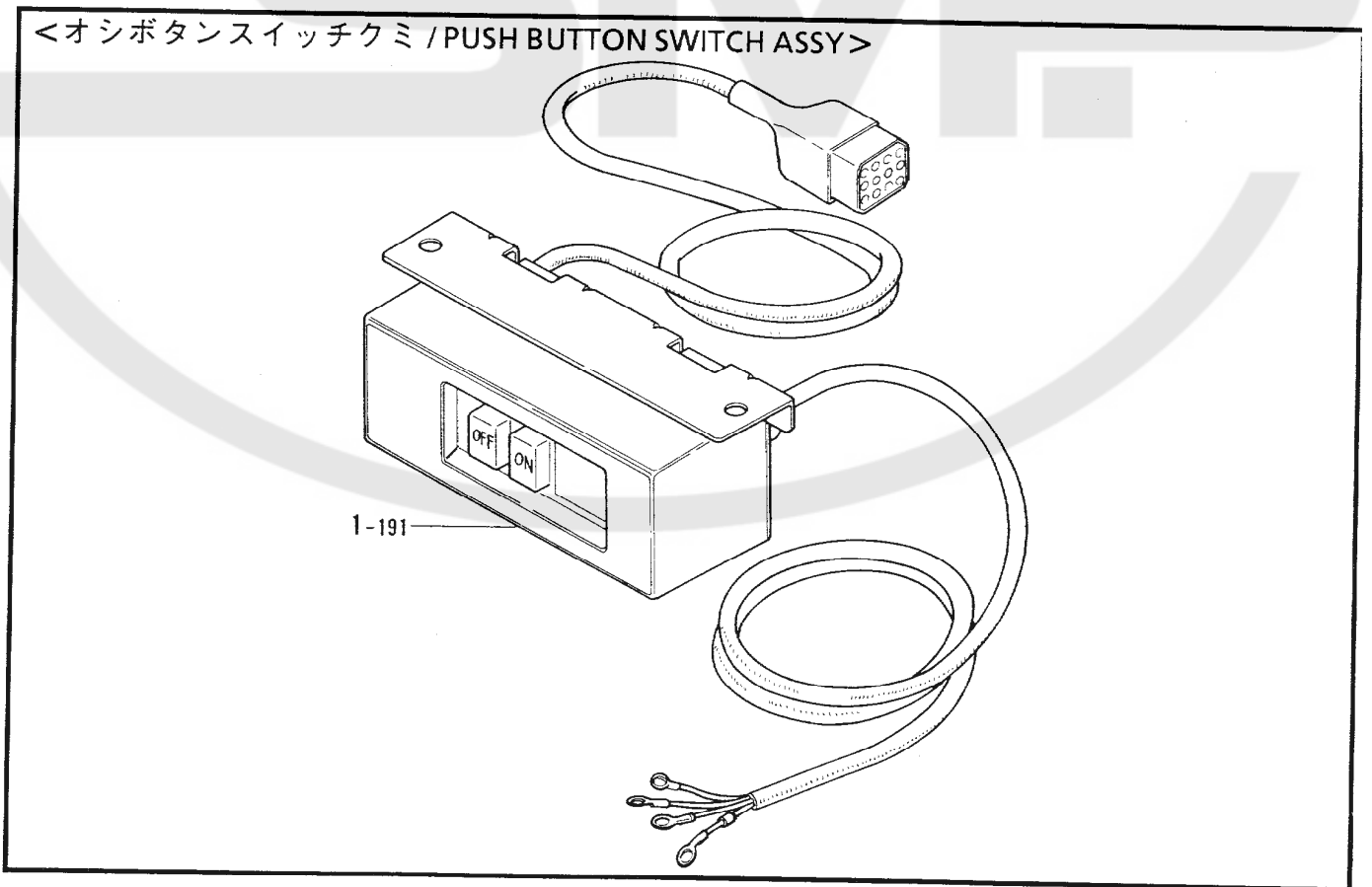

138-980-650

W. 踏板関係 / Foot switch pedal mechanism / Fußbetätigung /
Mécanisme de la pédale / Mecanismo del pedal

REF.NO.	CODE	Q'TY	ヒンメイ	NAME OF PARTS	RM
1	S35004001	1	フットスイッチイタクミ	FOOT SWITCH PLATE ASSY	
1-1	S35005001	1	フットスイッチクミ	FOOT SWITCH ASSY	
1-3	034311302	10	+サラモクネジ3.1X13	WOOD SCREW, FLAT M3.1X13	
1-4	159150009	4	ゴムセン20.5	CAP	
1-5	S01825001	2	フミイタカケ	TREADLE HOOK	
1-6	031312006	2	マルモクネジ3.1X20	WOOD SCREW, ROUND M3.1X20	
<オプションパーツ/OPTION PARTS>					
2	S39909001	1	テモトスイッチクミ	HAND START SWITCH ASSY	
2-1	S39913001	1	スイッチトリツケイタ	SWITCH SET PLATE	
2-2	S39914001	1	スイッチレバーバネ	SWITCH LEVER SPRING	
2-3	S39915000	1	テモトスイッチ	HAND SWITCH	
2-4	S39910001	1	スイッチカバー	SWITCH COVER	
2-5	S39911001	1	スイッチレバーL	SWITCH LEVER (L)	
2-6	S39912001	1	スイッチレバーR	SWITCH LEVER (R)	
2-7	S34922101	1	ダンネジM4	STUD SCREW, M4	
2-8	S34966001	2	ダンネジM4	STUD SCREW, M4	
2-9	021400202	3	2シュナット4	NUT, 2M4	
2-10	146124001	2	シメネジ2.38	SCREW, M2.38	
2-11	060300616	2	バインド3X6	SCREW, BIND M3X6	
2-12	S04557000	1	バンドイPLTIM	BAND PLTIM	
2-13	060400816	2	バインド4X8	SCREW, BIND M4X8	

118-980-651

X1. モーター関係 / Motor mechanism / Motor / Mécanisme du moteur / Mecanismo del motor

REF.NO.	CODE	Q'TY	ヒンメイ	NAME OF PARTS	RM
<単相><100V>					
1-191	S36885001	1	オシボタンスイッチクミ	-----	
<三相><200V>					
1-191	S36886001		オシボタンスイッチクミ	-----	
<1 PHASE>					
<110V>					
1-191	S36887001		-----	PUSH BUTTON SWITCH ASSY	
<200V,220V>					
1-191	S36888001		-----	PUSH BUTTON SWITCH ASSY	
<230V,240V>					
1-191	S36889001		-----	PUSH BUTTON SWITCH ASSY	
<3 PHASE>					
<220V>					
1-191	S36890001		-----	PUSH BUTTON SWITCH ASSY	
<380V,415V>					
1-191	S36891001		-----	PUSH BUTTON SWITCH ASSY	

138-980-650

X2. モータ関係 / Motor mechanism / Motor / Mécanisme du moteur / Mecanismo del motor

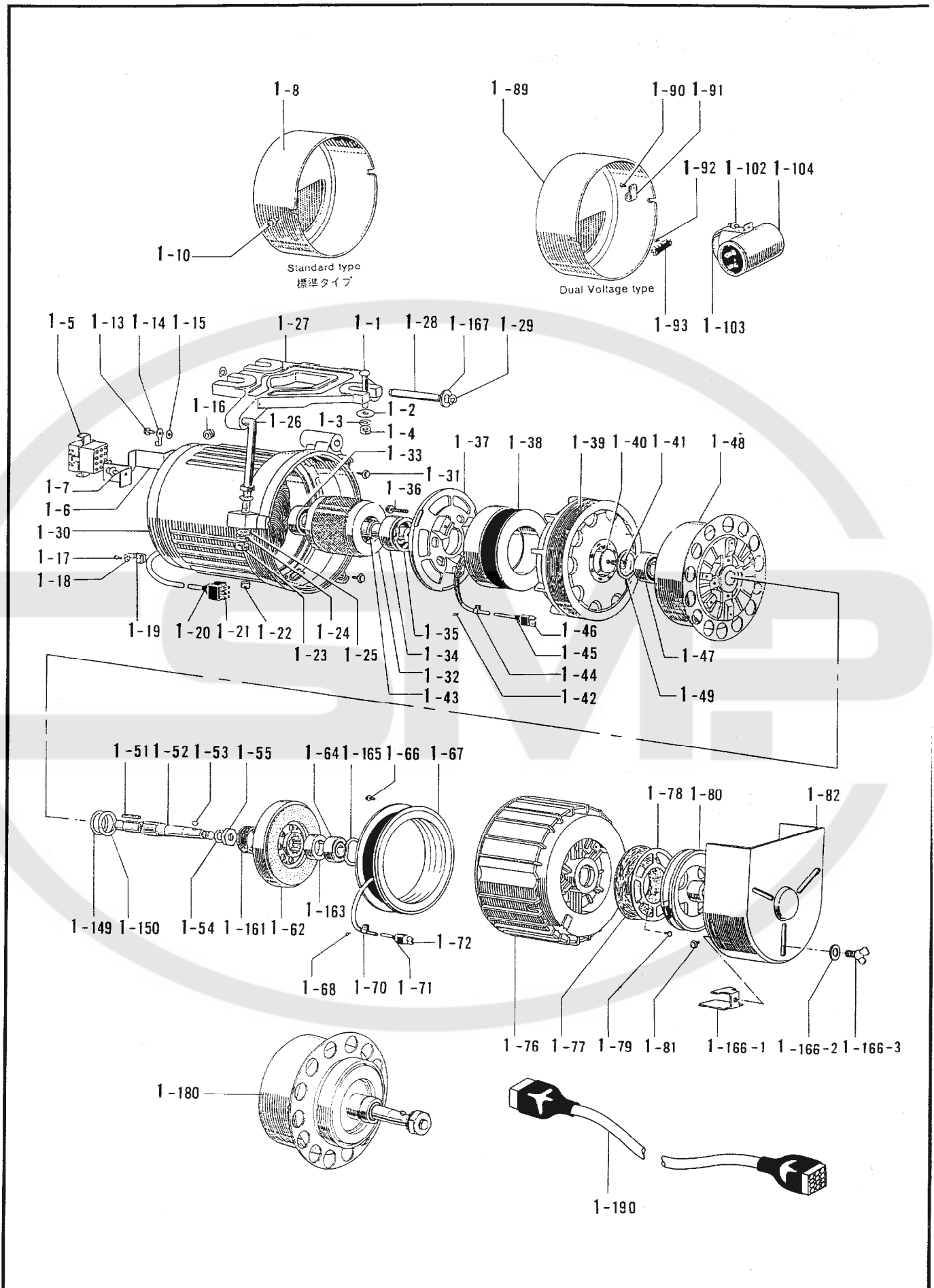

X2. モータ関係 / Motor mechanism / Motor / Mécanisme du moteur / Mecanismo del motor

REF.NO.	CODE	Q'TY	ヒンメイ	NAME OF PARTS	RM
1	※	1	モータユニット	MOTOR UNIT	
1-1	S35913001	3	トリツケボルト	MOUNTING BOLT	
1-2	S35914001	3	ザガネ	WASHER	
1-3	S35915001	3	バネザガネ8	WASHER, SPRING M8	
1-4	S35916001	3	ナットM8	NUT, M8	
1-5	※	1	ギャクテンブラグウケ	REVERSE ROTATION SOCKET	
1-6	※	1	トリツケイタ	ADAPTER	
1-7	※	2	SW-PW-Pナベネジ	SCREW, PAN (SW-PW-P)	
1-8	※	1	ハシカバー	END COVER	
1-10	S35919001	2	SW-PW-Pナベネジ	SCREW, PAN (SW-PW-P)	
1-13	S35921001	1	P-BSナベネジ	SCREW, PAN (P-BS)	
1-14	S35922001	2	アッチャクタンシ1.25F4	TERMINAL PIN (1.25F4)	
1-15	S35923001	1	ハツキザガネ	WASHER, TOOTH	
1-16	S35924001	1	ブッシュ6.3X4.5	BUSH 6.3X4.5	
1-17	S35925001	2	Pナベネジ	SCREW, PAN (P)	
1-18	S35926001	1	シメツケカナグ	FITTINGS	
1-19	※	1	ブッシュ	BUSH	
1-20	S35930001	1	ナイロンキャップ	NYLON CAP	
1-21	※	1	コネクタ3191	CONNECTOR 3191	
1-22	S35934001	1	ブッシュ6.3X4.5	BUSH 6.3X4.5	
1-23	S35935001	2	ナットM10	NUT, M10	
1-24	S35936001	1	バネザガネ10	WASHER, SPRING M10	
1-25	S35937001	2	ザガネ	WASHER	
1-26	S35938001	1	チョウセイボルト	ADJUSTING BOLT	
1-27	S35939001	1	ベース	BASE	
1-28	S35940001	1	ベースピン	BASE PIN	
1-29	S35941001	2	トメワE9	RETAINING RING, E9	
1-30	※	1	フレームステータクミ	FRAME STATOR ASSY	
1-31	S35943001	3	シメネジ	SCREW	
1-32	※	1	ロータ	ROTOR	
1-33	S35945001	1	ベアリング#6203	BALL BEARING, #6203	
1-34	S35946001	1	ベアリング#6204	BALL BEARING, #6204	
1-35	S35947001	1	プレロードスプリング	PRELOAD SPRING	
1-36	S35948001	3	SW-Pナベネジ	SCREW, PAN (SW-P)	
1-37	S35949001	1	ブラケット	BRACKET	
1-38	S35950001	1	クラッチコイルクミ	CLUTCH COIL ASSY	
1-39	※	1	ドライブメンバークミ	DRIVE MEMBER ASSY	
1-40	S35953001	1	ザガネ	WASHER	
1-41	S35954001	1	SW-Pナベネジ	SCREW, PAN (SW-P)	
1-42	S36334001	1	Pナベネジ	SCREW, PAN (P)	
1-43	S35955001	1	スペーサ	SPACER	
1-44	S35956001	1	ナイロンクリップ	NYLON CLIP	
1-45	S35957001	1	ナイロンキャップ	NYLON CAP	
1-46	S35958001	1	コネクタ3191	CONNECTOR 3191	
1-47	S35959001	1	ベアリング#6302	BALL BEARING, #6302	
1-48	S35960001	1	ドリブンメンバークミ	DRIVEN MEMBER ASSY	
1-49	S35961001	1	ワッシャ	WASHER	
1-51	S35962001	1	キー5X5X18	KEY 5X5X18	
1-52	S35963001	1	クラッチジク	CLUTCH SHAFT	
1-53	S35964001	1	ハンゲツキー4X13	WOODRUFF KEY 4X13	
1-54	S35936001	1	バネザガネ10	WASHER, SPRING M10	
1-55	S35965001	1	ナットM10X1	NUT, M10X1	
1-62	S35970001	1	カドウイタ	ARMATURE	
1-64	S35971001	1	ベアリング#6202	BALL BEARING, #6202	
1-66	S35972001	3	シメネジ	SCREW	
1-67	S35973001	1	コティコアクミ	FIXED CORE ASSY	
1-68	S35974001	1	タツブタイトネジM4	SCREW, TAPTITE M4	
1-70	S35975001	1	ナイロンクリップ	NYLON CLIP	
1-71	S35976001	1	ナイロンキャップ	NYLON CAP	
1-72	S35977001	1	コネクタ3191	CONNECTOR 3191	
1-76	S35978001	1	Pガワブラケット	LOAD SIDE BRACKET	

X2. モーター関係 / Motor mechanism / Motor / Mécanisme du moteur / Mecanismo del motor

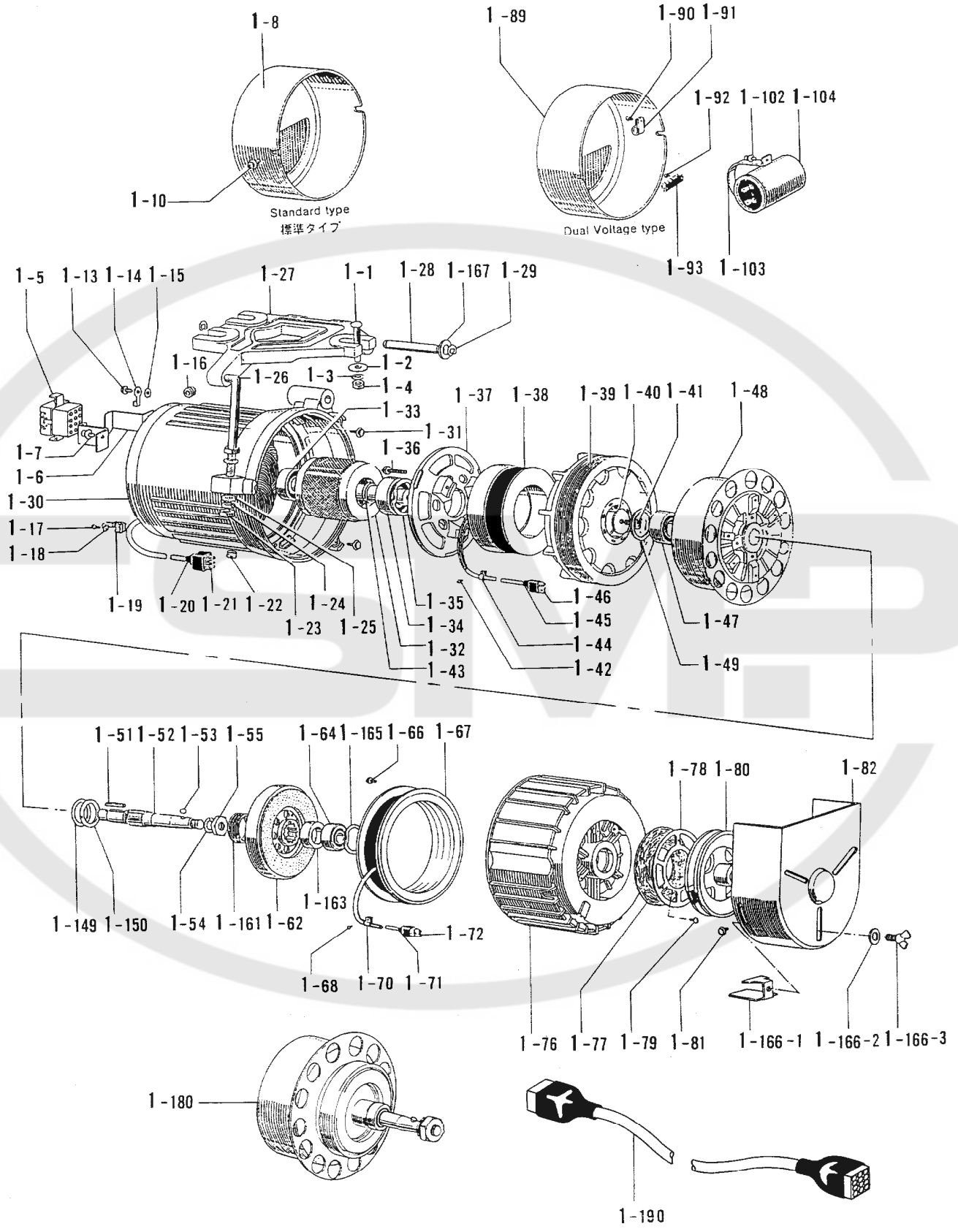

X2. モータ関係 / Motor mechanism / Motor / Mécanisme du moteur / Mecanismo del motor

REF.NO.	CODE	QTY	ヒンメイ	NAME OF PARTS	RM
1-77	S35979001	1	フィルタ	FILTER	
1-78	S35980001	1	オサエイタ	PRESSER PLATE	
1-79	S35974001	3	タツブタイトネジM4	SCREW, TAPTITE M4	
1-80	S35981001	1	プーリ	PULLEY	
1-81	S35982001	2	SW-PW-Pナベネジ	SCREW, PAN (SW-PW-P)	
1-82	S35983001	1	ベルトカバー	BELT COVER	
1-89	※	1	ハシカバー	END COVER	
1-90	S35985001	1	Pナベネジ	SCREW, PAN (P)	
1-91	S36336001	1	ナイロンクリップ	NYLON CLIP	
1-92	S35986001	2	SW-PW-Pナベネジ	SCREW, PAN (SW-PW-P)	
1-93	S35987001	1	タンシダイ	TERMINAL BLOCK	
1-102	S35919001	2	SW-PW-Pナベネジ	SCREW, PAN (SW-PW-P)	
1-103	S35989001	1	トリツケイタ	ADAPTER PLATE	
1-104	※	1	コンデンサ	CAPACITOR	
1-149	S36321001	1	ワッシャt=1.0	WASHER, T= 1.0	
1-150	S36322001	2	ワッシャt=0.25	WASHER, T= 0.25	
1-161	S36323001	1	ブレーキバネ	SPRING, BRAKE	
1-163	S36324001	1	キャップ	CAP	
1-165	S36325001	1	プレロードスプリング	PRELOAD SPRING	
1-166	S36326001	1	ベルトハズレボウシセット	BELT GUIDE ASSY	
1-166-1	S36328001	1	トリツケイタ	BELT GUIDE	
1-166-2	S36329001	1	ザガネ	WASHER	
1-166-3	S36330001	1	チョウボルト	BOLT	
1-167	S36327001	1	プレロードスプリング	PRELOAD SPRING	
1-180	S36332001	1	クラッチジククミ	CLUTCH SHAFT ASSY	
1-190	※	1	セツゾクデンセンクミ	CONNECTING WIRE ASSY	

138-980-650

参照 番号 Ref.No.	品名 Name of parts	国内用 / For domestic		輸出用 / For export					
		単相 / 1 phase	3相 / 3 phase	単相 / 1 phase			3相 / 3 phase		
		100V	200V	110V	200V-220V	230V-240V	220V	380V	415V
X2-1	モータユニット MOTOR UNIT	S36333001	S36337001	S36347001	S36350001	S36512001	S36341001	S36344001	S36346001
X2-1-5	ギャクテンプラグウケ REVERSE ROTATION SOCKET	S35917001	←	←	←	←	-----	-----	-----
X2-1-6	トリツケイタ ADAPTER	S35918001	←	←	←	←	-----	-----	-----
X2-1-7	SW-PW-Pナベネジ SCREW, PAN (SW-PW-P)	S35919001	←	←	←	←	-----	-----	-----
X2-1-8	ハシカバー END COVER	S35920001	←	←	←	←	-----	-----	-----
X2-1-19	ブッシュ BUSH	S35927001	←	←	S35928001	←	S35927001	←	←
X2-1-21	コネクタ3191 CONNECTOR 3191 (白)	S35931001	←	S35932001 (青)(-BU)	←	←	←	S35933001 (黒)(-BL)	←
X2-1-30	フレームステーダクミ FRAME STATOR ASSY	S35942001	S36338001	S36348001	S36511001	S36513001	S36342001	←	←
X2-1-32	ロータ ROTOR	S35944001	S36339001	S35944001	←	←	S36339001	←	←
X2-1-39	ドライブメンバークミ DRIVE MEMBER ASSY	S35951001	S35952001	S35951001	←	←	S35952001	←	←
X2-1-89	ハシカバー END COVER	-----	-----	-----	-----	-----	S35984001	←	←
X2-1-104	コンデンサ CAPACITOR	S35990001	-----	S35990001	←	←	-----	-----	-----
X2-1-190	セツゾクデンセンクミ CONNECTING WIRE ASSY	S36336001	←	S36349001	←	←	S36343001	←	←

Y. コントロールボックス関係 / Control box mechanism / Schaltkasten /
 Mécanisme du boîtier de contrôle / Mecanismo de la caja de controles

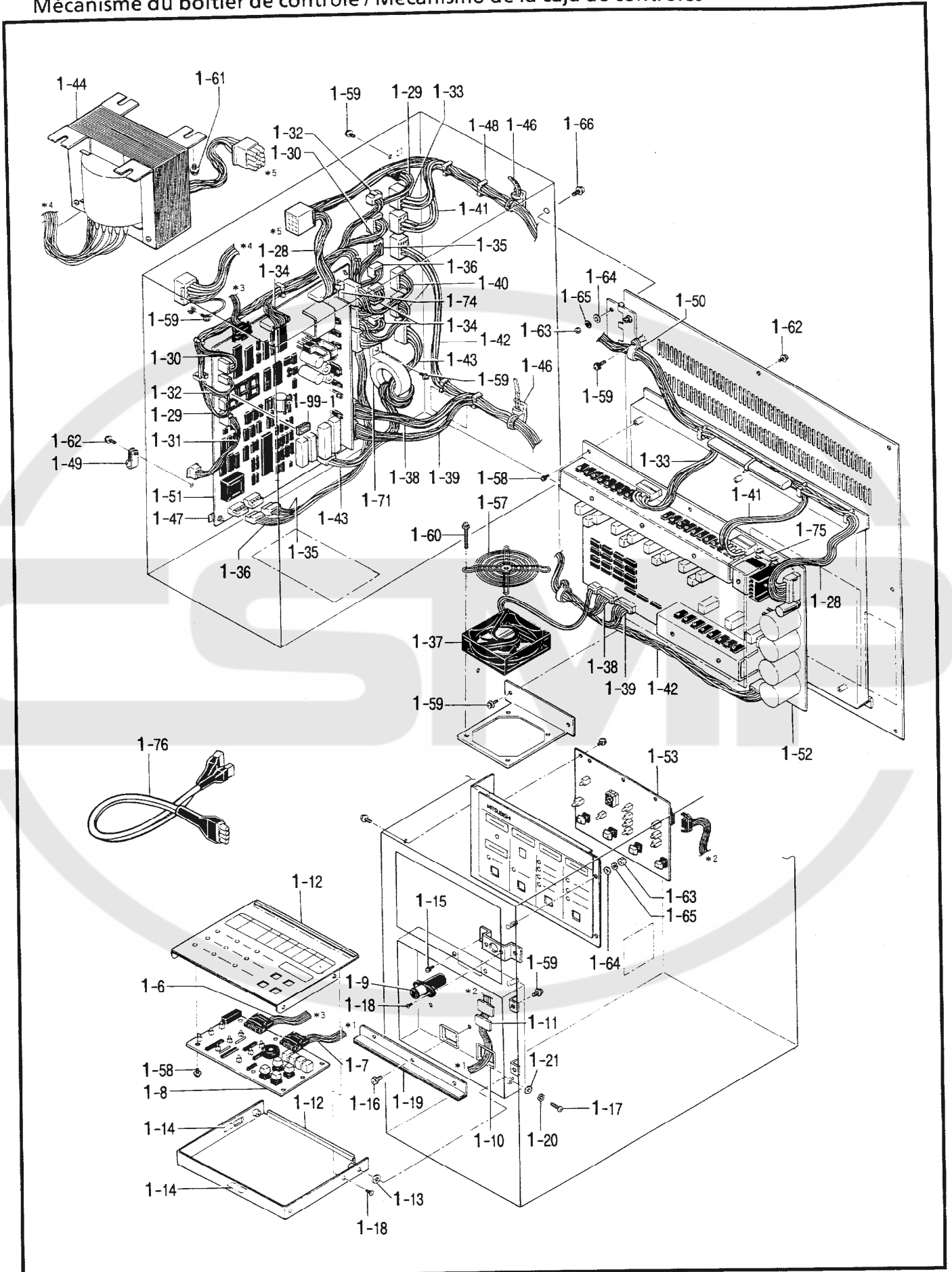

Y. コントロールボックス関係 / Control box mechanism / Schaltkasten /
 Mécanisme du boîtier de contrôle / Mecanismo de la caja de controles

REF.NO.	CODE	Q'TY	ヒンメイ	NAME OF PARTS	RM
1	S35484001	1	セイギョバンクミ	CONTROL CIRCUIT BOARD ASSY	
1-6	S35883001	1	セツゾクデンセンクミ	CONNECTING WIRE ASSY	
1-7	S35884001	1	セツゾクデンセンクミ	CONNECTING WIRE ASSY	
1-8	S35885001	1	プリントキバン	PRINT CIRCUIT BOARD	
1-9	S35888001	1	ワンタッチオープンキャッチ	ONE-TOUCH OPEN CATCH	
1-10	S35889001	2	スクウエアブッシュ	SQUARE BUSH	
1-11	S35890001	4	フラットケーブルクリップ	FLAT CABLE CLIP	
1-12	S35891001	2	エツジングブッシュ	EDGING BUSH	
1-13	S35892001	2	ネジヨウヌケドメワッシャー	STOPPER WASHER	
1-14	S35887001	1	ヒョウジメイバン	RATING LABEL	
1-15	S35895001	8	SW-PW-Pナベネジ	SCREW, PAN (SW-PW-P)	
1-16	S35896001	3	SW-PW-Pナベネジ	SCREW, PAN (SW-PW-P)	
1-17	S35897001	2	Pナベネジ	SCREW, PAN (P)	
1-18	S35898001	6	Pサラネジ	SCREW, FLAT (P)	
1-19	S35899001	1	ゴム	RUBBER	
1-20	S35866001	2	バネザガネ	WASHER, SPRING	
1-21	S35865001	2	ヒラザガネ	WASHER, PLAIN	
1-28	S35491001	1	セツゾクデンセンクミ	CONNECTING WIRE ASSY	
1-29	S35492001	1	セツゾクデンセンクミ	CONNECTING WIRE ASSY	
1-30	S35493001	1	セツゾクデンセンクミ	CONNECTING WIRE ASSY	
1-31	S35494001	1	セツゾクデンセンクミ	CONNECTING WIRE ASSY	
1-32	S35495001	1	セツゾクデンセンクミ	CONNECTING WIRE ASSY	
1-33	S35496001	1	セツゾクデンセンクミ	CONNECTING WIRE ASSY	
1-34	S35497001	1	セツゾクデンセンクミ	CONNECTING WIRE ASSY	
1-35	S35498001	1	セツゾクデンセンクミ	CONNECTING WIRE ASSY	
1-36	S35499001	1	セツゾクデンセンクミ	CONNECTING WIRE ASSY	
1-37	S35500001	1	セツゾクデンセンクミ	CONNECTING WIRE ASSY	
1-38	S35501001	1	セツゾクデンセンクミ	CONNECTING WIRE ASSY	
1-39	S35502001	1	セツゾクデンセンクミ	CONNECTING WIRE ASSY	
1-40	S35503001	1	セツゾクデンセンクミ	CONNECTING WIRE ASSY	
1-41	S35504001	1	セツゾクデンセンクミ	CONNECTING WIRE ASSY	
1-42	S35505001	1	セツゾクデンセンクミ	CONNECTING WIRE ASSY	
1-43	S35506001	1	セツゾクデンセンクミ	CONNECTING WIRE ASSY	
1-44	S35507001	1	セツゾクデンセンクミ	CONNECTING WIRE ASSY	
1-46	S35847001	2	ULクランプ	(UL) CORD CLAMP	
1-47	S35848001	10	ロッキングサポート	LOCKING SUPPORT	
1-48	S35849001	18	ワイヤサドル	WIRE SADDLE	
1-49	S35850001	1	ナイロンクリップ	NYLON CLIP	
1-50	S35851001	2	ナイロンクリップ	NYLON CLIP	
1-51	S35852001	1	プリントキバン	PRINT CIRCUIT BOARD	
1-52	S35853001	1	プリントキバン	PRINT CIRCUIT BOARD	
1-53	S35854001	1	プリントキバン	PRINT CIRCUIT BOARD	
1-57	S35859001	1	フィンガーガード	FINGER GUARD	
1-58	S35895001	13	SW-PW-Pナベネジ	SCREW, PAN (SW-PW-P)	
1-59	S35860001	10	SW-PW-Pナベネジ	SCREW, PAN (SW-PW-P)	
1-60	S35861001	4	SW-PW-Pナベネジ	SCREW, PAN (SW-PW-P)	
1-61	S35862001	4	SW-PW-Pナベネジ	SCREW, PAN (SW-PW-P)	
1-62	S35868001	10	SW-PW-SUSナベネジ	SCREW, PAN (SW-PW-SUS)	
1-63	S35864001	6	ナット	NUT	
1-64	S35876001	6	ヒラザガネ	WASHER, PLAIN	
1-65	S35877001	6	バネザガネ	WASHER, SPRING	
1-66	S35868001	4	SW-PW-SUSナベネジ	SCREW, PAN (SW-PW-SUS)	
1-71	S35845001	1	フィルター	FILTER	
1-74	S35893001	1	ヒューズ	FUSE	
1-75	S35894001	1	ヒューズ	FUSE	
1-76	S36884001	1	セツゾクデンセンクミ	CONNECTING WIRE ASSY	
1-99	S37618000	1	PROM980クミ	PROM980 ASSY	
1-99-1	S37616000	1	PROM980-E	PROM980-E	
1-99-1	S37617000	1	PROM980-F	PROM980-F	

Z. 付属品関係 / Accessories / Zubehör / Accessoires / Accesorios

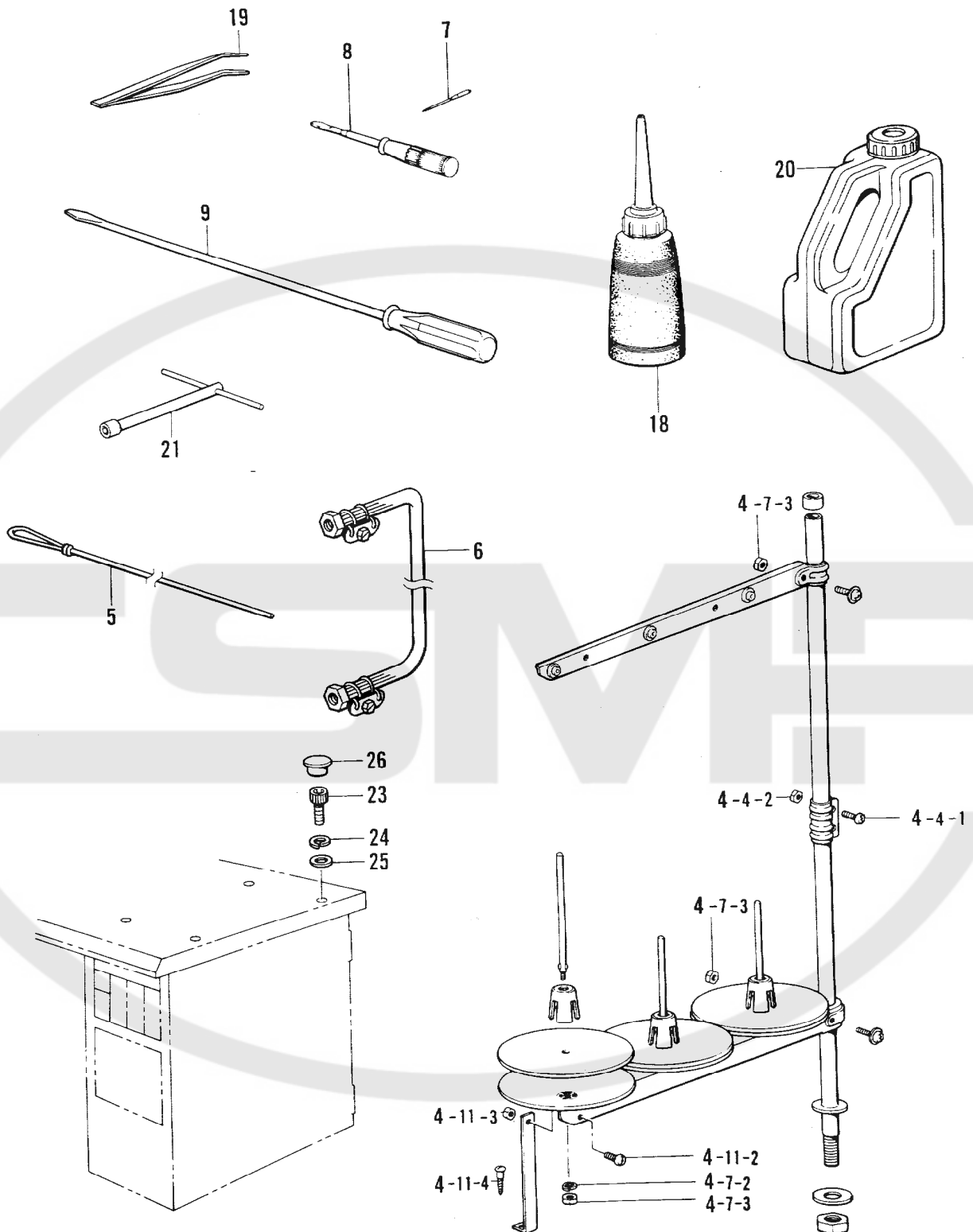

- ◎ 付属品の明細は変更することがあります。
- ◎ The details of included accessories are subject to change.
- ◎ Änderungen in der Aufstellung der Mitgelieferten Zubehöre sind vorbehalten.
- ◎ Les détails des accessoires inclus sont sujets à des changements.
- ◎ Los detalles de los accesorios incluidos pueden variar.

Z. 付属品関係 / Accessories / Zubehör / Accessoires / Accesorios

REF.NO.	CODE	Q'TY	ヒンメイ	NAME OF PARTS	RM
4	S02766009	1	イトタテダイクミ3D	COTTON STAND ASSY (3D)	
4-4-1	062501406	2	ナベコ5X14	SCREW, PAN M5X14	
4-4-2	021500106	2	1シユナツト5	NUT, 1 M5	
4-7-2	028050246	3	バネザガネ2-5	WASHER, SPRING 2-5	
4-7-3	021500106	5	1シユナツト5	NUT, 1 M5	
4-11-2	062501006	1	ナベコ5X10	SCREW, PAN M5X10	
4-11-3	021500106	1	1シユナツト5	NUT, 1 M5	
4-11-4	031452206	1	マルモク45X22	WOOD SCREW, ROUND M4.5X22	
5	S34915000	1	イトトオシ	THREADER	
6	149796001	1	ゴムホースカナグツキ	AIR TUBE WITH CONNECTOR	
8	118837001	1	ネジマワシ3.4X70	SCREW DRIVER 3.4X70	
9	101572101	1	ネジマワシ5.5X190	SCREW DRIVER 5.5X190	
18	114483002	1	ポリオイラークミ	OILER ASSY	
19	117466000	1	ピンセット	PINCETTE	
20	154702101	1	オイルタンク	OIL TANK	
21	140342001	1	ソケットレンチクミ	SOCKET WRENCH ASSY	
<-00><上糸切り用 / FOR UPPER THREAD TRIMMER>					
7	S35133016	10	ミシンハリDOX558 (#16)	NEEDLE DOX558 (#16)	
<-01><上下糸切り用 / FOR UPPER AND LOWER THREAD TRIMMER>					
7	S35133014	10	ミシンハリDOX558 (#14)	NEEDLE DOX558 (#14)	
<-02><ジーンズ仕様/JEANS SPECIFICATION>					
7	S35133118	10	ミシンハリDOX558 (#18)	NEEDLE DOX558 (#18)	
<輸出用 / FOR EXPORT>					
23	018084032	4	-----	BOLT, SOCKET M8X40	
24	028080242	4	-----	WASHER, SPRING 2-8	
25	025080232	4	-----	WASHER, PLAIN M 8	
26	159150009	4	-----	OIL CAP	

a. 付屬裝置關係 / Attachment set / Anbausatz / Jeu d'accessoires / Juego de fijación

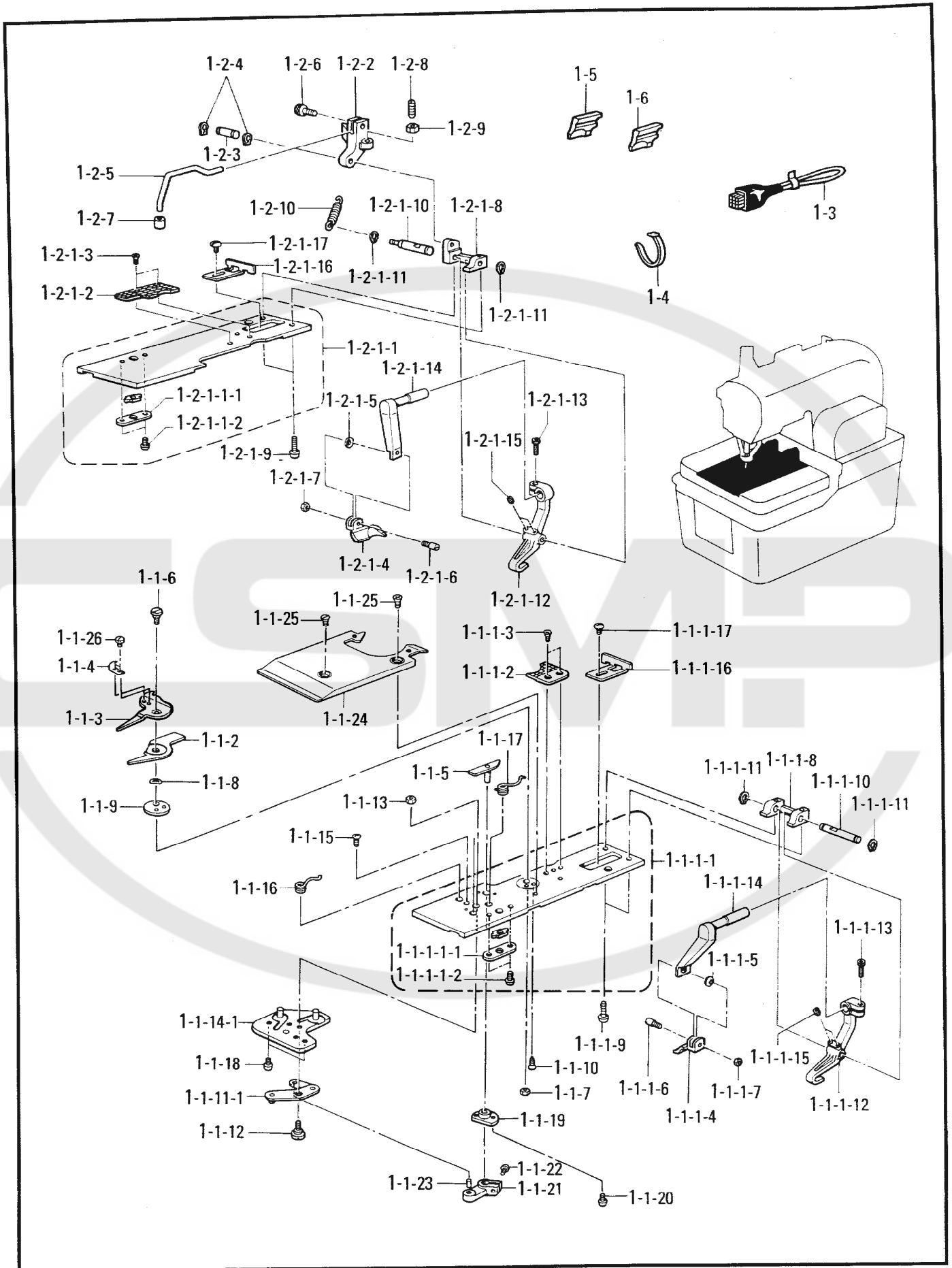

118-980-940

a. 付属装置関係 / Attachment set / Anbausatz / Jeu d'accessoires / Juego de fijación

REF.NO.	CODE	Q'TY	ヒンメイ	NAME OF PARTS	RM
<L1 14 - 18mm>					
1	S38572001	1	クミカエブヒンセット(L1)	EXCHANGE PARTS SET (L1)	
1-1	S38576101	1	L1プレートRクミ	(L1) PLATE (R) ASSY	
1-1-1	S37756001	1	オサエプレートJR1ソウクミ	CLOTH PRESSER PLATE (J)(R1) SET	
1-1-1-2	S37644001	1	ハリイタL1R	NEEDLE PLATE (L1)(R)	
1-1-1-4	S37754001	1	ヌノオサエR-JL1	CLOTH PRESSER (R-J)(L1)	
1-1-2	S37673001	1	イドウハL1R	MOVABLE KNIFE (L1)(R)	
1-1-3	S37669001	1	イドウハL1L	MOVABLE KNIFE (L1)(L)	
1-1-4	S37665000	1	イトサバキL1	THREAD HANDLER L1	
1-1-5	S37661001	1	イドウハクドウカムL1	MOVABLE KNIFE DRIVING CAM (L1)	
<L2 18 - 22mm>					
1	S38573001	1	クミカエブヒンセット(L2)	EXCHANGE PARTS SET (L2)	
1-1	S38578101	1	L2プレートRクミ	(L2) PLATE (R) ASSY	
1-1-1	S37727001	1	オサエプレートJR2ソウクミ	CLOTH PRESSER PLATE (J)(R2) SET	
1-1-1-2	S37646001	1	ハリイタL2R	NEEDLE PLATE (L2)(R)	
1-1-1-4	S37690001	1	ヌノオサエR-JL2	CLOTH PRESSER (R-J)(L2)	
1-1-2	S37674001	1	イドウハL2R	MOVABLE KNIFE (L2)(R)	
1-1-3	S37670001	1	イドウハL2L	MOVABLE KNIFE (L2)(L)	
1-1-4	S37666000	1	イトサバキL2	THREAD HANDLER L2	
1-1-5	S37662001	1	イドウハクドウカムL2	MOVABLE KNIFE DRIVING CAM (L2)	
<L3 22 - 26mm>					
1	S38574001	1	クミカエブヒンセット(L3)	EXCHANGE PARTS SET (L3)	
1-1	S38580101	1	L3プレートRクミ	(L3) PLATE (R) ASSY	
1-1-1	S37733001	1	オサエプレートJR3ソウクミ	CLOTH PRESSER PLATE (J)(R3) SET	
1-1-1-1	S37648001	1	ハリイタL3R	NEEDLE PLATE (L3)(R)	
1-1-1-2	S37692001	1	ヌノオサエR-JL3	CLOTH PRESSER (R-J)(L3)	
1-1-2	S37675001	1	イドウハL3R	MOVABLE KNIFE (L3)(R)	
1-1-3	S37671001	1	イドウハL3L	MOVABLE KNIFE (L3)(L)	
1-1-4	S37667000	1	イトサバキL3	THREAD HANDLER L3	
1-1-5	S37663001	1	イドウハクドウカムL3	MOVABLE KNIFE DRIVING CAM (L3)	
<L4 26 - 30mm>					
1	S38575001	1	クミカエブヒンセット(L4)	EXCHANGE PARTS SET (L4)	
1-1	S38582101	1	L4プレートRクミ	(L4) PLATE (R) ASSY	
1-1-1	S37757001	1	オサエプレートJR4ソウクミ	CLOTH PRESSER PLATE (J)(R4) SET	
1-1-1-1	S37650001	1	ハリイタL4R	NEEDLE PLATE (L4)(R)	
1-1-1-2	S37758001	1	ヌノオサエR-JL4	CLOTH PRESSER (R-J)(L4)	
1-1-2	S37676001	1	イドウハL4R	MOVABLE KNIFE (L4)(R)	
1-1-3	S37672001	1	イドウハL4L	MOVABLE KNIFE (L4)(L)	
1-1-4	S37668000	1	イトサバキL4	THREAD HANDLER L4	
1-1-5	S37664001	1	イドウハクドウカムL4	MOVABLE KNIFE DRIVING CAM (L4)	
1-1-1-1	S37729001	1	オサエプレートJRクミ	CLOTH PRESSER PLATE (J)(R) ASSY	
1-1-1-1-1	S35315001	1	ヒラキカクコマ	OPENING SLIDE BLOCK	
1-1-1-1-2	060020416	2	バインドM2X4	SCREW, BIND M2X4	
1-1-1-3	S06696004	2	サラコネジ3X6	SCREW, FLAT M3X6	
1-1-1-5	S35236000	1	マゲザガネ3.2	BENDING WASHER, M3.2	
1-1-1-6	S35235001	1	クランプササエピン	CLAMP SUPPORT PIN	
1-1-1-7	021300302	1	3シユナツト3	NUT, 3 M3	
1-1-1-8	S35238001	1	クランプジクウケ	CLAMP SHAFT HOLDER	
1-1-1-9	062401016	2	ナベコ4X10	SCREW, PAN M4X10	
1-1-1-10	S35237001	1	クランプシテンジク	CLAMP FULCRUM SHAFT	
1-1-1-11	048050142	2	トメワジクヨウC5	RETAINING RING, C5	
1-1-1-12	S35234201	1	クランプレバーR	CLAMP LEVER (R)	
1-1-1-13	018501236	1	アナボルト5X12	BOLT, SOCKET M5X12	
1-1-1-14	S37695001	1	クランプアームR-J	CLAMP ARM (R-J)	
1-1-1-15	014400532	2	アナコボミ4X5	SET SCREW, SOCKET (CP) M4X5	
1-1-1-16	S35347000	1	ヌノガイドR	CLOTH GUIDE (R)	
1-1-1-17	060350616	1	バインド3.5X6	SCREW, BIND M3.5X6	
1-1-6	S37660001	1	ダンネジM4	SHOULDER SCREW, M4	
1-1-7	021400202	1	2シユナツト4	NUT, 2 M4	
1-1-8	S37654000	1	ナミザガネ	WASHER, WAVE	
1-1-9	S37655001	1	メスササエザガネ	KNIFE SUPPORT WASHER	
1-1-10	141542001	2	サラネジ3.18	SCREW, FLAT M3.18	
1-1-11-1	S37656001	1	イトキリリンクレバーJクミ	THREAD TRIMMER LINK LEVER (J) ASSY	
1-1-12	S34881001	1	ダンネジM4	SHOULDER SCREW, M4	
1-1-13	021400202	1	2シユナツト4	NUT, 2 M4	
1-1-14-1	S37820001	1	リンクシテンプレートクミ	LINK FULCRUM PLATE ASSY	
1-1-15	062400616	2	ナベコM4X6	SCREW, PAN M4X6	
1-1-16	S37652001	1	モドシバネL	SPRING (L)	
1-1-17	S37653001	1	モドシバネR	SPRING (R)	
1-1-18	062300416	2	ナベコM3X4	SCREW, PAN M3X4	
1-1-19	S34906000	1	イトキリウデメタル	THREAD TRIMMER ARM BUSH	
1-1-20	062260612	2	ナベコ2.6X6	SCREW, PAN M2.6X6	
1-1-21	S37659001	1	イトキリレバーウデB	THREAD CUTTER LEVER ARM (B)	
1-1-22	S21716001	1	ボタンヘッドネジ4X10	SCREW 4X10	
1-1-23	S37858000	1	ニードルピン4X8	NEEDLE PIN 4X8	
1-1-24	S37700001	1	オサエプレートU	PRESSER PLATE (U)	
1-1-25	004401003	2	+サラネジ4X10	SCREW, FLAT M4X10	
1-1-26	153787001	2	シメネジ2.38	SCREW, M2.38	

a. 付属装置関係 / Attachment set / Anbausatz / Jeu d'accessoires / Juego de fijación

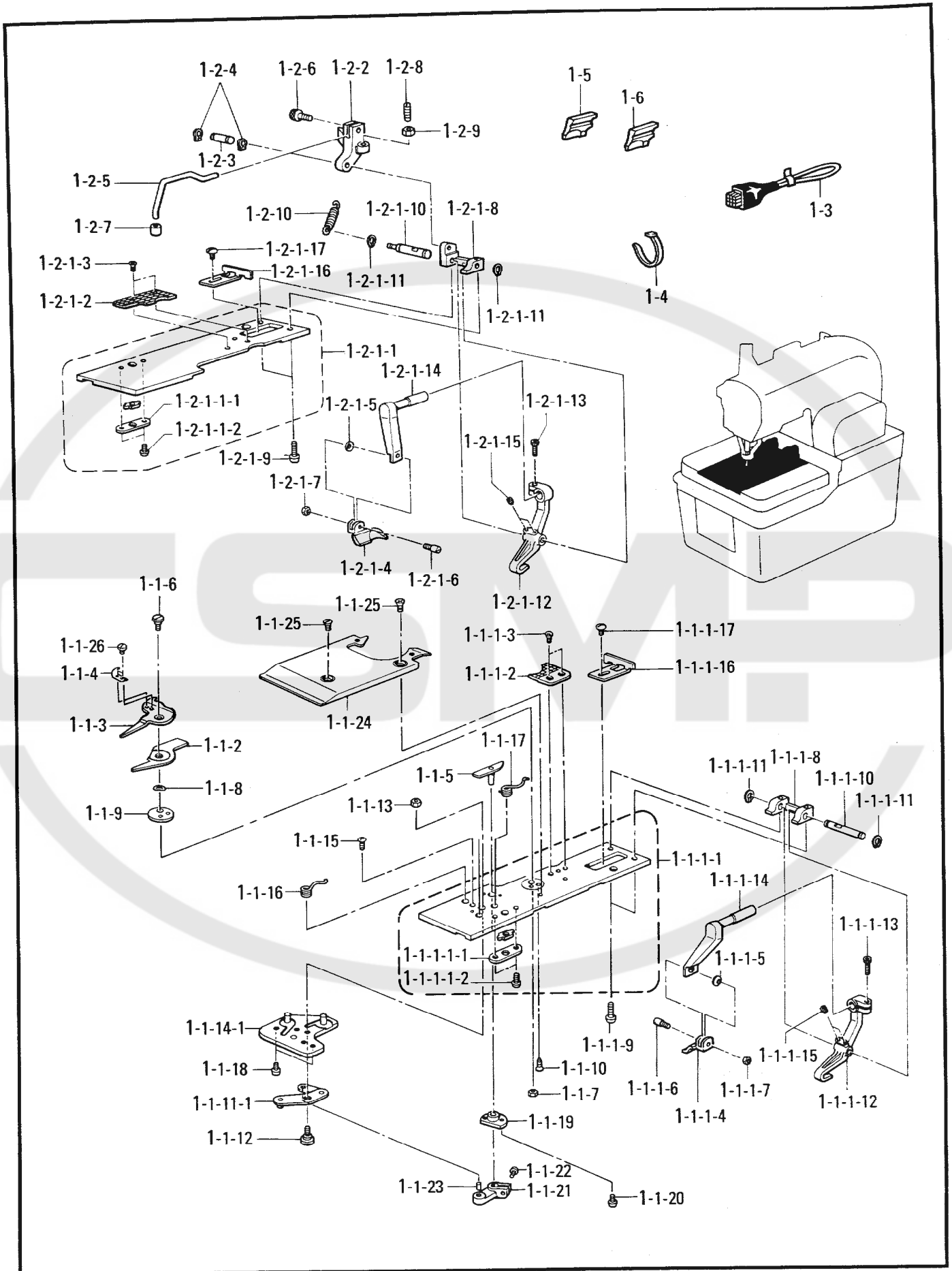

a. 付属装置関係 / Attachment set / Anbausatz / Jeu d'accessoires / Juego de fijación

REF.NO.	CODE	Q'TY	ヒンメイ	NAME OF PARTS	RM
<L1 14-18mm>					
1-2	S38577101	1	L1プレートLクミ	(L1) PLATE (L) ASSY	
1-2-1	S37731001	1	オサエプレートJL1ソウクミ	CLOTH PRESSER PLATE (J)(L1) SET	
1-2-1-2	S37643001	1	ハリイタL1L	NEEDLE PLATE (L1)(L)	
1-2-1-4	S37755001	1	ヌノオサエL-JL1	CLOTH PRESSER (L-J)(L1)	
1-3	S37869000	1	シヨウハーネスL1	HARNESS (L1)	
1-5	S37702001	1	ハンマーS12	HAMMER (S12)	
1-6	S37704001	1	ハンマーS16	HAMMER (S16)	
<L2 18-22mm>					
1-2	S38579101	1	L2プレートLクミ	(L2) PLATE (L) ASSY	
1-2-1	S37728001	1	オサエプレートJL2ソウクミ	CLOTH PRESSER PLATE (J)(L2) SET	
1-2-1-2	S37645001	1	ハリイタL2L	NEEDLE PLATE (L2)(L)	
1-2-1-4	S37689001	1	ヌノオサエL-JL2	CLOTH PRESSER (L-J)(L2)	
1-3	S37871000	1	シヨウハーネスL2	HARNESS (L2)	
1-5	S37704001	1	ハンマーS16	HAMMER (S16)	
1-6	S37706001	1	ハンマーS20	HAMMER (S20)	
<L3 22-26mm>					
1-2	S38581101	1	L3プレートLクミ	(L3) PLATE (L) ASSY	
1-2-1	S37735001	1	オサエプレートJL3ソウクミ	CLOTH PRESSER PLATE (J)(L3) SET	
1-2-1-2	S37647001	1	ハリイタL3L	NEEDLE PLATE (L3)(L)	
1-2-1-4	S37691001	1	ヌノオサエL-JL3	CLOTH PRESSER (L-J)(L3)	
1-3	S37872000	1	シヨウハーネスL3	HARNESS (L3)	
1-5	S37706001	1	ハンマーS20	HAMMER (S20)	
1-6	S37708001	1	ハンマーS24	HAMMER (S24)	
<L4 26-30mm>					
1-2	S38583101	1	L4プレートLクミ	(L4) PLATE (L) ASSY	
1-2-1	S37732001	1	オサエプレートJL4ソウクミ	CLOTH PRESSER PLATE (J)(L4) SET	
1-2-1-2	S37649001	1	ハリイタL4L	NEEDLE PLATE (L4)(L)	
1-2-1-4	S37759001	1	ヌノオサエL-JL4	CLOTH PRESSER (L-J)(L4)	
1-3	S37873000	1	シヨウハーネスL4	HARNESS (L4)	
1-5	S37708001	1	ハンマーS24	HAMMER (S24)	
1-6	S37709001	1	ハンマーS26	HAMMER (S26)	
1-2-1-1	S37730001	1	オサエプレートJLクミ	CLOTH PRESSER PLATE (J)(L) ASSY	
1-2-1-1-1	S35316001	1	カクコマササエイタ	SLIDE BLOCK SUPPORT PLATE	
1-2-1-1-2	060020416	2	バインドM2X4	SCREW, BIND M2X4	
1-2-1-3	S06696004	2	サラコネジ3X6	SCREW, FLAT M3X6	
1-2-1-5	S35236000	1	マゲザガネ3.2	BENDING WASHER, M3.2	
1-2-1-6	S35235001	1	クランプササエピン	CLAMP SUPPORT PIN	
1-2-1-7	021300302	1	3シユナツト3	NUT, 3 M3	
1-2-1-8	S37712001	1	クランプジクウケ	CLAMP SHAFT HOLDER	
1-2-1-9	062401016	2	ナベコ4X10	SCREW, PAN M4X10	
1-2-1-10	S37711001	1	クランプシテンジク	CLAMP FULCRUM SHAFT	
1-2-1-11	048050142	2	トメワジクヨウC5	RETAINING RING, C5	
1-2-1-12	S35233201	1	クランプレバーL	CLAMP LEVER (L)	
1-2-1-13	018501236	1	アナボルト5X12	BOLT, SOCKET M5X12	
1-2-1-14	S37694001	1	クランプアームL-J	CLAMP ARM (L-J)	
1-2-1-15	014400532	2	アナクボミ4X5	SET SCREW, SOCKET (CP) M4X5	
1-2-1-16	S35348000	1	ヌノガイドL	CLOTH GUIDE (L)	
1-2-1-17	060350616	1	バインド3.5X6	SCREW, BIND M3.5X6	
1-2-2	S37714001	1	ホジヨオサエシテンダイ	SUB PRESSER FULCRUM BRACKET	
1-2-3	S37713001	1	ホジヨオサエシテンジク	SUB PRESSER FULCRUM SHAFT	
1-2-4	048050142	2	トメワジクヨウC5	RETAINING RING, C5	
1-2-5	S37718000	1	ホジヨオサエウデ	SUB PRESSER ARM	
1-2-6	018401032	1	アナボルト4X10	BOLT 4X10	
1-2-7	S05356000	1	ボタンオサエA	BUTTON PRESSER (A)	
1-2-8	S08808001	1	ストツブネジ	STOPPER SCREW	
1-2-9	021660102	1	ナツト1シユ3.18	NUT, 1 SM3.18	
1-2-10	S37753001	1	ホジヨオサエモドシバネ	SUB PRESSER SPRING	
1-4	S04557000	1	バンタイPLTIM	BAND PLTIM	

118-980-940

b. 付属装置関係 / Attachment set / Anbausatz / Jeu d'accessoires / Juego de fijación

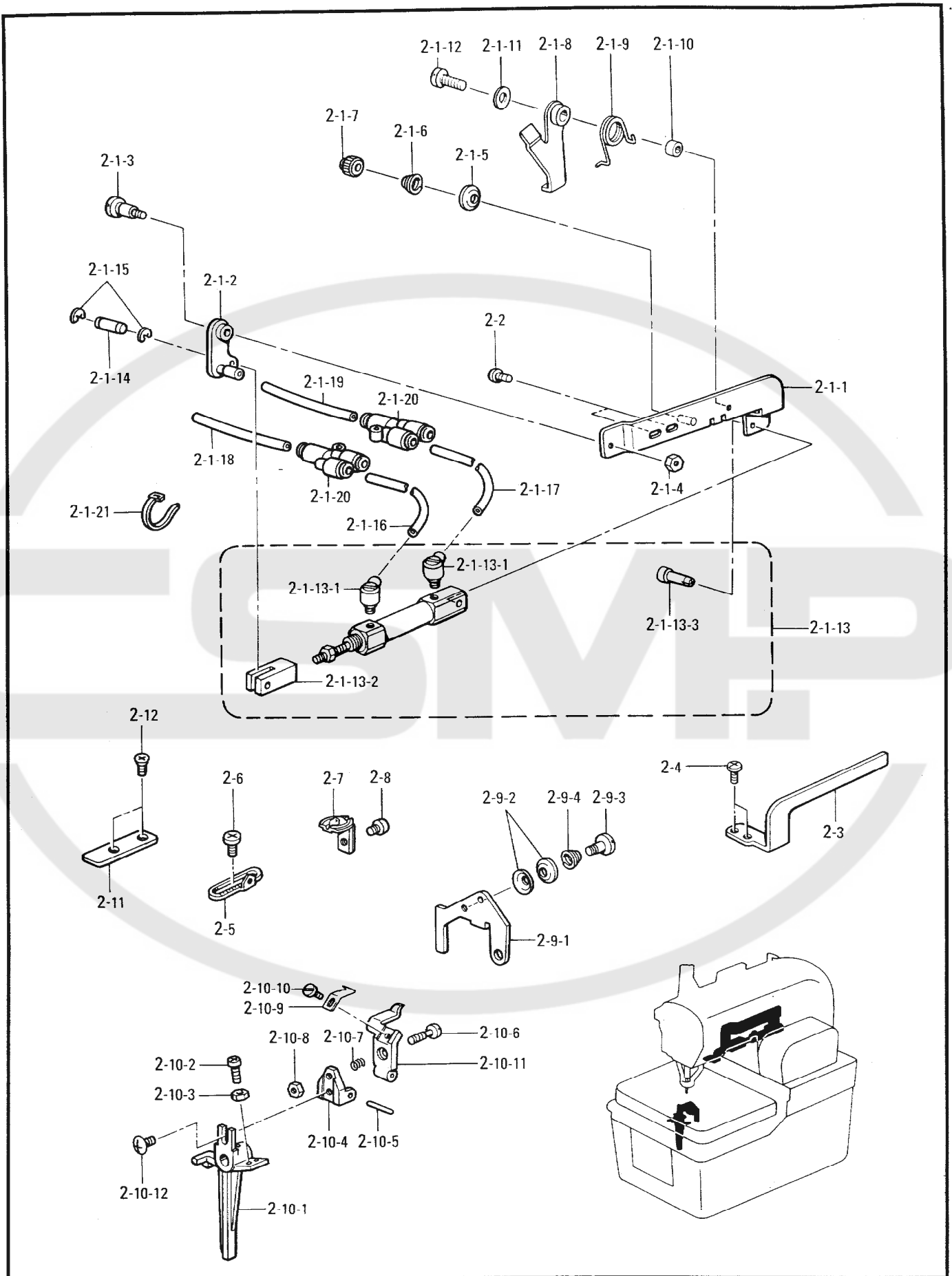

118-980-940

b. 付属装置関係 / Attachment set / Anbausatz / Jeu d'accessoires / Juego de fijación

REF.NO.	CODE	Q'TY	ヒンメイ	NAME OF PARTS	RM
2	S38584001	1	クミカエブヒンクミ(-2)	EXCHANGE PARTS ASSY (-2)	
2-1	S38585001	1	シリンダササエクミ	SYLINDER SUPPORT ASSY	
2-1-1	S37744001	1	Fオサエシリンダササエクミ	SUB PRESSER SYLINDER SUPPORT ASSY	
2-1-2	S37717001	1	ホジヨオサエリンククミ	SUB PRESSER LINK ASSY	
2-1-3	S34922001	1	ダンネジM4	SHOULDER SCREW, M4	
2-1-4	021400202	1	2シユナツト4	NUT, 2 M4	
2-1-5	144504001	1	イトアンナイサラ	THREAD GUIDE DISC	
2-1-6	154562001	1	プレテンションバネB	SPRING, PRE-TENSION (B)	
2-1-7	155510001	1	イトチヨウシナツト	TENSION NUT	
2-1-8	S37745001	1	シンイトユルメイタ	GIMP THREAD RELEASE PLATE	
2-1-9	S37749001	1	シンイトユルメイタバネ	GIMP THREAD RELEASE PLATE SPRING	
2-1-10	147236001	1	メストリツケウデコロ	KNIFE SET ARM ROLLER	
2-1-11	025040232	1	ヒラザガネチユウ4	WASHER, PLAIN M 4	
2-1-12	062401212	1	ナベコ4X12	SCREW, PAN M4X12	
2-1-13	S37737001	1	シリンダ10X15Jクミ	SYLINDER	
2-1-13-1	S12150000	2	ホースエルボM-5HL-4	TUBE ELBOW (M-5HL-4)	
2-1-13-2	S35351001	1	シリンダロッド	CYLINDER ROD	
2-1-13-3	S37866000	1	クレビスピン	CLEVIS PIN	
2-1-14	S35305001	1	シリンダロッドピン	CYLINDER ROD PIN	
2-1-15	048030342	2	トメワE3	RETAINING RING, E3	
2-1-16	S37738000	1	エア-ホース4X2.5-20	AIR TUBE 4X2.5-20 (L = 1350)	
2-1-17	S37739000	1	エア-ホース4X2.5-21	AIR TUBE 4X2.5-21 (L = 1400)	
2-1-18	S37863000	1	エア-ホース4X2.5-3J	AIR TUBE 4X2.5-21 (L = 100)	
2-1-19	S37864000	1	エア-ホース4X2.5-4J	AIR TUBE 4X2.5-21 (L = 100)	
2-1-20	S12104000	2	ユニオンワイ4	UNION-Y 4	
2-1-21	S04557000	1	バンタイPLTIM	BAND PLTIM	
2-2	062400812	2	ナベコ4X8	SCREW, PAN M4X8	
2-3	S37750001	1	シンイトトリアンナイJ	GIMP THREAD TAKE-UP GUIDE (J)	
2-4	062400812	2	ナベコ4X8	SCREW, PAN M4X8	
2-5	S37697001	1	シンイトアンナイJ	GIMP THREAD GUIDE (J)	
2-6	062400812	1	ナベコ4X8	SCREW, PAN M4X8	
2-7	S37752001	1	スロートプレート1.8-J	THROAT PLATE 1.8(J)	
2-8	S35326001	1	シメネジM3.5	SCREW, M3.5	
2-9	S39109001	1	シンイトアンナイC-Jクミ	GIMP GUIDE (C-J) ASSY	
2-9-1	S37696001	1	シンイトアンナイC-J	GIMP GUIDE (C-J)	
2-9-2	S35120001	2	ハライトアンナイサラ	THREAD GUIDE DISC	
2-9-3	S35119001	1	ハライトダンネジ3.18	STUD SCREW, M3.18	
2-9-4	S35118001	1	ハライトチヨウシバネ	TENSION SPRING	
2-10	S39108001	1	レバードダイBクミ	LEVER BRACKET (B) ASSY	
2-10-1	S37726001	1	イトキリレバードダイB	THREAD TRIMMER LEVER BRACKET (B)	
2-10-2	062301016	1	ナベコM3X10	SCREW, PAN M3X10	
2-10-3	021300302	1	3シユナツト3	NUT, 3M3	
2-10-4	S37721001	1	シタイトオサエダイ	LOWER THREAD PRESSER BRACKET	
2-10-5	148407001	1	ヨコアンナイミゾピンL	DOWEL PIN (L)	
2-10-6	S37724001	1	シメネジ2.38	SCREW, M2.38	
2-10-7	S37725001	1	シタイトオサエバネ	LOWER THREAD PRESSER SPRING	
2-10-8	021630102	1	ナツト1シユ2.	NUT, 1 M2	
2-10-9	S37723001	1	ウワイドウハB	UPPER MOVABLE KNIFE (B)	
2-10-10	105288001	1	シメネジ2.38	SCREW, M2.38	
2-10-11	S37720001	1	シタイトオサエ	LOWER THREAD PRESSER	
2-10-12	060350616	1	バインド3.5X6	SCREW, BIND M3.5X6	
2-11	S37693001	1	プレートガイドイタC	PLATE GUIDE (C)	
2-12	S06696004	2	サラコネジ3X6	SCREW, FLAT M3X6	

c. 付屬裝置關係 / Attachment set / Anbausatz / Jeu d'accessoires / Juego de fijación

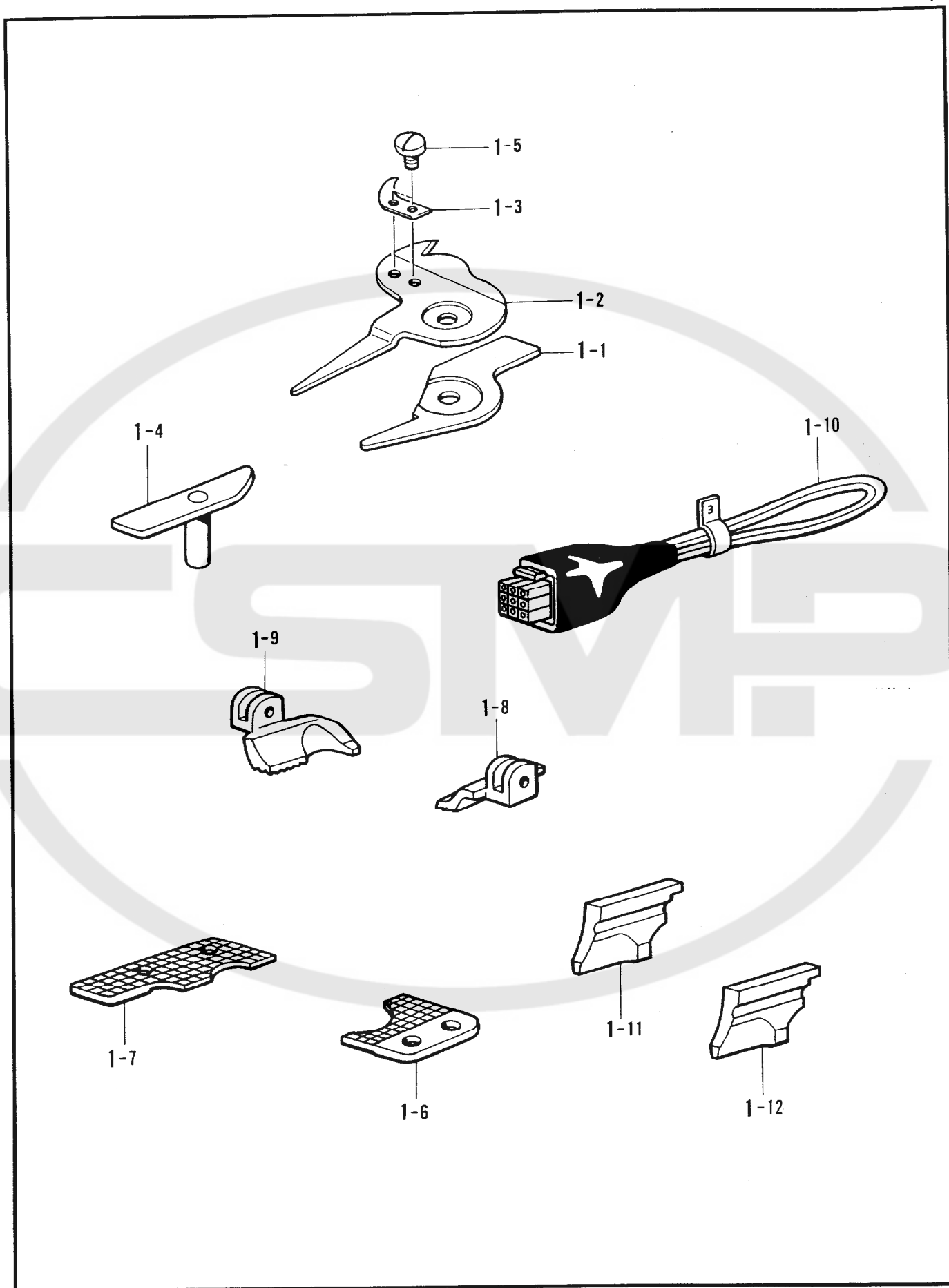

118-980-940



c. 付属装置関係 / Attachment set / Anbausatz / Jeu d'accessoires / Juego de fijación

REF.NO.	CODE	Q'TY	ヒンメイ	NAME OF PARTS	RM
<L1 14 - 18mm>					
1	S38586001	1	コウカンパーツL1クミ	EXCHANGE PARTS (L1) ASSY	
1-1	S37673001	1	イドウハL1R	MOVABLE KNIFE (L1)(R)	
1-2	S37669001	1	イドウハL1L	MOVABLE KNIFE (L1)(L)	
1-3	S37665000	1	イトサバキL1	THREAD HANDLER L1	
1-4	S37661001	1	イドウハクドウカムL1	MOVABLE KNIFE DRIVING CAM (L1)	
1-5	153787001	2	シメネジ2.38	SCREW, M2.38	
1-6	S37644001	1	ハリイタL1R	NEEDLE PLATE (L1)(R)	
1-7	S37643001	1	ハリイタL1L	NEEDLE PLATE (L1)(L)	
1-8	S37754001	1	ヌノオサエR-JL1	CLOTH PRESSER (R-J)(L1)	
1-9	S37755001	1	ヌノオサエL-JL1	CLOTH PRESSER (L-J)(L1)	
1-10	S37869000	1	シヨウハーネスL1	HARNESS (L1)	
1-11	S37702001	1	ハンマー-S12	HAMMER (S12)	
1-12	S37704001	1	ハンマー-S16	HAMMER (S16)	
<L2 18 - 22mm>					
1	S38587001	1	コウカンパーツL2クミ	EXCHANGE PARTS (L2) ASSY	
1-1	S37674001	1	イドウハL2R	MOVABLE KNIFE (L2)(R)	
1-2	S37670001	1	イドウハL2L	MOVABLE KNIFE (L2)(L)	
1-3	S37666000	1	イトサバキL2	THREAD HANDLER L2	
1-4	S37662001	1	イドウハクドウカムL2	MOVABLE KNIFE DRIVING CAM (L2)	
1-5	153787001	2	シメネジ2.38	SCREW, M2.38	
1-6	S37646001	1	ハリイタL2R	NEEDLE PLATE (L2)(R)	
1-7	S37645001	1	ハリイタL2L	NEEDLE PLATE (L2)(L)	
1-8	S37690001	1	ヌノオサエR-JL2	CLOTH PRESSER (R-J)(L2)	
1-9	S37689001	1	ヌノオサエL-JL2	CLOTH PRESSER (L-J)(L2)	
1-10	S37871000	1	シヨウハーネスL2	HARNESS (L2)	
1-11	S37704001	1	ハンマー-S16	HAMMER (S16)	
1-12	S37706001	1	ハンマー-S20	HAMMER (S20)	
<L3 22 - 26mm>					
1	S38588001	1	コウカンパーツL3クミ	EXCHANGE PARTS (L3) ASSY	
1-1	S37675001	1	イドウハL3R	MOVABLE KNIFE (L3)(R)	
1-2	S37671001	1	イドウハL3L	MOVABLE KNIFE (L3)(L)	
1-3	S37667000	1	イトサバキL3	THREAD HANDLER L3	
1-4	S37663001	1	イドウハクドウカムL3	MOVABLE KNIFE DRIVING CAM (L3)	
1-5	153787001	2	シメネジ2.38	SCREW, M2.38	
1-6	S37648001	1	ハリイタL3R	NEEDLE PLATE (L3)(R)	
1-7	S37647001	1	ハリイタL3L	NEEDLE PLATE (L3)(L)	
1-8	S37692001	1	ヌノオサエR-JL3	CLOTH PRESSER (R-J)(L3)	
1-9	S37691001	1	ヌノオサエL-JL3	CLOTH PRESSER (L-J)(L3)	
1-10	S37872000	1	シヨウハーネスL3	HARNESS (L3)	
1-11	S37706001	1	ハンマー-S20	HAMMER (S20)	
1-12	S37708001	1	ハンマー-S24	HAMMER (S24)	
<L4 26 - 30mm>					
1	S38589001	1	コウカンパーツL4クミ	EXCHANGE PARTS (L4) ASSY	
1-1	S37676001	1	イドウハL4R	MOVABLE KNIFE (L4)(R)	
1-2	S37672001	1	イドウハL4L	MOVABLE KNIFE (L4)(L)	
1-3	S37668000	1	イトサバキL4	THREAD HANDLER L4	
1-4	S37664001	1	イドウハクドウカムL4	MOVABLE KNIFE DRIVING CAM (L4)	
1-5	153787001	2	シメネジ2.38	SCREW, M2.38	
1-6	S37650001	1	ハリイタL4R	NEEDLE PLATE (L4)(R)	
1-7	S37649001	1	ハリイタL4L	NEEDLE PLATE (L4)(L)	
1-8	S37758001	1	ヌノオサエR-JL4	CLOTH PRESSER (R-J)(L4)	
1-9	S37759001	1	ヌノオサエL-JL4	CLOTH PRESSER (L-J)(L4)	
1-10	S37873000	1	シヨウハーネスL4	HARNESS (L4)	
1-11	S37708001	1	ハンマー-S24	HAMMER (S24)	
1-12	S37709001	1	ハンマー-S26	HAMMER (S26)	

118-980-940

仕様別部品一覧表/DIFFERENT PARTS LIST/ZUBEHÖRLISTE/
LISTE DES PIÈCES ACCESSOIRES/LISTA DE PIEZAS ACCESORIAS

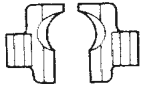
Ref.No. F-80-4,81-4 ヌノオサエ / CLOTH PRESSER

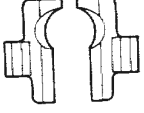
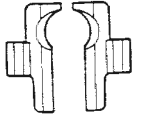
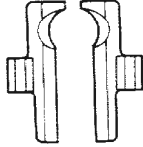
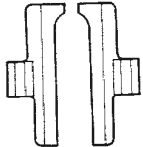
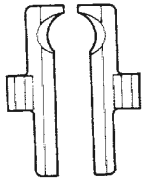
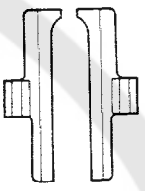
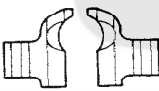
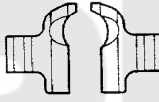
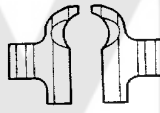
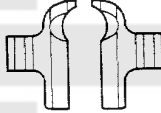
(L)	S35455-001	S39929-001	S35197-001	S39931-001
(R)	S35454-001	S39930-001	S35198-001	S39932-001
(-00 -01 用)	<10~18mm用>	<18~22mm用>	<22~26mm用>	<26~30mm用>
				
	S35453-001	S35200-101	S37679-001	S37677-101
	S35452-001	S35199-101	S37680-001	S37678-101
	<26~38mm用>	<38mm用>	<50mm用>	<50mm用>
				
(L)	S37755-001	S37689-001	S37691-001	S37759-001
(R)	S37754-001	S37690-001	S37692-001	S37758-001
(-02 用)	L1<14~18mm用>	L2<18~22mm用>	L3<22~26mm用>	L4<26~30mm用>
				

Ref.No. F-80-2,81-2 ハリイタ / NEEDLE PLATE

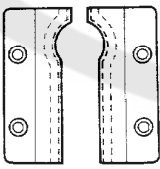
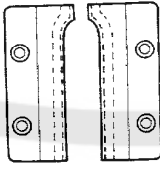
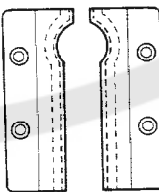
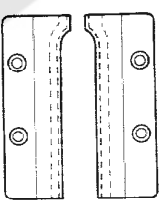
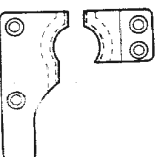
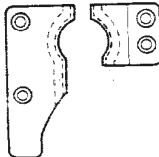
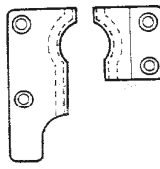
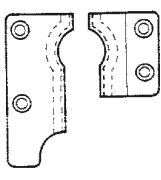
(L)	S35308-101(L)	S35307-101(SL)	S357683-101(L-50)	S37681-101(SL-50)
(R)	S35309-101(R)	S35306-101(SR)	S37684-101(R-50)	S37682-101(SR-50)
(-00 -01 用)	<38mm用>	<38mm用>	<50mm用>	<50mm用>
				
	(L)	S37643-101(L1L)	S37645-101(L2L)	S37647-101(L3L)
(R)	S37644-101(L1R)	S37646-101(L2R)	S37648-101(L3R)	S37650-101(L4R)
(-02 用)	L1<14~18mm用>	L2<18~22mm用>	L3<22~26mm用>	L4<26~30mm用>
				

仕様別部品一覧表/DIFFRENT PARTS LIST/ZUBEHÖRLISTE/
LISTE DES PIÈCES ACCESSOIRES/LISTA DE PIEZAS ACCESORIAS

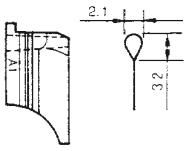
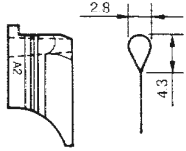
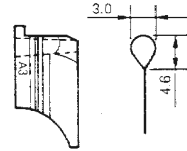
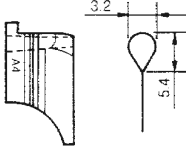
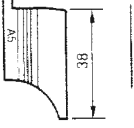
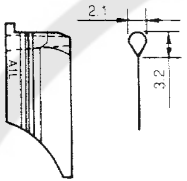
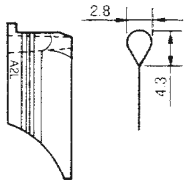
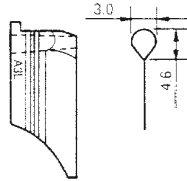
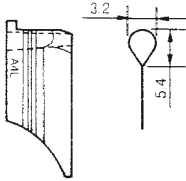
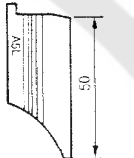
Ref.No. H-34-1,34-2 メス / KNIFE				
S35439-101 <38mm用> 	S35437-101 <38mm用> 	S35480-101 <38mm用> 	S35482-101 <38mm用> 	S35408-101 (S) <38mm用> 
S35438-101 <50mm用> 	S35436-101 <50mm用> 	S35481-101 <50mm用> 	S35483-101 <50mm用> 	S35409-101 (S) <50mm用> 

Ref.No. H-24-1,24-2,24-3 ハンマー /HAMMER					
(-00)	ハンマーサイズ(mm)	10	12	14	16
	部品コード	S37211-001	S37210-001	S37209-001	S37208-001
(-01用)	ハンマーサイズ(mm)	18	20	22	24
	部品コード	S37194-001	S35092-001	S37195-001	S37196-001
	ハンマーサイズ(mm)	26	28	30	32
	部品コード	S37197-001	S37198-001	S37199-001	S37200-001
(-02用)	ハンマーサイズ(mm)	34	36	38	50
	部品コード	S37201-001	S37202-001	S35093-001	S35479-001
	ハンマーサイズ(mm)	S10	S12	S14	S16
	部品コード	S37701-001	S37702-001	S37703-001	S37704-001
	ハンマーサイズ(mm)	S18	S20	S22	S24
	部品コード	S37705-001	S37706-001	S37707-001	S37708-001
	ハンマーサイズ(mm)	S26			
	部品コード	S37709-001			

索引/INDEX/VERZEICHIS/
INDEX/INDICE

CODE	REF.NO.	Page
S01694001	R1 -1-22	36
S01825001	W -1-5	48
S02403001	G -9	18
S02460001	G -19	18
	G -71	18
	G -76	18
S02687201	T -4	40
S02766009	Z -4	56
S03327000	T -9	40
S04557000	U -38	42
	V -5-4	46
	W -2-12	48
	a -1-4	60
	b -2-1-21	62
S04897000	U -42-3-1-6	44
	U -42-3-1-6	44
S05356000	a -1-2-7	60
	F2 -95	16
S05973001	V -7	46
S06696004	a -1-1-1-3	58
	a -1-2-1-3	60
	b -2-12	62
	F1 -55	10
	F1 -80-3	12
	F1 -81-3	12
	F2 -80-2-3	14
	F2 -81-2-3	14
S07885000	T -6	40
S08808001	a -1-2-8	60
	F2 -96	16
S09231000	U -42-1-1-2	44
S10077100	G -69	18
S10078001	G -80	18
S10079001	G -81	18
S10081001	G -49	18
S10082001	G -67	18
S10243000	U -5	42
	V -23	46
	V -28	46
S10439001	M -8	30
S10546000	V -6-1	46
S10856001	V -1-3	46
	V -2-2	46
	V -5-3	46
S11433000	U -9-3	42
S11730100	V -36	46
S11816000	V -21	46
	V -25	46
	V -27	46
S11817000	U -36	42
S12004000	G -18	18
	G -72	18
	G -75	18
S12104000	U -32	42
	U -57	42
	b -2-1-20	62
S12150000	U -1-1	42
	U -9-1	42
	U -10-1	42
	U -50-1	42
	b -2-1-13-1	62
S12160000	U -42-3-1-1	44
	U -42-3-1-1	44

CODE	REF.NO.	Page
S12161000	U -42-3-1-2	44
	U -42-3-1-2	44
S13955000	U -45	42
S17608009	B -65-1	4
S17965001	A -61	2
S18707129	J -17	24
S18707137	J -18	24
S20681000	Q -22	34
S20682102	Q -21	34
S20698001	Q -40	34
S21716001	a -1-1-22	58
S21728001	A -17	2
S23612001	B -38	4
	M -15	30
	N -9	30
S23651001	C -4	6
	C -6	6
	C -8	6
	K -7	24
	K -9	24
	K -11	24
S27844001	G -53	18
	G -61	18
S29410001	G -4	18
S31568000	G -79	18
S32109000	V -16-1	46
S32264009	A -91	2
S32354000	U -42-1-1-1	44
S33899000	A -78	2
S34881001	a -1-1-12	58
	R1 -1-5	36
	R2 -12	38
S34883001	R1 -1-12	36
S34884000	R1 -1-38	36
S34885001	R1 -1-34	36
S34886001	R1 -1-33	36
S34887001	R1 -1-32	36
S34888101	R1 -1-30-3	36
S34889101	R1 -1-30	36
S34890001	R1 -1-30-1	36
S34891101	R1 -1-30-2	36
S34892001	R1 -1-30-4	36
S34893001	R1 -1-28	36
S34894001	R1 -1-27	36
S34895001	R1 -1-25	36
S34896001	R1 -1-23	36
S34897001	R1 -1-21	36
S34898001	R1 -1-19-1	36
S34899001	R1 -1-19	36
S34900001	R1 -1-17	36
S34901001	R1 -1-16	36
S34902001	R1 -1-13	36
S34903001	R1 -1-11	36
S34904001	R1 -1-10	36
S34905101	R1 -1-8	36
S34906000	a -1-1-19	58
	R1 -1-6	36
	R2 -19	38
S34910101	R1 -1-4	36
S34913001	R1 -1-3	36
S34914001	R1 -1-1	36
S34915000	Z -5	56
S34916001	U -10-4	42

CODE	REF.NO.	Page
S34917001	Q -1-1	34
S34918101	Q -1-2	34
S34922001	b -2-1-3	62
S34922101	Q -1-4	34
	W -2-7	48
	F2 -102	16
S34923001	Q -13	34
S34924001	Q -26	34
S34925101	U -1-2	42
S34926001	Q -36	34
S34928001	Q -38	34
S34932001	Q -54	34
S34934001	Q -52	34
S34936001	Q -46-1	34
S34937001	Q -46-2	34
S34938001	Q -46-3	34
S34939001	Q -48	34
S34940001	Q -46-4	34
S34941001	Q -46-5	34
S34942001	Q -50	34
S34943001	Q -46-7	34
S34944001	Q -46	34
S34945000	T -1	40
S34946001	T -2	40
S34947001	T -11	40
S34948001	L1 -1	26
S34950009	G -1	18
S34957001	F1 -1	10
S34963001	F1 -2	10
S34964001	F1 -2-1	10
S34965001	F1 -1-1	10
S34966001	Q -1-3	34
	W -2-8	48
	F1 -3	10
S34967001	F1 -6	10
S34968000	F1 -12	10
S34969001	F1 -14	10
S34970001	F1 -13	10
S34971001	P -43	32
S34972000	P -42	32
S34973000	P -41	32
S34974000	P -38	32
S34979000	P -34	32
S34980000	P -33	32
S34981000	P -32	32
S34982000	P -31	32
S34983000	P -30	32
S34984000	P -29	32
S34985000	P -28	32
S34986000	P -27	32
S34987000	P -26	32
S34988000	P -25	32
S34989000	P -24	32
S34990000	P -23	32
S34991000	P -22	32
S34992000	P -21	32
S34993000	P -20	32
S34994000	P -18	32
S34995000	P -15	32
S34996001	P -13	32
S34997001	P -11	32
S34998001	P -9	32
S34999001	P -7	32

索引/INDEX/VERZEICHIS/
INDEX/INDICE

CODE	REF.NO.	Page
S35000001	P -5	32
S35001000	P -3	32
S35002000	P -2	32
S35003001	P -1	32
S35004001	W -1	48
S35005001	W -1-1	48
S35007000	L1 -2	26
S35010001	L1 -4	26
S35011001	L1 -10	26
S35012001	L1 -12	26
S35013001	L1 -16	26
S35014001	L1 -21	26
S35015001	L1 -14	26
S35016001	L1 -17	26
S35017001	L1 -19	26
S35018001	Q -46-6	34
	L1 -20	26
	L1 -62	26
S35019001	L1 -22	26
S35020001	L1 -23	26
S35021000	L1 -24	26
S35022001	L1 -25	26
S35023001	L1 -26	26
S35024101	L1 -28	26
S35025001	L1 -31	26
S35026001	L1 -38	26
S35027001	L1 -34	26
S35028000	L1 -35	26
S35029001	L1 -36	26
S35030001	L1 -42	26
S35032101	L1 -47	26
	L1 -52	26
S35033001	L1 -51	26
S35034001	L1 -50	26
S35035001	L1 -53	26
S35036001	L1 -54	26
S35037001	L1 -56	26
S35038001	L1 -58	26
S35039000	L1 -59	26
S35040000	L1 -61	26
S35041000	L1 -64	26
S35042000	L1 -66	28
S35043001	L1 -65	26
S35044001	L1 -67	28
S35045001	L1 -71	28
S35046000	L1 -73	28
S35048101	L1 -75	28
	L2 -75	38
S35049001	L1 -76	28
	L2 -76	38
S35050001	L1 -79	28
	L2 -79	38
S35051001	L1 -80	28
	L2 -80	38
S35052001	L1 -86	28
S35053001	L1 -9	26
S35054001	L1 -29	26
S35055001	L1 -87	28
S35056001	L1 -88	28
S35057001	L1 -92	28
	L2 -92	38
S35058001	S -1	40
S35059001	S -2	40

CODE	REF.NO.	Page
S35060001	S -5	40
S35061000	M -7	30
S35062001	M -6	30
S35063001	M -1-2	30
S35064001	M -1-3	30
S35065001	M -2	30
	N -8	30
S35066001	M -1	30
S35067001	M -1-1	30
S35068001	N -5	30
S35069001	N -2-3	30
S35070101	N -2-2	30
S35071001	N -2-1	30
S35072101	N -2	30
S35073001	N -1	30
S35074101	H -1	22
S35075101	H -1-1	22
S35076101	H -1-2	22
S35077000	H -1-3	22
S35078001	B -41	4
	H -1-4	22
	H -45	22
S35079000	H -1-5	22
S35080001	H -2	22
S35081001	H -5	22
S35082001	H -6	22
S35083001	H -13	22
S35084001	H -15	22
S35085001	H -8	22
S35086001	H -11	22
S35087001	H -10	22
S35088001	H -7	22
S35089001	H -17	22
S35090001	H -18	22
S35091001	H -23	22
S35092001	H -24-1	22
S35093001	H -24-2	22
S35094101	H -25-1	22
S35097001	H -25-2	22
S35098000	H -25-4	22
S35099001	H -39	22
S35100001	H -47	22
S35101001	H -51	22
S35102001	H -52	22
S35104001	H -54	22
S35106001	J -13	24
S35107001	J -10	24
S35108001	J -5	24
S35110001	J -1-2	24
S35112001	J -1	24
S35113001	B -66	4
S35114001	B -63	4
S35115001	B -62	4
S35116001	B -60	4
S35117001	B -59	4
S35118001	B -54	4
	b -2-9-4	62
	L1 -72	28
	L2 -107	38
S35119001	B -53	4
	b -2-9-3	62
	L2 -108	38
S35120001	B -52	4

CODE	REF.NO.	Page
S35120001	b -2-9-2	62
	L2 -106	38
S35121000	B -46	4
S35122000	B -45	4
S35123000	B -44	4
S35124000	B -43	4
S35125000	B -42	4
S35126001	B -40	4
S35127001	B -39	4
S35128001	B -36	4
S35129001	B -35-1	4
S35132101	B -35	4
S35133014	B -34	4
	Z -7	56
S35133016	B -34	4
	Z -7	56
S35133018	B -34	4
S35133118	Z -7	56
S35134001	B -32	4
S35135001	B -30	4
S35136001	B -29	4
S35137001	B -28	4
S35138001	B -26	4
S35142001	B -25	4
S35143001	D -24-1	6
S35144001	B -22	4
S35148001	B -19	4
S35151100	U -42-7	44
S35152000	V -1-1	46
S35153000	V -2-1	46
S35154000	V -5-1	46
S35157001	V -14	46
S35158000	V -14-1	46
S35159000	V -16	46
S35160000	V -6	46
S35161001	V -2	46
S35162001	V -14-2	46
S35164001	V -2-3	46
S35165009	V -17	46
S35166001	F1 -41	10
S35167001	F1 -80-14	12
S35168001	F1 -81-14	12
S35169001	F1 -16	10
S35171000	G -5	18
S35172000	G -45	18
S35173001	G -42	18
S35174001	G -51	18
S35175001	G -87	20
S35176001	G -2	18
S35177001	G -3	18
S35178001	G -12	18
S35179000	G -15	18
S35181001	G -11	18
S35182001	G -23	18
S35183000	G -26	18
S35184001	G -27	18
	G -73	18
S35185101	V -1-2	46
S35186001	G -55	18
S35187001	G -96	20
S35188001	G -16	18
S35189001	G -63	18
S35190001	G -70	18

索引/INDEX/VERZEICHIS/
INDEX/INDICE

CODE	REF.NO.	Page
S35191001	G -74	18
S35192001	G -84	20
S35194001	G -85	20
S35195001	G -91	20
S35196100	G -89	20
S35201000	A -40	2
S35202000	A -81	2
S35203001	A -23	2
S35204001	A -76	2
S35205001	A -72	2
S35206101	A -69	2
S35207001	A -67	2
S35208001	A -65	2
S35211009	A -66	2
S35212000	A -63	2
S35214009	A -62	2
S35215001	A -59	2
S35216001	A -57	2
S35217001	A -55	2
S35218001	A -47	2
S35219001	A -44	2
S35220001	A -41	2
S35221001	A -38	2
	A -70	2
S35222001	A -37	2
S35223001	A -34	2
S35224001	A -26	2
S35225000	A -15	2
S35226001	A -11	2
S35227009	A -8	2
S35228009	A -9	2
S35229000	A -7	2
S35231000	A -3	2
S35233101	F1 -81-12	12
	F2 -81-2-12	14
S35233201	a -1-2-1-12	60
S35234101	F1 -80-12	12
	F2 -80-2-12	14
S35234201	a -1-1-1-12	58
S35235001	S -10	40
	a -1-1-1-6	58
	a -1-2-1-6	60
	F1 -80-6	12
	F1 -81-6	12
	F2 -80-2-6	14
	F2 -81-2-6	14
S35236000	a -1-1-1-5	58
	a -1-2-1-5	60
	F1 -80-5	12
	F1 -81-5	12
	F2 -80-2-5	14
	F2 -81-2-5	14
S35237001	a -1-1-1-10	58
	F1 -80-10	12
	F1 -81-10	12
	F2 -80-2-10	14
S35238001	a -1-1-1-8	58
	F1 -80-8	12
	F1 -81-8	12
	F2 -80-2-8	14
S35239001	F1 -35	10
S35240001	F1 -36	10
S35241000	C -18	6

CODE	REF.NO.	Page
S35242009	C -12	6
S35245001	C -7	6
S35246001	C -5	6
S35247001	C -3	6
S35248001	C -1	6
S35249001	C -16	6
S35250001	D -20	6
S35251001	D -21	6
S35252001	D -18	6
S35255001	D -17	6
S35256001	D -15	6
S35257000	D -12	6
S35258001	D -10	6
S35259001	D -6	6
S35260001	D -5	6
S35262001	D -4	6
S35263101	D -2	6
S35264001	D -1	6
S35265001	K -12-2	24
S35268001	K -12-1	24
S35269001	K -12	24
S35270001	K -10	24
S35272001	K -8	24
S35273001	K -4	24
S35274001	K -6	24
S35275000	K -3	24
S35276001	E -1-1	8
S35277000	E -1-2	8
S35278001	E -1	8
S35283001	E -1-5	8
S35284001	E -11-1	8
	E -23-1	8
S35287001	E -23-4	8
S35288001	E -23	8
S35290001	E -11-4	8
S35291001	E -11	8
S35296001	E -15	8
S35297000	E -17	8
S35298001	V -5-2	46
S35299000	E -32	8
S35300000	E -31	8
S35302001	E -35	8
S35303101	F1 -39	10
S35304001	F1 -44	10
S35305001	U -3	42
	U -12	42
	U -51	42
	b -2-1-14	62
	F1 -42	10
S35308101	F1 -81-2	12
S35309101	F1 -80-2	12
S35310001	F1 -81-1	12
S35315001	a-1-1-1-1-1	58
S35316001	a-1-2-1-1-1	60
	F1 -80-1-1	12
	F1 -81-1-1	12
	F2 -80-2-1-1	14
	F2 -81-2-1-1	14
S35317001	F1 -81-1	12
S35318001	F1 -80-1	12
S35319001	F1 -80-1	12
S35321001	F1 -53	10
S35322001	F1 -54	10

CODE	REF.NO.	Page
S35323001	F1 -55	10
S35324001	F1 -57	10
S35326001	b -2-8	62
	F1 -80-17	12
	F1 -81-17	12
	F1 -81-20	12
	F2 -80-2-17	14
	F2 -81-2-17	14
	L1 -90	28
S35327001	F1 -62	10
S35328001	F1 -67	10
S35329001	F1 -81-18	12
S35330001	F1 -80-18	12
S35331001	B -17	4
S35332001	B -15	4
	D -22	6
S35333001	B -14	4
S35334001	B -13	4
S35335001	B -12	4
S35337001	B -8	4
S35338001	B -10	4
S35339001	B -2	4
S35340001	B -7	4
S35346001	B -1	4
S35347000	a -1-1-1-16	58
	F1 -80-16	12
	F2 -80-2-16	14
S35348000	a -1-2-1-16	60
	F1 -81-16	12
	F2 -81-2-16	14
S35349101	U -1	42
S35350000	U -7	42
S35351-00	U -50-2	42
S35351001	U -1-3	42
	U -10-3	42
	b -2-1-13-2	62
S35352001	U -10	42
S35353000	U -9	42
S35354000	U -31-1	42
S35355000	U -31	42
S35356000	U -31-1-1	42
S35357000	U -31-1-2	42
S35358000	U -8	42
S35359000	U -8-1	42
S35360000	U -14	42
S35361001	S -7	40
S35362001	S -8	40
S35364001	S -12	40
S35365101	L1 -81	28
S35366001	L1 -84	28
S35367000	U -17	42
S35368000	U -18	42
S35369000	U -19	42
S35370000	U -20	42
S35371000	U -21	42
S35372000	U -22	42
S35374000	U -24	42
S35375000	U -25	42
S35376000	U -26	42
S35377000	U -27	42
S35378000	U -28	42
S35379100	U -42-5	44
S35380100	U -42-6	44

索引|INDEX/VERZEICHIS/
INDEX/INDICE

CODE	REF.NO.	Page
S35382000	U -42-1-2	44
S35383000	U -42-3-1-3	44
	U -42-3-1-3	44
S35384100	U -42-3-4	44
	U -42-3-4	44
S35386000	U -42-1-1	44
S35389001	U -42-1	44
S35390101	U -42-3	44
S35391001	L1 -89-2	28
S35392001	L1 -89-2	28
S35393000	U -42-3-1	44
S35394001	U -42-3-6	44
	U -42-3-6	44
S35395000	U -42-1-3	44
S35396000	U -9-2	42
S35397000	U -10-2	42
S35398000	U -29	42
S35399000	U -30	42
S35405000	V -35	46
S35410001	L1 -45	26
S35411001	L1 -46-1	26
S35412001	L1 -48	26
S35413001	L1 -49-1	26
S35414000	P -16	32
S35417000	U -15	42
S35422001	U -42	44
S35423000	U -42-1-4	44
S35424000	U -42-1-5	44
S35425001	U -42-1-6	44
S35426000	U -14-1	42
S35428001	Q -46-9	34
S35429001	F1 -5	10
S35430001	Q -57-1	34
S35431001	J -1-1	24
S35433101	V -1	46
S35434001	V -5	46
S35436101	H -34-1	22
S35437101	H -34-2	22
S35452001	F1 -80-4	12
S35453001	F1 -81-4	12
S35456001	F1 -72	10
S35457001	F1 -73	10
S35458001	F1 -74	10
S35460000	U -44	42
S35461001	U -42	44
S35462101	U -42-3	44
S35463000	U -42-3-1	44
S35466001	Q -30	34
S35471001	L1 -46-2	28
S35472001	L1 -49-2	28
S35473101	H -25	22
S35474201	F1 -80	12
S35475201	F1 -81	12
S35476301	F1 -81	12
S35478301	F1 -80	12
S35479001	H -24-3	22
S35484001	Y -1	54
S35491001	Y -1-28	54
S35492001	Y -1-29	54
S35493001	Y -1-30	54
S35494001	Y -1-31	54
S35495001	Y -1-32	54
S35496001	Y -1-33	54

CODE	REF.NO.	Page
S35497001	Y -1-34	54
S35498001	Y -1-35	54
S35499001	Y -1-36	54
S35500001	Y -1-37	54
S35501001	Y -1-38	54
S35502001	Y -1-39	54
S35503001	Y -1-40	54
S35504001	Y -1-41	54
S35505001	Y -1-42	54
S35506001	Y -1-43	54
S35507001	Y -1-44	54
S35845001	Y -1-71	54
S35847001	Y -1-46	54
S35848001	Y -1-47	54
S35849001	Y -1-48	54
S35850001	Y -1-49	54
S35851001	Y -1-50	54
S35852001	Y -1-51	54
S35853001	Y -1-52	54
S35854001	Y -1-53	54
S35859001	Y -1-57	54
S35860001	Y -1-59	54
S35861001	Y -1-60	54
S35862001	Y -1-61	54
S35864001	Y -1-63	54
S35865001	Y -1-21	54
S35866001	Y -1-20	54
S35868001	Y -1-62	54
	Y -1-66	54
S35876001	Y -1-64	54
S35877001	Y -1-65	54
S35883001	Y -1-6	54
S35884001	Y -1-7	54
S35885001	Y -1-8	54
S35887001	Y -1-14	54
S35888001	Y -1-9	54
S35889001	Y -1-10	54
S35890001	Y -1-11	54
S35891001	Y -1-12	54
S35892001	Y -1-13	54
S35893001	Y -1-74	54
S35894001	Y -1-75	54
S35895001	Y -1-15	54
	Y -1-58	54
S35896001	Y -1-16	54
S35897001	Y -1-17	54
S35898001	Y -1-18	54
S35899001	Y -1-19	54
S35909000	U -16	42
S35911101	B -35-3	4
S35912001	Q -59	34
S35913001	X2 -1-1	50
S35914001	X2 -1-2	50
S35915001	X2 -1-3	50
S35916001	X2 -1-4	50
S35919001	X2 -1-10	50
	X2 -1-102	52
S35921001	X2 -1-13	50
S35922001	X2 -1-14	50
S35923001	X2 -1-15	50
S35924001	X2 -1-16	50
S35925001	X2 -1-17	50
S35926001	X2 -1-18	50

CODE	REF.NO.	Page
S35930001	X2 -1-20	50
S35934001	X2 -1-22	50
S35935001	X2 -1-23	50
S35936001	X2 -1-24	50
	X2 -1-54	50
S35937001	X2 -1-25	50
S35938001	X2 -1-26	50
S35939001	X2 -1-27	50
S35940001	X2 -1-28	50
S35941001	X2 -1-29	50
S35943001	X2 -1-31	50
S35945001	X2 -1-33	50
S35946001	X2 -1-34	50
S35947001	X2 -1-35	50
S35948001	X2 -1-36	50
S35949001	X2 -1-37	50
S35950001	X2 -1-38	50
S35953001	X2 -1-40	50
S35954001	X2 -1-41	50
S35955001	X2 -1-43	50
S35956001	X2 -1-44	50
S35957001	X2 -1-45	50
S35958001	X2 -1-46	50
S35959001	X2 -1-47	50
S35960001	X2 -1-48	50
S35961001	X2 -1-49	50
S35962001	X2 -1-51	50
S35963001	X2 -1-52	50
S35964001	X2 -1-53	50
S35965001	X2 -1-55	50
S35970001	X2 -1-62	50
S35971001	X2 -1-64	50
S35972001	X2 -1-66	50
S35973001	X2 -1-67	50
S35974001	X2 -1-68	50
	X2 -1-79	52
S35975001	X2 -1-70	50
S35976001	X2 -1-71	50
S35977001	X2 -1-72	50
S35978001	X2 -1-76	50
S35979001	X2 -1-77	52
S35980001	X2 -1-78	52
S35981001	X2 -1-80	52
S35982001	X2 -1-81	52
S35983001	X2 -1-82	52
S35985001	X2 -1-90	52
S35986001	X2 -1-92	52
S35987001	X2 -1-93	52
S35989001	X2 -1-103	52
S36321001	X2 -1-149	52
S36322001	X2 -1-150	52
S36323001	X2 -1-161	52
S36324001	X2 -1-163	52
S36325001	X2 -1-165	52
S36326001	X2 -1-166	52
S36327001	X2 -1-167	52
S36328001	X2 -1-166-1	52
S36329001	X2 -1-166-2	52
S36330001	X2 -1-166-3	52
S36332001	X2 -1-180	52
S36334001	X2 -1-42	50
S36336001	X2 -1-91	52
S36345000	F1 -58	10

索引/INDEX/VERZEICHIS/
INDEX/INDICE

CODE	REF.NO.	Page
S36381000	V -37	46
S36382000	V -38	46
S36532100	U -42-3-4-5	44
	U -42-3-4-5	44
S36659001	L1 -95	28
S36660001	L1 -43	26
S36681000	V -39	46
S36682000	V -40	46
S36683000	P -19	32
S36742000	U -42-3-4-4	44
	U -42-3-4-4	44
S36743000	U -42-3-4-3	44
	U -42-3-4-3	44
S36744000	U -42-3-4-2	44
	U -42-3-4-2	44
S36753000	U -42-3-4-1	44
	U -42-3-4-1	44
S36884001	Y -1-76	54
S36885001	X1 -1-191	48
S36886001	X1 -1-191	48
S36887001	X1 -1-191	48
S36888001	X1 -1-191	48
S36889001	X1 -1-191	48
S36890001	X1 -1-191	48
S36891001	X1 -1-191	48
S37084001	A -93	2
S37085001	A -93-1	2
S37087001	B -20	4
S37088001	B -67	4
S37173000	P -46	32
S37432001	B -23	4
	D -24	6
	L1 -7	26
S37616000	Y -1-99-1	54
S37617000	Y -1-99-1	54
S37618000	Y -1-99	54
S37643001	a -1-2-1-2	60
	c -1-7	64
	F2 -81-2-2	14
S37644001	a -1-1-1-2	58
	c -1-6	64
	F2 -80-2-2	14
S37645001	a -1-2-1-2	60
	c -1-7	64
	F2 -81-2-2	14
S37646001	a -1-1-1-2	58
	c -1-6	64
	F2 -80-2-2	14
S37647001	a -1-2-1-2	60
	c -1-7	64
	F2 -81-2-2	14
S37648001	a -1-1-1-1	58
	c -1-6	64
	F2 -80-2-2	14
S37649001	a -1-2-1-2	60
	c -1-7	64
	F2 -81-2-2	14
S37650001	a -1-1-1-1	58
	c -1-6	64
	F2 -80-2-2	14
S37652001	a -1-1-16	58
	R2 -16	38
S37653001	a -1-1-17	58

CODE	REF.NO.	Page
S37653001	R2 -17	38
S37654000	a -1-1-8	58
	R2 -8	38
S37655001	a -1-1-9	58
	R2 -9	38
S37656001	a -1-1-11-1	58
	R2 -11	38
S37659001	a -1-1-21	58
	R2 -21	38
S37660001	a -1-1-6	58
	R2 -6	38
S37661001	a -1-1-5	58
	c -1-4	64
	R2 -5	38
S37662001	a -1-1-5	58
	c -1-4	64
	R2 -5	38
S37663001	a -1-1-5	58
	c -1-4	64
	R2 -5	38
S37664001	a -1-1-5	58
	c -1-4	64
	R2 -5	38
S37665000	a -1-1-4	58
	c -1-3	64
	R2 -4	38
S37666000	a -1-1-4	58
	c -1-3	64
	R2 -4	38
S37667000	a -1-1-4	58
	c -1-3	64
	R2 -4	38
S37668000	a -1-1-4	58
	c -1-3	64
	R2 -4	38
S37669001	a -1-1-3	58
	c -1-2	64
	R2 -3	38
S37670001	a -1-1-3	58
	c -1-2	64
	R2 -3	38
S37671001	a -1-1-3	58
	c -1-2	64
	R2 -3	38
S37672001	a -1-1-3	58
	c -1-2	64
	R2 -3	38
S37673001	a -1-1-2	58
	c -1-1	64
	R2 -2	38
S37674001	a -1-1-2	58
	c -1-1	64
	R2 -2	38
S37675001	a -1-1-2	58
	c -1-1	64
	R2 -2	38
S37676001	a -1-1-2	58
	c -1-1	64
	R2 -2	38
S37679001	F1 -81-4	12
S37680001	F1 -80-4	12
S37683101	F1 -81-2	12
S37684101	F1 -80-2	12

CODE	REF.NO.	Page
S37689001	a -1-2-1-4	60
	c -1-9	64
	F2 -81-2-4	14
S37690001	a -1-1-1-4	58
	c -1-8	64
	F2 -80-2-4	14
S37691001	a -1-2-1-4	60
	c -1-9	64
	F2 -81-2-4	14
S37692001	a -1-1-1-2	58
	c -1-8	64
	F2 -80-2-4	14
S37693001	b -2-11	62
	F2 -75	16
S37694001	a -1-2-1-14	60
	F2 -81-2-14	14
S37695001	a -1-1-1-14	58
	F2 -80-2-14	14
S37696001	b -2-9-1	62
	L2 -29	38
S37697001	Q -57-2	34
	b -2-5	62
S37700001	a -1-1-24	58
	R2 -24	38
S37702001	a -1-5	60
	c -1-11	64
S37704001	a -1-5	60
	a -1-6	60
	c -1-12	64
	c -1-11	64
S37706001	a -1-5	60
	a -1-6	60
	c -1-12	64
	c -1-11	64
S37708001	a -1-5	60
	a -1-6	60
	c -1-12	64
	c -1-11	64
S37709001	a -1-6	60
	c -1-12	64
S37711001	a -1-2-1-10	60
	F2 -81-2-10	14
S37712001	a -1-2-1-8	60
	F2 -81-2-8	14
S37713001	a -1-2-3	60
	F2 -91	16
S37714001	a -1-2-2	60
	F2 -90	16
S37717001	b -2-1-2	62
	F2 -101	16
S37718000	a -1-2-5	60
	F2 -93	16
S37720001	b -2-10-11	62
	L2 -38	38
S37721001	b -2-10-4	62
	L2 -101	38
S37723001	b -2-10-9	62
	L2 -36	38
S37724001	b -2-10-6	62
	L2 -103	38
S37725001	b -2-10-7	62
	L2 -104	38
S37726001	b -2-10-1	62

索引/INDEX/VERZEICHIS/
INDEX/INDICE

CODE	REF.NO.	Page
S37726001	L2 - 31	38
S37727001	a - 1-1-1	58
S37727201	F2 - 80-2	14
S37728001	a - 1-2-1	60
S37728201	F2 - 81-2	14
S37729001	a - 1-1-1-1	58
	F2 - 80-2-1	14
S37730001	a - 1-2-1-1	60
	F2 - 81-2-1	14
S37731001	a - 1-2-1	60
S37731201	F2 - 81-2	14
S37732001	a - 1-2-1	60
S37732201	F2 - 81-2	14
S37733001	a - 1-1-1	58
S37733201	F2 - 80-2	14
S37735001	a - 1-2-1	60
S37735201	F2 - 81-2	14
S37737001	U - 50	42
	b - 2-1-13	62
S37738000	U - 53	42
	b - 2-1-16	62
S37739000	U - 54	42
	b - 2-1-17	62
S37744001	b - 2-1-1	62
	F2 - 99	16
S37745001	Q - 63	34
	b - 2-1-8	62
S37749001	Q - 64	34
	b - 2-1-9	62
S37750001	Q - 68	34
	b - 2-3	62
S37752001	b - 2-7	62
	L2 - 89	38
S37753001	a - 1-2-10	60
	F2 - 98	16
S37754001	a - 1-1-1-4	58
	c - 1-8	64
	F2 - 80-2-4	14
S37755001	a - 1-2-1-4	60
	c - 1-9	64
	F2 - 81-2-4	14
S37756001	a - 1-1-1	58
S37756201	F2 - 80-2	14
S37757001	a - 1-1-1	58
	F2 - 80-2	14
S37758001	a - 1-1-1-2	58
	c - 1-8	64
	F2 - 80-2-4	14
S37759001	a - 1-2-1-4	60
	c - 1-9	64
	F2 - 81-2-4	14
S37820001	a - 1-1-14-1	58
	R2 - 14	38
S37858000	a - 1-1-23	58
	R2 - 23	38
S37863000	U - 55	42
	b - 2-1-18	62
S37864000	U - 56	42
	b - 2-1-19	62
S37866-00	U - 50-3	42
S37866000	b - 2-1-13-3	62
S37869000	a - 1-3	60
	c - 1-10	64

CODE	REF.NO.	Page
S37870000	F2 - 104	16
S37871000	a - 1-3	60
	c - 1-10	64
S37872000	a - 1-3	60
	c - 1-10	64
S37873000	a - 1-3	60
	c - 1-10	64
S37874101	Q - 1	34
S38335000	F1 - 81-19	12
S38572001	a - 1	58
S38573001	a - 1	58
S38574001	a - 1	58
S38575001	a - 1	58
S38576101	a - 1-1	58
S38577101	a - 1-2	60
S38578101	a - 1-1	58
S38579101	a - 1-2	60
S38580101	a - 1-1	58
S38581101	a - 1-2	60
S38582101	a - 1-1	58
S38583101	a - 1-2	60
S38584001	b - 2	62
S38585001	b - 2-1	62
S38586001	c - 1	64
S38587001	c - 1	64
S38588001	c - 1	64
S38589001	c - 1	64
S38887001	L1 - 89-1	28
S38888001	L1 - 89-2	28
S39108001	b - 2-10	62
S39109001	b - 2-9	62
S39909001	W - 2	48
S39910001	W - 2-4	48
S39911001	W - 2-5	48
S39912001	W - 2-6	48
S39913001	W - 2-1	48
S39914001	W - 2-2	48
S39915000	W - 2-3	48
004300513	A - 79	2
004401003	a - 1-1-25	58
	R1 - 1-35	36
	R2 - 25	38
008300604	A - 62-1	2
012060636	B - 38-1	4
012400636	Q - 33	34
012500536	G - 86	20
014060622	B - 65-2	4
014060632	A - 56	2
	A - 58	2
	A - 68	2
	B - 3	4
	B - 9	4
	B - 11	4
	B - 37	4
	C - 13	6
	D - 13	6
	E - 1-6	8
	E - 36	8
	G - 17	18
	G - 90	20
	G - 97	20
	H - 9	22
	H - 12	22

CODE	REF.NO.	Page
014060632	H - 14	22
	H - 16	22
	H - 19	22
	J - 12	24
	J - 14	24
	M - 1-4	30
	M - 14	30
	N - 10	30
	S - 16	40
014060832	L1 - 27	26
014300532	B - 47	4
014300832	L1 - 94	28
014400432	S - 6	40
014400532	a - 1-1-1-15	58
	a - 1-2-1-15	60
	F1 - 45	10
	F1 - 80-15	12
	F1 - 81-15	12
	F2 - 80-2-15	14
	F2 - 81-2-15	14
014760622	G - 10	18
	G - 50	18
	G - 68	18
014770622	G - 54	18
	G - 62	18
	G - 62	18
016061031	H - 3	22
017401415	F1 - 63	10
018061022	G - 77	18
018061236	A - 60	2
018061622	E - 2	8
	G - 43	18
	G - 88	20
018062022	D - 11	6
018062522	H - 27	22
018081636	J - 2	24
018082036	A - 82	2
018084032	Z - 23	56
018260832	R1 - 1-26	36
018300532	L1 - 96	28
018301236	B - 16	4
	D - 23	6
018301632	B - 23-1	4
	D - 24-2	6
	L1 - 7-1	26
018400832	A - 35	2
	B - 64	4
	E - 14	8
	E - 24	8
	H - 53	22
	R1 - 1-2	36
018401022	S - 15	40
	R1 - 1-9	36
	R2 - 22	38
018401032	a - 1-2-6	60
	F2 - 94	16
018401236	Q - 2	34
018401636	E - 18	8
	G - 24	18
018402032	B - 21	4
018501036	B - 33	4
018501222	A - 42	2
	H - 26	22
018501236	a - 1-1-1-13	58

索引/INDEX/VERZEICHIS/
INDEX/INDICE

CODE	REF.NO.	Page
018501236	a -1-2-1-13	60
	F1 -80-13	12
	F1 -81-13	12
	F2 -80-2-13	14
	F2 -81-2-13	14
018501422	E -1-3	8
	G -52	18
018501622	G -46	18
	H -25-3	22
018501631	G -6	18
	G -13	18
	G -83	20
	G -100	20
018502022	K -16	24
018502036	U -42-3-2	44
018503036	U -42-3-2	44
018680822	G -82	18
021020106	R1 -1-30-6	36
021060102	A -22	2
	D -9	6
021060306	Q -31	34
021080306	D -3	6
021300205	A -74	2
021300206	A -62-2	2
021300302	S -11	40
	a -1-1-1-7	58
	a -1-2-1-7	60
	b -2-10-3	62
	F1 -80-7	12
	F1 -81-7	12
	F2 -80-2-7	14
	F2 -81-2-7	14
	L1 -33	26
021350106	N -6	30
	S -9	40
	R1 -1-14	36
021400106	Q -46-8	34
021400202	A -71	2
	S -13	40
	W -2-9	48
	a -1-1-7	58
	a -1-1-13	58
	b -2-1-4	62
	F1 -64	10
	F2 -103	16
	L1 -57	26
	R1 -1-40	36
	R2 -7	38
	R2 -13	38
021500106	Z -4-4-2	56
	Z -4-7-3	56
	Z -4-11-3	56
021500303	B -35-2	4
021630102	b -2-10-8	62
	L2 -105	38
021660102	a -1-2-9	60
	F2 -97	16
025030232	A -62-3	2
025040232	G -25	18
	N -4	30
	Q -66	34
	T -13	40
	V -32	46

CODE	REF.NO.	Page
025040232	V -34	46
	b -2-1-11	62
	F1 -7	10
025040234	V -4	46
025050232	E -1-4	8
	G -8	18
	G -48	18
	K -17	24
025060332	A -20	2
025080132	A -83	2
025080232	Z -25	56
025350236	L1 -82	28
	L2 -82	38
025680132	L1 -77	28
	L2 -77	38
028030242	M -9	30
028030243	V -10	46
	V -14-4	46
028040242	H -56	22
	F1 -19	10
	F1 -71	10
028050242	A -43	2
028050243	U -42-3-3	44
	U -42-3-3	44
028050246	Z -4-7-2	56
028060242	G -78	18
028080242	J -4	24
	Z -24	56
031312006	W -1-6	48
031452206	Z -4-11-4	56
031553202	U -42-2	44
	U -42-4	44
032422003	U -35	42
034311302	W -1-3	48
047502242	A -30	2
	A -51	2
048030342	U -4	42
	U -13	42
	U -52	42
	b -2-1-15	62
	F1 -15	10
	F1 -43	10
	L1 -78	28
	L2 -78	38
048050142	a -1-1-1-11	58
	a -1-2-1-11	60
	a -1-2-4	60
	F1 -80-11	12
	F1 -81-11	12
	F2 -80-2-11	14
	F2 -81-2-11	14
	F2 -92	16
048050342	S -4	40
	F1 -1-4	10
	F1 -2-4	10
048060342	G -57	18
	G -65	18
048080142	A -45	2
	A -48	2
048100142	E -11-5	8
	E -23-5	8
048120142	J -1-5	24
	K -12-5	24

CODE	REF.NO.	Page
048150142	C -11	6
	K -2	24
048160242	G -66	18
048260242	E -11-3	8
	E -23-3	8
048280242	G -93	20
	J -1-3	24
	K -12-4	24
048320242	J -7	24
048350242	C -17	6
060020416	a-1-1-1-1-2	58
	a-1-2-1-1-2	60
	F1 -80-1-2	12
	F1 -81-1-2	12
	F2 -80-2-1-2	14
	F2 -81-2-1-2	14
060300416	L1 -39	26
	L1 -60	26
060300616	A -73	2
	W -2-11	48
060350616	a -1-1-1-17	58
	a -1-2-1-17	60
	b -2-10-12	62
	L2 -39	38
060400516	L1 -30	26
060400816	W -2-13	48
060630312	R1 -1-39	36
061300416	R1 -1-24	36
062020416	R1 -1-30-5	36
062020805	T -5	40
062260406	R1 -1-15	36
062260612	a -1-1-20	58
	R1 -1-7	36
	R2 -20	38
062300416	G -28	18
	G -99	20
	H -25-5	22
	P -12	32
	P -17	32
	P -44	32
	a -1-1-18	58
	R1 -1-41	36
	R2 -18	38
062300512	A -64	2
	A -77	2
	B -68	4
	R1 -1-29	36
062300612	L1 -13	26
	L1 -44	26
062300616	A -80	2
	B -31	4
062300806	V -14-3	46
062301016	b -2-10-2	62
	F1 -11	10
	L1 -32	26
062301606	V -8	46
062350516	L1 -83	28
	L2 -83	38
062350616	P -4	32
	P -37	32
	Q -7	34
	Q -27	34
	Q -45	34







索引/INDEX/VERZEICHIS/
INDEX/INDICE

CODE	REF.NO.	Page
062350616	U -41	42
062351615	L1 -3	26
062400612	Q -37	34
	Q -39	34
062400616	P -6	32
	P -8	32
	P -10	32
	a -1-1-15	58
	R2 -15	38
062400812	A -12	2
	A -24	2
	A -27	2
	H -40	22
	H -48	22
	H -55	22
	N -3	30
	Q -29	34
	Q -47	34
	Q -49	34
	Q -51	34
	Q -53	34
	Q -56	34
	Q -58	34
	Q -69	34
	U -6	42
	V -3	46
	V -15	46
	V -18	46
	V -22	46
	V -30	46
	V -31	46
	V -33	46
	b -2-2	62
	b -2-4	62
	b -2-6	62
	F1 -8	10
	F1 -17	10
	F1 -65	10
	F2 -100	16
	L1 -85	28
062400816	U -37	42
062401016	T -12	40
	a -1-1-1-9	58
	a -1-2-1-9	60
	F1 -80-9	12
	F1 -81-9	12
	F2 -80-2-9	14
	F2 -81-2-9	14
062401212	Q -67	34
	b -2-1-12	62
062401416	L1 -63	26
062401616	T -14	40
062403515	U -42-3-5	44
	U -42-3-5	44
062500804	A -6	2
062500812	A -54	2
062501006	T -8	40
	Z -4-11-2	56
062501202	A -4	2
	A -10	2
	F1 -38	10
	F1 -40	10
	L1 -11	26

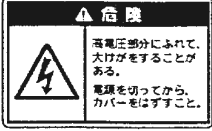
CODE	REF.NO.	Page
062501202	L1 -18	26
062501406	Z -4-4-1	56
072620180	E -16	8
072620260	C -2	6
076000800	E -11-2	8
	E -23-2	8
076001800	G -92	20
	J -1-4	24
	K -12-3	24
076001850	E -33	8
076002450	C -10	6
076002800	J -6	24
076003850	K -1	24
	L1 -93	28
076202850	K -5	24
100257010	A -93-3	2
101572101	Z -9	56
102630001	F1 -1-2	10
	F1 -2-2	10
102843004	C -23	6
104336003	R1 -1-37	36
105288001	b -2-10-10	62
	L1 -37	26
106129002	A -93-4	2
107017002	A -39	2
	A -88	2
109763002	F1 -1-3	10
	F1 -2-3	10
113006001	P -14	32
113431002	T -7	40
114483002	Z -18	56
114486002	A -53	2
115947001	A -19	2
116920001	C -21	6
	J -11	24
117150001	P -36	32
117466000	Z -19	56
117936009	A -89	2
118837001	Z -8	56
140342001	Z -21	56
140553102	B -18	4
140682001	U -42-3-1-4	44
	U -42-3-1-4	44
141276001	C -22	6
141542001	a -1-1-10	58
	R1 -1-20	36
	R2 -10	38
142627001	E -34	8
142642001	H -46	22
143196001	P -39	32
	P -40	32
	P -45	32
143485001	V -41	46
144103009	Q -19	34
144504001	Q -41	34
	Q -60	34
	b -2-1-5	62
	L1 -70	28
145446001	Q -11	34
146124001	W -2-10	48
147236001	Q -65	34
	b -2-1-10	62
148407001	b -2-10-5	62

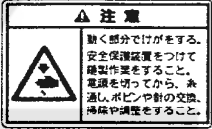
CODE	REF.NO.	Page
148407001	L2 -102	38
148727001	D -19	6
148782001	G -101	20
149796001	Z -6	56
150607009	A -75	2
150644009	Q -32	34
150756009	A -92	2
151998000	C -20	6
152889001	Q -44	34
152904001	R1 -1-36	36
152948001	P -35	32
152969001	U -40	42
153098000	A -93-2	2
153219001	R1 -1-18	36
153274001	U -42-3-1-5	44
	U -42-3-1-5	44
153596001	D -26	6
153675001	B -27	4
153787001	a -1-1-26	58
	c -1-5	64
	R2 -28	38
154465001	A -52	2
154562001	Q -42	34
	Q -61	34
	b -2-1-6	62
	L1 -68	28
154702101	Z -20	56
155510001	Q -43	34
	Q -62	34
	b -2-1-7	62
	L1 -69	28
155559001	D -7	6
158437009	A -90	2
158581000	U -34	42
158827009	A -14	2
159150009	W -1-4	48
	Z -26	56
159220101	Q -10	34
159221001	Q -20	34
159458009	A -18	2
159805001	Q -18	34
226391001	T -3-1	40
237941001	T -3	40
340400001	U -39	42
530138001	G -56	18
	G -64	18
542515001	R1 -1-31	36
552907000	V -29	46

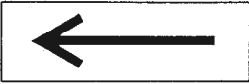
警告ラベル／Warning labels／Warnschilder／
Etiquettes d'avertissement／Etiquetas de advertencia

	品名／Name of parts	Size(mm)	Code
	電撃ラベル・和	40×64	S38353-001
	Label, elec. shock 4 lang.	35×118	S38352-001
	操作注意ラベル・和	40×64	S38350-001
	Label, operation Eng.	40×64	S38349-001
	ワーニングマーク Mark, injury	L=16 R=0.8	S36924-001
	矢印マーク Mark, arrow	10×30	S37058-001
	アースマーク Mark, grounding	φ12	S37060-001