

BM-917B

パーツブック
PARTS BOOK

単環ボタン付け自動糸切りミシン

CHAIN STITCH BUTTON SEWER WITH THREAD TRIMMER

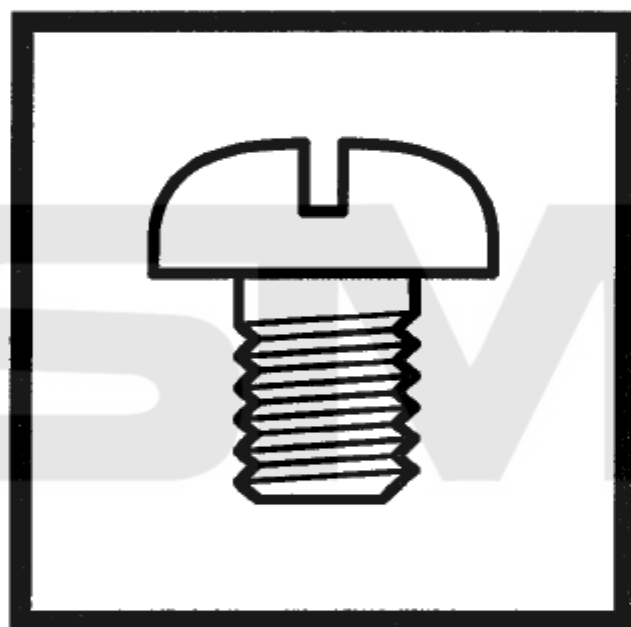

brother®

BROTHER INDUSTRIES, LTD.

• **BM-917B-00** ■ •

A

A	縫い模様 / Stitch pattern	針数 / Number of stitches
1	コの字縫い ボタン付け縫い	8,16,32
2	Button sewing in invert "C" shape	6,12,24
3	Z字縫い ボタン付け縫い	8,16,32
4	Button sewing "Z" shape	6,12,24
5	X字縫い ボタン付け縫い	8,16,32
6	Button sewing "X" shape	6,12,24
7	仮ラベル付け縫い	8,16,32
8	Temporally label attaching stitch	6,12,24

パーツブックご利用に際して

1. この本は、2002年9月のデータに基づいて作成されたものです。
2. 部品は予告なしに設計変更される場合があります。
3. 組単位で補給する部品は、 破線で示してあります。
4. 部品コード欄が※となっている場合は、仕様別部品一覧表(33ページ)でお調べ下さい。

目 次

A. 主体関係	1
B. 針数変換関係	1
C. 駆動・停止関係	3
D. 針棒駆動関係	5
E1. 送り関係	7
E2. 送り関係	9
F. 押エ上げ関係	11
G. 下軸関係	13
H. 系サバキ関係	13
J. 系通シ関係	15
K. 系切り関係	17
L1. オプションパーツ	17
L2. オプションパーツ	19
L3. オプションパーツ	21
L4. オプションパーツ	23
L5. オプションパーツ	25
L6. オプションパーツ	27
L7. オプションパーツ	27
Z1. 付属品関係	29
Z2. 付属品関係(オプションパーツ)	31
Sp. 仕様別部品一覧表	33
Wa. 警告ラベル	34
索引	35

Notes for using this parts book

1. This book was prepared based on information available in September 2002.
2. Parts are subject to changes in design without prior notice.
3. Parts supplied as complete assemblies are circled by a dotted line [] .
4. If the symbol * is found in the " Parts No." column, refer to the different parts lists, gauge parts list on page 33.

CONTENTS

A. Machine body.	1
B. Stitch number conversion.	1
C. Driving clutch and brake mechanism.	3
D. Needle bar rocking mechanism.	5
E1. Feed mechanism.	7
E2. Feed mechanism.	9
F. Presser foot lifter mechanism.	11
G. Lower shaft mechanism.	13
H. Loop spreading mechanism.	13
J. Threading mechanism.	15
K. Thread trimmer mechanism.	17
L1. Option parts.	17
L2. Option parts.	19
L3. Option parts.	21
L4. Option parts.	23
L5. Option parts.	25
L6. Option parts.	27
L7. Option parts.	27
Z1. Accessories.	29
Z2. Accessories (Option parts).	31
Sp. Different parts list.	33
Wa. Warning labels.	34
INDEX.	35

A. 主体関係 / Machine body

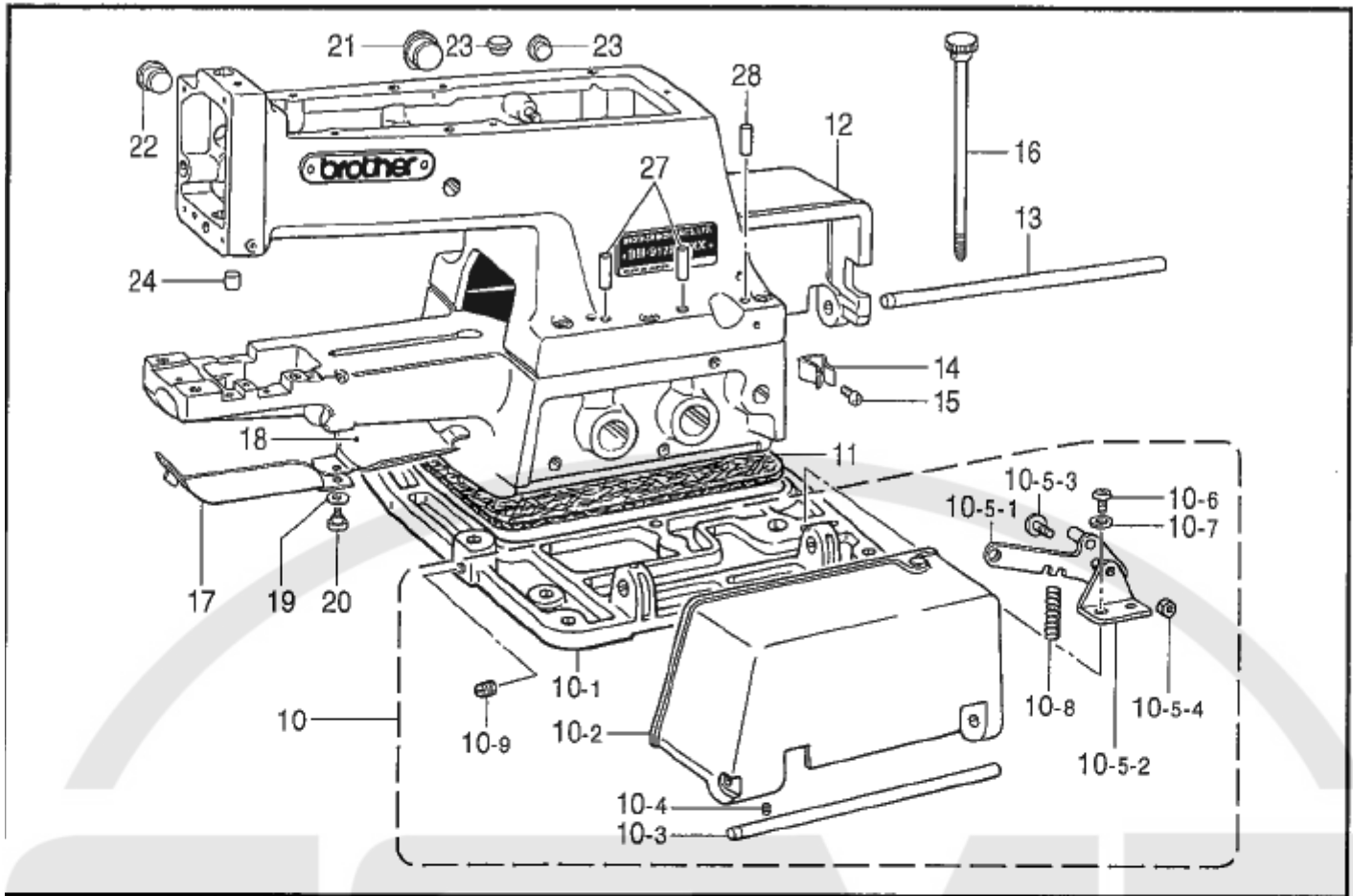

878-917-050

B. 針数変換関係 / Stitch number conversion

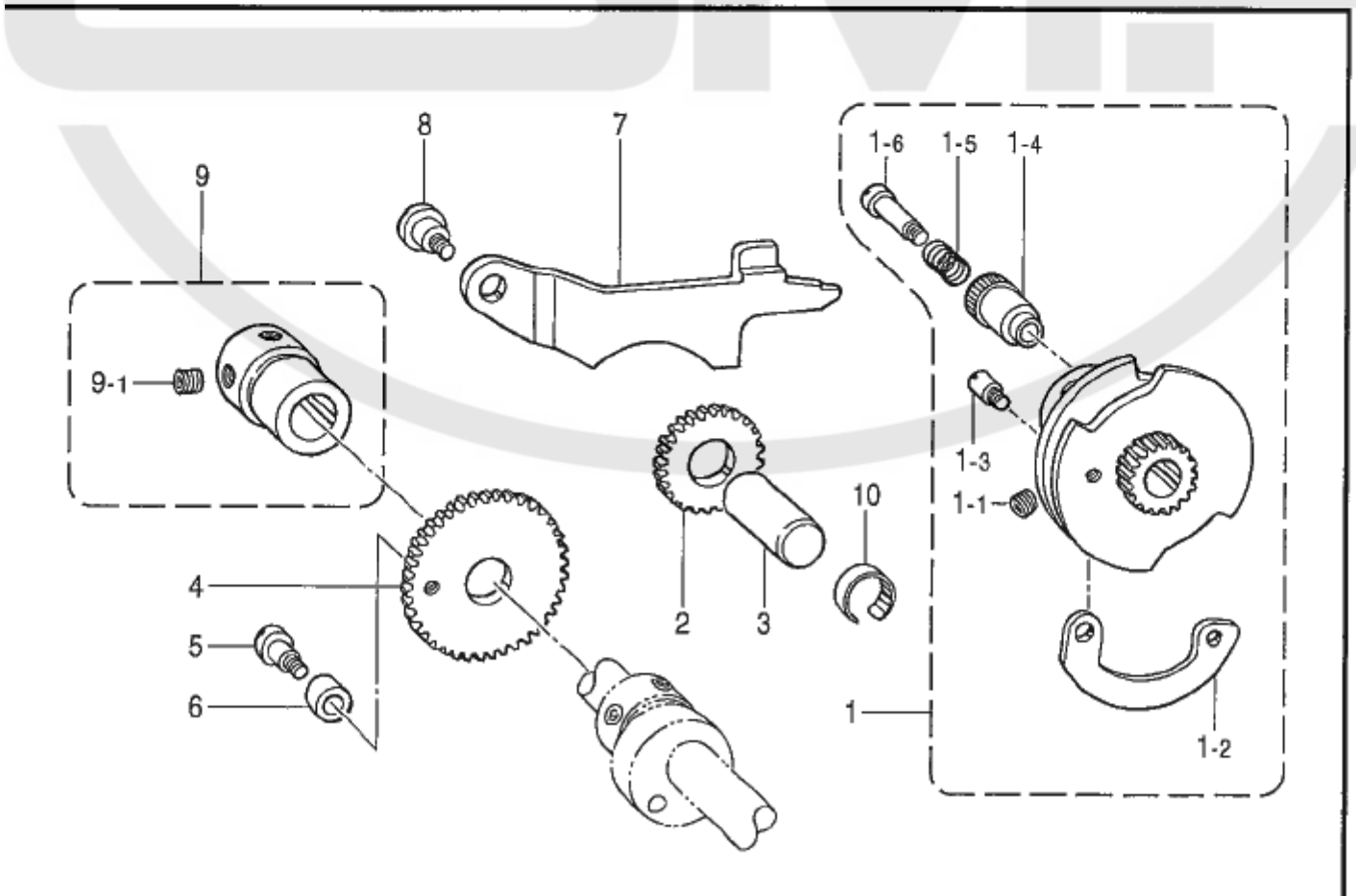

878-917-129

A. 主体関係 / Machine body

REF.NO	CODE	Q'TY	ヒンメイ	NAME OF PARTS	RM
10	S36590009	1	ベッドベース	BED BASE ASSY	
10-1	S36591000	1	ベッドベース	BED BASE	
10-2	S03372109	1	ベッドカバー(R)	BED COVER (R) ASSY	
10-3	114984000	1	ベッドカバーシャフト	BED COVER SHAFT	
10-4	014761030	2	ソケット付きネジ	SET SCREW, SOCKET (CP) SM5.95X10	
10-5	S07995001	1	クラッチレバー	CLUTCH LEVER ASSY	
10-5-1	142307101	1	クラッチレバー駆動機構	CLUTCH DRIVING LEVER ASSY	
10-5-2	115025001	1	クラッチレバー駆動プレート	CLUTCH DRIVING LEVER PLATE	
10-5-3	115268002	1	ネジ M5.56	SCREW, M5.56	
10-5-4	021750112	1	ナット SM5.56-32	NUT, 1 SM5.56-32	
10-6	062711212	2	ネジ SM4.76-32X12	SCREW, PAN SM4.76-32X12	
10-7	025710232	2	ワッシャー M4.76	WASHER, PLAIN M 4.76	
10-8	S36816001	1	クラッチレバーバネ	SPRING	
10-9	100251001	2	ネジ SM6.35-40X6.5	SET SCREW, (CP) SM6.35-40X6.5	
11	114982000	1	ベッドベースフェルト	BED BASE FELT	
12	S03374109	1	ベッドカバー(L)	BED COVER (L) ASSY	
13	114984000	1	ベッドカバーシャフト	BED COVER SHAFT	
14	114985001	2	ベッドカバープレートバネ	SPRING, PLATE	
15	062680512	2	ネジ SM4.37-40X5	SCREW, PAN SM4.37-40X5	
16	114986101	1	ボルト	BOLT	
17	115275001	1	ルーパーカバー	LOOPER COVER	
18	S03376001	1	カバー	COVER	
19	105329001	1	ワッシャー	WASHER	
20	114988001	1	タレット M4.37	SHOULDER SCREW, M4.37	
21	108520001	1	ゴムキャップ 19.8	RUBBER CAP, 19.8	
22	117934001	1	ゴムキャップ 13.5	RUBBER CAP, 13.5	
23	117936001	2	ゴムキャップ 9.4	RUBBER CAP, 9.4	
24	110104000	1	ゴムキャップ 5	RUBBER CAP, 5	
27	106436001	4	フェルト	FELT	
28	147691000	2	フェルト	FELT	

878-917-050

B. 針数変換関係 / Stitch number conversion

REF.NO	CODE	Q'TY	ヒンメイ	NAME OF PARTS	RM
1	*	1	ハリカスハンカシカム	STITCH CONTROL CAM ASSY	
1-1	014821022	2	ネジ SM7.94	SET SCREW, SOCKET (CP) SM7.94	
1-2	S03433001	1	ハリカスカム	STITCH CONTROL CAM SEGMENT	
1-3	115113001	1	タレット M4.37	SCREW 4.37	
1-4	115114001	1	ハリカスハンカシノブ	STITCH CONTROL KNOB	
1-5	115115001	1	バネ	SPRING	
1-6	115116001	1	タレット M4.37	SHOULDER SCREW, M4.37	
2	S03436001	1	ハリカスハンカシギヤ	STITCH CHANGING (M) GEAR	
3	115118001	1	ハンカシギヤスタッド	STITCH CHANGING (M) GEAR STUD	
4	S03437001	1	ハリカスハンカシギヤ	STITCH CHANGING GEAR	
5	S03438001	1	タレット M4.37	SHOULDER SCREW, SM4.37	
6	S03439001	1	ローラー 7.94	ROLLER 7.94	
7	S03440001	1	針 32	STITCH 32 LEVER	
8	S03441001	1	タレット M4.76	SHOULDER SCREW, SM4.76	
9	S03442001	1	セットカラー	SET SCREW COLLAR ASSY	
9-1	014770622	2	ネジ SM6.35	SET SCREW, SOCKET (CP) SM6.35	
10	S05724001	1	リング	RETAINING RING	

878-917-129

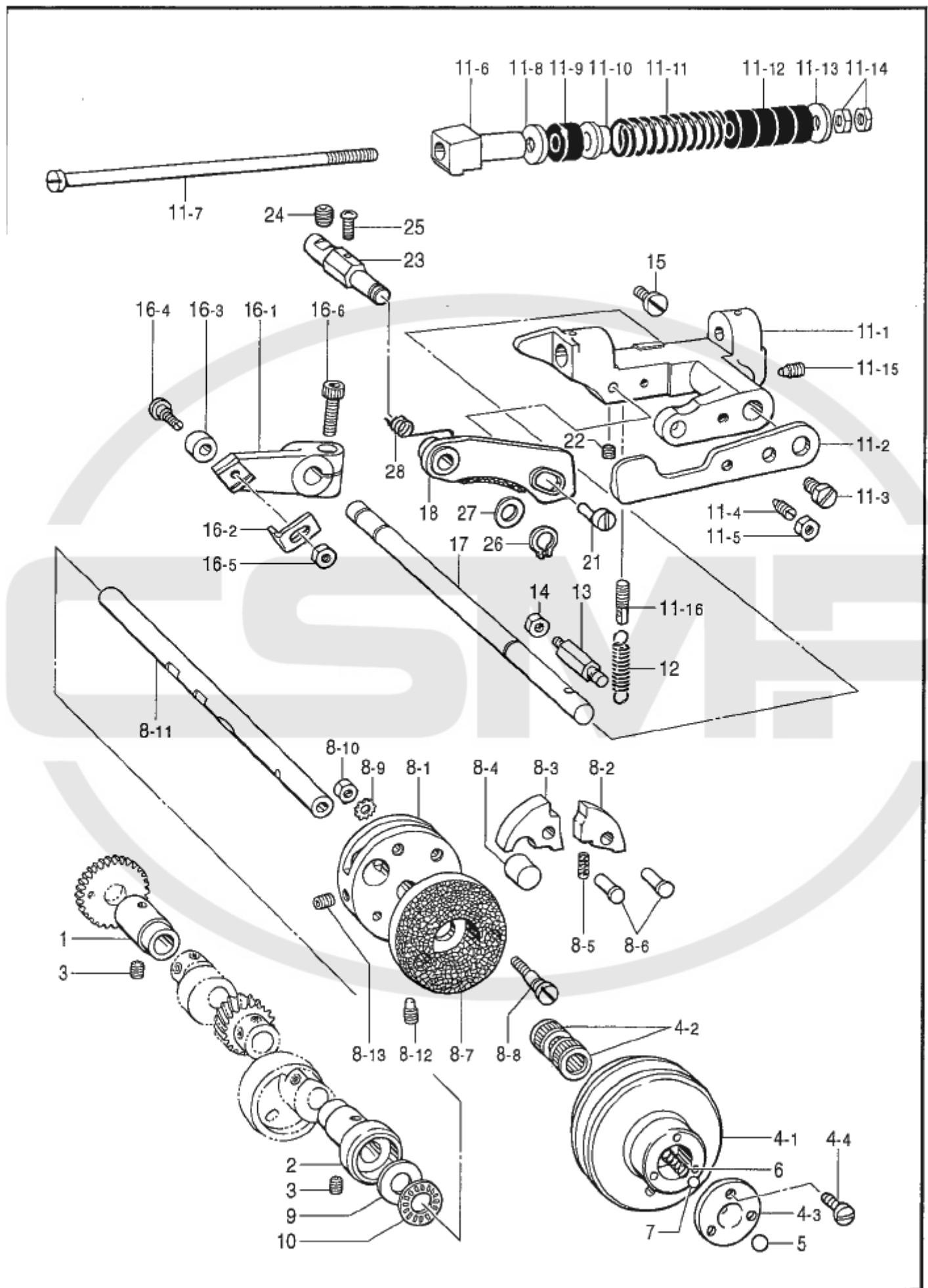

C. 駆動・停止関係 / Driving clutch and brake mechanism

REF.NO	CODE	QTY	ヒンメイ	NAME OF PARTS	RM
1	115215100	1	ク ^ト ウジ ^ク メタ ^{RL}	DRIVING SHAFT BUSH (L)	
2	S03378000	1	ク ^ト ウジ ^ク メタ ^{RR}	DRIVING SHAFT BUSH (R)	
3	013760712	2	トメネジ ^{5.95} ホ ^ミ	SET SCREW, (CP) SM5.95	
4	S03379101	1	プ ^ー リー ^ク ミ	PULLEY ASSY	
4-1	S34341001	1	プ ^ー リー	PULLEY	
4-2	114992000	2	ニ ^ー トル ^ハ ア ^リ ン ^ク	NEEDLE BEARING	
4-3	S34340001	1	ホ ^ー ル ^ウ ケ	BALL HOLDER	
4-4	112751003	3	シメネジ ^{3.57}	SCREW, SM3.57X7	
5	071079450	1	コウキユウ ^{5/16}	BEARING BALL, 5/16	
6	114997001	1	プ ^ー リー ^ト シ ^オ シ ^ハ ネ	SPRING	
7	071055650	1	コウキユウ ^{7/32}	BEARING BALL, 7/32	
8	S03381101	1	ストツフ ^カ ム ^ク ミ	STOP CAM ASSY	
8-1	S03382101	1	ストツフ ^カ ム	STOP CAM	
8-2	S03383001	1	セ ^イ ト ^ウ カ ^ム ヘ ^ン	BRAKE CAM SEGMENT	
8-3	S03384001	1	ストツフ ^カ ムヘ ^ン	STOP CAM SEGMENT	
8-4	S03385000	1	カ ^ン シ ^ヨ ウ ^コ ム	CUSHION RUBBER	
8-5	S03386001	1	ストツフ ^カ ム ^ハ ネ	SPRING	
8-6	115004001	2	カ ^ム ヘ ^ン シ ^ク	CAM SEGMENT STUD	
8-7	S03387001	1	ク ^ラ ツ ^チ イ ^タ	CLUTCH PLATE	
8-8	S05725001	2	シメネジ ^{5.56}	SCREW, M5.56	
8-9	115000000	2	ハ ^ツ キ ^サ カ ^ネ	TOOTHED WASHER	
8-10	021750112	2	1 ^シ ユ ^ナ ツ ^ト 556-32	NUT, 1 SM5.56-32	
8-11	S03388001	1	ク ^ト ウジ ^ク	DRIVING SHAFT	
8-12	149996001	1	ストツフ ^カ ム ^セ ツ ^ト ネ ^ジ	STOP CAM SET SCREW	
8-13	014821022	1	ア ^ナ ト ^メ ネ ^ジ ^{7.94} ホ ^ミ	SET SCREW, SOCKET (CP) SM7.94	
9	S10668001	1	サ ^カ ネ	WASHER	
10	115008000	1	タ ^マ シ ^ク ウ ^ケ	BALL BEARING	
11	S36615001	1	ク ^ラ ツ ^チ タイ ^ク ミ	CLUTCH BODY ASSY	
11-1	S36616001	1	ク ^ラ ツ ^チ タイ	CLUTCH BODY	
11-2	S03392001	1	ホ ^ー ル ^オ サ ^イ イ ^タ	BALL PRESSER PLATE	
11-3	115011201	1	ホ ^ー ルト ^{6.35}	BOLT, M6.35	
11-4	115012002	1	トメネジ ^{6.35}	SET SCREW, SM6.35	
11-5	150554002	1	ナ ^ツ ト ^{6.35}	NUT, SM6.35	
11-6	S03393001	1	ストツハ ^ー タイ	STOPPER BRACKET	
11-7	S03394001	1	ストツハ ^ー シ ^ク	STOPPER SHAFT	
11-8	025800332	1	ヒ ^ラ サ ^カ ネ ^タ ^{17.14}	WASHER, PLAIN L 7.14	
11-9	S03395000	1	カ ^ン シ ^ヨ ウ ^コ ム	CUSHION RUBBER	
11-10	S34806001	1	ハ ^ネ ウ ^ケ	SPRING HOLDER	
11-11	S36693001	1	ク ^ラ ツ ^チ ストツハ ^ー ハ ^ネ	CLUTCH STOPPER SPRING	
11-12	115018001	4	カ ^ン シ ^ヨ ウ ^コ ム	CUSHION RUBBER	
11-13	025800332	1	ヒ ^ラ サ ^カ ネ ^タ ^{17.14}	WASHER, PLAIN L 7.14	
11-14	021800102	2	ナ ^ツ ト ^{1シ} ユ ^{7.14}	NUT, 1 SM7.14	
11-15	149996001	1	ストツフ ^カ ム ^セ ツ ^ト ネ ^ジ	STOP CAM SET SCREW	
11-16	S03401001	1	ハ ^ネ カ ^ケ	SPRING HOOK	
12	S03402001	1	ク ^ラ ツ ^チ ヒ ^キ ハ ^ネ	SPRING	
13	115022001	1	ハ ^ネ カ ^ケ	SPRING HOOK	
14	102571003	1	ナ ^ツ ト ^{4.37}	NUT, SM4.37	
15	S03403001	1	ストツハ ^ー ネ ^ジ	STOPPER SCREW	
16	S36694001	1	セ ^イ キ ^ヨ レ ^ハ ク ^ミ	REGULATING LEVER ASSY	
16-1	S03405101	1	ハ ^リ カ ^ス セ ^イ キ ^ヨ レ ^ハ	STITCH CONTROL LEVER	
16-2	S36695001	1	ツ ^メ	CLAW	
16-3	S03407001	1	コ ^ロ	ROLLER	
16-4	S03408001	1	コ ^ロ タ ^ン ネ ^ジ	SHOULDER SCREW	
16-5	110161004	1	ナ ^ツ ト ^{4.76}	NUT, SM4.76	
16-6	018062022	1	ア ^ナ ホ ^ー ルト ^{6X20}	BOLT, SOCKET M6X20	
17	S35727001	1	ク ^ラ ツ ^チ タイ ^シ ク	CLUTCH BODY SHAFT	
18	S37362001	1	プ ^レ キ ^レ ハ ^ー ク ^ミ	BRAKE LEVER ASSY	
21	S36642001	1	プ ^レ キ ^レ ハ ^ー シ ^ク	BRAKE LEVER SHAFT	
22	014710522	1	ア ^ナ ト ^メ ネ ^ジ ^{4.76} ホ ^ミ	SET SCREW, SOCKET (CP) SM4.76	
23	S37133001	1	プ ^レ キ ^シ ヤ ^{フト}	BRAKE SHAFT	
24	014760622	1	ア ^ナ ト ^メ ネ ^ジ ^{5.95}	SET SCREW, SOCKET SM5.95	
25	S20740101	1	シメネジ ^{4X10} シ ^ル	SCREW, SEAL M4X10	
26	048080142	1	ト ^メ ウ ^シ ク ^ヨ ウ ^{C8}	RETAINING RING, C8	
27	153596001	1	サ ^カ ネ	WASHER	
28	S36700001	1	プ ^レ キ ^レ ハ ^ー ハ ^ネ	SPRING	

D . 針棒驅動關係 / Needle bar and driving clutch mechanism

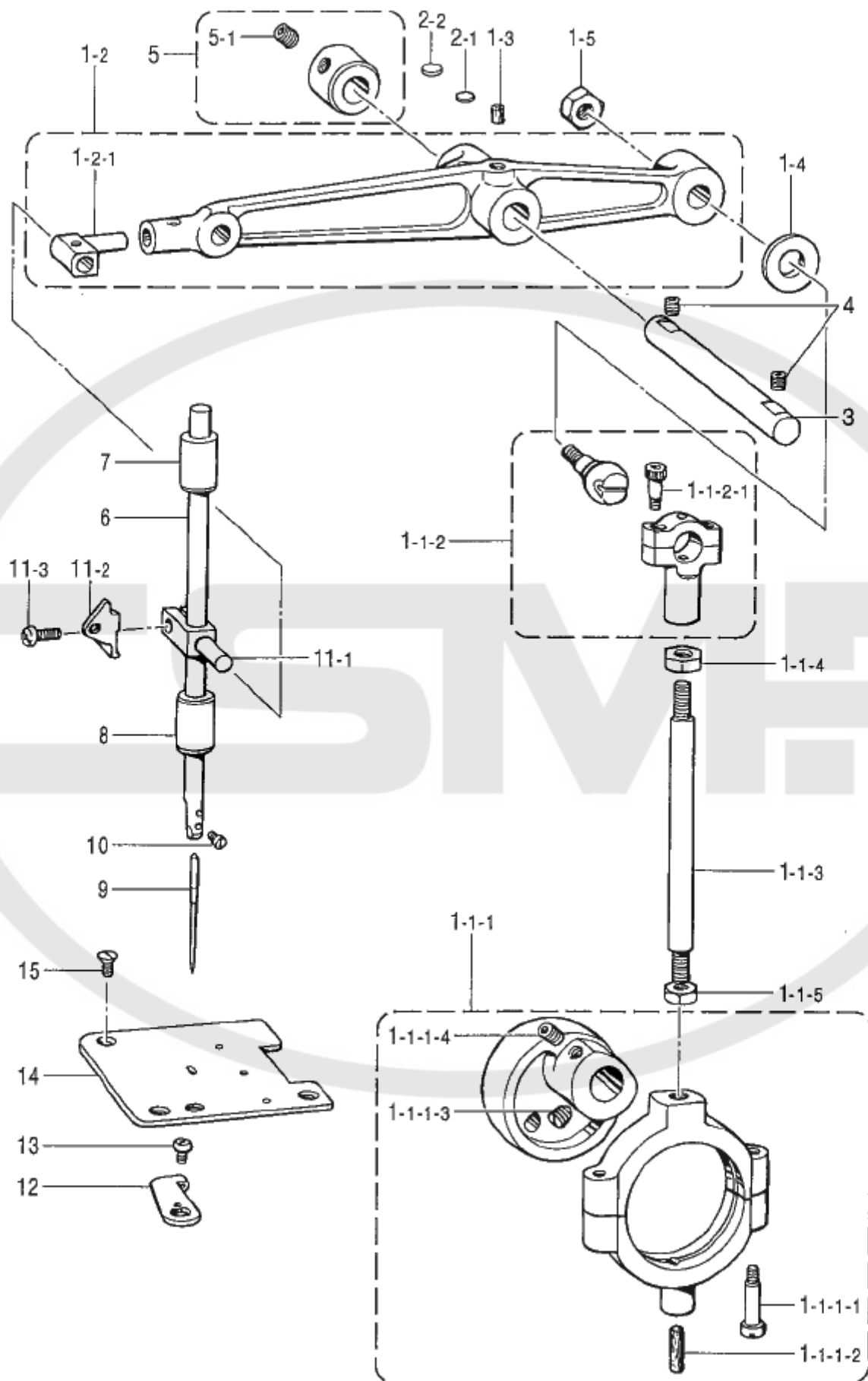

D. 針棒駆動関係 / Needle bar and driving clutch mechanism

REF.NO	CODE	QTY	品名	NAME OF PARTS	RM
1	S03409001	1	ハリ棒ウツクミ	NEEDLE BAR DRIVING ASSY	
1-1	S03410001	1	クランクロッドクミ	CRANK ROD ASSY	
1-1-1	S03719001	1	クランクロッドLタンクミ	LOWER CRANK ROD (L) ASSY	
1-1-1-1	142658001	2	シメネジ 4.37	SCREW, M4.37	
1-1-1-2	S03412000	1	クランクロッドフェルト	FELT	
1-1-1-3	015770812	1	トメネジ 6.35トガリ	SET SCREW, (CN) SM6.35	
1-1-1-4	014770622	1	アタメネジ 6.35ソケット	SET SCREW, SOCKET (CP) SM6.35	
1-1-2	S03720001	1	クランクロッドSタンクミ	UPPER CRANK ROD (S) ASSY	
1-1-2-1	148425002	2	アタネソケット 4.37X14	BOLT, SOCKET SM4.37X14	
1-1-3	S03414001	1	ロッド	CRANK ROD	
1-1-4	021800102	1	ナット 1.7.14	NUT, 1 SM7.14	
1-1-5	115042001	1	ナット 7.14	NUT 7.14	
1-2	S03415001	1	ハリ棒ウツクミレバークミ	NEEDLE BAR DRIVING LEVER ASSY	
1-2-1	115048101	1	ハリ棒ウツクミキツキテ	NEEDLE BAR BRACKET	
1-3	S03417000	1	ウツクミレバークミフェルト	FELT	
1-4	S03418000	1	ワッシャー	WASHER	
1-5	105812003	1	ナット 7.94	NUT, SM7.94	
2-1	S03419001	1	カンザ	SPACER	
2-2	141674002	1	ワックスベースキャップ	WICK BASE CAP	
3	S03420001	1	ウツクミレバークミシャフト	NEEDLE BAR DRIVING LEVER SHAFT	
4	014760622	2	アタメネジ 5.95	SET SCREW, SOCKET SM5.95	
5	S03421001	1	セツカラークミ	SET SCREW COLLAR ASSY	
5-1	014770632	2	アタメネジ 6.35-40X6	SET SCREW, SOCKET (CP) SM6.35X6	
6	S03423001	1	ハリ棒	NEEDLE BAR	
7	S03424000	1	ハリ棒ウツクミ	NEEDLE BAR BUSH (U)	
8	S03425000	1	ハリ棒ウツクミ	NEEDLE BAR BUSH (D)	
9	115053016	1	ミシンハリTQX1 (#16)	NEEDLE, TQX1 (#16)	
10	140553102	1	アタメネジ 3.18	SET SCREW, SM3.18	
11	S03426101	1	ハリ棒ウツクミ	NEEDLE BAR CLAMP ASSY	
11-1	S03427101	1	ハリ棒ウツクミ	NEEDLE BAR CLAMP	
11-2	S03428001	1	スレッド	THREAD TAKE-UP	
11-3	062671212	1	ネジ 3.57-40X12	SCREW, PAN SM3.57-40X12	
12	S03429101	1	ハリガード	NEEDLE GUARD	
13	062710612	1	ネジ 4.76-32X6	SCREW, PAN SM4.76-32X6	
14	S36622001	1	ハリプレート	NEEDLE PLATE	
15	S01702001	3	マルサラネジ 4.37X10	SCREW, OVAL SM4.37X10	

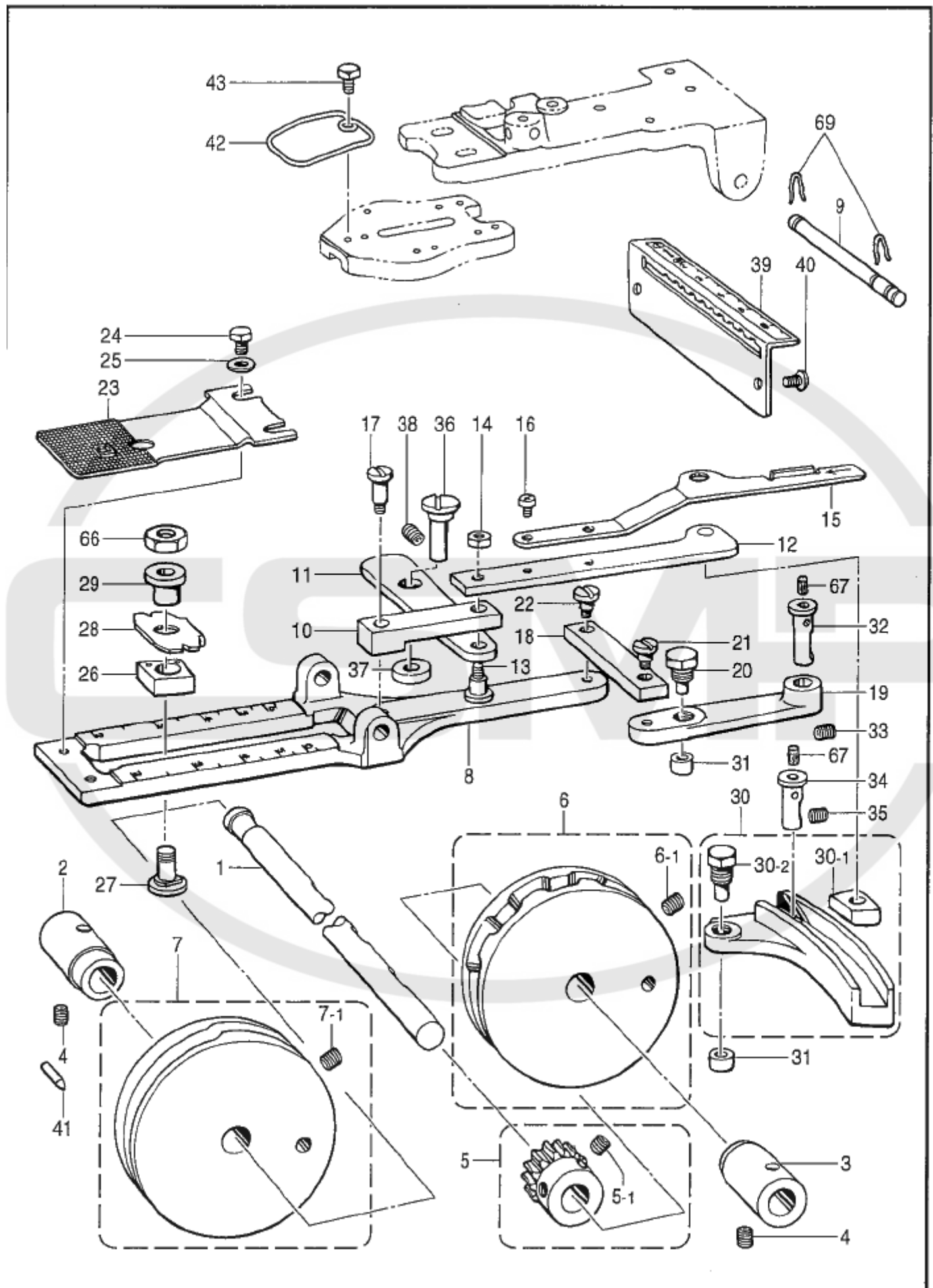

E1. 送り関係 / Feed mechanism

REF.NO	CODE	QTY	ヒンメイ	NAME OF PARTS	RM
1	115078101	1	カムシフト	CAM SHAFT	
2	S03444000	1	カムシフトメタル	CAM SHAFT BUSH (L)	
3	115080000	1	カムシフトメタルR	CAM SHAFT BUSH (R)	
4	013760712	2	トメネジ 5.95xホミ	SET SCREW, (CP) SM5.95	
5	*	1	ウォームギヤ	WORM GEAR ASSY	
5-1	014770622	2	アトメネジ 6.35xホミ	SET SCREW, SOCKET (CP) SM6.35	
6	*	1	ヨコオリカム	TRANSVERSE FEED CAM ASSY	
6-1	014770622	2	アトメネジ 6.35xホミ	SET SCREW, SOCKET (CP) SM6.35	
7	*	1	タテオリカム	VERTICAL FEED CAM ASSY	
7-1	014770622	2	アトメネジ 6.35xホミ	SET SCREW, SOCKET (CP) SM6.35	
8	S36626001	1	オリダイ	FEED BAR	
9	S37444001	1	ホダンツカミホルダシフト	HOLDER BAR	
10	S03471001	1	タテオリリンクA	VERTICAL FEED LINK (A)	
11	S03472001	1	タテオリリンクB	VERTICAL FEED LINK (B)	
12	S03473001	1	タテオリレンガ	VERTICAL FEED CONNECT ROD ASSY	
13	S03474001	1	タンネジ 4.76	SHOULDER SCREW, SM4.76	
14	021710102	1	ナット1x24.76	NUT, 1 SM4.76	
15	115105001	1	タテオリ調整レバー	VERTICAL FEED ADJUST LEVER	
16	062680512	2	ナット437-40X5	SCREW, PAN SM4.37-40X5	
17	115101001	1	タンネジ 4.76	SHOULDER SCREW, M4.76	
18	115094001	1	オリリンク	FEED LINK	
19	115096000	1	ヨコオリレバー	TRANSVERSE FEED LEVER	
20	115097001	1	オリコロシフト	ROLLER SHAFT	
21	115095001	1	タンネジ 4.76	SHOULDER SCREW, M4.76	
22	115095001	1	タンネジ 4.76	SHOULDER SCREW, M4.76	
23	S03476101	1	オリダイA	FEED PLATE, A	
24	146360002	2	ボルト4.76X7	BOLT, SM4.76X7	
25	S10667001	2	ワッシャー	WASHER	
26	S03478101	1	ヨコオリ調整ブロック	TRANSVERSE FEED SLIDE BLOCK	
27	S31724001	1	ヨコオリ調整ネジ	SCREW	
28	S03480001	1	ヨコオリ調整プレート	TRANSVERSE FEED PLATE	
29	S31723001	1	ヨコオリ調整シャフト	ADJUSTING SHAFT	
30	S03482101	1	タテオリ調整ブロック	BACK & FORTH FEED SLIDE BLOCK ASSY	
30-1	S03484101	1	タテオリ調整ブロック	BACK & FORTH FEED SLIDE BLOCK	
30-2	115097001	1	オリコロシフト	ROLLER SHAFT	
31	115098001	2	オリコロ	ROLLER	
32	115099001	1	オリダイレバー	FEED LEVER SHAFT	
33	014760622	1	アトメネジ 5.95	SET SCREW, SOCKET SM5.95	
34	S03485001	1	タテオリレバー	VERTICAL FEEDING LEVER SHAFT	
35	014760622	1	アトメネジ 5.95	SET SCREW, SOCKET SM5.95	
36	S03486001	1	オリダイレバー	FEED LEVER SHAFT	
37	S03611001	1	カラーS	COLLAR, S	
38	014760622	1	アトメネジ 5.95	SET SCREW, SOCKET SM5.95	
39	115108301	1	タテオリ長さ指示	BACK & FORTH FEED LENGTH INDICATOR	
40	062711012	2	ナット476-32X10	SCREW, PAN SM4.76-32X10	
41	114980001	1	カム位置ピン	POSITIONING PIN	
42	151051201	1	フィンガード	FINGER GUARD	
43	146360002	1	ボルト4.76X7	BOLT, SM4.76X7	
66	150556001	1	ナット6.35	NUT, SM6.35	
67	S09043000	2	フェルト	FELT	
69	S39092000	2	スナップリテーナ	SNAP RETAINER 5	

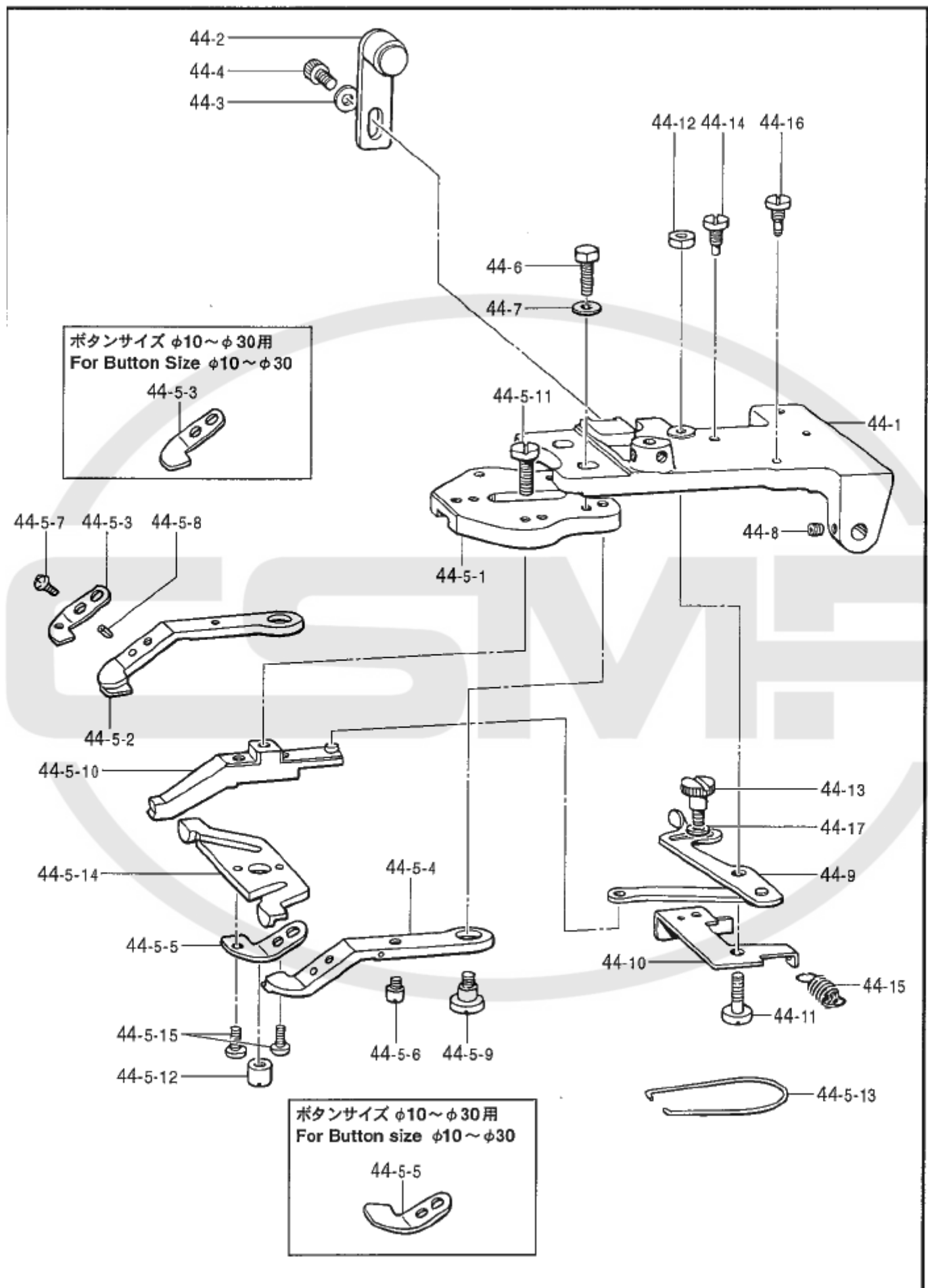

E2. 送り関係 / Feed mechanism

REF.NO	CODE	Q'TY	ヒンメイ	NAME OF PARTS	RM
			<共通部品>	<COMMON PARTS>	
44-1	S37352009	1	押しウデ	PRESSER ARM	
44-2	S03459051	1	押しウデ調整プレート	PRESSER ADJUSTING PLATE ASSY	
44-3	S03695001	1	ワッシャー	WASHER, PLAIN 6	
44-4	018061022	1	ボルト	BOLT, SOCKET M6X10	
44-5-1	S03464101	1	ボタンクランプ	BUTTON CLAMP BRACKET	
44-5-6	115156001	2	ガイドピン	GUIDE PIN	
44-5-7	062680512	2	ネジ	SCREW, PAN SM4.37-40X5	
44-5-8	047250642	2	スプリングピン	PIN, SPRING ROLL AW2.5	
44-5-9	115158001	2	ネジ	SHOULDER SCREW, SM4.76	
44-5-11	S03468101	1	ネジ	SCREW, SM4.37	
44-5-12	S03657001	1	ナット	NUT, ROUND SM4.37	
44-5-13	S03610001	1	スプリング	SPRING, COMPRESSION	
44-5-14	S03659001	1	プレート	PLATE CAM, ;B-CLAMP	
44-5-15	062680812	2	ネジ	SCREW, PAN SM4.37-40X8	
44-6	017711412	2	ボルト	BOLT, SM4.76X14	
44-7	146354001	2	ワッシャー	WASHER, PLAIN 5	
44-8	014680622	2	セットネジ	SET SCREW, SOCKET (CP) SM4.37	
44-9	S03600001	1	調整プレート	SIZE ADJUSTING PLATE ASSY	
44-10	S03604001	1	ボタン開閉爪	BUTTON OPENER CLAW	
44-11	S03605001	1	ネジ	SCREW, SM6.35	
44-12	150556001	1	ナット	NUT, SM6.35	
44-13	115166001	1	ネジ	SHOULDER SCREW, SM4.37	
44-14	S03606001	1	ストッパーネジ	STOPPER SCREW	
44-15	S03607001	1	スプリング	SPRING	
44-16	S03608001	1	スプリングフック	SPRING HOOK	
44-17	025680232	1	ワッシャー	WASHER, PLAIN M 4.37	
			<ボタンサイズφ10～φ20用>	<FOR BUTTON SIZE φ10～φ20>	
44	S37438109	1	押しウデ	PRESSER ARM ASSY, 917	
44-5	S30016101	1	ボタンクランプ	BUTTON CLAMP ASSY	
44-5-2	S29998001	1	ボタンクランプ	BUTTON CLAMP, L	
44-5-3	S30001001	1	スプリング	SPRING, PLATE ;L	
44-5-4	S29999001	1	ボタンクランプ	BUTTON CLAMP, R	
44-5-5	S30002001	1	スプリング	SPRING, PLATE ;R	
44-5-10	S29954001	1	ボタンクランプ	BUTTON CLAMP ASSY, M	
			<ボタンサイズφ10～φ30用>	<FOR BUTTON SIZE φ10～φ30>	
44	S37436109	1	押しウデ	PRESSER ARM ASSY, 917C	
44-5	S06682101	1	ボタンクランプ	BUTTON CLAMP ASSY, 917C	
44-5-2	S03650001	1	ボタンクランプ	BUTTON CLAMP, LB	
44-5-3	S11079001	1	スプリング	SPRING, PLATE ;L	
44-5-4	S03649001	1	ボタンクランプ	BUTTON CLAMP, RB	
44-5-5	S11080001	1	スプリング	SPRING, PLATE ;R	
44-5-10	S03467001	1	ボタンクランプ	BUTTON CLAMP ASSY, M	

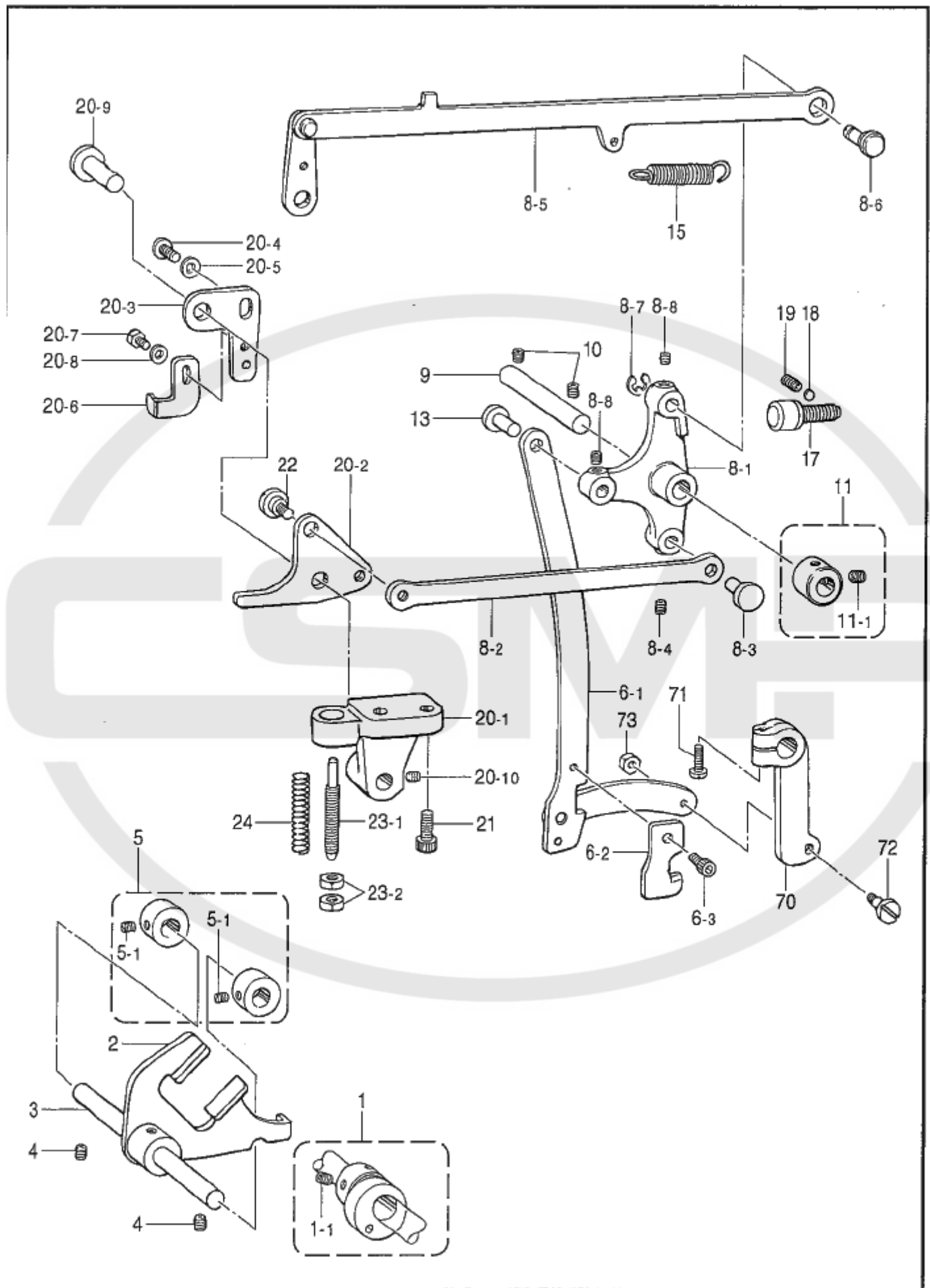

F. 押工上ゲ関係 / Work clamp lifter mechanism

REF.NO	CODE	QTY	ヒンメイ	NAME OF PARTS	RM
1	S03488001	1	サトウカムクミ	DRIVING CAM ASSY	
1-1	014770622	2	アナトメネジ 6.35クホミ	SET SCREW, SOCKET (CP) SM6.35	
2	S03489101	1	ホタンツカミサトウタマタ	BUTTON CLAMP DRIVING FORK	
3	115126001	1	サトウタマタツク	BUTTON CLAMP DRIVING FORK SHAFT	
4	014760622	2	アナトメネジ 5.95	SET SCREW, SOCKET SM5.95	
5	S03490001	2	セツトカラークミ	SET SCREW COLLAR ASSY	
5-1	013710512	4	トメネジ 4.76クホミ	SET SCREW, (CP) SM4.76-32X5	
6	S36629001	1	サトウレンカンクミ	DRIVING CONNECTOR ASSY	
6-1	S36630001	1	レンカンクミ	CONNECTOR ASSY	
6-2	S03496101	1	サトウレンカンツメ	DRIVING ROD CLAW	
6-3	018680822	1	アナホルト 4.37X8	BOLT, SOCKET SM4.37X8	
8	S03500001	1	オサエサトウレハークミ	PRESSER DRIVING LEVER ASSY	
8-1	S03501000	1	オサエサトウレハーク	PRESSER DRIVING LEVER	
8-2	S03502001	1	オサエアケレンケツク	PRESSER LIFTER CONNECT PLATE	
8-3	S03503001	1	オサエアケレンケツク	PRESSER CONNECT STUD	
8-4	014680622	1	アナトメネジ 4.37クホミ	SET SCREW, SOCKET (CP) SM4.37	
8-5	S03504001	1	イトユルメカンクミ	TENSION RELEASE CONNECT ROD ASSY	
8-6	S03508001	1	イトユルメカンチヨウセツク	TENSION RELEASE ADJUST STUD	
8-7	048050342	1	トメE5	RETAINING RING, E5	
8-8	014680622	2	アナトメネジ 4.37クホミ	SET SCREW, SOCKET (CP) SM4.37	
9	S03509001	1	オサエサトウレハーク	PRESSER DRIVING LEVER SHAFT	
10	014760622	2	アナトメネジ 5.95	SET SCREW, SOCKET SM5.95	
11	S03704002	1	セツトカラークミ	SET SCREW COLLAR ASSY	
11-1	014770632	2	アナホルト 6.35-40X6	SET SCREW, SOCKET(CP) SM6.35X6	
13	S03503001	1	オサエアケレンケツク	PRESSER CONNECT STUD	
15	S36633001	1	ヒキハネ	SPRING, EXTENSION	
17	S03512001	2	ストッパークミ	STOPPER SCREW ASSY	
18	100507000	2	アテカネ	PAD METAL	
19	013710712	2	トメネジ 4.76クホミ	SET SCREW, (CP) SM4.76	
20	S03612101	1	オサエアケウテクミ917	PRESSER LIFTER ARM ASSY, 917	
20-1	S03516001	1	オサエアケブラケット	PRESSER LIFTER BRACKET	
20-2	S03517101	1	オサエアケウテ	PRESSER LIFTER ARM	
20-3	S03613001	1	ツメチヨウセツク	CLAW ADJUST PLATE	
20-4	062780812	1	ナハコ 6.35-28X8	SCREW, PAN SM6.35-28X8	
20-5	025060232	1	ヒラサカネチヨウ6	WASHER, PLAIN M 6	
20-6	S03614001	1	ホタンヒラキツメB	BUTTON CLAMP CLAW, B	
20-7	146360002	1	ホルト 4.76X7	BOLT, SM4.76X7	
20-8	146354001	1	サカネ	WASHER, PLAIN 5	
20-9	S03518001	1	オサエアケウテシク	LIFTER ARM STUD	
20-10	014760622	1	アナトメネジ 5.95	SET SCREW, SOCKET SM5.95	
21	018062022	2	アナホルト 6X20	BOLT, SOCKET M6X20	
22	145480101	1	タンネジ 6.35	SHOULDER SCREW, SM6.35	
23	S09146001	1	オサエハネアンナイク	SPRING GUIDE ASSY, B	
23-1	S09147001	1	オサエハネアンナイB	SPRING GUIDE, B	
23-2	110744002	2	ナツト 6.35	NUT, SM6.35	
24	S03521001	1	ホタンツカミオサエオシハネ	SPRING	
70	S37439000	1	ホタンツカミサトウレハーク	BUTTON CLAMP DRIVING LEVER, 7	
71	062761612	1	ナハコ 5.95-28X16	SCREW, PAN SM5.95-28X16	
72	156874001	1	タンネジ 4.76	SHOULDER SCREW, M4.37	
73	110161004	1	ナツト 4.76	NUT, SM4.76	

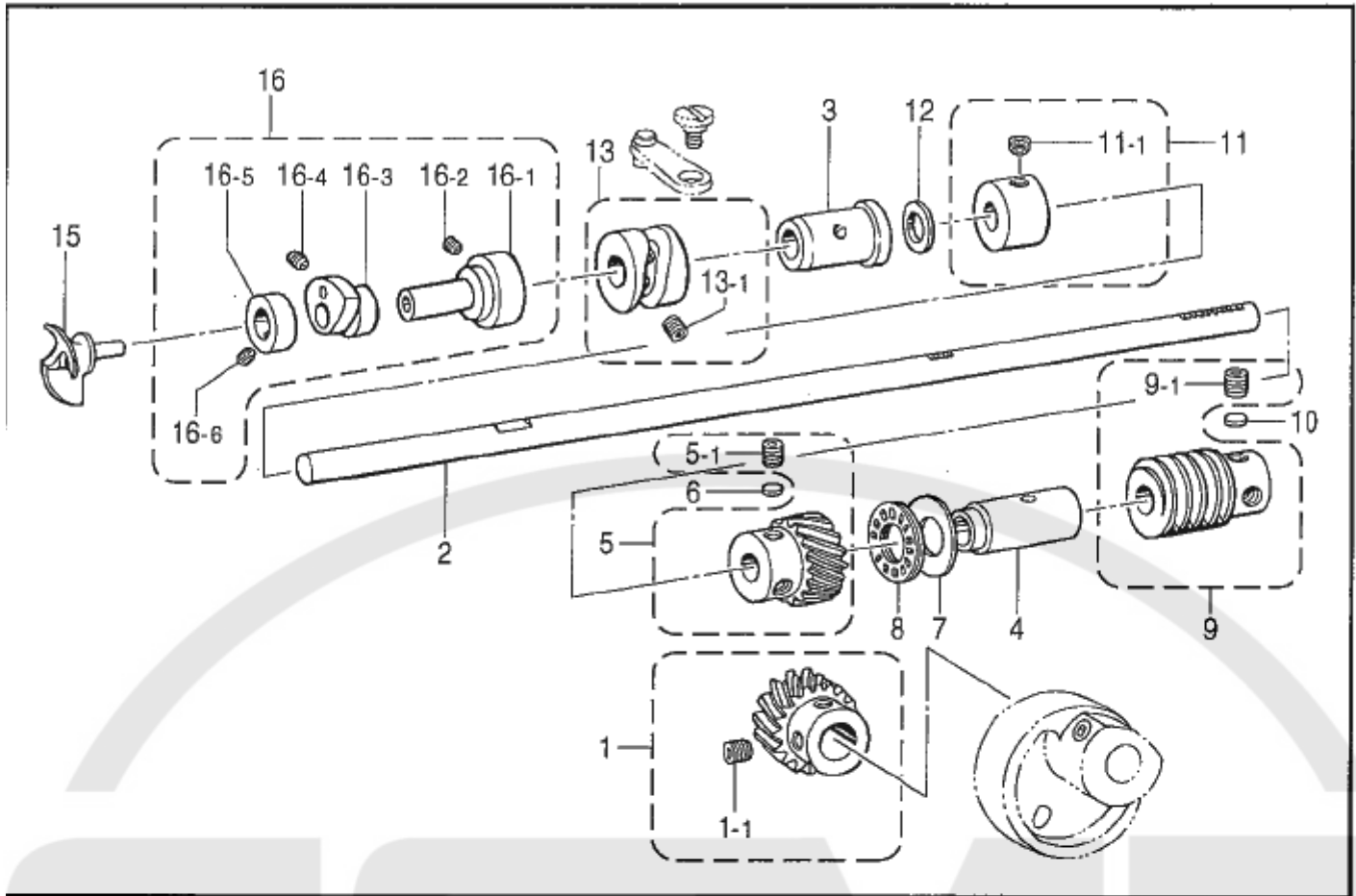

878-917-305

H. 糸サバキ関係 / Loop spreading mechanism

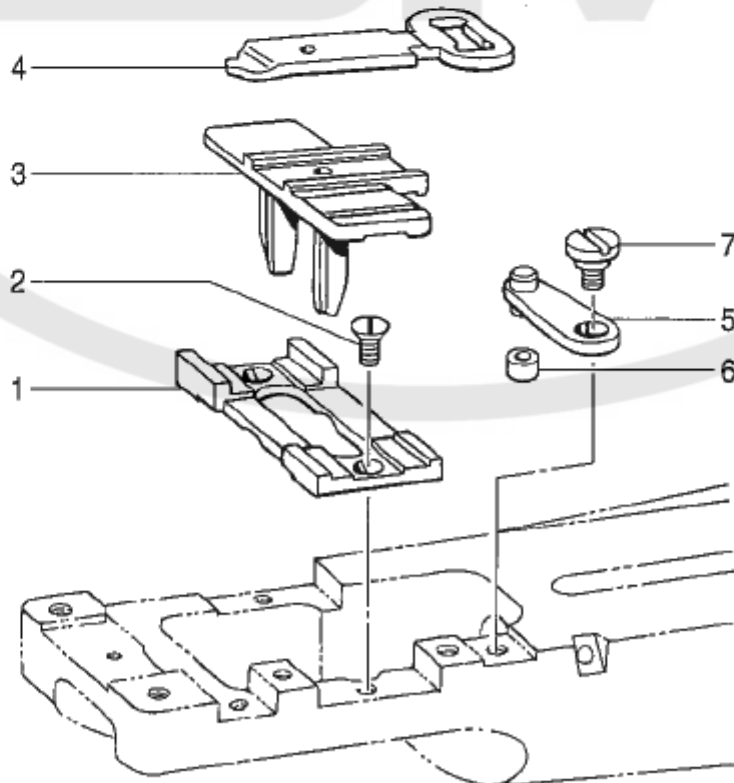

878-917-411

G. 下軸関係 / Lower shaft mechanism

REF.NO	CODE	Q'TY	ヒンメイ	NAME OF PARTS	RM
1	S03522001	1	ヘリカルギヤクミ	HELICAL GEAR ASSY	
1-1	014770622	2	アトメネシ ^{6.35} ホ ⁶ ミ	SET SCREW, SOCKET (CP) SM6.35	
2	S03523101	1	シタシク	LOWER SHAFT	
3	S03524000	1	シタシクメタルF	LOWER SHAFT BUSH, F	
4	S03525000	1	シタシクメタルB	LOWER SHAFT BUSH, B	
5	S03526001	1	シタシクヘリカルギヤクミ	LOWER SHAFT GEAR ASSY	
5-1	014770622	2	アトメネシ ^{6.35} ホ ⁶ ミ	SET SCREW, SOCKET (CP) SM6.35	
6	147151000	1	トメサ ^ガ ネ	WASHER	
7	S10668001	1	サ ^ガ ネ	WASHER	
8	115008000	1	タマシクウケ	BALL BEARING	
9	*	1	ウオームクミ	WORM ASSY	
9-1	014770622	3	アトメネシ ^{6.35} ホ ⁶ ミ	SET SCREW, SOCKET (CP) SM6.35	
10	147151000	1	トメサ ^ガ ネ	WASHER	
11	183943001	1	セツトカラークミ	SET SCREW COLLAR ASSY	
11-1	S39973001	2	アナクホ ^{635-40X5}	SET SCREW, SOCKET SM6.35-40X5	
12	107153001	1	サ ^ガ ネ	WASHER	
13	S03533001	1	イトサハ ^{キミツ} カムクミ	GROOVED CAM ASSY	
13-1	110124001	2	トメネシ ^{5.56}	SET SCREW, M5.56	
15	S03536001	1	ル ^ハ ー	ROTARY LOOPER	
16	S36699001	1	テ ^ル タカムクミ	TRIANGULAR CAM ASSY	
16-1	115066000	1	ル ^ハ トリツケシク	LOOPER SETTING SHAFT	
16-2	013750512	2	トメネシ ^{5.56} ホ ⁶ ミ	SET SCREW, (CP) SM5.56	
16-3	115067001	1	イトサハ ^{キテ} ルタカム	THREAD HANDLER TRIANGULAR CAM	
16-4	014680422	2	アトメネシ ^{4.37} ホ ⁶ ミ	SET SCREW, SOCKET (CP) SM4.37	
16-5	115068101	1	セツトカラ	SET SCREW COLLAR	
16-6	151602001	1	トメネシ ^{4.37}	SET SCREW, SM4.37	

878-917-305

H. 糸サバキ関係 / Loop spreading mechanism

REF.NO	CODE	Q'TY	ヒンメイ	NAME OF PARTS	RM
1	S03567001	1	イトサハ ^{キタ} イ	THREAD HANDLER BRACKET	
2	S01696001	2	サラネシ ^{3.57X6}	SCREW, FLAT SM3.57X6	
3	S36624001	1	イトサハ ^{キアン} ナイタ	GUIDE PLATE, L/TR-FINGER	
4	S36625001	1	イトサハ ^キ	LOWER THREAD FINGER	
5	115073001	1	イトサハ ^{キリンク} クミ	THREAD HANDLER LINK ASSY	
6	115076001	1	イトサハ ^{キリンク} コロ	ROLLER	
7	115077001	1	タンネシ ^{4.76}	SHOULDER SCREW, M4.76	

878-917-411

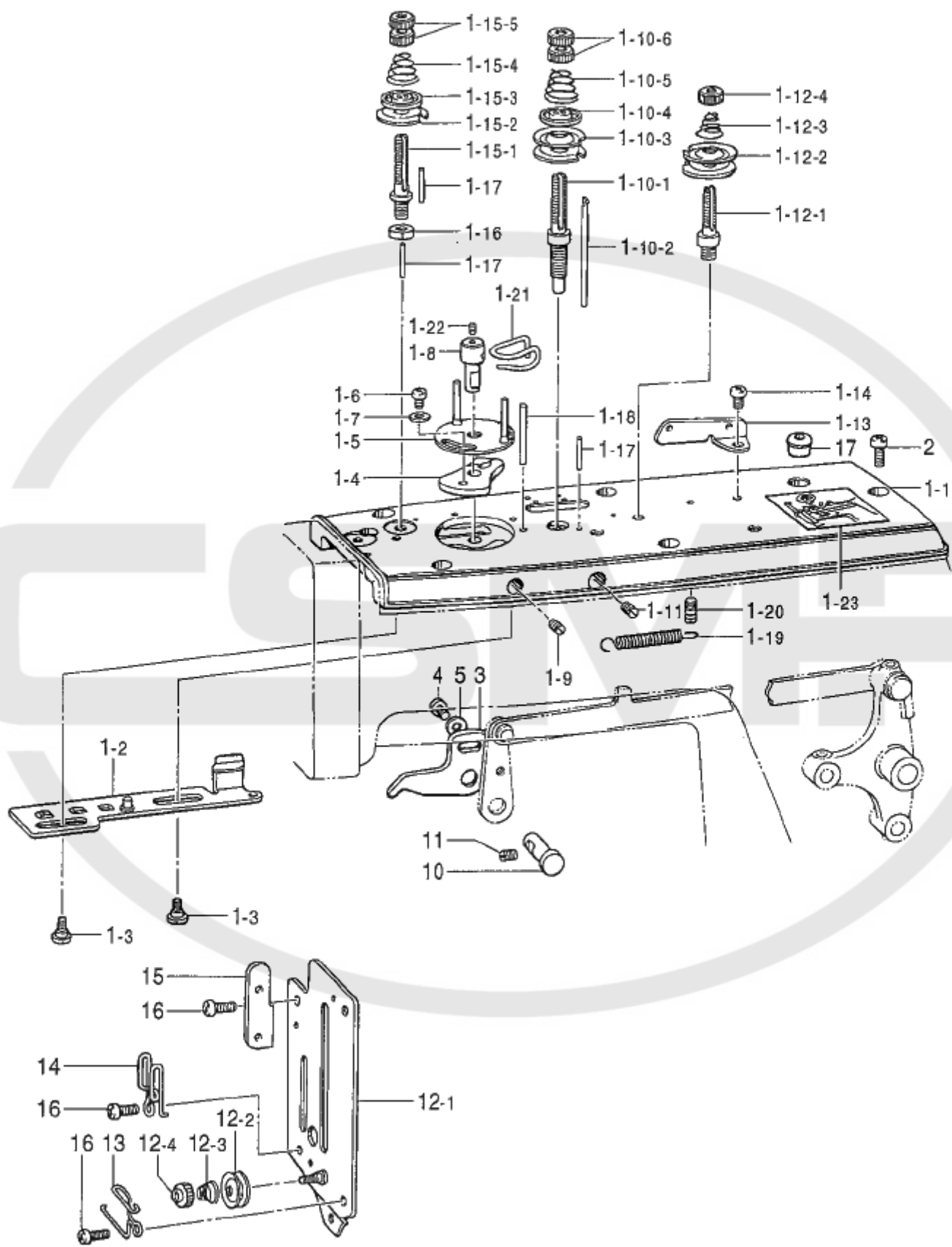

J. 糸通シ関係 / Threading mechanism

REF.NO	CODE	Q'TY	ヒンメイ	NAME OF PARTS	RM
1	S03615109	1	ウツタクミ917	TOP COVER ASSY, 917	
1-1	S03538109	1	ウツタ	TOP COVER	
1-2	S03616101	1	スライダークミB	SLIDER ASSY, B	
1-3	S03540001	2	タンネシ 4.76	SHOULDER SCREW, M4.76	
1-4	S03541001	1	ローターベース	ROTOR BASE	
1-5	S03542001	1	ロータークミ	ROTOR ASSY	
1-6	062710612	1	ナハコ476-32X6	SCREW, PAN SM4.76-32X6	
1-7	146354001	1	ザガネ	WASHER, PLAIN 5	
1-8	S03543101	1	ローターシフト	ROTOR SHAFT	
1-9	013710712	1	トメネシ 4.76クミ	SET SCREW, (CP) SM4.76	
1-10	S03544101	1	フキトチヨウシホクウミ	SUB TENSION STUD ASSY	
1-10-1	S03545001	1	フキトチヨウシホクウ	SUB TENSION STUD	
1-10-2	S03546001	1	ユルメピン	PIN	
1-10-3	115187101	2	イトチヨウシハラ	TENSION DISC	
1-10-4	159805001	1	イトチヨウシハラオサエ	TENSION DISC PRESSER	
1-10-5	148924101	1	イトチヨウシハネ	TENSION SPRING	
1-10-6	100136001	2	イトチヨウシナツト	TENSION NUT	
1-11	013710712	1	トメネシ 4.76クミ	SET SCREW, (CP) SM4.76	
1-12	S06057001	1	シユイトチヨウシホクウミ	MAIN TENSION STUD ASSY	
1-12-1	115186001	1	シユイトチヨウシホクウ	TENSION STUD, MAIN	
1-12-2	115187101	2	イトチヨウシハラ	TENSION DISC	
1-12-3	115188002	1	シユイトチヨウシハネ	TENSION SPRING	
1-12-4	100136001	1	イトチヨウシナツト	TENSION NUT	
1-13	115183101	1	イトカケ	THREAD RETAINER	
1-14	062710612	1	ナハコ476-32X6	SCREW, PAN SM4.76-32X6	
1-15	S03549001	1	イトオサエチヨウシホクウミ	THREAD PRESSER TENSION STUD ASSY	
1-15-1	S03550001	1	イトオサエチヨウシホクウ	THREAD PRESSER TENSION STUD	
1-15-2	115187101	1	イトチヨウシハラ	TENSION DISC	
1-15-3	159805001	1	イトチヨウシハラオサエ	TENSION DISC PRESSER	
1-15-4	S06432001	1	イトチヨウシハネ	TENSION SPRING	
1-15-5	100136001	2	イトチヨウシナツト	TENSION NUT	
1-16	150556001	1	ナツト6.35	NUT, SM6.35	
1-17	S03551001	4	ユルメピン	PIN	
1-18	S03556001	1	ピン3	PIN 3	
1-19	S03557001	1	スライダ-ヒキハネ	SPRING, EXTENSION	
1-20	S03558001	1	ハネカケ	SPRING HOOK	
1-21	S06253201	1	ローターシフトカケ	THREAD GUIDE	
1-22	014680622	1	アタメネシ 4.37クミ	SET SCREW, SOCKET (CP) SM4.37	
1-23	S16253001	1	イトオシセツマイイタ	THREADING DIAGRAM	
2	062711012	5	ナハコ476-32X10	SCREW, PAN SM4.76-32X10	
3	S03617001	1	イトリレバ-	THREAD TAKE-UD LEVER	
4	062711012	1	ナハコ476-32X10	SCREW, PAN SM4.76-32X10	
5	146354001	1	ザガネ	WASHER, PLAIN 5	
10	S03560001	1	イトリレバ-シフト	THREAD TAKE-UP LEVER SHAFT	
11	013710712	1	トメネシ 4.76クミ	SET SCREW, (CP) SM4.76	
12	S03561201	1	メンイタクミ	FACE PLATE ASSY	
12-1	S03377101	1	メンイタクミコ	FACE PLATE SMALL ASSY	
12-2	144504001	2	イトアンナイサラ	THREAD GUIDEDISC	
12-3	144505000	1	イトアンナイハネ	SPRING	
12-4	155510001	1	イトチヨウシナツト	TENSION NUT	
13	S03564001	1	サブテンションイトアンナイ	SUB TENSION THREAD GUIDE	
14	S03565001	1	メンイタイトアンナイ	FACE PLATE THREAD GUIDE	
15	S03566001	1	メンイタイトカケ	FACE PLATE THREAD HOOK	
16	062711012	4	ナハコ476-32X10	SCREW, PAN SM4.76-32X10	
17	112758001	1	ヘッドオイルフタ	OIL CAP	

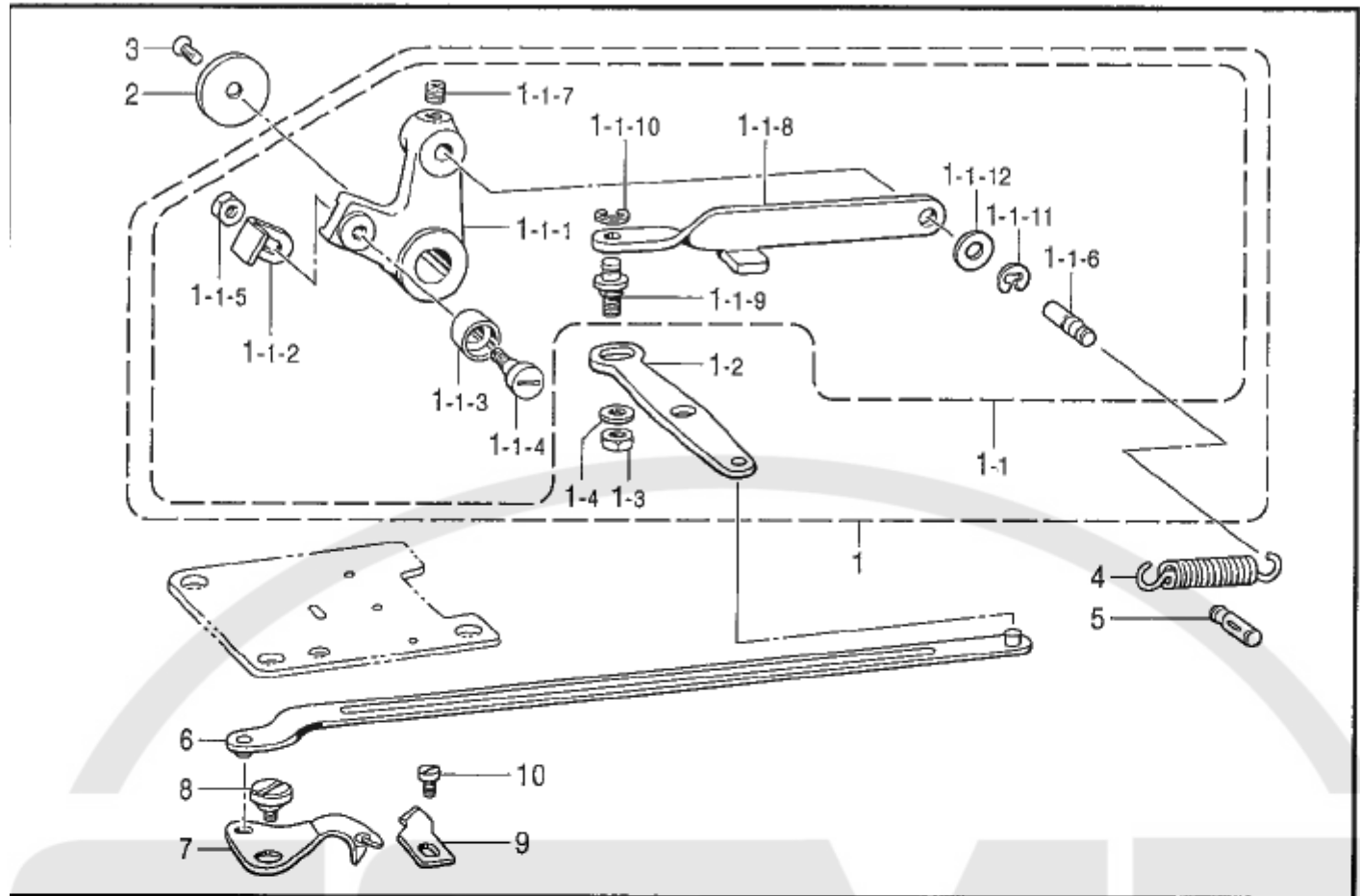

1 . オプションパーツ / Option parts

878-917-403

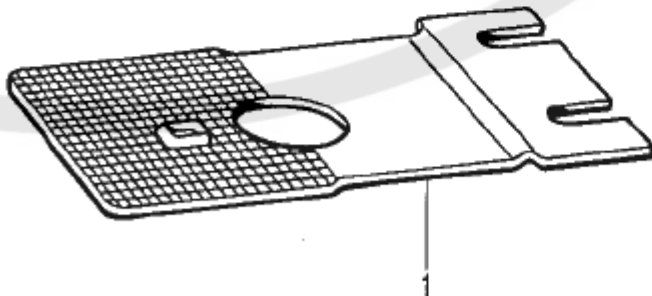
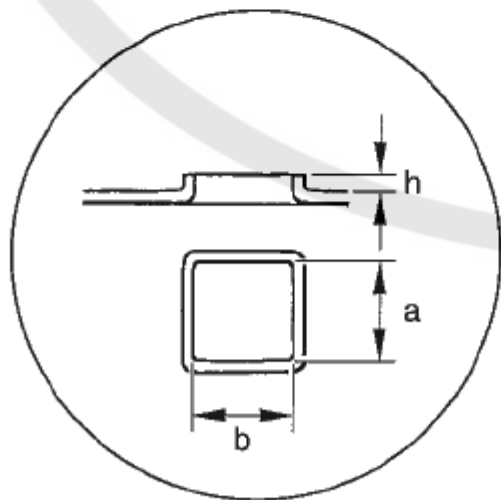

878-917-940

K. 糸切り関係 / Thread trimmer mechanism

REF.NO	CODE	Q'TY	ヒンメイ	NAME OF PARTS	RM
1	S37369001	1	イトキリハゝーギミ	THREAD TRIMMER LEVER ASSY	
1-1	SA1086001	1	イトキリハゝーギミコ	THREAD TRIMMER LEVER SUB ASSY	
1-1-1	S36617001	1	イトキリハゝー	THREAD TRIMMER LEVER	
1-1-2	S03406101	1	ツメ	CLAW	
1-1-3	S03407001	1	コロ	ROLLER	
1-1-4	S03408001	1	コロタゝンネジ	SHOULDER SCREW	
1-1-5	110161004	1	ナツト4.76	NUT, SM4.76	
1-1-6	S34278001	1	ハゝネカケシヅク	SPRING HANGER SHAFT	
1-1-7	014760622	1	アツトメネジ 5.95	SET SCREW, SOCKET SM5.95	
1-1-8	S03621001	1	イトキリレンケツカン	CONNECTING BAR	
1-1-9	S03623001	1	レンケツカンシヅク	CONNECTING BAR SHAFT	
1-1-10	048050342	1	トマツE5	RETAINING RING, E5	
1-1-11	048040342	1	トマツE4	RETAINING RING, E4	
1-1-12	155559001	1	ヒラサゝガネ	WASHER, PLAIN	
1-2	S03622101	1	イトキリレンケツレハゝー	CONNECTING LEVER	
1-3	150553001	1	ナツト5.95	NUT, SM5.95	
1-4	025060232	1	ヒラサゝガネチヨウ6	WASHER, PLAIN M 6	
2	151932001	1	シヅクウケフタ	BEARING COVER	
3	107231002	1	サラネシ 4.76	SCREW, FLAT SM4.76	
4	S03624001	1	イトキリハゝーハゝネ	SPRING	
5	S34298001	1	ミゾヅキピン	DOWEL PIN	
6	S03626001	1	イトキリレンカンギミ	THREAD TRIMMER CONNECTING ROD ASSY	
7	S03627001	1	イトウハ	MOVABLE KNIFE	
8	S03628001	1	イトウハタゝンネジ	MOVABLE KNIFE SHOULDER SCREW	
9	S03629001	1	コトハ	FIXED KNIFE	
10	106629002	1	シメネジ 4.37	SCREW, SM4.37	

878-917-403

L1. オプションパーツ / Option parts

REF.NO	CODE	Q'TY	ヒンメイ	NAME OF PARTS	RM
1	S03476101	1	オクリイタA	FEED PLATE, A	
1	S03630101	1	オクリイタB	FEED PLATE, B	
1	115085001	1	オクリイタC	FEED PLATE, C	
1	S03632101	1	オクリイタD	FEED PLATE, D	
1	S16121101	1	オクリイタE	FEED PLATE, E	

878-917-940

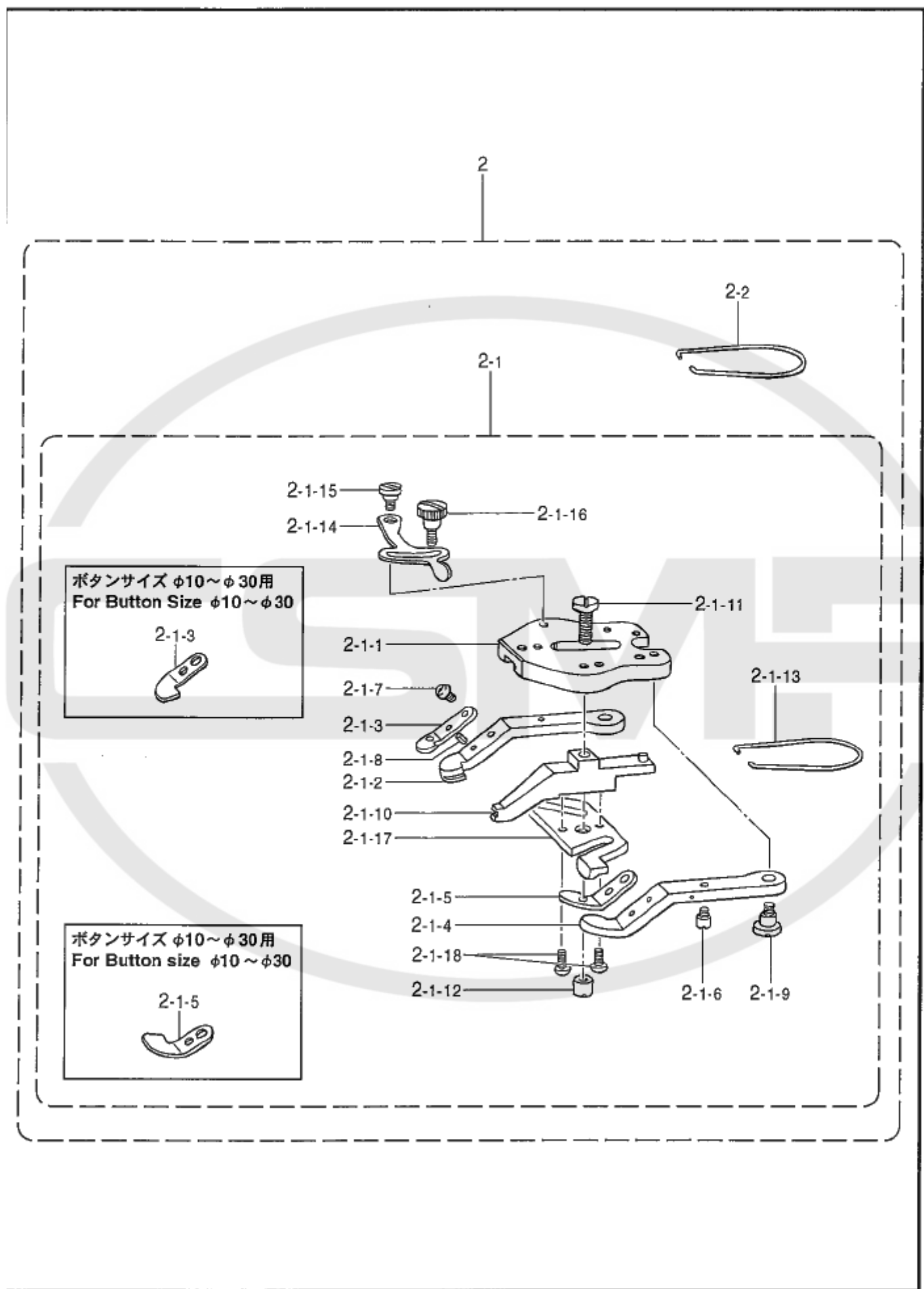

L2. オプションパーツ / Option parts

REF.NO	CODE	QTY	ヒンメイ	NAME OF PARTS	RM
			<ボタンサイズ φ10～φ20用>	<FOR BUTTON SIZE φ10～φ20>	
2	S03701001	1	ボタンセットA	BUTTON CLAMP SET A	
2-1	S30015101	1	ボタンミクミ	BUTTON CLAMP ASSY	
2-1-1	S03464101	1	ボタンミタイ	BUTTON CLAMP BRACKET	
2-1-2	S29998001	1	ボタンミL	BUTTON CLAMP, L	
2-1-3	S30001001	1	ボタンミLイタハネ	SPRING, PLATE ;L	
2-1-4	S29999001	1	ボタンミR	BUTTON CLAMP, R	
2-1-5	S30002001	1	ボタンミRイタハネ	SPRING, PLATE ;R	
2-1-6	115156001	2	ボタンミアンナイピン	GUIDE PIN	
2-1-7	062680512	2	ナット437-40X5	SCREW, PAN SM4.37-40X5	
2-1-8	047250642	2	スプリングピンAW2.5	PIN, SPRING ROLL AW2.5	
2-1-9	115158001	2	タンネジ 4.76	SHOULDER SCREW, SM4.76	
2-1-10	S29954001	1	ボタンミMクミ	BUTTON CLAMP ASSY, M	
2-1-11	S03468101	1	シメネジ 4.37	SCREW, SM4.37	
2-1-12	S03657001	1	マルナット4.37	NUT, ROUND SM4.37	
2-1-13	115163001	1	ボタンミイタハネ	SPRING, PLATE	
2-1-14	115164101	1	ボタンミミチヨウセツイタ	ADJUSTING PLATE, ;B-CLAMP	
2-1-15	115165001	1	タンネジ 4.37	SHOULDER SCREW, SM4.37	
2-1-16	115166001	1	タンネジ 4.37	SHOULDER SCREW, SM4.37	
2-1-17	S03659001	1	ボタンミイタカム	PLATE CAM, ;B-CLAMP	
2-1-18	062680812	2	ナット437-40X8	SCREW, PAN SM4.37-40X8	
2-2	S03610001	1	ボタンミモトシハネ	SPRING, COMPRESSION	
			<ボタンサイズ φ10～φ30用>	<FOR BUTTON SIZE φ10～φ30>	
2	S03633001	1	ボタンセットB	BUTTON CLAMP SET, B	
2-1	S03634101	1	ボタンミクミB	BUTTON CLAMP ASSY, B	
2-1-1	S03464101	1	ボタンミタイ	BUTTON CLAMP BRACKET	
2-1-2	S03650001	1	ボタンミLB	BUTTON CLAMP, LB	
2-1-3	S11079001	1	ボタンミLイタハネ	SPRING, PLATE ;L	
2-1-4	S03649001	1	ボタンミRB	BUTTON CLAMP, RB	
2-1-5	S11080001	1	ボタンミRイタハネ	SPRING, PLATE ;R	
2-1-6	115156001	2	ボタンミアンナイピン	GUIDE PIN	
2-1-7	062680512	2	ナット437-40X5	SCREW, PAN SM4.37-40X5	
2-1-8	047250642	2	スプリングピンAW2.5	PIN, SPRING ROLL AW2.5	
2-1-9	115158001	2	タンネジ 4.76	SHOULDER SCREW, SM4.76	
2-1-10	S03467001	1	ボタンミMクミ	BUTTON CLAMP ASSY, M	
2-1-11	S03468101	1	シメネジ 4.37	SCREW, SM4.37	
2-1-12	S03657001	1	マルナット4.37	NUT, ROUND SM4.37	
2-1-13	115163001	1	ボタンミイタハネ	SPRING, PLATE	
2-1-14	115164101	1	ボタンミミチヨウセツイタ	ADJUSTING PLATE, ;B-CLAMP	
2-1-15	115165001	1	タンネジ 4.37	SHOULDER SCREW, SM4.37	
2-1-16	115166001	1	タンネジ 4.37	SHOULDER SCREW, SM4.37	
2-1-17	S03659001	1	ボタンミイタカム	PLATE CAM, ;B-CLAMP	
2-1-18	062680812	2	ナット437-40X8	SCREW, PAN SM4.37-40X8	
2-2	S03610001	1	ボタンミモトシハネ	SPRING, COMPRESSION	

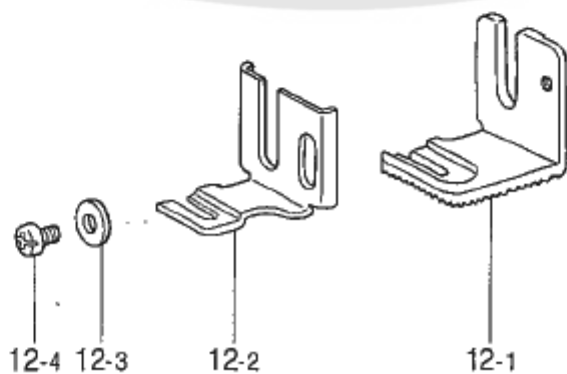
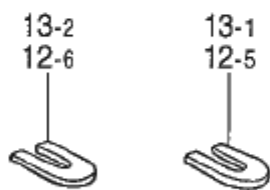
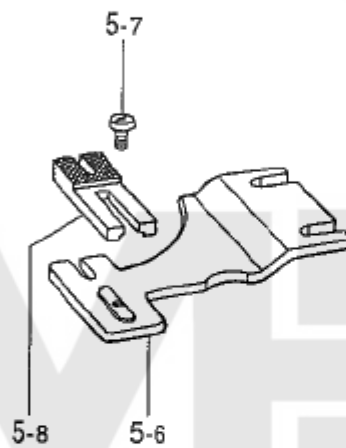
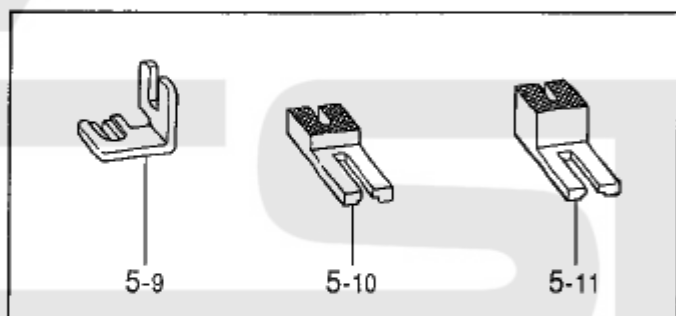
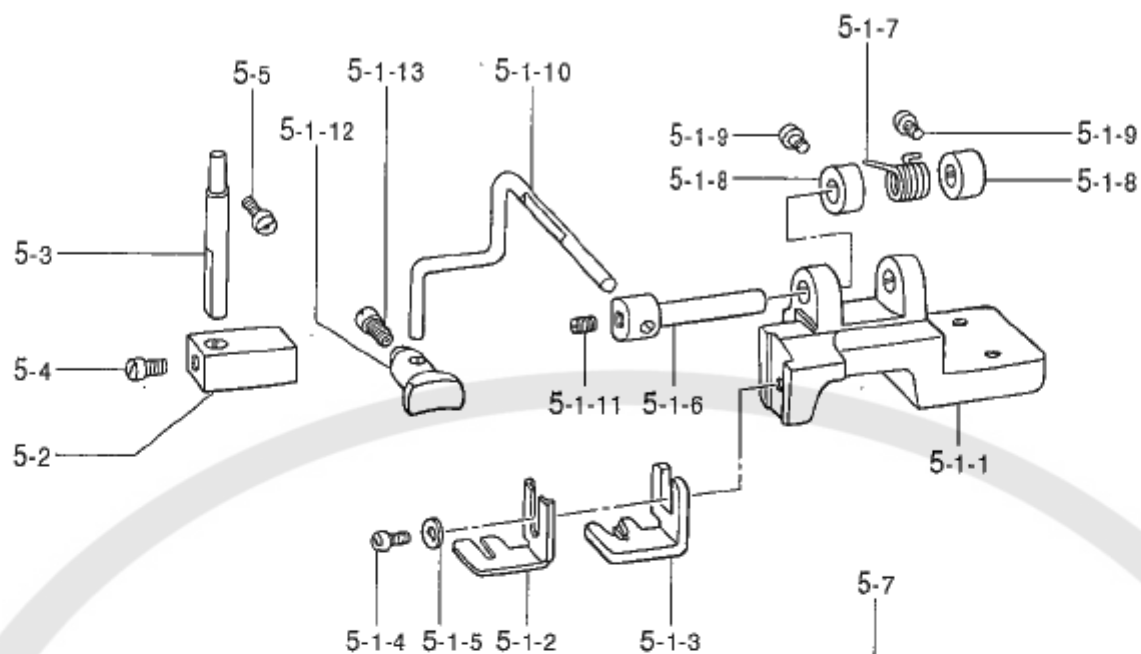

L3. オプションパーツ / Option parts

REF.NO	CODE	QTY	ヒンメイ	NAME OF PARTS	RM
5	142570109	1	シヤンクアツツチメントクミ	SHANK BUTTON ATTACHMENT	
5-1	142689309	1	シヤンクホタンツマミタイクミ	SHANK BUTTON CLAMP BRAC. ASSY	
5-1-1	154684009	1	シヤンクホタンツマミタイ	SHANK BUTTON CLAMP BRACKET	
5-1-2	142677101	1	ホタンツマミA	BUTTON CLAMP, A	
5-1-3	142678101	1	ホタンツマミB	BUTTON CLAMP, B	
5-1-4	062670812	1	ナハコ3.57-40X8	SCREW, PAN SM3.57-40X8	
5-1-5	102707003	1	サカネ	WASHER	
5-1-6	142681001	1	ホタンオサエシク	BUTTON CLAMP STUD	
5-1-7	154685001	1	ホタンオサエシクハネ	SPRING	
5-1-8	142706001	2	セツトカラ	SET SCREW COLLAR	
5-1-9	062670712	2	ナハコ357-40X7	SCREW, PAN SM3.57-40X7	
5-1-10	154686001	1	ホタンオサエウテ	BUTTON CLAMP ARM	
5-1-11	013719412	1	トメネシ4.76クホミ	SET SCREW, (CP) SM4.76	
5-1-12	142680001	1	ホタンオサエ	BUTTON CLAMP	
5-1-13	120990001	1	アタマツキトメネシ4.37	SET SCREW, (CP) SM4.37-40X8	
5-2	142683101	1	ホタンオサエウテアケ	BUTTON PRESSER ARM LIFTER	
5-3	142684001	1	オサエウテアケシク	BUTTON PRESSER ARM LIFTER BAR	
5-4	120990001	1	アタマツキトメネシ4.37	SET SCREW, (CP) SM4.37-40X8	
5-5	062711012	1	ナハコ476-32X10	SCREW, PAN SM4.76-32X10	
5-6	156336101	1	シヤンクホタンオクリイタ	FEED PLATE, ;S-BUTTON	
5-7	060670512	1	ハイント357-40X5	SCREW, BIND SM3.57-40X5	
5-8	142686101	1	ヌノウケダイス	CLOTH RECEIVER, S	
5-9	S03641101	1	ホタンカミD	BOTTON CLAMP D	
5-10	142687101	1	ヌノウケダイM	CLOTH RECEIVER, M	
5-11	142688001	1	ヌノウケダイL	CLOTH RECEIVER (LARGE)	
12	S10654001	1	シヤンクゲージキット	SHANK GAUGE KIT	
12-1	S10560001	1	ホタンツマミE	BUTTON CLAMP (E)	
12-2	S10651001	1	ホタンツマミF	BUTTON CLAMP (F)	
12-3	105161003	1	サカネ	WASHER	
12-4	S39086001	1	ナハコ357-40X3.5	SCREW, PAN SM3.57-40X3.5	
12-5	S10652000	5	ホタンガイド1.5	BUTTON GUIDE (1.5)	
12-6	S10653000	5	ホタンガイド1.0	BUTTON GUIDE (1.0)	
13	S10655001	1	ホタンガイドセット	BUTTON GUIDE SET	
13-1	S10652000	10	ホタンガイド1.5	BUTTON GUIDE (1.5)	
13-2	S10653000	10	ホタンガイド1.0	BUTTON GUIDE (1.0)	

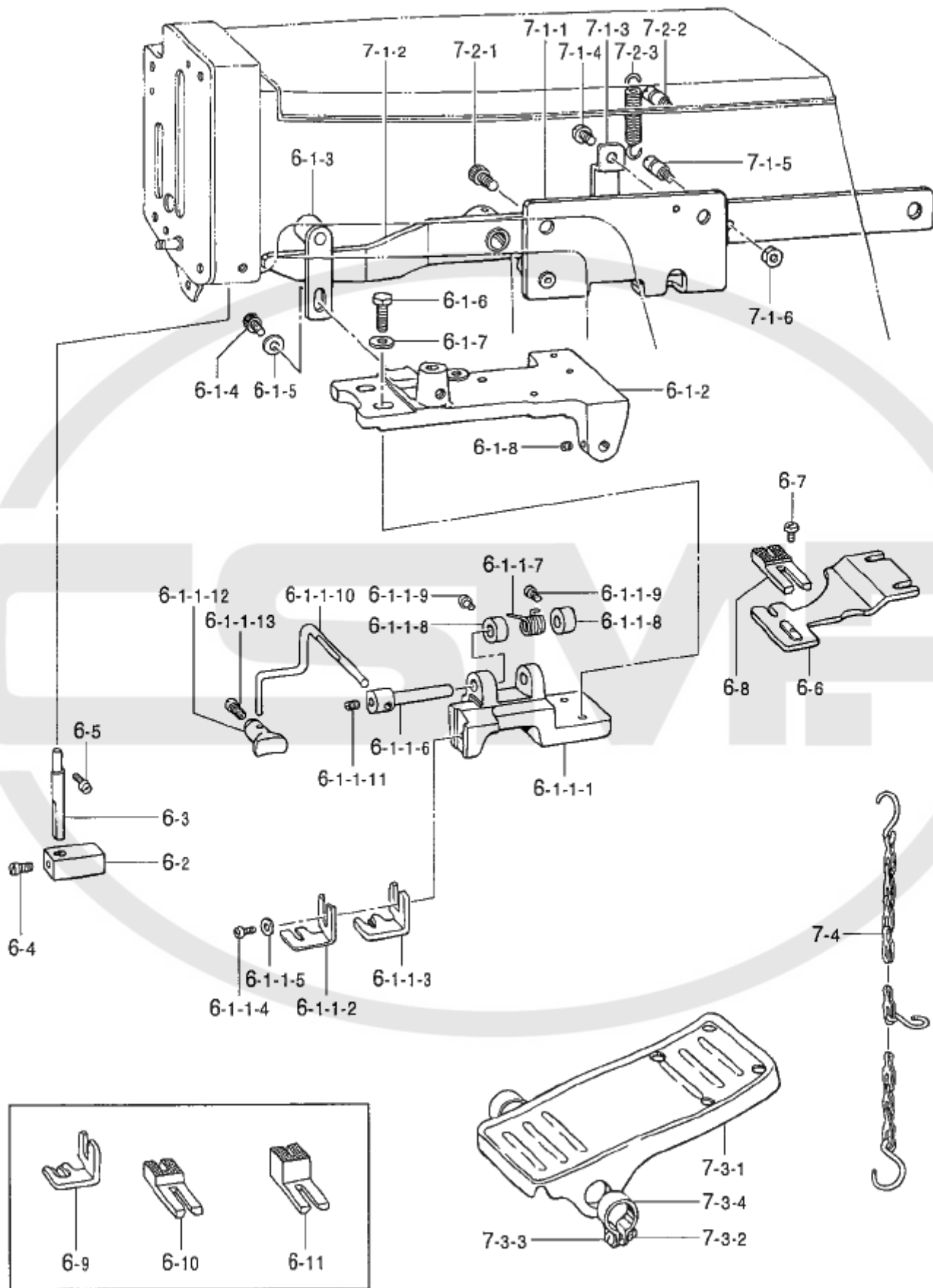

L4. オプションパーツ / Option parts

REF.NO	CODE	QTY	ヒンメイ	NAME OF PARTS	RM
6	S39822109	1	シヤンクソウチセツト	SHANK DEVICE SET	
6-1	S39823109	1	シヤンクホ`タンツマミクミ	SHANK BUTTON CLAMP ASSY	
6-1-1	142689309	1	シヤンクホ`タンツマミタイクミ	SHANK BUTTON CLAMP BRAC. ASSY	
6-1-1-1	154684009	1	シヤンクホ`タンツマミタイ	SHANK BUTTON CLAMP BRACKET	
6-1-1-2	142677101	1	ホ`タンツマミA	BUTTON CLAMP, A	
6-1-1-3	142678101	1	ホ`タンツマミB	BUTTON CLAMP, B	
6-1-1-4	062670812	1	ナ`コ3.57-40X8	SCREW, PAN SM3.57-40X8	
6-1-1-5	102707003	1	ワ`カ`ネ	WASHER	
6-1-1-6	142681001	1	ホ`タンオサエシ`ク	BUTTON CLAMP STUD	
6-1-1-7	154685001	1	ホ`タンオサエシ`クハ`ネ	SPRING	
6-1-1-8	142706001	2	セツトカラ-	SET SCREW COLLAR	
6-1-1-9	062670712	2	ナ`コ357-40X7	SCREW, PAN SM3.57-40X7	
6-1-1-10	154686001	1	ホ`タンオサエシ`ク	BUTTON CLAMP ARM	
6-1-1-11	013719412	1	トメネシ`4.76クホ`ミ	SET SCREW, (CP) SM4.76	
6-1-1-12	142680001	1	ホ`タンオサエ	BUTTON CLAMP	
6-1-1-13	120990001	1	アタマツキトメネシ`4.37	SET SCREW, (CP) SM4.37-40X8	
6-1-2	S37352009	1	オサエシ`ク	PRESSER ARM	
6-1-3	S03459051	1	オサエシ`クセツツイタクミ	PRESSER ADJUSTING PLATE ASSY	
6-1-4	018061022	1	アナホ`ルト6X10	BOLT, SOCKET M6X10	
6-1-5	S03695001	1	ワ`カ`ネ6	WASHER, PLAIN 6	
6-1-6	017711412	2	ホ`ルト4.76X14	BOLT, SM4.76X14	
6-1-7	146354001	2	ワ`カ`ネ	WASHER, PLAIN 5	
6-1-8	014680622	2	アトメネシ`4.37クホ`ミ	SET SCREW, SOCKET (CP) SM4.37	
6-2	142683101	1	ホ`タンオサエシ`ク	BUTTON PRESSER ARM LIFTER	
6-3	142684001	1	オサエシ`ク	BUTTON PRESSER ARM LIFTER BAR	
6-4	120990001	1	アタマツキトメネシ`4.37	SET SCREW, (CP) SM4.37-40X8	
6-5	062711012	1	ナ`コ476-32X10	SCREW, PAN SM4.76-32X10	
6-6	156336101	1	シヤンクホ`タンオクリタ	FEED PLATE, ;S-BUTTON	
6-7	060670512	1	ハ`イント`357-40X5	SCREW, BIND SM3.57-40X5	
6-8	142686101	1	ヌウケダ`IS	CLOTH RECEIVER, S	
6-9	S03641101	1	ホ`タンカミD	BOTTOM CLAMP D	
6-10	142687101	1	ヌウケダ`IM	CLOTH RECEIVER, M	
6-11	142688001	1	ヌウケダ`IL	CLOTH RECEIVER (LARGE)	
7	S03655002	1	メカ2ハ`セツト	MECHANICAL TWO-PEDAL SET	
7-1	S03714001	1	オサエシ`クレバ`-クミ	LIFTER LEVER ASSY, ;P-BAR	
7-1-1	S03705001	1	ハ`-スフ`レート	BASE PLATE	
7-1-2	S03706001	1	オサエシ`クレバ`-	LIFTER LEVER, ;P-BAR	
7-1-3	S03707001	1	ガイト`フ`レート	GUIDE PLATE	
7-1-4	062710612	1	ナ`コ476-32X6	SCREW, PAN SM4.76-32X6	
7-1-5	S03625001	1	ハ`ネカク	SPRING HOOK	
7-1-6	110161004	1	ナツト4.76	NUT, SM4.76	
7-2	S37805001	1	オサエシ`クハ`ネ	PRESSER LIFTER SPRING ASSY	
7-2-1	018061422	2	アナホ`ルト6X14	BOLT, SOCKET M6X14	
7-2-2	S03625001	1	ハ`ネカク	SPRING HOOK	
7-2-3	S03624001	1	イトキリレバ`-ハ`ネ	SPRING	
7-3	116185209	1	ハ`タルクミ	PEDAL ASSY	
7-3-1	117437109	1	オサエシ`クフミイタ	FOOT LIFTER PEDAL	
7-3-2	021400106	2	ナツト1`24	NUT, 1 M4	
7-3-3	062401416	2	ナ`コ4X14	SCREW, PAN M4X14	
7-3-4	116016001	2	ハ`タルトメ	PEDAL STOPPER	
7-4	142656001	1	クサリクミ	CHAIN ASSY	

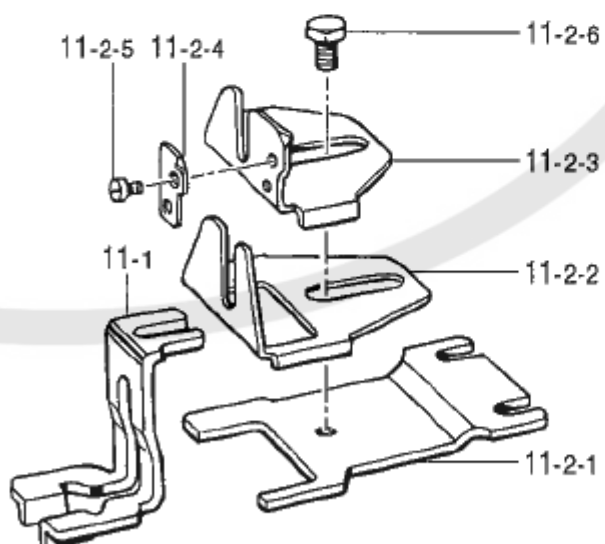
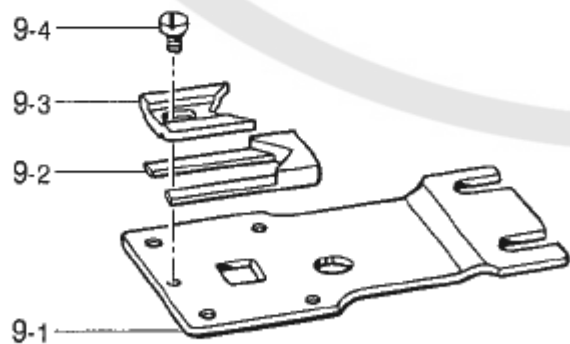
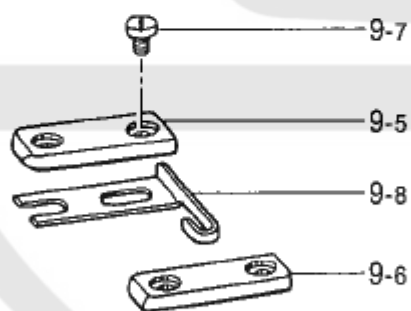
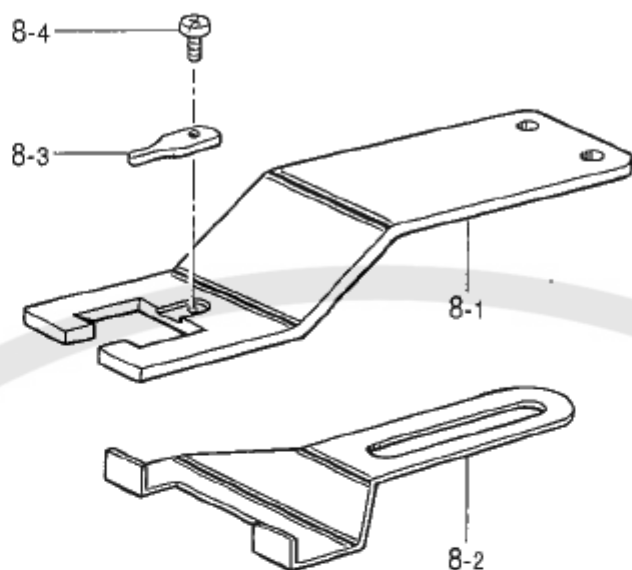

L5. オプションパーツ / Option parts

REF.NO	CODE	Q'TY	ヒンメイ	NAME OF PARTS	RM
8	S03692001	1	ラベル付アタッチメントクミ	LABEL ATTACHMENT	
8-1	S09144001	1	ラベル付ヨウクランプ	LABEL CLAMP	
8-2	S09143001	1	ストッパ	STOPPER	
8-3	S09145001	1	クランプバネ	CLAMP SPRING	
8-4	S01295001	2	シメネジ 2.38X3.5	SCREW, SM2.38X3.5	
9	S03693001	1	チカラボタンクミ	STAY BUTTON ATTACHMENT (S)	
9-1	S09482001	1	チカラボタンオクリイタ	STAY BUTTON FEED PLATE	
9-2	S09483001	1	ボタンウケタD	BUTTON RECEIVER (D)	
9-3	S09484001	1	ボタンウケタU	BUTTON RECEIVER (U)	
9-4	S09494001	1	シメネジ 3.18-44X3.4	SCREW, SM3.18-44X3.4	
9-5	S09485001	1	ウケタイアンナIL	RECEIVER GUIDE (L)	
9-6	S09486001	1	ウケタイアンナIR	RECEIVER GUIDE (R)	
9-7	S09493001	4	シメネジ 3.18-44X4	SCREW, SM3.18-44X4	
9-8	S09487001	1	ウケタイササバネ	RECEIVER SUPPORT SPRING	
11	150416001	1	ネキアタッチメントクミ	BUTTON ROOT WRAPPING ATTACHMENT	
11-1	S09488001	1	ウカシゲージ	LIFTING GAUGE	
11-2	S09564001	1	ネキゲージクミ	WRAPPING GAUGE ASSY	
11-2-1	S09489001	1	ネキオクリイタ	ROOT WRAPPING BUTTON FEED PLATE	
11-2-2	S09490001	1	ネキボタンウケA	BUTTON ROOT WRAPPING RECEIVER (A)	
11-2-3	S09491001	1	ネキボタンウケB	BUTTON ROOT WRAPPING RECEIVER (B)	
11-2-4	S09492001	1	イトツカミ	THREAD NIPPER	
11-2-5	S09496001	2	シメネジ 2.38-56X1.9	SCREW, SM2.38-56X1.9	
11-2-6	S09495001	1	ボルト 4.37-40X4.5	BOLT, SM4.37-40X4.5	

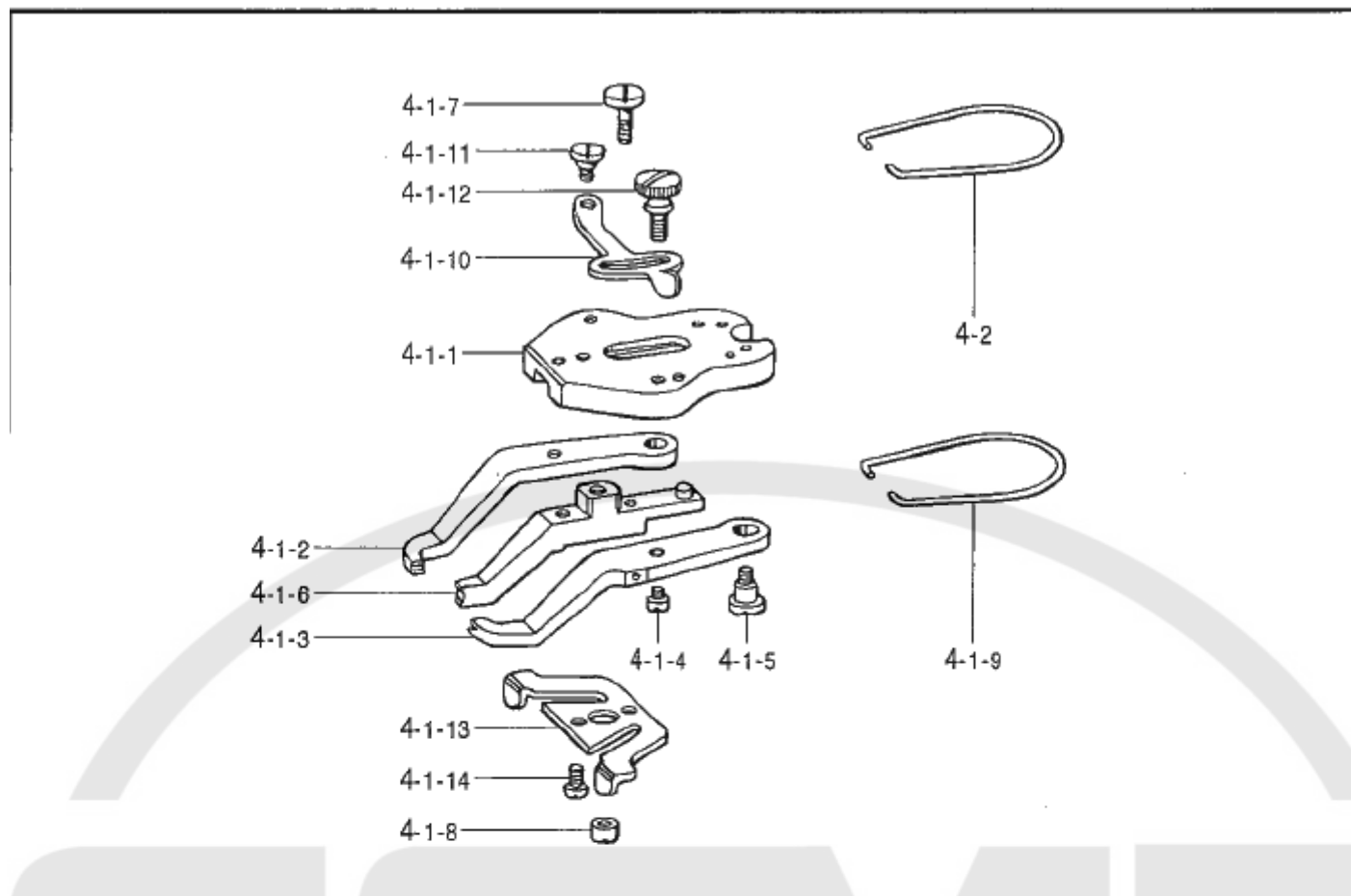

17. オプションパーツ/OPTION PARTS

878-917-940

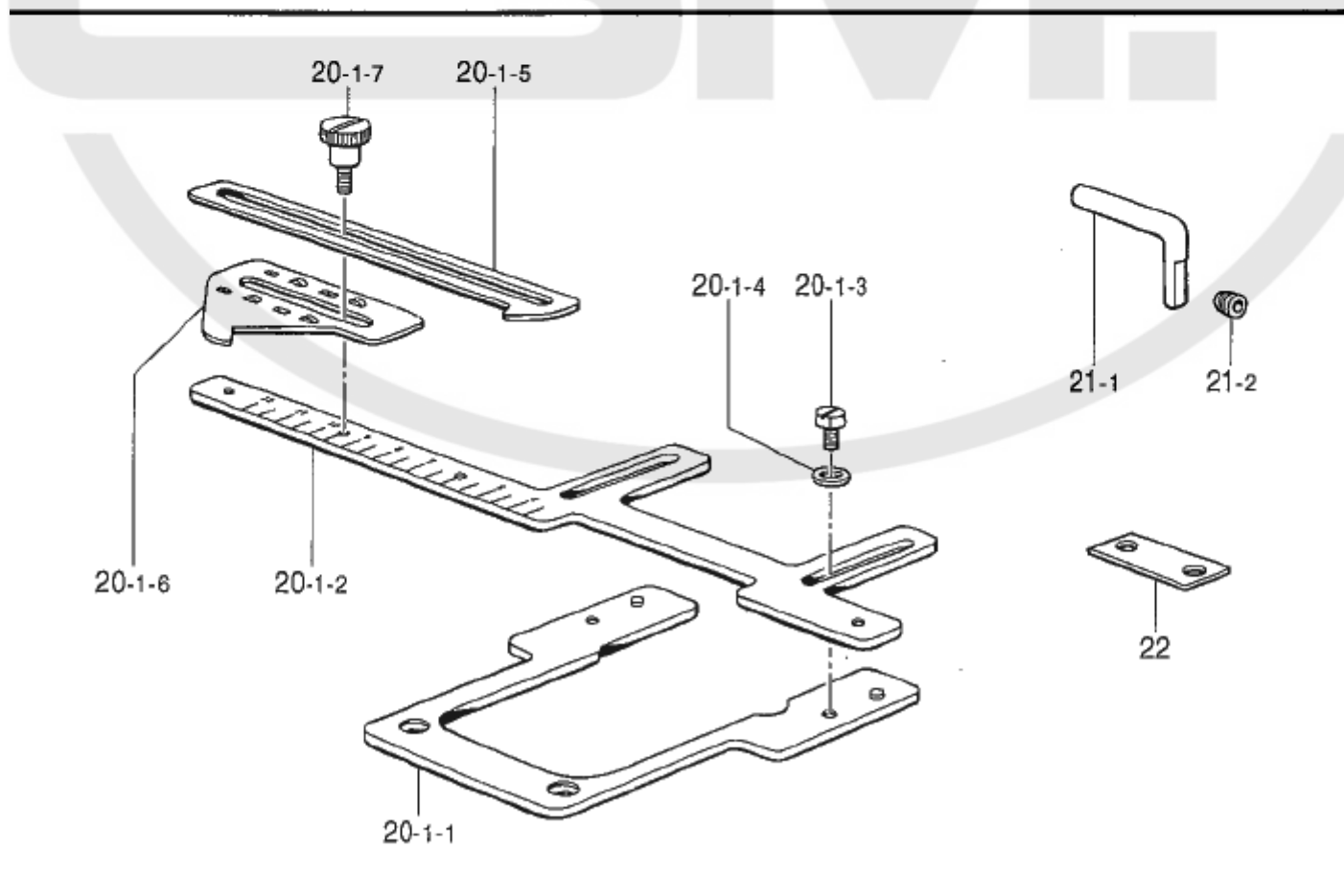

878-917-940

L6. オプションパーツ / Option parts

REF.NO	CODE	QTY	ヒンメイ	NAME OF PARTS	RM
4	S03635101	1	スナップツマミセット	SNAP CLAMP SET	
4-1	S03636101	1	スナップツマミ	SNAP CLAMP ASSY	
4-1-1	S03464101	1	ボタンツカミタイ	BUTTON CLAMP BRACKET	
4-1-2	118541001	1	スナップツマミL	SNAP CLAMP, L	
4-1-3	118539001	1	スナップツマミR	SNAP CLAMP, R	
4-1-4	115156001	2	ボタンツカミアンナヒピン	GUIDE PIN	
4-1-5	115158001	2	タネネジ 4.76	SHOULDER SCREW, SM4.76	
4-1-6	S03712001	1	スナップツマミM	SNAP CLAMP ASSY, M	
4-1-7	S03468101	1	シメネジ 4.37	SCREW, SM4.37	
4-1-8	S03657001	1	マルナツト4.37	NUT, ROUND SM4.37	
4-1-9	115163001	1	ボタンツカミイタハネ	SPRING, PLATE	
4-1-10	115164101	1	ボタンツカミチヨウセツイタ	ADJUSTING PLATE, ;B-CLAMP	
4-1-11	115165001	1	タネネジ 4.37	SHOULDER SCREW, SM4.37	
4-1-12	115166001	1	タネネジ 4.37	SHOULDER SCREW, SM4.37	
4-1-13	S03659001	1	ボタンツカミイタカム	PLATE CAM, ;B-CLAMP	
4-1-14	062680812	2	ナハコ437-40X8	SCREW, PAN SM4.37-40X8	
4-2	S03610001	1	ボタンツカミトシハネ	SPRING, COMPRESSION	

878-917-940

L7. オプションパーツ / Option parts

REF.NO	CODE	QTY	ヒンメイ	NAME OF PARTS	RM
20	S09655001	1	ボタンスペースセット	BUTTON SPACER SET	
20-1	S09656001	1	ボタンスペースクミ	BUTTON SPACER ASSY	
20-1-1	S09657001	1	トタイ	BASE	
20-1-2	S09658001	1	スケール	SCALE	
20-1-3	S09686001	2	ボルト4.37-40X7	BOLT, SM4.37-40X7	
20-1-4	S02745001	2	ワッシャー	WASHER	
20-1-5	S09659001	1	イキメイタA	POSITIONING PLATE, A	
20-1-6	S09660001	1	イキメイタB	POSITIONING PLATE, B	
20-1-7	115166001	1	タネネジ 4.37	SHOULDER SCREW, SM4.37	
21	S38181001	1	ボタンホルダーフッククミ	BUTTON HOLDER HOOK ASSY	
21-1	S36813001	1	ボタンホルダーフック	BUTTON HOLDER HOOK	
21-2	014760622	1	アトメネジ 5.95	SET SCREW, SOCKET SM5.95	
22	S37370001	1	フィードスペース	FEED SPACER	

878-917-940

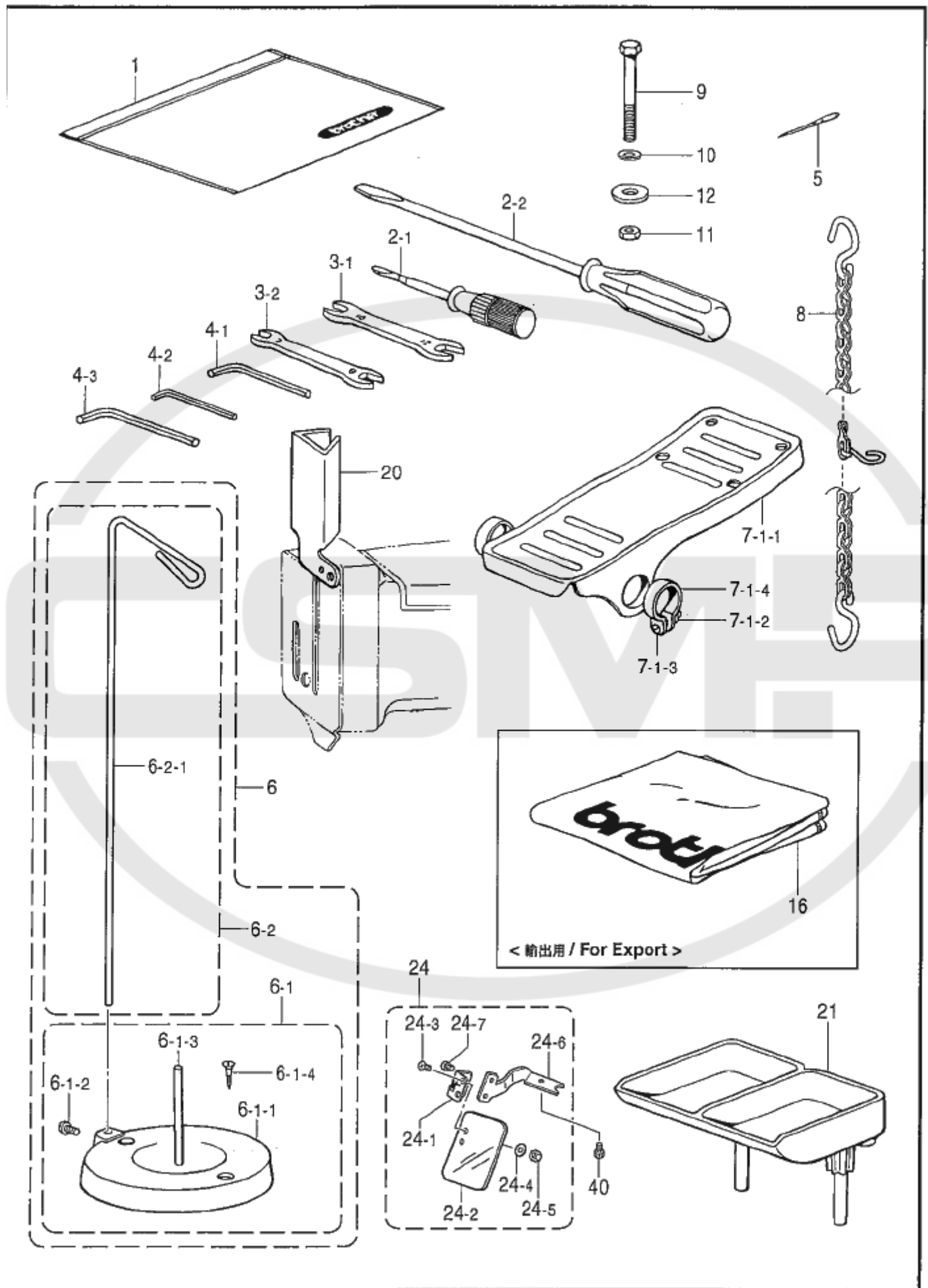

Z1. 付属品関係 / Accessories

REF.NO	CODE	Q'TY	ヒンメイ	NAME OF PARTS	RM
1	122991001	1	フジクシンホリ700	ACCESSORY BAG	
2-1	105344001	1	ネジマワシ2.6X70	SCREW DRIVER, 2.6X70	
2-2	118837001	1	ネジマワシ3.4X70	SCREW DRIVER, 3.4X70	
3-1	107780001	1	スパナ10X12	WRENCH, 10X12	
3-2	142205001	1	スパナ7X8	WRENCH, 7X8	
4-1	142721001	1	6カホウスハナ3	HEXAGONAL WRENCH, 3	
4-2	142002001	1	6カホウスハナ2	HEXAGONAL WRENCH, 2	
4-3	118064001	1	6カホウスハナ4	HEXAGONAL WRENCH, 4	
5	115053014	2	ミシンハリTQX1(#14)	NEEDLE, TQX1 (#14)	
5	115053016	2	ミシンハリTQX1(#16)	NEEDLE, TQX1 (#16)	
5	115053018	2	ミシンハリTQX1(#18)	NEEDLE, TQX1 (#18)	
6	S59553001	1	イトタテイセツ	COTTON STAND SET	
6-1	S59554001	1	イトタテイクミA	COTTON STAND A ASSY	
6-1-1	S59555001	1	イトタテ	DISC	
6-1-2	062501016	1	ナハコ5X10	SCREW, PAN M5X10	
6-1-3	S20135001	1	イトタテウ	SPOOL PIN	
6-1-4	034422006	2	+2サマモク41X20	WOOD SCREW, FLAT 2 M4.1X20	
6-2	S59556001	1	イトタテイクミB	COTTON STAND B ASSY	
6-2-1	S20133001	1	イトタテ	THREAD RETAINER	
7-1	116185209	1	ペダル	PEDAL ASSY	
7-1-1	117437109	1	オキアゲフミタ	FOOT LIFTER PEDAL	
7-1-2	021400106	2	ナット1シユ4	NUT, 1 M4	
7-1-3	062401416	2	ナハコ4X14	SCREW, PAN M4X14	
7-1-4	116016001	2	ペダル止メ	PEDAL STOPPER	
8	142656001	1	クサリ	CHAIN ASSY	
9	144543001	4	ボルト6X63	BOLT, M6X63	
10	025060232	4	ヒサガネ	WASHER, PLAIN M 6	
11	021060102	4	ナット1シユ6	NUT, 1 M6	
12	115947001	4	サカネ	WASHER, PLAIN 6.35	
16	144224001	1		HEAD COVER	
20	S37135001	1	ハリホウカ	NEEDLE BAR COVER	
21	S18642009	1	ボタン	BUTTON TRAY	
24	S44495001	1	アイガード	EYE GUARD ASSY, C	
24-1	S44483001	1	ヒョウハン	HINGE ASSY	
24-2	S44485001	1	アイガード	EYE GUARD	
24-3	061660806	2	サマモク318-40X8	SCREW, FLAT SM3.18-40X8	
24-4	025030232	2	ヒサガネ	WASHER, PLAIN M 3	
24-5	021660102	2	ナット1シユ3.18	NUT, 1 SM3.18	
24-6	S44488001	1	アイガードホルダ	EYE GUARD HOLDER, C	
24-7	062670512	2	ナハコ357-40X5	SCREW, PAN SM3.57-40X5	
40	018400632	1	ソケット	BOLT, SOCKET M4X6	

付属品の明細は変更することがあります。
The details of included accessories are subject to change.

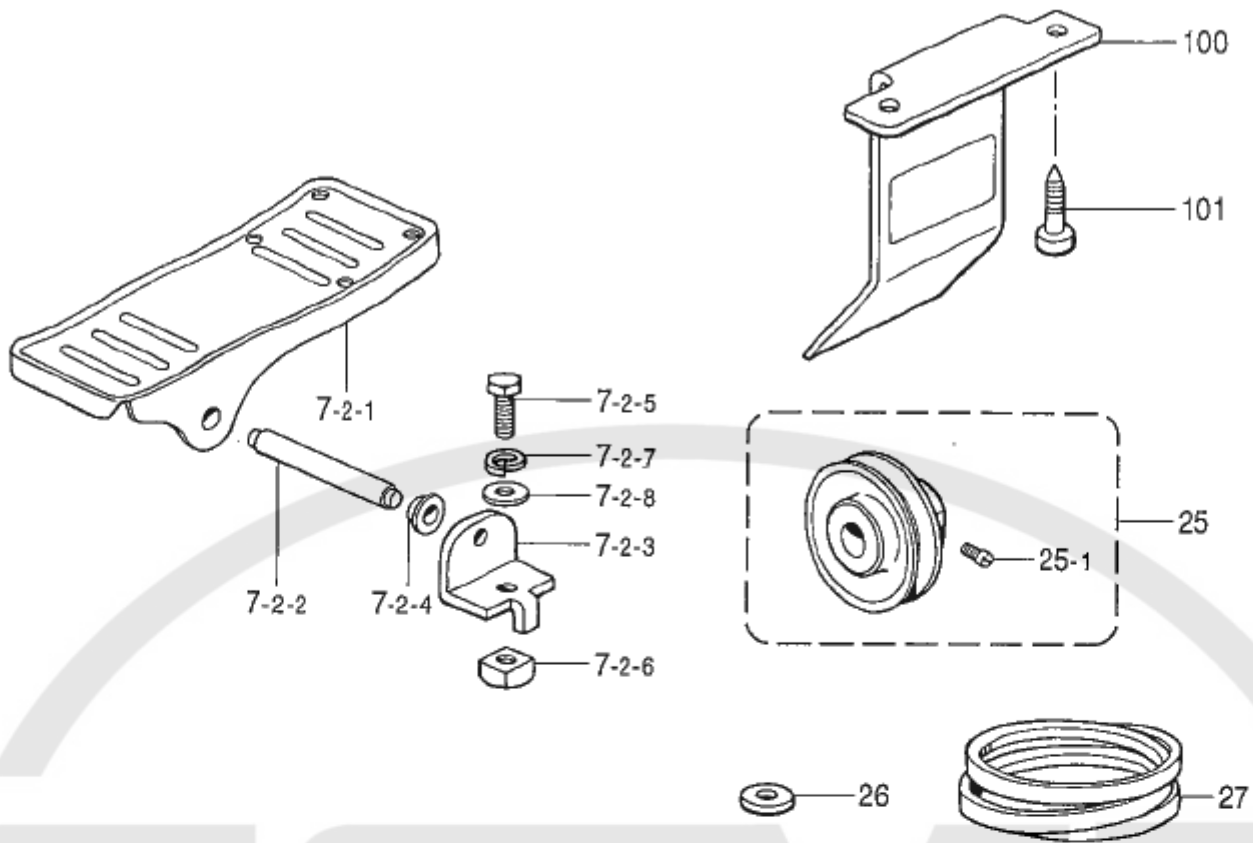

878-917-910



Z2. 付属品関係(オプション部品) / Accessories (Option parts)

REF.NO	CODE	Q'TY	ヒンメイ	NAME OF PARTS	RM
7-2	S01603009	1	オエアケ ^レ フミイタ ^ク ミ (Z脚用)	TREADLE ASSY (For Z-type stand)	
7-2-1	S01199003	1	オエアケ ^レ フミイタ	TREADLE PEDAL	
7-2-2	133188001	1	オエアケ ^レ フミイタ ^ク シ ^ク	TREADLE SHAFT	
7-2-3	119707003	2	フミイタ ^ク ク ^ク カ	BRACKET	
7-2-4	119708001	2	フミイタ ^ク ク ^ク カ ^テ	COLLAR	
7-2-5	017082206	2	ホ ^ル ト8X22	BOLT, M8X22	
7-2-6	116694001	2	4カ ^ク ナ ^ツ ト8	NUT, M8	
7-2-7	028080240	2	ハ ^ネ サ ^カ ネ ² -8	WASHER, SPRING 2-8	
7-2-8	025080236	2	ヒ ^ラ サ ^カ ネ ² ウ ⁸	WASHER, PLAIN M 8	
25	119270001	1	N65 ^フ ー ^リ ー ^ク ミ (60HZ用)	N65 PULLEY ASSY (For 60HZ)	
25	119271001	1	N75 ^フ ー ^リ ー ^ク ミ (50HZ用)	N75 PULLEY ASSY (For 50HZ)	
25-1	105073001	2	ア ^タ マ ^ツ キ ^ト メ ^ネ シ ^{5.95}	SET SCREW, SM5.95	
26	133824001	8	モ ^ー タ ^ー ク ^ク シ ^ヨ ン	CUSHION RUBBER	
27	S18707124	1	V ^ハ ^ル ト ^シ ロ (50HZ用)	BELT, VM WHITE (For 50HZ)	
27	S18707123	1	V ^ハ ^ル ト ^シ ロ (60HZ用)	BELT, VM WHITE (For 60HZ)	
100	S38636101	2	フ ^ー リ ^カ ハ ^ー ク ^ミ	PULLEY COVER ASSY	
101	032422003	4	キ ^ラ ム ^モ ク ^ネ シ ^{4.1X20}	WOOD SCREW, ROUND M4.1X20	

878-917-910

Sp. 仕様別部品一覧表 / Different parts list

仕様 SUB CLASS	縫い目形状 STITCH FORM	針数 NO.OF STITCH	参照番号 REF.NO.	B-1	E1-5	E1-6	E1-7	G-9
			品名 PARTS	ハリカズヘン カンカムクミ Stitch control cam assy	ウォームギヤ クミ Worm gear assy	ヨコオクリ カムクミ Transverse feed cam assy	タテオクリ カムクミ Vertical feed cam assy	ウォームクミ Worm assy
BM-917B -1		8 ・ 16 ・ 32		S36696-001	S03445-001	S03446-001	S03451-001	S03528-001
BM-917B -3			↑	↑	S03447-001	↑	↑	
BM-917B -5			↑	↑	S03446-001	S03452-001	↑	
BM-917B -7	 (仮ラベル付) (Attach label)		↑	↑	↑	S03596-001	↑	
BM-917B -2		6 ・ 12 ・ 24		S36697-001	S03651-001	S03448-001	S03451-001	S03653-001
BM-917B -4			↑	↑	S03449-001	↑	↑	
BM-917B -6			↑	↑	S03448-001	S03454-001	↑	
3M-917B -8	 (仮ラベル付) (Attach label)		↑	↑	↑	S03597-001	↑	

警告ラベル / Warning labels	品名 / Name of parts	Size(mm)	Code
 <p>△ 注意 回転部分が危す。安全器具装着 して、運転をすすめること。 電線が切れてから、入直し、押しこ みの交換、掃除や調整をすること。 △ CAUTION Moving parts may cause injury. Operate with safe- ty devices. Turn off main switch before handling, changing belts and manufacturing etc.</p>	<p>操作注意ラベル・和・英 Label, operation Jpn / Eng.</p>	<p>52 X 84</p>	<p>SA0792-001</p>
 <p>△ 注意 △ 注意 高温部 手触ると 燙傷の原因とな ります。運転中 手触らないこと。 △ CAUTION △ ACHTUNG Heated cover may burn hands. Do not touch when operating. △ ATTENTION △ ATTENCION La zona caliente puede quemar las manos. No tocar durante el funcionamiento.</p>	<p>高温ラベル・6ヶ国語 Label, high temp. 6 lang</p>	<p>87 X 59</p>	<p>SA0795-001</p>
 <p>△ 注意 ベルトに巻き込まれる、危険です。 開口部に手を入れないこと。 △ 注意 定常運転中に入、刃が危険な。 禁止帯子入れ、成閉の開口部。 △ WARNING Rotating belt can cause injury. Do not put hands in opening.</p>	<p>巻き込み注意ラベル 和・中・英 Label, entanglement Jpn / Chn / Eng</p>	<p>52 X 84</p>	<p>SA0794-001</p>
	<p>矢印マーク Label, arrow</p>	<p>10 X 30</p>	<p>S37058-001</p>
	<p>アースマーク Label, grounding</p>	<p>φ 12</p>	<p>S37060-001</p>

878-917B-Wa

CODE	REF.NO	Page	CODE	REF.NO	Page	CODE	REF.NO	Page	CODE	REF.NO	Page
013710512	5-1	12	025030232	24-4	30	102707003	5-1-5	22	115098001	31	8
013710712	19	12	025060232	20-5	12		6-1-1-5	24	115099001	32	8
	11	16		1-4	18	105073001	25-1	32	115101001	17	8
	1-11	16		10	30	105161003	12-3	22	115105001	15	8
	1-9	16	025080236	7-2-8	32	105329001	19	2	115108301	39	8
013719412	5-1-11	22	025680232	44-17	10	105344001	2-1	30	115113001	1-3	2
	6-1-1-11	24	025710232	10-7	2	105812003	1-5	6	115114001	1-4	2
013750512	16-2	14	025800332	11-13	4	106436001	27	2	115115001	1-5	2
013760712	3	4		11-8	4	106629002	10	18	115116001	1-6	2
	4	8	028080240	7-2-7	32	107153001	12	14	115118001	3	2
014680422	16-4	14	032422003	101	32	107231002	3	18	115126001	3	12
014680622	44-8	10	034422006	6-1-4	30	107780001	3-1	30	115156001	44-5-6	10
	8-4	12	047250642	44-5-8	10	108520001	21	2		2-1-6	20
	8-8	12		2-1-8	20	110104000	24	2		2-1-6	20
	1-22	16		2-1-8	20	110124001	13-1	14		4-1-4	28
	6-1-8	24	048040342	1-1-11	18	110161004	16-5	4	115158001	44-5-9	10
014710522	22	4	048050342	8-7	12		73	12		2-1-9	20
014760622	24	4		1-1-10	18		1-1-5	18		2-1-9	20
	4	6	048080142	26	4		7-1-6	24		4-1-5	28
	33	8	060670512	5-7	22	110744002	23-2	12	115163001	2-1-13	20
	35	8		6-7	24	112751003	4-4	4		2-1-13	20
	38	8	061660806	24-3	30	112758001	17	16		4-1-9	28
	10	12	062401416	7-3-3	24	114980001	41	8	115164101	2-1-14	20
	20-10	12		7-1-3	30	114982000	11	2		2-1-14	20
	4	12	062501016	6-1-2	30	114984000	10-3	2		4-1-10	28
	1-1-7	18	062670512	24-7	30		13	2	115165001	2-1-15	20
	21-2	28	062670712	5-1-9	22	114985001	14	2		2-1-15	20
014761030	10-4	2		6-1-1-9	24	114986101	16	2		4-1-11	28
014770622	9-1	2	062670812	5-1-4	22	114988001	20	2	115166001	44-13	10
	1-1-1-4	6		6-1-1-4	24	114992000	4-2	4		2-1-16	20
	5-1	8	062671212	11-3	6	114997001	6	4		2-1-16	20
	6-1	8	062680512	15	2	115000000	8-9	4		20-1-7	28
	7-1	8		16	8	115004001	8-6	4		4-1-12	28
	1-1	12		44-5-7	10	115008000	10	4	115183101	1-13	16
	1-1	14		2-1-7	20		8	14	115186001	1-12-1	16
	5-1	14		2-1-7	20	115011201	11-3	4	115187101	1-10-3	16
	9-1	14	062680812	44-5-15	10	115012002	11-4	4		1-12-2	16
014770632	5-1	6		2-1-18	20	115018001	11-12	4		1-15-2	16
	11-1	12		2-1-18	20	115022001	13	4	115188002	1-12-3	16
014821022	1-1	2		4-1-14	28	115025001	10-5-2	2	115215100	1	4
	8-13	4	062710612	13	6	115042001	1-1-5	6	115268002	10-5-3	2
015770812	1-1-1-3	6		1-14	16	115048101	1-2-1	6	115275001	17	2
017082206	7-2-5	32		1-6	16	115053014	5	30	115947001	12	30
017711412	44-6	10		7-1-4	24	115053016	9	6	116016001	7-3-4	24
	6-1-6	24	062711012	40	8		5	30		7-1-4	30
018061022	44-4	10		16	16	115053018	5	30	116185209	7-3	24
	6-1-4	24		2	16	115066000	16-1	14		7-1	30
018061422	7-2-1	24		4	16	115067001	16-3	14	116694001	7-2-6	32
018062022	16-6	4		5-5	22	115068101	16-5	14	117437109	7-3-1	24
	21	12		6-5	24	115073001	5	14		7-1-1	30
018400632	40	30	062711212	10-6	2	115076001	6	14	117934001	22	2
018680822	6-3	12	062761612	71	12	115077001	7	14	117936001	23	2
021060102	11	30	062780812	20-4	12	115078101	1	8	118064001	4-3	30
021400106	7-3-2	24	071055650	7	4	115080000	3	8	118539001	4-1-3	28
	7-1-2	30	071079450	5	4	115085001	1	18	118541001	4-1-2	28
021660102	24-5	30	100136001	1-10-6	16	115094001	18	8	118837001	2-2	30
021710102	14	8		1-12-4	16	115095001	21	8	119270001	25	32
021750112	10-5-4	2		1-15-5	16		22	8	119271001	25	32
	8-10	4	100251001	10-9	2	115096000	19	8	119707003	7-2-3	32
021800102	11-14	4	100507000	18	12	115097001	20	8	119708001	7-2-4	32
	1-1-4	6	102571003	14	4		30-2	8	120990001	5-1-13	22

CODE	REF.NO	Page	CODE	REF.NO	Page	CODE	REF.NO	Page	CODE	REF.NO	Page
120990001	5-4	22	150556001	66	8	S03419001	2-1	6	S03508001	8-6	12
	6-1-1-13	24		44-12	10	S03420001	3	6	S03509001	9	12
	6-4	24		1-16	16	S03421001	5	6	S03512001	17	12
122991001	1	30	151051201	42	8	S03423001	6	6	S03516001	20-1	12
133188001	7-2-2	32	151602001	16-6	14	S03424000	7	6	S03517101	20-2	12
133824001	26	32	151932001	2	18	S03425000	8	6	S03518001	20-9	12
140553102	10	6	153596001	27	4	S03426101	11	6	S03521001	24	12
141674002	2-2	6	154684009	5-1-1	22	S03427101	11-1	6	S03522001	1	14
142002001	4-2	30		6-1-1-1	24	S03428001	11-2	6	S03523101	2	14
142205001	3-2	30	154685001	5-1-7	22	S03429101	12	6	S03524000	3	14
142307101	10-5-1	2		6-1-1-7	24	S03433001	1-2	2	S03525000	4	14
142570109	5	22	154686001	5-1-10	22	S03436001	2	2	S03526001	5	14
142656001	7-4	24		6-1-1-10	24	S03437001	4	2	S03528001	9	14
	8	30	155510001	12-4	16	S03438001	5	2	S03533001	13	14
142658001	1-1-1-1	6	155559001	1-1-12	18	S03439001	6	2	S03536001	15	14
142677101	5-1-2	22	156336101	5-6	22	S03440001	7	2	S03538109	1-1	16
	6-1-1-2	24		6-6	24	S03441001	8	2	S03540001	1-3	16
142678101	5-1-3	22	156874001	72	12	S03442001	9	2	S03541001	1-4	16
	6-1-1-3	24	159805001	1-10-4	16	S03444000	2	8	S03542001	1-5	16
142680001	5-1-12	22		1-15-3	16	S03445001	5	8	S03543101	1-8	16
	6-1-1-12	24	183943001	11	14	S03446001	6	8	S03544101	1-10	16
142681001	5-1-6	22	S01199003	7-2-1	32	S03447001	6	8	S03545001	1-10-1	16
	6-1-1-6	24	S01295001	8-4	26	S03448001	6	8	S03546001	1-10-2	16
142683101	5-2	22	S01603009	7-2	32	S03449001	6	8	S03549001	1-15	16
	6-2	24	S01696001	2	14	S03451001	7	8	S03550001	1-15-1	16
142684001	5-3	22	S01702001	15	6	S03452001	7	8	S03551001	1-17	16
	6-3	24	S02745001	20-1-4	28	S03454001	7	8	S03556001	1-18	16
142686101	5-8	22	S03372109	10-2	2	S03459051	44-2	10	S03557001	1-19	16
	6-8	24	S03374109	12	2		6-1-3	24	S03558001	1-20	16
142687101	5-10	22	S03376001	18	2	S03464101	44-5-1	10	S03560001	10	16
	6-10	24	S03377101	12-1	16		2-1-1	20	S03561201	12	16
142688001	5-11	22	S03378000	2	4		2-1-1	20	S03564001	13	16
	6-11	24	S03379101	4	4		4-1-1	28	S03565001	14	16
142689309	5-1	22	S03381101	8	4	S03467001	44-5-10	10	S03566001	15	16
	6-1-1	24	S03382101	8-1	4		2-1-10	20	S03567001	1	14
142706001	5-1-8	22	S03383001	8-2	4	S03468101	44-5-11	10	S03596001	7	8
	6-1-1-8	24	S03384001	8-3	4		2-1-11	20	S03597001	7	8
142721001	4-1	30	S03385000	8-4	4		2-1-11	20	S03600001	44-9	10
144224001	16	30	S03386001	8-5	4		4-1-7	28	S03604001	44-10	10
144504001	12-2	16	S03387001	8-7	4	S03471001	10	8	S03605001	44-11	10
144505000	12-3	16	S03388001	8-11	4	S03472001	11	8	S03606001	44-14	10
144543001	9	30	S03392001	11-2	4	S03473001	12	8	S03607001	44-15	10
145480101	22	12	S03393001	11-6	4	S03474001	13	8	S03608001	44-16	10
146354001	44-7	10	S03394001	11-7	4	S03476101	23	8	S03610001	44-5-13	10
	20-8	12	S03395000	11-9	4		1	18		2-2	20
	1-7	16	S03401001	11-16	4	S03478101	26	8		2-2	20
	5	16	S03402001	12	4	S03480001	28	8		4-2	28
	6-1-7	24	S03403001	15	4	S03482101	30	8	S03611001	37	8
146360002	24	8	S03405101	16-1	4	S03484101	30-1	8	S03612101	20	12
	43	8	S03406101	1-1-2	18	S03485001	34	8	S03613001	20-3	12
	20-7	12	S03407001	16-3	4	S03486001	36	8	S03614001	20-6	12
147151000	10	14		1-1-3	18	S03488001	1	12	S03615109	1	16
	6	14	S03408001	16-4	4	S03489101	2	12	S03616101	1-2	16
147691000	28	2		1-1-4	18	S03490001	5	12	S03617001	3	16
148425002	1-1-2-1	6	S03409001	1	6	S03496101	6-2	12	S03621001	1-1-8	18
148924101	1-10-5	16	S03410001	1-1	6	S03500001	8	12	S03622101	1-2	18
149996001	11-15	4	S03412000	1-1-1-2	6	S03501000	8-1	12	S03623001	1-1-9	18
	8-12	4	S03414001	1-1-3	6	S03502001	8-2	12	S03624001	4	18
150416001	11	26	S03415001	1-2	6	S03503001	13	12		7-2-3	24
150553001	1-3	18	S03417000	1-3	6		8-3	12	S03625001	7-1-5	24
150554002	11-5	4	S03418000	1-4	6	S03504001	8-5	12		7-2-2	24

CODE	REF.NO	Page	CODE	REF.NO	Page	CODE	REF.NO	Page	CODE	REF.NO	Page
S03626001	6	18	S09490001	11-2-2	26	S36616001	11-1	4			
S03627001	7	18	S09491001	11-2-3	26	S36617001	1-1-1	18			
S03628001	8	18	S09492001	11-2-4	26	S36622001	14	6			
S03629001	9	18	S09493001	9-7	26	S36624001	3	14			
S03630101	1	18	S09494001	9-4	26	S36625001	4	14			
S03632101	1	18	S09495001	11-2-6	26	S36626001	8	8			
S03633001	2	20	S09496001	11-2-5	26	S36629001	6	12			
S03634101	2-1	20	S09564001	11-2	26	S36630001	6-1	12			
S03635101	4	28	S09655001	20	28	S36633001	15	12			
S03636101	4-1	28	S09656001	20-1	28	S36642001	21	4			
S03641101	5-9	22	S09657001	20-1-1	28	S36693001	11-11	4			
	6-9	24	S09658001	20-1-2	28	S36694001	16	4			
S03649001	44-5-4	10	S09659001	20-1-5	28	S36695001	16-2	4			
	2-1-4	20	S09660001	20-1-6	28	S36696001	1	2			
S03650001	44-5-2	10	S09686001	20-1-3	28	S36697001	1	2			
	2-1-2	20	S10560001	12-1	22	S36699001	16	14			
S03651001	5	8	S10651001	12-2	22	S36700001	28	4			
S03653001	9	14	S10652000	12-5	22	S36813001	21-1	28			
S03655002	7	24		13-1	22	S36816001	10-8	2			
S03657001	44-5-12	10	S10653000	12-6	22	S37058001		34			
	2-1-12	20		13-2	22	S37060001		34			
	2-1-12	20	S10654001	12	22	S37133001	23	4			
	4-1-8	28	S10655001	13	22	S37135001	20	30			
S03659001	44-5-14	10	S10667001	25	8	S37352009	44-1	10			
	2-1-17	20	S10668001	9	4		6-1-2	24			
	2-1-17	20		7	14	S37362001	18	4			
	4-1-13	28	S11079001	44-5-3	10	S37369001	1	18			
S03692001	8	26		2-1-3	20	S37370001	22	28			
S03693001	9	26	S11080001	44-5-5	10	S37436109	44	10			
S03695001	44-3	10		2-1-5	20	S37438109	44	10			
	6-1-5	24	S16121101	1	18	S37439000	70	12			
S03701001	2	20	S16253001	1-23	16	S37444001	9	8			
S03704002	11	12	S18642009	21	30	S37805001	7-2	24			
S03705001	7-1-1	24	S18707123	27	32	S38181001	21	28			
S03706001	7-1-2	24	S18707124	27	32	S38636101	100	32			
S03707001	7-1-3	24	S20133001	6-2-1	30	S39086001	12-4	22			
S03712001	4-1-6	28	S20135001	6-1-3	30	S39092000	69	8			
S03714001	7-1	24	S20740101	25	4	S39822109	6	24			
S03719001	1-1-1	6	S29954001	44-5-10	10	S39823109	6-1	24			
S03720001	1-1-2	6		2-1-10	20	S39973001	11-1	14			
S05724001	10	2	S29998001	44-5-2	10	S44483001	24-1	30			
S05725001	8-8	4		2-1-2	20	S44485001	24-2	30			
S06057001	1-12	16	S29999001	44-5-4	10	S44488001	24-6	30			
S06253201	1-21	16		2-1-4	20	S44495001	24	30			
S06432001	1-15-4	16	S30001001	44-5-3	10	S59553001	6	30			
S06682101	44-5	10		2-1-3	20	S59554001	6-1	30			
S07995001	10-5	2	S30002001	44-5-5	10	S59555001	6-1-1	30			
S09043000	67	8		2-1-5	20	S59556001	6-2	30			
S09143001	8-2	26	S30015101	2-1	20	SA0792001		34			
S09144001	8-1	26	S30016101	44-5	10	SA0794001		34			
S09145001	8-3	26	S31723001	29	8	SA0795001		34			
S09146001	23	12	S31724001	27	8	SA1086001	1-1	18			
S09147001	23-1	12	S34278001	1-1-6	18						
S09482001	9-1	26	S34298001	5	18						
S09483001	9-2	26	S34340001	4-3	4						
S09484001	9-3	26	S34341001	4-1	4						
S09485001	9-5	26	S34806001	11-10	4						
S09486001	9-6	26	S35727001	17	4						
S09487001	9-8	26	S36590009	10	2						
S09488001	11-1	26	S36591000	10-1	2						
S09489001	11-2-1	26	S36615001	11	4						

brother®

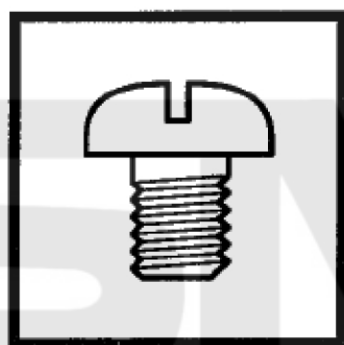

パーツブック
PARTS BOOK

ブラザー工業株式会社

BROTHER INDUSTRIES, LTD

Printed in Japan

878-917
SA0724-001
2002.10. C(1)