

brother

PARTS BOOK

BAS-330



Programmable Electric Lock Stitch Bar
Tacking Machine Profile S

BROTHER INDUSTRIES, LTD.

NAGOYA, JAPAN

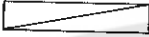

Notes for using this parts book

1. If the symbol  is found in the "Parts No." column or the "Assembly No." column, refer to the different parts list page 23.
2. The symbol  in the "Parts No." column indicates that the parts is not available for supply. If, however, there is a number in the "Assembly No." column, the parts can be ordered as an assembly. Please, therefore, order by using the Assembly No.
3. This book was prepared based on information available in April, 1981.
4. Parts are subject to changes in design without prior notice.

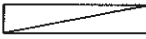

Anmerkungen zum Gebrauch dieses Stücklistebuches

1. Dieses Zeichen  in der Spalte "Parts No. (Teilnummer)" oder "Assembly No. (Gerätesatznummer)" verweist auf die Gesonderte Stückliste auf Seite 23.
2. Dieses Zeichen  in der Spalte "Teilnummer" bedeute, daß dieser Teil nicht lieferbar ist. Wenn Jedoch in der Spalte "Gerätesatznummer" eine Nummer steht, kann dieser Teil als ein Geräteteilsatz bestellt werden. Bestellen Sie daher bitte mit dieser Gerätesatznummer.
3. Dieses Buch basiert auf den Informationen vom April, 1981.
4. Modelländerungen sind vorbehalten.

Notes sur l'utilisation de ce manuel de pièces détachées

1. Si le symbole  se trouve dans la colonne "Parts No. (N° de pièce)" ou dans la colonne "Assembly No. (N° jeu de pces)", veuillez vous référer à la liste de pièces annexe page 23.
2. Le symbole  dans la colonne "N° de pièce" signifie que la pièce ne peut être fournie. Si, dans la colonne "N° jeu de pces", il y a un numéro de nomenclature, la pièce peut être commandée comme faisant partie d'un jeu de pièces. Donc, pour toute commande, veuillez spécifier le N° de jeu de pièces.
3. Ce manuel a été fait d'après les renseignements valables au mois de Avril, 1981.
4. Les pièces peuvent être sujettes à des modifications sans préavis.

Notas para usar este Libro de Piezas

1. De haber un símbolo  junto al "Parts No. (Número de Pieza)" o en la columna del "Assembly No. (Número de Juego)", habrá que mirar la lista de piezas separada de la página 23.
2. El símbolo  , que se encuentra en la columna del "Número de Pieza", quiere decir que no se dispone de dicha pieza sola. Cuando, empero, hay un número en la columna del "Numero de Juego", se podrá ordenar la pieza con todo el juego. Por lo tanto, será mejor hacer el pedido recurriendo al número del juego respectivo.
3. Este libro ha sido compilado basándose en los datos de que se disponía en abril de 1981.
4. Las piezas quedan sujetas a cambios de diseño sin aviso previo.

CONTENTS

A. Machine Body	1
B. Upper Shaft · Lower Shaft and Needle Bar Mechanism	2
C. Pulley and Clutch Mechanism	3
D. Power Lift and Clutch Mechanism	4
E. Presser Arm Mechanism	5
F. Feed Mechanism (1)	6
F. Feed Mechanism (2)	7
G. Vertical Shaft Mechanism	8
H. Work Clamp and Thread Wiper Mechanism	9
J. Thread Trimming and Thread Nipper Mechanism	10
K. Bobbin Winder and Threading Mechanism	11
L. Oil Pan	12
M. Lubrication	13
N. Synchronizer	14
P. Intermittent Presser Foot Mechanism	15
Q. Table Unite	16
R. Power Supply Equipment Mechanism (1)	17
R. Power Supply Equipment Mechanism (2)	18
T. Actuator Mechanism	19
Z. Accessories (1)	20
Z. Accessories (2)	21
a. Programmer Device	21
b. Optional Parts	22
DIFFERENT PARTS LIST	23
INDEX	24

A. Machine Body

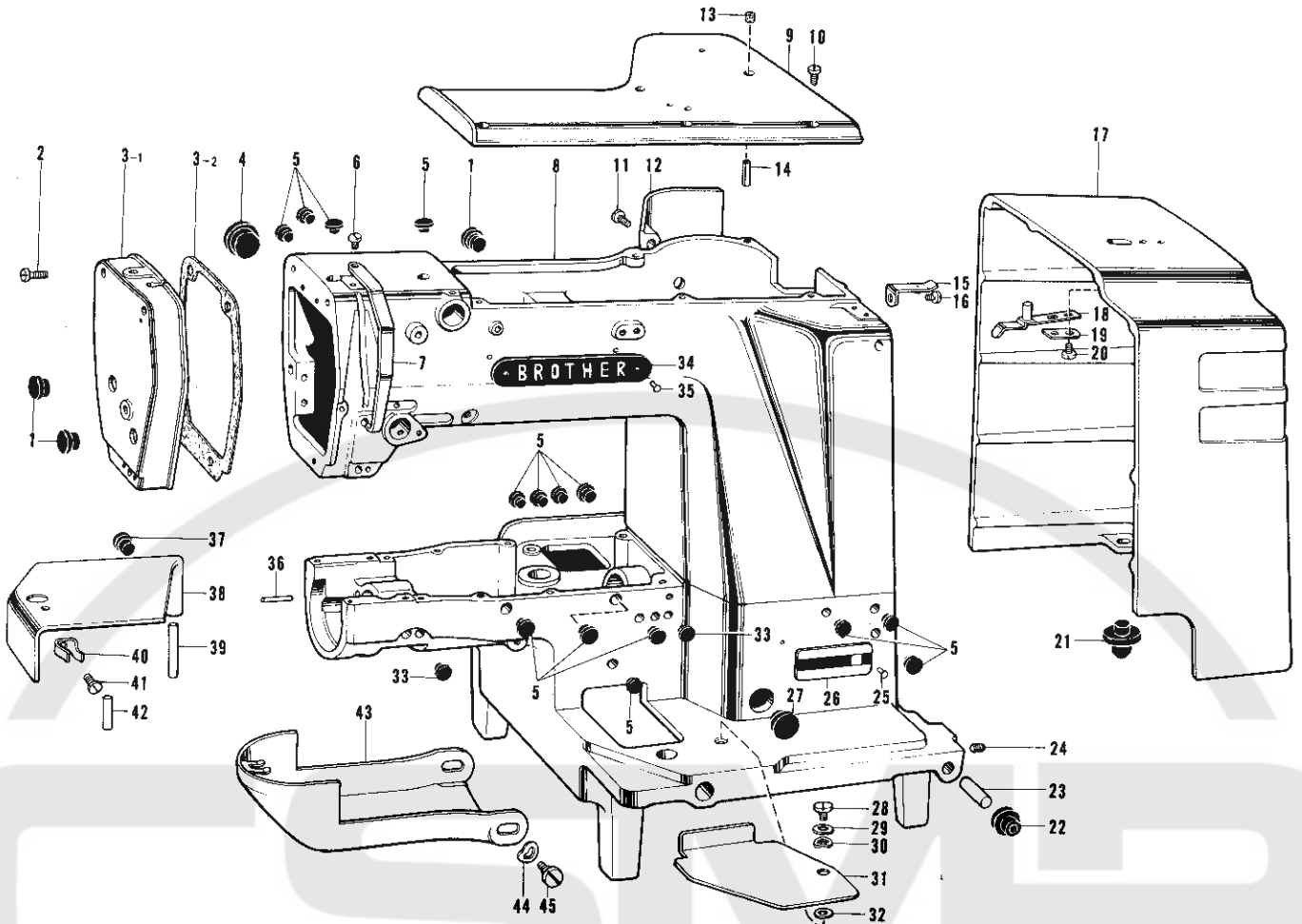

Ref. No.	Name of Parts	Q'ty	Parts No.	Assembly No.	Ref. No.	Name of Parts	Q'ty	Parts No.	Assembly No.
A-1	Oil Cap	3	117934-0-01		A-23	Hinge Shaft	2	152867-0-00	
A-2	Screw 4.76 x 14	3	009711-4-12		A-24	Screw 5.95	2	151604-0-02	
A-3-1	Face Plate	1	155583-0-01	A-3 Face Plate Assembly 155582-0-01	A-25	Pin	2		
A-3-2	Packing	1	152833-0-01		A-26	Model Plate 441	1		
A-4	Oil Cap	1	140392-0-01		A-27	Oil Cap	1	108520-0-01	
A-5	Oil Cap	15	117936-0-01		A-28	Screw 6.35	1	145480-0-01	
A-6	Screw 3.57 x 8	1	009670-8-12		A-29	Washer	1	118719-0-01	
A-7	Thread Take-up Cover	1	152841-0-02		A-30	Washer	1	100315-0-02	
A-8	Arm Bed	1			A-31	Bed Cover (R)	1	152835-0-02	
A-9	Top Cover	1	152830-0-02		A-32	Washer 6.35	1	025770-2-32	
A-10	Screw 5.95 x 14	6	009761-4-12		A-33	Vinyl Cap	2	104450-0-01	
A-11	Screw 4.76 x 14	3	009711-4-12		A-34	Name Plate	2		
A-12	Side Cover	1	152834-0-02		A-35	Pin	4		
A-13	Felt	2	154785-0-00		A-36	Pin	1	141808-0-01	
A-14	Spring Pin AW5	2	047501-2-42		A-37	Vinyl Cap	1	104450-0-01	
A-15	Belt Cover Spring Plate	1	152989-0-01		A-38	Bed Cover (L)	1	152836-0-02	
A-16	Screw 4.37 x 8	1	009680-8-12		A-39	Bed Cover Shaft	1	152839-0-01	
A-17	Belt Cover	1	152846-0-02		A-40	Bed Cover Stop Spring	1	114985-0-01	
A-18	Belt Cover Spring	1	152848-0-01		A-41	Screw 4.37 x 6	1	009680-6-12	
A-19	Belt Cover Stopper	1	152986-0-01		A-42	Grooved Pin	1	152838-0-01	
A-20	Screw 4.37 x 8	2	009680-8-12		A-43	Shuttle Race Cover Assembly	1	152842-0-02	
A-21	Packing	2	152847-0-00		A-44	Washer	2	109239-0-02	
A-22	Head Cushion	2	152868-0-00		A-45	Screw 5.95	2	115493-0-02	

B. Upper Shaft · Lower Shaft and Needle Bar Mechanism

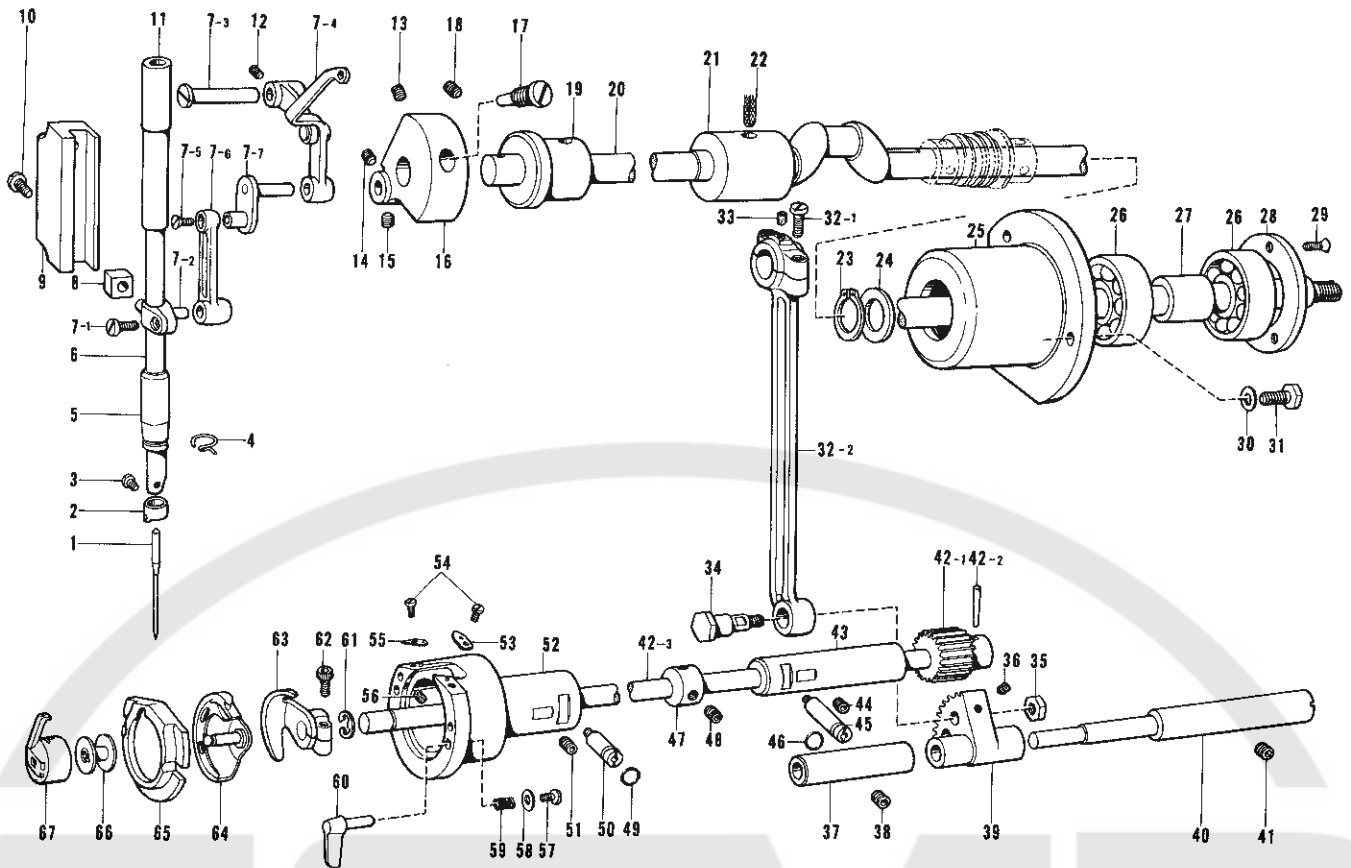

Ref. No.	Name of Parts	Q'ty	Parts No.	Assembly No.	Ref. No.	Name of Parts	Q'ty	Parts No.	Assembly No.
B-1	Needle	1			B-33	Felt	1	107149-0-01	
B-2	Needle Bar Thread Guide	1			B-34	Screw	1	141786-0-01	
B-3	Screw 3.57	1	144458-0-01		B-35	Nut 7.14	1	104689-0-01	
B-4	Thread Guide (D)	1	152891-0-01		B-36	Screw 4.37 x 6	1	014680-6-22	
B-5	Needle Bar Bushing (D)	1	152243-0-01		B-37	Rock Shaft Bushing	1	152247-0-01	
B-6	Needle Bar	1			B-38	Screw 5.95 x 6	1	014760-6-22	
B-7-1	Screw 4.37 x 8	1	009680-8-12		B-39	Rock Gear	1	152245-0-01	
B-7-2	Needle Bar Clamp	1	152239-0-01		B-40	Rock Gear Shaft	1	152246-0-01	
B-7-3	Stud	1	152236-0-01		B-41	Screw 5.95 x 6	1	014760-6-22	
B-7-4	Thread Take-up Assembly	1	153330-0-01	B-7 Thread Take-up Lever Assembly 152232-0-01	B-42-1	Lower Shaft Gear	1		B-42 Lower Shaft Assembly 152191-0-01
B-7-5	Screw 3.57L	1	100253-0-01		B-42-2	Taper Pin 3 x 16	1	046301-6-20	
B-7-6	Needle Bar Connector	1	152238-0-01		B-42-3	Lower Shaft	1		
B-7-7	Needle Bar Crank	1	152237-0-01		B-43	Lower Shaft Bushing	1	152250-0-01	
B-8	Slide Block	1	142211-0-01		B-44	Screw 5.95 x 6	1	014760-6-22	
B-9	Needle Bar Guide	1	152244-0-00		B-45	Driver Adjusting Stud	1	152676-0-01	
B-10	Screw 6.35 x 14	2	009781-4-12		B-46	Packing	1	081003-6-70	
B-11	Needle Bar Bushing (U)	1	152242-0-01		B-47	Collar	1	110495-0-03	
B-12	Screw 5.95	1	013761-4-12		B-48	Screw 6.35 x 6	2	014770-6-22	
B-13	Screw 6.35 x 6	1	014770-6-22		B-49	Packing	1	081003-6-70	
B-14	Screw 6.35 x 6	1	014770-6-22		B-50	Shuttle Hook Adjusting Stud	1	152678-0-01	
B-15	Screw 6.35	1	101706-0-01		B-51	Screw 5.95 x 6	1	014760-6-22	
B-16	Counter Weight	1	152231-0-00		B-52	Shuttle Race Body	1	152677-0-01	
B-17	Screw 7.14	1	100250-0-01		B-53	Shuttle Race Thread Guide (R)	1	152679-0-01	
B-18	Screw 5.95	1	013761-4-12		B-54	Screw 3.18 x 3	2	009660-3-12	
B-19	Upper Shaft Bushing (Front)	1	152000-0-01		B-55	Shuttle Race Thread Guide (L)	1	152680-0-01	
B-20	Upper Shaft	1	151995-0-01		B-56	Felt	2	153050-0-00	
B-21	Upper Shaft Bushing (Intermediate)	1	140726-0-00		B-57	Screw 3.18 x 7	2	009660-7-12	
B-22	Wick 4 x 4	1	153925-0-01		B-58	Washer 3.2	2	402887-0-01	
B-23	Stop Ring C15	1	048150-1-42		B-59	Spring	2	152684-0-01	
B-24	Thrust Ring	1	116920-0-01		B-60	Shuttle Race Ring Set Claw	2	152683-0-01	
B-25	Ball Bearing Case	1	151997-0-00		B-61	Stop Ring E8	1	048080-3-42	
B-26	Ball Bearing	2	072630-2-60		B-62	Bolt 5 x 14	1	018501-4-22	
B-27	Bearing Collar	1	151998-0-00		B-63	Driver	1	152681-1-01	
B-28	Bearing Cap	1	151999-0-01		B-64	Shuttle Hook	1		
B-29	Screw 3.57	3	102843-0-04		B-65	Shuttle Race Ring	1		
B-30	Washer 6	3	025060-2-32		B-66	Bobbin	1		
B-31	Bolt 5.95 x 14	3	017761-4-12		B-67	Bobbin Case Assembly	1		
B-32-1	Screw 4.76	2	144712-0-02	B-32 Crank Rod Assembly 153040-0-01					
B-32-2	Crank Rod	1							

C. Pulley and Clutch Mechanism

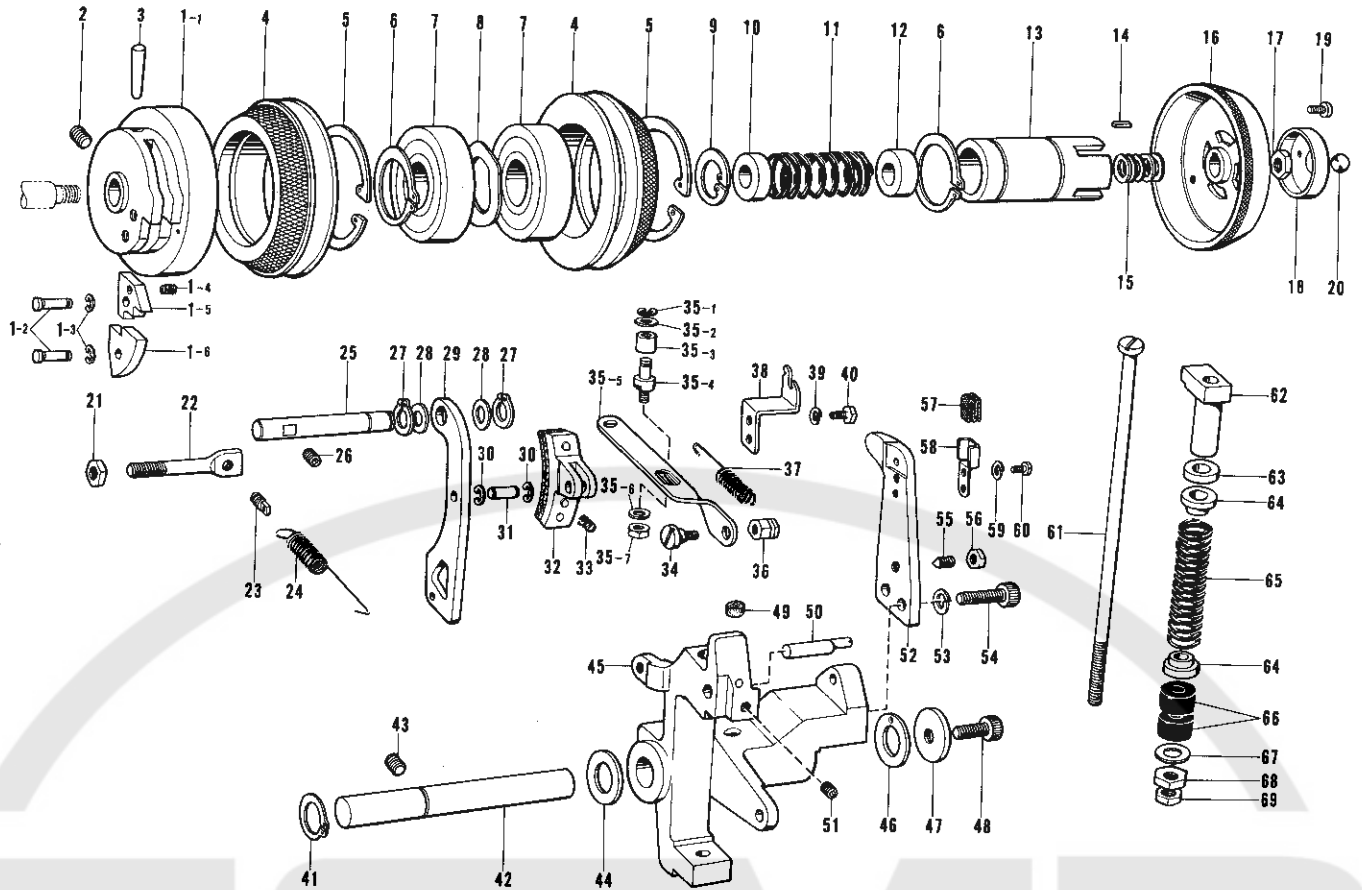

Ref. No.	Name of Parts	Q'ty	Parts No.	Assembly No.	Ref. No.	Name of Parts	Q'ty	Parts No.	Assembly No.
C- 1-1	Stop Cam	1		C-1 Stop Cam Assembly 153044-0-01	C-35-2	Washer	1	113431-0-02	C-35 Clutch Lever Rod Assembly 151904-1-01
C- 1-2	Pin	2	153058-0-01		C-35-3	Roller	1	107744-0-01	
C- 1-3	Stop Ring E4	2	048040-3-42		C-35-4	Roller Stud	1	151906-1-01	
C- 1-4	Brake Cam Segment Spring	1	152694-0-01		C-35-5	Clutch Lever Rod	1	151905-1-01	
C- 1-5	Brake Cam Segment	1	152693-0-01		C-35-6	Washer 4.37	1	025680-1-33	
C- 1-6	Flange Cam Segment	1	115003-0-01		C-35-7	Nut 4.37	1	021680-2-02	
C- 2	Screw 6.35 x 6	1	014770-6-22		C-36	Nut 5.95	1	151908-0-01	
C- 3	Spring Pin 6 x 36	1	147111-0-01		C-37	Spring	1	155501-0-01	
C- 4	Pulley Assembly	2	152695-0-01		C-38	Spring Hook	1	151910-0-01	
C- 5	Stop Ring C62	2	048620-2-42		C-39	Washer 2-5	2	028050-2-42	
C- 6	Stop Ring C35	2	048350-1-42		C-40	Bolt 4.76	2	117363-0-01	
C- 7	Bearing 6007VV	2	072600-7-60		C-41	Stop Ring C18	1	048180-1-42	
C- 8	Washer	1	152699-0-01		C-42	Clutch Lever Shaft	1	151887-0-01	
C- 9	Stop Ring C24	1	048240-2-42		C-43	Screw 7.94 x 10	1	014821-0-22	
C-10	Slide Bush (B)	1	151946-0-00		C-44	Washer 18	1	152756-0-01	
C-11	Clutch Spring	1	152701-0-01		C-45	Clutch Lever	1	151886-0-01	
C-12	Slide Bush (A)	1	152700-0-00	C-46	Washer 18	1	151929-0-00		
C-13	Slide Metal	1	152698-0-01	C-47	Washer 8	1	152728-0-01		
C-14	Key 3 x 3 x 6	1	152704-0-00	C-48	Bolt 8 x 15	1	151163-0-01		
C-15	Spacer	5	152703-0-00	C-49	Felt	1	151927-0-01		
C-16	Clutch (S)	1	155589-0-01	C-50	Brake Side Pin	1	151901-0-01		
C-17	Nut 10L	1	152705-0-01	C-51	Screw 5.95 x 6	1	014760-6-22		
C-18	Ball Holder	1	152706-0-01	C-52	Ball Presser Plate	1	151888-1-01		
C-19	Screw 3.18 x 7	4	009660-7-12	C-53	Washer 2-8	2	028080-2-42		
C-20	Steel Ball 3/8	1	071095-2-50	C-54	Bolt 8 x 25	2	018082-5-22		
C-21	Nut 7.94	1	106147-0-01	C-55	Screw 6.35	1	115012-0-02		
C-22	Spring Hook	1	151903-0-01	C-56	Nut 6.35	1	150554-0-02		
C-23	Spring Hook	1	110251-0-01	C-57	Wick	1	152977-0-01		
C-24	Brake Spring	1	151902-0-01	C-58	Wick Holder	1	152976-0-01		
C-25	Brake Lever Shaft	1	151900-0-01	C-59	Washer 2-4	2	028040-2-42		
C-26	Screw 5.95	1	013761-4-10	C-60	Screw 3.57	2	009670-5-12		
C-27	Stop Ring C11	2	048110-1-42	C-61	Stopper Bar	1	151893-0-01		
C-28	Horizontal Feed Crank Ring	2	142628-0-01	C-62	Clutch Stopper	1	151889-0-01		
C-29	Brake Lever	1	151894-0-01	C-63	Cushion Rubber	1	151890-0-00		
C-30	Stop Ring E4	2	048040-3-42	C-64	Spring Holder	2	151892-0-01		
C-31	Brake Shaft	1	151898-0-01	C-65	Clutch Spring	1	151891-0-01		
C-32	Brake Assembly	1	151895-0-00	C-66	Cushion Rubber	2	115018-0-01		
C-33	Spring	1	151899-0-01	C-67	Washer 7.14	1	025800-3-33		
C-34	Screw 5.95	1	151907-0-01	C-68	Nut 7.14	1	021800-1-03		
C-35-1	Stop Ring E3	1	048030-3-42	C-69	Nut 7.14	1	104689-0-01		

D. Power Lift and Clutch Mechanism

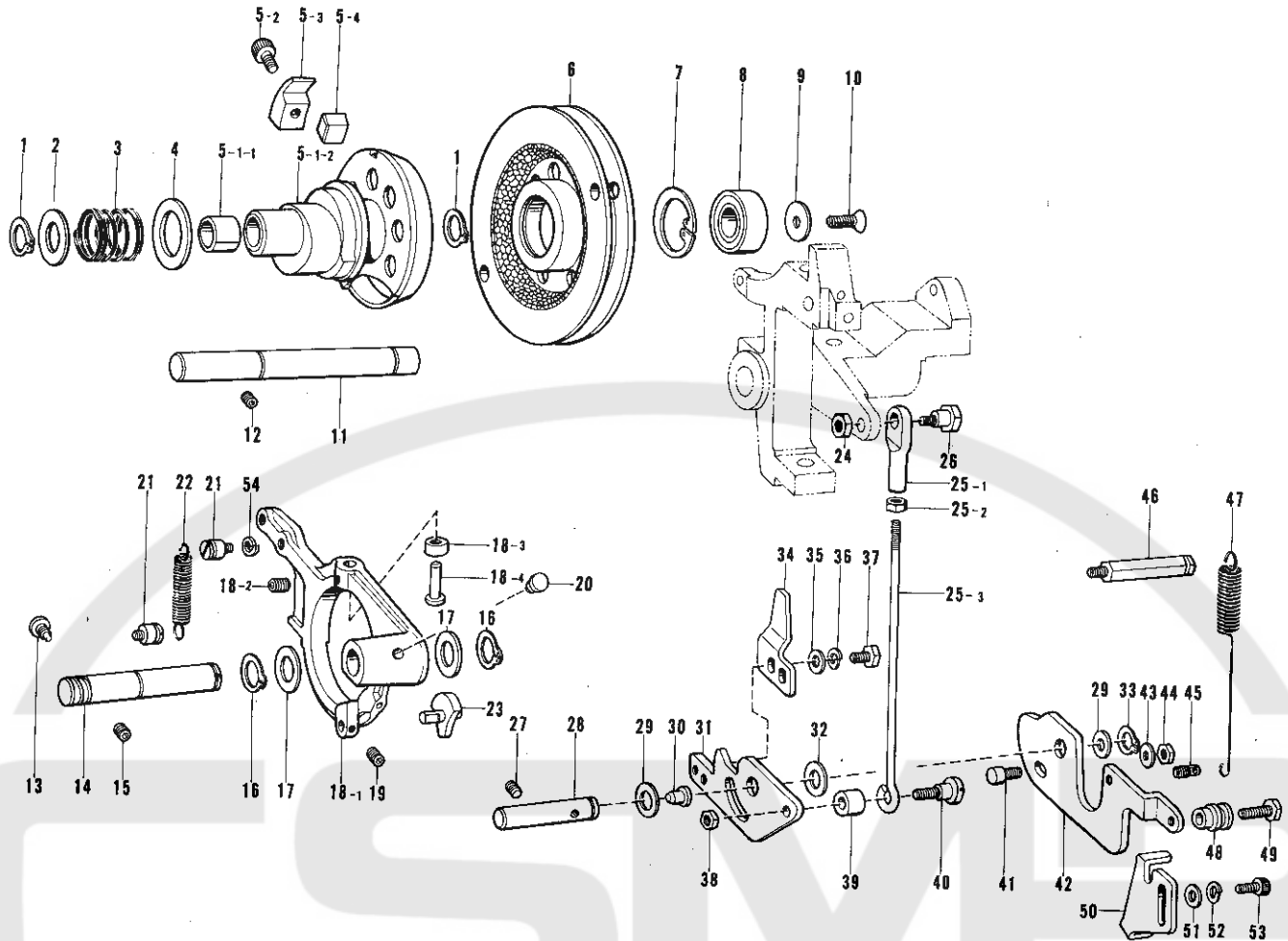

Ref. No.	Name of Parts	Q'ty	Parts No.	Assembly No.	Ref. No.	Name of Parts	Q'ty	Parts No.	Assembly No.
D- 1	Stop Ring C17	2	048170-1-42		D-25-1	Joint	1	154333-0-01	D-25
D- 2	Washer 17	1	151937-0-01		D-25-2	Nut 6.35	1	150555-0-01	Connecting Rod
D- 3	Clutch Spring P	1	151936-0-01		D-25-3	Connecting Rod	1	154332-0-01	Assembly
D- 4	Washer	1	151938-0-01		D-26	Screw 6.35	1	151912-0-01	152808-1-01
D- 5-1-1	DV Bush	2	151935-0-00	D-5-1	D-27	Screw 5.95	1	013761-4-10	
D- 5-1-2	Power Cam	1		Power Cam Assembly	D-28	Starting Lever Shaft	1	151925-0-01	
D- 5-2	Bolt 6 x 8	1	018060-8-22	151933-0-01	D-29	Horizontal Feed Crank Ring	2	142628-0-01	
D- 5-3	Power Cam Stopper (A)	1	151940-0-01	D-5	D-30	Cap for Oil Inlet	1	111865-0-01	
D- 5-4	Power Cam Stopper (B) Assembly	1	151941-0-01	Power Cam Set	D-31	Starting Lever	1	151919-1-01	
D- 6	Power Pulley	1	153867-1-01	155523-0-01	D-32	Washer	1	110505-0-01	
D- 7	Stop Ring C35	1	048350-2-42		D-33	Stop Ring C11	1	048110-1-42	
D- 8	Ball Bearing 6003VV	1	072600-3-60		D-34	Starting Safety Lever	1	151920-0-01	
D- 9	Bearing Cover	1	151932-0-01		D-35	Washer	2	113431-0-02	
D-10	Screw 4.76	1	107231-0-02		D-36	Washer 2-5	2	028050-2-42	
D-11	P Pulley Shaft	1	151928-0-01		D-37	Bolt 4.76 x 14	2	017711-4-12	
D-12	Screw 5.95 x 6	1	014760-6-22		D-38	Nut 6.35	1	150556-0-01	
D-13	Screw	1	151954-0-01		D-39	Collar 13	1	151914-0-01	
D-14	Clutch Actuating Lever Shaft	1	151952-0-01		D-40	Screw 6.35	1	151913-0-01	
D-15	Screw 7.94 x 10	1	014821-0-22		D-41	Screw	1	154155-1-01	
D-16	Stop Ring C16	2	048160-1-42		D-42	Starting Lever Plate	1	155499-0-01	
D-17	Washer 16	2	151953-0-01		D-43	Washer 6	1	025060-2-32	
D-18-1	Clutch Actuating Lever	1		D-18	D-44	Nut 5.95	1	150553-0-01	
D-18-2	Screw 5.95 x 6	2	014760-6-22	Clutch Actuating	D-45	Spring Hook	1	110251-0-01	
D-18-3	Roller	2	151947-1-01	Lever Assembly	D-46	Spring Hook	1	151924-0-01	
D-18-4	Roller Stud	2	151948-0-01	151944-0-01	D-47	Spring (S)	1	155708-0-01	
D-19	Screw 5.95 x 6	1	014760-6-22		D-48	Chain Hook	1	151922-0-01	
D-20	Cap for Oil Inlet	1	111865-0-01		D-49	Bolt 5.95 x 22	1	017762-0-02	
D-21	Spring Hook	2	141472-0-02		D-50	Starting Lever Stopper	1	155500-0-01	
D-22	Spring	1	151951-0-01		D-51	Washer 6	2	025060-1-32	
D-23	Roller Stud Assembly	1	151949-0-01		D-52	Washer 2-6	2	028060-2-42	
D-24	Nut 6.35	1	150556-0-01		D-53	Bolt 6 x 16	2	018061-6-22	
					D-54	Washer 2-6	1	028060-2-42	

E. Presser Arm Mechanism

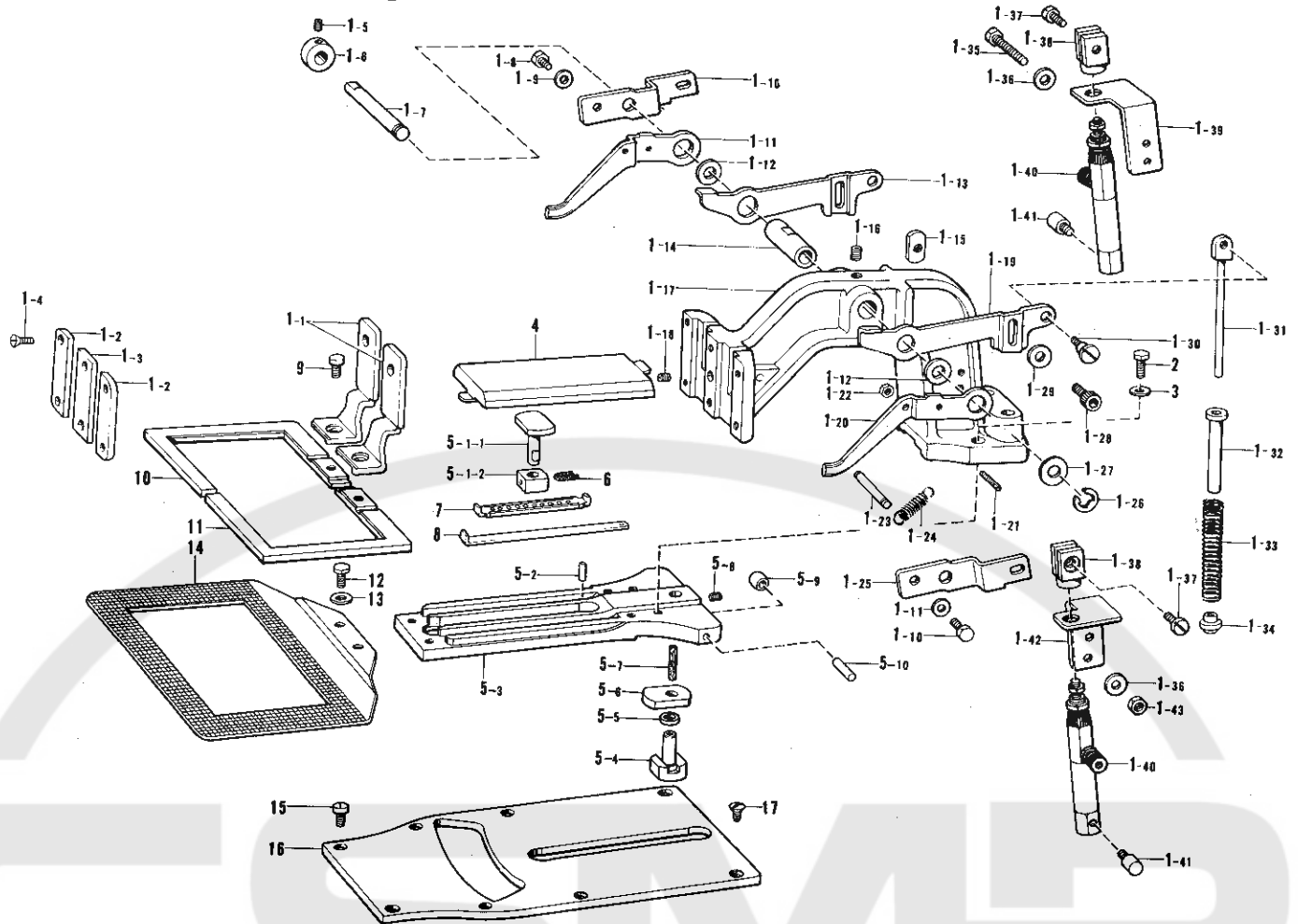

Ref. No.	Name of Parts	Q'ty	Parts No.	Assembly No.	Ref. No.	Name of Parts	Q'ty	Parts No.	Assembly No.
E-1- 1	Work Clamp (L)	2	153372-0-01	E-1 Presser Arm Assembly 155677-0-01	E- 1-36	Washer 5	4	025050-2-32	E-1 Presser Arm Assembly 155677-0-01
E-1- 2	Work Clamp Guide Bracket (A)	2	153369-0-01		E- 1-37	Roller Stud	2	110168-0-01	
E-1- 3	Work Clamp Guide Bracket (B)	1	153370-0-01		E- 1-38	Piston Rod Joint	2	155684-0-01	
E-1- 4	Screw 3.57	6	107038-0-03		E- 1-39	Cylinder Bracket L	1	155681-0-01	
E-1- 5	Screw 4.37 x 4	2	014680-4-22		E- 1-40	Cylinder	2	155683-0-01	
E-1- 6	Collar	1	139096-0-01		E- 1-41	Silencer	2	153269-0-01	
E-1- 7	Work Clamp Lever Shaft	1	155687-0-01		E- 1-42	Cylinder Bracket R	1	155682-0-01	
E-1- 8	Bolt 4.37 x 7	2	153403-0-02		E- 1-43	Nut 5	2	021500-1-02	
E-1- 9	Washer 4	2	025040-2-32		E- 2	Bolt 5.95 x 14	2	017761-4-12	
E-1-10	Presser Arm Lever L	1	155685-0-01		E- 3	Washer 6	2	025060-2-32	
E-1-11	Presser Arm Lever AL	1	155678-0-01		E- 4	Feed Guide Cover L	1	153391-0-01	
E-1-12	Thrust Ring	2	143591-0-01		E- 5- 1-1	Tack Regulator Shaft	1		
E-1-13	Presser Arm BL	1	153962-0-01		E- 5- 1-2	Slide Block	1		
E-1-14	Lever Shaft Bushing	1	153944-0-01		E- 5- 2	Roller	2	148133-0-01	
E-1-15	Presser Arm Lever Plate	2	153371-0-01		E- 5- 3	Feed Guide	1		
E-1-16	Screw 5.95 x 6	1	014760-6-22		E- 5- 4	Tack Width Regulator Assembly	1	156108-0-01	
E-1-17	Presser Arm	1	153364-0-02		E- 5- 5	Washer	1	156109-0-01	
E-1-18	Screw 4.37 x 6	1	014680-6-22		E- 5- 6	Slide Block	1	156077-0-01	
E-1-19	Presser Arm Lever BR	1	153947-0-01		E- 5- 7	Felt	1	156080-0-00	
E-1-20	Presser Arm Lever AR	1	155679-0-01		E- 5- 8	Screw 5.95	1	014760-6-22	
E-1-21	Spring Hook	2	110251-0-01		E- 5- 9	Roller	2		
E-1-22	Nut 3.57	2	021670-1-02		E- 5-10	Roller A3 x 17.8	2		
E-1-23	Spring Hook Pin	1	153957-0-01		E- 6	Wick	1	153926-0-01	
E-1-24	Spring (S)	2	155680-0-01		E- 7	Slide Plate	2	153384-0-01	
E-1-25	Work Clamp Lifter Lever R	1	155686-0-01		E- 8	Washer	2	153383-0-01	
E-1-26	Stop Ring E6	1	048060-3-42		E- 9	Bolt 4.37 x 5	2	017680-5-12	
E-1-27	Washer	1	100197-0-02		E-10	Work Clamp Presser (L)	1	157003-0-01	
E-1-28	Bolt 5 x 8	2	018500-8-22		E-11	Work Clamp Presser (R)	1	157002-0-01	
E-1-29	Washer	2	140407-0-02		E-12	Bolt 4.37 x 5	2	017680-5-12	
E-1-30	Screw 4.76	2	145478-0-01		E-13	Washer 4.37	2	025680-2-32	
E-1-31	Presser Spring Guide Rod	2	153570-0-01		E-14	Feed Plate	1	157001-0-01	
E-1-32	Presser Spring Collar	2	153567-0-00		E-15	Screw 4.37	6	145318-0-01	
E-1-33	Presser Spring	2	153569-0-01		E-16	Feed Guide Plate 100	1	156073-0-01	
E-1-34	Presser Spring Washer	2	152788-0-01		E-17	Screw 4.37	2	100032-0-03	
E-1-35	Bolt 5 x 20	2	018502-0-22						

F. Feed Mechanism (1)

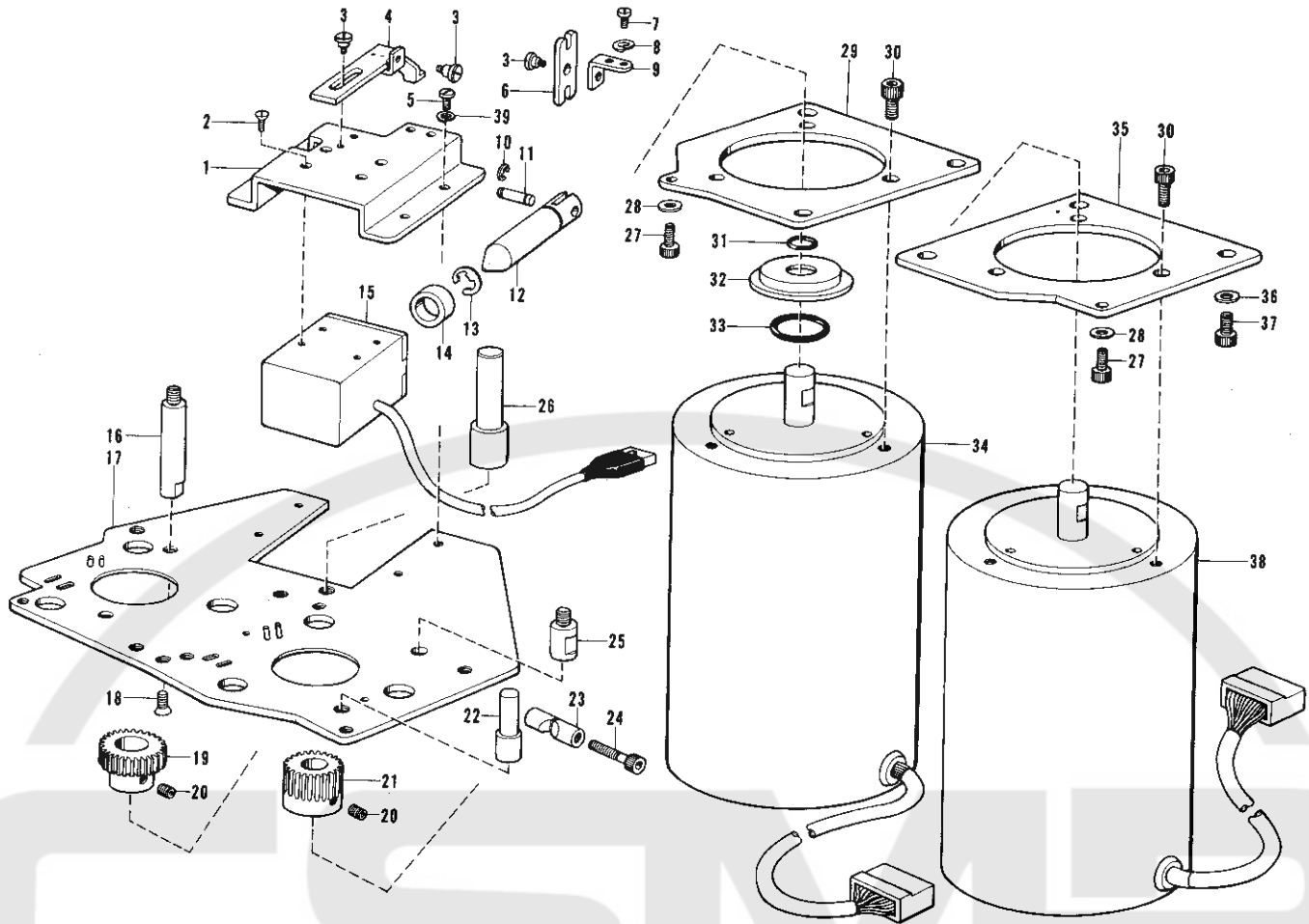

Ref. No.	Name of Parts	Q'ty	Parts No.	Assembly No.	Ref. No.	Name of Parts	Q'ty	Parts No.	Assembly No.
F-1	Solenoid Base	1	155607-0-01		F-21	Gear	1	155603-0-01	
F-2	Screw 4 x 8	4	003400-8-04		F-22	Motor Base Supporter Shaft S	1	155597-0-01	
F-3	Screw 4.37	3	155611-0-01		F-23	Sleeve	1	152725-0-00	
F-4	Clutch Lever Plate	1	155610-0-01		F-24	Bolt 6 x 30	1	018063-0-22	
F-5	Screw 4.37	4	009681-0-12		F-25	Motor Base Supporter S	1	155599-0-01	
F-6	Solenoid Lever	1	155609-0-01		F-26	Motor Base Supporter Shaft L	1	155596-0-01	
F-7	Screw 4.37	2	009681-0-12		F-27	Bolt 6 x 12	2	018061-2-22	
F-8	Washer 2-5	2	028050-2-42		F-28	Washer 6	2	025060-2-32	
F-9	Solenoid Lever Supporter	1	155608-0-01		F-29	Motor Base Supporter L	1	155601-0-01	
F-10	Stop Ring E4	2	048040-3-42		F-30	Bolt 8 x 12	6	018081-2-22	
F-11	Solenoid Lever Shaft	1	155612-0-01		F-31	Packing P14	2	081014-0-70	
F-12	Plunger	1	155613-0-01		F-32	Holder	2	155602-0-01	
F-13	Stop Ring E12	1	146103-0-01		F-33	Packing P24	2	081024-0-70	
F-14	Stopper	1	146104-0-00		F-34	Pulse Motor Assembly YS	1	155749-0-00	
F-15	Solenoid Assembly	1	155755-0-00		F-35	Motor Bracket R	1	155600-0-01	
F-16	Motor Base Supporter L	3	155598-0-01		F-36	Washer 8	6	025080-2-32	
F-17	Motor Base	1	155595-0-01		F-37	Bolt 8 x 12	6	018081-2-22	
F-18	Screw 6.35 x 18	6	003781-8-14		F-38	Pulse Motor Assembly XS	1	155747-0-00	
F-19	Gear	1	157247-0-01		F-39	Washer 2-5	4	028050-2-42	
F-20	Screw 6.35 x 6	4	014770-6-22						

F. Feed Mechanism (2)

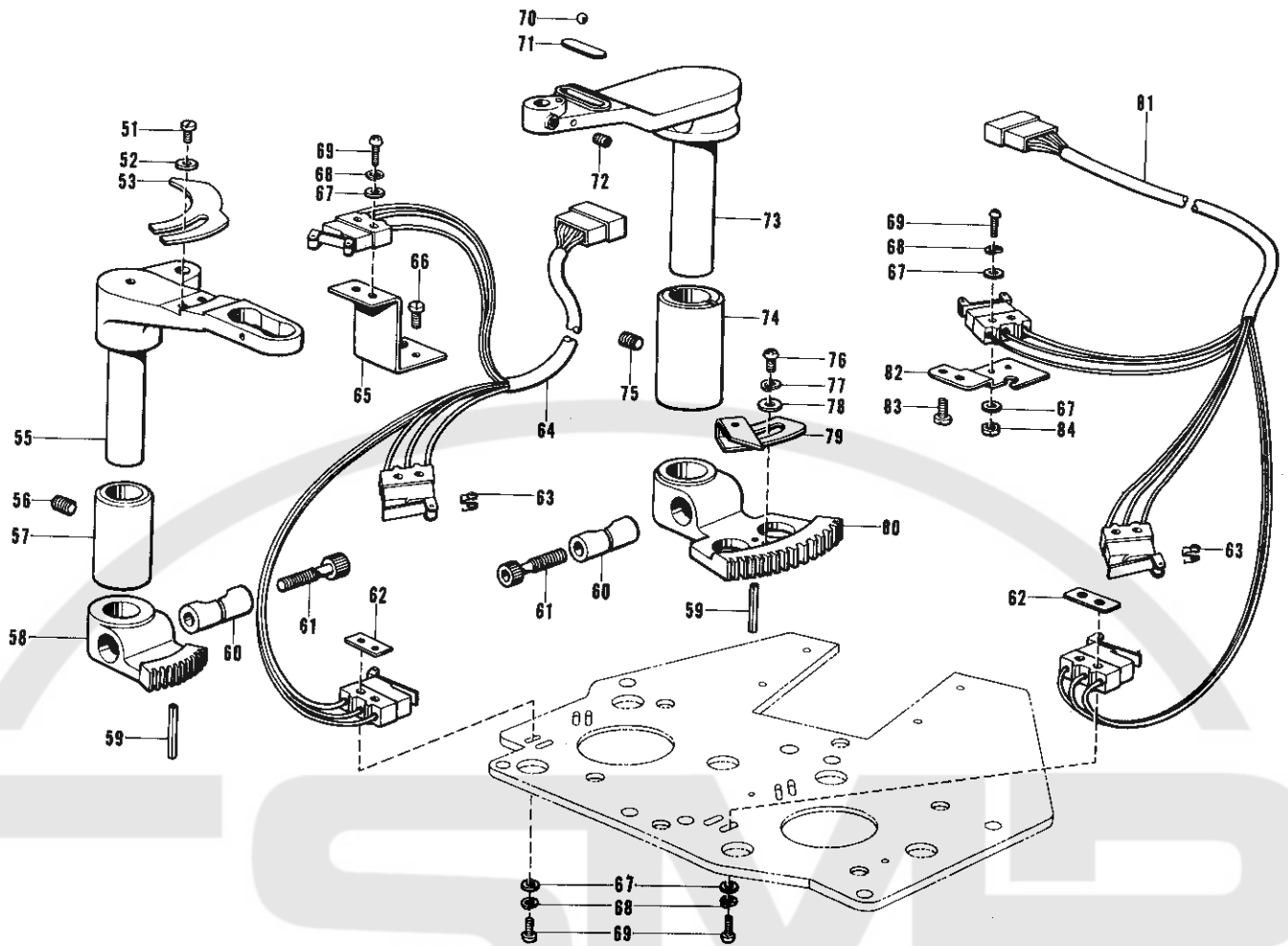

Ref. No.	Name of Parts	Q'ty	Parts No.	Assembly No.	Ref. No.	Name of Parts	Q'ty	Parts No.	Assembly No.
F-51	Screw 3.57	2	009670-6-12		F-68	Washer 2-2	12	028020-2-43	
F-52	Washer 4	2	025040-1-32		F-69	Screw 2 x 14	12	002021-4-05	
F-53	Y-Position Dog	1	155618-0-01		F-70	Steel Ball 3/16	1	071047-6-50	
F-55	Tack Width Lever S	1	157245-0-01		F-71	Washer	1	153393-0-01	
F-56	Screw 5.95 x 6	1	014760-6-22		F-72	Screw 5.95	1	152718-0-01	
F-57	Bushing	1	155591-0-01		F-73	Tack Length Lever 100	1	153347-1-01	
F-58	Driving Gear	1	157246-0-01		F-74	Bushing	1	152745-0-01	
F-59	Spring Pin AW25	2	047202-5-42		F-75	Screw 5.95 x 6	1	014760-6-22	
F-60	Sleeve	2	152725-0-00		F-76	Screw 4.76 x 10	1	009711-0-12	
F-61	Bolt 6 x 30	2	018063-0-22		F-77	Washer	1	028050-2-42	
F-62	Switch Supporter	4	155819-0-00		F-78	Washer 5	1	025050-2-32	
F-63	Spring	6	157210-0-01		F-79	X-Position Dog	1	155615-0-01	
F-64	Micro Switch Y Assembly	1	155739-0-00		F-80	Driving Gear	1	155606-0-01	
F-65	Y-Position Switch Bracket	1	155617-0-01		F-81	Micro Switch X Assembly	1	155735-0-00	
F-66	Screw 3.57	2	009670-6-12		F-82	X-Position Switch Bracket	1	155614-0-01	
F-67	Washer 2	14	025020-2-35		F-83	Screw 3.57	2	009670-6-12	
					F-84	Nut 2	2	021020-1-03	

G. Vertical Shaft Mechanism

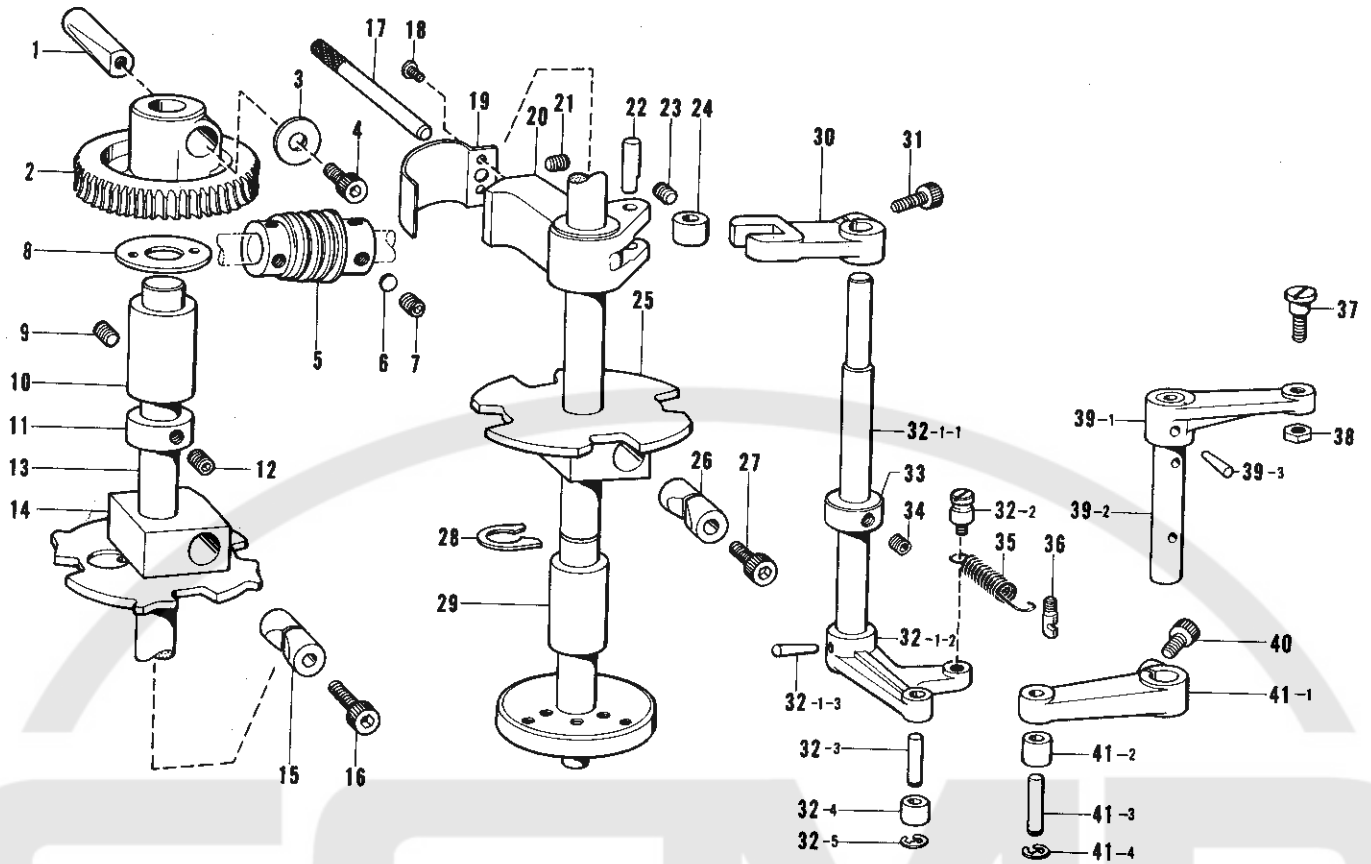

Ref. No.	Name of Parts	Q'ty	Parts No.	Assembly No.	Ref. No.	Name of Parts	Q'ty	Parts No.	Assembly No.
G-1	Sleeve	1	152709-0-00		G-27	Bolt 6 x 30	1	018063-0-22	
G-2	Worm Wheel	1	152708-0-00		G-28	Stop Ring	1	152723-0-01	
G-3	Washer	1	152710-0-01		G-29	Vertical Shaft Bushing (D)	1	152712-0-01	
G-4	Bolt 6 x 20	1	018062-0-22		G-30	Roller Holder Lever	1	152734-0-01	
G-5	Worm	1	152707-0-01		G-31	Bolt 6 x 16	1	018061-6-22	
G-6	Washer	1	147151-0-00		G-32-1-1	Roller Holder Lever Shaft	1		G-32-1 Roller Holder Cam Lever Assembly 153332-0-01
G-7	Screw 5.95	6	152718-0-01		G-32-1-2	Roller Holder Cam Lever	1		
G-8	Washer	1	152713-0-01		G-32-1-3	Taper Pin 3 x 20	1	046302-0-20	
G-9	Screw 5.95 x 6	1	014760-6-22		G-32-2	Screw	1	155337-0-01	G-32 Roller Holder Lever Assembly 152735-1-01
G-10	Vertical Shaft Bushing (U)	1	152711-0-00		G-32-3	Pin	1	152739-0-01	
G-11	Collar	1	141816-0-01		G-32-4	Roller	1	153195-0-01	
G-12	Screw 6.35 x 6	2	014770-6-22		G-32-5	Stop Ring E4	1	048040-3-42	
G-13	Vertical Shaft Assembly	1	152715-0-01		G-33	Collar	1	110027-0-01	
G-14	Clutch Cam	1	152729-0-01		G-34	Screw 5.95 x 6	2	014760-6-22	
G-15	Sleeve	1	152725-0-00		G-35	Spring S	1	155694-0-01	
G-16	Bolt 6 x 30	1	018063-0-22		G-36	Spring Hook	1	141334-0-01	
G-17	Emergency Stop Lever	1	152733-0-01		G-37	Screw 5.95	1	151907-0-01	
G-18	Screw 3.57 x 4	2	009670-4-12		G-38	Nut 5.95	1	150553-0-01	
G-19	Cover	1	153141-0-01		G-39-1	Clutch Actuating Lever	1		G-39 Clutch Actuating Lever Shaft 151915-0-01
G-20	Roller Holder	1	152731-0-01		G-39-2	Clutch Actuating Lever Shaft	1		
G-21	Screw 4.76	1	013710-7-12		G-39-3	Pin	1	107030-0-01	
G-22	Pin	1	152732-0-01		G-40	Bolt 6 x 20	1	018062-0-22	
G-23	Screw 4.76	1	013710-7-12		G-41-1	Clutch Cam Lever	1		G-41 Clutch Cam Lever Assembly 151939-0-01
G-24	Roller	1	152914-0-01		G-41-2	Roller	1	152914-0-01	
G-25	Knife Cam	1	152730-0-01		G-41-3	Roller Stud	1	152913-0-01	
G-26	Sleeve	1	152725-0-00		G-41-4	Stop Ring E4	1	048040-3-42	

H. Work Clamp and Thread Wiper Mechanism

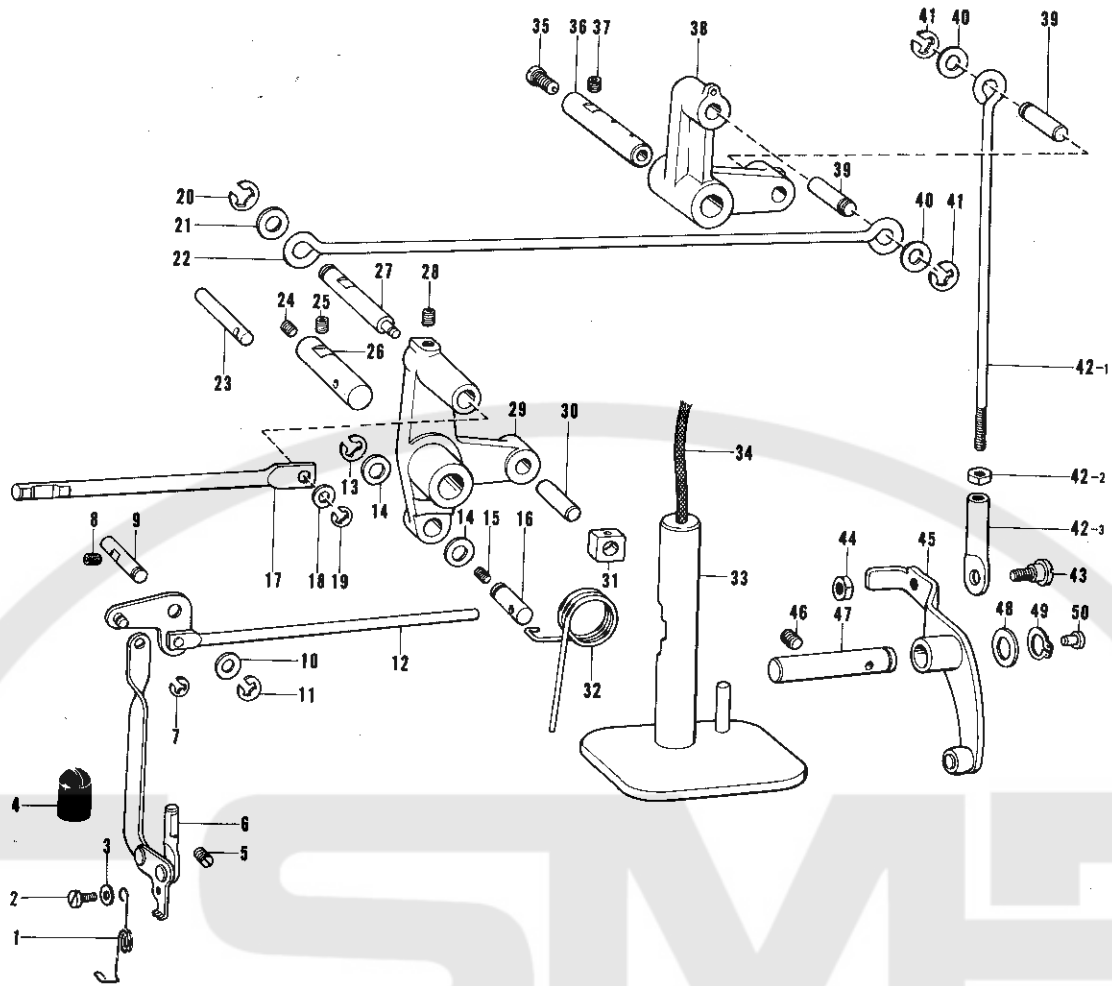

Ref. No.	Name of Parts	Q'ty	Parts No.	Assembly No.	Ref. No.	Name of Parts	Q'ty	Parts No.	Assembly No.
H-1	Thread Wiper	1	152828-0-01		H-27	Work Clamp Lifter Rod Shaft A	1	152802-0-01	
H-2	Screw 3.57	1	009670-5-12		H-28	Screw 5.95 x 6	1	014760-6-22	
H-3	Washer 3.5	1	025350-1-32		H-29	Work Clamp Lifter Lever	1	152798-0-01	
H-4	Oil Cap	1	152827-0-01		H-30	Tack Length Slide Block Pin	1	152744-0-01	
H-5	Screw 4.76	1	013710-7-12		H-31	Needle Bar Guide Slide Block	1	102630-0-01	
H-6	Thread Wiper Link Assembly	1	152823-0-01		H-32	Spring	1	152800-2-01	
H-7	Stop Ring E3	1	048030-3-42		H-33	Work Clamp Lifter Plate Assembly	1	152794-0-01	
H-8	Screw 4.37 x 6	1	014680-6-22		H-34	Wick 4 x 4	1	152968-0-01	
H-9	Thread Wiper Shaft	1	152822-0-01		H-35	Screw 7.14	1	146141-0-01	
H-10	Washer 6.35	1	025770-2-32		H-36	Connecting Lever Shaft T	1	154183-0-01	
H-11	Stop Ring E4	1	048040-3-42		H-37	Screw 5.95 x 6	1	014760-6-22	
H-12	Thread Wiper Rod Assembly	1	152816-0-01		H-38	Lifting Lever Shaft	1	152805-0-01	
H-13	Stop Ring E6	1	048060-3-42		H-39	Connecting Lever Shaft B	2	152806-0-01	
H-14	Washer	2	116629-0-01		H-40	Washer	2	107153-0-02	
H-15	Screw 4.37 x 6	1	014680-6-22		H-41	Stop Ring E6	2	048060-3-42	
H-16	Thread Wiper Rod Shaft	1	152815-0-01		H-42-1	Connecting Rod	1	154332-0-01	H-42 Connecting Rod Assembly 152808-1-01
H-17	Tension Release Pin	1	152874-0-01		H-42-2	Nut 6.35	1	150555-0-01	
H-18	Washer	1	140208-0-01		H-42-3	Joint	1	154333-0-01	
H-19	Stop Ring E4	1	048040-3-42		H-43	Screw 6.35	1	141583-0-01	
H-20	Stop Ring E6	1	048060-3-42		H-44	Nut 6.35	1	150555-0-01	
H-21	Washer	1	107153-0-02		H-45	Connecting Lever	1	152811-0-01	
H-22	Work Clamp Lifter Rod A	1	152803-0-01		H-46	Screw 5.95 x 6	1	014760-6-22	
H-23	Pin	1	152801-0-01		H-47	Driving Shaft	1	152924-0-01	
H-24	Screw 5.95	1	013760-6-12		H-48	Horizontal Feed Crank Ring	1	142628-0-01	
H-25	Screw 5.95 x 6	1	014760-6-22		H-49	Stop Ring C11	1	048110-1-42	
H-26	Work Clamp Lifter Lever Shaft	1	152799-0-01		H-50	Cap for Oil Inlet	1	111865-0-01	

J. Thread Trimming and Thread Nipper Mechanism

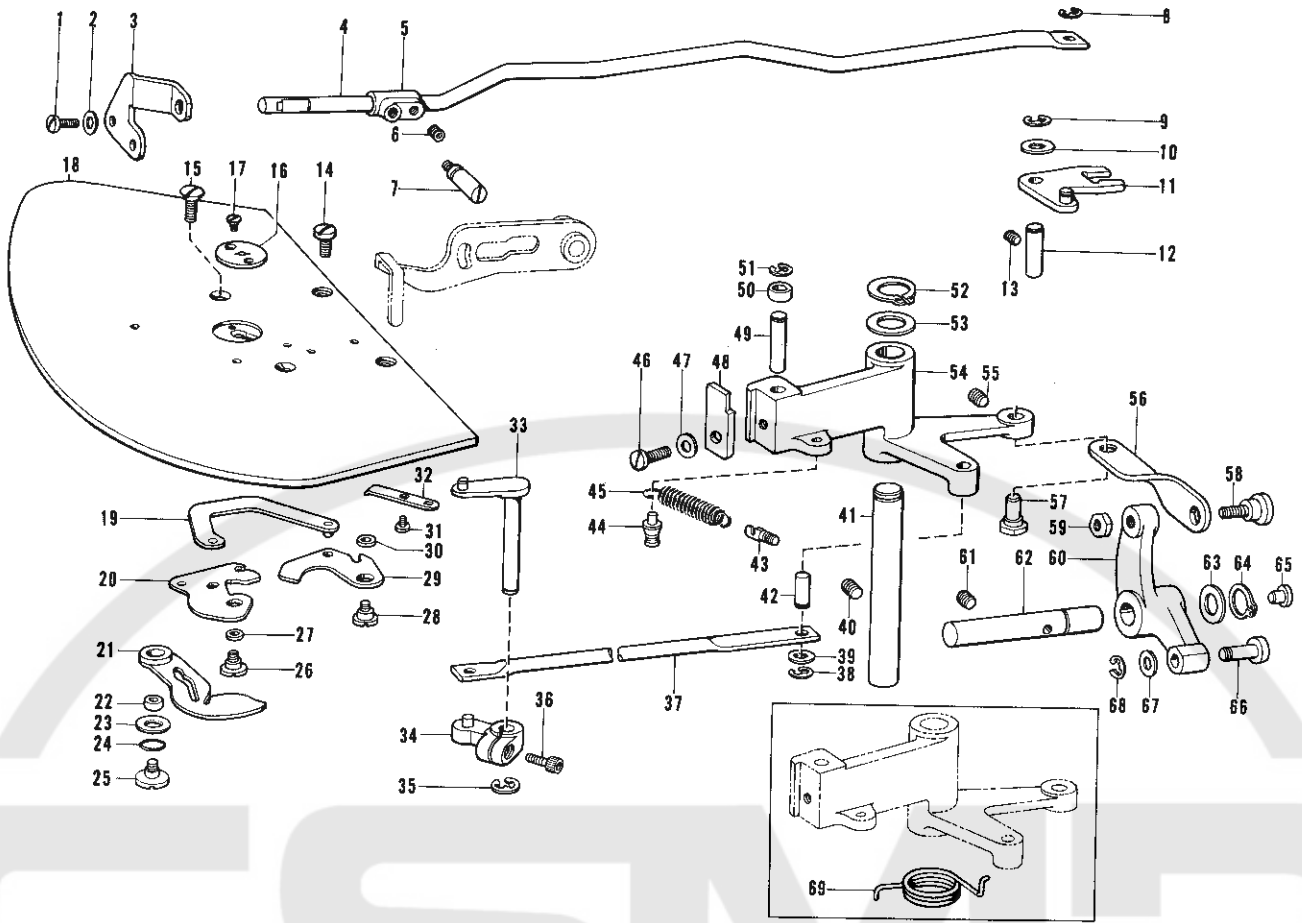

Ref. No.	Name of Parts	Q'ty	Parts No.	Assembly No.	Ref. No.	Name of Parts	Q'ty	Parts No.	Assembly No.
J-1	Screw 3.57	2	009671-0-12		J-36	Bolt 4.37 x 10	1	018681-0-22	
J-2	Washer 3.5	2	025350-3-32		J-37	Connecting Rod	1	152892-0-01	
J-3	Tension Release Bar Plate	1	152926-0-01		J-38	Stop Ring E4	1	048040-3-42	
J-4	Tension Release Bar	1	152925-1-01		J-39	Washer	1	140208-0-01	
J-5	Thread Take-up Guide	1	152886-0-01		J-40	Screw 5.95 x 6	1	014760-6-22	
J-6	Screw 4.37 x 4	1	014680-4-22		J-41	Shaft	1	152916-0-01	
J-7	Guide Stud	1	152887-0-01		J-42	Pin	1	152919-0-01	
J-8	Stop Ring E4	1	048040-3-42		J-43	Spring Hook	1	141334-0-01	
J-9	Stop Ring E5	1	048050-3-42		J-44	Spring Hook	1	154789-0-01	
J-10	Washer 6.35	1	025770-2-32		J-45	Cam Lever Spring	1	154788-0-01	
J-11	Tension Release Lever Assembly	1	152988-0-01		J-46	Screw 5.95 x 14	1	009761-4-12	
J-12	Tension Release Lever Shaft	1	152929-0-01		J-47	Washer 6	1	025060-1-32	
J-13	Screw 5.95 x 6	1	014760-6-22		J-48	Cam Lever Claw	1	152915-0-01	
J-14	Screw 4.37	2	153208-0-01		J-49	Roller Stud	1	152913-0-01	
J-15	Screw 4.37	2	100032-0-03		J-50	Roller	1	152914-0-01	
J-16	Needle Hole Plate	1			J-51	Stop Ring E4	1	048040-3-42	
J-17	Screw 2.38	2	100360-0-03		J-52	Stop Ring C12	1	048120-1-42	
J-18	Needle Plate	1	153424-0-01		J-53	Washer	1	152917-0-01	
J-19	Knife Connecting Rod Assembly	1	152897-1-01		J-54	Cam Lever	1	152912-0-01	
J-20	Movable Knife Assembly	1			J-55	Screw 5.95 x 6	1	014760-6-22	
J-21	Thread Retainer	1			J-56	Thread Trimming Link	1	152921-0-01	
J-22	Collar	1	153597-0-01		J-57	Stud	1	152920-0-01	
J-23	Washer	1	153596-0-01		J-58	Screw 5.95	1	151907-0-01	
J-24	Packing P8	1	081008-0-70		J-59	Nut 5.95	1	150553-0-01	
J-25	Screw 4.37	1	153598-0-01		J-60	Thread Trimming Lever	1	152922-0-01	
J-26	Screw 4.37	1	152904-0-01		J-61	Screw 5.95 x 6	1	014760-6-22	
J-27	Collar	1	153219-0-01		J-62	Driving Shaft	1	153482-0-01	
J-28	Screw 4.37	1	153222-0-01		J-63	Horizontal Feed Crank Ring	1	142628-0-01	
J-29	Knife Arm C	1	152981-0-01		J-64	Stop Ring C11	1	048110-1-42	
J-30	Collar	1	153220-0-01		J-65	Cap for Oil Inlet	1	111865-0-01	
J-31	Screw 2.38	2	111140-0-01		J-66	Roller	1	152923-0-01	
J-32	Fixed Knife	1	152905-0-01		J-67	Washer	1	112468-0-01	
J-33	Thread Trimming Arm B	1	152893-1-01		J-68	Stop Ring E5	1	048050-3-42	
J-34	Thread Trimming Arm A Assembly	1	152896-0-01		J-69	Spring	1		
J-35	Stop Ring E5	1	048050-3-42						

K. Bobbin Winder and Threading Mechanism

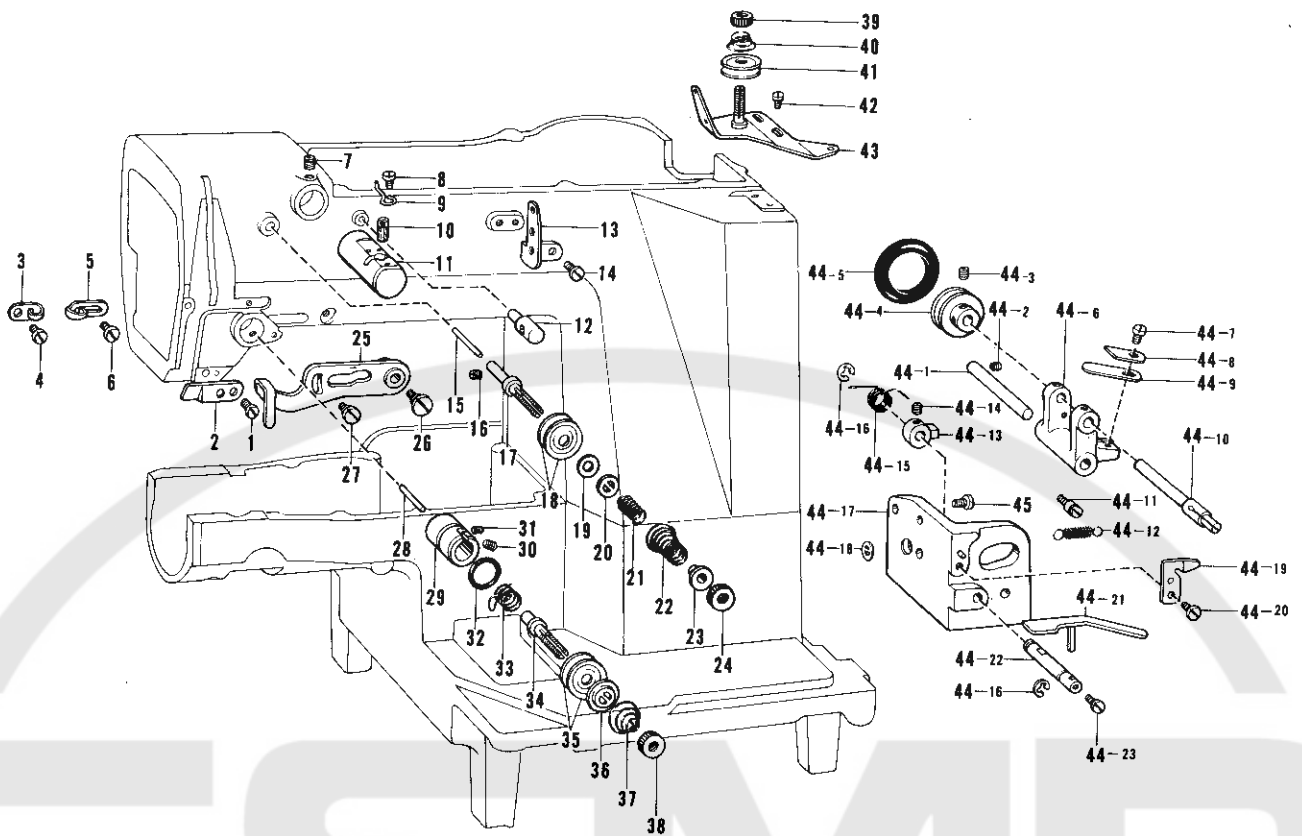

Ref. No.	Name of Parts	Q'ty	Parts No.	Assembly No.	Ref. No.	Name of Parts	Q'ty	Parts No.	Assembly No.
K- 1	Screw 4.76	1	009710-7-12		K-35	Tension Disc	2	145446-0-01	
K- 2	Arm Thread Guide	1	152869-0-01		K-36	Presser for Tension Disc	1	100134-0-01	
K- 3	Arm Thread Guide	1	152870-0-01		K-37	Tension Spring	1		
K- 4	Screw 3.57	1	009670-6-12		K-38	Tension Control Nut	1	100136-0-01	
K- 5	Arm Thread Guide	1	113316-0-01		K-39	Tension Control Nut	1	100136-0-01	
K- 6	Screw 3.57	1	112751-0-03		K-40	Tension Spring	1	104525-0-01	
K- 7	Screw 5.95	1	013760-6-12		K-41	Tension Disc	2	145446-0-01	
K- 8	Screw 3.57	1	009670-4-12		K-42	Screw 4.37	2	009681-0-12	
K- 9	Needle Cooler Thread Guide	1	152884-0-01		K-43	Lower Thread Tension Bracket Assembly	1	152945-0-01	
K-10	Felt 7 x 15.5	1	152883-0-00		K-44- 1	Bobbin Winder Lever Shaft	1	152934-0-01	
K-11	Needle Cooler Body	1	152881-0-01		K-44- 2	Screw 4.37	1	102716-0-04	
K-12	Upper Thread Guide Bar	1	153049-0-01		K-44- 3	Screw 4.37	2	100716-0-04	
K-13	Thread Retainer	1	152889-0-01		K-44- 4	Bobbin Winder Wheel	1	154528-0-01	
K-14	Screw 3.57	2	009670-6-12		K-44- 5	Rubber Ring	1	120448-0-01	
K-15	Tension Release Pin	1	152876-0-01		K-44- 6	Bobbin Winder Lever	1	152984-0-01	
K-16	Screw 4.37	1	151601-0-02		K-44- 7	Screw 3.57 x 7	1	009670-7-12	
K-17	Tension Stud	1	152875-0-01		K-44- 8	Washer	1	152937-0-01	
K-18	Tension Disc	2	145446-0-01		K-44- 9	Plate Spring	1	152936-0-01	
K-19	Washer	1	153138-0-01		K-44-10	Bobbin Winder Shaft	1	152933-0-01	
K-20	Tension Disc Washer	1	152877-0-01		K-44-11	Sustainer	1	141550-0-01	
K-21	Tension Spring	1	152878-0-01		K-44-12	Spring	1	152939-0-01	
K-22	Tension Spring	1	152879-1-01		K-44-13	Claw for Bobbin Winder	1	142566-0-01	
K-23	Washer	1	152880-0-01		K-44-14	Screw 4.37	2	151601-0-01	
K-24	Tension Control Nut	1	100136-0-01		K-44-15	Spring	1	152941-0-01	
K-25	Thread Take-up Lever	1	152888-0-01		K-44-16	Stop Ring E5	2	048050-3-42	
K-26	Screw 6.35	1	141528-0-03		K-44-17	Bobbin Winder Bracket	1	152983-0-01	
K-27	Screw 4.76	1	115077-0-03		K-44-18	Spring Hook	1	115138-0-01	
K-28	Tension Release Pin	1	152873-0-01		K-44-19	Knife	1	152938-0-01	
K-29	Tension Bracket	1	152872-0-01		K-44-20	Screw 4.37 x 7	1	009680-7-12	
K-30	Screw 5.95	1	103950-0-02		K-44-21	Bobbin Presser	1	152935-0-01	
K-31	Screw 3.57	1	100402-0-04		K-44-22	Claw Stud for Bobbin Winder	1	152940-0-01	
K-32	Packing	1	114294-0-01		K-44-23	Screw 3.57 x 7	1	009670-7-12	
K-33	Thread Take-up Spring	1			K-45	Screw 5.95 x 14	2	009761-4-12	
K-34	Tension Stud	1	100398-0-01						

K-44
Bobbin Winder
Assembly
152982-1-01

L. Oil Pan

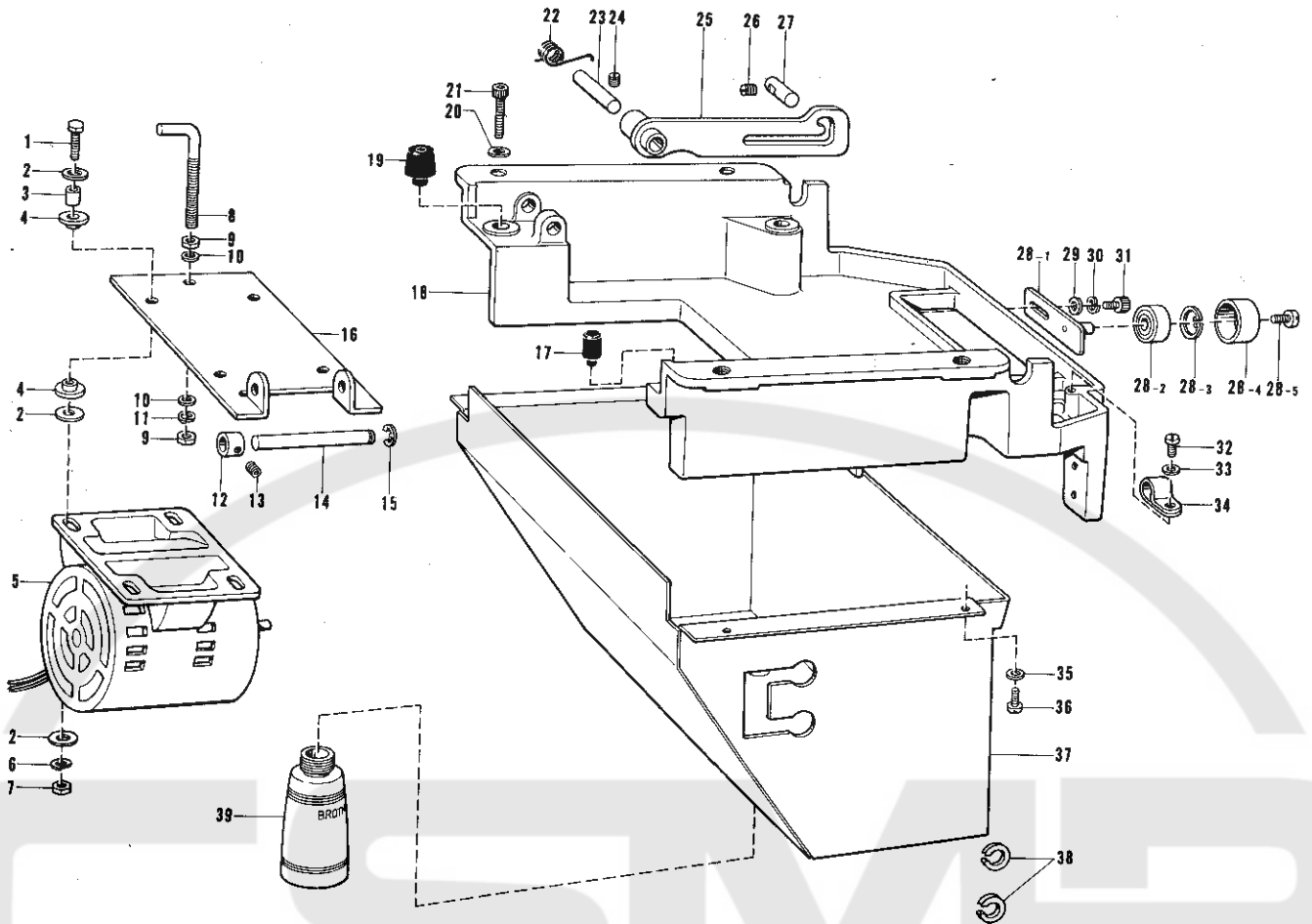

Ref. No.	Name of Parts	Q'ty	Parts No.	Assembly No.	Ref. No.	Name of Parts	Q'ty	Parts No.	Assembly No.
L-1	Bolt 6 x 25	4	017062-5-03		L-23	Head Supporter Lever Shaft	1	152858-0-01	
L-2	Washer 7.14	12	025800-3-33		L-24	Screw 4.76	1	013719-4-12	
L-3	Cushion Collar	4	152863-0-01		L-25	Head Supporter Lever	1	155709-0-01	
L-4	Cushion	8	152864-0-00		L-26	Screw 5.95	1	013760-6-12	
L-5	Three Phase Motor	1			L-27	Pin	1	152866-0-01	
L-6	Washer 2-6	4	028060-2-42		L-28-1	Tension Pulley Plate	1		
L-7	Nut 6	4	021060-1-02		L-28-2	Ball Bearing 6201 VV	1		
L-8	Bolt M10	1	152865-0-01		L-28-3	Stop Ring C32	1	048320-2-42	L-28
L-9	Nut 10	2	021100-2-02		L-28-4	Tension Pulley	1		Tension Pulley
L-10	Washer 10	2	025100-1-32		L-28-5	Screw 6.35	1	141860-0-01	Assembly
L-11	Washer 2-10	1	028100-2-42		L-29	Washer 8	1	025080-2-32	152852-1-01
L-12	Collar	1	146741-0-00		L-30	Washer 2-8	1	028080-2-42	
L-13	Screw 6.35 x 6	1	014770-6-22		L-31	Bolt 8 x 12	1	018081-2-22	
L-14	Motor Base Plate Shaft S	1	155587-0-01		L-32	Screw 4 x 10	1	002401-0-03	
L-15	Stop Ring C10	2	048100-1-42		L-33	Washer 4	1	025040-2-33	
L-16	Motor Base Plate	1	152861-1-01		L-34	Cord Holder	1	515907-0-00	
L-17	Bed Cushion S	1	155586-0-01		L-35	Washer 4	4	025040-2-32	
L-18	Oil Pan U	1	155585-0-01		L-36	Screw 4 x 8	4	007400-8-12	
L-19	Bed Cushion	3	152860-0-01		L-37	Oil Pan D	1	155707-0-01	
L-20	Washer 5	4	025050-1-32		L-38	Bushing	2	157005-1-01	
L-21	Bolt 4 x 50	4	018505-0-22		L-39	Oiler	1	114486-0-01	
L-22	Head Supporter Lever Spring	1	152859-0-01						

M. Lubrication

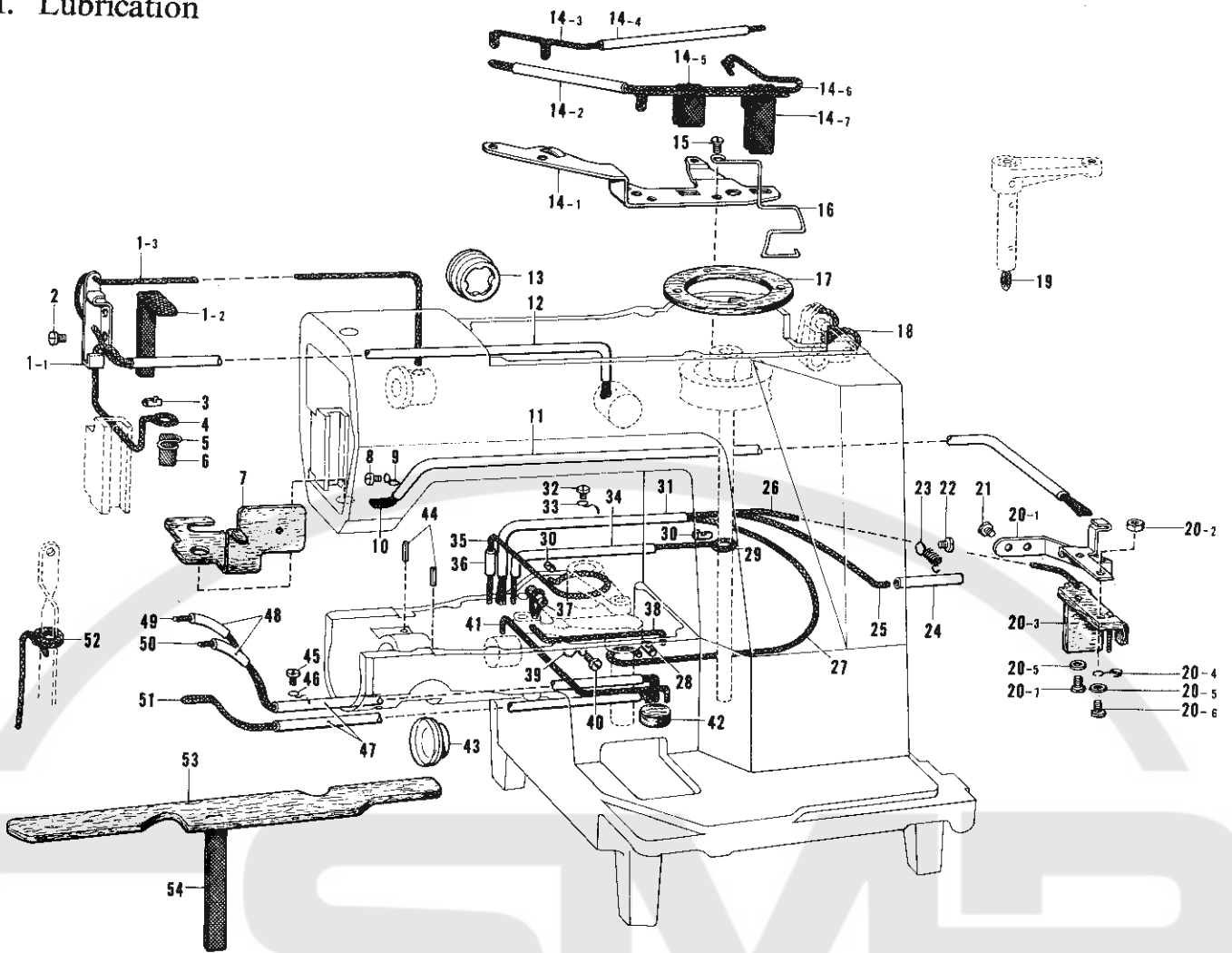

Ref. No.	Name of Parts	Q'ty	Parts No.	Assembly No.	Ref. No.	Name of Parts	Q'ty	Parts No.	Assembly No.
M- 1-1	Wick Supporter	1	152959-0-01	M-1 Wick Supporter Assembly 152958-0-01	M-21	Screw 3.57 x 6	2	009670-6-12	
M- 1-2	Wick	1	152955-0-01		M-22	Screw 4.37 x 8	1	009680-8-12	
M- 1-3	Wick 4 x 4	1	152956-0-01		M-23	Tube Supporter	1	152978-0-01	
M- 2	Screw 4.37 x 6	1	009680-6-12	M-24	Oil Tube	1	148735-0-01		
M- 3	Wick Supporter	1	104567-0-01	M-25	Wick 4 x 4	1	153922-0-01		
M- 4	Wick 4 x 4	1	152956-0-01	M-26	Wick 4 x 4	1	152963-0-01		
M- 5	Wick Supporter	1	152962-0-01	M-27	Wick 4 x 4	1	153922-0-01		
M- 6	Wick	1	152960-0-01	M-28	Wick Supporter	1	104567-0-01		
M- 7	Felt	1	153530-0-01	M-29	Wick 6 x 6	1	152964-0-01		
M- 8	Screw 3.57	1	009670-5-12	M-30	Wick Supporter	2	104567-0-01		
M- 9	Cord Supporter	1	117150-0-01	M-31	Oil Tube	1	148921-0-00		
M-10	Wick	1	152992-0-01	M-32	Screw 3.57	1	009670-5-12		
M-11	Oil Tube	1	146375-0-00	M-33	Cord Supporter	1	152969-0-01		
M-12	Oil Tube	1	144694-0-01	M-34	Oil Tube	1	147745-0-00		
M-13	Oil Guage Window	1	152948-0-01	M-35	Wick 4 x 4	1	152974-0-01		
M-14-1	Wick Supporter	1	152950-0-01	M-36	Oil Tube	1	148735-0-01		
M-14-2	Oil Tube	1	140423-0-00	M-37	Felt	1	153924-0-01		
M-14-3	Wick 6 x 6	1	153919-0-01	M-38	Wick 4 x 4	1	153921-0-01		
M-14-4	Oil Tube	1	147745-0-00	M-39	Cord Supporter	1	117150-0-01		
M-14-5	Felt	1	152952-0-01	M-40	Screw 3.57	1	009670-5-12		
M-14-6	Wick 6 x 6	1	153918-0-01	M-41	Wick 4 x 4	1	152973-0-01		
M-14-7	Felt	1	152951-0-01	M-42	Felt	1	113006-0-01		
M-15	Screw 4.37 x 10	2	009681-0-12	M-43	Oil Guage Window	1	152948-0-01		
M-16	Wick Supporter	1	153528-0-01	M-44	Pin	2	047251-6-40		
M-17	Felt	1	153529-0-01	M-45	Screw 3.57	1	009670-5-12		
M-18	Wick 6 x 6	1	153927-0-01	M-46	Cord Supporter	1	152969-0-01		
M-19	Wick 6 x 6	1	152980-0-01	M-47	Oil Tube	2	140423-0-00		
M-20-1	Felt Supporter	1	152966-0-01	M-48	Oil Tube	2	148735-0-01		
M-20-2	Nut 3.57	1	021670-2-02	M-49	Wick 4 x 4	1	152972-0-01		
M-20-3	Felt	1	152967-0-01	M-50	Wick 4 x 4	1	153920-0-01		
M-20-4	Tube Stopper C	1	141692-0-01	M-51	Wick 4 x 4	1	152971-0-01		
M-20-5	Washer 3.5	3	025350-3-32	M-52	Wick 4 x 4	1	152973-0-01		
M-20-6	Screw 3.57 x 14	1	009671-4-12	M-53	Felt	1	153531-0-01		
M-20-7	Screw 3.57 x 8	2	009670-8-12	M-54	Wick	1	153562-0-01		

N. Synchronizer

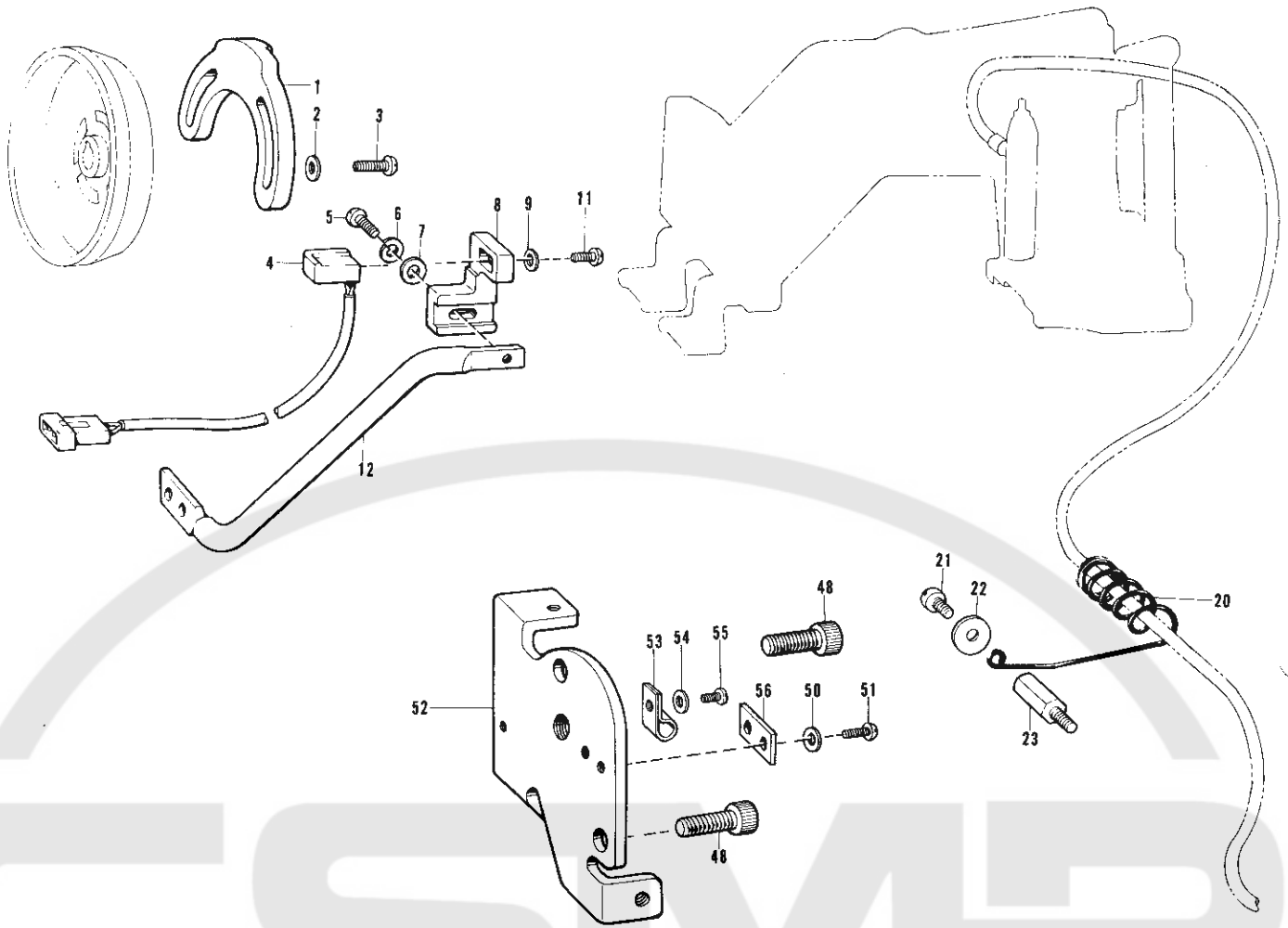

Ref. No.	Name of Parts	Q'ty	Parts No.	Assembly No.	Ref. No.	Name of Parts	Q'ty	Parts No.	Assembly No.
N- 1	MG Holder Assembly	1	155621-0-00		N-21	Screw 4.76	1	009710-7-12	
N- 2	Washer 5	2	025050-2-32		N-22	Washer 5	1	025050-2-32	
N- 3	Screw 4.76	2	009711-2-12		N-23	Bolt 4.76	1	153959-0-01	
N- 4	Synchronizer Assembly	1	155745-0-00		N-48	Bolt 8 x 15	2	151163-0-01	
N- 5	Screw 4.76	1	009711-2-12		N-50	Washer 5	2	025050-2-32	
N- 6	Washer 2-5	1	028050-2-42		N-51	Screw 4.76 x 10	2	009711-0-12	
N- 7	Washer 5	1	025050-2-32		N-52	Starting Lever Bracket	1	155592-0-01	
N- 8	Hole IC Holder	1	155619-0-01		N-53	Cord Holder	1	149547-0-00	
N- 9	Washer 4	1	025040-3-32		N-54	Washer 4	1	025040-2-33	
N-11	Screw 4 x 10	1	002401-0-03		N-55	Screw 3.57 x 6	1	009670-6-12	
N-12	Hole IC Supporter	1	155620-0-01		N-56	Washer	1	157206-0-01	
N-20	Wire Holder (L)	1	153958-0-01						

P. Intermittent Presser Foot Mechanism

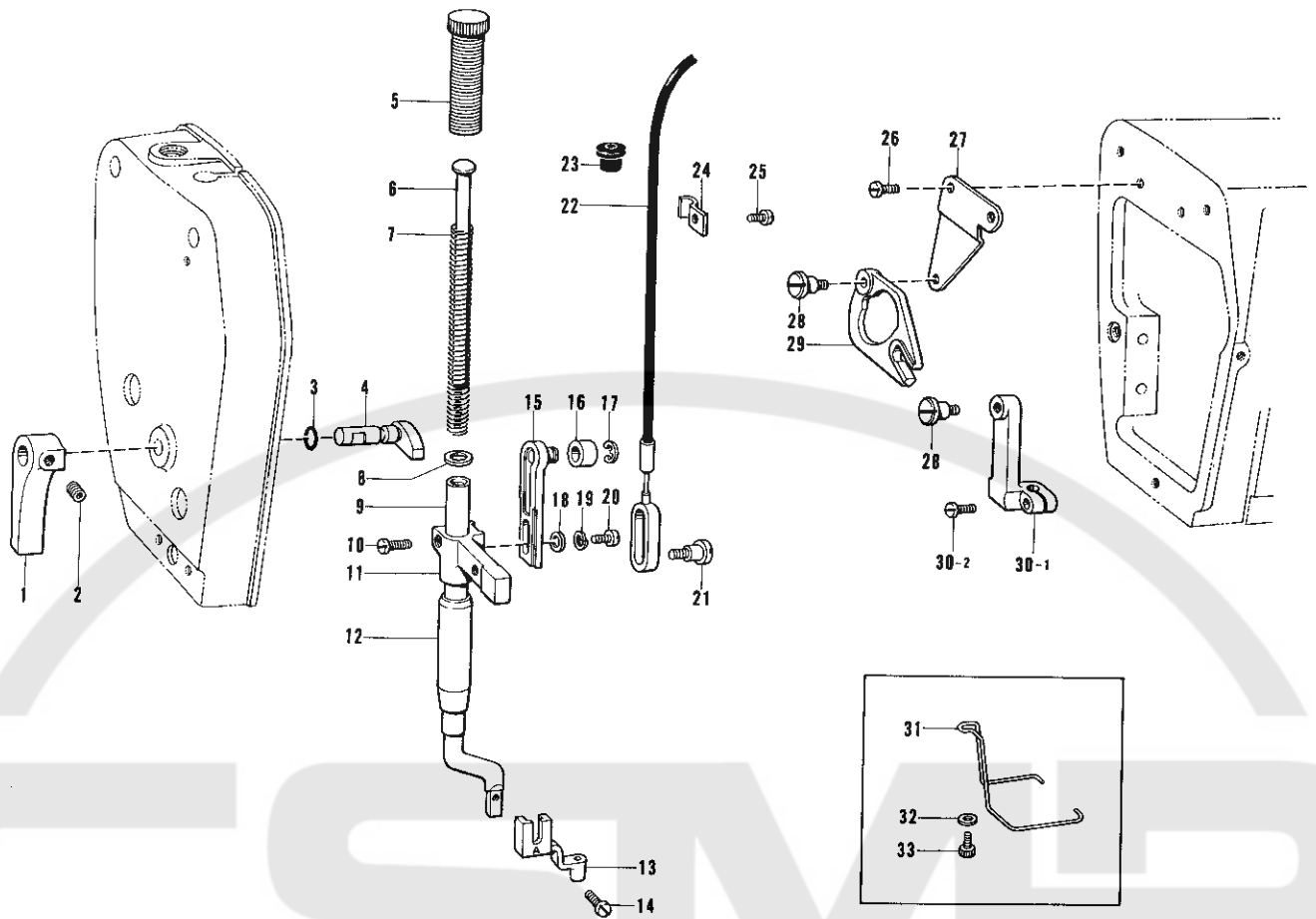

Ref. No.	Name of Parts	Q'ty	Parts No.	Assembly No.	Ref. No.	Name of Parts	Q'ty	Parts No.	Assembly No.
P- 1	Presser Bar Lifter	1	145482-0-01		P-19	Washer 2-4.37	2	028680-2-42	
P- 2	Screw 4.76	1	013710-5-12		P-20	Screw 4.37 x 10	2	009680-8-12	
P- 3	Packing	1	081001-6-70		P-21	Screw 4.37	1	407670-0-01	
P- 4	Presser Bar Crank S	1	156040-0-01		P-22	Wire Assembly	1	156046-0-01	
P- 5	Screw	1	141207-0-01		P-23	Bushing	1	146080-0-00	
P- 6	Presser Spring Bar	1	141208-0-01		P-24	Wire Holder	1	156041-0-01	
P- 7	Presser Spring (C)	1	154115-0-01		P-25	Screw 3.57 x 10	1	009670-8-12	
P- 8	Presser Spring Washer	1	140407-0-01		P-26	Screw 4.76 x 8	2	009710-8-12	
P- 9	Presser Bar	1	156039-0-01		P-27	Presser Cam Bracket	1	155742-0-01	
P-10	Screw 4.37	1	009681-2-12		P-28	Screw	2	154149-0-01	
P-11	Presser Bar Clamp S	1	156038-0-01		P-29	Presser Cam	1	155743-0-01	
P-12	Presser Bar Bushing	1	145472-0-01		P-30-1	Needle Bar Clamp	1		P-30 Needle Bar Clamp With Screw 183151-0-01
P-13	Presser Foot (A)	1	152283-1-01		P-30-2	Screw 4.37	1	009681-2-12	
P-14	Screw 3.57 x 8	1	001670-8-14		P-31	Finger Guard	1		
P-15	Roller Stud	1	155051-0-01		P-32	Washer 3	1		
P-16	Roller	1	155052-0-01		P-33	Bolt 3 x 8	1		
P-17	Stop Ring E5	1	048050-3-42						
P-18	Washer 4	2	025040-1-32						

Q. Table Unite

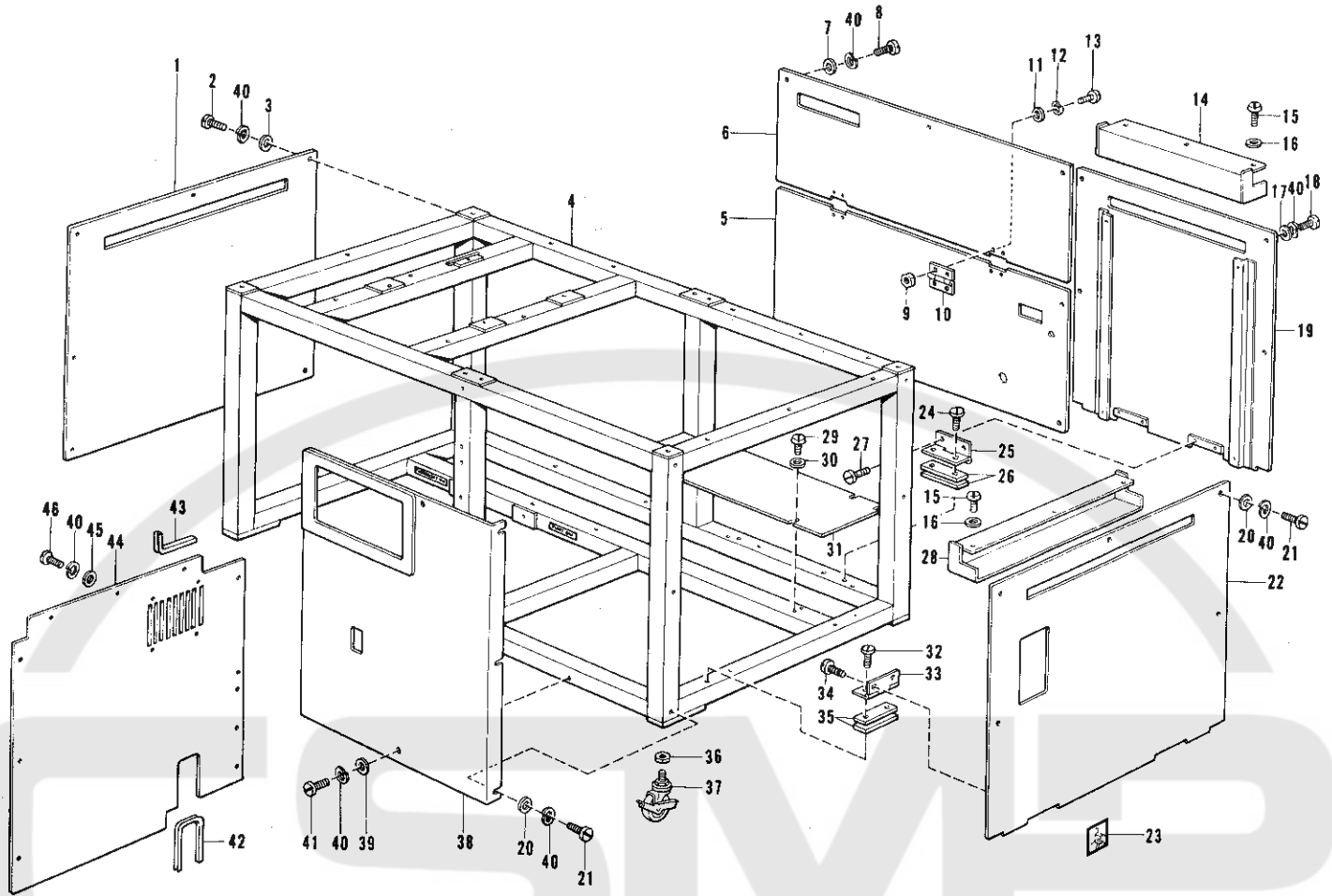

Ref. No.	Name of Parts	Q'ty	Parts No.	Assembly No.	Ref. No.	Name of Parts	Q'ty	Parts No.	Assembly No.
Q- 1	Side Cover L	1	155649-0-01		Q-24	Screw 4 x 14	4	007401-4-13	
Q- 2	Screw 4 x 8	8	007400-8-13		Q-25	Hinge	2	152575-0-00	
Q- 3	Washer 4	8	025040-2-33		Q-26	Hinge Supporter	4	155641-0-01	
Q- 4	Stand	1	155636-0-01		Q-27	Screw 4 x 5	4	007400-5-13	
Q- 5	Rear Cover LD	1	155651-0-01		Q-28	Grip Cover (R)	1	155647-0-01	
Q- 6	Rear Cover LU	1	155652-0-01		Q-29	Screw 4 x 8	4	007400-8-13	
Q- 7	Washer 4	8	025040-2-33		Q-30	Washer 4	4	025040-2-33	
Q- 8	Screw 4 x 8	8	007400-8-13		Q-31	Blind Plate	1	155705-0-01	
Q- 9	Nut 3	8	021300-1-03		Q-32	Screw 4 x 14	4	007401-4-13	
Q-10	Hook Cover Hinge	2	152423-0-00		Q-33	Hinge	2	152575-0-00	
Q-11	Washer 3	8	025030-2-33		Q-34	Screw 4 x 5	4	007400-5-13	
Q-12	Washer 2-3	8	028030-2-43		Q-35	Hinge Supporter	4	155641-0-01	
Q-13	Screw 3 x 8	8	007300-8-03		Q-36	Nut 16	4	021160-3-03	
Q-14	Grip Cover (B)	1	155648-0-01		Q-37	Caster	4	152393-0-00	
Q-15	Screw 4 x 8	6	007400-8-13		Q-38	Front Cover	1	155638-0-01	
Q-16	Washer 4	6	025040-2-33		Q-39	Washer 4	2	025040-2-33	
Q-17	Washer 4	5	025040-2-33		Q-40	Washer 2-4	35	028040-2-43	
Q-18	Screw 4 x 8	5	007400-8-13		Q-41	Screw 4-8	2	007400-8-13	
Q-19	Rear Cover R Assembly	1	155645-0-01		Q-42	Bushing	1	157005-1-02	
Q-20	Washer 4	6	025040-2-33		Q-43	Bushing	1	157005-1-03	
Q-21	Screw 4 x 8	6	007400-8-13		Q-44	Inside Cover	1	155650-0-01	
Q-22	Side Cover R Assembly	1	155639-0-01		Q-45	Washer 4	6	025040-2-33	
Q-23	Connector Seal	1	157212-0-01		Q-46	Screw 4 x 8	6	007400-8-13	

R. Power Supply Equipment Mechanism (1)

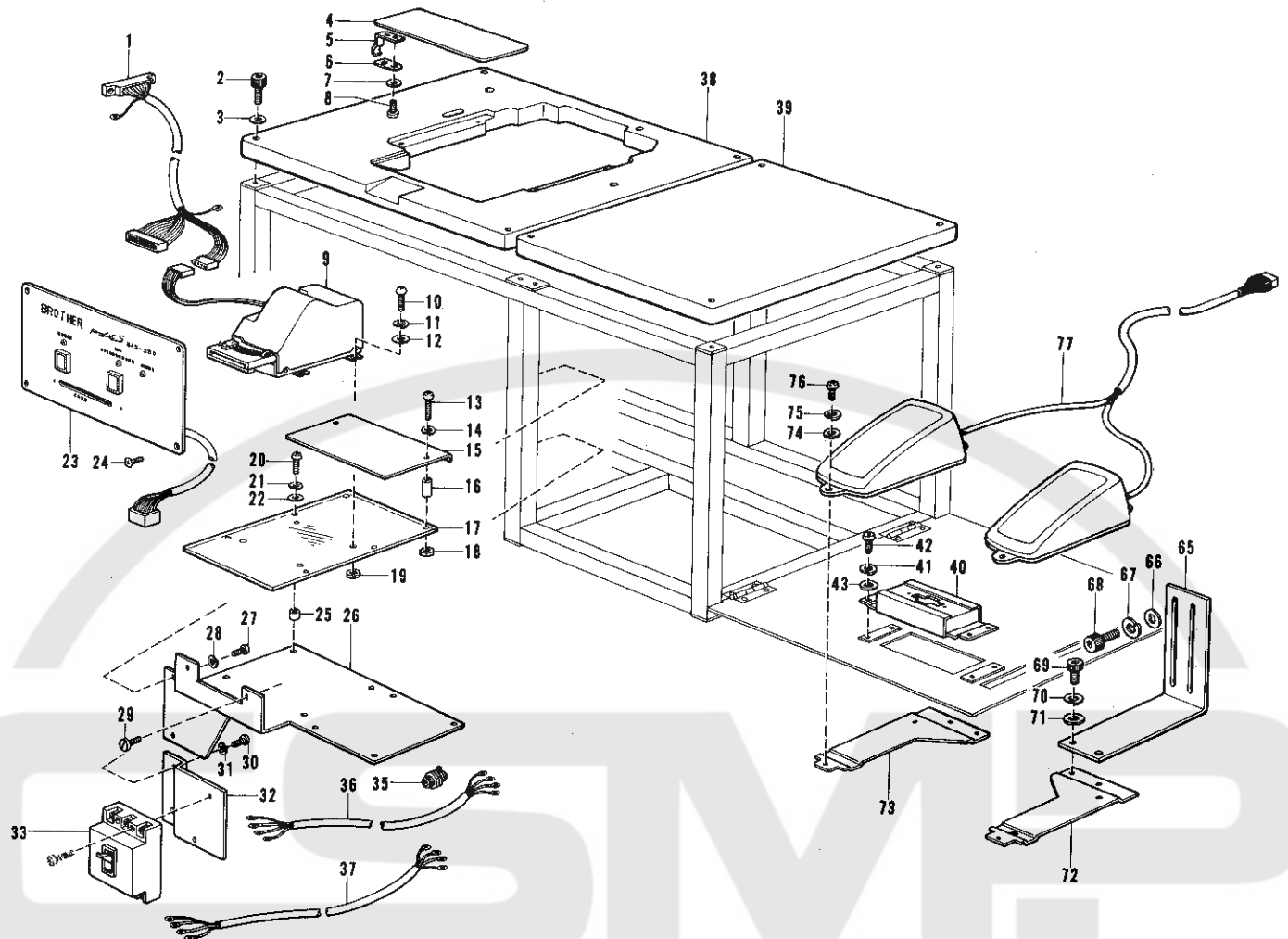

Ref. No.	Name of Parts	Q'ty	Parts No.	Assembly No.	Ref. No.	Name of Parts	Q'ty	Parts No.	Assembly No.
R-1	Reader Harness Assembly	1	152446-0-01		R-29	Screw 3 x 6	2	007300-6-12	
R-2	Bolt 4 x 50	8	018505-0-22		R-30	Screw 4 x 10	2	007401-0-12	
R-3	Washer 5	8	025050-1-32		R-31	Washer 2-4	2	028040-2-42	
R-4	Oil Pan Cover	1	155654-0-01		R-32	Switch Setting Plate (B)	1	152662-0-01	
R-5	Spring Plate L	4	155655-0-01		R-33	Fuse Breaker (B)	1	152661-0-00	
R-6	Belt Cover Stopper	4	152986-0-01		R-35	Bushing	1	152510-0-00	
R-7	Washer 3	8	025030-2-32		R-36	Cable Assembly (C)	1	155759-0-00	
R-8	Screw 3 x 6	8	007300-6-12		R-37	Cable Assembly (A)	1	154135-0-01	
R-9	Card Reader	1	152500-0-00		R-38	Table SL	1	155693-0-01	
R-10	Screw 4 x 10	4	002401-0-03		R-39	Table SR	1	155658-0-01	
R-11	Washer 2-4	4	028040-2-43		R-40	Connector Setting Plate	1	152416-0-01	
R-12	Washer 4	4	025040-2-33		R-41	Screw 4 x 6	4	007400-6-13	
R-13	Screw 3 x 30	2	002303-0-06		R-42	Washer 2-4	4	028040-2-43	
R-14	Washer 2-3	2	028030-2-43		R-43	Washer 4	4	025040-2-33	
R-15	Card Reader Rear Cover	1	154033-0-00		R-65	Foot Switch Supporter	2	155667-0-01	
R-16	Spacer	2	154034-0-00		R-66	Washer 5	2	025050-0-32	
R-17	Card Reader Setting Plate	1	154097-0-00		R-67	Washer 2-5	2	028050-2-42	
R-18	Nut 3	2	021300-1-03		R-68	Bolt M5 x 12	2	018501-2-22	
R-19	Nut 4	4	021400-1-03		R-69	Bolt 4 x 8	4	018400-8-22	
R-20	Screw 3 x 20	4	007302-0-13		R-70	Washer 2-4	4	028040-2-42	
R-21	Washer 3	4	025030-2-33		R-71	Washer 4	4	025040-2-32	
R-22	Washer 2-3	4	028030-2-43		R-72	Foot Switch Setting Plate (R)	1	155668-0-01	
R-23	Switch Board S Assembly (B)	1	155730-0-00		R-73	Foot Switch Setting Plate (L)	1	155669-0-01	
R-24	Screw 4 x 7	3	004400-7-02		R-74	Washer 4	4	025040-2-33	
R-25	Spacer A	4	152544-0-00		R-75	Washer 2-4	4	028040-2-43	
R-26	Card Reader Base	1	155637-0-01		R-76	Screw 4 x 10	4	002401-0-03	
R-27	Screw 4 x 10	2	002401-0-03		R-77	Foot Switch S Assembly	1	155835-0-01	
R-28	Washer 2-4	2	028040-2-43						

R. Power Supply Equipment Mechanism (2)

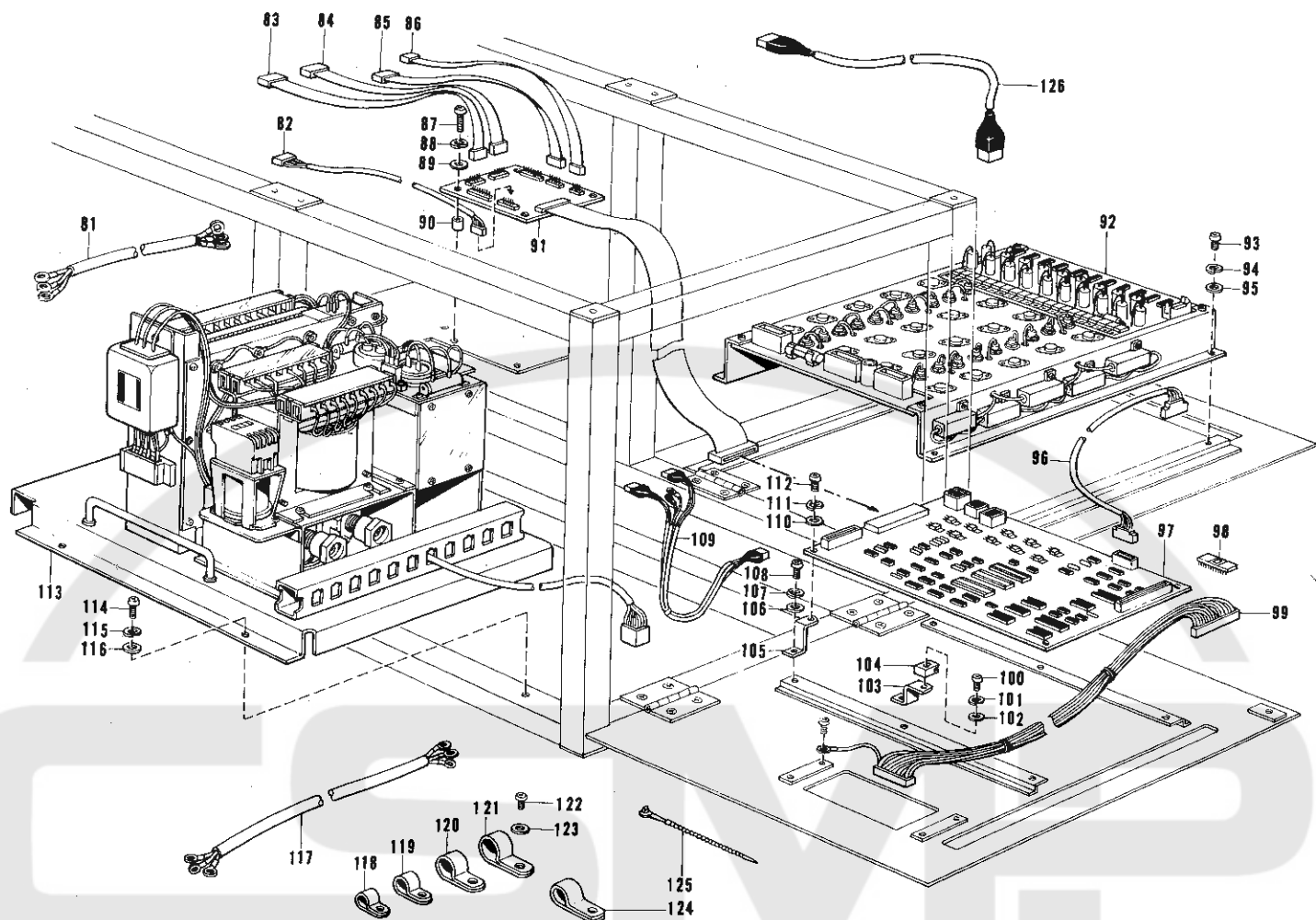

Ref. No.	Name of Parts	Q'ty	Parts No.	Assembly No.	Ref. No.	Name of Parts	Q'ty	Parts No.	Assembly No.
R- 81	Relay Harness B Assembly	1	155758-0-00		R-105	Circuit Board Supporter 3	4	155792-0-01	
R- 82	Synchronizer Switch Y Harness	1	155763-0-00		R-106	Washer 4	6	025040-2-33	
R- 83	Micro Switch Y Harness	1	155765-0-00		R-107	Washer 2-4	6	028040-2-43	
R- 84	Micro Switch X Harness	1	155764-0-00		R-108	Screw 4 x 10	6	002401-0-03	
R- 85	Presser Switch Harness	1	155762-0-00		R-109	Solenoid Harness Assembly	1	155751-0-00	
R- 86	Synchronizer Harness	1	155761-0-00		R-110	Washer 3	4	025030-2-33	
R- 87	Screw 4 x 25	4	002402-5-12		R-111	Washer 2-3	4	028030-2-43	
R- 88	Washer 2-4	4	028040-2-42		R-112	Screw 3 x 12	4	002301-2-03	
R- 89	Washer 4	4	025040-2-32						
R- 90	Spacer A	4	152544-0-00		R-113	Power Supply Equipment Assembly (B)	1	155816-0-00	
R- 91	Extension Board	1	155744-0-00		R-114	Screw 4 x 10	4	002401-0-03	
R- 92	PMD P.C Board Assembly	1	152461-0-01		R-115	Washer 2-4	4	028040-2-43	
R- 93	Screw 4 x 10	4	002401-0-03		R-116	Washer 4	4	025040-2-33	
R- 94	Washer 2-4	4	028040-2-43		R-117	Reader Harness A Assembly	1	155757-0-00	
R- 95	Washer 4	4	025040-2-33		R-118	Cord Holder #6	9	525664-0-00	
R- 96	Clock Harness S Assembly	1	155750-0-00		R-119	Cord Holder #9	3	525907-0-00	
R- 97	Printed Circuit Board	1	155766-0-00		R-120	Cord Holder #12	5	554482-0-00	
R- 98	PROM S Assembly	1	155789-0-00		R-121	Cord Holder #14	12	552908-0-00	
R- 99	Programmer Harness S Assembly (A)	1	155826-0-00		R-122	Screw 4 x 10	34	002401-0-03	
R-100	Screw 3 x 16	2	002301-6-05		R-123	Washer 4	34	025040-2-33	
R-101	Washer 2-3	2	028030-2-43		R-124	Cord Holder	5	149547-0-01	
R-102	Washer 3	2	025030-2-33		R-125	Bead Band	5	340400-0-01	
R-103	Circuit Board Supporter 4	2	155793-0-01		R-126	Air Valve Harness Assembly	1	155794-0-01	
R-104	Fixing Plate	2	152454-1-00						

T. Actuator Mechanism

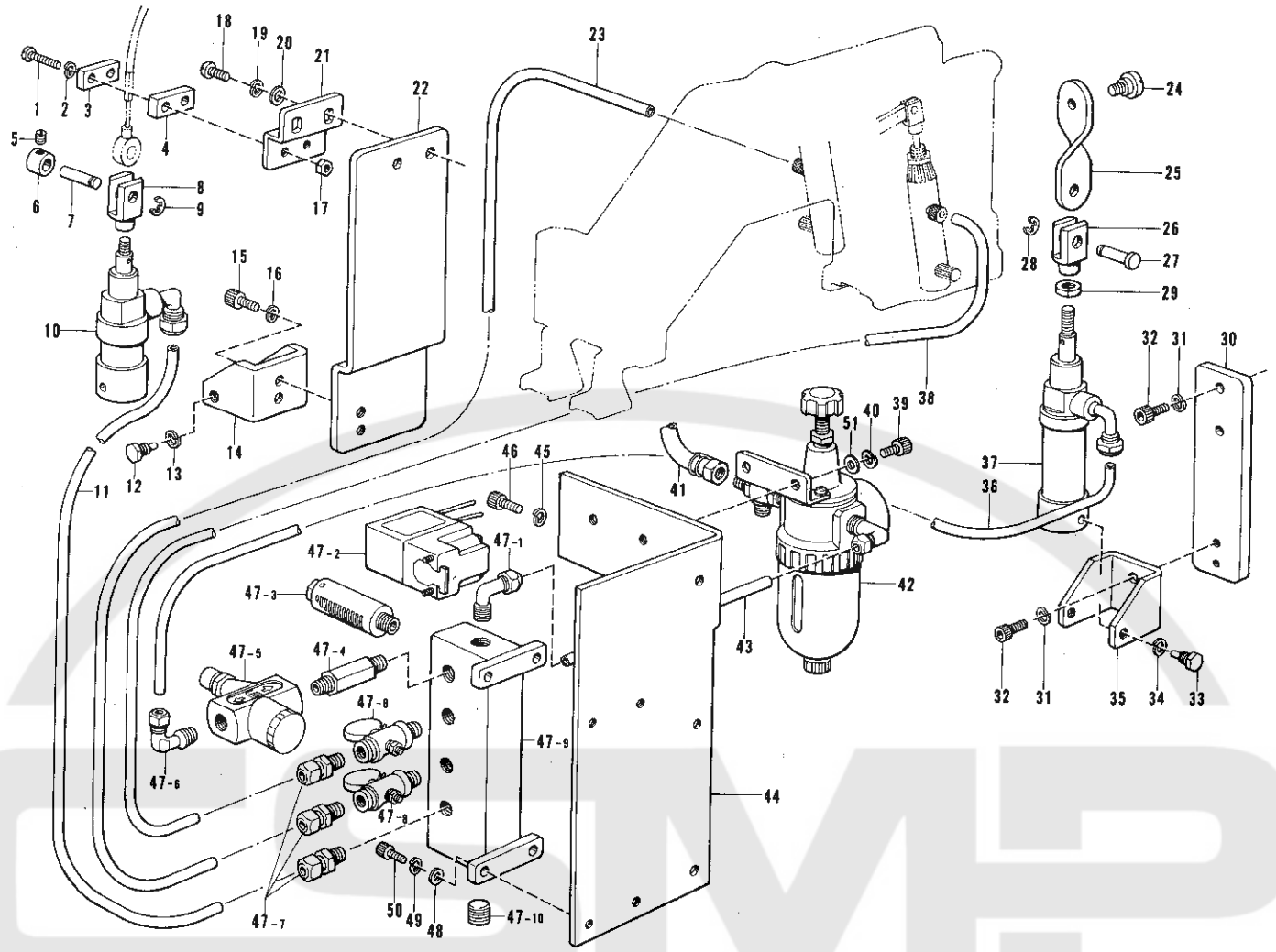

Ref. No.	Name of Parts	Q'ty	Parts No.	Assembly No.	Ref. No.	Name of Parts	Q'ty	Parts No.	Assembly No.
T-1	Screw 4 x 25	2	007402-5-12		T-31	Washer 2-6	2	028060-2-42	
T-2	Washer 2-4	2	028040-2-42		T-32	Bolt M5 x 12	4	018501-2-22	
T-3	Wire Holder Upper (B)	1	152381-1-01		T-33	Screw	2	140620-0-01	
T-4	Wire Holder Lower (D)	1	155071-0-01		T-34	Washer 2-6	2	028060-2-42	
T-5	Screw 4.37	1	151601-0-02		T-35	Cylinder Bracket	1	151735-0-01	
T-6	Collar	1	120068-0-01		T-36	Air Tube	1	156026-0-04	
T-7	Pin	1	156048-0-01		T-37	Cylinder Assembly	1	155624-0-00	
T-8	Piston Rod Joint	1	140627-0-01		T-38	Air Tube	1	156026-0-03	
T-9	Stop Ring E4	1	048040-3-42		T-39	Bolt 6 x 12	2	018061-2-22	
T-10	Presser Cylinder Assembly	1	156043-0-00		T-40	Washer 2-6	2	028060-2-42	
T-11	Air Tube	1	156026-0-01		T-41	Clip	1	149796-0-01	
T-12	Screw	2	140620-0-01		T-42	Air Unit Assembly	1	156025-0-01	
T-13	Washer 2-6	2	028060-2-42		T-43	Air Tube	1	156027-0-00	
T-14	Cylinder Bracket	1	151735-0-01		T-44	Air Unit Supporter	1	155643-0-01	
T-15	Bolt M5 x 12	2	018501-2-22		T-45	Washer 2-4	3	028040-2-42	
T-16	Washer 2-5	2	028050-2-42		T-46	Bolt 4 x 8	3	018400-8-22	
T-17	Nut 4	2	021400-1-03		T-47-1	1/4" Elbow	1	149510-0-00	
T-18	Screw 4 x 10	2	007401-0-12		T-47-2	Solenoid Valve	4		
T-19	Washer 2-4	2	028040-2-43		T-47-3	Silencer	4	140682-0-01	
T-20	Washer 4	2	025040-2-33		T-47-4	Speed Control Connector	1	142037-0-00	T-47 Solenoid Valve Assembly 156023-0-01
T-21	Wire Holder Plate	1	156045-0-01		T-47-5	Speed Controller	1	142038-0-01	
T-22	Presser Cylinder Plate	1	156044-0-01		T-47-6	1/8" Elbow	1	149503-0-01	
T-23	Air Tube	1	156026-0-02		T-47-7	1/8" Connector	3	149435-0-00	
T-24	Screw 5.95	1	155629-0-01		T-47-8	Speed Controller	2	149438-0-00	
T-25	Connecting Plate	1	155628-0-01		T-47-9	Solenoid Base	1		
T-26	Piston Rod Joint	1	149411-0-01		T-47-10	Cap	1	140542-0-01	
T-27	Pin	1	146153-0-01		T-48	Washer 4	4	025040-2-32	
T-28	Stop Ring E4	1	048040-3-42		T-49	Washer 2-4	4	028040-2-42	
T-29	Nut 6	1	021060-3-06		T-50	Bolt 4 x 10	4	018401-0-22	
T-30	Cylinder Plate	1	155623-0-01		T-51	Washer 6	2	025060-0-32	

Z. Accessories (1)

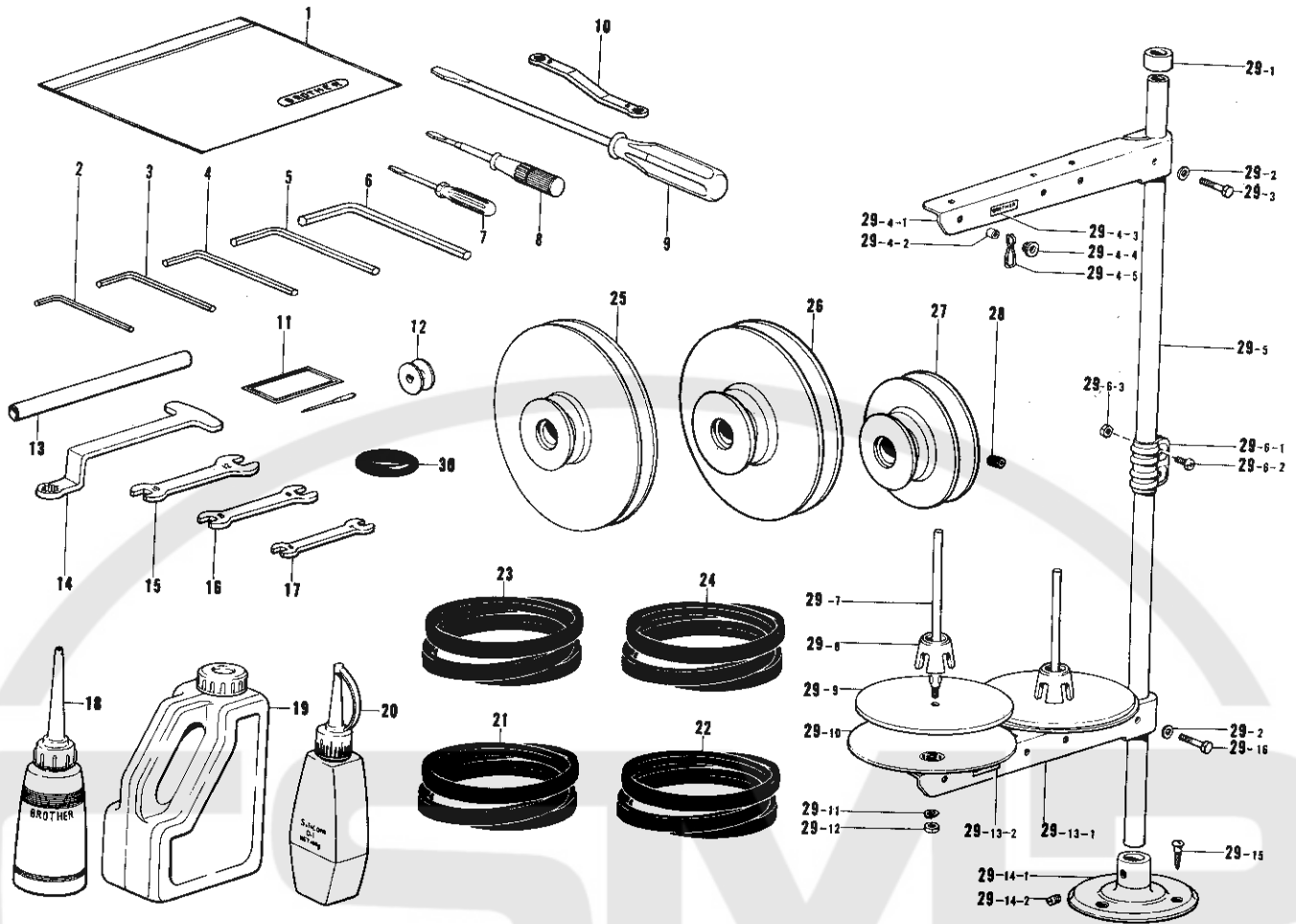

Ref. No.	Name of Parts	Q'ty	Parts No.	Assembly No.	Ref. No.	Name of Parts	Q'ty	Parts No.	Assembly No.
Z- 1	Vinyl Bag		122991-0-01		Z-29- 1	Cap			
Z- 2	Allen Wrench 2		142002-0-01		Z-29- 2	Washer 5		025050-2-33	
Z- 3	Spanner 3		142721-0-01		Z-29- 3	Bolt 5 x 28		017502-8-03	
Z- 4	Wrench 4		118064-0-01		Z-29- 4-1	Spool Holder 2			Z-29-4 Thread Hanger Assembly 150192-0-01
Z- 5	Spanner 5		147487-0-01		Z-29- 4-2	Thread Bushing		142990-0-01	
Z- 6	Allen Wrench		115157-0-01		Z-29- 4-3	Name Plate			
Z- 7	Screw Driver 1.9 x 52		142443-0-01		Z-29- 4-4	Thread Hanger			
Z- 8	Screw Driver 3.4 x 70		118837-0-01		Z-29- 4-5	Thread Guide Spring		150184-0-01	
Z- 9	Screw Driver 5.5 x 190		101572-1-01		Z-29- 5	Pipe		150172-0-01	
Z-10	Wrench 8 x 9		105343-0-01		Z-29- 6-1	Joint		150173-0-01	Z-29-6 Joint for Cotton Stand 150106-0-01
Z-11	Needle Assembly				Z-29- 6-2	Screw 5 x 14		150202-0-01	
Z-12	Bobbin				Z-29- 6-3	Nut 5		021500-1-03	
Z-13	Pipe		154760-0-01		Z-29- 7	Spool Shaft (B)		150179-0-01	
Z-14	Wrench 10		152765-0-01		Z-29- 8	Spool Cushion		126863-0-00	Z-29 Cotton Stand Base Assembly 150150-0-01
Z-15	Spanner 10 x 12		107780-0-01		Z-29- 9	Spool Mat		150182-0-00	
Z-16	Spanner 8 x 9		100887-0-01		Z-29-10	Spool Stand Base		150180-0-00	
Z-17	Spanner 6 x 7		107779-0-01		Z-29-11	Washer 2-5		028050-2-43	
Z-18	Oiler		114483-0-01		Z-29-12	Nut 5		021500-1-03	
Z-19	Oil Tank		154702-0-01		Z-29-13-1	Spool Holder 2			Z-29-13 Spool Holder Assembly 150177-0-01
Z-20	Silicon Oil		156334-0-02		Z-29-13-2	Name Plate			
Z-21	V Belt (for Low Speed)		082104-8-90		Z-29-14-1	Cotton Stand Base		150189-0-01	Z-29-14 Cotton Stand Base Assembly 150139-0-01
Z-22	V Belt (for 1000 rpm)				Z-29-14-2	Screw 6 x 7		150181-1-01	
Z-23	V Belt 49" (for 1500 rpm)				Z-29-15	Screw 4.5 x 22		031452-2-03	
Z-24	V Belt 51" (for 1800 rpm)				Z-29-16	Bolt 5 x 28		017502-8-03	
Z-25	Motor Pulley (for 1800 rpm)				Z-30	Rubber Ring		120448-0-01	
Z-26	Motor Pulley (for 1500 rpm)								
Z-27	Motor Pulley (for 1000 rpm)								
Z-28	Screw 5.95 x 6		014760-6-22						

*The details of included accessories are subject to change.

*Änderungen in der Aufstellung der mitgelieferten Zubehöre sind vorbehalten.

*Les détails des accessoires inclus sont sujets à des changements.

*Los detalles de los accesorios incluidos pueden variar.

Z. Accessories (2)

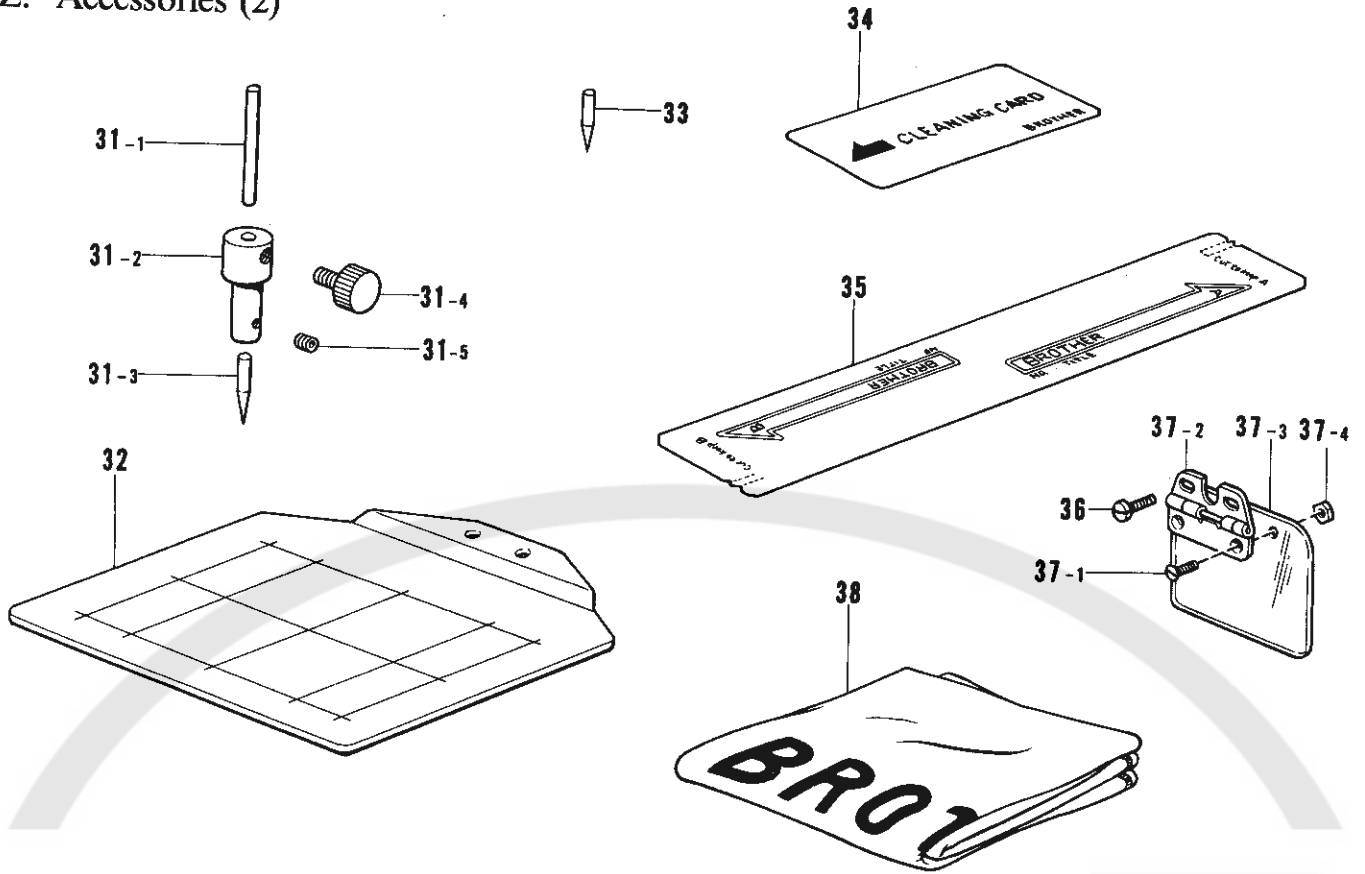

Ref. No.	Name of Parts	Q'ty	Parts No.	Assembly No.	Ref. No.	Name of Parts	Q'ty	Parts No.	Assembly No.
Z-31-1	Program Needle Guide		155672-0-00	Z-31 Program Needle Assembly 155670-0-01	Z-35	Memory Card		152599-0-00	
Z-31-2	Program Needle Holder		155671-0-01		Z-36	Screw 3.57 x 5		009670-5-12	
Z-31-3	Program Needle		155674-0-01		Z-37-1	Screw 3.57		102538-0-07	Z-37 Eye Guard Assembly 153100-0-00
Z-31-4	Screw		155673-0-01		Z-37-2	Eye Guard Hinge Assembly		153102-0-01	
Z-31-5	Screw 3		014300-4-22		Z-37-3	Eye Guard		153098-0-00	
Z-32	Program Standard Plate		155706-0-01	Z-37-4	Nut 3.57		106129-0-01		
Z-33	Program Needle		155674-0-01	Z-38	Head Cover		144226-0-01		
Z-34	Cleaning Card		152598-0-00						

a. Programmer Device

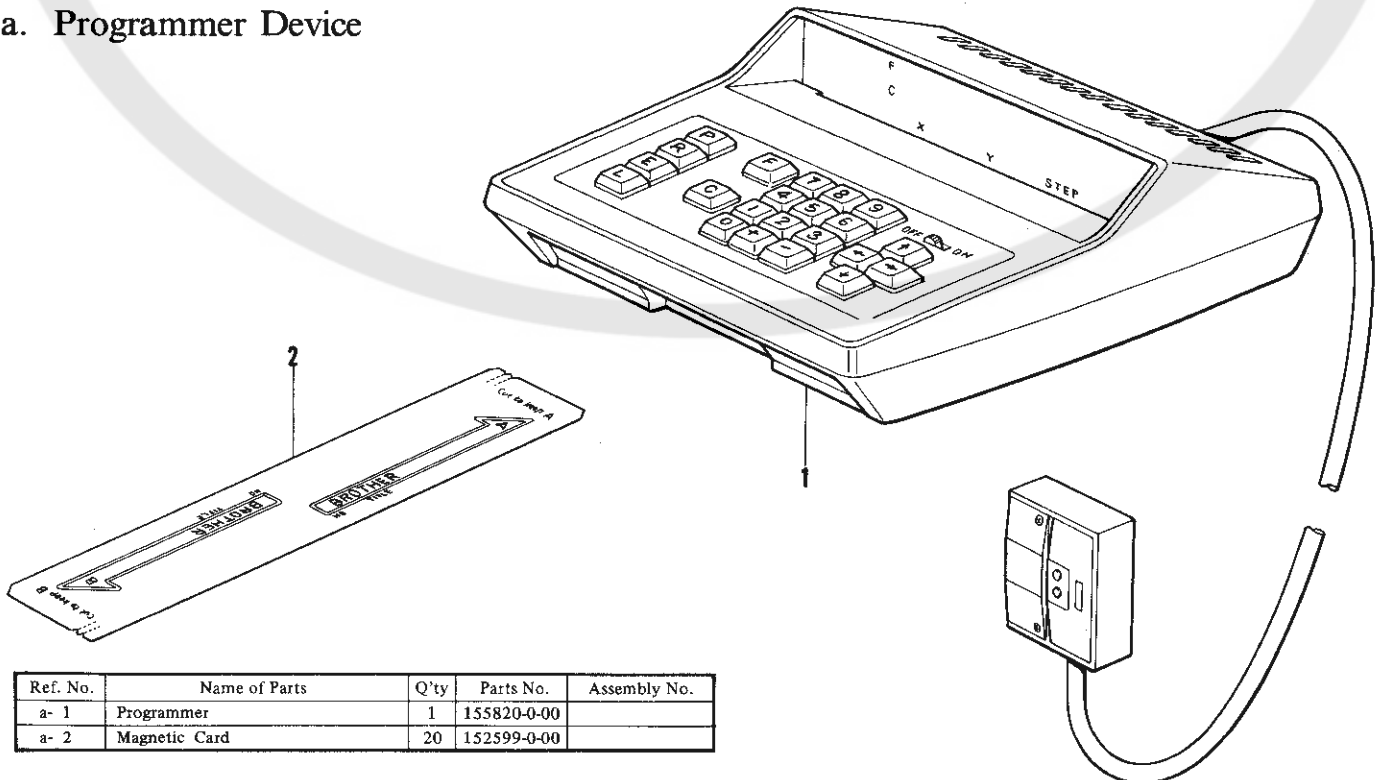





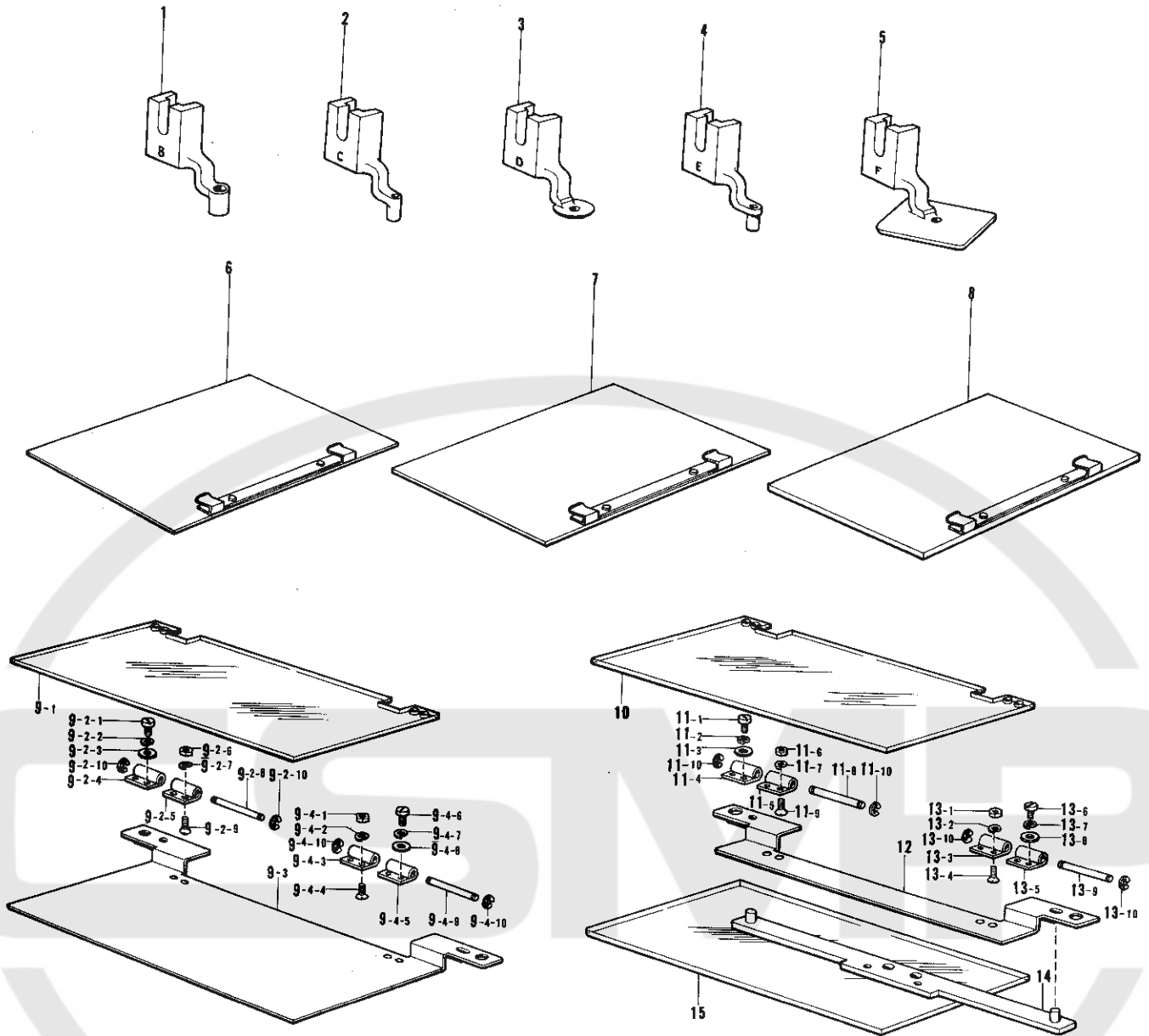

Ref. No.	Name of Parts	Q'ty	Parts No.	Assembly No.
a- 1	Programmer	1	155820-0-00	
a- 2	Magnetic Card	20	152599-0-00	







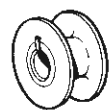

b. Optional Parts



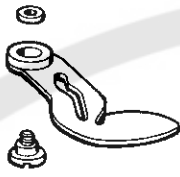

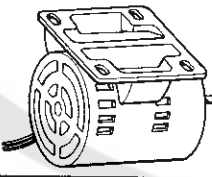

Ref. No.	Name of Parts	Q'ty	Parts No.	Assembly No.	Ref. No.	Name of Parts	Q'ty	Parts No.	Assembly No.
b-9-1	Cossette Plate U-A	1	157717-0-00	b-9-2 Hinge Assembly (L) 152633-0-01	b-10	Cassette Plate (A)	1	157718-0-01	b-11 Hinge Assembly (L) 152633-0-01
b-9-2- 1	Screw 3 x 5	2	001300-5-03		b-11- 1	Screw 3 x 5	2	001300-5-03	
b-9-2- 2	Washer 2-3	2	028030-2-43		b-11- 2	Washer 2-3	2	028030-2-43	
b-9-2- 3	Washer	2	025030-1-33		b-11- 3	Washer	2	025030-1-33	
b-9-2- 4	Hinge (A)	1	152627-0-01		b-11- 4	Hinge (A)	1	152627-0-01	
b-9-2- 5	Hinge (B)	1	152628-0-01		b-11- 5	Hinge (B)	1	152628-0-01	
b-9-2- 6	Nut	2	021300-1-03		b-11- 6	Nut	2	021300-1-03	
b-9-2- 7	Washer 2-3	2	028030-2-43		b-11- 7	Washer 2-3	2	028030-2-43	
b-9-2- 8	Hinge Shaft	1	152629-0-01		b-11- 8	Hinge Shaft	1	152629-0-01	
b-9-2- 9	Screw 3 x 6	2	003300-6-04		b-11- 9	Screw 3 x 6	2	003300-6-04	
b-9-2-10	Stop Ring E2	2	048020-3-42	b-11-10	Stop Ring E2	2	048020-3-42		
b-9-3	Cassette Plate D-A	1	157714-0-01	b-9-4 Cassette Presser Assembly 157713-0-01	b-12	Cassette Plate D-B	1	157715-0-01	b-13 Hinge Assembly (R) 152632-0-01
b-9-4- 1	Nut	2	021300-1-03		b-13- 1	Nut	2	021300-1-03	
b-9-4- 2	Washer 2-3	2	028030-2-43		b-13- 2	Washer	2	028030-2-43	
b-9-4- 3	Hinge (B)	1	152628-0-01		b-13- 3	Hinge (B)	1	152628-0-01	
b-9-4- 4	Screw 3 x 6	2	003300-6-04		b-13- 4	Screw 3 x 6	2	003300-6-04	
b-9-4- 5	Hinge (A)	1	152627-0-01		b-13- 5	Hinge (A)	1	152627-0-01	
b-9-4- 6	Screw 3 x 5	2	001300-5-03		b-13- 6	Screw 3 x 5	2	001300-5-03	
b-9-4- 7	Washer 2-3	2	028030-2-43		b-13- 7	Washer 2-3	2	028030-2-43	
b-9-4- 8	Washer	2	025030-1-33		b-13- 8	Washer	2	005030-1-33	
b-9-4- 9	Hinge Shaft	1	152629-0-01		b-13- 9	Hinge Shaft	1	152629-0-01	
b-9-4-10	Stop Ring E2	2	048020-3-42	b-13-10	Stop Ring E2	2	048020-3-42		
				b-9-4 Hinge Assembly (R) 152632-0-01	b-14	Cassette Holder Plate	1	157716-0-01	
					b-15	Cassette Plate (B)	1	157719-0-01	

DIFFERENT PARTS LIST

Ref. No.	Name of Parts	Parts No.	
B- 1		Needle DB x 1 #9	100265-0-29
		Needle DB x 1 #11	100265-0-31
		Needle DB x 1 #23	100265-0-43
		Needle DB x 1 #25	100265-0-45
		Needle DP x 5 #9	107415-0-09
		Needle DP x 5 #11	107415-0-11
		Needle DP x 5 #14	107415-0-14
		Needle DP x 5 #16	107415-0-16
		Needle DP x 5 #18	107415-0-18
		Needle DP x 5 #19	107415-0-19
		Needle DP x 5 #21	107415-0-21
		Needle DP x 5 KN #10	154763-0-10
		Needle DP x 17 #14	145646-0-14
		Needle DP x 17 #16	145646-0-16
		Needle DP x 17 #18	145646-0-18
		Needle DP x 17 #19	145646-0-19
		Needle DP x 17 #21	145646-0-21
Needle PF x 34 R #8	148436-0-08		
B- 2		Needle Bar Thread Guide A	152890-0-01
		Needle Bar Thread Guide B	154664-0-01
B- 6		Needle Bar A ($\phi 2.00$)	152233-0-01
		Needle Bar B ($\phi 1.62$)	152241-0-01
		Needle Bar C ($\phi 2.02$)	153346-0-01
B-64		Shuttle Hook A (for standard)	152685-0-01
		Shuttle Hook B (for thick materials)	152687-0-01
B-65		Shuttle Rece Ring A (for standard)	152682-0-01
		Shuttle Rece Ring B (for thick materials)	152686-0-01
B-66		Bobbin (for standard)	145265-0-01
		Bobbin B (for very thick materials)	154663-0-01
B-67		Bobbin Case Assembly A (for standard)	152688-1-01
		Bobbin Case Assembly B (for very thick materials)	152690-1-01

Ref. No.	Name of Parts		Parts No.
J-16		Needle Hole Plate A ($\phi 1.6$)	156149-0-01
		Needle Hole Plate B ($\phi 2.2$ groove)	156150-0-01
		Needle Hole Plate C ($\phi 2.2$ cross-shaped groove)	156151-0-01
		Needle Hole Plate D ($\phi 2.5$ cross-shaped groove)	156152-0-01
		Needle Hole Plate E ($\phi 2.6$)	156153-0-01
		Needle Hole Plate F ($\phi 2.2$)	156154-0-01
J-20		Movable Knife Assembly A	152901-0-01
		Movable Knife Assembly B	154176-0-01
J-21		Thread Retainer A	152906-1-01
		Thread Retainer B	154178-1-01
		Thread Retainer C	154531-1-01
J-69		Spring	155551-0-01
K-33		Thread Take-up Spring	145519-0-01
		Thread Take-up Spring B	144588-0-01
K-37		Tension Spring	104525-0-01
		Tension Spring	107606-0-01
L- 5		Three Phase Motor 200V	119971-0-01
		Three Phase Motor 220V	119721-0-02
		Three Phase Motor 380V	119721-0-03
		Three Phase Motor 400V	119721-0-04
P-31		Finger Guard	156042-0-01
P-32		Washer 3	025030-2-32
P-33		Bolt 3 x 8	018300-8-22
Z-11		Needle DB x 1 #9 Assembly	100265-4-29
		Needle DB x 1 #11 Assembly	100265-4-31
		Needle DB x 1 #23 Assembly	100265-4-43
		Needle DB x 1 #25 Assembly	100265-4-45
		Needle DP x 5 #9 Assembly	107415-4-09
		Needle DP x 5 #11 Assembly	107415-4-11
		Needle DP x 5 #14 Assembly	107415-4-14
		Needle DP x 5 #18 Assembly	107415-4-18

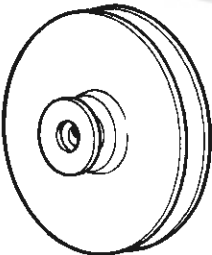
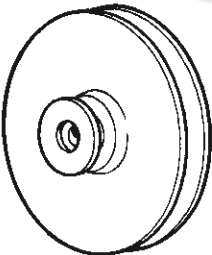
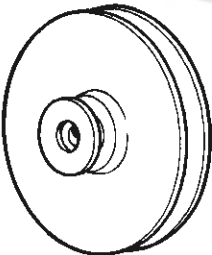
Ref. No.		Name of Parts	Parts No.
Z-11		Needle DP x 5 #19 Assembly	107415-4-19
		Needle DP x 5 #21 Assembly	107415-4-21
		Needle DP x 5 KN #10 Assembly	154763-4-10
		Needle DP x 17 #14 Assembly	145646-4-14
		Needle DP x 17 #16 Assembly	145646-4-16
		Needle DP x 17 #18 Assembly	145646-4-18
		Needle DP x 17 #19 Assembly	145646-4-19
		Needle DP x 17 #21 Assembly	145646-4-21
		Needle PF x 34 R #8 Assembly	148436-4-08
Z-12		Bobbin	145265-0-01
		Bobbin B	154663-0-01
Z-22		V Belt 49 1000/50	082104-9-90
		V Belt 48 1000/60	082104-8-90
Z-23		V Belt 50 1500/50	082105-0-90
		V Belt 49 1500/60	082104-9-90
Z-24		V Belt 51 1800/50	082105-1-90
		V Belt 50 1800/60	082105-0-90
Z-25		Motor Pulley 1800/50 (φ14)	153109-0-01
		Motor Pulley 1800/60 (φ14)	153108-0-01
		Motor Pulley B 1800/50 (φ15.88)	153803-0-01
		Motor Pulley B 1800/60 (φ15.88)	153802-0-01
Z-26		Motor Pulley 1500/50 (φ14)	153426-0-01
		Motor Pulley 1500/60 (φ14)	153425-0-01
		Motor Pulley 1500/50 (φ15.88)	153805-0-01
		Motor Pulley 1500/60 (φ15.88)	153804-0-01
Z-27		Motor Pulley 1000/50 (φ14)	154306-0-01
		Motor Pulley 1000/60 (φ14)	154305-0-01

INDEX

Parts No.	Ref. No.	Remark	Parts No.	Ref. No.	Remark	Parts No.	Ref. No.	Remark	Parts No.	Ref. No.	Remark
001300-5-03	b- 9- 2 1		009670-8-12	P-25		014760-6-22	J-61		025030-1-33	b- 9- 2- 3	
	b- 9- 4- 6		009671-0-12	J- 1			Z-28			b- 9- 4- 8	
	b-11- 1		009671-4-12	M-20- 6		014770-6-22	B-13			b-11- 3	
	b-13- 6		009680-6-12	A-41			B-14			b-13- 8	
001670-8-14	P-14			M- 2			B-48			P-32	
002021-4-05	F-69		009680-7-12	K-44-20			C- 2		025030-2-32	R- 7	
002301-2-03	R-112		009680-8-12	A-16			F-20		025030-2-33	Q-11	
002301-6-05	R-100			A-20			G-12			R-21	
002303-0-06	R-13			B- 7- 1			L-13			R-102	
002401-0-03	L-32			M-22		014821-0-22	G-43			R-110	
	N-11			P-20			D-15		025040-1-32	F-52	
	R-10		009681-0-12	F- 5		017062-5-03	L- 1			P-18	
	R-27			F- 7		017502-8-03	Z-29- 3		025040-2-32	E- 1- 9	
	R-76			K-42			Z-29-16			L-35	
	R-93			M-15		017680-5-12	E- 9			R-71	
	R-108		009681-2-12	P-10			E-12			R-89	
	R-114			P-30- 2		017711-4-12	D-37			T-48	
	R-122		009710-7-12	K- 1		017761-4-12	B-31		025040-2-33	L-33	
002402-5-12	R-87			N-21			E- 2			N-54	
003300-6-04	b- 9- 2- 9		009710-8-12	P-26		017762-2-02	D-49			Q- 3	
	b- 9- 4- 4		009711-0-12	F-76		018060-8-22	D- 5- 2			Q- 7	
	b-11- 9			N-51		018061-2-22	F-27			Q-16	
	b-13- 4		009711-2-12	N- 3			T-39			Q-17	
003400-8-04	F- 2			N- 5		018061-6-22	D-53			Q-20	
003781-8-14	F-18		009711-4-12	A- 2			G-31			Q-30	
004400-7-02	R-24			A-11		018062-0-22	G- 4			Q-39	
007300-6-12	R- 8		009761-4-12	A-10			G-40			Q-45	
	R-29			J-46		018063-0-22	F-24			R-12	
007300-8-03	Q-13			K-45			F-61			R-43	
007302-0-13	R-20		009781-4-12	B-10			G-16			R-74	
007400-5-13	Q-27		013710-5-12	P- 2			G-27			R-95	
	Q-34		013710-7-12	G-21		018081-2-22	F-30			R-106	
007400-6-13	R-41			G-23			F-37			R-116	
007400-8-12	L-36			H- 5			L-31			R-123	
007400-8-13	Q- 2		013719-4-12	L-24		018082-5-22	C-54			T-20	
	Q- 8		013760-6-12	H-24		018300-8-22	P-33		025040-3-32	N- 9	
	Q-15			K- 7		018400-8-22	R-69		025050-0-32	R-66	
	Q-18			L-26			S-36		025050-1-32	L-20	
	Q-21		013761-4-10	C-26			T-46			R- 3	
	Q-29			D-27		018401-0-22	T-50		025050-2-32	E- 1-36	
	Q-41		013761-4-12	B-12		018500-8-22	E- 1-28			F-78	
	Q-46			B-18			R-68			N- 2	
007401-0-12	R-30		014300-4-22	Z-31- 5			T-15			N- 7	
	T-18		014680-4-22	E- 1- 5			T-32			N-22	
007401-4-13	Q-24			J- 6		018501-4-22	B-62			N-50	
	Q-32		014680-6-22	B-36		018502-0-22	E- 1-35			Z-29- 2	
007402-5-12	T- 1			E- 1-18		018505-0-22	L-21		025060-0-32	T-51	
009660-3-12	B-54			H- 8			R- 2		025060-1-32	D-51	
009660-7-12	B-57			H-15		018681-0-22	J-36			J-47	
	C-19		014760-6-22	B-38		021020-1-03	F-84		025060-2-32	B-30	
009670-4-12	G-18			B-41		021060-1-02	L- 7			D-43	
	K- 8			B-44		021060-3-06	T-29			E- 3	
009670-5-12	C-60			B-51		021100-2-02	L- 9		025060-2-32	F-28	
	H- 2			C-51		021160-3-03	Q-36		025080-2-32	F-36	
	M- 8			D-12		021300-1-03	Q- 9			L-29	
	M-32			D-18- 2			R-18		025100-1-32	L-10	
	M-40			D-19			b- 9- 2- 6		025350-1-32	H- 3	
	M-45			E- 1-16			b- 9- 4- 1		025350-3-32	J- 2	
	Z-36			E- 5- 8			b-11- 6			M-20- 5	
009670-6-12	F-51			F-56		021400-1-03	R-19		025680-1-33	C-35- 6	
	F-66			F-75			T-17		025680-2-32	E-13	
	F-83			G- 9			Z-29- 6- 3		025770-2-32	A-32	
	K- 4			G-34		021500-1-02	E- 1-43			H-10	
	K-14			H-25			Z-29-12		025800-3-33	C-67	
	M-21			H-28			E- 1-22			L- 2	
	N-55			H-37		021670-1-02	M-20- 2		028020-2-43	F-68	
009670-7-12	K-44- 7			H-46		021670-2-02	C-35- 7			S-40	
	K-44-23			J-13		021680-2-02	C-68		028030-2-43	Q-12	
009670-8-12	A- 6			J-40		021800-1-03	F-67			R-14	
	M-20- 7			J-55		025020-2-35					

Parts No.	Ref. No.	Remark	Parts No.	Ref. No.	Remark	Parts No.	Ref. No.	Remark	Parts No.	Ref. No.	Remark	
028030-2-43	R-22		048040-3-42	T-28		102630-0-01	H-31		115493-0-02	A-45		
	R-101		048050-3-42	J-9		102716-0-04	K-44- 2		116629-0-01	H-14		
	R-111			J-35		102843-0-04	B-29		116920-0-01	B-24		
	b- 9- 2- 2			J-68		103950-0-02	K-30		117150-0-01	M- 9		
	b- 9- 2- 7			K-44-16		104450-0-01	A-33			M-39		
	b- 9- 4- 2			P-17			A-37		117363-0-01	C-40		
	b- 9- 4- 7			048060-3-42	E- 1-26		104525-0-01	K-37		117934-0-01	A- 1	
	b-11- 2				H-13		104567-0-01	K-40		117936-0-01	A- 5	
	b-11- 7				H-20			M- 3		118064-0-01	Z- 4	
	b-13- 2				H-41			M-28		118719-0-01	A-29	
	b-13- 7			B-61		M-30			118837-0-01	Z- 8		
028040-2-42	C-59		048100-1-42	L-15		104689-0-01	B-35		119721-0-02	L- 5		
	R-31		048108-1-42	C-41			C-69		119721-0-03	L- 5		
	R-70		048110-1-42	C-27		105343-0-01	Z-10		119721-0-04	L- 5		
	R-88			D-33		106129-0-01	Z-37- 4		119971-0-01	L- 5		
	T- 2			H-49		106147-0-01	C-21		120068-0-01	T- 6		
	T-45			J-64		107030-0-01	G-39- 3		120448-0-01	K-44- 5		
	T-49		048120-1-42	J-52		107038-0-03	E- 1- 4			Z-30		
028040-2-43	Q-40		048150-1-42	B-23		107149-0-01	B-33		122991-0-01	Z- 1		
	R-11		048160-1-42	D-16		107153-0-02	H-21		126863-0-00	Z-29- 8		
	R-28		048170-1-42	D- 1			H-40		139096-0-01	E- 1- 6		
	R-42		048240-2-42	C- 9		107231-0-02	D-10		140208-0-01	H-18		
	R-75		048320-2-42	L-28- 3		107415-0-09	B- 1			J-39		
	R-94		048350-1-42	C- 6		107415-0-11	B- 1		140392-0-01	A- 4		
	R-107		048350-2-42	D- 7		107415-0-14	B- 1		140407-0-01	P- 8		
	R-115		048620-2-42	C- 5		107415-0-16	B- 1		140407-0-02	E- 1-29		
	T-19		071047-6-50	F-70		107415-0-18	B- 1		140423-0-00	M-14- 2		
	028050-2-42	C-39		071095-2-50	C-20		107415-0-19	B- 1			M-47	
		D-36		072600-3-60	D- 8		107415-0-21	B- 1		140542-0-01	T-47-10	
F- 8			072600-7-60	C- 7		107415-4-09	Z-11		140620-0-01	T-12		
F-39			072630-2-60	B-26		107415-4-11	Z-11			T-33		
F-77			081001-6-70	P- 3		107415-4-14	Z-11		140627-0-01	T- 8		
N- 6			081003-6-70	B-46		107415-4-16	Z-11		140682-0-01	T-47- 3		
R-67				B-49		107415-4-18	Z-11		140726-0-00	B-21		
T-16			081008-0-70	J-24		107415-4-19	Z-11		141207-0-01	P- 5		
028050-2-43		Z-29-11		081014-0-70	F-31		107415-4-21	Z-11		141208-0-01	P- 6	
		028060-2-42	D-52		081024-0-70	F-33		107606-0-01	K-37		141334-0-01	G-36
D-54			082104-8-90	Z-21		107744-0-01	C-35- 3			J-43		
L- 6				Z-22		107779-0-01	Z-17		141472-0-02	D-21		
T-13			082104-9-90	Z-22		107780-0-01	Z-15		141528-0-01	K-26		
T-31				Z-23		108520-0-01	A-27		141550-0-01	K-44-11		
T-34			082105-0-90	Z-23		109239-0-02	A-44		141583-0-01	H-43		
T-40				Z-24		110027-0-01	G-33		141692-0-01	M-20- 4		
028080-2-42	C-53		082105-1-90	Z-24		110168-0-01	E- 1-37		141786-0-01	B-34		
	L-30		100032-0-03	E-17		110251-0-01	C-23		141808-0-01	A-36		
028100-2-42	L-11			J-15			D-45	141816-0-01	G-11			
028680-2-42	P-19		100134-0-01	K-36			E- 1-21	141860-0-01	L-28- 5			
031452-2-03	Z-29-15		100136-0-01	K-24		110495-0-03	B-47	142002-0-01	Z- 2			
046301-6-20	B-42- 2			K-38		110505-0-01	D-32	142037-0-00	T-47- 4			
046302-0-20	G-32-01- 3			K-39		111140-0-01	J-31	142038-0-01	T-47- 5			
047202-5-42	F-59		100197-0-02	E- 1-27		111865-0-01	D-20	142211-0-01	B- 8			
047251-6-40	M-44		100250-0-01	B-17			D-30	142443-0-01	Z- 7			
047501-2-42	A-14		100253-0-01	B- 7- 5			H-50	142566-0-01	K-44-13			
048020-3-42	b- 9- 2-10		100265-0-29	B- 1			J-65	142628-0-01	C-28			
	b- 9- 4-10		100265-0-31	B- 1		112468-0-01	J-67		D-29			
	b-11-10		100265-0-43	B- 1		112751-0-03	K- 6		H-48			
	b-13-10		100265-0-45	B- 1		113006-0-01	M-42		J-63			
			100265-4-29	Z-11		113316-0-01	K- 5		142721-0-01	Z- 3		
048030-3-42	C-35- 1		100265-4-31	Z-11		113431-0-02	C-35- 2	142990-0-01	Z-29- 4- 2			
048040-3-42	H- 7		100265-4-43	Z-11			D-35	143591-0-01	E- 1-12			
	C- 1- 3		100265-4-45	Z-11		114294-0-01	K-32	144226-0-01	Z-38			
	C-30		100315-0-02	A-30		114483-0-01	Z-18	144458-0-01	B- 3			
	F-10		100360-0-03	J-16		114486-0-01	L-39	144588-0-01	K-33			
	G-32- 5		100398-0-01	K-34		114985-0-01	A-40	144694-0-01	M-12			
	G-41- 4		100402-0-04	K-31		115003-0-01	C- 1- 6	144712-0-02	B-32- 1			
	H-11		100716-0-04	K-44- 3		115012-0-02	C-55	145265-0-01	B-66			
	H-19		100887-0-01	Z-16		115018-0-01	C-66		Z-12			
	J- 8		101572-1-01	Z- 9		115077-0-03	K-27	145318-0-01	E-15			
	J-38		101706-0-01	B-15		115138-0-01	K-44-18	145446-0-01	K-18			
	J-51		102538-0-07	Z-37- 1		115157-0-01	Z- 6		K-35			
	T- 9											

Parts No.	Ref. No.	Remark	Parts No.	Ref. No.	Remark	Parts No.	Ref. No.	Remark	Parts No.	Ref. No.	Remark
145446-0-01	K-41		151601-0-02	T- 5		152241-0-01	B- 6		152707-0-01	G- 5	
145472-0-01	P-12		151604-0-02	A-24		152242-0-01	B-11		152708-0-00	G- 2	
145478-0-01	E- 1-30		151735-0-01	T-14		152243-0-01	B- 5		152709-0-00	G- 1	
145480-0-01	A-28			T-35		152244-0-00	B- 9		152710-0-01	G- 3	
145482-0-01	P- 1		151886-0-01	C-45		152245-0-01	B-39		152711-0-00	G-10	
145519-0-01	K-33		151887-0-01	C-42		152246-0-01	B-40		152712-0-01	G-29	
145646-0-14	B- 1		151888-1-01	C-52		152247-0-01	B-37		152713-0-01	G- 8	
145646-0-16	B- 1		151889-0-01	C-62		152250-0-01	B-43		152715-0-01	G-13	
145646-0-18	B- 1		151890-0-00	C-63		152283-1-01	P-13		152718-0-01	F-72	
145646-0-19	B- 1		151891-0-01	C-65		152381-1-01	T- 3			G- 7	
145646-0-21	B- 1		151892-0-01	C-64		152393-0-00	Q-37		152723-0-01	G-28	
145646-4-14	Z-11		151893-0-01	C-61		152416-0-01	R-40		152725-0-00	F-23	
145646-4-16	Z-11		151894-0-01	C-29		152423-0-00	Q-10			F-60	
145646-4-18	Z-11		151895-0-00	C-32		152446-0-01	R- 1			G-15	
145646-4-19	Z-11		151898-0-01	C-31		152454-1-00	R-104			G-26	
145646-4-21	Z-11		151899-0-01	C-33		152461-0-01	R-92		152728-0-01	G-47	
146080-0-00	P-23		151900-0-01	C-25		152500-0-00	R- 9		152729-0-01	G-14	
146103-0-01	F-13		151901-0-01	C-50		152510-0-00	R-35		152730-0-01	G-25	
146104-0-00	F-14		151902-0-01	C-24		152544-0-00	R-25		152731-0-01	G-20	
146141-0-01	H-35		151903-0-01	C-22			R-90		152732-0-01	G-22	
146153-0-01	T-27		151904-1-01	C-35		152575-0-00	Q-25		152733-0-01	G-17	
146375-0-00	M-11		151905-1-01	C-35- 5			Q-33		152734-0-01	G-30	
146741-0-00	L-12		151906-1-01	C-35- 4		152598-0-00	Z-34		152735-1-01	G-32	
147111-0-01	C- 3		151907-0-01	C-34		152599-0-00	a- 2		152739-0-01	G-32- 3	
147151-0-00	G- 6			G-37			Z-35		152744-0-01	H-30	
147487-0-01	Z- 5			J-58		152627-0-01	b- 9- 2- 4		152745-0-01	F-74	
147745-0-00	M-14- 4		151908-0-01	C-36			b- 9- 4- 5		152756-0-01	C-44	
	M-34		151910-0-01	C-38			b-11- 4		152765-0-01	Z-14	
148133-0-01	E- 5- 2		151912-0-01	D-26		152628-0-01	b-13- 5		152788-0-00	E- 1-34	
148436-0-08	B- 1		151913-0-01	D-40			b- 9- 2- 5		152794-0-01	H-33	
148436-0-08	Z-11		151914-0-01	D-39			b- 9- 4- 3		152798-0-01	H-29	
148735-0-01	M-24		151915-0-01	G-39			b-11- 5		152799-0-01	H-26	
	M-36		151919-0-01	D-31		152629-0-01	b-13- 3		152800-2-01	H-32	
	M-48		151920-0-01	D-34			b- 9- 2- 8		152801-0-01	H-23	
148921-0-00	M-31		151922-0-01	D-48			b- 9- 4- 9		152802-0-01	H-27	
149411-0-01	T-26		151924-0-01	D-46			b-11- 8		152803-0-01	H-22	
149435-0-00	T-47- 7		151925-0-01	D-28		152632-0-01	b-13- 9		152805-0-01	H-38	
149438-0-00	T-47- 8		151927-0-01	C-49			b- 9- 4		152806-0-01	H-39	
149503-0-01	T-47- 6		151928-0-01	D-11			b-13		152808-1-01	D-25	
149510-0-00	T-47- 1		151929-0-00	C-46		152633-0-01	b- 9- 2			H-42	
149547-0-00	N-53		151932-0-01	D- 9			b-11		152811-0-01	H-45	
149547-0-01	R-124		151933-0-01	D- 5- 1- 1		152636-0-01	b- 1		152815-0-01	H-16	
149796-0-01	T-41		151936-0-01	D- 3		152637-0-01	b- 2		152816-0-01	H-12	
150106-0-01	Z-29- 6		151937-0-01	D- 2		152661-0-00	R-33		152822-0-01	H- 9	
150139-0-01	Z-29-14		151938-0-01	D- 4		152662-0-01	R-32		152823-0-01	H- 6	
150150-0-01	Z-29		151939-0-01	G-41		152676-0-01	B-45		152827-0-01	H- 4	
150172-0-01	Z-29- 5		151940-0-01	D- 5- 3		152677-0-01	B-52		152828-0-01	H- 1	
150173-0-01	Z-29- 6- 1		151941-0-01	D- 5- 4		152678-0-01	B-50		152830-0-02	A- 9	
150177-0-01	Z-29-13		151944-0-01	D-18		152679-0-01	B-53		152833-0-01	A- 3- 2	
150179-0-01	Z-29- 7		151946-0-00	C-10		152680-0-01	B-55		152834-0-02	A-12	
150180-0-00	Z-29-10		151947-1-01	D-18- 3		152681-1-01	B-63		152835-0-02	A-31	
150181-1-01	Z-29-14- 2		151948-0-01	D-18- 4		152682-0-01	B-65		152836-0-02	A-38	
150182-0-00	Z-29- 9		151949-0-01	D-23		152683-0-01	B-60		152838-0-01	A-42	
150184-0-01	Z-29- 4- 5		151951-0-01	D-22		152684-0-01	B-59		152839-0-01	A-39	
150189-0-01	Z-29-14- 1		151952-0-01	D-14		152685-0-01	B-64		152841-0-02	A- 7	
150192-0-01	Z-29- 4		151953-0-01	D-17		152686-0-01	B-65		152842-0-02	A-43	
150202-0-01	Z-29- 6- 2		151954-0-01	D-13		152687-0-01	B-64		152846-0-02	A-17	
150553-0-01	D-44		151995-0-01	B-20		152688-1-01	B-67		152847-0-00	A-21	
	G-38		151997-0-00	B-25		152690-1-01	B-67		152848-0-01	A-18	
	J-59		151998-0-00	B-27		152693-0-01	C- 1- 5		152852-1-01	L-28	
150554-0-02	C-56		151999-0-01	B-28		152694-0-01	C- 1- 4		152858-0-01	L-23	
150555-0-01	D-25- 2		152000-0-01	B-19		152695-0-01	C- 4		152859-0-01	L-22	
	H-42- 2		152191-0-01	B-42		152698-0-01	C-13		152860-0-01	L-19	
	H-44		152231-0-00	B-16		152699-0-01	C- 8		152861-1-01	L-16	
150556-0-01	D-24		152232-0-01	B- 7		152700-0-00	C-12		152863-0-01	L- 3	
	D-38		152233-0-01	B- 6		152701-0-01	C-11		152864-0-00	L- 4	
151163-0-01	C-48		152236-0-01	B- 7- 3		152703-0-00	C-15		152865-0-01	L- 8	
	N-48		152237-0-01	B- 7- 7		152704-0-00	C-14		152866-0-01	L-27	
151601-0-01	K-44-14		152238-0-01	B- 7- 6		152705-0-01	C-17		152867-0-00	A-23	
151601-0-02	K-16		152239-0-01	B- 7- 2		152706-0-01	C-18		152868-0-00	A-22	

Parts No.	Ref. No.	Remark	Parts No.	Ref. No.	Remark	Parts No.	Ref. No.	Remark	Parts No.	Ref. No.	Remark
152869-0-01	K- 2		152963-0-01	M-26		153597-0-01	J-22		155592-0-01	N-52	
152870-0-01	K- 3		152964-0-01	M-29		153598-0-01	J-25		155595-0-01	F-17	
152872-0-01	K-29		152966-0-01	M-20- 1		153802-0-01	Z-25		155596-0-01	F-26	
152873-0-01	K-28		152967-0-01	M-20- 3		153803-0-01	Z-25		155597-0-01	F-22	
152874-0-01	H-17		152968-0-01	H-34		153804-0-01	Z-26		155598-0-01	F-16	
152875-0-01	K-17		152969-0-01	M-33		153805-0-01	Z-26		155599-0-01	F-25	
152876-0-01	K-15			M-46		153867-1-01	D- 6		155600-0-01	F-35	
152877-0-01	K-20		152971-0-01	M-51		153918-0-01	M-14- 6		155601-0-01	F-29	
152878-0-01	K-21		152972-0-01	M-49		153919-0-01	M-14- 3		155602-0-01	F-32	
152879-1-01	K-22		152973-0-01	M-41		153920-0-01	M-50		155603-0-01	F-21	
152880-0-01	K-23			M-52		153921-0-01	M-38		155605-0-01	F-58	
152881-0-01	K-11		152974-0-01	M-35		153922-0-01	M-25		155606-0-01	F-80	
152883-0-00	K-10		152976-0-01	C-58			M-27		155607-0-01	F- 1	
152884-0-01	K- 9		152977-0-01	C-57		153924-0-01	M-37		155608-0-01	F- 9	
152886-0-01	J- 5		152978-0-01	M-23		153925-0-01	B-22		155609-0-01	F- 6	
152887-0-01	J- 7		152980-0-01	M-19		153926-0-01	E- 6		155610-0-01	F- 4	
152888-0-01	K-25		152981-0-01	J-29		153927-0-01	M-18		155611-0-01	F- 3	
152889-0-01	K-13		152982-1-01	K-44		153944-0-01	E- 1-14		155612-0-01	F-11	
152890-0-01	B- 2		152983-0-01	K-44-17		153947-0-01	E- 1-19		155613-0-01	F-12	
152891-0-01	B- 4		152984-0-01	K-44- 6		153957-0-01	E- 1-23		155614-0-01	F-82	
152892-0-01	J-37		152986-0-01	A-19		153958-0-01	N-20		155615-0-01	F-79	
152893-1-01	J-33		152986-0-01	R- 6		153959-0-01	N-23		155617-0-01	F-65	
152896-0-01	J-34		152988-0-01	J-11		153962-0-01	E- 1-13		155618-0-01	F-53	
152897-1-01	J-19		152989-0-01	A-15		154033-0-00	R-15		155619-0-01	N- 8	
152901-0-01	J-20		152992-0-01	M-10		154034-0-00	R-16		155620-0-01	N-12	
152904-0-01	J-26		153040-0-01	B-32		154069-0-01	b- 3		155621-0-00	N- 1	
152905-0-01	J-32		153044-0-01	C- 1		154089-0-01	b- 4		155623-0-01	T-30	
152906-1-01	J-21		153049-0-01	K-12		154097-0-00	R-17		155624-0-00	T-37	
152912-0-01	J-54		153050-0-00	B-56		154115-0-01	P- 7		155628-0-01	T-25	
152913-0-01	G-41- 3		153058-0-01	C- 1- 2		154135-0-01	R-37		155629-0-01	T-24	
	J-49		153098-0-00	Z-37- 3		154149-0-01	P-28		155636-0-01	Q- 4	
152914-0-01	G-24		153100-0-00	Z-37		154155-1-01	D-41		155637-0-01	R-26	
	G-41- 2		153102-0-01	Z-37- 2		154176-0-01	J-20		155638-0-01	Q-38	
	J-50		153108-0-01	Z-25		154178-1-01	J-21		155639-0-01	Q-22	
152915-0-01	J-48		153109-0-01	Z-25		154183-0-01	H-36		155641-0-01	Q-26	
152916-0-01	J-41		153138-0-01	K-19		154305-0-01	Z-27			Q-35	
152917-0-01	J-53		153141-0-01	G-19		154306-0-01	Z-27		155643-0-01	T-44	
152919-0-01	J-42		153195-0-01	G-32- 4		154332-0-01	D-25- 3		155645-0-01	Q-19	
152920-0-01	J-57		153208-0-01	J-14			H-42- 1		155647-0-01	Q-28	
152921-0-01	J-56		153219-0-01	J-27		154333-0-01	D-25- 1		155648-0-01	Q-14	
152922-0-01	J-60		153220-0-01	J-30			H-42- 3		155649-0-01	Q- 1	
152923-0-01	J-66		153222-0-01	J-28		154528-0-01	K-44- 4		155650-0-01	Q-44	
152924-0-01	H-47		153269-0-01	E- 1-41		154531-1-01	J-21		155651-0-01	Q- 5	
152925-1-01	J- 4		153330-0-01	B- 7-04		154663-0-01	B-66		155652-0-01	Q- 6	
152926-0-01	J- 3		153332-0-01	G-32- 1			Z-12		155654-0-01	R- 4	
152929-0-01	J-12		153346-0-01	B- 6		154664-0-01	B- 2		155655-0-01	R- 5	
152933-0-01	K-44-10		153347-1-01	F-73		154702-0-01	Z-19		155658-0-01	R-39	
152934-0-01	K-44- 1		153364-0-02	E- 1-17		154760-0-01	Z-13		155667-0-01	R-65	
152935-0-01	K-44-21		153369-0-01	E- 1- 2		154763-0-10	B- 1		155668-0-01	R-72	
152936-0-01	K-44- 9		153370-0-01	E- 1- 3		154763-4-10	Z-11		155669-0-01	R-73	
152937-0-01	K-44- 8		153372-0-01	E- 1- 1		154785-0-00	A-13		155670-0-01	Z-31	
152938-0-01	K-44-19		153383-0-01	E- 8		154788-0-01	J-45		155671-0-01	Z-31- 2	
152939-0-01	K-44-12		153384-0-01	E- 7		154789-0-01	J-44		155672-0-00	Z-31- 1	
152940-0-01	K-44-22		153391-0-01	E- 4		155005-1-01	L-38		155673-0-01	Z-31- 4	
152941-0-01	K-44-15		153393-0-01	F-71		155051-0-01	P-15		155674-0-01	Z-33	
152945-0-01	K-43		153403-0-02	E- 1- 8		155052-0-01	P-16		155677-0-01	E- 1	
152948-0-01	M-13		153424-0-01	J-18		155071-0-01	T- 4		155678-0-01	E- 1-11	
	M-43		153425-0-01	Z-26		155337-0-01	G-32- 2		155679-0-01	E- 1-20	
152949-0-01	M-14		153426-0-01	Z-26		155499-0-01	D-42		155680-0-01	E- 1-24	
152950-0-01	M-14- 1		153482-0-01	J-62		155500-0-01	D-50		155681-0-01	E- 1-39	
152951-0-01	M-14- 7		153528-0-01	M-16		155501-0-01	C-37		155682-0-01	E- 1-42	
152952-0-01	M-14- 5		153529-0-01	M-17		155523-0-01	D- 5		155683-0-01	E- 1-40	
152955-0-01	M- 1- 2		153530-0-01	M- 7		155551-0-01	J-69		155684-0-01	E- 1-38	
152956-0-01	M- 1- 3		153531-0-01	M-53		155582-0-01	A- 3		155685-0-01	E- 1-10	
	M- 4		153562-0-01	M-54		155583-0-01	A- 3- 1		155686-0-01	E- 1-25	
152958-0-01	M- 1		153567-0-00	E- 1-32		155585-0-01	L-18		155687-0-01	E- 1- 7	
152959-0-01	M- 1- 1		153569-0-01	E- 1-33		155586-0-01	L-17		155693-0-01	R-38	
152960-0-01	M- 6		153570-0-01	E- 1-31		155587-0-01	L-14		155694-0-01	G-35	
152961-0-01	M-20		153571-0-01	E- 1-15		155589-0-01	C-16		155705-0-01	Q-31	
152962-0-01	M- 5		153596-0-01	J-23		155591-0-01	F-57		155706-0-01	Z-32	

Parts No.	Ref. No.	Remark	Parts No.	Ref. No.	Remark	Parts No.	Ref. No.	Remark	Parts No.	Ref. No.	Remark
155707-0-01	L-37		157208-0-01	E- 5- 1							
155708-0-01	D-47		157210-0-01	F-63							
155709-0-01	L-25		157212-0-01	Q-23							
155730-0-00	R-23		157237-0-01	b- 5							
155735-0-00	F-81		157245-0-01	F-55							
155739-0-00	F-64		157246-0-01	F-58							
155742-0-01	P-27		157247-0-01	F-19							
155743-0-01	P-29		157248-0-01	b- 6							
155744-0-00	R-91		157250-0-01	b- 7							
155745-0-00	N- 4		157251-0-01	b- 8							
155747-0-00	F-38		157713-0-01	b- 9							
155749-0-00	F-34		157714-0-01	b- 9- 3							
155750-0-00	R-96		157715-0-01	b-12							
155751-0-00	R-109		157716-0-01	b-14							
155755-0-00	F-15		157717-0-00	b- 9- 1							
155757-0-00	R-117		157718-0-01	b-10							
155758-0-00	R-81		157719-0-01	b-15							
155759-0-00	R-36		183151-0-01	P-30							
155761-0-00	R-86		340400-0-01	R-125							
155762-0-00	R-85		402887-0-01	B-58							
155763-0-00	R-82		407670-0-01	P-21							
155764-0-00	R-84		515907-0-00	L-34							
155765-0-00	R-83		525664-0-00	R-118							
155766-0-00	R-97		525907-0-00	R-119							
155789-0-00	R-98		552908-0-00	R-121							
155792-0-01	R-105		554482-0-00	R-120							
155793-0-01	R-103										
155794-0-01	R-126										
155816-0-00	R-113										
155819-0-00	F-62										
155820-0-00	a- 1										
155826-0-00	R-99										
155835-0-01	R-77										
156023-0-01	T-47										
156025-0-01	T-42										
156026-0-01	T-11										
156026-0-02	T-23										
156026-0-03	T-38										
156026-0-04	T-36										
156027-0-00	T-43										
156038-0-01	P-11										
156039-0-01	P- 9										
156040-0-01	P- 4										
156041-0-01	P-24										
156042-0-01	P-31										
156043-0-00	T-10										
156044-0-01	T-22										
156045-0-01	T-21										
156046-0-01	P-22										
156048-0-01	T- 7										
156073-0-01	E-16										
156076-0-01	E- 5										
156077-0-01	E- 5- 6										
156080-0-00	E- 5- 7										
156108-0-01	E- 5- 4										
156109-0-01	E- 5- 5										
156149-0-01	J-16										
156150-0-01	J-16										
156151-0-01	J-16										
156152-0-01	J-16										
156153-0-01	J-16										
156154-0-01	J-16										
156334-0-02	Z-20										
156674-0-01	Z-31- 3										
157001-0-01	E-14										
157002-0-01	E-11										
157003-0-01	E-10										
157005-1-02	Q-42										
157005-1-03	Q-43										
157206-0-01	N-56										

