

BAS-311HN

BAS-326H

ダイレクトドライブ
プログラム式電子ミシン

DIRECT DRIVE
PROGRAMMABLE ELECTRONIC PATTERN SEWER

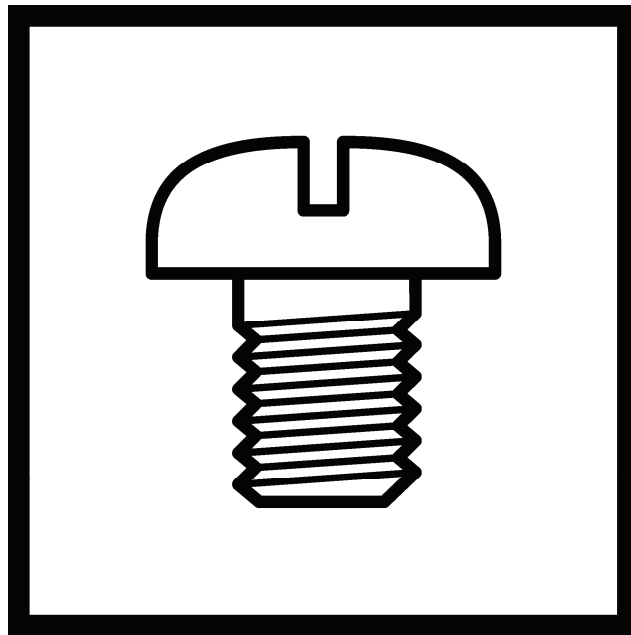

brother

型式板の見方

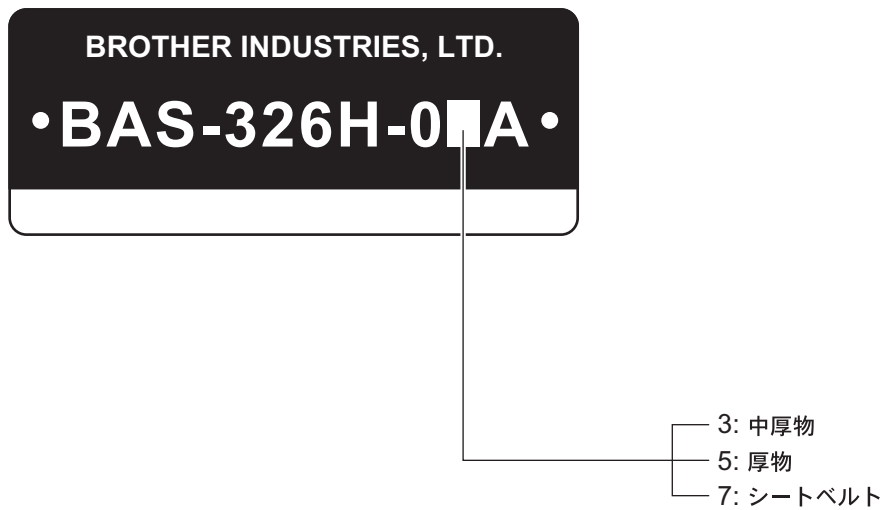
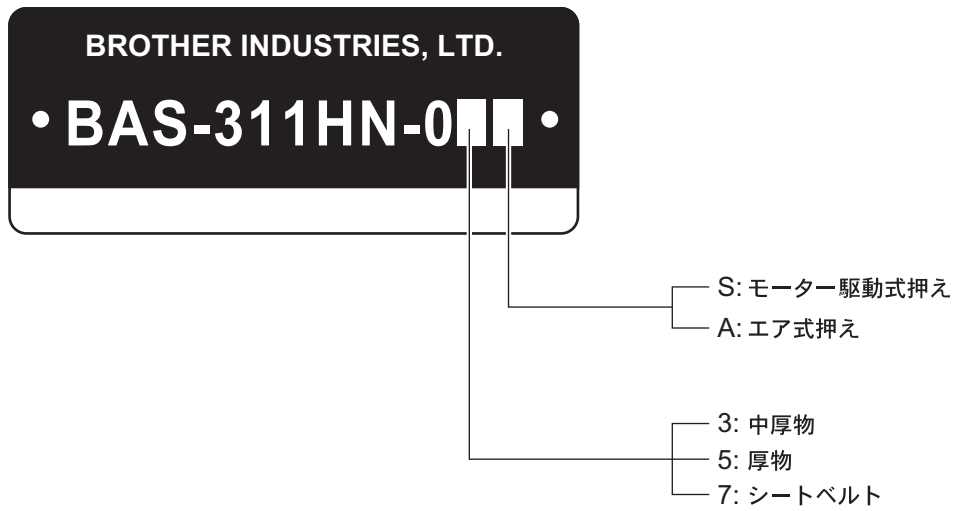

Description of model plate

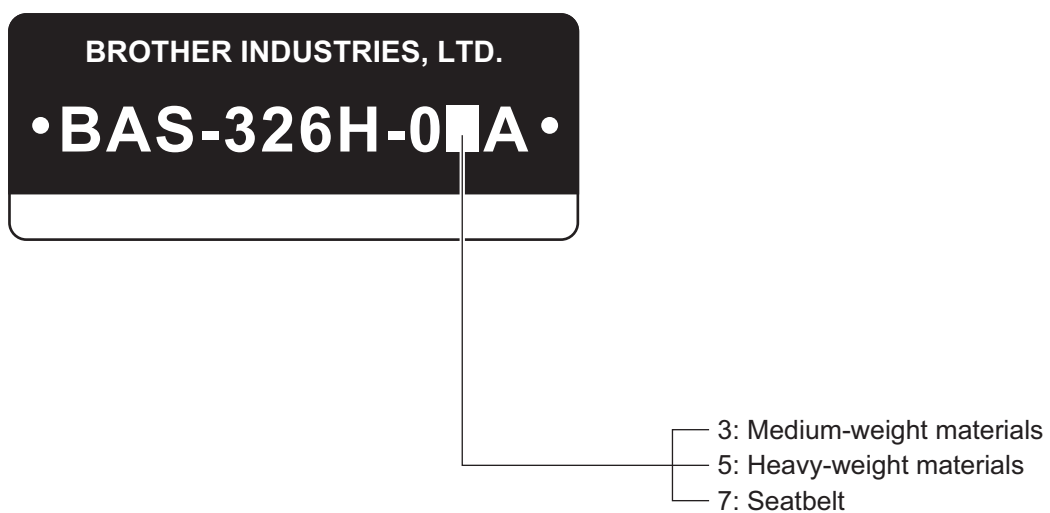
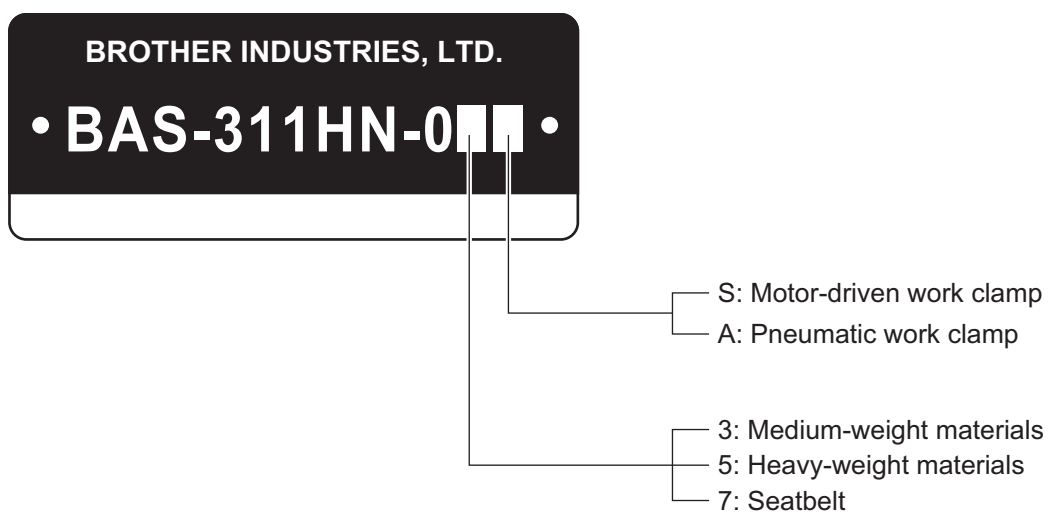

パーツブックご利用に際して

1. この本は、2015年7月のデータに基づいて作成されたものです。
2. 部品は予告なしに設計変更される場合があります。
3. 組単位で補給する部品は、破線で示してあります。
4. イラスト中で数字(REF.NO)に“+”がついている部品は、仕様により異なります。
詳細は、リストを参照してください。

目 次

A. 主体関係	1	L1. 糸ゆるめ関係 (デジタルテンションソレノイド).....	45
B. 上軸・針棒関係	3	L2. 糸ゆるめ関係 (糸ゆるめソレノイド).....	47
C1. 送り関係 (311HN)	5	M1. コントロールボックス関係	49
C2. 送り関係 (326H)	7	M2. コントロールボックス関係	51
C3. 送り関係 (311HN)	9	N. 空圧関係	53
C4. 送り関係 (326H)	11	P. 電装品関係	55
C5. 送り関係	13	Q. モーター・液晶パネル関係	57
C6. 送り関係 (311HN-0□S).....	15	R. 踏板関係	59
C7. 送り関係 (311HN-0□A).....	17	T1. 付属装置関係 (オプション部品)	61
C8. 送り関係 (326H).....	19	T2. 付属装置関係 (オプション部品)	63
C9. 送り関係 (オプション部品)	21	T3. 付属装置関係 (オプション部品)	65
D1. 押え上げ関係	23	Z. 付属品関係	67
D2. 押え上げ関係 (311HN-0□S).....	25	Wa. 警告ラベル	71
D3. 押え上げ関係 (-0□A).....	27	Sp. 仕様別部品一覧表.....	73
E. 下軸関係	29	Ga. ゲージ部品一覧表.....	75
F. 給油潤滑関係	31	索引	76
G. 糸通し関係	35		
H. 糸巻関係	37		
J. 糸切り関係	39		
K. 糸払い関係	43		

Notes for using this parts book

1. This book was prepared based on information available in July 2015.
2. Parts are subject to changes in design without prior notice.
3. Parts supplied as complete assemblies are circled by a dotted line.
4. The part which has the symbol "+" on its number (REF.NO) in the figure differs depending on the specification. For details, refer to the parts list.

CONTENTS

A. Machine body	1	L1. Tension release mechanism	
B. Upper shaft and needle bar mechanism	3	(Digital tension solenoid)	45
C1. Feed mechanism (311HN)	5	L2. Tension release mechanism	
C2. Feed mechanism (326H).....	7	(Tension release solenoid)	47
C3. Feed mechanism (311HN).....	9	M1. Control box	49
C4. Feed mechanism (326H).....	11	M2. Control box	51
C5. Feed mechanism	13	N. Air pressure mechanism	53
C6. Feed mechanism (311HN-0[S]).....	15	P. Power supply equipment	55
C7. Feed mechanism (311HN-0[A]).....	17	Q. Motor mechanism and LCD panel.....	57
C8. Feed mechanism (326H).....	19	R. Foot switch pedal mechanism	59
C9. Feed mechanism (Option parts)	21	T1. Attachment set	
D1. Work clamp lifter mechanism	23	(Option parts)	61
D2. Work clamp lifter mechanism (311HN-0[S])....	25	T2. Attachment set	
D3. Work clamp lifter mechanism (-0[A]).....	27	(Option parts)	63
E. Lower shaft mechanism	29	T3. Attachment set	
F. Lubrication	31	(Option parts)	65
G. Threading mechanism	35	Z. Accessories	67
H. Bobbin winder mechanism	37	Wa. Warning labels	71
J. Thread trimmer mechanism	39	Sp. Different parts list.....	73
K. Thread wiper mechanism	43	Ga. Gauge parts list.....	75
		Index	76

A. 主体関係 / Machine body

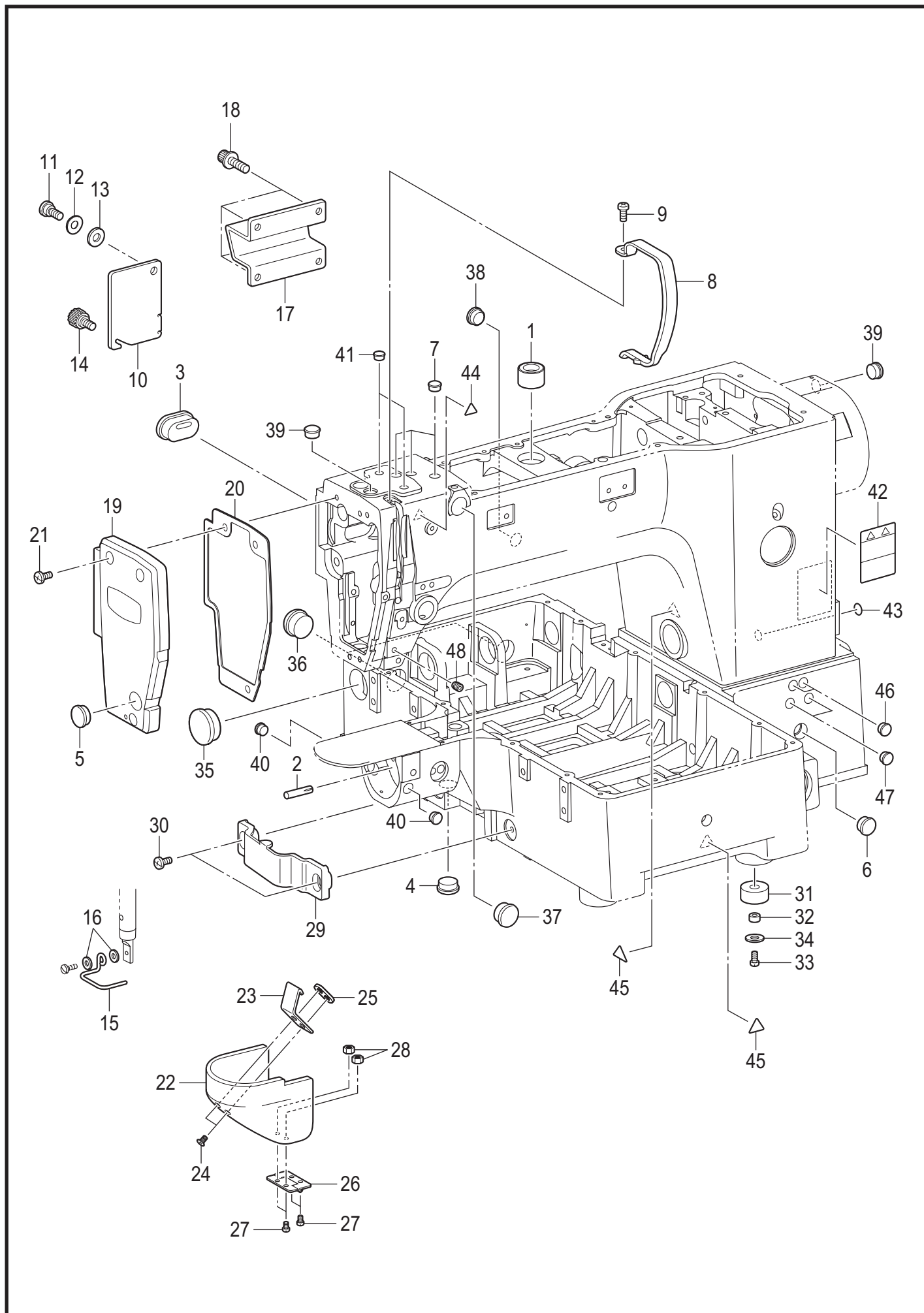

A. 主体関係 / Machine body

REF.NO	CODE	Q'TY	品名	NAME OF PARTS	RM
1	SA4594001	1	オサエアゲメタルU	BUSHING U	
2	117608001	1	ミゾツキピン	DOWEL PIN	
3	SA4596001	1	ゴムセン20-15	RUBBER CAP 20-15	
4	104449001	1	ゴムセン15.5	RUBBER CAP, 15.5	
5	104449001	1	ゴムセン15.5	RUBBER CAP, 15.5	
6	104449001	1	ゴムセン15.5	RUBBER CAP, 15.5	
7	104821001	3	ゴムセン10.5	RUBBER CAP, 10.5	
8	SB1277001	1	テンビンカバー	THREAD TAKE-UP LEVER COVER	
9	062401016	1	ナベコ4X10	SCREW PAN M4X10	
10	SA4604101	1	カンケツカバー	STEPPING COVER	
11	SA3306001	1	ダンネジ7-3	SHOULDER SCREW,7-3	
12	120265002	1	ナミバネザガネ	SPRING WASHER	
13	S07350002	1	ザガネ	WASHER PLAIN	
14	SB5978001	1	ツマミネジM5	GRIP SCREW M5	
15	SA8679001	1	フィンガーガード	FINGER GUARD	
16	SB2456001	2	ヒラザガネダイ3.5	WASHER PLAIN 3.5	
17	SA4605001	1	マクラ	HEAD REST	
18	S42446001	4	アナボルトザクミ 6×14	BOLT SOCKET (S/P WASHER) M6×14	
19	SA4600102	1	メンイタ	FACE PLATE	
20	SA4601001	1	メンイタパッキン	F-PLATE PACKING	
21	062061016	3	ナベコ6X10	SCREW PAN M6X10	
22	SA4603102	1	オオカマカバー	SHUTTLE RACE COVER	
23	SA6272001	1	オオカマカバー-フツクD	SHUTTLE RACE COVER HOOK D	
24	004300513	2	+サラコ3X5	SCREW, FLAT M3X5	
25	SA3264101	1	イタナツト	NUT PLATE	
26	SA6207001	1	チヨウバン	HINGE	
27	062300506	4	ナベコ3X5	SCREW PAN M3X5	
28	021300103	2	1シユナツト3	NUT, 1 M3	
29	SB4413001	1	イトキリカバー	THREAD TRIMMER COVER	
30	062501216	2	ナベコ5X12	SCREW PAN M5X12	
31	SB4385101	5	クッションゴム	RUBBER CUSHIOM	
32	SB4384001	5	カラー	COLLAR	
33	062401016	5	ナベコ4X10	SCREW PAN M4X10	
34	025040332	5	ヒラザガネダイ4	WASHER PLAIN L 4	
35	159163000	1	ゴムセン29	RUBBER CAP 29	
36	159150000	2	ゴムセン20.5	RUBBER CAP, 20.5	
37	S23337001	1	ゴムセン18.5	RUBBER CAP, 18.5	
38	104449001	1	ゴムセン15.5	RUBBER CAP, 15.5	
39	S20164001	2	ゴムセン13	RUBBER CAP, 13	
40	S44010001	2	ゴムセン11.5	RUBBER CAP, 11.5	
41	104450101	2	ゴムセン8	RUBBER CAP, 8	
42	SA9826001	1	ソウサチュウイラベル	LABEL CAUTION	
43	S37060001	1	アースマーク	LABEL, GROUNDING	
44	SA9957001	1	ワーニングマーク	INJURY MARK	
45	SA9957002	2	ワーニングマーク	INJURY MARK	
46	104821001	2	ゴムセン10.5	RUBBER CAP, 10.5	
47	104821001	2	ゴムセン10.5	RUBBER CAP, 10.5	
48	012500536	1	アナヒラ 5×5	SET SCREW SOCKET (FT) M5X5	

B. 上軸・針棒関係 / Upper shaft and needle bar mechanism

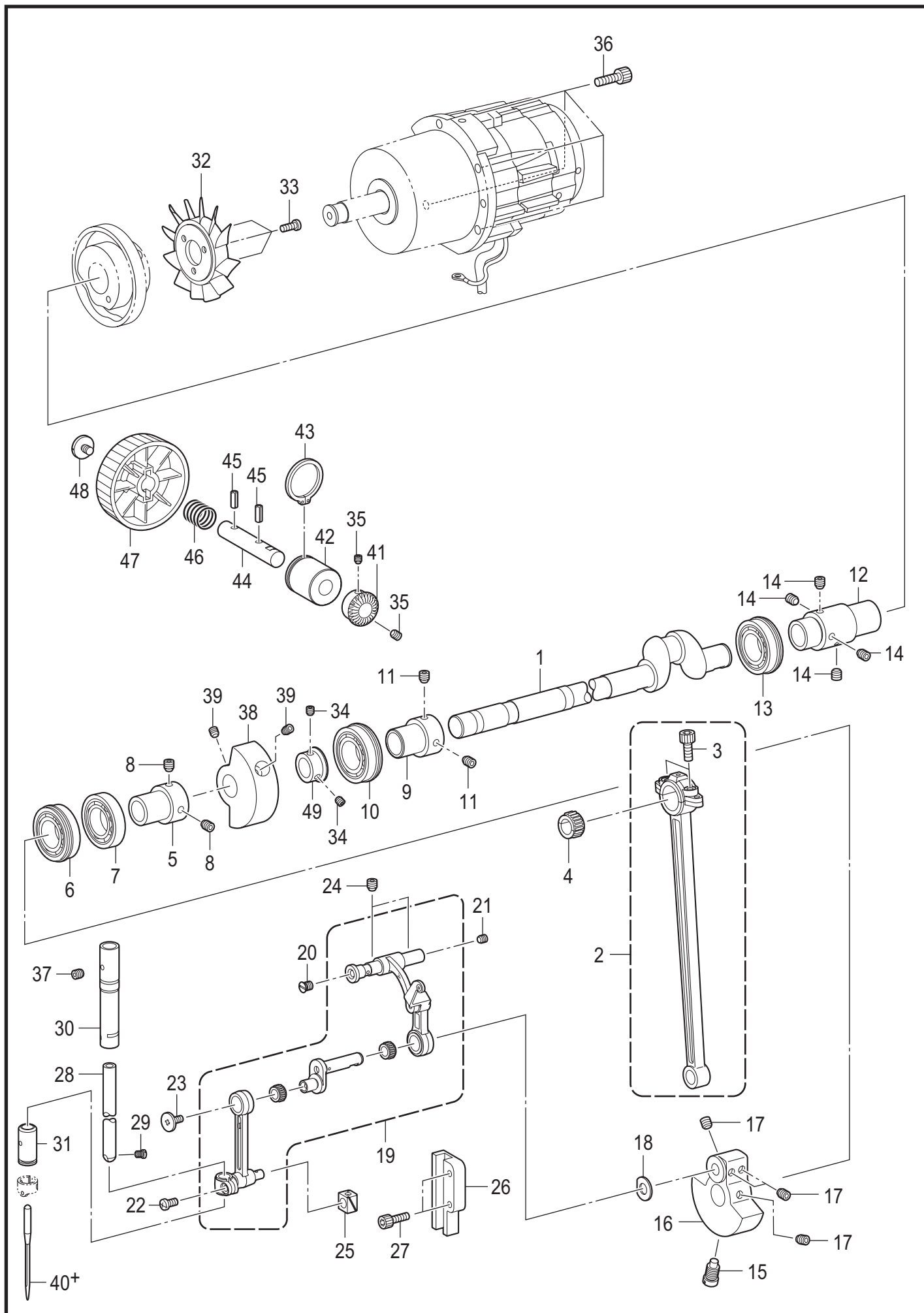

BAS-311HN/326H-123

B. 上軸 ・ 針棒関係 / Upper shaft and needle bar mechanism

REF.NO	CODE	Q'TY	品名	NAME OF PARTS	RM
1	SA4606201	1	ウワジク	UPPER SHUFT	
2	SA3499001	1	クランクロツドクミ	CRANK ROD ASSY	
3	018501636	2	アナボルト5X16	BOLT SOCKET M5X16	
4	SA4172001	1	ニードルベアリング 青色	NEEDLE BEARING BLUE	
4	SA4173001	1	ニードルベアリング 黒色	NEEDLE BEARING BLACK	
4	SA4174001	1	ニードルベアリング 灰色	NEEDLE BEARING GRAY	
4	SA4175001	1	ニードルベアリング 黄色	NEEDLE BEARING YELLOW	
5	SA3206001	1	ベアリングブツシュ	BALL BEARING BUSH	
6	SA4179001	1	タマジクウケ6904DDUNR	BALL BEARING 6904DDUNR	
7	SA4180001	1	タマジクウケ6904DDU	BALL BEARING 6904DDU	
8	S23651001	2	アナヒラ6X6ホソメ	SET SCREW SOCKET (FT) M6X6	
9	SA3206001	1	ベアリングブツシュ	BALL BEARING BUSH	
10	SA4177001	1	タマジクウケ6004DDUNR	BALL BEARING 6004DDUNR	
11	S23651001	2	アナヒラ6X6ホソメ	SET SCREW SOCKET (FT) M6X6	
12	SA4608101	1	ツギテG	JOINT G	
13	SA4178001	1	タマジクウケ6204DDUNR	BALL BEARING 6204DDUNR	
14	S23651001	4	アナヒラ6X6ホソメ	SET SCREW SOCKET (FT) M6X6	
15	S25235001	1	シメネジ8	SCREW M8	
16	SA4609101	1	ツリアイクランクG	THREAD TAKE-UP CRANK G	
17	S23651001	4	アナヒラ6X6ホソメ	SET SCREW SOCKET (FT) M6X6	
18	110367001	1	ザガネ	WASHER, PLAIN SPECIAL 8	
19	SA6182001	1	ハリボウレンカンFKクミ	THREAD TAKE-UP LEVER FK SET	
20	SA2958001	1	サラネジ5X6	SCREW FLAT M5X6	
21	012500536	1	アナヒラ5X5	SET SCREW SOCKET (FT) M5X5	
22	062400816	1	ナベコ4X8	SCREW PAN M4X8	
23	145465001	1	シメネジ3.57L	SCREW, SM3.57-40X6 L	
24	012060636	2	アナヒラ6X6	SET SCREW SOCKET (FT) M6X6	
25	142211001	1	カクコマ	SLIDE BLOCK	
26	SA3528001	1	カクコマアンナイB	SLIDE BLOCK GUIDE	
27	018401636	2	アナボルト4X16	BOLT SOCKET M4X16	
28	SA4622001	1	ハリボウ	NEEDLE BAR	
29	144458001	1	アタマツキトメネジ3.57	SET SCREW SM3.57-40X4.5	
30	SA4666001	1	ハリボウメタルUK	NEEDLE BAR BUSH UK	
31	SA3224001	1	ハリボウメタルD	NEEDLE BAR BUSH D	
32	S38713100	1	ファン	FAN	
33	062400816	3	ナベコ4X8	SCREW PAN M4X8	
34	012500536	2	アナヒラ5X5	SET SCREW SOCKET (FT) M5X5	
35	012500536	2	アナヒラ5X5	SET SCREW SOCKET (FT) M5X5	
36	018501636	4	アナボルト5X16	BOLT SOCKET M5X16	
37	012060536	1	アナヒラ6X5	SET SCREW, SOCKET (FT) M6X5	
38	SA4797101	1	イトマキウドウリン	DRIVING WHEEL B-WINDER	
39	S23651001	2	アナヒラ 6 × 6 ホソメ	SET SCREW SOCKET (FT) M6X6	
40+			<-03□用> ミシンハリDPX5・・・(#16)	<For -03□> NEEDLE, DPX5...(#16)	
40+			<-05□用> ミシンハリDPX17・・・(#19)	<For -05□> NEEDLE, DPX17...(#19)	
40+			<-07□用> ミシンハリDPX17・・・(#25)	<For -07□> NEEDLE, DPX17...(#25)	
41	SB4270001	1	プーリギヤL	PULLEY GEAR L	
42	SB1038001	1	プーリメタル	PULLEY BUSH	
43	048280142	1	トメワジクヨウC28	RETAINING RING EXTERNAL C28	
44	SB2097001	1	プーリジク	PULLEY SHAFT	
45	047402042	2	スプリングピンAW4	PIN SPRING ROLL AW4	
46	SB1041001	1	プーリバネ	PULLEY SPRING	
47	SB0910201	1	プーリ	PULLEY	
48	SB1040001	1	プーリネジ	SCREW	
49	SB4500001	1	プーリギヤR	PULLEY GEAR R	

C1. 送り関係 (BAS-311HN) / Feed mechanism (BAS-311HN)

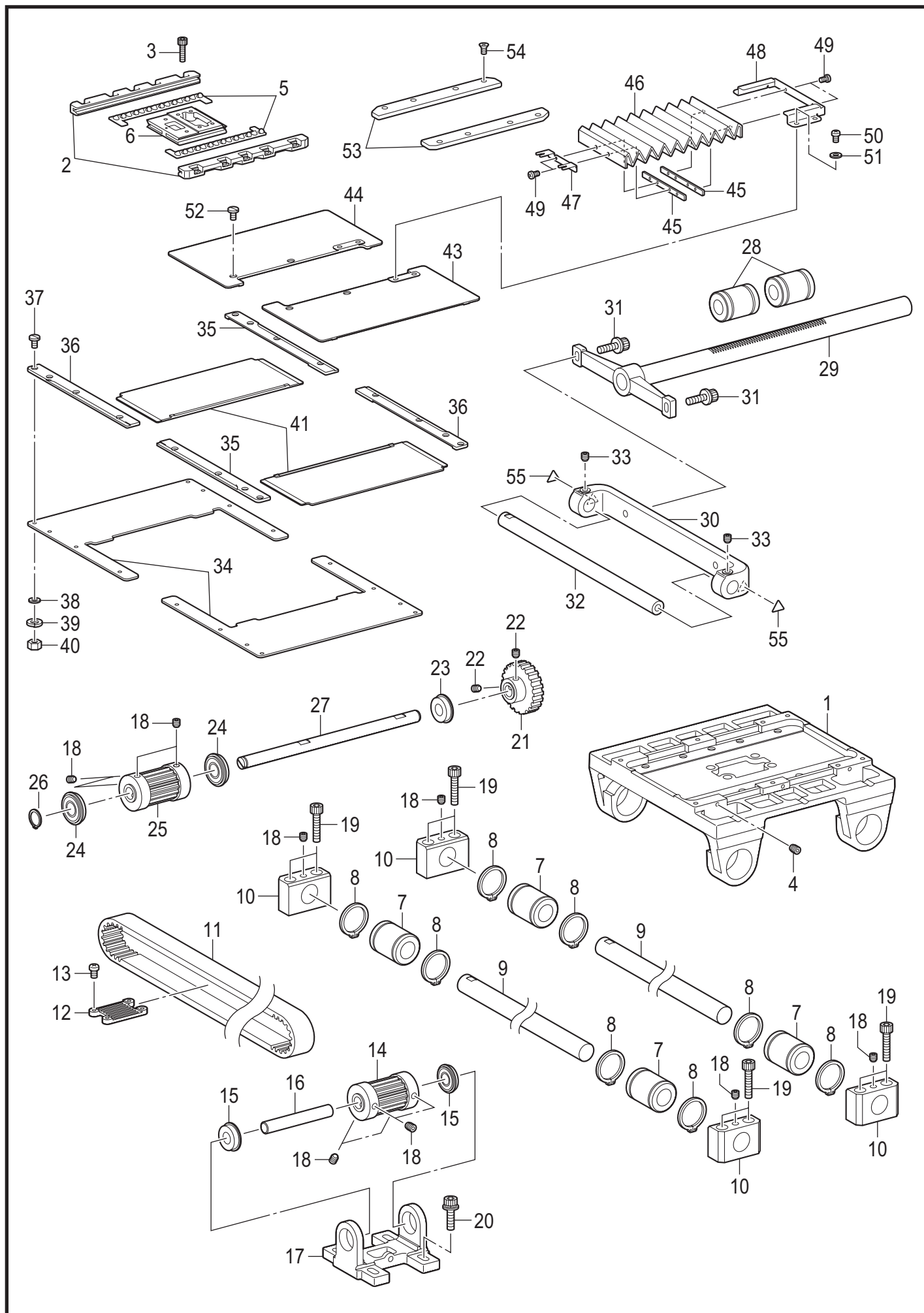

C1. 送り関係 (BAS-311HN) / Feed mechanism (BAS-311HN)

REF.NO	CODE	Q'TY	品名	NAME OF PARTS	RM
1	SB4344101	1	オクリダイコクミ	X-FEED BRACKET S ASSY	
2	SB4186201	2	Yオクリアンナイ	Y-FEED GUIDE	
3	018501036	10	アナボルト5X10	BOLT SOCKET M5X10	
4	012400636	6	アナヒラ4X6	SET SCREW SOCKET (FT) M4X6	
5	SB6488001	2	クロスローラー	CROSS ROLLER	
6	SB4185501	1	Yオクリダイ	Y-FEED BASE	
7	SA5593001	4	ボールブツシュ	LINEAR BUSH 16	
8	SB4351001	8	トメワジクヨウC28	RETAINING RING EXTERNAL C28	
9	SB4184001	2	Xオクリジク	X SHAFT	
10	SB4402001	4	Xオクリジクホルダ	X-FEED SHAFT HOLDER	
11	SB4432001	1	タイミングベルト	TIMING BELT	
12	SB4341001	1	ベルトオサエイタ	BELT WORK CLAMP PLATE	
13	062400816	4	ナベコ4X8	SCREW PAN M4X8	
14	SB4406001	1	タイミングプーリ	TIMING PULLEY	
15	SA4647001	2	タマジクウケ6900ZZNR	BALL BEARING 6900ZZNR	
16	SB4339001	1	Xプーリシテンジク	X-PULLEY FULCRUM SHAFT	
17	SB4340001	1	Xプーリブラケット	X-PULLEY BRACKET	
18	012060636	8	アナヒラ6X6	SET SCREW SOCKET (FT) M6X6	
19	018063036	8	アナボルト6X30	BOLT SOCKET M6X30	
20	SA2972001	4	アナボルトザクミ6X18	BOLT SOCKET(S/P WASHER)M6X18	
21	SB4282001	1	Xオクリギア	X-FEED GEAR	
22	012060636	6	アナヒラ6X6	SET SCREW SOCKET (FT) M6X6	
23	SA4647001	1	タマジクウケ6900ZZNR	BALL BEARING 6900ZZNR	
24	SB4469001	2	タマジクウケ6000ZZNR	BALL BEARING 6000ZZNR	
25	SB4406001	1	タイミングプーリ	TIMING PULLEY	
26	048100142	1	トメワジクヨウC10	RETAINING RING EXTERNAL C10	
27	SB4338001	1	Xプーリドウジク	X-PULLEY DRIVING SHAFT	
28	SA5593001	2	ボールブツシュ	LINEAR BUSH 16	
29	SB4281101	1	Yラックジククミ	Y-RACK SHAFT ASSY	
30	SB4337001	1	Xオクリジクササエ	X-FEED SHAFT SUPPORT	
31	S42446001	2	アナボルトザクミ6X14	BOLT SOCKET (S/P WASHER)M6X14	
32	SB4335001	1	Xオクリジク	X-FEED SHAFT	
33	012060636	2	アナヒラ6X6	SET SCREW SOCKET (FT) M6X6	
34	SB4366001	2	コテイカバー	FIXATION COVER	
35	SB4357001	2	カバーレールR	COVER RAIL R	
36	SB4356001	2	カバーレールL	COVER RAIL L	
37	SA3538001	16	シメネジ4X8	SCREW,M4X8	
38	SB3848001	4	ヒラザガネチュウ4	WASHER_PLAIN_M_4	
39	028040246	4	バネザガネ2-4	WASHER SPRING 2-4	
40	021400216	4	2シュナット4	NUT 2 M4	
41	SB4360001	2	ソトカバー	OUTSIDE COVER	
43	SB5072001	1	ウチカバーRクミ	INSIDE COVER R ASSY	
44	SB5073001	1	ウチカバーLクミ	INSIDE COVER L ASSY	
45	SB4362001	2	ジャバラナット	BELLOW NUT	
46	SB4363001	1	ジャバラ	BELLOW	
47	SB4365101	1	ジャバラオサエF	BELLOW PRESSER F	
48	SB4361001	1	ジャバラオサエR	BELLOW PRESSER R	
49	062300416	4	ナベコ3X4	SCREW PAN M3X4	
50	062401216	4	ナベコ4X12	SCREW PAN M4X12	
51	SB3848001	4	ヒラザガネチュウ4	WASHER_PLAIN_M_4	
52	SA3538001	4	シメネジ4X8	SCREW,M4X8	
53	SB4689201	2	Yオクリアンナイカバー	Y-FEED GUIDE COVER	
54	SA6308001	8	0サラコ3シュ2X4	SCREW FLAT #0 M2X4	
55	SA9957001	2	ワーニングマーク	INJURY MARK	

C2. 送り関係 (BAS-326H) / Feed mechanism (BAS-326H)

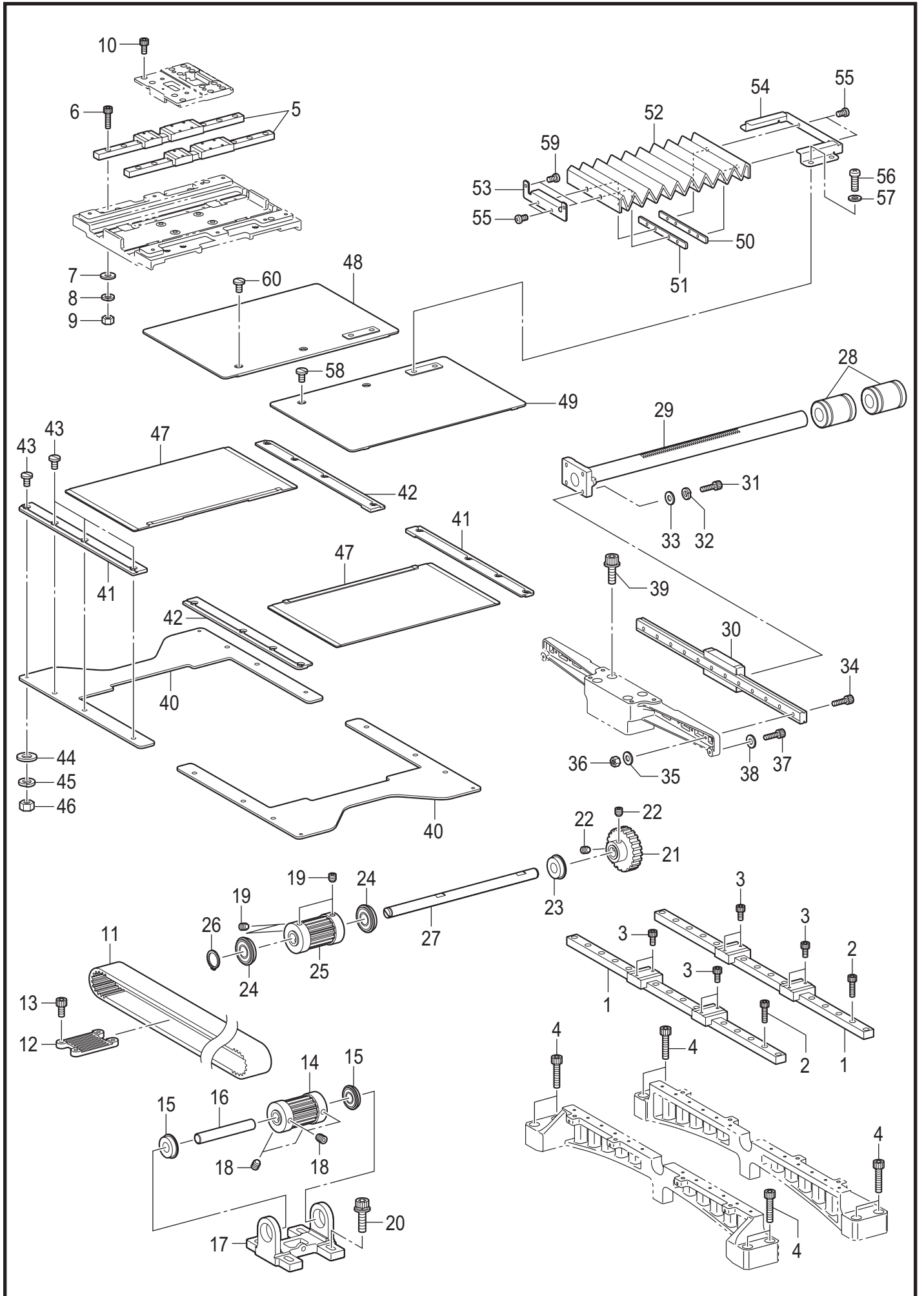

C2. 送り関係 (BAS-326H) / Feed mechanism (BAS-326H)

REF.NO	CODE	Q'TY	品名	NAME OF PARTS	RM
1	SB5968001	2	リニアガイド13X384	LINEAR GUIDE 13X384	
2	018301036	24	アナボルト3X10	BOLT SOCKET M3X10	
3	018300536	8	アナボルト3×5	BOLT SOCKET M3X5	
4	018062536	8	アナボルト6X25	BOLT SOCKET M6X25	
5	SB5967001	2	リニアガイド10X182	LINEAR GUIDE 10X182	
6	018301036	12	アナボルト3X10	BOLT SOCKET M3X10	
7	SB3847001	12	ヒラザガネチュウ3	WASHER_PLAIN_M_3	
8	028030246	12	バネザガネ2-3	WASHER SPRING 2-3	
9	021300103	12	1シュナツト3	NUT, 1 M3	
10	018300536	12	アナボルト3×5	BOLT SOCKET M3X5	
11	SB5966001	1	タイミングベルト	TIMING BELT	
12	SB4341001	1	ベルトオサエイタ	BELT WORK CLAMP PLATE	
13	018400836	4	アナボルト4X8	BOLT SOCKET M4X8	
14	SB4406001	1	タイミングプーリ	TIMING PULLEY	
15	SA4647001	2	タマジクウケ6900ZZNR	BALL BEARING 6900ZZNR	
16	SB4339001	1	Xプーリシテンジク	X-PULLEY FULCRUM SHAFT	
17	SB4340001	1	Xプーリブラケット	X-PULLEY BRACKET	
18	012060636	4	アナヒラ6X6	SET SCREW SOCKET (FT) M6X6	
19	012060636	4	アナヒラ6X6	SET SCREW SOCKET (FT) M6X6	
20	SA2972001	4	アナボルトザクミ6X18	BOLT SOCKET(S/P WASHER)M6X18	
21	SB4282001	1	Xオクリギア	X-FEED GEAR	
22	012060636	2	アナヒラ6X6	SET SCREW SOCKET (FT) M6X6	
23	SA4647001	1	タマジクウケ6900ZZNR	BALL BEARING 6900ZZNR	
24	SB4469001	2	タマジクウケ6000ZZNR	BALL BEARING 6000ZZNR	
25	SB4406001	1	タイミングプーリ	TIMING PULLEY	
26	048100142	1	トメワジクヨウC10	RETAINING RING EXTERNAL C10	
27	SB4338001	1	Xプーリクドウジク	X-PULLEY DRIVING SHAFT	
28	SA5593001	2	ボールブツシュ	LINEAR BUSH 16	
29	SB5848001	1	Yラックジククミ	Y RACK SHAFT ASSY	
30	SB5969001	1	リニアガイド13X300	LINEAR GUIDE 13X300	
31	018301236	4	アナボルト3X12	BOLT SOCKET M3X12	
32	028030246	4	バネザガネ2-3	WASHER SPRING 2-3	
33	SB3847001	4	ヒラザガネチュウ3	WASHER_PLAIN_M_3	
34	018301036	6	アナボルト3X10	BOLT SOCKET M3X10	
35	SB3847001	6	ヒラザガネチュウ3	WASHER_PLAIN_M_3	
36	021300103	6	1シュナツト3	NUT, 1 M3	
37	018301036	2	アナボルト3X10	BOLT SOCKET M3X10	
38	SB3847001	2	ヒラザガネチュウ3	WASHER_PLAIN_M_3	
39	S55487001	4	アナボルトザクミ5X16	BOLT SOCKET (S/P WASHER)M5X16	
40	SB5931001	2	コテイカバー	FIXATION COVER	
41	SB5932101	2	カバーレールL	COVER RAIL L	
42	SB5933101	2	カバーレールR	COVER RAIL R	
43	SA3538001	16	シメネジ4X8	SCREW,M4X8	
44	SB3848001	4	ヒラザガネチュウ4	WASHER_PLAIN_M_4	
45	028040246	4	バネザガネ2-4	WASHER SPRING 2-4	
46	021400216	4	2シュナツト4	NUT 2 M4	
47	SB5934101	2	ソトカバー	OUTSIDE COVER	
48	SB5974001	1	ウチカバーLクミ	INSIDE COVER L ASSY	
49	SB5975001	1	ウチカバーRクミ	INSIDE COVER R ASSY	
50	SB4362001	1	ジャバラナット	BELLOW NUT	
51	SB4362001	1	ジャバラナット	BELLOW NUT	
52	SB5077001	1	ジャバラ	BELLOW	
53	SB5937001	1	ジャバラオサエF	BELLOW PRESSER F	
54	SB4361001	1	ジャバラオサエR	BELLOW PRESSER R	
55	062300416	4	ナベコ3X4	SCREW PAN M3X4	
56	062401216	4	ナベコ4X12	SCREW PAN M4X12	
57	SB3848001	4	ヒラザガネチュウ4	WASHER_PLAIN_M_4	
58	SA3538001	2	シメネジ4X8	SCREW,M4X8	
59	SA9191001	2	シメネジM3X5.5	SCREW M3X5.5	
60	SA3538001	2	シメネジ4X8	SCREW,M4X8	

C3. 送り関係 (BAS-311HN) / Feed mechanism (BAS-311HN)

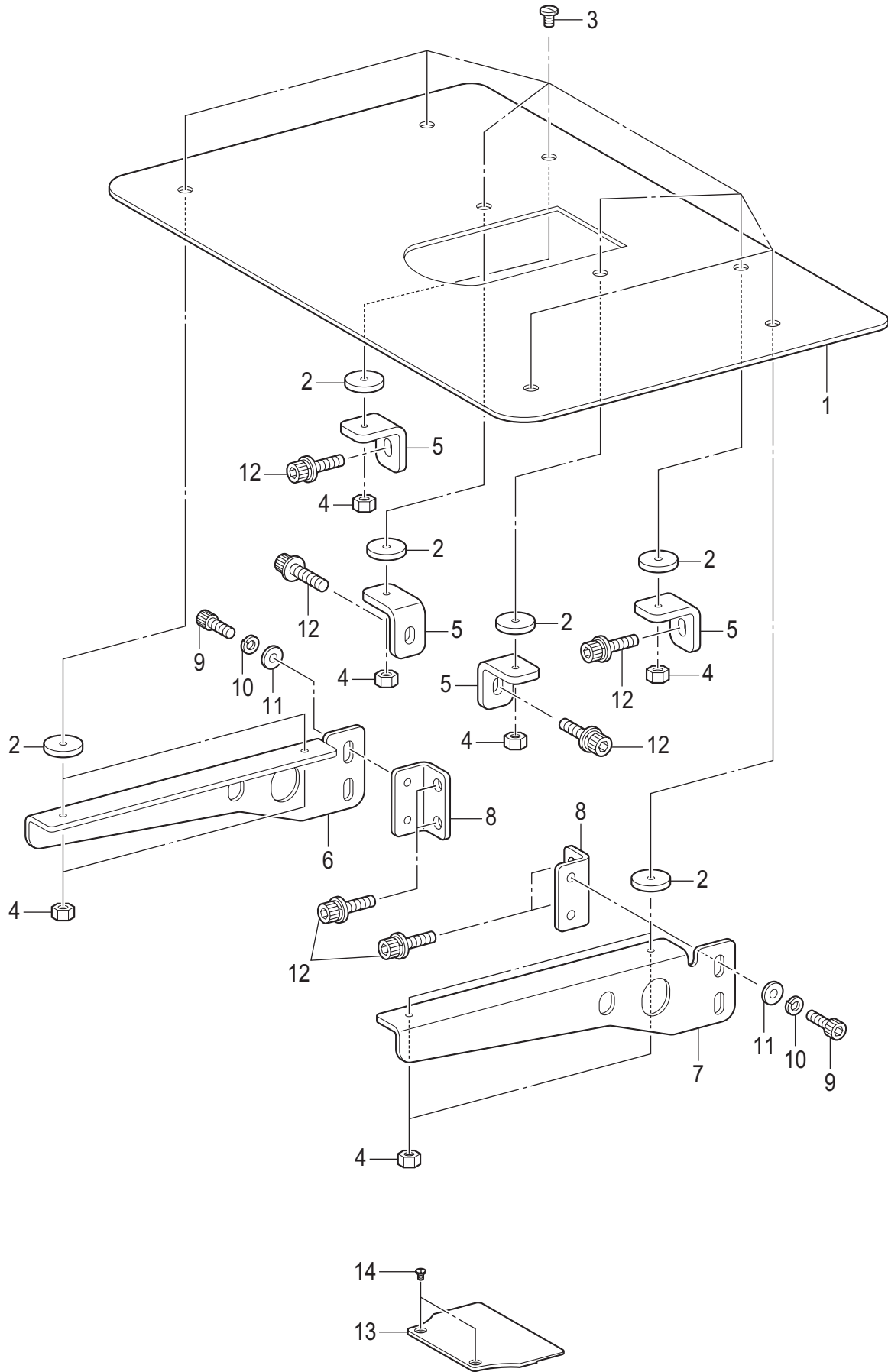

C3. 送り関係 (BAS-311HN) / Feed mechanism (BAS-311HN)

REF.NO	CODE	Q'TY	品名	NAME OF PARTS	RM
1	SB4183101	1	ハリイタホジョイタ	AUXILIARY PLATE	
2	SA4677101	8	ホジョイタクッション	AUXILIARY PLATE CUSHION	
3	SA8560001	8	シメネジ4X12	SCREW M4X12	
4	021400216	8	2シュナット4	NUT 2 M4	
5	SA4676201	4	ホジョイタブラケット	AUXILIARY PLATE BRACKET	
6	SB4407101	1	ホジョイタブラケットL	AUXILIARY PLATE BRACKET L	
7	SB4408101	1	ホジョイタブラケットR	AUXILIARY PLATE BRACKET R	
8	SB4409001	2	ホジョイタブラケットM	AUXILIARY PLATE BRACKET M	
9	018501036	4	アナボルト5X10	BOLT SOCKET M5X10	
10	028050246	4	バネザガネ2-5	WASHER SPRING 2-5	
11	146354002	4	ザガネ	WASHER, PLAIN 5	
12	S42446001	8	アナボルトザクミ6X14	BOLT SOCKET (S/P WASHER)M6X14	
13	SA6594001	1	ショートハリイタホジョイタ	SHORT AUXILIARY PLATE	
14	SA3538001	2	シメネジ4X8	SCREW,M4X8	

C4. 送り関係 (BAS-326H) / Feed mechanism (BAS-326H)

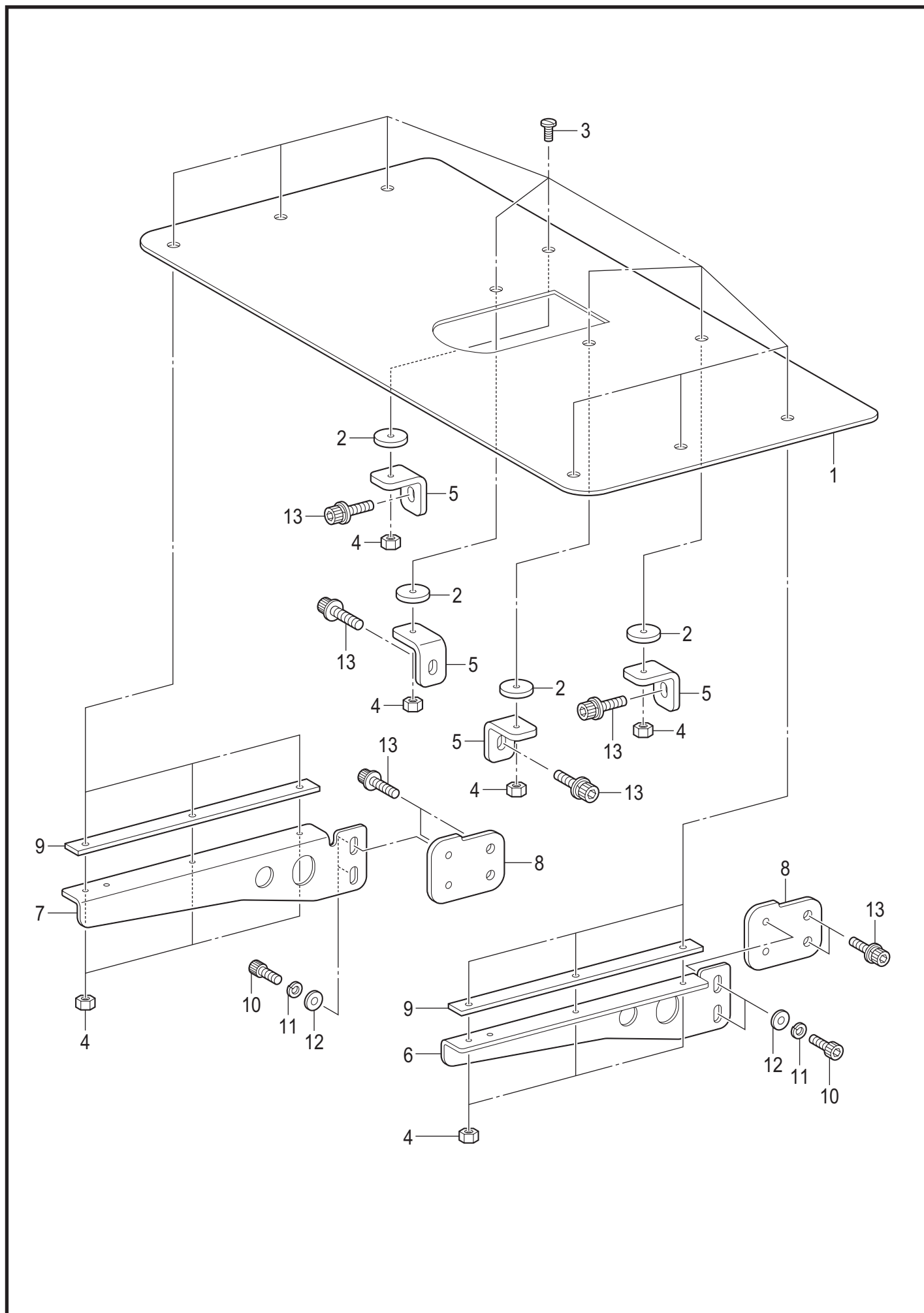

BAS-326H-202

C4. 送り関係 (BAS-326H) / Feed mechanism (BAS-326H)

REF.NO	CODE	Q'TY	品名	NAME OF PARTS	RM
1	SB5925001	1	ハリイタホジョイタ	AUXILIARY PLATE	
2	SA4677101	4	ホジョイタクッション	AUXILIARY PLATE CUSHION	
3	SA8560001	10	シメネジ4X12	SCREW M4X12	
4	021400216	10	2シュナット4	NUT 2 M4	
5	SA4676201	4	ホジョイタブラケット	AUXILIARY PLATE BRACKET	
6	SB4407101	1	ホジョイタブラケットL	AUXILIARY PLATE BRACKET L	
7	SB4408101	1	ホジョイタブラケットR	AUXILIARY PLATE BRACKET R	
8	SB5926001	2	ハリイタホジョイタブラケット	AUXILIARY PLATE BRACKET	
9	SA8672001	2	ホジョイタクッションB	AUXILIARY PLATE CUSHION B	
10	018501036	4	アナボルト5X10	BOLT SOCKET M5X10	
11	028050246	4	バネザガネ2-5	WASHER SPRING 2-5	
12	146354002	4	ザガネ	WASHER, PLAIN 5	
13	S42446001	8	アナボルトザクミ6X14	BOLT SOCKET (S/P WASHER)M6X14	

C5. 送り関係 / Feed mechanism

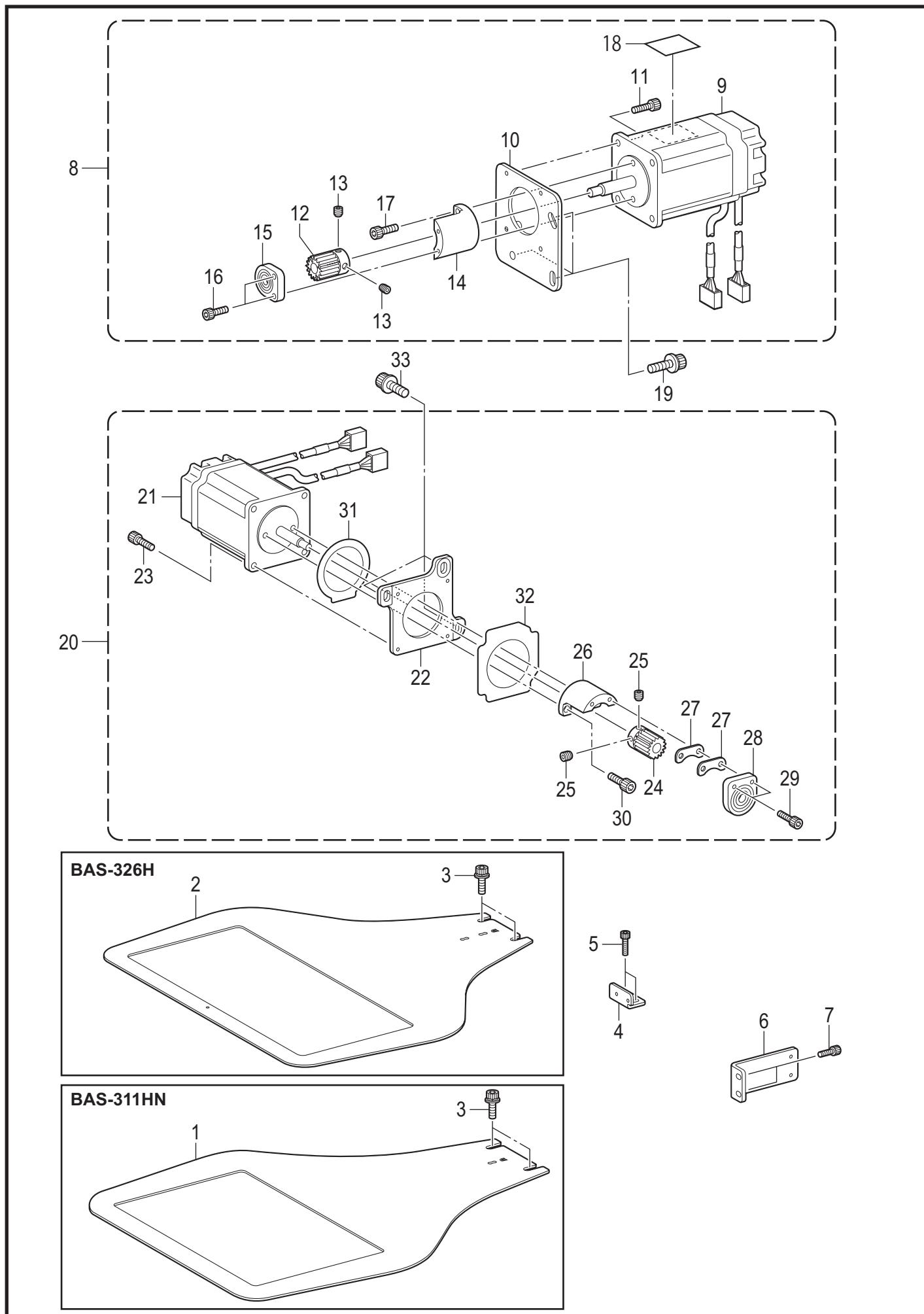

C5. 送り関係 / Feed mechanism

REF.NO	CODE	Q'TY	品名	NAME OF PARTS	RM
1	SB4346001	1	オクリイタ311H	FEED PLATE 311H	
2	SA4852201	1	220X100オクリイタ	FEED PLATE 220X100	
3	S55484001	2	アナボルトザクミ5X10	BOLT SOCKET (S/P WASHER)M5X10	
4	SB4343001	1	Xセンサトリツケイタ	X SENSOR PLATE	
5	018400836	2	アナボルト4X8	BOLT SOCKET M4X8	
6	SB4342001	1	Yセンサトリツケイタ	Y SENSOR PLATE	
7	018400836	2	アナボルト4X8	BOLT SOCKET M4X8	
8	SB4458001	1	Xオクリモータオオクミ	X-FEED MOTOR L ASSY	
9	SB4275001	1	パルスモータXクミ	PULSE MOTOR ASSY X	
10	SB4334001	1	Xモータトリツケイタ	X MOTOR SETTING PLATE	
11	018401036	4	アナボルト4X10	BOLT SOCKET M4X10	
12	SA3707101	1	クドウギヤ16	GEAR 16	
13	012060536	2	アナヒラ6X5	SET SCREW, SOCKET (FT) M6X5	
14	SA6450101	1	ベアリングホルダベース	BEARING HOLDER BASE	
15	SA6451101	1	ベアリングホルダクミ	BEARING HOLDER ASSY	
16	018401036	2	アナボルト4X10	BOLT SOCKET M4X10	
17	018501036	2	アナボルト5X10	BOLT SOCKET M5X10	
18	SA4224001	1	マークチュウイ 30×40	MARK ATTENTION 30×40	
19	S42446001	3	アナボルトザクミ6X14	BOLT SOCKET (S/P WASHER)M6X14	
20	SB4459201	1	Yオクリモータオオクミ	Y-FEED MOTOR L ASSY	
21	SB4276001	1	パルスモータYクミ	PULSE MOTOR ASSY Y	
22	SB4188001	1	Yモータトリツケイタ	Y MOTOR SETTING PLATE	
23	018401036	4	アナボルト4X10	BOLT SOCKET M4X10	
24	SA4197101	1	オクリギア	FEED GEAR	
25	012060536	2	アナヒラ6X5	SET SCREW, SOCKET (FT) M6X5	
26	SA6450101	1	ベアリングホルダベース	BEARING HOLDER BASE	
27	SB4364101	2	ベアリングホルダスペーサ	BEARING HOLDER SPACER	
28	SA6451101	1	ベアリングホルダクミ	BEARING HOLDER ASSY	
29	018401236	2	アナボルト4X12	BOLT SOCKET M4X12	
30	018501036	2	アナボルト5X10	BOLT SOCKET M5X10	
31	SB5071001	1	YモータトリツケイタパッキンM	Y-PLATE PACKING M	
32	SB4181001	1	Yモータトリツケイタパッキン	Y-PLATE PACKING	
33	S55485001	3	アナボルトザクミ5X12	BOLT SOCKET (S/P WASHER)M5X12	

C6. 送り関係 (BAS-311HN-0□S) / Feed mechanism (BAS-311HN-0□S)

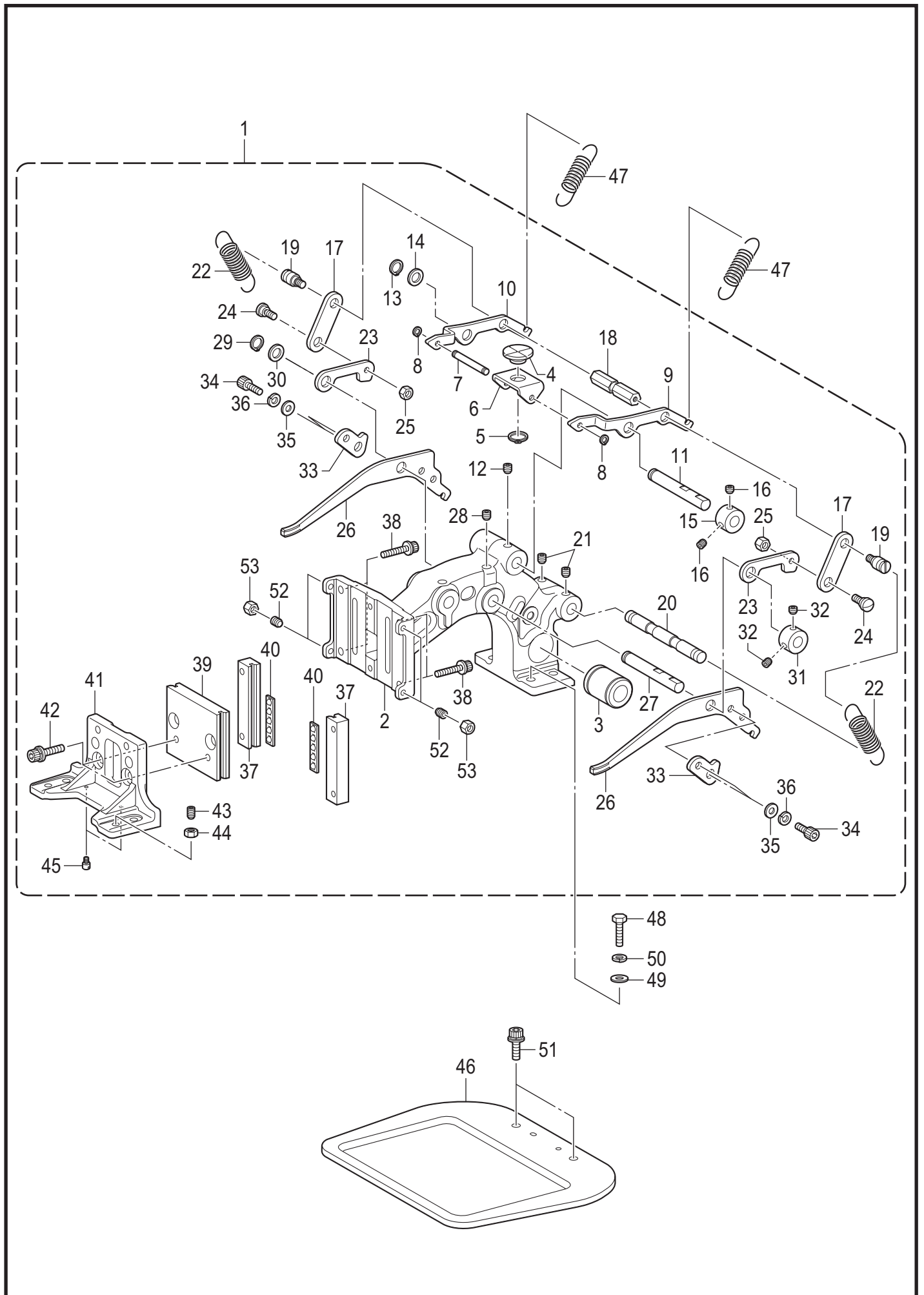

C6. 送り関係 (BAS-311HN-0[S]) / Feed mechanism (BAS-311HN-0[S])

REF.NO	CODE	Q'TY	品名	NAME OF PARTS	RM
1	SB4433001	1	オサエウデ311Hクミ	WORK CLAMP ASSY 311H	
2	SB4404001	1	オサエウデ	WORK CLAMP ARM	
3	S35183000	1	リニアブツシュ12	LINEAR BUSH, 12	
4	SA4687101	1	スライダ-	SLIDER	
5	048100142	1	トメワジクヨウC10	RETAINING RING EXTERNAL C10	
6	SA4688001	1	スライダ-ササエ	SUPPORT SLIDER	
7	SA4689001	1	スライダ-ササエジク	SUPPORT SHAFT SLIDER	
8	048040142	2	トメワジクヨウC4	RETAINING RING EXTERNAL C4	
9	SB4368001	1	オサエアゲレバーR	WORK CLAMP LIFTER LEVER R	
10	SB4367001	1	オサエアゲレバーL	WORK CLAMP LIFTER LEVER L	
11	SA4692001	1	オサエウデレバー-ジク	WORK CLAMP LIFTER SHAFT	
12	012060636	1	アナヒラ6X6	SET SCREW SOCKET (FT) M6X6	
13	048080142	1	トメワジクヨウC8	RETAINING RING EXTERNAL C8	
14	110367001	1	ザガネ	WASHER, PLAIN SPECIAL 8	
15	SA3231001	1	セツトカラ-B	SET SCREW COLLAR,B	
16	012060536	2	アナヒラ6X5	SET SCREW, SOCKET (FT) M6X5	
17	SB4414001	2	レンカン	CONNECTING ROD	
18	SA4693001	1	バネカケジクA	SPRING HOLDER SHAFT A	
19	SB4375001	2	バネカケ	SPRING HOLDER	
20	SB4374001	1	バネカケジク	SPRING HOLDER SHAFT	
21	012060636	2	アナヒラ6X6	SET SCREW SOCKET (FT) M6X6	
22	SB4376001	2	モドシバネ	SPRING	
23	SB4421001	2	レンケツリンク	CONNECTING LINK	
24	SB4422001	2	ダンネジM4	SHOULDER SCREW M4	
25	021400216	2	2シュナット4	NUT 2 M4	
26	SB4377001	2	オサエウデレバー-	WORK CLAMP LIFTER	
27	SA4692001	1	オサエウデレバー-ジク	WORK CLAMP LIFTER SHAFT	
28	012060636	1	アナヒラ6X6	SET SCREW SOCKET (FT) M6X6	
29	048080142	1	トメワジクヨウC8	RETAINING RING EXTERNAL C8	
30	110367001	1	ザガネ	WASHER, PLAIN SPECIAL 8	
31	SA3231001	1	セツトカラ-B	SET SCREW COLLAR,B	
32	012060536	2	アナヒラ6X5	SET SCREW, SOCKET (FT) M6X5	
33	SB4420001	2	ストッパー	STOPPER	
34	018500836	4	アナボルト5X8	BOLT SOCKET M5X8	
35	SB3849001	4	ヒラザガネチュウ5	WASHER_PLAIN_M_5	
36	028050246	4	バネザガネ2-5	WASHER SPRING 2-5	
37	SA4864001	2	オサエアシアンナイBクミ	WORK CLAMP GUIDE B ASSY	
38	S55482001	4	アナボルトザクミ4X14	BOLT SOCKET (S/P WASHER)M4X14	
39	SB2131001	1	オサエアシスライダ300G	WORK CLAMP SLIDER 300G	
40	SA4706101	2	オサエアシリテーナクミ	WORK CLAMP RETAINER ASSY	
41	SB4453001	1	オサエアシクミ	WORK CLAMP ASSY	
42	S55485001	2	アナボルトザクミ5X12	BOLT SOCKET (S/P WASHER)M5X12	
43	012501031	2	アナヒラ5X10	SET SCREW SOCKET (FT) M5X10	
44	021500216	2	2シュナット5	NUT 2 M5	
45	SA4709001	2	イチギメダンネジ	SHOULDER SCREW	
46	SB4457001	1	オサエイタ311Hクミ	WORK CLAMP 311H ASSY	
47	SB4373001	2	オサエバネ	WORK CLAMP SPRING	
48	017501616	4	ボルト5X16	BOLT M5X16	
49	SB3849001	4	ヒラザガネチュウ5	WASHER_PLAIN_M_5	
50	028050246	4	バネザガネ2-5	WASHER SPRING 2-5	
51	S55485001	2	アナボルトザクミ5X10	BOLT SOCKET (S/P WASHER)M5X10	
52	SB4525001	4	アナヒラ4X10	SET SCREW SOCKET (FT) M4X10	
53	021400106	4	1シュナット4	NUT 1 M4	

C7. 送り関係 (BAS-311HN-0□A) / Feed mechanism (BAS-311HN-0□A)

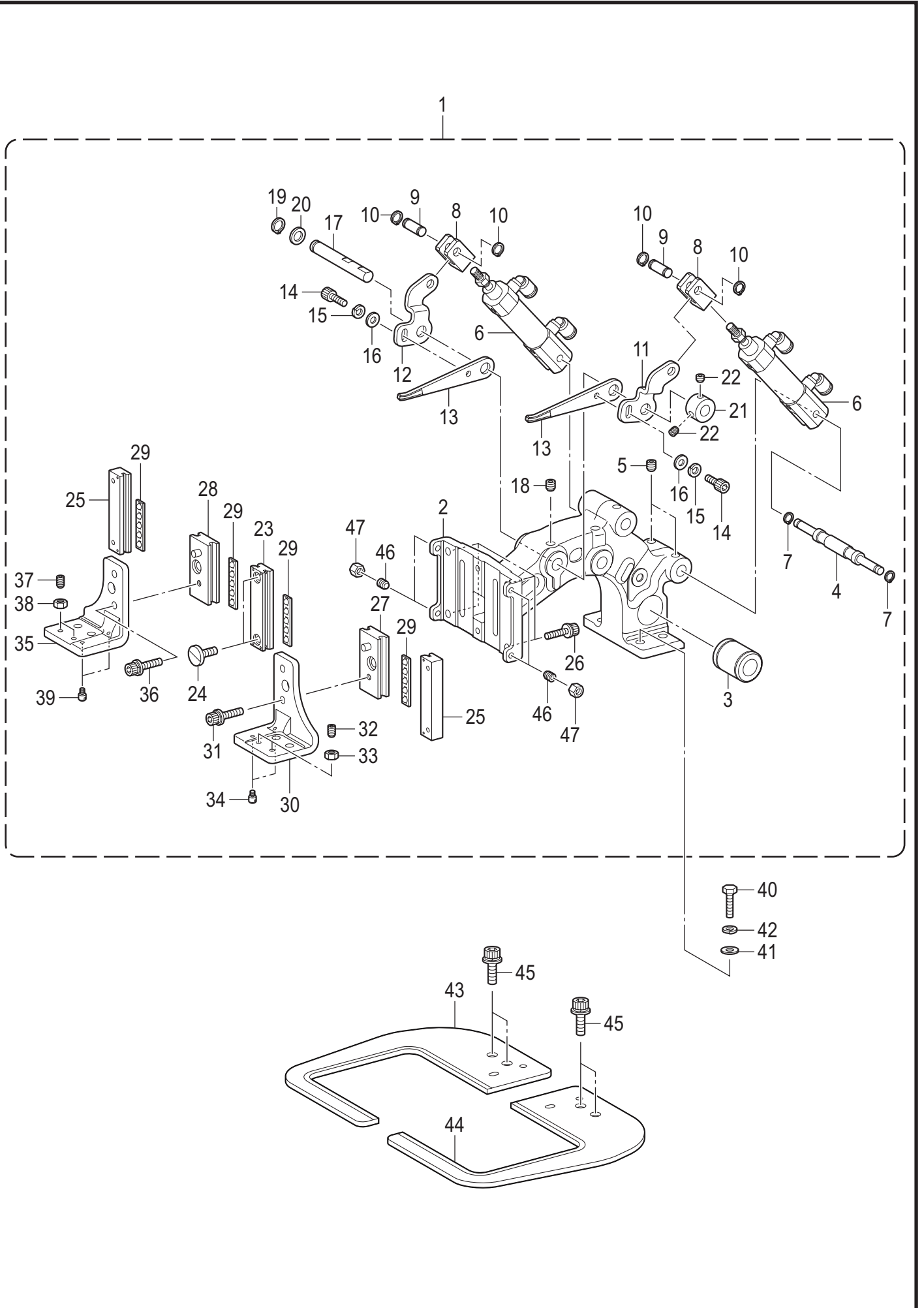

C7. 送り関係 (BAS-311HN-0[J]A) / Feed mechanism (BAS-311HN-0[J]A)

REF.NO	CODE	Q'TY	品名	NAME OF PARTS	RM
1	SB4454001	1	オサエウデ311Hエアークミ	WORK CLAMP ASSY 311H AIR	
2	SB4404001	1	オサエウデ	WORK CLAMP ARM	
3	S35183000	1	リニアブツシュ12	LINEAR BUSH, 12	
4	SA4717001	1	シリンダージク	CYLINDER SHAFT	
5	012060636	2	アナヒラ6X6	SET SCREW SOCKET (FT) M6X6	
6	SA4719001	2	エアシリンダRクミ	AIR CYLINDER ASSY	
7	048050142	2	トメワジクヨウC5	RETAINING RING EXTERNAL C5	
8	SA4720001	2	シリンダーツギテ	CYLINDER JOINT	
9	SA4721001	2	シリンダーツギテジク	CYLINDER JOINT SHAFT	
10	048060142	4	トメワジクヨウC6	RETAINING RING EXTERNAL C6	
11	SB4371001	1	オサエウデレバー-R エア-	WORK CLAMP LIFTER LEVER R AIR	
12	SB4370001	1	オサエウデレバー-L エア-	WORK CLAMP LIFTER LEVER L AIR	
13	SB4369001	2	オサエウデレバー エア-	WORK CLAMP LIFTER LEVER AIR	
14	018400836	2	アナボルト4X8	BOLT SOCKET M4X8	
15	028040246	2	バネザガネ2-4	WASHER SPRING 2-4	
16	100645004	2	ザガネ	WASHER	
17	SA4692001	1	オサエウデレバージク	WORK CLAMP LIFTER SHAFT	
18	012060636	1	アナヒラ6X6	SET SCREW SOCKET (FT) M6X6	
19	048080142	1	トメワジクヨウC8	RETAINING RING EXTERNAL C8	
20	110367001	1	ザガネ	WASHER, PLAIN SPECIAL 8	
21	SA3231001	1	セツトカラ-B	SET SCREW COLLAR,B	
22	012060536	2	アナヒラ6X5	SET SCREW, SOCKET (FT) M6X5	
23	SA4863001	1	オサエアシアンナイAクミ	WORK CLAMP GUIDE A ASSY	
24	S23849101	2	シメネジ4X16	SCREW M4X16	
25	SA4864001	2	オサエアシアンナイBクミ	WORK CLAMP GUIDE B ASSY	
26	S55482001	4	アナボルトザクミ4X14	BOLT SOCKET (S/P WASHER)M4X14	
27	SA4712001	1	オサエアシスライダRクミ	WORK CLAMP SLIDER ASSY R	
28	SA4714001	1	オサエアシスライダLクミ	WORK CLAMP SLIDER ASSY L	
29	SA4706101	4	オサエアシリテーナクミ	WORK CLAMP RETAINER ASSY	
30	SB4455001	1	オサエアシRクミ	WORK CLAMP ASSY R	
31	S55485001	1	アナボルトザクミ5X12	BOLT SOCKET (S/P WASHER)M5X12	
32	012501031	2	アナヒラ5X10	SET SCREW SOCKET (FT) M5X10	
33	021500216	2	2シュナット5	NUT 2 M5	
34	SA4709001	2	イチギメダンネジ	SHOULDER SCREW	
35	SB4456001	1	オサエアシLクミ	WORK CLAMP ASSY L	
36	S55485001	1	アナボルトザクミ5X12	BOLT SOCKET (S/P WASHER)M5X12	
37	012501031	2	アナヒラ5X10	SET SCREW SOCKET (FT) M5X10	
38	021500216	2	2シュナット5	NUT 2 M5	
39	SA4709001	2	イチギメダンネジ	SHOULDER SCREW	
40	017501616	4	ボルト5X16	BOLT M5X16	
41	SB3849001	4	ヒラザガネチュウ5	WASHER_PLAIN_M_5	
42	028050246	4	バネザガネ2-5	WASHER SPRING 2-5	
43	SB4460001	1	オサエイタ311Hクミ L	WORK CLAMP 311H L ASSY	
44	SB4461001	1	オサエイタ311Hクミ R	WORK CLAMP 311H R ASSY	
45	S55485001	4	アナボルトザクミ5X10	BOLT SOCKET (S/P WASHER)M5X10	
46	SB4525001	4	アナヒラ4X10	SET SCREW SOCKET (FT) M4X10	
47	021400106	4	1シュナット4	NUT 1 M4	

C8. 送り関係 (BAS-326H) / Feed mechanism (BAS-326H)

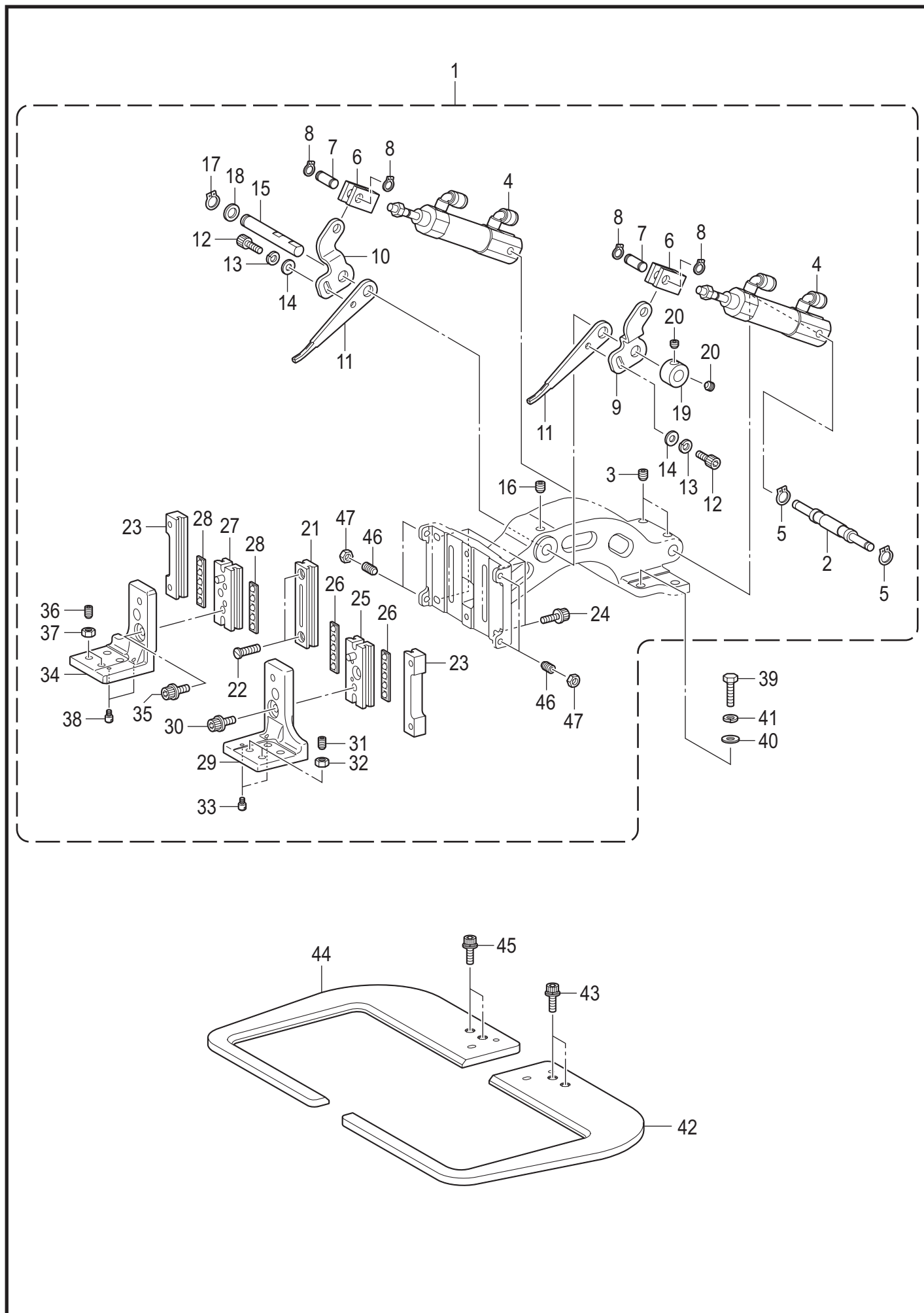

C8. 送り関係 (BAS-326H) / Feed mechanism (BAS-326H)

REF.NO	CODE	Q'TY	品名	NAME OF PARTS	RM
1	SB5938001	1	オサエウデUクミ	WORK CLAMP U ASSY	
2	SA4717001	1	シリンダ-ジク	CYLINDER SHAFT	
3	012060636	2	アナヒラ6X6	SET SCREW SOCKET (FT) M6X6	
4	SA4719001	2	エアシリンダRクミ	AIR CYLINDER ASSY	
5	048050142	2	トメワジクヨウC5	RETAINING RING EXTERNAL C5	
6	SA4720001	2	シリンダ-ツギテ	CYLINDER JOINT	
7	SA4721001	2	シリンダ-ツギテジク	CYLINDER JOINT SHAFT	
8	048060142	4	トメワジクヨウC6	RETAINING RING EXTERNAL C6	
9	SB4371101	1	オサエウデレバーR エアー	WORK CLAMP LIFTER LEVER R AIR	
10	SB4370101	1	オサエウデレバーL エアー	WORK CLAMP LIFTER LEVER L AIR	
11	SB4369001	2	オサエウデレバー エアー	WORK CLAMP LIFTER LEVER AIR	
12	018400836	2	アナボルト4X8	BOLT SOCKET M4X8	
13	028040246	2	バネザガネ2-4	WASHER SPRING 2-4	
14	100645004	2	ザガネ	WASHER	
15	SA4692001	1	オサエウデレバー-ジク	WORK CLAMP LIFTER SHAFT	
16	012060636	1	アナヒラ6X6	SET SCREW SOCKET (FT) M6X6	
17	048080142	1	トメワジクヨウC8	RETAINING RING EXTERNAL C8	
18	110367001	1	ザガネ	WASHER, PLAIN SPECIAL 8	
19	SA3231001	1	セツトカラ-B	SET SCREW COLLAR,B	
20	012060536	2	アナヒラ6X5	SET SCREW, SOCKET (FT) M6X5	
21	SA4863001	1	オサエアジアシアンナイAクミ	WORK CLAMP GUIDE A ASSY	
22	S23849101	2	シメネジ4X16	SCREW M4X16	
23	SA4864001	2	オサエアジアシアンナイBクミ	WORK CLAMP GUIDE B ASSY	
24	S55482001	4	アナボルトザクミ4X14	BOLT SOCKET (S/P WASHER)M4X14	
25	SA4712001	1	オサエアシスライダRクミ	WORK CLAMP SLIDER ASSY R	
26	SA4706101	2	オサエアシリテ-ナクミ	WORK CLAMP RETAINER ASSY	
27	SA4714001	1	オサエアシスライダLクミ	WORK CLAMP SLIDER ASSY L	
28	SA4706101	2	オサエアシリテ-ナクミ	WORK CLAMP RETAINER ASSY	
29	SB4455001	1	オサエアシRクミ	WORK CLAMP ASSY R	
30	S55485001	1	アナボルトザクミ5X12	BOLT SOCKET (S/P WASHER)M5X12	
31	012501031	2	アナヒラ5X10	SET SCREW SOCKET (FT) M5X10	
32	021500216	2	2シュナット5	NUT 2 M5	
33	SA4709001	2	イチギメダンネジ	SHOULDER SCREW	
34	SB4456001	1	オサエアシLクミ	WORK CLAMP ASSY L	
35	S55485001	1	アナボルトザクミ5X12	BOLT SOCKET (S/P WASHER)M5X12	
36	012501031	2	アナヒラ5X10	SET SCREW SOCKET (FT) M5X10	
37	021500216	2	2シュナット5	NUT 2 M5	
38	SA4709001	2	イチギメダンネジ	SHOULDER SCREW	
39	SB4810001	4	ボルトM5X16	BOLT M5X16	
40	SB3849001	4	ヒラザガネチュウ5	WASHER_PLAIN_M_5	
41	028050246	4	バネザガネ2-5	WASHER SPRING 2-5	
42	SA4870201	1	オサエイタ326Rクミ	WORK CLAMP 326R ASSY	
43	S55485001	2	アナボルトザクミ5X12	BOLT SOCKET (S/P WASHER)M5X12	
44	SA4871201	1	オサエイタ326Lクミ	WORK CLAMP 326L ASSY	
45	S55485001	2	アナボルトザクミ5X12	BOLT SOCKET (S/P WASHER)M5X12	
46	SB4525001	4	アナヒラ4X10	SET SCREW SOCKET (FT) M4X10	
47	021400106	4	1シュナット4	NUT 1 M4	

< 送り板: 下締めタイプ
/ Feed plate: For bottom-tightening type >

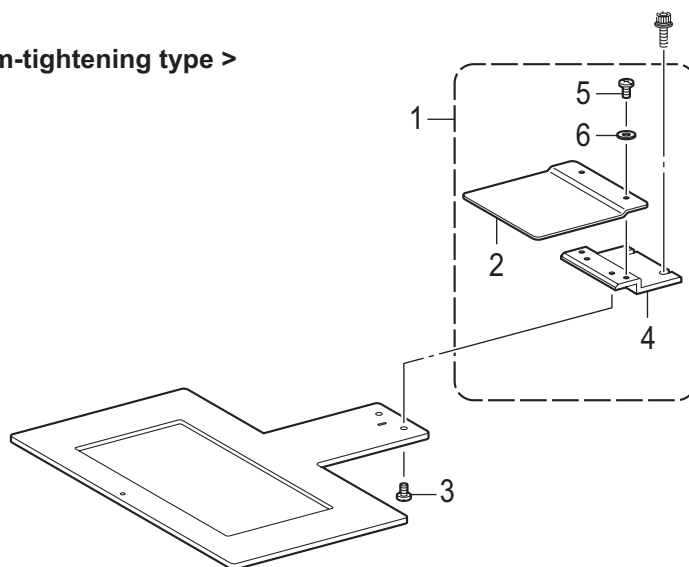

< 一体タイプ / For single type >

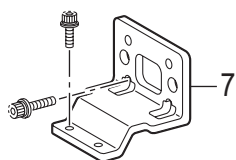

< 左右分離タイプ / For separate type >

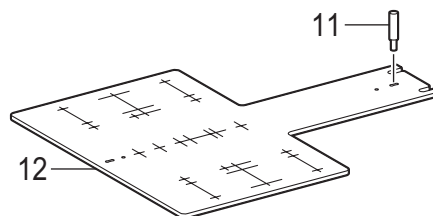
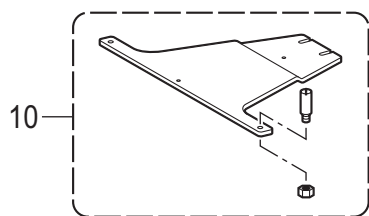
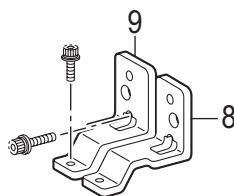

C9. 送り関係（オプション部品） / Feed mechanism (Option parts)

REF.NO	CODE	Q'TY	品名	NAME OF PARTS	RM
1	SA7141001	1	<送り板:下締めタイプ> 311オクリイタヘンカンBクミ	<Feed plate: For bottom-tightening type> 311 FEED PLATE CHANGE B SET	
2	SA6604001	1	オクリイタカバー-311-1	FEED PLATE COVER 311-1	
3	S23418001	2	シメネジ4X5	SCREW M4X5	
4	SA6603001	1	オクリイタスペーサ	FEED PLATE SPACER	
5	S23418001	2	シメネジ4X5	SCREW M4X5	
6	025040236	2	ヒラザガネチュウ4	WASHER PLAIN M 4	
7	SA6595001	1	<一体タイプ> オサエアシ311Fタイプ	<For single type> WORK CLAMP 311F TYPE	
8	SA6599001	1	<左右分離タイプ> オサエアシ311FRタイプ	<For separate type> WORK CLAMP 311F R TYPE	
9	SA6600001	1	オサエアシ311FLタイプ	WORK CLAMP 311F L TYPE	
10	SA7385001	1	<カセットオサエ> カセットシジイタ311Gクミ	<Cassette clamp> CASSETTE BOARD 311G ASSY	
11	SA5415001	2	ゲンテンキジュンピン	ORIGIN STANDARD PIN	
12	SA6640101	1	ゲンテンキジュンイタ	ORIGIN STANDARD PLATE	

D1. 押え上げ関係 / Work clamp lifter mechanism

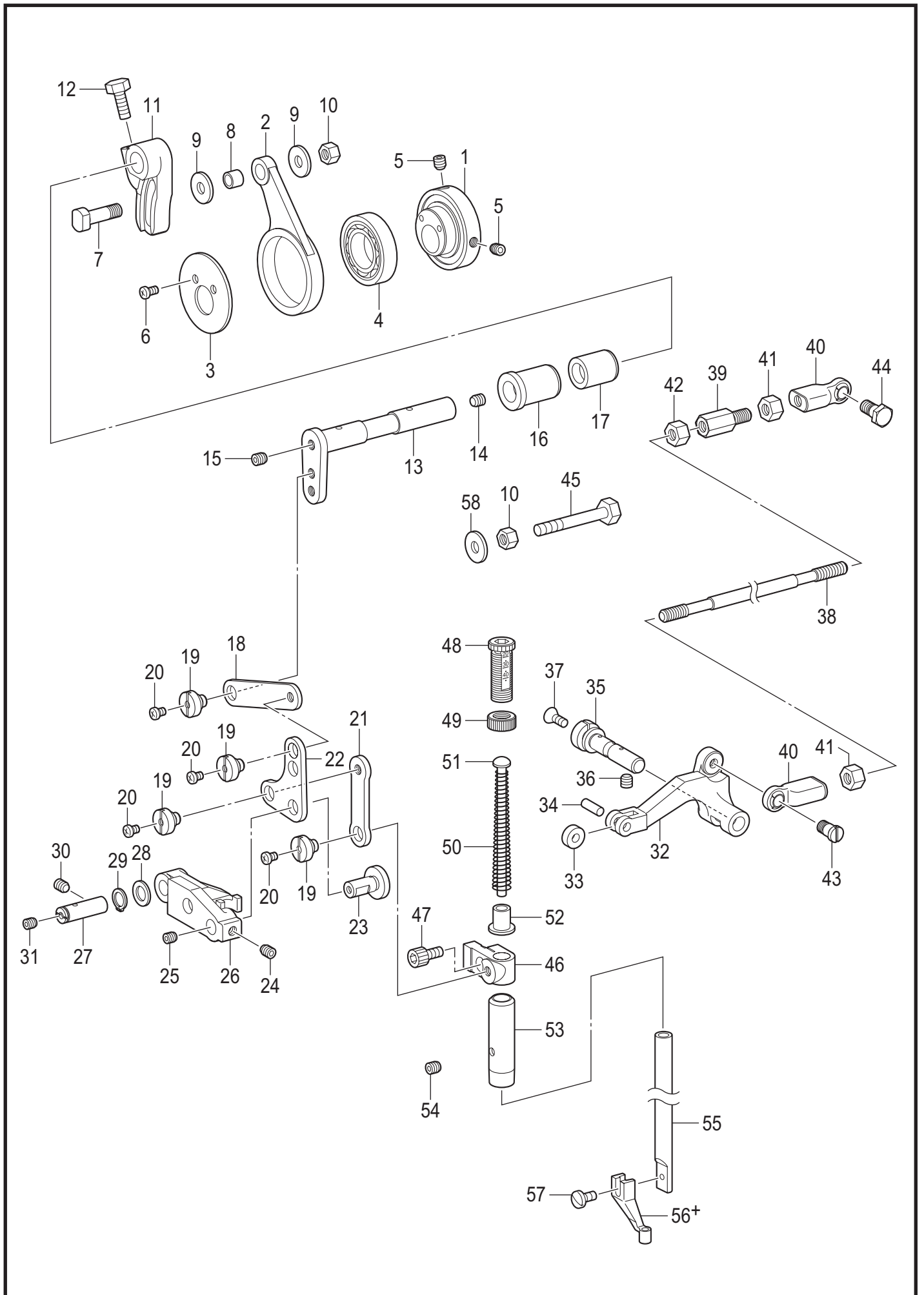

D1. 押え上げ関係 / Work clamp lifter mechanism

REF.NO	CODE	Q'TY	品名	NAME OF PARTS	RM
1	SA4759001	1	カンケツオサエカム	STEPPING CLAMP CAM	
2	SA4760001	1	カンケツオサエレンカン	STEPPING CLAMP CON.ROD	
3	SA4763001	1	カンケツオサエカムザガネ	WASHER STEPPING CLAMP CAM	
4	SA7704001	1	タマジクウケ6805VV	BALL BEARING 6805VV	
5	S23651001	2	アナヒラ6X6ホソメ	SET SCREW SOCKET (FT) M6X6	
6	062400616	2	ナベコ4X6	SCREW PAN M4X6	
7	SA4761001	1	カンケツオサエウデコロジク	ROLLER SHAFT STEPPING CLAMP	
8	SA4762001	1	カンケツオサエウデコロ	ROLLER STEPING CLAMP	
9	SA4302001	2	ザガネ	WASHER	
10	021060106	2	1シュナット6	NUT 1 M6	
11	SA4764001	1	カンケツオサエウデR	STEPPING CLAMP ARM R	
12	017061213	1	ボルト6X12	BOLT M6X12	
13	SA4765001	1	カンケツオサエウデF	STEPPING CLAMP ARM F	
14	012060636	1	アナヒラ6X6	SET SCREW SOCKET (FT) M6X6	
15	S23651001	1	アナヒラ6X6ホソメ	SET SCREW SOCKET (FT) M6X6	
16	SA4766001	1	カンケツオサエウデメタルF	BUSH STEPPING CLAMP F	
17	SA4767001	1	カンケツオサエウデメタルR	BUSH STEPPING CLAMP R	
18	SA4768001	1	カンケツレンカンA	STEPPING CLAMP LINK A	
19	SA4769101	4	ダンネジ6	SHOULDER SCREW 6	
20	062300416	4	ナベコ3X4	SCREW PAN M3X4	
21	SA4770001	1	カンケツレンカンB	STEPPING CLAMP LINK B	
22	SA4772001	1	カンケツリンク	STEPPING CLAMP LINK	
23	SA4773001	1	カンケツリンクジク	SHAFT STEPPING CLAMP LINK	
24	012060636	1	アナヒラ6X6	SET SCREW SOCKET (FT) M6X6	
25	012400436	1	アナヒラ4X4	SET SCREW SOCKET (FT) M4X4	
26	SA4777001	1	カンケツアゲリンク	STEPPING CLAMP LIFTER LINK	
27	SA4771001	1	カンケツアゲリンクジク	SHAFT STEPPING CLAMP LIFT LINK	
28	SA2161001	1	ザガネ	WASHER	
29	048080142	1	トメワジクヨウC8	RETAINING RING EXTERNAL C8	
30	012060636	1	アナヒラ6X6	SET SCREW SOCKET (FT) M6X6	
31	012400436	1	アナヒラ4X4	SET SCREW SOCKET (FT) M4X4	
32	SA4779101	1	カンケツアゲレバー	STEPPING CLAMP LIFTER	
33	SA4781001	1	カンケツアゲレバーコロ	ROLLER STEPPING CLAMP LIFTER	
34	141362001	1	エントウコロ	ROLLER	
35	SA4780001	1	カンケツアゲレバージク	SHAFT STEPPING CLAMP LIFTER	
36	012060636	1	アナヒラ6X6	SET SCREW SOCKET (FT) M6X6	
37	S25310101	1	サラネジ4	SCREW, FLAT M4	
38	SA4775101	1	カンケツアゲロッド	STEPPING CLAMP LIFTER ROD	
39	SA4853001	1	カンケツアゲロッドツギテ	JOINT STEPPING CLAMP LIFTER	
40	SA8684001	2	タマツギテクミ	ROUND JOINT ASSY	
41	021060306	2	3シュナット6	NUT 3 M6	
42	SA3227001	1	ナット6ホソメ	NUT(FT),M6	
43	SA8689001	1	シメネジ6X12	SCREW M6X12	
44	017061612	1	ボルト6X16	BOLT M6X16	
45	017065002	1	ボルト6X50	BOLT M6X50	
46	SA4778001	1	オサエボウダキ	PRESSER BAR CLAMP	
47	018400836	1	アナボルト4X8	BOLT SOCKET M4X8	
48	SA1174002	1	オサエチヨウセツネジM14	PESSEER ADJUSTING SCREW M14	
49	SA1175002	1	チヨウセツネジナットM14	ADJUST SCREW NUT	
50	SA5300001	1	オサエバネ	PRESSER BAR SPRING	
51	S10112101	1	オサエバネアンナイ	PRESSER BAR SPRING GUIDE	
52	SA5301001	1	オサエバネカラ	COLLAR PRESSER BAR SPRING	
53	SA2195001	1	オサエボウメタル	PRESSER BAR BUSH	
54	012060536	1	アナヒラ6X5	SET SCREW, SOCKET (FT) M6X5	
55	111466121	1	オサエボウ	PRESSER BAR	
56+	P.74	1	オサエアシ	PRESSER FOOT	
57	S13399001	1	シメネジ3.57X12	SCREW, SM3.57X12	
58	151439102	1	ザガネ	WASHER	

D2. 押え上げ関係 (BAS-311HN-0□S) / Work clamp lifter mechanism (BAS-311HN-0□S)

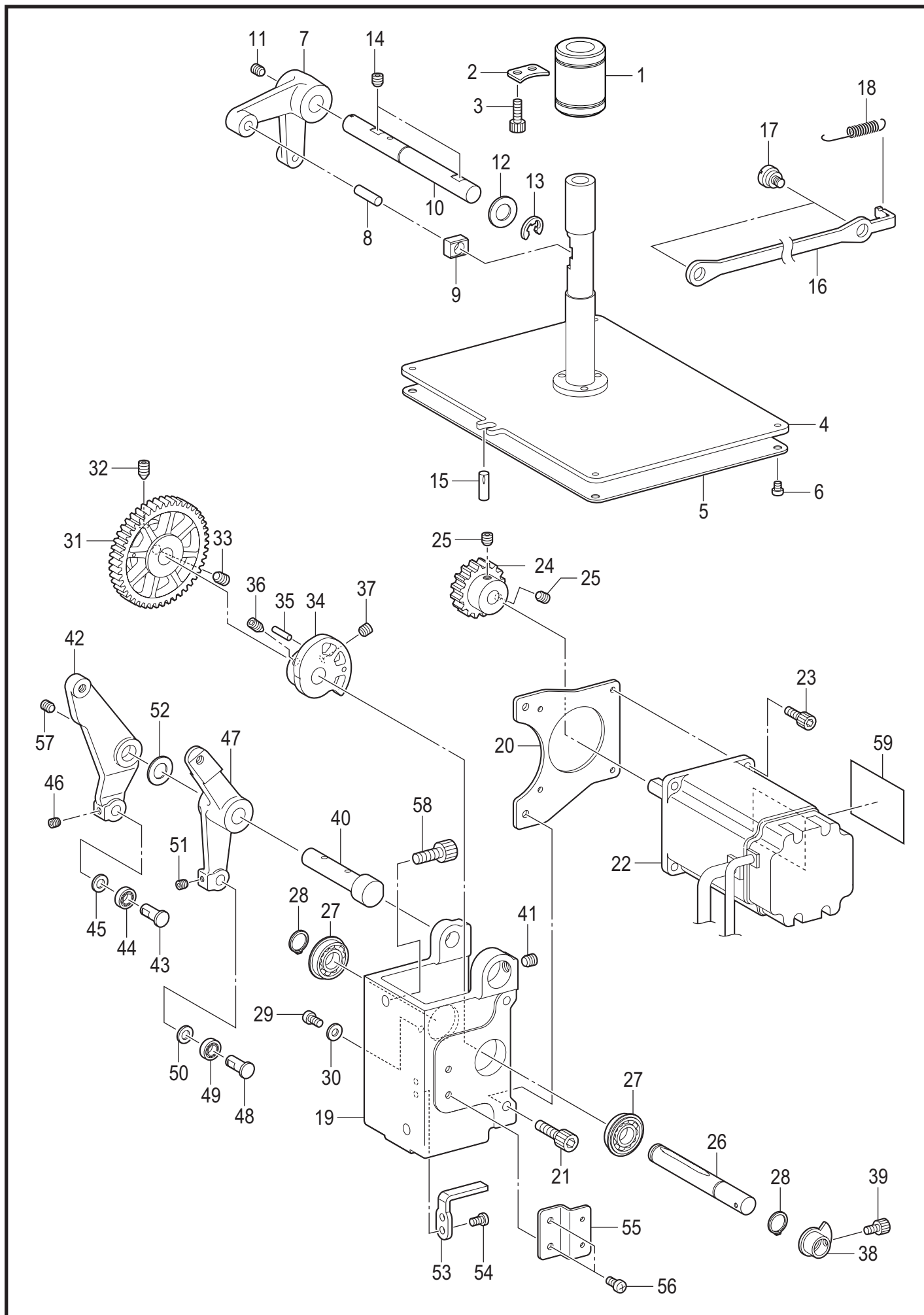

D2. 押え上げ関係 (BAS-311HN-0[S]) / Work clamp lifter mechanism (BAS-311HN-0[S])

REF.NO	CODE	Q'TY	品名	NAME OF PARTS	RM
1	SA5593001	1	ボールブツシュ	LINEAR BUSH 16	
2	SB4381001	1	リニアブシュトメイタ	LINEAR BUSH SETTING PLATE	
3	018400836	2	アナボルト4X8	BOLT SOCKET M4X8	
4	SB4424001	1	オサエアゲイタクミ	WORK CLAMP LIFTER PLATE ASSY	
5	SB4423001	1	シートE 150X100	SEAT E 150X100	
6	062400416	4	ナベコ4X4	SCREW, PAN M4X4	
7	SA4736001	1	オサエアゲレバー	WORK CLAMP LIFTER LEVER	
8	152744001	1	ヨコオクリカクコマピン	PIN	
9	102630021	1	ハリボウアンナイカクコマ	NEEDLE BAR GUIDE SLIDE BLOCK	
10	SA4737001	1	オサエアゲレバー-ジクB	WORK CLAMP LEVER SHAFT B	
11	012060636	1	アナヒラ6X6	SET SCREW SOCKET (FT) M6X6	
12	S20356001	1	ヒラザガネ10	WASHER, PLAIN 10	
13	048080342	1	トメワE8	RETAINING RING E8	
14	012060636	2	アナヒラ6X6	SET SCREW SOCKET (FT) M6X6	
15	118208001	1	ミゾツキピン	DOWEL PIN	
16	SA4738001	1	オサエアゲリンク	WORK CLAMP LIFTER LINK	
17	SB0705101	2	オサエアゲリンクダンネジ	LINK SHOULDER SCREW	
18	SA4739001	1	オサエアゲバネ	WORK CLAMP SPRING	
19	SA4741301	1	モーターブラケット	MOTOR BRACKET	
20	SB4382001	1	オサエアゲモータイタ	WORK CLAMP MOTOR PLATE	
21	018501036	2	アナボルト5X10	BOLT SOCKET M5X10	
22	SB4277201	1	パルスモータPクミ	PULSE MOTOR ASSY P	
23	018401036	4	アナボルト4X10	BOLT SOCKET M4X10	
24	SA4743001	1	オサエアゲクドウギヤ	WORK CLAMP DRIVING GEAR	
25	012060636	2	アナヒラ6X6	SET SCREW SOCKET (FT) M6X6	
26	SA4744001	1	オサエアゲシテンジク	WORK CLAMP FULCRUM SHAFT	
27	SA4647001	2	タマジクウケ6900ZZNR	BALL BEARING 6900ZZNR	
28	048100142	2	トメワジクヨウC10	RETAINING RING EXTERNAL C10	
29	062400616	1	ナベコ4X6	SCREW PAN M4X6	
30	SB3848001	1	ヒラザガネチュウ4	WASHER PLAIN M 4	
31	SA4745001	1	オサエアゲカムギヤ	WORK CLAMP CAM GEAR	
32	016061031	1	アナトガリ6X10	SET SCREW SOCKET (CN) M6X10	
33	012060636	1	アナヒラ6X6	SET SCREW SOCKET (FT) M6X6	
34	SA4746001	1	オサエアゲカム	WORK CLAMP CAM	
35	S35079000	1	ニードルローラ3X11.8	NEEDLE ROLLER, 3X11.8	
36	016061031	1	アナトガリ6X10	SET SCREW SOCKET (CN) M6X10	
37	012060636	1	アナヒラ6X6	SET SCREW SOCKET (FT) M6X6	
38	SA4747001	1	オサエゲンテンドグ	WORK CLAMP H-POSITION DOG	
39	018400636	1	アナボルト4X6	BOLT SOCKET M4X6	
40	SA4748101	1	オサエアゲレバー-ジク	WORK CLAMP LEVER SHAFT	
41	012060636	1	アナヒラ6X6	SET SCREW SOCKET (FT) M6X6	
42	SA6210001	1	カンケツクドウレバー	STEPPING W-CLAMP DRIVING LEVER	
43	SA3441101	1	オサエアゲコロジク	W-CLAMP LIFTER ROLLER SHAFT	
44	070696800	1	Rタマジクウケ696ZZ	BALL BEARING RADIAL 696ZZ	
45	109763022	1	ザガネ	WASHER	
46	012500536	1	アナヒラ5X5	SET SCREW SOCKET (FT) M5X5	
47	SA4750001	1	オサエアゲクドウレバー	WORK CLAMP DRIVING SHAFT	
48	SA3441101	1	オサエアゲコロジク	W-CLAMP LIFTER ROLLER SHAFT	
49	070696800	1	Rタマジクウケ696ZZ	BALL BEARING RADIAL 696ZZ	
50	109763022	1	ザガネ	WASHER	
51	012500536	1	アナヒラ5X5	SET SCREW SOCKET (FT) M5X5	
52	S20356001	1	ヒラザガネ10	WASHER, PLAIN 10	
53	SA4752001	1	オサエアゲカムストッパ	WORK CLAMP CAM STOPPER	
54	062400616	2	ナベコ4X6	SCREW PAN M4X6	
55	SA4753001	1	オサエアゲセンサーイタ	WORK CLAMP SENSOR PLATE	
56	062400616	2	ナベコ4X6	SCREW PAN M4X6	
57	012060636	1	アナヒラ6X6	SET SCREW SOCKET (FT) M6X6	
58	018061236	2	アナボルト6X12	BOLT SOCKET M6X12	
59	SA4224001	1	マークチュウイ30X40	MARK ATTENTION 30X40	

D3. 押え上げ関係 (-0□A) / Work clamp lifter mechanism (-0□A)

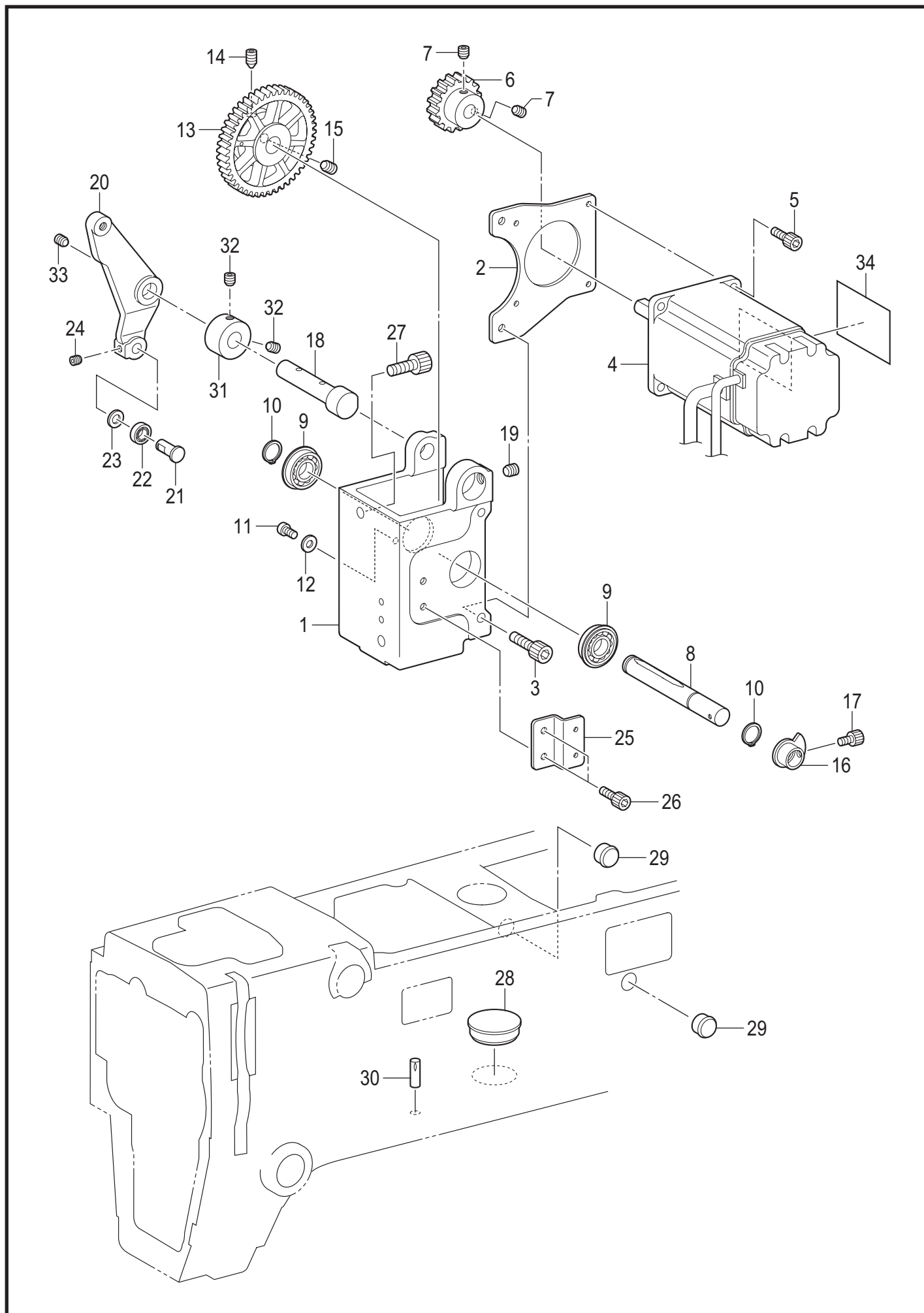

D3. 押え上げ関係 (-0[A]) / Work clamp lifter mechanism (-0[A])

REF.NO	CODE	Q'TY	品名	NAME OF PARTS	RM
1	SA4741301	1	モーターブラケット	MOTOR BRACKET	
2	SB4382001	1	オサエアゲモータイタ	WORK CLAMP MOTOR PLATE	
3	018501036	2	アナボルト5X10	BOLT SOCKET M5X10	
4	SB4277001	1	パルスモータPクミ	PULSE MOTOR ASSY P	
5	018401036	4	アナボルト4X10	BOLT SOCKET M4X10	
6	SA4743001	1	オサエアゲクドウギヤ	WORK CLAMP DRIVING GEAR	
7	012060636	2	アナヒラ6X6	SET SCREW SOCKET (FT) M6X6	
8	SA4744001	1	オサエアゲシテンジク	WORK CLAMP FULCRUM SHAFT	
9	SA4647001	2	タマジクウケ6900ZZNR	BALL BEARING 6900ZZNR	
10	048100142	2	トメワジクヨウC10	RETAINING RING EXTERNAL C10	
11	062400616	1	ナベコ4X6	SCREW PAN M4X6	
12	SB3848001	1	ヒラザガネチュウ4	WASHER_PLAIN_M_4	
13	SA4745001	1	オサエアゲカムギヤ	WORK CLAMP CAM GEAR	
14	016061031	1	アナトガリ6X10	SET SCREW SOCKET (CN) M6X10	
15	012060636	1	アナヒラ6X6	SET SCREW SOCKET (FT) M6X6	
16	SA4747001	1	オサエゲンテンドグ	WORK CLAMP H-POSITION DOG	
17	018400636	1	アナボルト4X6	BOLT SOCKET M4X6	
18	SA4748101	1	オサエアゲレバ-ジク	WORK CLAMP LEVER SHAFT	
19	012060636	1	アナヒラ6X6	SET SCREW SOCKET (FT) M6X6	
20	SA6210001	1	カンケツクドウレバ-	STEPPING W-CLAMP DRIVING LEVER	
21	SA3441101	1	オサエアゲコロジク	W-CLAMP LIFTER ROLLER SHAFT	
22	070696800	1	Rタマジクウケ696ZZ	BALL BEARING RADIAL 696ZZ	
23	109763022	1	ザガネ	WASHER	
24	012500536	1	アナヒラ5X5	SET SCREW SOCKET (FT) M5X5	
25	SA4753001	1	オサエアゲセンサーイタ	WORK CLAMP SENSOR PLATE	
26	018400836	2	アナボルト4X8	BOLT SOCKET M4X8	
27	018061236	2	アナボルト6X12	BOLT SOCKET M6X12	
28	159163000	1	ゴムセン29	RUBBER CAP 29	
29	104821001	2	ゴムセン10.5	RUBBER CAP, 10.5	
30	118550001	1	ミゾツキピン	PIN DOWEL	
31	SA4757101	1	セツトカラ-	SET SCREW COLLAR	
32	012060636	2	アナヒラ6X6	SET SCREW SOCKET (FT) M6X6	
33	012060636	1	アナヒラ6X6	SET SCREW SOCKET (FT) M6X6	
34	SA4224001	1	マークチュウイ30X40	MARK ATTENTION 30X40	

E. 下軸関係 / Lower shaft mechanism

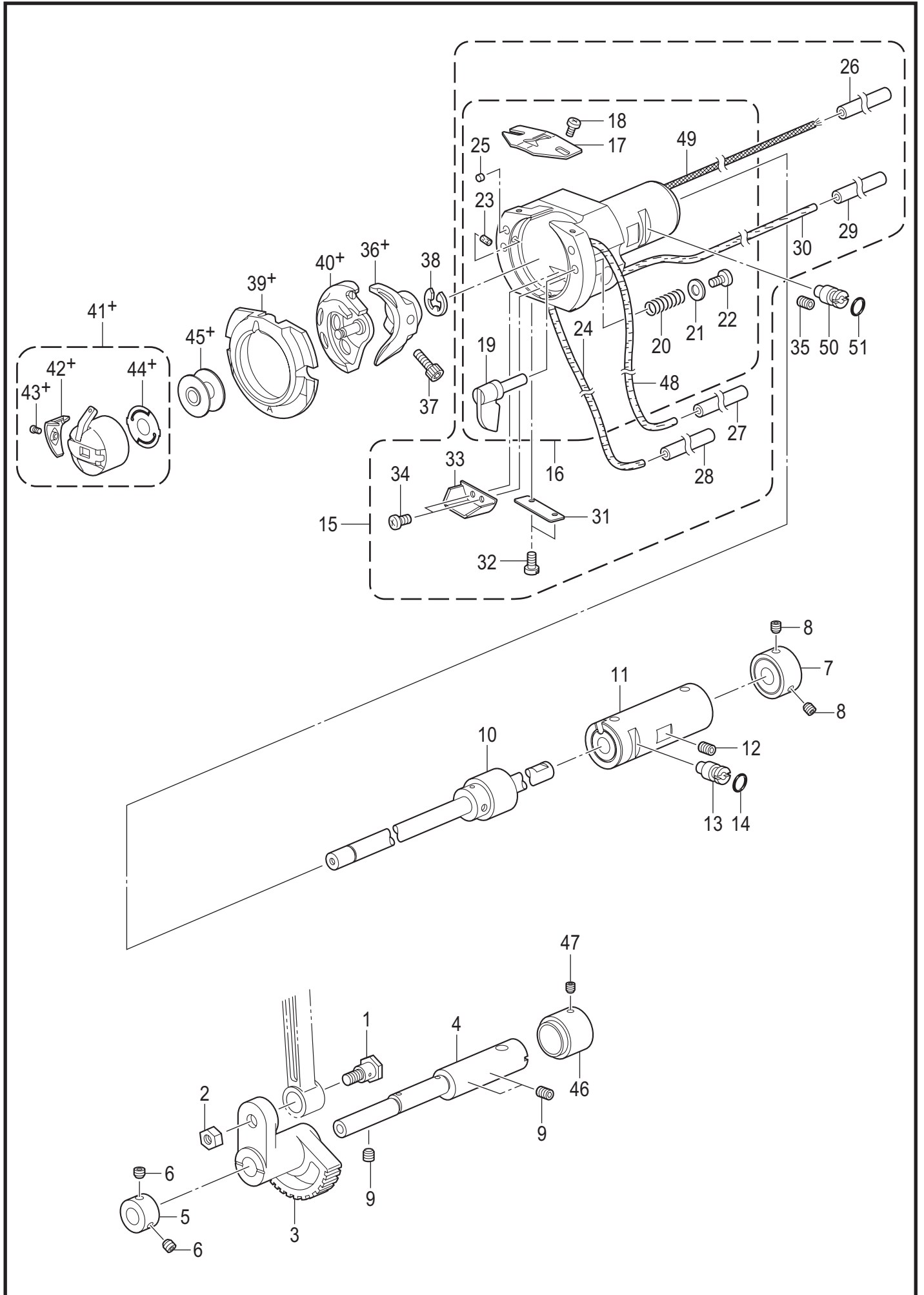

E. 下軸関係 / Lower shaft mechanism

REF.NO	CODE	Q'TY	品名	NAME OF PARTS	RM
1	SA3226001	1	クランクロッドダンネジ	SHOULDER SCREW	
2	SA3227001	1	ナツト6ホソメ	NUT(FT),M6	
3	SA3228101	1	ヨウドウギヤ	ROCK GEAR	
4	SA4782001	1	ヨウドウギヤジク	ROCK GEAR SHAFT	
5	SA3231001	1	セツトカラ-B	SET SCREW COLLAR,B	
6	012060536	2	アナヒラ6X5	SET SCREW, SOCKET (FT) M6X5	
7	SA3233101	1	セツトカラ-	SET SCREW COLLAR	
8	S23651001	2	アナヒラ6X6ホソメ	SET SCREW SOCKET (FT) M6X6	
9	012060636	3	アナヒラ6X6	SET SCREW SOCKET (FT) M6X6	
10	SA4783101	1	シタジククミ	LOWER SHAFT ASSY	
11	SB4187101	1	シタジクメタル	LOWER SHAFT BUSH	
12	012060636	1	アナヒラ6X6	SET SCREW SOCKET (FT) M6X6	
13	SA3238401	1	カマチヨウセツジク	ADJUSTING STUD	
14	081003670	1	OリングPW3	O RING PW3	
15	SB4508101	1	オオカマタイHソウクミ	SHUTTLE RACE BASE SET H	
16	SB4509001	1	オオカマタイHクミ	SHUTTLE RACE BASE ASSY H	
17	S02429201	1	カマイトアンナイ	SHUTTLE RACE THREAD GUIDE	
18	SA4199001	2	シメネジ3X4	SCREW M3X4	
19	SA3241001	2	オオカマトリツケツメ	S-RACE BASE SETTING CLAW	
20	152684101	2	オオカマトリツケバネ	COMPRESSION SPRING	
21	402887001	2	ザガネ3.2	WASHER, 3.2	
22	062300616	2	ナベコ3X6	SCREW PAN M3X6	
23	SA9396001	2	フェルト	FELT	
24	S59886001	1	フェルト	FELT, L=360	
25	SA9397001	2	ゴムセン5.5	RUBBER CAP 5.5	
26	SA9793001	1	ビニルチューブ	VINYL TUBE L=160	
27	S50557000	1	ビニルチューブ	OIL TUBE	
28	SB3511001	1	ビニルチューブ	VINYL TUBE	
29	SB4392001	1	ビニルチューブ	OIL TUBE L=380	
30	SB4464101	1	フェルトクミ	FELT ASSY	
31	SA3242001	1	フェルトササエ	FELT HOLDER	
32	SA9191001	2	シメネジM3X5.5	SCREW M3X5.5	
33	SA3274101	1	フェルトオサエ	FELT HOLDER	
34	S47307001	2	シメネジ3X4	SCREW, M3X4	
35	012060636	1	アナヒラ6X6	SET SCREW SOCKET (FT) M6X6	
36+	P.73	1	ドライバー	DRIVER	
37	018501232	1	アナボルト5X12	BOLT SOCKET M5X12	
38	048070342	1	トメワE7	RETAINING RING E7	
39+	P.73	1	オオカマ	SHUTTLE RACE BASE	
40+	P.73	1	カマハコクミ	SHUTTLE HOOK ASSY W/BOX	
41+	P.73	1	ボビンケースクミ	BOBBIN CASE ASSY	
42+	P.73	1	ケースチヨウシバネ	TENSION SPRING	
43+	P.73	1	ボビンケースバネネジ	BOBBIN CASE SPRING SCREW	
44+	P.73	1	クウテンボウシバネ	ANTI-SPIN SPRING	
45+	P.73	1	ボビン	BOBBIN	
46	SA3283101	1	セツトカラ-R	SET SCREW COLLAR,R	
47	012500536	1	アナヒラ5X5	SET SCREW SOCKET (FT) M5X5	
48	SA8707001	1	フェルト	FELT	
49	108802001	1	クミヒモ4X4	WICK, 4X4 L=250	
50	SA3238401	1	カマチヨウセツジク	ADJUSTING STUD	
51	081003670	1	OリングPW3	O RING PW3	

F. 給油潤滑關係 / Lubrication

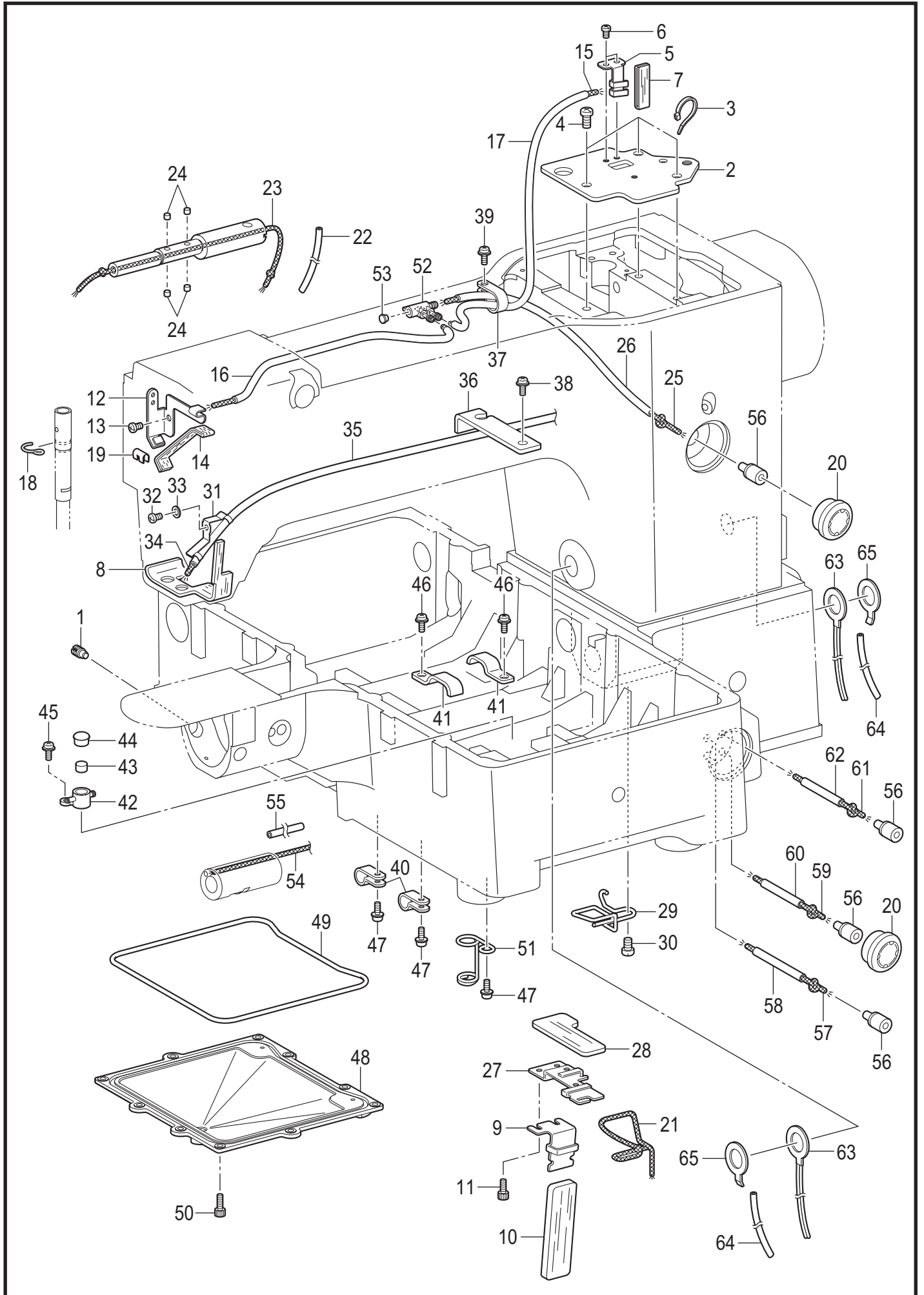

BAS-311HN/326H-350

F. 給油潤滑関係 / Lubrication

REF.NO	CODE	Q'TY	品名	NAME OF PARTS	RM
1	SA3244001	1	トメネジ	SET SCREW	
2	SA4785101	1	クランクカバー	CRANK COVER	
3	SB4155001	1	バンド	BAND	
4	062061016	3	ナベコ6X10	SCREW PAN M6X10	
5	SA4787001	1	クランクキユウユイタ	CRANK WICK PLATE	
6	062400616	2	ナベコ4X6	SCREW PAN M4X6	
7	SA5294001	1	ヒラクミヒモ	FLAT WICK L=90	
8	SA4786101	1	スイアゲフェルト	FELT	
9	SA3503201	1	シタジクキユウユササエ	LOWER SHAFT WICK SUPPORT	
10	SA3504201	1	シタジクギヤフェルト	LOWER SHAFT GEAR FELT	
11	018400636	2	アナボルト4X6	BOLT SOCKET M4X6	
12	SA4788001	1	テンビンキユウユササエ	WICK SUPPORT	
13	062400616	1	ナベコ4X6	SCREW PAN M4X6	
14	SA6593001	1	ヒラクミヒモ	FLAT WICK L=180	
15	SA6580001	1	クミヒモ	WICK L=780	
16	S07459100	1	ビニルチューブ	OIL TUBE L=240	
17	SA6576001	1	ビニルチューブ	OIL TUBE L=210	
18	SA6087001	1	ハリボウヒモササエ	WICK SUPPORT	
19	104567101	1	クミヒモササエ	WICK SUPPORT	
20	S49992000	2	オイルポットマド	OIL GAUGE WINDOW	
21	SA4025001	1	クミヒモ 4×4 L=180	WICK, 4×4 L=180	
22	SA2864001	1	ビニールチューブ	OIL TUBE L=193	
23	SB4524001	1	クミヒモ6X6	WICK 6X6 L=380	
24	S09043000	4	フェルト	FELT	
25	S49982000	1	クミヒモ4X4	WICK, 4X4 L=400	
26	S48189000	1	オイルチューブ	OIL TUBE L=280	
27	SA3246001	1	ギヤキユウユササエ	GEAR WICK SUPPORT	
28	SA3280001	1	ギヤフェルト	GEAR FELT	
29	SA4789101	1	シタジクキユウユササエB	LOWER SHAFT WICK SUPPORT B	
30	062060816	1	ナベコ6X8	SCREW PAN M6X8	
31	145547021	1	チューブホルダ	TUBE HOLDER	
32	062400616	1	ナベコ4X6	SCREW PAN M4X6	
33	026040136	1	ヒラザガネコガタ	WASHER PLAIN S 4	
34	S49957000	1	クミヒモ4X4	WICK, 4X4 L=700	
35	SA4791101	1	ビニルチューブ	OIL TUBE L=620	
36	SB6613001	1	コードホルダ	CORD HOLDER	
37	525567000	1	コードホルダ#8	CORD HOLDER #8	
38	0A5401006	1	+ナベザクミ4X10DB	SCREW PAN (S/P WASHER) M4X10	
39	0A5401006	1	+ナベザクミ4X10DB	SCREW PAN (S/P WASHER) M4X10	
40	525664000	2	コードホルダ#6	CORD HOLDER #6	
41	SA1394101	2	コードオサエU3	CORD HOLDER U3	
42	SB4468001	3	ターミナル	TERMINAL	
43	S38266000	3	カマジクフェルト	ROTARY HOOK SHAFT FELT	
44	SA2929001	3	ゴムセン12.5	RUBBER CAP, 12.5	
45	0A5401006	3	+ナベザクミ4X10DB	SCREW PAN (S/P WASHER) M4X10	
46	0A5401006	2	+ナベザクミ4X10DB	SCREW PAN (S/P WASHER) M4X10	
47	0A5401006	3	+ナベザクミ4X10DB	SCREW PAN (S/P WASHER) M4X10	
48	SB4387001	1	オイルカバー	OIL COVER	
49	SB4388001	1	オイルカバーパッキン	OIL COVER PACKING	
50	018401036	10	アナボルト4X10	BOLT SOCKET M4X10	
51	S50359001	1	チューブササエD	TUBE SUPPORT, D	
52	S38265000	1	ターミナルL	TERMINAL, L	
53	142274101	1	ゴムセン4.2	RUBBER CAP, 4.2	
54	S59886001	1	フェルト	FELT, L=360	
55	SA9793001	1	ビニルチューブ	VINYL TUBE L=160	
56	SA5339101	5	オイルクチパイプ	OIL FEEDING PIPE	
57	SB4570001	2	フェルト	FELT L=230	
58	SB4037001	2	ビニルチューブ	VINYL TUBE	
59	S08003000	1	クミヒモ 4X4	WICK 4X4	
60	SA6576001	1	ビニルチューブ	OIL TUBE L=210	
61	SB4736001	1	クミヒモ3X3(145)	WICK 3X3 L=145	

F. 給油潤滑關係 / Lubrication

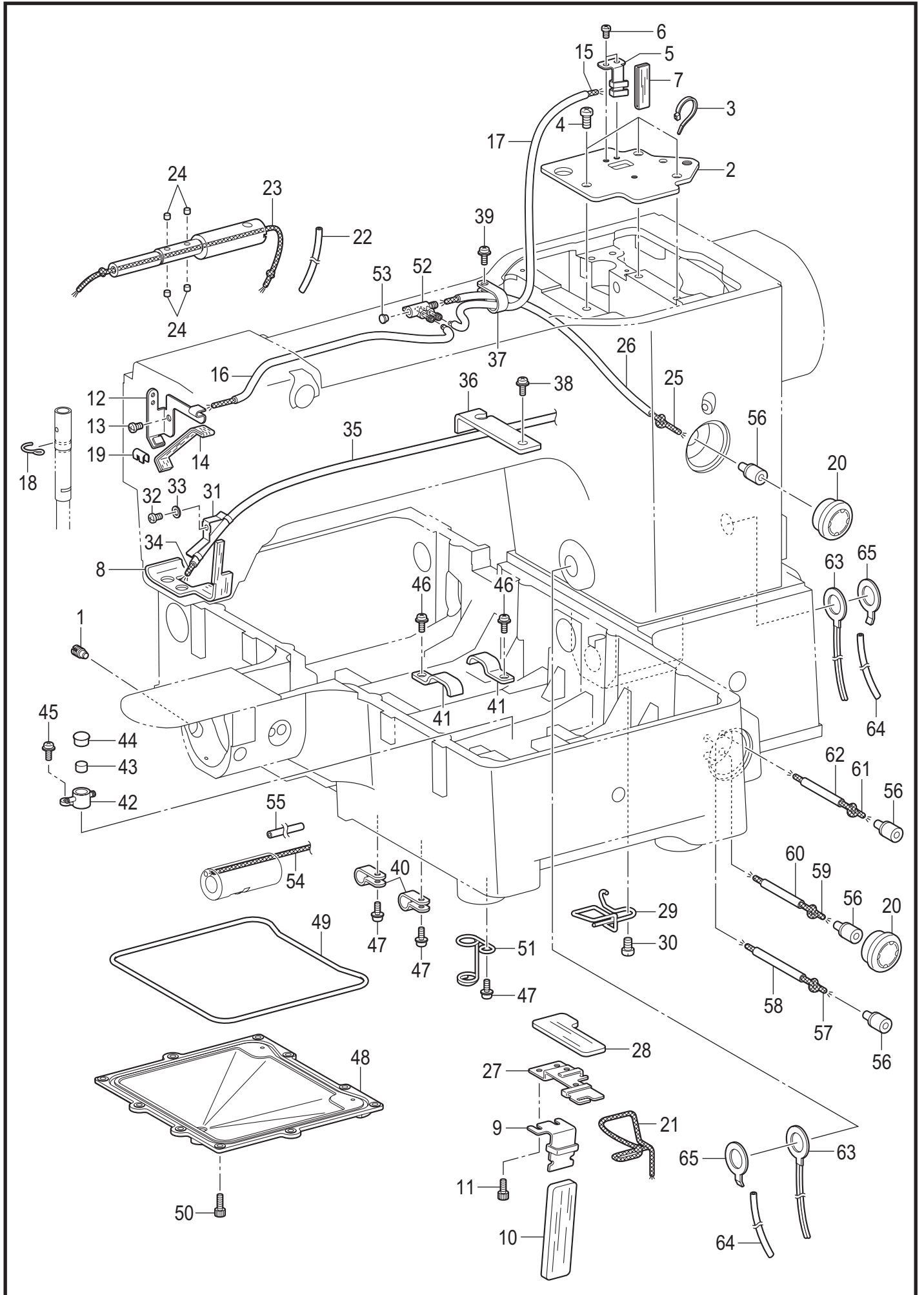

F. 給油潤滑関係 / Lubrication

REF.NO	CODE	Q'TY	品名	NAME OF PARTS	RM
62	S50547000	1	ビニルチューブ	OIL TUBE	
63	SB4352001	2	Yラックジクフェルトクミ	Y-RACK SHAFT FELT ASSY	
64	S50527000	2	ビニルチューブ	OIL TUBE	
65	SB4189001	2	Yラックジクカバー	Y-RACK SHAFT COVER	

BAS-311HN/326H-350

G. 糸通し関係 / Threading mechanism

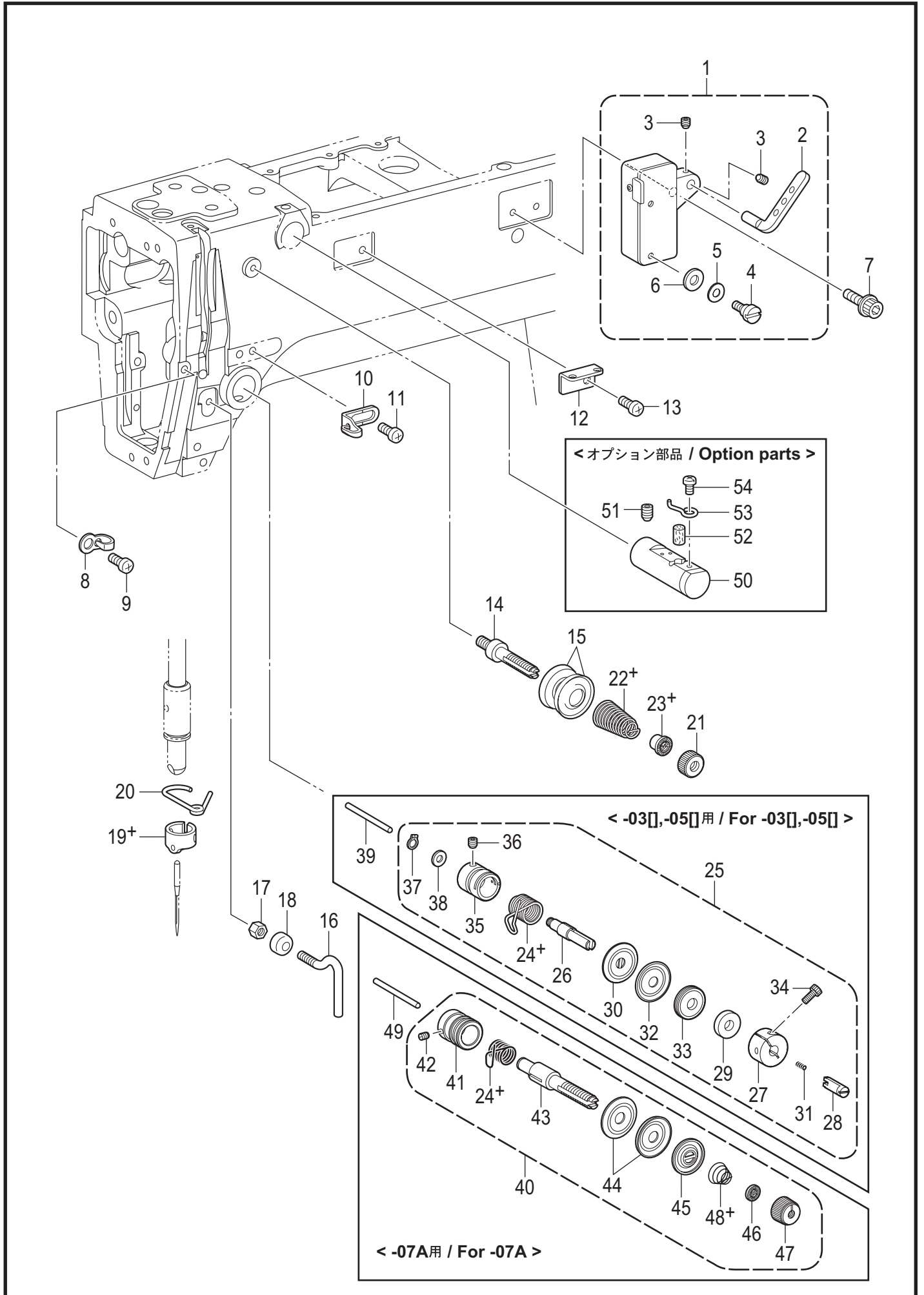

G. 糸通し関係 / Threading mechanism

REF.NO	CODE	Q'TY	品名	NAME OF PARTS	RM
1	SB6587001	1	イトキレセンサソウクミ	THREAD BREAKAGE DETECTOR UNIT	
2	SB2636001	1	ミツメイトカケ	THREAD RETAINER	
3	012500536	2	アナヒラ5×5	SET SCREW SOCKET (FT) M5X5	
4	SA3306001	1	ダンネジ7-3	SHOULDER SCREW, 7-3	
5	120265002	1	ナミバネザガネ	SPRING WASHER	
6	S07350002	1	ザガネ	WASHER PLAIN	
7	S55485001	1	アナボルトザクミ5X12	BOLT SOCKET (S/P WASHER)M5X12	
8	SA4333001	1	ア-ムイトミチB	ARM THREAD GUIDE,B	
9	062500616	1	ナベコ5X6	SCREW PAN M5X6	
10	SA6391001	1	ア-ムイトミチC	ARM THREAD GUIDE C	
11	062500616	1	ナベコ5X6	SCREW PAN M5X6	
12	SB1086001	1	ア-ムイトミチD	ARM THREAD GUIDE D	
13	062500616	1	ナベコ5X6	SCREW PAN M5X6	
14	SA3256001	1	イトチヨウシボウA	TENSION STUD A	
15	145446001	2	イトチヨウシサラ	DISC TENSION	
16	SA8691001	1	ア-ムイトカケ	THREAD GUIDE ARM	
17	021400306	1	3シュナット4	NUT 3 M4	
18	SA9207001	1	ゴムカバー	RUBBER COVER	
19+	P.74	1	ハリボウイトアンナイA	NEEDLE BAR THREAD GUIDE,A	
20	SA3258001	1	ハリボウメタルDイトアンナイ	N-BAR BUSH THREAD GUIDE,D	
21	100136001	1	イトチヨウシナット	TENSION NUT	
22+	P.74	1	フクチヨウシバネ	SUB TENSION SPRING	
23+	P.74	1	チヨウシバネウエザガネ	WASHER	
24+	P.74	1	イトトリバネC	THREAD TAKE-UP SPRING	
			<-03□, -05□用>	<For -03□, -05□>	
25	SB6468002	1	DTイトチヨウシクミ	D TENSION ASSY	
26	SB6433001	1	DTイトチヨウシボウ	DT TENSION STUD	
27	SB1088101	1	セットカラー-DT	SET COLLAR DT	
28	SB1180201	1	キリワリジク	SHAFT	
29	SB1181001	1	DTクッション	DT CUSHION	
30	SA6190001	1	DTイトチヨウシサラ	DISC DT	
31	SB1267001	1	コイルバネ	COIL SPRING	
32	145446001	1	イトチヨウシサラ	DISC TENSION	
33	SB1281001	1	テーパサラオサエ	TAPER DISC PRESSER	
34	018301036	1	アナボルト3X10	BOLT SOCKET M3X10	
35	SB1182101	1	DTイトチヨウシダイクミ	TENSION BRACKET ASSY	
36	012400436	1	アナヒラ4X4	SET SCREW SOCKET (FT) M4X4	
37	048060142	1	トメワジクヨウC6	RETAINING RING EXTERNAL C6	
38	109763022	1	ザガネ	WASHER	
39	SB6264001	1	ピン1.8X25	PIN 1.8X25	
			<-07A用>	<For -07A>	
40	SA3520501		イトチヨウシダイDクミ	TENSION BRACKET D ASSY	
41	SA3254001	1	イトチヨウシダイ	TENSION BRACKET	
42	100402004	1	トメネジ3.57	SET SCREW SM3.57	
43	SA3255001	1	イトチヨウシボウ	TENSION STUD	
44	145446001	2	イトチヨウシサラ	DISC TENSION	
45	159805001	1	イトチヨウシサラオサエ	TENSION DISC PRESSER	
46	S12441001	1	チヨウシバネウエザガネ	WASHER	
47	S31032002	1	イトチヨウシナット	TENSION NUT	
48+	P.74	1	イトチヨウシバネ	TENSION SPRING	
49	S12699001	1	イトユルメピン	TENSION RELEASE PIN	
			<オプション部品>	<Option parts>	
50	152881101	1	エキレイタイクミ	NEEDLE COOLER ASSY	
51	012060636	1	アナヒラ6X6	SET SCREW SOCKET (FT) M6X6	
52	152883000	1	フェルト8X15.5	FELT, 8X15.5	
53	152884001	1	エキレイイトカケ	NEEDLE COOLER THREAD GUIDE	
54	062670412	1	ナベコ357-40X4	SCREW PAN SM3.57-40X4	

H. 糸巻関係 / Bobbin winder mechanism

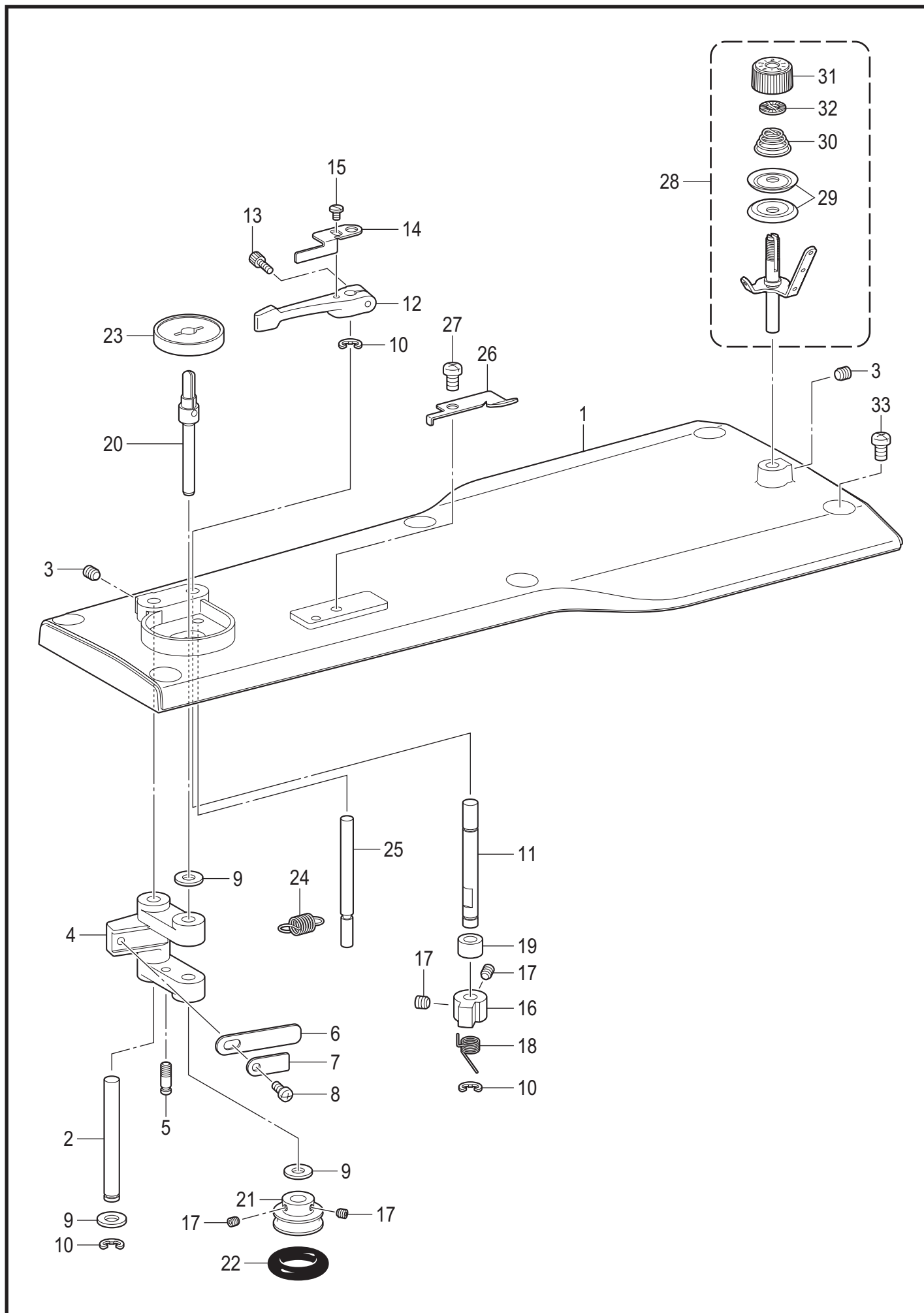

BAS-311HN/326H-402

H. 糸巻関係 / Bobbin winder mechanism

REF.NO	CODE	Q'TY	品名	NAME OF PARTS	RM
1	SB4389001	1	ウワフタ311H	TOP COVER 311H	
2	SA3290001	1	イトマキレバージク	SHAFT,BW-LEVER	
3	012500536	2	アナヒラ5X5	SET SCREW SOCKET (FT) M5X5	
4	SA3291001	1	イトマキレバー	BOBBIN WINDER LEVER	
5	SA4171001	1	バネカケ	SPRING HOOK	
6	152936001	1	イタバネ	PLATE SPRING	
7	152937001	1	ザガネ	WASHER	
8	062350616	1	ナベコ35X6	SCREW PAN M3.5X6	
9	155559021	3	ヒラザガネ	WASHER PLAIN	
10	048050342	3	トメワE5	RETAINING RING E5	
11	SA3293001	1	イトマキツメジク	STUD B-WINDER CLAW	
12	SA1984001	1	ボビンオサエウデ	BOBBIN PRESSER ARM	
13	018401236	1	アナボルト4X12	BOLT SOCKET M4X12	
14	SA3294001	1	ボビンオサエ	BOBBIN PRESSER	
15	S23418002	1	シメネジ4X5	SCREW M4X5	
16	SA3295001	1	イトマキツメ	CLAW B-WINDER	
17	012400436	4	アナヒラ4X4	SET SCREW SOCKET (FT) M4X4	
18	S10438001	1	イトマキツメネジリバネ	SPRING, TWIST	
19	SA4796001	1	スペーサーカラー	SPACER COLLER	
20	SA3296001	1	イトマキジク	BOBBIN WINDER SHAFT	
21	SA3297001	1	イトマキクルマ	WHEEL,B-WINDER	
22	120448001	1	ゴムワ	BOBBIN WINDER RUBBER BAND	
23	SA1988001	1	ボビンウケ	BOBBIN SUPPORT	
24	S10268001	1	イトマキレバーヒキバネ	SPRING	
25	SA3298001	1	ストツパジク	STPPER SHAFT,B-WINDER	
26	SA3299001	1	メス	KNIFE	
27	062500616	1	ナベコ5X6	SCREW PAN M5X6	
28	SB1253001	1	イトマキチョウシクミ	BOBBIN WINDER TENSION ASSY	
29	145446002	2	イトチョウシサラ	DISC TENSION	
30	100401022	1	イトチョウシバネ	TENSION SPRING	
31	S31032002	1	イトチョウシナット	TENSION NUT	
32	S12441001	1	チョウシバネウエザガネ	WASHER	
33	062061016	6	ナベコ6X10	SCREW PAN M6X10	

J. 糸切り関係 / Thread trimmer mechanism

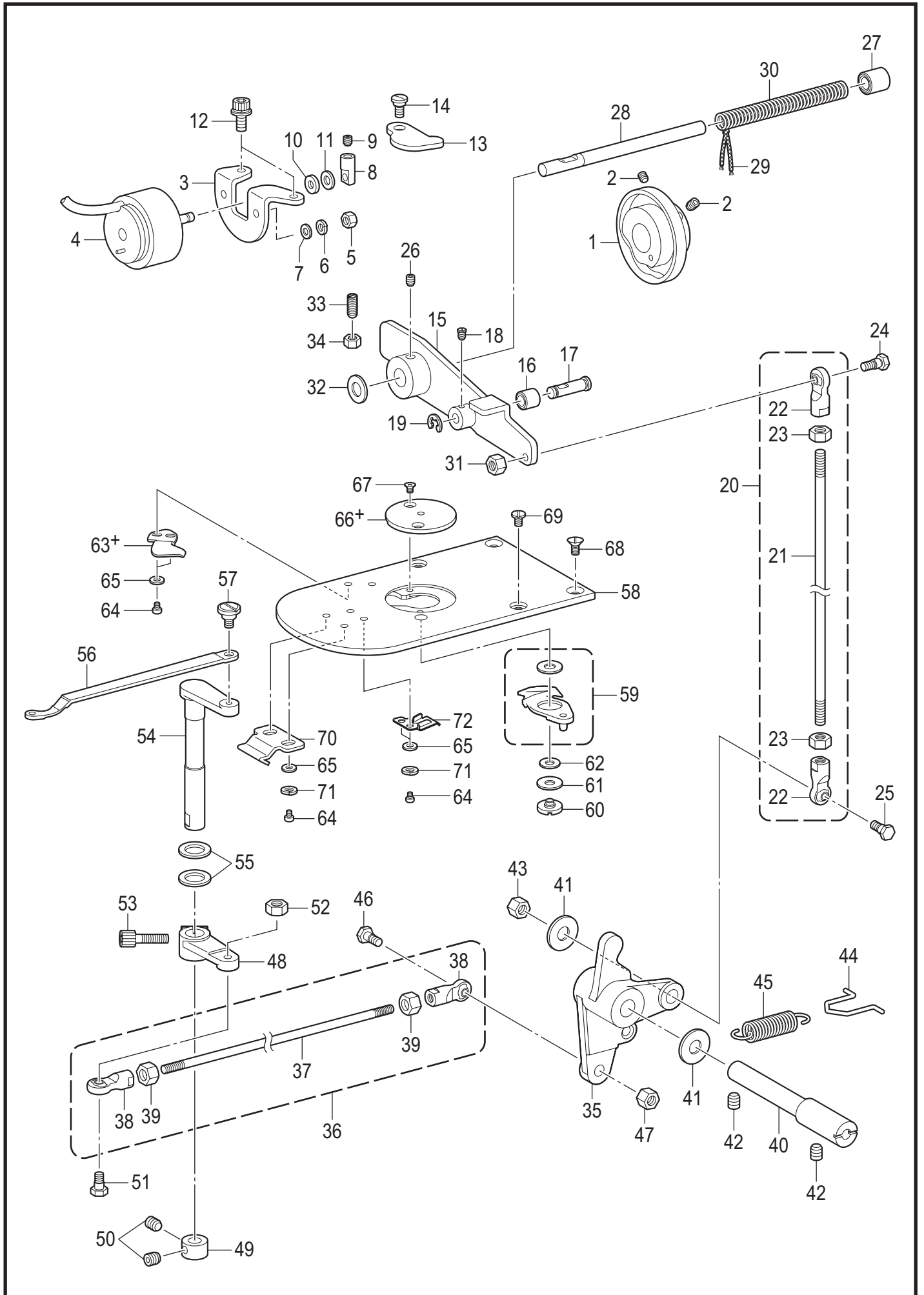

J. 糸切り関係 / Thread trimmer mechanism

REF.NO	CODE	Q'TY	品名	NAME OF PARTS	RM
1	SA4131001	1	イトキリカム	THREAD TRIMMER CAM	
2	S23651001	2	アナヒラ6X6ホソメ	SET SCREW SOCKET (FT) M6X6	
3	SA4798001	1	ソレノイドトリツケイタ	SETTING PLATE SOLENOID	
4	SB6577001	1	イトキリソレノイド	THREAD TRIMMER SOLENOID	
5	021400216	2	2シュナット4	NUT 2 M4	
6	028040246	2	バネザガネ2-4	WASHER SPRING 2-4	
7	SB3848001	2	ヒラザガネチュウ4	WASHER PLAIN M 4	
8	SA3307001	1	ソレノイドレバー	SOLENOID LEVER	
9	012400436	1	アナヒラ4X4	SET SCREW SOCKET (FT) M4X4	
10	154599000	1	ソレノイドクツシヨン	SOLENOID CUSHION	
11	S02652021	1	ザガネ	WASHER	
12	S55484001	2	アナボルトザクミ5X10	BOLT SOCKET (S/P WASHER)M5X10	
13	SA4799001	1	クドウレバー-オシレバー	PUSHING LEVER D-LEVER	
14	SA3306001	1	ダンネジ7-3	SHOULDER SCREW,7-3	
15	SA3309201	1	イトキリクドウレバー	TR-DRIVING LEVER	
16	SA3310001	1	イトキリコロ	COLLAR TR-TRIMMER	
17	SA3311001	1	イトキリコロジク	COLLAR SHAFT	
18	S46903001	1	アタマツキトメネジ4X5	SET SCREW, M4X5	
19	048040342	1	トメワE4	RETAINING RING E4	
20	SB4416001	1	イトキリロッドVクミ	THREAD TRIMMER ROD ASSY V	
21	SB4393001	1	イトキリロッドV	THREAD TRIMMER ROD V	
22	S32465101	2	タマツギテクミ	BALL JOINT ASSY	
23	021060306	2	3シュナット6	NUT 3 M6	
24	SB4401001	1	ダンネジ6.35-6	SHOULDER SCREW 6.35-6	
25	SB4401001	1	ダンネジ6.35-6	SHOULDER SCREW 6.35-6	
26	S23651001	1	アナヒラ6X6ホソメ	SET SCREW SOCKET (FT) M6X6	
27	231071001	1	メタル8X15	BUSH, 8X15	
28	SA3312201	1	クドウレバー-アンナイジク	GUIDE SHAFT	
29	SA6572001	1	クミヒモ	WICK L=140	
30	SA3313101	1	クドウジクバネ	SPRING,COMPRESSION	
31	021060306	1	3シュナット6	NUT 3 M6	
32	154596000	1	イトキリカムレバー-クツシヨン	CUSHION	
33	S25475101	1	トメネジ6	SET SCREW M6X19	
34	021060106	1	1シュナット6	NUT 1 M6	
35	SB4397001	1	イトキリレバー	THREAD TRIMMER LEVER	
36	SB4415001	1	イトキリロッドHクミ	THREAD TRIMMER ROD ASSY H	
37	SB4391001	1	イトキリロッドH	THREAD TRIMMER ROD H	
38	S32465101	2	タマツギテクミ	BALL JOINT ASSY	
39	021060306	2	3シュナット6	NUT 3 M6	
40	SB4399001	1	イトキリレバー-ジク	SHAFT TR-TRIMMER LEVER	
41	SA4545001	2	カンザ	SPACER	
42	012060636	2	アナヒラ6X6	SET SCREW SOCKET (FT) M6X6	
43	021060306	1	3シュナット6	NUT 3 M6	
44	SB4398001	1	バネカケ	SPRING HOOK	
45	SA3321001	1	イトキリモシバネ	SPRING,EXTENSION	
46	SB4401001	1	ダンネジ6.35-6	SHOULDER SCREW 6.35-6	
47	021060306	1	3シュナット6	NUT 3 M6	
48	SB4395001	1	イドウハレバー	MOVING KNIFE LEVER	
49	SA4588001	1	セットカラー	SET COLLAR	
50	012500536	2	アナヒラ5X5	SET SCREW SOCKET (FT) M5X5	
51	SB4401001	1	ダンネジ6.35-6	SHOULDER SCREW 6.35-6	
52	021060306	1	3シュナット6	NUT 3 M6	
53	018061636	1	アナボルト6X16	BOLT SOCKET M6X16	
54	SB4396001	1	イドウハレバー-ジク	SHAFT MOVABLE KNIFE LEVER	
55	SB4400001	2	スラストザガネ	THRUST WASHER	
56	SB4394001	1	イドウハレンカン	M-KNIFE CONNECTING PLATE	
57	SA4354001	1	ダンネジ6-1.8	SHOULDER SCREW,6-1.8	
58	SB4595001	1	ハリイタ	NEEDLE PLATE	
59	SA6596001	1	イドウハFセット	MOVABLE KNIFE SET F	
60	SA4518001	1	イドウハダンネジ	MOVABLE KNIFE SHOULDER SCREW	
61	SA4519001	1	スラストザガネ	THRUST WASHER	

J. 糸切り関係 / Thread trimmer mechanism

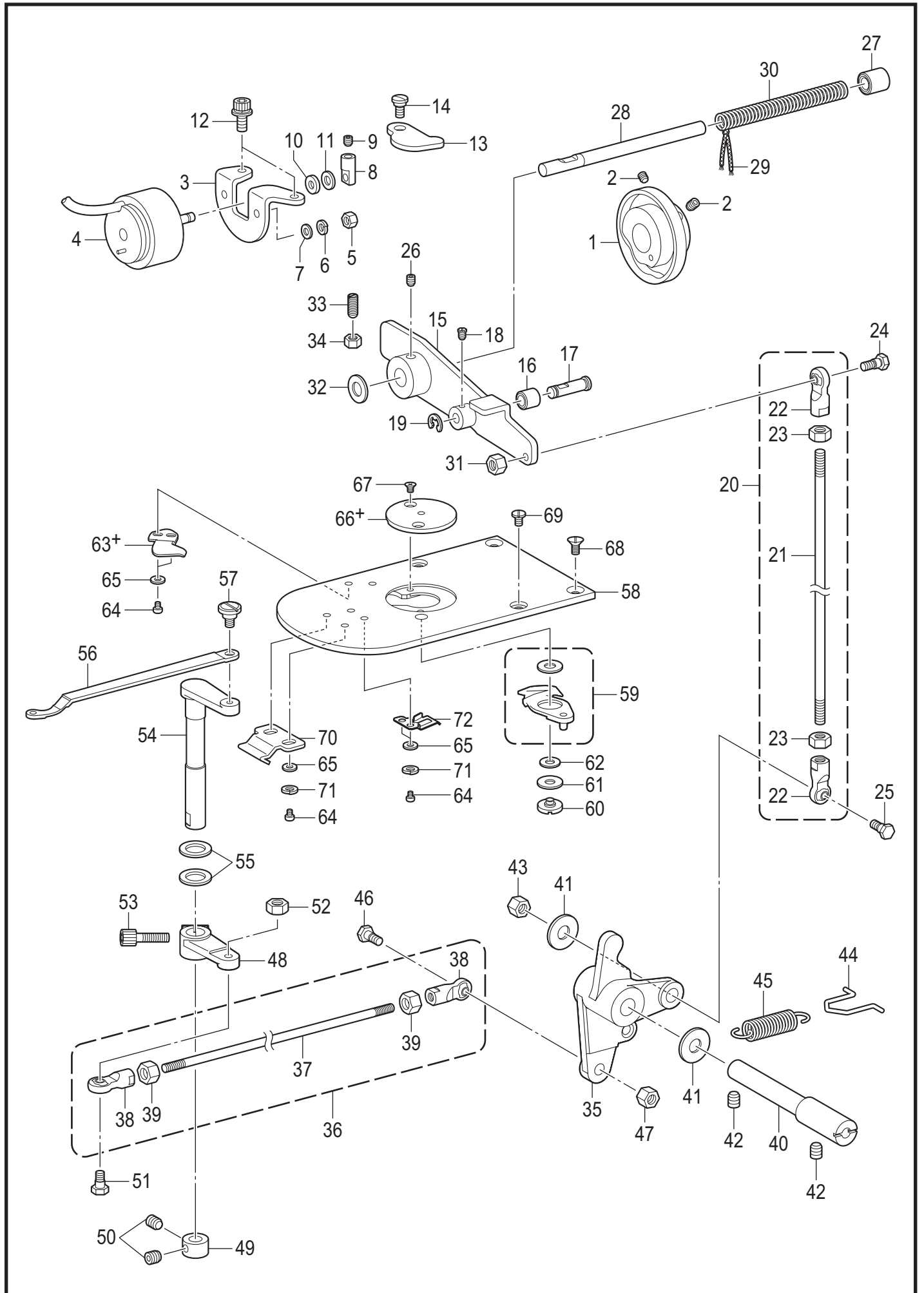

J. 糸切り関係 / Thread trimmer mechanism

REF.NO	CODE	Q'TY	品名	NAME OF PARTS	RM
62	S00705001	1	イドウハカラ-	MOVABLE KNIFE COLLAR	
63+	P.73	1	コテイハFL	FIXED KNIFE FL	
64	062300416	6	ナベコ3X4	SCREW PAN M3X4	
65	SB3847001	6	ヒラザガネチュウ3	WASHER_PLAIN_M_3	
66+	P.73	1	ハリアナイタ2.2	NEEDLE HOLE PLATE 2.2	
67	100360003	2	サラネジ2.38	SCREW	
68	S25310101	2	サラネジ4	SCREW, FLAT M4	
69	SA3538001	2	シメネジ4X8	SCREW,M4X8	
70	SA6273101	1	オオカマカバーフツクU	SHUTTLE RACE COVER HOOK U	
71	028030246	4	バネザガネ2-3	WASHER SPRING 2-3	
72	SB0713001	1	シタイトオサエバネ	BOBBIN THREAD CLAMP SPRING	

K. 糸払い関係 / Thread wiper mechanism

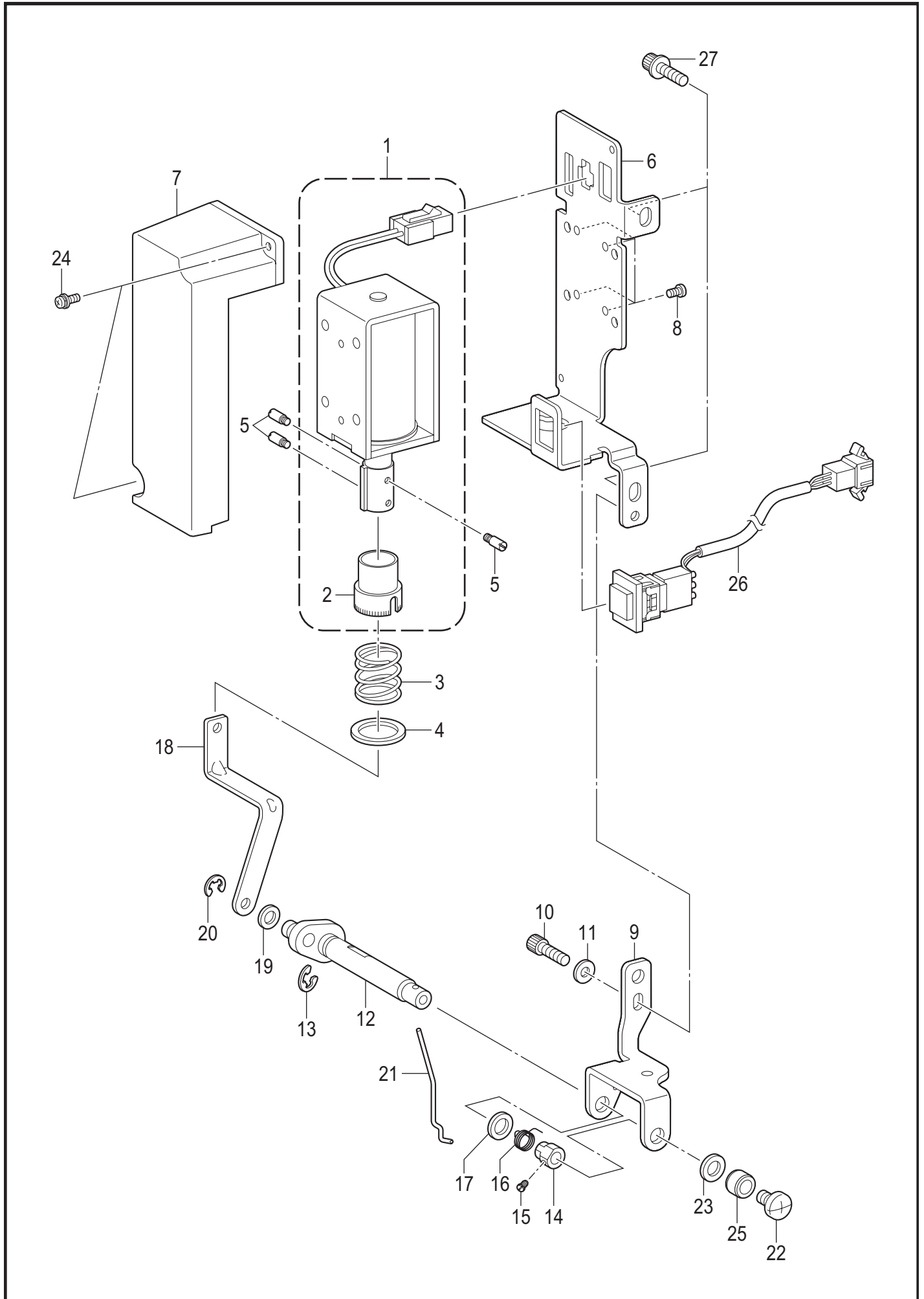

K. 糸払い関係 / Thread wiper mechanism

REF.NO	CODE	Q'TY	品名	NAME OF PARTS	RM
1	SB4297101	1	イトハライソレノイドクミ	THREAD WIPER SOLENOID ASSY	
2	SA9853101	1	プランジャゴム	PLUNGER RUBBER	
3	S41206001	1	イトハライバネ	THREAD WIPER SPRING	
4	S41205001	1	ヒラザガネ	WASHER, PLAIN	
5	S25456021	3	プランジャピン	PLUNGER PIN	
6	SB4379001	1	イトハライソレノイドトリツケイ	T-WIPER SOLENOID SETTING PLATE	
7	SA4806101	1	ソレノイドカバー	SOLENOID COVER	
8	062300616	4	ナベコ3X6	SCREW PAN M3X6	
9	SB4378001	1	イトハライジクウケイタ	THREAD WIPER SHAFT BRACKET	
10	018400836	1	アナボルト4X8	BOLT SOCKET M4X8	
11	SB3848001	1	ヒラザガネチュウ4	WASHER_PLAIN_M_4	
12	SA8057001	1	イトハライクランククミ	THREAD WIPER CRANK ASSY	
13	048040342	1	トメワE4	RETAINING RING E4	
14	S25454021	1	セツトカラー	SET SCREW COLLAR	
15	S25279101	1	アタマトメクボミM35-5	SET SCREW (CP) M3.5-5	
16	SA2287001	1	ワイパーバネ	SPRING	
17	149097000	1	シヨウオンシート	SILENT SHEET	
18	SA5219001	1	イトハライロッド	THREAD WIPER ROD	
19	110735022	1	ザガネ	WASHER	
20	048030342	1	トメワE3	RETAINING RING E3	
21	S10470201	1	ワイパー	WIPER	
22	060400516	1	バインド4X5	SCREW BIND M4X5	
23	S03677001	1	ザガネ	WASHER	
24	0A4300806	2	+ナベザクミ3X8DA	SCREW PAN (S/P WASHER) M3X8	
25	146288021	1	イトハライジクカラー	THREAD WIPER STUD COLLAR	
26	SA5213001	1	テイシSWクミ	STOP SWITCH ASSY	
27	S55485001	2	アナボルトザクミ5X12	BOLT SOCKET (S/P WASHER)M5X12	

L1.糸ゆるめ関係(デジタルテンションソレノイド) / Tension release mechanism (Digital tension solenoid)

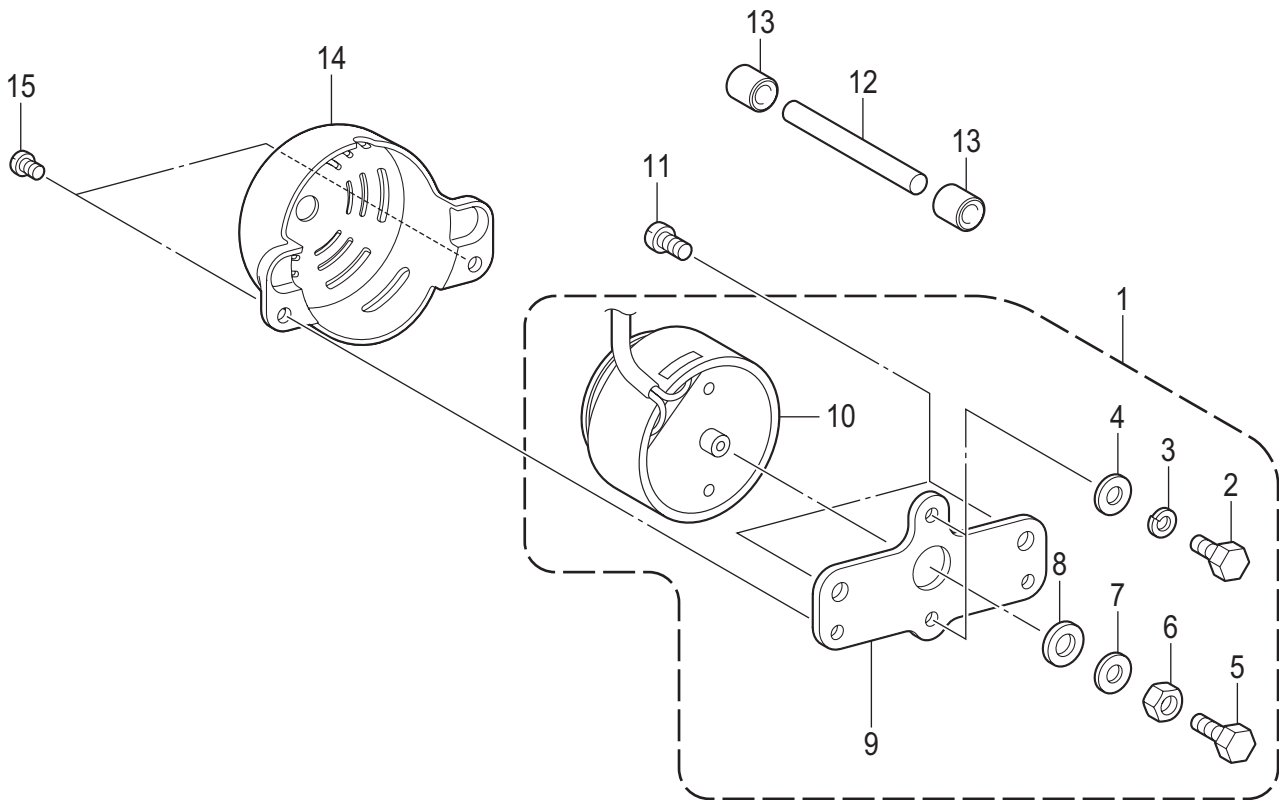

L1. 糸ゆるめ関係(デジタルテンションソレノイド) / Tension release mechanism (Digital tension solenoid)

REF.NO	CODE	Q'TY	品名	NAME OF PARTS	RM
1	SB6467001	1	DTソレノイドクミ	DT SOLENOID ASSY	
2	017400802	2	ボルト4X8	BOLT M4X8	
3	028040246	2	バネザガネ2-4	WASHER SPRING 2-4	
4	SB3848001	2	ヒラザガネチュウ4	WASHER PLAIN M 4	
5	017401015	1	ボルト4X10	BOLT M4X10	
6	021400306	1	3シュナット4	NUT 3 M4	
7	025040332	1	ヒラザガネダイ4	WASHER PLAIN L 4	
8	SB1179001	1	ソレノイドクッション	SOLENOID CUSHION	
9	SB4380001	1	ソレノイドトリツケイタ	SETTING PLATE SOLENOID	
10	SB0794101	1	テンションソレノイド	DT TENSION SOLENOID	
11	062500816	2	ナベコ5X8	SCREW PAN M5X8	
12	SB6261001	1	シャフト3X50	SHAFT 3X50	
13	SB1192001	2	イトユルメボウヨウブシュ	TENSION RELEASE BAR BUSH	
14	SB0787101	1	ソレノイドカバー	SOLENOID COVER	
15	060400516	2	バインド4X5	SCREW BIND M4X5	

L2. 糸ゆるめ関係 (糸ゆるめソレノイド) / Tension release mechanism (Tension release solenoid)

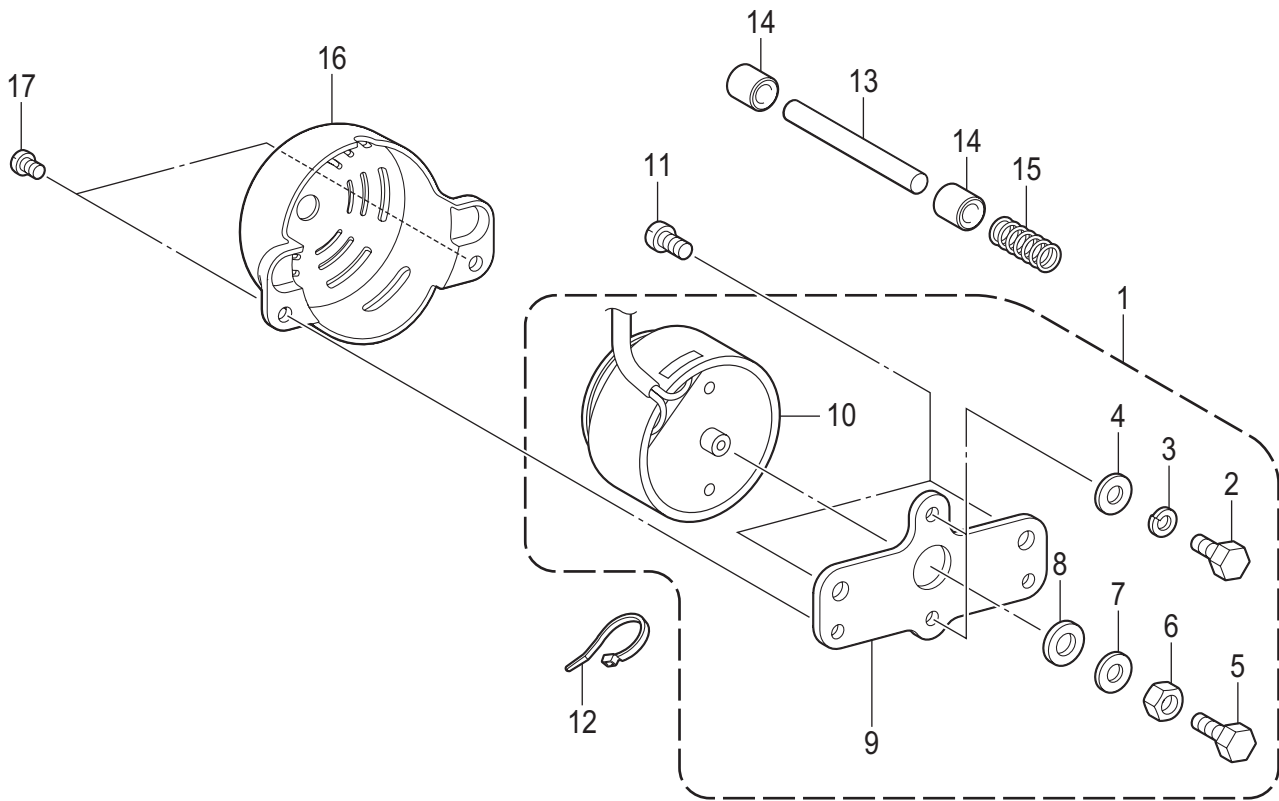

L2. 糸ゆるめ関係 (糸ゆるめソレノイド) / Tension release mechanism (Tension release solenoid)

REF.NO	CODE	Q'TY	品名	NAME OF PARTS	RM
1	SB4467101	1	イトユルメクミ	TENSION RELEASE SOLENOID ASSY	
2	017400802	2	ボルト4X8	BOLT M4X8	
3	028040246	2	バネザガネ2-4	WASHER SPRING 2-4	
4	SB3848001	2	ヒラザガネチュウ4	WASHER_PLAIN_M_4	
5	017401415	1	ボルト4X14	BOLT M4X14	
6	021400306	1	3シュナット4	NUT 3 M4	
7	025040332	1	ヒラザガネダイ4	WASHER PLAIN L 4	
8	SB1179001	1	ソレノイドクツシヨン	SOLENOID CUSHION	
9	SB4380001	1	ソレノイドトリツケイタ	SETTING PLATE SOLENOID	
10	SB0794101	1	テンシヨソレノイド	DT TENSION SOLENOID	
11	062500816	2	ナベコ5X8	SCREW PAN M5X8	
12	SB4155001	1	バンド	BAND	
13	SB6261001	1	シャフト3X50	SHAFT 3X50	
14	SB1192001	2	イトユルメボウヨウブシュ	TENSION RELEASE BAR BUSH	
15	SB4486001	1	イトユルメバネ	PRESSER FOOT D	
16	SB0787101	1	ソレノイドカバー	SOLENOID COVER	
17	060400516	2	バインド4X5	SCREW BIND M4X5	

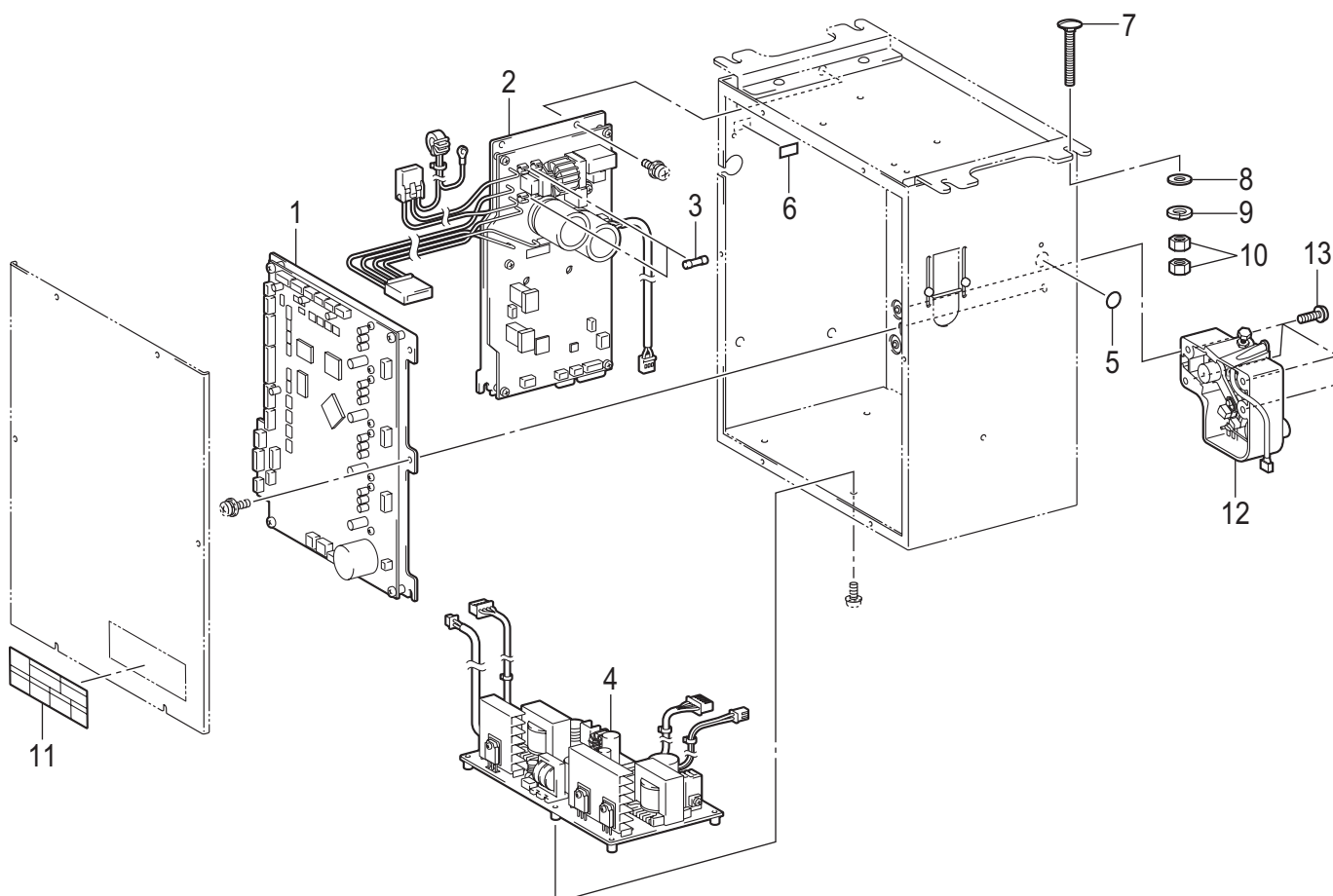
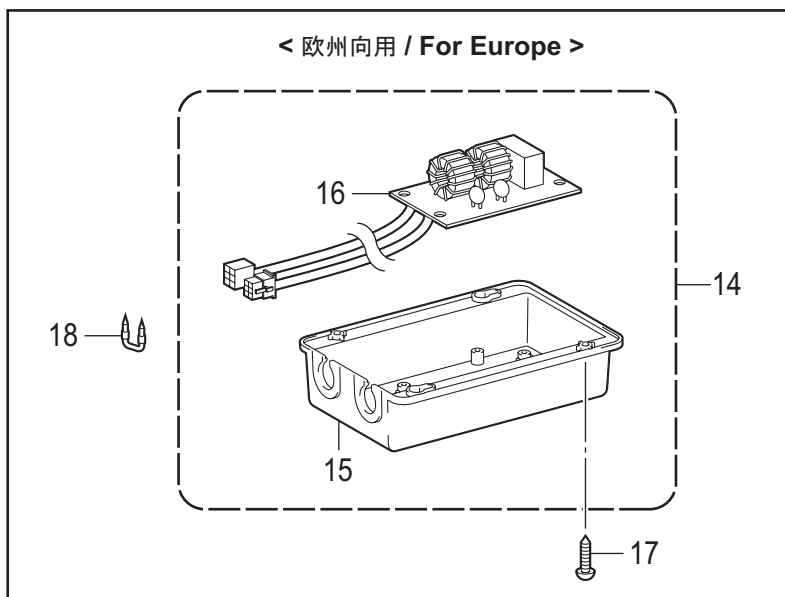

M1. コントロールボックス関係 / Control box

REF.NO	CODE	Q'TY	品名	NAME OF PARTS	RM
1	SB6414001	1	メインキバンクミ 311H SA	MAIN PCB ASSY 311H S/A	
2	SB4541101	1	モータキバンクミ 311H	MOTOR PCB ASSY 311H	
3	J04417001	2	Gヒューズ10A-250V	G FUSE 10A-250V:FGMB	
4	SA9500201	1	デンゲンキバンクミ	POWER PCB ASSY	
5	S37060001	1	ア-スマーク	LABEL, GROUNDING	
6	S37059001	1	PEマーク	LABEL, PE	
7	SA9893001	4	カクネボルト8X65	BOLT M8X65	
8	025080336	4	ヒラザガネダイ8	WASHER PLAIN L 8	
9	028080246	4	バネザガネ2-8	WASHER SPRING 2-8	
10	021080206	8	2シュナット8	NUT 2 M8	
11	SA9725001	1	ラベルカンデン6カコク	LABEL ELECTRICAL SHOCK 36X150	
12	SA9602101	1	フミコムユニット-ユ	TREADLE UNIT -EX	
13	J00353001	4	+ナベセット5X14DB	SCREW PAN (S/P WASHER) M5X14	
			<欧州向用>	<For Europe>	
14	SA9559001	1	CE フィルタ クミ	CE FILTER BOX ASSY	
15	SA9564001	1	CEフィルターケース	CE FILTER CASE	
16	SA9565001	1	CEフィルタキバンクミ	CE FILTER PCB ASSY	
17	S03816001	4	+マルモク45X16	WOOD SCREW M4.5X16	
18	200190001	5	ステツプル 10X20	STAPLE 10X20	

M2. コントロールボックス関係 / Control box

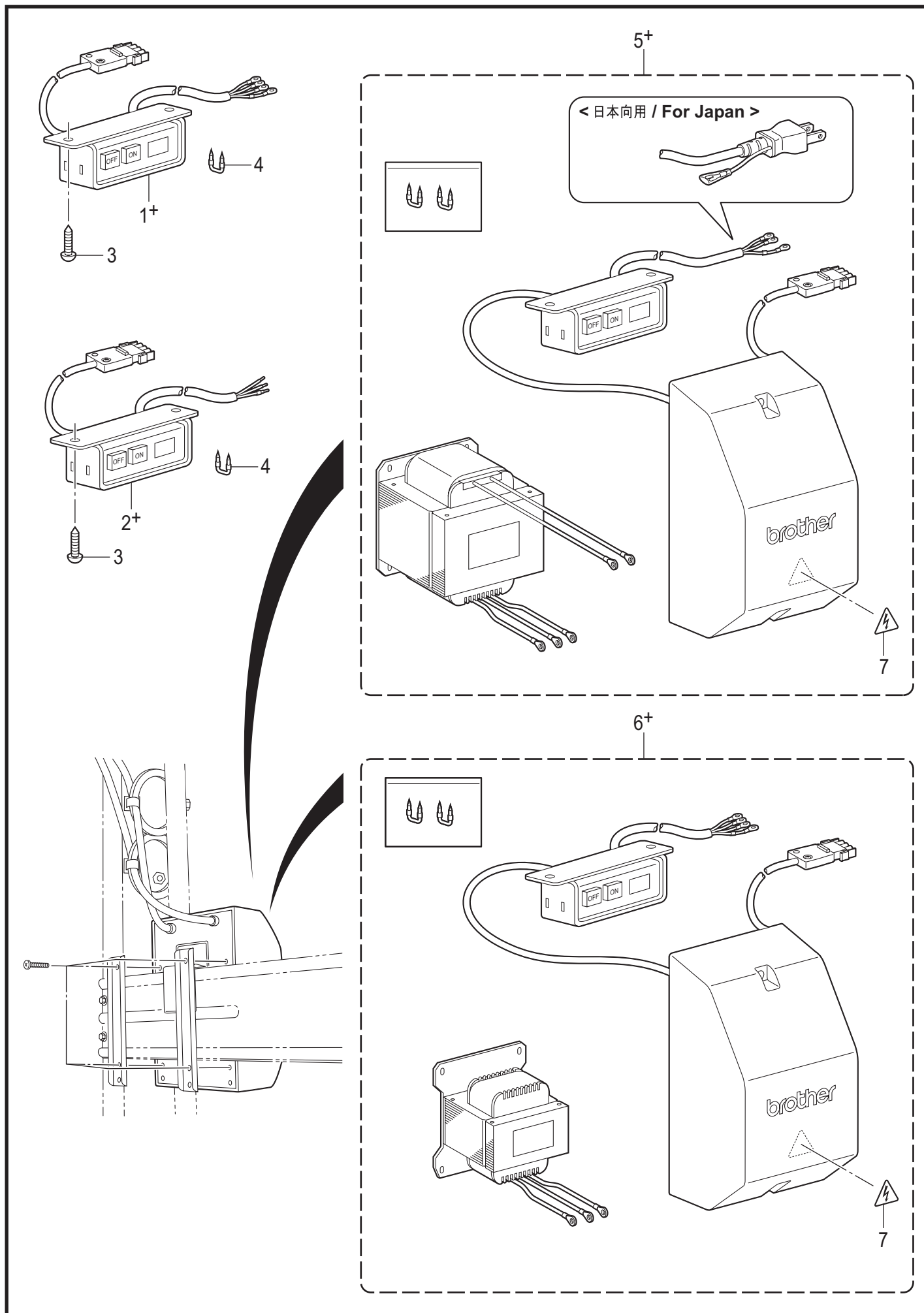

M2. コントロールボックス関係 / Control box

REF.NO	CODE	Q'TY	品名	NAME OF PARTS	RM
1+	SA9616001	1	<三相 200V AC 用> <日本向用> デンSW クミ SJT	<For Three phase 200V AC> <For Japan> POWER SWITCH ASSY SJT	
1+	SA9831001	1	<三相 220V AC 用> <米州向用> デンSW クミ SJT#2	<For Three phase 220V AC> <For the Americas> POWER SWITCH ASSY SJT#2	
2+	SA9535001	1	<单相 220V AC用> <アジア・一般・欧州向用> デンSWクミCCC	<For Single phase 220V AC> <For Asia, General and Europe> POWER SUPPLY SWITCH ASSY CCC	
2+	BMP3010-0000001-3S00	1	<单相 220V AC用> <中国向用> デンゲンSW 220V	<For Single phase 220V AC> <For China> POWER SWITCH 220V	
3	S03816001	2	+マルモク45X16	WOOD SCREW M4.5X16	
4	200190001	2	ステツブル 10X20	STAPLE 10X20	
5+	SB1229001	1	<单相 100V用> <日本向用> トランスボックスホキユウクミ	<For Single phase 100V> <For Japan> TRANCE BOX 100V SUPPLY	
5+	BMP3010-0000000-2ST1	1	<米州向用> トランスボックス	<For the Americas> TRANSFORMER BOX	
6+	BMP3010-0000000-3ST4	1	<三相 380V用> <アジア・一般向用> トランスボックス	<For Three phase 380V> <For General and Asia> TRANSFORMER BOX	
6+	BMP3010-0000001-3ST4	1	<中国向用> トランスボックス	<For China> TRANSFORMER BOX	
6+	BMP3010-0000000-4ST4	1	<三相 400V用> <欧州向用> トランスボックス	<For Three phase 400V> <For Europe> TRANSFORMER BOX	
7	SA9914001	1	ラベルカンデン 25 X 28	LABEL ELECTRICAL SHOCK 25 X 28	

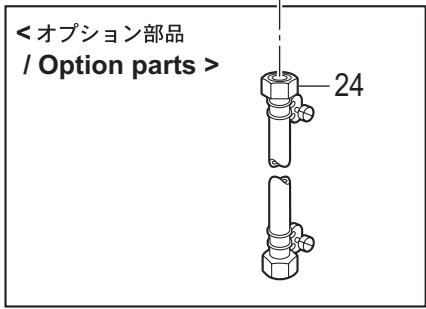
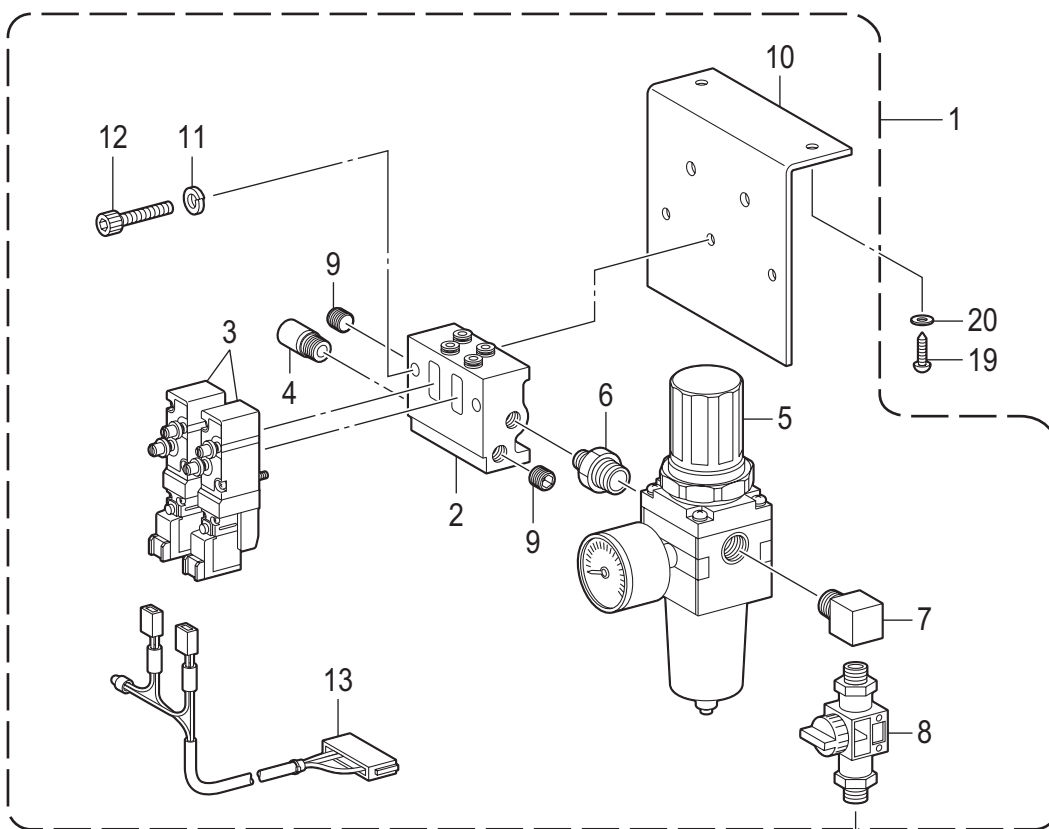
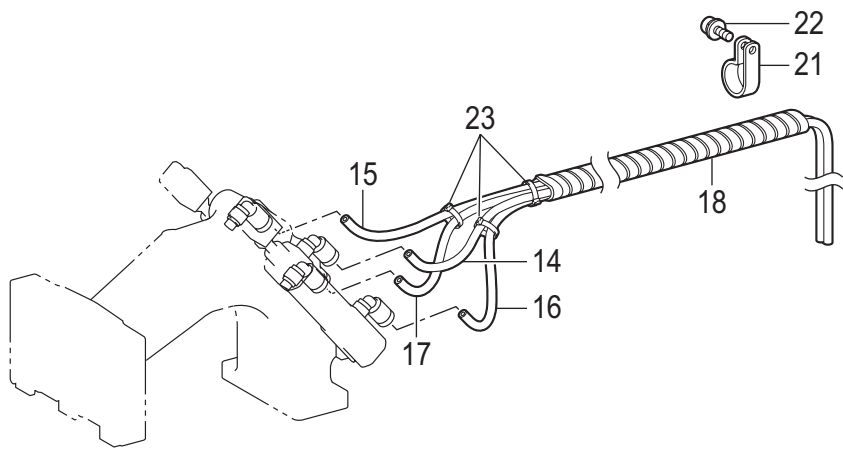

N. 空圧関係 / Air pressure mechanism

REF.NO	CODE	Q'TY	品名	NAME OF PARTS	RM
1	SA5281201	1	デンジバルブ2Aクミ	SOLENOID VALVE ASSY 2A	
2	SA5289001	1	マニホールド2	MANIFOLD2	
3	S39116100	2	バルブVQZ2151S-5	VALVE VQZ2151S-5	
4	SA5283001	1	サイレンサ AN10-1	SILENCER AN10-1	
5	SA5282001	1	レギュレータ AW20-02G	FILTER REGULATOR AW20-02G	
6	S09228000	1	イケイニツプル	NIPPLE 1/4X1/8	
7	SA7588001	1	PTエルボ1/4	ELBOW PT 1/4	
8	SB0445001	1	フィンガーバルブ	FINGER VALVE	
9	153274001	2	1/8トメセン	CAP, 1/8	
10	SA5286101	1	バルブトリツケイタ	SETTING PLATE VALVE	
11	028050246	2	バネザガネ2-5	WASHER SPRING 2-5	
12	018503036	2	アナボルト5X30	BOLT SOCKET M5X30	
13	SA5191001	1	バルブハーネス2レンクミ	VALVE HARNESS X2 ASSY	
14	SA6405001	1	ナイロンチューブR	AIR TUBE R	
15	SA6406001	1	ナイロンチューブL	AIR TUBE L	
16	SA6405002	1	ナイロンチューブR	AIR TUBE R	
17	SA6406002	1	ナイロンチューブL	AIR TUBE L	
18	SA6407001	1	スパイラル470S	SPIRAL,470S	
19	032422003	2	+2マルモク41X20	WOOD SCREW, ROUND 2 M4.1X20	
20	148847001	2	ザガネ	WASHER PLAIN 4.76	
21	149287000	1	ナイロンクランプ	CORD HOLDER 7N	
22	0A5401006	1	+ナベザクミ4X10DB	SCREW PAN (S/P WASHER) M4X10	
23	228475000	3	ケツソクバンド1.9X80	FASTENING BAND 1.9X80	
24	149796001	1	<オプション部品> ゴムホースカナグツキ	<Option parts> AIR HOSE W/CONNECTOR	

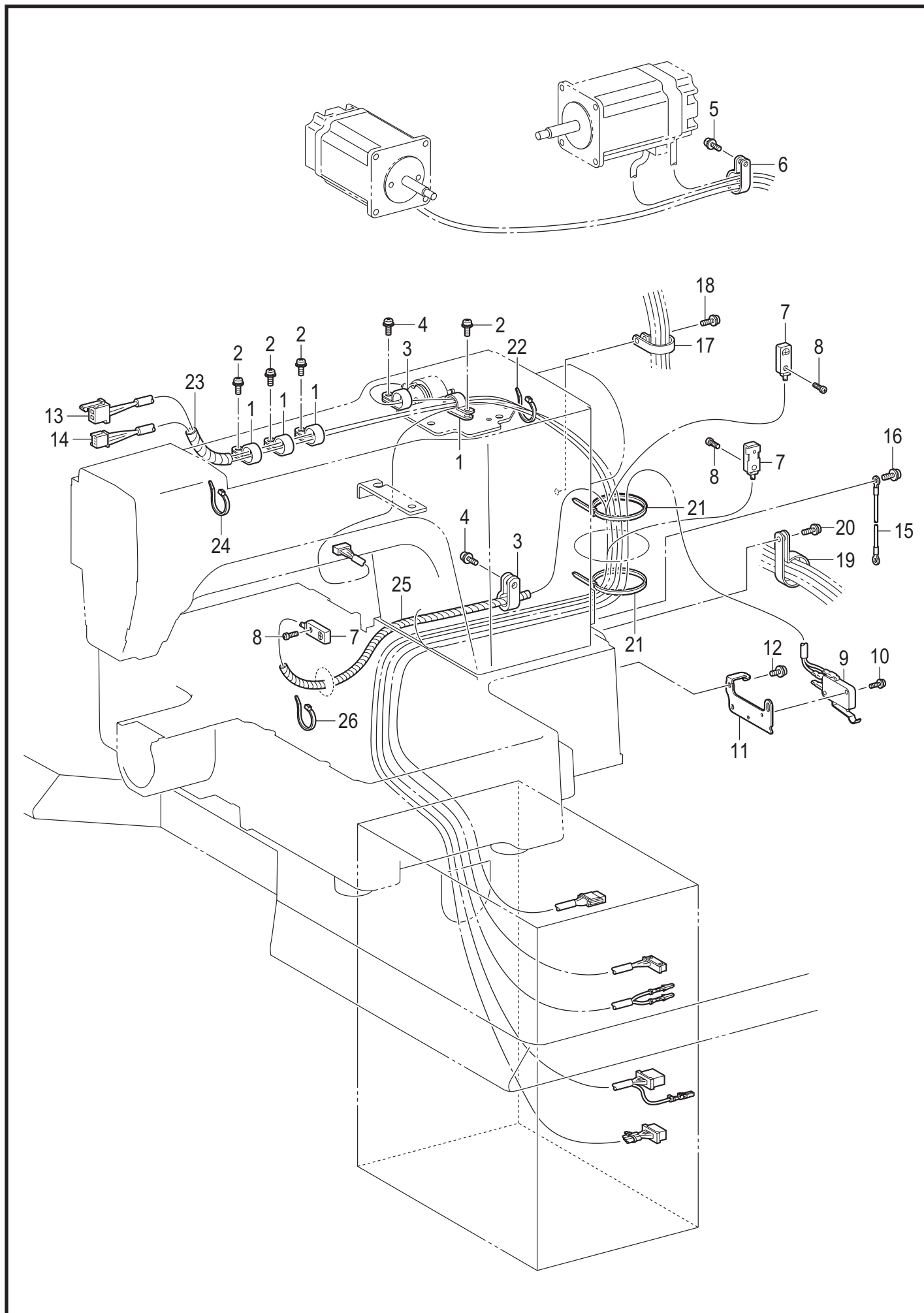

P. 電装品関係 / Power supply equipment

REF.NO	CODE	Q'TY	品名	NAME OF PARTS	RM
1	525567000	4	コードホルダ#8	CORD HOLDER #8	
2	0A5401006	4	+ナベザクミ4X10DB	SCREW PAN (S/P WASHER) M4X10	
3	149547000	2	コードオサエ	CORD HOLDER 4N	
4	0A5401006	2	+ナベザクミ4X10DB	SCREW PAN (S/P WASHER) M4X10	
5	552907000	1	コードホルダ#10	CORD HOLDER #10	
6	0A5401006	1	+ナベザクミ4X10DB	SCREW PAN (S/P WASHER) M4X10	
7	SB4260001	1	ゲンテンセンサクミ	H-POSITION SENSOR ASSY	
8	062300816	3	ナベコ3X8	SCREW PAN M3X8	
9	SB4296101	1	トウブSWクミ	SWITCH ASSY MACHINE HEAD	
10	0A5301605	2	+ナベザクミ3X16DB	SCREW PAN (S/P WASHER) M3X16	
11	SB1200101	1	トウブSWトリツケイタ	SWITCH MACHINE HEAD PLATE	
12	0A5401006	2	+ナベザクミ4X10DB	SCREW PAN (S/P WASHER) M4X10	
13	SA5210001	1	イトハライソレノイドハーネス	THREAD WIPER SOLENOID HARNESS	
14	SB4259001	1	テイシSWハーネス	STOP SWITCH HARNESS 311H	
15	SB4261001	1	アースセン	GROUND WIRE HEAD-BOX	
16	0A5401006	1	+ナベザクミ4X10DB	SCREW PAN (S/P WASHER) M4X10	
17	SB4096001	1	コードホルダ#12	CORD HOLDER #12	
18	0A5401006	1	+ナベザクミ4X10DB	SCREW PAN (S/P WASHER) M4X10	
19	S00470000	1	コードホルダ-#16	CORD HOLDER 16N	
20	0A5401006	1	+ナベザクミ4X10DB	SCREW PAN (S/P WASHER) M4X10	
21	218859001	2	バインダM150	BINDER M150	
22	SB4155001	1	バンド	BAND	
23	SA6366001	1	スパイラル140S	SPIRAL TUBE	
24	SB4155001	1	バンド	BAND	
25	SA6560101	1	スパイラル140SS	SPIRAL, 140SS	
26	SB4155001	1	バンド	BAND	

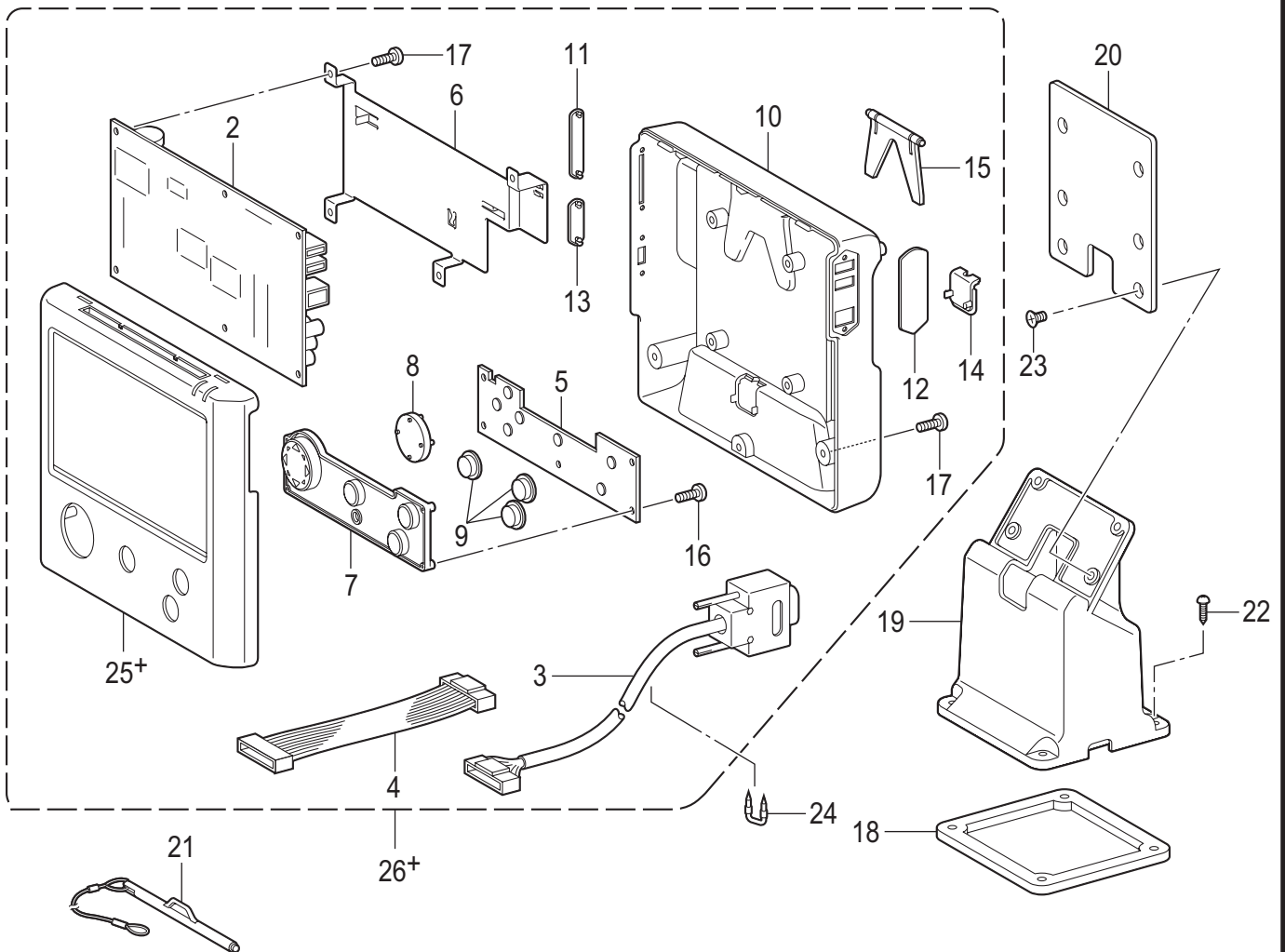
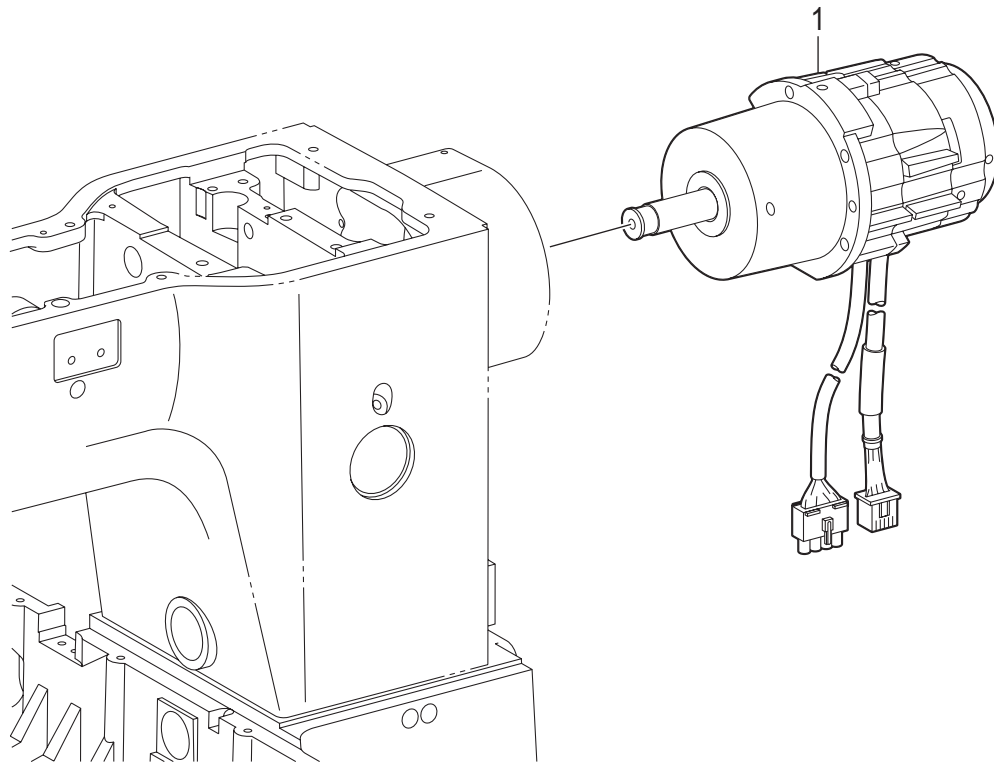

Q. モーター・液晶パネル関係 / Motor mechanism and LCD panel

REF.NO	CODE	Q'TY	品名	NAME OF PARTS	RM
1	SB0752101	1	モータ430ホキユウ	MOTOR 430 SUPPLY	
2	SB6019001	1	プログラマメインキバンクミ	PROGRAMMER MAIN PCB ASSY	
3	SB6313001	1	プログラマハーネス3100	PROGRAMMER HARNESS 3100	
4	SB6472001	1	メインキーハーネス	MN-KEY HARNESS	
5	SB6525001	1	プログラマキーキバンクミ	PROGRAMMER KEY PCB ASSY	
6	SB6538001	1	アースプレート	EARTH PLATE	
7	SB6539001	1	キーボード	KEYBOARD	
8	SB6540001	1	カーソルキー	CURSOR KEY	
9	SB6541001	3	プッシュキー	PUSH KEY	
10	SB6542001	1	リアカバークミ	REAR COVER ASSY	
11	SB6545001	1	サイドカバーSD	SIDE COVER SD	
12	SB6546001	1	サイドカバーUSB	SIDE COVER USB	
13	SB6547001	1	サイドカバーBCR	SIDE COVER BCR	
14	SB6551001	1	リアカバーフタ	REAR COVER CAP	
15	SB6552001	1	リアスタンド	REAR STAND	
16	085310816	5	バインドBタイト3X8	TAPTITE BIND B M3X6	
17	085311016	8	バインドBタイト3X10	TAPTITE BIND B M3X10	
18	SB6557001	1	クッションゴム	RUBBER CUSHON	
19	SB6554001	1	プログラマクレードル	PROGRAMMER CRADLE	
20	SB6555001	1	クレードルトリツケイタ	CRADLE MOUNTING PLATE	
21	SB6556001	1	ペンクミ	PEN ASSY	
22	0B0452006	4	+マルモク45X20	WOOD SCREW ROUND M4.5X20	
23	004400803	1	+サラコ4×8	SCREW, FLAT M4×8	
24	200190001	2	ステツプル 10×20	STAPLE 10×20	
			<輸出一般向(ロゴ無し)>	<For General export (W/O LOGO)>	
25+	SB6532001	1	フロントカバークミ	FRONT COVER ASSY	
26+	SB6581001	1	パネルプログラマクミ	PANEL PROGRAMMER ASSY	
			<輸出一般向>	<For General export>	
25+	SB6532002	1	フロントカバークミ	FRONT COVER ASSY	
26+	SB6581002	1	パネルプログラマクミ	PANEL PROGRAMMER ASSY	

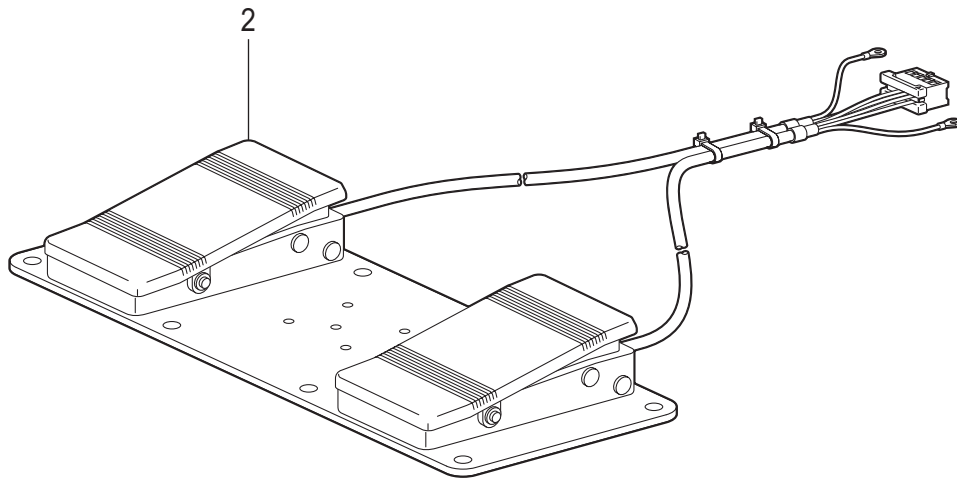
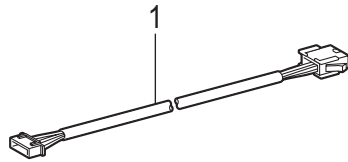

R. 踏板関係 / Foot switch pedal mechanism

REF.NO	CODE	Q'TY	品名	NAME OF PARTS	RM
1	SB1565001	1	フットSWヘンカンハーネス	CONVERSION HARNESS FOOT SW	
2	SA6038101	1	2レンフットSWクミ	2-PEDAL FOOT SW ASSY	

BAS-311HN/326H-651

T1. 付属装置関係(オプション部品) / Attachment set (Option parts)

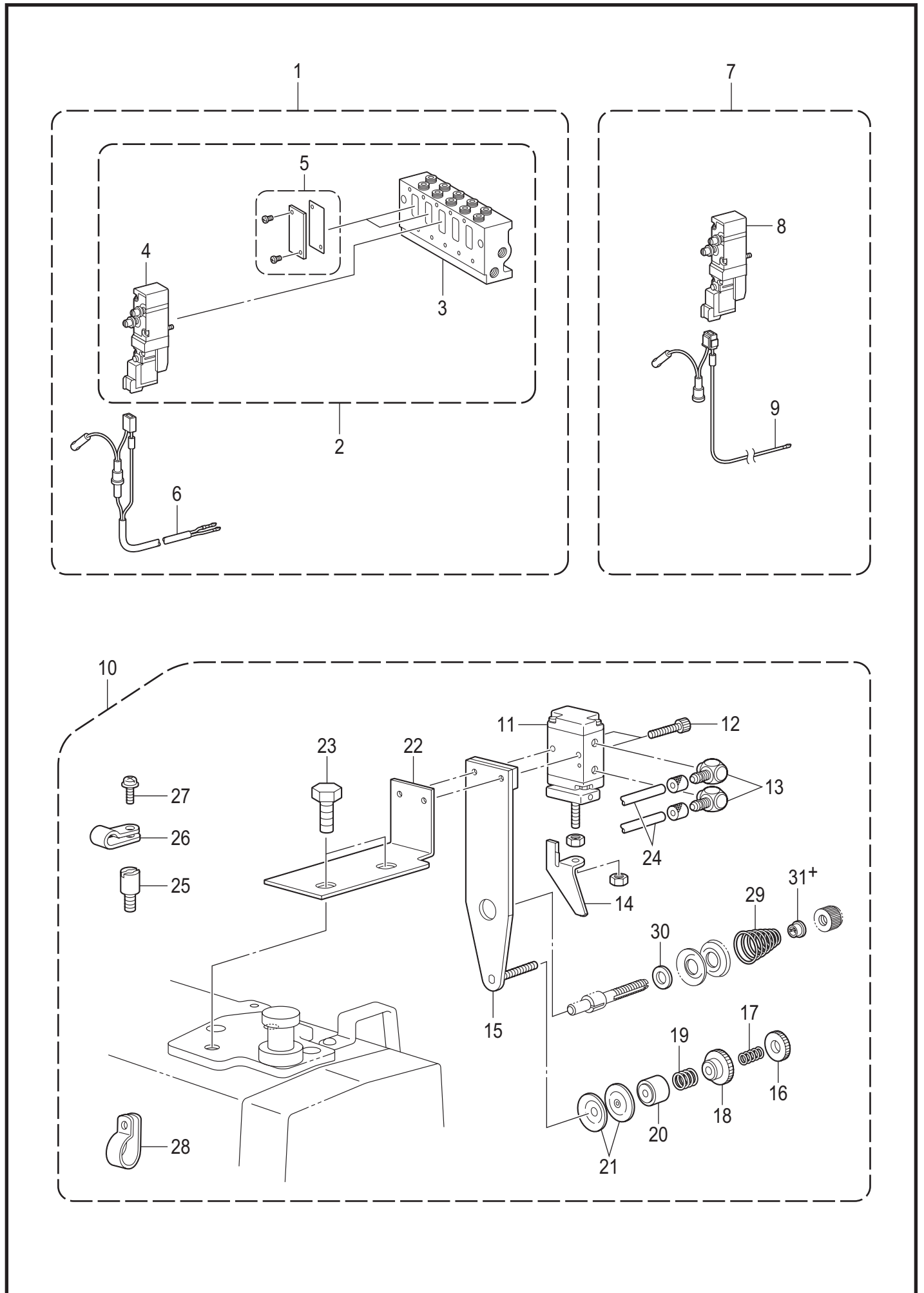

T1. 付属装置関係 (オプション部品) / Attachment set (Option parts)

REF.NO	CODE	Q'TY	品名	NAME OF PARTS	RM
1	SA7500001	1	OPマニホールド5セット	OPTION MANIFOLD 5 SET	
2	SA7501001	1	OPマニホールド5クミ	OPTION MANIFOLD 5 ASSY	
3	SA5290001	1	マニホールド5	MANIFOLD5	
4	S39116100	1	バルブVQZ2151S-5	VALVE VQZ2151S-5	
5	S53982000	2	ブランキングプレートクミ	BLANKING PLATE ASSY	
6	SA7166101	1	バルブハーネスX1クミ	VALVE HARNESS ASSY X1	
7	SA7171001	1	OPツイカバルブクミ	OPTION ADD VALVE ASSY	
8	S39116100	1	バルブVQZ2151S-5	VALVE VQZ2151S-5	
9	SA7167101	1	ツイカバルブハーネスSG	OP VALVE HARNESS SG	
10	SA7197101	1	2ダンテンションソウチ	2-STEP THREAD TENSION DEVICE	
11	S34706000	1	エア-シリンダ10X10	AIR CYLINDER, 10X10	
12	018302036	2	アナボルト3X20	BOLT SOCKET M3X20	
13	S12150000	2	ホ-スエルボM-5HL-4	TUBE ELBOW, M-5HL-4	
14	S34533001	1	サラワリツメ	COUNTERSINK CLAW	
15	S34534101	1	サブテンションダイクミ	SUB TENSION BRACKET ASSY	
16	155510001	1	イトチヨウシナツト	TENSION NUT	
17	146060000	1	ナツトオシバネ	SPRING	
18	146059001	1	プレテンションナツト	PRE-TENSION NUT	
19	146058001	1	プレテンションバネ	PRE-TENSION SPRING	
20	146206009	1	イトアンナイサラオサエ	DISC PRESSER, T-GUIDE	
21	144504001	2	イトアンナイサラ	THREAD GUIDE DISC	
22	SA7199001	1	シリンダ-トリツケイタ	SETTING BRACKET CYLINDER	
23	017081606	2	ボルト8X16	BOLT M8X16	
24	S15031010	2	エア-チューブ	AIR TUBE, 4X2.5	
25	SA7155001	2	スペ-サ	SPACER	
26	S00480000	2	コードホルダ#5	CORD HOLDER 5N	
27	0A5401006	2	+ナベザクミ4X10DB	SCREW PAN (S/P WASHER) M4X10	
28	525907000	1	コードホルダ#9	CORD HOLDER #9	
29	SA3416101	1	イトチヨウシバネLL	TENSION SPRING LL	
30	S48140002	1	ザガネ	WASHER	
31+	P.74	1	チヨウシバネウエザガネ	WASHER	

T2. 付属装置関係(オプション部品) / Attachment set (Option parts)

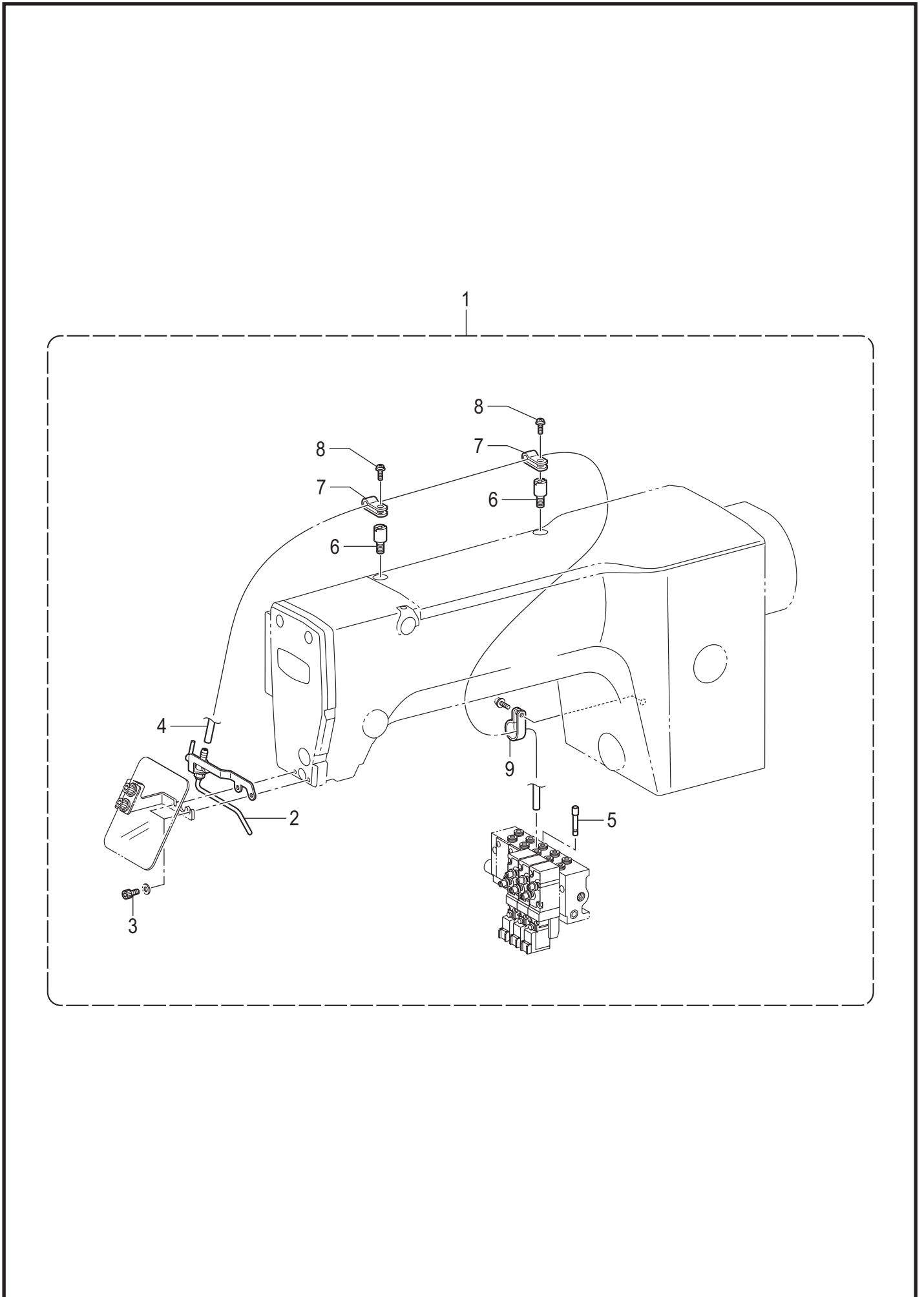

T2. 付属装置関係 (オプション部品) / Attachment set (Option parts)

REF.NO	CODE	Q'TY	品名	NAME OF PARTS	RM
1	SA5559101	1	ニードルクーラーソウチセット	NEEDLE COOLER SET	
2	S18027201	1	ニードルブロワー	NEEDLE BLOWER	
3	062400816	2	ナベコ4X8	SCREW PAN M4X8	
4	S15031010	1	エアチューブ	AIR TUBE, 4X2.5	
5	S04897000	1	プラグ4	PLUG 4	
6	SA7155001	2	スペーサ	SPACER	
7	S10243000	2	ナイロンクランプNK-3N	CORD HOLDER:NK-3N	
8	0A5401006	2	+ナベザクミ4X10DB	SCREW PAN (S/P WASHER) M4X10	
9	525907000	1	コードホルダ#9	CORD HOLDER #9	

T3. 付属装置関係(オプション部品) / Attachment set (Option parts)

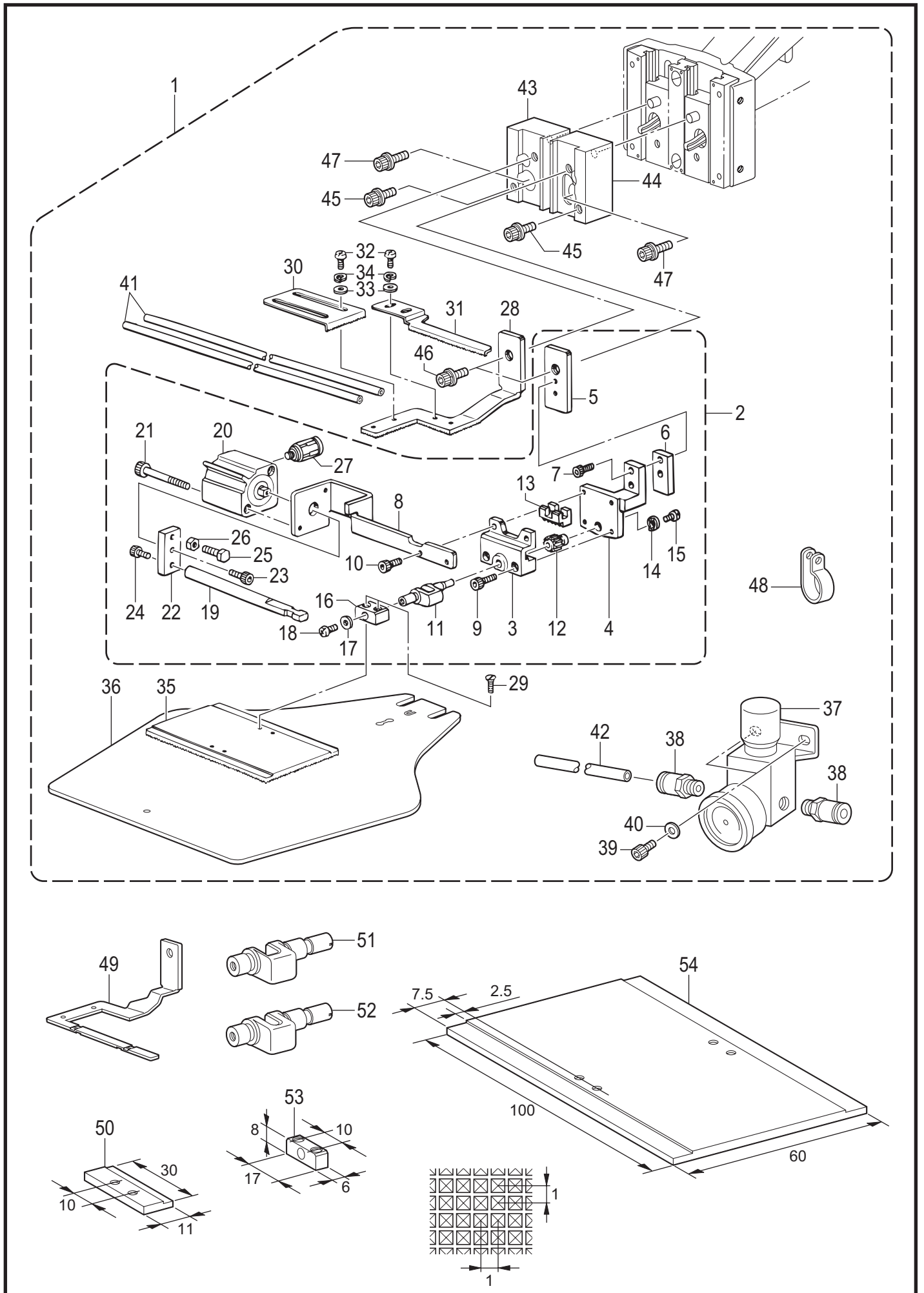

T3. 付属装置関係 (オプション部品) / Attachment set (Option parts)

REF.NO	CODE	Q'TY	品名	NAME OF PARTS	RM
1	SA7189101	1	ネームツケハンテンスウチセット	INNER CLAMPING DEVICE SET	
2	S12633309	1	オサエクランクLAクミ	WORK CLAMP CRANK ASSY LA	
3	S12634109	1	オサエクランクホルダA	WORK CLAMP CRANK HOLDER A	
4	S12635009	1	オサエクランクホルダB	WORK CLAMP CRANK HOLDER, B	
5	S12636001	1	オサエクランクホルダC	WORK CLAMP CRANK HOLDER, C	
6	S12641009	1	クランクホルダカンザ	SPACER, CRNK HOLDER	
7	S59894001	2	アナボルト437-40X12	BOLT, SOCKET SM4.37-40X12	
8	SA6373001	1	ハンテンスリンドダイ	REVERSE CYLINDER BASE	
9	018301236	2	アナボルト3X12	BOLT SOCKET M3X12	
10	018301036	2	アナボルト3X10	BOLT SOCKET M3X10	
11	S05665001	1	オサエクランクLA	WORK CLAMP CRANK, LA	
12	154235001	1	ハンテングヤ	REVERSE GEAR	
13	154236001	1	ハンテンドラック	REVERSE RACK	
14	145087001	1	ハンテングヤザガネ	WASHER	
15	149831101	1	アタマツキトメネジ3.18	SET SCREW, SM3.18	
16	154237101	1	オサエイタホルダL	WORK CLAMP PLATE HOLDER L	
17	025350132	1	ヒラザガネシヨウ3.5	WASHER PLAIN S 3.5	
18	100242003	1	シメネジ3.57	SCREW, SM3.57-40X5	
19	S12637009	1	ハンテンドッド	REVERSE ROD	
20	SA6362001	1	ハンテンスリンド	REVERSE CYLINDER	
21	S12642009	2	アナボルト3X35	BOLT SOCKET M3X35	
22	SA7193001	1	ハンテンドラックジョイント	REVERSE SHAFT JOINT	
23	018400836	1	アナボルト4X8	BOLT SOCKET M4X8	
24	018300836	1	アナボルト3X8	BOLT SOCKET M3X8	
25	017501216	1	ボルト5X12	BOLT M5X12	
26	021500216	1	2シュナット5	NUT 2 M5	
27	S18415101	2	ハーフユニオンQ4M5	HALF UNION :Q4M5	
28	S12643001	1	ソトオサエアシ312-1	OUTER WORK CLAMP, 312-1	
29	117291002	2	サラネジ3.18	SCREW, FLAT SM3.18	
30	154252001	1	イチギメイタL	POSITIONING PLATE, L	
31	154253001	1	イチギメイタR	POSITIONING PLATE, R	
32	062670512	4	ナベコ357-40X5	SCREW PAN SM3.57-40X5	
33	SB2456001	4	ヒラザガネダイ3.5	WASHER PLAIN 3.5	
34	028350242	4	バネザガネ2-3.5	WASHER SPRING 2-3.5	
35	154256101	1	オサエイタブランクA	WORK CLAMP PLATE BLANK, A	
36	SA7460001	1	オクリイタブランク311G	FEED PLATE BLANK 311G	
37	S12165000	1	レギュレーター	REGULATOR	
38	S04905000	2	ハーフユニオン	HALF UNION	
39	018400636	2	アナボルト4X6	BOLT SOCKET M4X6	
40	SB3848001	2	ヒラザガネチューブ4	WASHER_PLAIN_M_4	
41	S03803000	2	ナイロンチューブ	AIR TUBE	
42	S28741000	1	エアチューブ	AIR TUBE, 4 L=300	
43	SA6617001	1	オサエクランクスペーサL	WORK CLAMP CRANK SPACER L	
44	SA6616001	1	オサエクランクスペーサR	WORK CLAMP CRANK SPACER R	
45	S55484001	2	アナボルトザクミ5X10	BOLT SOCKET (S/P WASHER)M5X10	
46	S55484001	2	アナボルトザクミ5X10	BOLT SOCKET (S/P WASHER)M5X10	
47	S55485001	2	アナボルトザクミ5X12	BOLT SOCKET (S/P WASHER)M5X12	
48	552907000	1	コードホルダ#10	CORD HOLDER #10	
49	S12644001	1	ソトオサエアシ312-2	OUTER WORK CLAMP, 312-2	
50	S10542001	1	ナカオサエLL	INNER CLAMP, LL	
51	S04516001	1	オサエクランクSS	WORK CLAMP CRANK, SS	
52	154297001	1	オサエクランクS	WORK CLAMP CRANK, S	
53	154291101	1	オサエイタホルダS	WORK CLAMP PLATE HOLDER S	
54	156492101	1	オサエイタブランク7.5-A	WORK CLAMP PLATE BLANK 7.5-A	

Z. 付属品関係 / Accessories

<オプション部品 / Option parts >

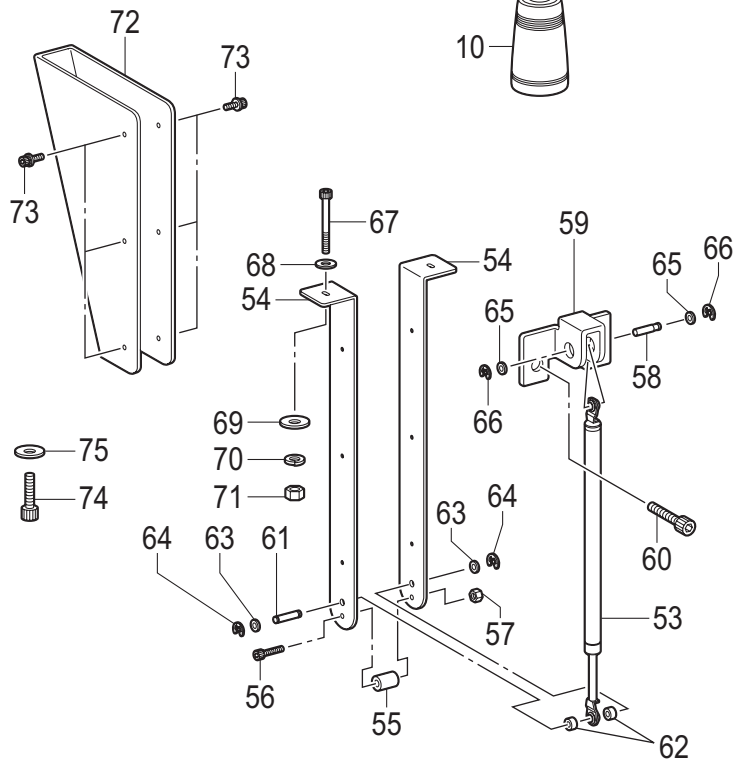
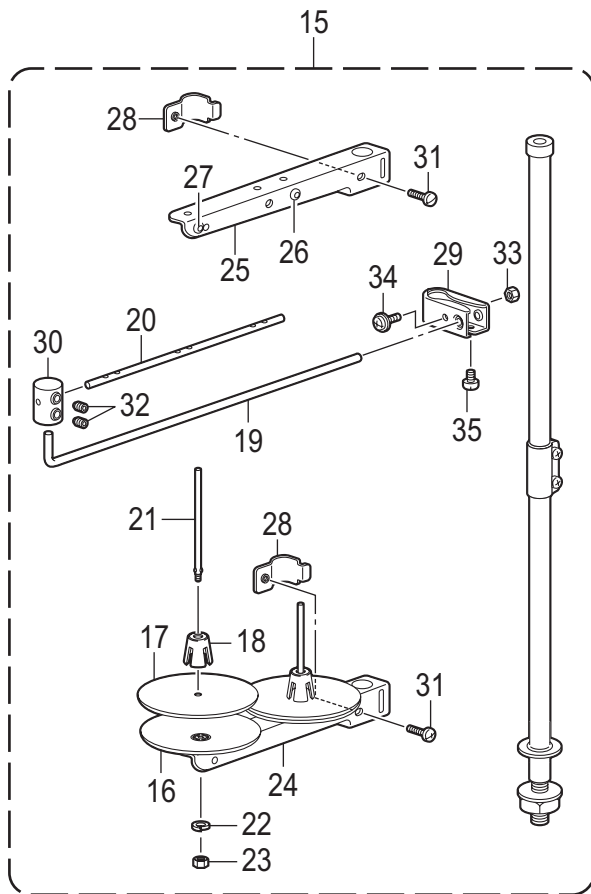
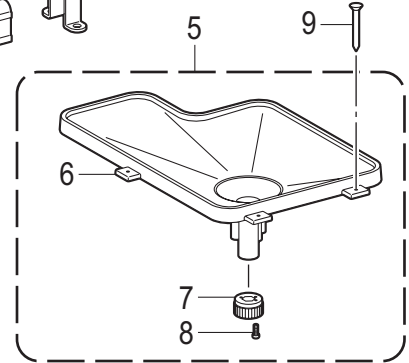
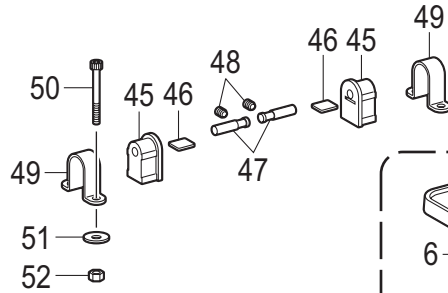
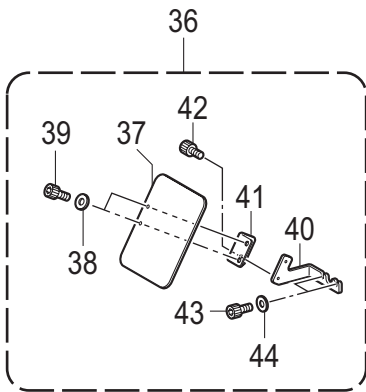
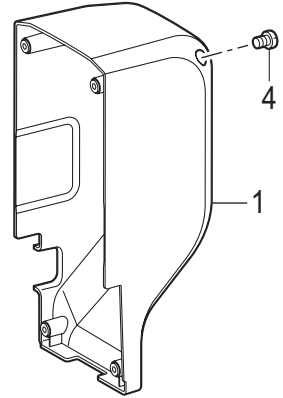
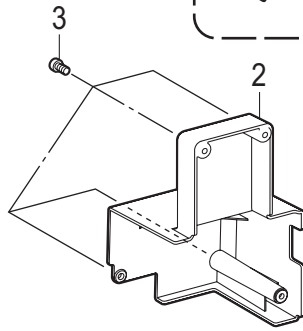
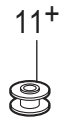
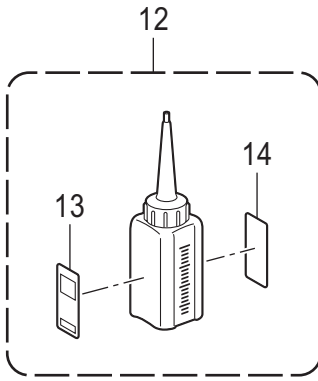
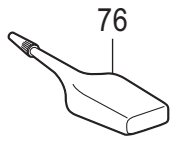

BAS-311HN/326H-910

Z. 付属品関係 / Accessories

REF.NO	CODE	Q'TY	品名	NAME OF PARTS	RM
1	SB4412001	1	リアカバー	REAR COVER	
2	SB4403001	1	サイドカバー	SIDE COVER	
3	062501216	4	ナベコ5X12	SCREW PAN M5X12	
4	062501216	4	ナベコ5X12	SCREW PAN M5X12	
5	SB4515001	1	オイルパンクミ	OIL PAN ASSY	
6	SB4383001	1	オイルパン	OIL PAN	
7	SB4168001	1	ハイユキヤツプ	DUST OILER	
8	037301215	2	Vナベタツピン3X12	TAPPING SCREW PAN V M3X12	
9	109714000	6	クギ	NAIL	
10	114486002	1	ポリオイラータイ	OILER	
11+	P.73	1	ボビンLAN	BOBBIN LAN	
12	SA8239202	1	オイルタンククミ	OIL TANK ASSY	
13	SB1270001	1	オイルケイコクラベル エイブン	OIL WARNING LABEL EN	
14	SB1271001	1	オイルケイコクラベル ワブン	OIL WARNING LABEL JP	
15	S40574409	1	イトタテダイクミ2DTHF	COTTON STAND ASSY 2DTHF	
16	S51283001	2	ウケザラ	SPOOL STAND BASE	
17	150182000	2	スプ-ルマット	SPOOL MAT	
18	S51282101	2	スプ-ルクツシヨン	SPOOL CUSHION	
19	S04109001	1	イトアンナイササエボウ	THREAD GUIDE SUPPORT BAR	
20	142997001	1	イトアンナイ3	THREAD GUIDE, 3	
21	150179002	2	スプ-ルジクB	SPOOL SHAFT B	
22	028050243	2	バネザガネ2-5	WASHER, SPRING 2-5	
23	021500203	2	2シュナツト5	NUT, 2 M5	
24	SA6607001	1	スプ-ルホルダ-2	SPOOL HOLDER 2	
25	SA6607001	1	スプ-ルホルダ-2	SPOOL HOLDER 2	
26	150183000	2	イトカケハンガーダイ	THREAD HANGER BASE	
27	142990001	2	スレツドブツシュ	THREAD BUSH	
28	SA6609001	2	スプ-ルホルダ-ササエ	SPOOL HOLDER SUPPORTER	
29	SA6615001	1	イトアンナイホルダ-	THREAD GUIDE HOLDER	
30	138843201	1	ササエボウツギテ	JOINT	
31	062061603	2	ナベコ6X16	SCREW PAN M6X16	
32	014060632	2	アナクボミ6X6	SET SCREW SOCKET (CP) M6X6	
33	021500203	1	2シュナツト5	NUT, 2 M5	
34	S37037001	1	ナベコヒラザ5X32	SCREW PAN (S/P WASHER) M5X32	
35	062061003	1	ナベコ6X10	SCREW PAN M6X10	
36	SB0557301	1	アイガードセットE	EYE GUARD SET E	
37	SB4169001	1	アイガード	EYE GUARD	
38	026030233	2	ヒラザガネミガキ3	WASHER PLAIN M 3	
39	018300636	2	アナボルト3X6	BOLT SOCKET M3X6	
40	SB0559101	1	アイガードホルダ-A	EYE GUARD HOLDER A	
41	SB0556001	1	アイガードホルダ-B	EYE GUARD HOLDER B	
42	018400836	1	アナボルト4X8	BOLT SOCKET M4X8	
43	018400836	2	アナボルト4X8	BOLT SOCKET M4X8	
44	026040136	2	ヒラザガネコガタ4	WASHER PLAIN S 4	
45	SA3395001	2	トウブヒンジゴム	RUBBER CUSHION	
46	SA3392101	2	スペ-サ	SPACER	
47	SA3384101	2	トウブササエピン	PIN	
48	012060636	2	アナヒラ6X6	SET SCREW SOCKET (FT) M6X6	
49	SA3385001	2	トウブヒンジウケ	HINGE HOLDER	
50	018066036	4	アナボルト6X60	BOLT SOCKET M6X60	
51	213650001	4	ワ2.3X8.5X38ST	WASHER 2.3X8.5X38ST	
52	021060106	4	1シュナツト6	NUT 1 M6	
53	SB0468001	1	ガススプリングクミ311G	SHOCK ABSORBER GAS ASSY 311G	
54	SA4846002	2	ガススプリングササエ	HOLDER ABSORBER	
55	SA5251001	1	スペ-サ	SPACER	
56	018064031	1	アナボルト6X40	BOLT SOCKET M6X40	
57	021060106	1	1シュナツト6	NUT 1 M6	
58	SB4517001	1	ガススプリングジクU	SHAFT U	
59	SB4516001	1	ガススプリングトリツケイタ	ABSORBER SETTING PLATE	
60	S42446001	2	アナボルトザクミ6X14	BOLT SOCKET (S/P WASHER)M6X14	
61	S17974101	1	ガススプリングジクD	SHAFT D	

BAS-311HN/326H-910

Z. 付属品関係 / Accessories



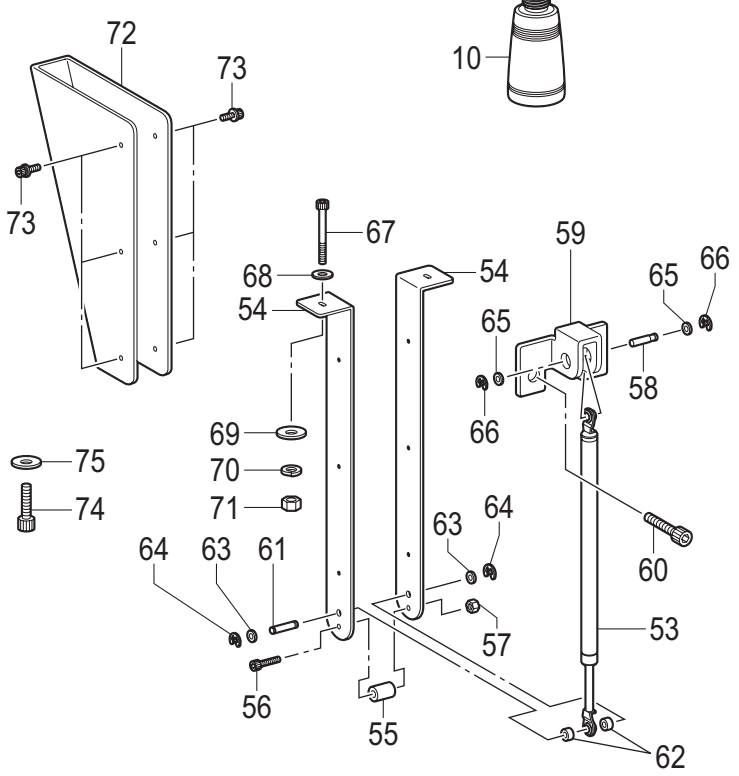
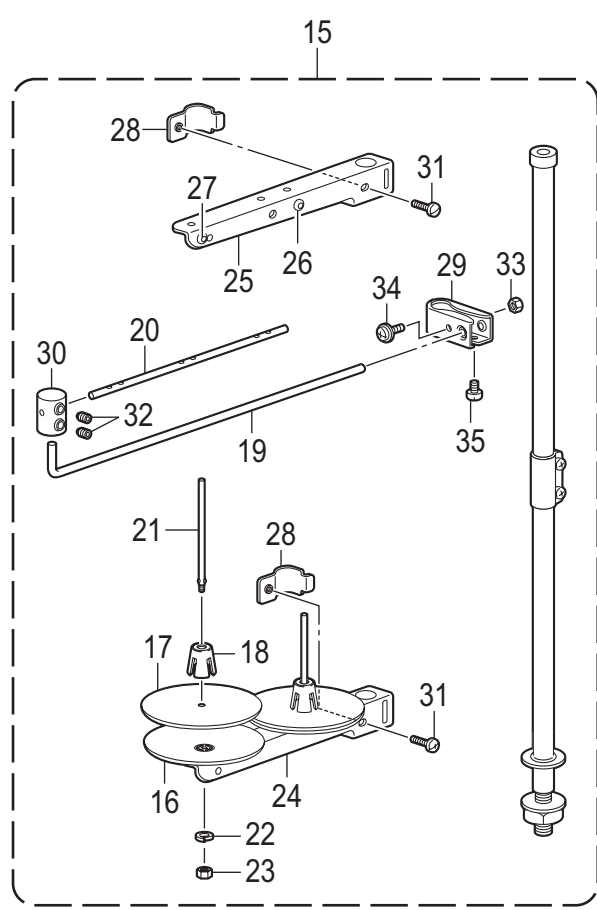
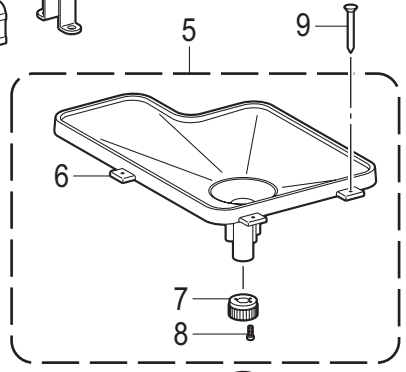
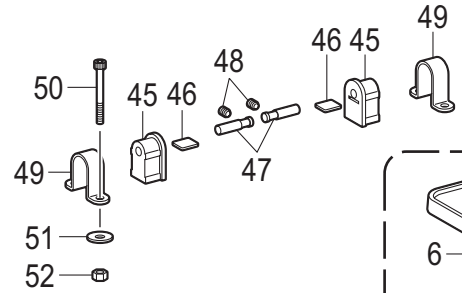
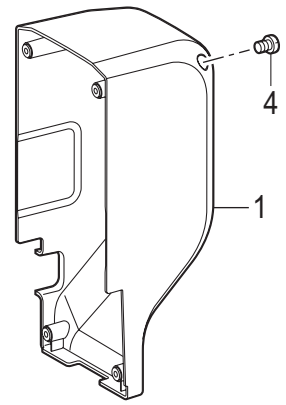
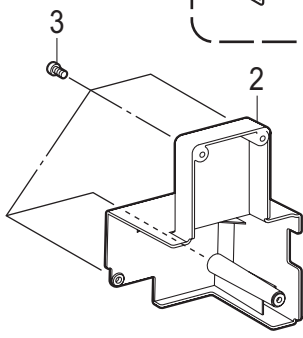
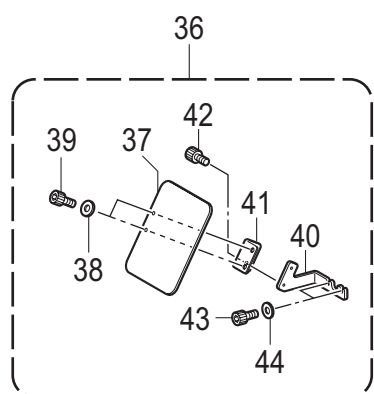
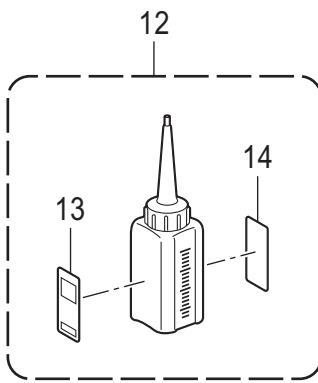
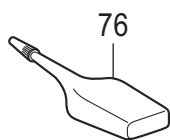



< オプション部品 / Option parts >

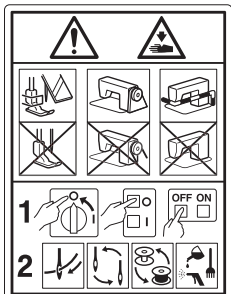

Z. 付属品関係 / Accessories

REF.NO	CODE	Q'TY	品名	NAME OF PARTS	RM
62	S17975200	2	GSジクカラ-	SHAFT COLLAR GAS	
63	SB2356001	2	ヒラザガネシヨウ8	WASHER PLAIN S 8	
64	048060342	2	トメワE6	RETAINING RING E6	
65	SB2356001	2	ヒラザガネシヨウ8	WASHER PLAIN S 8	
66	048060342	2	トメワE6	RETAINING RING E6	
67	018066036	2	アナボルト6X60	BOLT SOCKET M6X60	
68	025060236	2	ヒラザガネチュウ6	WASHER PLAIN M 6	
69	213650001	2	ワ2.3X8.5X38ST	WASHER 2.3X8.5X38ST	
70	028060246	2	バネザガネ2-6	WASHER SPRING 2-6	
71	021060106	2	1シュナット6	NUT 1 M6	
72	SA6261002	1	ガススプリングササエカバー	HOLDER ABSORBER COVER	
73	S55479001	6	アナボルトザクミ4X8	BOLT SOCKET (S/P WASHER) M4X8	
74	S21728001	2	ボルト6X80	BOLT M6X80	
75	213650001	2	ワ2.3X8.5X38ST	WASHER 2.3X8.5X38ST	
			<オプション部品>	<Option parts>	
76	S06706001	1	シリコンオイル	SILICONE OIL	







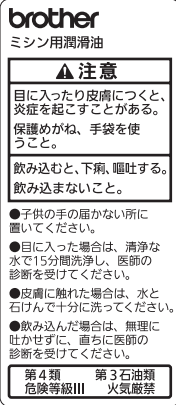
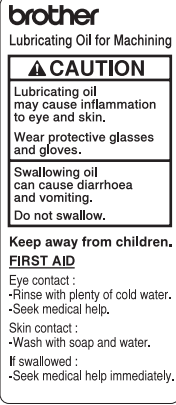



Wa. 警告ラベル / Warning labels

警告ラベル / Warning labels	品名 / Name of parts	Size(mm)	Code
	<p>ラベル感電6ヶ国 Label electrical shock 36 X 150</p>	36 X 150	SA9725-001
	<p>ラベル感電 25 X 28 Label electrical shock 25 X 28</p>	L=28.4	SA9914-001
	<p>操作注意ラベル Label caution</p>	56 X 43	SA9826-001
	<p>ワーニングマーク Injury mark</p>	L=16	SA9957-001
	<p>ワーニングマーク Injury mark</p>	L=25	SA9957-002
	<p>アースマーク Label, grounding</p>	φ 12	S37060-001
	<p>PE マーク Label, PE</p>	7.5 X 12.5	S37059-001
	<p>マークチュウイ 30 X 40 Mark attention 30 X 40</p>	30 X 40	SA4224-001







Wa. 警告ラベル / Warning labels

警告ラベル / Warning labels	品名 / Name of parts	Size(mm)	Code
	<p>オイル警告ラベル和文 Oil warning label JP</p>	<p>68 X 30</p>	<p>SB1271-001</p>
	<p>オイル警告ラベル英文 Oil warning label EN</p>	<p>68 X 30</p>	<p>SB1270-001</p>



Sp. 仕様別部品一覧表 / Different parts list

品名 Part name	仕様 Spec.	-03S,-03A	-05S,-05A	-07A
		中厚物 Medium-weight materials	厚物 Heavy-weight materials	シートベルト Seatbelt
(J-66) 針穴板 Needle hole plate 		(φ2.2) SA5221-001	(φ2.4) SA3336-101	(φ3.0) SA5222-101
(J-63) 固定刃 Fixed knife 		SA7944-101 < FL >		SB0623-001 < FLL >
(E-41) ボビンケース組 Bobbin case assy 		S59221-301 < LC >		S59222-301 < LD >
(E-42) ボビンケース 調子ばね Tension spring 		S48664-001 < AN >		S16075-101 < B >
(E-43) ボビンケース ばねねじ Screw 		S16492-101		
(E-44) 空転防止ばね Anti-spin spring 		S15667-001		
(E-45) (Z-11) ボビン Bobbin 		S44633-001 < LAN >		S15666-001 < LB >
(E-36) ドライバー Driver 		SA6448-301 < E >		S55215-101 < HR >
(E-40) 中がま箱組 Shuttle hook assy, w/box 		SA2173-301 < LF >	SA8197-101 < LH >	SA8197-101 < LH >
(E-39) 大がま Shuttle race base 		152682-201 < A >	152686-201 < B >	152686-201 < B >

Sp. 仕様別部品一覧表 / Different parts list

品名 Part name	仕様 Spec.	-03S,-03A 中厚物 Medium-weight materials	-05S,-05A 厚物 Heavy-weight materials	-07A シートベルト Seatbelt
	(G-47) 糸調子ばね Tension spring 		—	—
(G-24) 糸取りばね Thread take-up spring 		SA6193-001		144588-401
(G-22) 副調子ばね Sub tension spring 		SA4146-101		SA3416-101
(G-23)(T1-31) 調子ばね上ザガネ Washer 		—		S20681-000
(G-19) 針棒糸案内 Needle bar thread guide  A  B		SA3257-101 < A >		SA4815-201 < B >
(D1-56) 押え足 Presser foot 		S42843-001 < A >		S42844-001 < B >

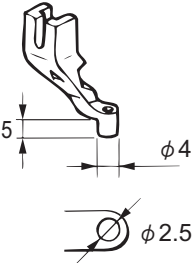
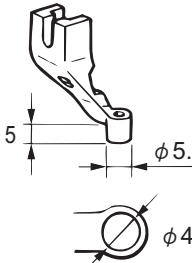
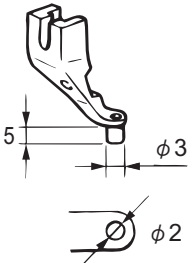
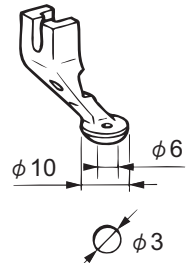
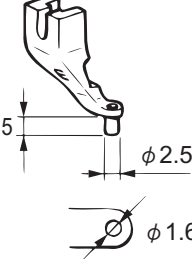
Ga. ゲージ部品一覧表 / Gauge parts list

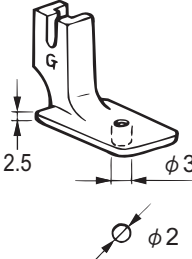
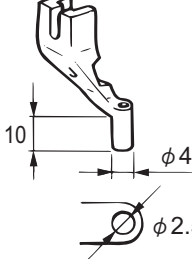
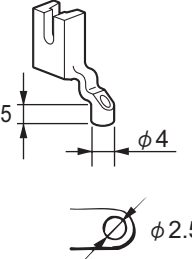
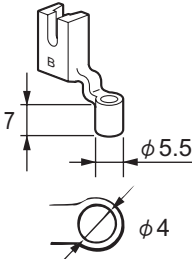
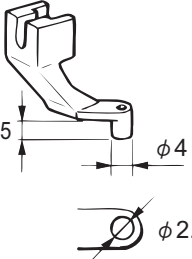
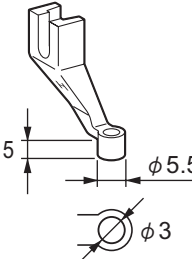
押え足 / Presser foot			
A / S42843-001 *	B / S42844-001	C / S42845-001	D / S42846-001
			
E / S42847-001	F / 157237-001	G / 158592-001	J / S42848-001
			
A-CUT / S40214-001	B-L / S49448-001	XA / S42849-101	H / SA4811-001
			

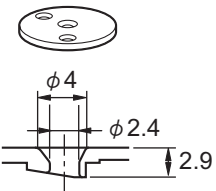
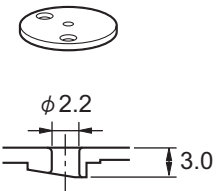
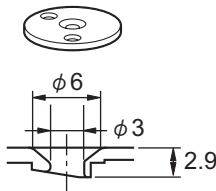
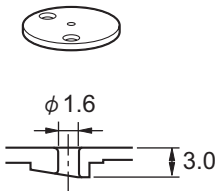
針穴板 / Needle hole plate			
2.4 C0.4 / SA3336-101 *	2.2 / SA5221-001 *	3.0 C1.5 / SA5222-101 *	1.6 / SA7191-001
			

* 印の部品は、標準部品です。

The * symbol is for Standard parts.

CODE	REF.NO	Page	CODE	REF.NO	Page	CODE	REF.NO	Page	CODE	REF.NO	Page
004300513	A -24	2	012500536	J -50	40	018401036	F -50	32	028030246	C2 -32	8
004400803	Q -23	58	012501031	C6 -43	16	018401236	C5 -29	14		J -71	42
012060536	B -37	4		C7 -32	18		H -13	38	028040246	C1 -39	6
	C5 -13	14		C7 -37	18	018401636	B -27	4		C2 -45	8
	C5 -25	14		C8 -31	20	018500836	C6 -34	16		C7 -15	18
	C6 -16	16		C8 -36	20	018501036	C1 -3	6		C8 -13	20
	C6 -32	16	014060632	Z -32	68		C3 -9	10		J -6	40
	C7 -22	18	016061031	D2 -32	26		C4 -10	12		L1 -3	46
	C8 -20	20		D2 -36	26		C5 -17	14		L2 -3	48
	D1 -54	24		D3 -14	28		C5 -30	14	028050243	Z -22	68
	E -6	30	017061213	D1 -12	24		D2 -21	26	028050246	C3 -10	10
012060636	B -24	4	017061612	D1 -44	24		D3 -3	28		C4 -11	12
	C1 -18	6	017065002	D1 -45	24	018501232	E -37	30		C6 -36	16
	C1 -22	6	017081606	T1 -23	62	018501636	B -3	4		C6 -50	16
	C1 -33	6	017400802	L1 -2	46		B -36	4		C7 -42	18
	C2 -18	8		L2 -2	48	018503036	N -12	54		C8 -41	20
	C2 -19	8	017401015	L1 -5	46	021060106	D1 -10	24		N -11	54
	C2 -22	8	017401415	L2 -5	48		J -34	40	028060246	Z -70	70
	C6 -12	16	017501216	T3 -25	66		Z -52	68	028080246	M1 -9	50
	C6 -21	16	017501616	C6 -48	16		Z -57	68	028350242	T3 -34	66
	C6 -28	16		C7 -40	18		Z -71	70	032422003	N -19	54
	C7 -5	18	018061236	D2 -58	26	021060306	D1 -41	24	037301215	Z -8	68
	C7 -18	18		D3 -27	28		J -23	40	047402042	B -45	4
	C8 -3	20	018061636	J -53	40		J -31	40	048030342	K -20	44
	C8 -16	20	018062536	C2 -4	8		J -39	40	048040142	C6 -8	16
	D1 -14	24	018063036	C1 -19	6		J -43	40	048040342	J -19	40
	D1 -24	24	018064031	Z -56	68		J -47	40		K -13	44
	D1 -30	24	018066036	Z -50	68		J -52	40	048050142	C7 -7	18
	D1 -36	24		Z -67	70	021080206	M1 -10	50		C8 -5	20
	D2 -11	26	018300536	C2 -3	8	021300103	A -28	2	048050342	H -10	38
	D2 -14	26		C2 -10	8		C2 -9	8	048060142	C7 -10	18
	D2 -25	26	018300636	Z -39	68		C2 -36	8		C8 -8	20
	D2 -33	26	018300836	T3 -24	66	021400106	C6 -53	16		G -37	36
	D2 -37	26	018301036	C2 -2	8		C7 -47	18	048060342	Z -64	70
	D2 -41	26		C2 -6	8		C8 -47	20		Z -66	70
	D2 -57	26		C2 -34	8	021400216	C1 -40	6	048070342	E -38	30
	D3 -7	28		C2 -37	8		C2 -46	8	048080142	C6 -13	16
	D3 -15	28		G -34	36		C3 -4	10		C6 -29	16
	D3 -19	28		T3 -10	66		C4 -4	12		C7 -19	18
	D3 -32	28	018301236	C2 -31	8		C6 -25	16		C8 -17	20
	D3 -33	28		T3 -9	66		J -5	40		D1 -29	24
	E -9	30	018302036	T1 -12	62	021400306	G -17	36	048080342	D2 -13	26
	E -12	30	018400636	D2 -39	26		L1 -6	46	048100142	C1 -26	6
	E -35	30		D3 -17	28		L2 -6	48		C2 -26	8
	G -51	36		F -11	32	021500203	Z -23	68		C6 -5	16
	J -42	40		T3 -39	66		Z -33	68		D2 -28	26
	Z -48	68	018400836	C2 -13	8	021500216	C6 -44	16		D3 -10	28
012400436	D1 -25	24		C5 -5	14		C7 -33	18	048280142	B -43	4
	D1 -31	24		C5 -7	14		C7 -38	18	060400516	K -22	44
	G -36	36		C7 -14	18		C8 -32	20		L1 -15	46
	H -17	38		C8 -12	20		C8 -37	20		L2 -17	48
	J -9	40		D1 -47	24		T3 -26	66	062060816	F -30	32
012400636	C1 -4	6		D2 -3	26	025040236	C9 -6	22	062061003	Z -35	68
012500536	A -48	2		D3 -26	28	025040332	A -34	2	062061016	A -21	2
	B -21	4		K -10	44		L1 -7	46		F -4	32
	B -34	4		T3 -23	66		L2 -7	48		H -33	38
	B -35	4		Z -42	68	025060236	Z -68	70	062061603	Z -31	68
	D2 -46	26		Z -43	68	025080336	M1 -8	50	062300416	C1 -49	6
	D2 -51	26	018401036	C5 -11	14	025350132	T3 -17	66		C2 -55	8
	D3 -24	28		C5 -16	14	026030233	Z -38	68		D1 -20	24
	E -47	30		C5 -23	14	026040136	F -33	32		J -64	42
	G -3	36		D2 -23	26		Z -44	68	062300506	A -27	2
	H -3	38		D3 -5	28	028030246	C2 -8	8	062300616	E -22	30

索引 / Index

CODE	REF.NO	Page	CODE	REF.NO	Page	CODE	REF.NO	Page	CODE	REF.NO	Page
062300616	K - 8	44	102630021	D2 - 9	26	150182000	Z - 17	68	S00705001	J - 62	42
062300816	P - 8	56	104449001	A - 4	2	150183000	Z - 26	68	S02429201	E - 17	30
062350616	H - 8	38		A - 5	2	151439102	D1 - 58	24	S02652021	J - 11	40
062400416	D2 - 6	26		A - 6	2	152682201	Sp	73	S03677001	K - 23	44
062400616	D1 - 6	24		A - 38	2	152684101	E - 20	30	S03803000	T3 - 41	66
	D2 - 29	26	104450101	A - 41	2	152686201	Sp	73	S03816001	M1 - 17	50
	D2 - 54	26	104567101	F - 19	32	152744001	D2 - 8	26		M2 - 3	52
	D2 - 56	26	104821001	A - 7	2	152881101	G - 50	36	S04109001	Z - 19	68
	D3 - 11	28		A - 46	2	152883000	G - 52	36	S04516001	T3 - 51	66
	F - 6	32		A - 47	2	152884001	G - 53	36	S04897000	T2 - 5	64
	F - 13	32		D3 - 29	28	152936001	H - 6	38	S04905000	T3 - 38	66
	F - 32	32	107606101	Sp	74	152937001	H - 7	38	S05665001	T3 - 11	66
062400816	B - 22	4	108802001	E - 49	30	153274001	N - 9	54	S06706001	Z - 76	70
	B - 33	4	109714000	Z - 9	68	154235001	T3 - 12	66	S07350002	A - 13	2
	C1 - 13	6	109763022	D2 - 45	26	154236001	T3 - 13	66		G - 6	36
	T2 - 3	64		D2 - 50	26	154237101	T3 - 16	66	S07459100	F - 16	32
062401016	A - 9	2		D3 - 23	28	154252001	T3 - 30	66	S08003000	F - 59	32
	A - 33	2		G - 38	36	154253001	T3 - 31	66	S09043000	F - 24	32
062401216	C1 - 50	6	110367001	B - 18	4	154256101	T3 - 35	66	S09228000	N - 6	54
	C2 - 56	8		C6 - 14	16	154291101	T3 - 53	66	S10112101	D1 - 51	24
062500616	G - 9	36		C6 - 30	16	154297001	T3 - 52	66	S10243000	T2 - 7	64
	G - 11	36		C7 - 20	18	154596000	J - 32	40	S10268001	H - 24	38
	G - 13	36		C8 - 18	20	154599000	J - 10	40	S10438001	H - 18	38
	H - 27	38	110735022	K - 19	44	155510001	T1 - 16	62	S10470201	K - 21	44
062500816	L1 - 11	46	111466121	D1 - 55	24	155559021	H - 9	38	S10542001	T3 - 50	66
	L2 - 11	48	114486002	Z - 10	68	156492101	T3 - 54	66	S12150000	T1 - 13	62
062501216	A - 30	2	117291002	T3 - 29	66	157237001	Ga	75	S12165000	T3 - 37	66
	Z - 3	68	117608001	A - 2	2	158592001	Ga	75	S12441001	G - 46	36
	Z - 4	68	118208001	D2 - 15	26	159150000	A - 36	2		H - 32	38
062670412	G - 54	36	118550001	D3 - 30	28	159163000	A - 35	2	S12633309	T3 - 2	66
062670512	T3 - 32	66	120265002	A - 12	2		D3 - 28	28	S12634109	T3 - 3	66
070696800	D2 - 44	26		G - 5	36	159805001	G - 45	36	S12635009	T3 - 4	66
	D2 - 49	26	120448001	H - 22	38	200190001	M1 - 18	50	S12636001	T3 - 5	66
	D3 - 22	28	138843201	Z - 30	68		M2 - 4	52	S12637009	T3 - 19	66
081003670	E - 14	30	141362001	D1 - 34	24		Q - 24	58	S12641009	T3 - 6	66
	E - 51	30	142211001	B - 25	4	213650001	Z - 51	68	S12642009	T3 - 21	66
085310816	Q - 16	58	142274101	F - 53	32		Z - 69	70	S12643001	T3 - 28	66
085311016	Q - 17	58	142990001	Z - 27	68		Z - 75	70	S12644001	T3 - 49	66
0A4300806	K - 24	44	142997001	Z - 20	68	218859001	P - 21	56	S12699001	G - 49	36
0A5301605	P - 10	56	144458001	B - 29	4	228475000	N - 23	54	S13399001	D1 - 57	24
0A5401006	F - 38	32	144504001	T1 - 21	62	231071001	J - 27	40	S15031010	T1 - 24	62
	F - 39	32	144588401	Sp	74	402887001	E - 21	30		T2 - 4	64
	F - 45	32	145087001	T3 - 14	66	525567000	F - 37	32	S15666001	Sp	73
	F - 46	32	145446001	G - 15	36		P - 1	56	S15667001	Sp	73
	F - 47	32		G - 32	36	525664000	F - 40	32	S16075101	Sp	73
	N - 22	54		G - 44	36	525907000	T1 - 28	62	S16492101	Sp	73
	P - 2	56	145446002	H - 29	38		T2 - 9	64	S17974101	Z - 61	68
	P - 4	56	145465001	B - 23	4	552907000	P - 5	56	S17975200	Z - 62	70
	P - 6	56	145547021	F - 31	32		T3 - 48	66	S18027201	T2 - 2	64
	P - 12	56	146058001	T1 - 19	62	BMP3010-0000000-2ST1			S18415101	T3 - 27	66
	P - 16	56	146059001	T1 - 18	62		M2 - 5+	52	S20164001	A - 39	2
	P - 18	56	146060000	T1 - 17	62	BMP3010-0000000-3ST4			S20356001	D2 - 12	26
	P - 20	56	146206009	T1 - 20	62		M2 - 6+	52		D2 - 52	26
	T1 - 27	62	146288021	K - 25	44	BMP3010-0000000-4ST4			S20681000	Sp	74
	T2 - 8	64	146354002	C3 - 11	10		M2 - 6+	52	S21728001	Z - 74	70
0B0452006	Q - 22	58		C4 - 12	12	BMP3010-0000001-3S00			S23337001	A - 37	2
100136001	G - 21	36	148847001	N - 20	54		M2 - 2+	52	S23418001	C9 - 3	22
100242003	T3 - 18	66	149097000	K - 17	44	BMP3010-0000001-3ST4				C9 - 5	22
100360003	J - 67	42	149287000	N - 21	54		M2 - 6+	52	S23418002	H - 15	38
100401022	H - 30	38	149547000	P - 3	56	J00353001	M1 - 13	50	S23651001	B - 8	4
100402004	G - 42	36	149796001	N - 24	54	J04417001	M1 - 3	50		B - 11	4
100645004	C7 - 16	18	149831101	T3 - 15	66	S00470000	P - 19	56		B - 14	4
	C8 - 14	20	150179002	Z - 21	68	S00480000	T1 - 26	62		B - 17	4

CODE	REF.NO	Page	CODE	REF.NO	Page	CODE	REF.NO	Page	CODE	REF.NO	Page
S23651001	B - 39	4	S48664001	Sp	73	SA3231001	C7 - 21	18	SA4131001	J - 1	40
	D1 - 5	24	S49448001	Ga	75		C8 - 19	20	SA4146101	Sp	74
	D1 - 15	24	S49957000	F - 34	32		E - 5	30	SA4171001	H - 5	38
	E - 8	30	S49982000	F - 25	32	SA3233101	E - 7	30	SA4172001	B - 4	4
	J - 2	40	S49992000	F - 20	32	SA3238401	E - 13	30	SA4173001	B - 4	4
	J - 26	40	S50359001	F - 51	32		E - 50	30	SA4174001	B - 4	4
S23849101	C7 - 24	18	S50527000	F - 64	34	SA3241001	E - 19	30	SA4175001	B - 4	4
	C8 - 22	20	S50547000	F - 62	34	SA3242001	E - 31	30	SA4177001	B - 10	4
S25235001	B - 15	4	S50557000	E - 27	30	SA3244001	F - 1	32	SA4178001	B - 13	4
S25279101	K - 15	44	S51282101	Z - 18	68	SA3246001	F - 27	32	SA4179001	B - 6	4
S25310101	D1 - 37	24	S51283001	Z - 16	68	SA3254001	G - 41	36	SA4180001	B - 7	4
	J - 68	42	S53982000	T1 - 5	62	SA3255001	G - 43	36	SA4197101	C5 - 24	14
S25454021	K - 14	44	S55215101	Sp	73	SA3256001	G - 14	36	SA4199001	E - 18	30
S25456021	K - 5	44	S55479001	Z - 73	70	SA3257101	Sp	74	SA4224001	C5 - 18	14
S25475101	J - 33	40	S55482001	C6 - 38	16	SA3258001	G - 20	36		D2 - 59	26
S28741000	T3 - 42	66		C7 - 26	18	SA3264101	A - 25	2		D3 - 34	28
S31032002	G - 47	36		C8 - 24	20	SA3274101	E - 33	30		Wa	71
	H - 31	38	S55484001	C5 - 3	14	SA3280001	F - 28	32	SA4302001	D1 - 9	24
S32465101	J - 22	40		J - 12	40	SA3283101	E - 46	30	SA4333001	G - 8	36
	J - 38	40		T3 - 45	66	SA3290001	H - 2	38	SA4354001	J - 57	40
S34533001	T1 - 14	62		T3 - 46	66	SA3291001	H - 4	38	SA4518001	J - 60	40
S34534101	T1 - 15	62	S55485001	C5 - 33	14	SA3293001	H - 11	38	SA4519001	J - 61	40
S34706000	T1 - 11	62		C6 - 42	16	SA3294001	H - 14	38	SA4545001	J - 41	40
S35079000	D2 - 35	26		C6 - 51	16	SA3295001	H - 16	38	SA4588001	J - 49	40
S35183000	C6 - 3	16		C7 - 31	18	SA3296001	H - 20	38	SA4594001	A - 1	2
	C7 - 3	18		C7 - 36	18	SA3297001	H - 21	38	SA4596001	A - 3	2
S37037001	Z - 34	68		C7 - 45	18	SA3298001	H - 25	38	SA4600102	A - 19	2
S37059001	M1 - 6	50		C8 - 30	20	SA3299001	H - 26	38	SA4601001	A - 20	2
	Wa	71		C8 - 35	20	SA3306001	A - 11	2	SA4603102	A - 22	2
S37060001	A - 43	2		C8 - 43	20		G - 4	36	SA4604101	A - 10	2
	M1 - 5	50		C8 - 45	20		J - 14	40	SA4605001	A - 17	2
	Wa	71		G - 7	36	SA3307001	J - 8	40	SA4606201	B - 1	4
S38265000	F - 52	32		K - 27	44	SA3309201	J - 15	40	SA4608101	B - 12	4
S38266000	F - 43	32		T3 - 47	66	SA3310001	J - 16	40	SA4609101	B - 16	4
S38713100	B - 32	4	S55487001	C2 - 39	8	SA3311001	J - 17	40	SA4622001	B - 28	4
S39116100	N - 3	54	S59221301	Sp	73	SA3312201	J - 28	40	SA4647001	C1 - 15	6
	T1 - 4	62	S59222301	Sp	73	SA3313101	J - 30	40		C1 - 23	6
	T1 - 8	62	S59886001	E - 24	30	SA3321001	J - 45	40		C2 - 15	8
S40214001	Ga	75		F - 54	32	SA3336101	Sp	73		C2 - 23	8
S40574409	Z - 15	68	S59894001	T3 - 7	66		Ga	75		D2 - 27	26
S41205001	K - 4	44	SA1174002	D1 - 48	24	SA3384101	Z - 47	68		D3 - 9	28
S41206001	K - 3	44	SA1175002	D1 - 49	24	SA3385001	Z - 49	68	SA4666001	B - 30	4
S42446001	A - 18	2	SA1394101	F - 41	32	SA3392101	Z - 46	68	SA4676201	C3 - 5	10
	C1 - 31	6	SA1984001	H - 12	38	SA3395001	Z - 45	68		C4 - 5	12
	C3 - 12	10	SA1988001	H - 23	38	SA3416101	T1 - 29	62	SA4677101	C3 - 2	10
	C4 - 13	12	SA2161001	D1 - 28	24		Sp	74		C4 - 2	12
	C5 - 19	14	SA2173301	Sp	73	SA3441101	D2 - 43	26	SA4687101	C6 - 4	16
	Z - 60	68	SA2195001	D1 - 53	24		D2 - 48	26	SA4688001	C6 - 6	16
S42843001	Sp	74	SA2287001	K - 16	44		D3 - 21	28	SA4689001	C6 - 7	16
	Ga	75	SA2864001	F - 22	32	SA3499001	B - 2	4	SA4692001	C6 - 11	16
S42844001	Sp	74	SA2929001	F - 44	32	SA3503201	F - 9	32		C6 - 27	16
	Ga	75	SA2958001	B - 20	4	SA3504201	F - 10	32		C7 - 17	18
S42845001	Ga	75	SA2972001	C1 - 20	6	SA3520501	G - 40	36		C8 - 15	20
S42846001	Ga	75		C2 - 20	8	SA3528001	B - 26	4	SA4693001	C6 - 18	16
S42847001	Ga	75	SA3206001	B - 5	4	SA3538001	C1 - 37	6	SA4706101	C6 - 40	16
S42848001	Ga	75		B - 9	4		C1 - 52	6		C7 - 29	18
S42849101	Ga	75	SA3224001	B - 31	4		C2 - 43	8		C8 - 26	20
S44010001	A - 40	2	SA3226001	E - 1	30		C2 - 58	8		C8 - 28	20
S44633001	Sp	73	SA3227001	D1 - 42	24		C2 - 60	8	SA4709001	C6 - 45	16
S46903001	J - 18	40		E - 2	30		C3 - 14	10		C7 - 34	18
S47307001	E - 34	30	SA3228101	E - 3	30		J - 69	42		C7 - 39	18
S48140002	T1 - 30	62	SA3231001	C6 - 15	16	SA3707101	C5 - 12	14		C8 - 33	20
S48189000	F - 26	32		C6 - 31	16	SA4025001	F - 21	32		C8 - 38	20

索引 / Index

CODE	REF.NO	Page	CODE	REF.NO	Page	CODE	REF.NO	Page	CODE	REF.NO	Page
SA4712001	C7 - 27	18	SA4796001	H - 19	38	SA6448301	Sp	73	SA9565001	M1 - 16	50
	C8 - 25	20	SA4797101	B - 38	4	SA6450101	C5 - 14	14	SA9602101	M1 - 12	50
SA4714001	C7 - 28	18	SA4798001	J - 3	40		C5 - 26	14	SA9616001	M2 - 1+	52
	C8 - 27	20	SA4799001	J - 13	40	SA6451101	C5 - 15	14	SA9725001	M1 - 11	50
SA4717001	C7 - 4	18	SA4806101	K - 7	44		C5 - 28	14		Wa	71
	C8 - 2	20	SA4811001	Ga	75	SA6560101	P - 25	56	SA9793001	E - 26	30
SA4719001	C7 - 6	18	SA4815201	Sp	74	SA6572001	J - 29	40		F - 55	32
	C8 - 4	20	SA4846002	Z - 54	68	SA6576001	F - 17	32	SA9826001	A - 42	2
SA4720001	C7 - 8	18	SA4852201	C5 - 2	14		F - 60	32		Wa	71
	C8 - 6	20	SA4853001	D1 - 39	24	SA6580001	F - 15	32	SA9831001	M2 - 1+	52
SA4721001	C7 - 9	18	SA4863001	C7 - 23	18	SA6593001	F - 14	32	SA9853101	K - 2	44
	C8 - 7	20		C8 - 21	20	SA6594001	C3 - 13	10	SA9893001	M1 - 7	50
SA4736001	D2 - 7	26	SA4864001	C6 - 37	16	SA6595001	C9 - 7	22	SA9914001	M2 - 7	52
SA4737001	D2 - 10	26		C7 - 25	18	SA6596001	J - 59	40		Wa	71
SA4738001	D2 - 16	26		C8 - 23	20	SA6599001	C9 - 8	22	SA9957001	A - 44	2
SA4739001	D2 - 18	26	SA4870201	C8 - 42	20	SA6600001	C9 - 9	22		C1 - 55	6
SA4741301	D2 - 19	26	SA4871201	C8 - 44	20	SA6603001	C9 - 4	22		Wa	71
	D3 - 1	28	SA5191001	N - 13	54	SA6604001	C9 - 2	22	SA9957002	A - 45	2
SA4743001	D2 - 24	26	SA5210001	P - 13	56	SA6607001	Z - 24	68		Wa	71
	D3 - 6	28	SA5213001	K - 26	44		Z - 25	68	SB0445001	N - 8	54
SA4744001	D2 - 26	26	SA5219001	K - 18	44	SA6609001	Z - 28	68	SB0468001	Z - 53	68
	D3 - 8	28	SA5221001	Sp	73	SA6615001	Z - 29	68	SB0556001	Z - 41	68
SA4745001	D2 - 31	26		Ga	75	SA6616001	T3 - 44	66	SB0557301	Z - 36	68
	D3 - 13	28	SA5222101	Sp	73	SA6617001	T3 - 43	66	SB0559101	Z - 40	68
SA4746001	D2 - 34	26		Ga	75	SA6640101	C9 - 12	22	SB0623001	Sp	73
SA4747001	D2 - 38	26	SA5251001	Z - 55	68	SA7141001	C9 - 1	22	SB0705101	D2 - 17	26
	D3 - 16	28	SA5281201	N - 1	54	SA7155001	T1 - 25	62	SB0713001	J - 72	42
SA4748101	D2 - 40	26	SA5282001	N - 5	54		T2 - 6	64	SB0752101	Q - 1	58
	D3 - 18	28	SA5283001	N - 4	54	SA7166101	T1 - 6	62	SB0787101	L1 - 14	46
SA4750001	D2 - 47	26	SA5286101	N - 10	54	SA7167101	T1 - 9	62		L2 - 16	48
SA4752001	D2 - 53	26	SA5289001	N - 2	54	SA7171001	T1 - 7	62	SB0794101	L1 - 10	46
SA4753001	D2 - 55	26	SA5290001	T1 - 3	62	SA7189101	T3 - 1	66		L2 - 10	48
	D3 - 25	28	SA5294001	F - 7	32	SA7191001	Ga	75	SB0910201	B - 47	4
SA4757101	D3 - 31	28	SA5300001	D1 - 50	24	SA7193001	T3 - 22	66	SB1038001	B - 42	4
SA4759001	D1 - 1	24	SA5301001	D1 - 52	24	SA7197101	T1 - 10	62	SB1040001	B - 48	4
SA4760001	D1 - 2	24	SA5339101	F - 56	32	SA7199001	T1 - 22	62	SB1041001	B - 46	4
SA4761001	D1 - 7	24	SA5415001	C9 - 11	22	SA7385001	C9 - 10	22	SB1086001	G - 12	36
SA4762001	D1 - 8	24	SA5559101	T2 - 1	64	SA7460001	T3 - 36	66	SB1088101	G - 27	36
SA4763001	D1 - 3	24	SA5593001	C1 - 7	6	SA7500001	T1 - 1	62	SB1179001	L1 - 8	46
SA4764001	D1 - 11	24		C1 - 28	6	SA7501001	T1 - 2	62		L2 - 8	48
SA4765001	D1 - 13	24		C2 - 28	8	SA7588001	N - 7	54	SB1180201	G - 28	36
SA4766001	D1 - 16	24		D2 - 1	26	SA7704001	D1 - 4	24	SB1181001	G - 29	36
SA4767001	D1 - 17	24	SA6038101	R - 2	60	SA7944101	Sp	73	SB1182101	G - 35	36
SA4768001	D1 - 18	24	SA6087001	F - 18	32	SA8057001	K - 12	44	SB1192001	L1 - 13	46
SA4769101	D1 - 19	24	SA6182001	B - 19	4	SA8197101	Sp	73		L2 - 14	48
SA4770001	D1 - 21	24	SA6190001	G - 30	36	SA8239202	Z - 12	68	SB1200101	P - 11	56
SA4771001	D1 - 27	24	SA6193001	Sp	74	SA8560001	C3 - 3	10	SB1229001	M2 - 5+	52
SA4772001	D1 - 22	24	SA6207001	A - 26	2		C4 - 3	12	SB1253001	H - 28	38
SA4773001	D1 - 23	24	SA6210001	D2 - 42	26	SA8672001	C4 - 9	12	SB1267001	G - 31	36
SA4775101	D1 - 38	24		D3 - 20	28	SA8679001	A - 15	2	SB1270001	Z - 13	68
SA4777001	D1 - 26	24	SA6261002	Z - 72	70	SA8684001	D1 - 40	24		Wa	72
SA4778001	D1 - 46	24	SA6272001	A - 23	2	SA8689001	D1 - 43	24	SB1271001	Z - 14	68
SA4779101	D1 - 32	24	SA6273101	J - 70	42	SA8691001	G - 16	36		Wa	72
SA4780001	D1 - 35	24	SA6308001	C1 - 54	6	SA8707001	E - 48	30	SB1277001	A - 8	2
SA4781001	D1 - 33	24	SA6362001	T3 - 20	66	SA9191001	C2 - 59	8	SB1281001	G - 33	36
SA4782001	E - 4	30	SA6366001	P - 23	56		E - 32	30	SB1565001	R - 1	60
SA4783101	E - 10	30	SA6373001	T3 - 8	66	SA9207001	G - 18	36	SB2097001	B - 44	4
SA4785101	F - 2	32	SA6391001	G - 10	36	SA9396001	E - 23	30	SB2131001	C6 - 39	16
SA4786101	F - 8	32	SA6405001	N - 14	54	SA9397001	E - 25	30	SB2356001	Z - 63	70
SA4787001	F - 5	32	SA6405002	N - 16	54	SA9500201	M1 - 4	50		Z - 65	70
SA4788001	F - 12	32	SA6406001	N - 15	54	SA9535001	M2 - 2+	52	SB2456001	A - 16	2
SA4789101	F - 29	32	SA6406002	N - 17	54	SA9559001	M1 - 14	50		T3 - 33	66
SA4791101	F - 35	32	SA6407001	N - 18	54	SA9564001	M1 - 15	50	SB2636001	G - 2	36

CODE	REF.NO	Page	CODE	REF.NO	Page	CODE	REF.NO	Page	CODE	REF.NO	Page
SB3511001	E - 28	30	SB4343001	C5 - 4	14	SB4406001	C2 - 14	8	SB5937001	C2 - 53	8
SB3847001	C2 - 7	8	SB4344101	C1 - 1	6		C2 - 25	8	SB5938001	C8 - 1	20
	C2 - 33	8	SB4346001	C5 - 1	14	SB4407101	C3 - 6	10	SB5966001	C2 - 11	8
	C2 - 35	8	SB4351001	C1 - 8	6		C4 - 6	12	SB5967001	C2 - 5	8
	C2 - 38	8	SB4352001	F - 63	34	SB4408101	C3 - 7	10	SB5968001	C2 - 1	8
	J - 65	42	SB4356001	C1 - 36	6		C4 - 7	12	SB5969001	C2 - 30	8
SB3848001	C1 - 38	6	SB4357001	C1 - 35	6	SB4409001	C3 - 8	10	SB5974001	C2 - 48	8
	C1 - 51	6	SB4360001	C1 - 41	6	SB4412001	Z - 1	68	SB5975001	C2 - 49	8
	C2 - 44	8	SB4361001	C1 - 48	6	SB4413001	A - 29	2	SB5978001	A - 14	2
	C2 - 57	8		C2 - 54	8	SB4414001	C6 - 17	16	SB6019001	Q - 2	58
	D2 - 30	26	SB4362001	C1 - 45	6	SB4415001	J - 36	40	SB6261001	L1 - 12	46
	D3 - 12	28		C2 - 50	8	SB4416001	J - 20	40		L2 - 13	48
	J - 7	40		C2 - 51	8	SB4420001	C6 - 33	16	SB6264001	G - 39	36
	K - 11	44	SB4363001	C1 - 46	6	SB4421001	C6 - 23	16	SB6313001	Q - 3	58
	L1 - 4	46	SB4364101	C5 - 27	14	SB4422001	C6 - 24	16	SB6414001	M1 - 1	50
	L2 - 4	48	SB4365101	C1 - 47	6	SB4423001	D2 - 5	26	SB6433001	G - 26	36
	T3 - 40	66	SB4366001	C1 - 34	6	SB4424001	D2 - 4	26	SB6467001	L1 - 1	46
SB3849001	C6 - 35	16	SB4367001	C6 - 10	16	SB4432001	C1 - 11	6	SB6468002	G - 25	36
	C6 - 49	16	SB4368001	C6 - 9	16	SB4433001	C6 - 1	16	SB6472001	Q - 4	58
	C7 - 41	18	SB4369001	C7 - 13	18	SB4453001	C6 - 41	16	SB6488001	C1 - 5	6
	C8 - 40	20		C8 - 11	20	SB4454001	C7 - 1	18	SB6525001	Q - 5	58
SB4037001	F - 58	32	SB4370001	C7 - 12	18	SB4455001	C7 - 30	18	SB6532001	Q - 25+	58
SB4096001	P - 17	56	SB4370101	C8 - 10	20		C8 - 29	20	SB6532002	Q - 25+	58
SB4155001	F - 3	32	SB4371001	C7 - 11	18	SB4456001	C7 - 35	18	SB6538001	Q - 6	58
	L2 - 12	48	SB4371101	C8 - 9	20		C8 - 34	20	SB6539001	Q - 7	58
	P - 22	56	SB4373001	C6 - 47	16	SB4457001	C6 - 46	16	SB6540001	Q - 8	58
	P - 24	56	SB4374001	C6 - 20	16	SB4458001	C5 - 8	14	SB6541001	Q - 9	58
	P - 26	56	SB4375001	C6 - 19	16	SB4459201	C5 - 20	14	SB6542001	Q - 10	58
SB4168001	Z - 7	68	SB4376001	C6 - 22	16	SB4460001	C7 - 43	18	SB6545001	Q - 11	58
SB4169001	Z - 37	68	SB4377001	C6 - 26	16	SB4461001	C7 - 44	18	SB6546001	Q - 12	58
SB4181001	C5 - 32	14	SB4378001	K - 9	44	SB4464101	E - 30	30	SB6547001	Q - 13	58
SB4183101	C3 - 1	10	SB4379001	K - 6	44	SB4467101	L2 - 1	48	SB6551001	Q - 14	58
SB4184001	C1 - 9	6	SB4380001	L1 - 9	46	SB4468001	F - 42	32	SB6552001	Q - 15	58
SB4185501	C1 - 6	6		L2 - 9	48	SB4469001	C1 - 24	6	SB6554001	Q - 19	58
SB4186201	C1 - 2	6	SB4381001	D2 - 2	26		C2 - 24	8	SB6555001	Q - 20	58
SB4187101	E - 11	30	SB4382001	D2 - 20	26	SB4486001	L2 - 15	48	SB6556001	Q - 21	58
SB4188001	C5 - 22	14		D3 - 2	28	SB4500001	B - 49	4	SB6557001	Q - 18	58
SB4189001	F - 65	34	SB4383001	Z - 6	68	SB4508101	E - 15	30	SB6577001	J - 4	40
SB4259001	P - 14	56	SB4384001	A - 32	2	SB4509001	E - 16	30	SB6581001	Q - 26+	58
SB4260001	P - 7	56	SB4385101	A - 31	2	SB4515001	Z - 5	68	SB6581002	Q - 26+	58
SB4261001	P - 15	56	SB4387001	F - 48	32	SB4516001	Z - 59	68	SB6587001	G - 1	36
SB4270001	B - 41	4	SB4388001	F - 49	32	SB4517001	Z - 58	68	SB6613001	F - 36	32
SB4275001	C5 - 9	14	SB4389001	H - 1	38	SB4524001	F - 23	32			
SB4276001	C5 - 21	14	SB4391001	J - 37	40	SB4525001	C6 - 52	16			
SB4277001	D3 - 4	28	SB4392001	E - 29	30		C7 - 46	18			
SB4277201	D2 - 22	26	SB4393001	J - 21	40		C8 - 46	20			
SB4281101	C1 - 29	6	SB4394001	J - 56	40	SB4541101	M1 - 2	50			
SB4282001	C1 - 21	6	SB4395001	J - 48	40	SB4570001	F - 57	32			
	C2 - 21	8	SB4396001	J - 54	40	SB4595001	J - 58	40			
SB4296101	P - 9	56	SB4397001	J - 35	40	SB4689201	C1 - 53	6			
SB4297101	K - 1	44	SB4398001	J - 44	40	SB4736001	F - 61	32			
SB4334001	C5 - 10	14	SB4399001	J - 40	40	SB4810001	C8 - 39	20			
SB4335001	C1 - 32	6	SB4400001	J - 55	40	SB5071001	C5 - 31	14			
SB4337001	C1 - 30	6	SB4401001	J - 24	40	SB5072001	C1 - 43	6			
SB4338001	C1 - 27	6		J - 25	40	SB5073001	C1 - 44	6			
	C2 - 27	8		J - 46	40	SB5077001	C2 - 52	8			
SB4339001	C1 - 16	6		J - 51	40	SB5848001	C2 - 29	8			
	C2 - 16	8	SB4402001	C1 - 10	6	SB5925001	C4 - 1	12			
SB4340001	C1 - 17	6	SB4403001	Z - 2	68	SB5926001	C4 - 8	12			
	C2 - 17	8	SB4404001	C6 - 2	16	SB5931001	C2 - 40	8			
SB4341001	C1 - 12	6		C7 - 2	18	SB5932101	C2 - 41	8			
	C2 - 12	8	SB4406001	C1 - 14	6	SB5933101	C2 - 42	8			
SB4342001	C5 - 6	14		C1 - 25	6	SB5934101	C2 - 47	8			

brother

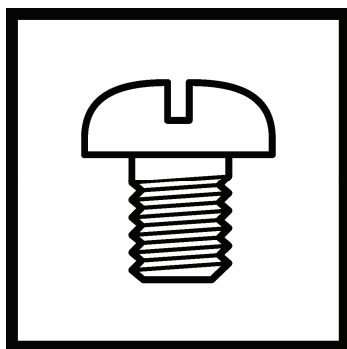

パーツブック
PARTS BOOK

ブラザー工業株式会社 <http://www.brother.co.jp/>

〒448-0803 刈谷市野田町北地蔵山1番地5 TEL:0566-95-0085

BROTHER INDUSTRIES, LTD. <http://www.brother.com/>

1-5, Kitajizoyama, Noda-cho, Kariya 448-0803, Japan. Phone : 81-566-95-0088